

Lawrence Berkeley National Laboratory

Lawrence Berkeley National Laboratory

Title

NUCLEAR DEFORMATION ENERGIES

Permalink

<https://escholarship.org/uc/item/0bs463jk>

Author

Blocki, J.

Publication Date

2009-07-20



Lawrence Berkeley Laboratory

UNIVERSITY OF CALIFORNIA

NUCLEAR DEFORMATION ENERGIES

J. Błocki and W.J. Świątecki

May 1982

TWO-WEEK LOAN COPY

*This is a Library Circulating Copy
which may be borrowed for two weeks.
For a personal retention copy, call
Tech. Info. Division, Ext. 6782.*

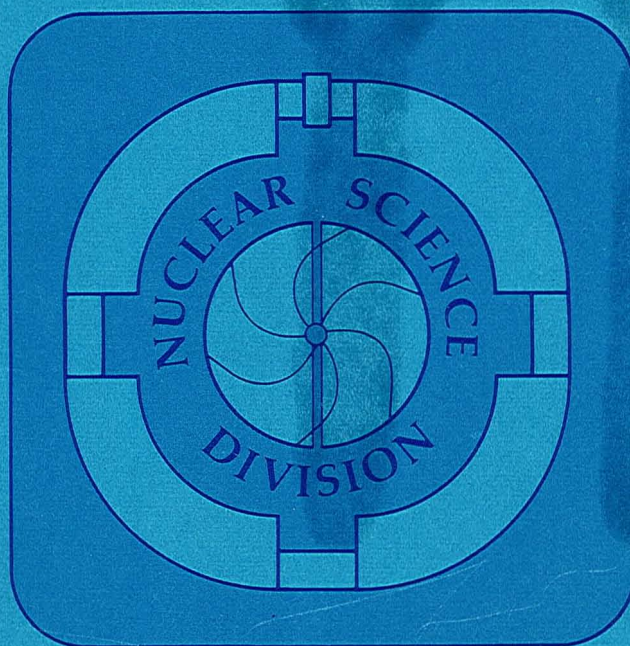

RECEIVED
LAWRENCE
BERKELEY LABORATORY
JAN 11 1983
LIBRARY AND
DOCUMENTS SECTION

*LBL-12811
e-2*

LEGAL NOTICE

This book was prepared as an account of work sponsored by an agency of the United States Government. Neither the United States Government nor any agency thereof, nor any of their employees, makes any warranty, express or implied, or assumes

LBL-12811

C.2

Lawrence Berkeley Laboratory Library
University of California, Berkeley

LBL-12811

Nuclear Deformation Energies
According to a Liquid Drop Model
with a Sharp Surface

J. Błocki
Institute for Nuclear Research
05-400 Świerk, Poland

and

W.J. Świątecki
Nuclear Science Division
Lawrence Berkeley Laboratory
University of California
Berkeley, CA 94720

May 1982

This work was supported by the Director, Office of Energy Research, Division of Nuclear Physics of the Office of High Energy and Nuclear Physics of the U.S. Department of Energy under Contract DE-AC03-76SF00098.



Nuclear Deformation Energies

(Sharp Liquid Drop)

An atlas of deformation-energy maps relevant for
nuclear fission and nucleus-nucleus collisions

J. Błocki
Institute for Nuclear Research
05-400 Świerk, Poland

and

W.J. Świątecki
Nuclear Science Division
Lawrence Berkeley Laboratory
University of California
Berkeley, CA 94720

May 1982

ABSTRACT

We present an atlas of 665 deformation-energy maps and 150 maps of other properties of interest, relevant for nuclear systems idealized as uniformly charged drops endowed with a surface tension. The nuclear shapes are parametrized in terms of two spheres modified by a smoothly fitted quadratic surface of revolution and are specified by three variables: asymmetry, sphere separation, and a neck variable (that goes over into a fragment-deformation variable after scission). The maps and related tables should be useful for the study of macroscopic aspects of nuclear fission and of collisions between any two nuclei in the periodic table.

1. Introduction

The binding energy (or mass) of an atomic nucleus may be considered as made up of a "local" part, akin to the energy of a (liquid) drop endowed with a surface tension, and of a "nonlocal" part (Coulomb energy, Proximity energy, and Shell Effects--see Refs. 1,2,3). The two leading terms in the local

(liquid drop) part are a shape-independent volume energy and a surface energy proportional to the surface area of the shape in question. Together with the electrostatic energy of a uniform distribution of electric charge inside the given shape, these contributions represent the major part of the potential energy of a nuclear system.

Expressions for the surface and electrostatic energies are easy to write down but often cumbersome to evaluate for nuclear shapes of actual interest. As a result, even though some of the most important features of the deformation energy of a uniformly charged drop have been adequately studied and tabulated (Refs. 4,5,6,7,11), there are others that are still not well understood--more than forty years since the introduction of the deformable charged liquid-drop model in connection with nuclear fission. The need for a better understanding of nuclear deformation energies is becoming more acute with the increasing interest in the physics of nucleus-nucleus collisions, in which a variety of configurations, not encountered in fission, make their appearance. It is this great variety of potentially interesting nuclear shapes that makes a survey of nuclear deformation energies (even within the simplest liquid-drop model) not a trivial undertaking. Thus, formally, the specification of a shape requires an infinite number of degrees of freedom, calling for tabulations in an infinitely dimensional space. However, in the context of nuclear fission and nucleus-nucleus collisions, a number of interesting phenomena may be encompassed in a description that uses three well-chosen shape degrees of freedom (corresponding, roughly, to an asymmetry variable, an elongation or separation variable, and a neck or fragment-deformation variable--see Refs. 8,9). The present work is concerned with the display of sums of the local (liquid-drop) nuclear energy and the Coulomb energy, for systems accessible through the collision of any two nuclei

in the Periodic Table of elements. The display is in the form of maps, in which the energy is plotted as a function of the separation and neck variables at a series of fixed asymmetries. (Previous, less extensive maps may be found in Ref. 6).

2. Parametrization of Nuclear Shapes

The shapes we consider are all restricted to axial symmetry and correspond to two (generally unequal) spheres, modified by a smoothly fitted portion of a third quadratic surface of revolution. For pre-scission (undivided) shapes, shown in Fig. 2, the parametrization is a special three-parameter sub-family of the five-parameter family introduced in the context of nuclear fission in Refs. 10,11 and used extensively, for example, in Refs. 12,13,14. For post-scission (separated) shapes, shown in Fig. 3b, one fragment is a sphere modified by a portion of a smoothly fitted hyperboloid of two sheets. The other fragment is obtained by a scaling down of the first, with a simultaneous reflection through the center of the hyperboloid--see below. At scission (Fig. 3a) the hyperboloids modifying the spheres degenerate into juxtaposed cones, with tips in contact.

2a. Pre-scission Shapes

Consider a cartesian system of coordinates x, y, z , and let $y(z)$ specify the curve whose revolution around the z -axis generates a solid of revolution defining the nuclear shape. Let sphere 1, with radius R_1 , have its center at the origin and let sphere 2, with radius R_2 , have its center at a distance r along the z -axis. Let the connecting quadratic surface be tangent to the two spheres at z_1 and z_2 , respectively. The whole shape consists then of a quadratic solid of revolution in the interval between z_1 and z_2 ,

plus what remains of sphere 1 after removal of a lens of thickness $R_1 - z_1$, plus what remains of sphere 2 after removal of a lens of thickness $z_2 - (r - R_2)$ (see Fig. 2b). Denote by ℓ the total thickness of the missing lenses, i.e.

$$\ell = (R_1 - z_1) + z_2 - (r - R_2) \quad . \quad (1)$$

A convenient set of three dimensionless variables describing the shape turns out to be the following:

$$\text{Asymmetry Variable:} \quad \Delta \equiv \frac{R_1 - R_2}{R_1 + R_2} \quad , \quad (2)$$

$$\text{Distance Variable:} \quad \rho \equiv \frac{r}{R_1 + R_2} \quad , \quad (3)$$

$$\text{Fragment-Deformation or Neck Variable:} \quad \lambda \equiv \frac{\ell}{R_1 + R_2} \quad . \quad (4)$$

The choice of the asymmetry variable (the same as in Ref. 15) as proportional to a difference of lengths (rather than volumes or masses) makes it homogeneous in this respect with the other two shape variables. The Fragment Deformation or Neck variable ("Deck variable" or "Deck parameter" for short) is a measure of the deviation of the actual shape from two separated, undeformed spheres. (We suggest "parametr *szyjkomacji*" as a possible Polish equivalent of "deck parameter".) For divided shapes, λ is a measure of the bulging ("polarization" or "nose-formation") of the approaching fragments. After contact, λ goes over into a measure of the degree of opening of the neck or window through which the fragments communicate. As λ increases further the neck concavity disappears and the shapes become convex everywhere.

Let us write the equations for the two spheres and for the connecting quadratic surface as follows:

$$\text{Sphere 1: } y^2 = R_1^2 - z^2, \quad (5)$$

$$\text{Sphere 2: } y^2 = R_2^2 - (z - r)^2, \quad (6)$$

$$\text{Quadratic: } y^2 = a + \beta(z - c)^2. \quad (7)$$

Using $R_1 + R_2$ as a unit of length, we may rewrite these equations in dimensionless form as

$$\eta^2(\zeta) = \begin{cases} \rho_1^2 - \zeta^2 \\ \rho_2^2 - (\zeta - \rho)^2 \\ \phi + \beta(\zeta - \zeta_c)^2 \end{cases}, \quad (8)$$

where η , ζ , ϕ , ζ_c stand for $y/(R_1+R_2)$, $z/(R_1+R_2)$, $a/(R_1+R_2)^2$ and $c/(R_1+R_2)$, respectively.

Equations for the parameters a , β , c , specifying the quadratic surface, follow elementarily from the conditions of tangency at the junction points z_1 and z_2 :

$$\frac{a}{(R_1+R_2)^2} = \frac{1}{4} \left[1 - (1 - \lambda)\rho \right] \left[1 - \frac{\Delta^2}{\rho(1-\lambda)} \right] \quad (9)$$

$$\beta = \frac{1-\lambda}{\rho-1+\lambda}, \quad (10)$$

$$\frac{c}{R_1+R_2} = \frac{1}{2} \left[\frac{\Delta}{1-\lambda} + \rho \right]. \quad (11)$$

The junction points themselves are found to be given by

$$\frac{z_1}{R_1+R_2} = \frac{\Delta}{2\rho} + \frac{1}{2} (1 - \lambda), \quad (12)$$

$$\frac{z_2}{R_1+R_2} = \frac{\Delta}{2\rho} + \rho - \frac{1}{2} (1 - \lambda). \quad (13)$$

The radii R_1, R_2 are, of course, related to Δ by the equations

$$\frac{R_1}{R_1+R_2} = \frac{1}{2} (1 + \Delta) = \rho_1, \text{ say,} \quad (14)$$

$$\frac{R_2}{R_1+R_2} = \frac{1}{2} (1 - \Delta) = \rho_2, \text{ say.} \quad (15)$$

Equations (9-15) enable one to reconstruct readily a given shape from the three shape variables Δ , ρ , λ .

2b. Post-scission Shapes

Let the equations specifying fragment 1 be as follows (see Fig. 3b):

$$\text{Sphere 1: } y^2 = R_1^2 - z^2, \quad (16)$$

$$\text{Quadratic 1: } y^2 = a_1 + \beta_1 (z - c_1)^2. \quad (17)$$

Let fragment 2 be specified by

$$\text{Sphere 2: } y^2 = R_2^2 - (z - r)^2, \quad (18)$$

$$\text{Quadratic 2: } y^2 = a_2 + \beta_2 (z - r + c_2)^2. \quad (19)$$

These equations, when divided by $(R_1+R_2)^2$, specify the post-scission function $\eta(\zeta)$.

The conditions of tangency at z_1, z_2 and the condition that fragment 2 be a scaled-down version of fragment 1, with simultaneous reflection through the center at $z = c_1$, may be shown to lead to the following equations for the parameters $a_1, \beta_1, c_1, a_2, \beta_2, c_2$:

$$\frac{a_1}{(R_1+R_2)^2} = \frac{1}{4} [1 - (1 - \lambda)\rho](1 + \Delta)^2, \quad (20)$$

$$\frac{a_2}{(R_1+R_2)^2} = \frac{1}{4} [1 - (1 - \lambda)\rho](1 - \Delta)^2, \quad (21)$$

$$\beta_1 = \beta_2 = \frac{1-\lambda}{\rho-1+\lambda} (= \beta), \quad (22)$$

$$\frac{c_1}{R_1+R_2} = \frac{1}{2} (1 + \Delta)\rho, \quad (23)$$

$$\frac{c_2}{R_1+R_2} = \frac{1}{2} (1 - \Delta)\rho. \quad (24)$$

The junction points are now given by

$$\frac{z_1}{R_1+R_2} = \frac{1}{2} (1 + \Delta)(1 - \lambda), \quad (25)$$

$$\frac{z_2}{R_1+R_2} = -\frac{1}{2} (1 - \Delta)(1 - \lambda) + \rho. \quad (26)$$

At scission the hyperbolas given by eqs. 17,19 degenerate into cones (i.e. $a_1 = a_2 = 0$), which implies, according to eqs. 20,21, that

$$\lambda_{\text{scission}} = 1 - \frac{1}{\rho}. \quad (27)$$

3. The Configuration Space

In the configuration space where Δ , ρ , λ are considered as cartesian coordinates (Fig. 4) the extreme values of Δ , equal to ± 1 , define two vertical plane boundaries. The least value of λ , equal to zero, defines a horizontal plane boundary (passing through the origin). The value of ρ may range from zero to ∞ (or even $-\infty$ to $+\infty$), but in the interval $0 < \rho < 1$ (the value $\rho = 1$ corresponds to tangent spheres) the range in λ is limited from below by the value corresponding to intersecting spheres (without any additional neck rounding off the intersection crevice). This least value of λ is defined by

the condition of coalescence of the junction points (i.e., $z_1 = z_2$) which, in virtue of eqs. 12,13, gives

$$\lambda = 1 - \rho \quad (34)$$

In configuration space this equation defines a plane inclined at -45° (see Fig. 4).

The range of λ is also limited from above. Thus, as a larger and larger fraction of the original spheres is taken over by the middle quadratic surface, there comes a point where the smaller one of the two spheres gets swallowed up entirely by the middle quadratic. When $\Delta > 0$ and sphere 2 is the smaller one, this occurs when the junction point z_2 reaches the tip of sphere 2 at $z = r + R_2$. According to eq. 13 this defines the surface

$$\lambda = 2 - \Delta - \frac{\Delta}{\rho}. \quad (35)$$

On this surface the shapes belong to a two-parameter family of egg-like "ovoids". They consist of a portion of a sphere joined to a bulge in the form of a piece of a spheroid (if $\lambda > 1$), a piece of a paraboloid (if $\lambda = 1$), or a piece of a hyperboloid of two sheets (if $\lambda < 1$).

As λ is increased still further the larger of the two spheres gets swallowed up in its turn. This occurs when $z_1 = -R_1$, which, according to eq. 12, leads to

$$\lambda = 2 + \Delta + \frac{\Delta}{\rho}. \quad (36)$$

(On this surface the shapes are a one-parameter family of spheroids with varying eccentricity.) As is readily verified, no intrinsically new shapes are generated by exceeding the limit set by eq. 35, which may then be taken as the upper boundary surface in configuration space when $\Delta > 0$. On the other hand, when $\Delta < 0$, eq. 36 is the effective upper boundary.

In summary then, the configuration space may be considered as confined to the inside of a semi-infinite "box", whose boundaries are given by the planes $\Delta = \pm 1$, $\lambda = 0$, $\lambda = 1 - \rho$, and by the surface $\lambda = 2 - |\Delta| - |\Delta|/\rho$. Because of the symmetry of the problem, only positive values of Δ need be considered.

Inside the configuration box, the scission surface given by $\lambda = 1 - \rho^{-1}$ (eq. 27), divides the space into pre-scission and post-scission regions. In the pre-scission region an important characteristic of necked-in shapes is the degree of communication between the two pieces, related to the cross-sectional area of the neck or window joining the fusing or separating fragments. In analogy with Ref. 15, we define the degree of window opening by drawing two cones, one tangent to the spheres (with apex at $z = z_0$ to the right of sphere 2 and with semi-opening angle θ_{\max}) and another, also with apex at z_0 , but with semi-opening angle θ chosen to make the cone tangent to the (concave) neck. The degree of window opening, α , is now defined by

$$\alpha \equiv \left(\frac{\sin \theta}{\sin \theta_{\max}} \right)^2,$$

which is readily verified to lead to

$$\alpha = \frac{1 - (1 - \lambda)\rho}{1 - \Delta^2}.$$

At scission, we have $(1 - \lambda)\rho = 1$ (see eq. 27), so $\alpha = 0$. The window is fully open when the neck has lost its concavity and has become a portion of a cone tangent to the spheres. According to eq. 9 this occurs when $\Delta^2 = \rho(1 - \lambda)$, which leads to $\alpha = 1$. Curves corresponding to a degree of window opening of 0, 25%, 50%, 75%, 100% are shown in Figs. (5-8). Values of α greater than 1 indicate that the shape has become convex everywhere. At the upper boundary of the configuration space one finds $\alpha = (1 + \rho)/(1 + |\Delta|)$.

Various features of the configuration space are illustrated in Fig. 4.

4. Formulae for Six Integral Shape Characteristics

a) The Scale Function

The natural unit of length in equations 9-13 and 20-26 is the sum $R_1 + R_2$. (Note that, except for separate and undeformed spheres, $\frac{4}{3}\pi R_1^3$ and $\frac{4}{3}\pi R_2^3$ are not the volumes of the two fragments.) In order to reconstruct a shape in units of the standard length R (the radius of a single sphere with the same volume as the shape in question), one needs the Scaling Function S , defined by

$$S = \frac{R_1 + R_2}{R}. \quad (37)$$

The explicit equation for $S(\Delta, \rho, \lambda)$ follows from writing down the integral for the volume of a shape specified by Δ, ρ, λ , and equating it to $(4/3)\pi R^3$. The result is

$$S(\Delta, \rho, \lambda) = \left[\frac{\int \pi y^2(z) dz}{\frac{4}{3}\pi(R_1 + R_2)^3} \right]^{-1/3} = \left[\frac{3}{4} \int_{-\rho_1}^{\rho + \rho_2} n^2 d\zeta \right]^{-1/3}, \quad (38)$$

where $n^2(\zeta)$ is given by eqs. 8 for pre-scission shapes and follows from eqs. 16-19 for post-scission shapes. The integral over the square of n (a set of second-order polynomials) is elementary.

b) Moments of Inertia and Quadrupole Moment

Important characteristics of the shapes are the two principal moments of inertia \mathcal{J}_{\parallel} and \mathcal{J}_{\perp} and the (mass) quadrupole moment. Here \mathcal{J}_{\parallel} is the moment of inertia about the symmetry axis and \mathcal{J}_{\perp} is the moment of inertia about an orthogonal axis passing through the center of mass. Denoting by \mathcal{J}_0 the moment of inertia of the standard sphere R , and using $d\tau$ to denote a volume element, we may write

$$\frac{J_{\parallel}}{J_0} = \frac{\iiint (x^2+y^2) d\tau}{\frac{2}{5} \left(\frac{4}{3} \pi R^3\right) R^2} = \frac{\frac{1}{2} \int \pi y^4(z) dz}{\frac{8}{15} \pi R^5} = \frac{15}{16} S^5 \int_{-\rho_1}^{\rho_2} n^4 d\zeta, \quad (39)$$

where $y(z)$ is the function defined by eqs. 5-7 or 16-19 and n is $y(z)/(R_1+R_2)$.

The formula for J_{\perp}/J_0 is derived as follows:

$$\begin{aligned} \frac{J_{\perp}}{J_0} &= \frac{\iiint [(z-z_{CM})^2+y^2] d\tau}{\frac{2}{5} \left(\frac{4}{3} \pi R^3\right) R^2} = \frac{\iiint (z^2+y^2) d\tau}{\frac{8}{15} \pi R^5} - \frac{5}{2} \frac{z_{CM}^2}{R^2} \\ &= \frac{\iiint z^2 d\tau}{\frac{8}{15} \pi R^5} + \frac{1}{2} \frac{J_{\parallel}}{J_0} - \frac{5}{2} \frac{z_{CM}^2}{R^2} \\ &= \frac{15}{8} S^5 \int_{-\rho_1}^{\rho_2} n^2 \zeta^2 d\zeta + \frac{1}{2} \frac{J_{\parallel}}{J_0} - \frac{5}{2} S^2 \zeta_{CM}^2. \end{aligned} \quad (40)$$

In the above, z_{CM} locates the center of mass and ζ_{CM} , defined as $z_{CM}/(R_1+R_2)$, is given by

$$\zeta_{CM} = \frac{1}{R_1+R_2} \frac{\int \pi y^2(z) z dz}{\int \pi y^2(z) dz} = \frac{\int n^2 \zeta d\zeta}{\int n^2 d\zeta} = \frac{3}{4} S^3 \int_{-\rho_1}^{\rho_2} n^2 \zeta d\zeta. \quad (41)$$

Defining the dimensionless quantity Q as the mass quadrupole moment divided by the mass of the standard sphere times R^2 , we have

$$\begin{aligned} Q &= \frac{\iiint [2(z-z_{CM})^2-x^2-y^2] d\tau}{\left(\frac{4}{3} \pi R^3\right) R^2} \\ &= \frac{4}{5} \left(\frac{J_{\perp}}{J_0} - \frac{J_{\parallel}}{J_0} \right). \end{aligned} \quad (42)$$

All the integrals appearing in eqs. 39-41 are again elementary.

c) Surface Energy

We denote by F the dimensionless quantity defined by

$$\begin{aligned} F &= \frac{(\text{Surface Energy})}{(\text{Surface Energy of Sphere } R)} \\ &= \frac{\int 2\pi y(z) \sqrt{dy^2+dz^2}}{4\pi R^2} \\ &= \frac{1}{2} S^2 \int_{-\rho_1}^{\rho_2} n \sqrt{1 + \left(\frac{dn}{d\zeta}\right)^2} d\zeta. \end{aligned} \quad (43)$$

The integral is again elementary and expressible in terms of inverse trigonometric or logarithmic functions.

d) Coulomb Energy

We denote by G the dimensionless quantity

$$\begin{aligned} G &\equiv \frac{(\text{Coulomb Energy})}{(\text{Coulomb Energy of Sphere } R)} \\ &= \frac{\langle r_{12}^{-1} \rangle}{\langle r_{12}^{-1} \rangle_{\text{sphere}}}, \end{aligned} \quad (44)$$

where $\langle r_{12}^{-1} \rangle$ is the average value of the inverse distance between pairs of points inside the shape in question and $\langle r_{12}^{-1} \rangle_{\text{sphere}}$ [equal to $(6/5)R^{-1}$] is this quantity evaluated for a sphere.

The Coulomb energy integral in eq. 44 was evaluated numerically using the method described in Ref. 11. In the numerical integrations over z the range of integration was divided into four regions as follows (see Figs. 2,3b): from the tip $z = -R_1$ to the junction point z_1 , from the junction point to the tip z_3 (for post-scission shapes) or to the "symmetry point" z_{CUT} (for pre-scission shapes), plus two more regions, defined analogously for the

remainder of the figure. In each region a Gaussian N-point quadrature formula was used. After studies of accuracy using N up to 16, a compromise value of N = 8 was adopted. For typical shapes this gives 32 points in the full interval of z. The greatest inaccuracies occur when the shape degenerates into a single spheroid and there are, in effect, only 16 points in the full range, or, for separated spheres, when each sphere has to make do with only 8 points. In the former case the exact value of G, for a spheroid with a ratio of axes 2:1, is 0.9579759 and the numerical integration gives 0.9582123, an error of 0.0002364 or about 0.025%. In the latter case the exact value of G for equal tangent spheres is 0.8924441 and the numerical integration gives 0.8923276, implying an error of -0.0001165 or about -0.013%. In most cases, the numerically calculated values are considerably more accurate.

4. The Nuclear Deformation Energy

In the present approximation, the deformation energy of a nucleus, ΔE , taken with respect to the energy of the standard sphere R, and expressed in units of the surface energy of that sphere, may be written as follows

$$\xi \equiv \frac{\Delta E}{4\pi R^2 \gamma} = \frac{1}{4\pi R^2 \gamma} [\text{Surface Energy} - 4\pi R^2 \gamma + \text{Coulomb Energy} - \frac{3}{5} \frac{(\text{Charge})^2}{R}]$$

$$= F - 1 + 2x(G - 1) \quad , \quad (45)$$

where γ is the nuclear surface energy coefficient, "Charge" is the total electric charge on the system and x is the nuclear fissility parameter, defined by

$$x = \frac{(\text{Charge})^2}{10(\text{Volume})(\text{Surface Energy Coefficient})}$$

$$= \frac{3}{5} \frac{(\text{Charge})^2}{R} \bigg/ 8\pi R^2 \gamma$$

$$= \frac{E_C^{(0)}}{2E_S^{(0)}} \quad , \quad (46)$$

where $E_C^{(0)}$ and $E_S^{(0)}$ are the Coulomb and surface energies of the sphere.

With (F - 1) and (G - 1) tabulated once and for all using eqs. 43, 44, the deformation energies of different idealized nuclei may be deduced by mixing these two contributions in the proportion prescribed by eq. 45, using the fissility parameter x appropriate to the nucleus in question.

5. Nominal Values of Nuclear Parameters

For a nucleus with atomic number Z, neutron number N, mass number A (= N+Z) and relative neutron excess I (= (N-Z)/A), we shall adopt as nominal estimates of the Coulomb and surface energies the values given in Ref. 16:

$$E_C^{(0)} = \frac{3}{5} \frac{(\text{Charge})^2}{R} = 0.7053 \frac{Z^2}{A^{1/3}} \text{ MeV} \quad , \quad (47)$$

$$E_S^{(0)} = 4\pi R^2 \gamma = 17.9439 (1 - 1.7826 I^2) A^{2/3} \text{ MeV} \quad . \quad (48)$$

The nominal formula for the fissility parameter follows as

$$x = \frac{Z^2/A}{50.88303 (1 - 1.7826 I^2)} \quad . \quad (49)$$

If the radius R is written as $r_0 A^{1/3}$, where r_0 is a constant, the nominal value of r_0 implied by eq. 47 is

$$r_0 = \frac{3}{5} \frac{e^2}{0.7053 \text{ MeV}} = 1.224992 \text{ fm} . \quad (50)$$

Here e^2 , equal to 1.439978 MeV fm, is the square of the electric charge on the proton.

The nominal value of the surface energy coefficient, implied by eq. 48, is

$$\begin{aligned} \gamma &= \frac{17.9439 (1-1.7826 I^2) \text{ MeV}}{4\pi r_0^2} \\ &= 0.951569 (1-1.7826 I^2) \text{ MeV fm}^{-2} . \end{aligned} \quad (51)$$

These are nominal values, appropriate to the model in question, and ensuring that ground state masses, fission barriers, and (after inclusion of shell effects) nuclear ground-state masses and deformations will be reproduced approximately when the semi-empirical treatment described in Ref. 16 is used.

The deformation-energy maps to be described in the next section display the dimensionless quantity $\xi(\Delta, \rho, \lambda)$ at a series of values of the dimensionless parameter x . The maps are "universal" in the sense of being independent of the numerical values of the nuclear parameters. Two of the labels on the maps, however, ("LENGTH" and "ENERGY") refer to units of length and energy necessary for converting the dimensionless shape dimensions and energies into fermis and MeV, and they do depend on the nuclear parameters. These units (and other properties) were calculated for nuclei lying on Green's approximation to the valley of beta stability, specified by

$$I = \frac{0.4 A}{200 + A} . \quad (52)$$

Given the mass number A for a nucleus on this valley of stability, one may then calculate I , and since Z follows from

$$Z = \frac{1}{2} A (1 - I) , \quad (53)$$

the fissility parameter (and any other property of interest) may be calculated directly. The inverse problem, finding A, Z, I for a nucleus on the valley of stability for which the fissility x is specified, is less trivial. Thus, eliminating A, Z between eqs. 49, 52, 53 leads to the following cubic equation for I

$$a_0 I^3 + a_1 I^2 + a_2 I + 1 = 0 , \quad (54)$$

where $a_0 = 2.5 (\kappa - k) ,$

$$a_1 = 5k - \kappa ,$$

$$a_2 = -2.5(1 + k) ,$$

and κ stands for 1.7826 and k stands for $50/(50.88303x)$.

The relevant solution of eq. 54 may be written as

$$I = \left[2\sqrt{-q} \cos\left(\frac{1}{3} \tan^{-1} \frac{W}{U}\right) - \frac{a_2}{3} \right]^{-1} , \quad (55)$$

where

$$q = \frac{1}{3} a_1 - \frac{1}{9} a_2^2 ,$$

$$U = \frac{1}{6} a_1 a_2 - \frac{1}{2} a_0 - \frac{1}{27} a_2^3 ,$$

$$W = \sqrt{-q^3 - U^2} .$$

Once I is found, A, Z, N , etc. follow trivially.

Using the above equations we have listed in Table I the values of $A, Z, N, I, E_S^{(0)}, E_C^{(0)}, R$ for 60 nuclei with x values from 0.05 to 1.5.

6. The Maps

There are altogether 815 maps in four appendices, with page numbers A-1 to A-50, B-1 to B-50, C-1 to C-50, and D-1 to D-665. The odd pages in appendix A

display the scale function S , the even pages the quadrupole moment Q .

Appendix B displays the moments of inertia: $\mathcal{J}_\perp/\mathcal{J}_0$ on the odd pages and $\mathcal{J}_\parallel/\mathcal{J}_0$ on the even pages. The odd pages in appendix C gives maps of the quantity $G-1$ and the even pages display $F-1$.

Each map refers to a fixed asymmetry Δ , listed at the top of the page and ranging from $\Delta = 0$ to $\Delta = 0.6$ in steps of 0.025. In appendix D this is followed by the "fractional" asymmetry, i.e. the fraction of the total mass (or charge) residing in the larger of the two fragments after scission or, more generally, the ratio $R_1^3/(R_1^3+R_2^3)$. Using eqs. 14,15 this is related to Δ by

$$\text{"FRACTIONAL"} = \frac{R_1^3}{R_1^3+R_2^3} = \frac{(1+\Delta)^3}{2+6\Delta^2} . \quad (56)$$

The largest value of Δ , equal to 0.6, thus corresponds to a mass or charge ratio of 1 : 0.0156, e.g. a target nucleus with atomic number 100 bombarded with (or emitting) a particle with atomic number 1.56 (somewhat smaller than an alpha particle).

The maps display, as functions of ρ and λ , contours of equal values of the quantity in question (S , Q , $\mathcal{J}_\perp/\mathcal{J}_0$, $\mathcal{J}_\parallel/\mathcal{J}_0$, $G-1$, $F-1$, and ξ). The contours are not labeled. In order to deduce the numerical value that a contour refers to, one should locate the two reference points, the sphere at $\rho = \Delta$, $\lambda = 1-\Delta$ (this is the angled tip of the maps on the left), and the tangent spheres at $\rho = 1$, $\lambda = 0$. The legend at the top of the map gives, under "SPHERE" and "TANGENT", the values of the quantity in question at these points. For example, in the case of the scale function for $\Delta = 0.2$ (p.A-17), the value of S for the sphere is 1.66667 and for tangent spheres it is 1.52855. Since the spacing between contours (as given by the legend "SPACING") is 0.010 in this case, it is clear that the two contours nearest to

the point $\rho = 1$, $\lambda = 0$ must correspond to 1.52 and 1.53, with the latter referring to the contour value on the left, since S is increasing towards the sphere. Moving up along the boundary $\lambda = 1 - \rho$ and counting off the contours, one confirms that the thicker lines correspond, as one might expect, to the round numbers 1.55, 1.60, 1.65, and that the last contour before the tip corresponding to the sphere is 1.66, as it should be. (Owing to the nature of the contour-plotting routine, small pieces of a contour approaching a non-rectangular boundary are usually missing, so it could happen that this check would be slightly off). In the case of the maps of ξ , a further reference point is often available under the legend "SADDLE". For example, the map for $\Delta = 0.2$, $x = 0.5$ (p. D-313) exhibits an easily discernible saddle near $\rho = 1.5$, $\lambda = 0.4$, whose energy is listed as "SADDLE .10437". Since the spacing between contours is 0.005 in this case, this identifies the two thick contours near the saddle as corresponding to $\xi = 0.100$ and the two thin contours as $\xi = 0.105$. This identification is confirmed by counting off the contours either towards the sphere or tangent spheres. In the case of the maps for the energy ξ , it sometimes happens that one reaches the zero contour, $\xi = 0$, not exactly at the spherical shape. This is a consequence of the inaccuracy in the numerically calculated value of the relative electrostatic energy, G . Even though this inaccuracy is only a small fraction of one percent, it tends to show up as a quite noticeable displacement of an isoenergy contour in cases--such as the neighborhood of the sphere--where the energy is stationary and the deformation-energy landscape almost flat. (For example, on p. D-366, the thick contour near the left-hand edge refers to $\xi = 0$ and ought to have been exactly on this edge, which corresponds to the sphere.)

Each energy map is labeled by a value of the fissility x and asymmetry Δ . The values of x range from $x = 0.05$ to $x = 1.5$ in steps of 0.05 for $x < 0.6$

and $x > 1.0$, and in steps of 0.025 in the interval $0.6 < x < 1.0$. The arrangement of the maps is such that, for a given x , successive values of Δ appear on pages stacked behind one another. For example, starting on p. D-385, one has $x = 0.6$ and $\Delta = 0$. Turning the page, one has immediately under it the case of $\Delta = 0.025$ on the next odd page, D-387. Continuing to turn the pages, successive sections of the configuration space, taken at increasing values of the asymmetry, appear stacked behind one another, just as in Fig. 4. This continues up to the highest asymmetry for the given value of x (equal to 0.55 for $x = 0.6$), after which the sequence of maps for the next value of x begins. This continues up to p. D-665, which finishes off the sequence of maps for $x = 0.725$. The sequence for the next x -value, equal to 0.750, begins on p. D-664, the even page facing page D-665. Turning the pages back one by one again reveals sections of the configuration space taken at increasing values of Δ . The sequence for the highest x -value, equal to 1.5, comes to an end on p. D-2. A similar stacking scheme operates in the case of the simpler maps in Appendices A, B, C.

The energy maps in Appendix D cover a domain in the parameter space of x and Δ shown in Fig. 9. The boundaries are governed approximately by the principle that the maps should cover the range of conditions that can be achieved by bringing together any two nuclei in the periodic table (from about the alpha particle to the heaviest elements). It then turns out that, for x -values up to about 0.95, the upper bound on Δ (for a given x) is reached when the smaller fragment decreases below about mass number 4. For x -values greater than about 0.95, the upper bound on Δ is reached when the larger fragment becomes heavier than the heaviest element in the periodic table. (In estimating these bounds the total system is always assumed to be close to Green's valley of beta-stability.)

7. Saddle-point Properties

Configurations of special interest are those for which the energy ξ is stationary with respect to small variations of the shape parameters. If the energy is stationary with respect to all the degrees of freedom defining the problem at hand (in our case Δ, ρ, λ), we have unconditional configurations of equilibrium (minima, saddles, mountain tops). If the energy is stationary, but only under the condition that some shape parameter (or parameters) is held fixed, we have conditional configurations of equilibrium, the equilibrium being conditional on the freezing of some parameter(s). Unconditional equilibrium shapes are invariant to a change of coordinates (e.g. from Δ, ρ, λ to some functions Δ', ρ', λ' of Δ, ρ, λ). Conditional equilibrium shapes are not invariant to a change of coordinates (it obviously matters, in general, whether Δ or Δ' --a function of Δ, ρ, λ --is frozen) and their relevance is in proportion to the physical significance of the freezing of the given parameter(s).

Our energy $\xi(\Delta, \rho, \lambda)$ is stationary to small variations of Δ, ρ, λ for five types of configurations: the sphere, two equal spheres at infinite separation, two unequal spheres at infinity (if $x > 0.2$), the reflection symmetric Bohr-Wheeler saddle-point shapes and the asymmetric Businaro-Gallone saddle shapes (cousins of the unequal spheres at infinity). In addition, when $x = 0$, two equal spheres at any separation (from infinity up to tangency) have a stationary energy. (See Ref. 17 Fig. 39 and Ref. 18 for surveys of such equilibrium shapes.)

The most important family of equilibrium shapes is the Bohr-Wheeler family of saddle-points, whose energy (with respect to the sphere) defines the barrier energy against binary symmetric fission. The family starts as equal tangent spheres at $x = 0$ and, through a series of hour-glass figures,

cylinders with rounded ends, and spheroids of decreasing eccentricity, becomes a sphere at $x = 1$. This sequence can be traced as a function of x in the maps of ξ appropriate to symmetric shapes with $\Delta = 0$. In addition, various properties of these saddle shapes are listed on the first page of Table II, in the range $x = 0.3$ to $x = 0.9$. The remaining pages of Table II refer to conditional and Businaro-Gallone saddles. For each value of x (listed in the first column), there follow two lines of numbers (22 entries altogether) giving the following characteristics of the saddle shapes:

BARRIER:	The (dimensionless) energy ξ of the saddle shape, in units of the surface energy of the sphere.
SURFACE:	The dimensionless relative change in the surface energy, denoted by (F-1) in section 6.
COULOMB:	The dimensionless relative change in the electrostatic energy, denoted by (G-1).
RHO:	The ρ -coordinate of the saddle-point in the ρ - λ plane.
LAMBDA:	The λ -coordinate of the saddle-point in the ρ - λ plane.
INPERP:	The (dimensionless) moment of inertia of the saddle-point shape, $\mathcal{I}_\perp/\mathcal{I}_0$, taken about an axis through the center of mass and at right angles to the axis of symmetry and expressed in units of the moment of inertia of the sphere.
INPAR:	The (dimensionless) moment of inertia about the axis of symmetry, denoted by $\mathcal{I}_\parallel/\mathcal{I}_0$.
QUADRUPOLE:	The mass quadrupole moment of the saddle-point shape in units of the quantity: (total mass)(standard radius R) ² .
R1,R2:	The radii R_1, R_2 of the two spheres defining the outer parts of the saddle shape, in units of the standard radius R.

SCALE:	The sum of R_1 and R_2 . Multiplication by SCALE converts a linear dimension expressed in units of $(R_1 + R_2)$, such as ρ or λ , into a linear dimension expressed in units of the standard radius R.
Z1,Z2:	The coordinates of the junction points z_1 and z_2 of the first and second sphere with the middle quadratic surface, measured from the center of the first sphere, in units of the standard radius R.
Z CUT:	When the spheres do not overlap, this coordinate, measured as above, divides the distance between the centers of the two spheres in the ratio of their radii. When the spheres overlap, it is the z-coordinate locating their intersection.
FMASS:	The fractional mass, $M_1/(M_1+M_2)$, of the part of the saddle-point shape on the same side of Z CUT as sphere 1. For necked-in shapes this is approximately the fractional mass to one side of the neck (the region of minimum radius of the middle quadratic). It continues to provide a measure of asymmetry even when the neck has disappeared or has moved into the unphysical region outside the interval between z_1 and z_2 .
ZCM1,ZCM2:	The coordinates (with respect to the center of sphere 1 and in units of the standard radius R) of the centers of mass of the two portions of the shape, one on the same side of Z CUT as sphere 1, the other on the same side as sphere 2.
COMPACT:	The difference between ZCM2 and ZCM1. This is a measure of compactness of the saddle shape.

- OPENING: This is α , the degree of opening of the neck (window) between the two halves of the shape, given by $[1-(1-\lambda)\rho]/(1-\Delta^2)$.
- ANGLE: When the potential energy expression in the vicinity of the saddle-point (at fixed Δ) is brought to principal axes in the ρ, λ plane, the anticlockwise rotation (in degrees) from the $\rho-\lambda$ coordinates to those axes is given by "ANGLE". (See below.)
- STIFF1,STIFF2: The stiffness of the potential energy in the vicinity of the saddle with respect to normal coordinate displacements. Thus the potential energy change, $\xi - \xi_{sp}$, for a point whose small displacement from the saddle-point location is specified by $(\rho - \rho_{sp}, \lambda - \lambda_{sp})$, is
- $$\xi - \xi_{sp} = (\text{STIFF1})[(\lambda - \lambda_{sp}) \sin(\text{ANGLE}) + (\rho - \rho_{sp}) \cos(\text{ANGLE})]^2 + (\text{STIFF2})[(\lambda - \lambda_{sp}) \cos(\text{ANGLE}) - (\rho - \rho_{sp}) \sin(\text{ANGLE})]^2$$

Note that, by symmetry, the asymmetry displacement Δ must be decoupled, for the Bohr-Wheeler saddle shapes, from the displacements $\lambda - \lambda_{sp}, \rho - \rho_{sp}$, so that Δ is, in fact, the third principal-axis displacement for those shapes. For a given x , the associated stiffness, STIFF3, may be estimated by fitting a quadratic to the barrier energies (listed under BARRIER) for conditional saddle shapes differing from the Bohr-Wheeler saddle by small values of Δ .

After the Bohr-Wheeler saddles on the first page of Table II, follow the analogous conditional saddles at fixed asymmetry, for $\Delta = 0.025, 0.05 \dots 0.475$. Up to $\Delta = 0.150$, they behave qualitatively like the Bohr-Wheeler shapes: an elongation with increasing x up to about $x \approx 0.7$ followed by a

contraction and drift toward the sphere. For $\Delta = 0.175$ and higher, the reversal in the elongation is absent. This is associated with the simultaneous presence, in those cases, of two additional families of conditional equilibrium: a more compact saddle shape, analogous to the contracting part of the Bohr-Wheeler shapes and a conditional minimum (a shape that would be stable under the restriction imposed by our parametrization together with the freezing of the asymmetry Δ). This can be seen, for example, on p. D-346 for the case of $x = 0.9, \Delta = 0.25$. In this map of the potential energy there are two saddles, at $\rho = 2.6066, \lambda = 0.6496$, and $\rho = 0.58, \lambda = 1.32$, as well as a minimum, somewhat beyond the edge of the map near $\rho = 3, \lambda = 0.91$. (See also section 8.) In cases when three conditional equilibrium shapes are present, Table II lists only the properties of the most necked-in one, where the condition of a frozen asymmetry Δ is most likely to be physically relevant.

The last page of Table II lists the properties of the Businaro-Gallone shapes of unconditional equilibrium. In this table the first column is the value of x and the second is the asymmetry Δ of the Businaro-Gallone shape for that x -value. The other entries are as before. Note the remarkable feature of our Δ, ρ, λ parametrization that the ρ and λ values of the Businaro-Gallone shapes turn out to be almost independent of x . Thus $\rho = 1.484 \pm 0.005, \lambda = 0.354 \pm 0.004$, would bracket almost all the tabulated values of ρ and λ . A consequence of this is that the stiffness of the potential energy of a Businaro-Gallone shape with respect to changes in Δ , i.e. "STIFF3", can be estimated by fitting a parabola to a few neighbouring values of the energy at the standard location $\rho = 1.484, \lambda = 0.354$, and with Δ differing by $\pm 0.025, \pm 0.050$, etc. In effect, even though the variable Δ is not a principal axis of the potential-energy expression in the neighbourhood of a Businaro-Gallone

shape by virtue of any symmetry properties, it happens to be very close to the principal axis in our Δ, ρ, λ parametrization.

The relative dimensionless energy ξ for the Bohr-Wheeler and Businaro-Gallone shapes is plotted as a function of x in Fig. 10. The energies ξ of the Bohr-Wheeler saddles and of conditional saddles for $\Delta = 0.1, 0.15, 0.2, 0.25, 0.3, 0.35, 0.4, 0.45$ are shown in Fig. 11. Figure 12 is a test of the accuracy of the scaling rule of Ref. 15. According to this rule, the energy η of conditional saddles at an asymmetry Δ , taken with respect to the energy of tangent spheres and expressed in units of (twice) the surface energy of a sphere whose radius R is the "reduced radius" \bar{R} of the system [$\bar{R} = R_1 R_2 / (R_1 + R_2)$], should be a universal function of the "effective fissility parameter", x_{eff} , where

$$x_{\text{eff}} = x \frac{(1-\Delta)^2}{1+3\Delta^2} .$$

This scaling rule is based on the small-neck (i.e. small x_{eff}) approximation to saddle-point shapes, but Fig. 12 shows that it continues to hold in a rough way even for higher values of x_{eff} , where some of the saddle-point shapes are not necked in at all!

Figures 13,14 display the Businaro-Gallone shapes for $x = 0.4, 0.45, 0.5, 0.6, 0.7,$ and 0.8 . Beyond $x \approx 0.7$, the present parametrization becomes rapidly inadequate for the description of these shapes. Thus, the Businaro-Gallone family is believed to come to an end near $x = 0.8$ (Refs. 11,19), where it doubles back on itself, so that for $x \lesssim 0.8$ there exists yet another family of equilibrium shapes (with one more degree of instability than the Businaro-Gallone shapes, i.e. three degrees instead of two). The physical meaning of this is that at about $x \approx 0.8$ the larger of the two pieces of the Businaro-Gallone shape becomes unstable against fission in

the presence of the perturbation caused by the smaller piece. Below the critical value $x \approx 0.8$ the Businaro-Gallone shape is stable against such a disintegration (involving the elongation of the larger piece and an eventual formation of a second neck). In those cases, the saddle point guarding the Businaro-Gallone shape against such a disintegration is the new equilibrium family. With decreasing x these shapes are expected to tend to a figure with two necks, eventually ending up as three equal tangent spheres at about $x \approx 0.6$ (?) (see Fig. 39 in Ref. 17). Our binary, single-neck parametrization is intrinsically incapable of following this sequence of equilibrium shapes. The relation to each other of these families of equilibrium shapes is illustrated in Fig. 15. [The loss of stability against fission near $x \approx 0.8$ of the larger lobe of a Businaro-Gallone shape, has its counterpart in the astronomical problem of idealized rotating gravitating masses. There the "Roche limit" refers to a critical configuration where the smaller one of two orbiting masses becomes unstable against disintegration in the presence of the (tidal) perturbation caused by the larger one.]

8. Illustrative Examples

Table III lists, in the first column, a number of reactions between pairs of nuclei that have recently received much attention. The second column gives the asymmetry Δ , estimated on the basis of the atomic numbers Z_1, Z_2 , i.e. assuming that the radii R_1, R_2 are proportional to $Z_1^{1/3}, Z_2^{1/3}$. Thus

$$\Delta = \frac{Z_1^{1/3} - Z_2^{1/3}}{Z_1^{1/3} + Z_2^{1/3}} .$$

The third column gives the fissility parameter x for the total system (eq. 49). The last column gives the page number of the most nearly relevant

potential-energy map in Appendix D, obtained by rounding Δ and x to the nearest quarter unit in the first decimal place. Because of this rounding and because the systems considered are not exactly on the valley of beta stability, a given map is only approximately relevant for the system in question.

The first seven reactions in Table III were the subject of studies in Refs. 20,21, from which it appears that, as the lighter partner in a collision with ^{208}Pb is increased from ^{26}Mg to ^{64}Ni , automatic fusion on contact gives place, somewhere around ^{48}Ca or ^{50}Ti , to reseparation (unless an extra push--an extra bombarding energy over the interaction barrier--is provided). Glancing through the sequence of maps on pp. D-542, D-448, D-398, D-350, D-300, D-302 one does, indeed, gain the immediate impression that a system started off from rest at contact (i.e. at $\rho = 1$, $\lambda = 0$) would readily fuse in the case of the first two reactions (p. D-542) but would probably reseparate (by first increasing λ and then veering off toward increasing ρ) in the case of the seventh reaction (with ^{64}Ni). Even the existence of a transition region near ^{48}Ca or ^{50}Ti might have been guessed merely by inspection of the potential-energy maps.

It is interesting to note that with our (restricted) parametrization and with the asymmetry Δ frozen, the systems corresponding to maps D-448, D-398, D-350 and D-300 possess a conditional minimum for elongated shapes near the right-hand edge of the maps. If a system were trapped in such a minimum, it could only redivide by changing its asymmetry. In all the cases mentioned there is, indeed, a driving force in the direction of decreasing asymmetry, for configurations in the vicinity of the minimum. This may be verified by comparing successive maps at a given x and different asymmetries (by simply flipping the pages). The minima are, therefore, conditional but not unconditional (true) equilibrium shapes.

The eighth reaction in Table III was used recently to make a few atoms of element 107 (Ref. 22) and the ninth is a candidate reaction for making a superheavy element. In the former the production of a compound nucleus may have been helped by a deformed ground state, associated with a local dimple in the potential energy landscape, the result of nuclear shell effects (not displayed on our maps). In the latter case the shell-effect dimple is expected to be around the spherical shape, all the way on the left of the map on p. D-196.

The last line in Table III refers to the case $\Delta = 0.25$, $x = 0.9$ (approximately a reaction like $^{226}\text{Ra} + ^{41}\text{K}$). The associated potential-energy map on p. D-346 is typical of reactions in this range of Δ and x values, and some details of relevant shapes are given in Figs. 1,2,3. Thus Fig. 1a shows the tangent configuration and Fig. 1b shows the compact conditional saddle shape in the vicinity of $\rho = 0.58$ and $\lambda = 1.3190$ (where the central spheroid has just covered the smaller sphere). Figure 2a gives some indication of the appearance of the conditional minimum, which is somewhat beyond the edge of the map and therefore even more elongated than the shape in Fig. 2a, with $\rho = 3$, $\lambda = 0.91$. If such a shape were obliged to disintegrate within our restricted parametrization and at fixed Δ , it would have to find its way over the saddle-point pass at $\rho = 2.6066$, $\lambda = 0.6496$, shown in Fig. 2b. [From the ξ -values for these shapes and the caption "ENERGY" on p. D-346, we deduce that the barrier opposing such disintegration would be about $(0.00004 + 0.0155)(695.85 \text{ MeV}) = 10.81 \text{ MeV}$.] Figure 3a illustrates a scission shape with the same value of ρ as the saddle point in Fig. 2b and with $\lambda = 0.6164$. Figure 3b shows a post-scission shape resulting from decreasing λ further to 0.52.

9. Limitations

We hope that the present maps, relevant for idealized nuclei, will be found useful in advancing our understanding of the statics and dynamics of real nuclear processes. This usefulness will be enhanced if the serious limitations of the maps are clearly realized and kept in mind. Of these limitations we would like to mention especially the following:

a) The maps refer to nuclei idealized as sharp-surfaced systems. The sharpness of the surface (and the associated neglect of the finite range of nuclear forces) results in a particularly inadequate description of the energy of two nuclei in close proximity and of systems with small necks. The modifications to our potential-energy maps due to these effects would be particularly pronounced near the contact point ($\rho = 1$, $\lambda = 0$) and along the scission line ($\lambda = 1 - \rho^{-1}$). An estimate of the modification along the lower edge of the maps (for $\lambda = 0$ down to $\rho = 1$ and along the sloping line $\lambda = 1 - \rho^{-1}$) may be obtained by a judicious use of the Proximity Potential from Refs. 23,24. In doing this one should remember the limited applicability of the proximity potential itself (to nearly parallel crevices and gaps) and the fact that the illustrative nuclear parameters suggested in section 5 were designed to reproduce approximately average nuclear energies in the absence of a proximity contribution. Hence, away from regions where the shapes have well-defined gaps or crevices, any sizable corrections implied by a formal application of the proximity method should probably be disregarded. As a rough rule, the peaked mountain usually appearing in our maps at $\rho = 1$, $\lambda = 0$ should be imagined as smoothed out to a rounded hill. The rather sharp ridge along the scission line should also be imagined as somewhat smoothed out.

b) Our three-degrees-of-freedom parametrization of nuclear shapes by two spheres and a third quadratic is quite restrictive. For compact shapes,

or for shapes where there is no necking or only a single neck, the resulting limitations may not be serious or may be only quantitative. However, for shapes where two necks come into question, the limitations become qualitative and could easily be misleading. One example is the fate of the Businaro-Gallone shapes, discussed in section 7. Another qualitative shortcoming would probably show up in a discussion of the possible disintegration modes of very elongated shapes, such as the one in Fig. 2a. As such cylinder-like shapes become longer and longer, ternary, quaternary and higher division modes are known (qualitatively) to come up for consideration. Our parametrization is intrinsically unable to accommodate them and could be grossly misleading if these limitations were underrated.

c) The parametrization is restricted to axially symmetric shapes and there is no possibility of discussing bending or wriggling deformations or triaxial shapes.

d) Within the boundaries of our maps we have no flattened shapes--for example, no single oblate spheroid nor two approaching nuclei, flattened under the influence of the electrostatic repulsion.

e) Our idealized Liquid Drop nuclei have not only sharp surfaces, but a uniform electric charge density assumed proportional at each point to the mass density. As a result, all the effects associated with the Droplet Model [charge redistribution, neutron skin, etc. (Ref. 25)] are absent.

f) Even more important, of course, is the absence of shell effects in our potential-energy maps. In cases when large shell effects are expected, it is particularly important to remember that our maps provide only the average background, on top of which the shell effect oscillations should be superimposed. In situations where shell effects are less pronounced (for example, at excitation energies of some tens of MeV), the maps may be more nearly relevant, as they stand, for semi-quantitative estimates.

Acknowledgements

We started work on this atlas of nuclear potential energy maps almost ten years ago, and in that time we have benefited from interactions with many colleagues in our home institutions. We would also like to thank W. Johnston of the Computer Graphics Laboratory at LBL for help with adapting to our needs the contour plotting routines used in making all the maps. This work was supported by the Director, Office of Energy Research, Division of Nuclear Physics of the Office of High Energy and Nuclear Physics of the U.S. Department of Energy under Contract DE-AC03-76SF00098.

References

1. W.D. Myers and W.J. Swiatecki, "The Macroscopic Approach to Nuclear Masses and Deformations", Lawrence Berkeley Laboratory preprint LBL-13929, March 1982, to be published in Annual Review of Nucl. and Particle Science, 32 (1982) 309.
2. J. Randrup and W.J. Swiatecki, Ann. Phys. 125 (1980) 193.
3. W.J. Swiatecki, Progr. in Particle and Nucl. Science 4 (1980) 383.
4. S. Cohen and W.J. Swiatecki, Ann. Phys. 22 (1963) 406.
5. V.M. Strutinsky, N. Ya. Lyashchenko and N.A. Popov, Soviet Phys. JETP 16 (1963) 418; J. Exptl. Theoret. Phys. (U.S.S.R.) 43 (1962) 584; Nucl. Phys. 46 (1963) 639.
6. P. Möller and J.R. Nix, Nucl. Phys. A281 (1977) 354.
7. S. Trentalange, S.E. Koonin and A.J. Sierk, Phys. Rev. C22 (1980) 1159.
8. S. Bjørnholm and W.J. Swiatecki, Phys. Reports 4C (1972) 6.
9. W.J. Swiatecki, Journal de Physique, Colloque C5, supplement no. 8-9, Vol. 33, August-September 1972.
10. J.R. Nix and W.J. Swiatecki, Nucl. Phys. 71 (1965) 1.
11. J.R. Nix, Nucl. Phys. A130 (1969) 241.
12. J.R. Nix and A.J. Sierk, Phys. Rev. C15 (1977) 2072.
13. H.J. Krappe, J.R. Nix and A.J. Sierk, Phys. Rev. C20 (1979) 992.
14. J. Błocki, Y. Boneh, J.R. Nix, J. Randrup, M. Robel, A.J. Sierk and W.J. Swiatecki, Ann. Phys. 113 (1978) 330.
15. W.J. Swiatecki, Physica Scripta 24 (1981) 113.
16. W.D. Myers and W.J. Swiatecki, Proc. of the Lysekil Symposium, Ark. Fys. 36 (1967) 343.
17. S. Cohen and W.J. Swiatecki, Ann. Phys. 19 (1962) 67.

18. W.J. Swiatecki, Proc. International Colloquium on Drops and Bubbles, D.J. Collins, M.S. Plesset, M.M. Saffren, Editors, California Inst. of Technology and Jet Propulsion Laboratory, 1974, Vol. I, p. 52.
19. J.R. Nix, Theory of Nuclear Fission and Superheavy Nuclei, Los Alamos preprint LA-DC-12488, April 1971, p. 13 and Fig. 16.
20. H. Sann, R. Bock, Y.T. Chu, A. Gobbi, A. Olmi, U. Lynen, W. Müller, S. Björnholm and H. Esbensen, Phys. Rev. Lett. 47 (1981) 1248.
21. W.J. Swiatecki, Nucl. Phys. A376 (1282) 275.
22. G. Münzenberg, S. Hofmann, F.P. Hessberger, W. Reisdorf, K.-H. Schmidt, J.R.H. Schneider, P. Armbruster, C.C. Sahm and B. Thuma, Z. Phys. A300 (1981) 107.
23. J. Björck, J. Randrup, W.J. Swiatecki and C.F. Tsang, Ann. Phys. 105 (1977) 427.
24. J. Björck and W.J. Swiatecki, Ann. Phys. 132 (1981) 53.
25. W.D. Myers, "Droplet Model of Atomic Nuclei", IFI/Plenum, 1977.

Figure captions

- Fig. 1. Examples of shapes described by our parametrization of two spheres joined by a quadratic surface of revolution. The values of the asymmetry coordinate Δ , the separation coordinate ρ and the "deck" coordinate λ are indicated. The dimensionless relative deformation energies ξ are given for a system with a fissility parameter $x = 0.9$. In b) the middle quadratic (a spheroid) has just swallowed up the smaller sphere. The center of the spheroid is indicated by a vertical bar. The unit of the scale on the ordinate and abscissa corresponds to the radius R of the standard sphere, with volume equal to the total volume of the given shape.
- Fig. 2. Same as Fig. 1 but for more elongated shapes. The middle quadratic is now a hyperboloid of one sheet. Its center is again indicated by a vertical bar (a distance c from the origin) and its junction points with spheres R_1 and R_2 are denoted by z_1 and z_2 . The dashed vertical line at $z = z_{cut}$ divides the distance, r , between the centers of the two spheres in the ratio of their radii.
- Fig. 3. Same as Figs 1 and 2 but for a scission shape a) and a post-scission shape b). In b) the left-hand fragment is a portion of a sphere fitted to a piece of a hyperbola of two sheets with tip at z_3 and center at c_1 . The second fragment is a scaled down image of the first, with simultaneous reflection about the center at c_1 .

Fig. 4. This is a perspective view of the configuration space in which Δ , ρ , and λ are cartesian coordinates (with Δ pointing away from the reader). Sections at $\Delta = 0, 0.2, 0.4, 0.6, 0.8$, and 1 help to visualize the shape of the "configuration box" to the inside of which are confined the shapes of interest. The whole box extends to infinity on the right and is reflection symmetric about the plane $\Delta = 0$. The nature of the shapes corresponding to various parts of the box are indicated by labels. The "ovoids" are egg-like shapes, tending to a sphere on the left and to long needles on the extreme right.

Fig. 5. A section of the configuration space at $\Delta = 0$. The dashed lines indicate where α , the relative degree of opening of the window between the two halves of the shapes, is 0, 25%, 50%, 75%, and 100%, respectively. The label "Binary Regime" refers to separated fragments, "Dinuclear Regime" to (substantially) necked-in shapes and "Mononuclear Regime" to shapes without a neck. In this, symmetric, case all of the ordinate between $\lambda = 1$ and $\lambda = 2$ corresponds to a spherical shape.

Fig. 6. Same as Fig. 5, but for $\Delta = 0.2$.

Fig. 7. Same as Fig. 5, but for $\Delta = 0.4$.

Fig. 8. Same as Fig. 5, but for $\Delta = 0.6$.

Fig. 9. The outline of the region in the Δ - x plane for which potential-energy maps are provided in Appendix D.

Fig. 10. The dimensionless deformation energy, ξ , of the Bohr-Wheeler and Businaro-Gallone shapes, as calculated in the present parametrization. The thin straight line on the left is the limiting behaviour of the Bohr-Wheeler energies as $x \rightarrow 0$. The dashed part of the Businaro-Gallone curve becomes inaccurate and its extension beyond $x \approx 0.8$, spurious. The correct behaviour is indicated (schematically) by the dotted curve.

Fig. 11. These are the dimensionless deformation energies of the conditional saddle-point shapes for $\Delta = 0.1, 0.15, 0.2, 0.25, 0.3, 0.35, 0.4, 0.45$. (The curve labeled $\Delta = 0$ refers to the Bohr Wheeler unconditional saddle shape.)

Fig. 12. The deformation energies from Fig. 11 are plotted in a way designed to test the "small-neck" scaling rule explained in the text. All the curves tend to a universal behaviour for small values of the effective fissility x_{eff} , where the scaling rule is exact. For larger values of x_{eff} the curves split up into two trends (beyond $x_{\text{eff}} \approx 2/3$): an upswing for the compact shapes tending to a sphere, and a continued downward trend for necked-in shapes. The short piece of the curves labeled $\Delta = 0.2$ (below the cusp at $x_{\text{eff}} \approx 0.66$) refers to the conditional minima discussed in the text. The fact that Fig. 12 is considerably more compact than Fig. 11 attests to the usefulness of the scaling rule, at least in the range of asymmetries and fissilities illustrated.

Fig. 13. The Businaro-Gallone shapes for $x = 0.4, 0.45, 0.5$. The vertical bar shows the location of the center of the hyperbolic neck and the cross indicates the center of mass of the whole figure.

Fig. 14. Same as Fig. 13, but for $x = 0.6, 0.7, 0.8$. The last figure is expected to be a very inaccurate representation of the true situation (see text).

Fig. 15. Some characteristic dimensions of the Bohr-Wheeler and Businaro-Gallone shapes (in units of the standard radius R). The neck radius (labeled R_{\min}) of the Bohr-Wheeler shapes starts from zero at $x = 0$ with a slope of 0.661 and reaches 1 at $x = 1$. The major semi-axis (labeled R_{\max}) starts with a value 1.5874 at $x = 0$, increases until about $x \approx 0.62$, and then drops to 1 at $x = 1$. The Businaro-Gallone family bifurcates off the Bohr-Wheeler family at $x \approx 0.4$. Its neck radius decreases with increasing x . Its two axes labeled R_{\max} and R_{med} correspond to the distances from the tips of the figure to the center of mass (indicated by a cross in Figs. 13, 14). The dotted curves indicate schematically the expected behaviour of the Businaro-Gallone family beyond the turning point at $x \approx 0.8$.

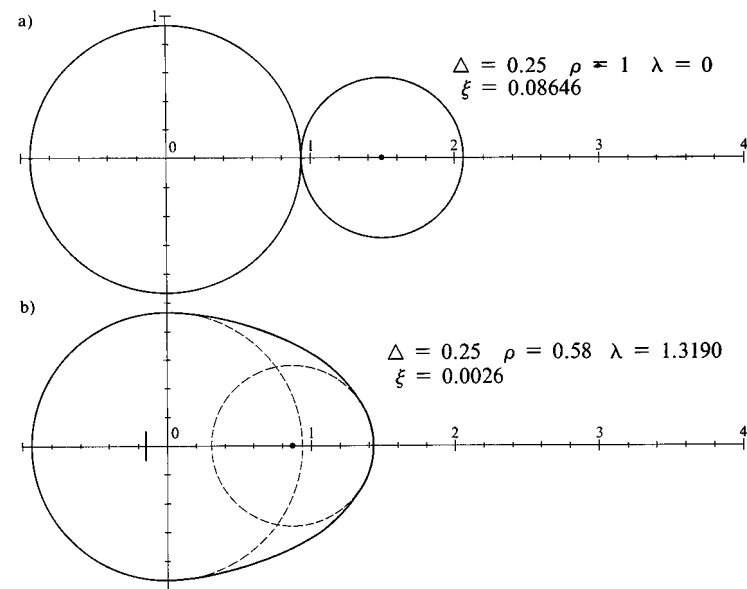

XBL 926-770

FIG. 1

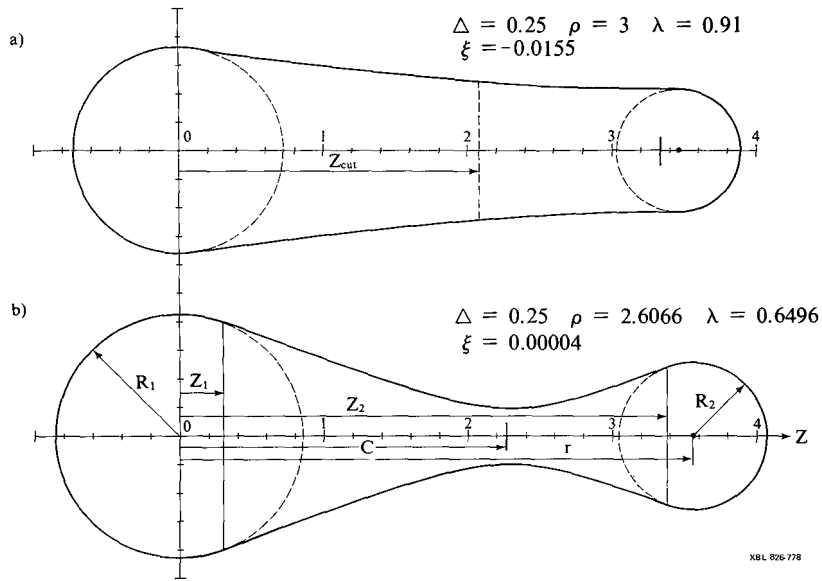

FIG. 2

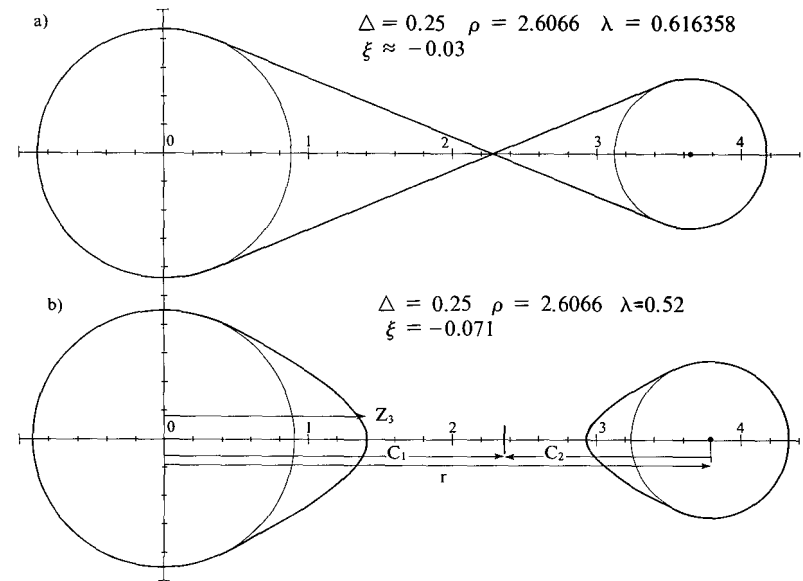
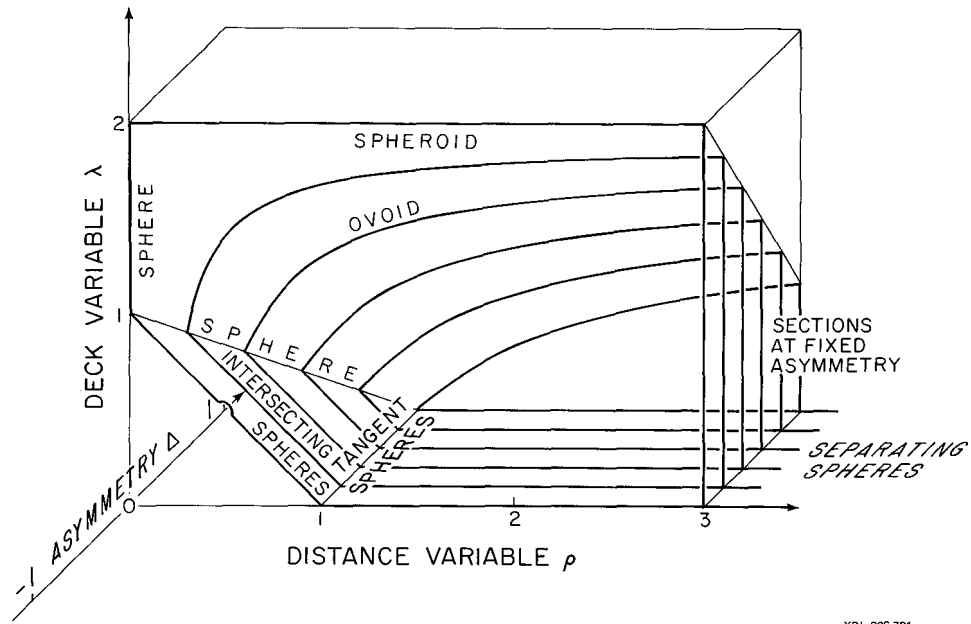
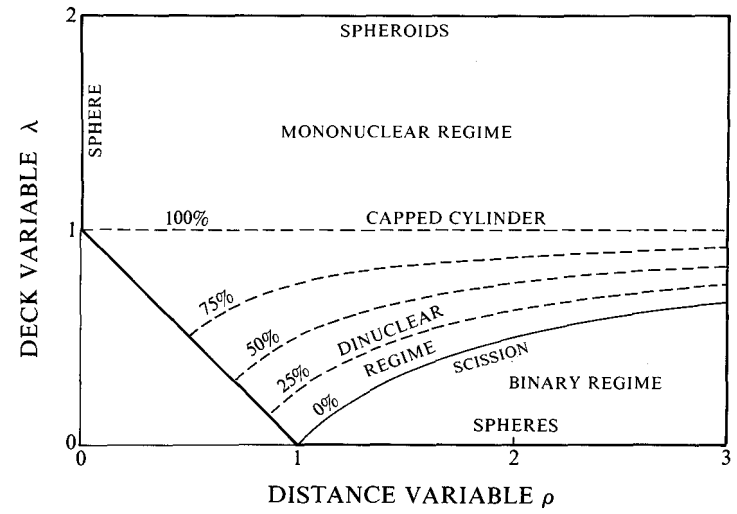

FIG. 3



XBL 826-781

FIG. 4



XBL 826-782

FIG. 5

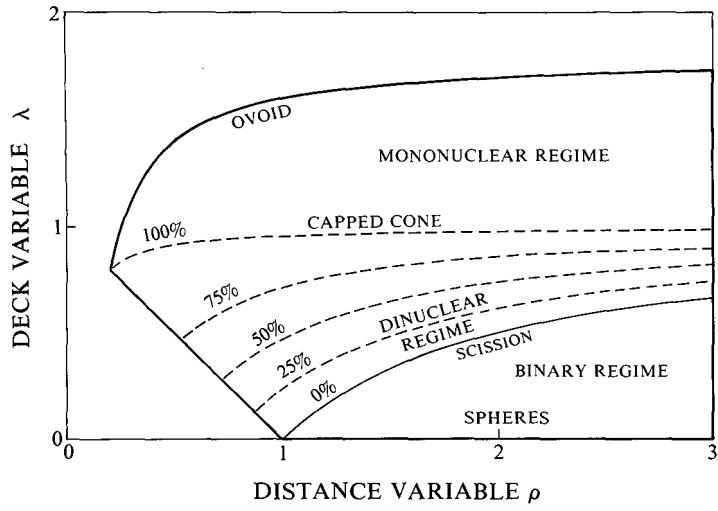

XBL 826-783

FIG. 6

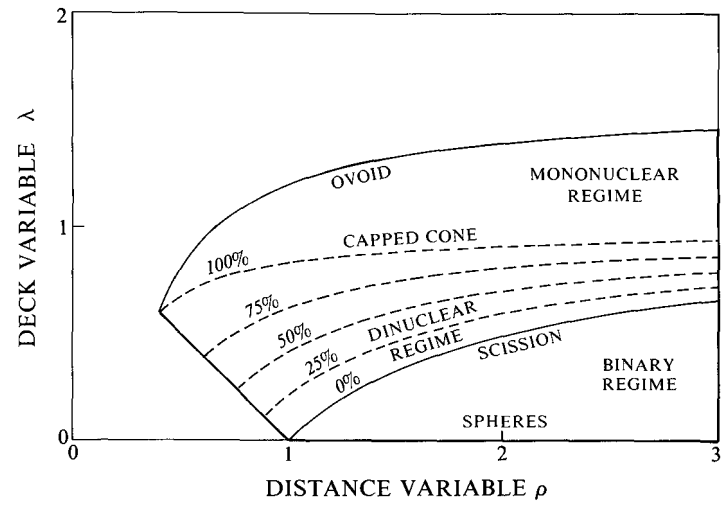

XBL 826-791

FIG. 7

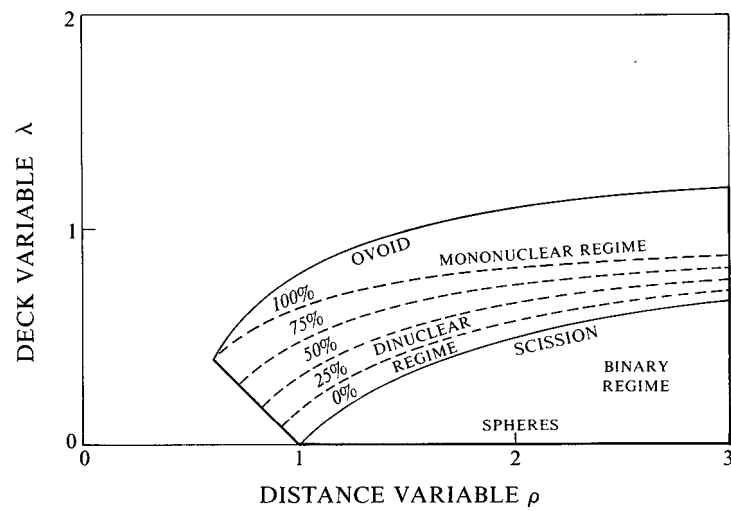

XBL 826-784

FIG. 8

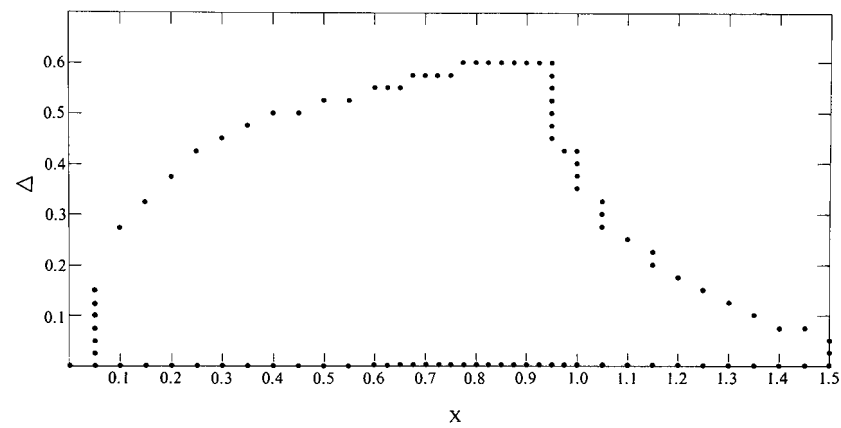

XBL 826-784

FIG. 9

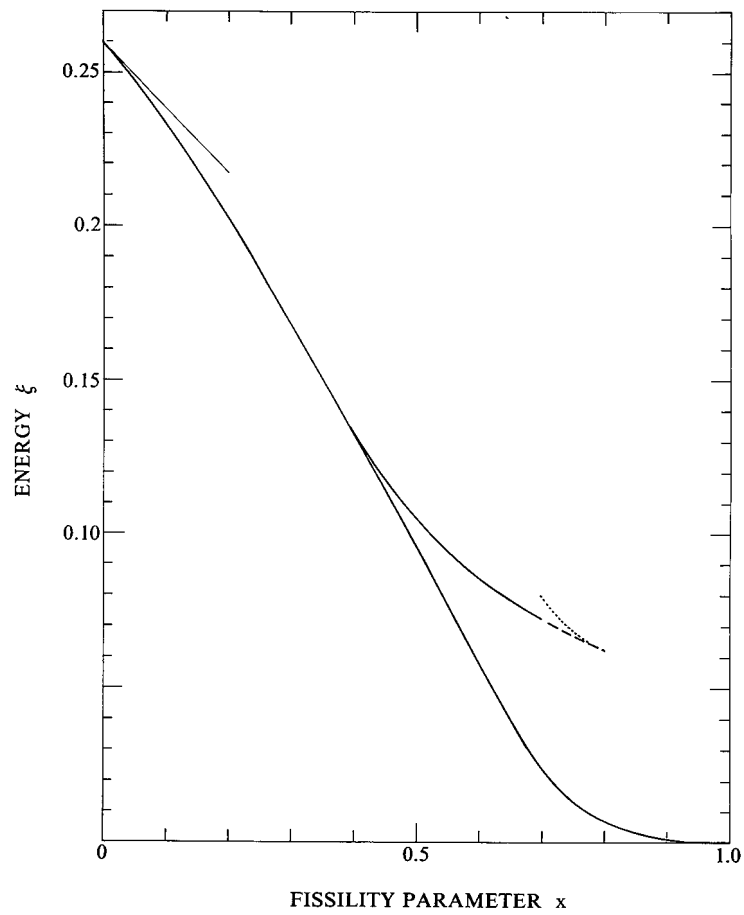

XBL 826-787

FIG. 10

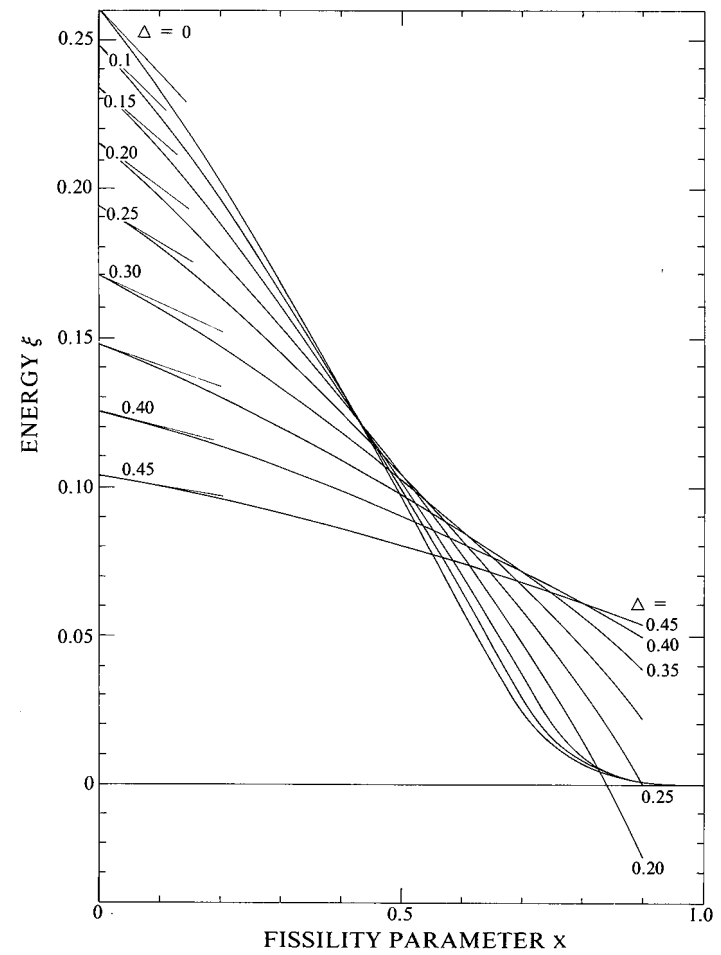

XBL 826-786

FIG. 11

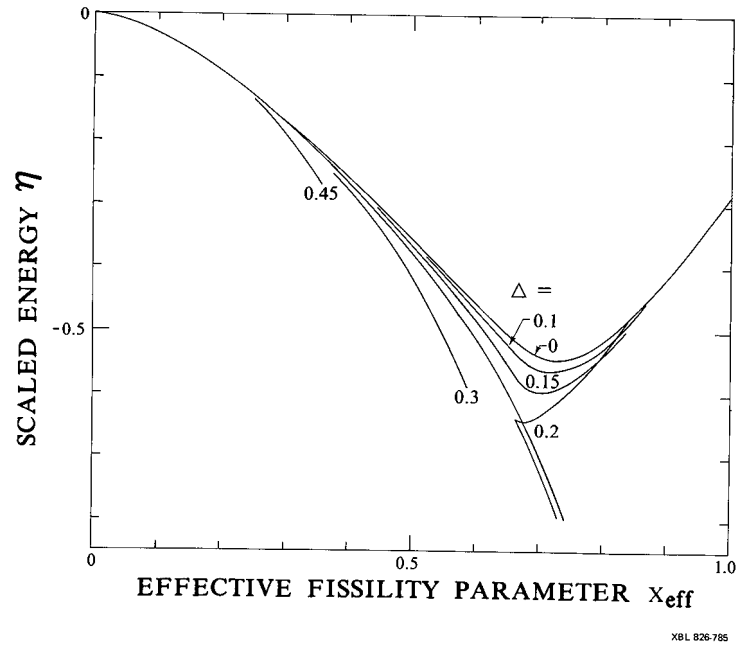

FIG. 12

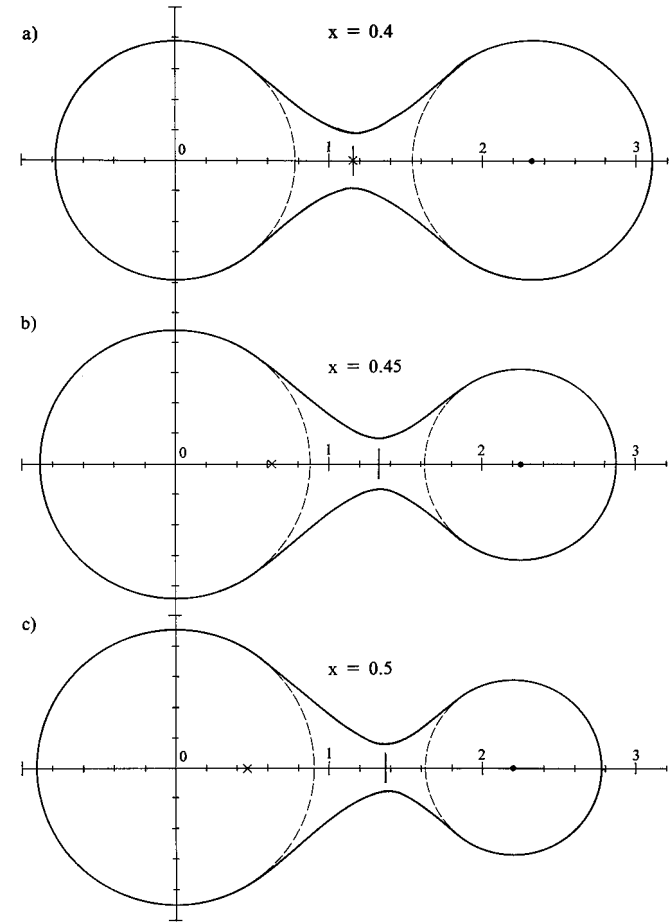
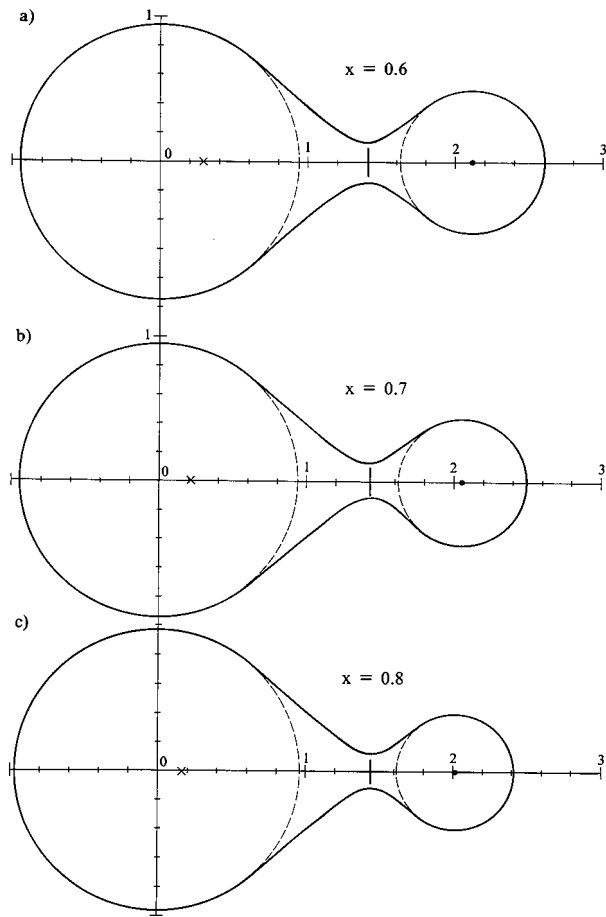
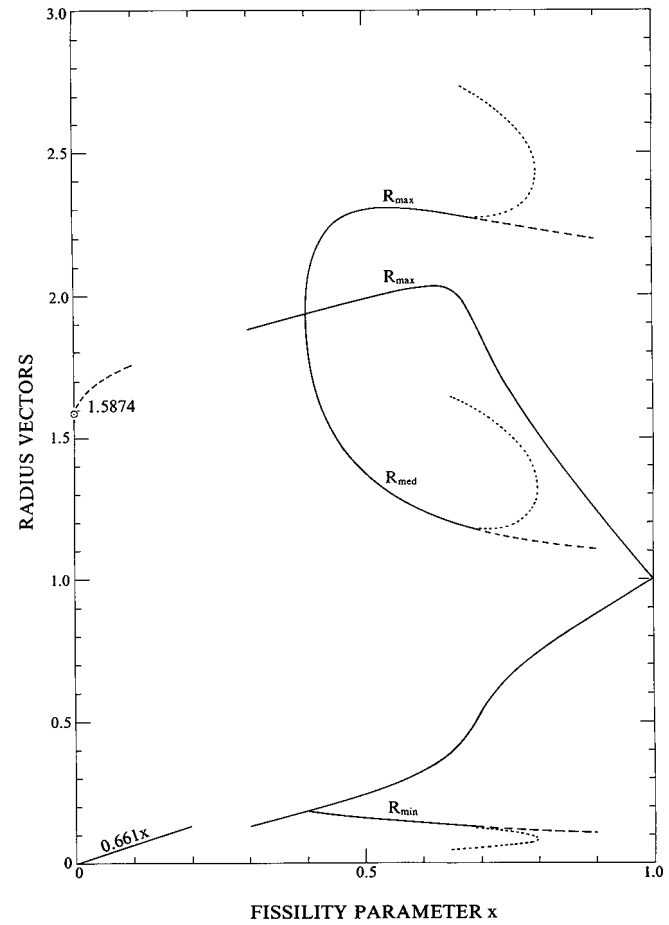

FIG. 13



XBL 826-789

FIG. 14



XBL 826-777

FIG. 15

Table I

Nuclear Properties Along Green's Valley of Stability

x	A	Z	N	I	$E_S^{(o)}$ (MeV)	$E_C^{(o)}$ (MeV)	R (fm)
0.050	10.591	5.189	5.402	0.020117	86.476	8.648	2.6902
0.075	16.197	7.856	8.341	0.029967	114.684	17.203	3.0994
0.100	22.007	10.567	11.440	0.039651	140.519	28.104	3.4328
0.125	28.019	13.321	14.698	0.049151	164.819	41.205	2.7206
0.150	34.228	16.114	18.115	0.058453	188.013	56.404	3.9774
0.175	40.632	18.944	21.688	0.067542	210.353	73.623	4.2114
0.200	47.223	21.808	25.416	0.076406	231.995	92.798	4.4278
0.225	53.997	24.703	29.295	0.085036	253.045	113.870	4.6301
0.250	60.947	27.627	33.321	0.093425	273.575	136.788	4.8208
0.275	68.066	30.577	37.490	0.101567	293.638	161.501	5.0016
0.300	75.348	33.550	41.798	0.109458	313.271	187.963	5.1740
0.325	82.784	36.545	46.239	0.117098	332.506	216.129	5.3389
0.350	90.367	39.559	50.808	0.124486	351.364	245.955	5.4971
0.375	98.090	42.590	55.501	0.131625	369.865	277.399	5.6495
0.400	105.946	45.635	60.311	0.138516	388.025	310.420	5.7964
0.425	113.927	48.695	65.233	0.145164	405.858	344.979	5.9385
0.450	122.027	51.766	70.262	0.151574	423.377	381.039	6.0760
0.475	130.239	54.847	75.392	0.157751	440.593	418.563	6.2094
0.500	138.555	57.937	80.618	0.163702	457.516	457.516	6.3388
0.525	146.970	61.034	85.936	0.169433	474.158	497.866	6.4646
0.550	155.478	64.139	91.340	0.174951	490.527	539.580	6.5870
0.575	164.073	67.248	96.825	0.180264	506.633	582.629	6.7062
0.600	172.750	70.363	102.387	0.185379	522.486	626.983	6.8224
0.625	181.504	73.481	108.022	0.190303	538.093	672.617	6.9358
0.650	190.329	76.603	113.726	0.195045	553.464	719.503	7.0464
0.675	199.222	79.728	119.494	0.199610	568.606	767.618	7.1545
0.700	208.178	82.854	125.324	0.204007	583.528	816.939	7.2601
0.725	217.193	85.982	131.211	0.208242	598.237	867.444	7.3635
0.750	226.264	89.111	137.152	0.212323	612.742	919.112	7.4646
0.775	235.386	92.241	143.145	0.216255	627.048	971.924	7.5636

Table I (cont.)

Nuclear Properties Along Green's Valley of Stability

x	A	Z	N	I	$E_S^{(o)}$ (MeV)	$E_C^{(o)}$ (MeV)	R (fm)
0.800	244.558	95.372	149.186	0.220046	641.163	1025.861	7.6606
0.825	253.776	98.503	155.273	0.223701	655.094	1080.905	7.7556
0.850	263.036	101.634	161.402	0.227227	668.848	1137.041	7.8488
0.875	272.337	104.764	167.573	0.230629	682.430	1194.252	7.9403
0.900	281.676	107.894	173.782	0.233913	695.846	1252.523	8.0300
0.925	291.050	111.024	180.027	0.237084	709.103	1311.841	8.1181
0.950	300.459	114.152	186.306	0.240147	722.206	1372.191	8.2047
0.975	309.898	117.280	192.618	0.243106	735.160	1433.561	8.2897
1.000	319.368	120.407	198.961	0.245967	747.970	1495.939	8.3733
1.025	328.866	123.533	205.333	0.248733	760.641	1559.314	8.4555
1.050	338.390	126.658	211.732	0.251409	773.178	1623.673	8.5364
1.075	347.939	129.781	218.157	0.253998	785.585	1689.007	8.6159
1.100	357.511	132.904	224.607	0.256505	797.866	1755.305	8.6942
1.125	367.106	136.025	231.081	0.258933	810.026	1822.559	8.7713
1.150	376.722	139.145	237.577	0.261285	822.069	1890.758	8.8472
1.175	386.358	142.264	244.094	0.263564	833.997	1959.894	8.9220
1.200	396.012	145.381	250.631	0.265775	845.816	2029.958	8.9957
1.225	405.685	148.497	257.187	0.267918	857.527	2100.942	9.0684
1.250	415.374	151.612	263.762	0.269998	869.135	2172.838	9.1400
1.275	425.079	154.725	270.354	0.272016	880.643	2245.640	9.2106
1.300	434.799	157.837	276.962	0.273976	892.053	2319.339	9.2803
1.325	444.534	160.948	283.586	0.275879	903.369	2393.928	9.3491
1.350	454.283	164.058	290.225	0.277729	914.593	2469.401	9.4169
1.375	464.044	167.166	296.878	0.279526	925.728	2545.752	9.4839
1.400	473.818	170.273	303.545	0.281274	936.776	2622.974	9.5500
1.425	483.604	173.378	310.225	0.282973	947.741	2701.061	9.6153
1.450	493.401	176.482	316.918	0.284627	958.623	2780.006	9.6798
1.475	503.208	179.586	323.622	0.286236	969.426	2859.805	9.7435
1.500	513.026	182.688	330.338	0.287802	980.151	2940.453	9.8065

Table II

SADDLE-POINT PROPERTIES

X	BARRIER	SURFACE	COULOMB	RHO	LAMBDA	INPERP	INPAR	QUADRUPOLE	R1	R2	SCALE	STIFF2
	Z1	Z2	Z CUT	FMASS	ZCM1	ZCM2	COMPACT	OPENING	ANGLE	STIFF1		
ASYMMETRY DELTA 0.												
.300	.16890	.27291	-.17336	1.4001	.3061	3.5013	.5977	2.3229	.7838	.7838	1.5675	
	.5439	1.6509	1.0974	.5000	.0307	2.1640	2.1333	.0285	30.9119	.0629	-3.7160	
.350	.15135	.27550	-.17734	1.4450	.3362	3.6290	.5893	2.4318	.7809	.7809	1.5618	
	.5184	1.7386	1.1285	.5000	.0398	2.2171	2.1772	.0408	29.7567	.0655	-2.7152	
.400	.13344	.27811	-.18083	1.4907	.3668	3.7477	.5797	2.5344	.7775	.7775	1.5550	
	.4923	1.8257	1.1590	.5000	.0509	2.2671	2.2161	.0561	28.5128	.0628	-2.0186	
.450	.11520	.28068	-.18386	1.5383	.3988	3.8568	.5685	2.6306	.7733	.7733	1.5465	
	.4649	1.9142	1.1895	.5000	.0646	2.3144	2.2498	.0752	27.1683	.0575	-1.4943	
.500	.09669	.28304	-.18636	1.5892	.4336	3.9524	.5551	2.7178	.7679	.7679	1.5358	
	.4349	2.0058	1.2204	.5000	.0820	2.3588	2.2768	.0999	25.7392	.0506	-1.0749	
.550	.07796	.28472	-.18797	1.6445	.4732	4.0229	.5388	2.7873	.7609	.7609	1.5217	
	.4008	2.1016	1.2512	.5000	.1049	2.3975	2.2927	.1338	24.2935	.0429	-.7224	
.600	.05916	.28413	-.18747	1.7035	.5221	4.0322	.5183	2.8111	.7508	.7508	1.5016	
	.3588	2.1992	1.2790	.5000	.1369	2.4211	2.2842	.1858	23.1813	.0348	-.4154	
.625	.04983	.28131	-.18518	1.7316	.5533	3.9798	.5061	2.7790	.7437	.7437	1.4875	
	.3322	2.2435	1.2879	.5000	.1586	2.4171	2.2585	.2265	23.2287	.0308	-.2780	
.650	.04070	.27369	-.17922	1.7508	.5942	3.8341	.4926	2.6732	.7342	.7342	1.4685	
	.2980	2.2730	1.2855	.5000	.1862	2.3848	2.1987	.2895	24.8625	.0273	-.1557	
.675	.03206	.25395	-.16437	1.7362	.6548	3.4912	.4817	2.4076	.7211	.7211	1.4422	
	.2489	2.2549	1.2519	.5000	.2191	2.2847	2.0656	.4007	30.8392	.0254	-.0695	
.700	.02449	.21649	-.13715	1.6510	.7409	2.9481	.4862	1.9695	.7073	.7073	1.4147	
	.1832	2.1524	1.1678	.5000	.2421	2.0936	1.8515	.5723	38.3400	.0243	-.0374	
.725	.01835	.17643	-.10902	1.5273	.8333	2.4735	.5083	1.5721	.6994	.6994	1.3987	
	.1166	2.0197	1.0682	.5000	.2422	1.8941	1.6519	.7454	41.1854	.0212	-.0287	
.750	.01350	.14223	-.08582	1.3996	.9233	2.1303	.5387	1.2733	.6970	.6970	1.3940	
	.0535	1.8976	.9755	.5000	.2276	1.7235	1.4959	.8926	42.6066	.0178	-.0235	
.775	.00969	.11355	-.06701	1.2734	1.0120	1.8767	.5730	1.0430	.6989	.6989	1.3977	
	-.0084	1.7883	.8900	.5000	.2044	1.5755	1.3712	1.0153	43.9268	.0146	-.0191	
.800	.00674	.08927	-.05158	1.1482	1.1012	1.6818	.6098	.8576	.7044	.7044	1.4087	
	-.0713	1.6888	.8088	.5000	.1750	1.4425	1.2675	1.1162	45.3888	.0118	-.0154	
.825	.00449	.06856	-.03883	1.0227	1.1920	1.5273	.6487	.7028	.7134	.7134	1.4269	
	-.1370	1.5962	.7296	.5000	.1403	1.3189	1.1786	1.1964	47.0682	.0092	-.0122	
.850	.00282	.05089	-.02878	.8954	1.2856	1.4022	.6898	.5699	.7264	.7264	1.4529	
	-.2075	1.5084	.6505	.5000	.1003	1.2007	1.1004	1.2558	49.0422	.0069	-.0094	
.875	.00163	.03594	-.01960	.7652	1.3832	1.2993	.7331	.4530	.7440	.7440	1.4879	
	-.2851	1.4237	.5693	.5000	.0542	1.0844	1.0303	1.2932	51.4378	.0048	-.0071	
.900	.00083	.02352	-.01260	.6310	1.4865	1.2141	.7791	.3480	.7672	.7672	1.5343	
	-.3732	1.3414	.4841	.5000	.0009	.9672	.9663	1.3070	54.4551	.0029	-.0052	

X	BARRIER	SURFACE	COULOMB	RHO	LAMBDA	INPERP	INPAR	QUADRUPOLE	R1	R2	SCALE	
	Z1	Z2	Z CUT	FMASS	ZCM1	ZCM2	COMPACT	OPENING	ANGLE	STIFF1	STIFF2	
ASYMMETRY DELTA .025												
.300	.16869	.27207	-.17230	1.3991	.3054	3.4809	.5997	2.3050	.8029	.7638	1.5667	
	.5581	1.6618	1.1234	.5373	.0310	2.1619	2.1309	.0283	30.9396	.0627	-3.7323	
.350	.15125	.27465	-.17628	1.4440	.3355	3.6080	.5914	2.4133	.8000	.7610	1.5610	
	.5322	1.7489	1.1552	.5372	.0401	2.2150	2.1749	.0405	29.7838	.0653	-2.7287	
.400	.13345	.27727	-.17978	1.4896	.3660	3.7265	.5818	2.5158	.7965	.7577	1.5542	
	.5057	1.8355	1.1865	.5370	.0511	2.2651	2.2140	.0557	28.5366	.0627	-2.0310	
.450	.11531	.27987	-.18284	1.5373	.3980	3.8360	.5706	2.6123	.7922	.7536	1.5458	
	.4779	1.9236	1.2179	.5368	.0647	2.3127	2.2480	.0746	27.1831	.0574	-1.5064	
.500	.09690	.28230	-.18540	1.5883	.4327	3.9331	.5572	2.7007	.7868	.7484	1.5353	
	.4476	2.0150	1.2497	.5366	.0819	2.3576	2.2756	.0990	25.7374	.0506	-1.0872	
.550	.07826	.28411	-.18714	1.6440	.4721	4.0069	.5410	2.7728	.7797	.7416	1.5213	
	.4131	2.1109	1.2817	.5362	.1046	2.3973	2.2927	.1323	24.2576	.0429	-.7348	
.600	.05953	.28386	-.18694	1.7041	.5206	4.0242	.5206	2.8029	.7695	.7319	1.5014	
	.3709	2.2096	1.3112	.5357	.1363	2.4231	2.2868	.1831	23.0569	.0347	-.4274	
.625	.05022	.28142	-.18496	1.7334	.5514	3.9800	.5083	2.7774	.7624	.7252	1.4875	
	.3444	2.2555	1.3214	.5352	.1577	2.4214	2.2638	.2225	22.9921	.0307	-.2889	
.650	.04109	.27456	-.17960	1.7551	.5914	3.8485	.4946	2.6831	.7528	.7161	1.4688	
	.3106	2.2883	1.3212	.5346	.1849	2.3935	2.2086	.2830	24.3622	.0271	-.1643	
.675	.03240	.25620	-.16577	1.7458	.6506	3.5257	.4828	2.4344	.7394	.7033	1.4426	
	.2623	2.2769	1.2908	.5336	.2182	2.3004	2.0822	.3903	29.9788	.0250	-.0731	
.700	.02475	.21912	-.13884	1.6646	.7370	2.9809	.4857	1.9962	.7247	.6893	1.4140	
	.1966	2.1785	1.2063	.5322	.2431	2.1102	1.8671	.5625	37.9482	.0240	-.0376	
.725	.01854	.17834	-.11021	1.5403	.8307	2.4929	.5072	1.5885	.7159	.6810	1.3969	
	.1296	2.0447	1.1027	.5310	.2442	1.9064	1.6621	.7398	40.9749	.0210	-.0287	
.750	.01364	.14360	-.08664	1.4116	.9218	2.1422	.5375	1.2838	.7131	.6783	1.3914	
	.0667	1.9221	1.0066	.5300	.2298	1.7326	1.5028	.8902	42.3713	.0176	-.0235	
.775	.00980	.11457	-.06760	1.2850	1.0114	1.8846	.5718	1.0502	.7147	.6798	1.3945	
	.0056	1.8134	.9184	.5291	.2066	1.5828	1.3762	1.0153	43.6413	.0145	-.0192	
.800	.00682	.09006	-.05202	1.1597	1.1015	1.6874	.6087	.8630	.7200	.6848	1.4048	
	-.0561	1.7155	.8349	.5283	.1771	1.4485	1.2714	1.1184	45.0411	.0116	-.0154	
.825	.00455	.06919	-.03917	1.0344	1.1934	1.5315	.6476	.7071	.7288	.6933	1.4221	
	-.1203	1.6257	.7539	.5275	.1423	1.3240	1.1817	1.2008	46.6367	.0090	-.0122	
.850	.00286	.05140	-.02855	.9077	1.2885	1.4055	.6886	.5735	.7416	.7054	1.4469	
	-.1888	1.5421	.6766	.5285	.1041	1.2072	1.1031	1.2626	48.4844	.0067	-.0094	
.875	.00166	.03636	-.01983	.7788	1.3884	1.3020	.7319	.4561	.7587	.7216	1.4803	
	-.2637	1.4641	.6002	.5309	.0614	1.0942	1.0327	1.3033	50.6663	.0046	-.0071	
.900	.00085	.02387	-.01279	.6469	1.4963	1.2164	.7777	.3510	.7809	.7428	1.5237	
	-.3486	1.3931	.5222	.5348	.0134	.9821	.9687	1.3218	53.2640	.0028	-.0051	

X	BARRIER	SURFACE	COULOMB	RHO	LAMBDA	INPERP	INPAR	QUADRUPOLE	R1	R2	SCALE
	Z1	Z2	Z CUT	FMASS	ZCM1	ZCM2	COMPACT	OPENING	ANGLE	STIFF1	STIFF2
ASYMMETRY DELTA .050											
.300	.16806	.26954	-.16914	1.3960	.3034	3.4208	.6058	2.2520	.8212	.7430	1.5641
	.5728	1.6667	1.1463	.5742	.0308	2.1545	2.1237	.0277	31.0203	.0620	-3.7805
.350	.15094	.27212	-.17312	1.4407	.3334	3.5462	.5975	2.3589	.8183	.7403	1.5586
	.5466	1.7530	1.1789	.5740	.0398	2.2076	2.1679	.0397	29.8656	.0649	-2.7691
.400	.13345	.27477	-.17665	1.4863	.3637	3.6639	.5880	2.4608	.8148	.7372	1.5519
	.5199	1.8389	1.2109	.5737	.0506	2.2580	2.2074	.0544	28.6044	.0625	-2.0678
.450	.11562	.27745	-.17981	1.5340	.3955	3.7744	.5769	2.5581	.8105	.7333	1.5438
	.4918	1.9267	1.2433	.5734	.0639	2.3064	2.2425	.0728	27.2313	.0572	-1.5424
.500	.09750	.28004	-.18255	1.5855	.4299	3.8753	.5636	2.6493	.8051	.7284	1.5335
	.4613	2.0183	1.2764	.5729	.0808	2.3527	2.2719	.0963	25.7399	.0504	-1.1236
.550	.07913	.28224	-.18464	1.6422	.4688	3.9583	.5475	2.7287	.7980	.7220	1.5199
	.4268	2.1155	1.3104	.5722	.1029	2.3952	2.2923	.1280	24.1668	.0427	-.7720
.600	.06062	.28291	-.18524	1.7051	.5162	3.9972	.5272	2.7760	.7879	.7129	1.5008
	.3851	2.2180	1.3435	.5712	.1336	2.4273	2.2937	.1754	22.7307	.0345	-.4640
.625	.05138	.28149	-.18409	1.7377	.5457	3.9750	.5149	2.7681	.7810	.7066	1.4876
	.3593	2.2684	1.3571	.5704	.1542	2.4322	2.2779	.2112	22.3723	.0304	-.3231
.650	.04225	.27670	-.18034	1.7661	.5834	3.8832	.5008	2.7059	.7717	.6982	1.4699
	.3270	2.3106	1.3629	.5693	.1807	2.4165	2.2358	.2648	23.0393	.0265	-.1924
.675	.03345	.26246	-.16964	1.7724	.6382	3.6249	.4866	2.5106	.7584	.6861	1.4445
	.2817	2.3192	1.3441	.5674	.2148	2.3459	2.1311	.3597	27.3341	.0238	-.0870
.700	.02554	.22752	-.14427	1.7063	.7241	3.0891	.4843	2.0838	.7417	.6710	1.4127
	.2156	2.2364	1.2656	.5646	.2461	2.1641	1.9180	.5306	36.5610	.0232	-.0386
.725	.01910	.18441	-.11400	1.5803	.8225	2.5559	.5039	1.6416	.7306	.6611	1.3917
	.1455	2.0978	1.1546	.5619	.2516	1.9463	1.6947	.7214	40.3657	.0205	-.0284
.750	.01405	.14784	-.08919	1.4484	.9171	2.1796	.5339	1.3166	.7265	.6573	1.3838
	.0812	1.9708	1.0523	.5597	.2386	1.7629	1.5243	.8821	41.6955	.0171	-.0235
.775	.01010	.11770	-.06942	1.3201	1.0095	1.9091	.5682	1.0727	.7271	.6578	1.3849
	.0197	1.8609	.9598	.5579	.2161	1.6077	1.3916	1.0151	42.8126	.0140	-.0192
.800	.00704	.09247	-.05339	1.1943	1.1022	1.7046	.6052	.8796	.7314	.6618	1.3932
	-.0420	1.7642	.8735	.5562	.1873	1.4704	1.2831	1.1249	44.0305	.0112	-.0155
.825	.00471	.07110	-.04024	1.0695	1.1972	1.5444	.6441	.7202	.7392	.6688	1.4081
	-.1059	1.6777	.7906	.5546	.1533	1.3444	1.1911	1.2140	45.3874	.0086	-.0122
.850	.00298	.05296	-.02940	.9448	1.2966	1.4156	.6850	.5845	.7505	.6790	1.4295
	-.1742	1.6004	.7131	.5549	.1167	1.2277	1.1111	1.2834	46.8841	.0063	-.0095
.875	.00174	.03766	-.02052	.8195	1.4032	1.3104	.7280	.4659	.7654	.6925	1.4579
	-.2495	1.5331	.6418	.5587	.0788	1.1188	1.0400	1.3338	48.4905	.0042	-.0071
.900	.00090	.02499	-.01338	.6951	1.5237	1.2239	.7732	.3605	.7835	.7089	1.4924
	-.3371	1.4819	.5724	.5645	.0383	1.0142	.9758	1.3674	50.0091	.0024	-.0050

X	BARRIER Z1	SURFACE Z2	COULOMB Z CUT	RHO FMASS	LAMBDA ZCM1	INPERP ZCM2	INPAR COMPACT	QUADRUPOLE OPENING	R1 ANGLE	R2 ANGLE	SCALE STIFF1	STIFF2
ASYMMETRY DELTA .075												
.300	.16698	.26540	-.16402	1.3909	.3001	3.3241	.6156	2.1668	.8384	.7215	1.5599	
	.5879	1.6658	1.1662	.6104	.0303	2.1420	2.1117	.0267	31.1571	.0608	-3.8622	
.350	.15038	.26797	-.16799	1.4353	.3298	3.4464	.6075	2.2711	.8356	.7190	1.5546	
	.5616	1.7509	1.1993	.6101	.0390	2.1952	2.1562	.0383	30.0039	.0642	-2.8364	
.400	.13340	.27065	-.17156	1.4807	.3599	3.5626	.5981	2.3716	.8321	.7160	1.5482	
	.5347	1.8360	1.2321	.6097	.0495	2.2459	2.1964	.0524	28.7288	.0620	-2.1289	
.450	.11608	.27342	-.17483	1.5285	.3913	3.6740	.5871	2.4695	.8279	.7124	1.5403	
	.5066	1.9234	1.2655	.6092	.0624	2.2953	2.2329	.0700	27.3236	.0569	-1.6018	
.500	.09844	.27626	-.17782	1.5805	.4253	3.7797	.5741	2.5645	.8226	.7078	1.5305	
	.4761	2.0154	1.3002	.6086	.0786	2.3436	2.2650	.0921	25.7677	.0501	-1.1837	
.550	.08052	.27898	-.18041	1.6387	.4635	3.8751	.5582	2.6535	.8157	.7019	1.5176	
	.4418	2.1144	1.3367	.6077	.0998	2.3902	2.2904	.1215	24.0654	.0424	-.8340	
.600	.06239	.28091	-.18210	1.7053	.5091	3.9436	.5381	2.7244	.8060	.6936	1.4996	
	.4010	2.2222	1.3746	.6063	.1290	2.4313	2.3023	.1638	22.3219	.0341	-.5259	
.625	.05328	.28086	-.18207	1.7420	.5370	3.9515	.5259	2.7405	.7995	.6879	1.4874	
	.3764	2.2787	1.3927	.6053	.1486	2.4452	2.2967	.1945	21.5910	.0300	-.3839	
.650	.04421	.27879	-.18045	1.7789	.5711	3.9146	.5116	2.7224	.7909	.6805	1.4714	
	.3465	2.3330	1.4069	.6039	.1735	2.4465	2.2730	.2384	21.3719	.0259	-.2475	
.675	.03530	.27081	-.17445	1.8068	.6185	3.7633	.4953	2.6144	.7785	.6699	1.4484	
	.3063	2.3707	1.4066	.6016	.2069	2.4119	2.2050	.3125	23.3088	.0223	-.1226	
.700	.02699	.24327	-.15448	1.7779	.6986	3.3069	.4838	2.2585	.7599	.6538	1.4137	
	.2429	2.3301	1.3509	.5976	.2476	2.2664	2.0188	.4668	32.8945	.0213	-.0433	
.725	.02010	.19602	-.12132	1.6522	.8064	2.6820	.4979	1.7472	.7440	.6402	1.3842	
	.1654	2.1843	1.2292	.5928	.2640	2.0221	1.7581	.6839	39.4055	.0198	-.0277	
.750	.01475	.15556	-.09387	1.5127	.9082	2.2497	.5275	1.3778	.7372	.6343	1.3716	
	.0970	2.0459	1.1152	.5892	.2544	1.8179	1.5635	.8660	40.6686	.0164	-.0233	
.775	.01061	.12324	-.07267	1.3803	1.0056	1.9533	.5620	1.1130	.7360	.6333	1.3693	
	.0334	1.9311	1.0159	.5862	.2334	1.6522	1.4187	1.0134	41.5095	.0133	-.0193	
.800	.00741	.09667	-.05579	1.2531	1.1028	1.7352	.5990	.9089	.7387	.6356	1.3743	
	-.0295	1.8339	.9257	.5834	.2059	1.5094	1.3035	1.1353	42.4283	.0105	-.0156	
.825	.00497	.07441	-.04208	1.1291	1.2029	1.5670	.6380	.7432	.7446	.6407	1.3853	
	-.0945	1.7506	.8407	.5808	.1736	1.3809	1.2073	1.2361	43.4191	.0079	-.0124	
.850	.00316	.05565	-.03088	1.0073	1.3089	1.4334	.6787	.6037	.7533	.6482	1.4015	
	-.1643	1.6803	.7588	.5779	.1375	1.2618	1.1243	1.3186	44.4081	.0057	-.0095	
.875	.00185	.03990	-.02174	.8882	1.4258	1.3252	.7212	.4832	.7643	.6576	1.4219	
	-.2427	1.6258	.6915	.5813	.1049	1.1568	1.0519	1.3860	45.2525	.0037	-.0070	
.900	.00096	.02693	-.01443	.7764	1.5646	1.2370	.7655	.3772	.7756	.6674	1.4429	
	-.3376	1.5973	.6298	.5860	.0733	1.0606	.9872	1.4465	45.6210	.0019	-.0048	

X	BARRIER	SURFACE	COULOMB	RHO	LAMBDA	INPERP	INPAR	QUADRUPOLE	R1	R2	SCALE
	Z1	Z2	Z CUT	FMASS	ZCM1	ZCM2	COMPACT	OPENING	ANGLE	STIFF1	STIFF2
ASYMMETRY DELTA .100											
.300	.16544	.25972	-.15713	1.3839	.2955	3.1959	.6290	2.0535	.8547	.6993	1.5540
	.6035	1.6594	1.1828	.6455	.0294	2.1246	2.0953	.0254	31.3541	.0590	-3.9805
.350	.14953	.26226	-.16105	1.4278	.3248	3.3133	.6210	2.1538	.8519	.6970	1.5490
	.5771	1.7429	1.2164	.6452	.0377	2.1776	2.1398	.0364	30.2014	.0632	-2.9310
.400	.13324	.26496	-.16465	1.4728	.3545	3.4268	.6119	2.2519	.8486	.6943	1.5429
	.5503	1.8268	1.2498	.6448	.0478	2.2287	2.1809	.0498	28.9133	.0614	-2.2136
.450	.11660	.26784	-.16804	1.5206	.3855	3.5381	.6011	2.3496	.8445	.6910	1.5355
	.5223	1.9136	1.2842	.6442	.0601	2.2791	2.2190	.0663	27.4749	.0565	-1.6835
.500	.09964	.27093	-.17129	1.5730	.4189	3.6480	.5883	2.4478	.8394	.6868	1.5262
	.4920	2.0058	1.3204	.6434	.0755	2.3296	2.2541	.0867	25.8498	.0498	-1.2664
.550	.08235	.27420	-.17441	1.6325	.4561	3.7558	.5728	2.5464	.8328	.6814	1.5142
	.4582	2.1065	1.3595	.6423	.0956	2.3808	2.2853	.1132	24.0115	.0421	-9.200
.600	.06476	.27743	-.17722	1.7027	.4998	3.8545	.5532	2.6410	.8237	.6740	1.4977
	.4185	2.2196	1.4026	.6408	.1229	2.4317	2.3088	.1499	21.9620	.0339	-6.166
.625	.05587	.27873	-.17829	1.7432	.5257	3.8928	.5413	2.6812	.8177	.6690	1.4867
	.3952	2.2817	1.4254	.6397	.1409	2.4551	2.3142	.1750	20.9012	.0296	-4.744
.650	.04695	.27925	-.17869	1.7877	.5562	3.9107	.5273	2.7067	.8100	.6627	1.4727
	.3680	2.3472	1.4481	.6382	.1636	2.4735	2.3099	.2086	19.9591	.0254	-3.354
.675	.03803	.27734	-.17726	1.8344	.5951	3.8751	.5105	2.6917	.7994	.6541	1.4535
	.3339	2.4116	1.4664	.6360	.1937	2.4765	2.2828	.2599	19.6737	.0213	-1.983
.700	.02933	.26535	-.16859	1.8644	.6566	3.6518	.4907	2.5288	.7824	.6402	1.4226
	.2824	2.4461	1.4587	.6320	.2376	2.4179	2.1803	.3634	23.8373	.0182	-0.729
.725	.02164	.21748	-.13506	1.7691	.7748	2.9362	.4889	1.9578	.7578	.6200	1.3778
	.1941	2.3212	1.3406	.6243	.2796	2.1594	1.8798	.6077	37.9665	.0187	-0.257
.750	.01577	.16824	-.10165	1.6110	.8926	2.3706	.5173	1.4826	.7456	.6101	1.3557
	.1149	2.1534	1.2013	.6183	.2778	1.9062	1.6284	.8353	39.5377	.0156	-0.225
.775	.01132	.13179	-.07772	1.4692	.9986	2.0238	.5524	1.1771	.7416	.6068	1.3484
	.0468	2.0260	1.0896	.6138	.2592	1.7197	1.4605	1.0081	39.8840	.0124	-0.192
.800	.00791	.10295	-.05940	1.3383	1.1025	1.7821	.5899	.9537	.7419	.6070	1.3489
	.0188	1.9248	.9929	.6098	.2335	1.5670	1.3336	1.1487	40.3744	.0096	-0.157
.825	.00531	.07927	-.04482	1.2143	1.2095	1.6010	.6290	.7775	.7451	.6096	1.3547
	.0861	1.8427	.9048	.6058	.2035	1.4341	1.2306	1.2670	40.9176	.0072	-0.125
.850	.00338	.05954	-.03304	1.0959	1.3240	1.4596	.6696	.6319	.7504	.6139	1.3643
	.1588	1.7783	.8223	.6017	.1707	1.3142	1.1434	1.3688	41.3716	.0050	-0.095
.875	.00197	.04309	-.02349	.9841	1.4531	1.3464	.7117	.5078	.7564	.6188	1.3752
	.2417	1.7348	.7465	.5979	.1380	1.2057	1.0677	1.4605	41.6058	.0031	-0.069
.900	.00100	.02946	-.01581	.8832	1.6120	1.2542	.7557	.3988	.7604	.6221	1.3825
	.3447	1.7223	.6888	.5998	.1136	1.1145	1.0009	1.5560	41.9084	.0016	-0.044

X	BARRIER Z1	SURFACE Z2	COULOMB Z CUT	RHO	LAMBDA FMASS	INPERP ZCM1	INPAR ZCM2	QUADRUPOLE COMPACT	R1 OPENING	R2 ANGLE	SCALE STIFF1	STIFF2
ASYMMETRY DELTA .125												
.300	.16340	.25262	-.14870	1.3750	.2897	3.0419	.6455	1.9171	.8699	.6766	1.5466	
	.6196	1.6475	1.1961	.6794	.0281	2.1024	2.0743	.0238	31.5958	.0566	-4.1344	
.350	.14833	.25512	-.15255	1.4182	.3186	3.1532	.6377	2.0124	.8673	.6745	1.5418	
	.5933	1.7292	1.2299	.6791	.0361	2.1550	2.1189	.0341	30.4550	.0619	-3.0531	
.400	.13289	.25781	-.15614	1.4626	.3477	3.2622	.6288	2.1067	.8641	.6721	1.5362	
	.5666	1.8115	1.2639	.6786	.0456	2.2063	2.1607	.0467	29.1646	.0606	-2.3215	
.450	.11711	.26076	-.15962	1.5101	.3781	3.3716	.6184	2.2026	.8602	.6691	1.5293	
	.5388	1.8971	1.2990	.6779	.0572	2.2575	2.2003	.0619	27.6996	.0560	-1.7865	
.500	.10097	.26405	-.16308	1.5626	.4108	3.4837	.6060	2.3022	.8554	.6653	1.5207	
	.5089	1.9890	1.3366	.6771	.0717	2.3101	2.2385	.0805	26.0156	.0495	-1.3701	
.550	.08448	.26780	-.16665	1.6229	.4469	3.6007	.5909	2.4078	.8492	.6605	1.5097	
	.4756	2.0907	1.3781	.6759	.0903	2.3655	2.2752	.1040	24.0604	.0419	-1.0285	
.600	.06763	.27212	-.17041	1.6956	.4886	3.7236	.5721	2.5212	.8408	.6540	1.4948	
	.4373	2.2075	1.4257	.6743	.1155	2.4252	2.3098	.1349	21.7721	.0337	-0.7330	
.625	.05906	.27449	-.17234	1.7388	.5126	3.7862	.5607	2.5804	.8354	.6498	1.4852	
	.4153	2.2738	1.4526	.6732	.1317	2.4568	2.3250	.1549	20.4834	.0295	-0.5953	
.650	.05040	.27690	-.17423	1.7882	.5398	3.8462	.5474	2.6390	.8287	.6445	1.4732	
	.3905	2.3469	1.4818	.6719	.1518	2.4889	2.3371	.1798	19.1061	.0253	-0.4603	
.675	.04165	.27901	-.17582	1.8453	.5719	3.8949	.5317	2.6906	.8200	.6378	1.4578	
	.3614	2.4275	1.5132	.6700	.1775	2.5192	2.3417	.2133	17.6994	.0212	-0.3246	
.700	.03284	.27929	-.17604	1.9109	.6136	3.8990	.5119	2.7097	.8077	.6282	1.4359	
	.3244	2.5134	1.5434	.6672	.2131	2.5375	2.3244	.2659	16.6990	.0172	-0.1826	
.725	.02418	.26407	-.16544	1.9564	.6936	3.6107	.4856	2.5002	.7837	.6095	1.3932	
	.2579	2.5568	1.5332	.6606	.2742	2.4581	2.1839	.4070	24.6001	.0143	-0.0375	
.750	.01721	.19035	-.11542	1.7614	.8630	2.5990	.5014	1.6781	.7530	.5857	1.3386	
	.1392	2.3137	1.3263	.6477	.3095	2.0535	1.7440	.7707	39.2471	.0149	-0.0195	
.775	.01225	.14463	-.08541	1.5937	.9862	2.1348	.5386	1.2770	.7442	.5788	1.3230	
	.0610	2.1513	1.1860	.6407	.2942	1.8175	1.5232	.9936	38.2846	.0115	-0.0187	
.800	.00852	.11179	-.06454	1.4533	1.1000	1.8503	.5774	1.0184	.7413	.5765	1.3178	
	.0092	2.0378	1.0773	.6351	.2704	1.6459	1.3755	1.1635	38.1128	.0087	-0.0157	
.825	.00571	.08586	-.04857	1.3267	1.2156	1.6482	.6171	.8248	.7412	.5765	1.3178	
	.0800	1.9524	.9834	.6297	.2427	1.5044	1.2617	1.3065	38.1695	.0064	-0.0126	
.850	.00361	.06465	-.03590	1.2100	1.3399	1.4946	.6580	.6692	.7426	.5776	1.3201	
	.1562	1.8899	.8985	.6240	.2133	1.3812	1.1679	1.4337	38.2249	.0044	-0.0095	
.875	.00208	.04702	-.02568	1.1024	1.4819	1.3730	.7004	.5381	.7437	.5785	1.3222	
	.2436	1.8511	.8199	.6173	.1835	1.2707	1.0873	1.5555	38.4244	.0027	-0.0067	
.900	.00102	.03188	-.01715	.9951	1.6578	1.2708	.7468	.4192	.7443	.5789	1.3232	
	.3521	1.8350	.7415	.6092	.1512	1.1647	1.0135	1.6808	40.9106	.0014	-0.0038	

X	BARRIER	SURFACE	COULOMB	RHO	LAMBDA	INPERP	INPAR	QUADRUPOLE	R1	R2	SCALE
	Z1	Z2	Z CUT	FMASS	ZCM1	ZCM2	COMPACT	OPENING	ANGLE	STIFF1	STIFF2
ASYMMETRY	DELTA	.150									
.300	.16082	.24425	-.13904	1.3643	.2827	2.8695	.6644	1.7640	.8841	.6535	1.5376
	.6360	1.6309	1.2062	.7117	.0267	2.0758	2.0492	.0219	31.8912	.0534	-4.3320
.350	.14673	.24667	-.14278	1.4066	.3110	2.9731	.6570	1.8528	.8816	.6516	1.5332
	.6100	1.7102	1.2401	.7113	.0341	2.1278	2.0937	.0316	30.7714	.0601	-3.2054
.400	.13227	.24932	-.14632	1.4502	.3396	3.0760	.6484	1.9421	.8786	.6494	1.5280
	.5836	1.7904	1.2742	.7109	.0430	2.1788	2.1358	.0432	29.4933	.0596	-2.4532
.450	.11746	.25229	-.14981	1.4970	.3693	3.1812	.6384	2.0342	.8750	.6467	1.5217
	.5561	1.8743	1.3098	.7102	.0538	2.2305	2.1767	.0571	28.0131	.0554	-1.9095
.500	.10230	.25571	-.15340	1.5490	.4010	3.2922	.6265	2.1325	.8705	.6434	1.5139
	.5267	1.9649	1.3484	.7094	.0671	2.2846	2.2174	.0738	26.2891	.0492	-1.4926
.550	.08677	.25978	-.15728	1.6093	.4359	3.4132	.6121	2.2409	.8648	.6392	1.5039
	.4943	2.0662	1.3917	.7082	.0843	2.3432	2.2589	.0943	24.2535	.0417	-1.1565
.600	.07083	.26483	-.16166	1.6830	.4756	3.5506	.5942	2.3651	.8572	.6336	1.4907
	.4573	2.1844	1.4426	.7067	.1071	2.4095	2.3024	.1201	21.8134	.0337	-.8724
.625	.06269	.26788	-.16415	1.7273	.4979	3.6280	.5835	2.4356	.8523	.6300	1.4823
	.4365	2.2527	1.4723	.7057	.1216	2.4469	2.3253	.1359	20.3978	.0296	-.7430
.650	.05441	.27140	-.16692	1.7787	.5225	3.7131	.5712	2.5135	.8466	.6257	1.4723
	.4136	2.3293	1.5058	.7044	.1391	2.4881	2.3490	.1542	18.8273	.0255	-.6183
.675	.04599	.27551	-.17001	1.8394	.5501	3.8070	.5569	2.6001	.8395	.6205	1.4599
	.3880	2.4165	1.5441	.7029	.1607	2.5340	2.3733	.1763	17.0679	.0216	-.4952
.700	.03740	.28027	-.17347	1.9131	.5817	3.9092	.5399	2.6954	.8304	.6138	1.4442
	.3587	2.5175	1.5887	.7010	.1882	2.5850	2.3967	.2043	15.0730	.0178	-.3691
.725	.02864	.28543	-.17710	2.0049	.6202	4.0102	.5189	2.7931	.8181	.6047	1.4229
	.3234	2.6356	1.6403	.6983	.2254	2.6389	2.4135	.2440	12.7603	.0143	-.2314
.750	.01973	.28596	-.17749	2.1219	.6839	3.9931	.4875	2.8044	.7955	.5880	1.3836
	.2676	2.7660	1.6881	.6925	.2903	2.6596	2.3693	.3368	10.9989	.0104	-.0520
.775	.01346	.16519	-.09789	1.7715	.9626	2.3251	.5183	1.4455	.7444	.5502	1.2946
	.0790	2.3239	1.3187	.6675	.3409	1.9652	1.6242	.9552	37.9099	.0110	-.0163
.800	.00927	.12410	-.07177	1.6041	1.0931	1.9491	.5607	1.1108	.7372	.5449	1.2822
	.0002	2.1763	1.1826	.6595	.3174	1.7507	1.4333	1.1758	36.0748	.0080	-.0153
.825	.00616	.09441	-.05349	1.4678	1.2198	1.7111	.6023	.8871	.7337	.5423	1.2760
	-.0750	2.0783	1.0769	.6524	.2909	1.5923	1.3013	1.3530	35.5536	.0057	-.0125
.850	.00385	.07088	-.03943	1.3475	1.3549	1.5382	.6444	.7150	.7313	.5405	1.2719
	-.1549	2.0102	.9854	.6450	.2633	1.4605	1.1972	1.5122	35.4613	.0039	-.0094
.875	.00217	.05132	-.02808	1.2343	1.5094	1.4023	.6886	.5709	.7291	.5389	1.2680
	-.2459	1.9651	.8999	.6366	.2338	1.3423	1.1085	1.6663	36.4986	.0024	-.0062
.900	.00102	.03371	-.01816	1.0927	1.6969	1.2833	.7402	.4344	.7324	.5413	1.2737
	-.3564	1.9230	.8003	.6264	.1895	1.2137	1.0242	1.8021	37.3441	.0011	-.0038

X	BARRIER	SURFACE	COULOMB	RHO	LAMBDA	INPERP	INPAR	QUADRUPOLE	R1	R2	SCALE	
	Z1	Z2	Z CUT	FMASS	ZCM1	ZCM2	COMPACT	OPENING	ANGLE	STIFF1	STIFF2	
ASYMMETRY DELTA	.175											
.300	.15768	.23477	-.12849	1.3522	.2748	2.6862	.6854	1.6006	.8973	.6300	1.5272	
	.6526	1.6101	1.2133	.7423	.0250	2.0453	2.0204	.0199	32.3856	.0738	-4.5825	
.350	.14465	.23709	-.13205	1.3932	.3023	2.7807	.6784	1.6819	.8949	.6283	1.5232	
	.6271	1.6865	1.2468	.7419	.0319	2.0963	2.0644	.0288	31.2726	.0719	-3.3928	
.400	.13128	.23966	-.13548	1.4357	.3301	2.8757	.6702	1.7644	.8921	.6264	1.5185	
	.6012	1.7640	1.2808	.7414	.0401	2.1466	2.1066	.0394	29.9982	.0671	-2.6090	
.450	.11756	.24258	-.13891	1.4813	.3589	2.9744	.6607	1.8510	.8888	.6240	1.5128	
	.5743	1.8454	1.3165	.7408	.0499	2.1982	2.1482	.0520	28.5193	.0605	-2.0514	
.500	.10349	.24601	-.14252	1.5322	.3897	3.0807	.6494	1.9450	.9847	.6211	1.5058	
	.5455	1.9337	1.3555	.7400	.0622	2.2528	2.1906	.0669	26.7795	.0528	-1.6309	
.550	.08904	.25021	-.14652	1.5916	.4233	3.2000	.6358	2.0514	.8794	.6175	1.4969	
	.5139	2.0331	1.3997	.7389	.0777	2.3132	2.2355	.0847	24.7082	.0443	-1.3001	
.600	.07416	.25561	-.15120	1.6645	.4611	3.3411	.6190	2.1777	.8726	.6127	1.4853	
	.4783	2.1501	1.4525	.7375	.0981	2.3835	2.2854	.1062	22.2003	.0356	-1.0287	
.625	.06653	.25898	-.15396	1.7084	.4820	3.4241	.6090	2.2521	.8684	.6097	1.4781	
	.4585	2.2182	1.4836	.7366	.1110	2.4243	2.3133	.1187	20.7402	.0312	-.9094	
.650	.05876	.26299	-.15710	1.7595	.5046	3.5190	.5977	2.3370	.8634	.6062	1.4696	
	.4371	2.2949	1.5192	.7356	.1261	2.4704	2.3443	.1324	19.1175	.0270	-.7985	
.675	.05081	.26784	-.16076	1.8198	.5292	3.6297	.5848	2.4359	.8575	.6021	1.4596	
	.4138	2.3827	1.5605	.7344	.1443	2.5236	2.3792	.1477	17.3075	.0230	-.6944	
.700	.04267	.27383	-.16512	1.8923	.5558	3.7618	.5701	2.5534	.8504	.5971	1.4475	
	.3884	2.4846	1.6092	.7329	.1664	2.5861	2.4197	.1645	15.2778	.0193	-.5953	
.725	.03429	.28133	-.17038	1.9809	.5847	3.9228	.5533	2.6956	.8419	.5911	1.4330	
	.3609	2.6044	1.6677	.7313	.1933	2.6609	2.4676	.1828	12.9926	.0160	-.4993	
.750	.02561	.29080	-.17679	2.0900	.6153	4.1226	.5344	2.8705	.8318	.5840	1.4158	
	.3316	2.7460	1.7384	.7294	.2260	2.7516	2.5256	.2021	10.3855	.0134	-.4045	
.775	.01658	.30270	-.18459	2.2235	.6466	4.3727	.5138	3.0871	.8201	.5758	1.3958	
	.3016	2.9120	1.8234	.7274	.2648	2.8618	2.5969	.2209	7.2977	.0116	-.3107	
.800	.00713	.31722	-.19381	2.3810	.6759	4.6851	.4931	3.3536	.8076	.5670	1.3747	
	.2733	3.1008	1.9229	.7256	.3079	2.9938	2.6859	.2355	3.2806	.0110	-.2222	
.825	-.00281	.33378	-.20400	2.5500	.6984	5.0672	.4754	3.6735	.7968	.5595	1.3563	
	.2511	3.3005	2.0319	.7245	.3480	3.1459	2.7979	.2381	-1.8708	.0124	-.1639	
.850	-.01327	.35045	-.21395	2.7071	.7105	5.5065	.4643	4.0337	.7904	.5549	1.3453	
	.2382	3.4906	2.1396	.7249	.3756	3.3084	2.9328	.2231	-3.8430	.0138	-.1897	
.875	-.02419	.36555	-.22270	2.8459	.7164	5.9695	.4583	4.4090	.7872	.5527	1.3400	
	.2312	3.6646	2.2404	.7260	.3926	3.4696	3.0770	.1990	-1.4987	.0128	-.3384	
.900	-.03552	.37907	-.23032	2.9759	.7210	6.4403	.4542	4.7889	.7851	.5512	1.3363	
	.2257	3.8295	2.3363	.7274	.4056	3.6264	3.2208	.1750	.7048	.0112	-.6379	

X	BARRIER Z1	SURFACE Z2	COULOMB Z CUT	RHO	LAMBDA FMASS	INPERP ZCM1	INPAR ZCM2	QUADRUPOLE COMPACT	R1 OPENING	R2 ANGLE	SCALE STIFF1	STIFF2
ASYMMETRY DELTA .200												
.350	.14206	.22654	-.12069	1.3782	.2925	2.5832	.7012	1.5056	.9072	.6048	1.5120	
	.6446	1.6586	1.2503	.7705	.0295	2.0607	2.0313	.0259	31.7072	.0711	-3.6177	
.400	.12983	.22899	-.12395	1.4192	.3194	2.6690	.6935	1.5804	.9046	.6031	1.5077	
	.6193	1.7329	1.2838	.7701	.0369	2.1100	2.0731	.0355	30.4716	.0668	-2.7917	
.450	.11727	.23180	-.12725	1.4632	.3473	2.7592	.6846	1.6597	.9016	.6011	1.5027	
	.5931	1.8110	1.3192	.7695	.0459	2.1607	2.1149	.0468	29.0241	.0607	-2.2133	
.500	.10437	.23514	-.13077	1.5124	.3769	2.8576	.6740	1.7468	.8979	.5986	1.4964	
	.5652	1.8959	1.3579	.7688	.0569	2.2150	2.1581	.0600	27.3088	.0532	-1.7857	
.550	.09110	.23928	-.13471	1.5698	.4091	2.9700	.6613	1.8469	.8932	.5955	1.4886	
	.5346	1.9919	1.4021	.7678	.0708	2.2757	2.2049	.0755	25.2450	.0450	-1.4559	
.600	.07740	.24469	-.13940	1.6403	.4450	3.1055	.6457	1.9678	.8872	.5914	1.4786	
	.5004	2.1051	1.4552	.7666	.0888	2.3472	2.2583	.0935	22.7405	.0364	-1.1958	
.625	.07037	.24809	-.14218	1.6827	.4647	3.1865	.6365	2.0400	.8834	.5890	1.4724	
	.4816	2.1710	1.4866	.7658	.1001	2.3891	2.2890	.1035	21.2844	.0321	-1.0867	
.650	.06318	.25216	-.14537	1.7317	.4858	3.2802	.6262	2.1232	.8791	.5861	1.4652	
	.4613	2.2453	1.5225	.7649	.1132	2.4368	2.3237	.1141	19.6768	.0279	-.9900	
.675	.05582	.25708	-.14908	1.7893	.5083	3.3907	.6146	2.2209	.8741	.5828	1.4569	
	.4396	2.3301	1.5641	.7640	.1286	2.4922	2.3635	.1253	17.9081	.0240	-.9056	
.700	.04826	.26313	-.15348	1.8577	.5323	3.5234	.6015	2.3375	.8683	.5789	1.4472	
	.4163	2.4279	1.6131	.7629	.1469	2.5574	2.4105	.1366	15.9745	.0204	-.8342	
.725	.04046	.27059	-.15871	1.9395	.5574	3.6855	.5871	2.4787	.8616	.5744	1.4360	
	.3918	2.5414	1.6711	.7617	.1684	2.6352	2.4668	.1475	13.9027	.0172	-.7783	
.750	.03237	.27974	-.16491	2.0370	.5830	3.8848	.5716	2.6506	.8541	.5694	1.4234	
	.3667	2.6726	1.7397	.7605	.1931	2.7282	2.5352	.1567	11.7623	.0147	-.7433	
.775	.02395	.29068	-.17208	2.1505	.6077	4.1282	.5556	2.8581	.8460	.5640	1.4100	
	.3421	2.8212	1.8193	.7595	.2203	2.8381	2.6178	.1629	9.6723	.0128	-.7348	
.800	.01515	.30314	-.18000	2.2775	.6302	4.4175	.5402	3.1018	.8380	.5586	1.3966	
	.3196	2.9839	1.9085	.7587	.2486	2.9639	2.7154	.1643	7.8320	.0116	-.7728	
.825	.00595	.31650	-.18822	2.4126	.6494	4.7481	.5265	3.3773	.8306	.5537	1.3843	
	.3001	3.1544	2.0038	.7584	.2758	3.1019	2.8261	.1605	6.4123	.0108	-.8774	
.850	-.00367	.33003	-.19630	2.5505	.6652	5.1110	.5149	3.6769	.8241	.5494	1.3735	
	.2838	3.3270	2.1018	.7585	.3008	3.2472	2.9464	.1523	5.4780	.0102	-1.0793	
.875	-.01368	.34325	-.20396	2.6884	.6785	5.4983	.5051	3.9946	.8185	.5457	1.3642	
	.2700	3.4988	2.2004	.7588	.3234	3.3962	3.0728	.1413	4.9377	.0095	-1.4166	
.900	-.02406	.35600	-.21114	2.8262	.6901	5.9062	.4966	4.3277	.8135	.5423	1.3558	
	.2581	3.6695	2.2990	.7594	.3444	3.5472	3.2028	.1292	4.6323	.0088	-1.9378	
ASYMMETRY DELTA .225												
.350	.13891	.21523	-.10903	1.3617	.2816	2.3874	.7250	1.3300	.9184	.5810	1.4995	
	.6625	1.6272	1.2507	.7972	.0269	2.0217	1.9948	.0229	32.1826	.0700	-3.8898	
.400	.12786	.21751	-.11207	1.4010	.3076	2.4633	.7179	1.3964	.9161	.5796	1.4957	
	.6379	1.6978	1.2835	.7968	.0336	2.0695	2.0358	.0316	31.0075	.0665	-3.0061	
.450	.11650	.22015	-.11517	1.4430	.3344	2.5435	.7096	1.4671	.9134	.5779	1.4913	
	.6125	1.7719	1.3181	.7963	.0416	2.1188	2.0771	.0416	29.6159	.0609	-2.3967	

X	BARRIER	SURFACE	COULOMB	RHO	LAMBDA	INPERP	INPAR	QUADRUPOLE	R1	R2	SCALE	
	Z1	Z2	Z CUT	FMASS	ZCM1	ZCM2	COMPACT	OPENING	ANGLE	STIFF1	STIFF2	
.500	.10482	.22331	-.11849	1.4899	.3628	2.6316	.6998	1.5455	.9101	.5758	1.4858	
	.5856	1.8526	1.3559	.7956	.0514	2.1717	2.1203	.0533	27.9550	.0538	-1.9542	
.550	.09278	.22724	-.12223	1.5445	.3935	2.7331	.6881	1.6360	.9059	.5731	1.4791	
	.5562	1.9437	1.3992	.7948	.0637	2.2312	2.1675	.0667	25.9458	.0459	-1.6210	
.600	.08034	.23239	-.12670	1.6111	.4276	2.8564	.6738	1.7461	.9007	.5698	1.4705	
	.5235	2.0509	1.4511	.7937	.0795	2.3015	2.2220	.0819	23.5028	.0374	-1.3676	
.625	.07395	.23562	-.12934	1.6511	.4462	2.9304	.6654	1.8120	.8974	.5678	1.4652	
	.5056	2.1132	1.4817	.7930	.0892	2.3428	2.2536	.0901	22.0852	.0332	-1.2662	
.650	.06740	.23948	-.13236	1.6970	.4659	3.0160	.6560	1.8880	.8937	.5654	1.4592	
	.4864	2.1833	1.5167	.7923	.1005	2.3897	2.2892	.0987	20.5274	.0291	-1.1809	
.675	.06070	.24411	-.13586	1.7505	.4869	3.1167	.6455	1.9769	.8895	.5627	1.4522	
	.4659	2.2629	1.5570	.7915	.1136	2.4440	2.3304	.1073	18.8274	.0251	-1.1126	
.700	.05381	.24974	-.13995	1.8135	.5092	3.2371	.6338	2.0826	.8846	.5596	1.4442	
	.4440	2.3542	1.6042	.7907	.1290	2.5076	2.3786	.1157	16.9917	.0215	-1.0639	
.725	.04669	.25660	-.14476	1.8881	.5324	3.3828	.6210	2.2094	.8790	.5561	1.4350	
	.4210	2.4594	1.6595	.7898	.1469	2.5829	2.4360	.1233	15.0599	.0183	-1.0396	
.750	.03932	.26485	-.15035	1.9758	.5560	3.5595	.6071	2.3619	.8727	.5521	1.4249	
	.3974	2.5800	1.7243	.7889	.1672	2.6718	2.5046	.1293	13.1079	.0157	-1.0485	
.775	.03165	.27455	-.15671	2.0771	.5792	3.7717	.5928	2.5431	.8660	.5479	1.4139	
	.3740	2.7160	1.7988	.7882	.1897	2.7755	2.5858	.1327	11.2483	.0136	-1.1018	
.800	.02364	.28550	-.16366	2.1908	.6011	4.0208	.5787	2.7537	.8591	.5435	1.4027	
	.3518	2.8652	1.8822	.7876	.2135	2.8934	2.6799	.1328	9.5975	.0121	-1.2156	
.825	.01527	.29730	-.17092	2.3138	.6210	4.3042	.5653	2.9911	.8524	.5393	1.3917	
	.3314	3.0240	1.9723	.7873	.2376	3.0229	2.7853	.1295	8.2576	.0109	-1.4201	
.850	.00654	.30950	-.17821	2.4431	.6386	4.6172	.5531	3.2513	.8460	.5352	1.3812	
	.3132	3.1885	2.0669	.7873	.2612	3.1609	2.8997	.1234	7.2368	.0099	-1.7468	
.875	-.00254	.32178	-.18533	2.5767	.6545	4.9560	.5420	3.5312	.8400	.5314	1.3714	
	.2968	3.3567	2.1644	.7875	.2842	3.3051	3.0209	.1155	6.4814	.0091	-2.2397	
.900	-.01198	.33400	-.19221	2.7143	.6689	5.3188	.5317	3.8297	.8342	.5278	1.3619	
	.2819	3.5277	2.2643	.7879	.3067	3.4540	3.1473	.1066	5.9105	.0082	-2.9583	
ASYMMETRY DELTA .250												
.400	.12531	.20544	-.10015	1.3814	.2949	2.2647	.7426	1.2177	.9266	.5560	1.4826	
	.6569	1.6595	1.2800	.8214	.0303	2.0256	1.9953	.0276	31.5942	.0660	-3.2598	
.450	.11516	.20786	-.10300	1.4212	.3205	2.3342	.7350	1.2794	.9242	.5545	1.4787	
	.6325	1.7292	1.3135	.8209	.0374	2.0730	2.0356	.0366	30.2808	.0610	-2.6062	
.500	.10471	.21076	-.10605	1.4653	.3475	2.4109	.7261	1.3478	.9213	.5528	1.4741	
	.6067	1.8047	1.3499	.8204	.0460	2.1238	2.0778	.0468	28.7052	.0545	-2.1393	
.550	.09393	.21437	-.10949	1.5163	.3766	2.4992	.7155	1.4269	.9177	.5506	1.4683	
	.5787	1.8898	1.3915	.8197	.0567	2.1808	2.1241	.0585	26.7906	.0469	-1.7949	
.600	.08279	.21907	-.11357	1.5781	.4088	2.6063	.7026	1.5230	.9131	.5479	1.4610	
	.5476	1.9895	1.4410	.8188	.0703	2.2480	2.1777	.0714	24.4578	.0387	-1.5407	
.625	.07705	.22202	-.11597	1.6149	.4263	2.6704	.6950	1.5804	.9104	.5462	1.4566	
	.5306	2.0471	1.4701	.8182	.0786	2.2872	2.2086	.0784	23.1045	.0346	-1.4427	
.650	.07118	.22550	-.11870	1.6569	.4448	2.7443	.6865	1.6462	.9072	.5443	1.4515	
	.5124	2.1116	1.5031	.8177	.0882	2.3317	2.2435	.0855	21.6190	.0305	-1.3638	

X	BARRIER Z1	SURFACE Z2	COULOMB Z CUT	RHO	LAMBDA FMASS	INPERP ZCM1	INPAR ZCM2	QUADRUPOLE COMPACT	R1 OPENING	R2 ANGLE	SCALE STIFF1	STIFF2
.675	.06517	.22966	-.12184	1.7056	.4645	2.8307	.6771	1.7229	.9036	.5421	1.4457	
.700	.05899	.23467	-.12549	1.7625	.4854	2.9334	.6666	2.2836	.0925	19.9978	.0265	-1.3055
.725	.05261	.24072	-.12973	1.8294	.5073	3.0567	.6550	2.3302	.0993	18.2556	.0229	-1.2707
.750	.04601	.24798	-.13465	1.9079	.5299	3.2051	.6424	2.3852	.1053	16.4187	.0195	-1.2659
.775	.03914	.25650	-.14023	1.9991	.5526	3.3829	.6290	2.4504	.1100	14.5524	.0167	-1.3013
.800	.03198	.26620	-.14639	2.1024	.5747	3.5919	.6154	2.5271	.1127	12.7519	.0144	-1.3934
.825	.02449	.27684	-.15294	2.2165	.5956	3.8318	.6020	2.6159	.1129	11.0996	.0125	-1.5521
.850	.01668	.28810	-.15966	2.3394	.6150	4.1005	.5892	2.7159	.1105	9.6901	.0110	-1.8187
.875	.00853	.30437	-.16640	2.4695	.6329	4.3961	.5769	2.8256	.1059	8.5390	.0098	-2.2261
.900	.00004	.3216	-.17309	2.6066	.6496	4.7179	.5652	2.9434	.0996	7.6166	.0088	-2.8265
	.3042	3.3801	2.2210	.8138	.2760	3.3440	3.0680	.0925	6.8692	.0077	-3.6893	

ASYMMETRY DELTA .275

.400	.12217	.19295	-.08848	1.3607	.2813	2.0783	.7673	1.0488	.9361	.5323	1.4685	
.450	.06761	.16189	-.12739	.8439	.0270	1.9792	1.9522	.0238	32.2114	.0652	-3.5655	
.500	.11319	.19513	-.09104	1.3980	.3056	2.1372	.7604	1.1014	.9340	.5311	1.4652	
.550	.06528	.16837	-.13058	.8435	.0332	2.0241	1.9909	.0317	31.0000	.0611	-2.8497	
.600	.10396	.19773	-.09377	1.4390	.3312	2.2019	.7524	1.1596	.9315	.5297	1.4612	
.650	.06282	.17537	-.13405	.8431	.0407	2.0722	2.0315	.0406	29.5327	.0552	-2.3456	
.700	.09443	.20095	-.09684	1.4861	.3587	2.2763	.7429	1.2267	.9284	.5279	1.4563	
.750	.06017	.18319	-.13797	.8425	.0498	2.1257	2.0759	.0508	27.7508	.0481	-1.9803	
.800	.08457	.20511	-.10045	1.5424	.3888	2.3659	.7314	1.3076	.9245	.5257	1.4502	
.850	.05725	.19229	-.14260	.8418	.0614	2.1884	2.1270	.0620	25.5694	.0403	-1.7156	
.900	.07950	.20769	-.10256	1.5756	.4051	2.4191	.7247	1.3556	.9222	.5244	1.4465	
.950	.05565	.19751	-.14530	.8413	.0684	2.2248	2.1563	.0679	24.3025	.0363	-1.6157	
.400	.07431	.21072	-.10493	1.6133	.4225	2.4801	.7172	1.4103	.9195	.5229	1.4424	
.450	.05394	.20334	-.14834	.8409	.0765	2.2657	2.1892	.0739	22.9091	.0322	-1.5369	
.500	.06900	.21432	-.10765	1.6566	.4410	2.5509	.7088	1.4737	.9164	.5211	1.4376	
.550	.05211	.20989	-.15182	.8403	.0859	2.3125	2.2266	.0800	21.3844	.0282	-1.4807	
.600	.06354	.21863	-.11078	1.7069	.4606	2.6344	.6994	1.5480	.9129	.5191	1.4321	
.650	.05016	.21735	-.15583	.8398	.0967	2.3666	2.2699	.0857	19.7372	.0245	-1.4500	
.700	.05791	.22381	-.11441	1.7659	.4813	2.7340	.6890	1.6360	.9089	.5168	1.4257	
.750	.04807	.22590	-.16051	.8392	.1093	2.4299	2.3206	.0910	17.9843	.0210	-1.4517	
.800	.05209	.23002	-.11862	1.8353	.5031	2.8536	.6775	1.7409	.9043	.5142	1.4185	
.850	.04587	.23572	-.16597	.8386	.1239	2.5043	2.3804	.0952	16.1731	.0179	-1.4955	
.900	.04604	.23737	-.12344	1.9163	.5254	2.9971	.6650	1.8656	.8992	.5113	1.4105	
.950	.4359	2.4694	1.7231	.8381	.1406	2.5913	2.4508	.0979	14.3759	.0153	-1.5984	

X	BARRIER	SURFACE	COULOMB	RHO	LAMBDA	INPERP	INPAR	QUADRUPOLE	R1	R2	SCALE	
	Z1	Z2	Z CUT	FMASS	ZCM1	ZCM2	COMPACT	OPENING	ANGLE	STIFF1	STIFF2	
.800	.03973	.24589	-.12885	2.0096	.5478	3.1673	.6519	2.0123	.8936	.5081	1.4017	
	.4128	2.5958	1.7957	.8376	.1592	2.6920	2.5328	.0987	12.6712	.0131	-1.7751	
.825	.03315	.25545	-.13473	2.1149	.5697	3.3657	.6385	2.1818	.8876	.5047	1.3923	
	.3901	2.7356	1.8772	.8373	.1795	2.8060	2.6264	.0973	11.1440	.0113	-2.0641	
.850	.02625	.26586	-.14094	2.2311	.5907	3.5922	.6251	2.3737	.8814	.5012	1.3826	
	.3681	2.8870	1.9665	.8372	.2011	2.9321	2.7310	.0939	9.8337	.0098	-2.5036	
.875	.01905	.27690	-.14735	2.3574	.6107	3.8463	.6118	2.5876	.8750	.4976	1.3726	
	.3472	3.0486	2.0627	.8372	.2238	3.0690	2.8452	.0890	8.7337	.0085	-3.1521	
.900	.01152	.28847	-.15386	2.4932	.6297	4.1284	.5987	2.8237	.8685	.4938	1.3623	
	.3274	3.2195	2.1653	.8373	.2475	3.2159	2.9683	.0830	7.8097	.0073	-4.0907	

ASYMMETRY DELTA .300

.450	.11058	.18217	-.07955	1.3740	.2901	1.9563	.7853	.9368	.9429	.5077	1.4506	
	.6733	1.6366	1.2956	.8640	.0292	1.9730	1.9438	.0270	31.7517	.0609	-3.1396	
.500	.10251	.18445	-.08194	1.4118	.3141	2.0097	.7782	.9852	.9407	.5066	1.4473	
	.6501	1.7007	1.3281	.8637	.0356	2.0178	1.9822	.0348	30.4172	.0558	-2.5826	
.550	.09419	.18725	-.08461	1.4546	.3398	2.0706	.7698	1.0406	.9381	.5051	1.4432	
	.6252	1.7717	1.3645	.8632	.0434	2.0674	2.0241	.0436	28.7916	.0494	-2.1834	
.600	.08557	.19083	-.08771	1.5052	.3678	2.1431	.7597	1.1067	.9348	.5034	1.4382	
	.5979	1.8535	1.4071	.8626	.0531	2.1247	2.0717	.0533	26.7961	.0420	-1.8971	
.625	.08115	.19302	-.08950	1.5346	.3830	2.1858	.7538	1.1456	.9329	.5023	1.4352	
	.5830	1.9000	1.4316	.8623	.0589	2.1577	2.0987	.0584	25.6342	.0382	-1.7894	
.650	.07662	.19558	-.09151	1.5678	.3991	2.2342	.7473	1.1895	.9307	.5011	1.4318	
	.5672	1.9515	1.4591	.8619	.0656	2.1944	2.1288	.0637	24.3525	.0342	-1.7040	
.675	.07196	.19859	-.09378	1.6056	.4163	2.2901	.7400	1.2401	.9281	.4998	1.4279	
	.5502	2.0092	1.4902	.8615	.0733	2.2361	2.1628	.0689	22.9432	.0303	-1.6422	
.700	.06724	.20218	-.09639	1.6492	.4345	2.3553	.7318	1.2988	.9252	.4982	1.4234	
	.5319	2.0745	1.5259	.8611	.0822	2.2839	2.2017	.0741	21.4057	.0264	-1.6066	
.725	.06234	.20648	-.09940	1.7001	.4540	2.4326	.7226	1.3680	.9219	.4964	1.4182	
	.5123	2.1492	1.5673	.8606	.0926	2.3395	2.2469	.0788	19.7529	.0228	-1.6021	
.750	.05729	.21164	-.10290	1.7600	.4747	2.5251	.7123	1.4502	.9180	.4943	1.4123	
	.4913	2.2350	1.6156	.8601	.1048	2.4048	2.3000	.0829	18.0070	.0194	-1.6384	
.775	.05205	.21781	-.10694	1.8304	.4964	2.6363	.7009	1.5484	.9136	.4919	1.4055	
	.4691	2.3339	1.6722	.8596	.1189	2.4815	2.3626	.0860	16.2192	.0165	-1.7299	
.800	.04658	.22509	-.11157	1.9127	.5188	2.7698	.6885	1.6650	.9086	.4892	1.3979	
	.4459	2.4471	1.7379	.8592	.1351	2.5713	2.4363	.0875	14.4632	.0139	-1.9019	
.825	.04088	.23350	-.11674	2.0079	.5415	2.9282	.6753	1.8023	.9031	.4863	1.3894	
	.4223	2.5750	1.8133	.8589	.1533	2.6752	2.5219	.0873	12.7986	.0118	-2.1680	
.850	.03490	.24296	-.12239	2.1159	.5640	3.1134	.6615	1.9615	.8972	.4831	1.3802	
	.3987	2.7174	1.8983	.8587	.1735	2.7931	2.6196	.0852	11.3069	.0100	-2.5890	
.875	.02863	.25333	-.12840	2.2364	.5860	3.3264	.6475	2.1431	.8908	.4797	1.3705	
	.3756	2.8732	1.9923	.8586	.1955	2.9244	2.7290	.0814	10.0030	.0085	-3.2213	
.900	.02206	.26452	-.13470	2.3696	.6074	3.5686	.6332	2.3483	.8841	.4761	1.3602	
	.3531	3.0421	2.0949	.8586	.2192	3.0687	2.8496	.0765	8.8775	.0071	-4.1516	

X	BARRIER	SURFACE	COULOMB	RHO	LAMBDA	INPERP	INPAR	QUADRUPOLE	R1	R2	SCALE
	Z1	Z2	Z CUT	FMASS	ZCM1	ZCM2	COMPACT	OPENING	ANGLE	STIFF1	STIFF2
ASYMMETRY DELTA .325											
.450	.10733	.16917	-.06872	1.3495	.2740	1.7941	.8093	.7878	.9509	.4844	1.4353
	.6939	1.5887	1.2832	.8825	.0254	1.9203	1.8949	.0226	32.5080	.0601	-3.4962
.500	.10035	.17113	-.07078	1.3840	.2964	1.8372	.8030	.8273	.9490	.4835	1.4325
	.6721	1.6469	1.3135	.8823	.0308	1.9618	1.9309	.0294	31.3248	.0562	-2.8640
.550	.09316	.17351	-.07305	1.4226	.3203	1.8858	.7958	.8720	.9468	.4823	1.4292
	.6490	1.7107	1.3469	.8819	.0373	2.0071	1.9697	.0370	29.8717	.0506	-2.4152
.600	.08573	.17651	-.07565	1.4674	.3462	1.9430	.7870	.9248	.9441	.4810	1.4251
	.6237	1.7832	1.3854	.8814	.0454	2.0587	2.0133	.0454	28.0906	.0439	-2.0941
.625	.08191	.17833	-.07713	1.4932	.3601	1.9762	.7820	.9553	.9425	.4801	1.4227
	.6100	1.8240	1.4074	.8812	.0502	2.0880	2.0378	.0498	27.0494	.0402	-1.9723
.650	.07802	.18043	-.07878	1.5219	.3749	2.0135	.7764	.9897	.9407	.4792	1.4199
	.5954	1.8689	1.4317	.8809	.0556	2.1204	2.0648	.0544	25.8966	.0364	-1.8741
.675	.07403	.18288	-.08063	1.5544	.3906	2.0561	.7701	1.0288	.9386	.4782	1.4168
	.5798	1.9187	1.4590	.8806	.0618	2.1567	2.0948	.0591	24.6227	.0326	-1.7997
.700	.06995	.18578	-.08274	1.5915	.4074	2.1054	.7631	1.0738	.9363	.4770	1.4132
	.5630	1.9747	1.4901	.8802	.0690	2.1980	2.1289	.0637	23.2214	.0288	-1.7507
.725	.06575	.18923	-.08516	1.6345	.4255	2.1632	.7552	1.1264	.9335	.4756	1.4091
	.5449	2.0384	1.5258	.8799	.0774	2.2456	2.1682	.0681	21.6927	.0250	-1.7313
.750	.06143	.19338	-.08797	1.6848	.4448	2.2319	.7462	1.1885	.9304	.4740	1.4043
	.5253	2.1115	1.5674	.8795	.0873	2.3011	2.2139	.0722	20.0468	.0215	-1.7485
.775	.05695	.19836	-.09124	1.7441	.4654	2.3145	.7362	1.2627	.9267	.4721	1.3988
	.5042	2.1961	1.6163	.8791	.0988	2.3666	2.2678	.0755	18.3127	.0182	-1.8122
.800	.05229	.20435	-.09504	1.8144	.4872	2.4145	.7249	1.3517	.9224	.4699	1.3924
	.4817	2.2941	1.6737	.8787	.1124	2.4440	2.3316	.0778	16.5324	.0152	-1.9442
.825	.04743	.21146	-.09941	1.8974	.5101	2.5352	.7124	1.4582	.9176	.4674	1.3850
	.4579	2.4072	1.7410	.8783	.1282	2.5351	2.4070	.0788	14.7681	.0127	-2.1667
.850	.04234	.21975	-.10436	1.9943	.5336	2.6799	.6989	1.5848	.9121	.4647	1.3768
	.4333	2.5367	1.8190	.8780	.1463	2.6415	2.4953	.0781	13.0966	.0105	-2.5247
.875	.03699	.22920	-.10983	2.1060	.5573	2.8514	.6844	1.7336	.9060	.4616	1.3676
	.4082	2.6829	1.9081	.8779	.1668	2.7638	2.5971	.0757	11.5672	.0087	-3.0779
.900	.03135	.23978	-.11579	2.2333	.5810	3.0525	.6692	1.9066	.8993	.4582	1.3575
	.3832	2.8461	2.0085	.8778	.1897	2.9024	2.7127	.0719	10.2028	.0070	-3.9150
ASYMMETRY DELTA .350											
.500	.09749	.15794	-.06045	1.3562	.2784	1.6857	.8266	.6872	.9564	.4605	1.4169
	.6941	1.5932	1.2971	.8989	.0265	1.9049	1.8784	.0243	32.2241	.0560	-3.2100
.550	.09135	.15993	-.06234	1.3907	.3004	1.7237	.8204	.7227	.9546	.4596	1.4142
	.6727	1.6500	1.3276	.8986	.0318	1.9458	1.9140	.0308	30.9599	.0515	-2.6915
.600	.08502	.16239	-.06448	1.4301	.3241	1.7678	.8130	.7639	.9524	.4586	1.4109
	.6495	1.7136	1.3620	.8983	.0384	1.9918	1.9534	.0381	29.4007	.0456	-2.3205
.625	.08176	.16386	-.06568	1.4524	.3368	1.7930	.8087	.7875	.9511	.4579	1.4090
	.6370	1.7491	1.3814	.8981	.0423	2.0175	1.9752	.0419	28.4936	.0423	-2.1776
.650	.07845	.16555	-.06700	1.4770	.3503	1.8211	.8040	.8137	.9496	.4572	1.4068
	.6237	1.7876	1.4026	.8979	.0466	2.0456	1.9990	.0459	27.4824	.0388	-2.0603

X	BARRIER	SURFACE	COULOMB	RHO	LAMBDA	INPERP	INPAR	QUADRUPOLE	R1	R2	SCALE	
	Z1	Z2	Z CUT	FMASS	ZCM1	ZCM2	COMPACT	OPENING	ANGLE	STIFF1	STIFF2	
.675	.07506	.16750	-.06847	1.5045	.3645	1.8527	.7988	.8432	.9480	.4564	1.4044	
	.6096	1.8300	1.4262	.8976	.0516	2.0767	2.0251	.0500	26.3603	.0351	-1.9671	
.700	.07160	.16978	-.07013	1.5355	.3797	1.8888	.7929	.8768	.9461	.4555	1.4016	
	.5944	1.8773	1.4527	.8974	.0573	2.1117	2.0544	.0542	25.1180	.0314	-1.8985	
.725	.06804	.17247	-.07202	1.5711	.3961	1.9307	.7863	.9156	.9439	.4545	1.3984	
	.5780	1.9305	1.4830	.8971	.0639	2.1516	2.0877	.0583	23.7480	.0277	-1.8568	
.750	.06439	.17568	-.07420	1.6124	.4137	1.9800	.7787	.9610	.9414	.4533	1.3947	
	.5602	1.9912	1.5179	.8968	.0716	2.1977	2.1261	.0622	22.2480	.0240	-1.8466	
.775	.06062	.17955	-.07673	1.6609	.4327	2.0389	.7702	1.0150	.9384	.4518	1.3903	
	.5409	2.0612	1.5586	.8964	.0807	2.2517	2.1709	.0658	20.6244	.0205	-1.8762	
.800	.05671	.18424	-.07971	1.7185	.4532	2.1101	.7604	1.0797	.9350	.4502	1.3852	
	.5198	2.1428	1.6068	.8961	.0916	2.3156	2.2241	.0688	18.8996	.0172	-1.9573	
.825	.05264	.18993	-.08321	1.7874	.4753	2.1969	.7493	1.1582	.9309	.4482	1.3792	
	.4969	2.2384	1.6640	.8958	.1045	2.3920	2.2875	.0708	17.1103	.0142	-2.1161	
.850	.04838	.19677	-.08729	1.8699	.4988	2.3034	.7367	1.2533	.9262	.4460	1.3722	
	.4723	2.3504	1.7320	.8955	.1198	2.4831	2.3633	.0715	15.3081	.0116	-2.3792	
.875	.04390	.20492	-.09202	1.9684	.5235	2.4335	.7227	1.3686	.9207	.4433	1.3640	
	.4463	2.4811	1.8123	.8952	.1378	2.5914	2.4535	.0707	13.5691	.0093	-2.8053	
.900	.03917	.21447	-.09739	2.0848	.5491	2.5916	.7072	1.5075	.9144	.4403	1.3547	
	.4191	2.6324	1.9063	.8951	.1590	2.7188	2.5598	.0684	11.9392	.0073	-3.4772	

ASYMMETRY DELTA .375

.550	.08879	.14665	-.05260	1.3594	.2803	1.5844	.8434	.5928	.9615	.4370	1.3985	
	.6961	1.5908	1.3070	.9135	.0269	1.8846	1.8577	.0251	32.0141	.0518	-3.0355	
.600	.08345	.14864	-.05433	1.3939	.3019	1.6178	.8372	.6245	.9597	.4362	1.3959	
	.6750	1.6462	1.3376	.9132	.0322	1.9252	1.8930	.0314	30.6882	.0470	-2.5951	
.625	.08071	.14982	-.05529	1.4130	.3134	1.6366	.8336	.6424	.9586	.4357	1.3944	
	.6637	1.6766	1.3546	.9131	.0353	1.9475	1.9122	.0347	29.9136	.0441	-2.4233	
.650	.07792	.15115	-.05633	1.4339	.3255	1.6573	.8298	.6620	.9575	.4352	1.3927	
	.6518	1.7094	1.3730	.9129	.0387	1.9717	1.9330	.0382	29.0498	.0410	-2.2798	
.675	.07507	.15267	-.05747	1.4570	.3383	1.6803	.8254	.6839	.9562	.4346	1.3908	
	.6392	1.7452	1.3931	.9127	.0426	1.9981	1.9555	.0418	28.0887	.0377	-2.1618	
.700	.07217	.15442	-.05875	1.4826	.3519	1.7062	.8206	.7084	.9547	.4340	1.3887	
	.6256	1.7845	1.4155	.9125	.0471	2.0274	1.9803	.0454	27.0198	.0342	-2.0683	
.725	.06920	.15646	-.06018	1.5116	.3664	1.7358	.8152	.7365	.9530	.4332	1.3862	
	.6111	1.8282	1.4406	.9123	.0521	2.0603	2.0081	.0492	25.8326	.0307	-1.9996	
.750	.06615	.15888	-.06182	1.5449	.3821	1.7701	.8091	.7688	.9511	.4323	1.3834	
	.5953	1.8776	1.4693	.9121	.0580	2.0977	2.0397	.0529	24.5176	.0270	-1.9583	
.775	.06301	.16177	-.06372	1.5835	.3991	1.8106	.8021	.8068	.9488	.4313	1.3801	
	.5781	1.9341	1.5024	.9118	.0650	2.1411	2.0761	.0565	23.0684	.0234	-1.9489	
.800	.05977	.16527	-.06594	1.6290	.4176	1.8591	.7941	.8520	.9461	.4301	1.3762	
	.5591	1.9995	1.5413	.9116	.0732	2.1920	2.1188	.0598	21.4847	.0199	-1.9801	
.825	.05641	.16954	-.06856	1.6835	.4379	1.9181	.7848	.9067	.9430	.4286	1.3716	
	.5382	2.0764	1.5875	.9113	.0832	2.2528	2.1696	.0625	19.7768	.0166	-2.0646	
.850	.05291	.17479	-.07170	1.7495	.4601	1.9911	.7740	.9737	.9392	.4269	1.3661	
	.5152	2.1676	1.6431	.9110	.0952	2.3261	2.2310	.0645	17.9726	.0135	-2.2305	

X	BARRIER Z1	SURFACE Z2	COULOMB Z CUT	RHO	LAMBDA FMASS	INPERP ZCM1	INPAR ZCM2	QUADRUPOLE COMPACT	R1 OPENING	R2 ANGLE	SCALE STIFF1	STIFF2
.875	.04923	.18126	-.07545	1.8302	.4843	2.0822	.7614	1.0566	.9346	.4248	1.3594	
.900	.04535	.18921	-.07992	1.7105	.9107	1.098	2.4154	2.3056	.0654	16.1079	.0107	-2.5105
	.4621	2.4077	1.7924	.9105	.5105	2.1968	.7469	1.1599	.9291	.4223	1.3514	
					.1278	2.5244	2.3966	.0648	14.2536		.0082	-2.9756
ASYMMETRY DELTA .400												
.625	.07880	.13632	-.04602	1.3755	.2901	1.5055	.8566	.5191	.9652	.4137	1.3789	
.650	.07648	.13735	-.04683	1.3931	.3009	1.5205	.8534	.5337	.9643	.4133	.0455	-2.7346
.675	.07412	.13852	-.04770	1.4124	.3123	1.5370	.8499	.5496	.9633	.4128	.0429	-2.5560
.700	.07171	.13984	-.04867	1.4335	.3243	1.5553	.8461	.5674	.9622	.4124	.0401	-2.4058
.725	.06925	.14137	-.04974	1.4570	.3371	1.5759	.8418	.5873	.9609	.4118	.0370	-2.2814
.750	.06673	.14315	-.05094	1.4834	.3508	1.5993	.8369	.6099	.9594	.4112	.0337	-2.1816
.775	.06415	.14525	-.05232	1.5137	.3657	1.6264	.8314	.6360	.9577	.4105	.0303	-2.1066
.800	.06150	.14775	-.05391	1.5487	.3818	1.6584	.8251	.6666	.9558	.4096	.0268	-2.0583
.825	.05876	.15080	-.05578	1.5902	.3996	1.6967	.8178	.7032	.9534	.4086	.0233	-2.0410
.850	.05591	.15454	-.05802	1.6401	.4193	1.7436	.8092	.7476	.9506	.4074	.0197	-2.0624
.875	.05295	.15922	-.06073	1.7013	.4413	1.8023	.7989	.8027	.9471	.4059	.0163	-2.1350
.900	.04983	.16514	-.06406	1.7778	.4659	1.8773	.7867	.8725	.9428	.4041	.0131	-2.2852
	.5112	2.1864	1.6762	.9243	.0983	2.3324	2.2342	.0601	17.2263		.0101	-2.5519
ASYMMETRY DELTA .425												
.675	.07227	.12514	-.03916	1.3709	.2868	1.4198	.8721	.4381	.9695	.3912	1.3607	
.700	.07029	.12613	-.03988	1.3883	.2974	1.4326	.8690	.4508	.9686	.3908	.0418	-2.7283
.725	.06828	.12725	-.04067	1.4073	.3085	1.4467	.8657	.4649	.9677	.3905	.0393	-2.5653
.750	.06622	.12854	-.04155	1.4283	.3204	1.4626	.8619	.4805	.9666	.3900	.0365	-2.4281
.775	.06412	.13003	-.04253	1.4519	.3331	1.4805	.8577	.4983	.9653	.3895	.0335	-2.3158
.800	.06197	.13179	-.04364	1.4786	.3469	1.5012	.8528	.5187	.9639	.3889	.0303	-2.2280
	.6362	1.7530	1.4253	.9371	.0452	1.9728	1.9276	.0419	26.7088		.0270	-2.1657

X	BARRIER Z1	SURFACE Z2	COULOMB Z CUT	RHO	LAMBDA FMASS	INPERP ZCM1	INPAR ZCM2	QUADRUPOLE COMPACT	R1 OPENING	R2 ANGLE	SCALE STIFF1	STIFF2
.825	.05975	.13388	-.04493	1.5096	.3620	1.5255	.8473	.5425	.9622	.3883	1.3505	
	.6209	1.7980	1.4526	.9370	.0503	2.0078	1.9575	.0450	25.4453	.0235	-2.1322	
.850	.05747	.13642	-.04644	1.5461	.3787	1.5545	.8409	.5709	.9602	.3875	1.3477	
	.6039	1.8502	1.4846	.9368	.0564	2.0489	1.9925	.0480	24.0271	.0200	-2.1331	
.875	.05510	.13956	-.04826	1.5900	.3973	1.5901	.8332	.6055	.9578	.3865	1.3443	
	.5848	1.9120	1.5230	.9366	.0639	2.0981	2.0343	.0508	22.4446	.0166	-2.1807	
.900	.05264	.14352	-.05049	1.6444	.4184	1.6349	.8240	.6487	.9548	.3853	1.3401	
	.5629	1.9871	1.5701	.9364	.0732	2.1588	2.0856	.0533	20.6839	.0132	-2.2954	

ASYMMETRY DELTA .450

.750	.06473	.11504	-.03354	1.3791	.2912	1.3543	.8840	.3763	.9726	.3689	1.3415	
	.6943	1.5935	1.3413	.9476	.0294	1.8338	1.8044	.0281	30.7316	.0360	-2.6172	
.775	.06304	.11609	-.03423	1.3975	.3020	1.3662	.8808	.3883	.9717	.3686	1.3403	
	.6835	1.6211	1.3580	.9476	.0321	1.8551	1.8230	.0308	29.9365	.0334	-2.4851	
.800	.06131	.11731	-.03500	1.4181	.3136	1.3795	.8772	.4019	.9707	.3682	1.3389	
	.6719	1.6515	1.3765	.9475	.0352	1.8786	1.8434	.0335	29.0481	.0305	-2.3779	
.825	.05953	.11872	-.03587	1.4412	.3262	1.3948	.8731	.4173	.9695	.3677	1.3372	
	.6593	1.6855	1.3972	.9474	.0387	1.9050	1.8663	.0363	28.0494	.0274	-2.2950	
.850	.05772	.12040	-.03687	1.4677	.3399	1.4125	.8685	.4352	.9681	.3672	1.3354	
	.6454	1.7239	1.4209	.9472	.0429	1.9350	1.8922	.0392	26.9236	.0242	-2.2384	
.875	.05584	.12243	-.03805	1.4987	.3551	1.4335	.8630	.4564	.9665	.3666	1.3331	
	.6300	1.7682	1.4485	.9471	.0478	1.9701	1.9223	.0420	25.6506	.0208	-2.2121	
.900	.05391	.12492	-.03945	1.5358	.3722	1.4592	.8565	.4821	.9645	.3659	1.3304	
	.6125	1.8206	1.4814	.9470	.0538	2.0118	1.9579	.0449	24.2065	.0174	-2.2242	

ASYMMETRY DELTA .475

.825	.05826	.10512	-.02840	1.3831	.2927	1.2955	.8953	.3201	.9755	.3472	1.3227	
	.6949	1.5887	1.3491	.9563	.0297	1.8136	1.7839	.0282	30.3360	.0307	-2.5792	
.850	.05682	.10623	-.02906	1.4026	.3040	1.3064	.8920	.3315	.9745	.3469	1.3214	
	.6836	1.6173	1.3669	.9562	.0325	1.8360	1.8034	.0307	29.4805	.0280	-2.4688	
.875	.05535	.10752	-.02981	1.4247	.3162	1.3189	.8882	.3446	.9735	.3465	1.3199	
	.6713	1.6493	1.3869	.9561	.0358	1.8611	1.8254	.0333	28.5159	.0251	-2.3830	
.900	.05384	.10907	-.03068	1.4502	.3296	1.3336	.8838	.3599	.9722	.3460	1.3182	
	.6577	1.6858	1.4099	.9561	.0396	1.8900	1.8504	.0359	27.4194	.0220	-2.3235	

BUSINARO-GALLONE SADDLES

X	BARRIER	SURFACE	COULOMB	RHO	LAMBDA	INPERP	INPAR	QUADRUPOLE	R1	R2	SCALE
ASYMMETRY	Z1	Z2	Z CUT	FMASS	ZCM1	ZCM2	COMPACT	OPENING	ANGLE	STIFF1	STIFF2
.400	.13344	.27811	-.18083	1.4907	.3668	3.7477	.5797	2.5344	.7775	.7775	1.5550
0.	.4923	1.8256	1.1590	.5000	.0509	2.2671	2.2161	.0561	28.5099	.0628	-2.0185
.450	.11756	.24505	-.14166	1.4854	.3616	3.0260	.6551	1.8967	.8855	.6296	1.5151
.1689	.5698	1.8530	1.3153	.7335	.0509	2.2065	2.1556	.0532	28.4126	.0605	-2.0156
.500	.10485	.21956	-.11471	1.4826	.3583	2.5636	.7078	1.4847	.9136	.5688	1.4824
.2326	.5919	1.8385	1.3545	.8034	.0498	2.1576	2.1078	.0513	28.1727	.0540	-2.0086
.550	.09444	.19855	-.09465	1.4806	.3554	2.2387	.7477	1.1928	.9302	.5239	1.4541
.2794	.6059	1.8215	1.3772	.8463	.0487	2.1157	2.0670	.0495	27.9288	.0484	-2.0145
.600	.08578	.18102	-.07937	1.4793	.3531	2.0036	.7785	.9800	.9413	.4880	1.4293
.3171	.6155	1.8054	1.3925	.8757	.0477	2.0797	2.0320	.0478	27.6767	.0433	-2.0294
.625	.08196	.17343	-.07317	1.4794	.3523	1.9116	.7912	.8964	.9455	.4727	1.4182
.3334	.6190	1.7986	1.3988	.8871	.0474	2.0643	2.0169	.0471	27.5346	.0409	-2.0393
.650	.07845	.16631	-.06759	1.4793	.3516	1.8304	.8026	.8222	.9492	.4584	1.4075
.3487	.6222	1.7918	1.4042	.8970	.0471	2.0495	2.0024	.0464	27.4006	.0387	-2.0512
.675	.07519	.15983	-.06269	1.4798	.3511	1.7606	.8127	.7584	.9523	.4453	1.3976
.3628	.6248	1.7860	1.4092	.9056	.0468	2.0362	1.9894	.0457	27.2499	.0365	-2.0633
.700	.07217	.15364	-.05819	1.4800	.3504	1.6976	.8220	.7005	.9551	.4328	1.3879
.3763	.6272	1.7798	1.4136	.9133	.0466	2.0231	1.9765	.0450	27.1174	.0344	-2.0793
.725	.06936	.14807	-.05429	1.4811	.3503	1.6441	.8301	.6512	.9575	.4215	1.3790
.3887	.6289	1.7753	1.4181	.9199	.0465	2.0120	1.9655	.0444	26.9522	.0324	-2.0940
.750	.06673	.14291	-.05078	1.4825	.3503	1.5969	.8373	.6076	.9596	.4108	1.3704
.4004	.6302	1.7715	1.4225	.9258	.0464	2.0019	1.9555	.0439	26.7795	.0304	-2.1102
.775	.06428	.13784	-.04746	1.4833	.3500	1.5526	.8443	.5667	.9615	.4005	1.3620
.4119	.6318	1.7667	1.4262	.9313	.0463	1.9912	1.9449	.0433	26.6393	.0285	-2.1311
.800	.06197	.13307	-.04444	1.4841	.3498	1.5129	.8506	.5298	.9633	.3907	1.3539
.4229	.6331	1.7622	1.4296	.9362	.0461	1.9811	1.9350	.0426	26.4963	.0266	-2.1533
.825	.05981	.12885	-.04184	1.4865	.3503	1.4797	.8560	.4990	.9647	.3817	1.3464
.4330	.6335	1.7601	1.4340	.9405	.0463	1.9735	1.9272	.0422	26.3074	.0248	-2.1728
.850	.05777	.12475	-.03940	1.4885	.3507	1.4487	.8610	.4701	.9661	.3730	1.3390
.4429	.6340	1.7576	1.4380	.9444	.0463	1.9658	1.9194	.0417	26.1313	.0230	-2.1968
.875	.05585	.12084	-.03714	1.4906	.3511	1.4204	.8657	.4438	.9673	.3646	1.3319
.4525	.6343	1.7553	1.4418	.9481	.0464	1.9584	1.9119	.0412	25.9567	.0213	-2.2227
.900	.05403	.11751	-.03527	1.4950	.3526	1.3977	.8694	.4227	.9682	.3570	1.3252
.4612	.6334	1.7566	1.4474	.9512	.0469	1.9545	1.9075	.0409	25.7031	.0194	-2.2482

Table III

APPENDIXES A,B,C,D

Reaction	Δ	x	Page Number of Map
1. $^{208}\text{Pb}_{82} + ^{26}\text{Mg}_{12} = ^{234}\text{Pu}_{94}$	0.3098 \approx 0.3	0.7970 \approx 0.8	D-542
2. $^{208}\text{Pb}_{82} + ^{27}\text{Al}_{13} = ^{235}\text{Am}_{95}$	0.2977 \approx 0.3	0.8075 \approx 0.8	D-542
3. $^{208}\text{Pb}_{82} + ^{48}\text{Ca}_{20} = ^{256}\text{No}_{102}$	0.2309 \approx 0.225	0.8621 \approx 0.85-0.875	D-448, D-398
4. $^{208}\text{Pb}_{82} + ^{50}\text{Ti}_{22} = ^{258}\text{104}$	0.2158 \approx 0.225	0.8830 \approx 0.875	D-398
5. $^{208}\text{Pb}_{82} + ^{52}\text{Cr}_{24} = ^{260}\text{106}$	0.2020 \approx 0.2	0.8950 \approx 0.9	D-350
6. $^{208}\text{Pb}_{82} + ^{58}\text{Fe}_{26} = ^{266}\text{108}$	0.1891 \approx 0.2	0.9197 \approx 0.925	D-300
7. $^{208}\text{Pb}_{82} + ^{64}\text{Ni}_{28} = ^{272}\text{110}$	0.1772 \approx 0.175	0.9352 \approx 0.925	D-302
8. $^{209}\text{Bi}_{83} + ^{54}\text{Cr}_{24} = ^{263}\text{107}$	0.2039 \approx 0.2	0.9120 \approx 0.9-0.925	D-350, D-300
9. $^{248}\text{Cm}_{96} + ^{48}\text{Ca}_{20} = ^{296}\text{116}$	0.2556 \approx 0.25	0.9746 \approx 0.975	D-196
10. ($^{226}\text{Ra}_{88} + ^{41}\text{K}_{19} = ^{267}\text{107}$)	0.25	0.9	D-346

The remainder of this volume provides maps of the following seven quantities:

Scale Function on odd pages A-1 to A-49

Quadrupole Moment on even pages A-2 to A-50

Inertia Perpendicular on odd pages B-1 to B-49

Inertia Parallel on even pages B-2 to B-50

Coulomb Energy on odd pages C-1 to C-49

Surface Energy on even pages C-2 to C-50

Deformation Energy:

for x = 0.050 to x = 0.725 on odd pages D-1 to D-665

for x = 1.500 to x = 0.750 on even pages D-2 to D-664

SCALE ASYMMETRY DELTA=0.

SPHERE 2.00000 TANGENT 1.58740 SPACING .010

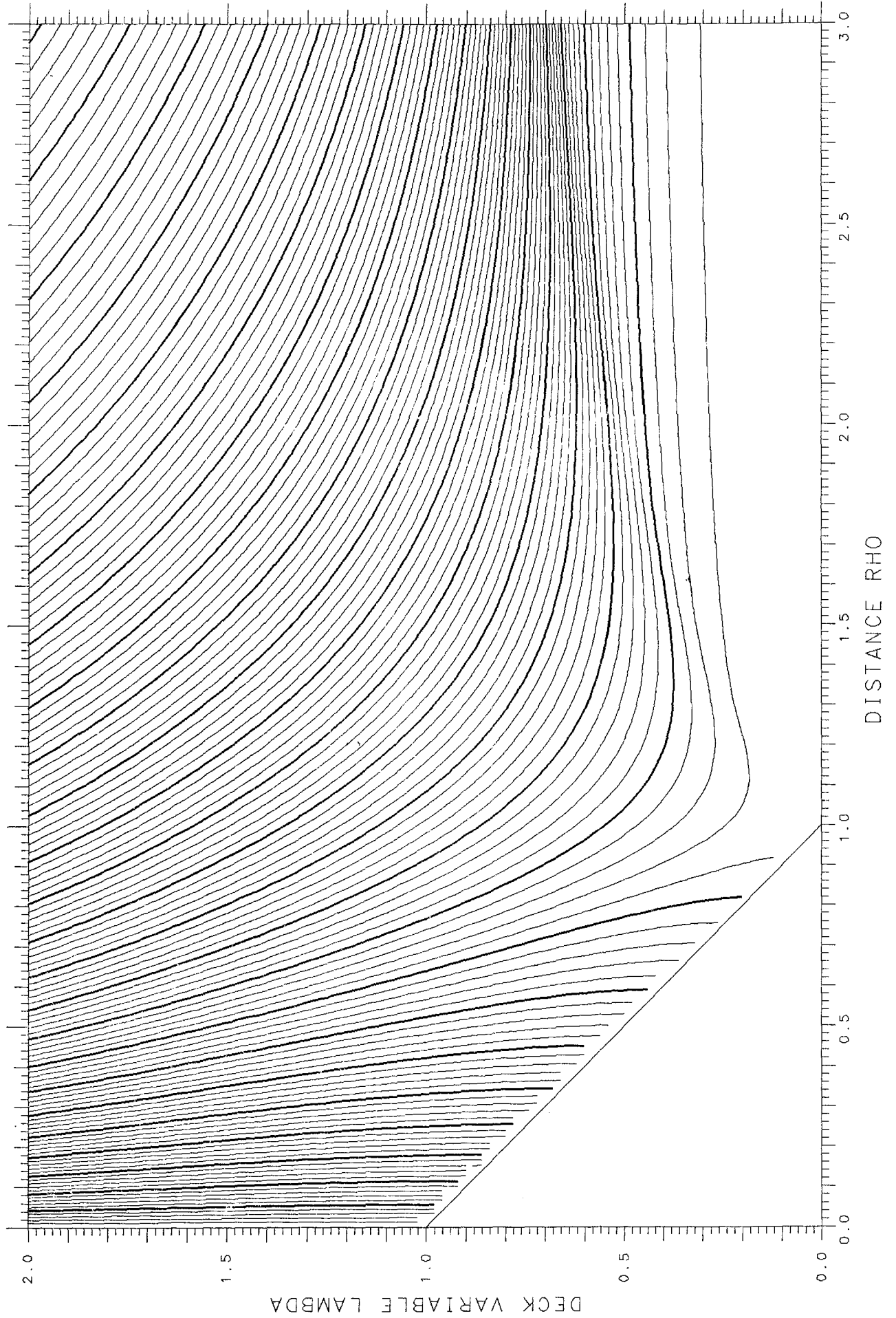

QUADRUPOLE MOMENT ASYMMETRY DELTA= .600

TANGENT .04685 SPACING .05

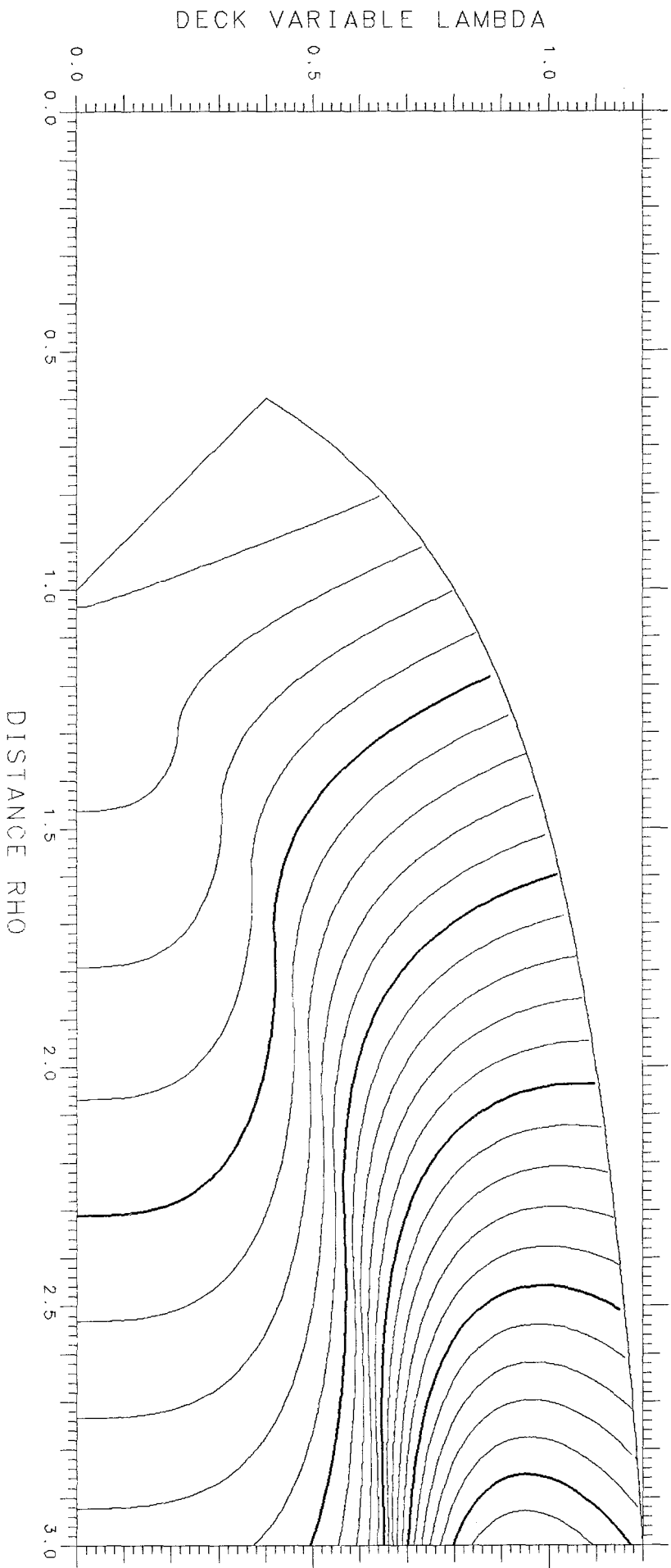

SCALE ASYMMETRY DELTA= .025

SPHERE 1.95122 TANGENT 1.58641 SPACING .010

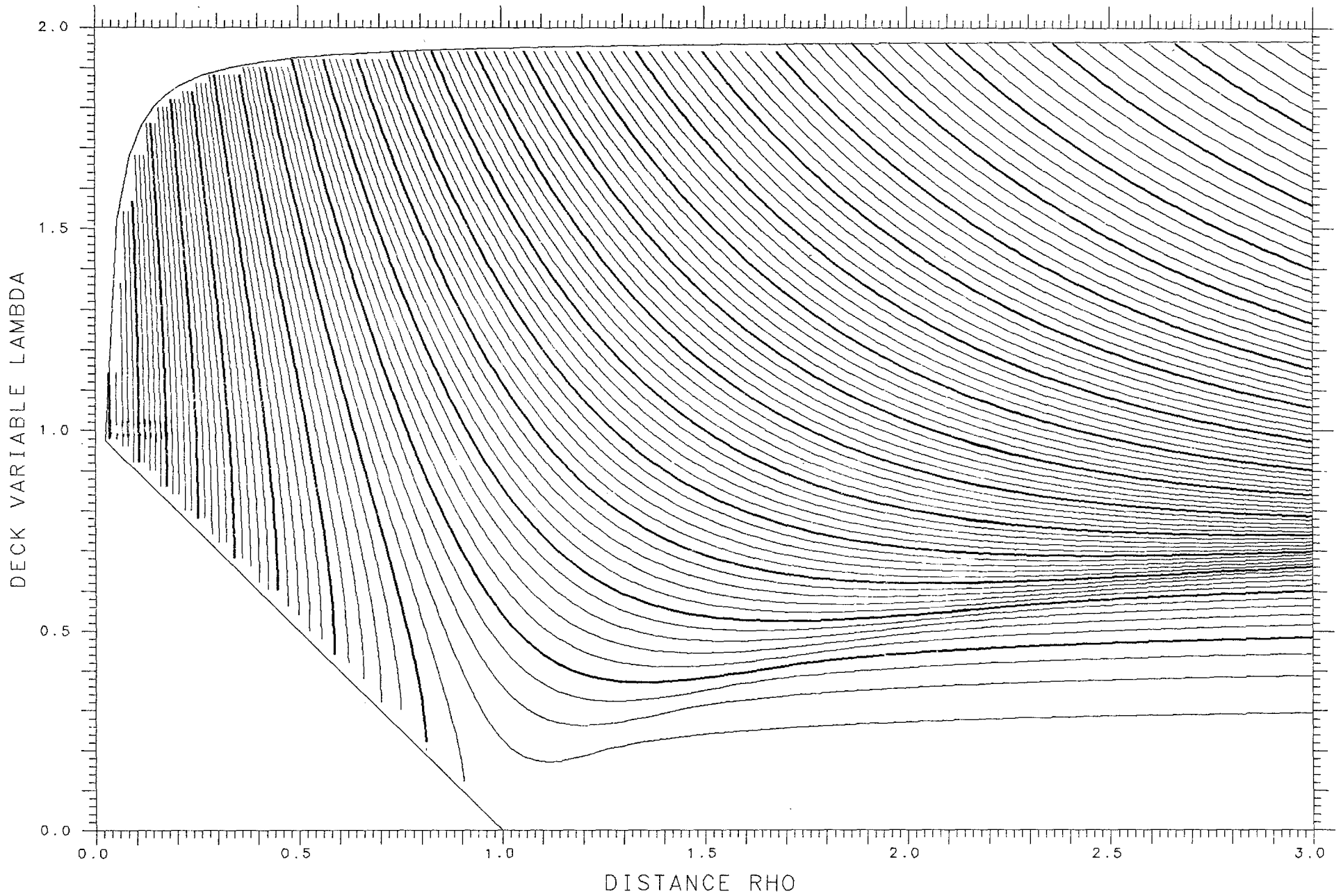

QUADRUPOLE MOMENT ASYMMETRY DELTA= .575

TANGENT .06016 SPACING .05

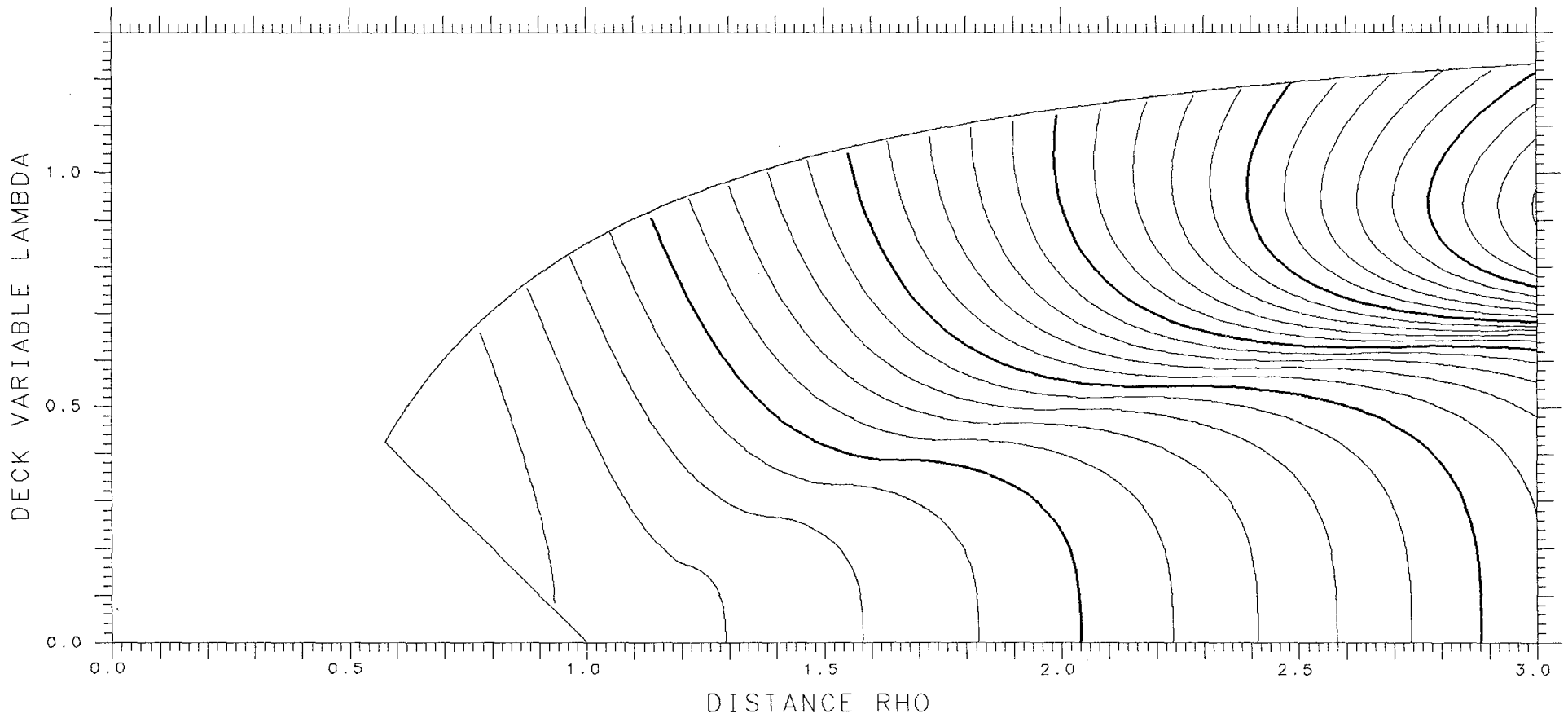

SCALE ASYMMETRY DELTA= .050

SPHERE 1.90476 TANGENT 1.58345 SPACING .010

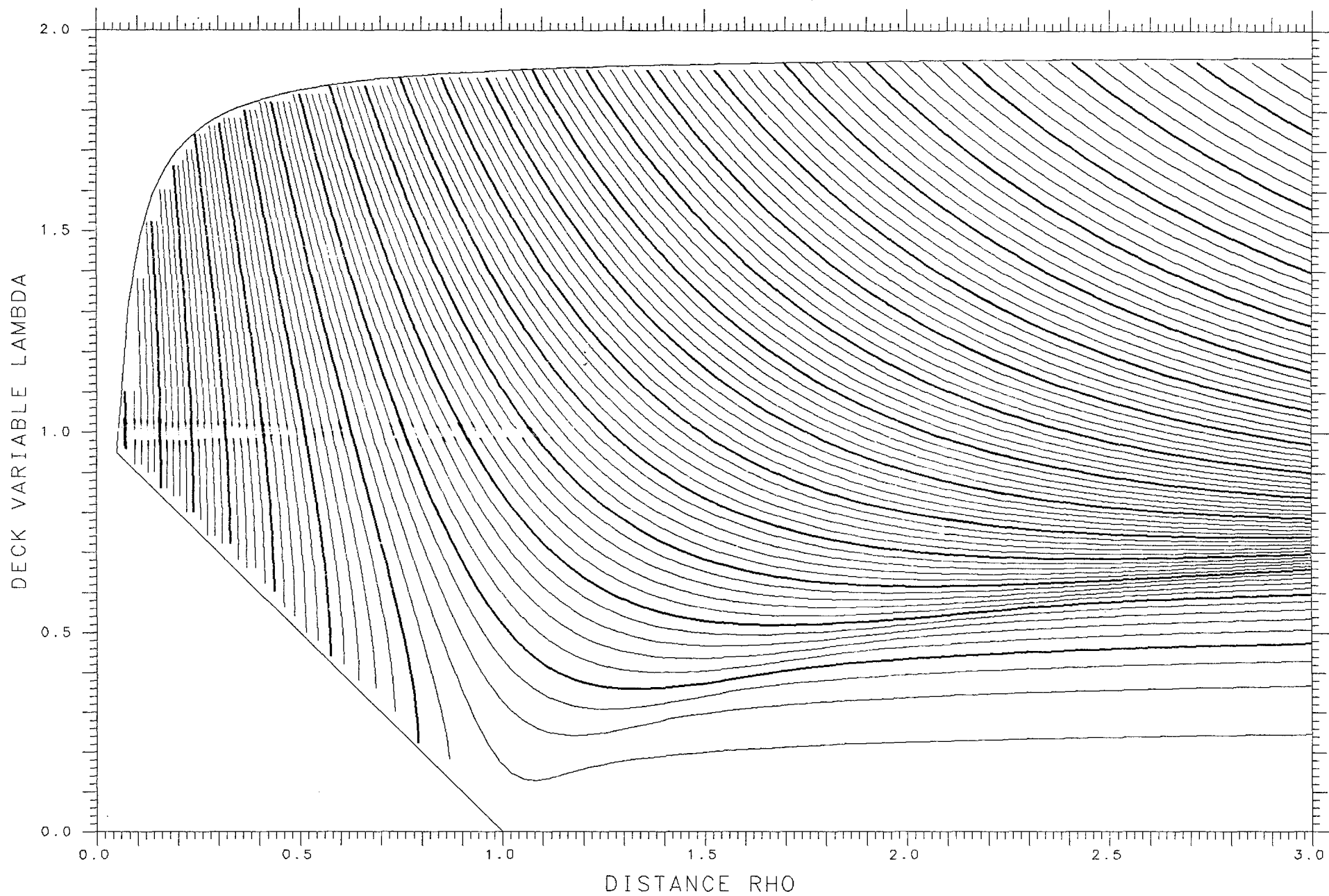

QUADRUPOLE MOMENT ASYMMETRY DELTA= .550

TANGENT .07640 SPACING .05

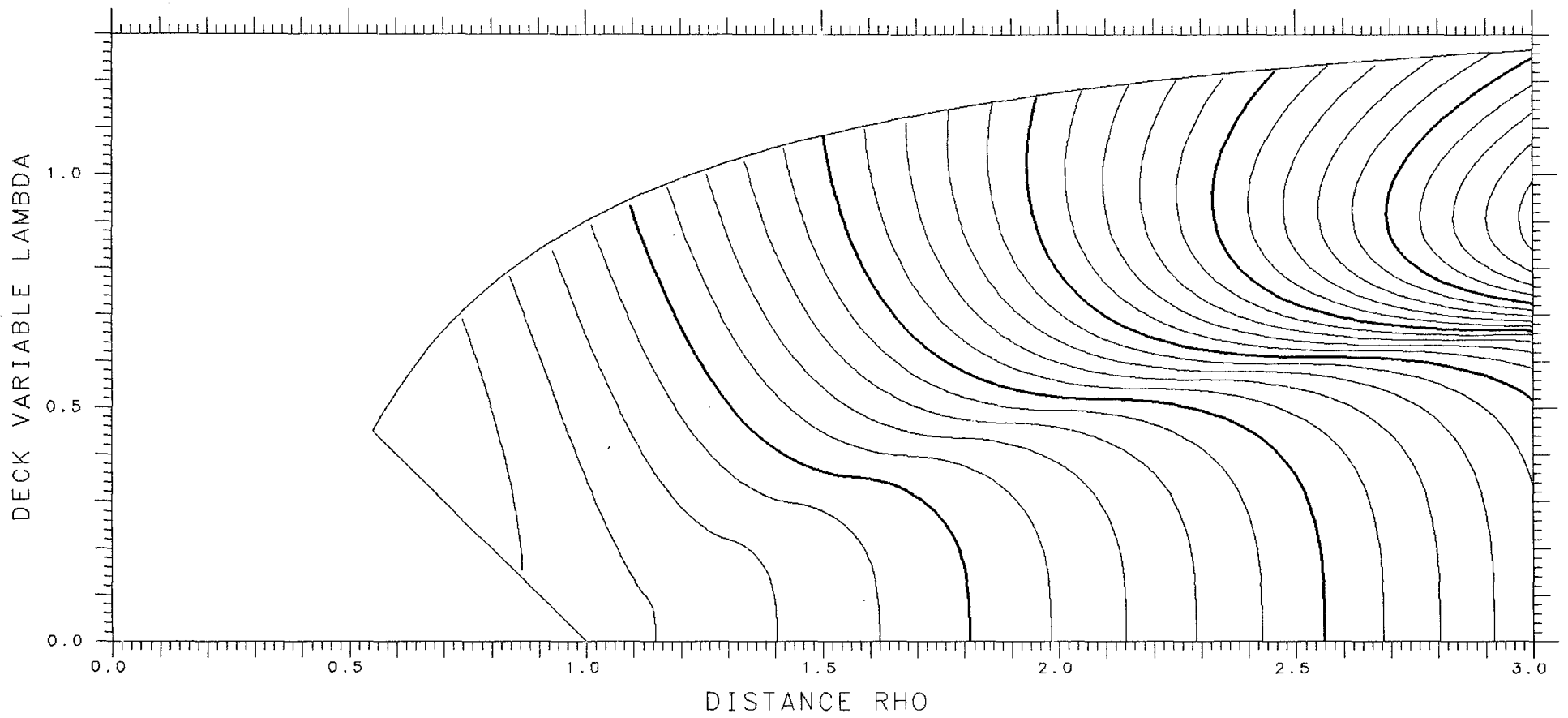

SCALE ASYMMETRY DELTA= .075

SPHERE 1.86047 TANGENT 1.57857 SPACING .010

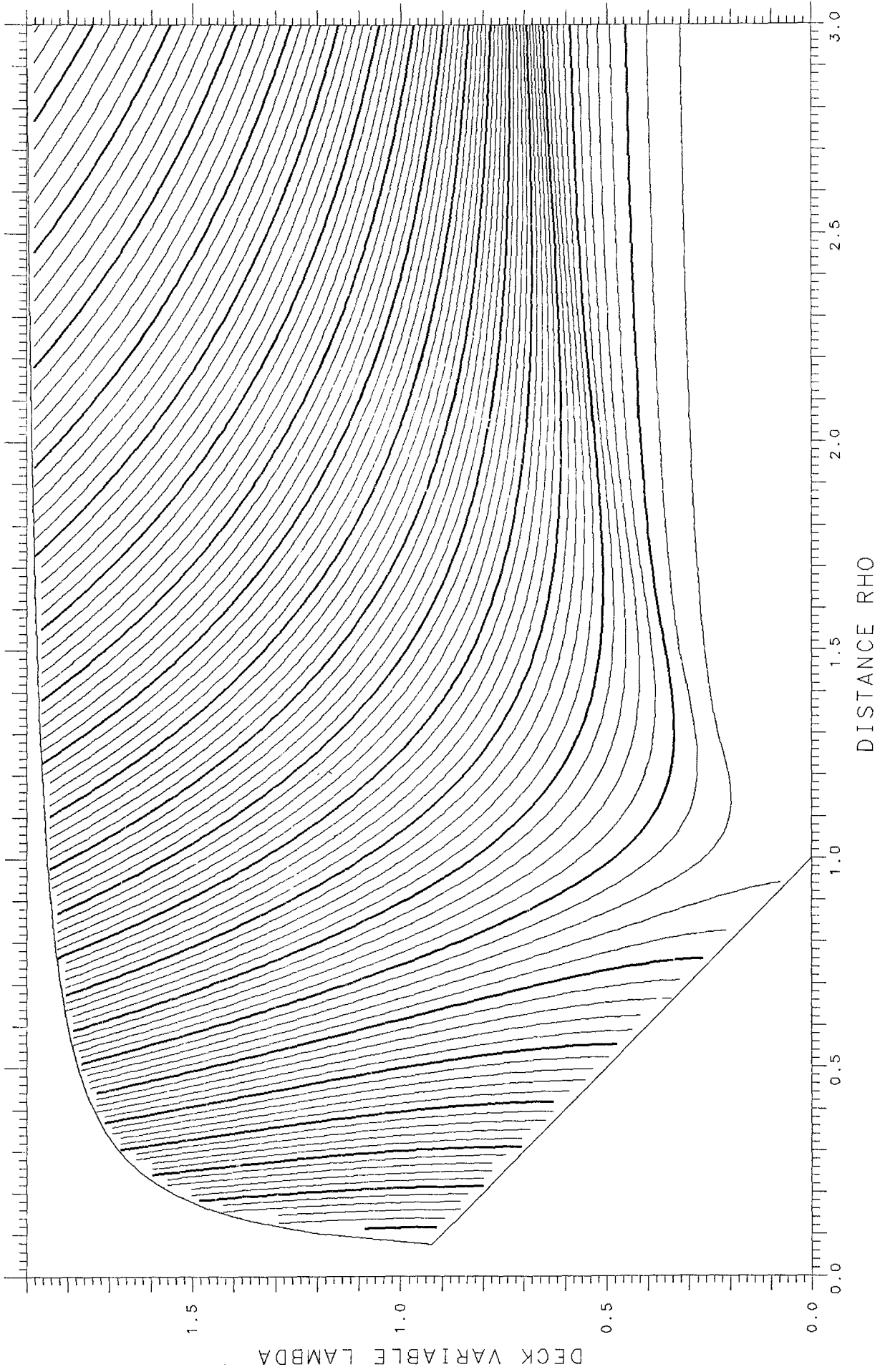

QUADRUPOLE MOMENT ASYMMETRY DELTA= .525

TANGENT .09602 SPACING .05

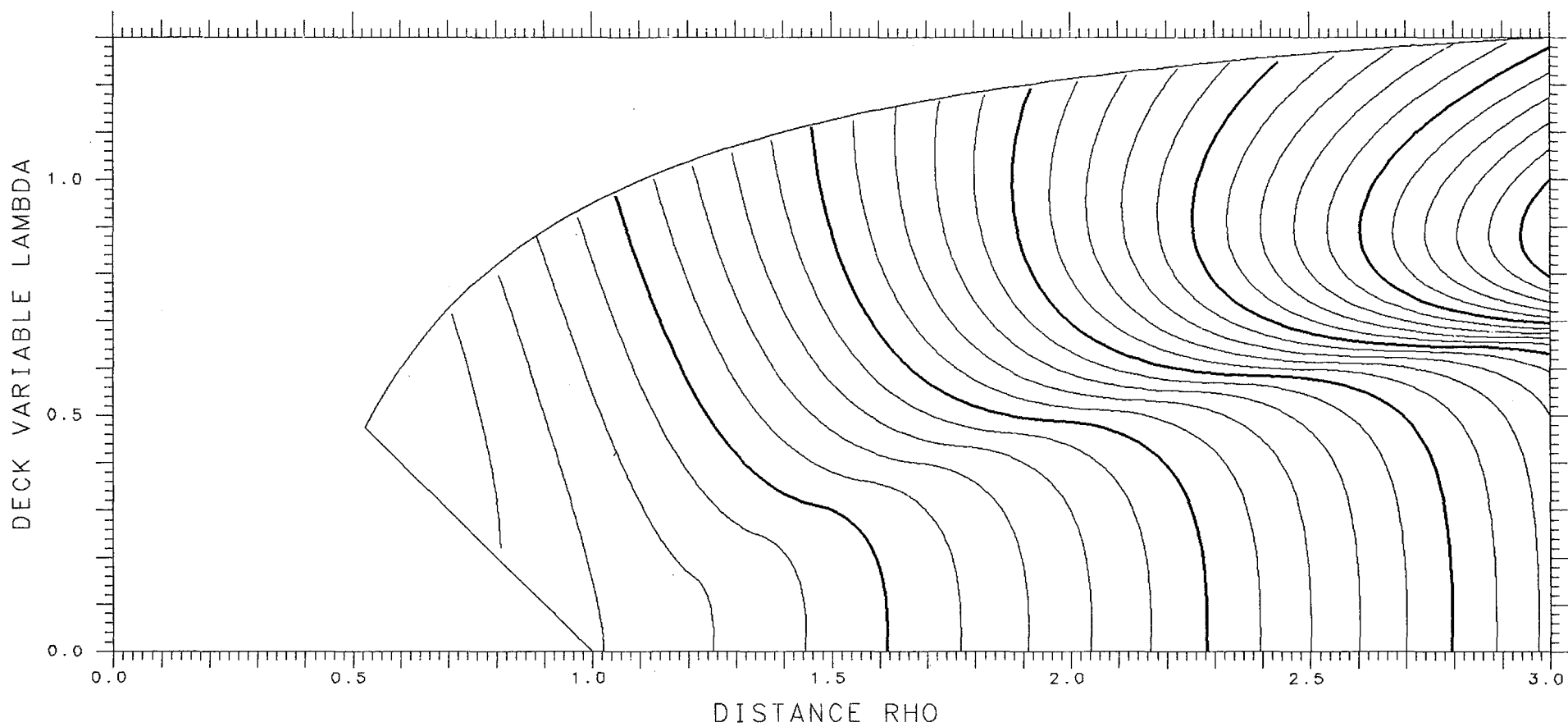

SCALE ASYMMETRY DELTA= .100
SPHERE 1.81818 TANGENT 1.57184 SPACING .010

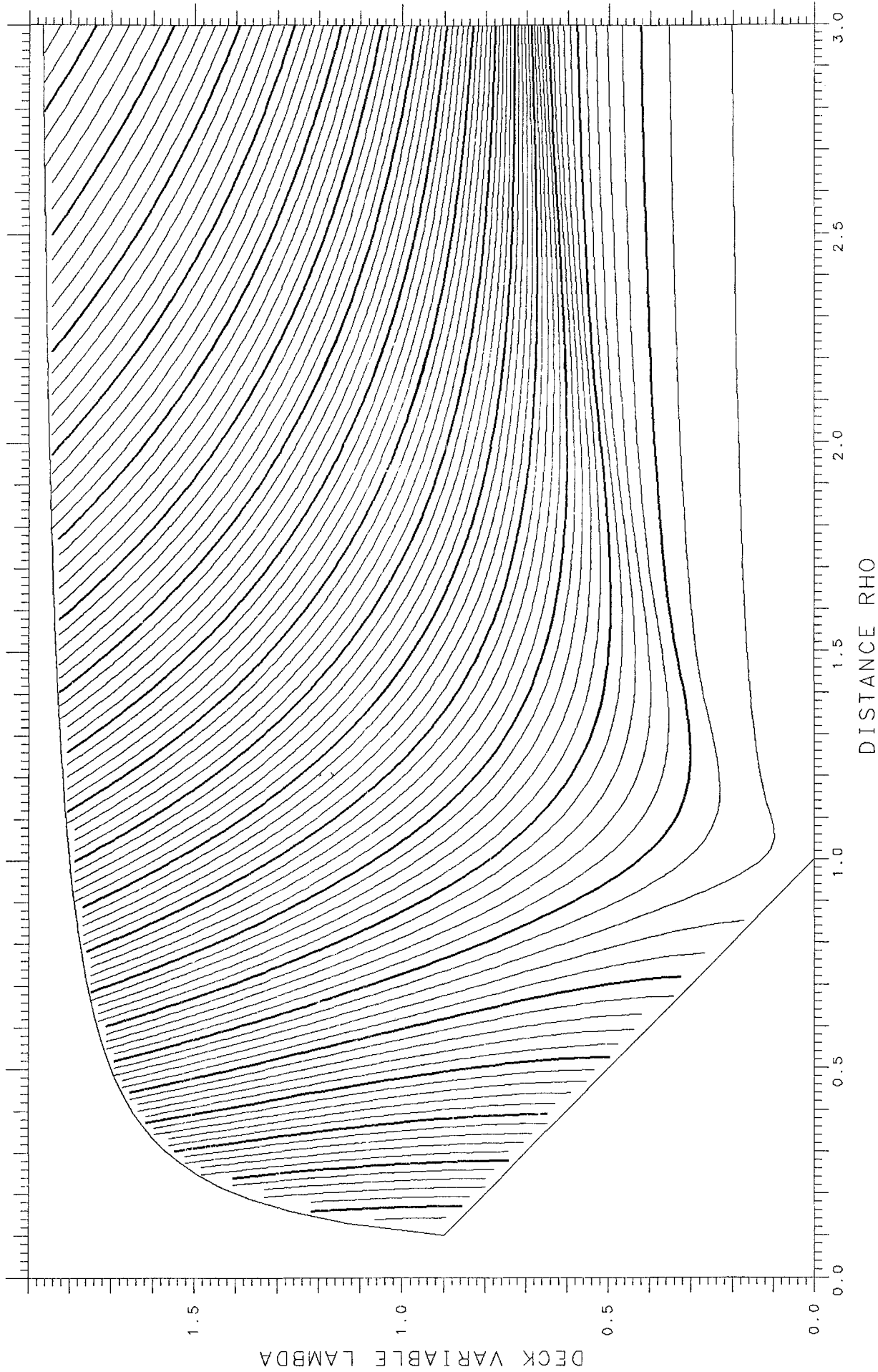

QUADRUPOLE MOMENT ASYMMETRY DELTA = .500

TANGENT .11952 SPACING .05

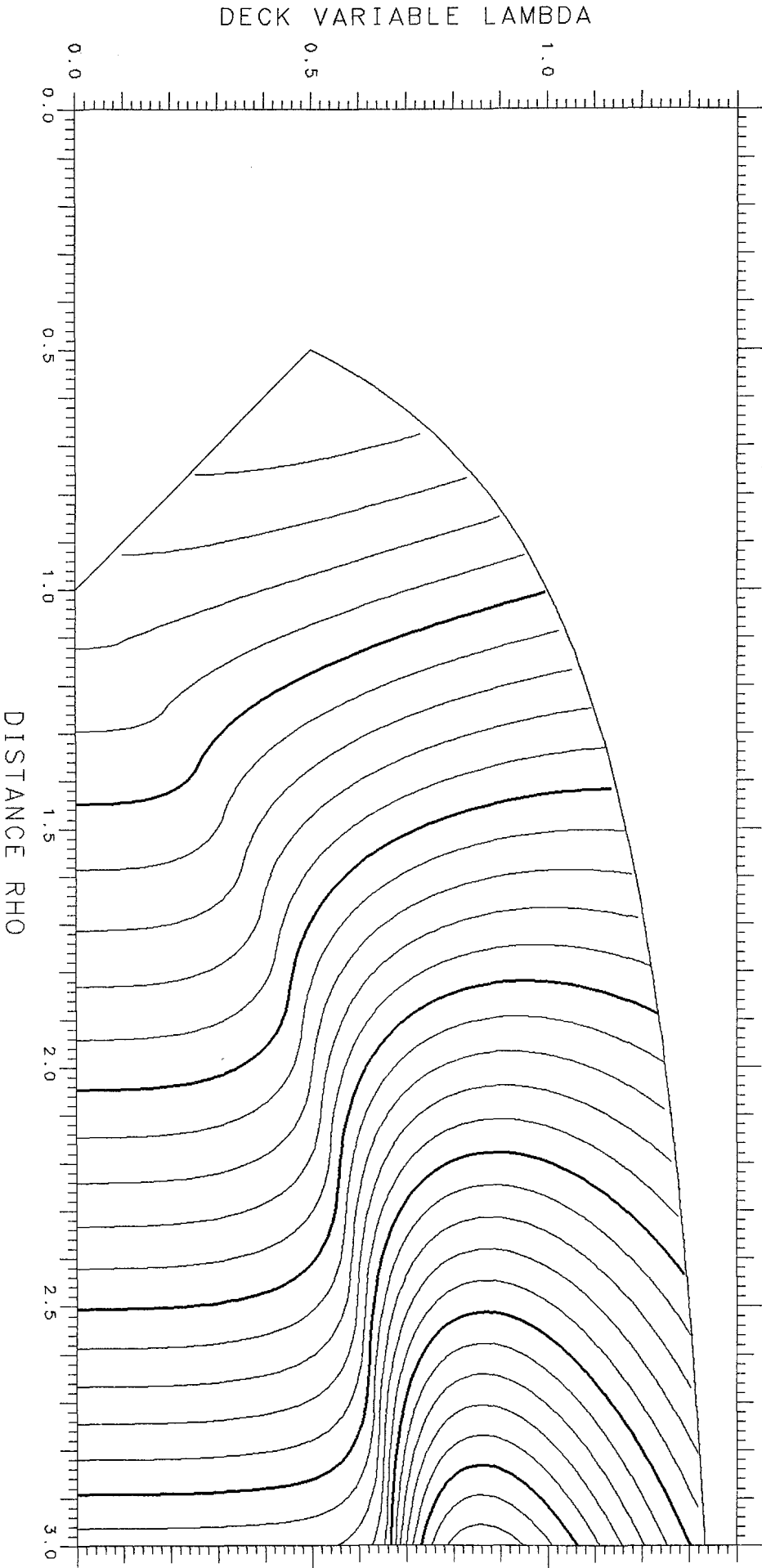

SCALE ASYMMETRY DELTA= .125
SPHERE 1.77778 TANGENT 1.56335 SPACING .010

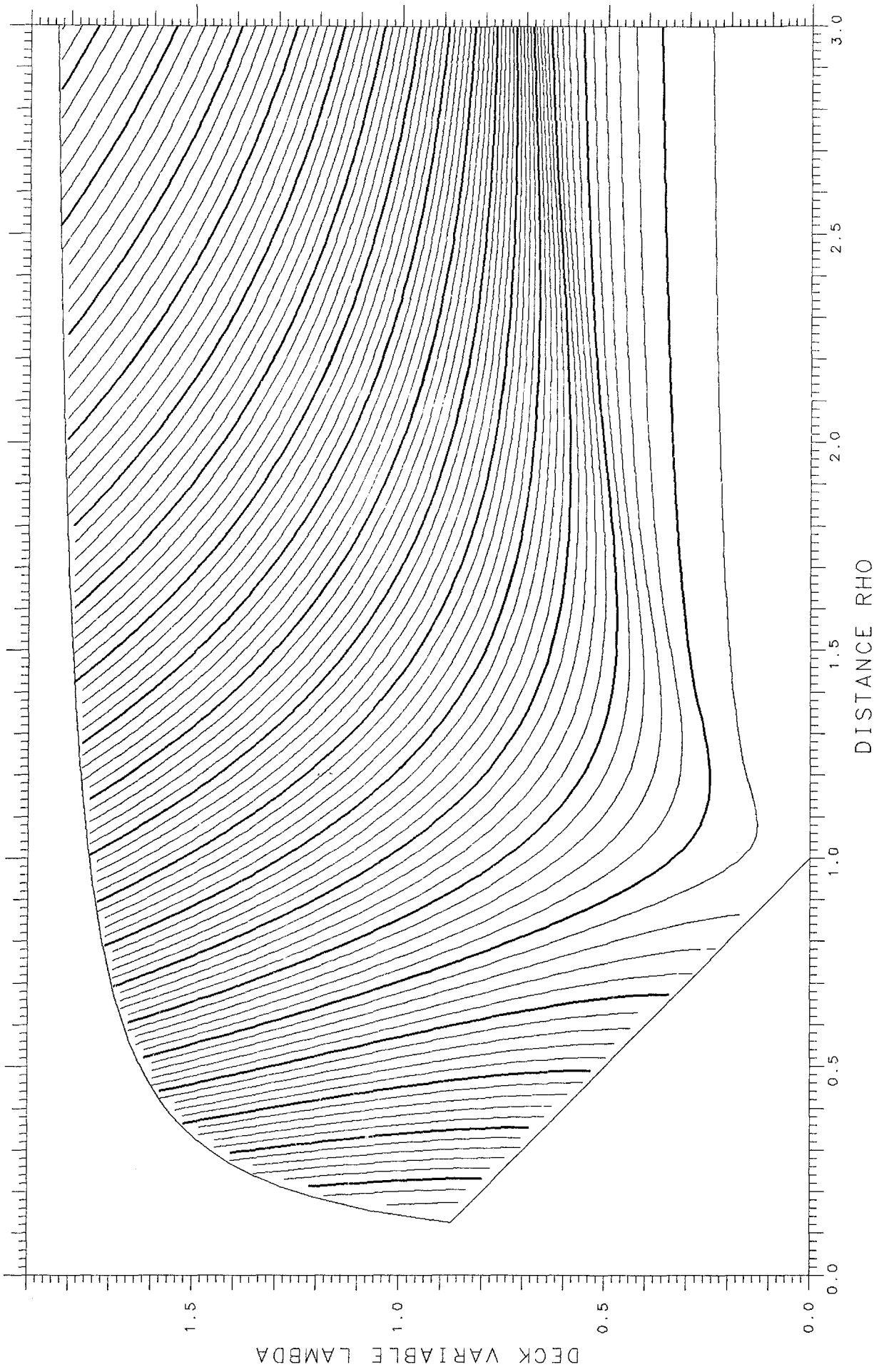

QUADRUPOLE MOMENT ASYMMETRY DELTA= .475

TANGENT .14741 SPACING .05

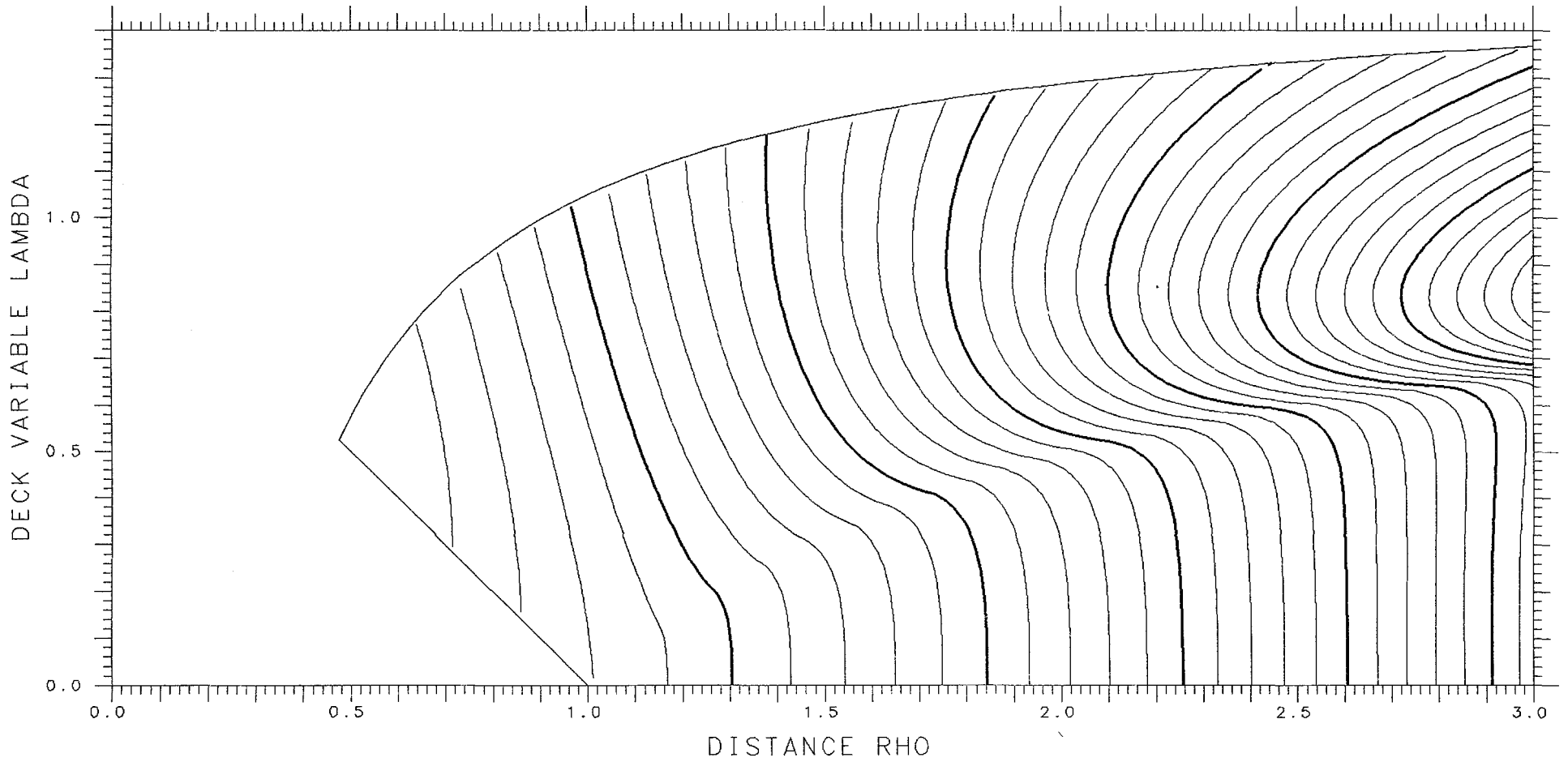

SCALE ASYMMETRY DELTA = .150
SPHERE 1.73913 TANGENT 1.55321 SPACING .010

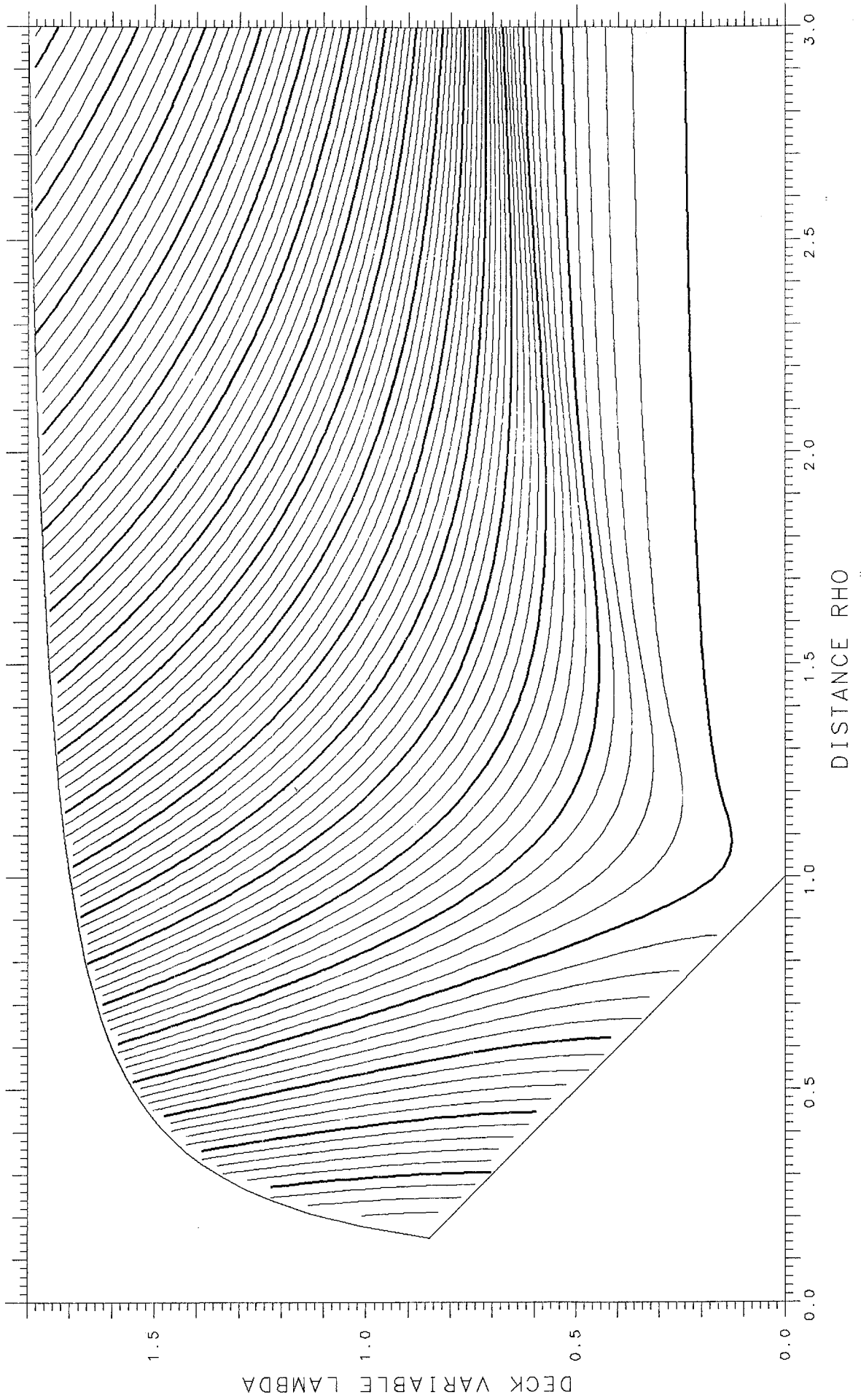

QUADRUPOLE MOMENT ASYMMETRY DELTA= .450

TANGENT .18022 SPACING .05

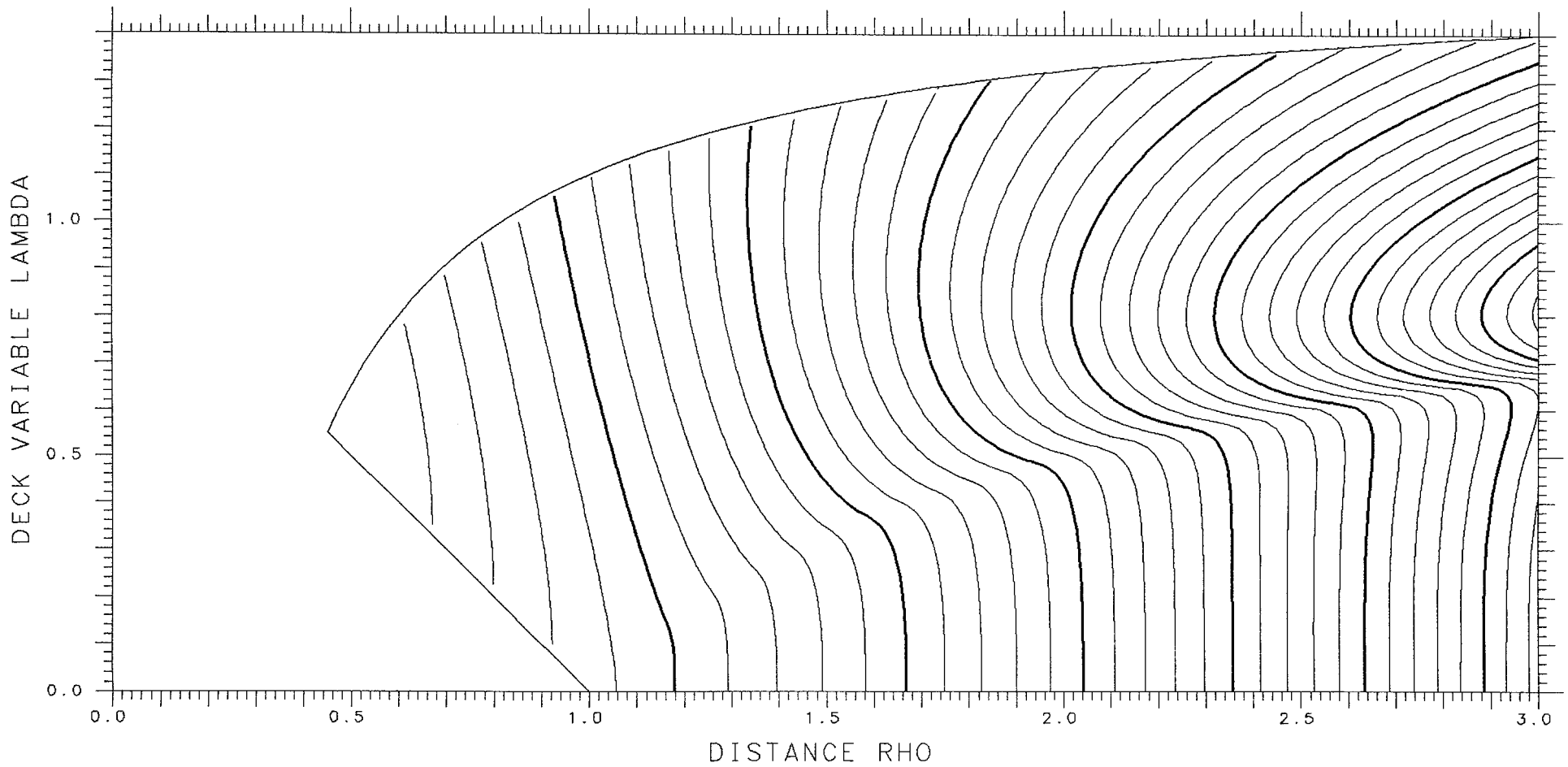

SCALE ASYMMETRY DELTA= .175
SPHERE 1.70213 TANGENT 1.54157 SPACING .010

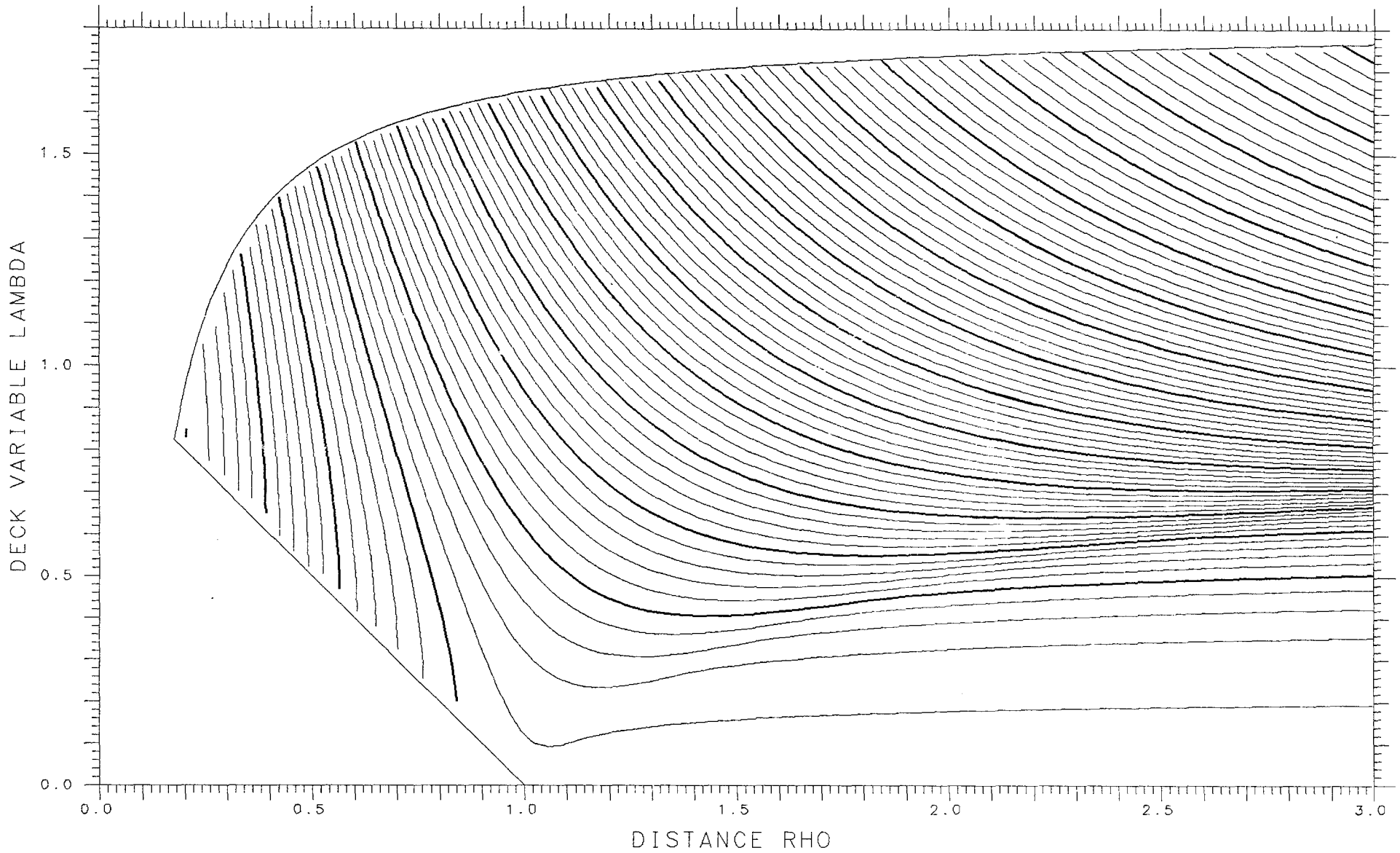

QUADRUPOLE MOMENT ASYMMETRY DELTA= .425

TANGENT .21844 SPACING .05

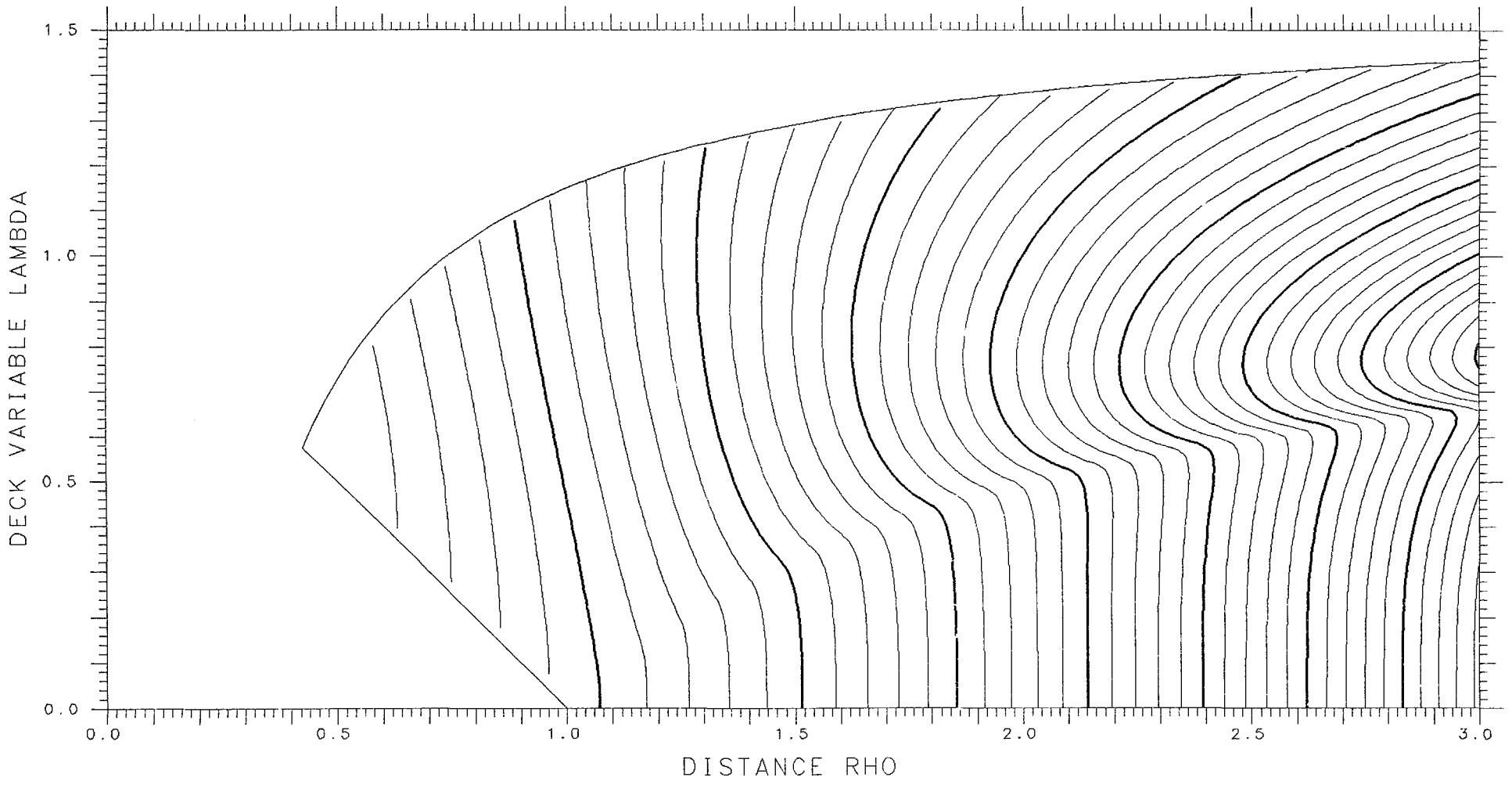

SCALE ASYMMETRY DELTA= .200

SPHERE 1.66667 TANGENT 1.52855 SPACING .010

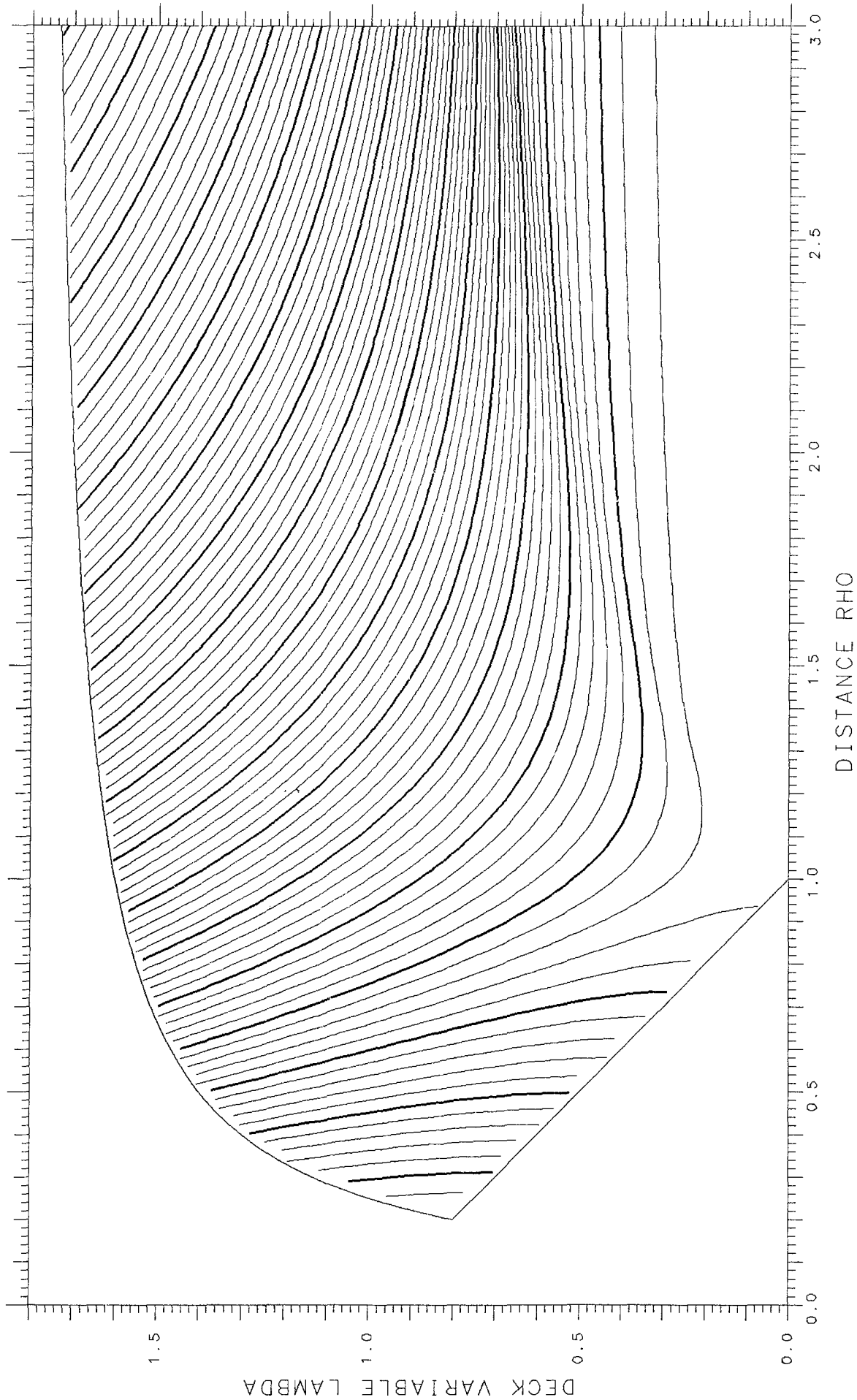

QUADRUPOLE MOMENT ASYMMETRY DELTA = .400

TANGENT .26251 SPACING .05

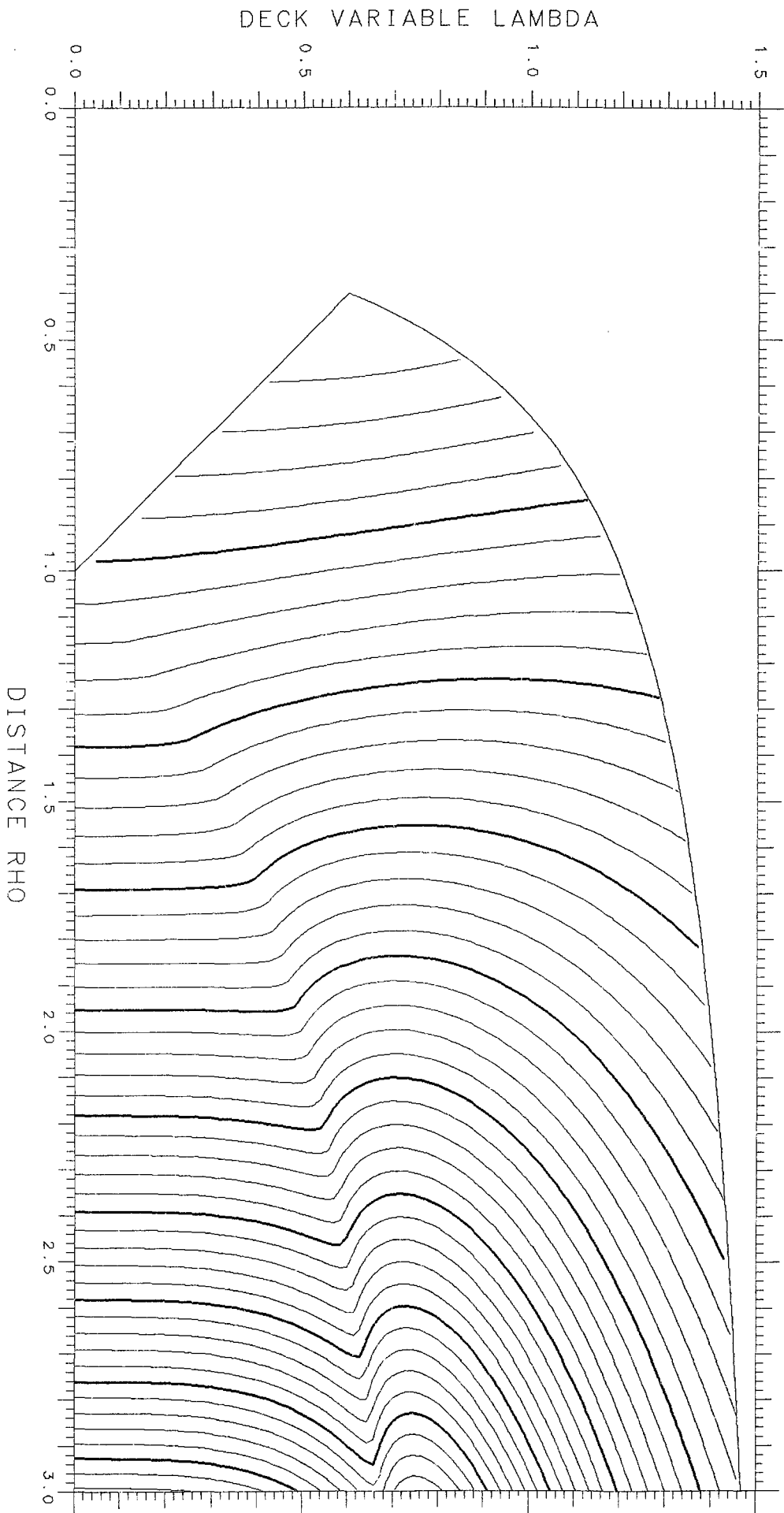

SCALE ASYMMETRY DELTA= .225

SPHERE 1.63265 TANGENT 1.51432 SPACING .010

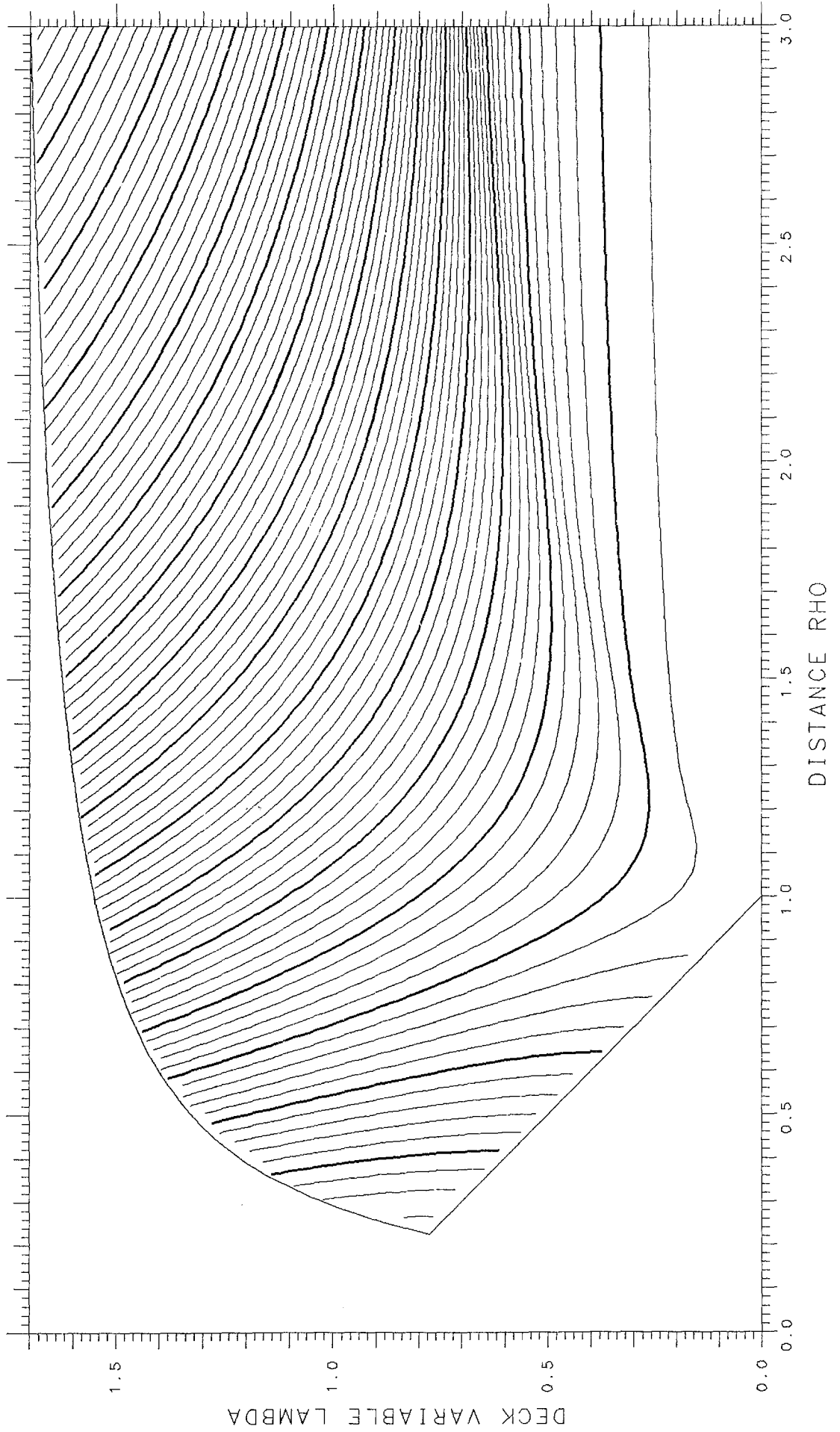

QUADRUPOLE MOMENT ASYMMETRY DELTA= .375

TANGENT .31280 SPACING .05

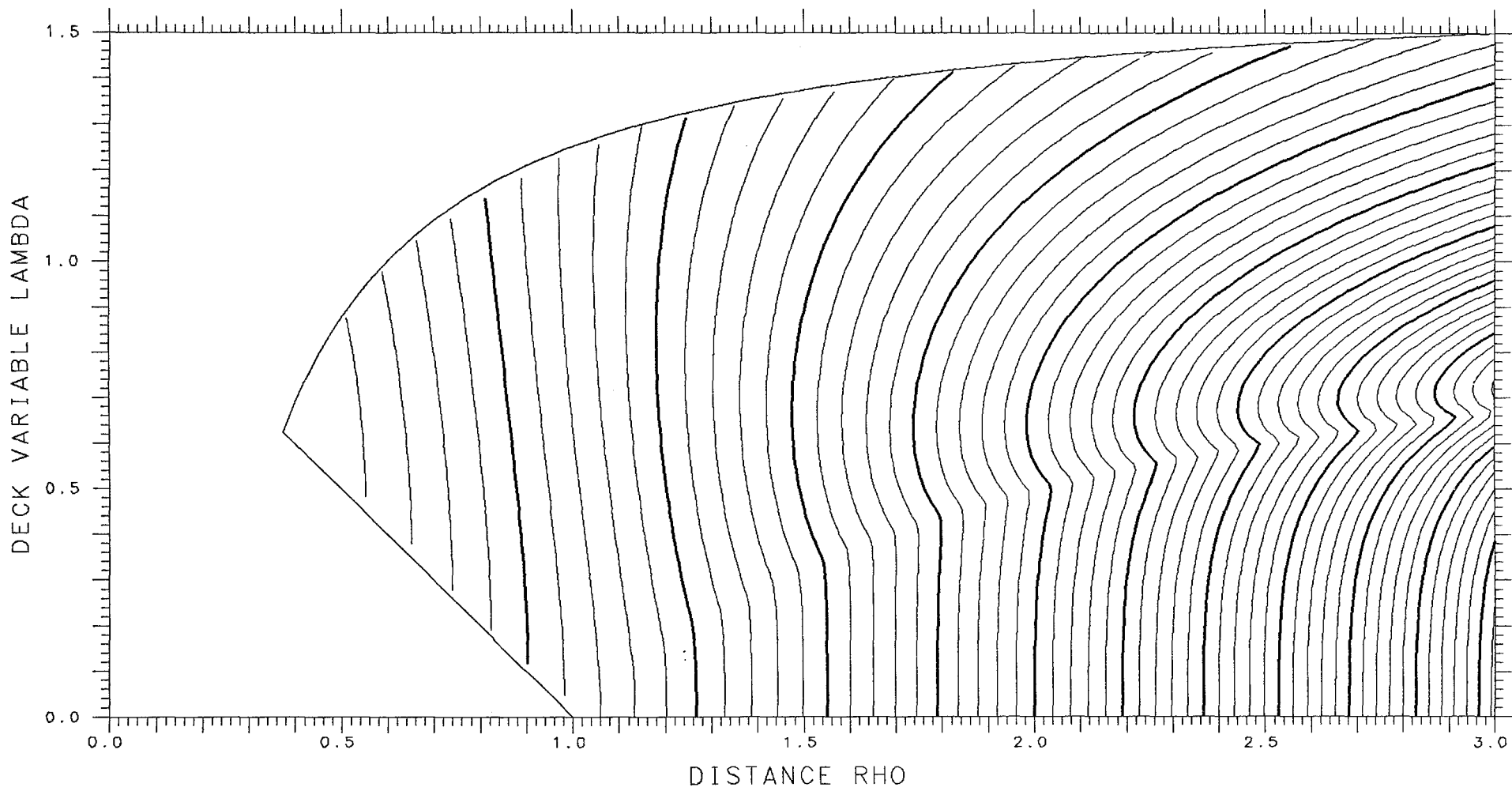

SCALE ASYMMETRY DELTA= .250

SPHERE 1.60000 TANGENT 1.49902 SPACING .010

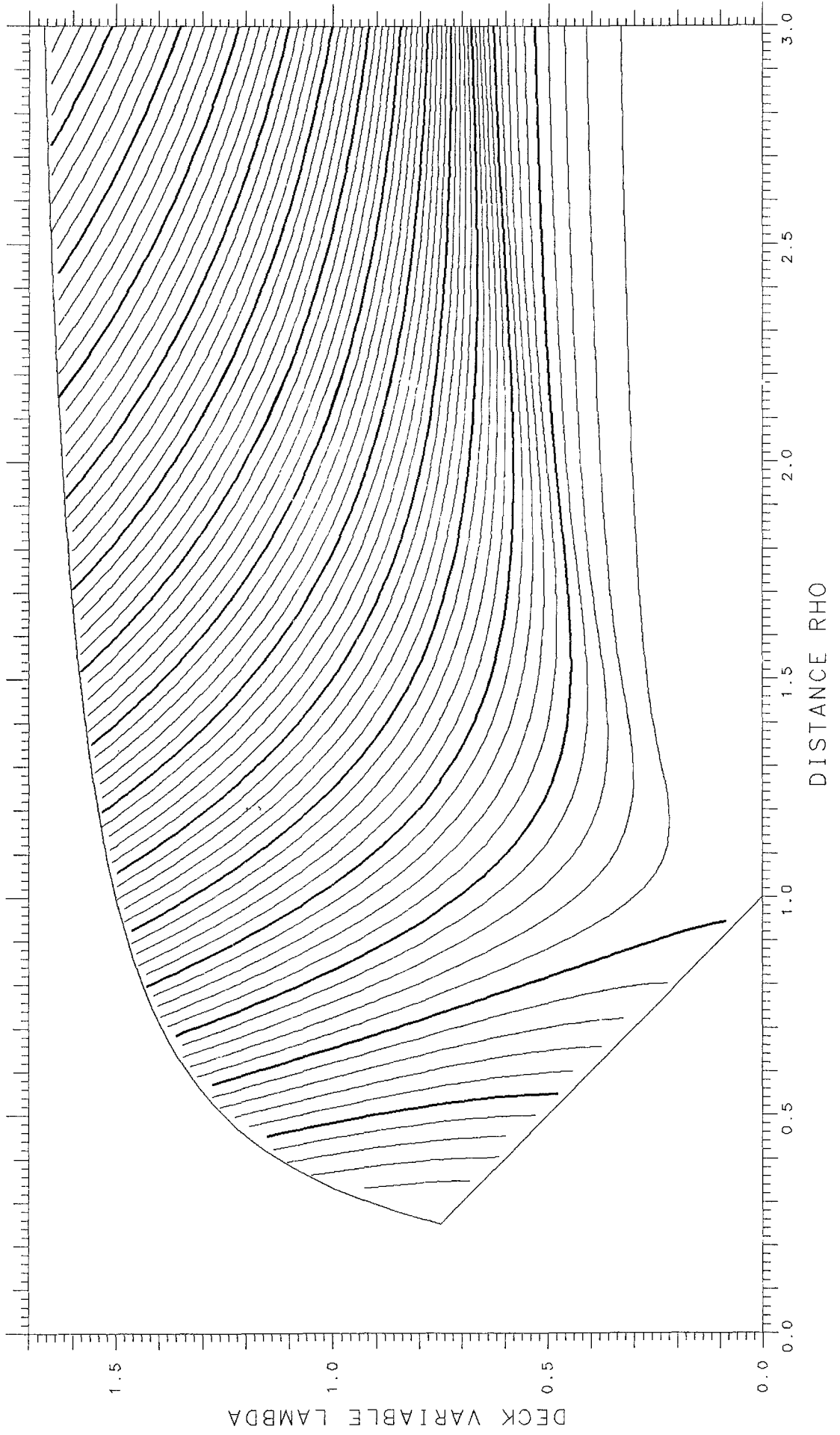

QUADRUPOLE MOMENT ASYMMETRY DELTA= .350

TANGENT .36950 SPACING .05

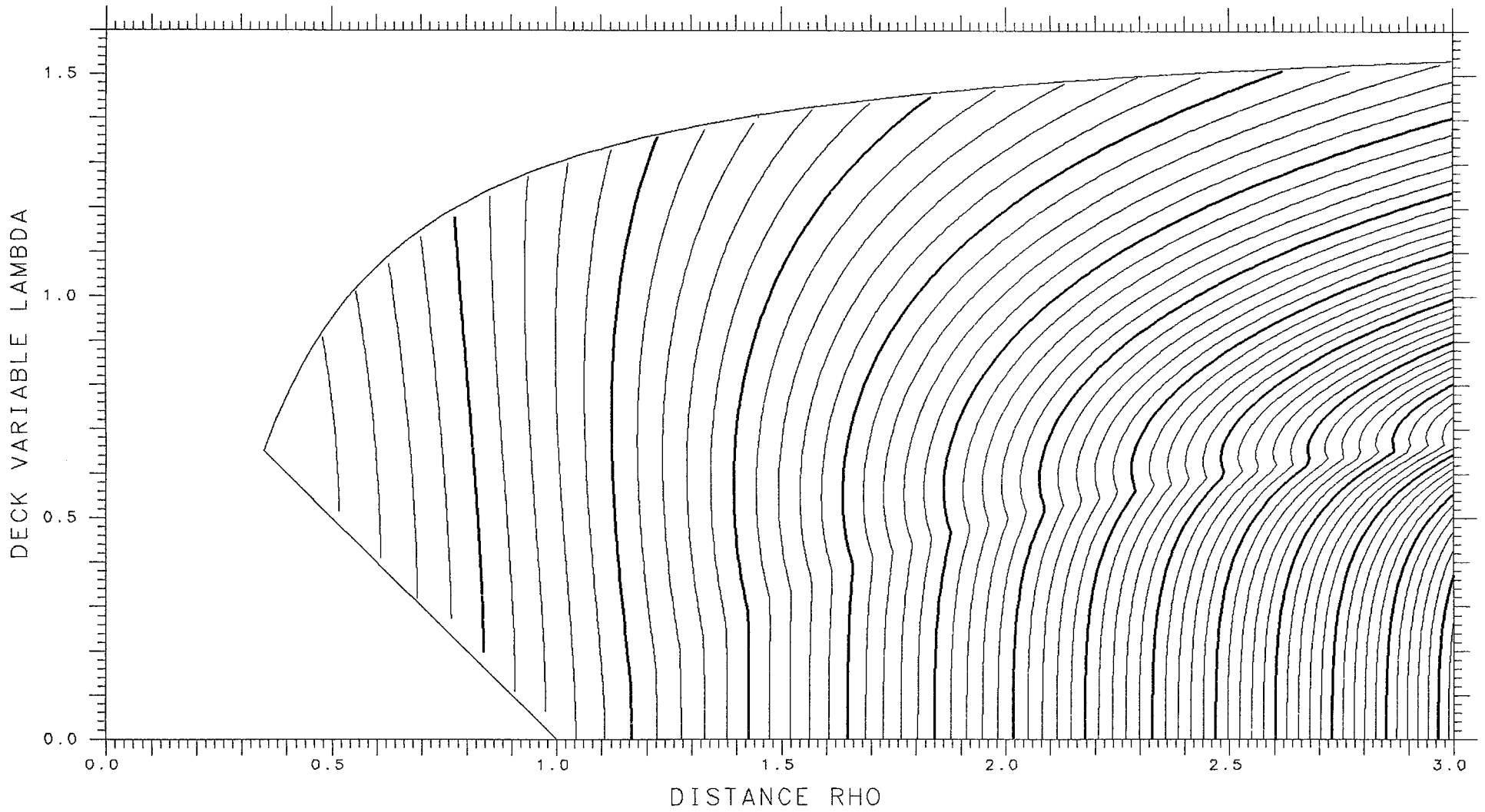

SCALE ASYMMETRY DELTA= .275

SPHERE 1.56863 TANGENT 1.48281 SPACING .010

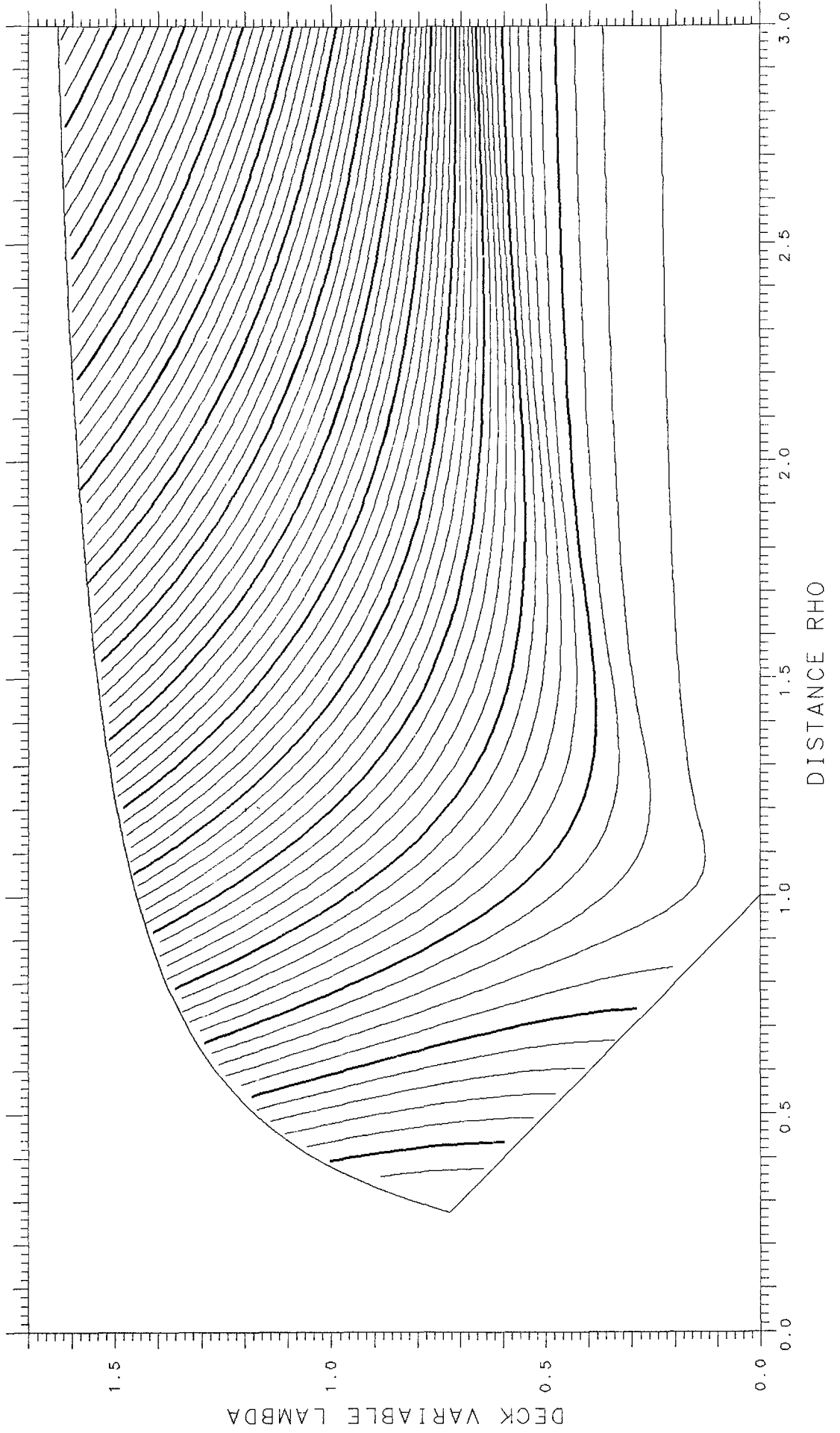

QUADRUPOLE MOMENT ASYMMETRY DELTA= .325

TANGENT .43263 SPACING .05

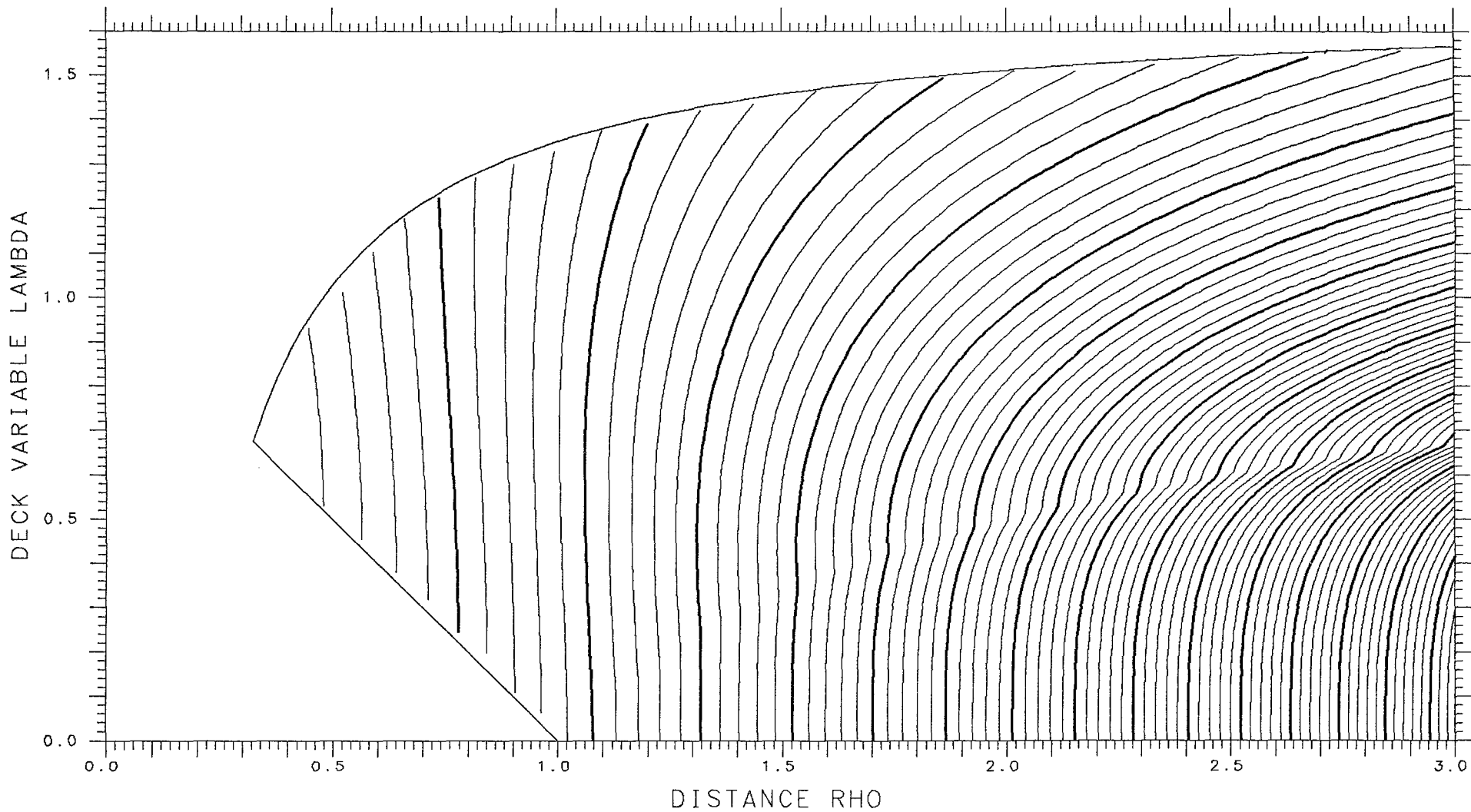

SCALE ASYMMETRY DELTA= .300

SPHERE 1.53846 TANGENT 1.46584 SPACING .010

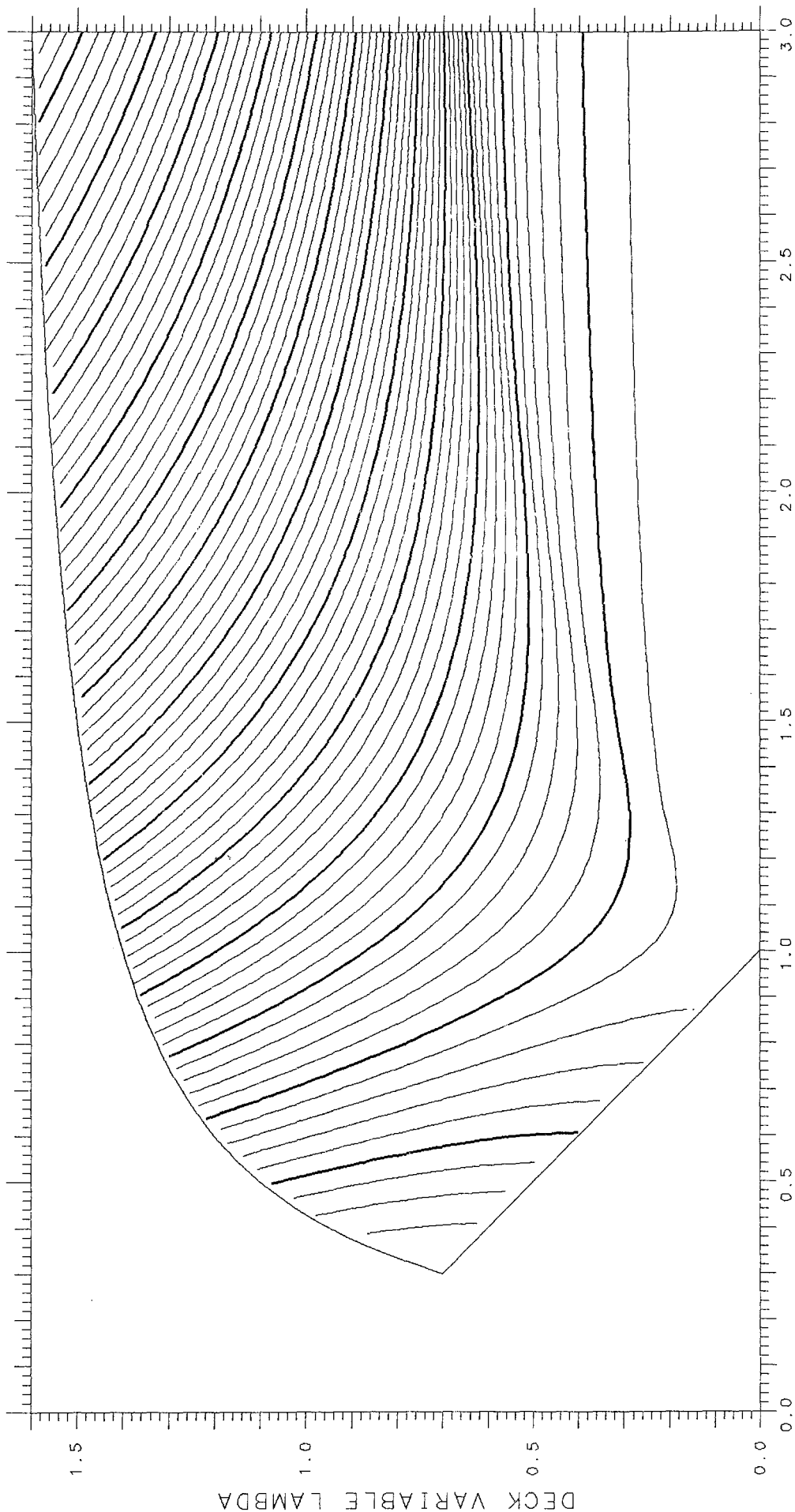

DISTANCE RHO

QUADRUPOLE MOMENT ASYMMETRY DELTA= .300

TANGENT .50195 SPACING .05

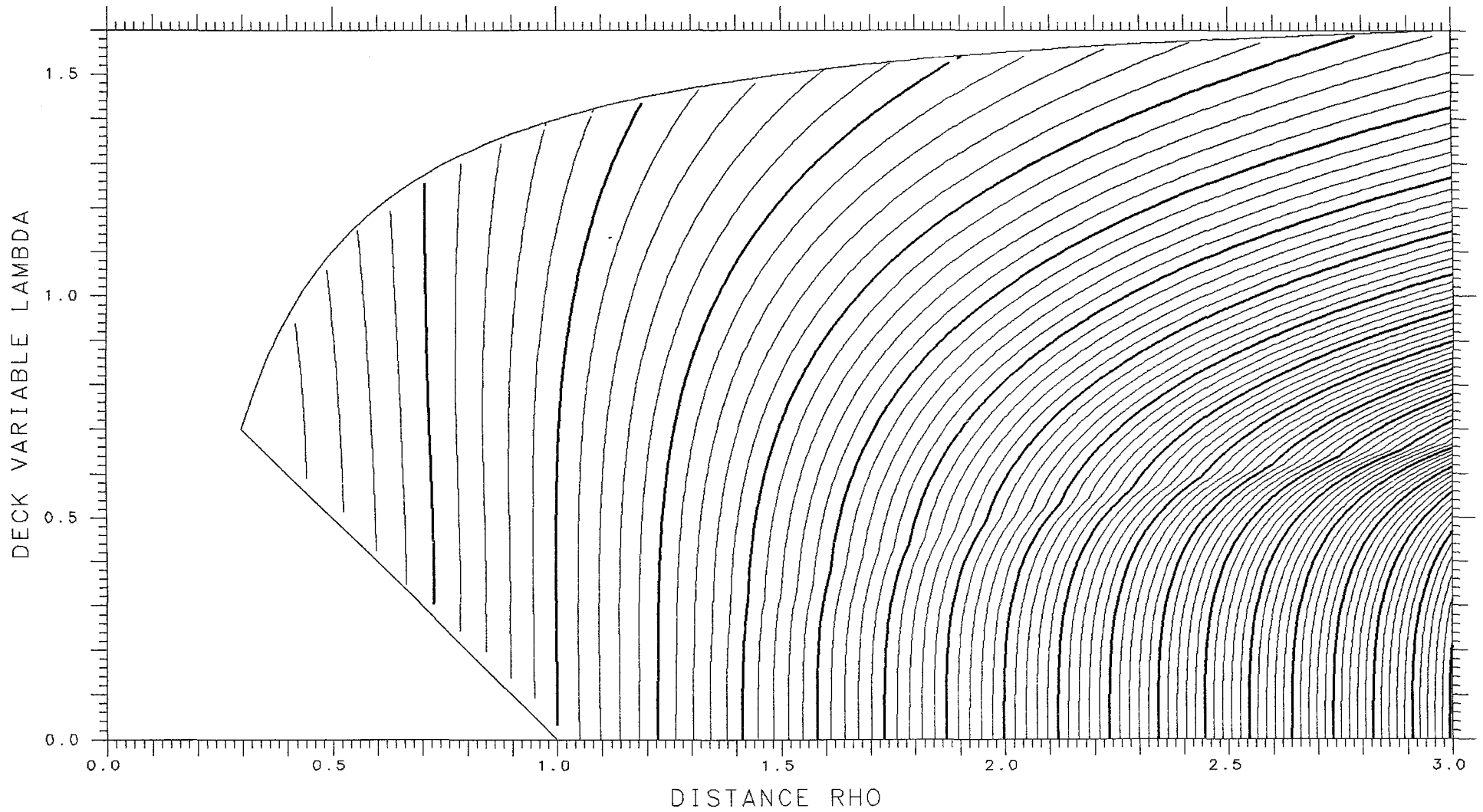

SCALE ASYMMETRY DELTA= .325

SPHERE 1.50943 TANGENT 1.44823 SPACING .010

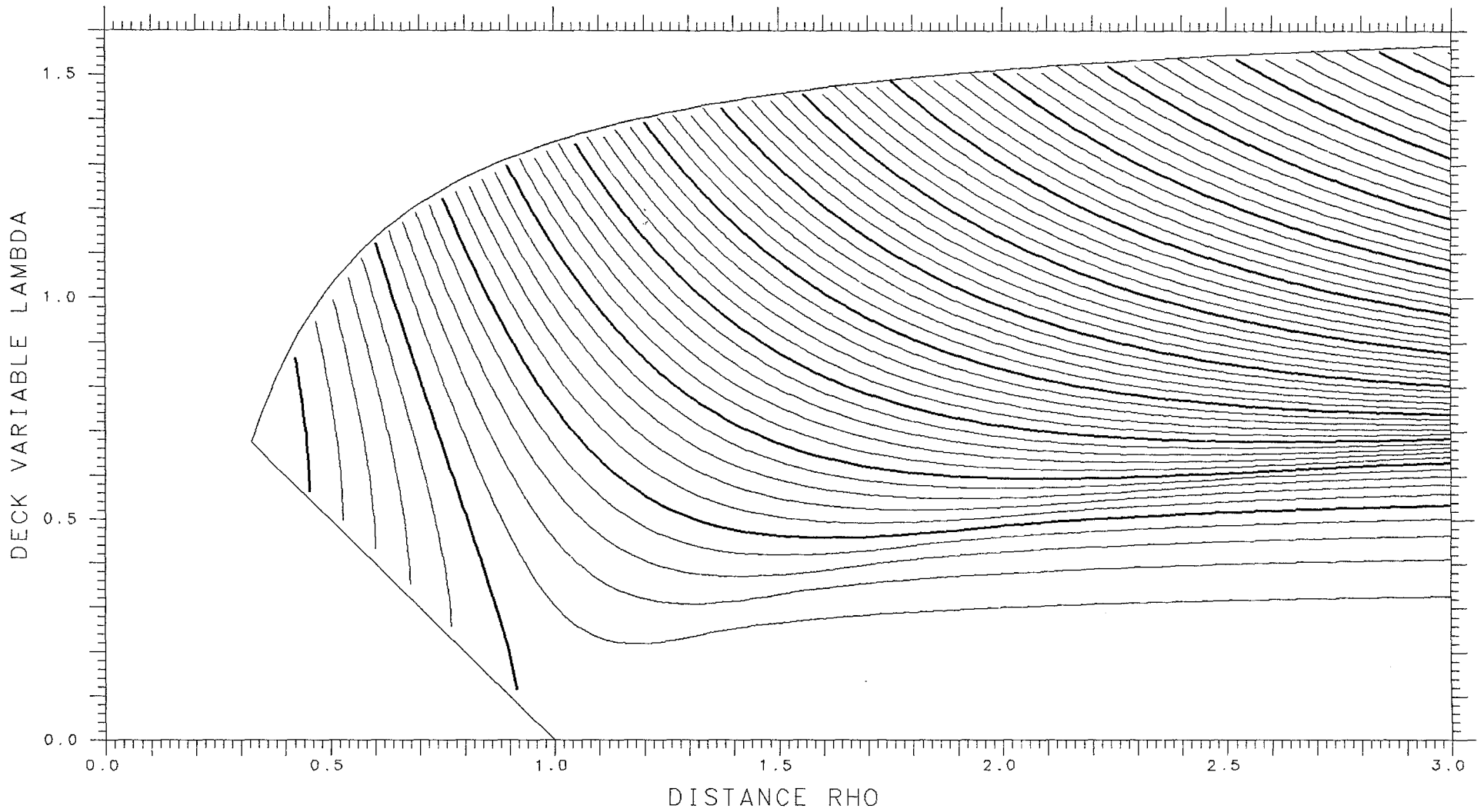

QUADRUPOLE MOMENT ASYMMETRY DELTA= .275

TANGENT .57688 SPACING .10

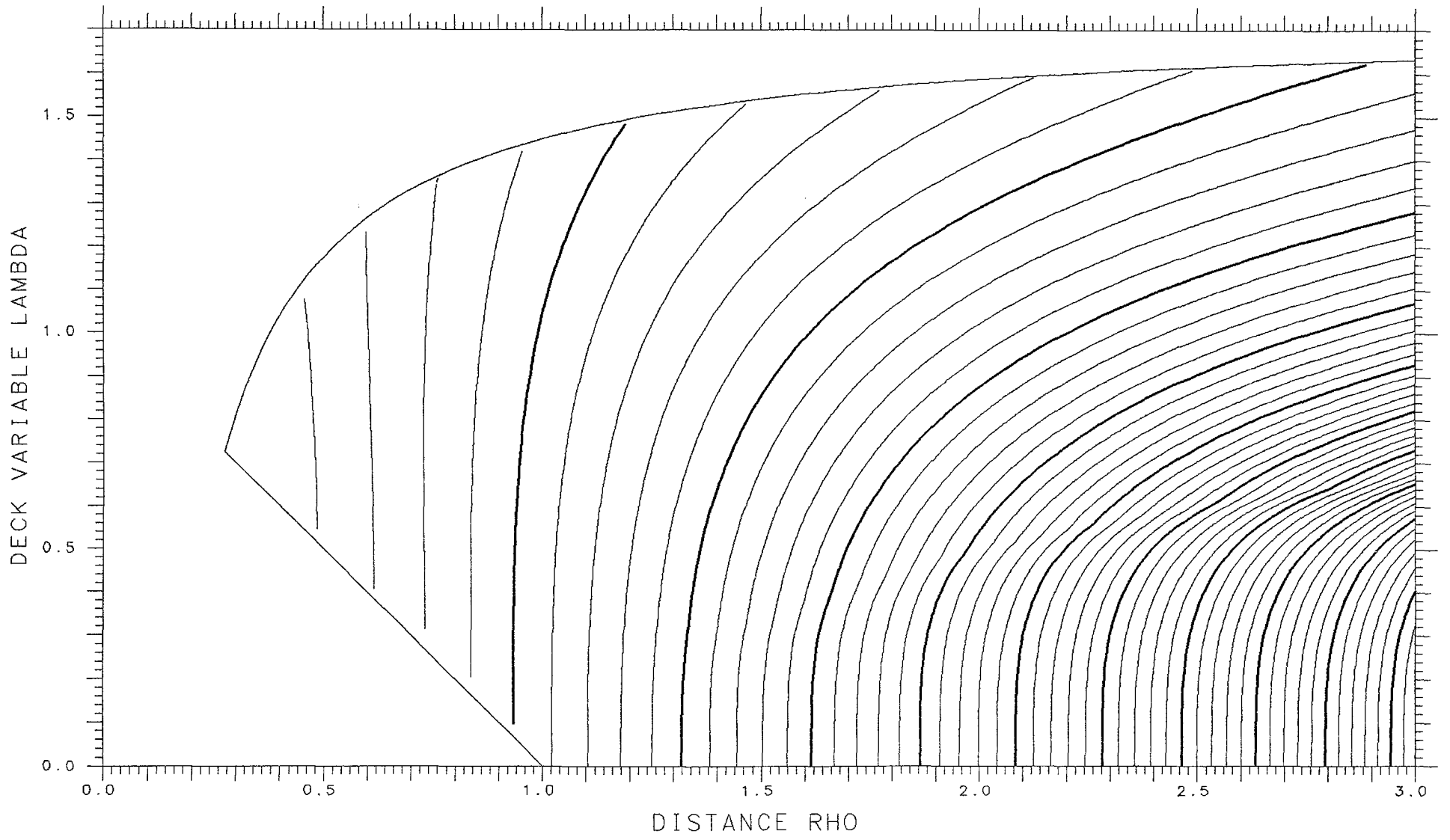

SCALE ASYMMETRY DELTA= .350

SPHERE 1.48148 TANGENT 1.43014 SPACING .010

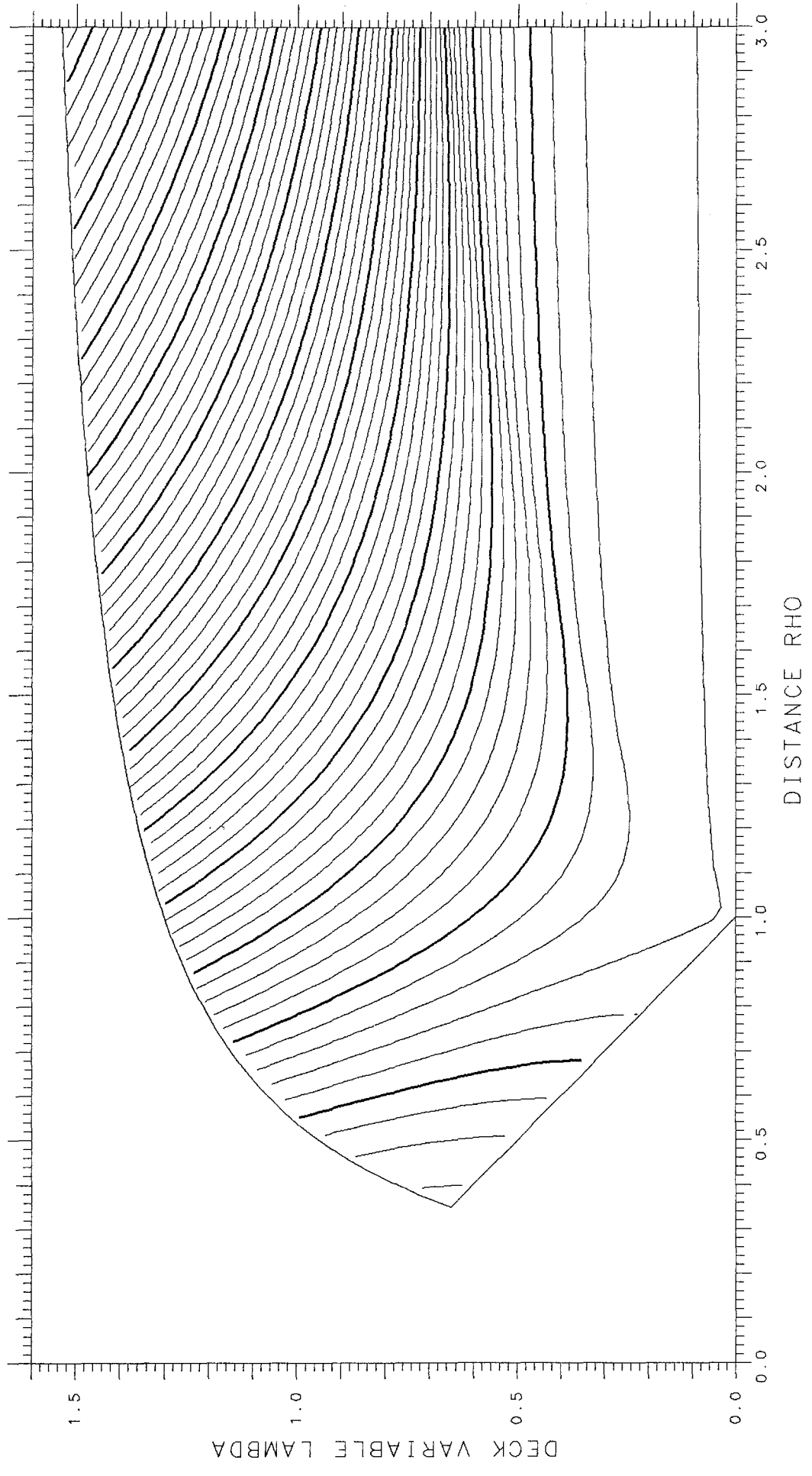

QUADRUPOLE MOMENT ASYMMETRY DELTA= .250

TANGENT .65650 SPACING .10

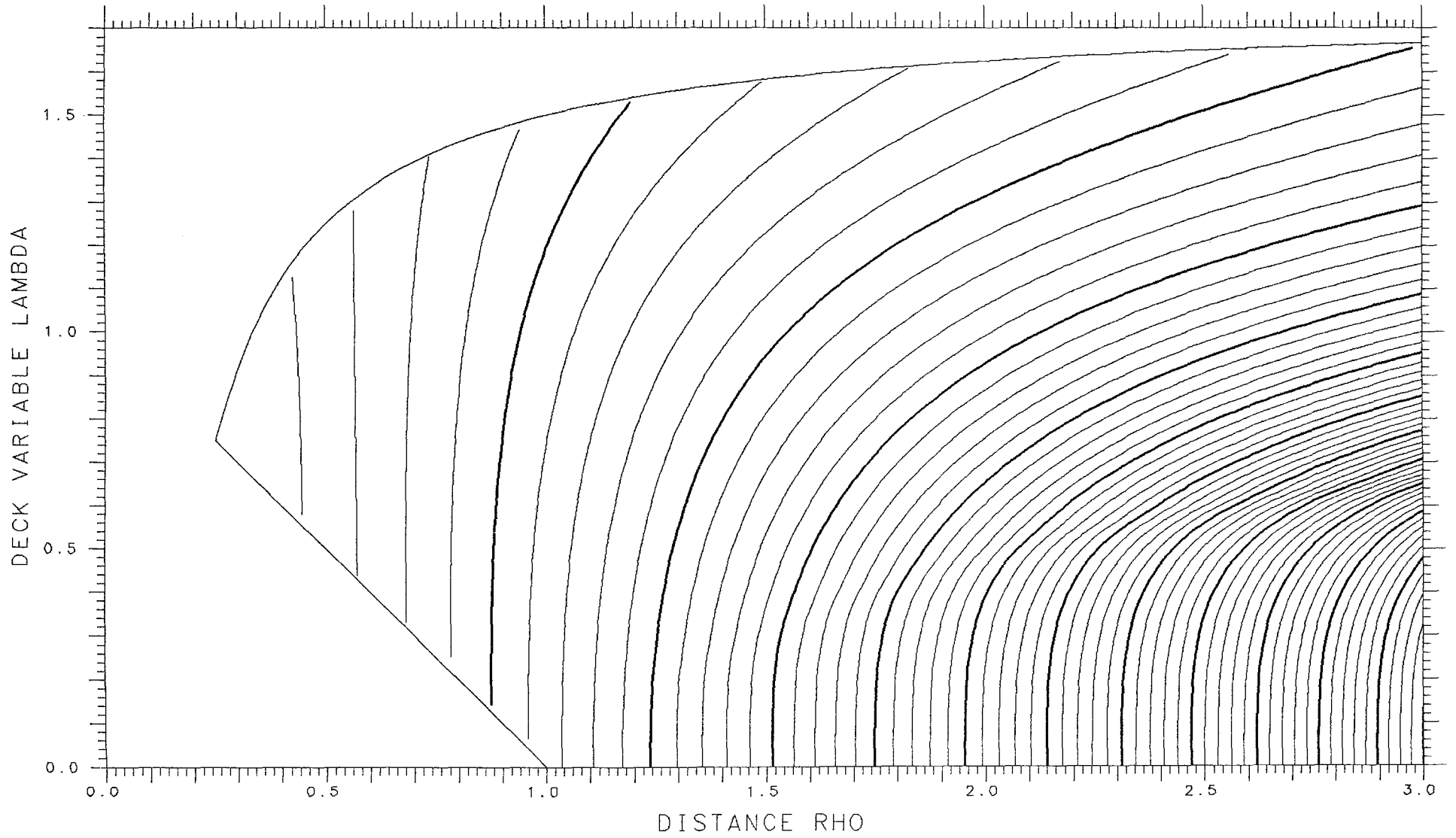

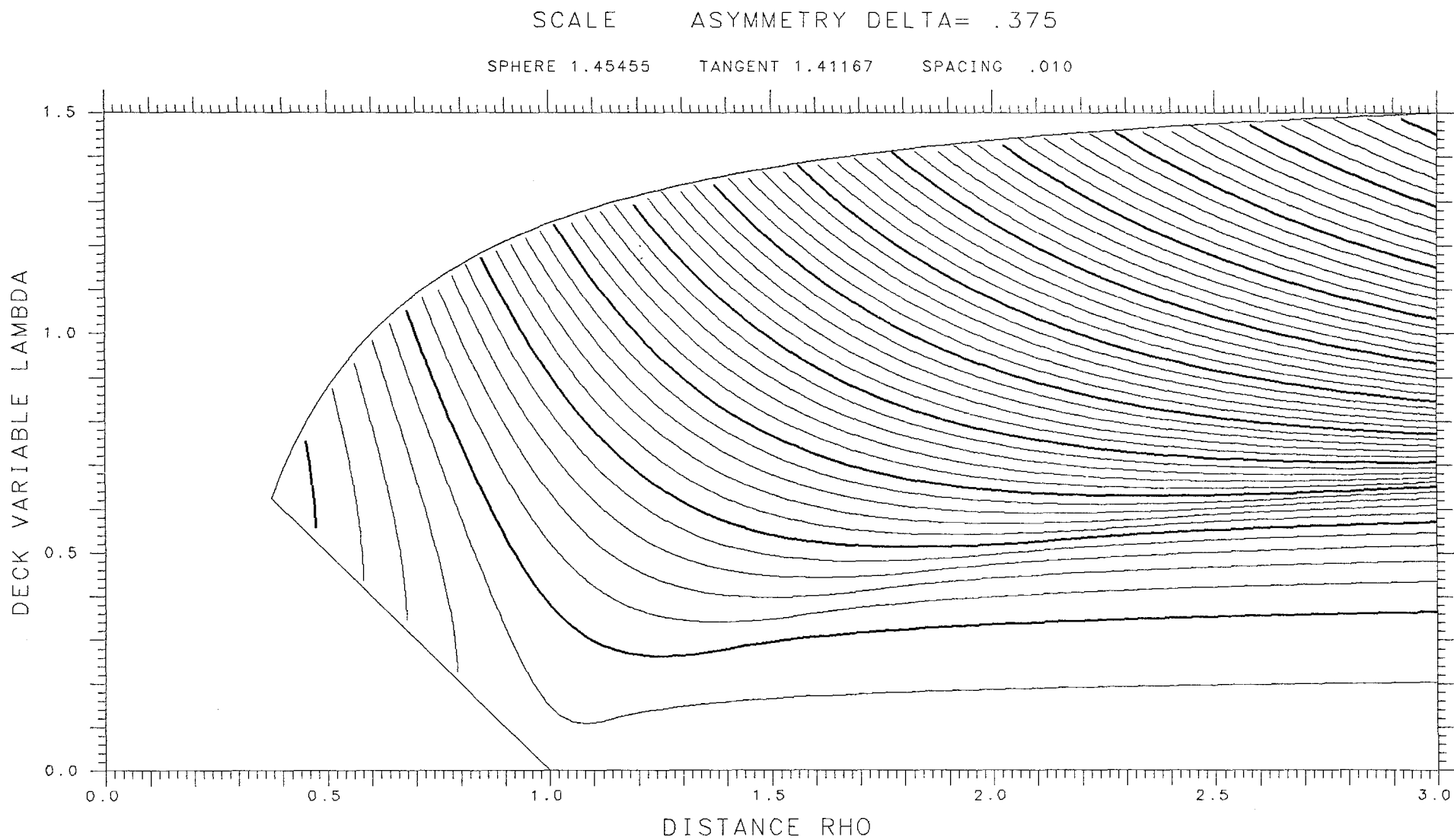

QUADRUPOLE MOMENT ASYMMETRY DELTA= .225

TANGENT .73945 SPACING .10

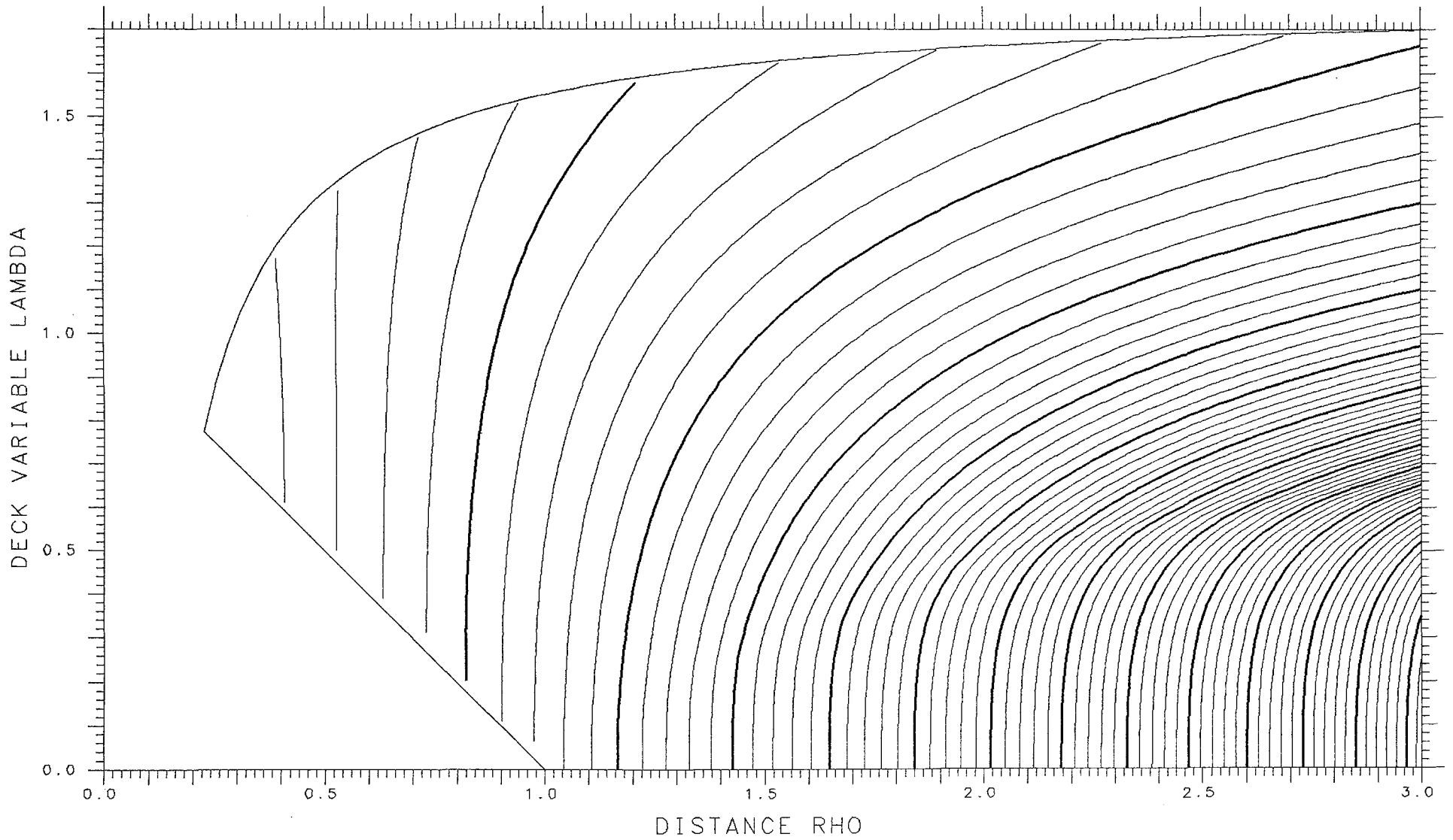

SCALE ASYMMETRY DELTA= .400

SPHERE 1.42857 TANGENT 1.39294 SPACING .010

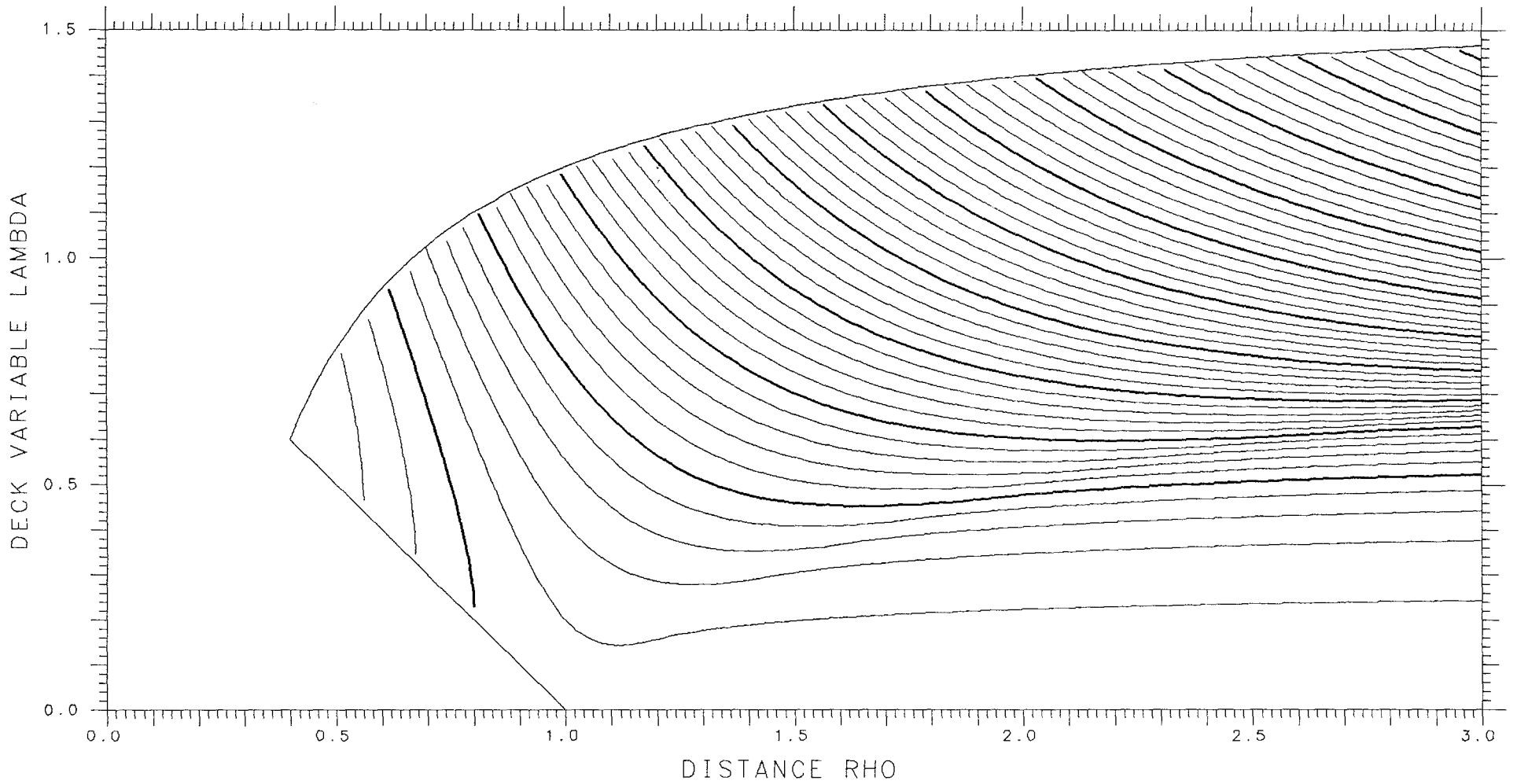

QUADRUPOLE MOMENT ASYMMETRY DELTA= .200

TANGENT .82397 SPACING .10

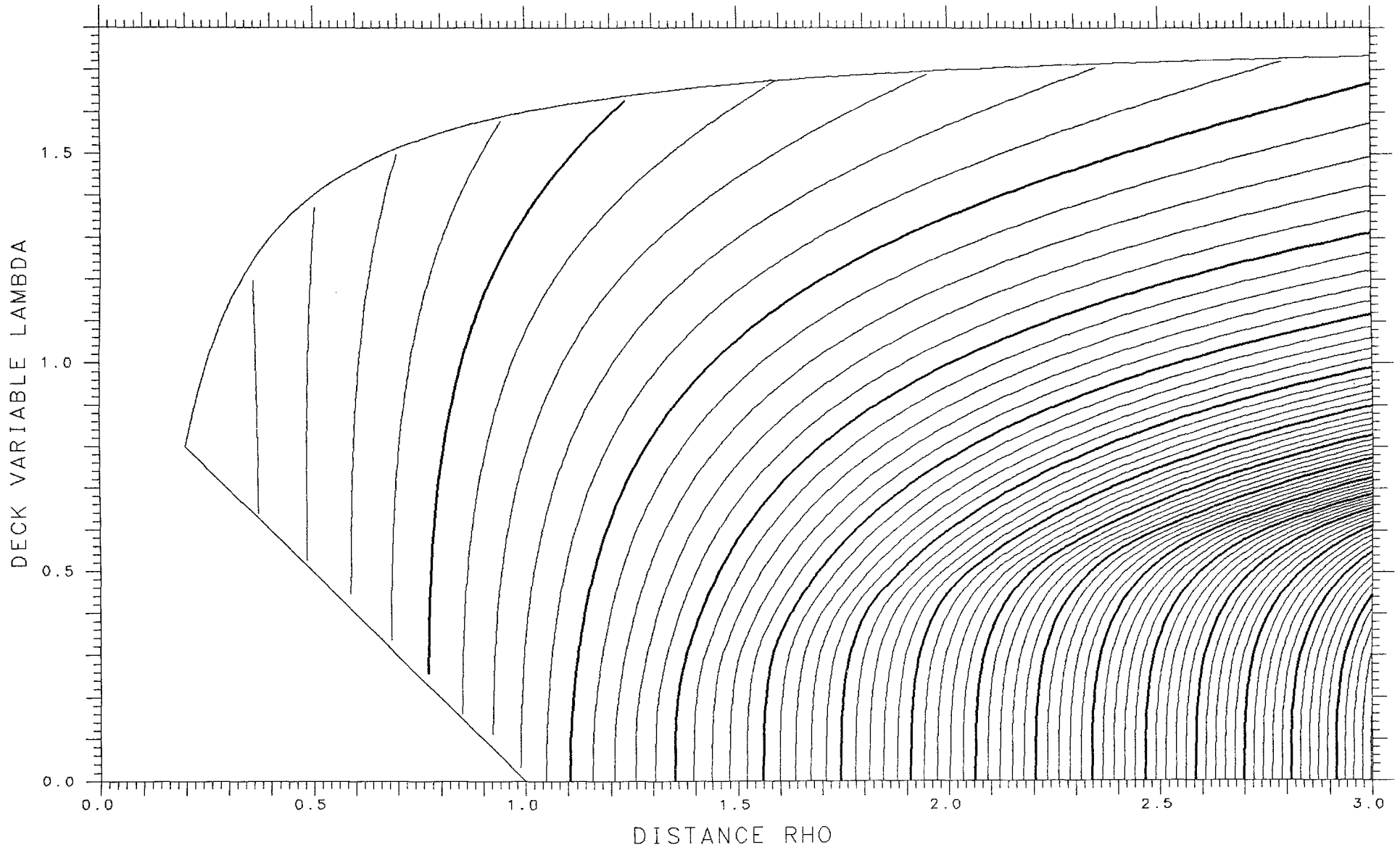

SCALE ASYMMETRY DELTA= .425

SPHERE 1.40351 TANGENT 1.37405 SPACING .010

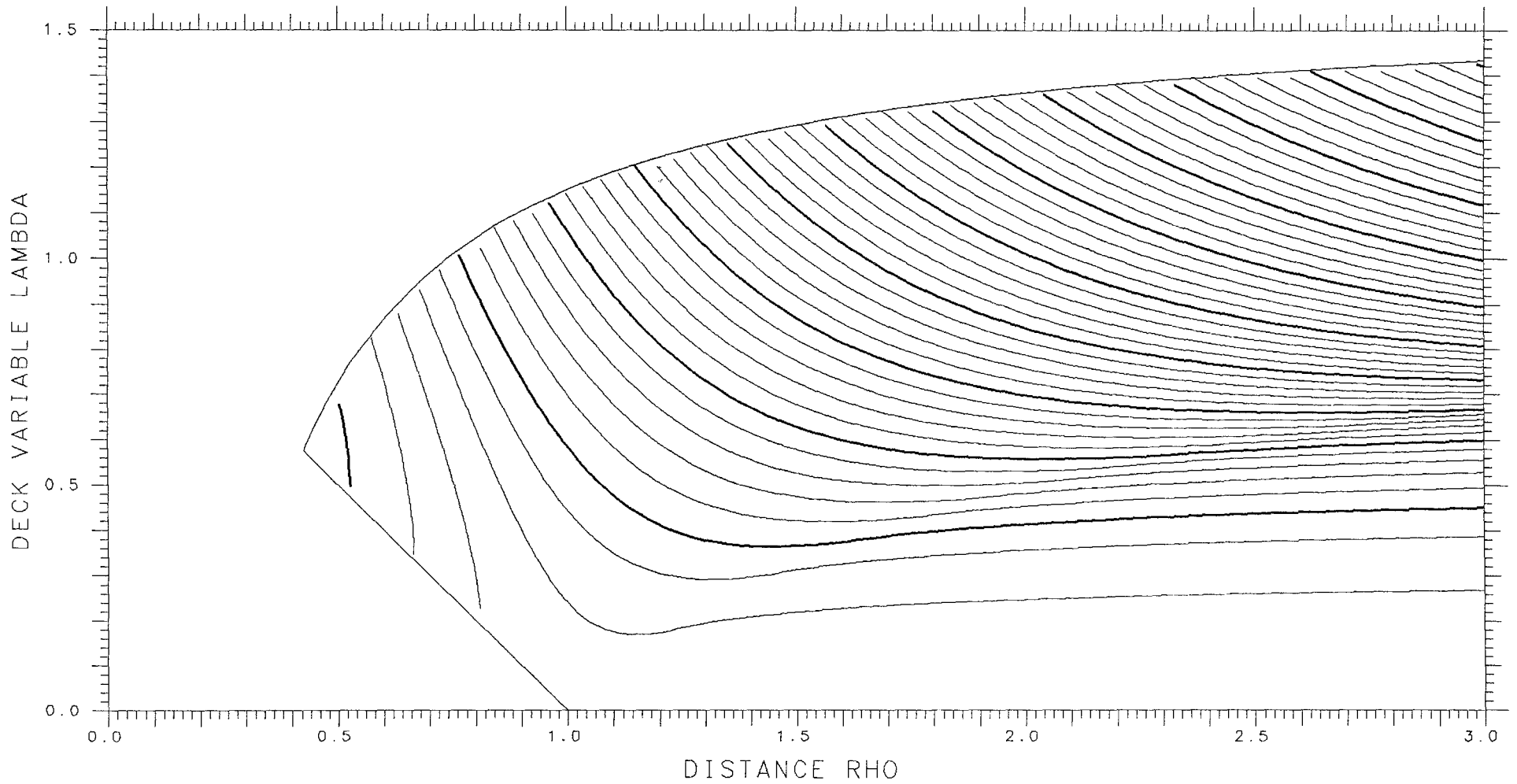

QUADRUPOLE MOMENT ASYMMETRY DELTA= .175

TANGENT .90787 SPACING .10

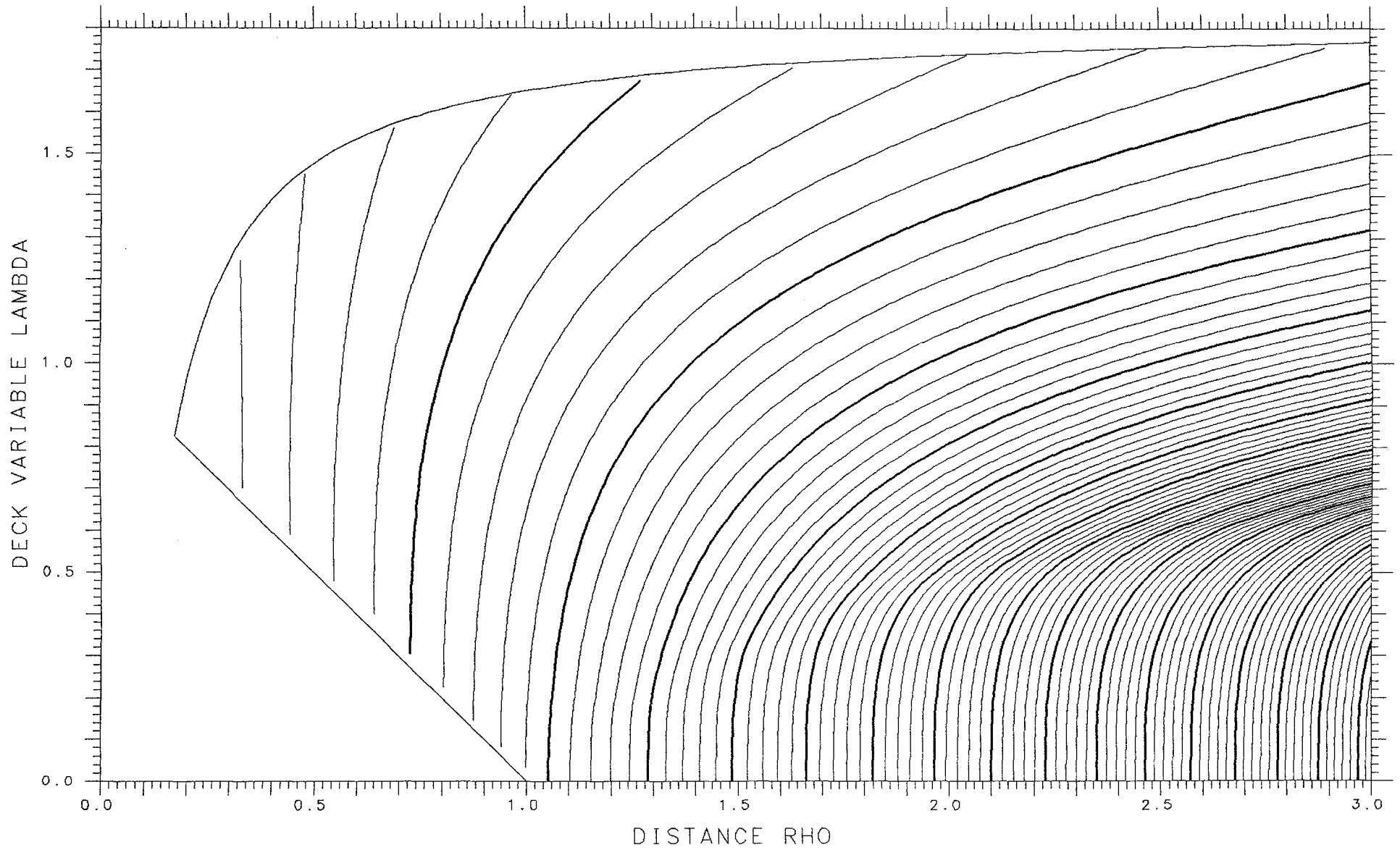

SCALE ASYMMETRY DELTA= .450

SPHERE 1.37931 TANGENT 1.35509 SPACING .010

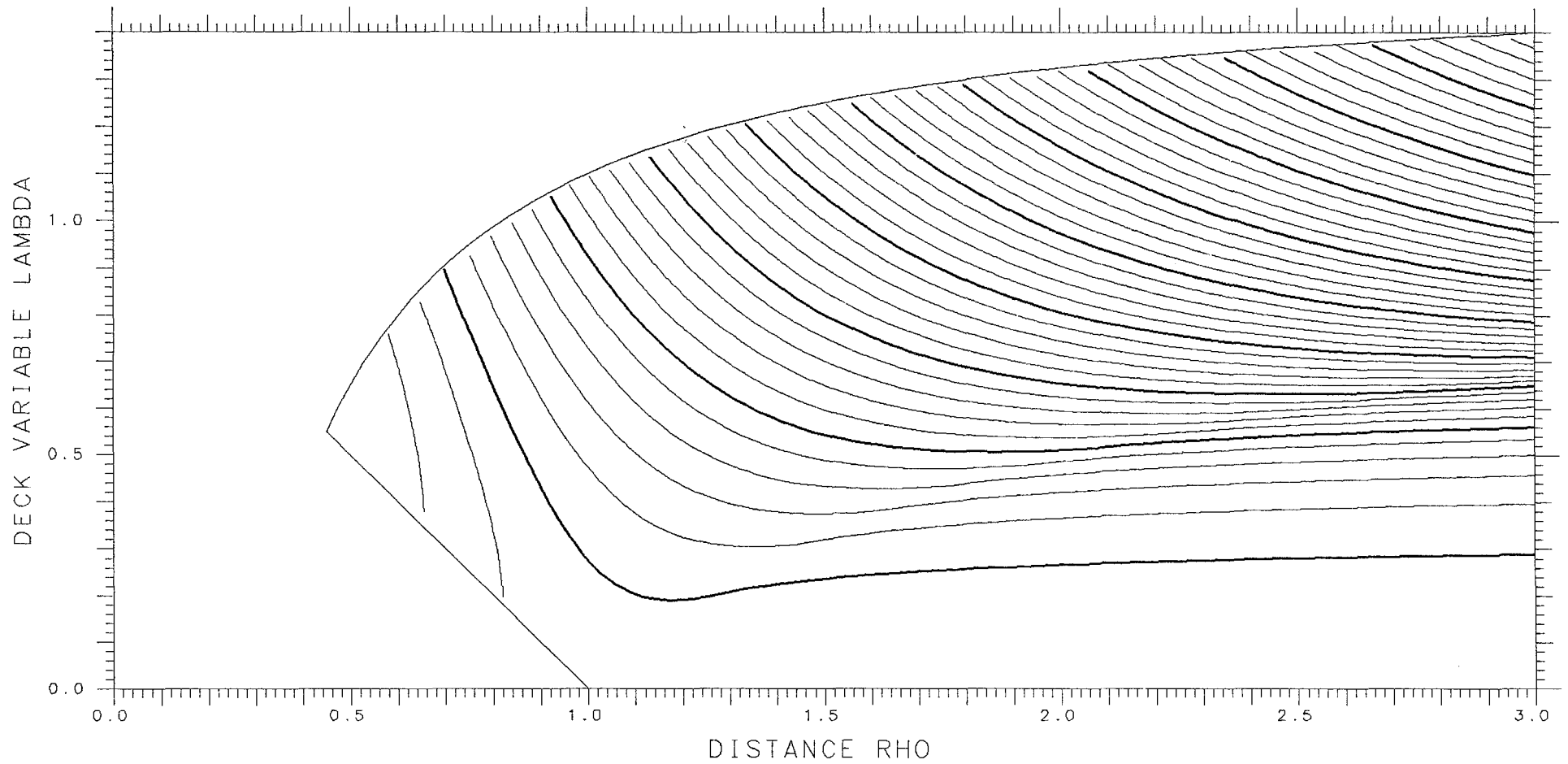

QUADRUPOLE MOMENT ASYMMETRY DELTA= .150

TANGENT .98866 SPACING .10

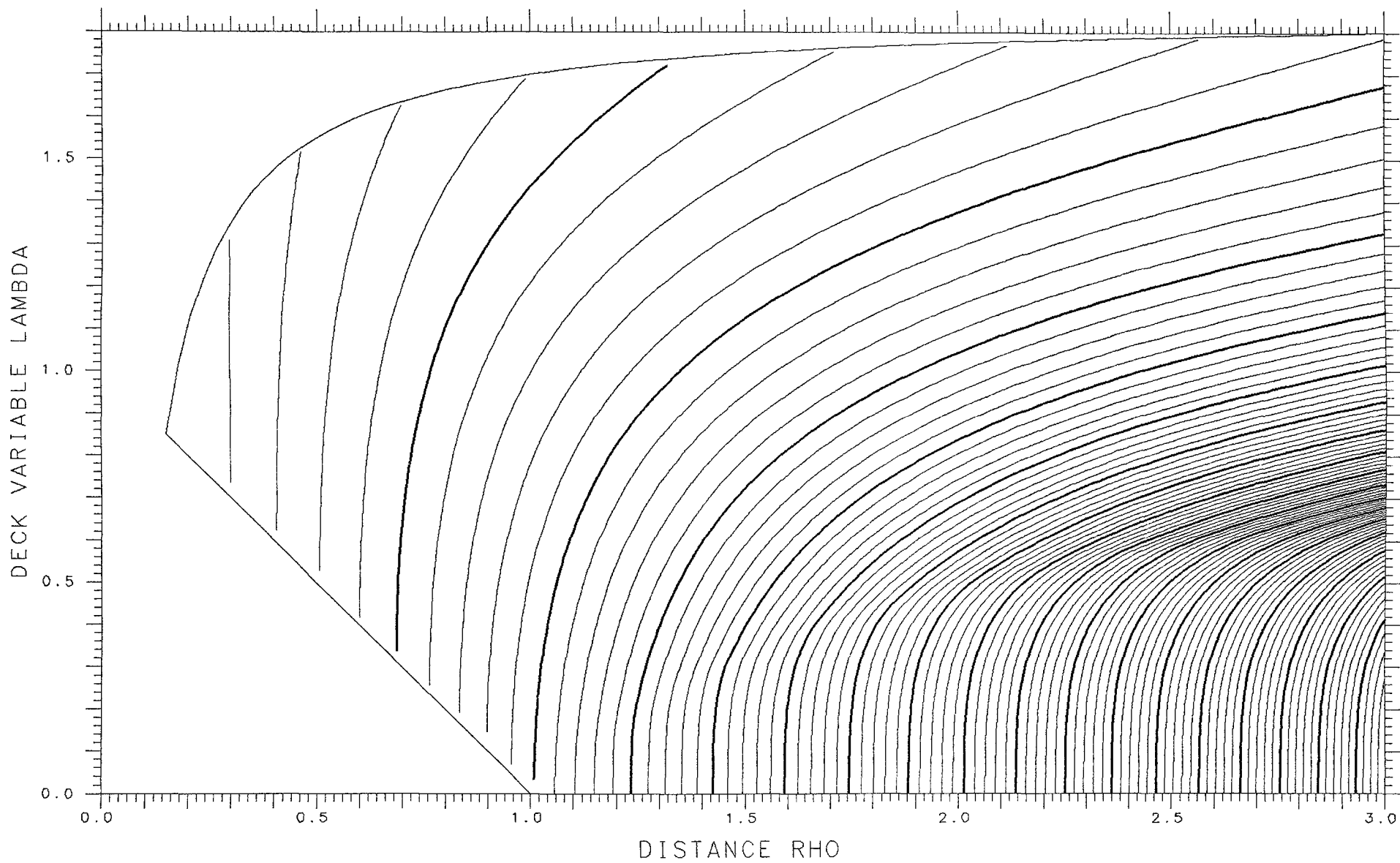

SCALE ASYMMETRY DELTA= .475

SPHERE 1.35593 TANGENT 1.33614 SPACING .010

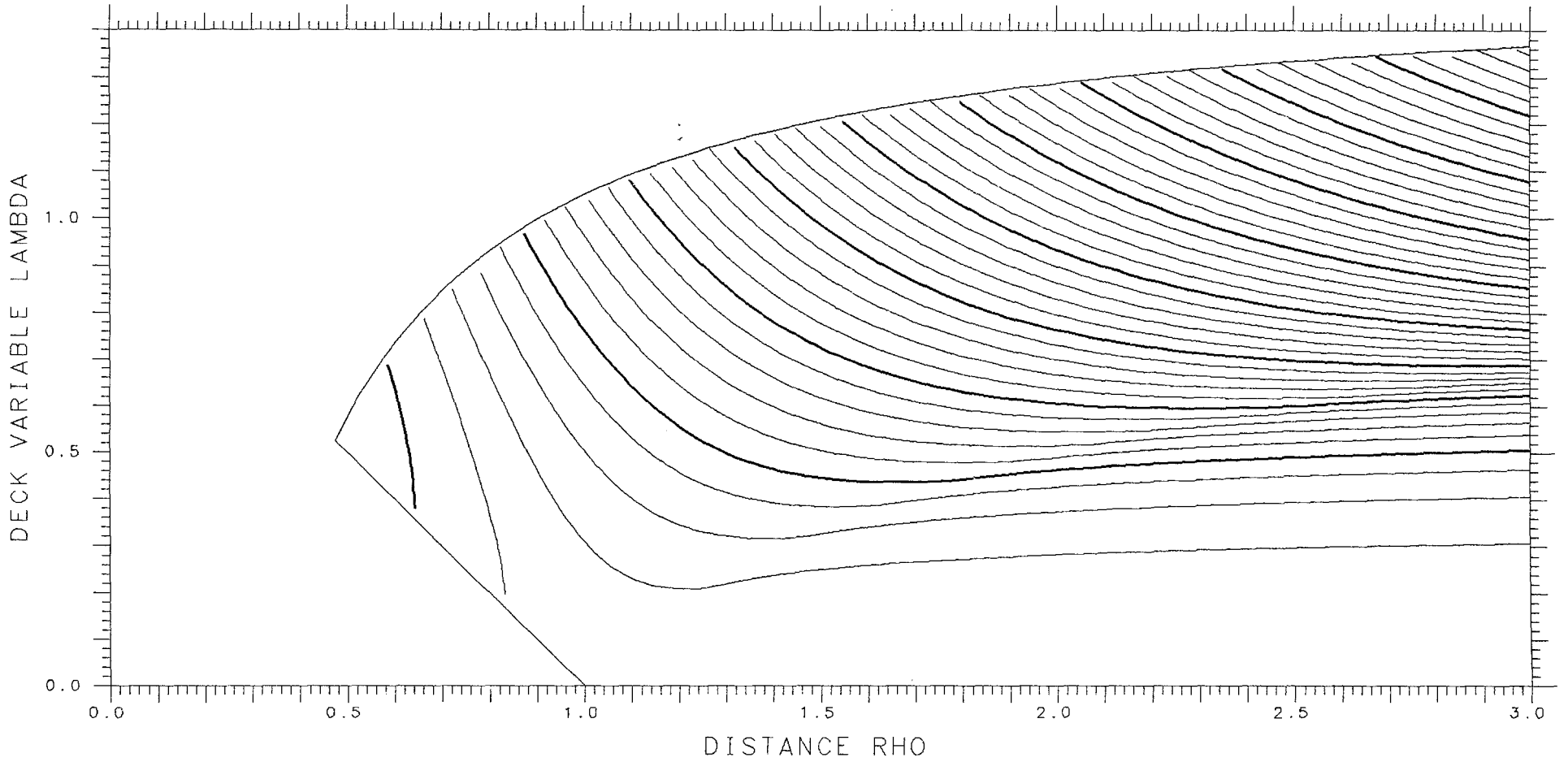

QUADRUPOLE MOMENT ASYMMETRY DELTA= .125

TANGENT 1.06358 SPACING .10

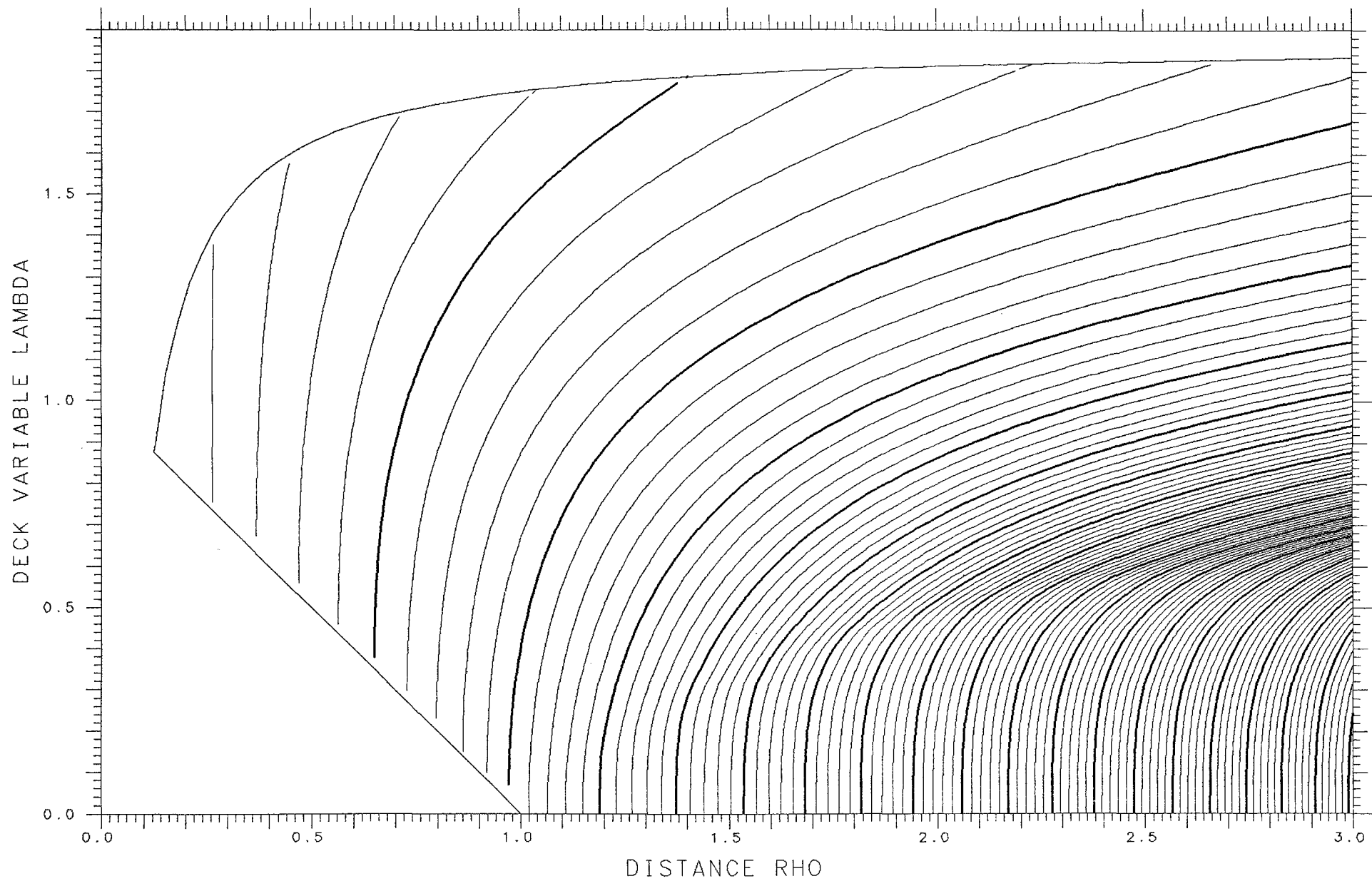

SCALE ASYMMETRY DELTA= .500

SPHERE 1.33333 TANGENT 1.31727 SPACING .010

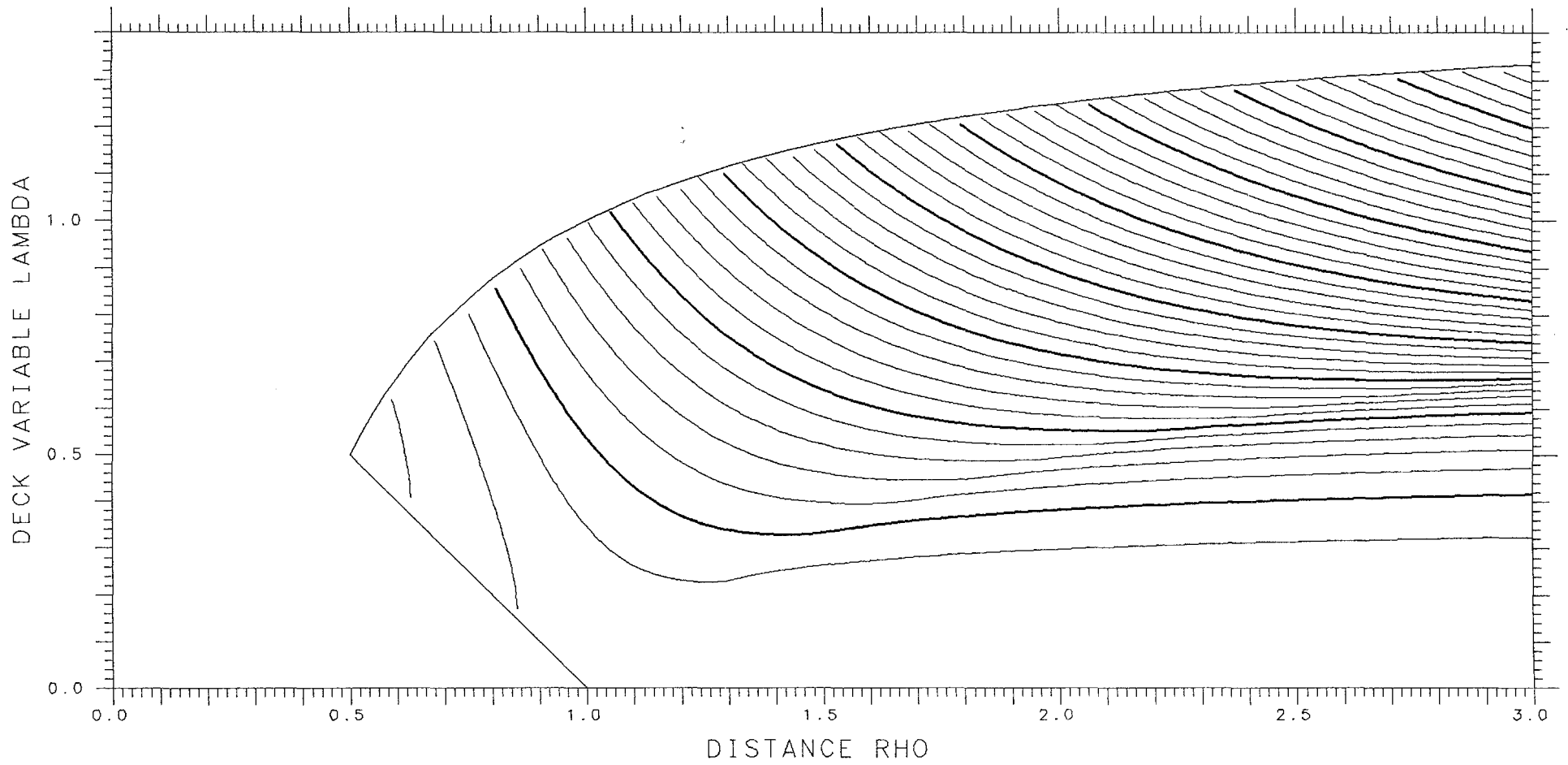

QUADRUPOLE MOMENT ASYMMETRY DELTA= .100

TANGENT 1.12984 SPACING .10

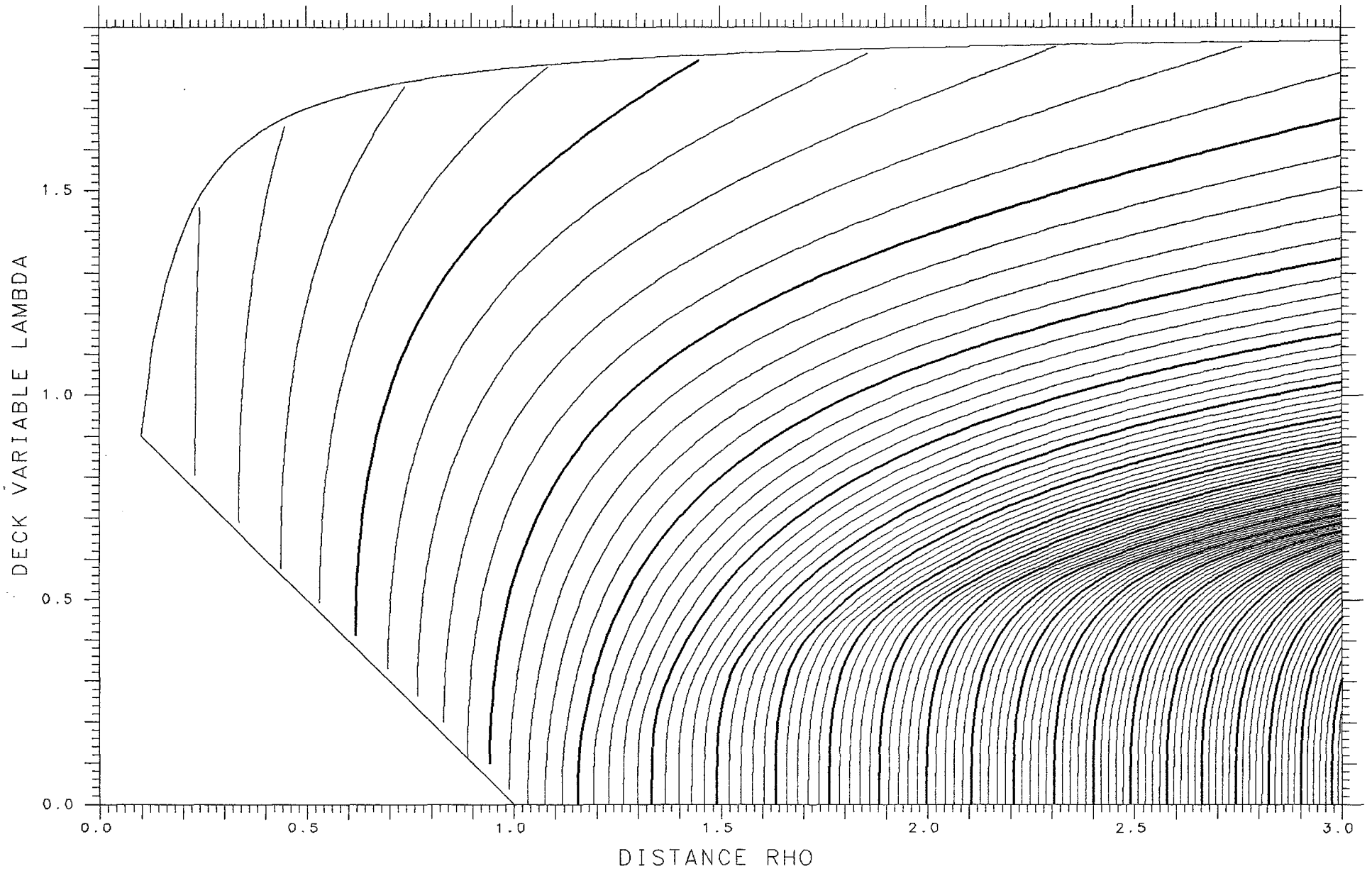

SCALE ASYMMETRY DELTA= .525

SPHERE 1.31148 TANGENT 1.29853 SPACING .010

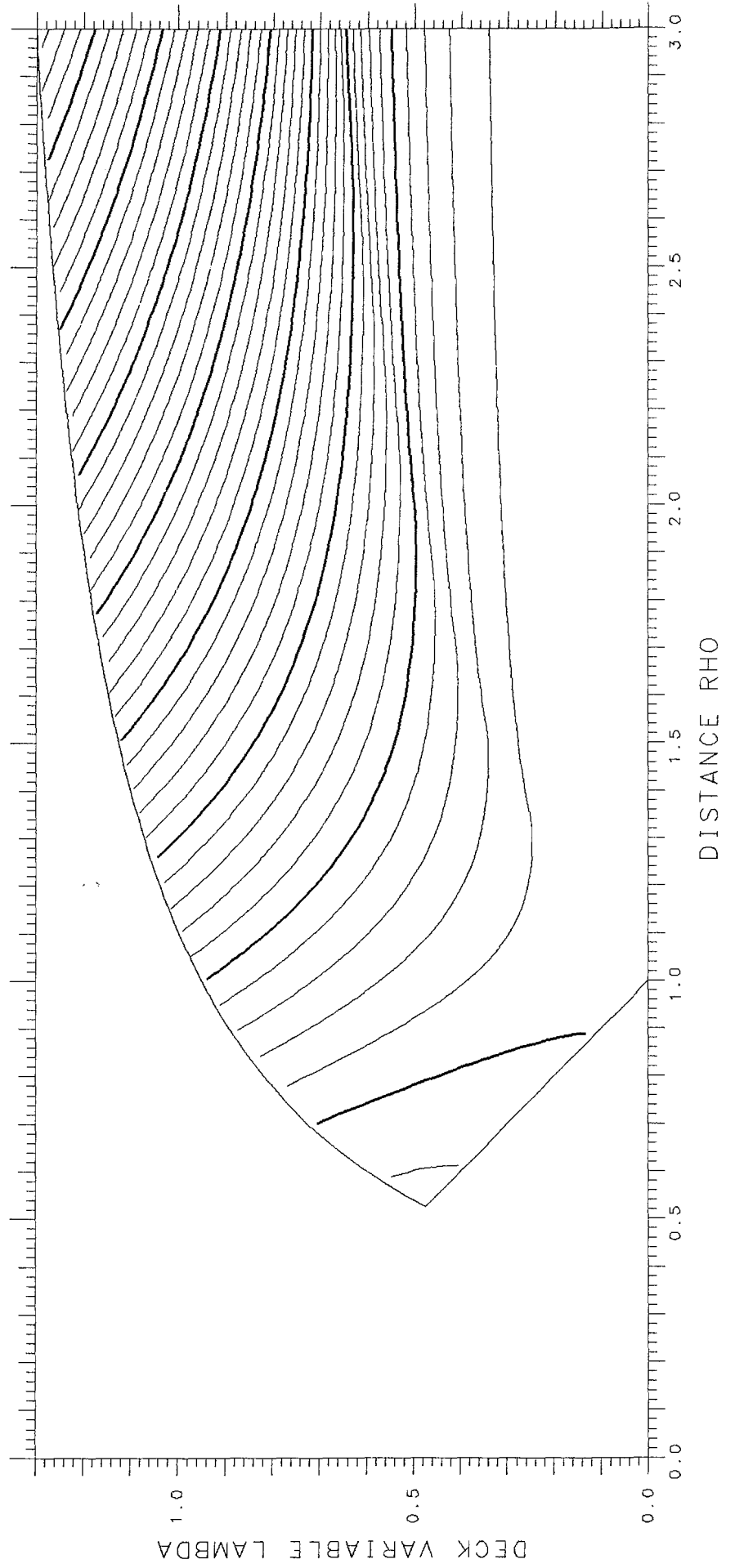

QUADRUPOLE MOMENT ASYMMETRY DELTA= .075

TANGENT 1.18471 SPACING .10

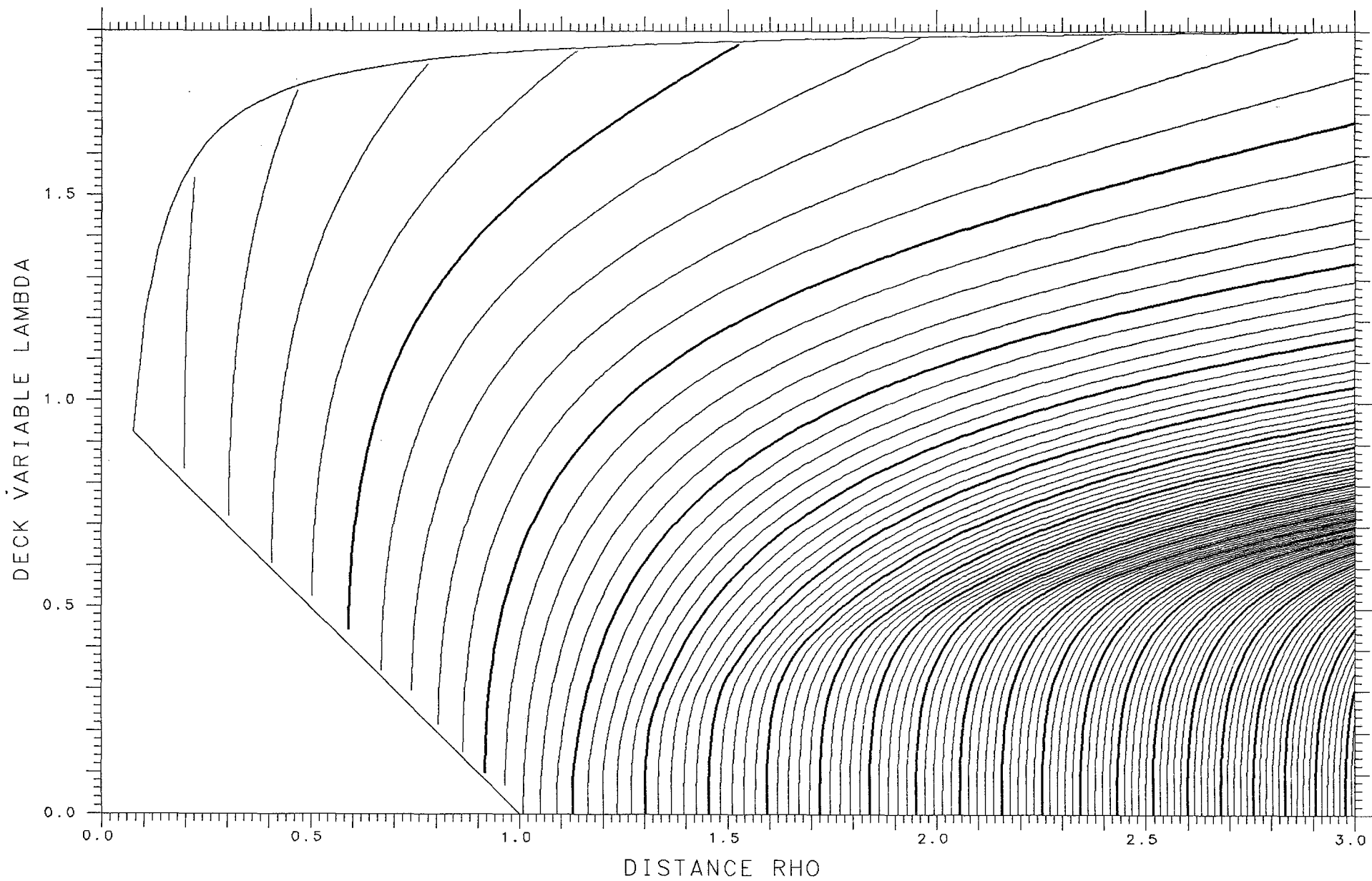

SCALE ASYMMETRY DELTA= .550

SPHERE 1.29032 TANGENT 1.27997 SPACING .010

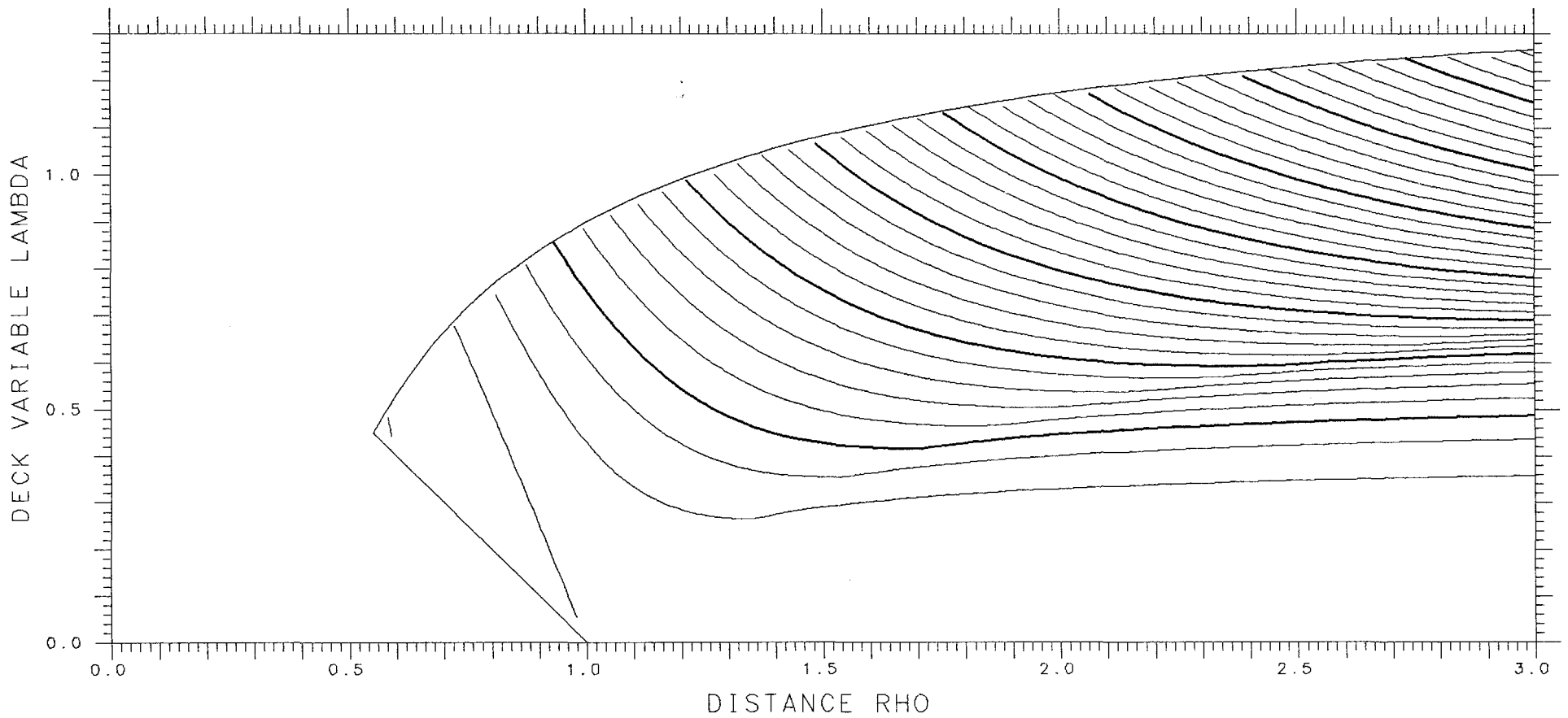

QUADRUPOLE MOMENT ASYMMETRY DELTA= .050

TANGENT 1.22583 SPACING .10

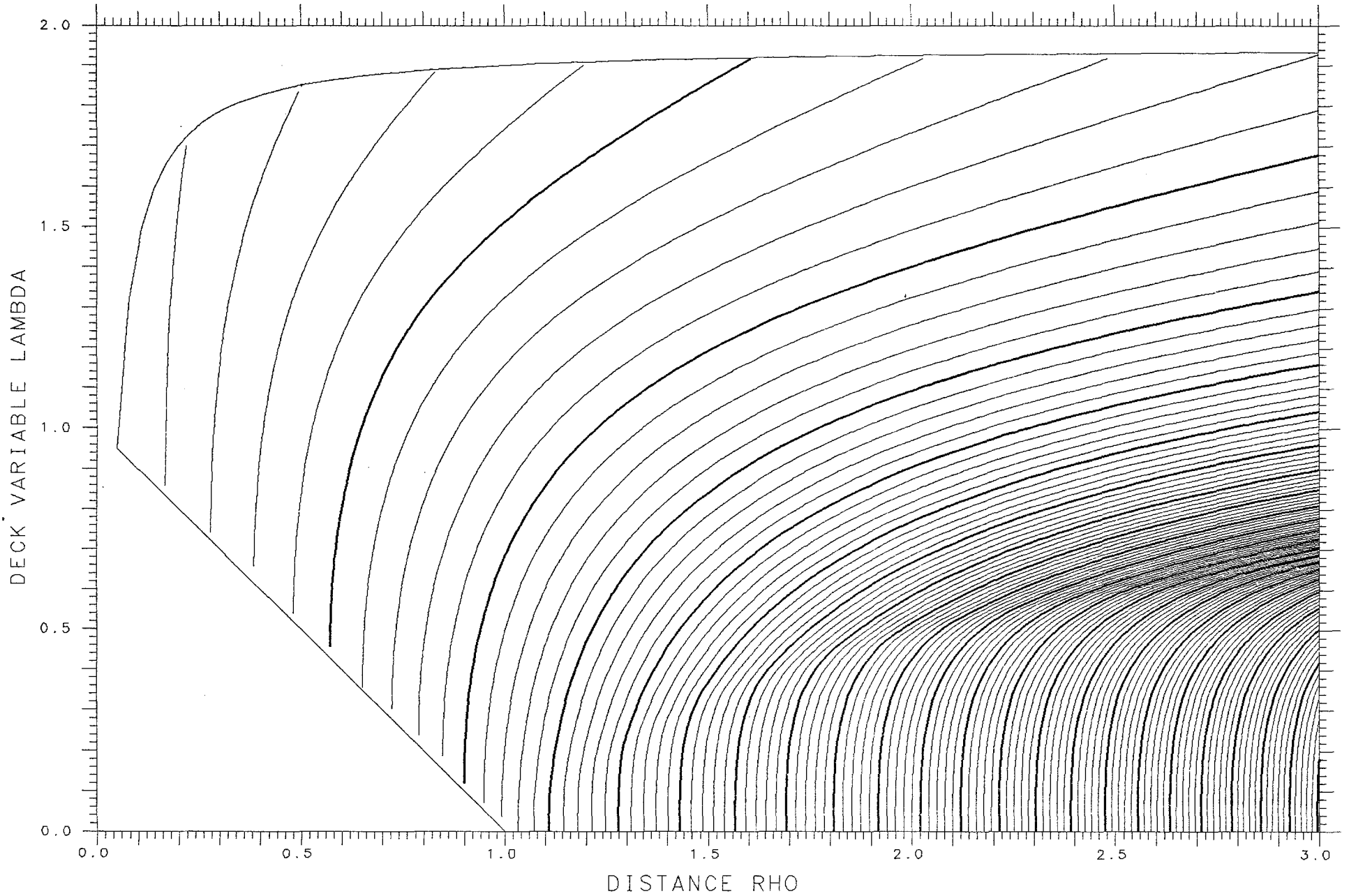

SCALE ASYMMETRY DELTA= .575

SPHERE 1.26984 TANGENT 1.26163 SPACING .010

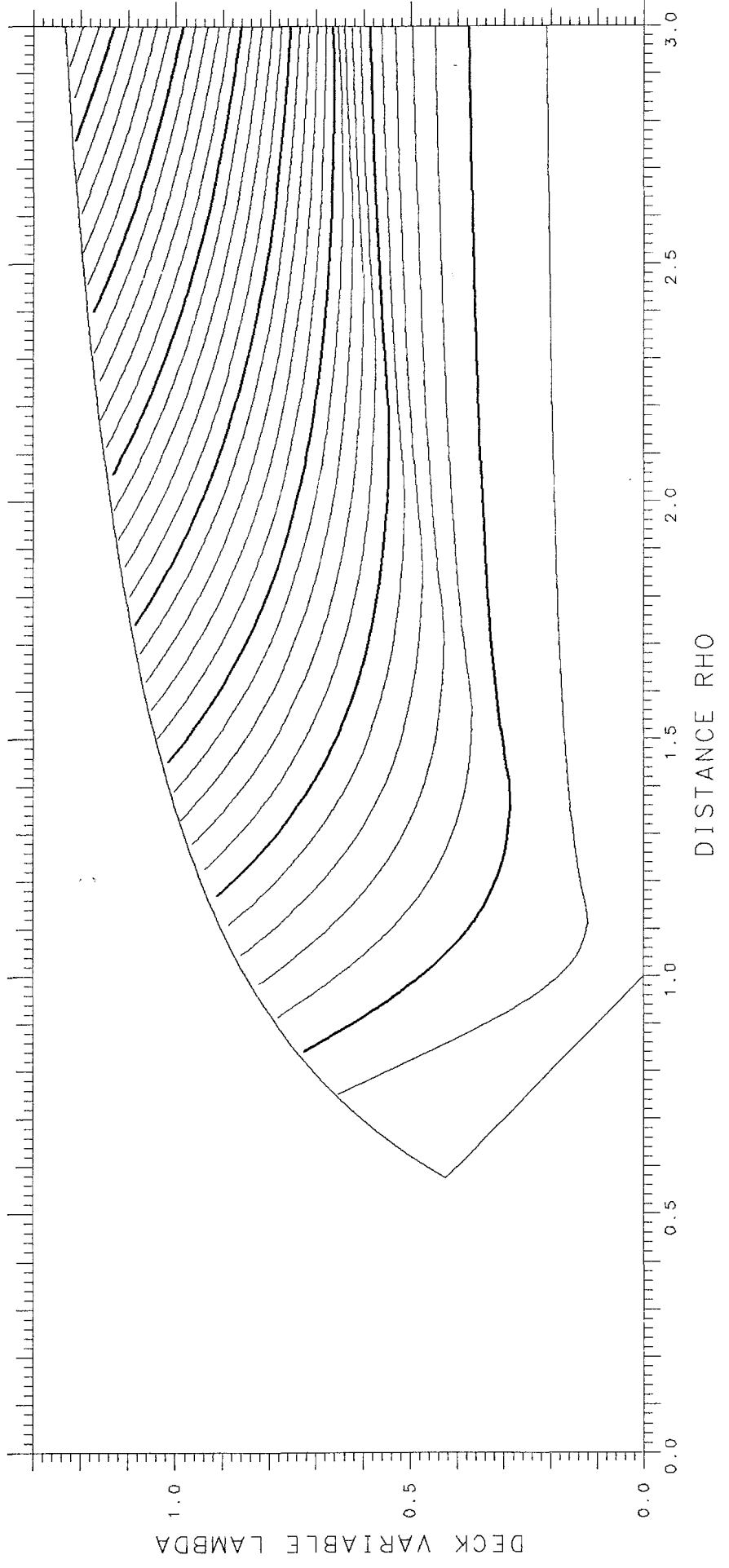

QUADRUPOLE MOMENT ASYMMETRY DELTA= .025

TANGENT 1.25129 SPACING .10

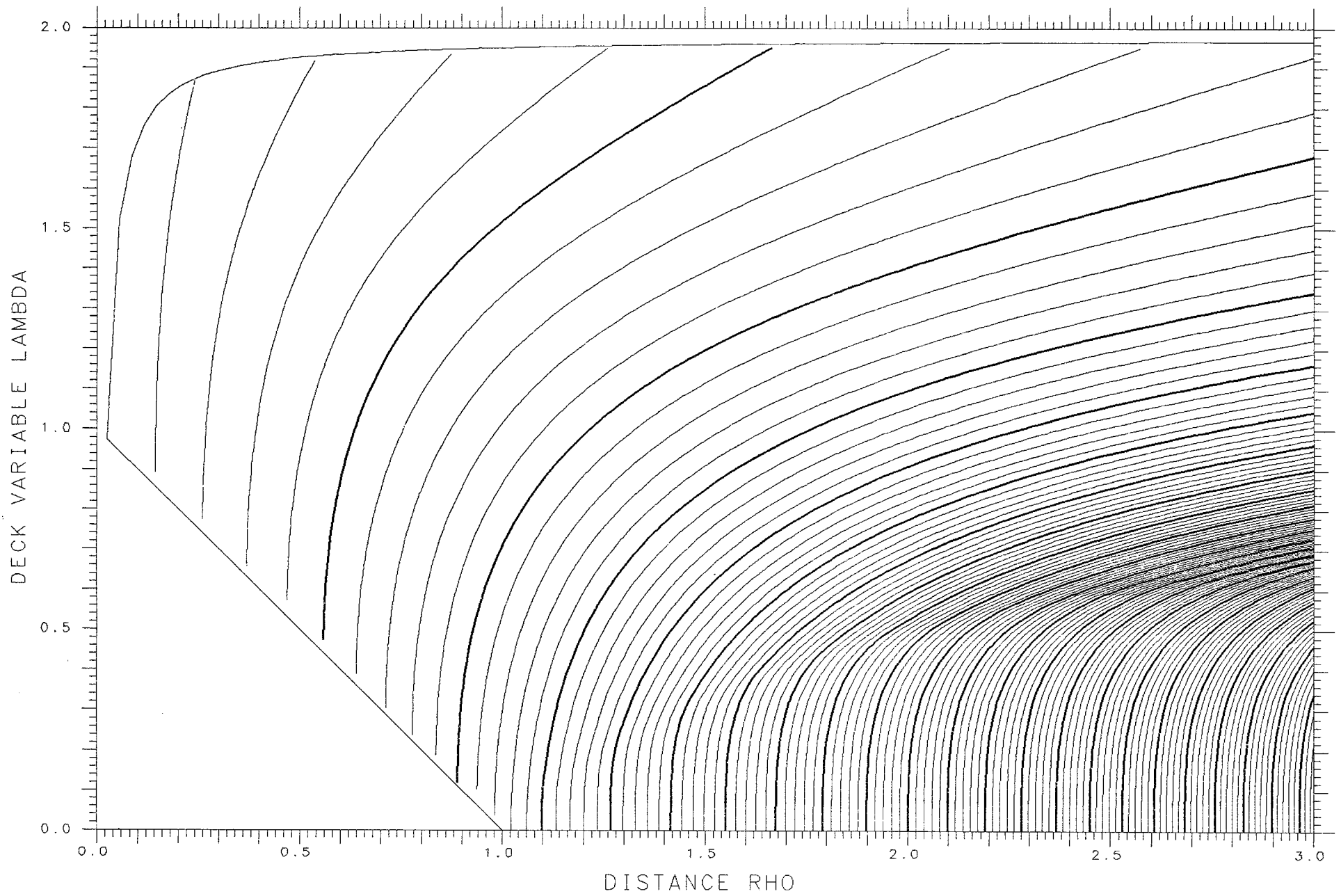

SCALE ASYMMETRY DELTA= .600

SPHERE 1.25000 TANGENT 1.24356 SPACING .010

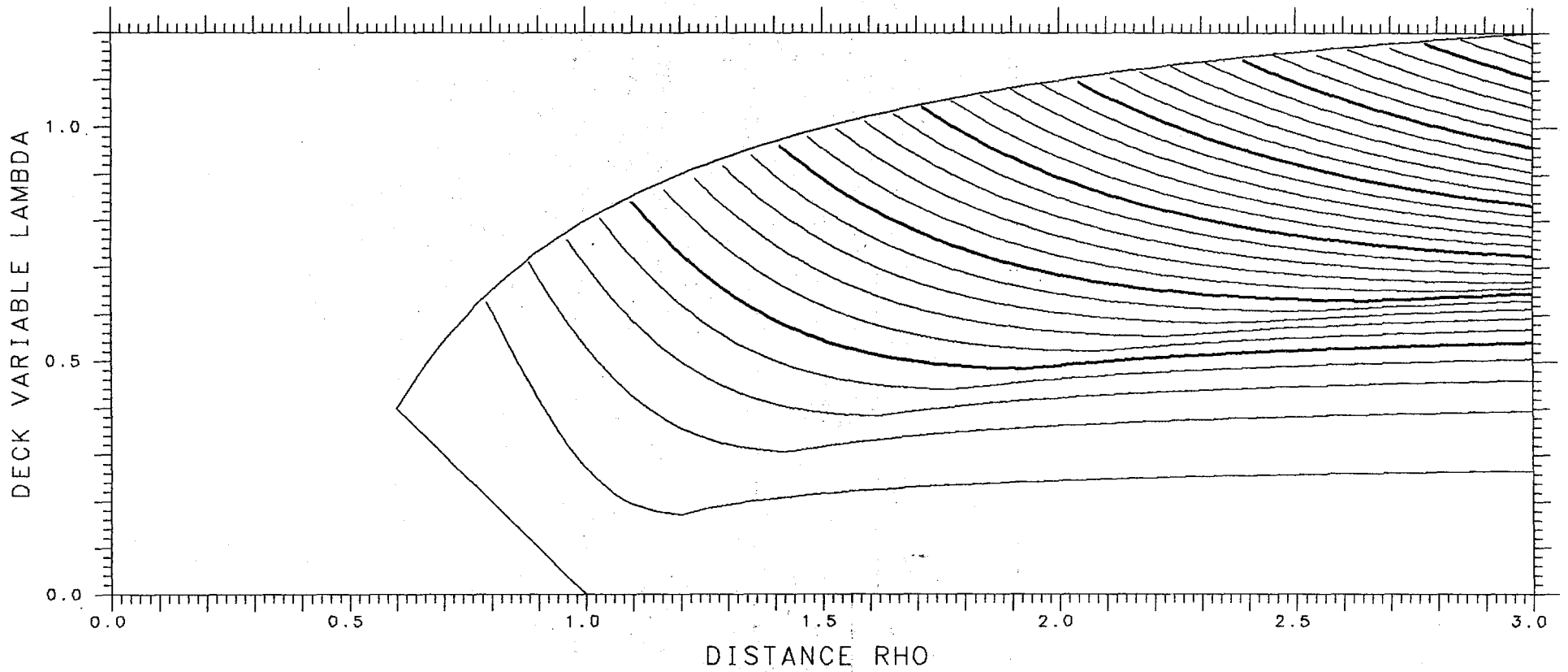

QUADRUPOLE MOMENT ASYMMETRY DELTA=0.

TANGENT 1.25992 SPACING .10

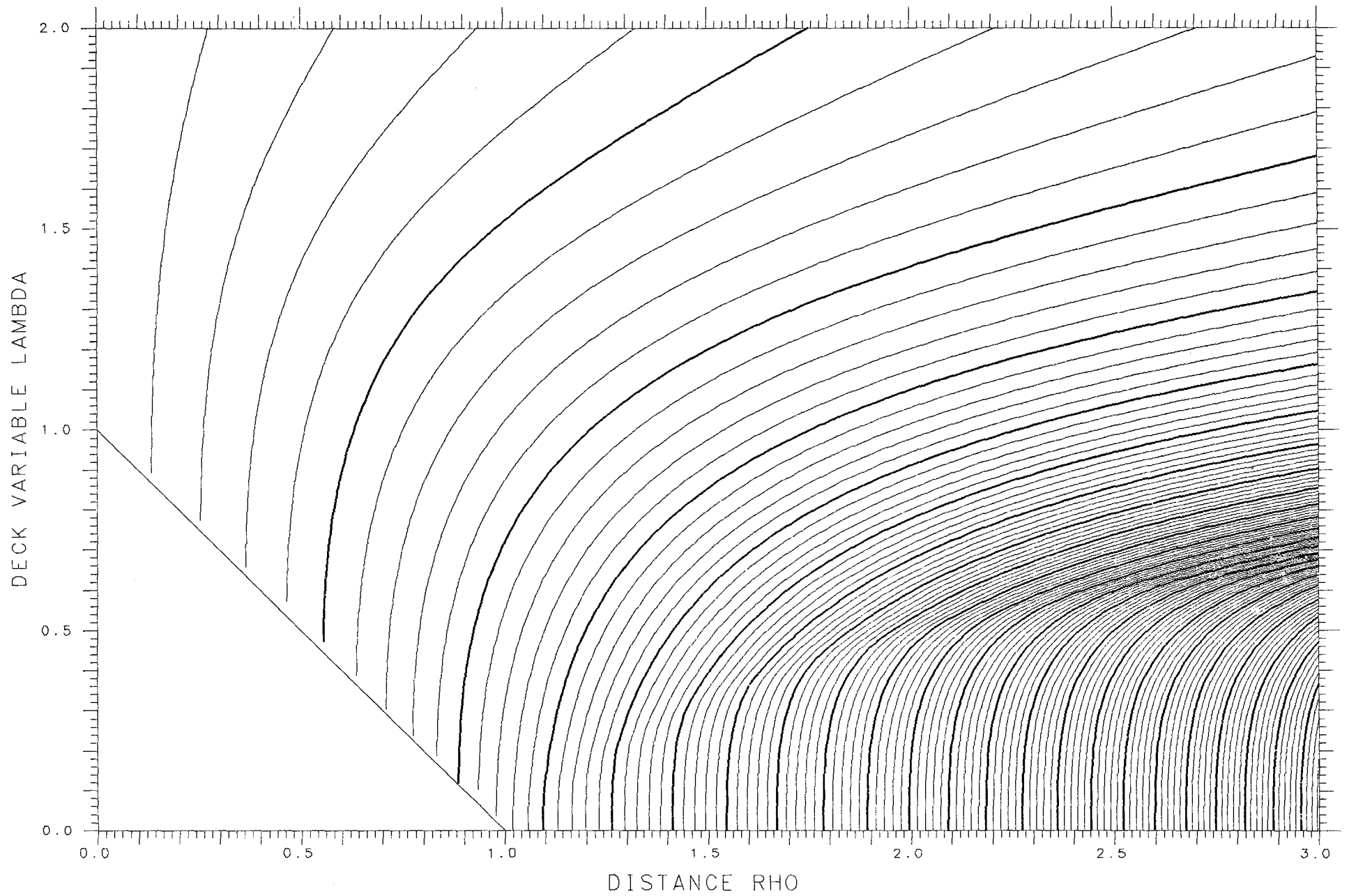

INERTIA PERPENDICULAR ASYMMETRY DELTA=0.

TANGENT 2.20486 SPACING .10

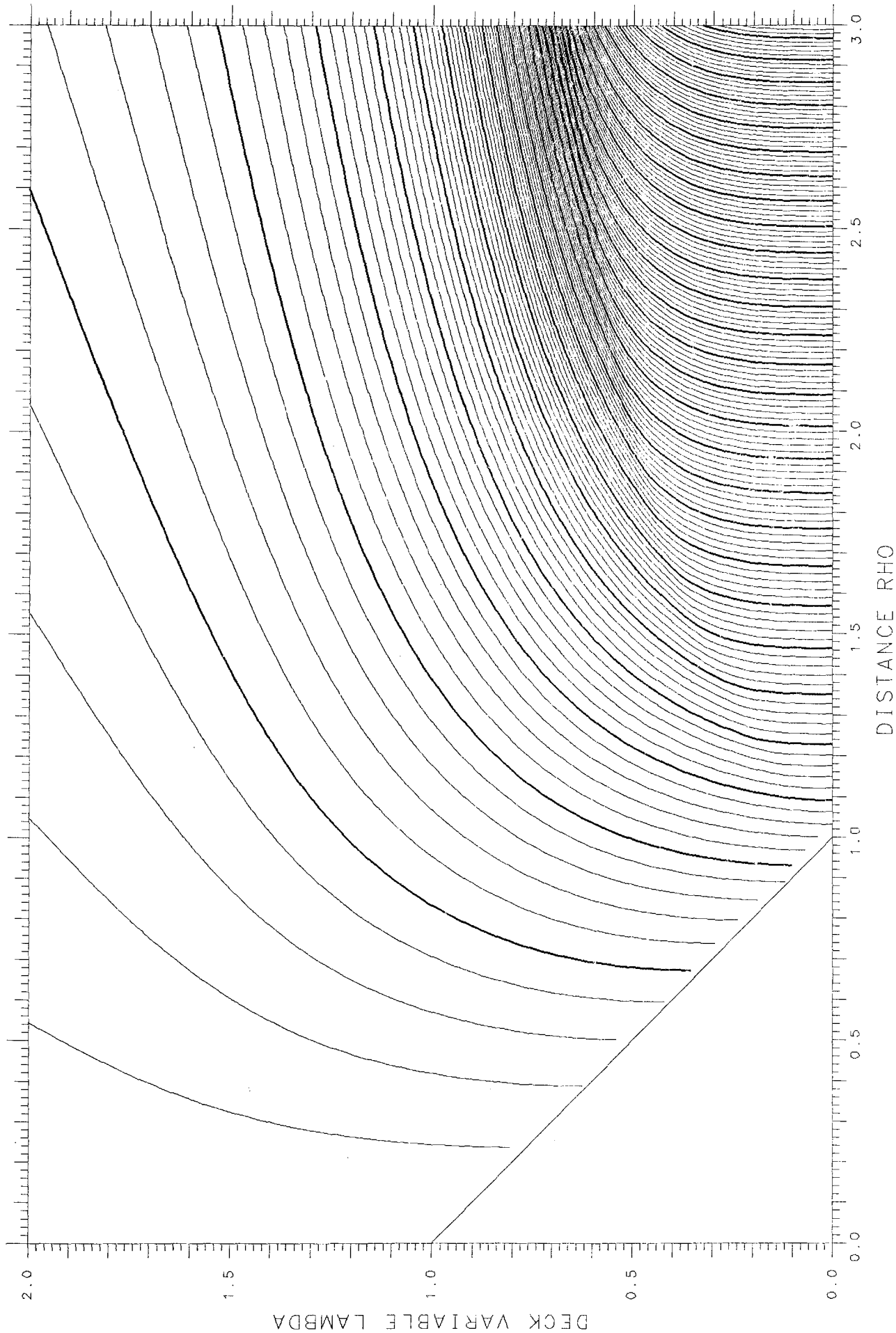

INERTIA PARALLEL ASYMMETRY DELTA= .600

TANGENT .97544 SPACING .01

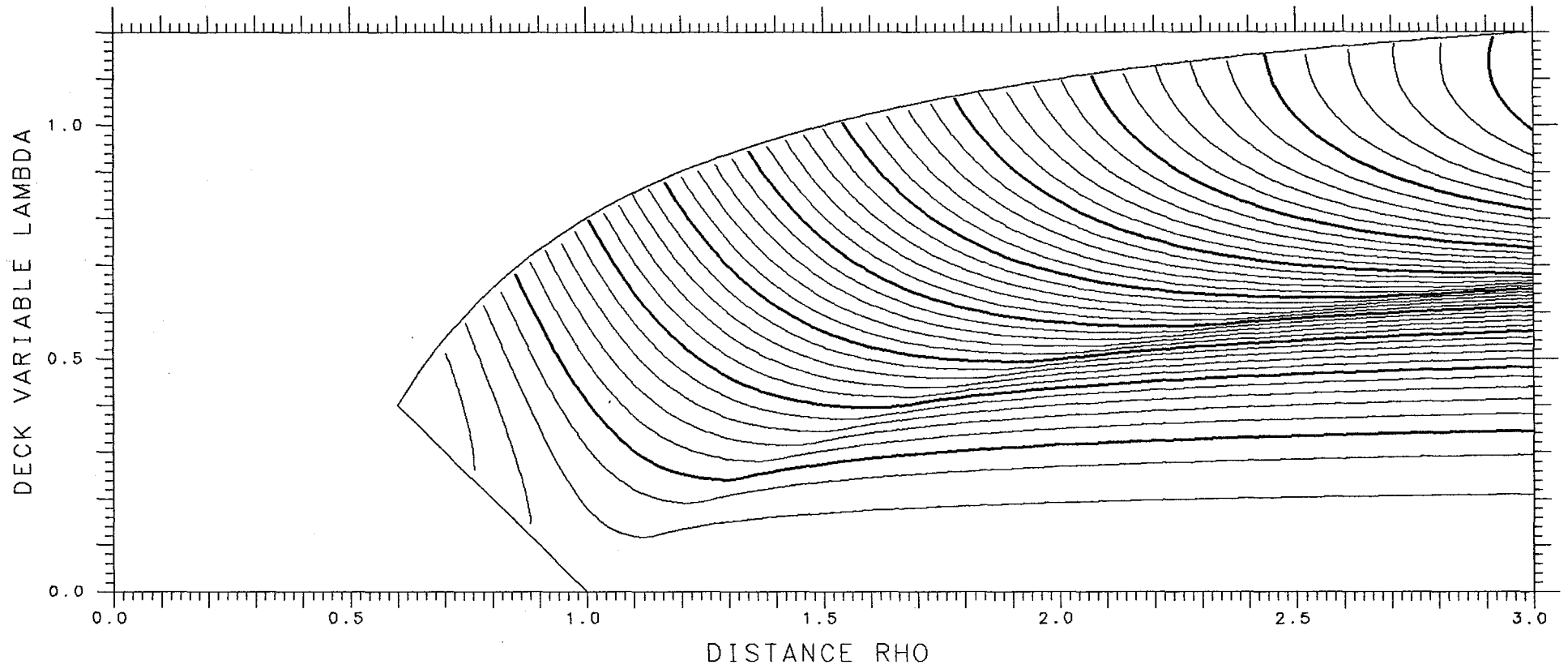

INERTIA PERPENDICULAR ASYMMETRY DELTA= .025

TANGENT 2.19604 SPACING .10

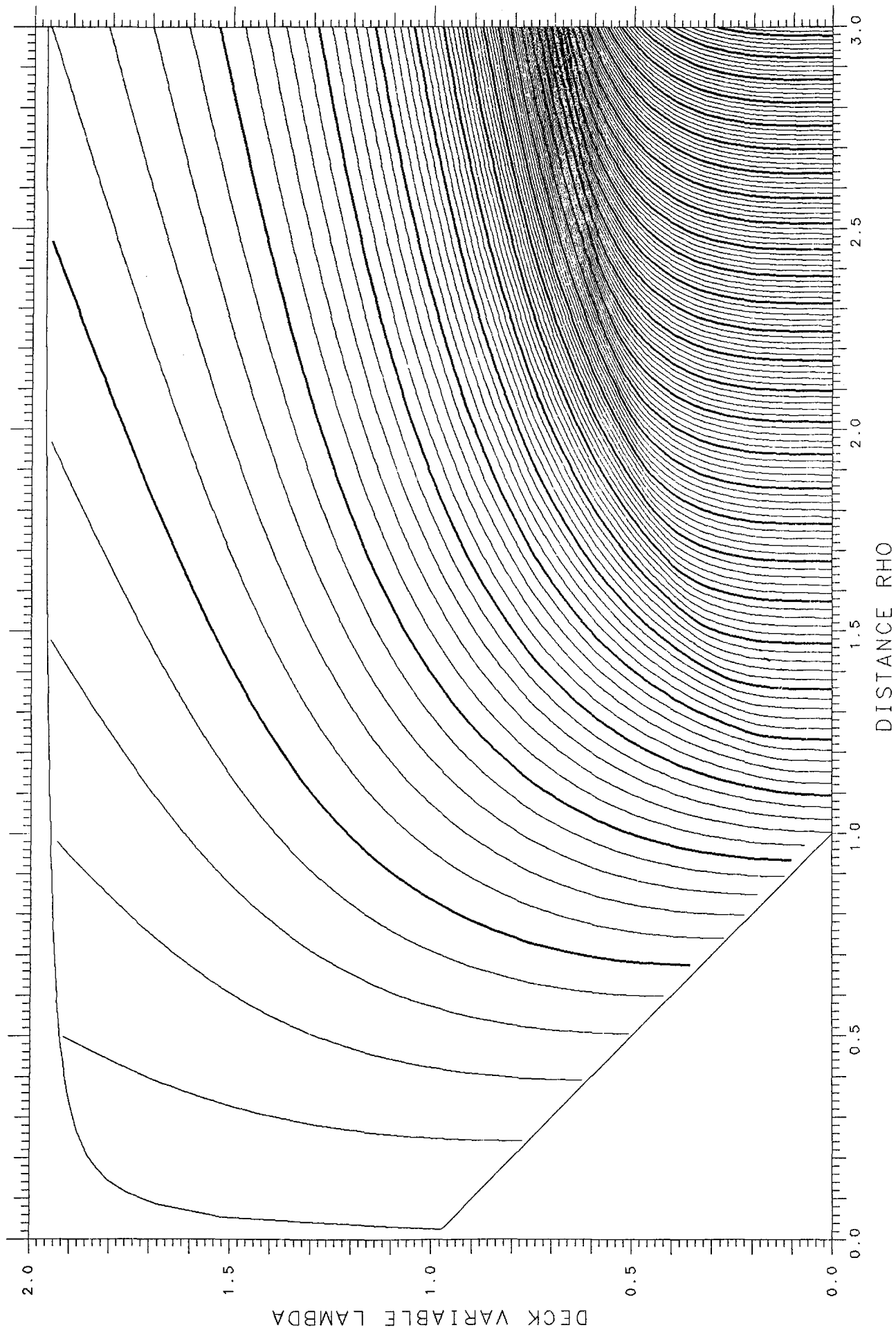

INERTIA PARALLEL ASYMMETRY DELTA= .575

TANGENT .96948 SPACING .01

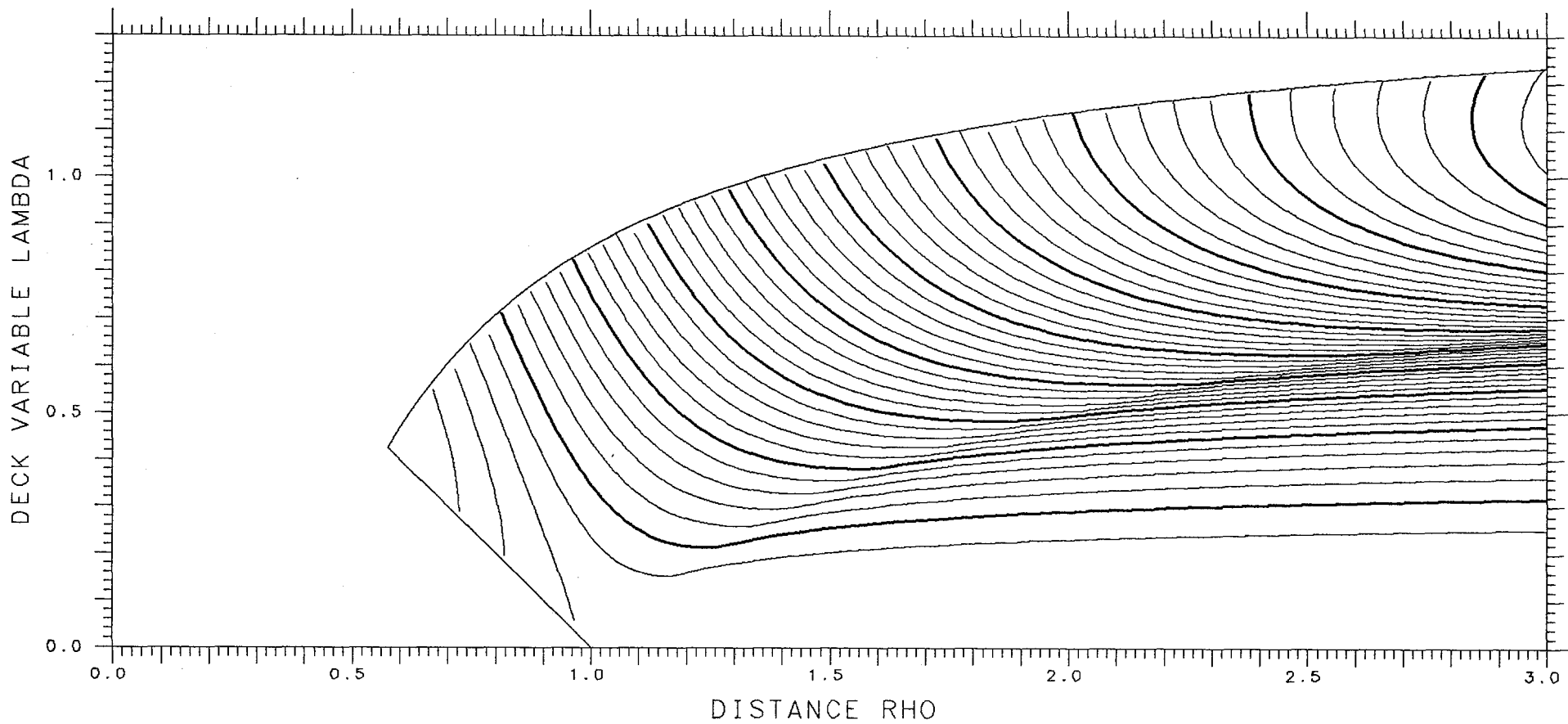

INERTIA PERPENDICULAR ASYMMETRY DELTA= .050

TANGENT 2.17002 SPACING .10

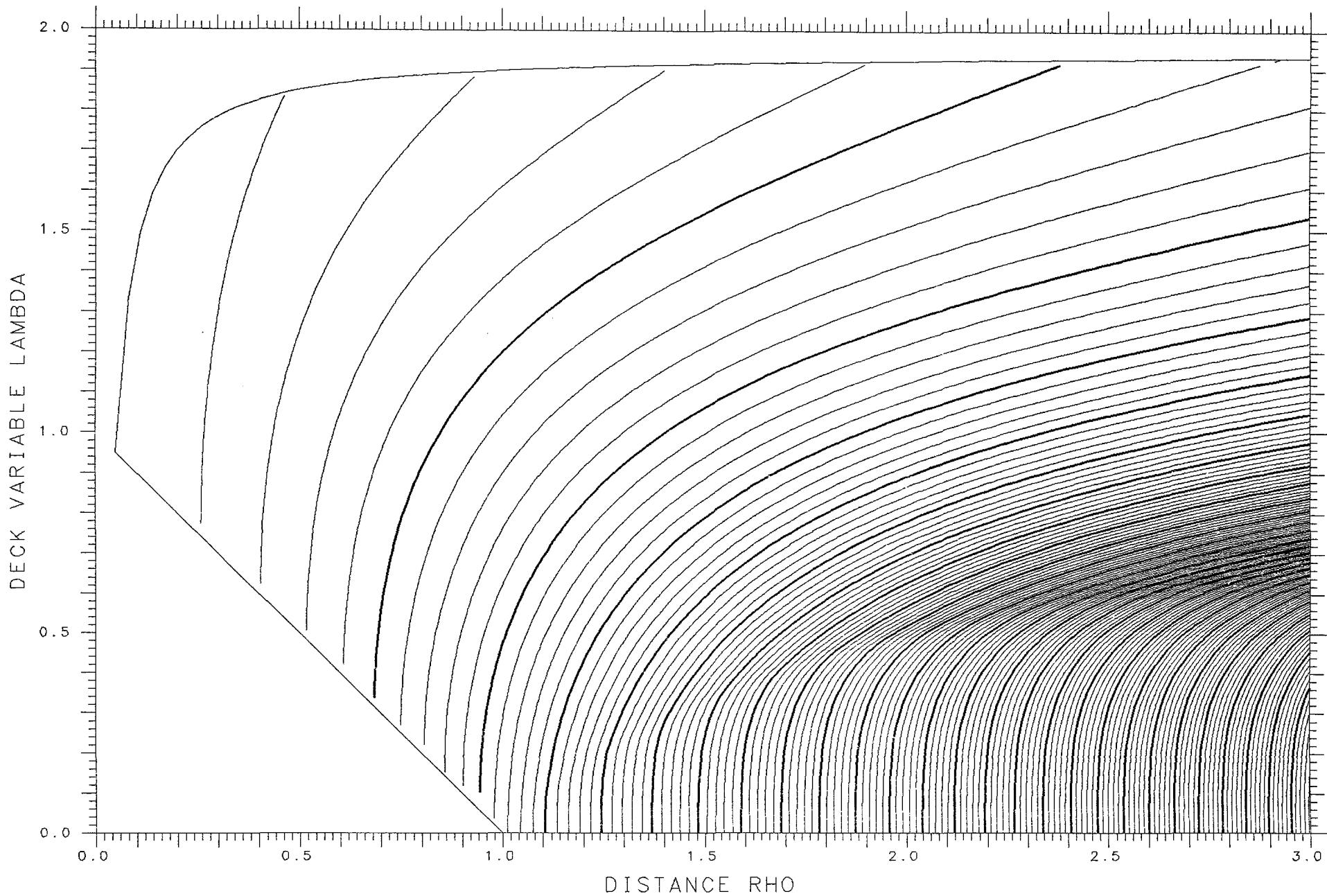

INERTIA PARALLEL ASYMMETRY DELTA = .550

TANGENT .96249 SPACING .01

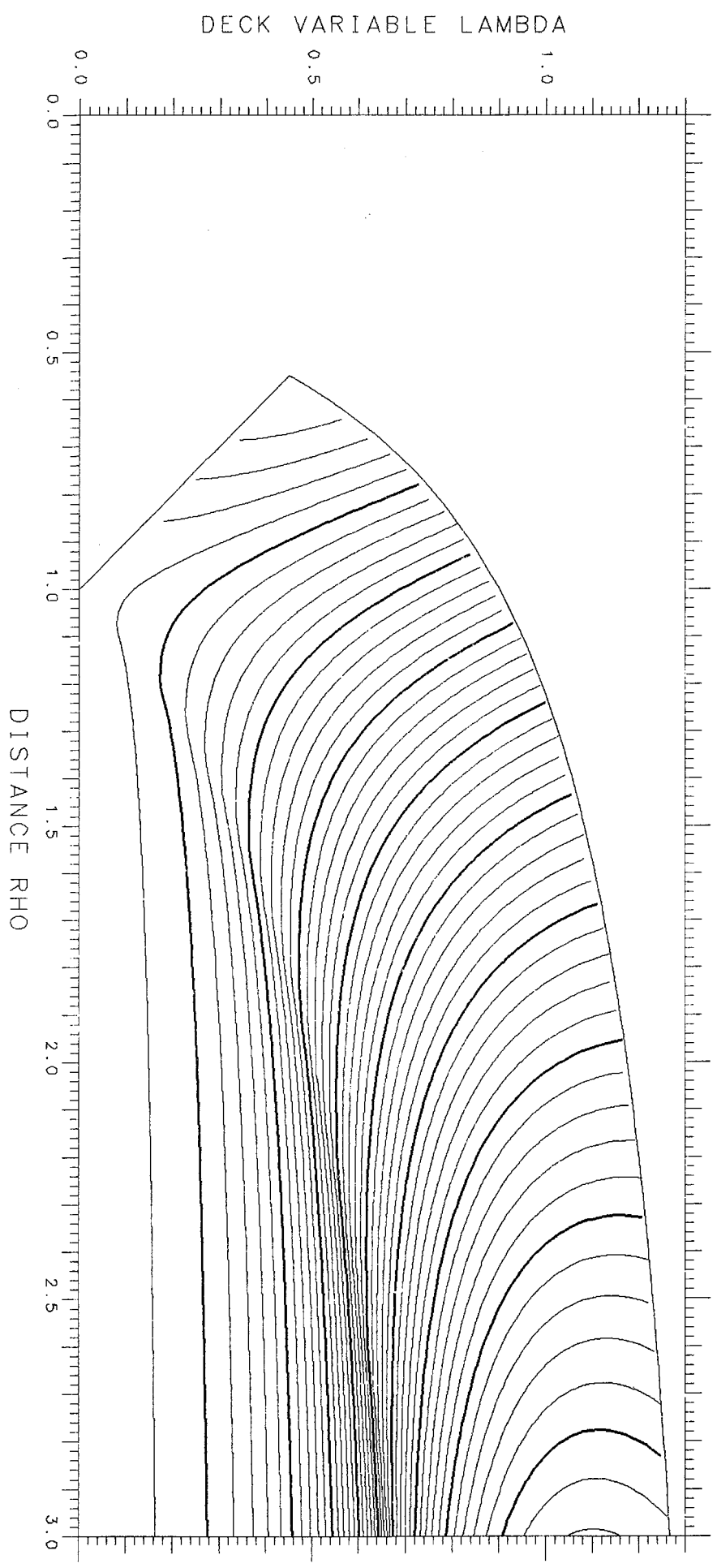

INERTIA PERPENDICULAR ASYMMETRY DELTA= .075

TANGENT 2.12808 SPACING .10

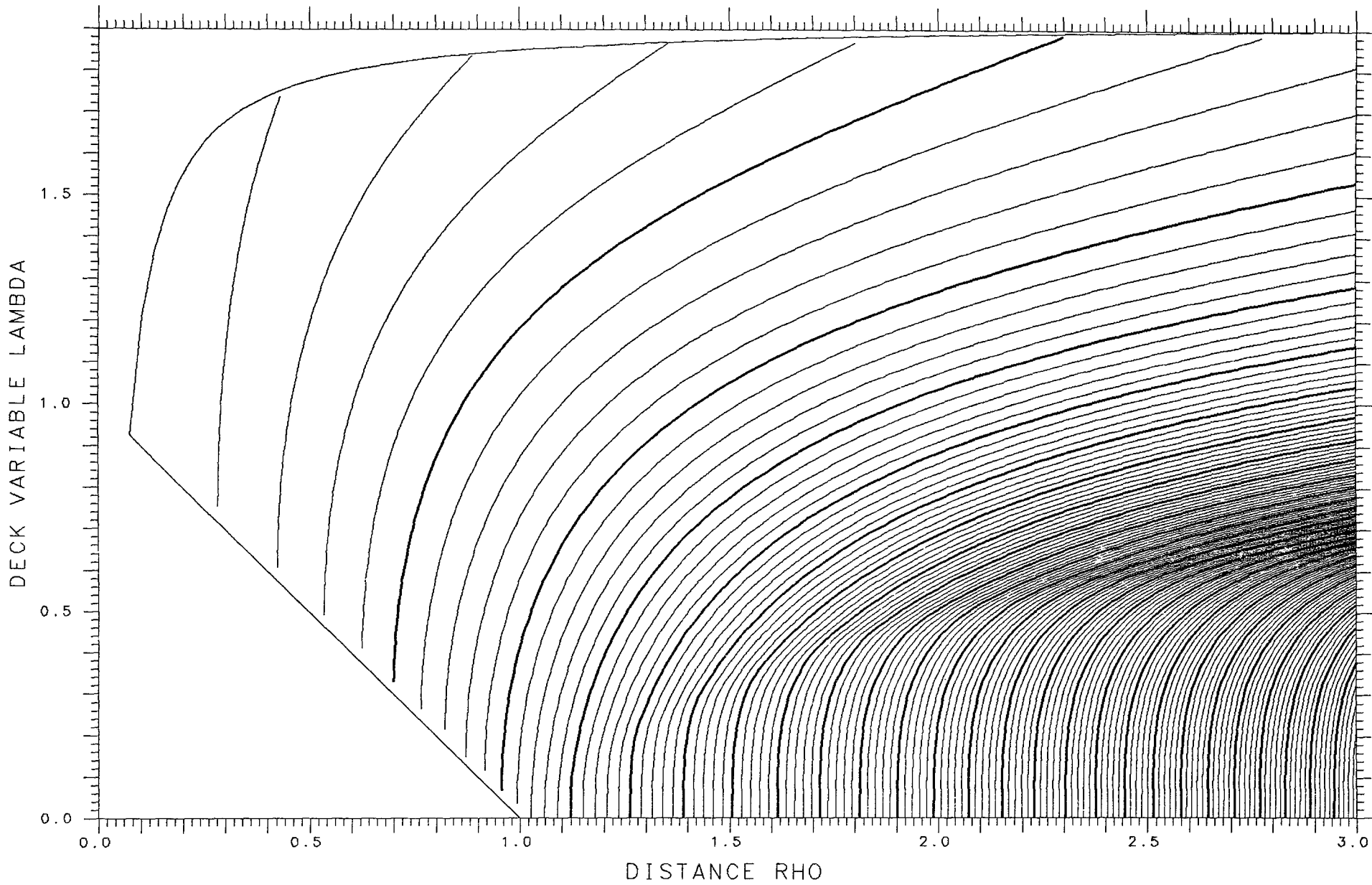

INERTIA PARALLEL ASYMMETRY DELTA = .525

TANGENT .95438 SPACING .01

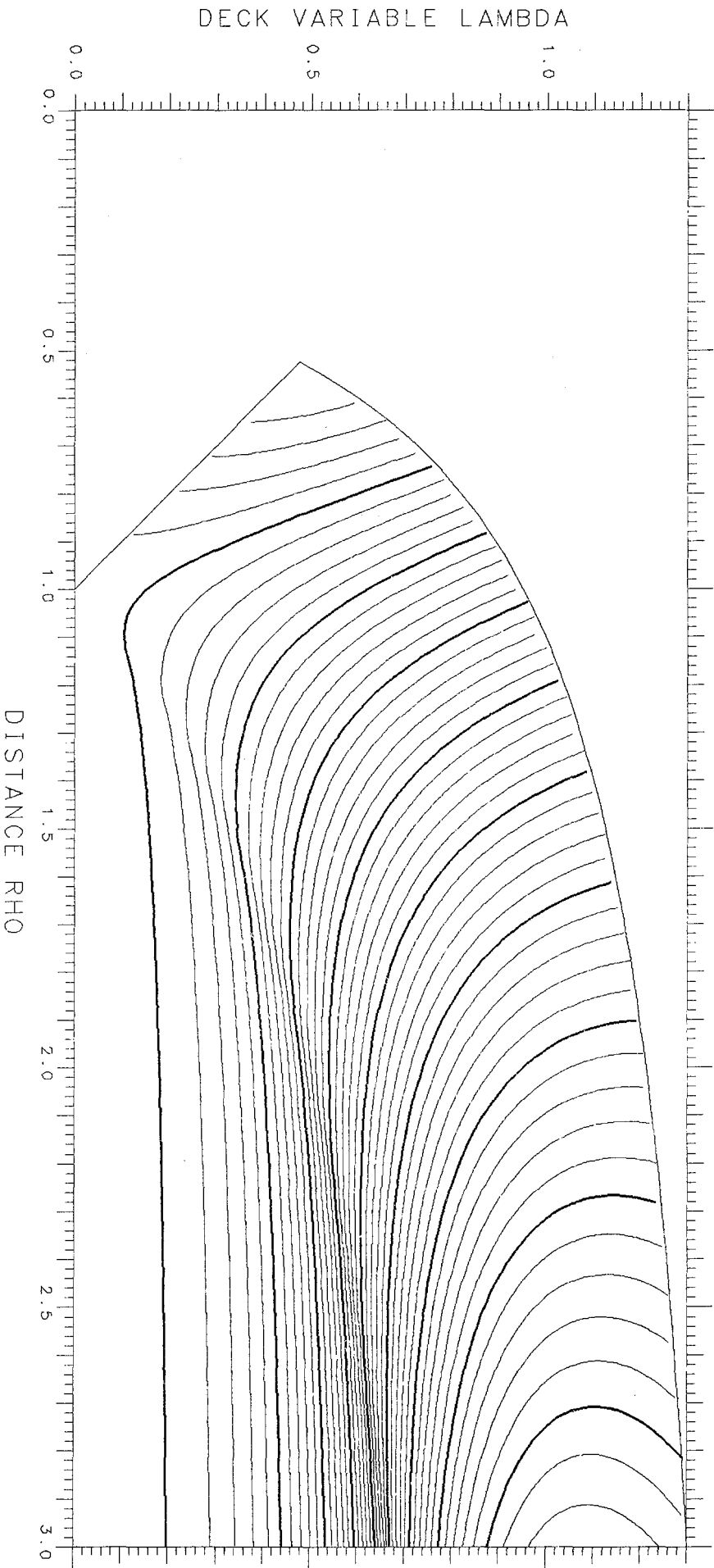

INERTIA PERPENDICULAR ASYMMETRY DELTA= .100

TANGENT 2.07224 SPACING .10

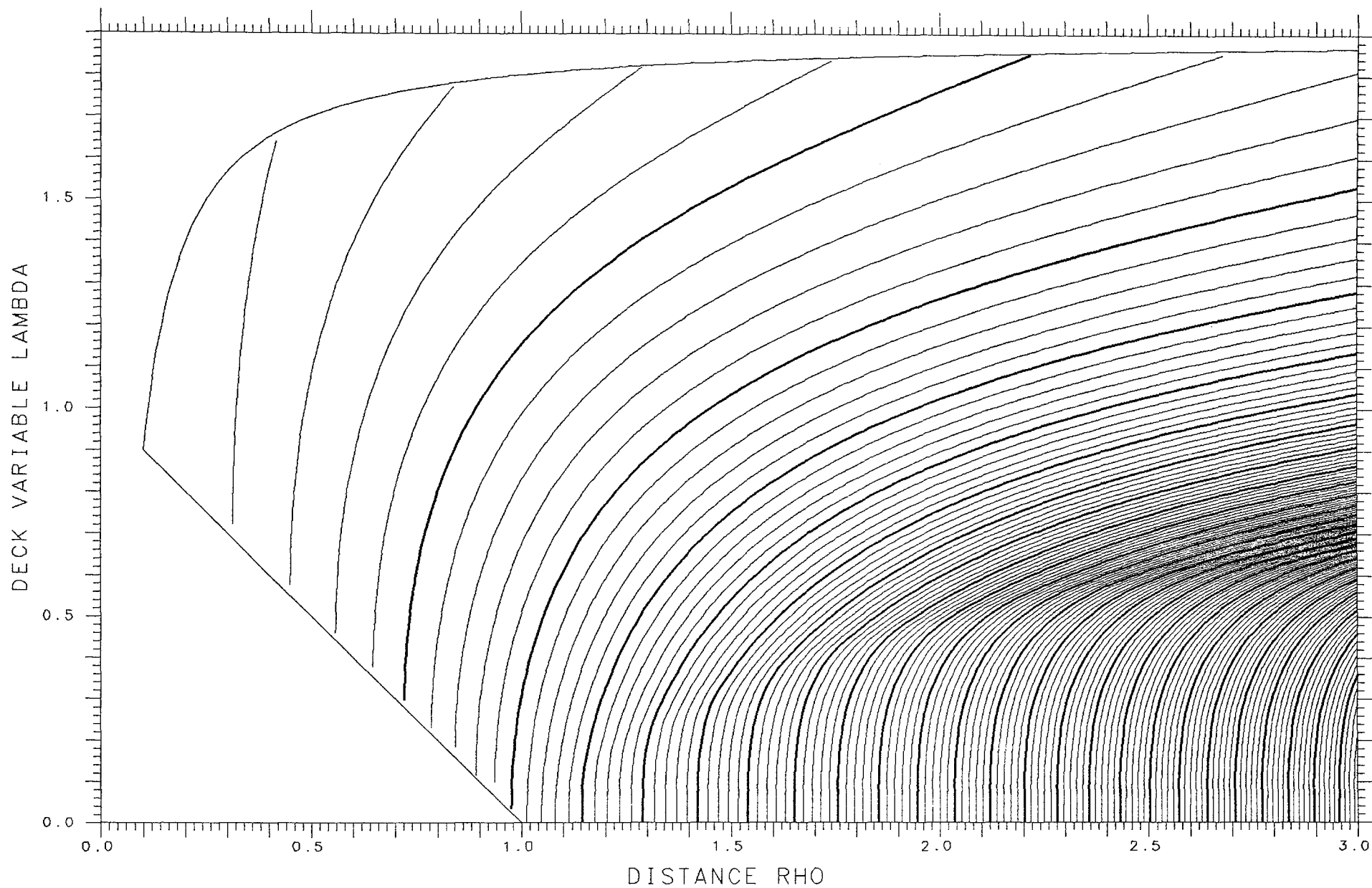

INERTIA PARALLEL ASYMMETRY DELTA= .500

TANGENT .94506 SPACING .01

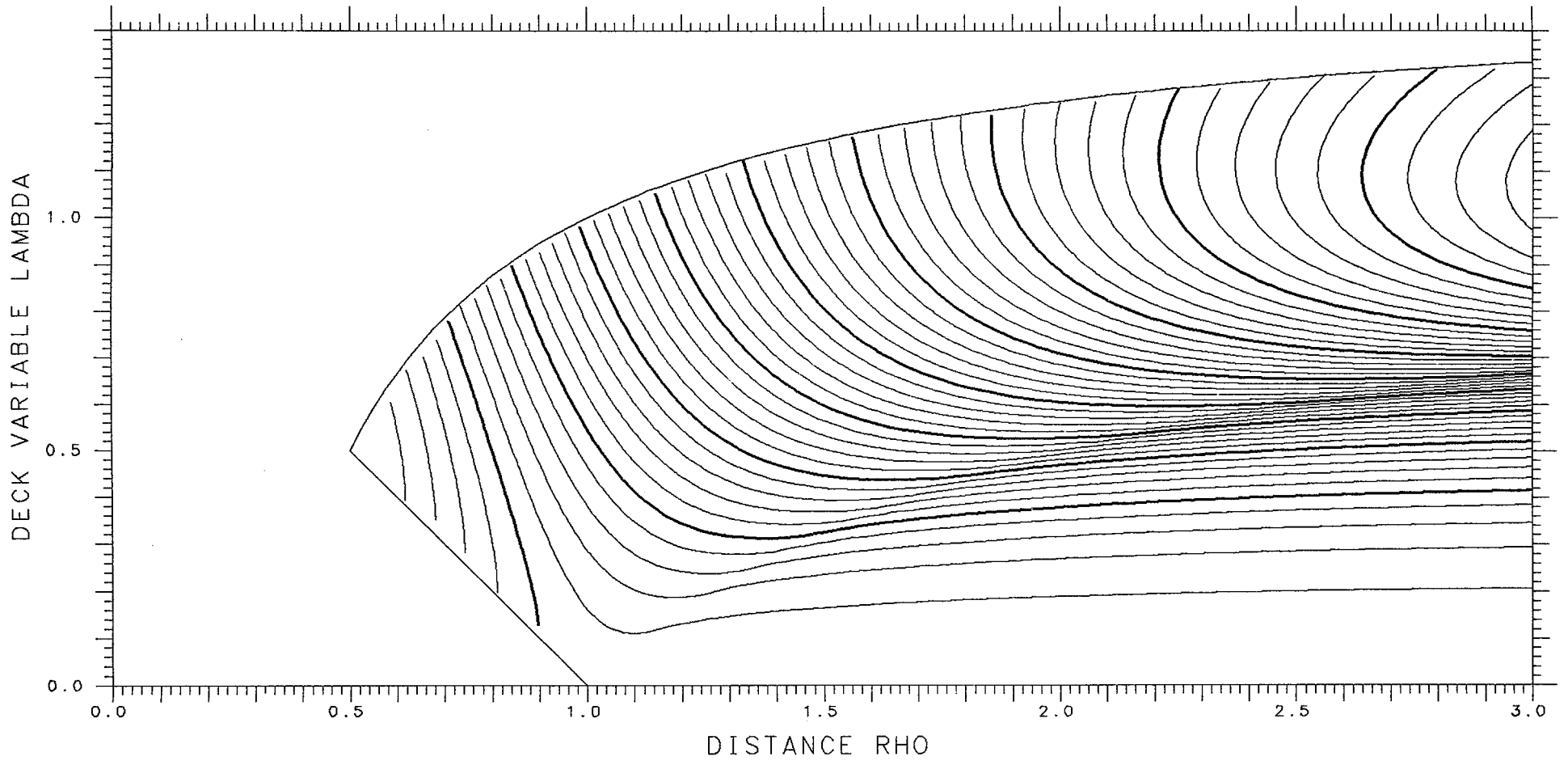

INERTIA PERPENDICULAR ASYMMETRY DELTA= .125

TANGENT 2.00504 SPACING .10

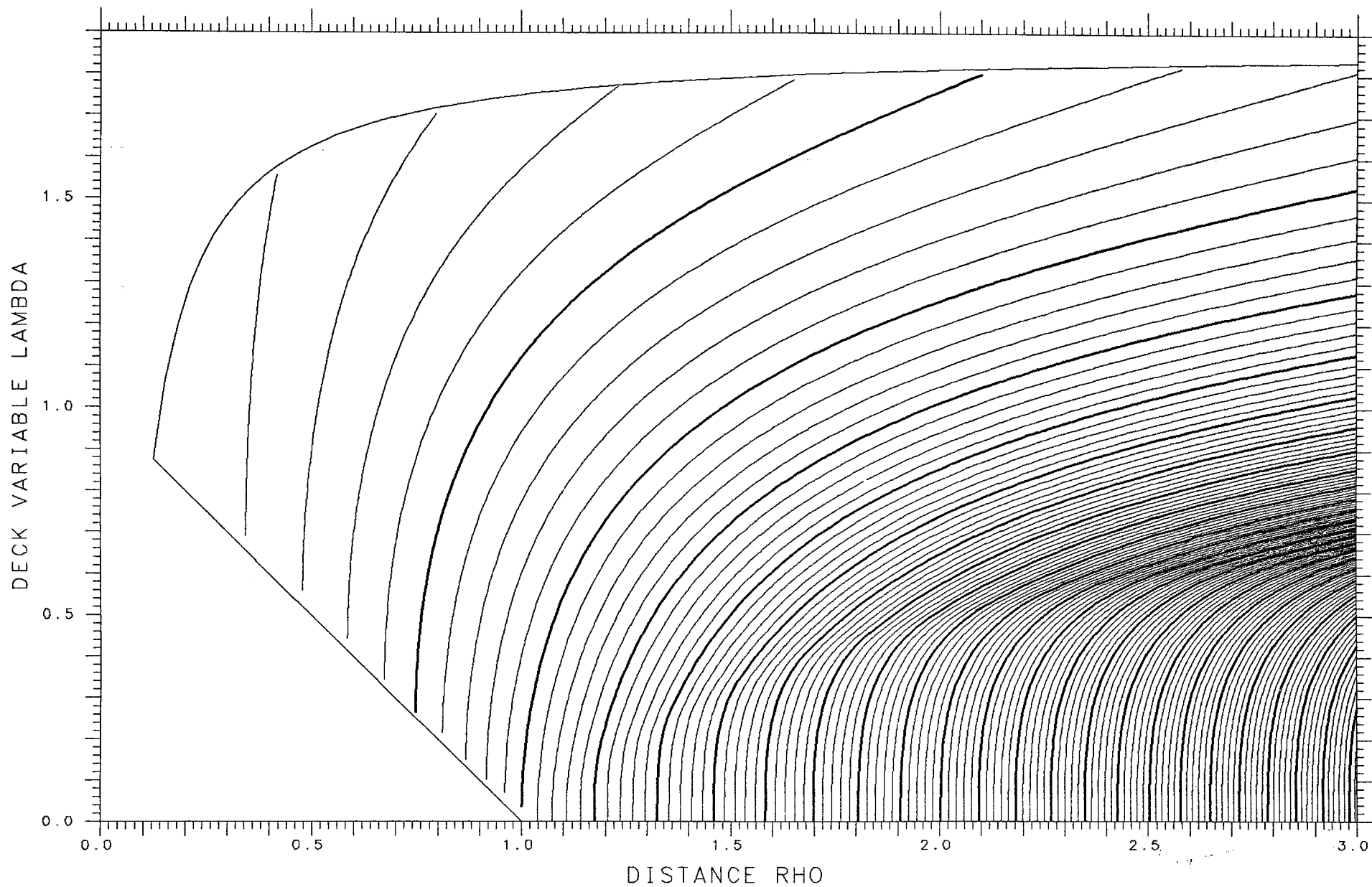

INERTIA PARALLEL ASYMMETRY DELTA= .475

TANGENT .93444 SPACING .01

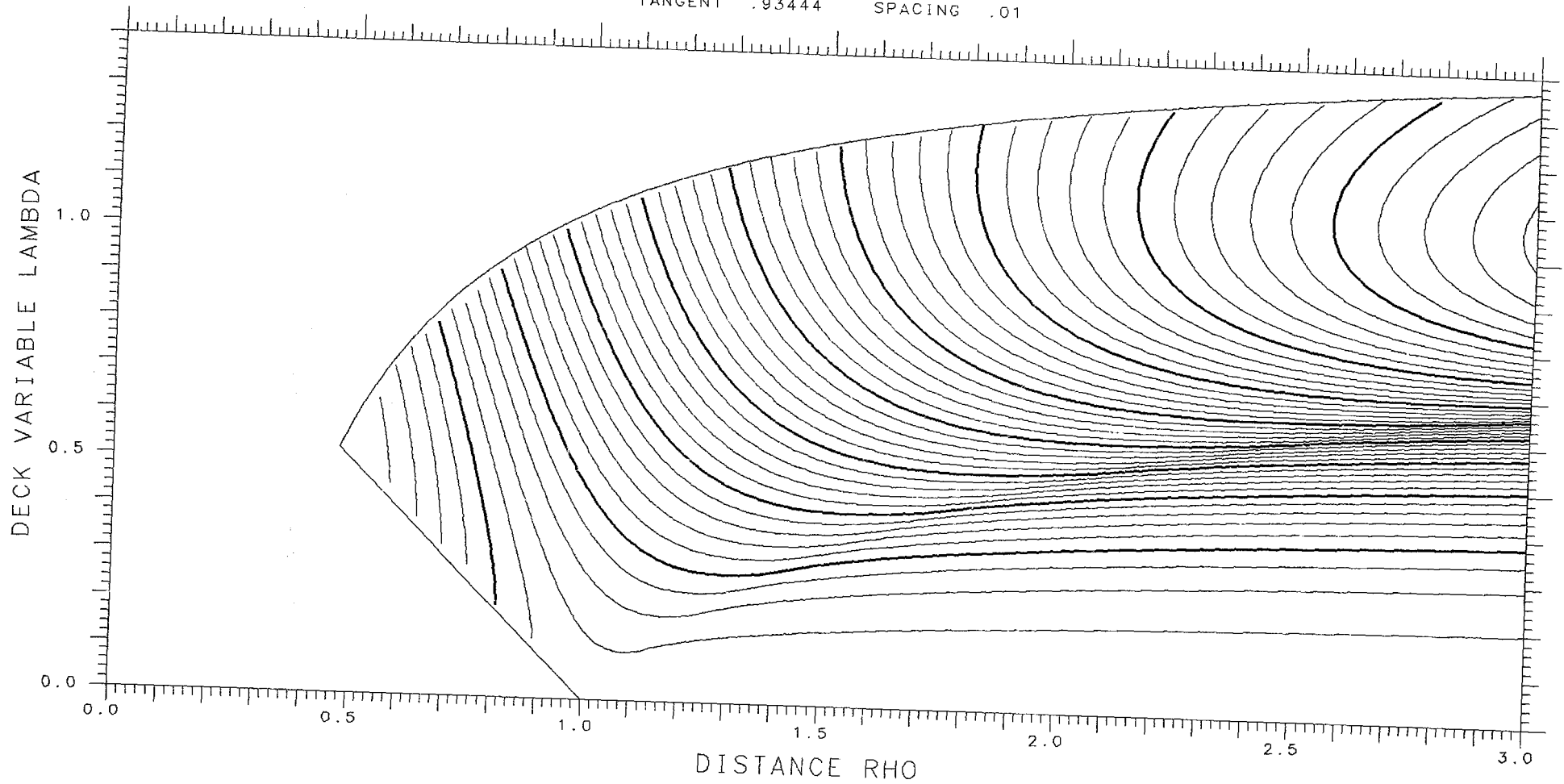

INERTIA PERPENDICULAR ASYMMETRY DELTA= .150

TANGENT 1.92935 SPACING .10

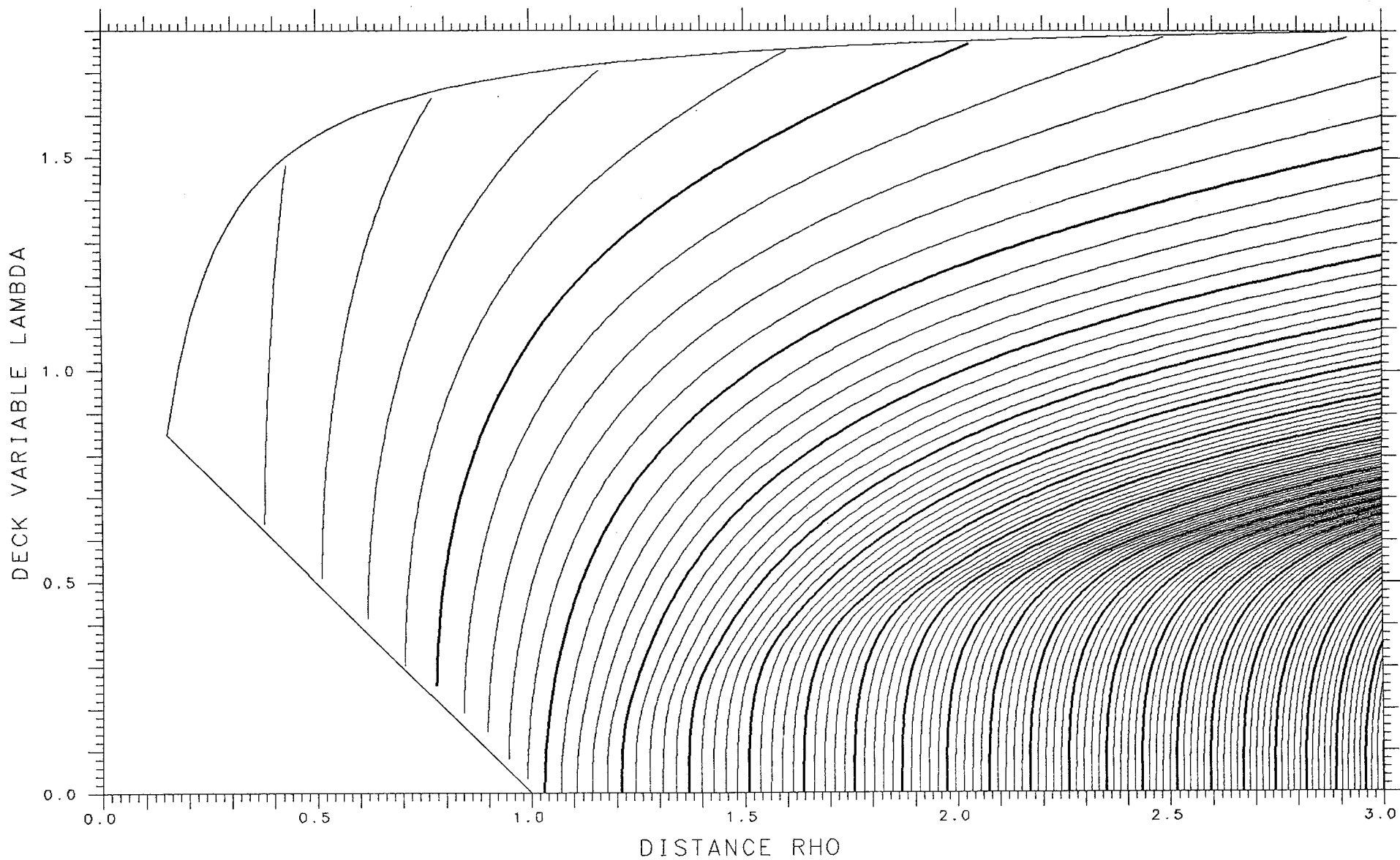

INERTIA PARALLEL ASYMMETRY DELTA= .450

TANGENT .92243 SPACING .01

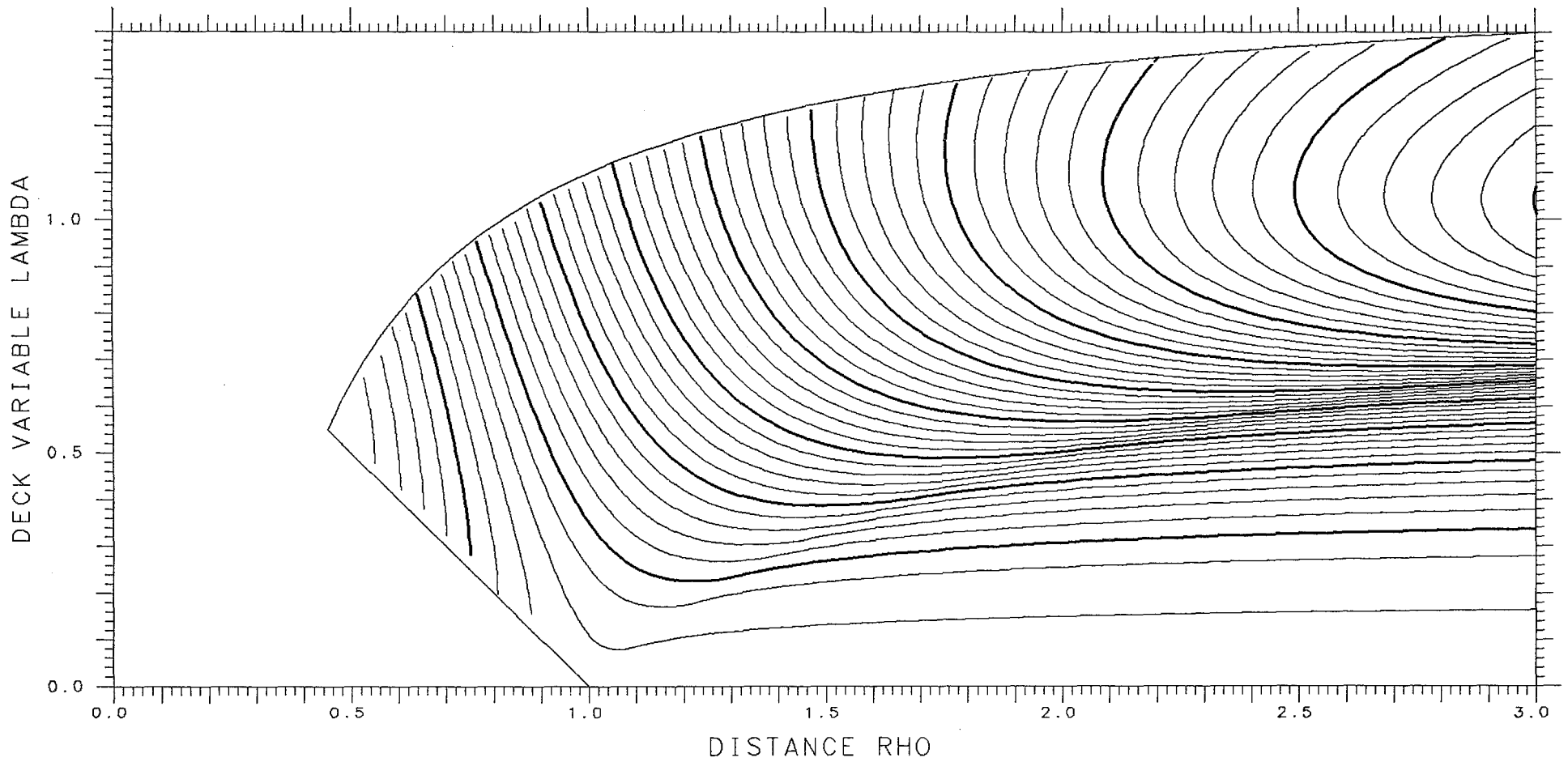

INERTIA PERPENDICULAR ASYMMETRY DELTA= .175

TANGENT 1.84814 SPACING .10

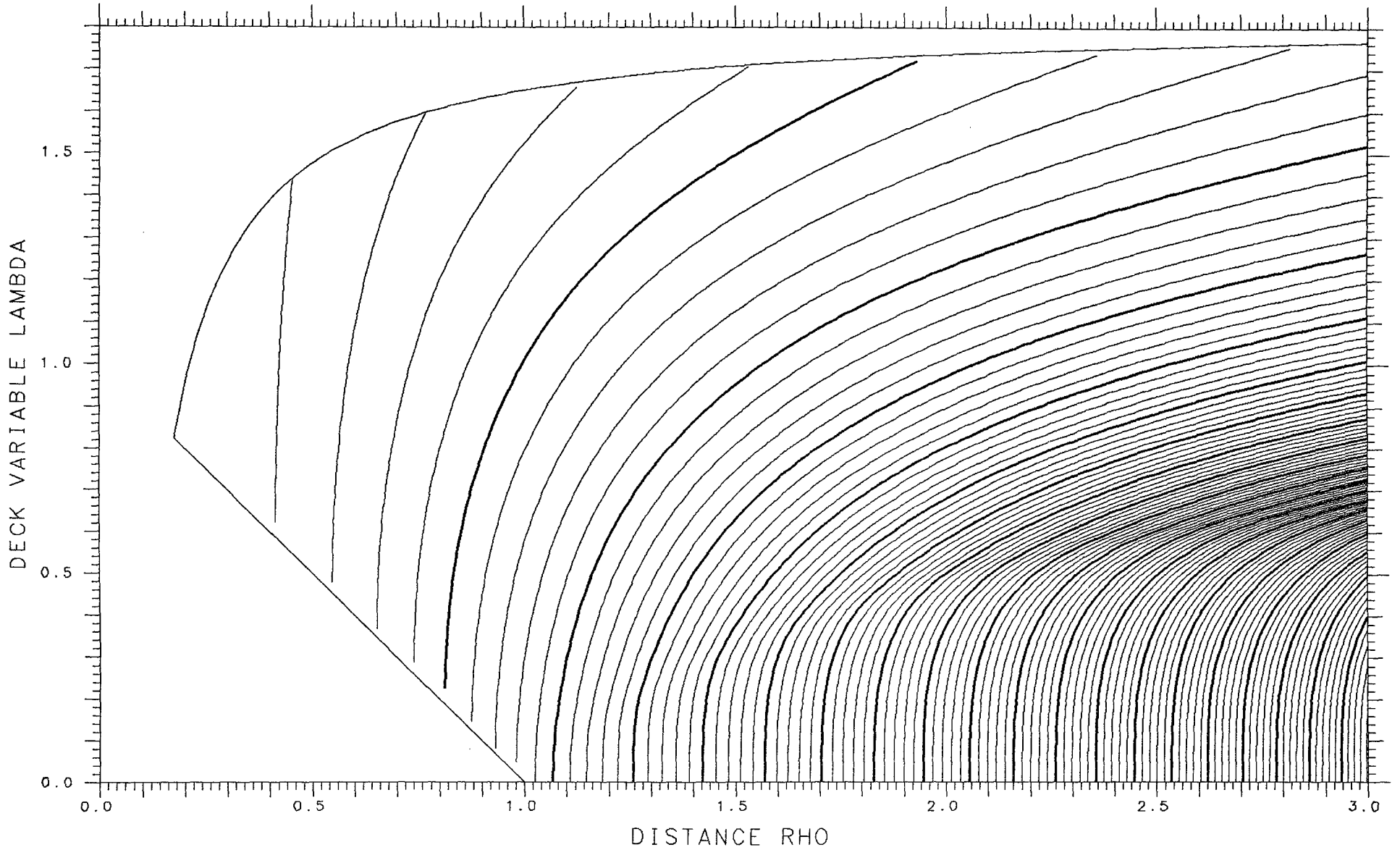

INERTIA PARALLEL ASYMMETRY DELTA = .425

TANGENT .90900 SPACING .01

DECK VARIABLE LAMBDA

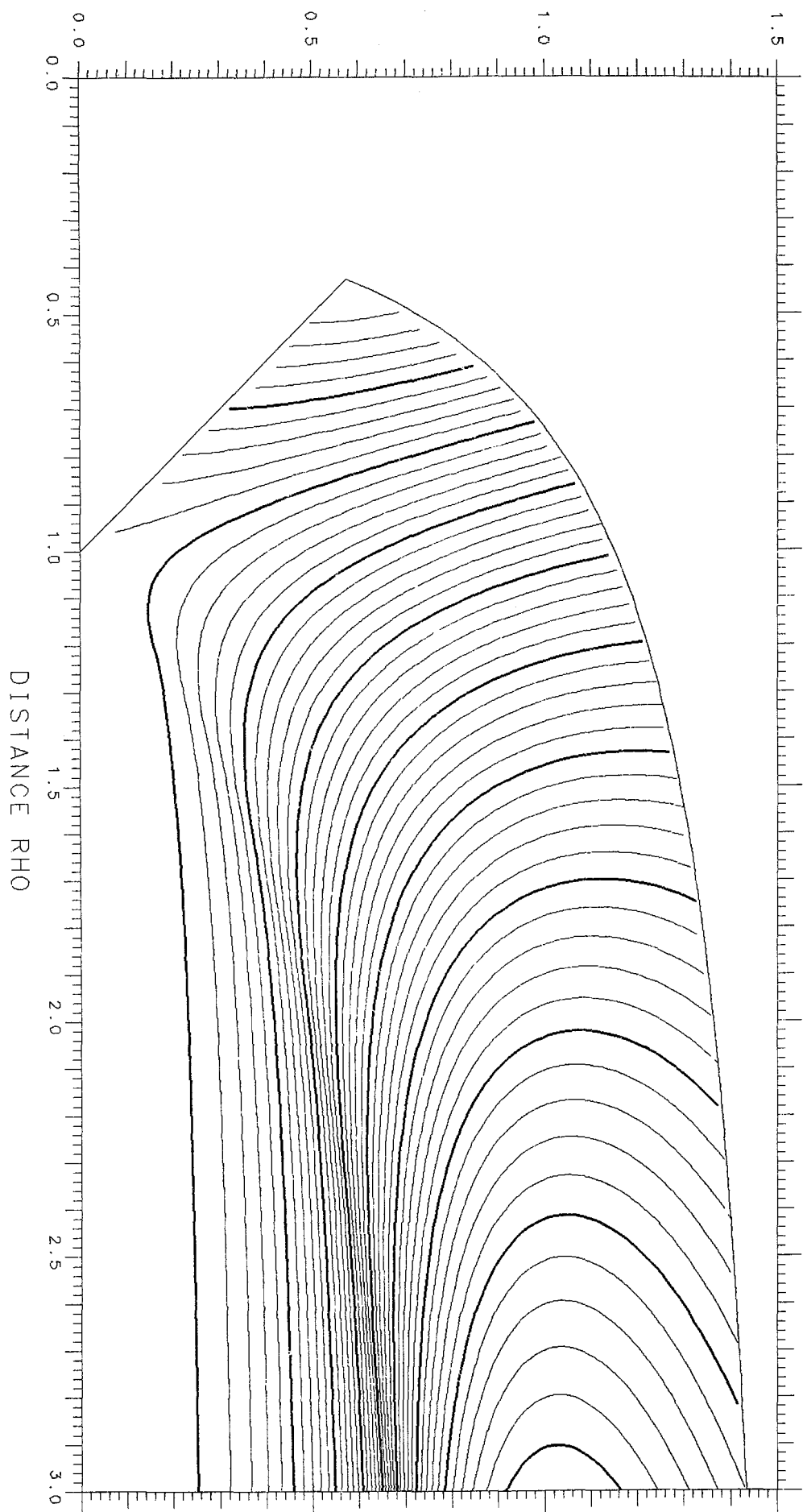

INERTIA PERPENDICULAR ASYMMETRY DELTA= .200

TANGENT 1.76428 SPACING .10

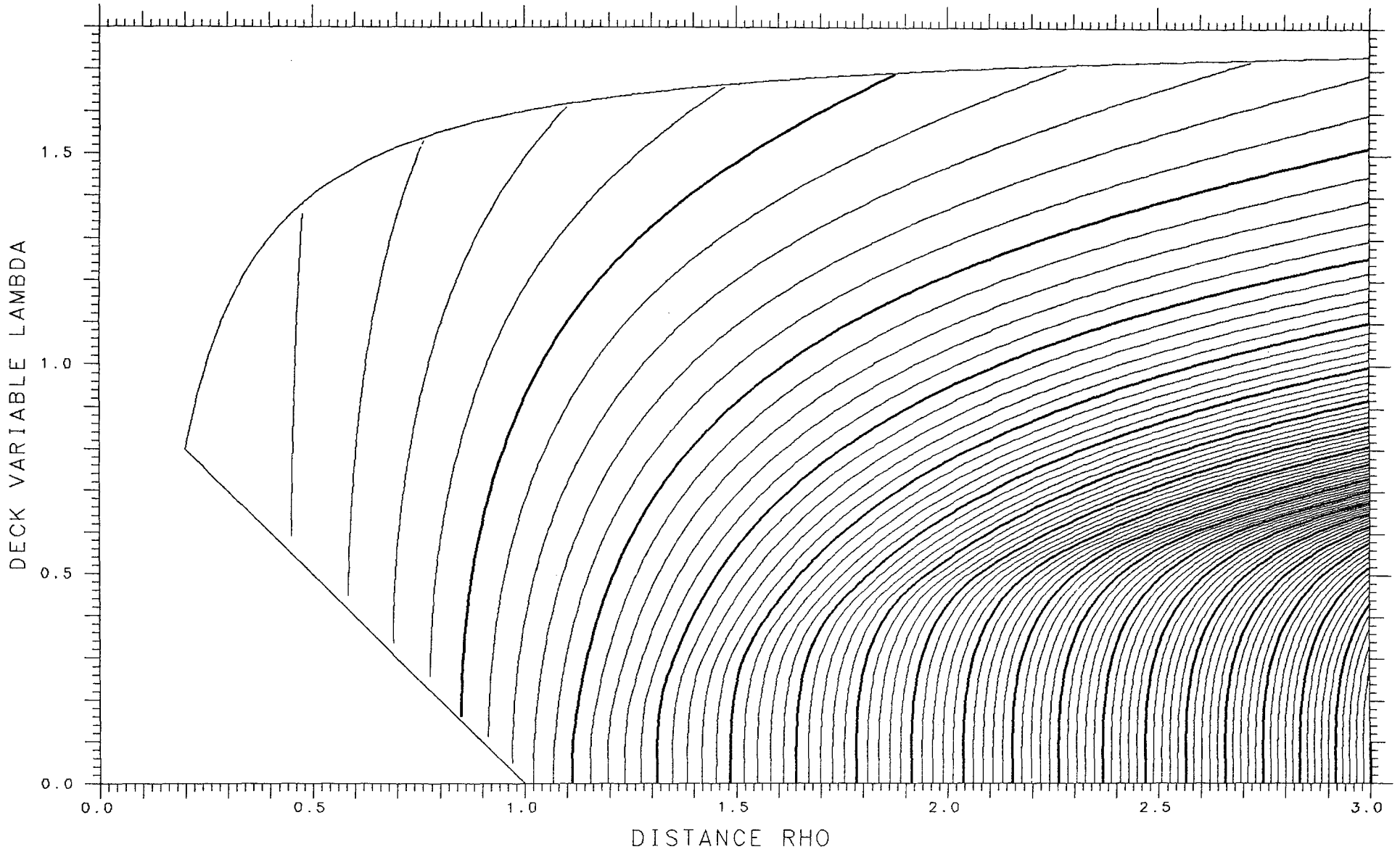

INERTIA PARALLEL ASYMMETRY DELTA= .400

TANGENT .89410 SPACING .01

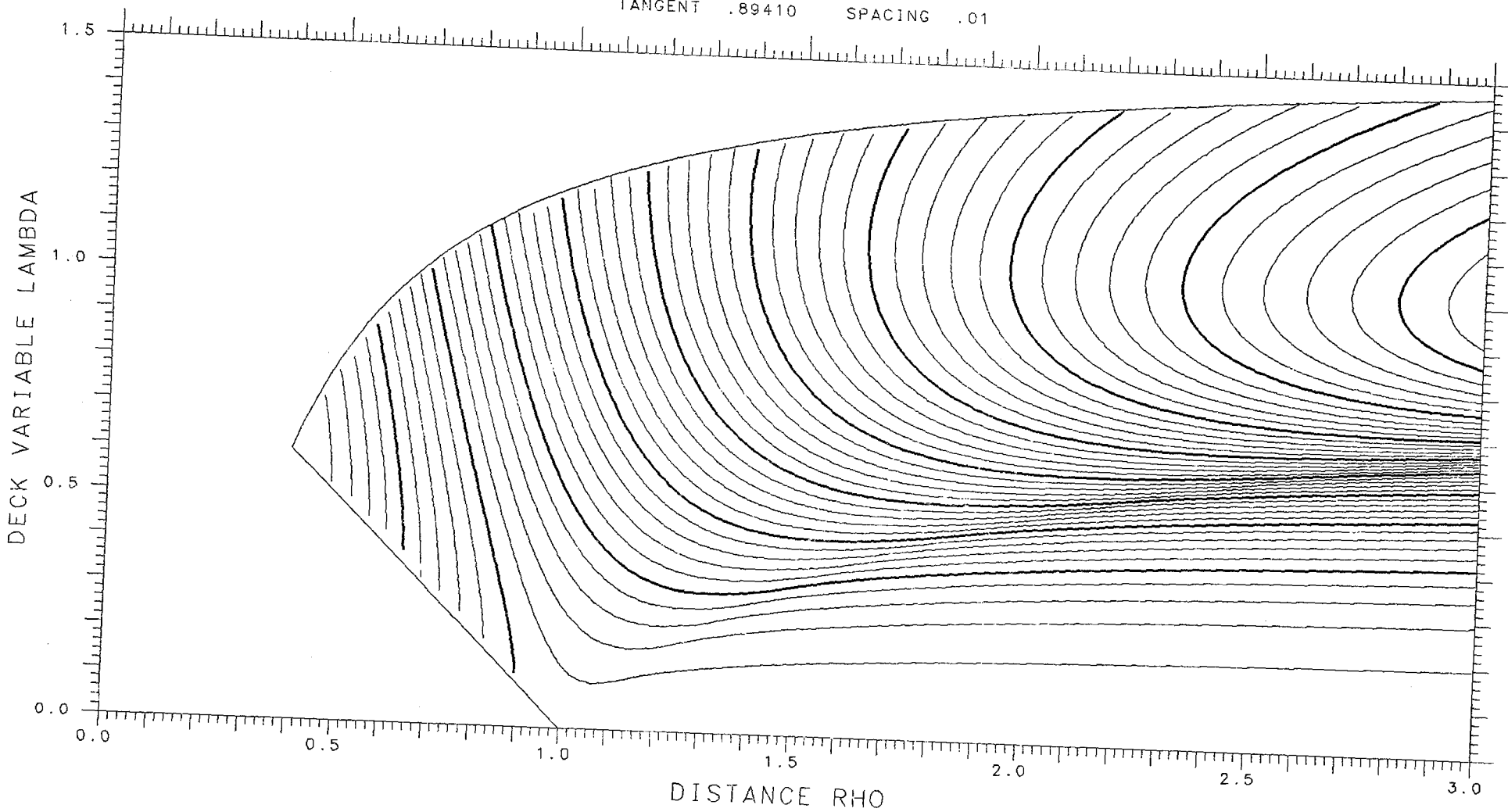

INERTIA PERPENDICULAR ASYMMETRY DELTA= .225

TANGENT 1.68036 SPACING .10

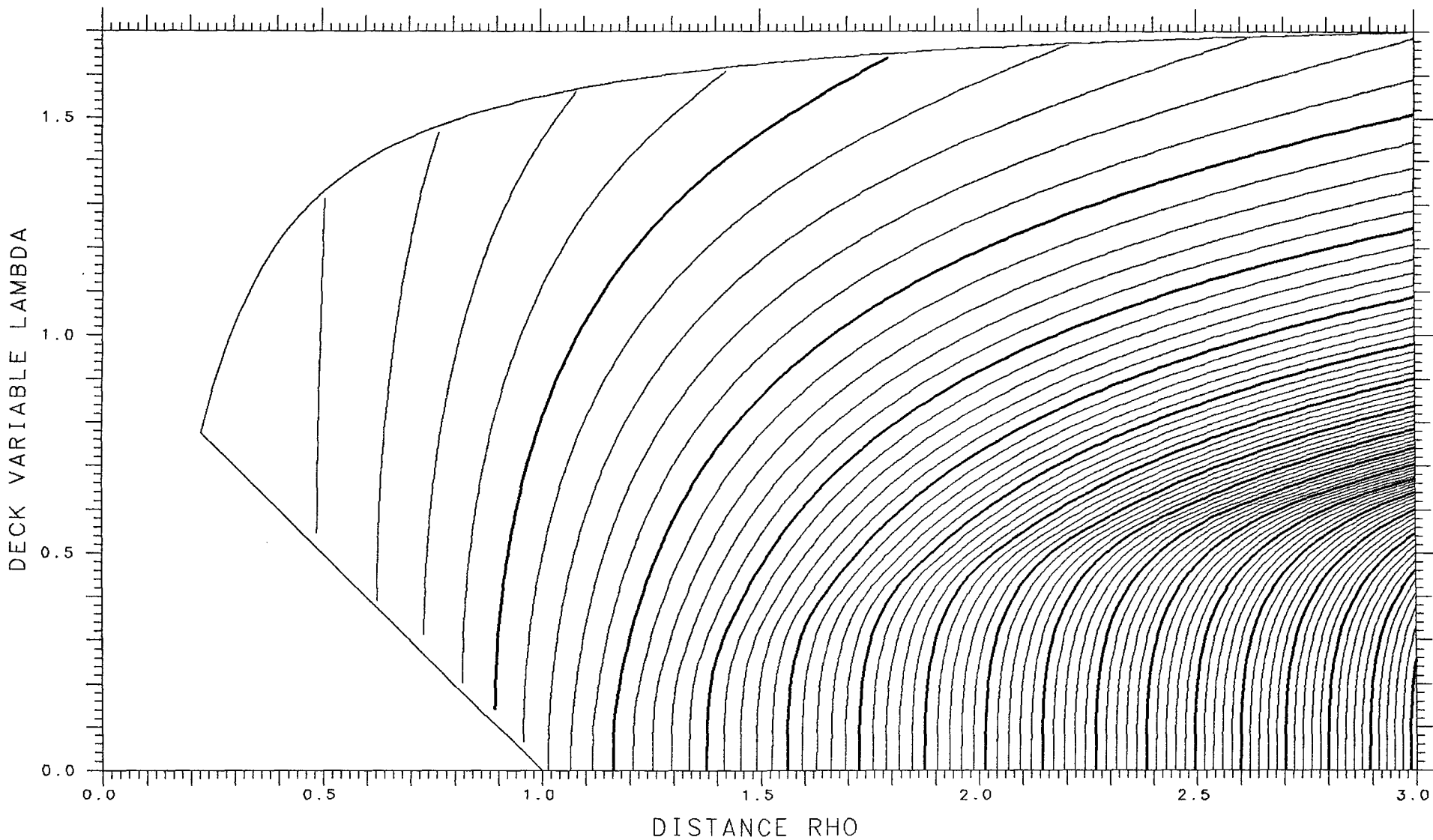

INERTIA PARALLEL ASYMMETRY DELTA= .375

TANGENT .87776 SPACING .01

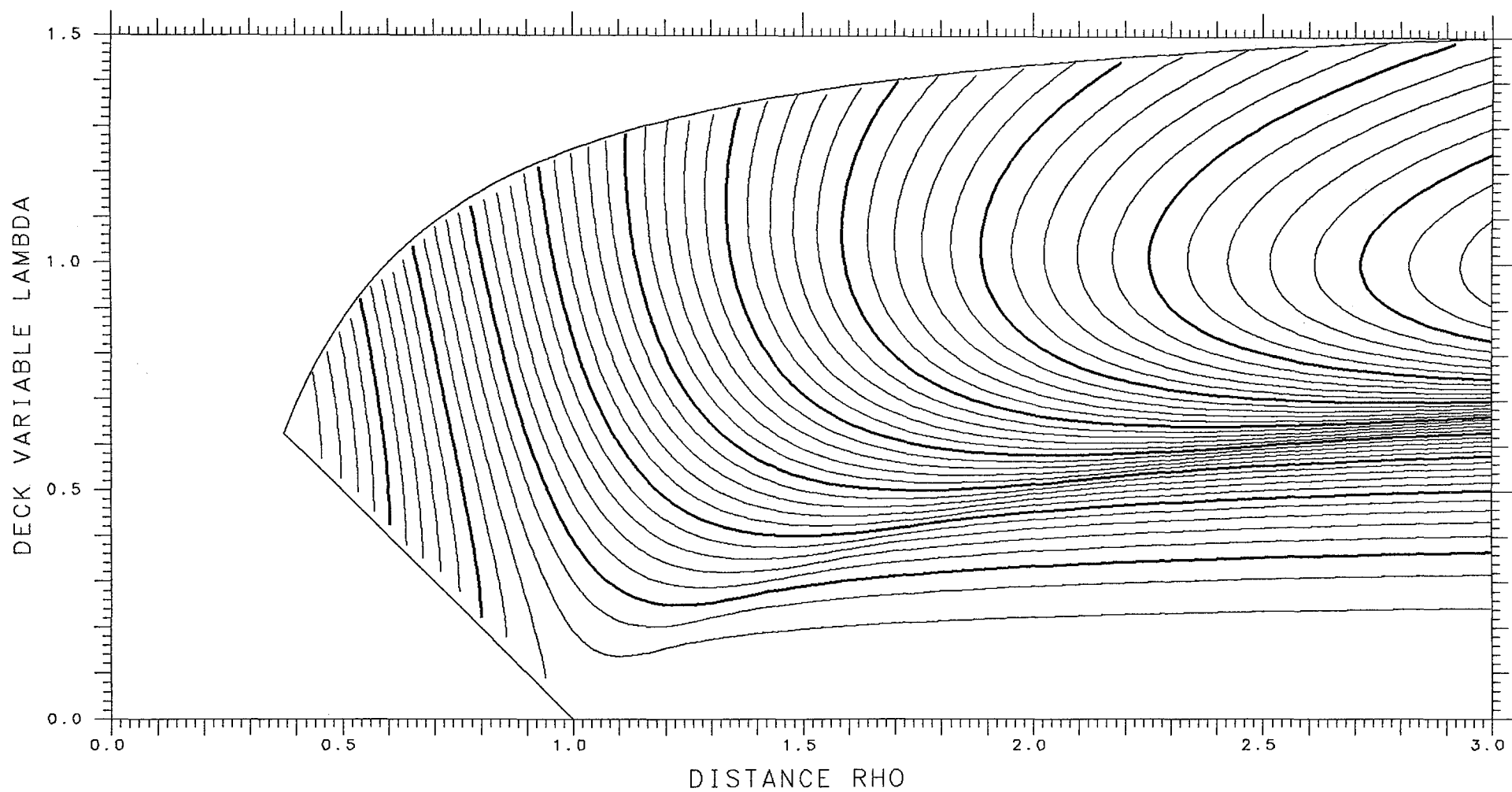

INERTIA PERPENDICULAR ASYMMETRY DELTA= .250

TANGENT 1.59860 SPACING .10

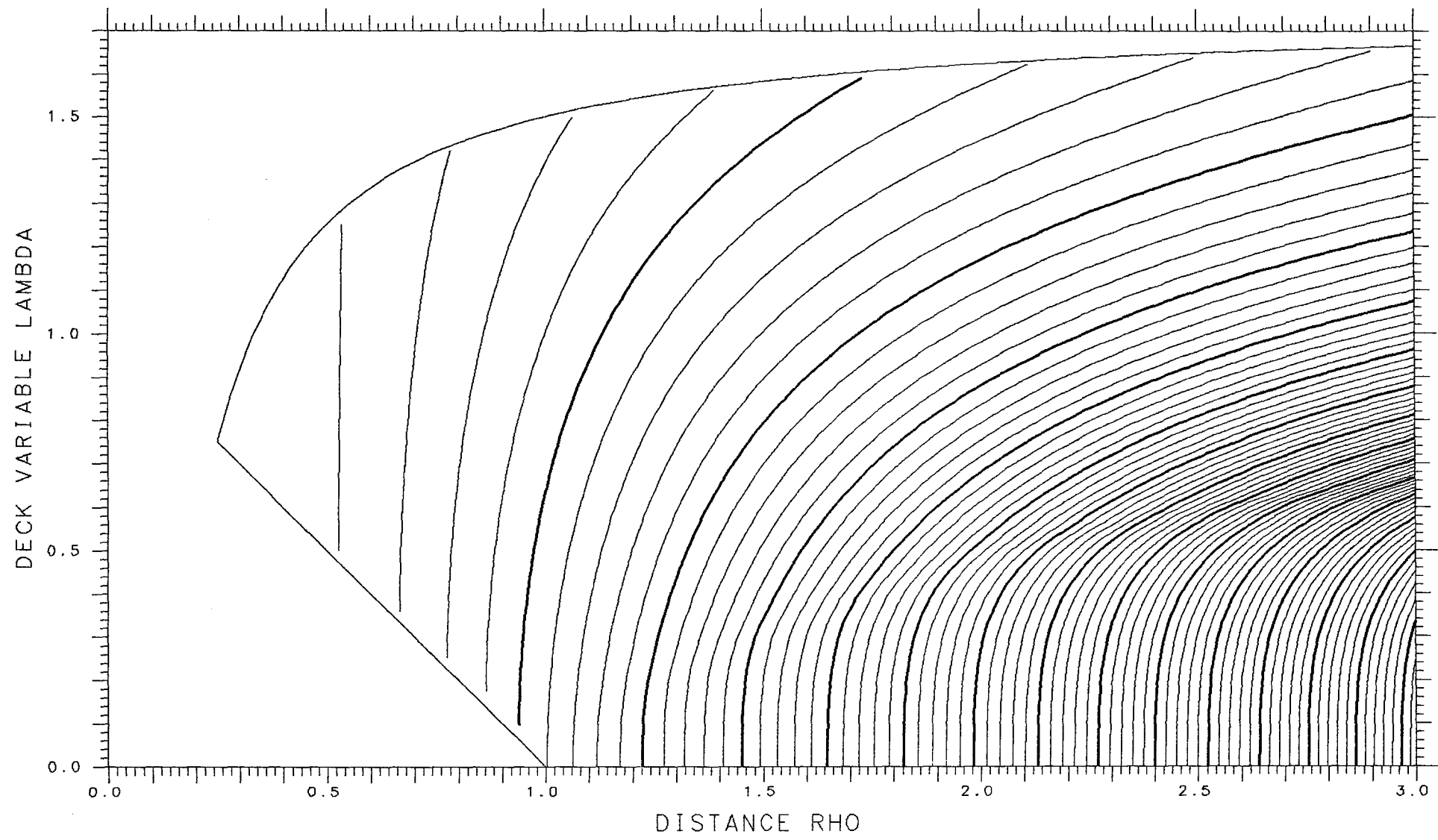

INERTIA PARALLEL ASYMMETRY DELTA= .350

TANGENT .86001 SPACING .01

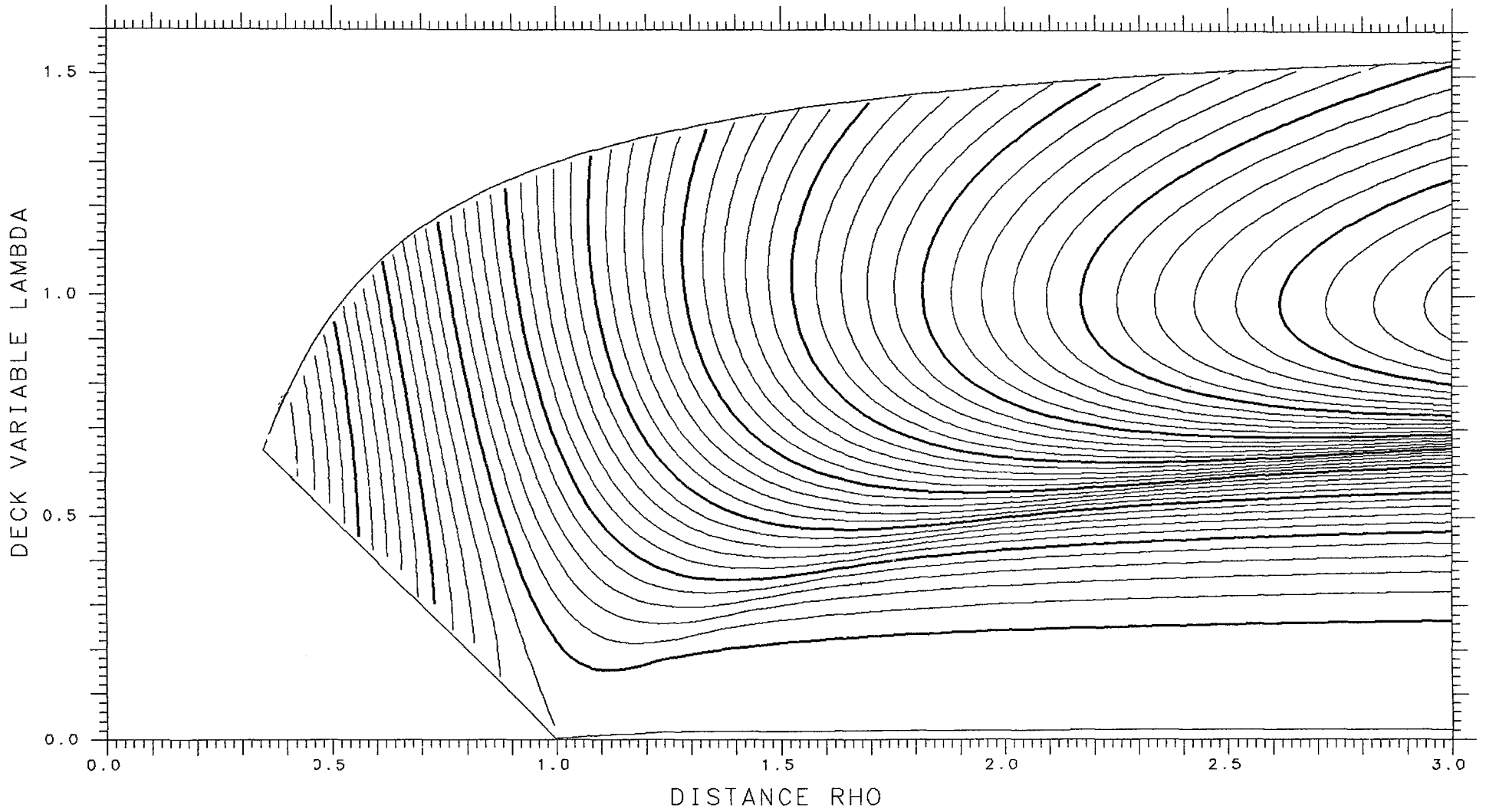

INERTIA PERPENDICULAR ASYMMETRY DELTA= .275

TANGENT 1.52078 SPACING .10

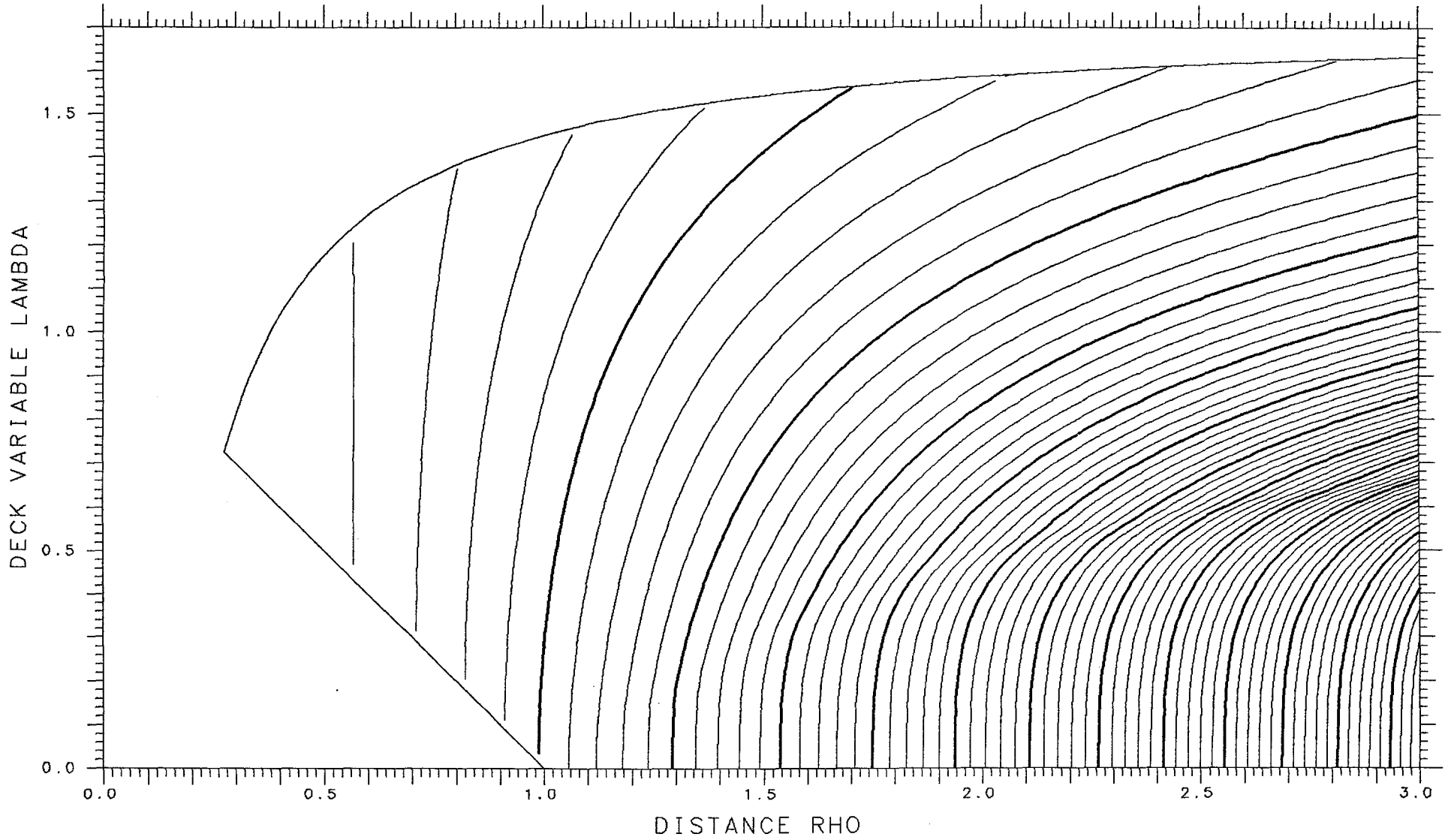

INERTIA PARALLEL ASYMMETRY DELTA= .325

TANGENT .84096 SPACING .01

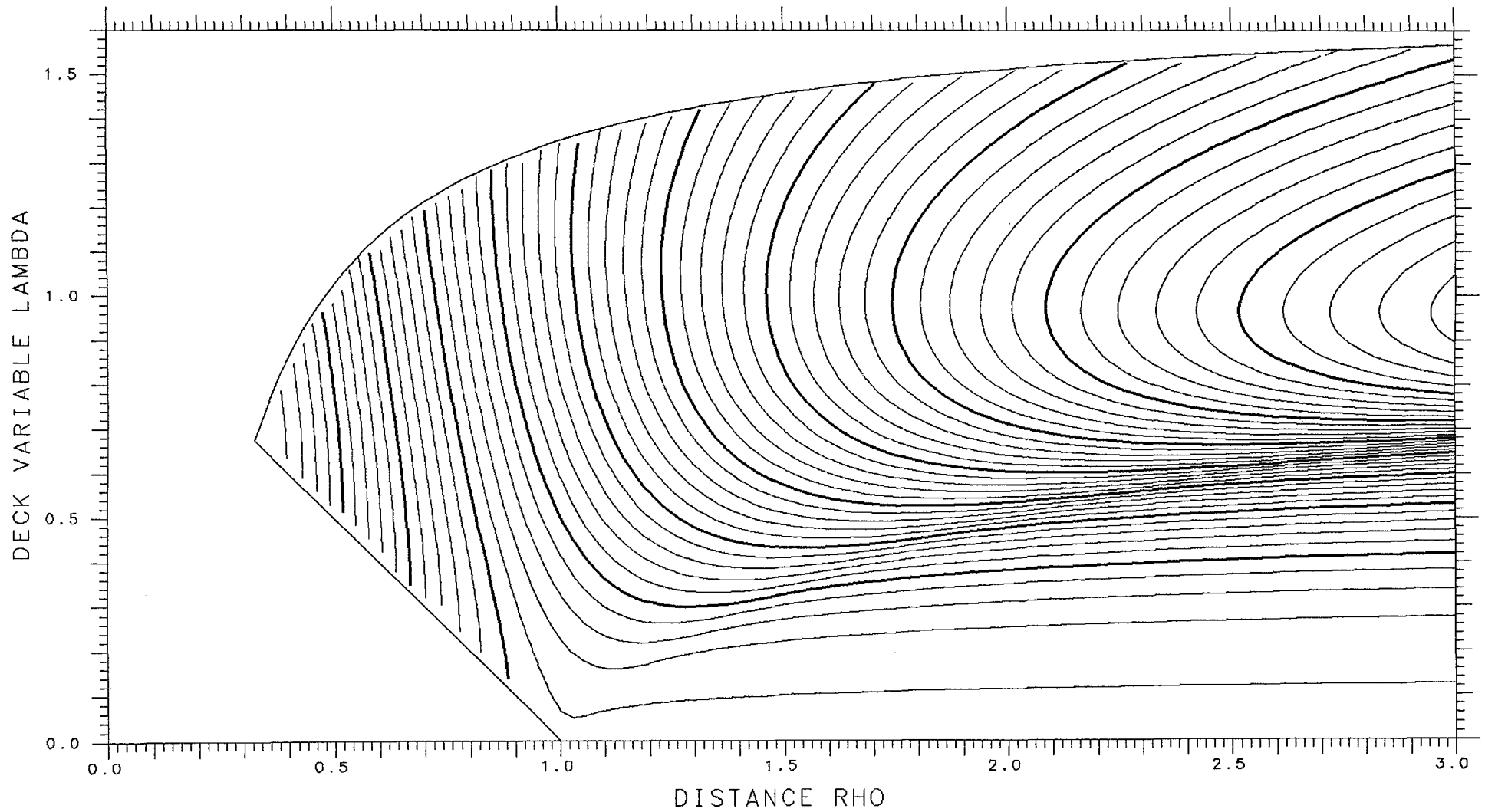

INERTIA PERPENDICULAR ASYMMETRY DELTA= .300

TANGENT 1.44820 SPACING .05

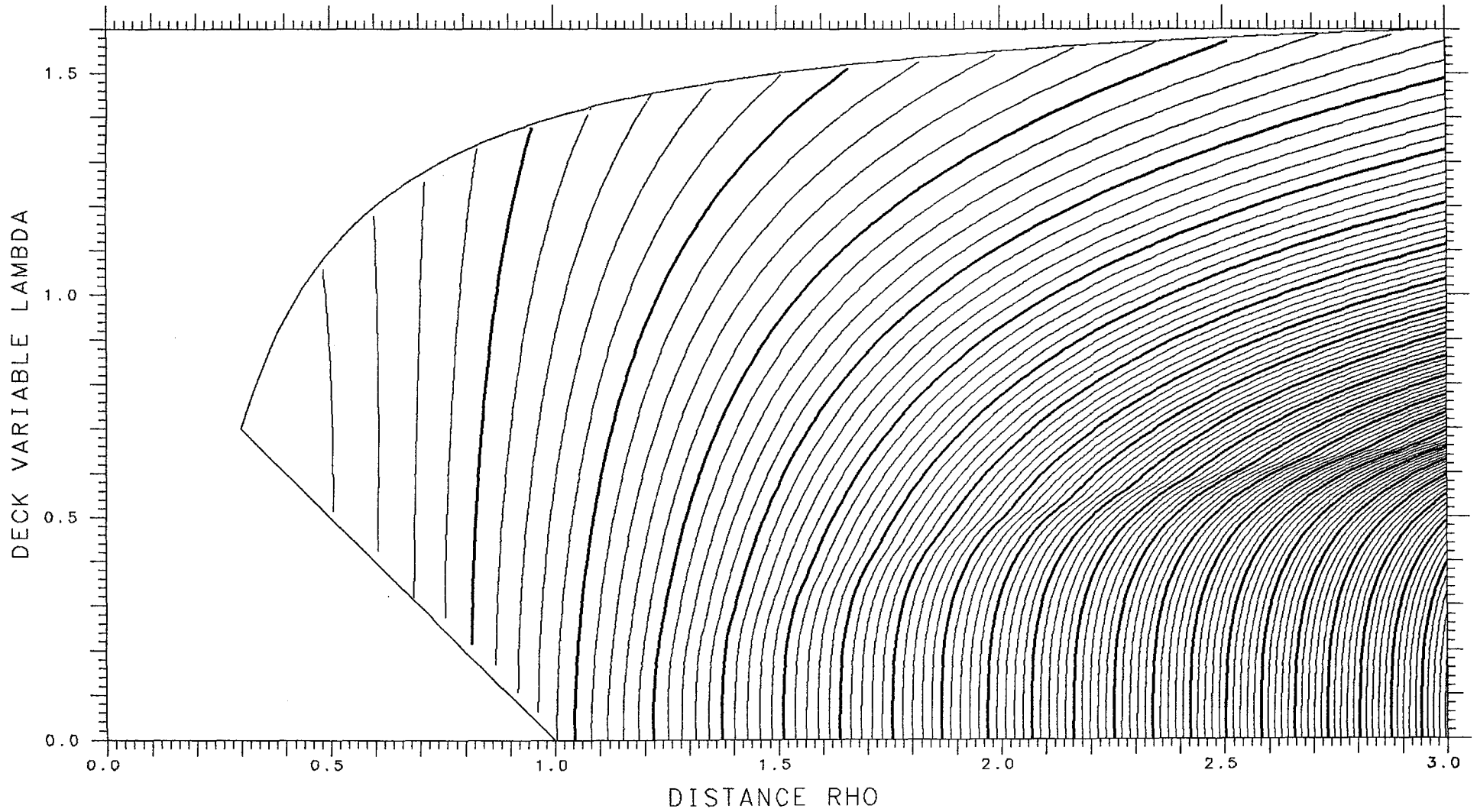

INERTIA PARALLEL ASYMMETRY DELTA= .300

TANGENT .82077 SPACING .01

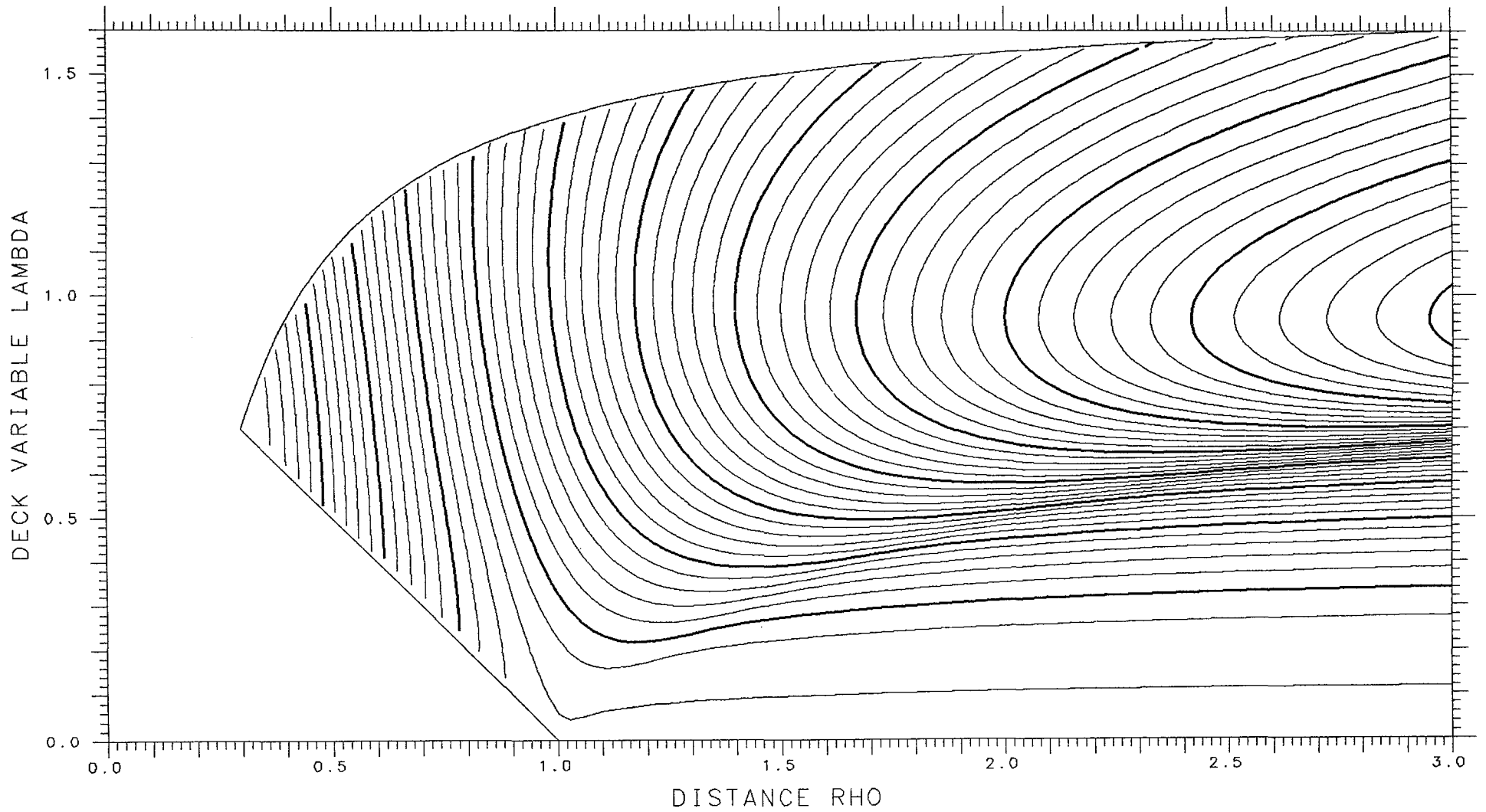

INERTIA PERPENDICULAR ASYMMETRY DELTA= .325

TANGENT 1.38174 SPACING .05

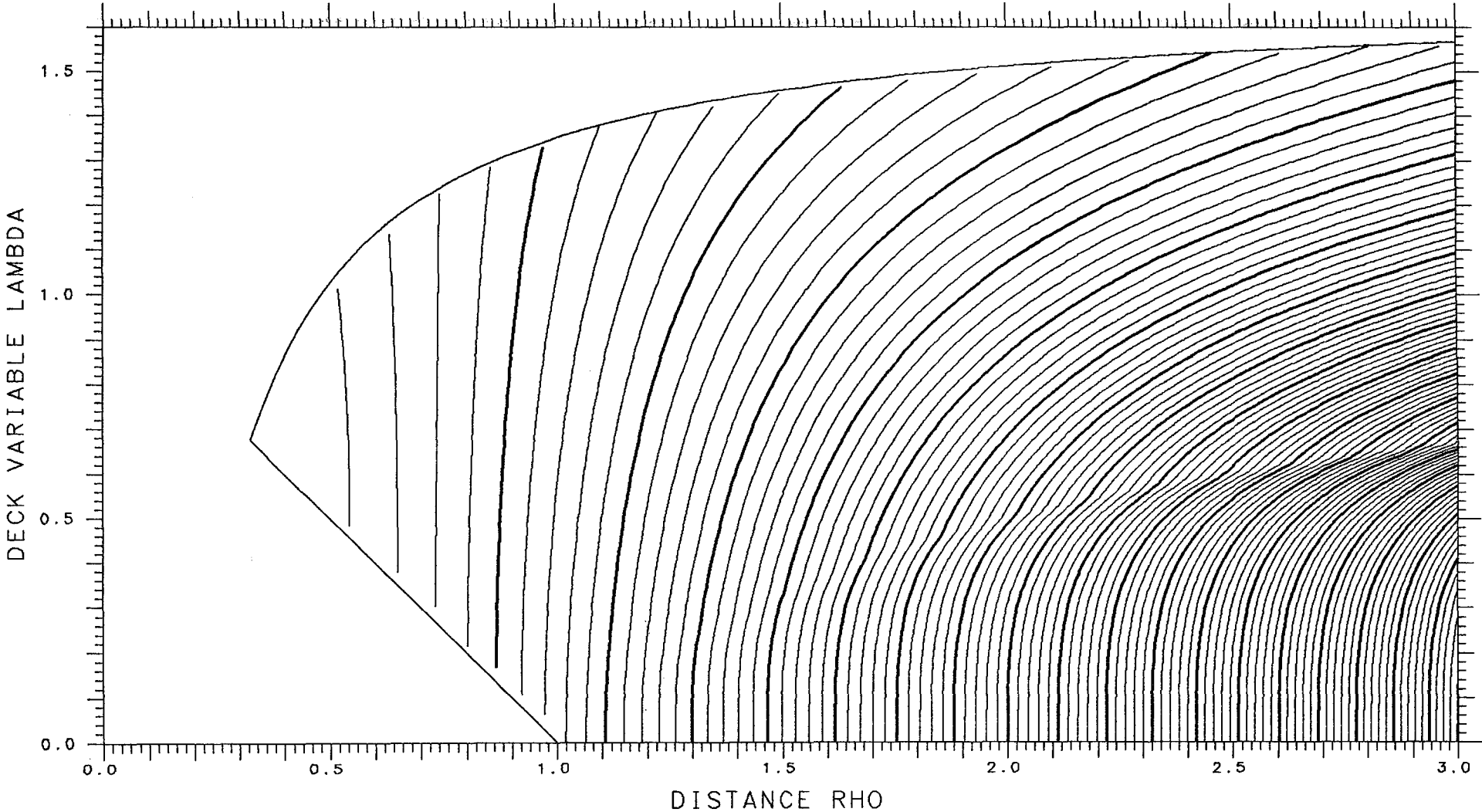

INERTIA PARALLEL ASYMMETRY DELTA= .275

TANGENT .79967 SPACING .01

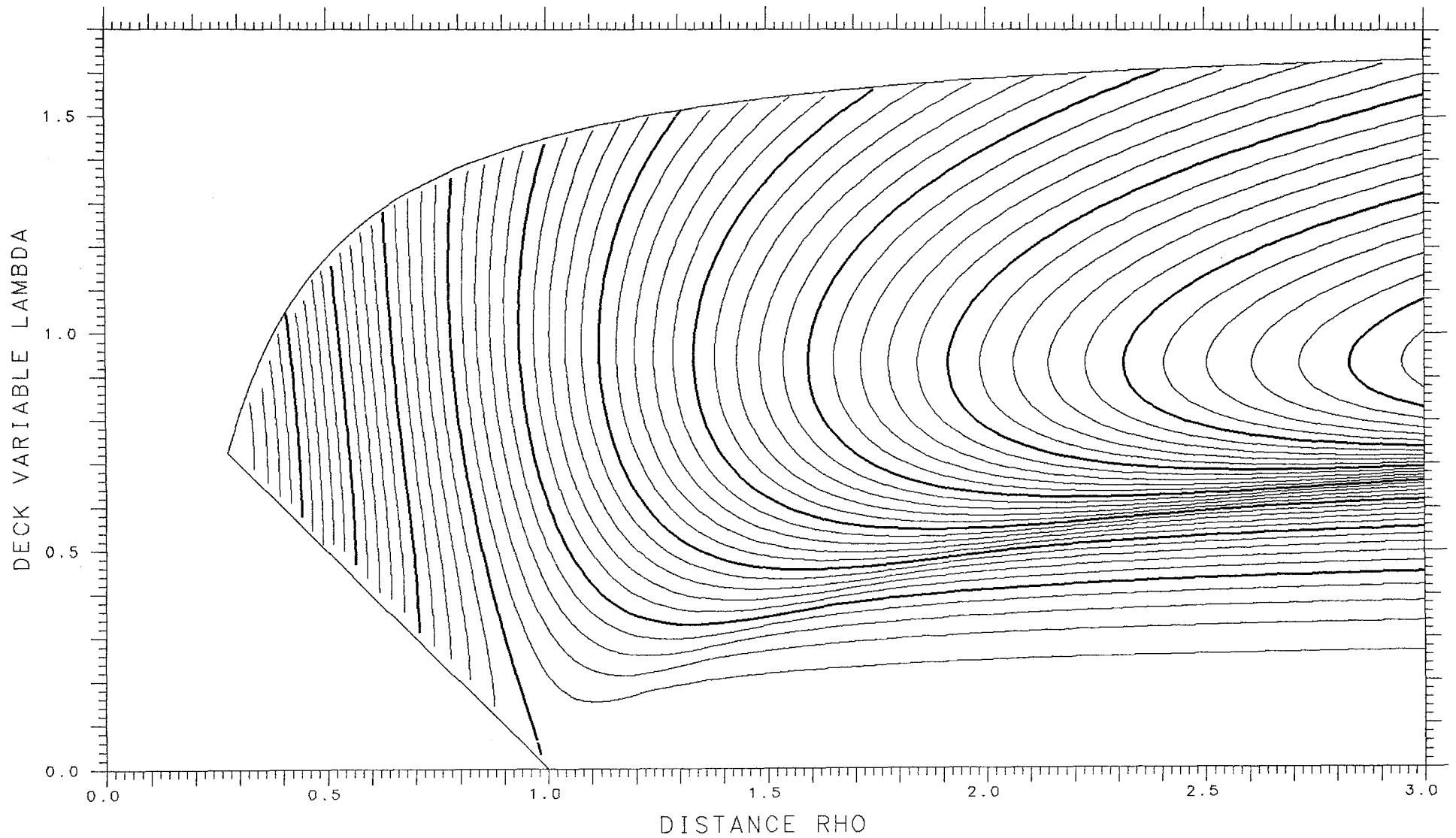

INERTIA PERPENDICULAR ASYMMETRY DELTA= .350

TANGENT 1.32188 SPACING .05

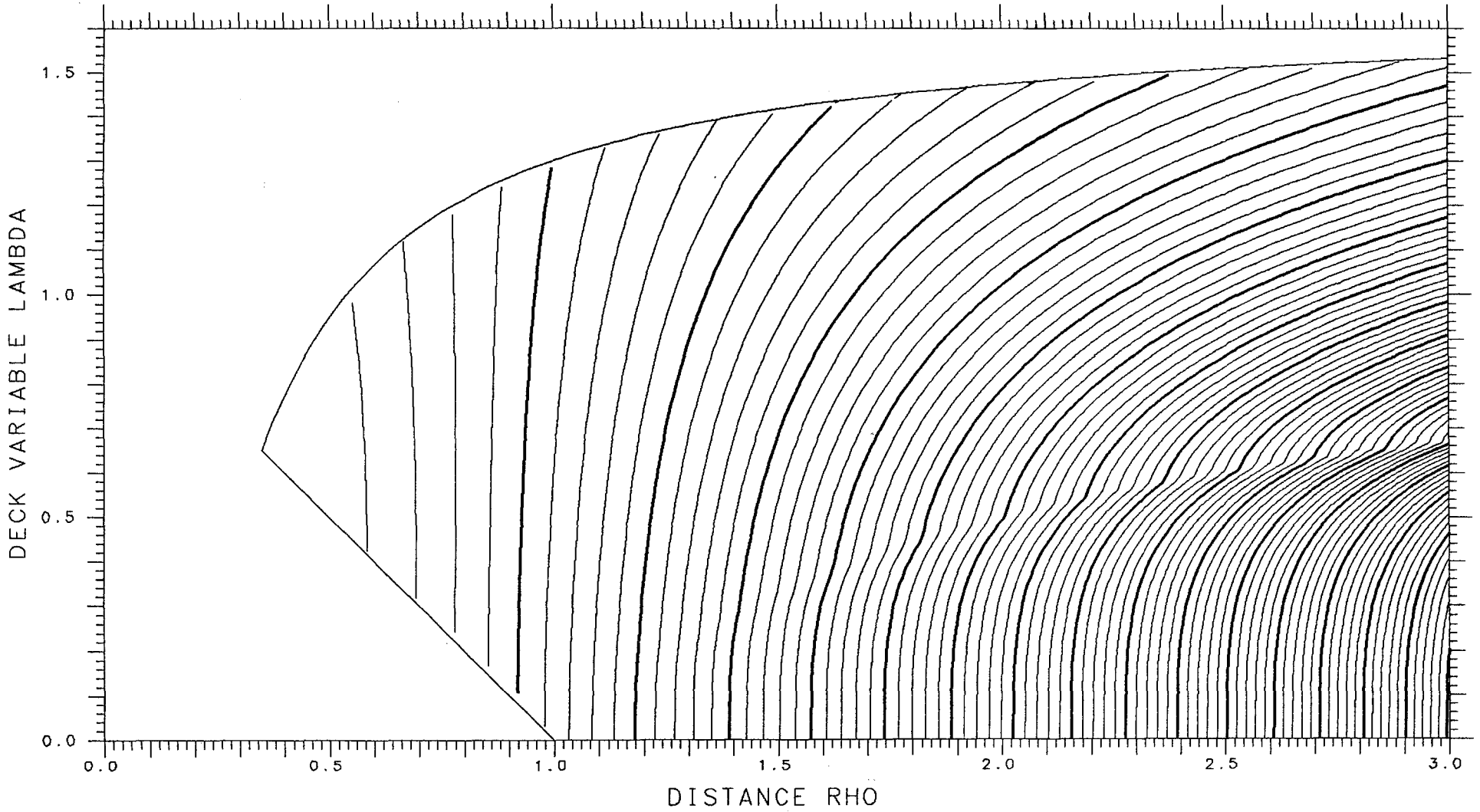

INERTIA PARALLEL ASYMMETRY DELTA= .250

TANGENT .77798 SPACING .01

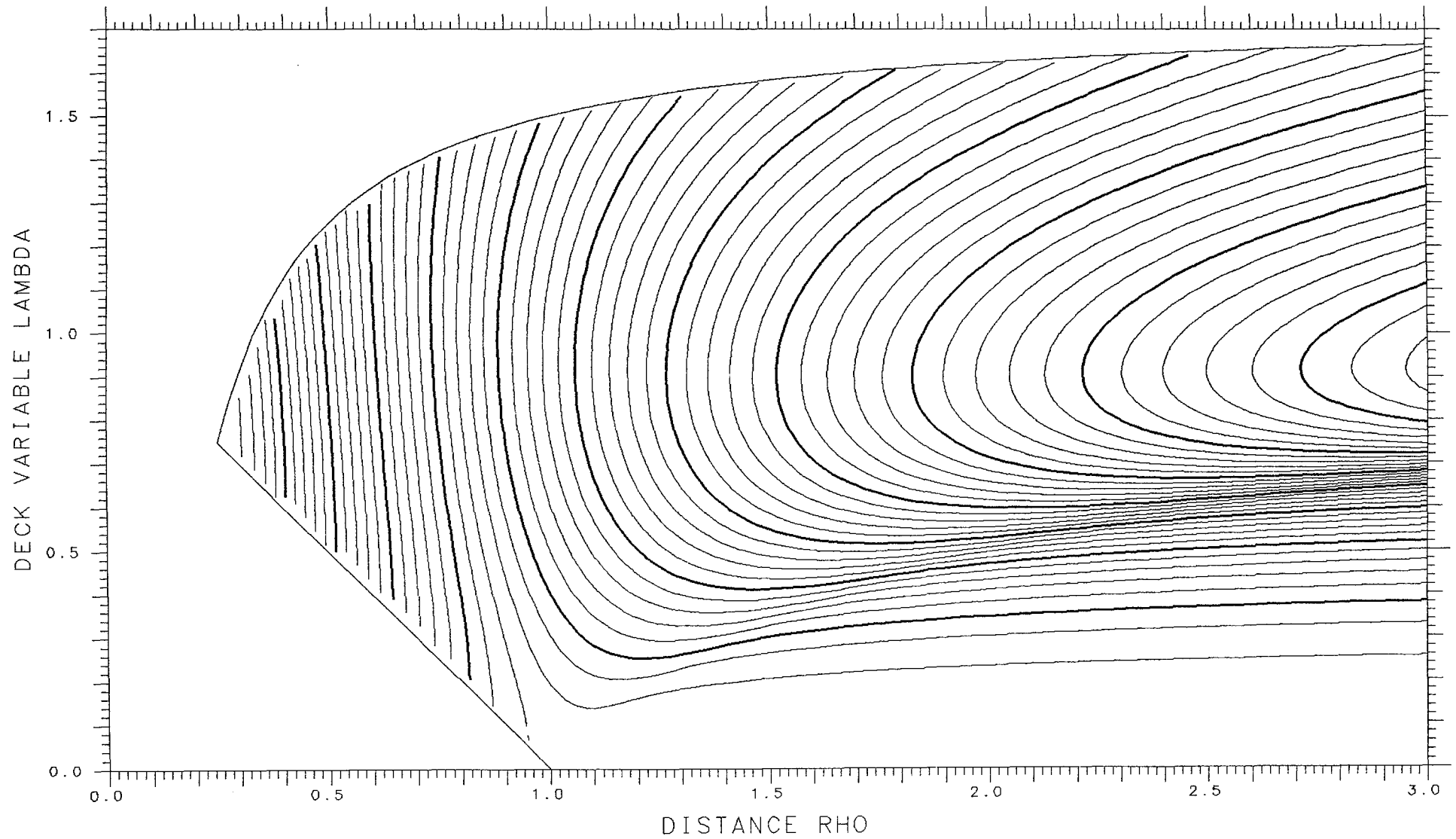

INERTIA PERPENDICULAR ASYMMETRY DELTA= .375

TANGENT 1.26875 SPACING .05

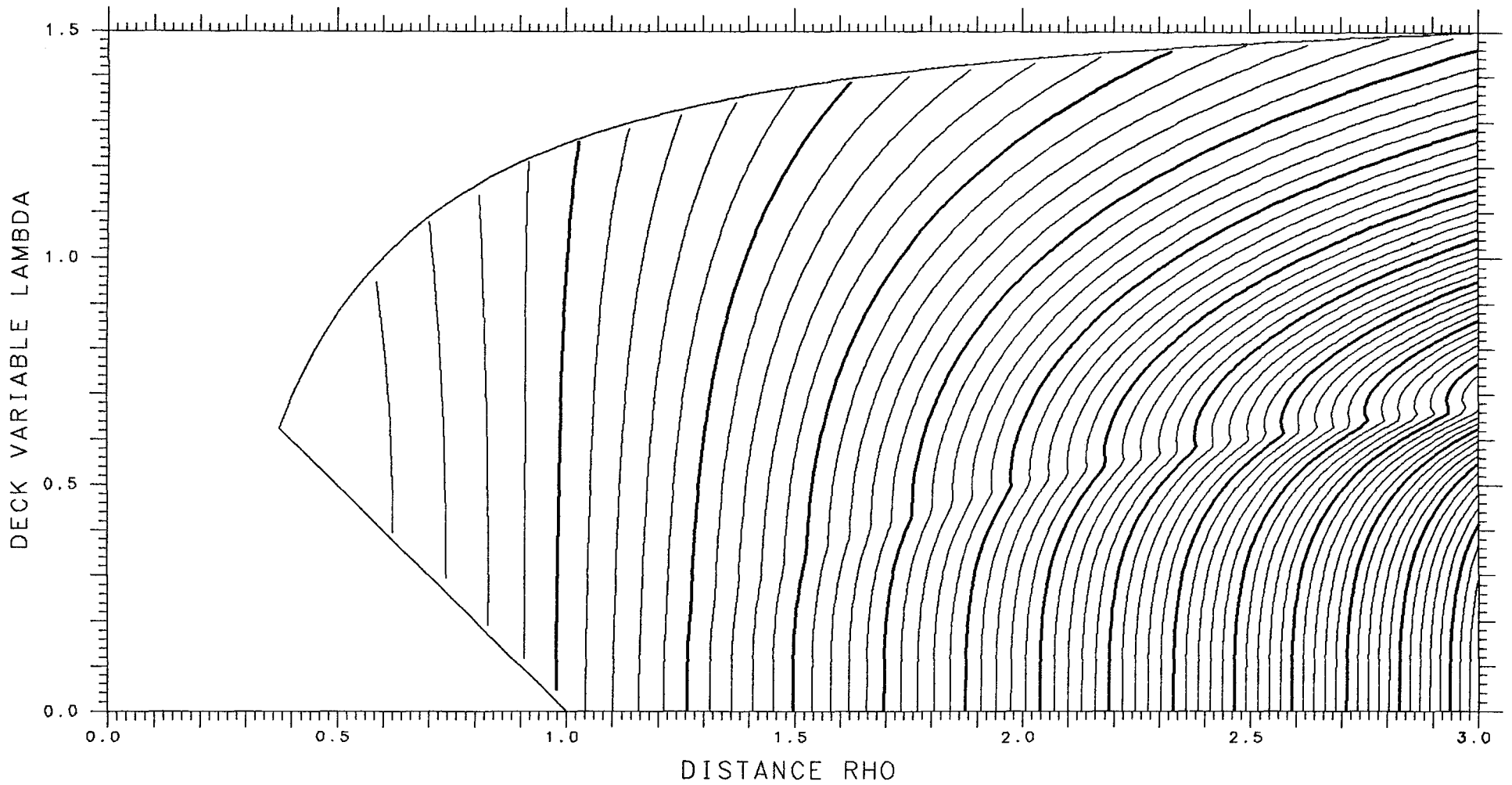

INERTIA PARALLEL ASYMMETRY DELTA= .225

TANGENT .75604 SPACING .01

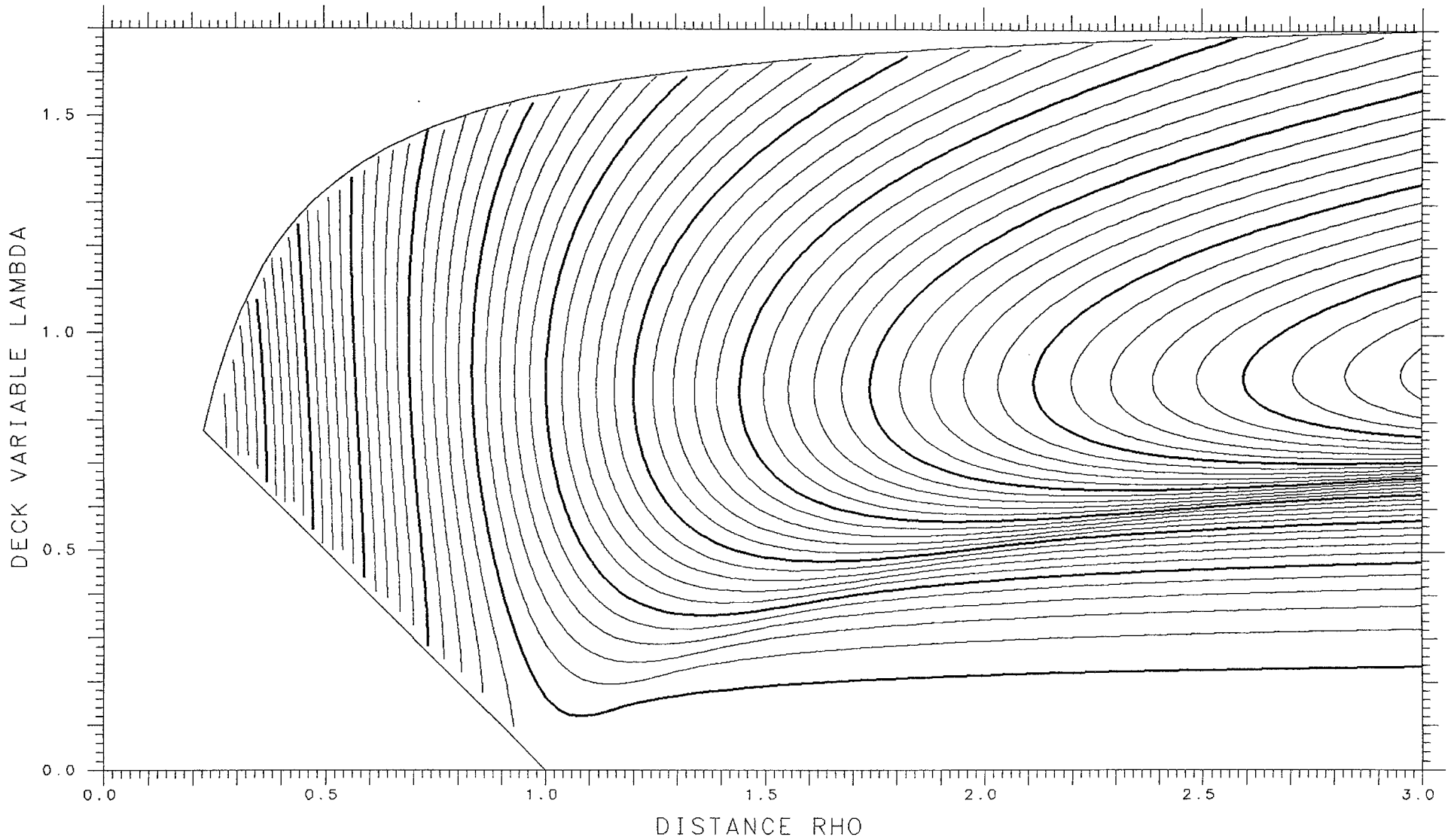

INERTIA PERPENDICULAR ASYMMETRY DELTA= .400

TANGENT 1.22224 SPACING .05

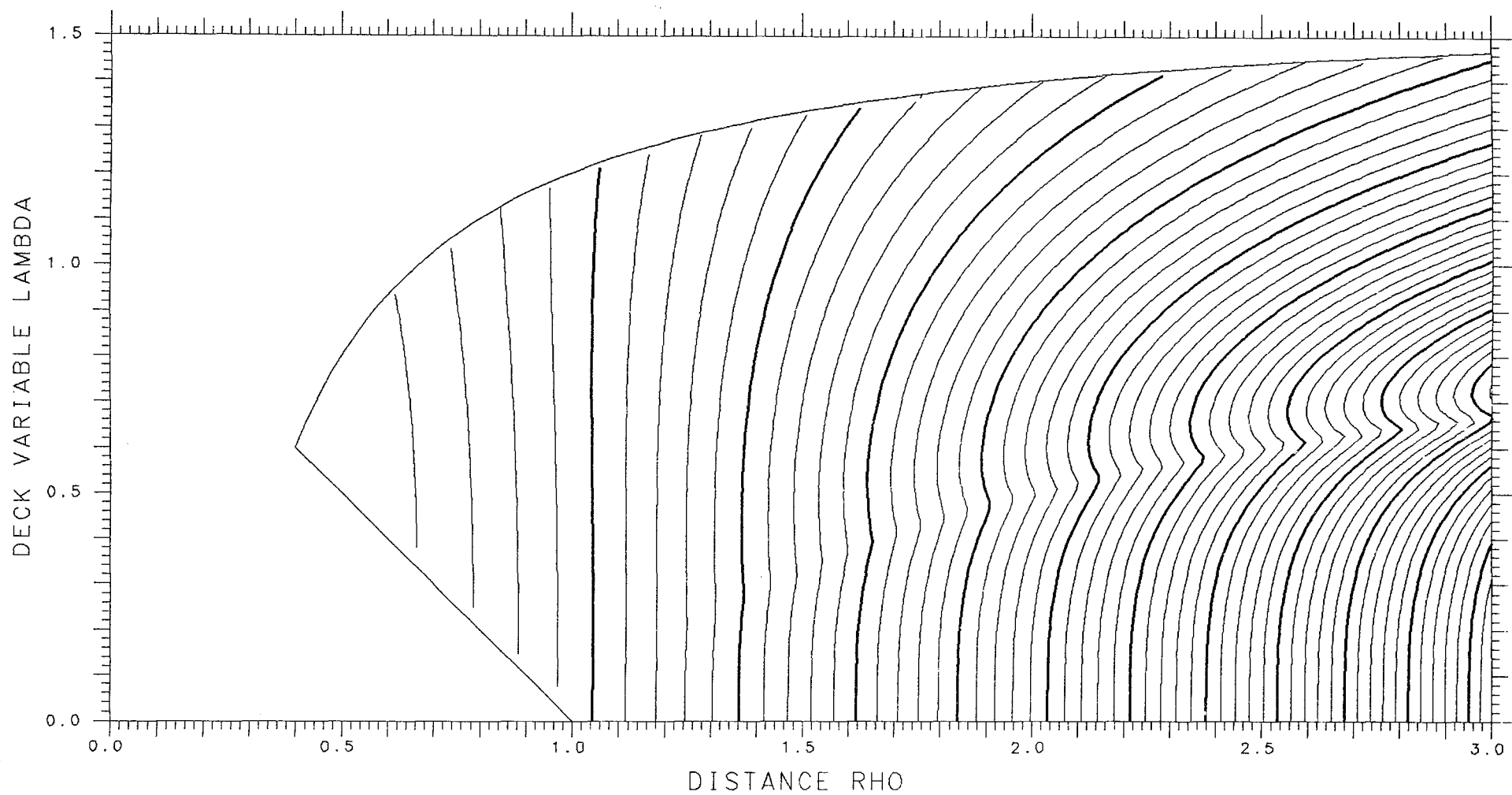

INERTIA PARALLEL ASYMMETRY DELTA= .200

TANGENT .73432 SPACING .01

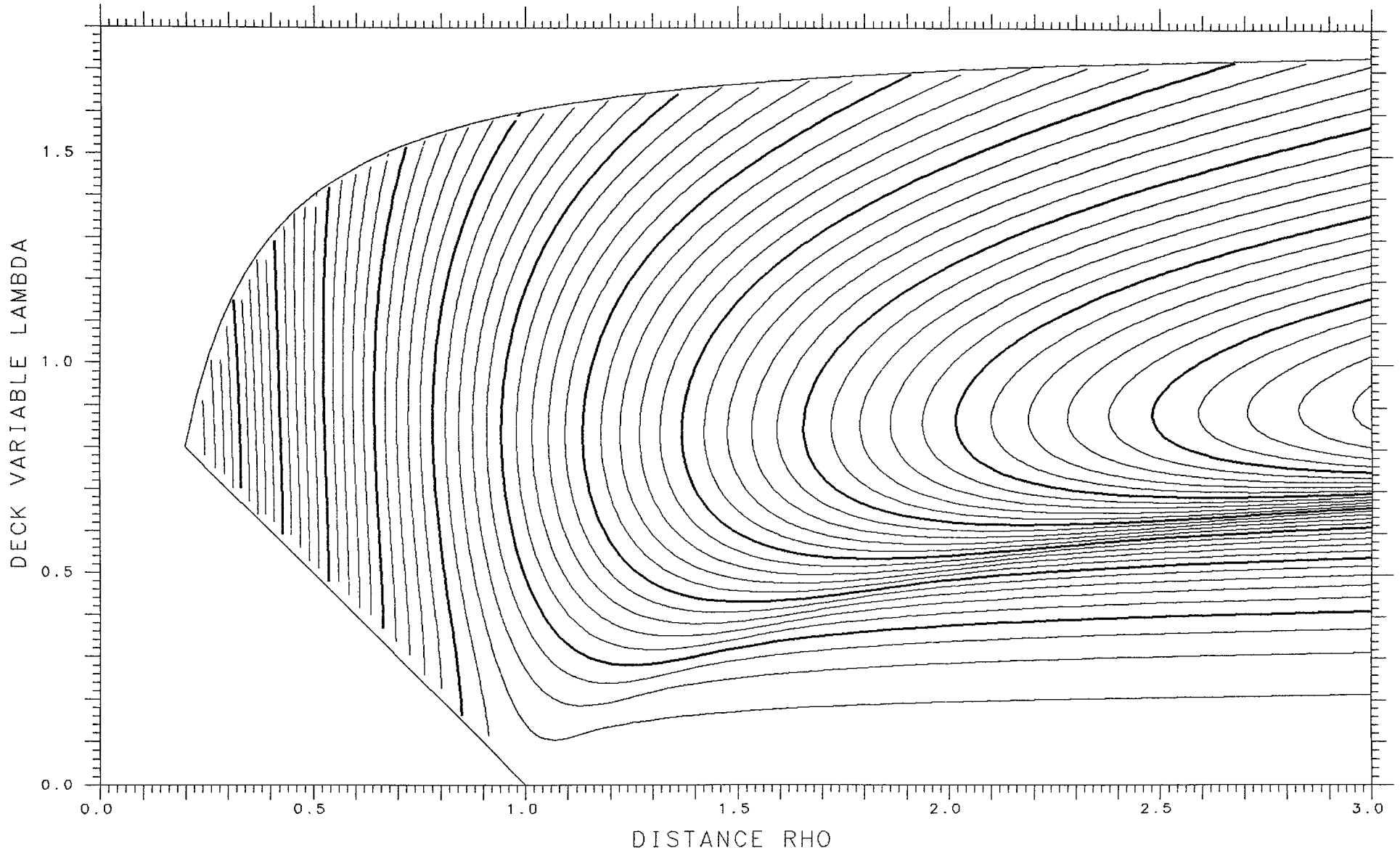

INERTIA PERPENDICULAR ASYMMETRY DELTA= .425

TANGENT 1.18205 SPACING .05

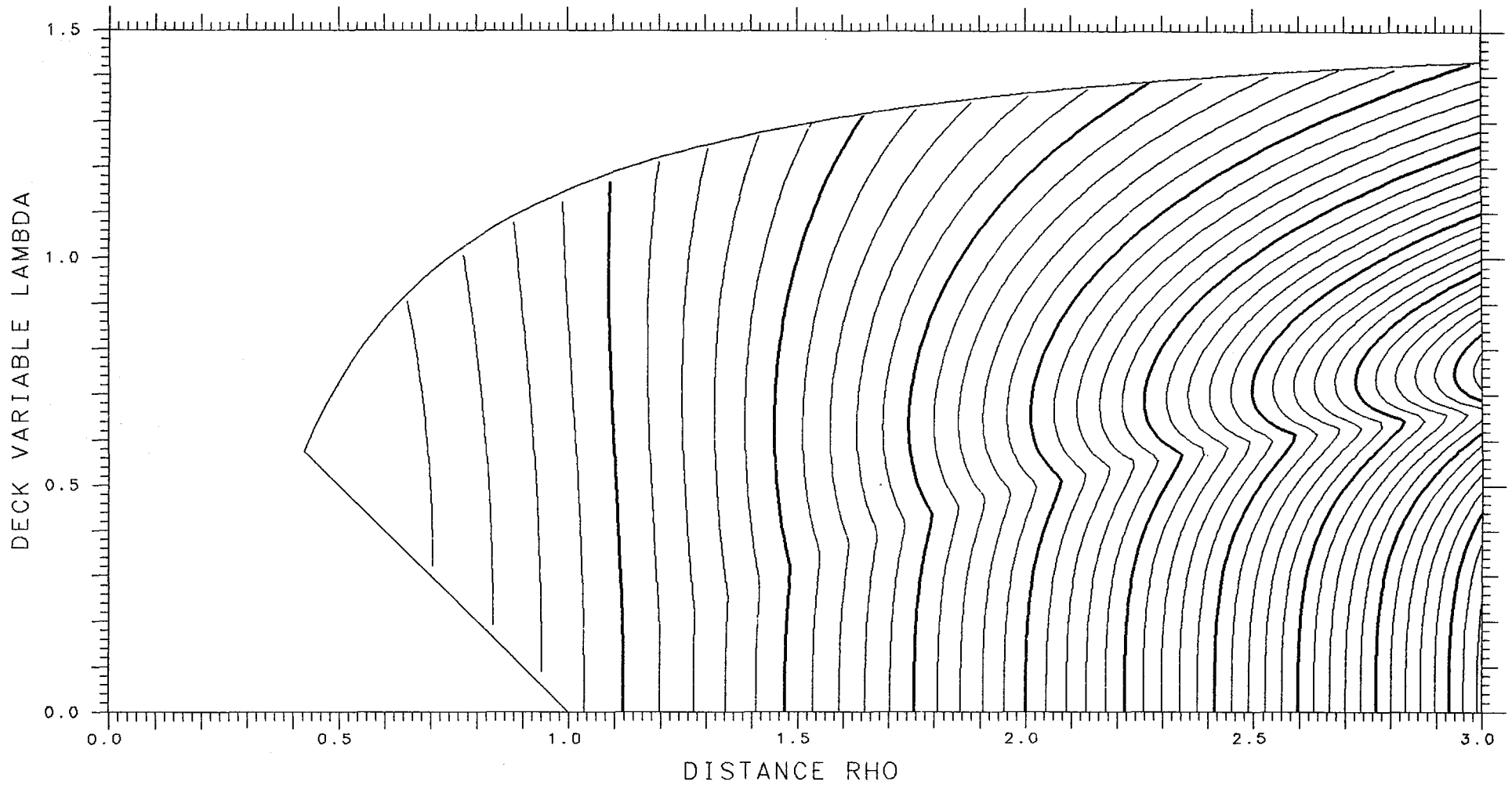

INERTIA PARALLEL ASYMMETRY DELTA= .175

TANGENT .71330 SPACING .01

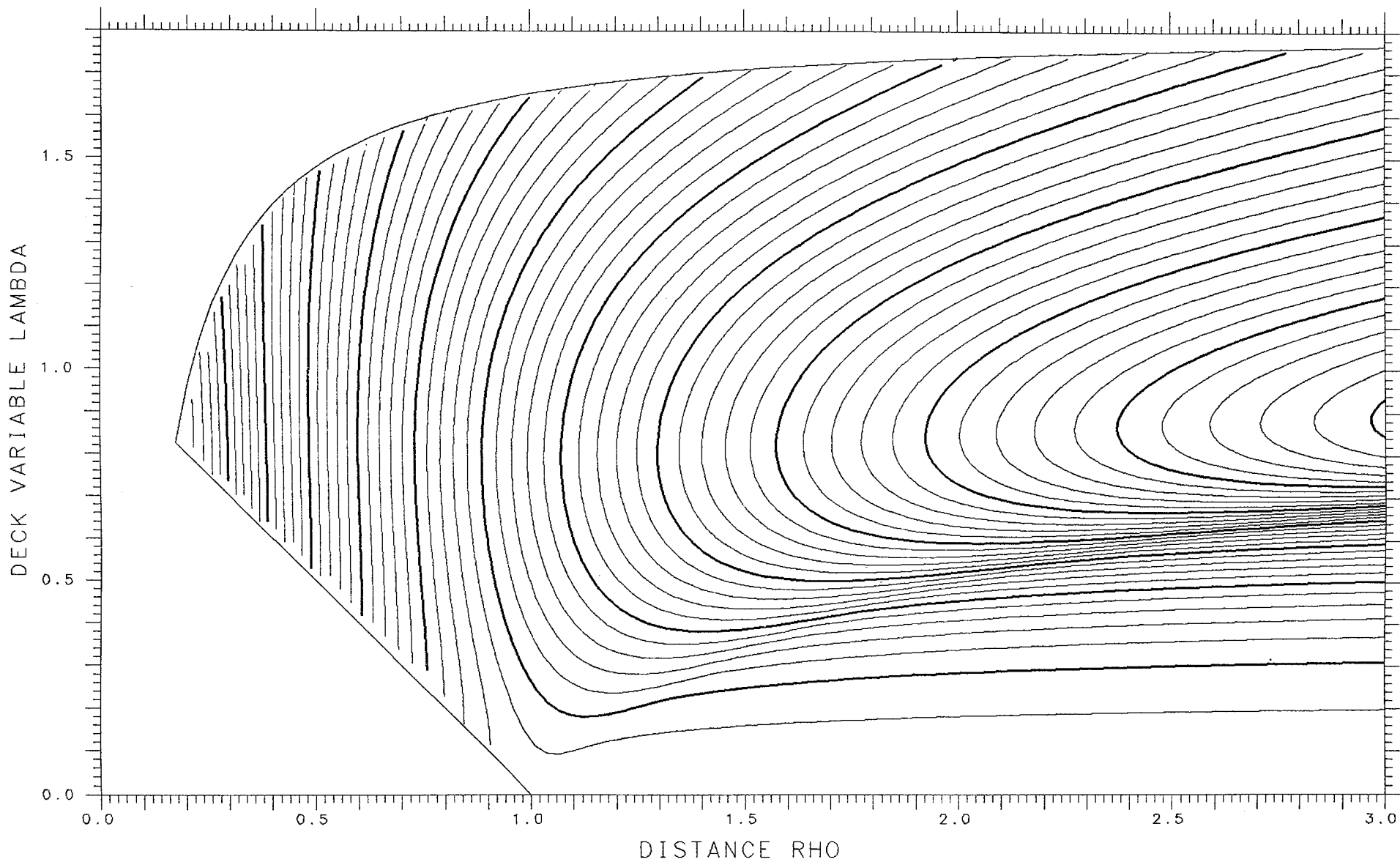

INERTIA PERPENDICULAR ASYMMETRY DELTA= .450

TANGENT 1.14771 SPACING .05

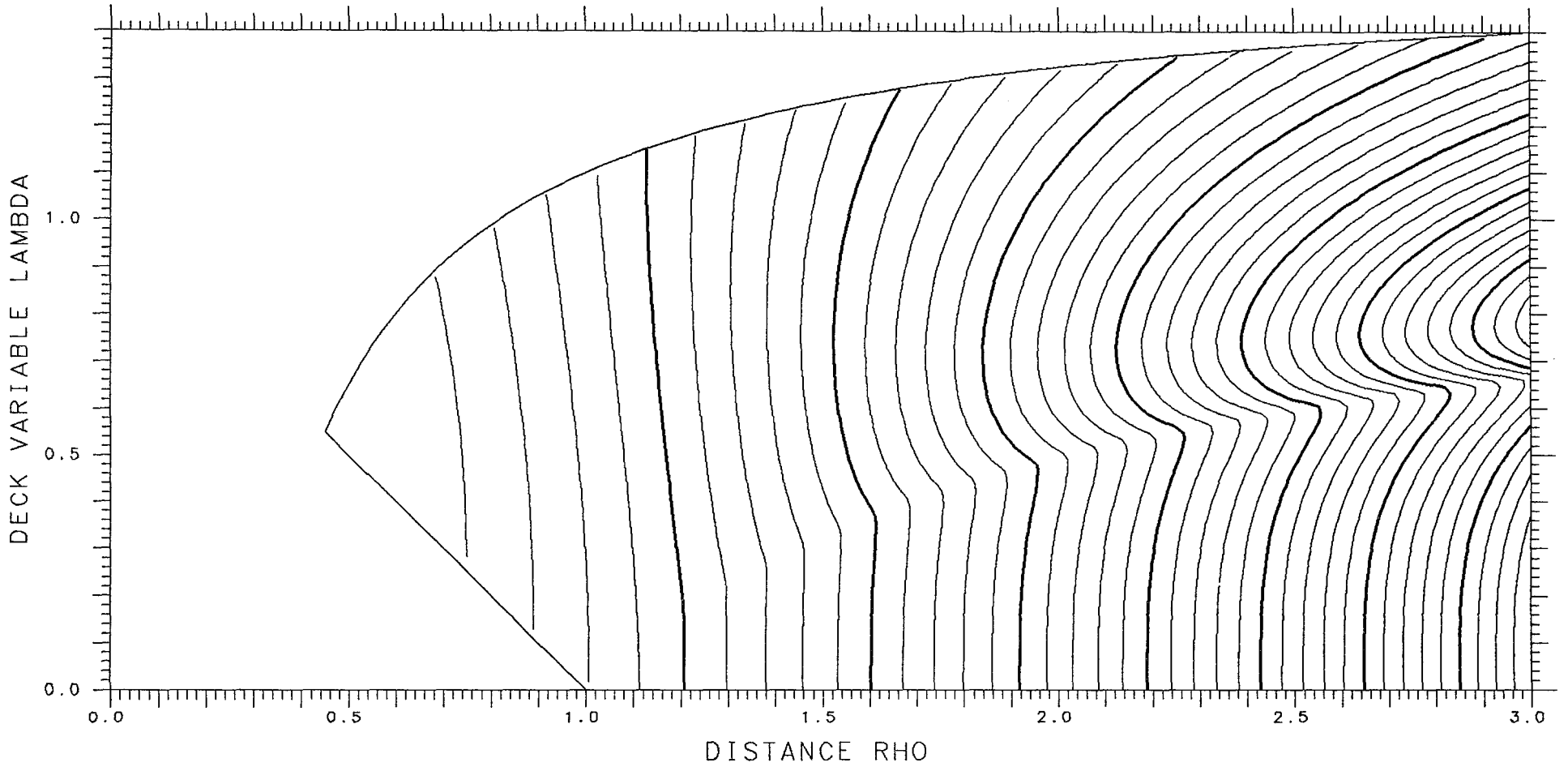

INERTIA PARALLEL ASYMMETRY DELTA= .150

TANGENT .69353 SPACING .01

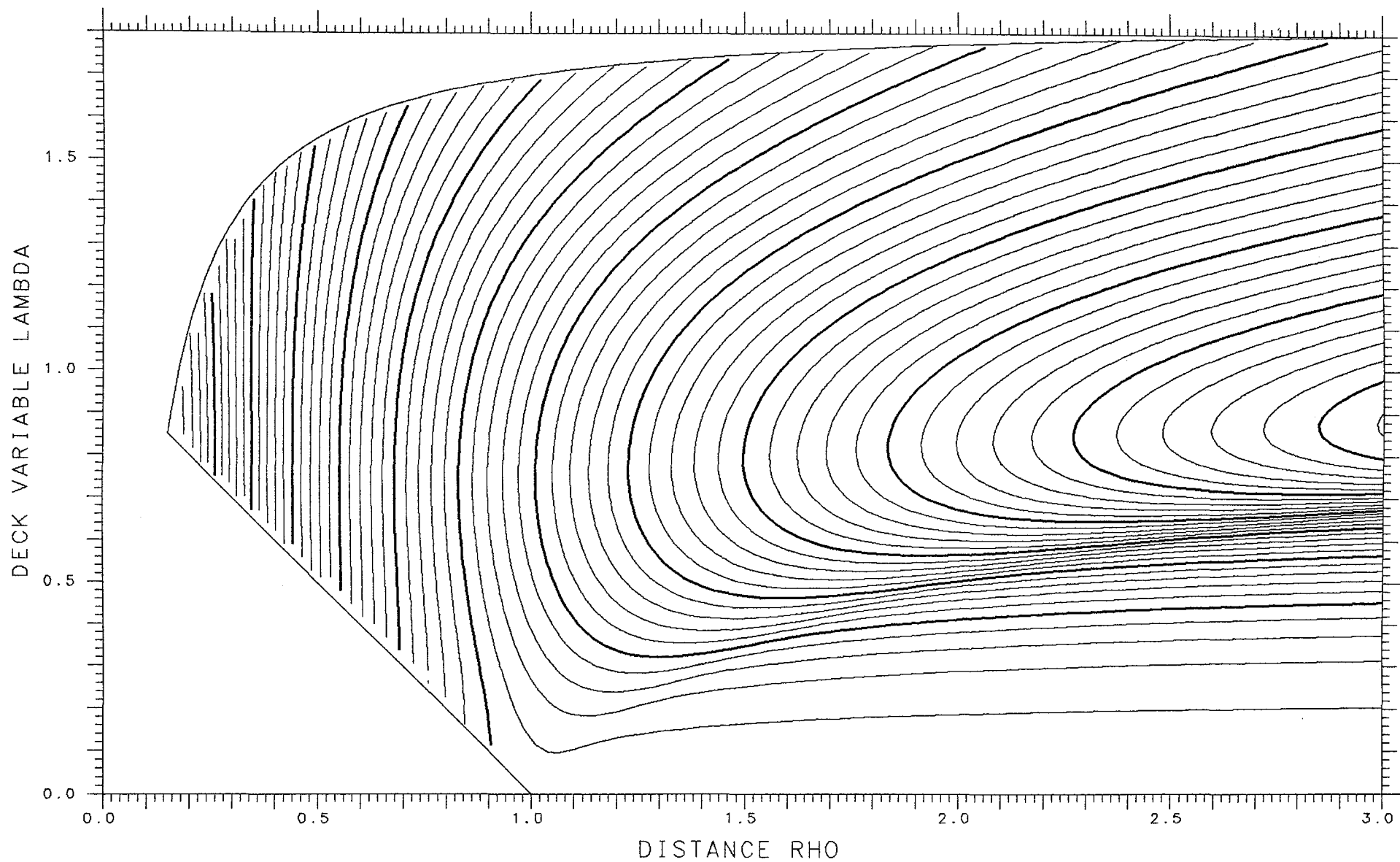

INERTIA PERPENDICULAR ASYMMETRY DELTA= .475

TANGENT 1.11870 SPACING .05

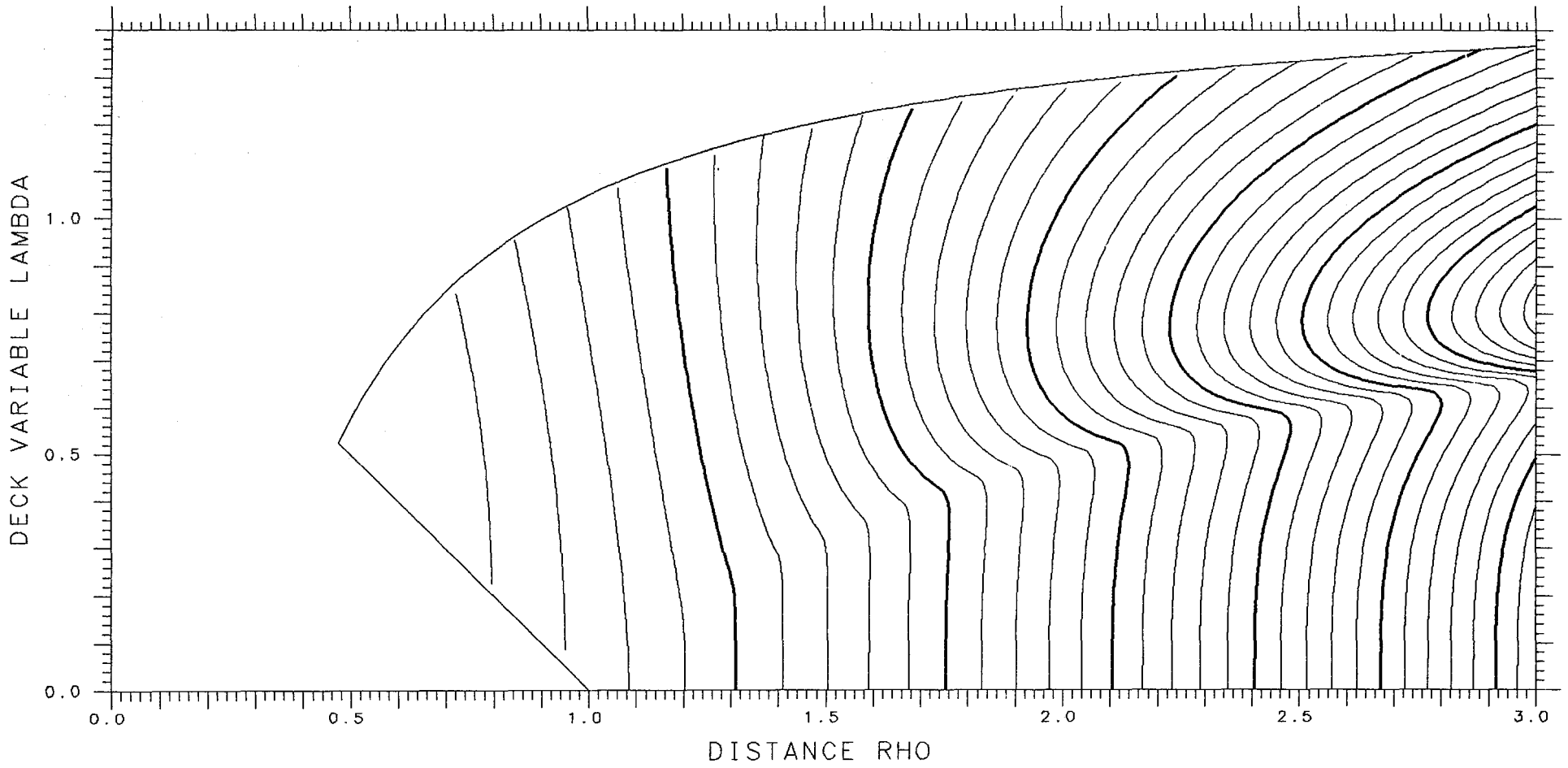

INERTIA PARALLEL ASYMMETRY DELTA= .125

TANGENT .67556 SPACING .01

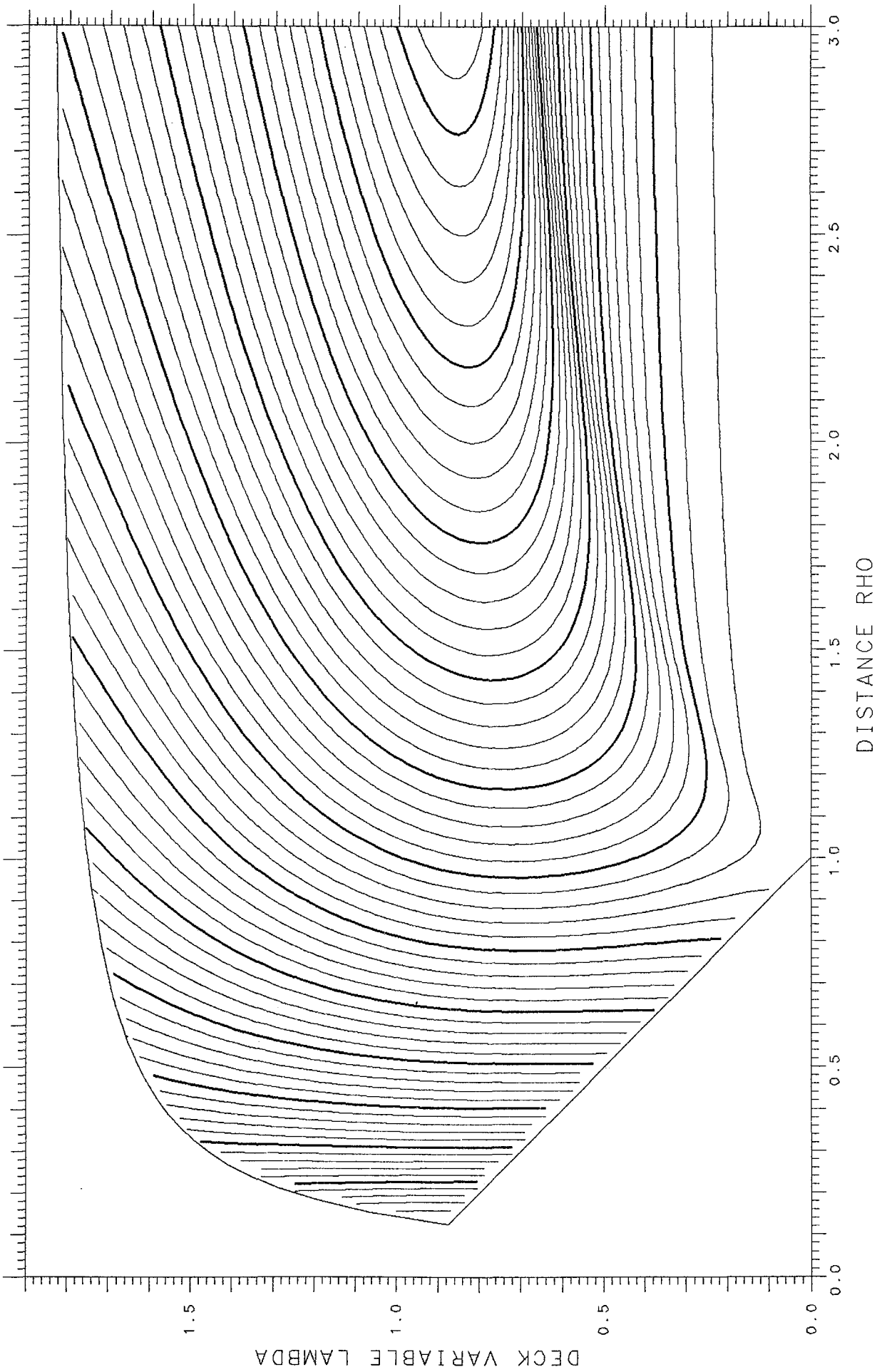

INERTIA PERPENDICULAR ASYMMETRY DELTA= .500

TANGENT 1.09446 SPACING .05

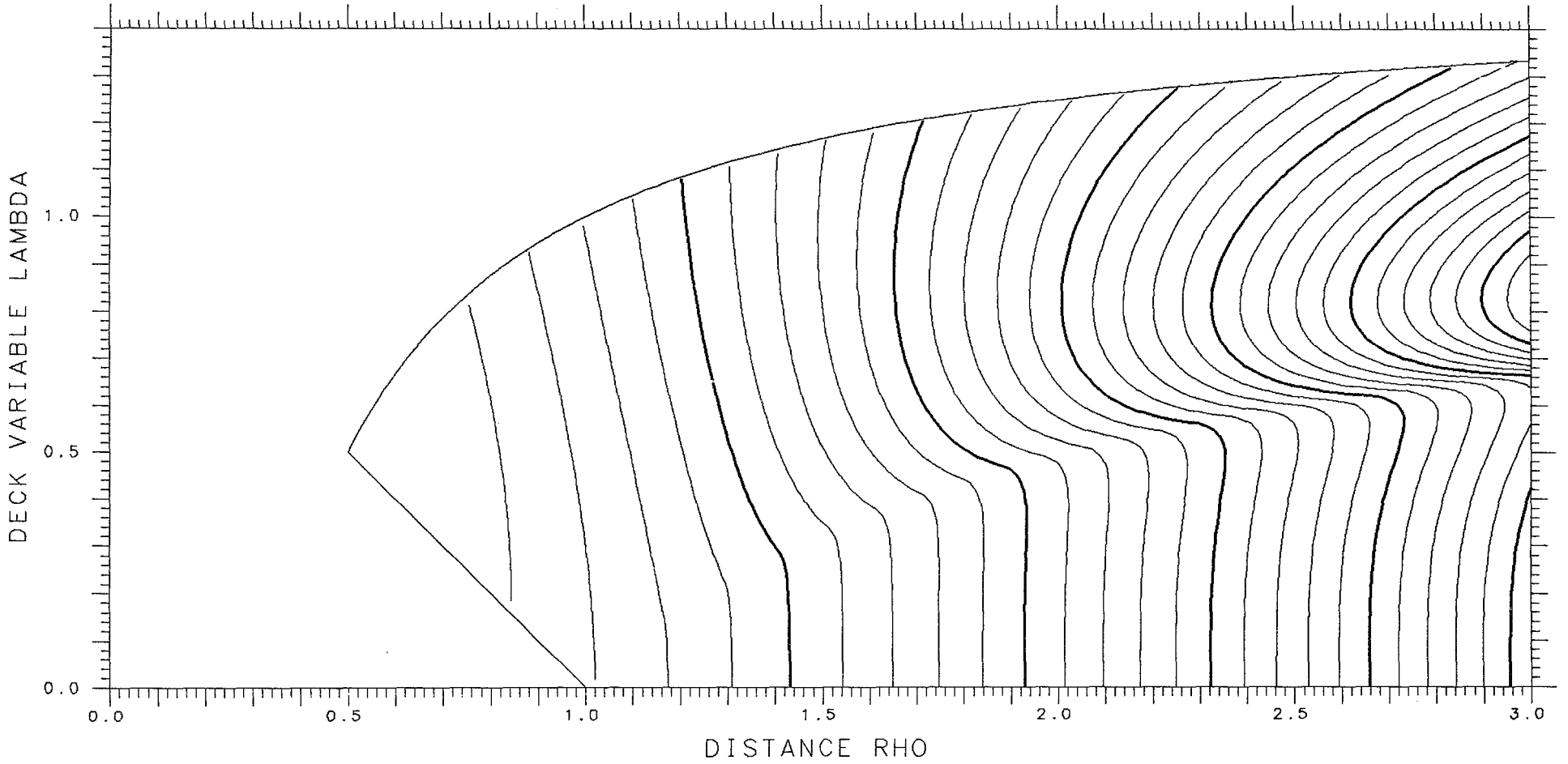

INERTIA PARALLEL ASYMMETRY DELTA= .100

TANGENT .65995 SPACING .01

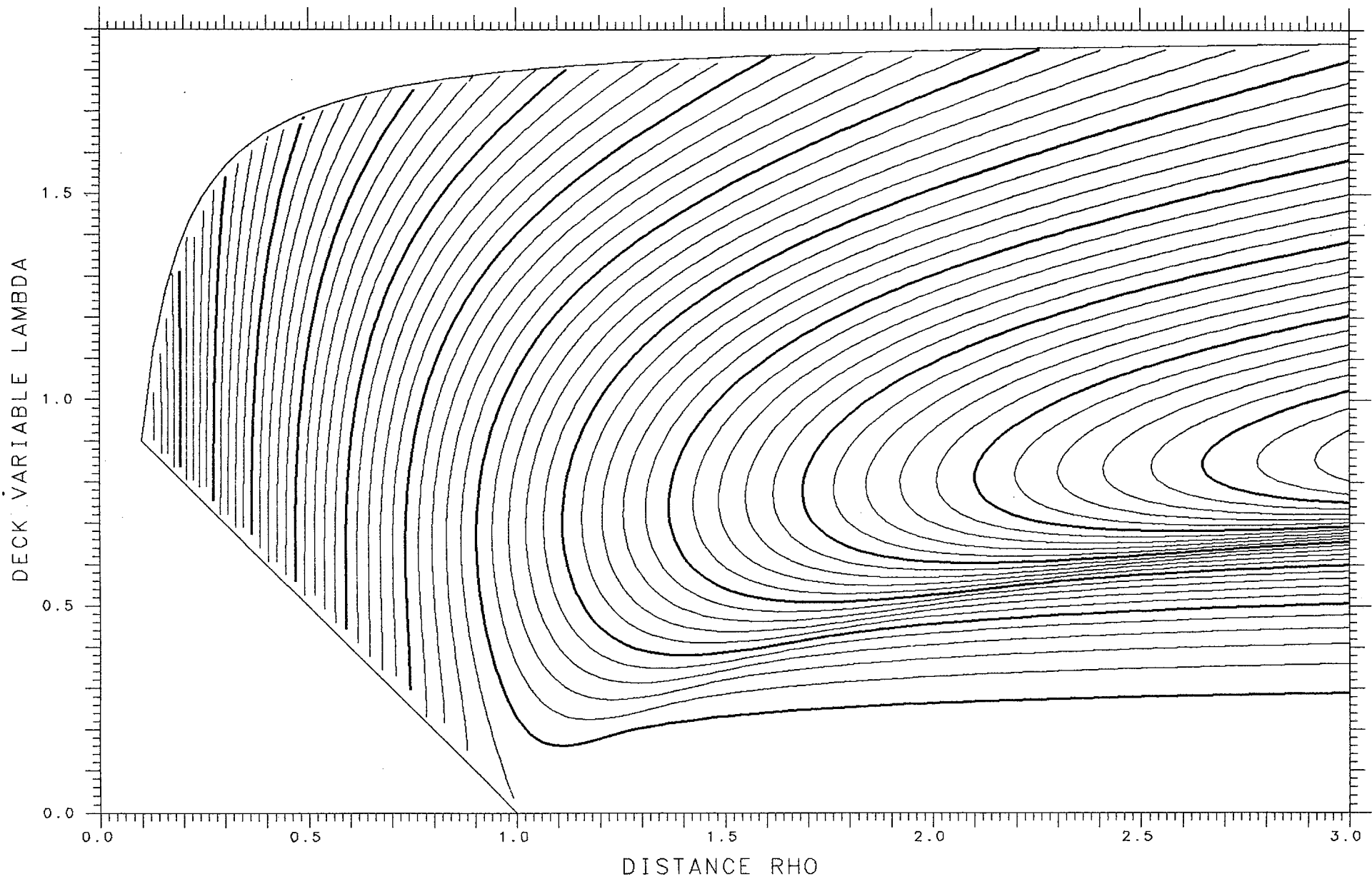

INERTIA PERPENDICULAR ASYMMETRY DELTA= .525

TANGENT 1.07440 SPACING .05

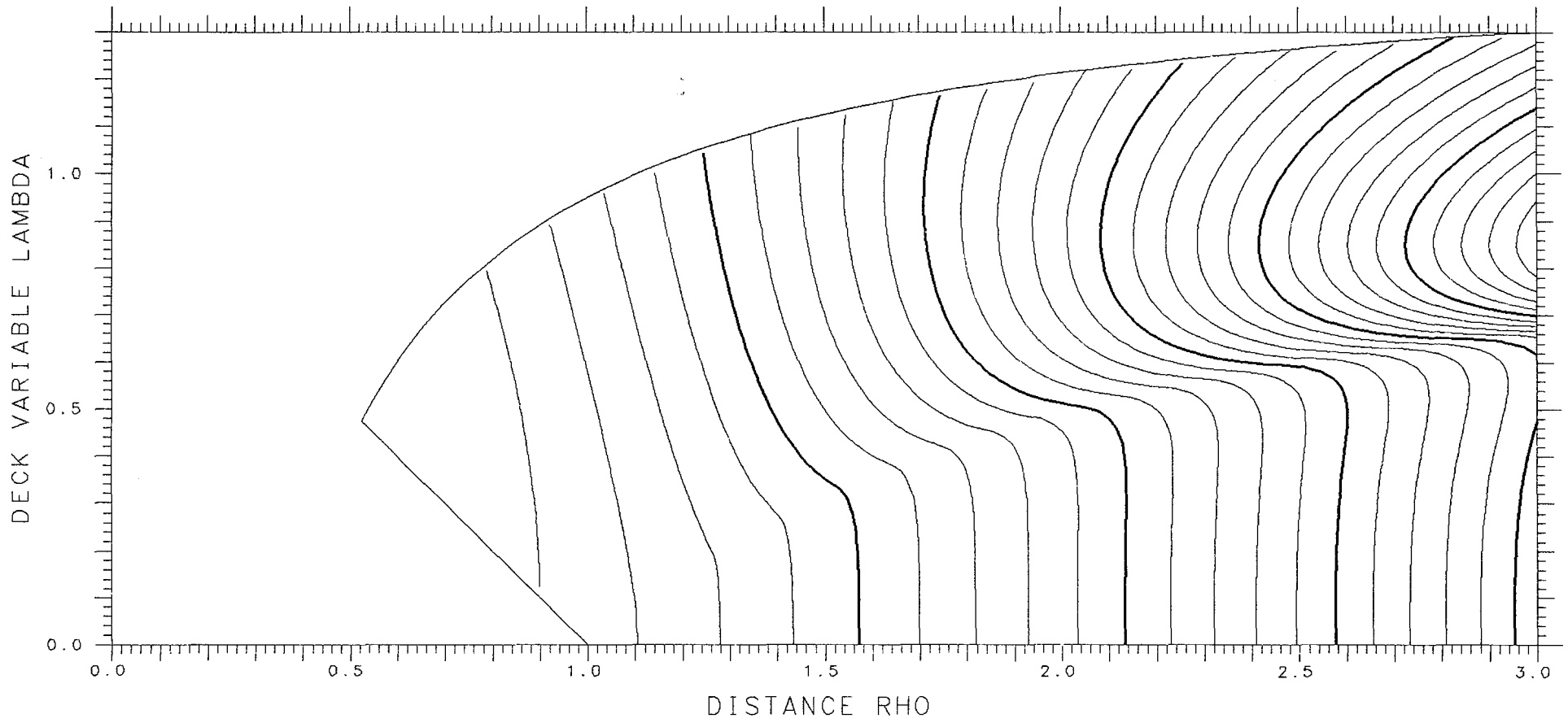

INERTIA PARALLEL ASYMMETRY DELTA= .075

TANGENT .64719 SPACING .01

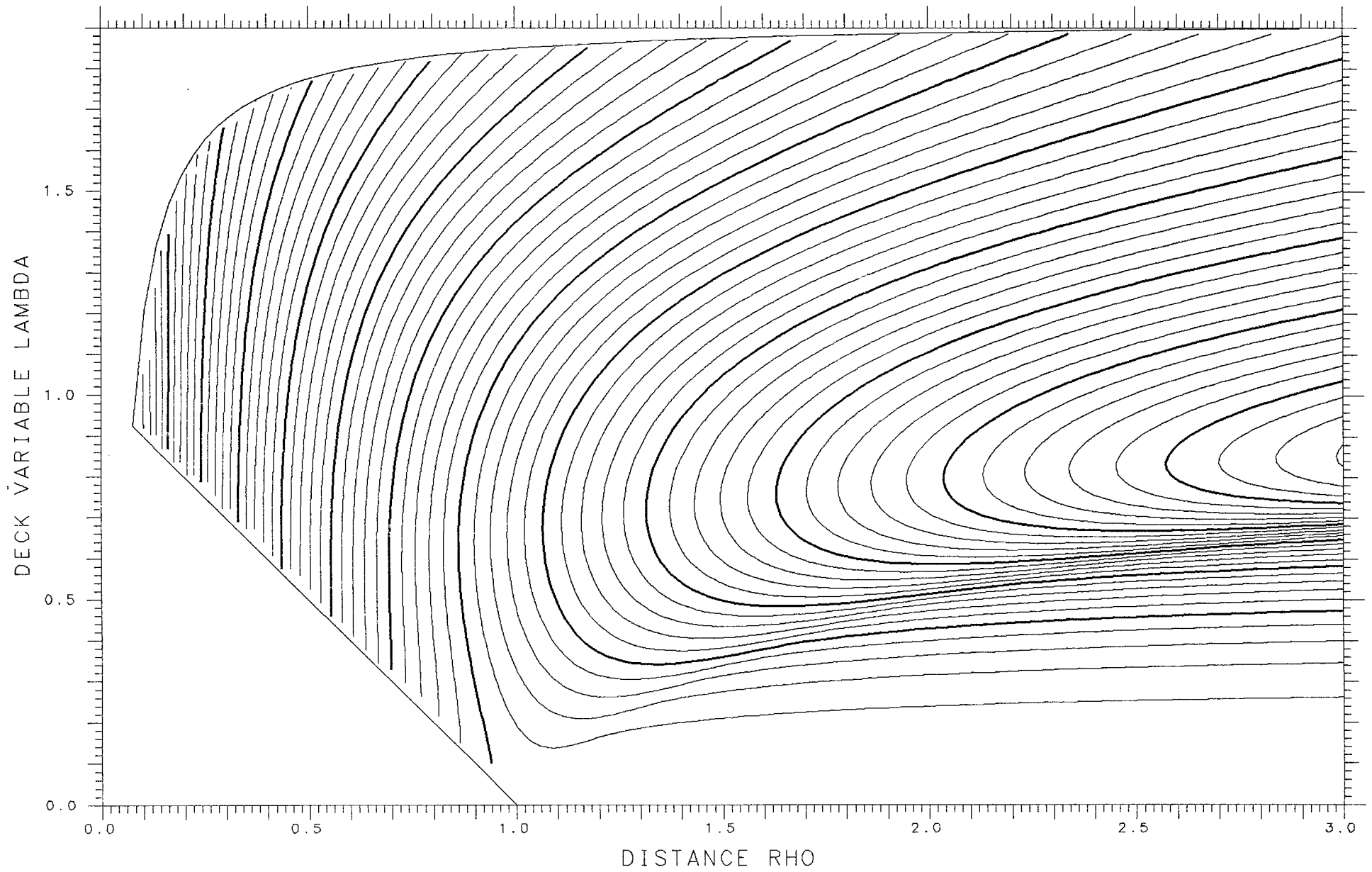

INERTIA PERPENDICULAR ASYMMETRY DELTA= .550

TANGENT 1.05798 SPACING .05

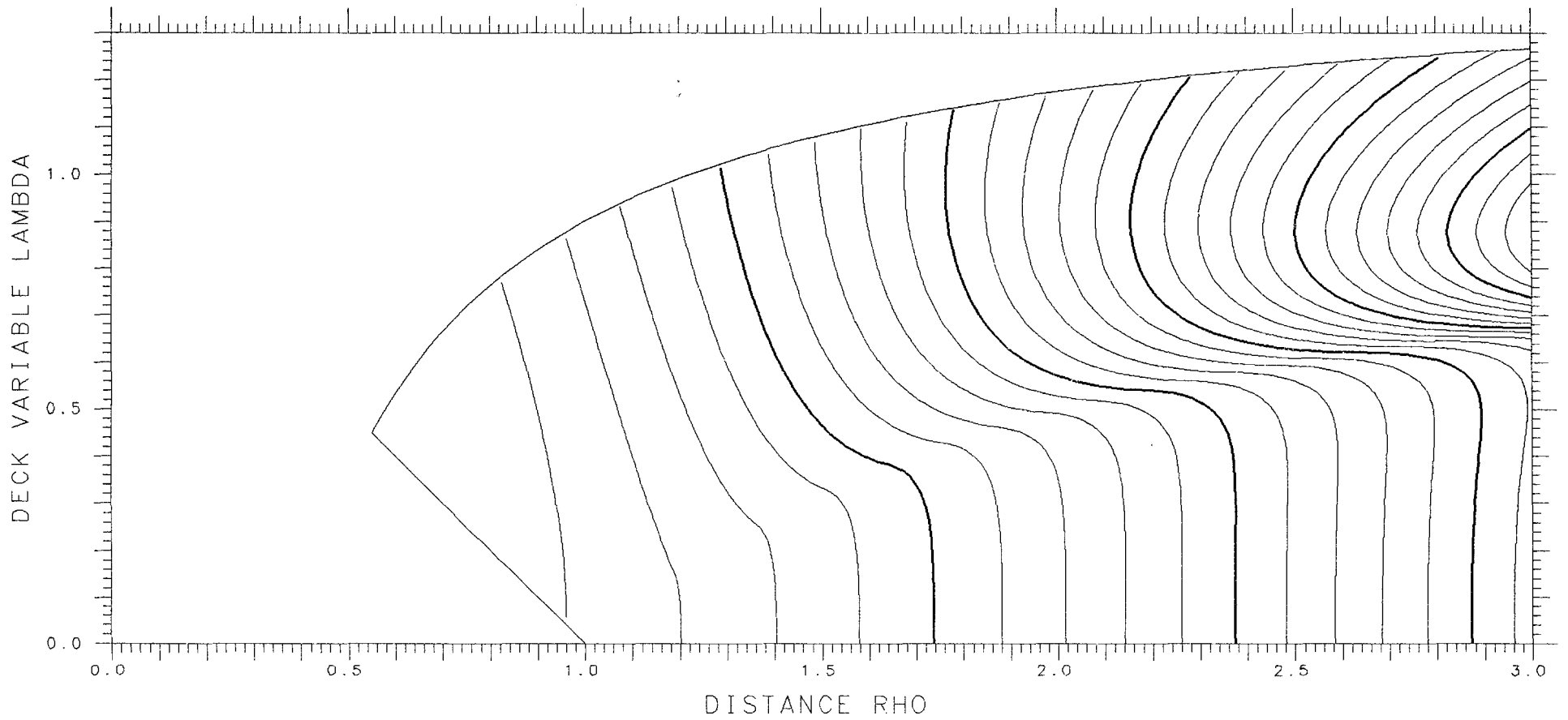

INERTIA PARALLEL ASYMMETRY DELTA= .050

TANGENT .63774 SPACING .01

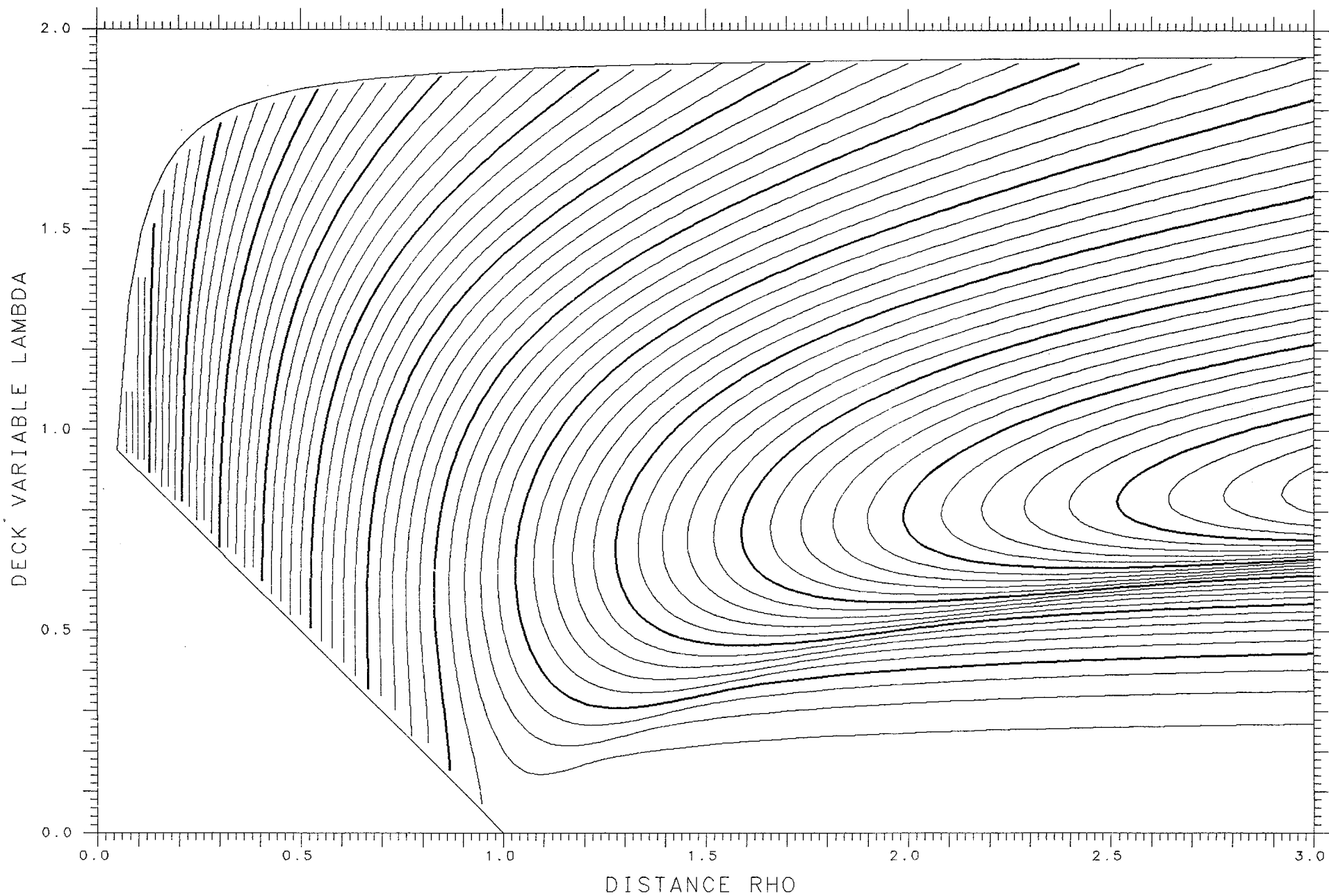

INERTIA PERPENDICULAR ASYMMETRY DELTA= .575

TANGENT 1.04468 SPACING .05

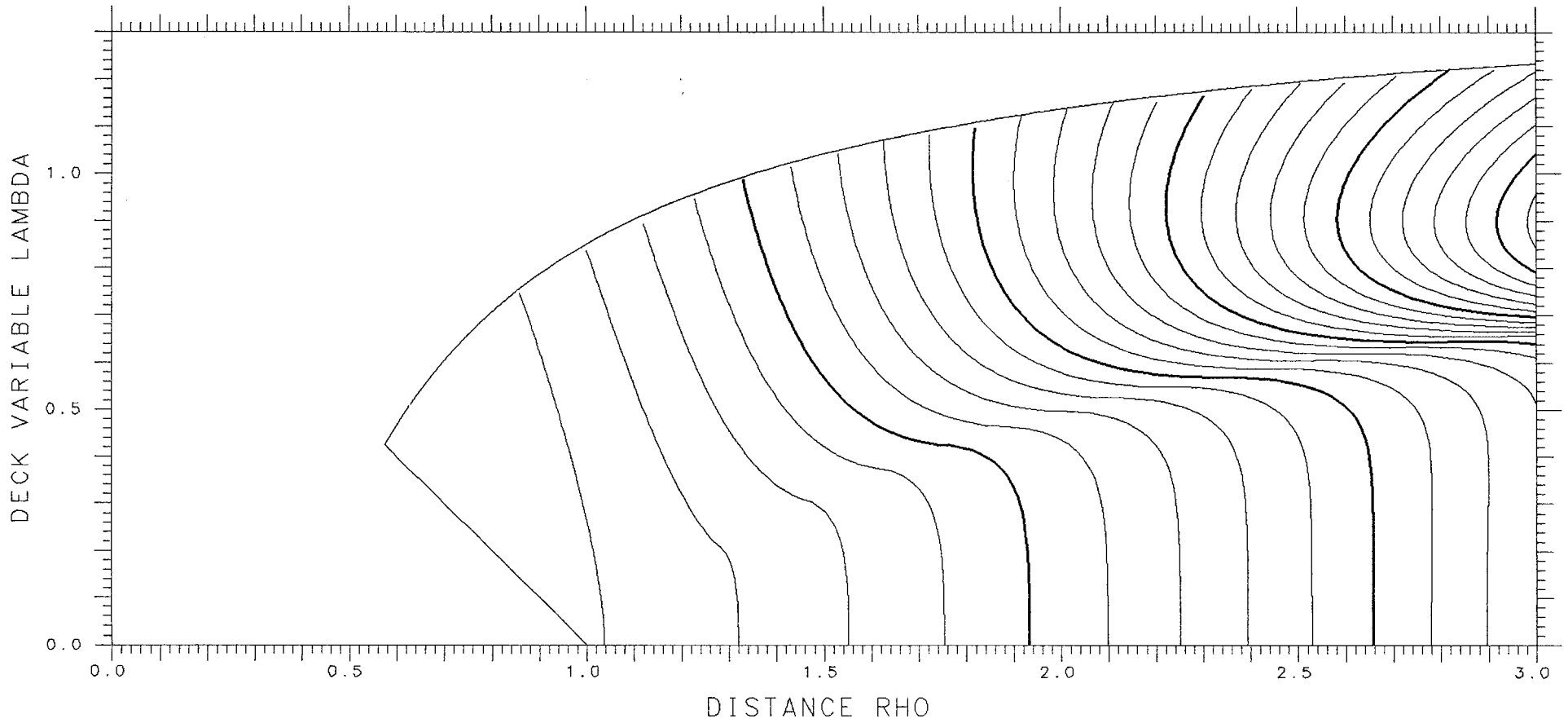

INERTIA PARALLEL ASYMMETRY DELTA= .025

TANGENT .63192 SPACING .01

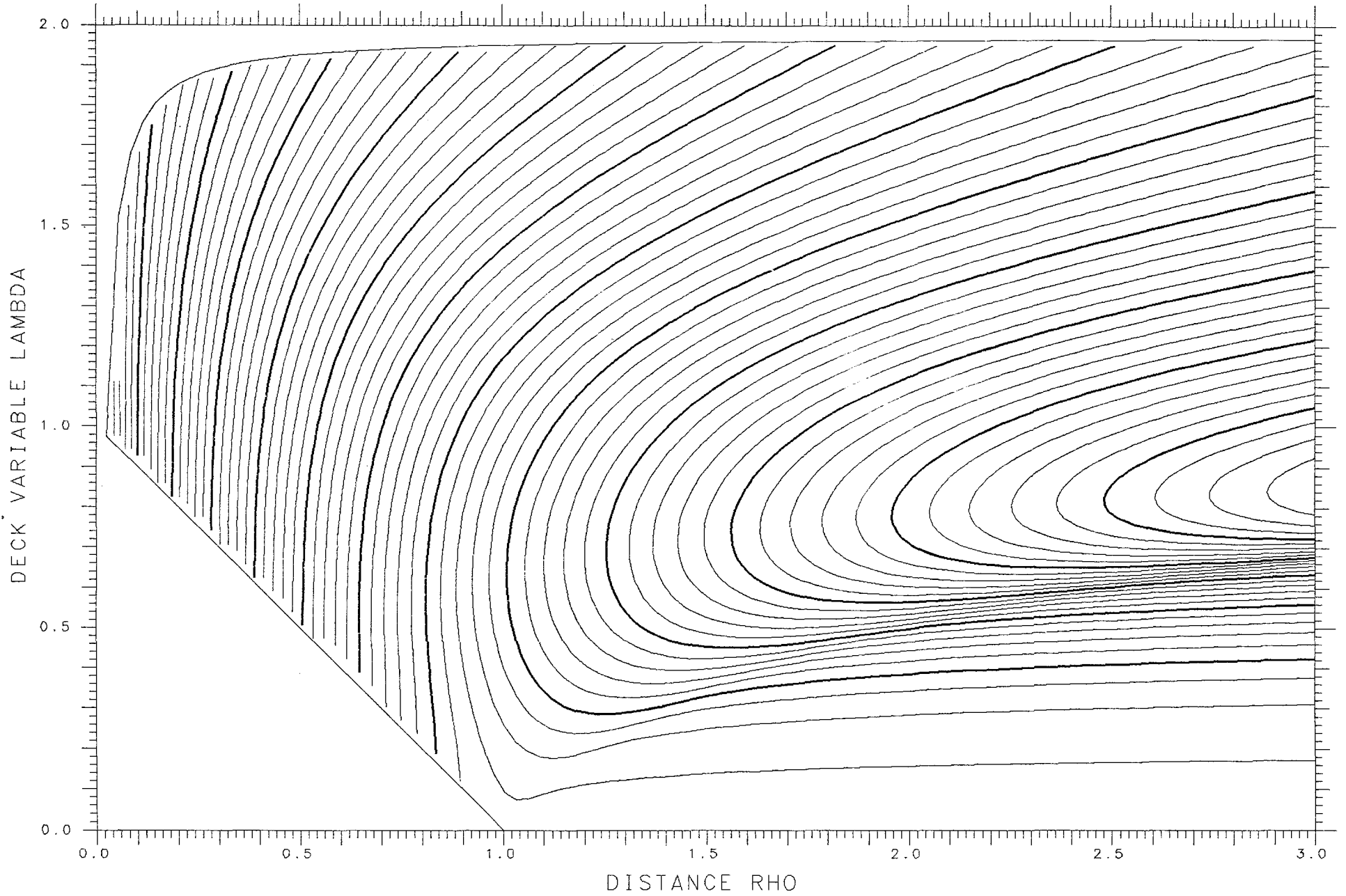

INERTIA PERPENDICULAR ASYMMETRY DELTA= .600

TANGENT 1.03401 SPACING .05

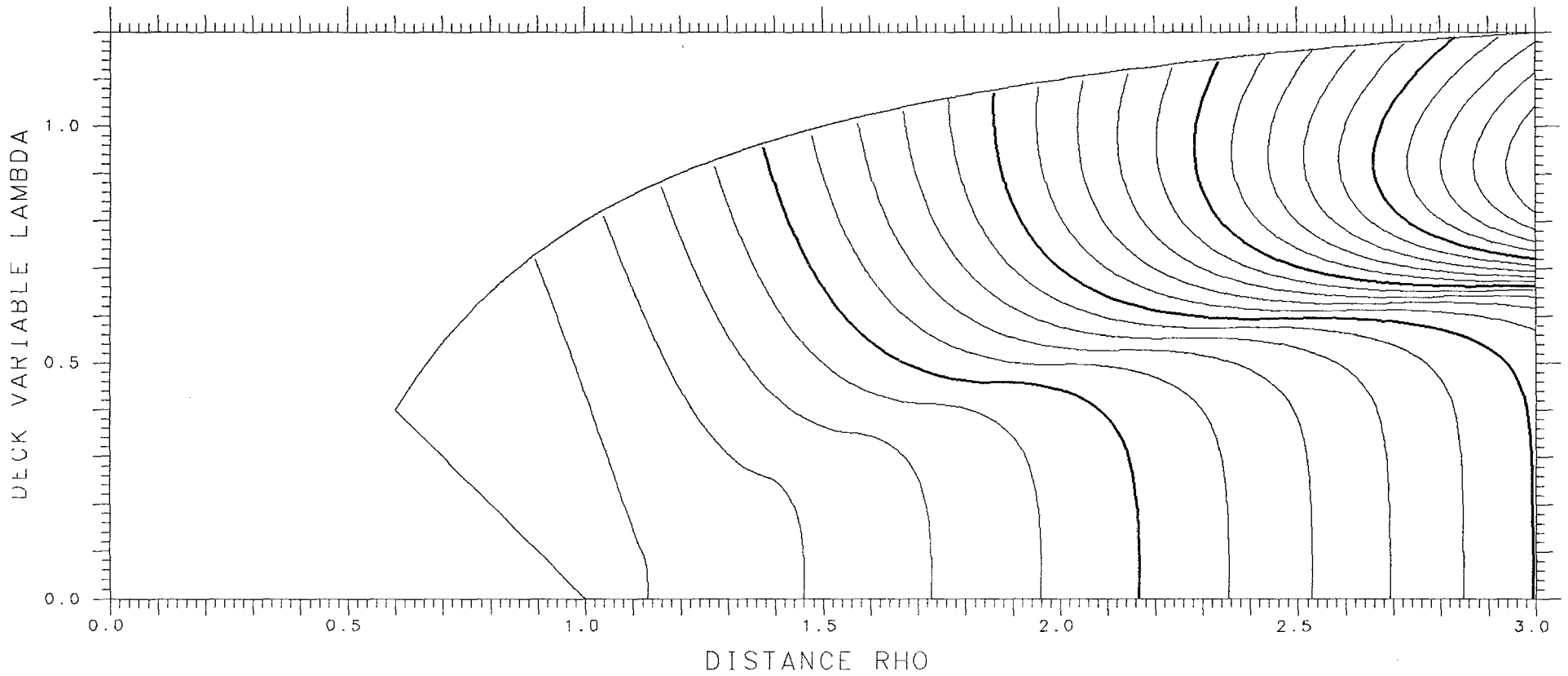

INERTIA PARALLEL ASYMMETRY DELTA=0.

TANGENT .62996 SPACING .01

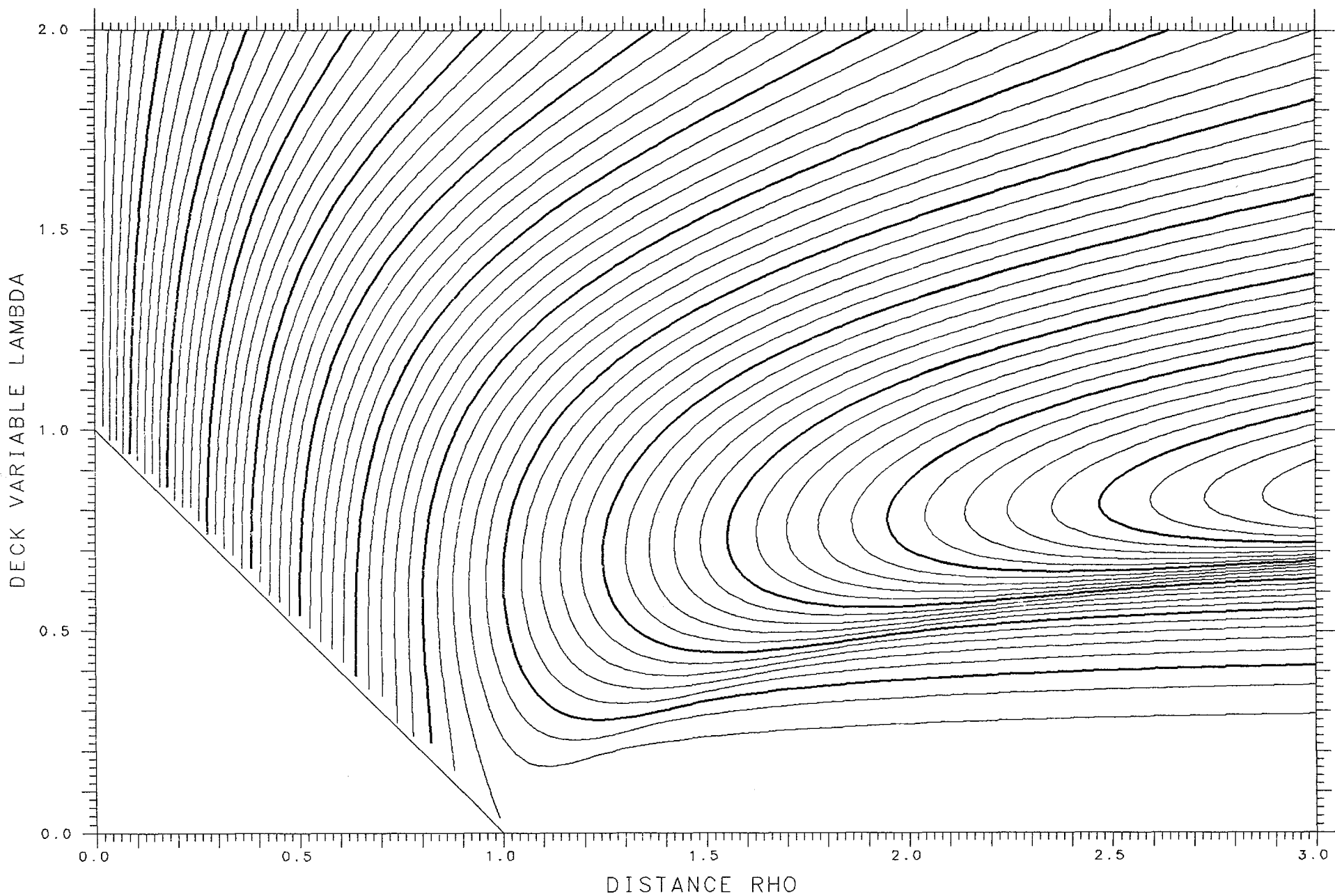

COULOMB ENERGY ASYMMETRY DELTA=0.

SPHERES -.37004 TANGENT -.10756 SPACING .005

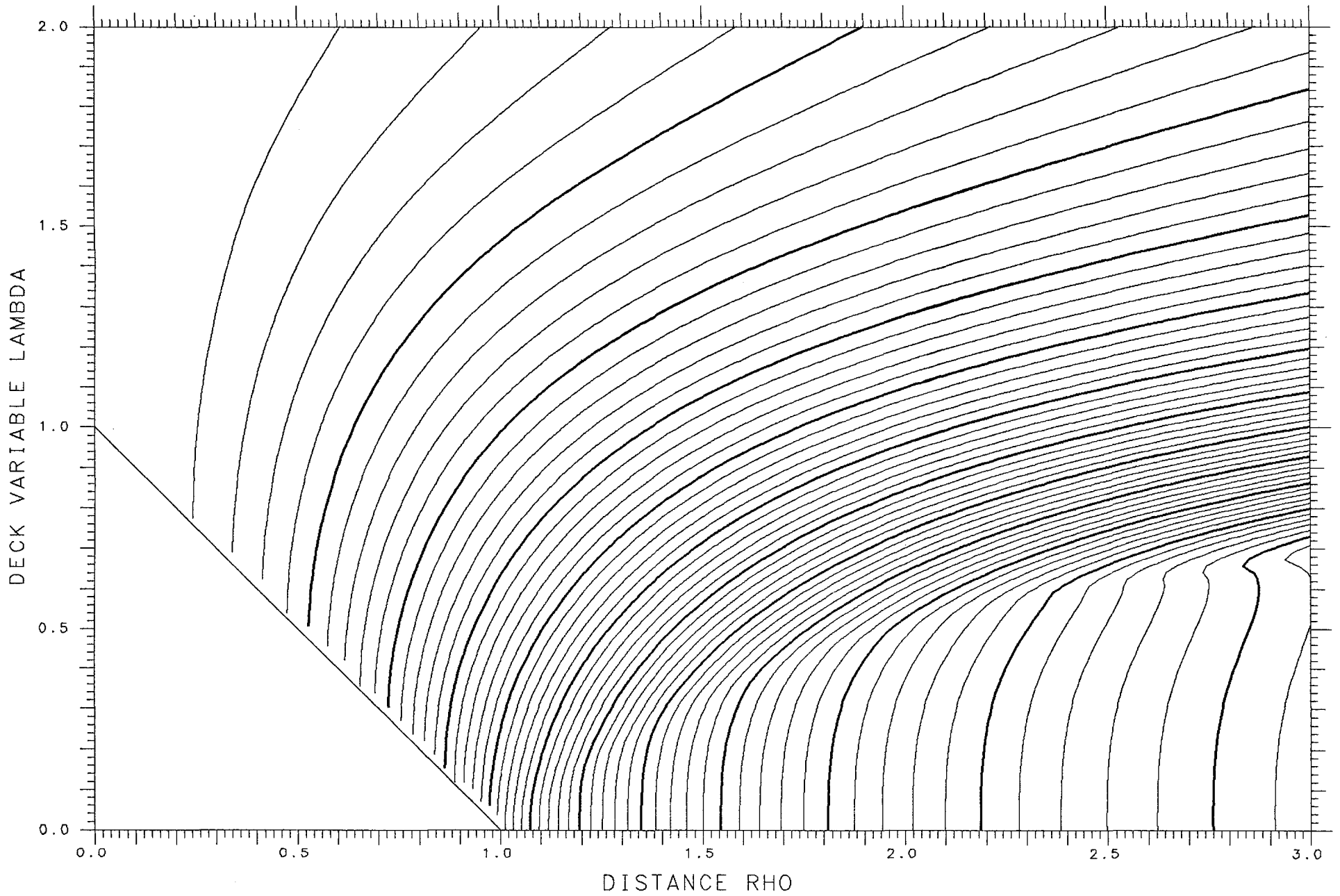

SURFACE ENERGY ASYMMETRY DELTA= .600

SPHERES .05157 TANGENT .05157 SPACING .005

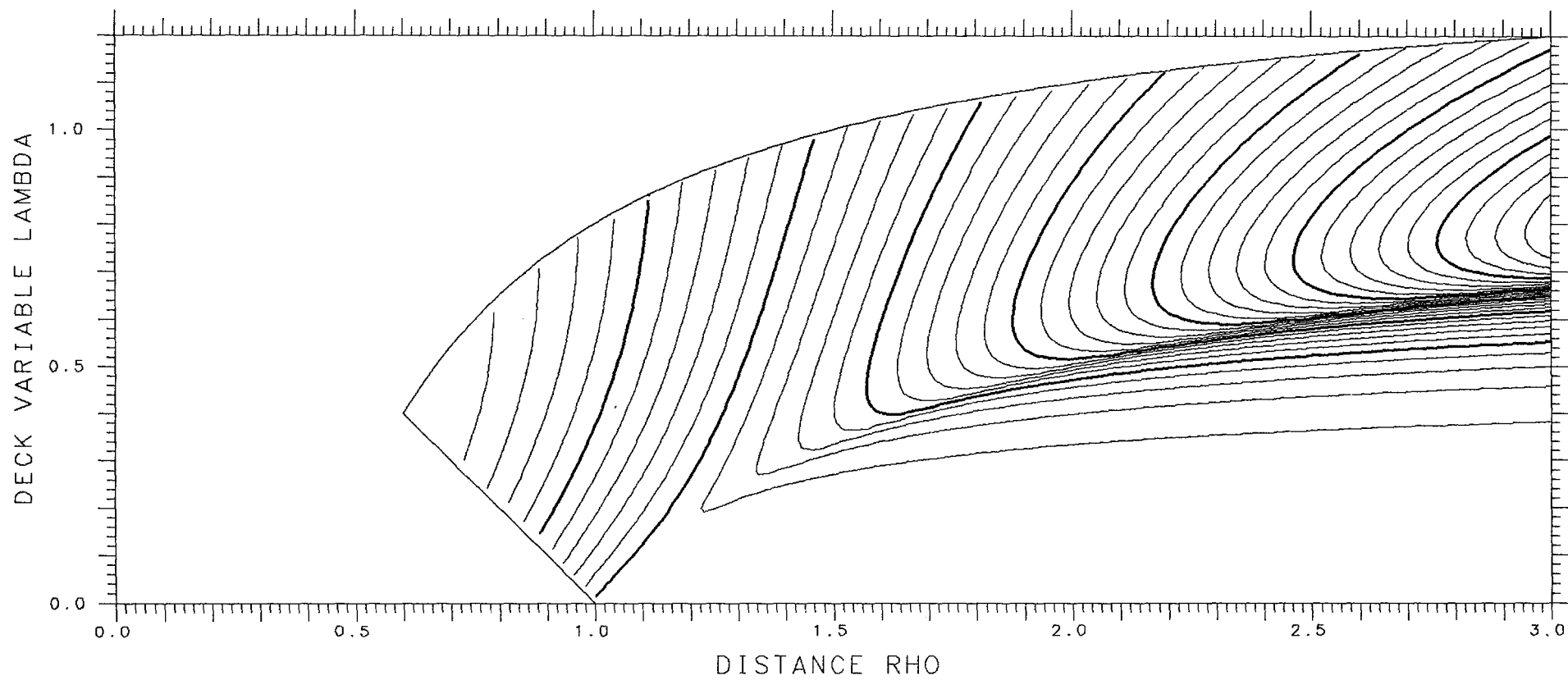

COULOMB ENERGY ASYMMETRY DELTA= .025

SPHERES -.36808 TANGENT -.10690 SPACING .005

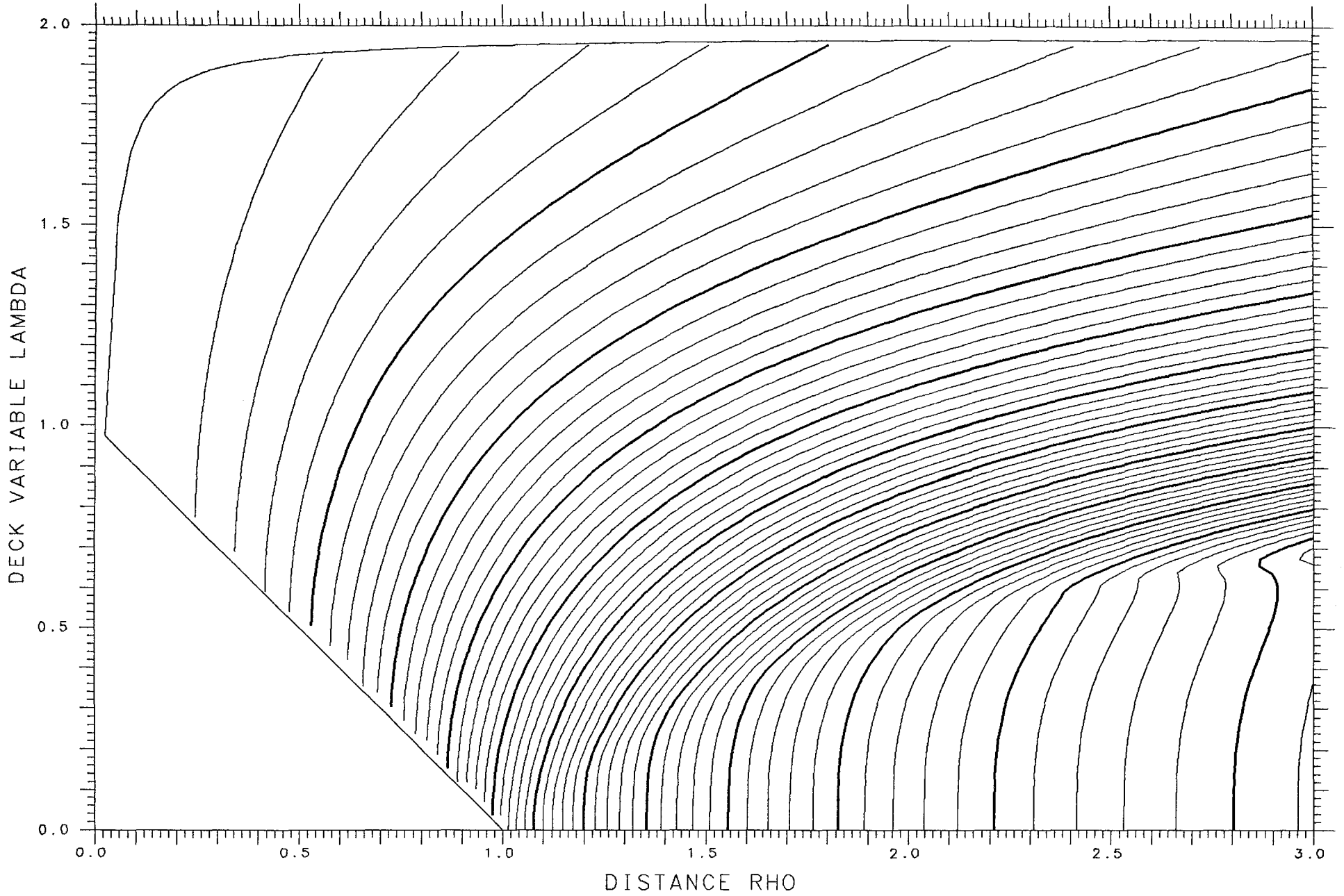

SURFACE ENERGY ASYMMETRY DELTA= .575

SPHERES .05899 TANGENT .05899 SPACING .005

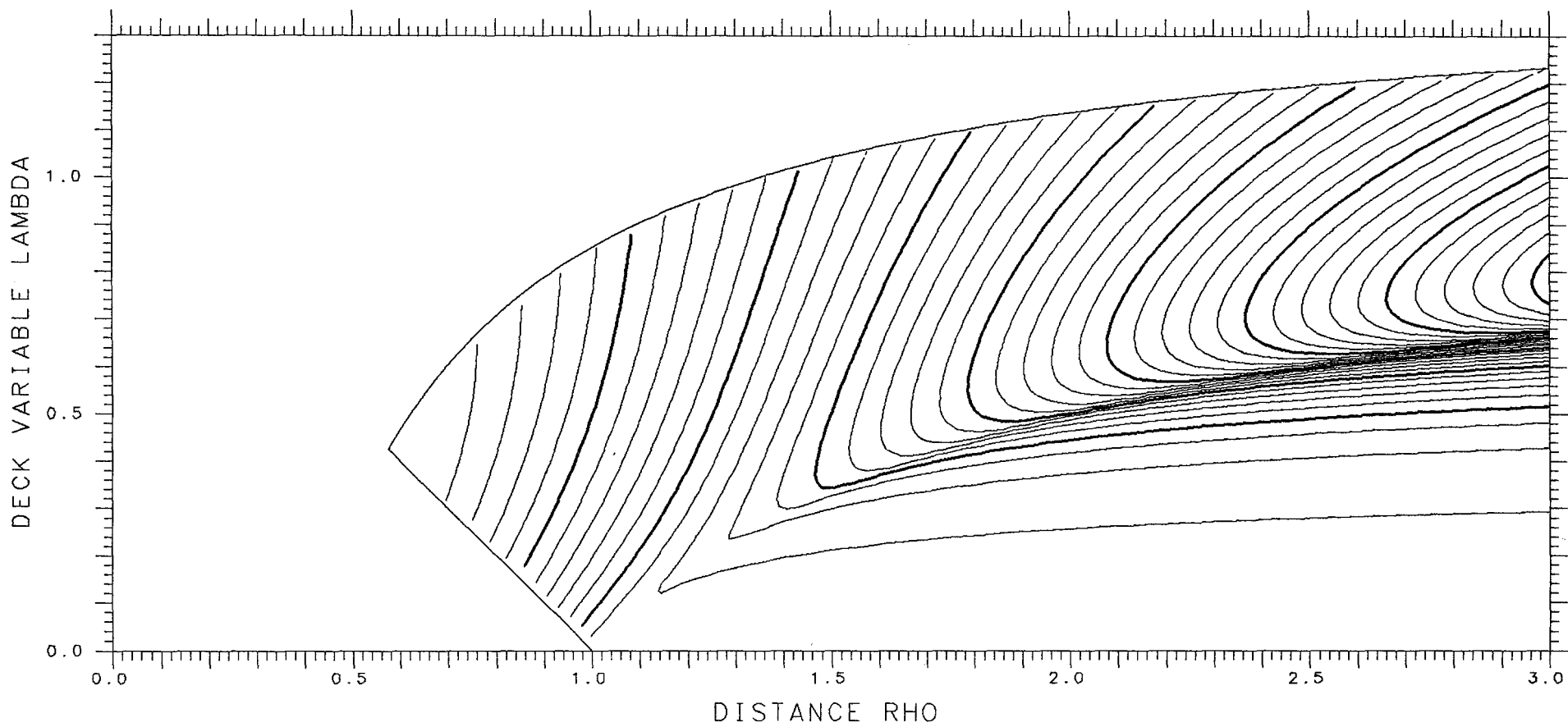

COULOMB ENERGY ASYMMETRY DELTA= .050

SPHERES -.36226 TANGENT -.10497 SPACING .005

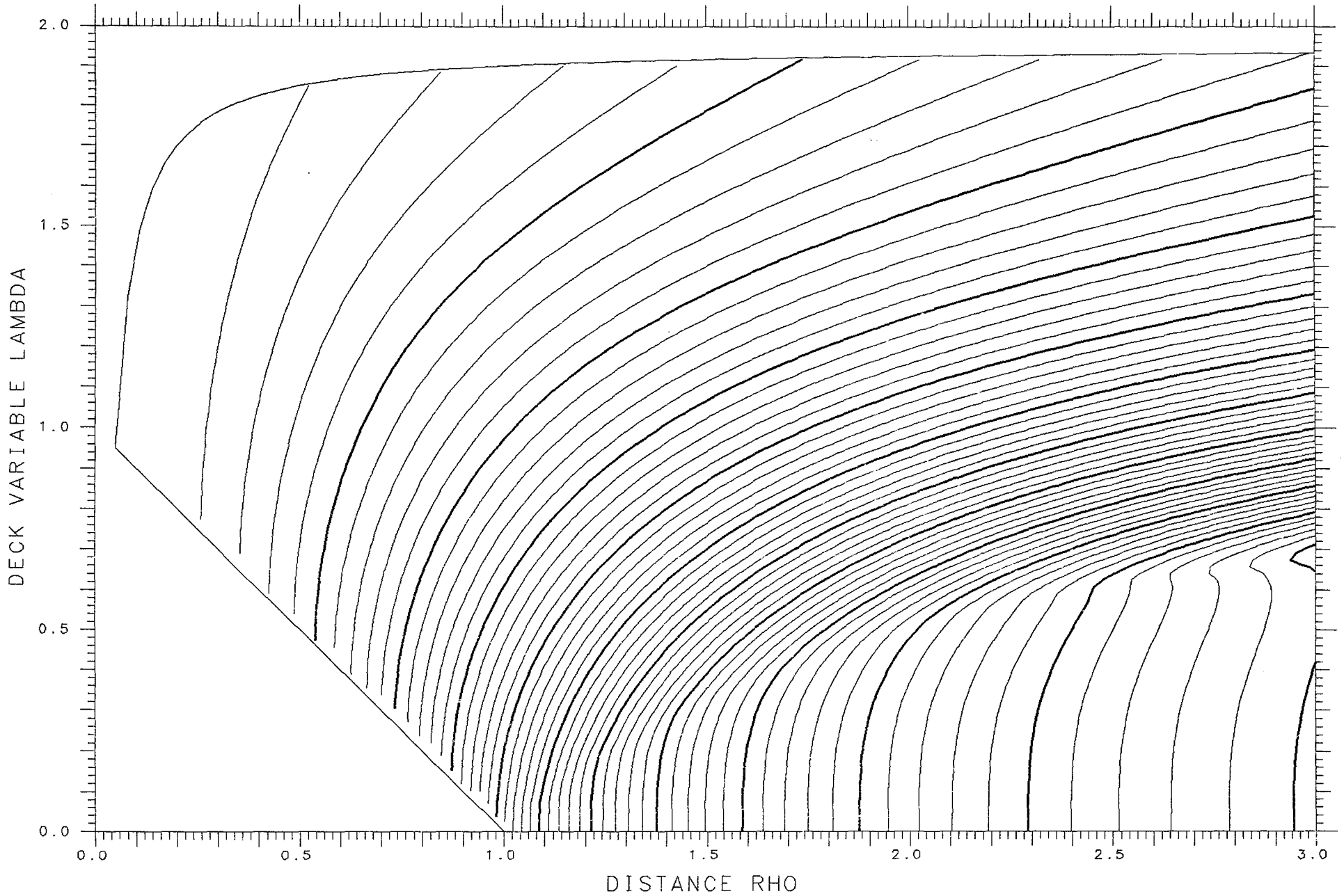

SURFACE ENERGY ASYMMETRY DELTA= .550

SPHERES .06695 TANGENT .06695 SPACING .005

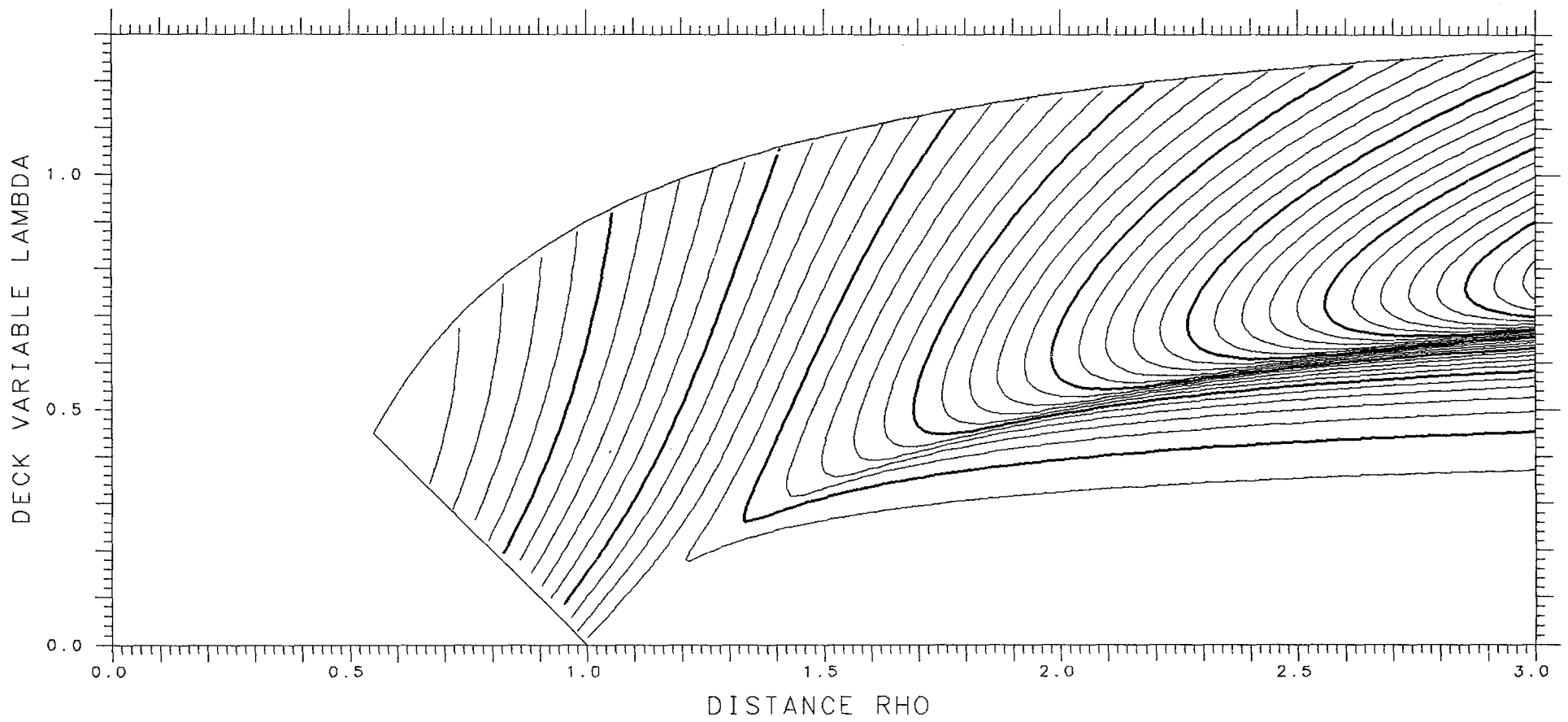

COULOMB ENERGY ASYMMETRY DELTA= .075

SPHERES -.35281 TANGENT -.10183 SPACING .005

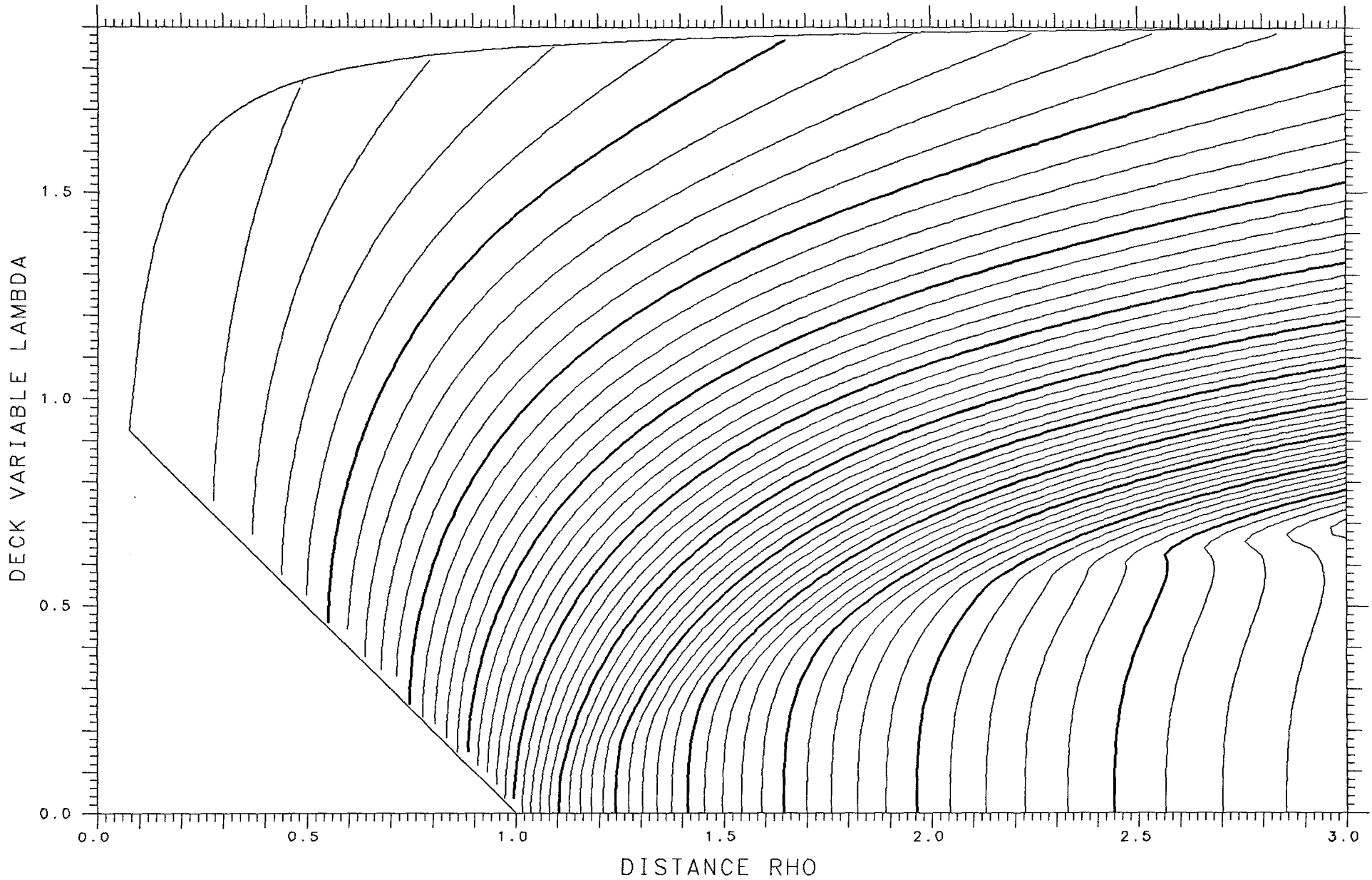

SURFACE ENERGY ASYMMETRY DELTA= .525

SPHERES .07546 TANGENT .07546 SPACING .005

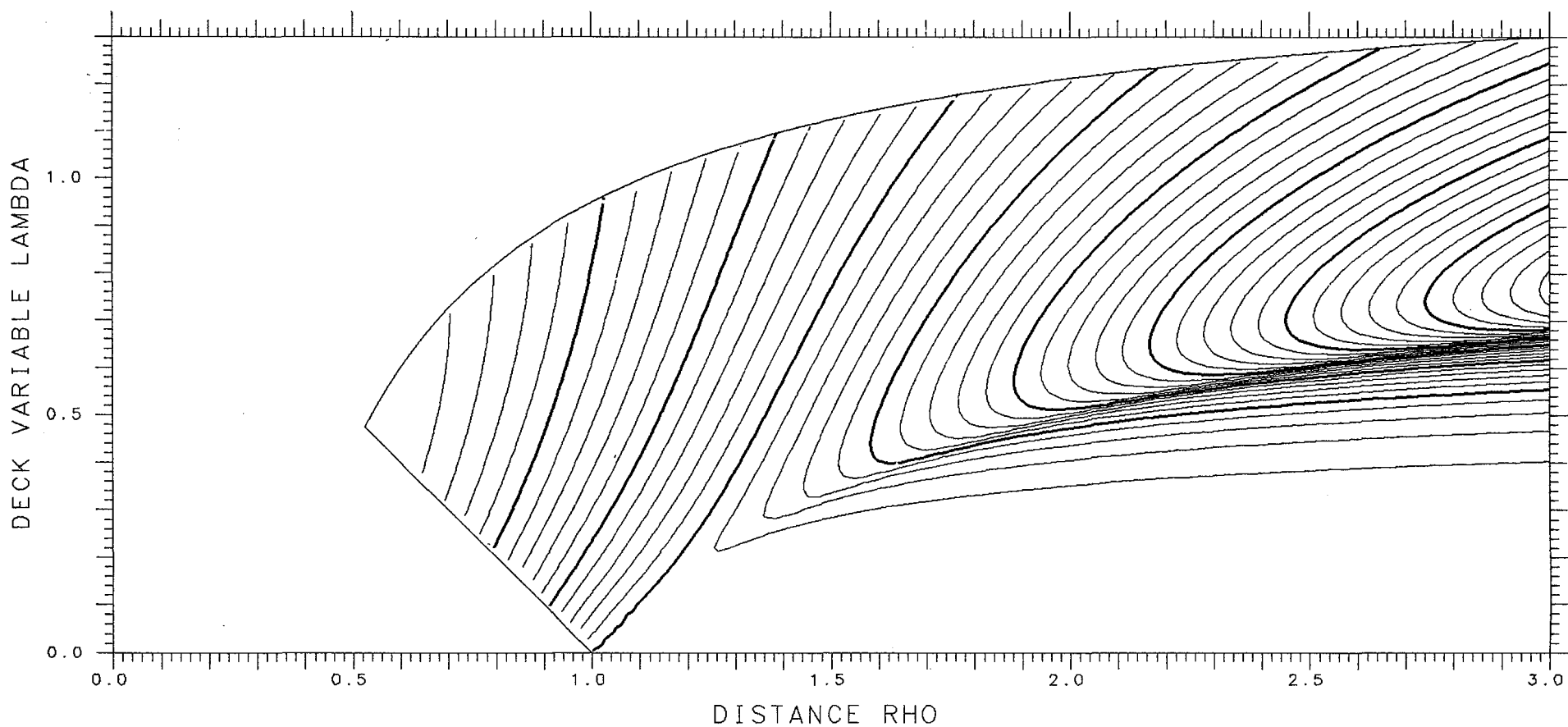

COULOMB ENERGY ASYMMETRY DELTA= .100

SPHERES -.34005 TANGENT -.09761 SPACING .005

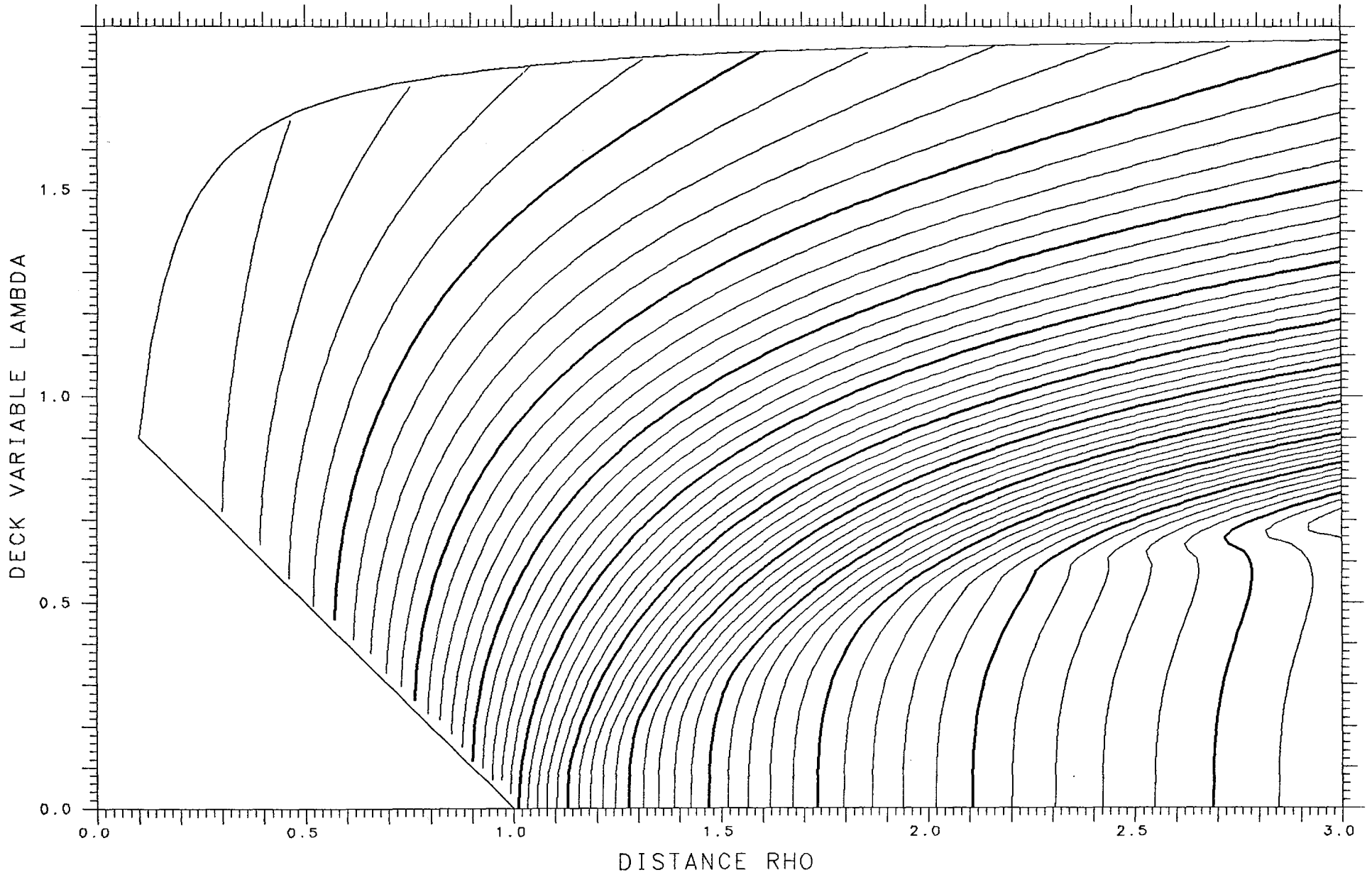

SURFACE ENERGY ASYMMETRY DELTA= .500

SPHERES .08450 TANGENT .08450 SPACING .005

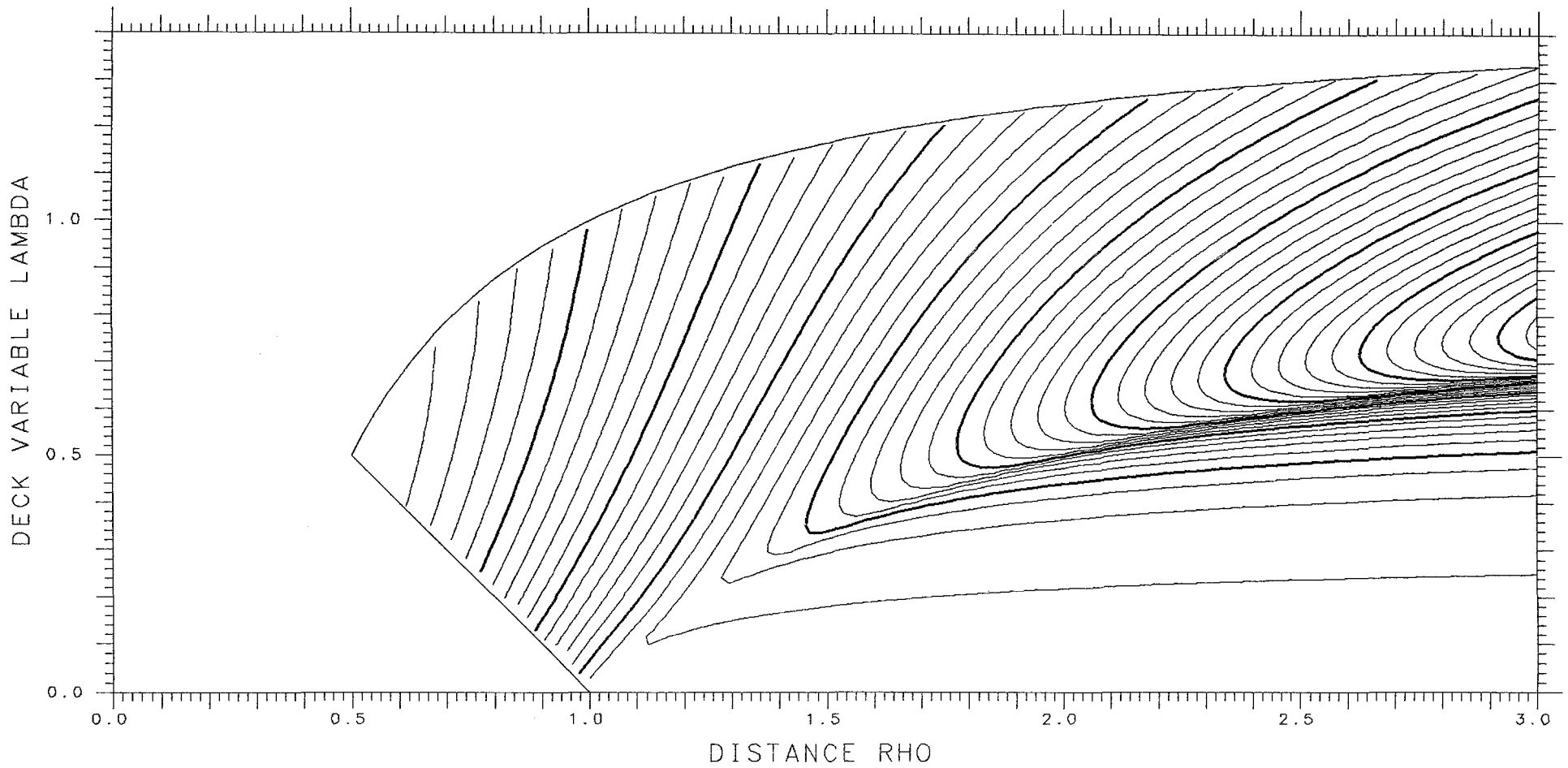

COULOMB ENERGY ASYMMETRY DELTA= .125

SPHERES -.32444 TANGENT -.09247 SPACING .005

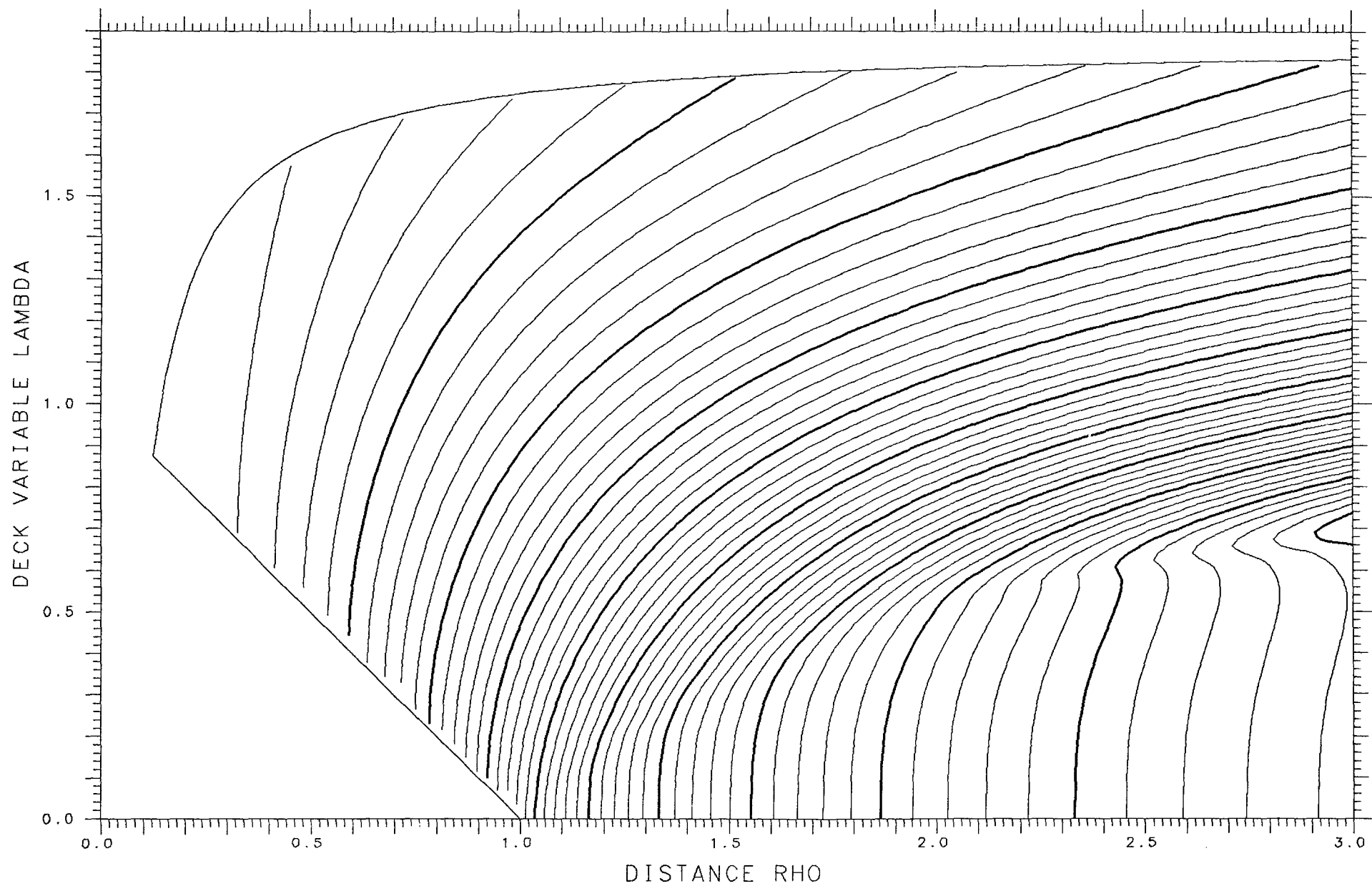

SURFACE ENERGY ASYMMETRY DELTA= .475

SPHERES .09404 TANGENT .09404 SPACING .005

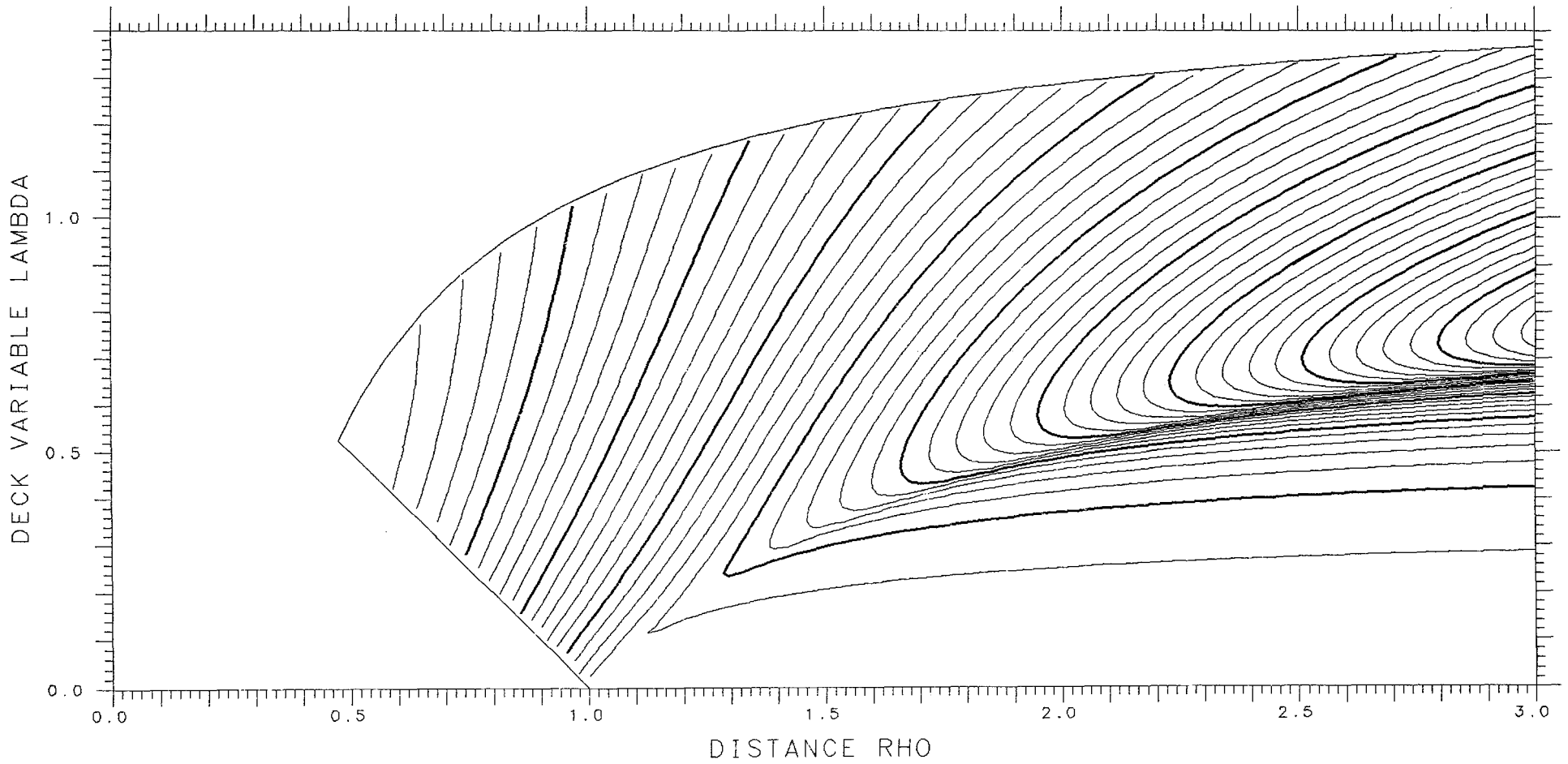

COULOMB ENERGY ASYMMETRY DELTA= .150

SPHERES -.30647 TANGENT -.08660 SPACING .005

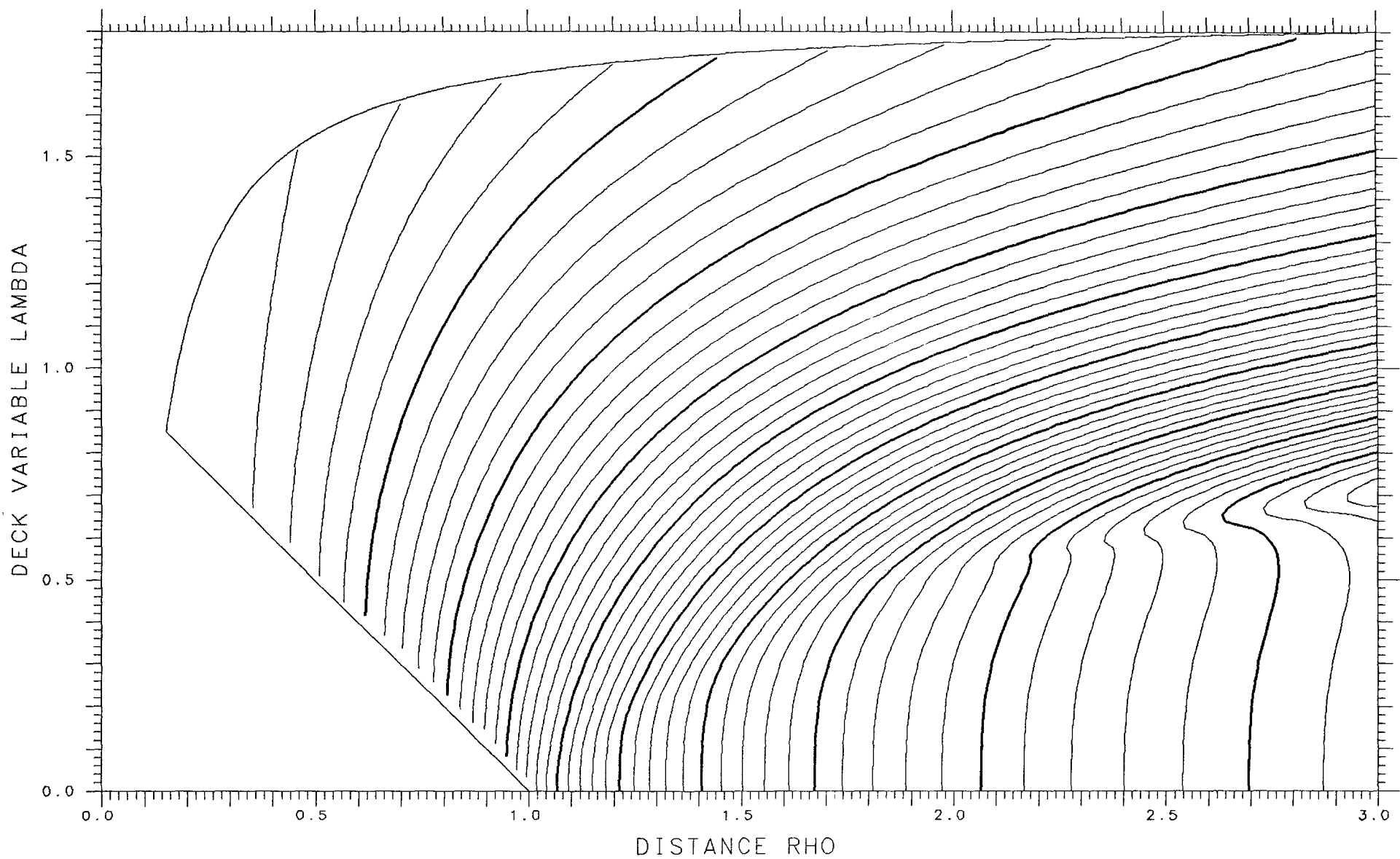

SURFACE ENERGY ASYMMETRY DELTA= .450

SPHERES .10406 TANGENT .10406 SPACING .005

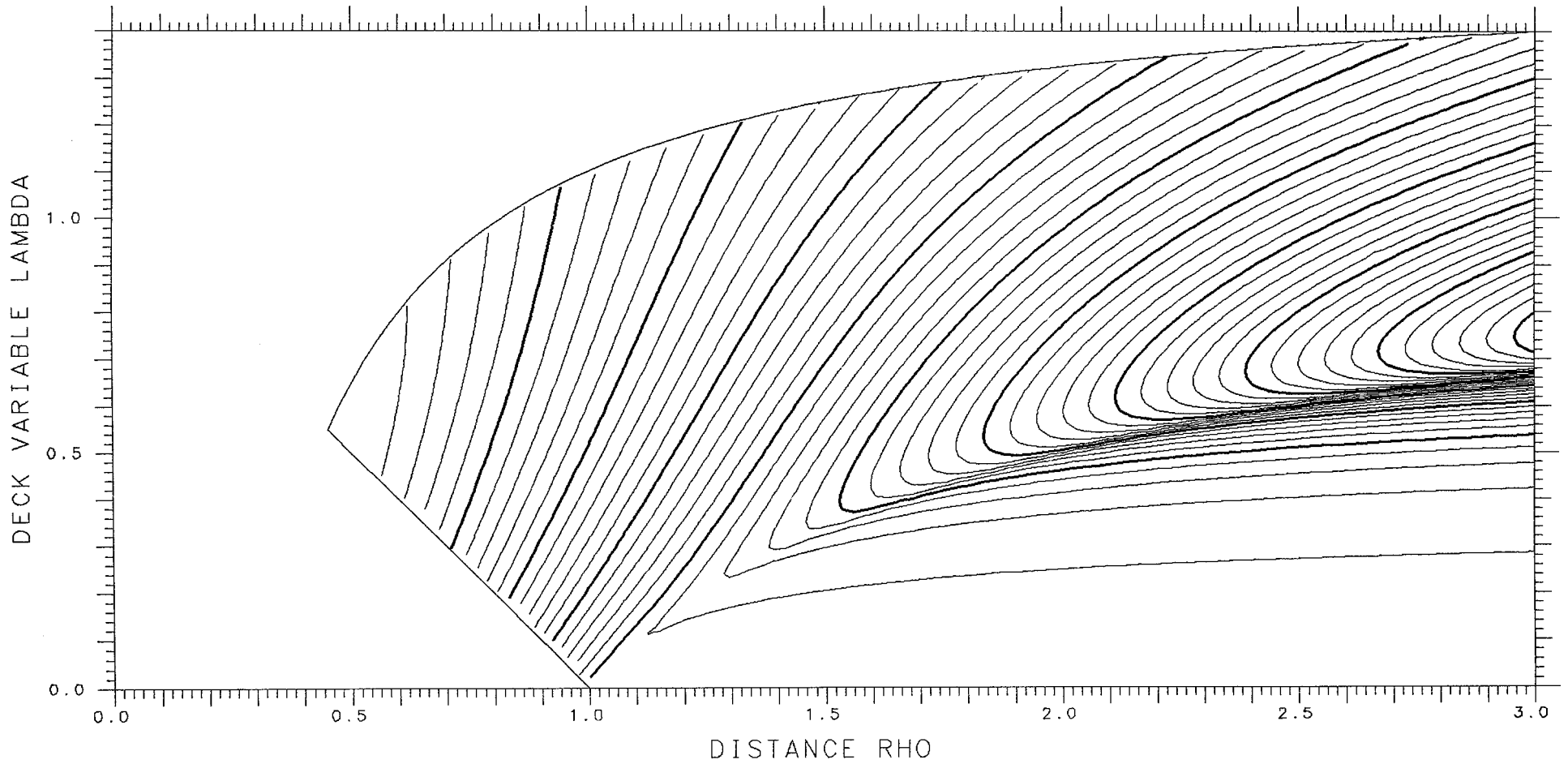

COULOMB ENERGY ASYMMETRY DELTA= .175

SPHERES -.28670 TANGENT -.08018 SPACING .005

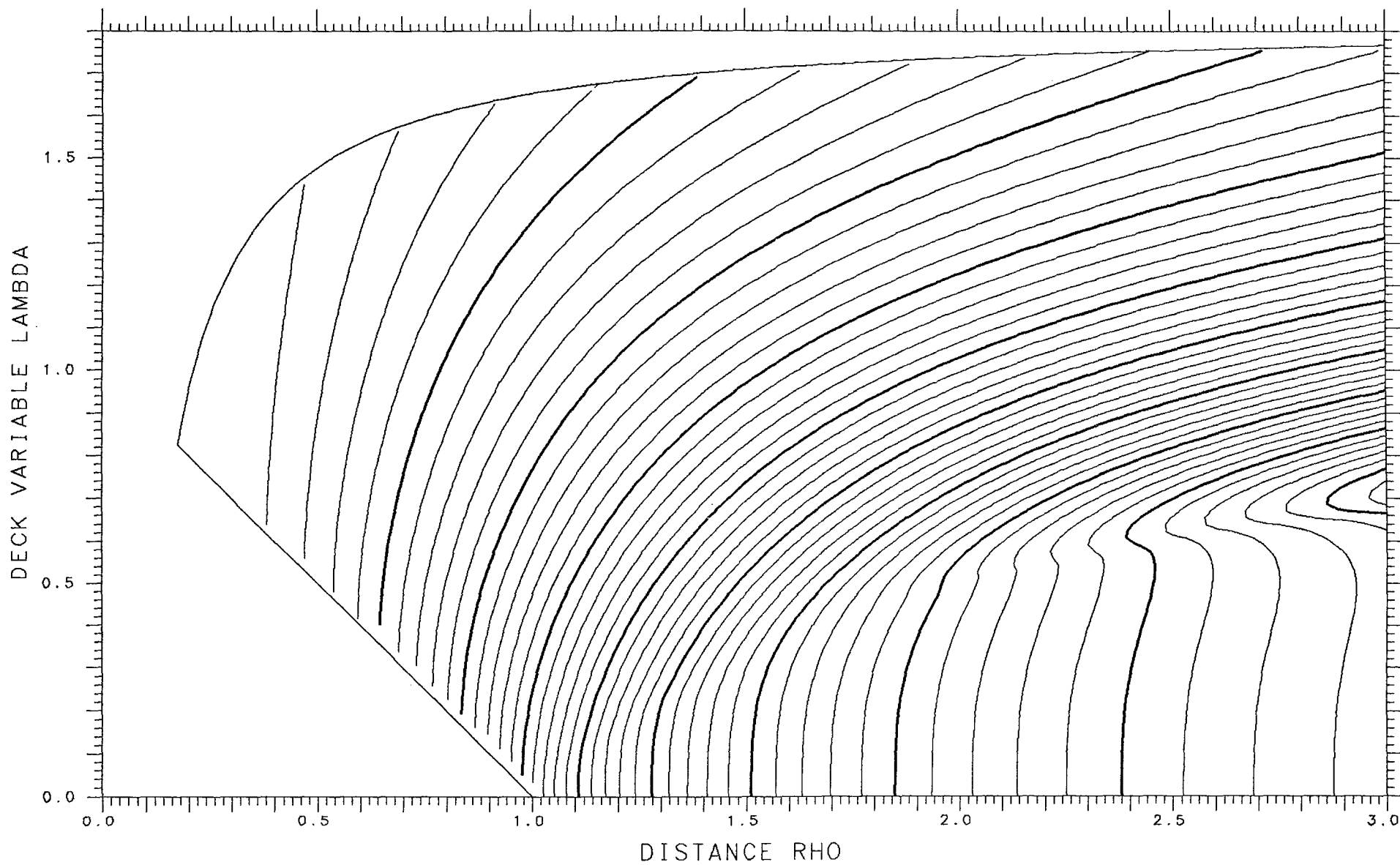

SURFACE ENERGY ASYMMETRY DELTA= .425

SPHERES .11452 TANGENT .11452 SPACING .005

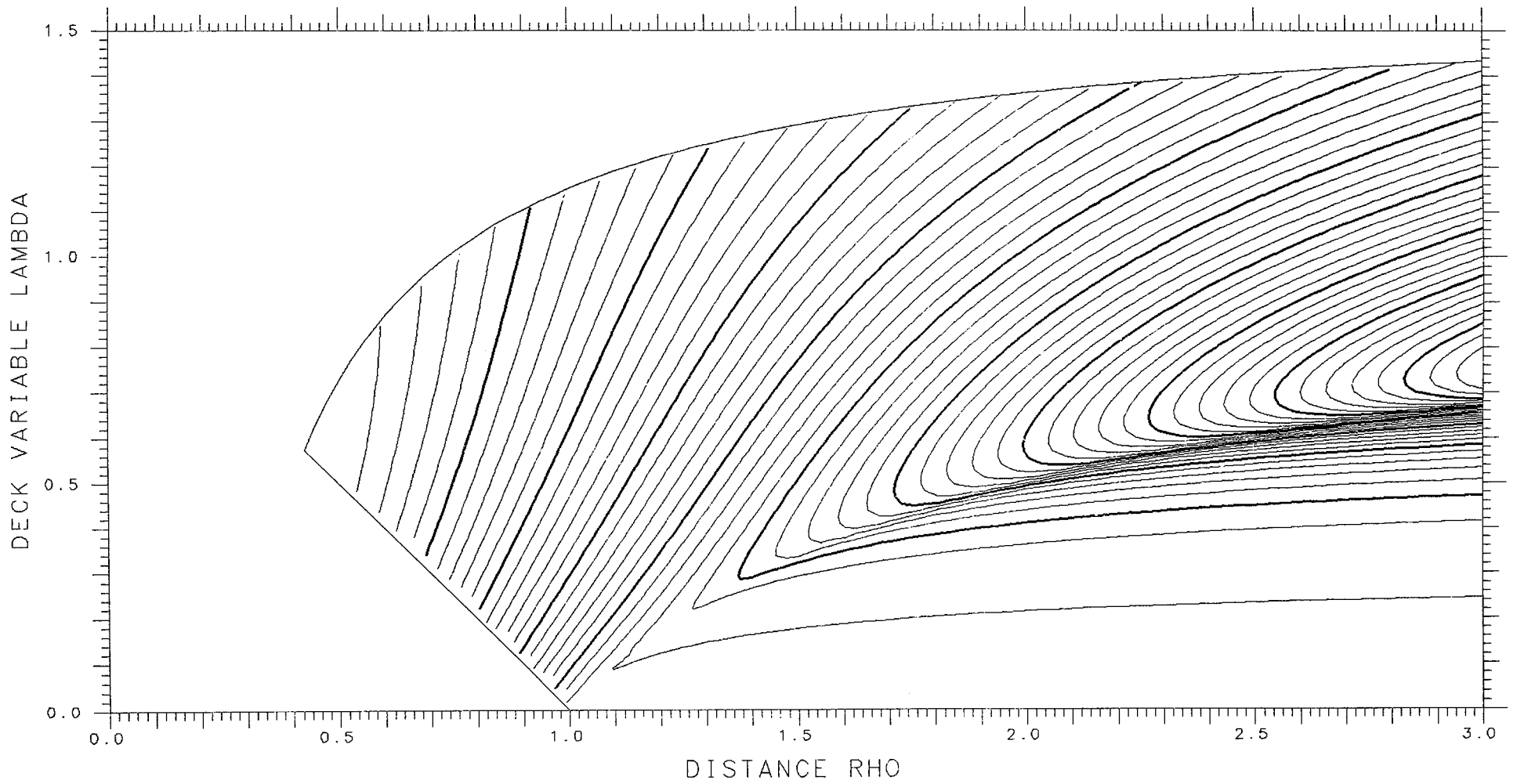

COULOMB ENERGY ASYMMETRY DELTA= .200

SPHERES -.26568 TANGENT -.07342 SPACING .005

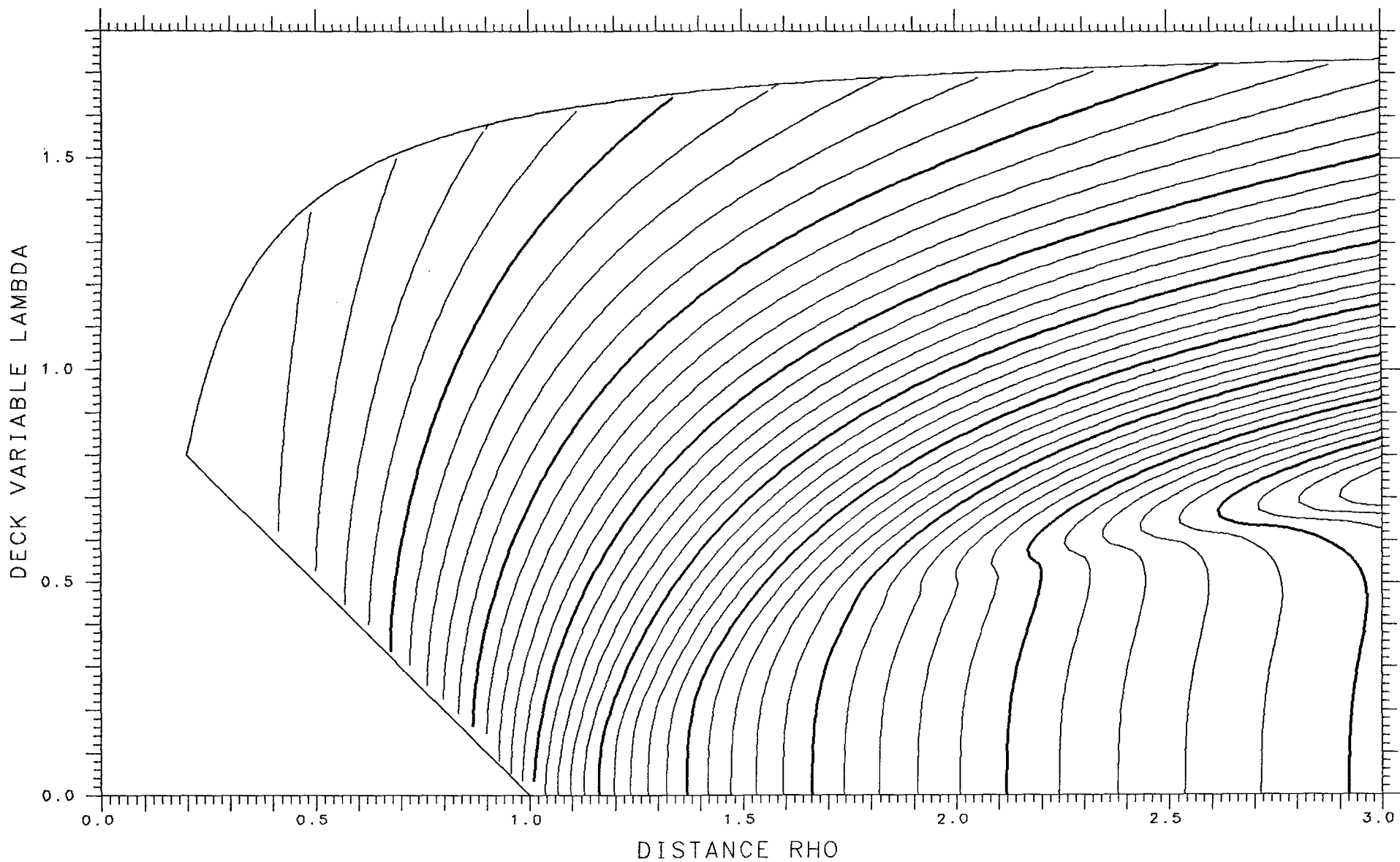

SURFACE ENERGY ASYMMETRY DELTA= .400

SPHERES .12537 TANGENT .12537 SPACING .005

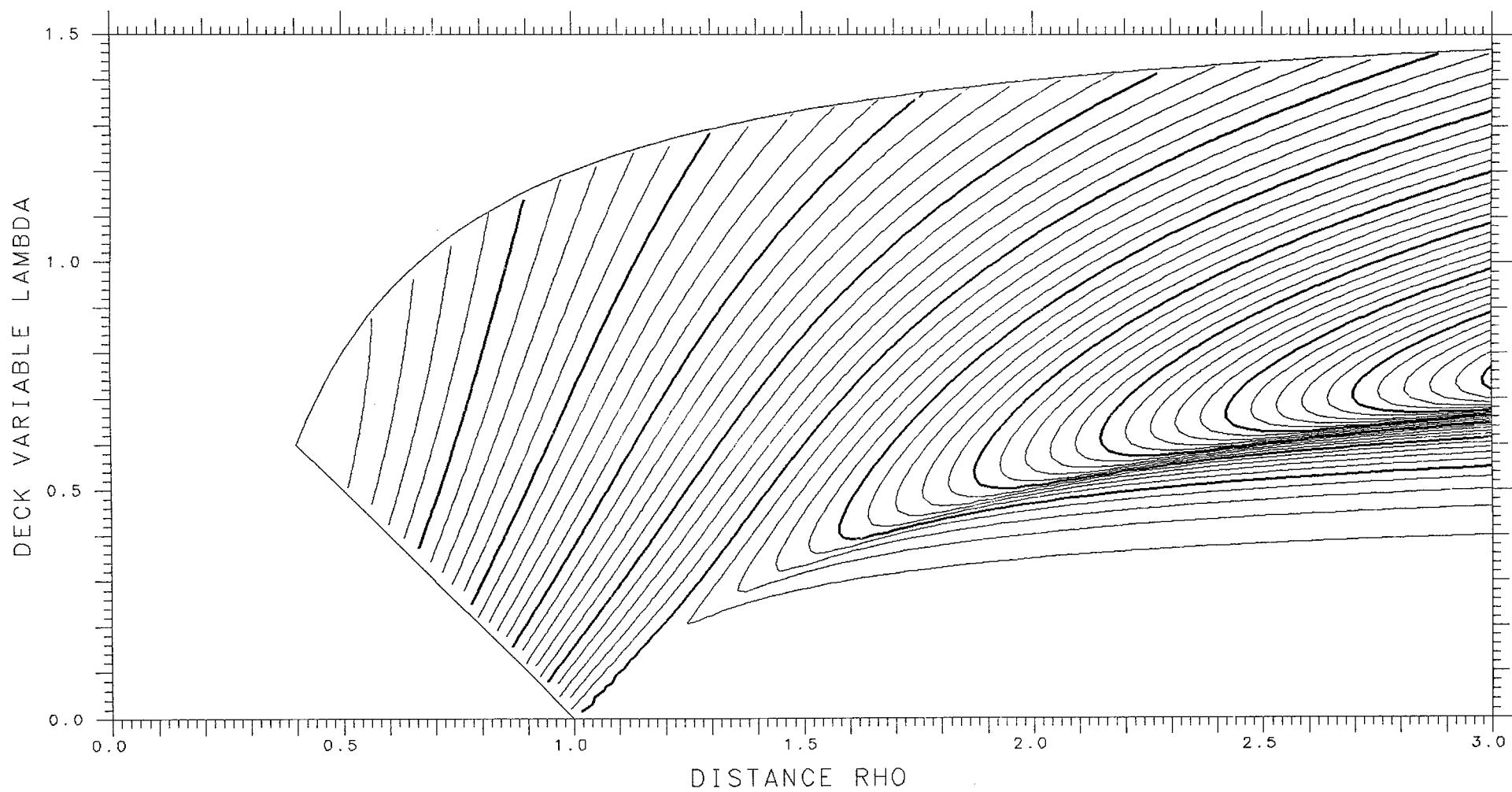

COULOMB ENERGY ASYMMETRY DELTA= .225

SPHERES -.24396 TANGENT -.06651 SPACING .005

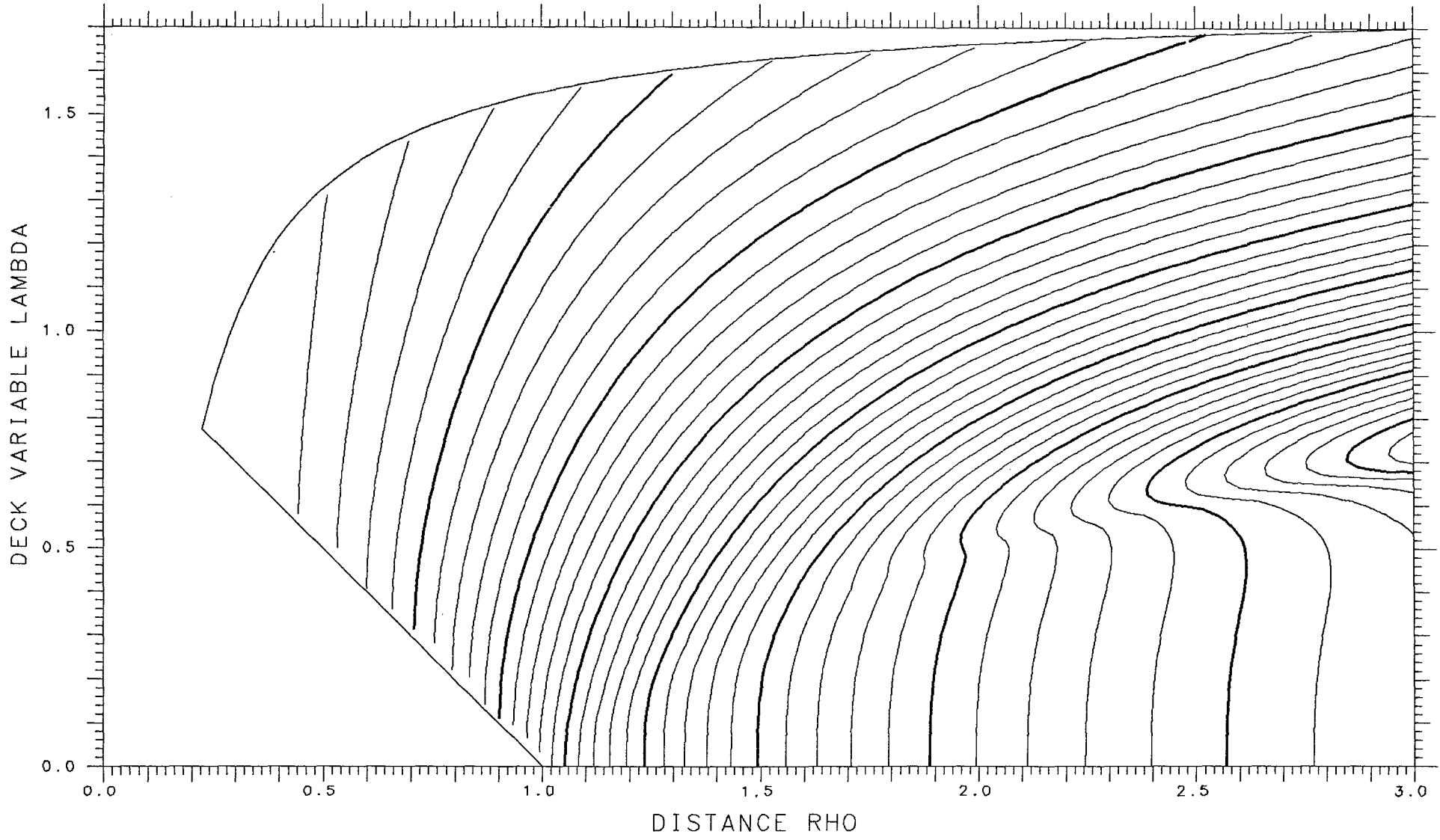

SURFACE ENERGY ASYMMETRY DELTA= .375

SPHERES .13652 TANGENT .13652 SPACING .005

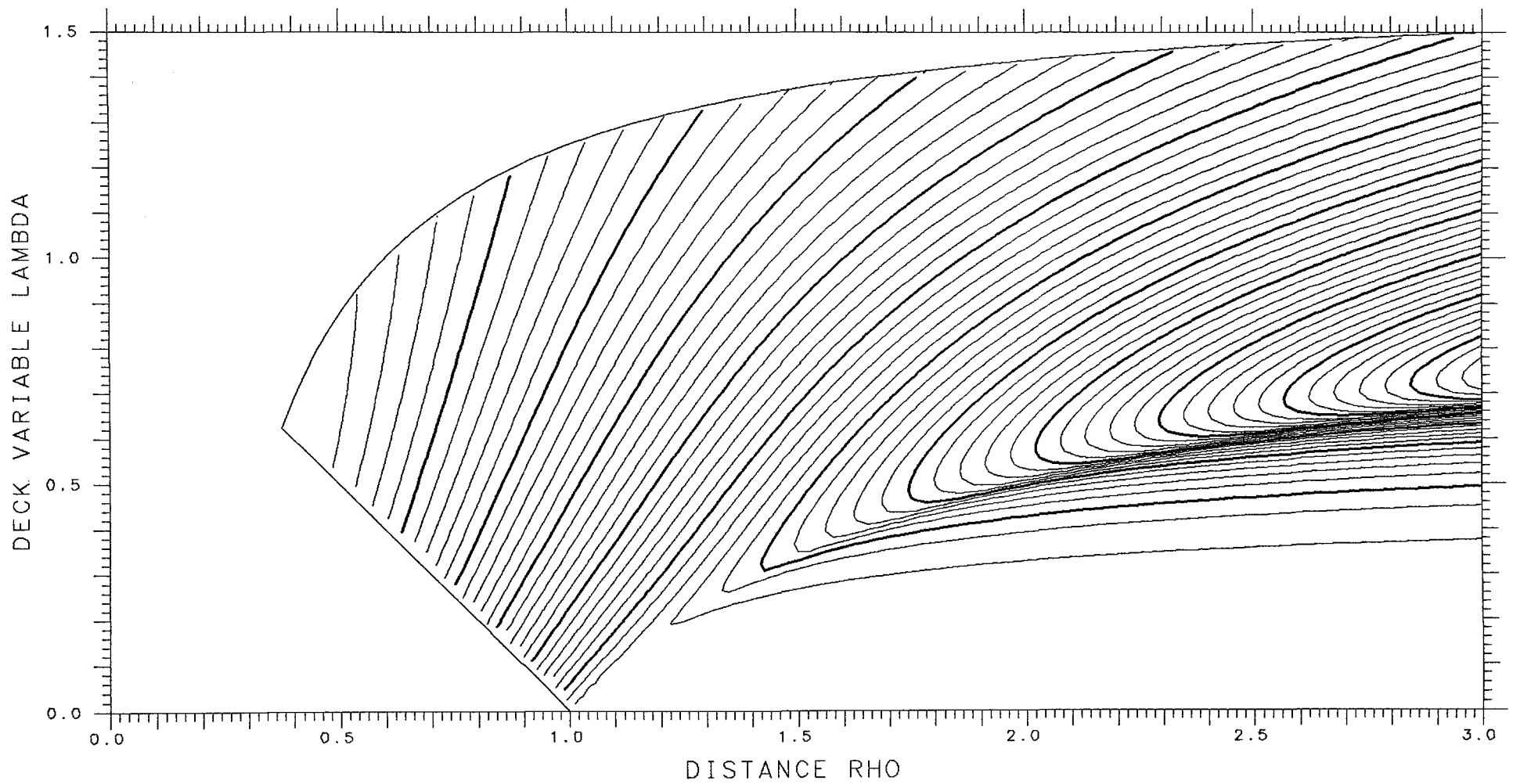

COULOMB ENERGY ASYMMETRY DELTA= .250

SPHERES -.22202 TANGENT -.05961 SPACING .005

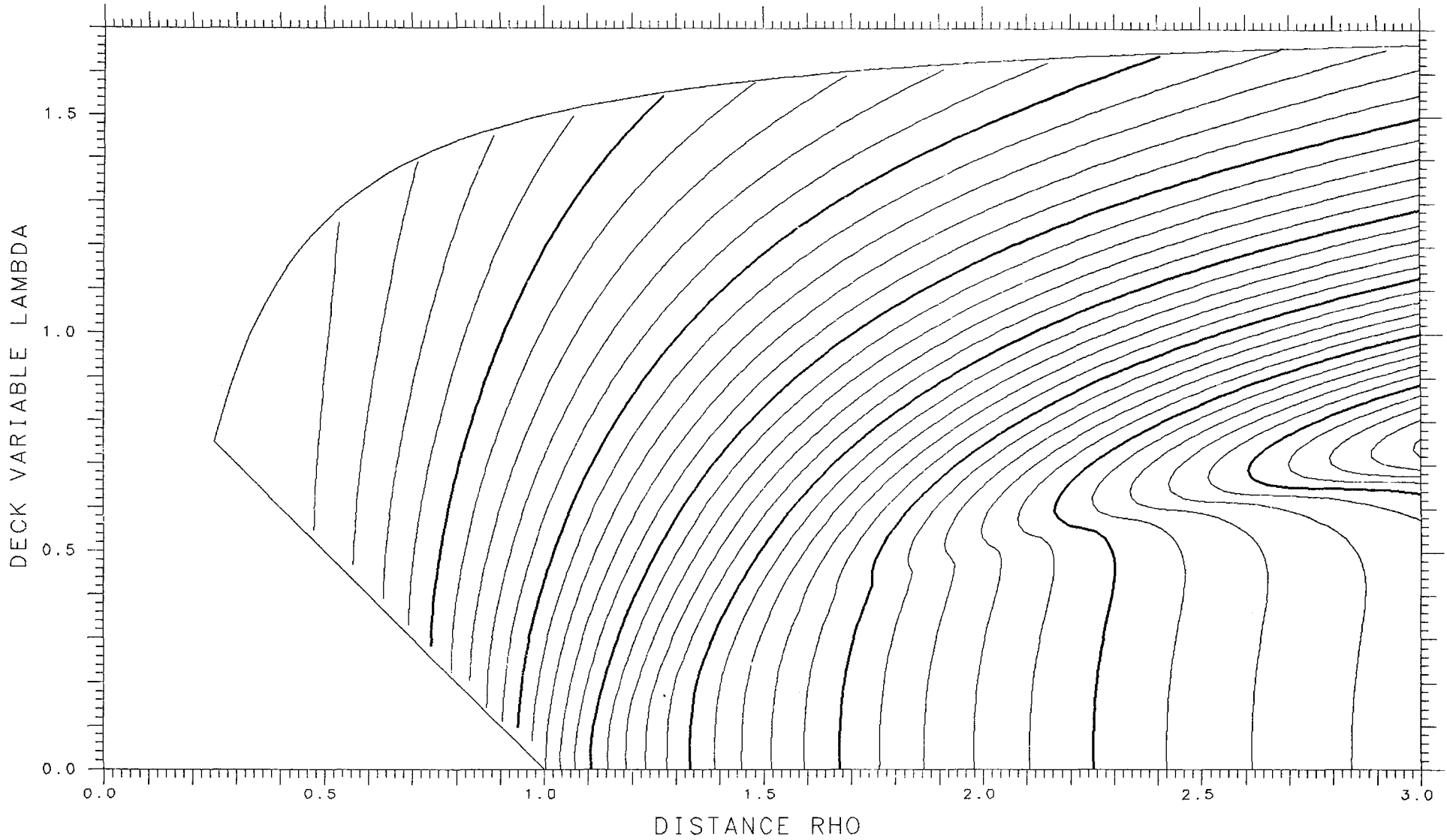

SURFACE ENERGY ASYMMETRY DELTA= .350

SPHERES .14792 TANGENT .14792 SPACING .005

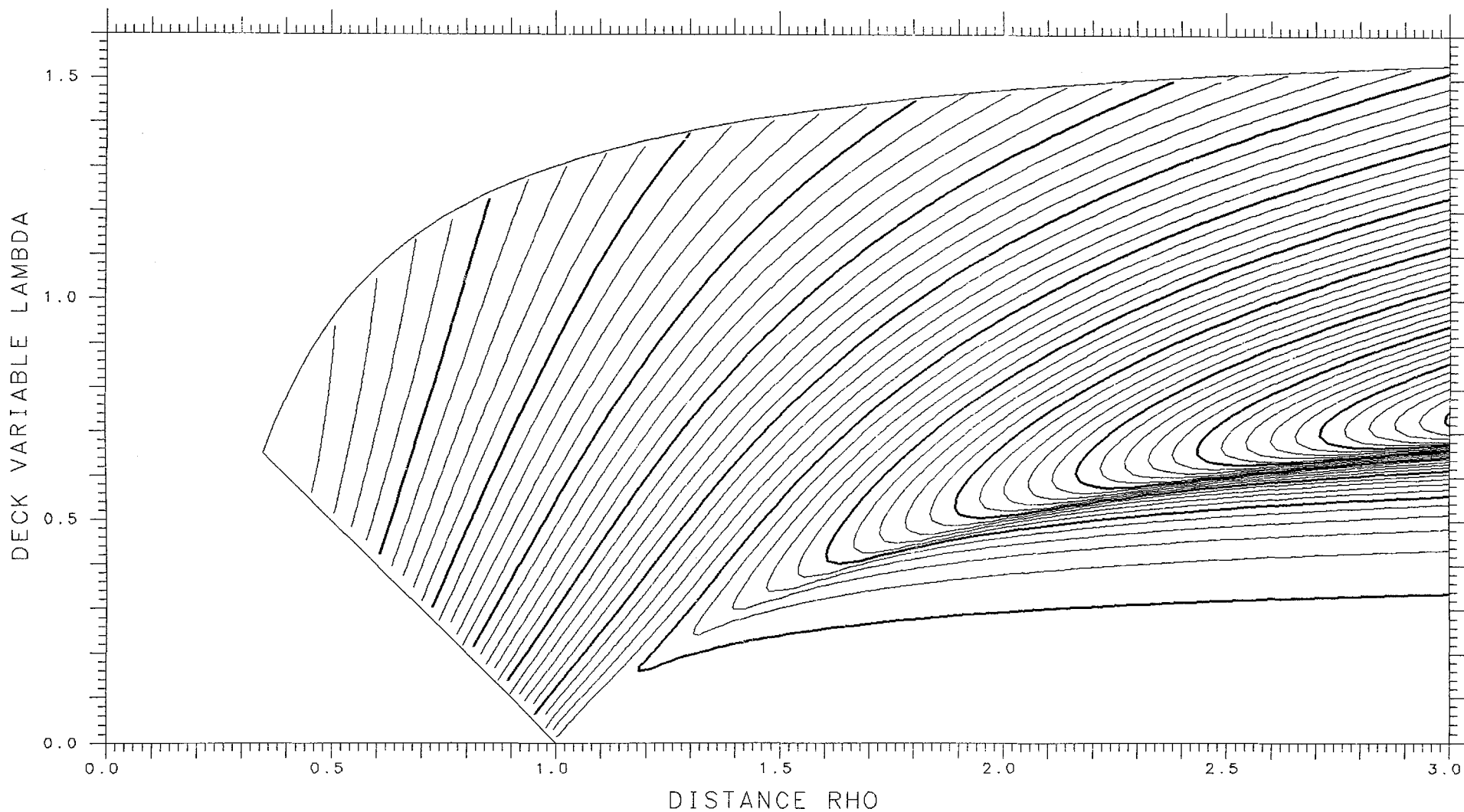

COULOMB ENERGY ASYMMETRY DELTA= .275

SPHERES -.20033 TANGENT -.05287 SPACING .005

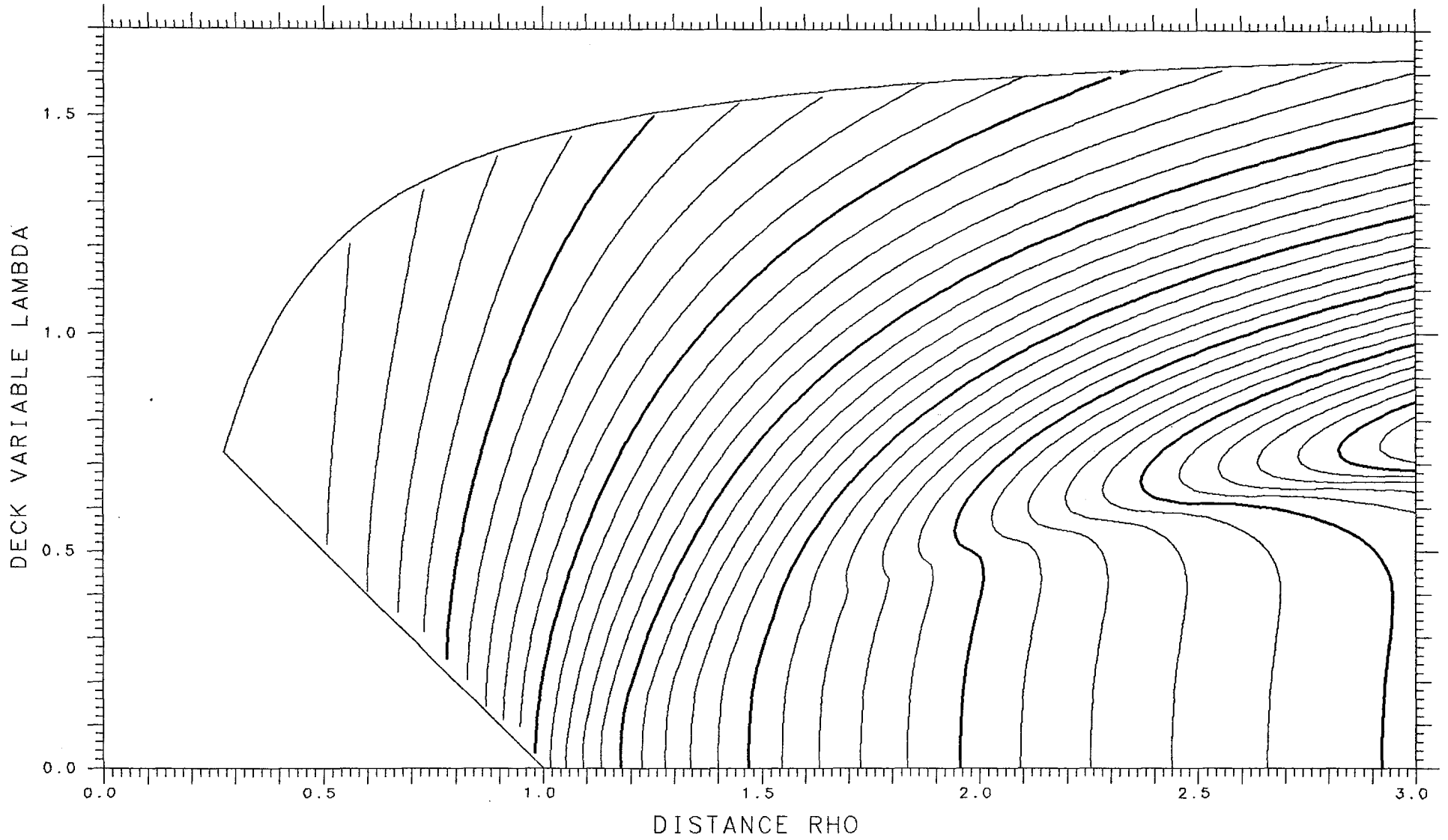

SURFACE ENERGY ASYMMETRY DELTA= .325

SPHERES .15946 TANGENT .15946 SPACING .005

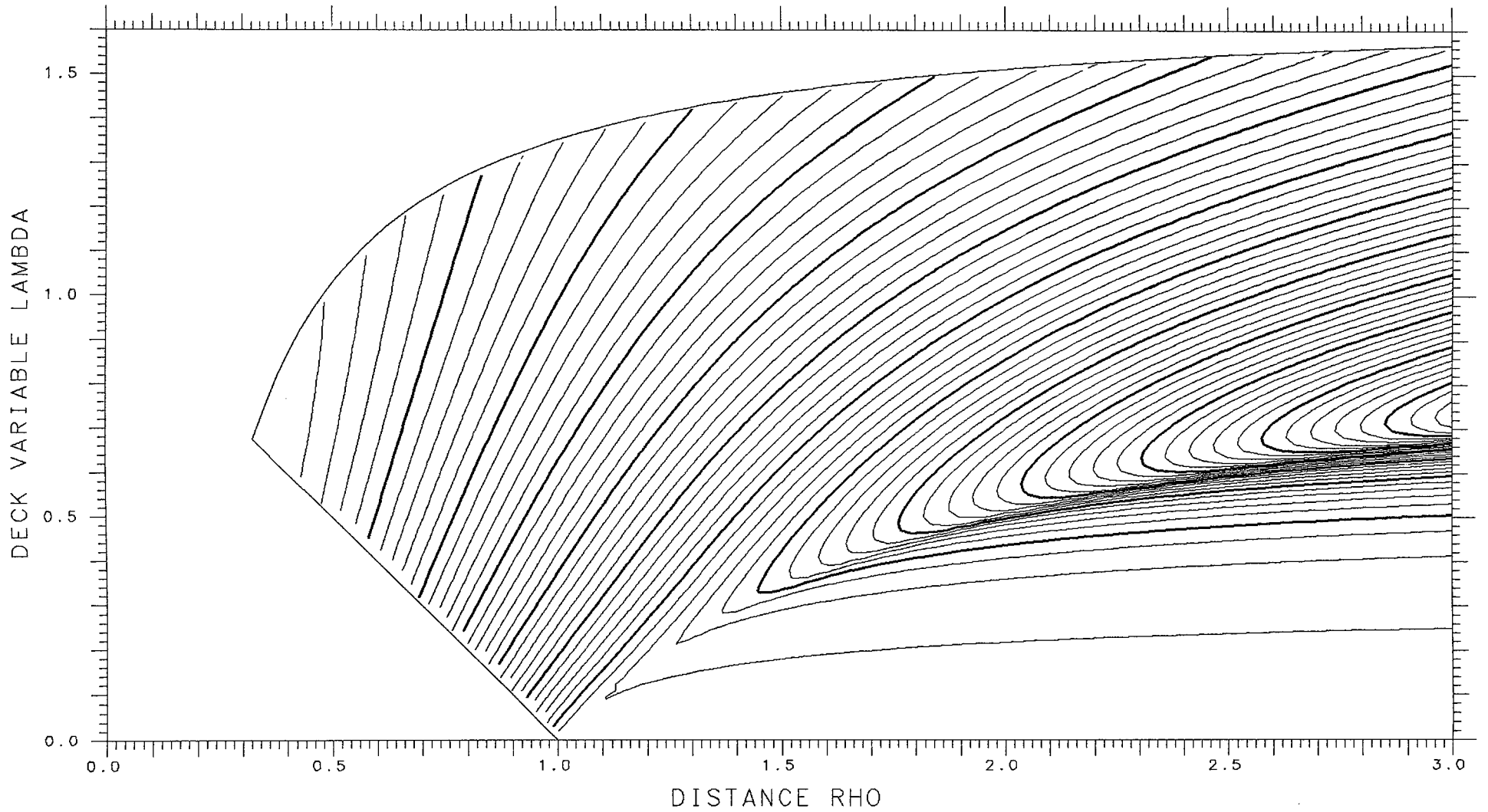

COULOMB ENERGY ASYMMETRY DELTA= .300

SPHERES -.17923 TANGENT -.04642 SPACING .002

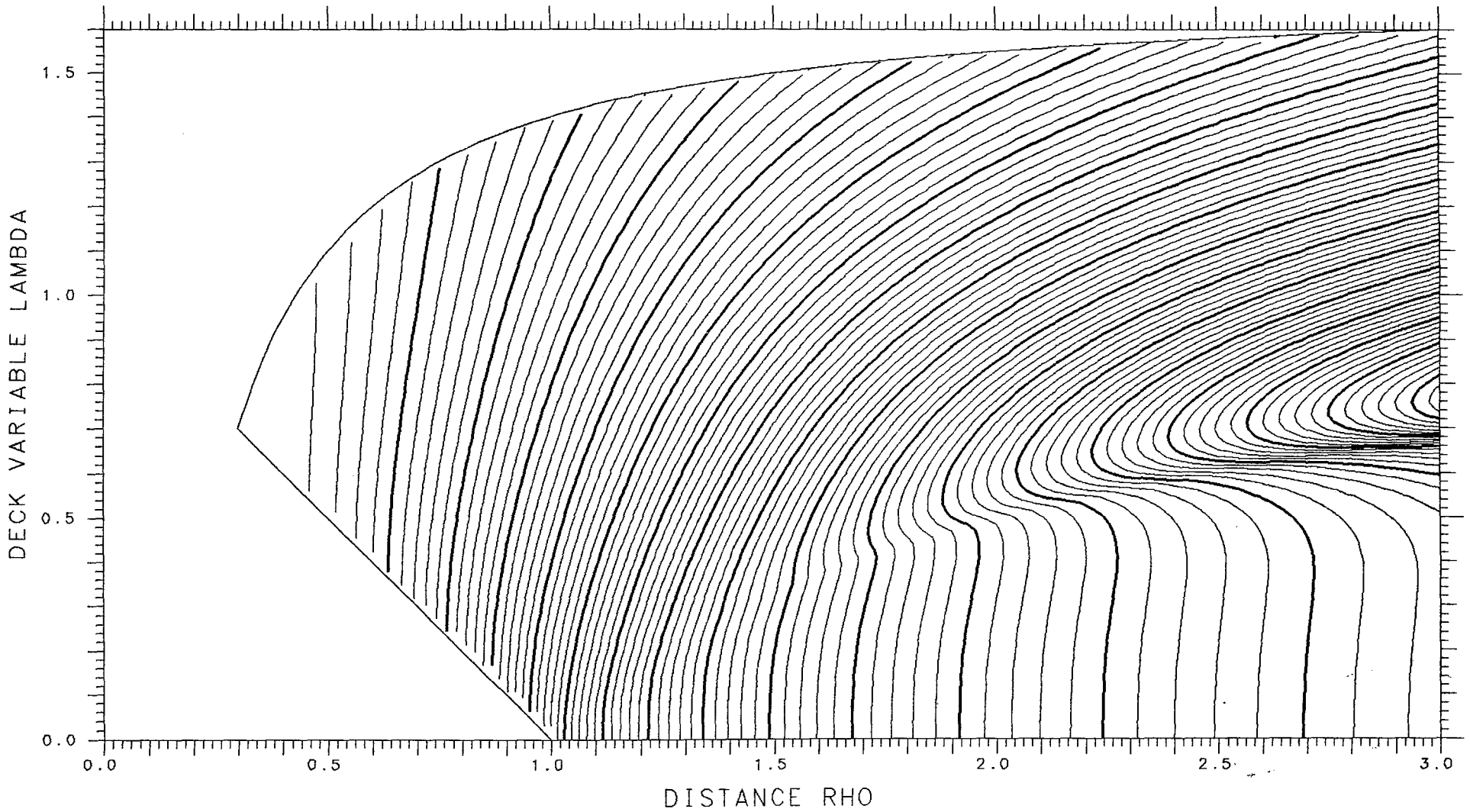

SURFACE ENERGY ASYMMETRY DELTA= .300

SPHERES .17103 TANGENT .17103 SPACING .005

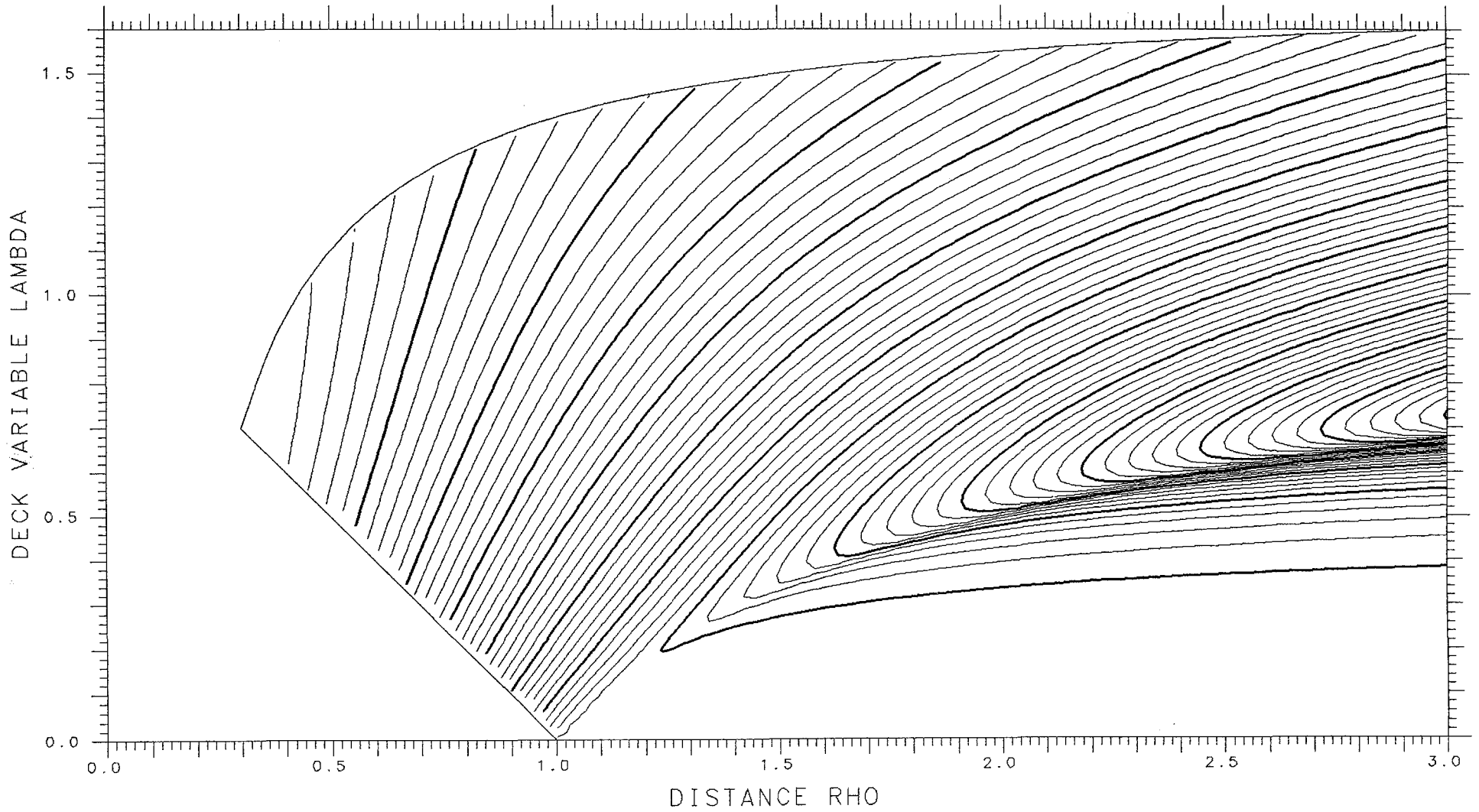

COULOMB ENERGY ASYMMETRY DELTA= .325

SPHERES -.15904 TANGENT -.04035 SPACING .002

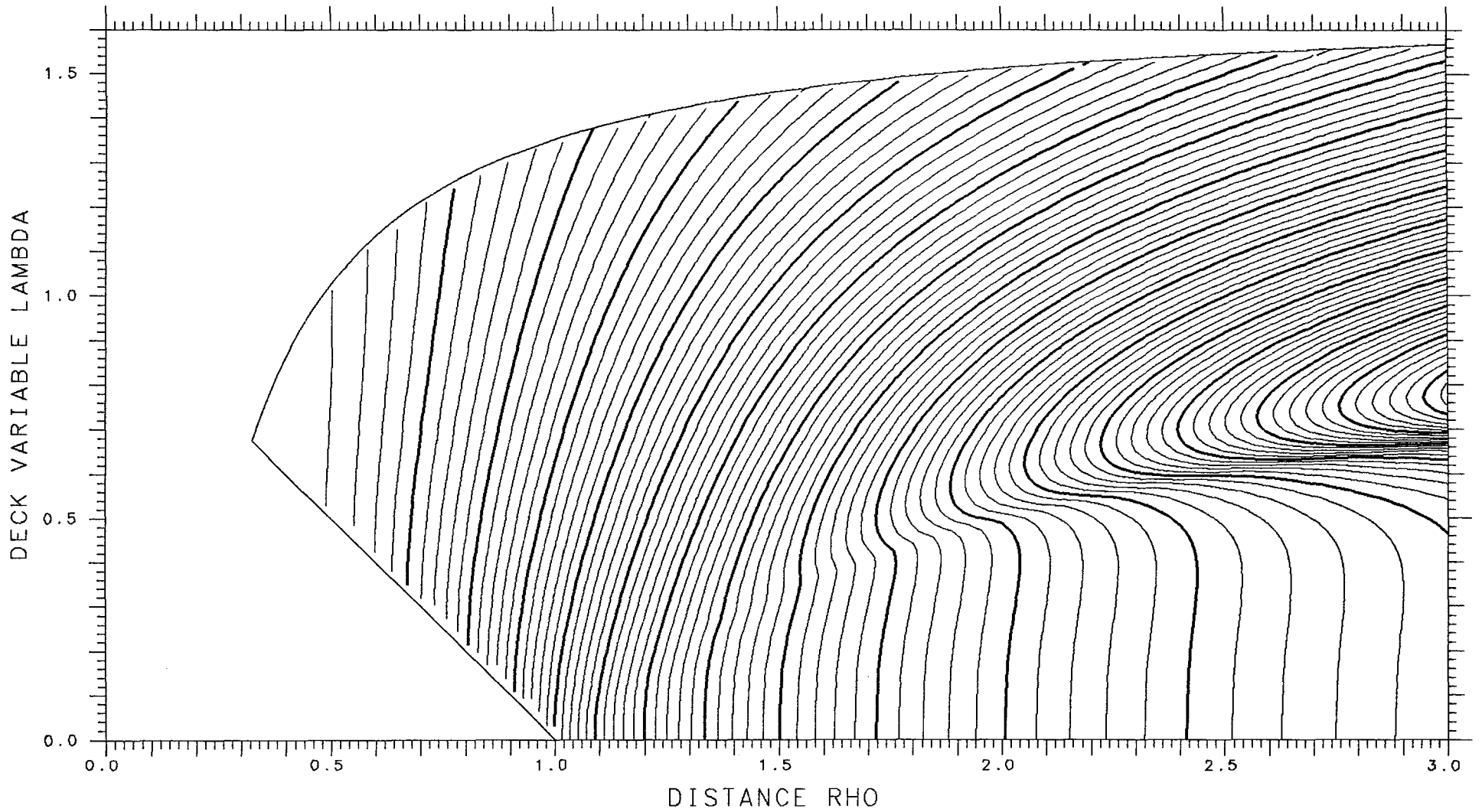

SURFACE ENERGY ASYMMETRY DELTA= .275

SPHERES .18251 TANGENT .18251 SPACING .005

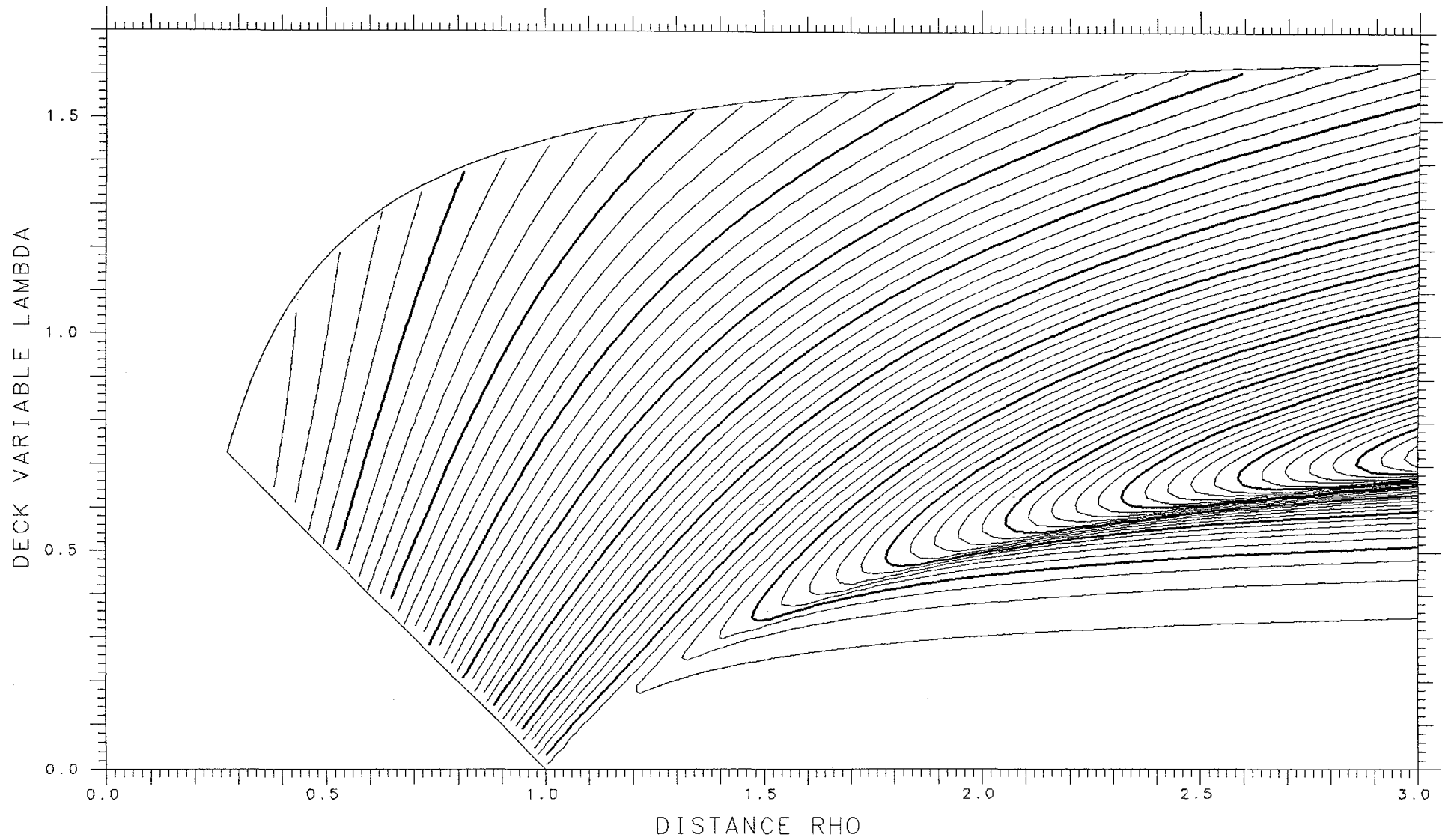

COULOMB ENERGY ASYMMETRY DELTA= .350

SPHERES -.13999 TANGENT -.03473 SPACING .002

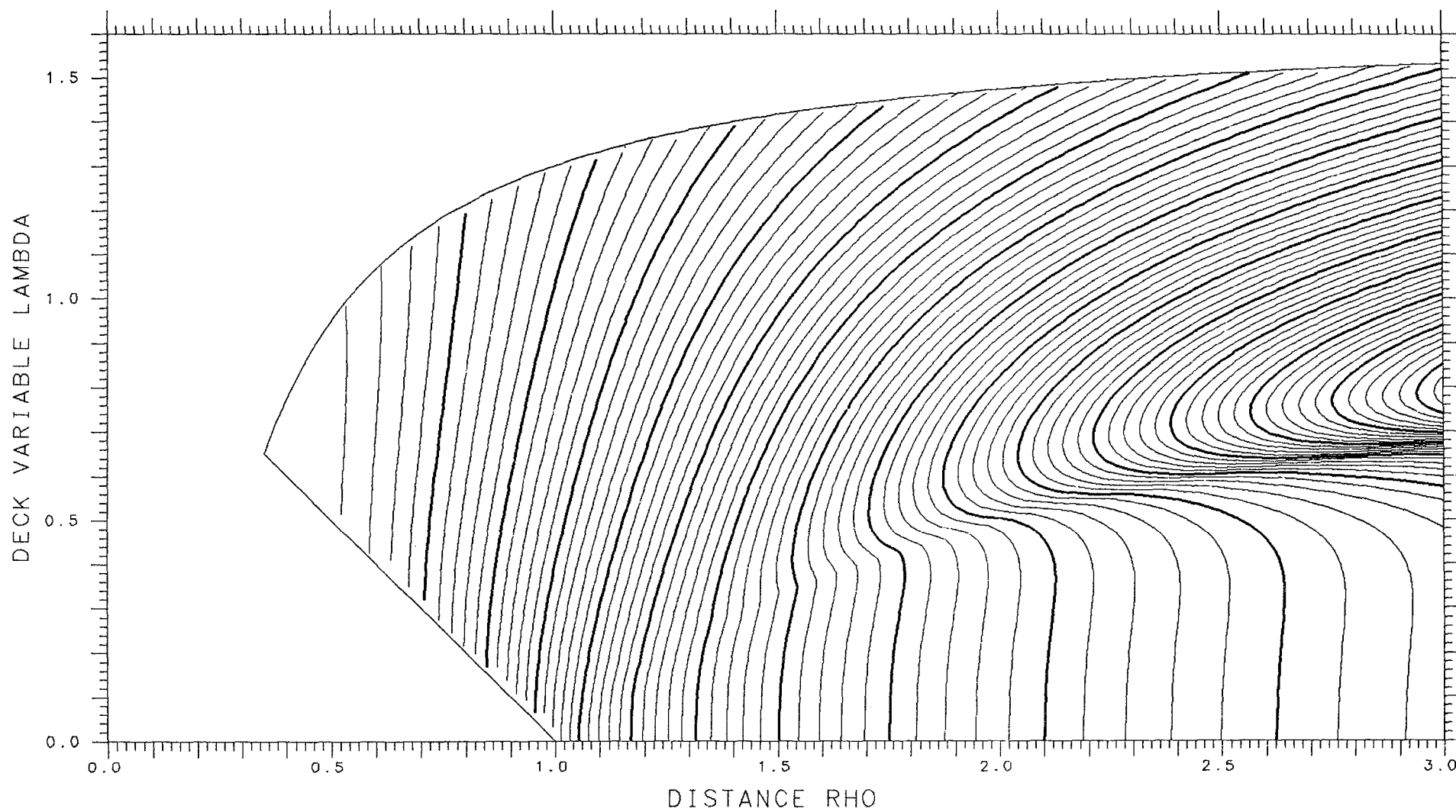

SURFACE ENERGY ASYMMETRY DELTA= .250

SPHERES .19376 TANGENT .19376 SPACING .005

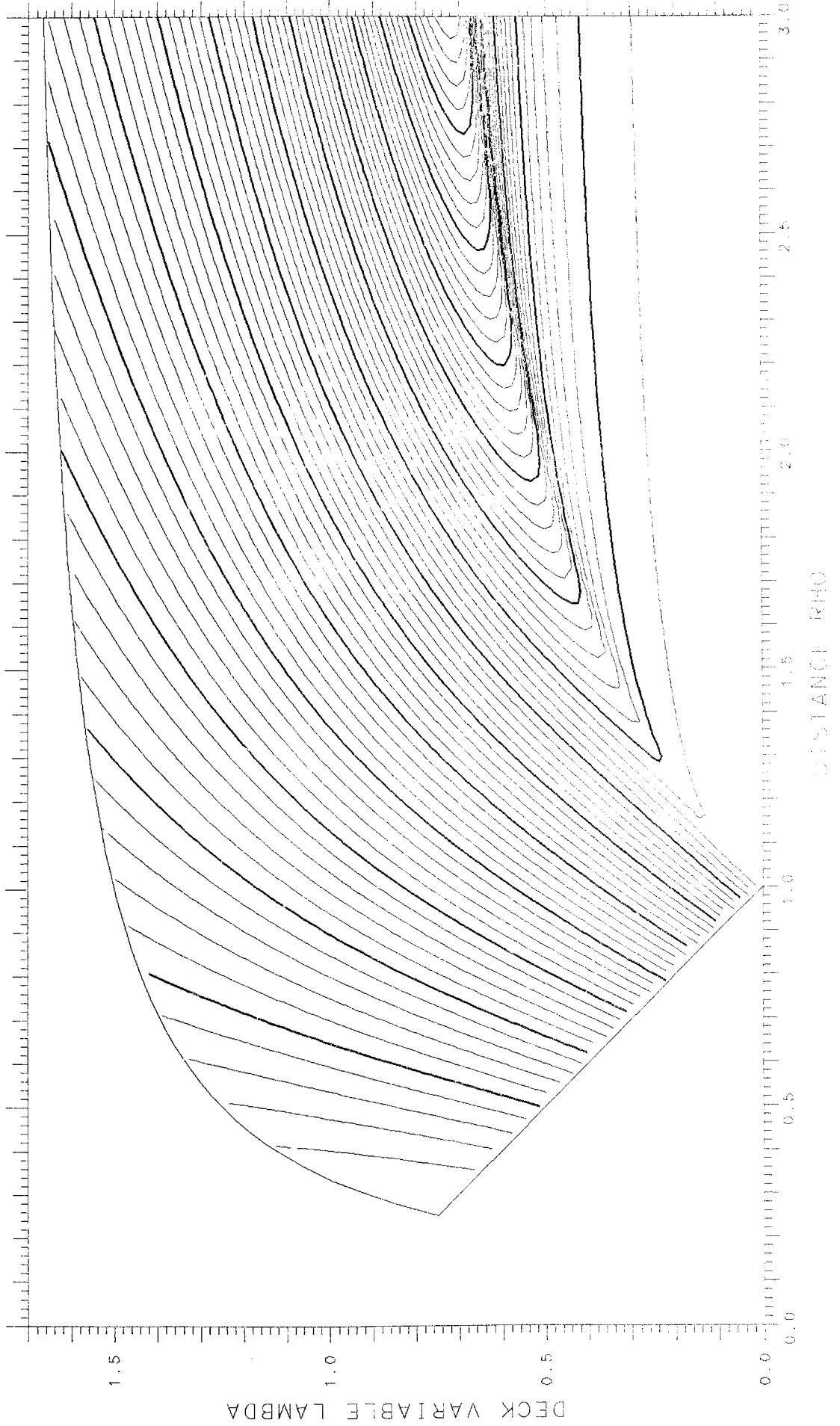

COULOMB ENERGY ASYMMETRY DELTA= .375

SPHERES -.12224 TANGENT -.02959 SPACING .002

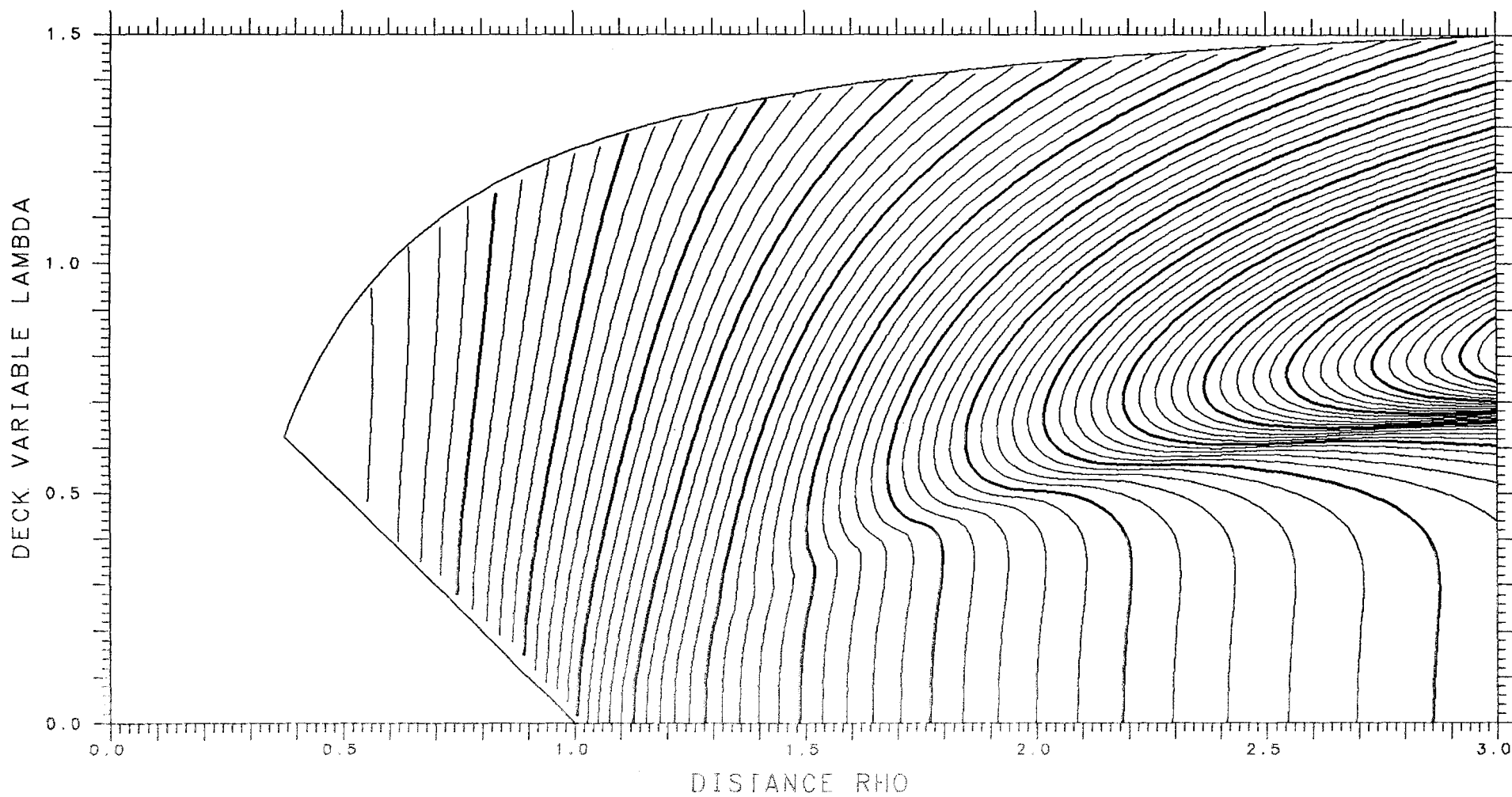

SURFACE ENERGY ASYMMETRY DELTA= .225

SPHERES .20463 TANGENT .20463 SPACING .005

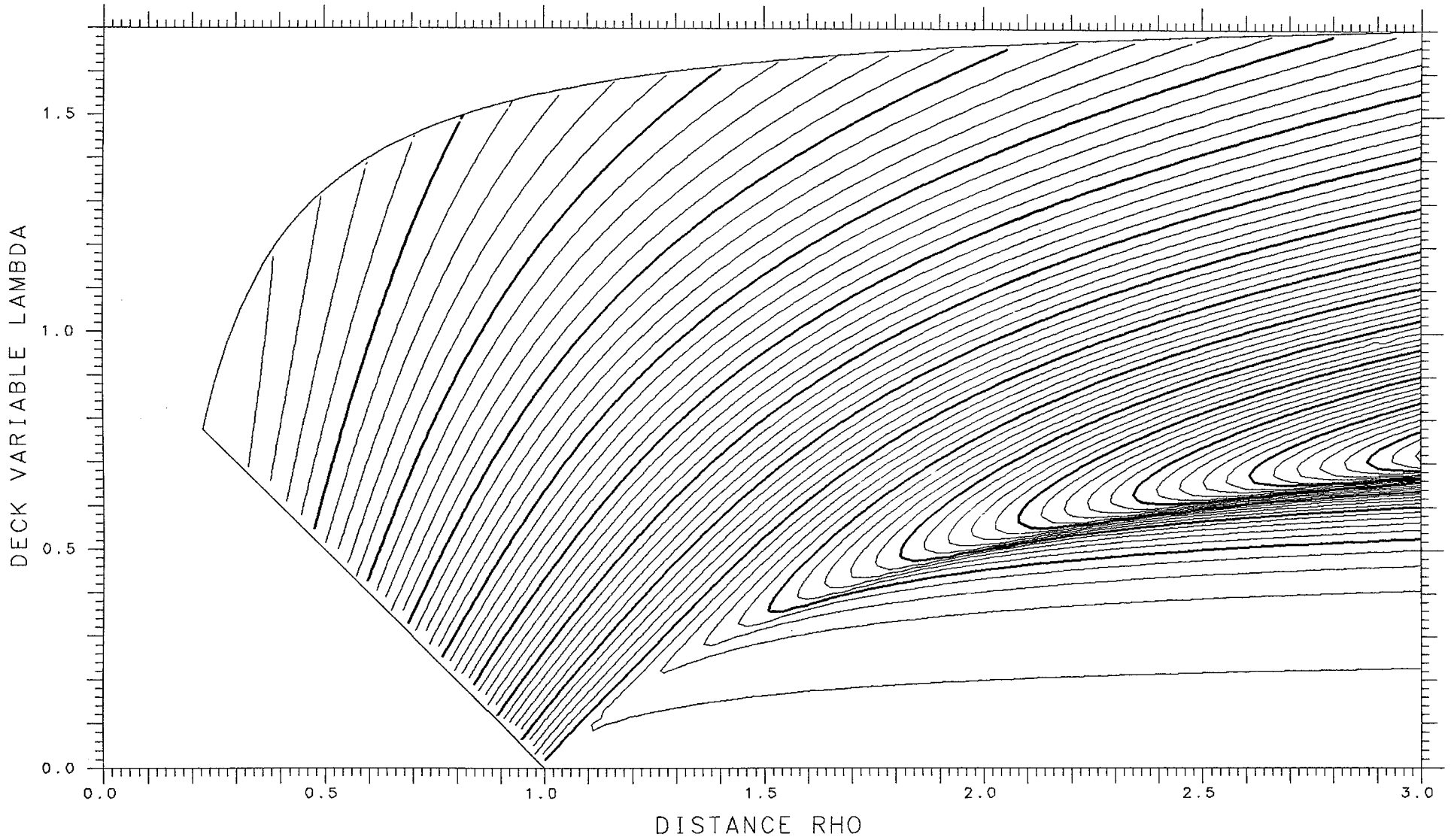

COULOMB ENERGY ASYMMETRY DELTA= .400

SPHERES -.10590 TANGENT -.02495 SPACING .002

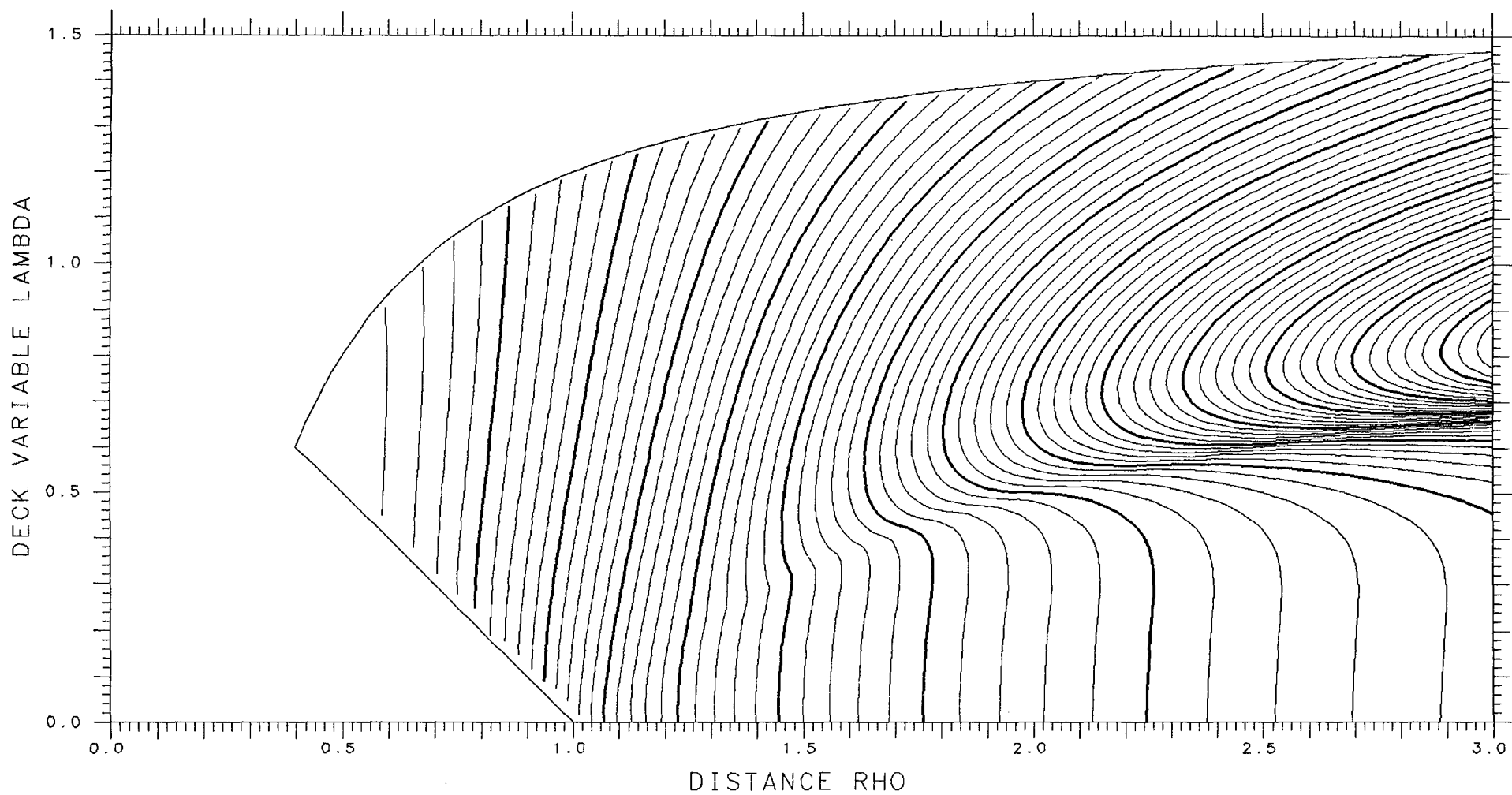

SURFACE ENERGY ASYMMETRY DELTA= .200

SPHERES .21497 TANGENT .21497 SPACING .005

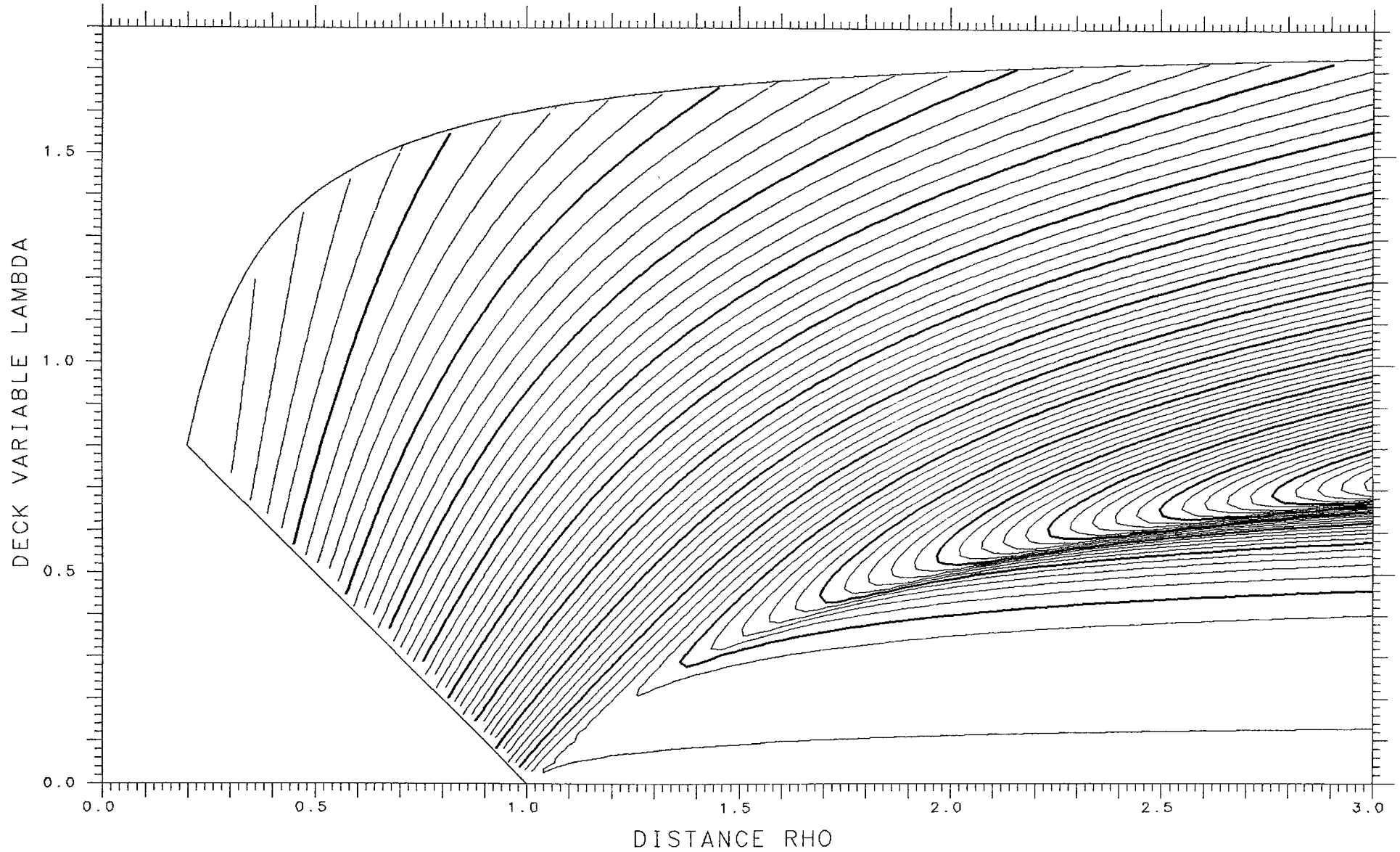

COULOMB ENERGY ASYMMETRY DELTA= .425

SPHERES -.09100 TANGENT -.02083 SPACING .002

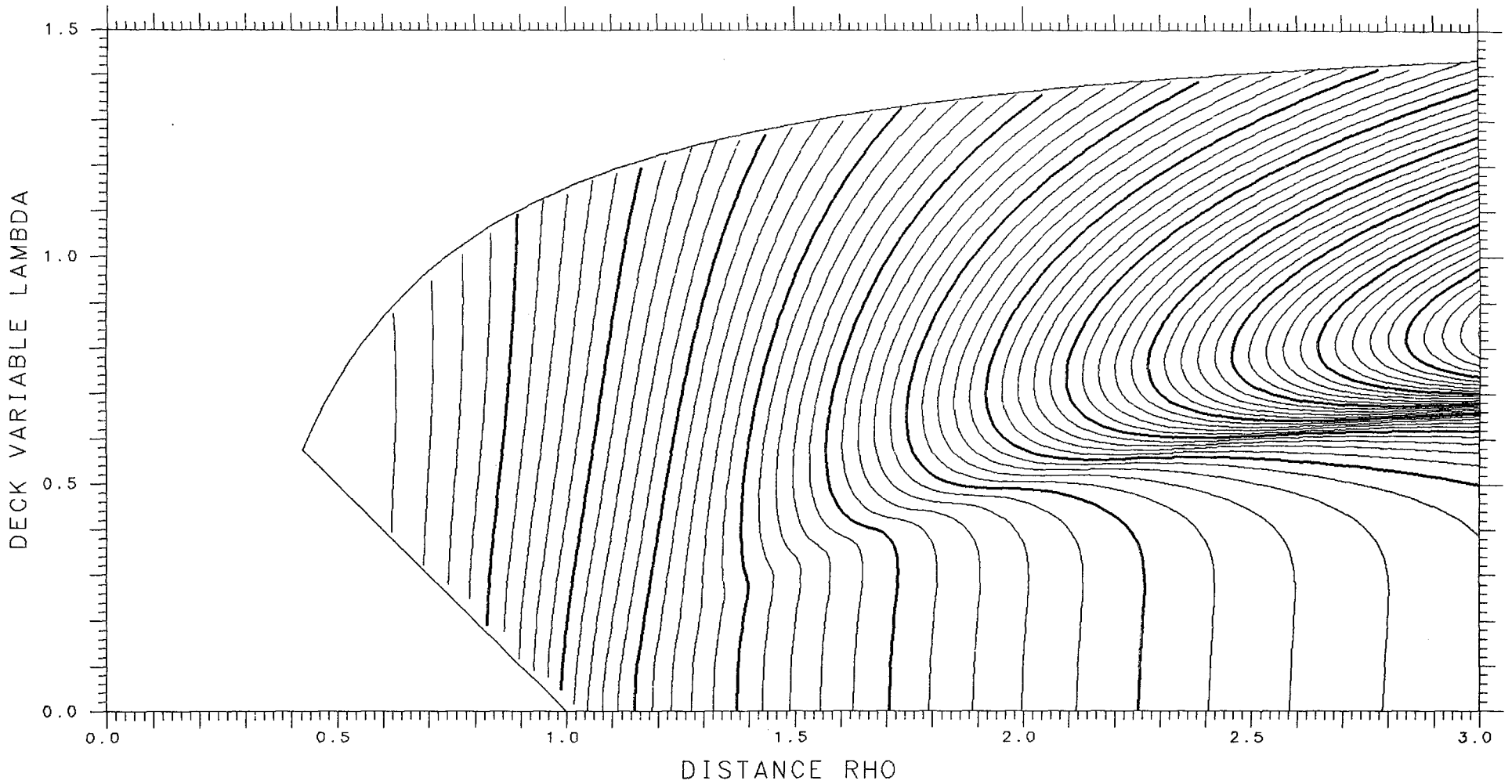

SURFACE ENERGY ASYMMETRY DELTA= .175

SPHERES .22460 TANGENT .22460 SPACING .005

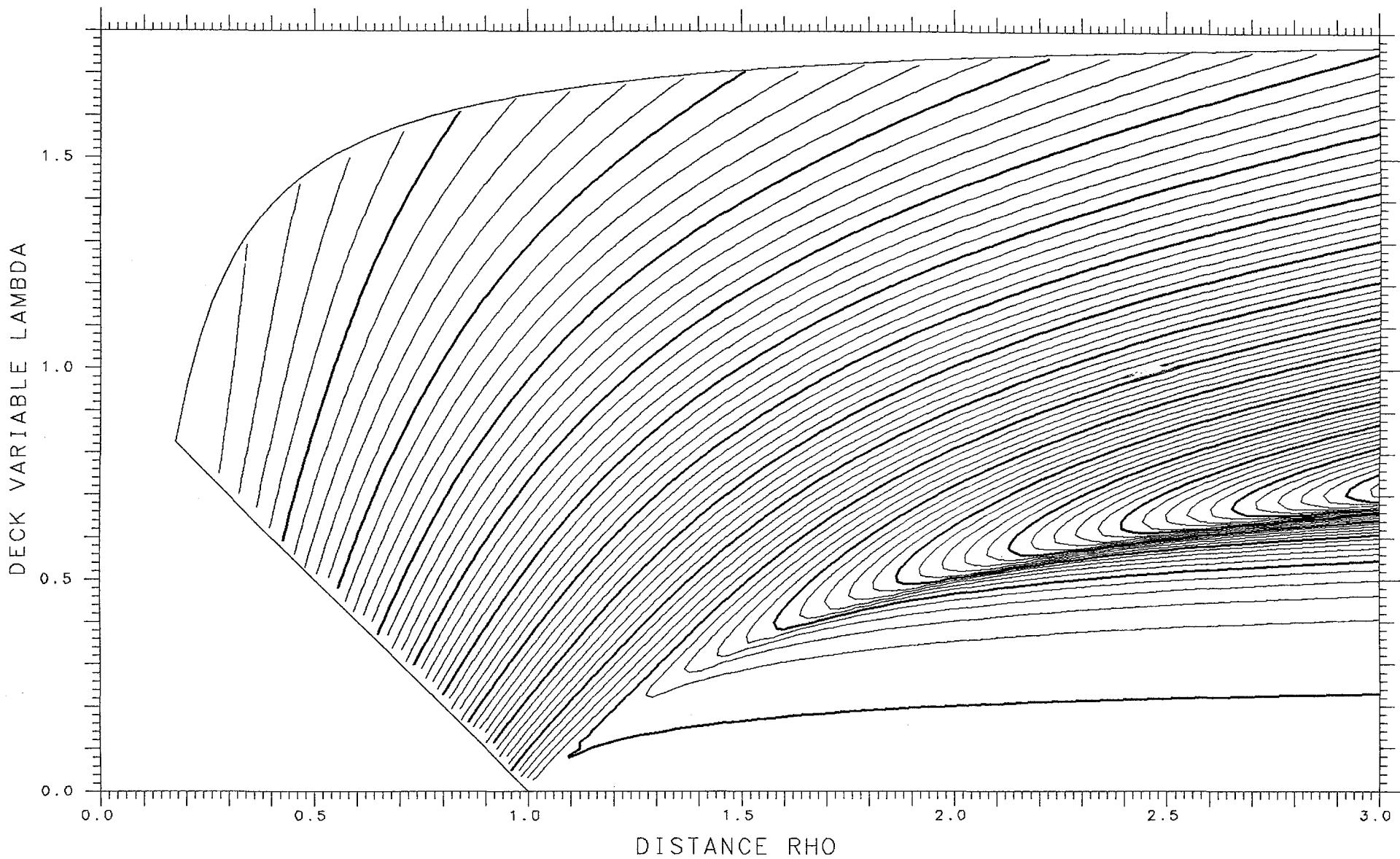

COULOMB ENERGY ASYMMETRY DELTA= .450

SPHERES -.07757 TANGENT -.01721 SPACING .002

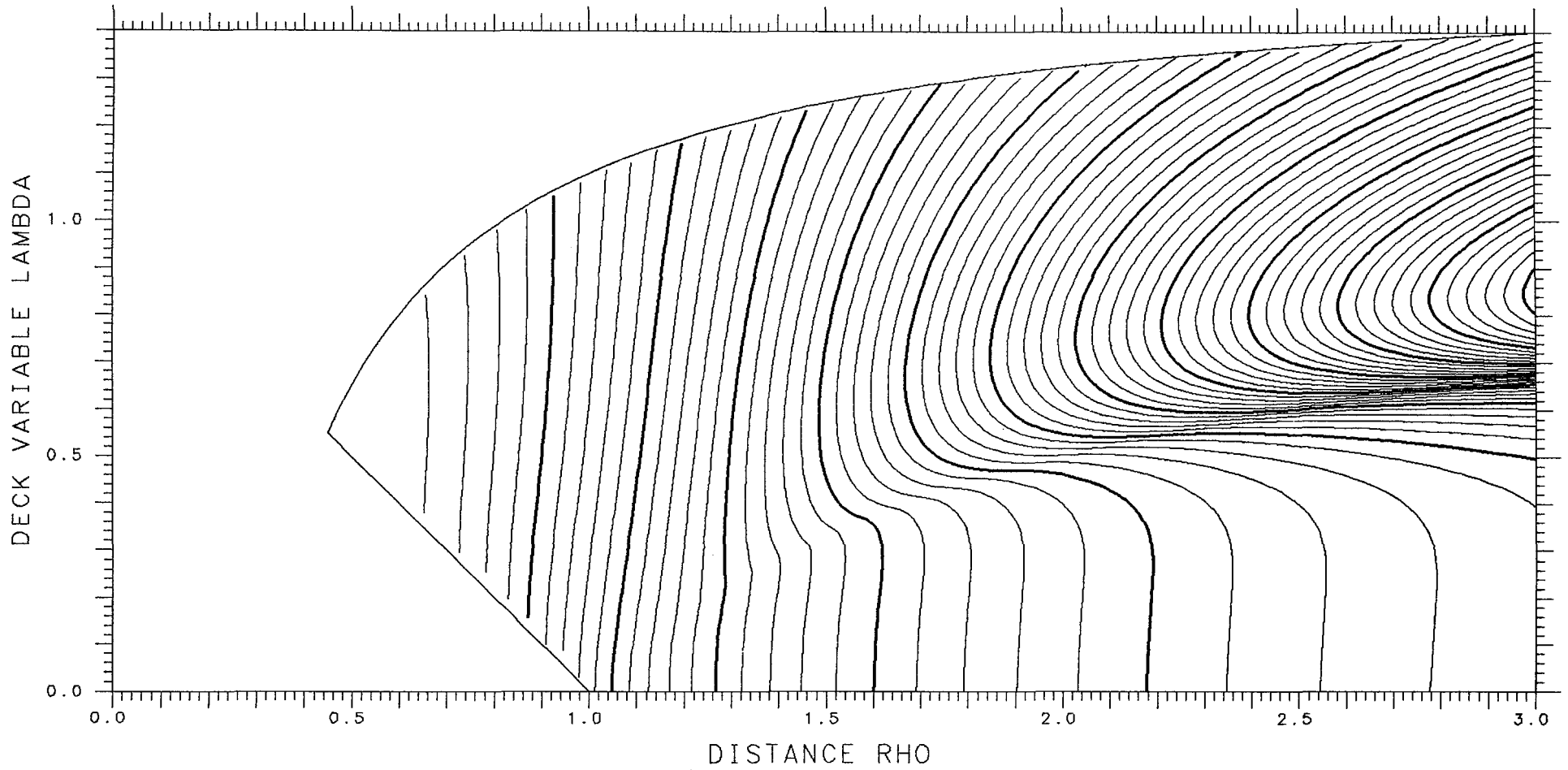

SURFACE ENERGY ASYMMETRY DELTA= .150

SPHERES .23337 TANGENT .23337 SPACING .005

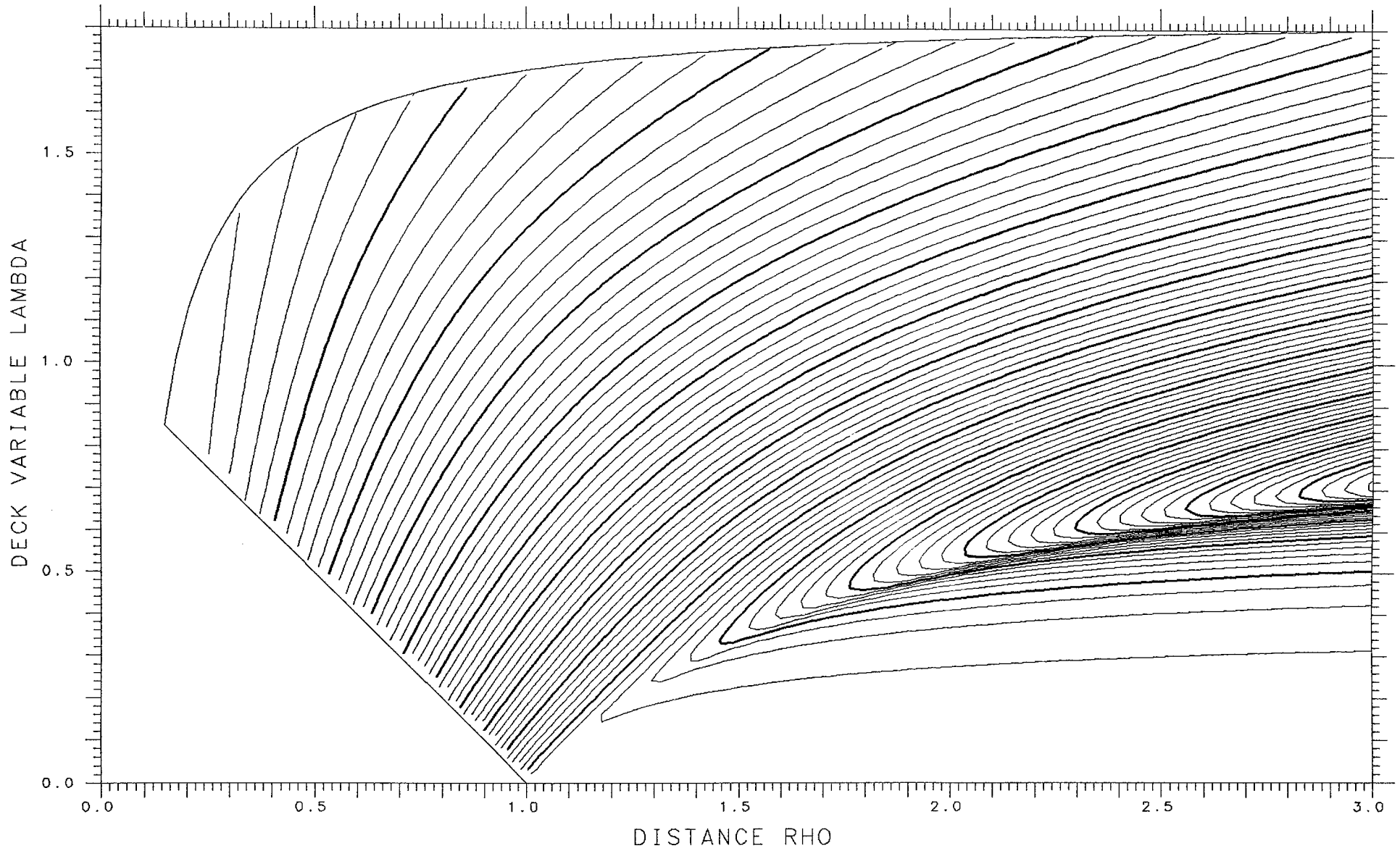

COULOMB ENERGY ASYMMETRY DELTA= .475

SPHERES -.06556 TANGENT -.01407 SPACING .002

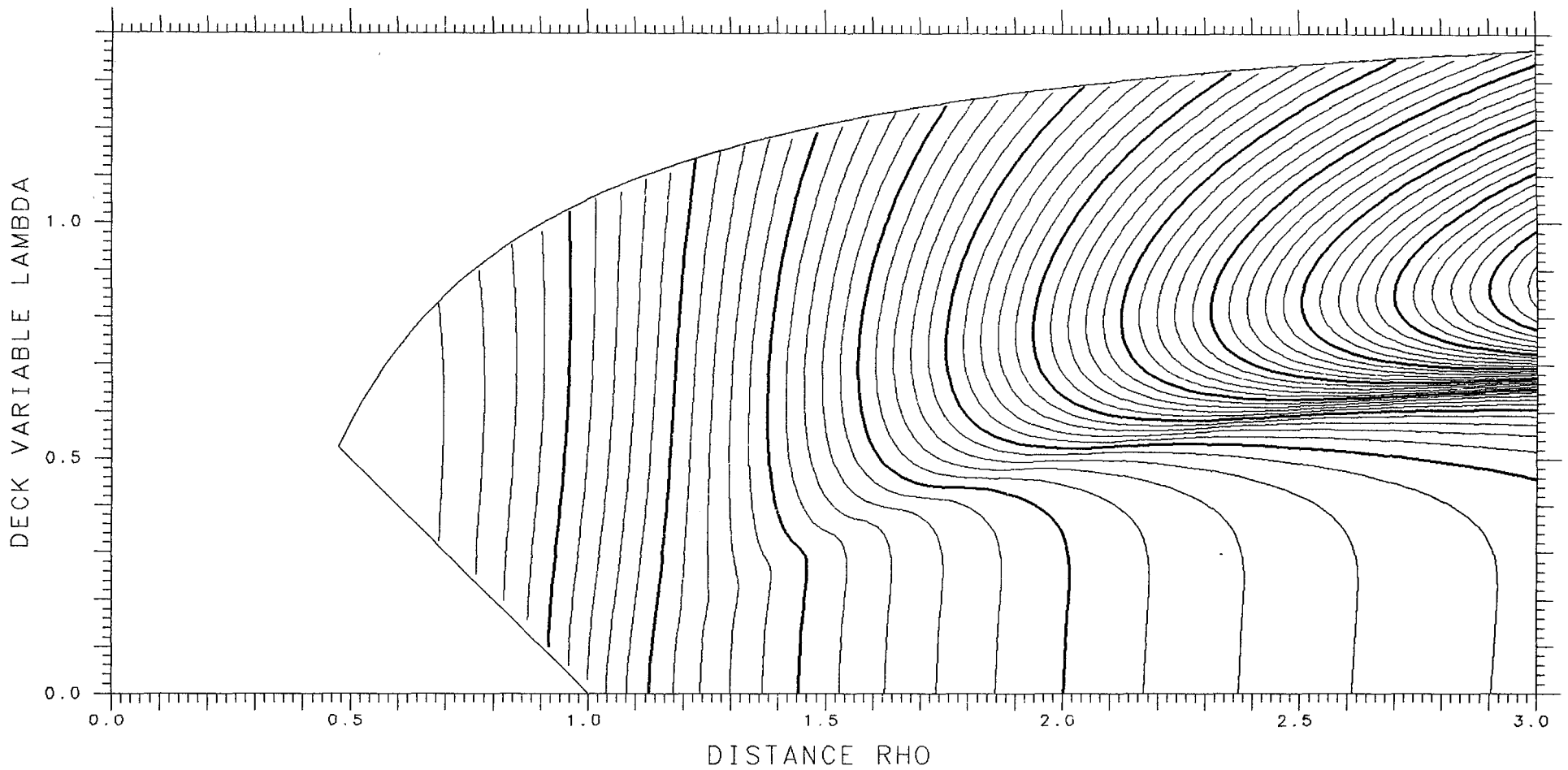

SURFACE ENERGY ASYMMETRY DELTA= .125

SPHERES .24112 TANGENT .24112 SPACING .005

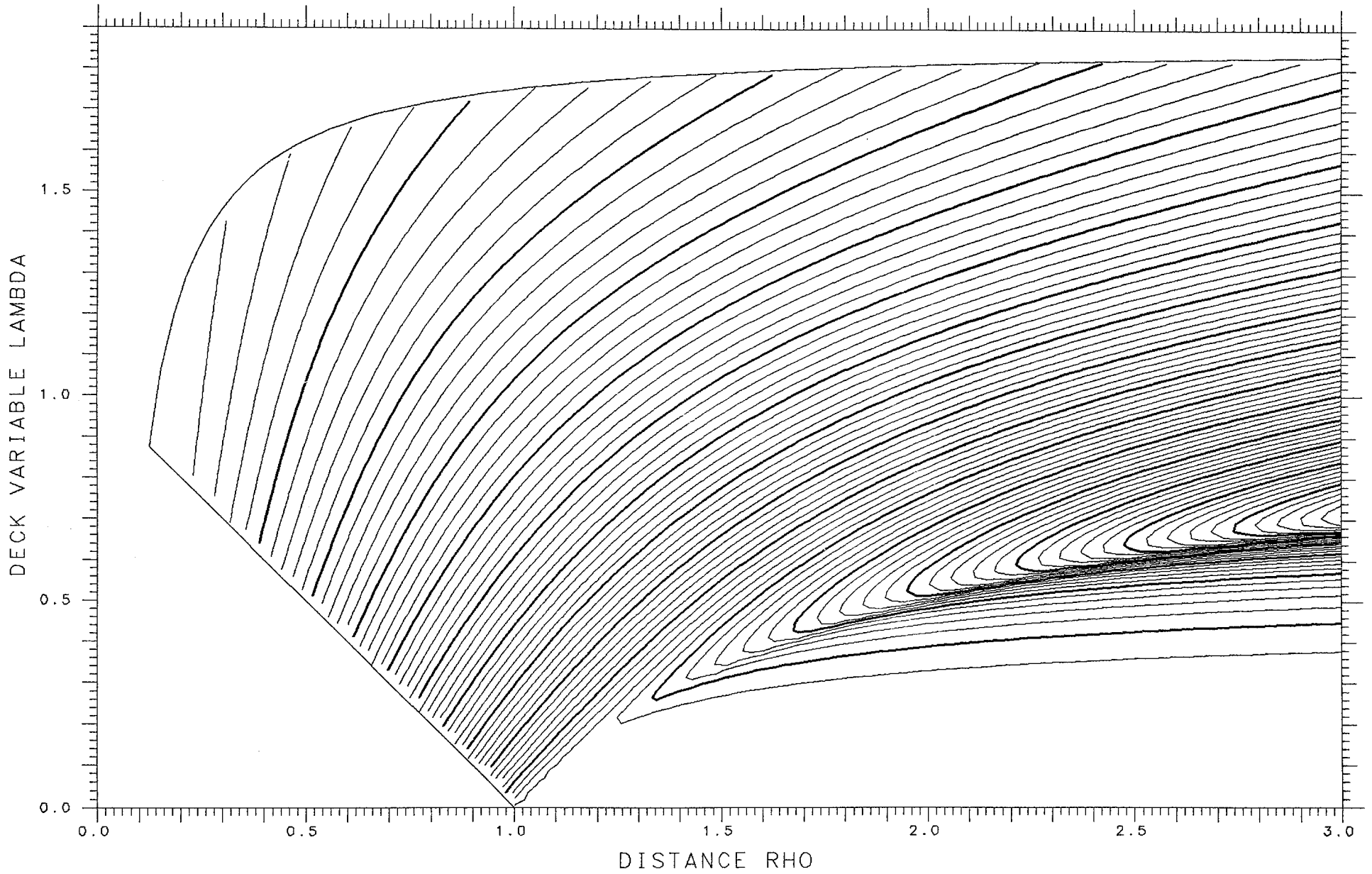

COULOMB ENERGY ASYMMETRY DELTA= .500

SPHERES -.05494 TANGENT -.01137 SPACING .002

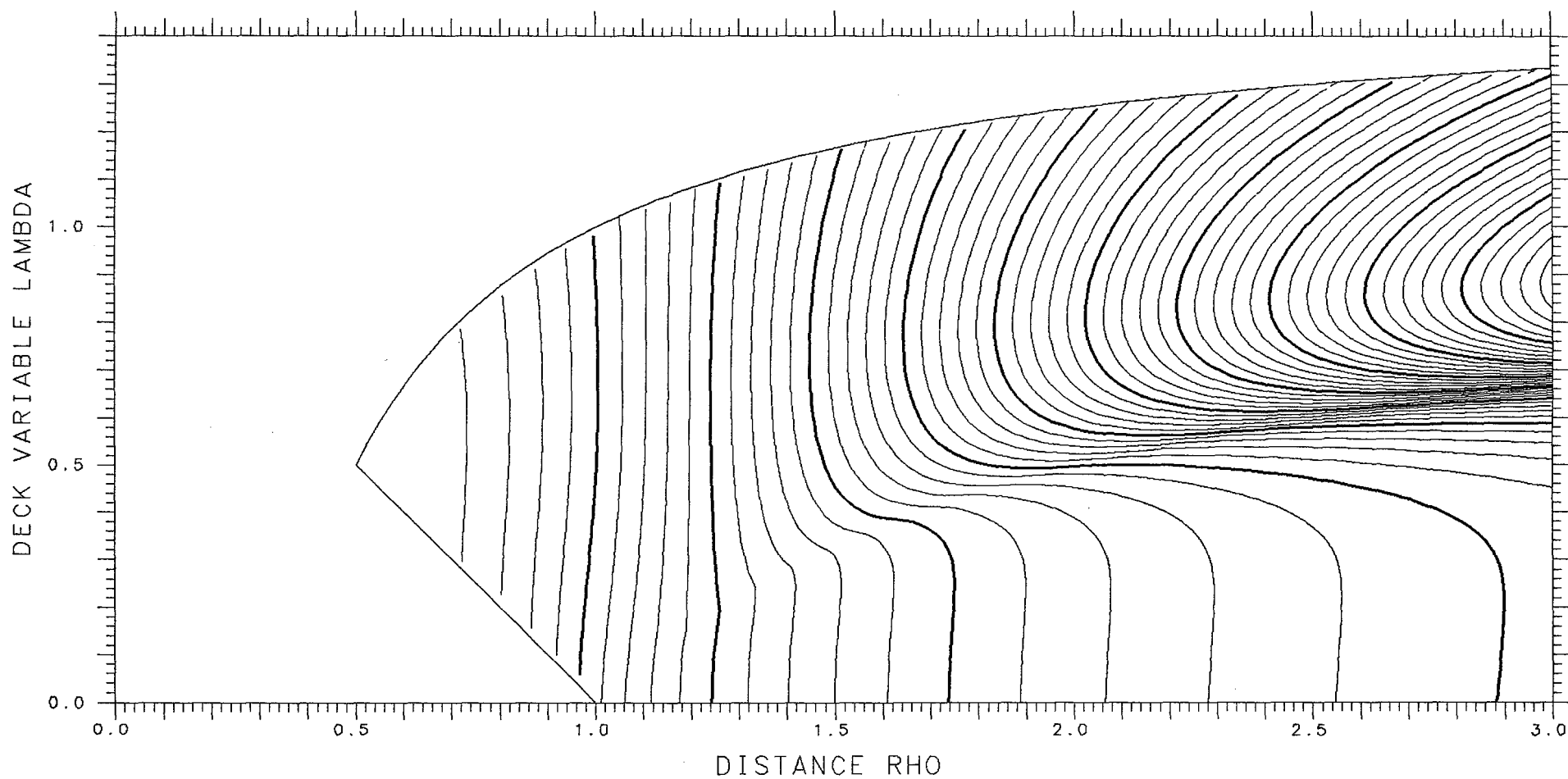

SURFACE ENERGY ASYMMETRY DELTA= .100

SPHERES .24769 TANGENT .24769 SPACING .005

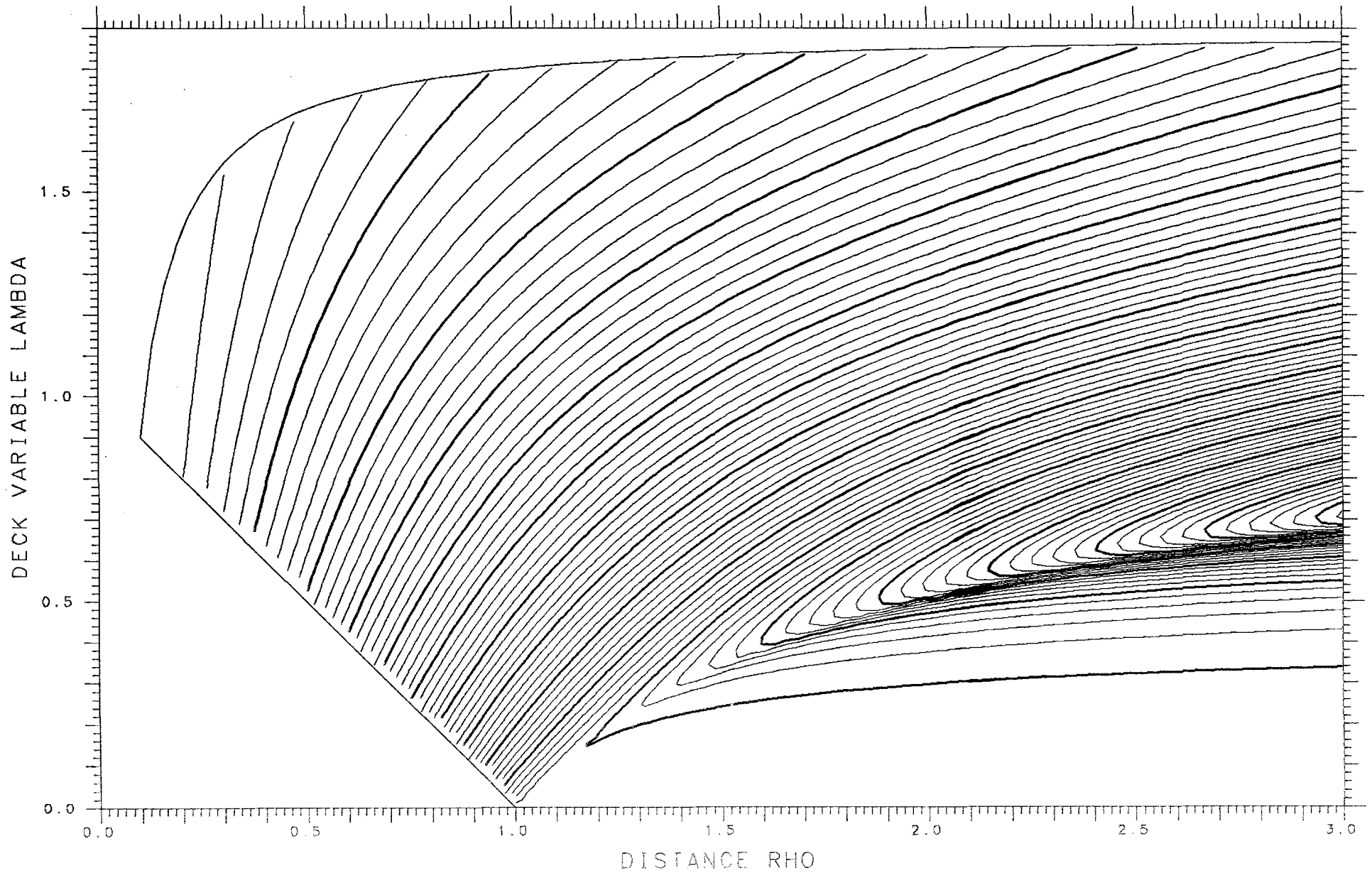

DECK VARIABLE LAMBDA

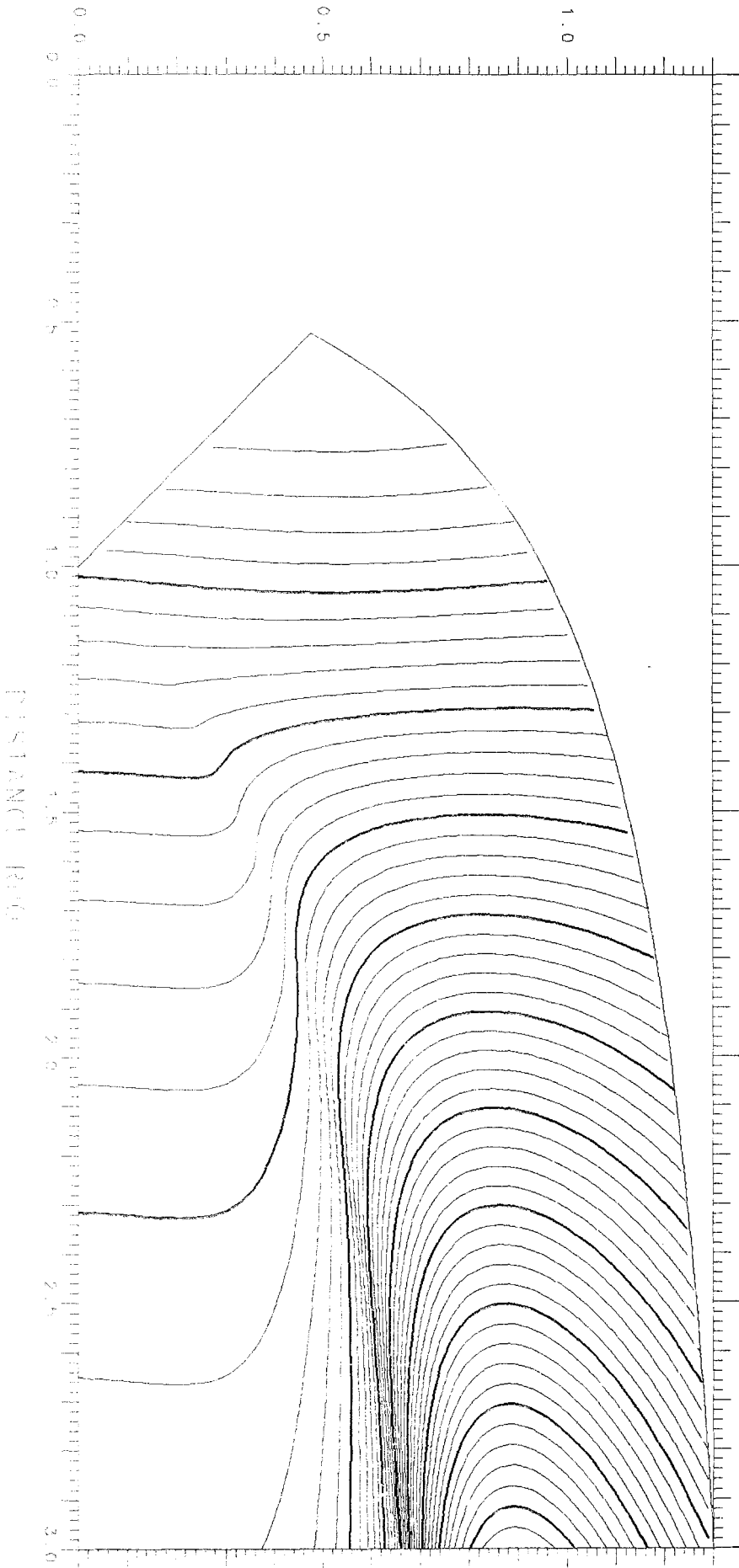

COULOMB ENERGY

ASYMMETRY DELTA = .525

SPHERES = .04562

TANGENT = .00907

SPACING .002

SURFACE ENERGY ASYMMETRY DELTA= .075

SPHERES .25295 TANGENT .25295 SPACING .005

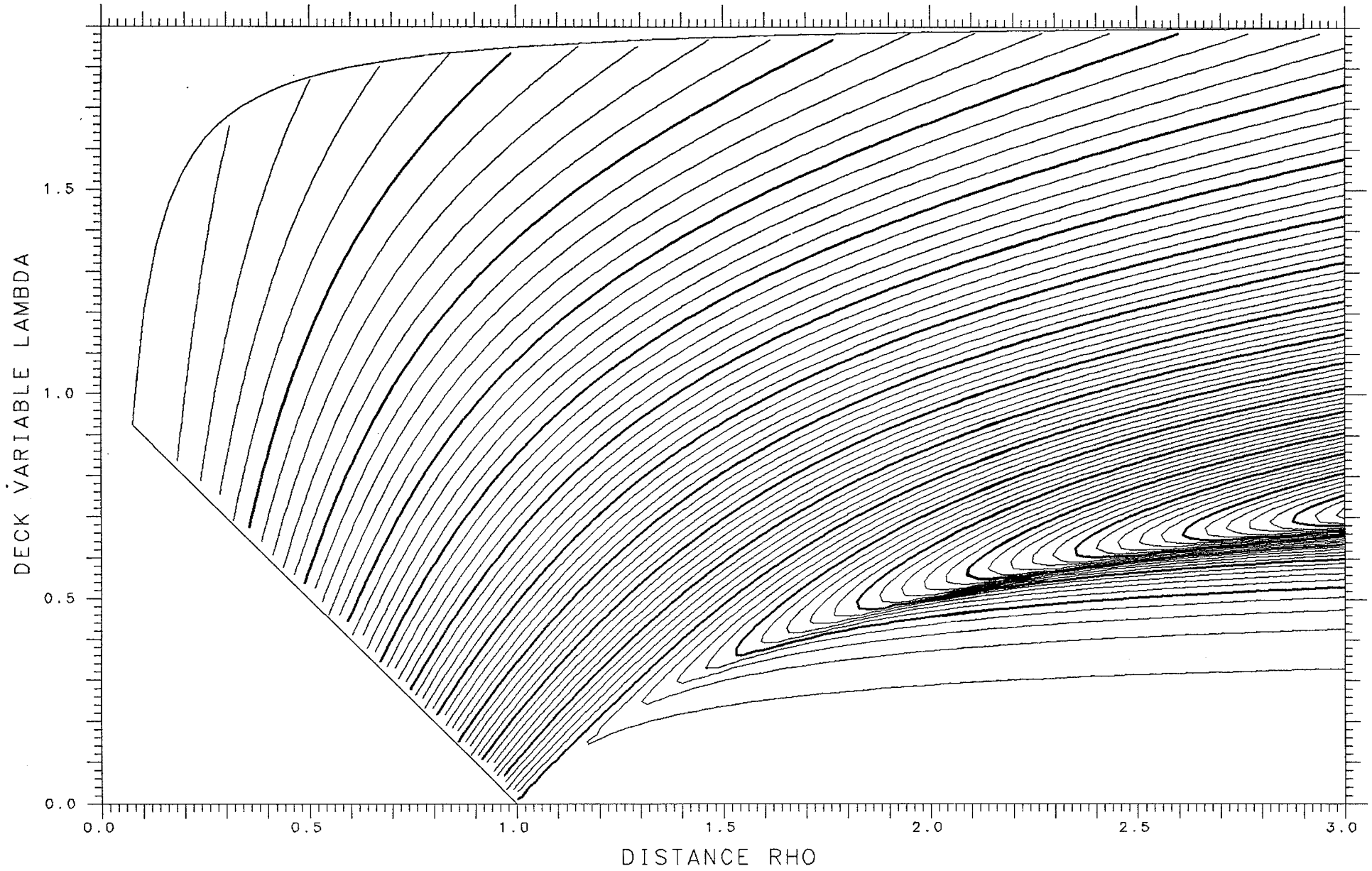

COULOMB ENERGY ASYMMETRY DELTA= .550

SPHERES -.03751 TANGENT -.00715 SPACING .002

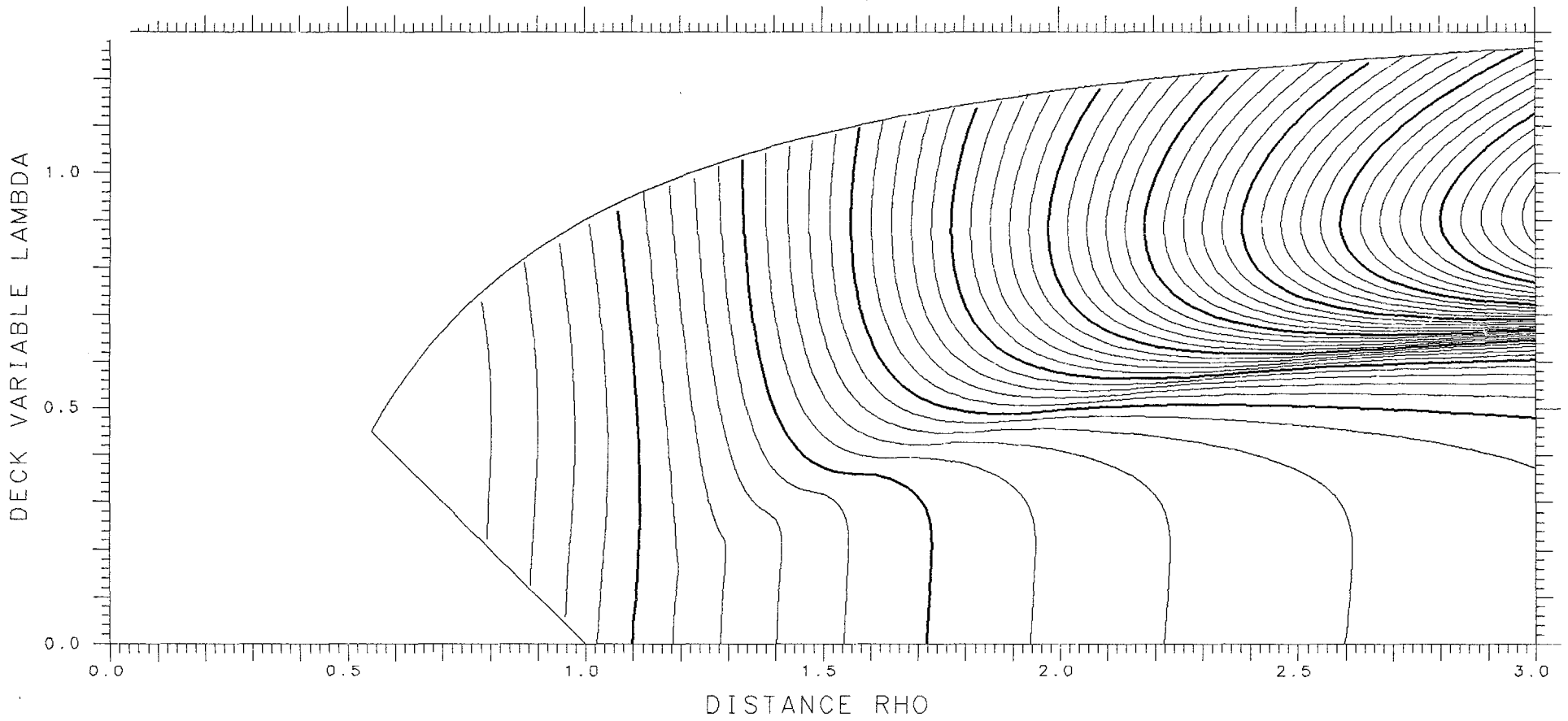

SURFACE ENERGY ASYMMETRY DELTA= .050

SPHERES .25679 TANGENT .25679 SPACING .005

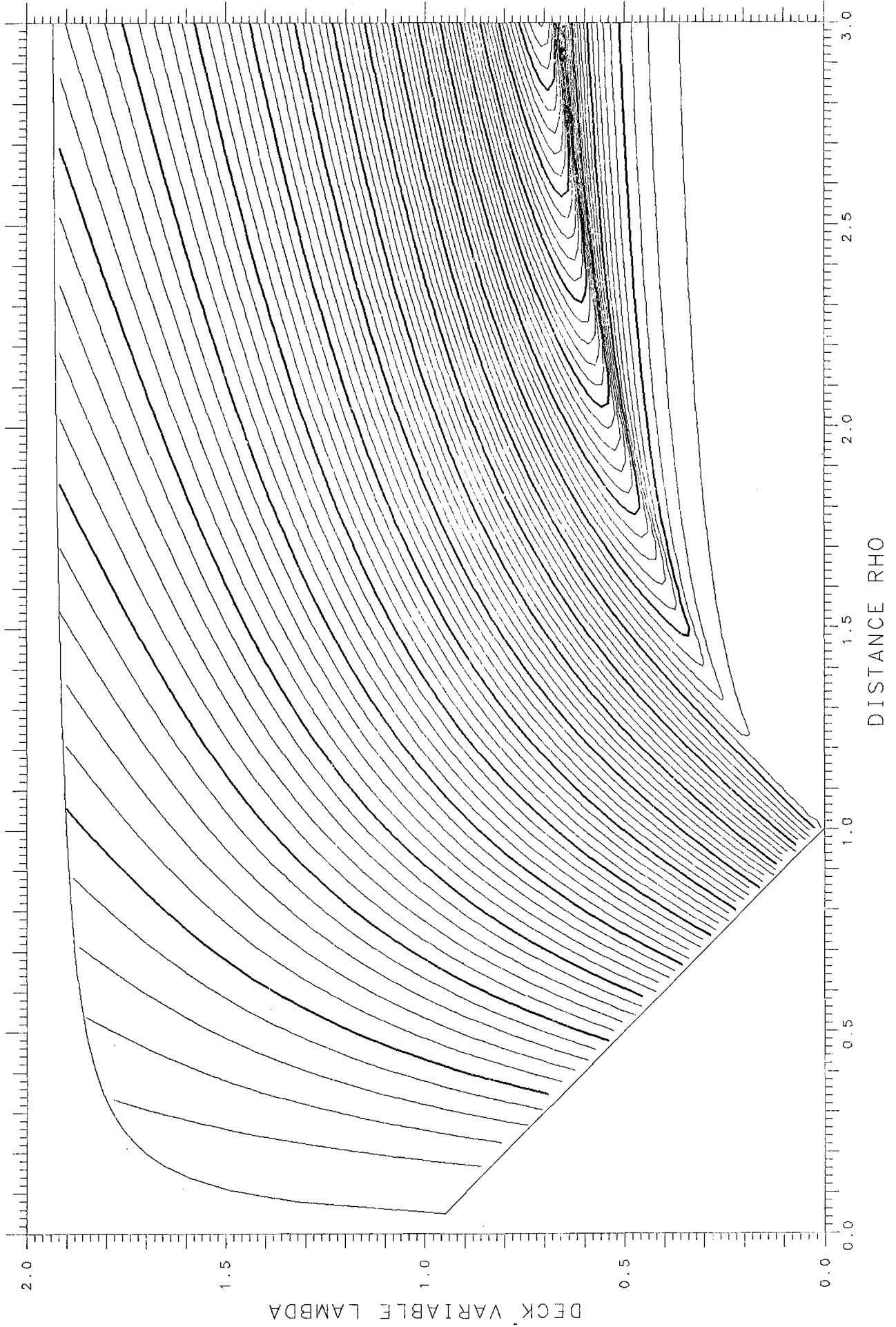

COULOMB ENERGY ASYMMETRY DELTA= .575
SPHERES -.03052 TANGENT -.00556 SPACING .002

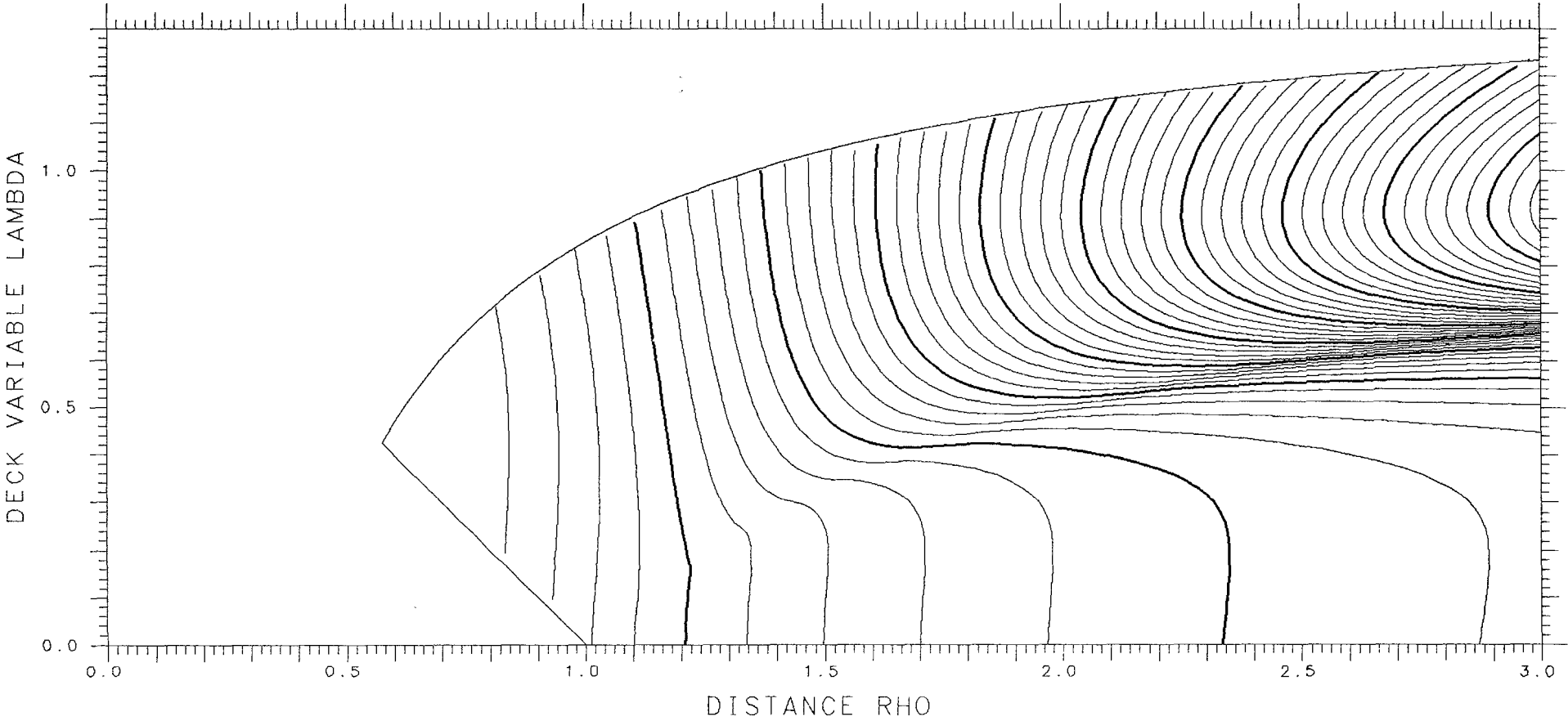

SURFACE ENERGY ASYMMETRY_DELTA= .025

SPHERES .25914 TANGENT .25914 SPACING .005

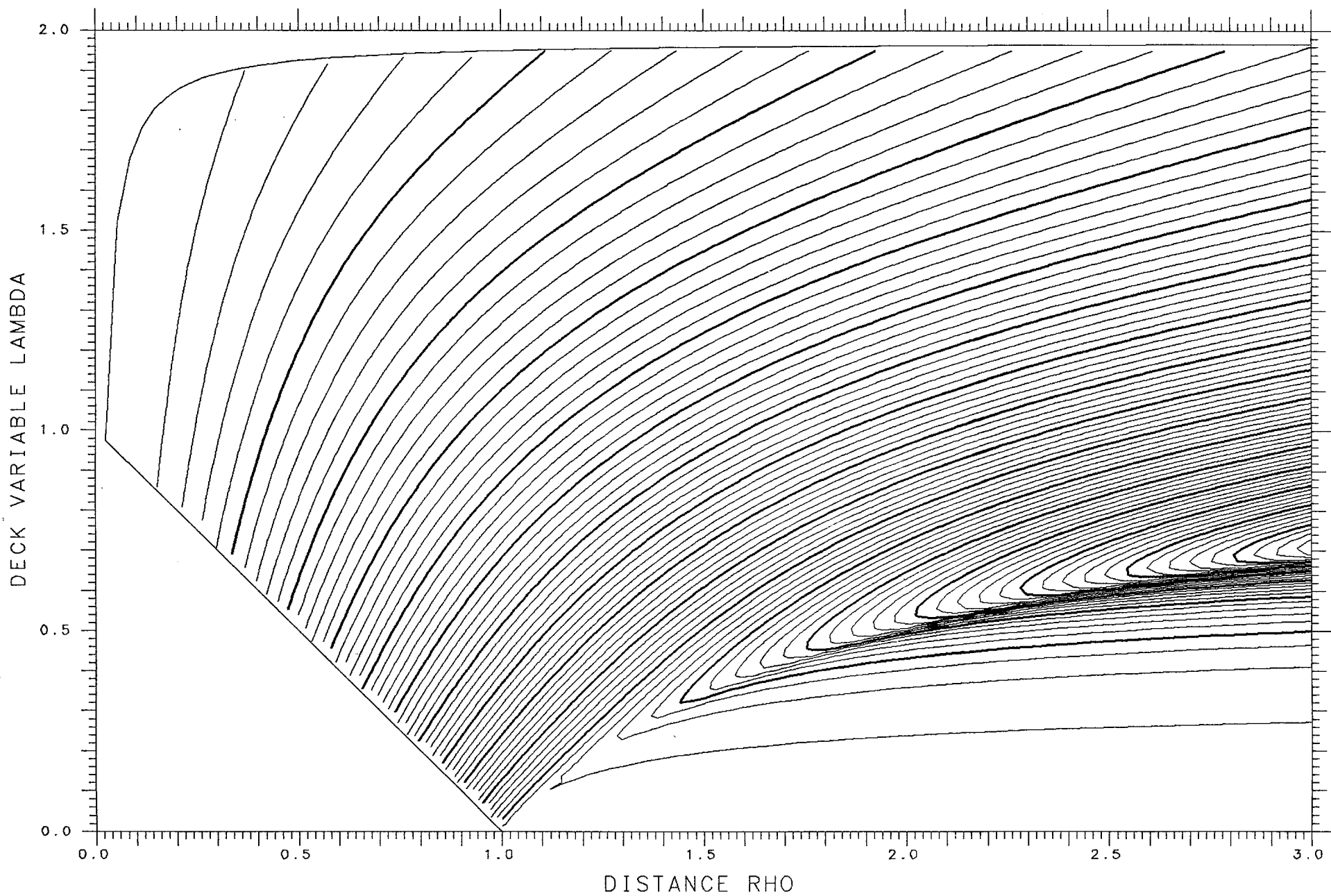

COULOMB ENERGY ASYMMETRY DELTA= .600

SPHERES -.02456 TANGENT -.00426 SPACING .002

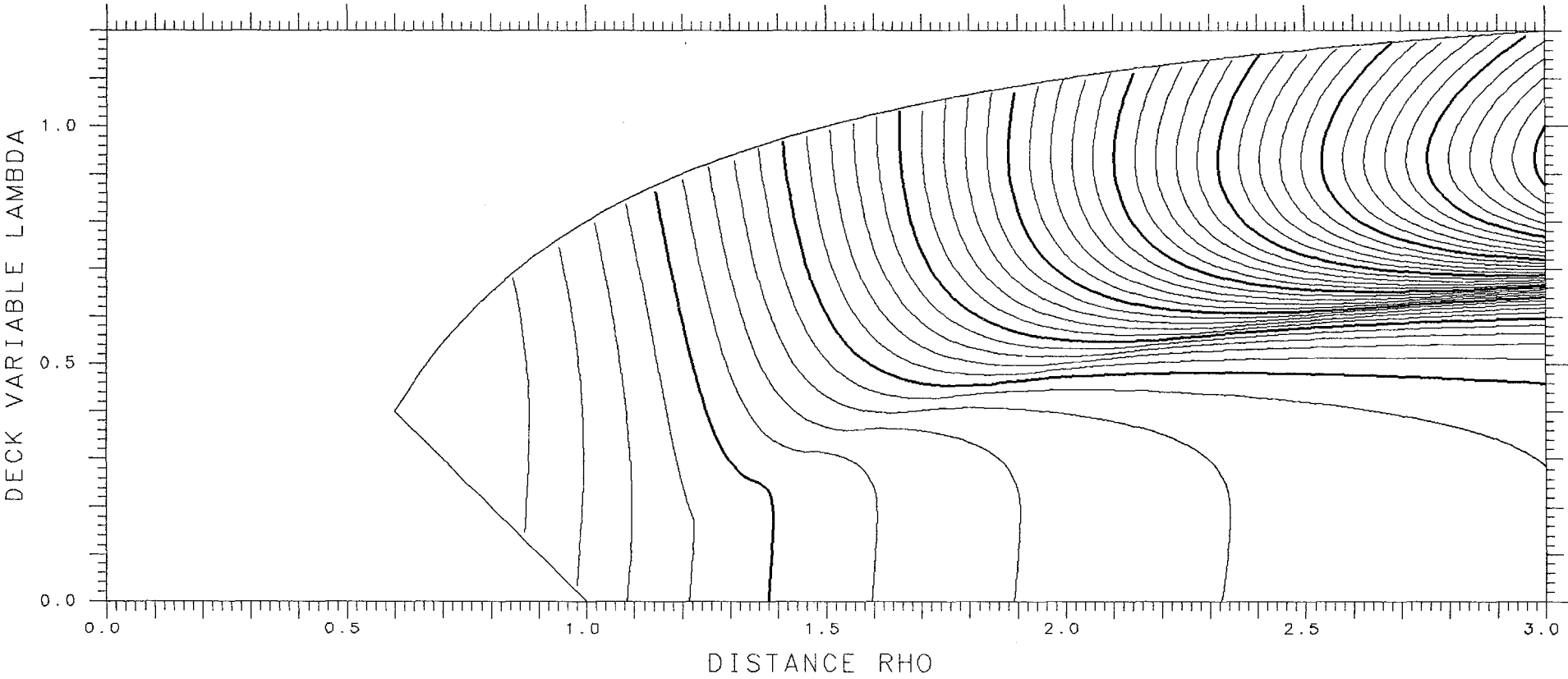

SURFACE ENERGY ASYMMETRY DELTA=0.

SPHERES .25992 TANGENT .25992 SPACING .005

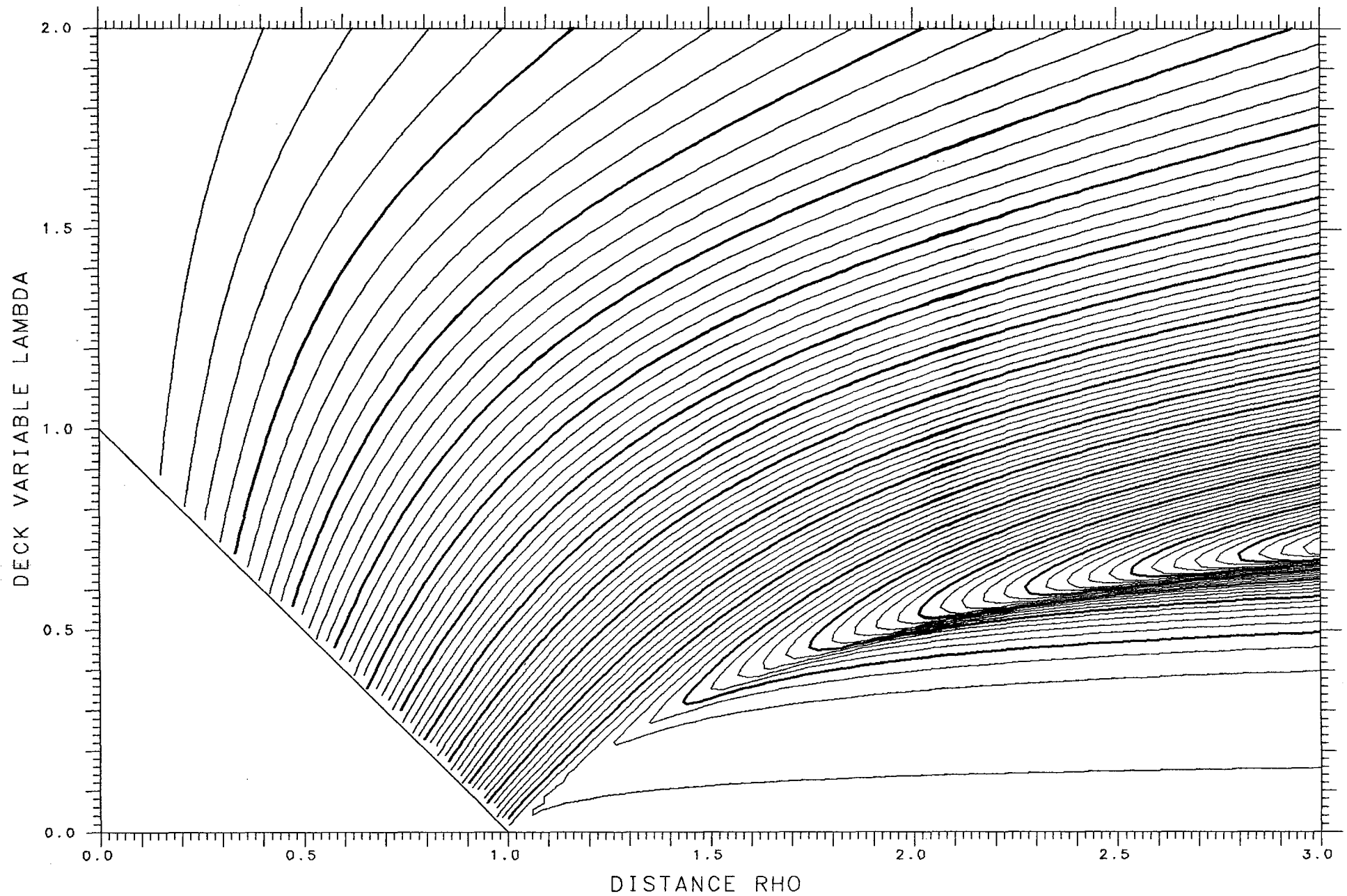

X= .050

ASYMMETRY DELTA=0.

FRACTIONAL= .5000

SPHERES .22292

TANGENT .24917

LENGTH 4.270

ENERGY 86.48

SPACING .005

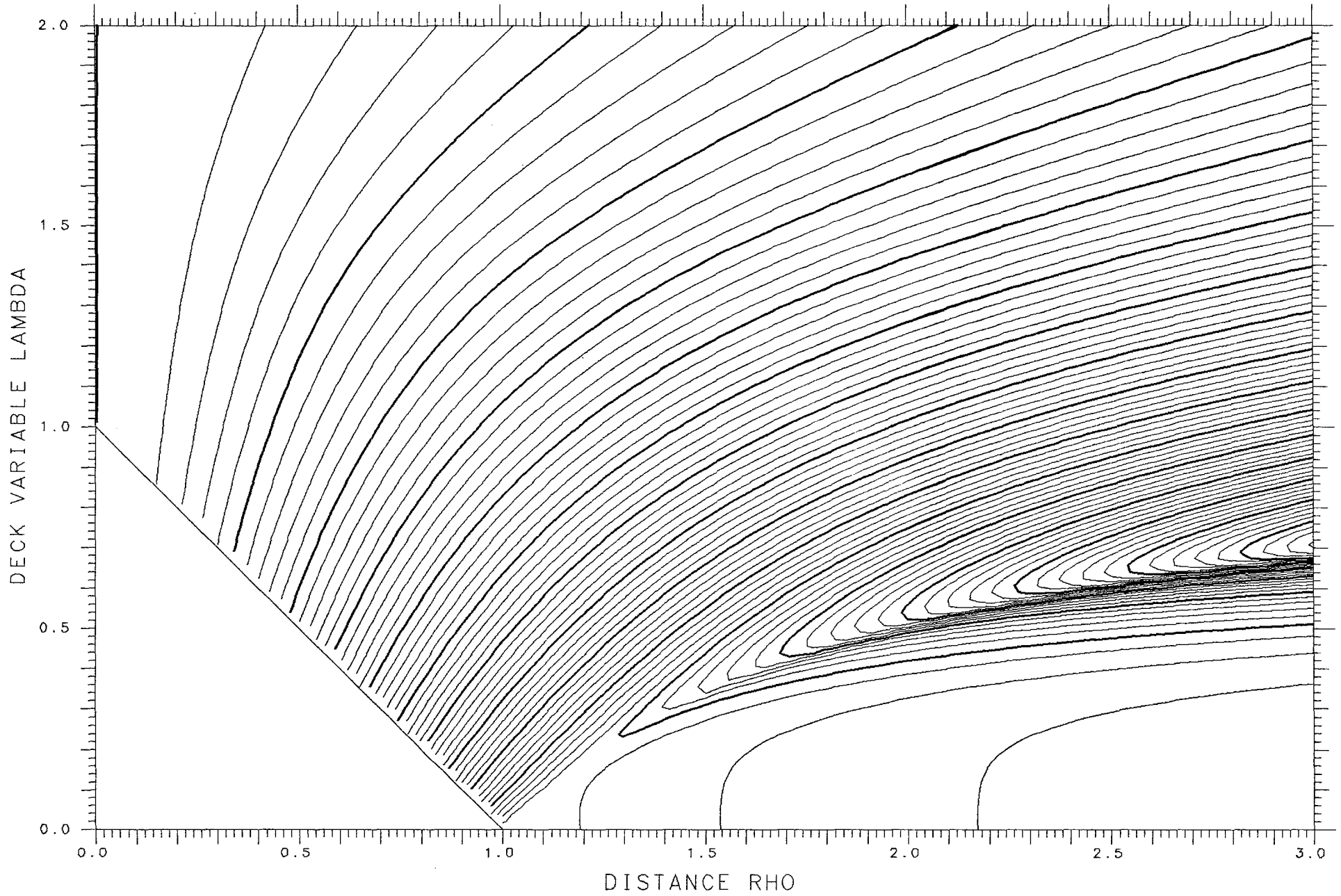

X=1.500 ASYMMETRY DELTA= .050 FRACTIONAL= .5745
SPHERES -.82999 TANGENT -.05811 LENGTH 15.528 ENERGY 980.15 SPACING .005

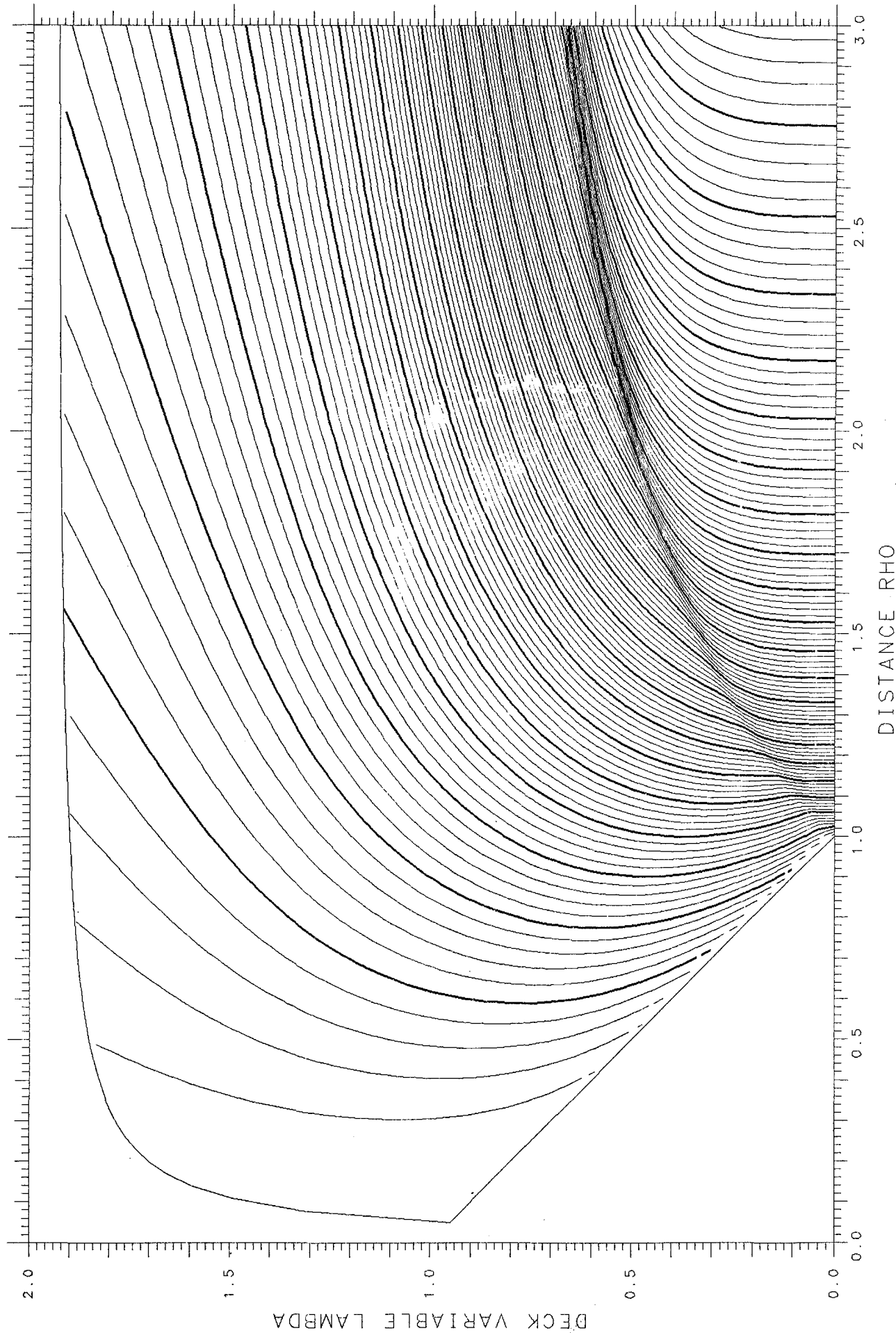

X= .050 ASYMMETRY DELTA= .025 FRACTIONAL= .5374

SPHERES .22233 TANGENT .24844 LENGTH 4.268 ENERGY 86.48 SPACING .005

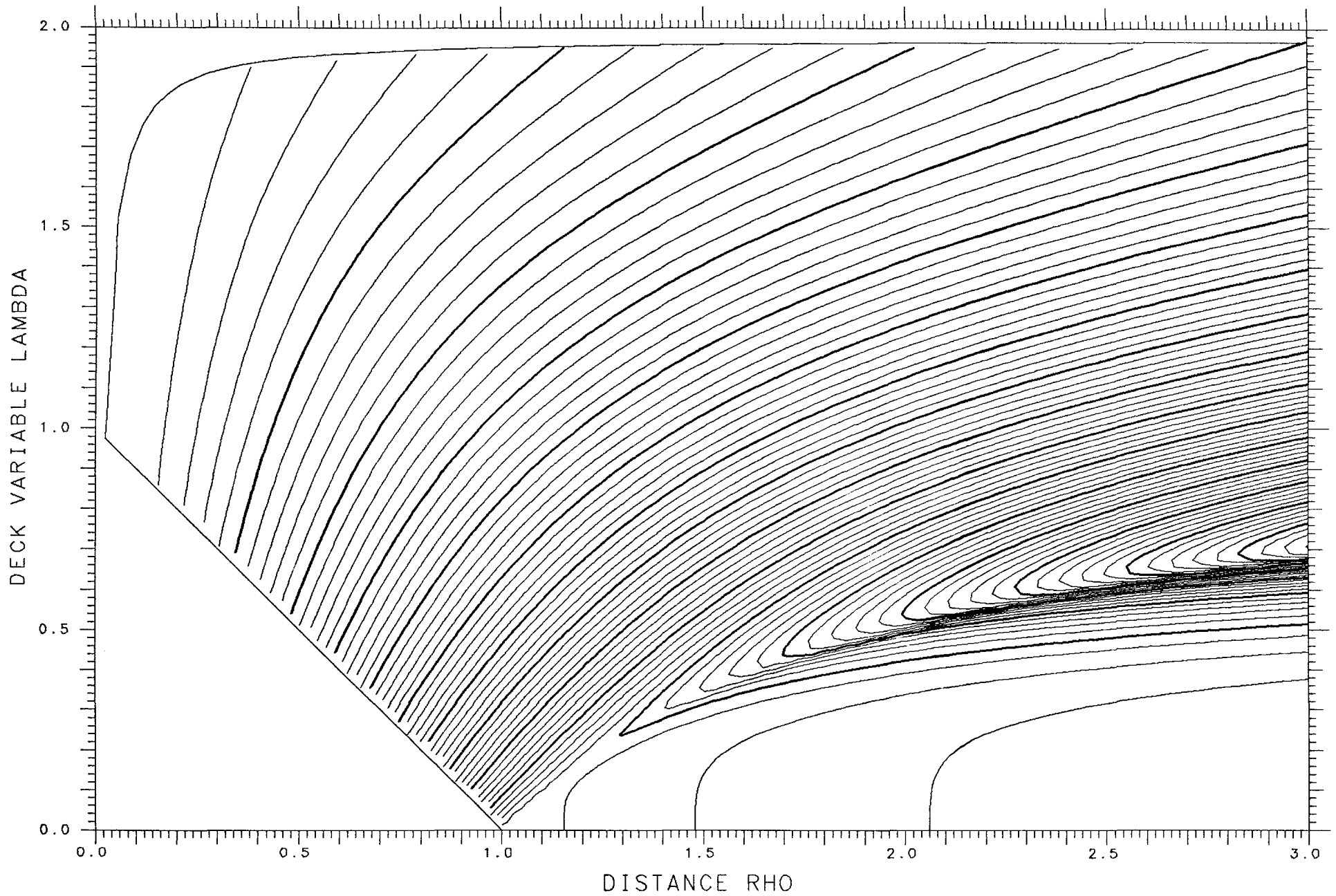

X=1.500

ASYMMETRY DELTA= .025

FRACTIONAL= .5374

SPHERES -.84510

TANGENT -.06157

LENGTH 15.557

ENERGY 980.15

SPACING .005

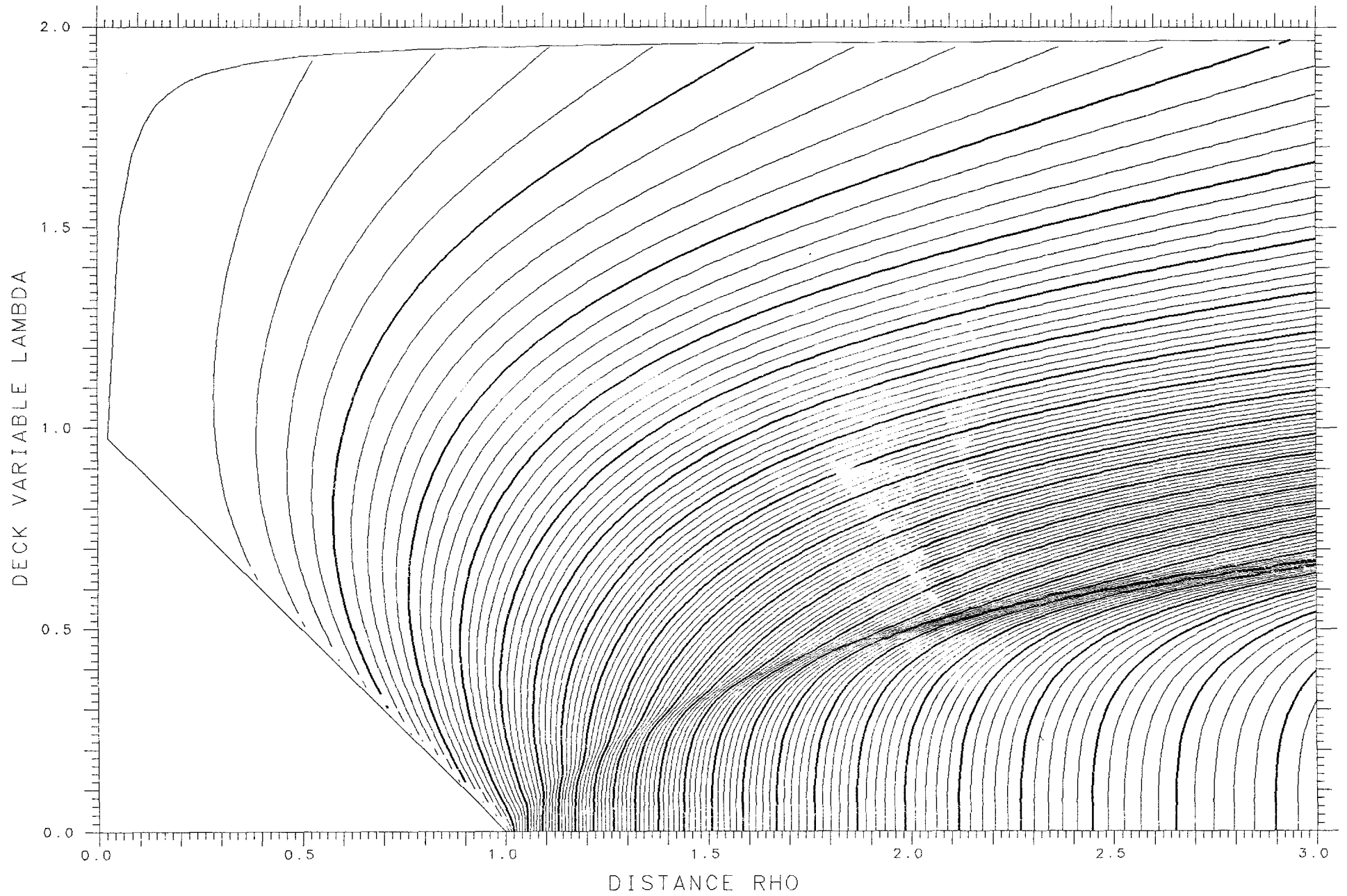

DECK VARIABLE LAMBDA

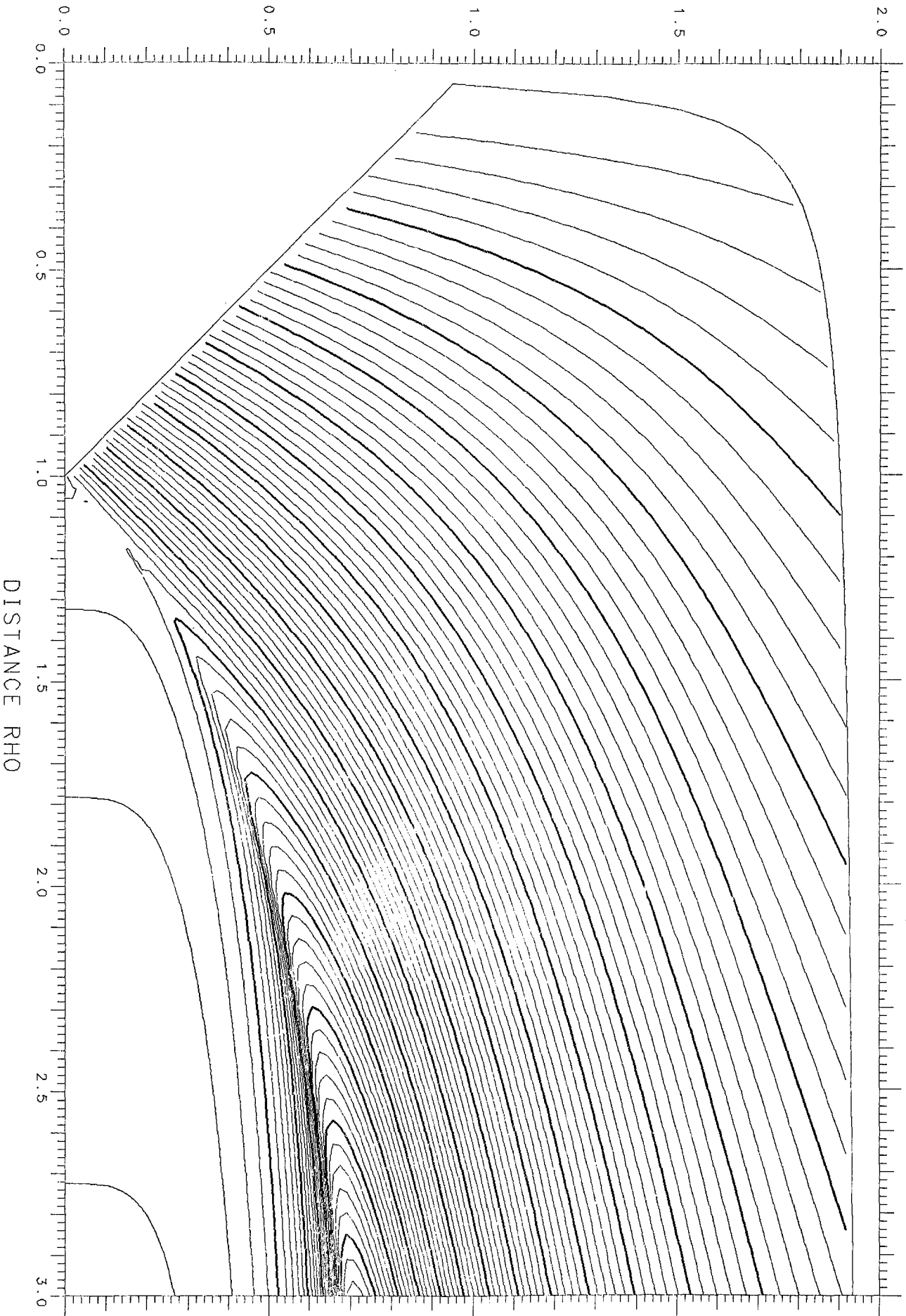

X = .050 ASYMMETRY DELTA = .050 FRACTIONAL = .5745
SPHERES .22057 TANGENT .24630 LENGTH 4.260 ENERGY 86.48 SPACING .005

X=1.500 ASYMMETRY DELTA=0. FRACTIONAL= .5000
SPHERES -.85020 TANGENT -.06275 LENGTH 15.567 ENERGY 980.15 SPACING .005

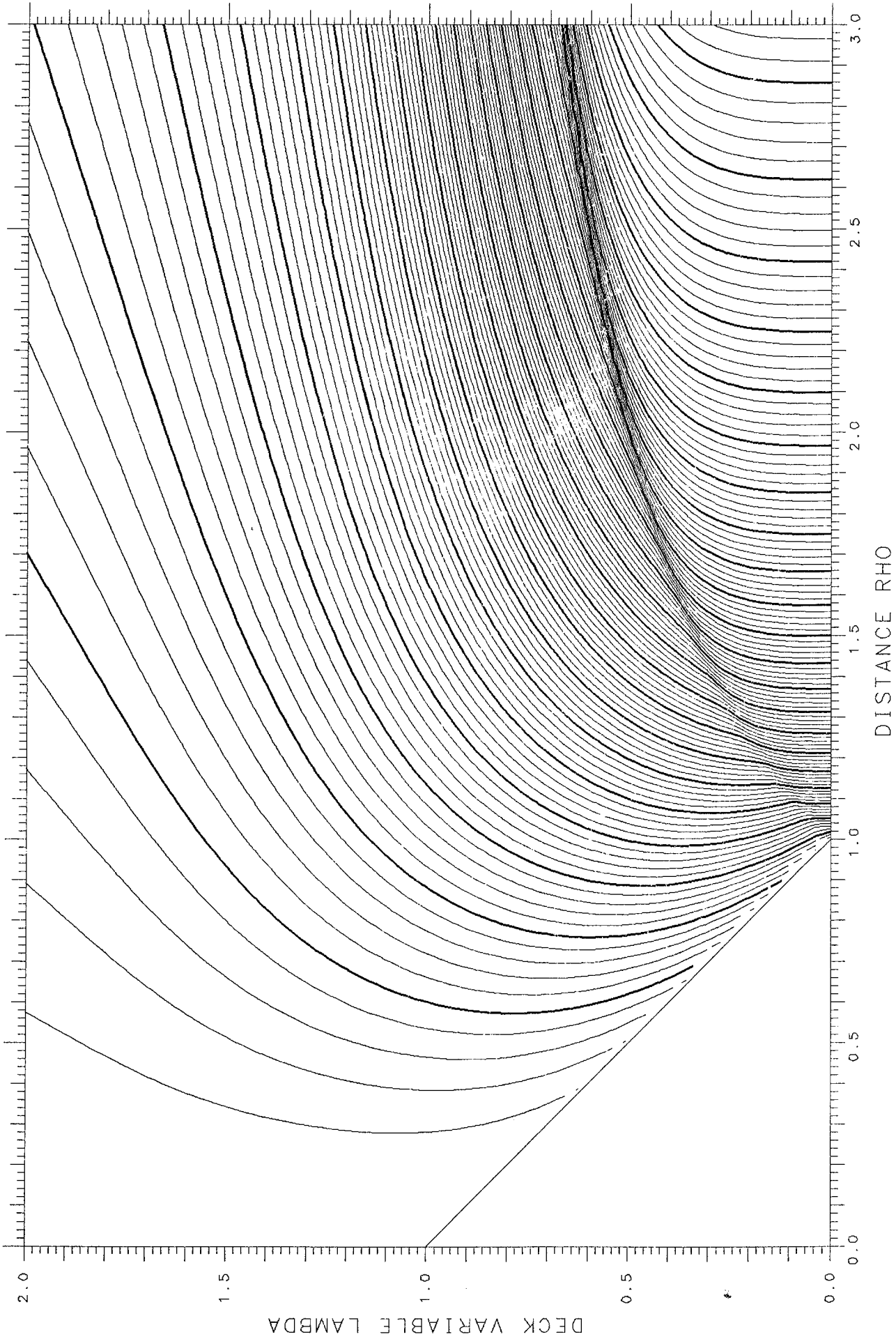

X= .050 ASYMMETRY DELTA= .075 FRACTIONAL= .6108

SPHERES .21767 TANGENT .24277 LENGTH 4.247 ENERGY 86.48 SPACING .005

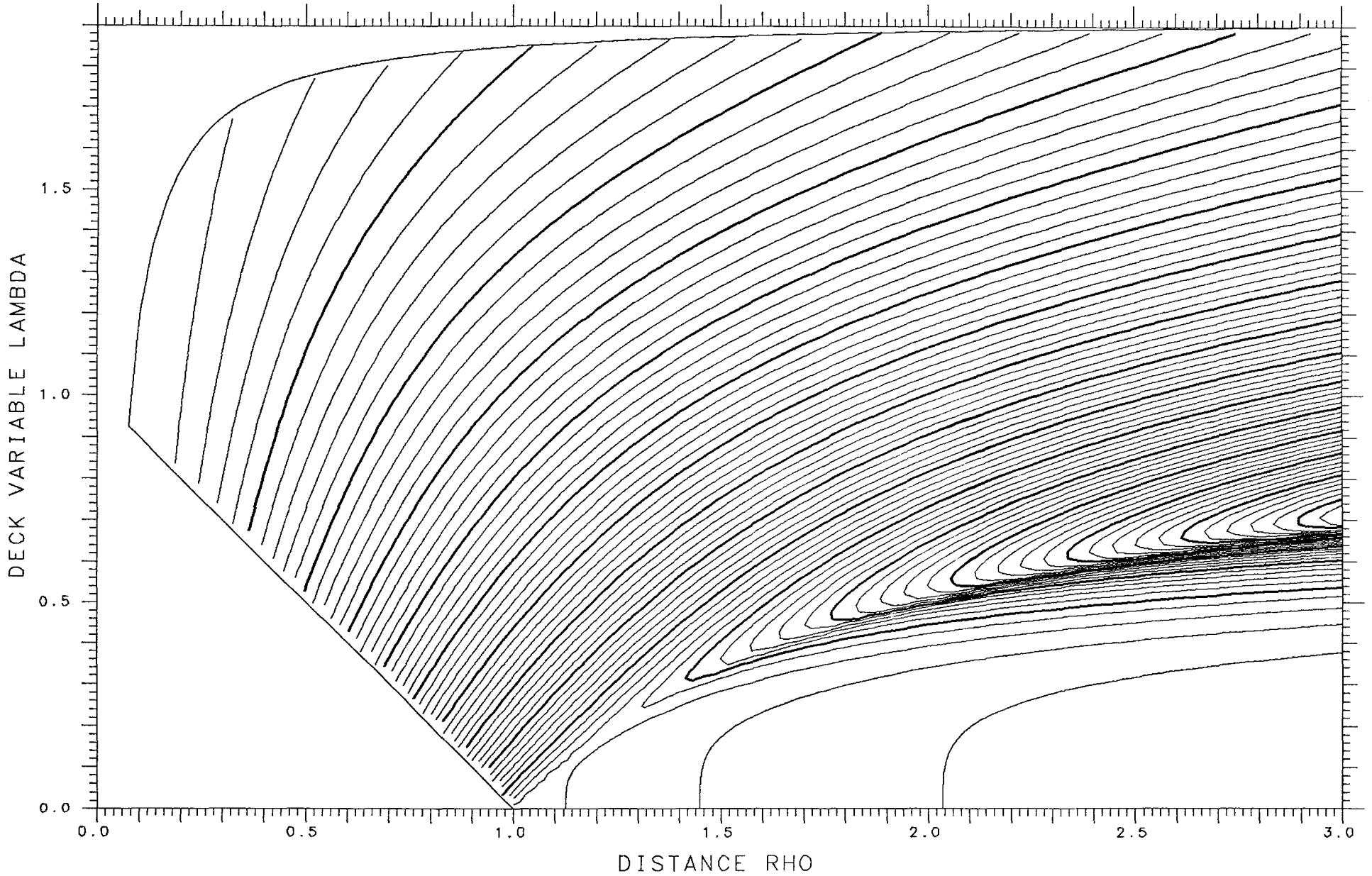

X=1.450

ASYMMETRY DELTA= .075

FRACTIONAL= .6108

SPHERES -.77019

TANGENT -.04235

LENGTH 15.280

ENERGY 958.62

SPACING .005

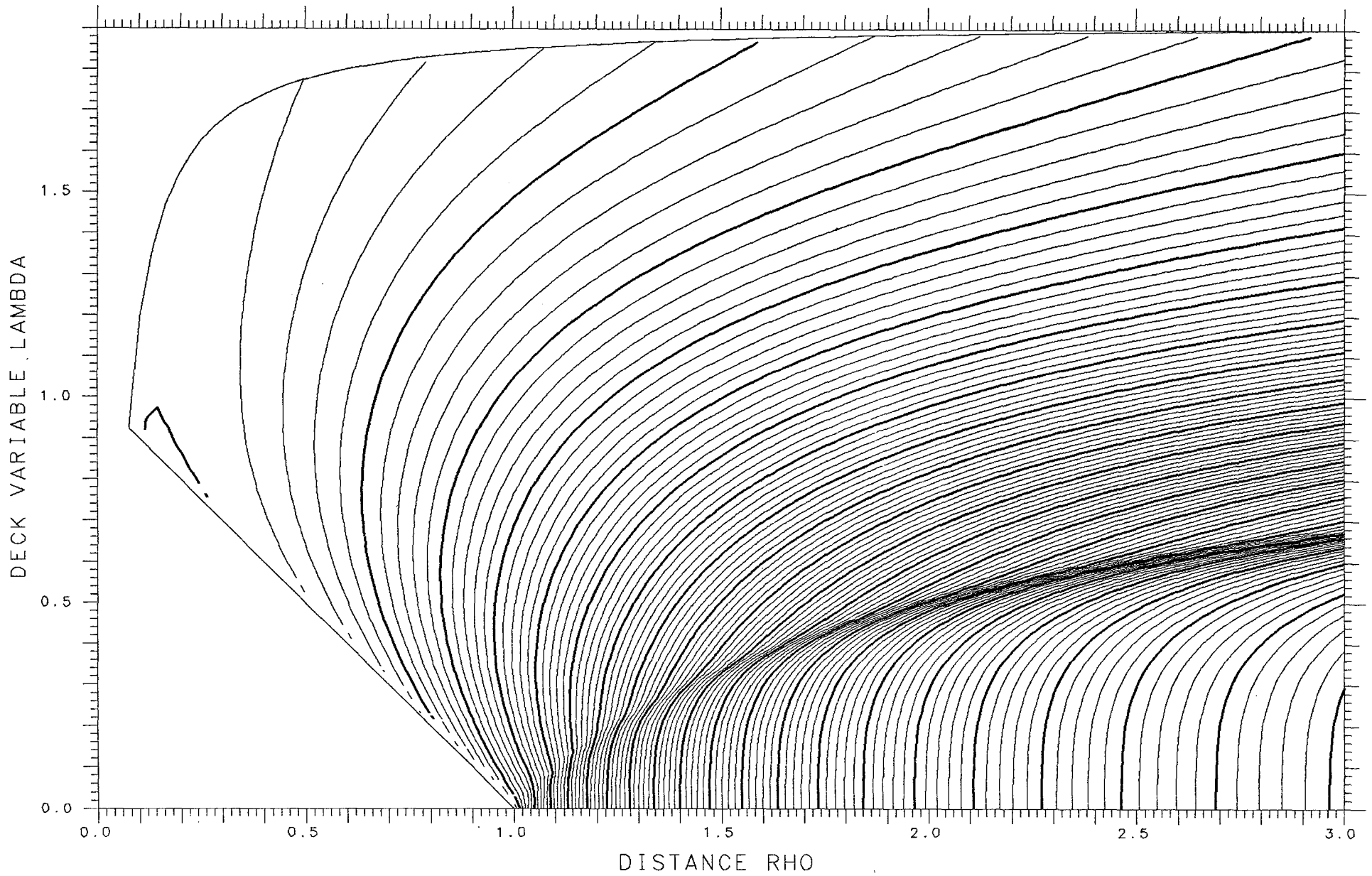

X= .050 ASYMMETRY DELTA= .100 FRACTIONAL= .6461

SPHERES .21368 TANGENT .23793 LENGTH 4.229 ENERGY 86.48 SPACING .005

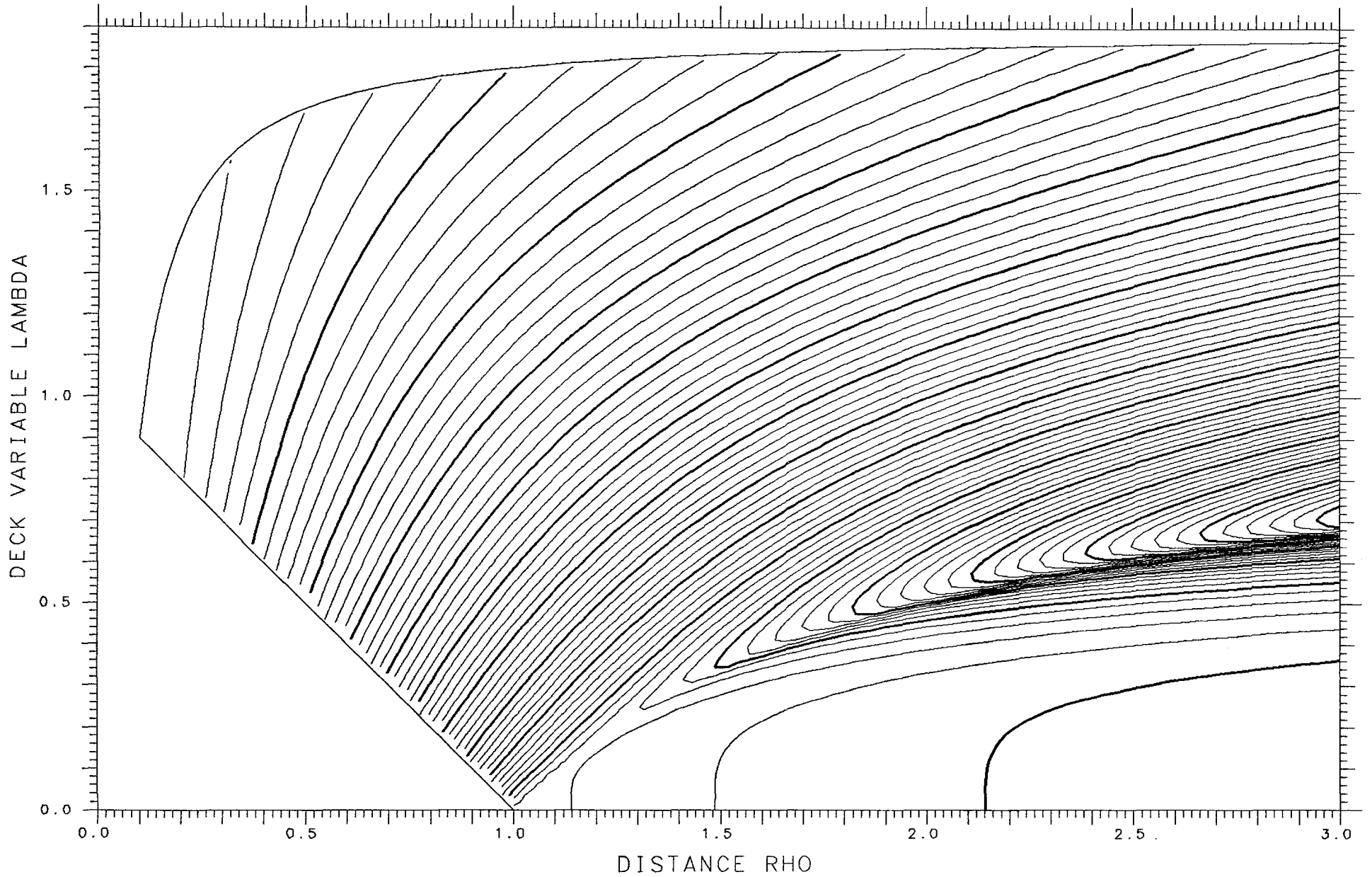

X=1.450

ASYMMETRY DELTA= .050

FRACTIONAL= .5745

SPHERES -.79377

TANGENT -.04761

LENGTH 15.328

ENERGY 958.62

SPACING .005

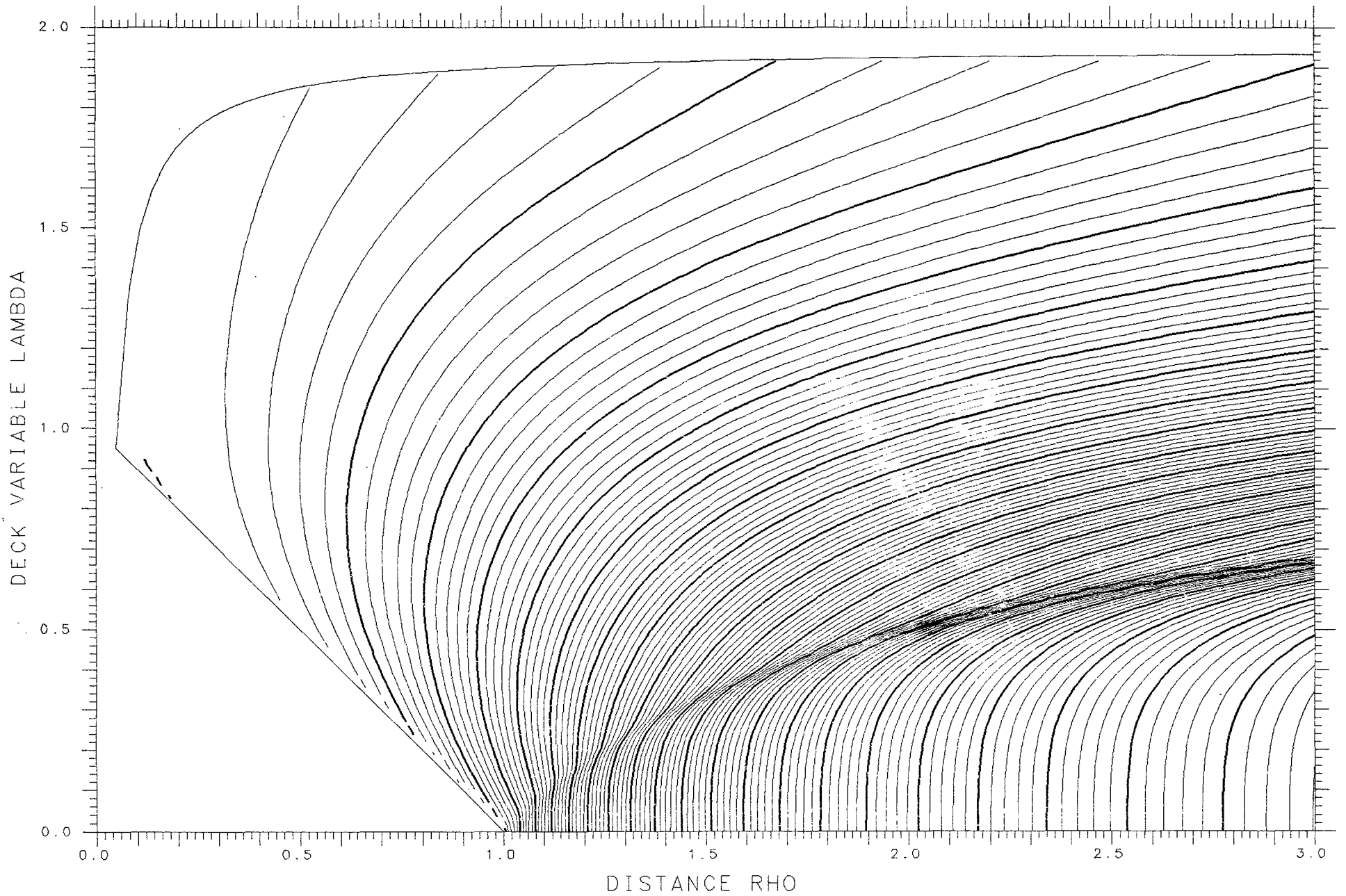

X= .050 ASYMMETRY DELTA= .125 FRACTIONAL= .6800

SPHERES .20868 TANGENT .23187 LENGTH 4.206 ENERGY 86.48 SPACING .005

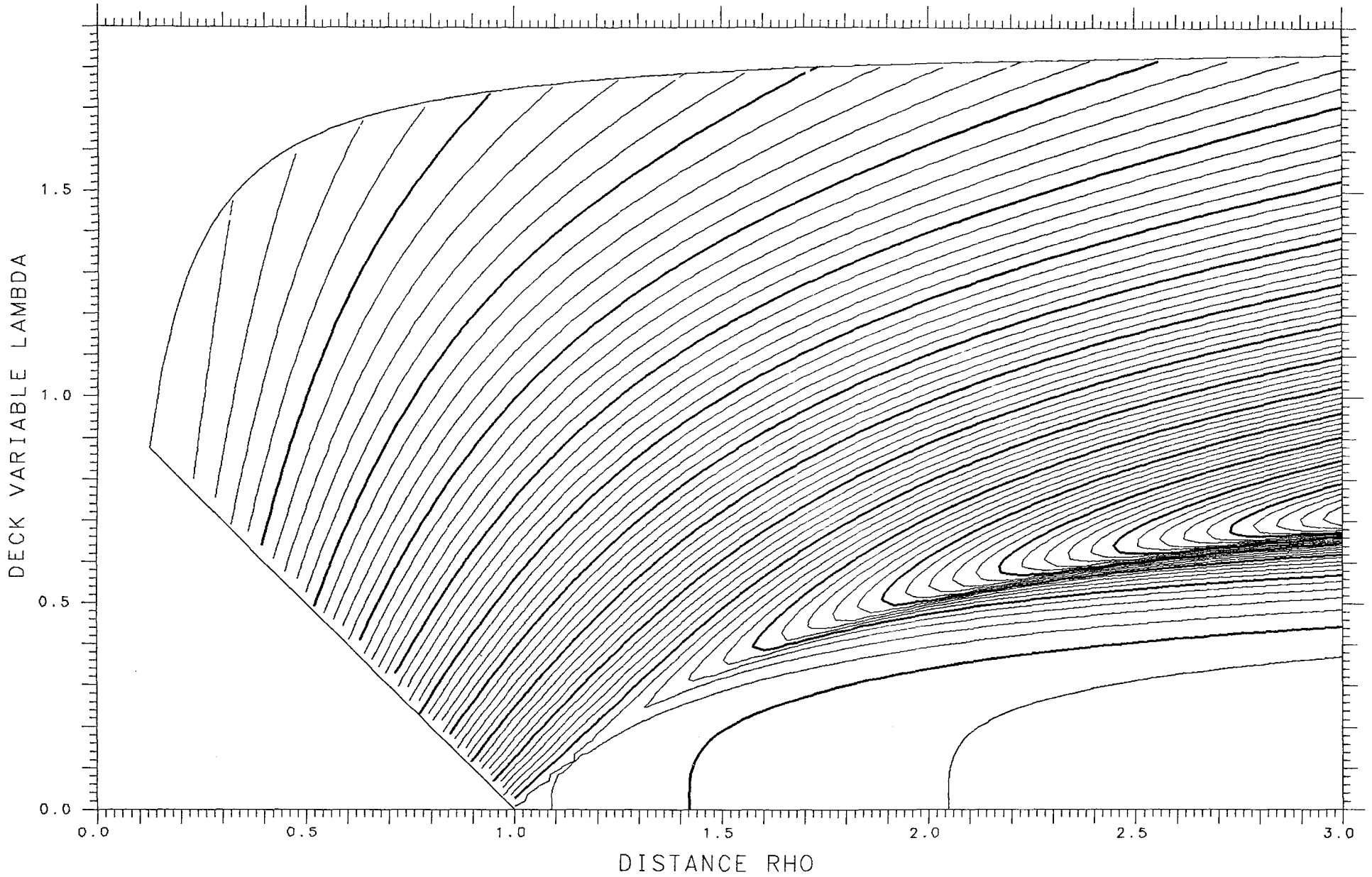

X=1.450 ASYMMETRY DELTA= .025 FRACTIONAL= .5374

SPHERES -.80828 TANGENT -.05088 LENGTH 15.356 ENERGY 958.62 SPACING .005

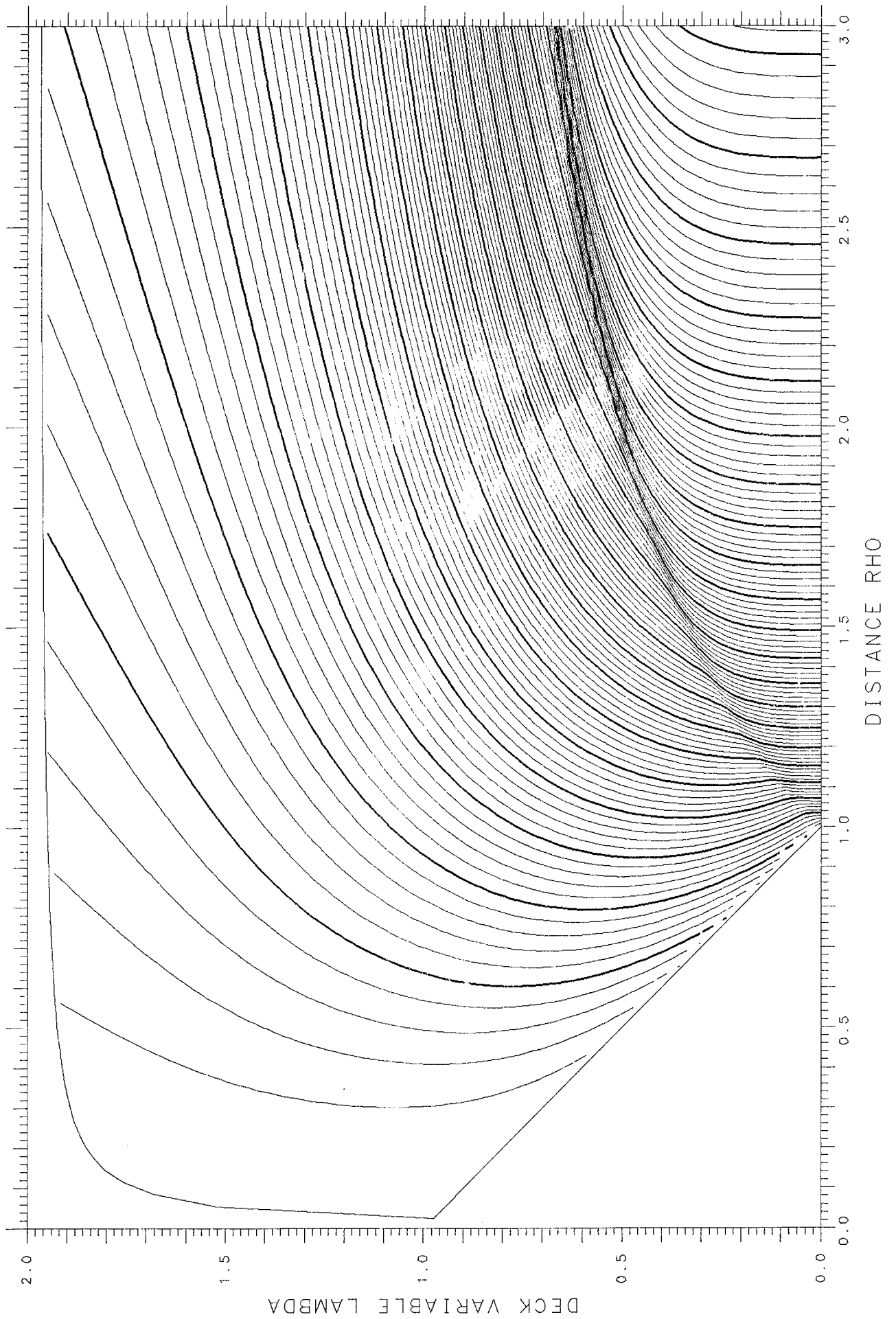

X= .050 ASYMMETRY DELTA= .150 FRACTIONAL= .7124
SPHERES .20273 TANGENT .22471 LENGTH 4.178 ENERGY 86.48 SPACING .005

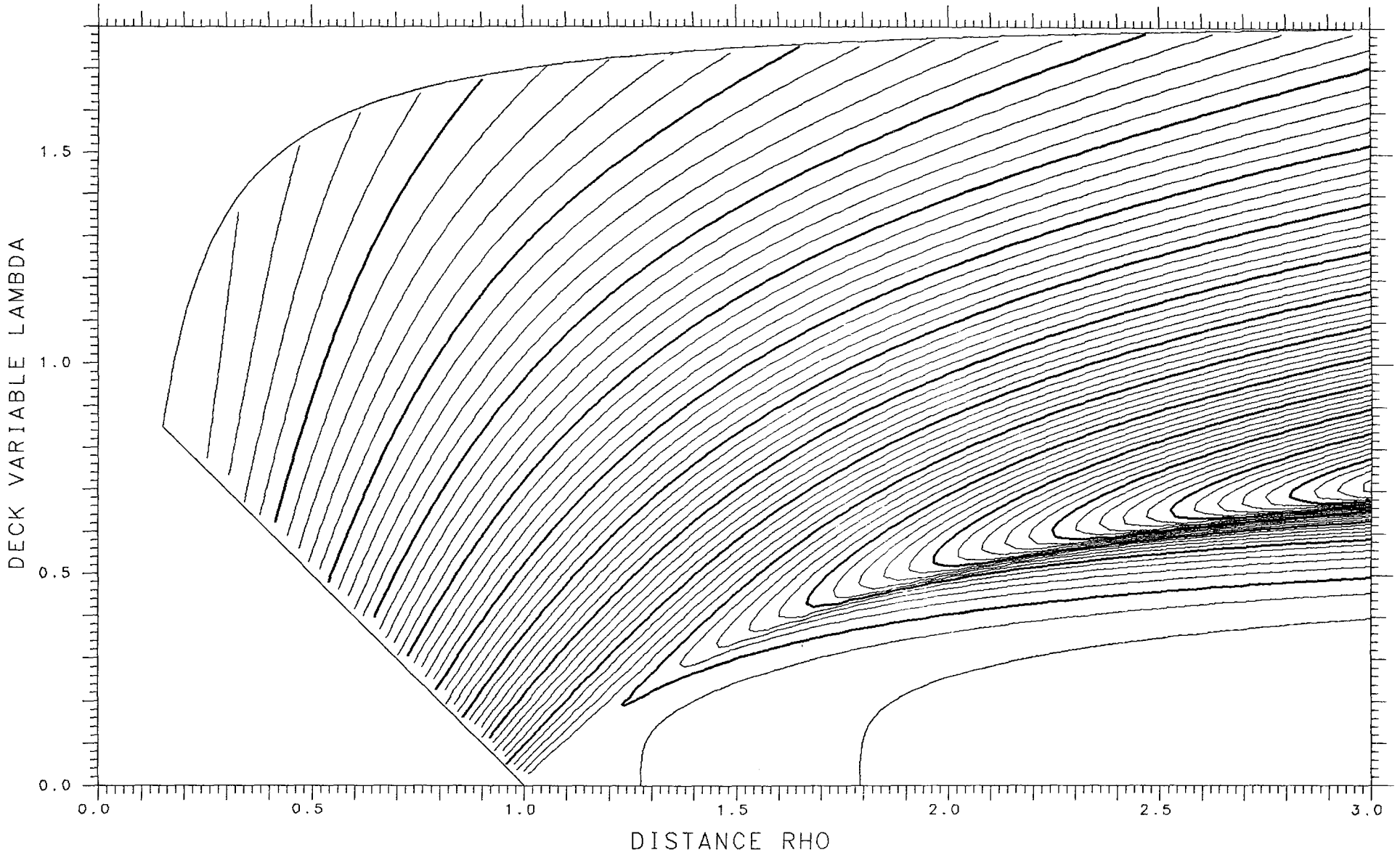

X=1.450

ASYMMETRY DELTA=0.

FRACTIONAL= .5000

SPHERES -.81319

TANGENT -.05199

LENGTH 15.366

ENERGY 958.62

SPACING .005

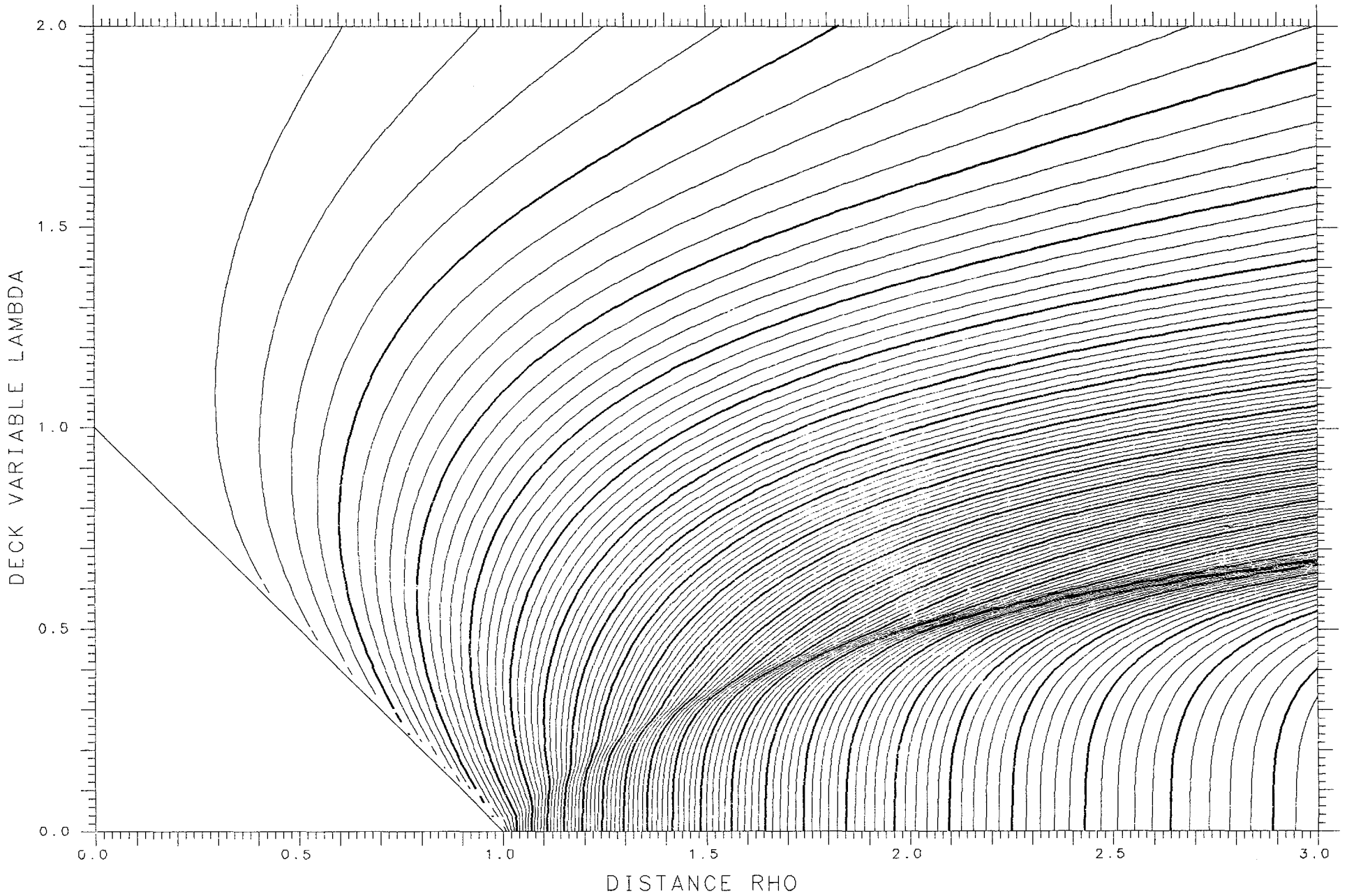

X= .100

ASYMMETRY DELTA=0.

FRACTIONAL= .5000

SPHERES .18591

TANGENT .23841

LENGTH 5.449

ENERGY 140.52

SPACING .005

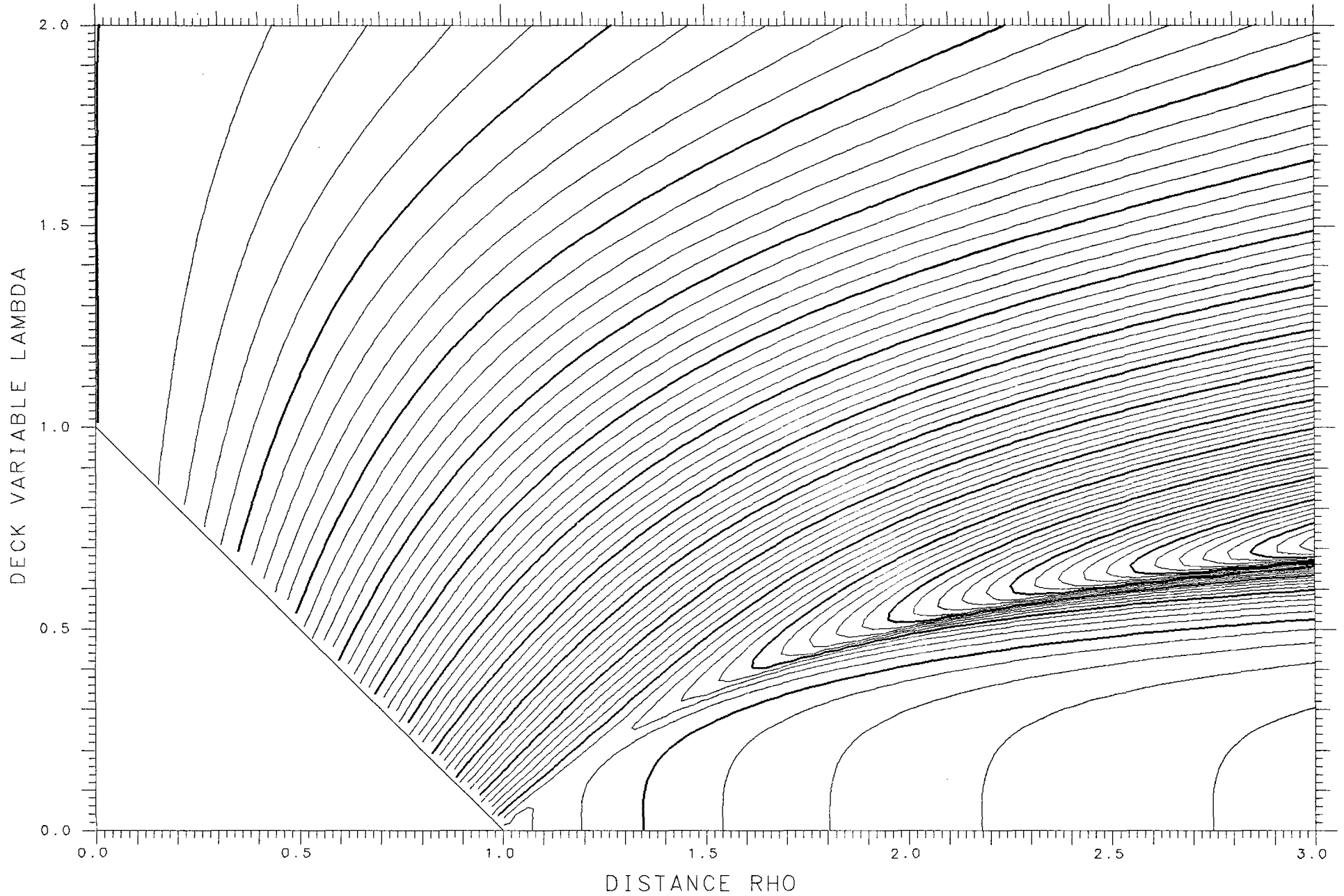

X=1.400

ASYMMETRY DELTA= .075

FRACTIONAL= .6108

SPHERES -.73491

TANGENT -.03217

LENGTH 15.075

ENERGY 936.78

SPACING .005

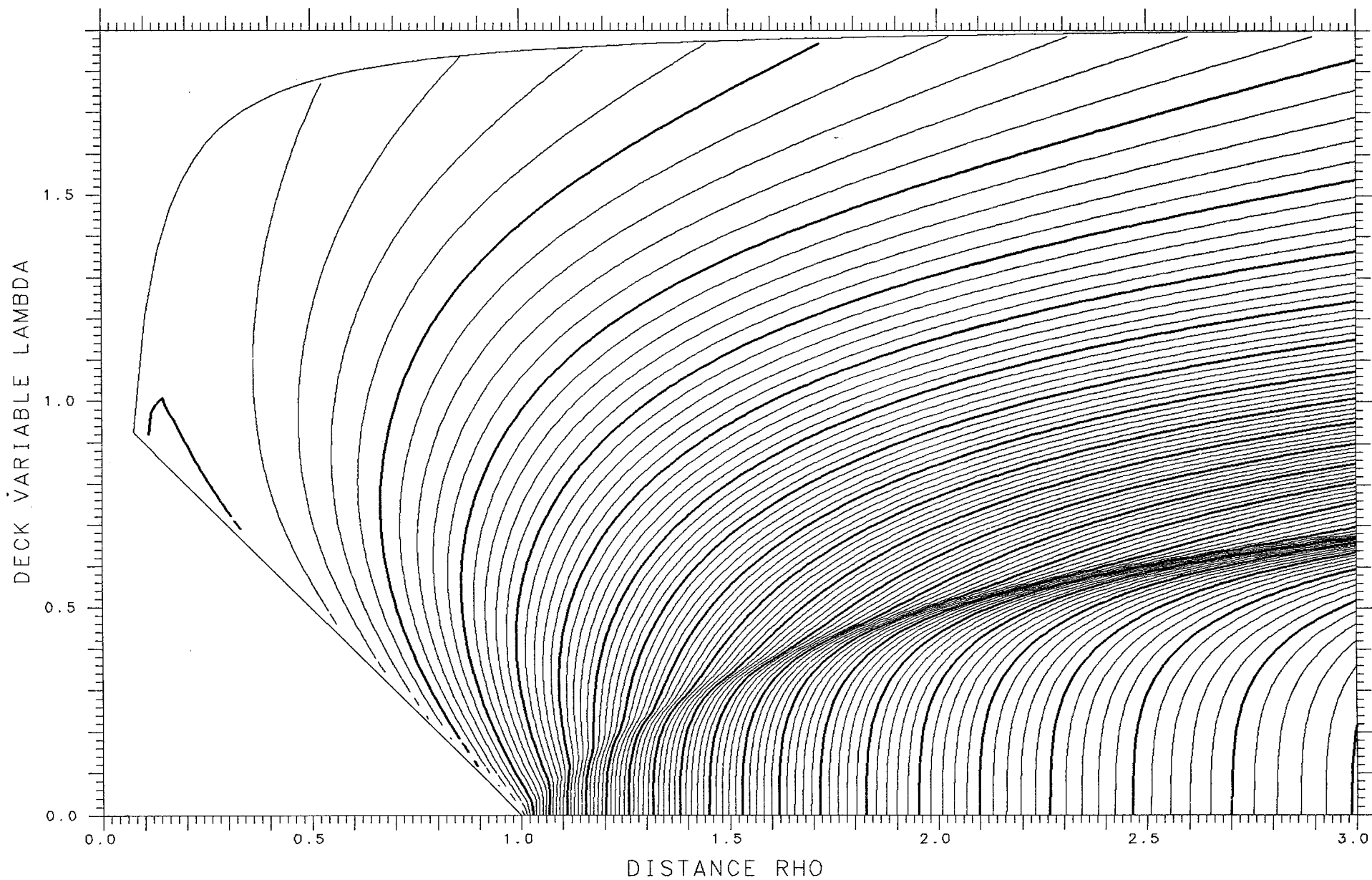

X= .100

ASYMMETRY DELTA= .025 FRACTIONAL= .5374

SPHERES .18552

TANGENT .23775

LENGTH 5.446

ENERGY 140.52

SPACING .005

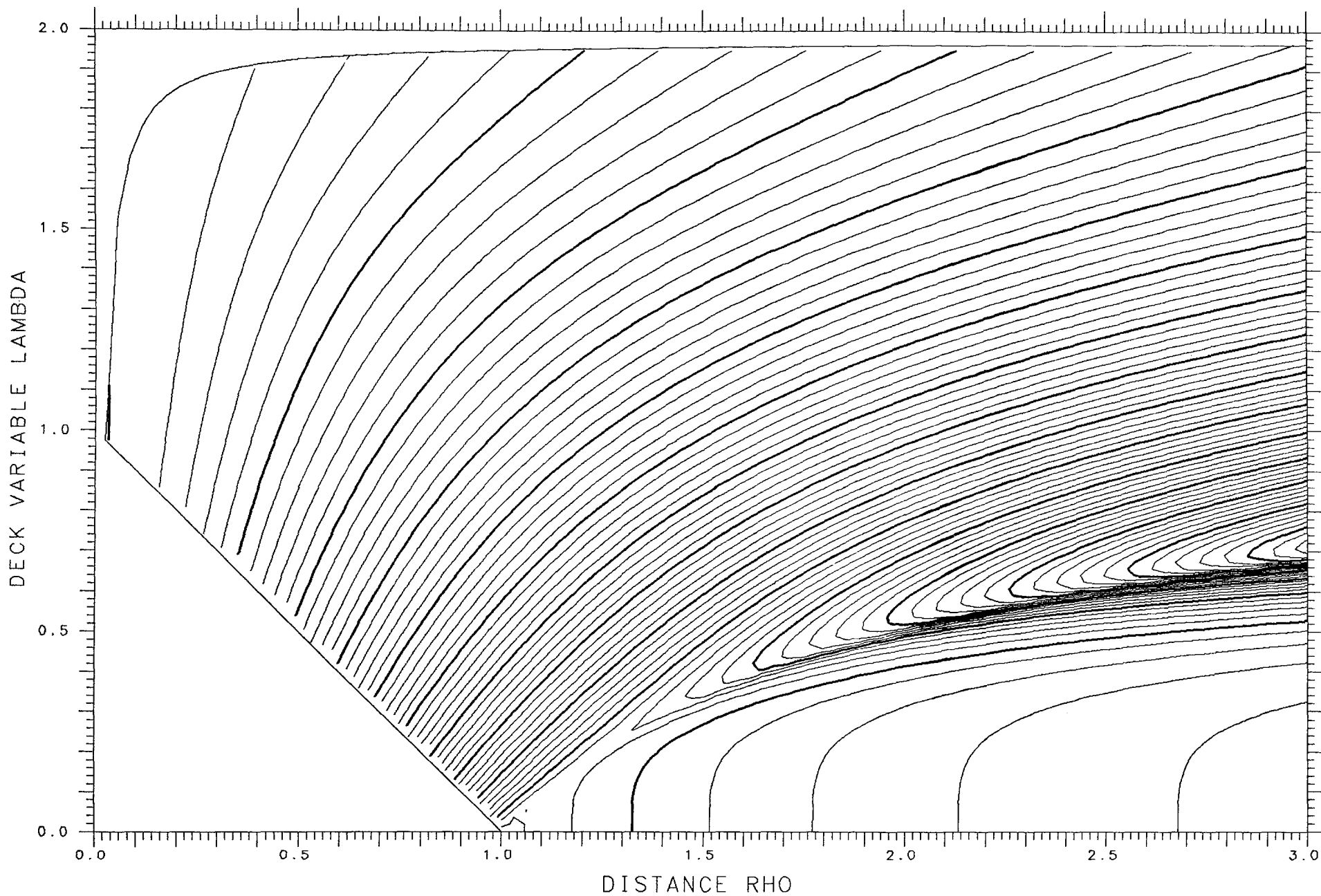

X=1.400

ASYMMETRY DELTA= .050

FRACTIONAL= .5745

SPHERES -.75754

TANGENT -.03711

LENGTH 15.122

ENERGY 936.78

SPACING .005

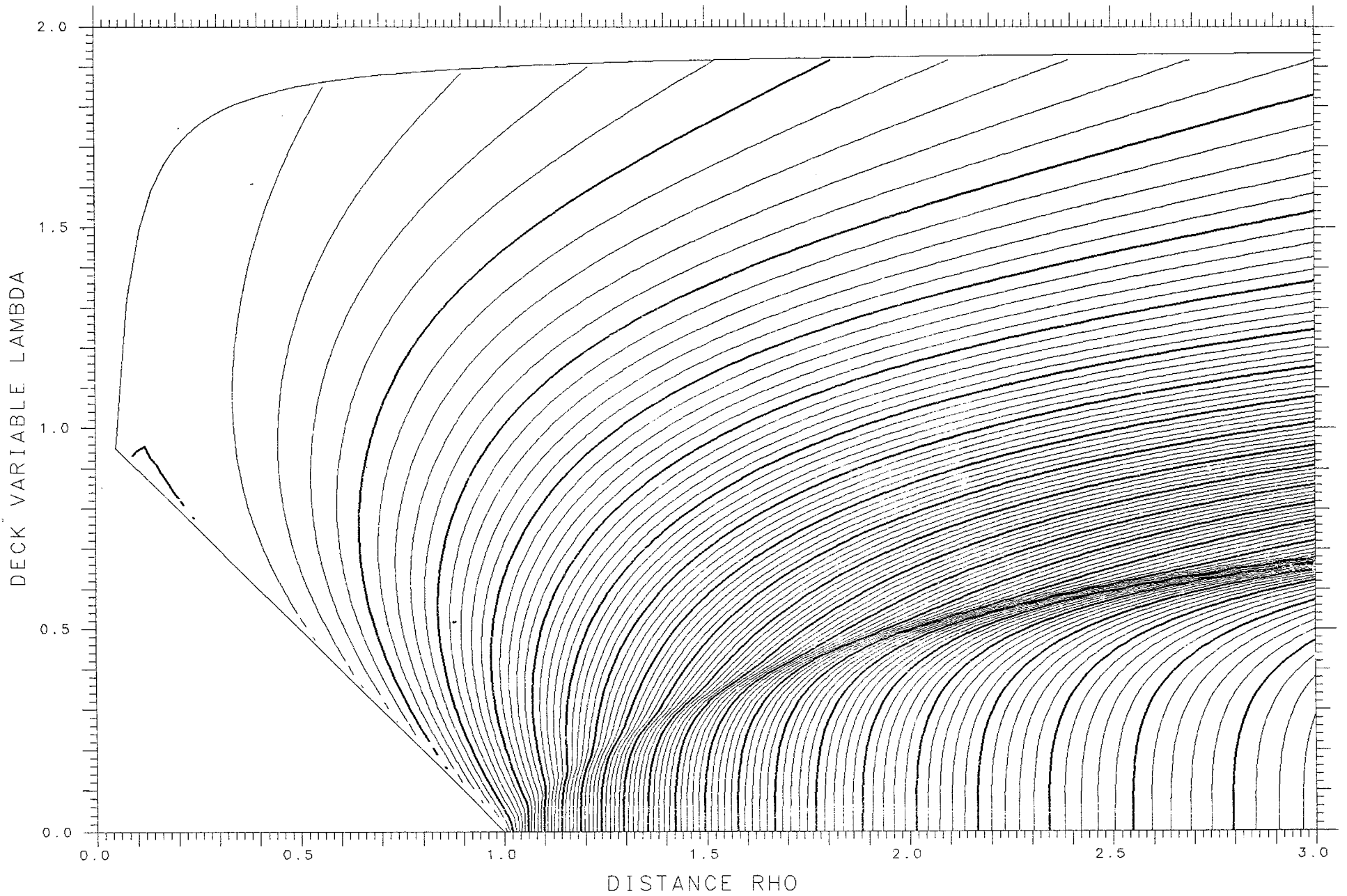

DECK VARIABLE LAMBDA

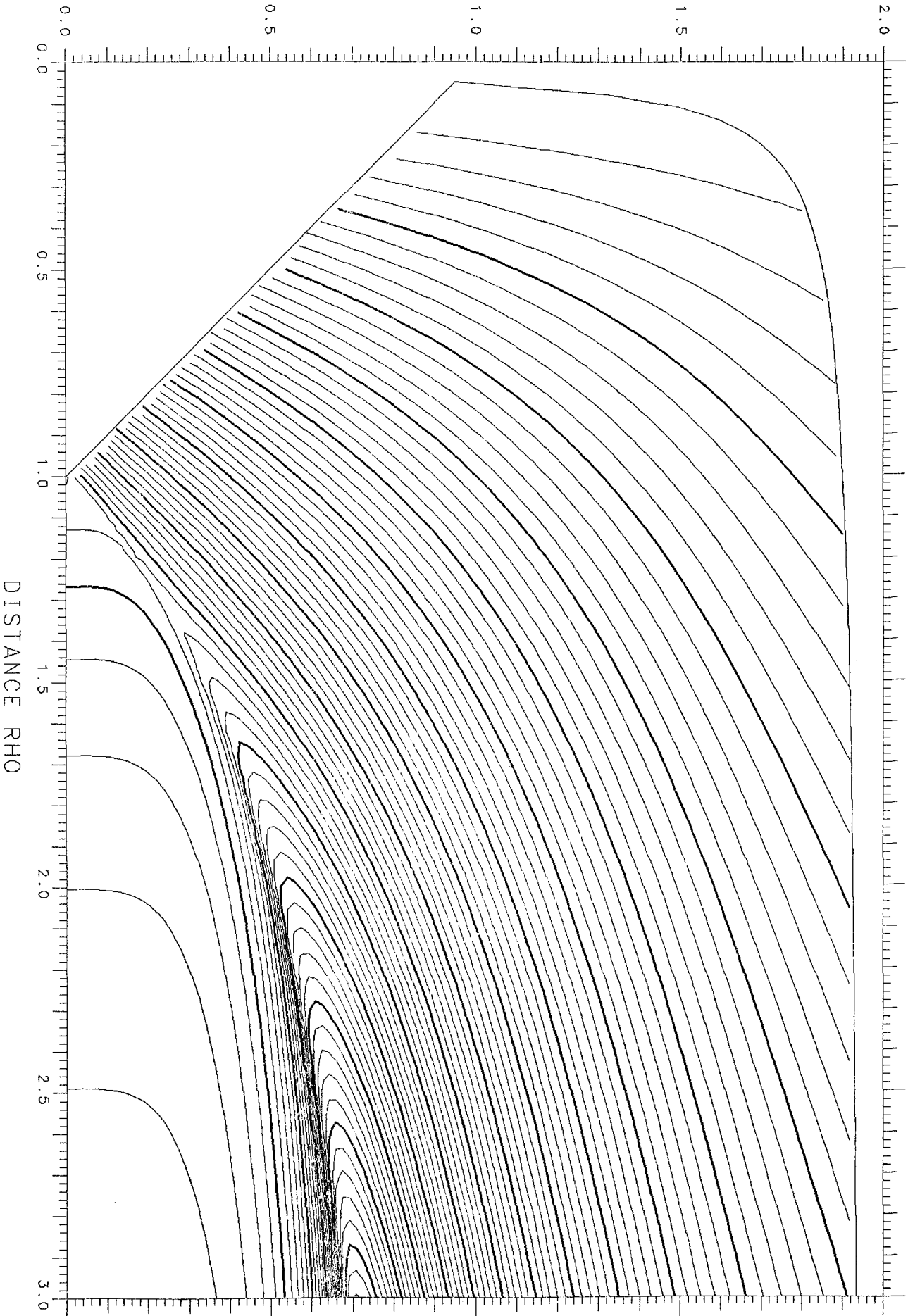

X = .100 ASYMMETRY DELTA = .050 FRACTIONAL = .5745
SPHERES .18434 TANGENT .23580 LENGTH 5.436 ENERGY 140.52 SPACING .005

X=1.400 ASYMMETRY DELTA= .025 FRACTIONAL= .5374
SPHERES -.77148 TANGENT -.04019 LENGTH 15.150 ENERGY 936.78 SPACING .005

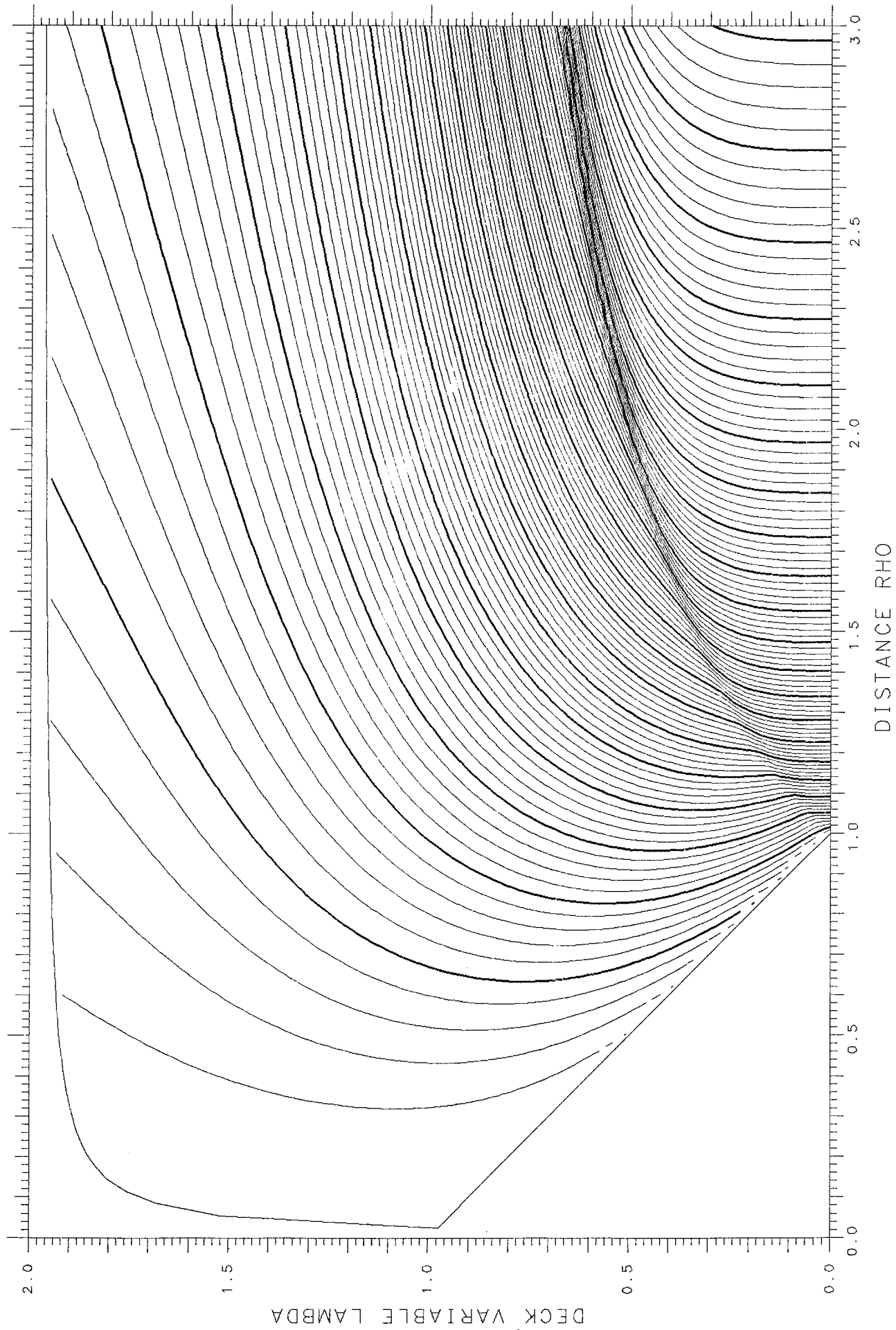

X= .100

ASYMMETRY DELTA= .075

FRACTIONAL= .6108

SPHERES .18239

TANGENT .23259

LENGTH 5.419

ENERGY 140.52

SPACING .005

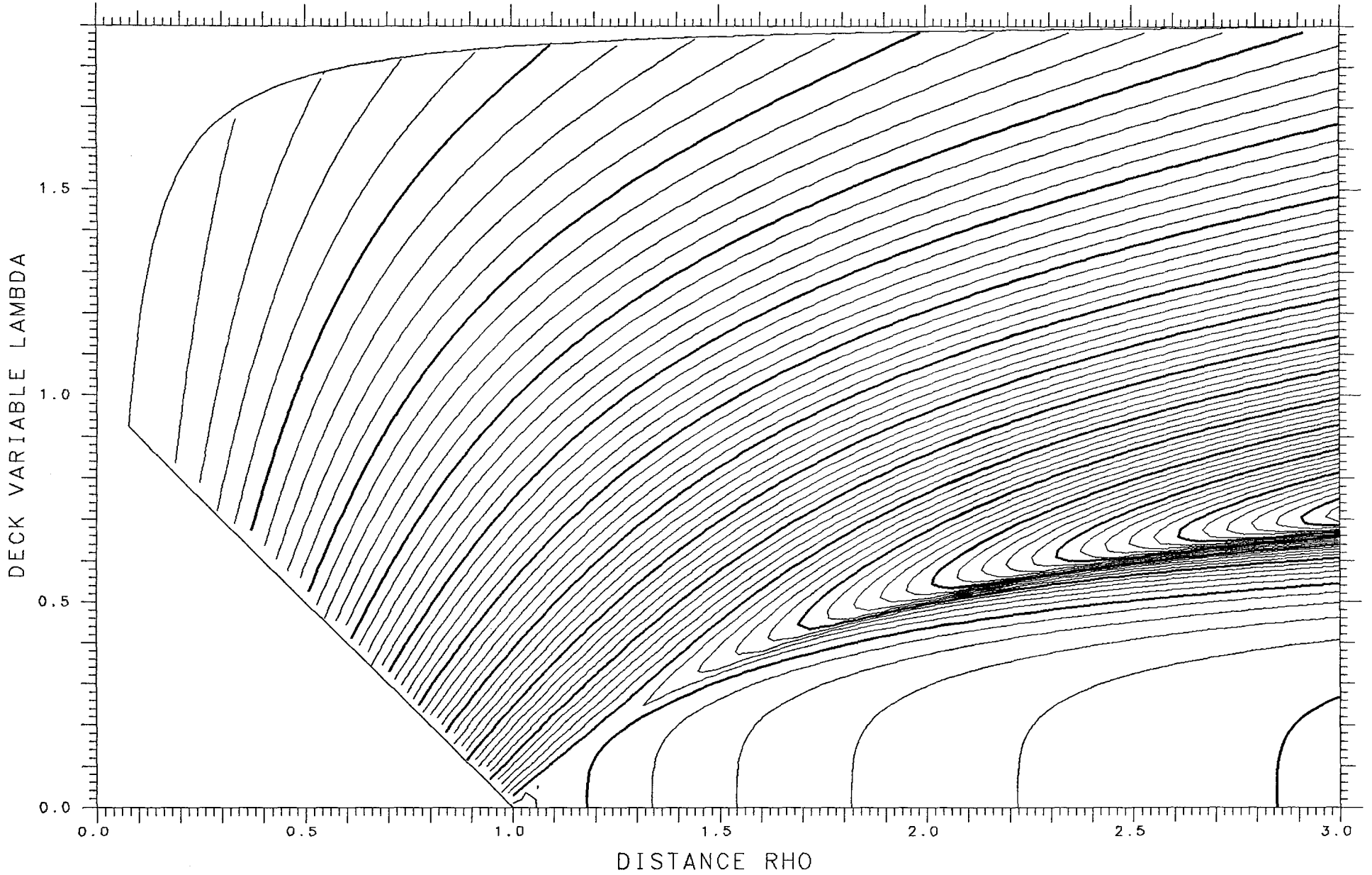

X=1.400

ASYMMETRY DELTA=0.

FRACTIONAL= .5000

SPHERES -.77619

TANGENT -.04124

LENGTH 15.160

ENERGY 936.78

SPACING .005

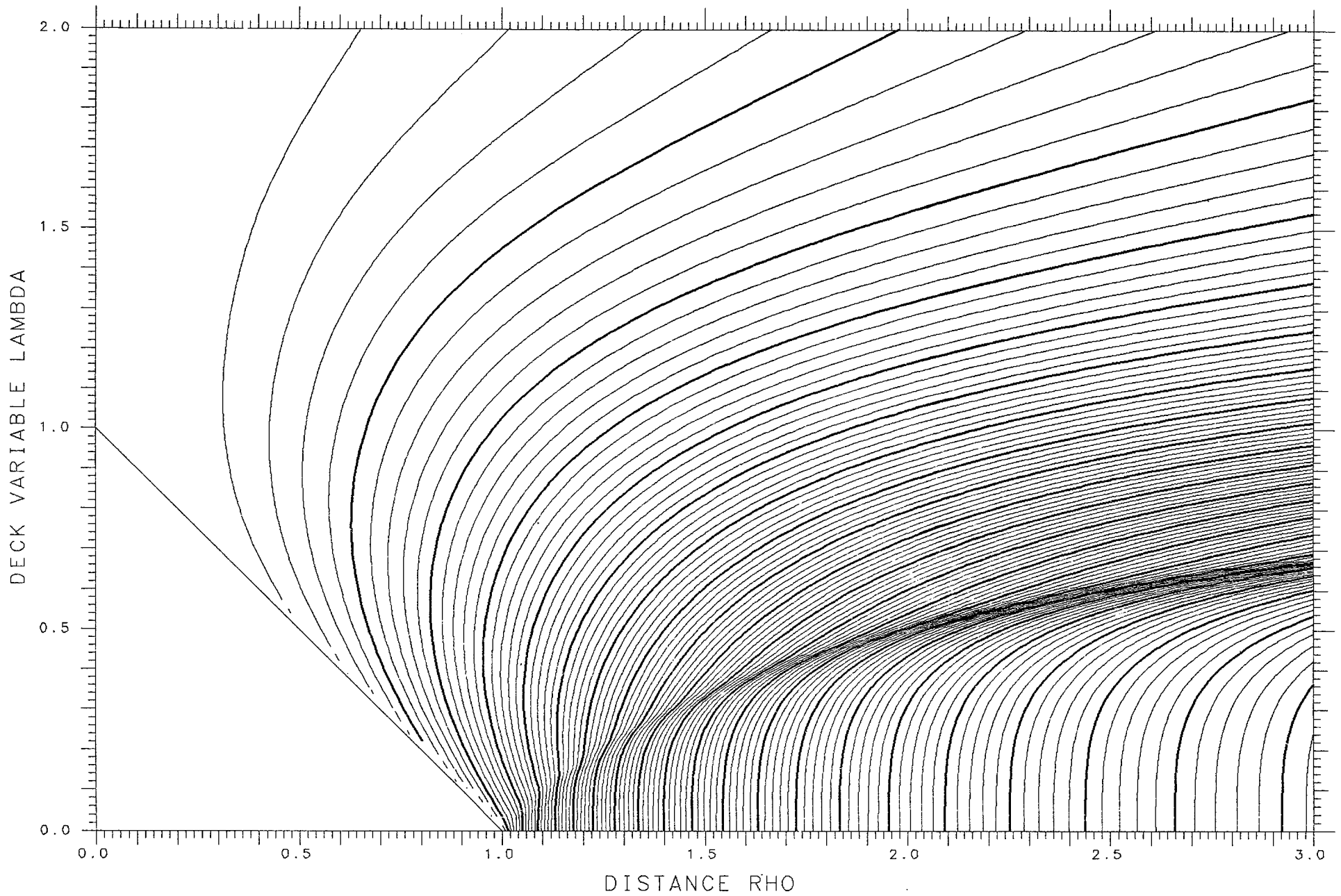

X= .100 ASYMMETRY DELTA= .100 FRACTIONAL= .6461

SPHERES .17968 TANGENT .22817 LENGTH 5.396 ENERGY 140.52 SPACING .005

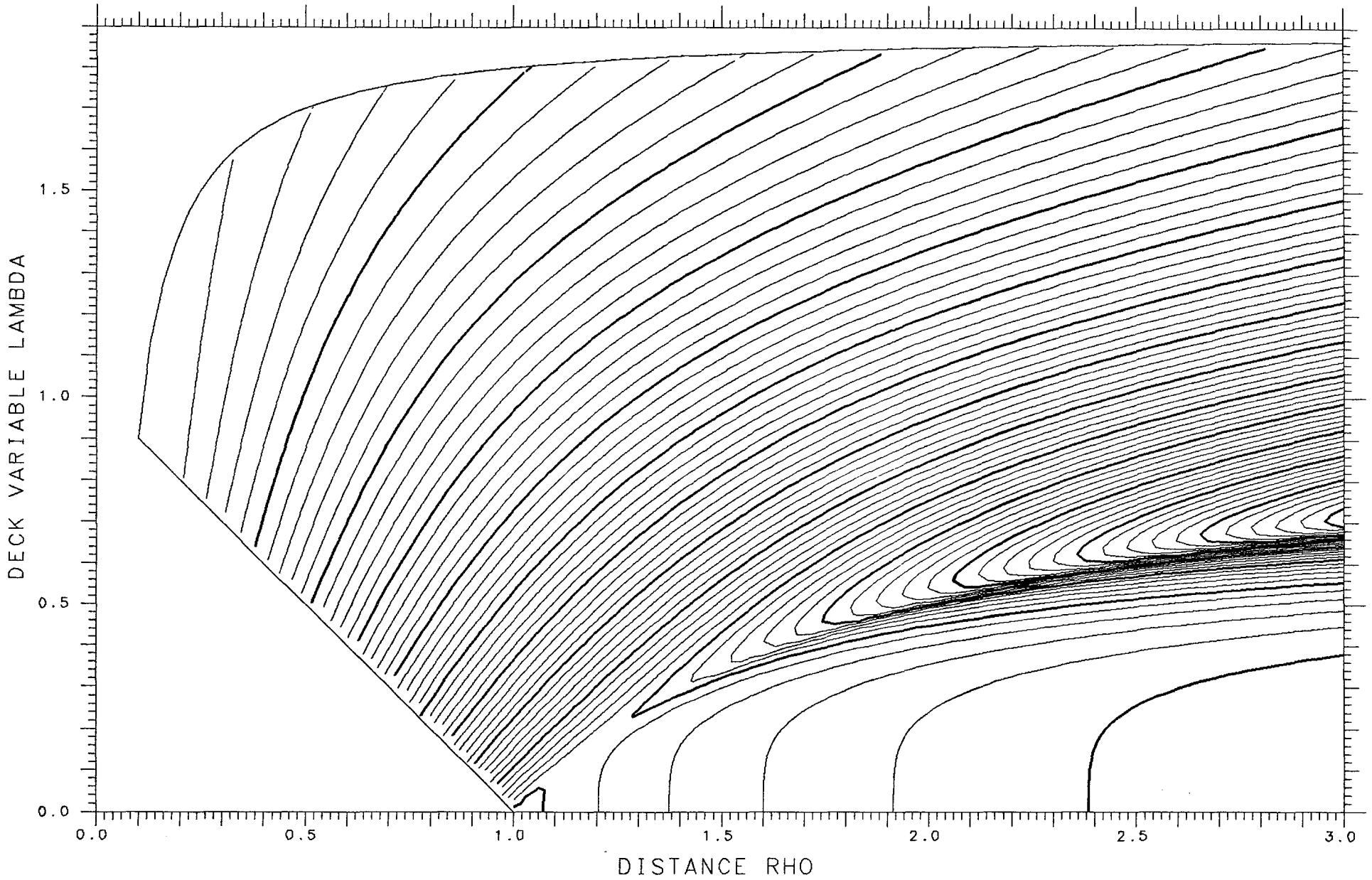

X=1.350

ASYMMETRY DELTA= .100

FRACTIONAL= .6461

SPHERES -.67046

TANGENT -.01586

LENGTH 14.802

ENERGY 914.60

SPACING .005

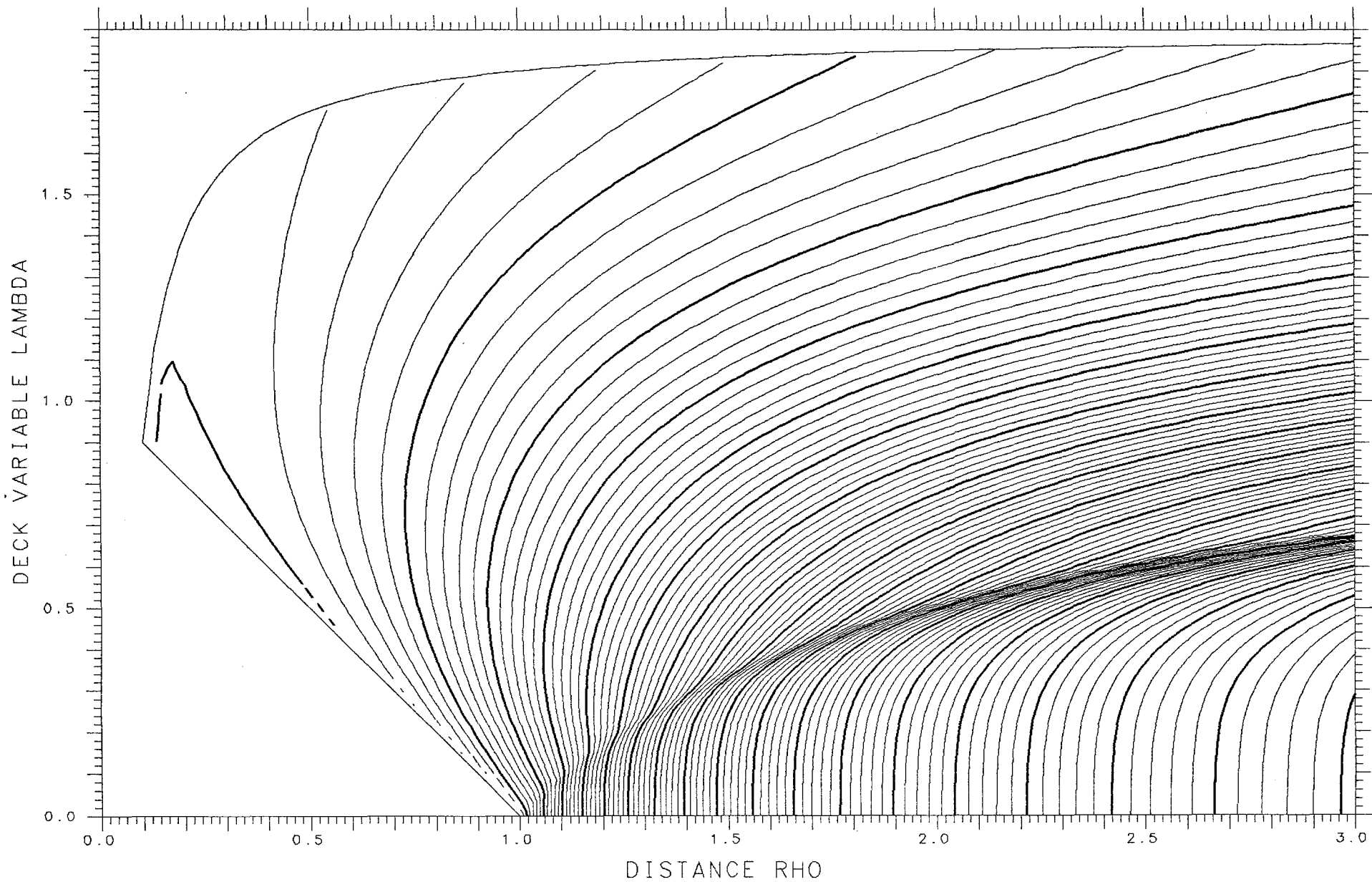

X= .100

ASYMMETRY DELTA= .125

FRACTIONAL= .6800

SPHERES .17623

TANGENT .22262

LENGTH 5.367

ENERGY 140.52

SPACING .005

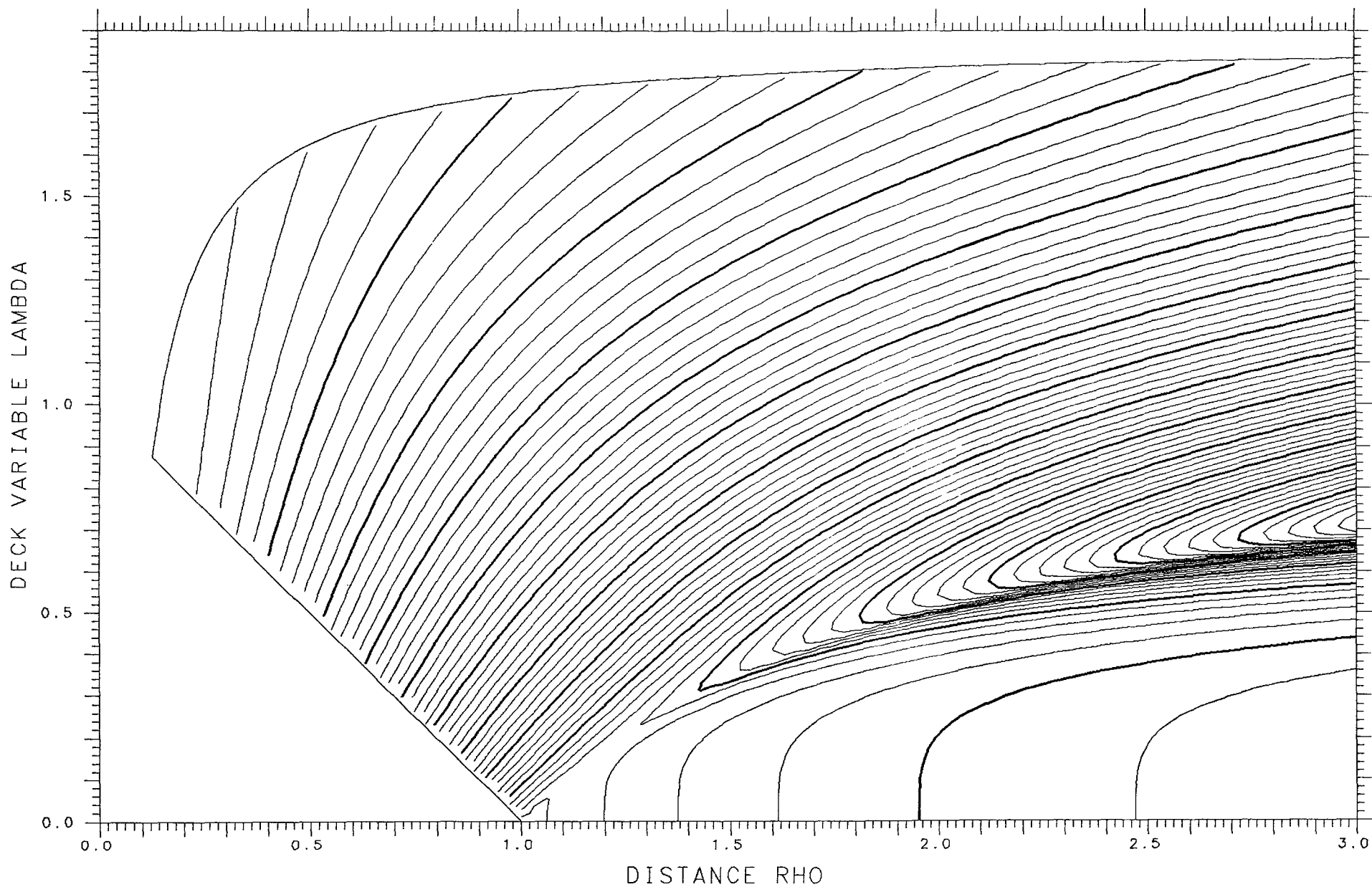

X=1.350

ASYMMETRY DELTA= .075 FRACTIONAL= .6108

SPHERES -.69963

TANGENT -.02199

LENGTH 14.865

ENERGY 914.60

SPACING .005

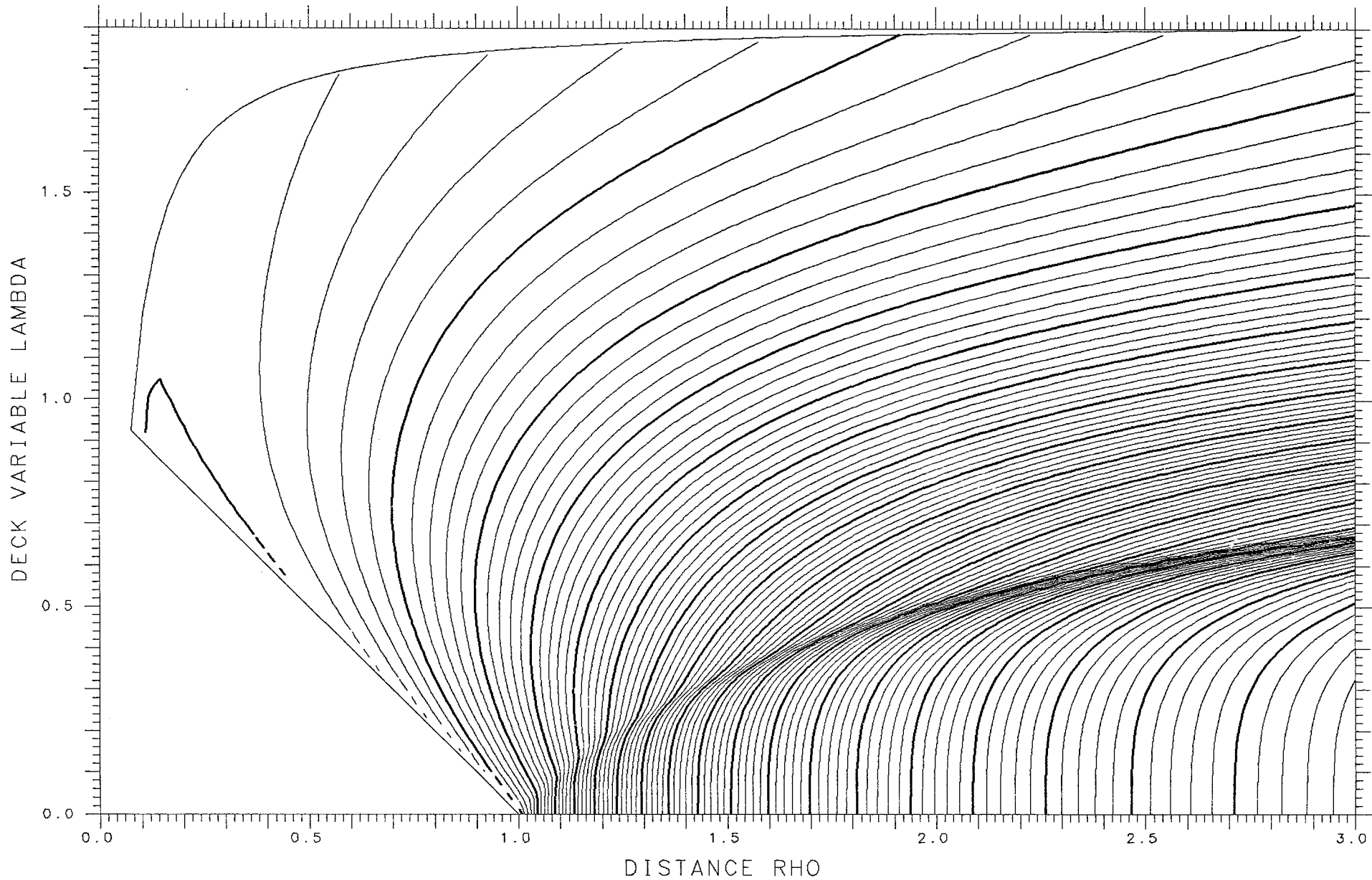

X= .100 ASYMMETRY DELTA= .150 FRACTIONAL= .7124

SPHERES .17208 TANGENT .21605 LENGTH 5.332 ENERGY 140.52 SPACING .005

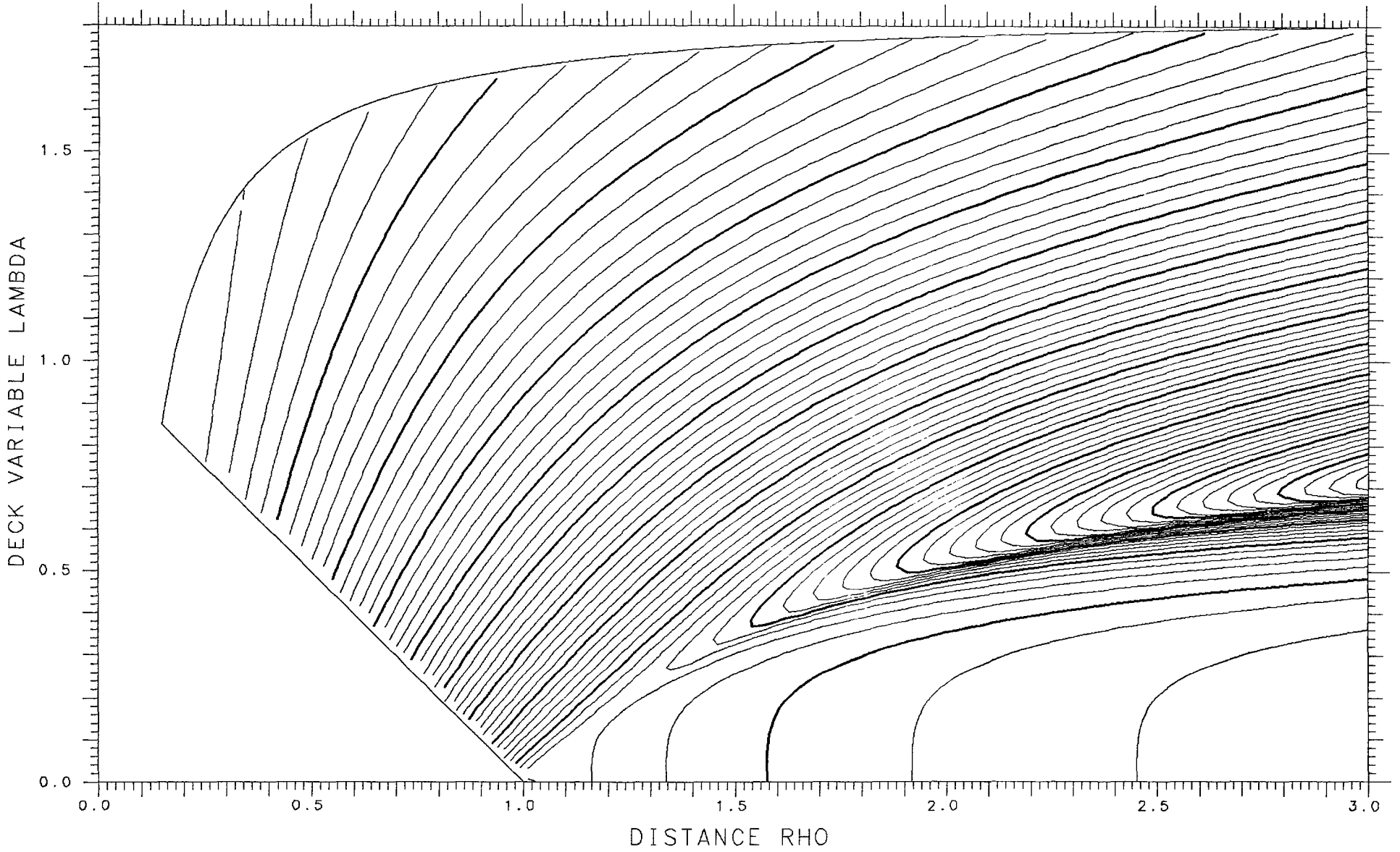

X=1.350 ASYMMETRY DELTA= .050 FRACTIONAL= .5745

SPHERES -.72131 TANGENT -.02662 LENGTH 14.911 ENERGY 914.60 SPACING .005

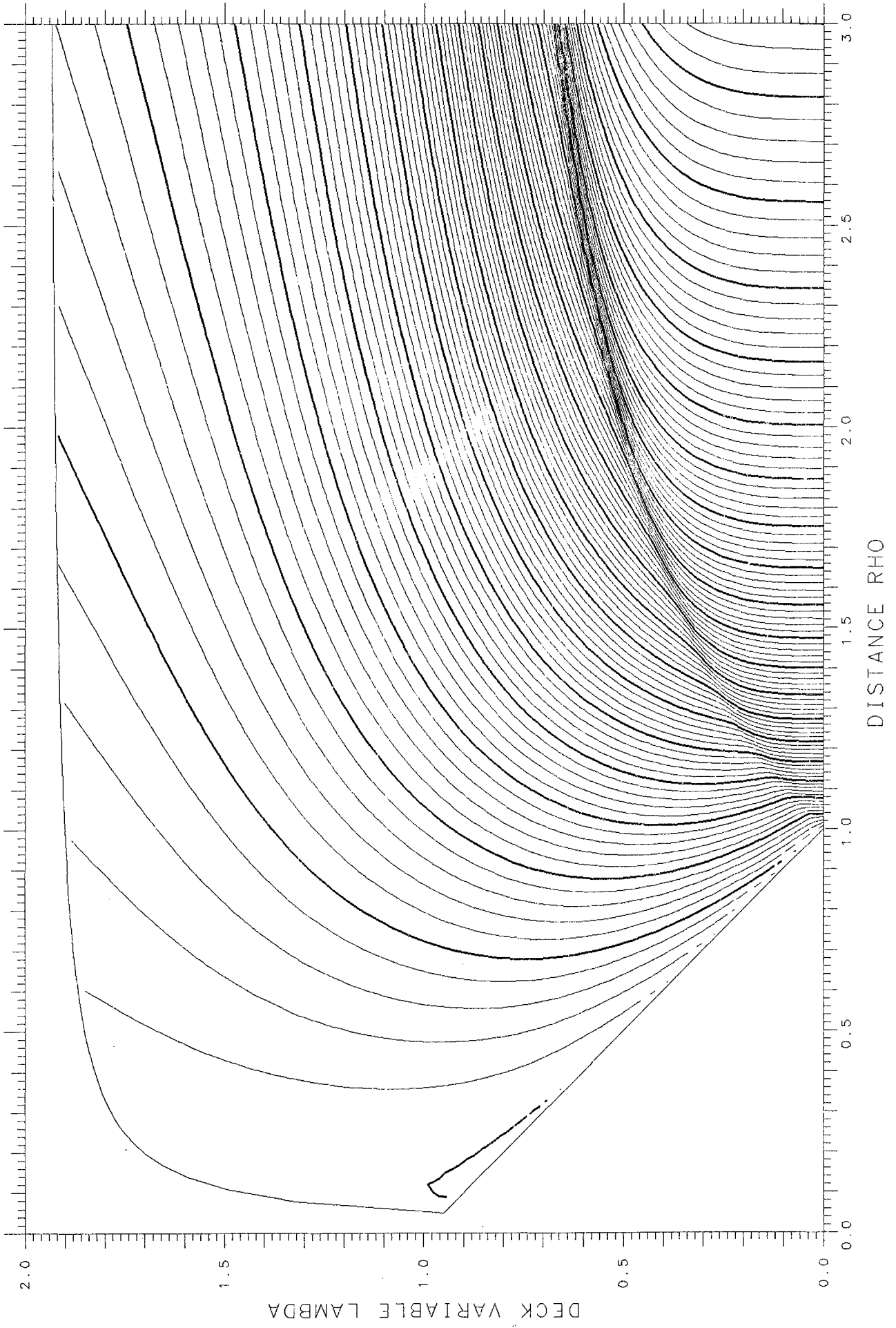

X= .100 ASYMMETRY DELTA= .175 FRACTIONAL= .7429

SPHERES .16726 TANGENT .20857 LENGTH 5.292 ENERGY 140.52 SPACING .005

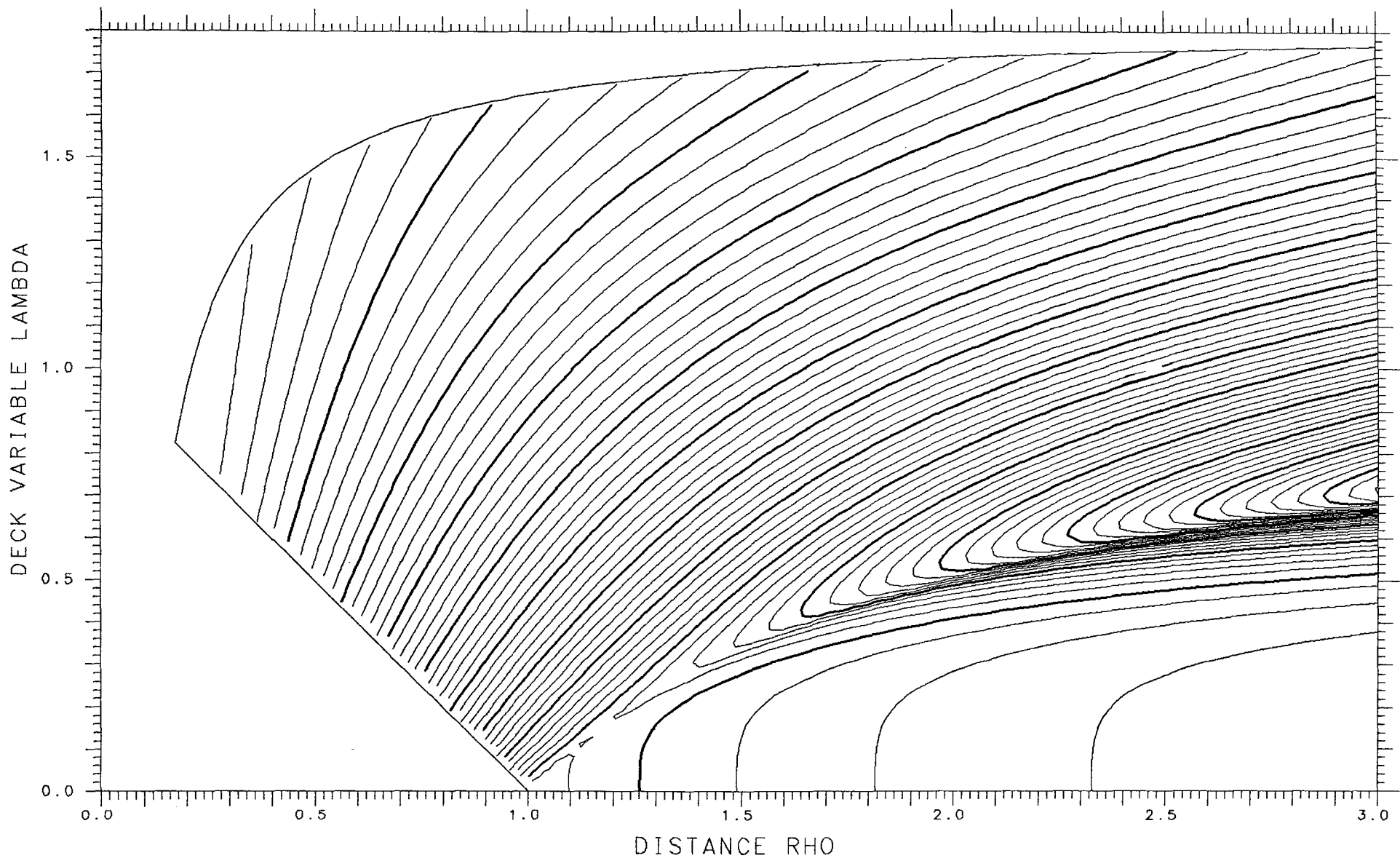

X=1.350 ASYMMETRY DELTA= .025 FRACTIONAL= .5374

SPHERES -.73467 TANGENT -.02950 LENGTH 14.939 ENERGY 914.60 SPACING .005

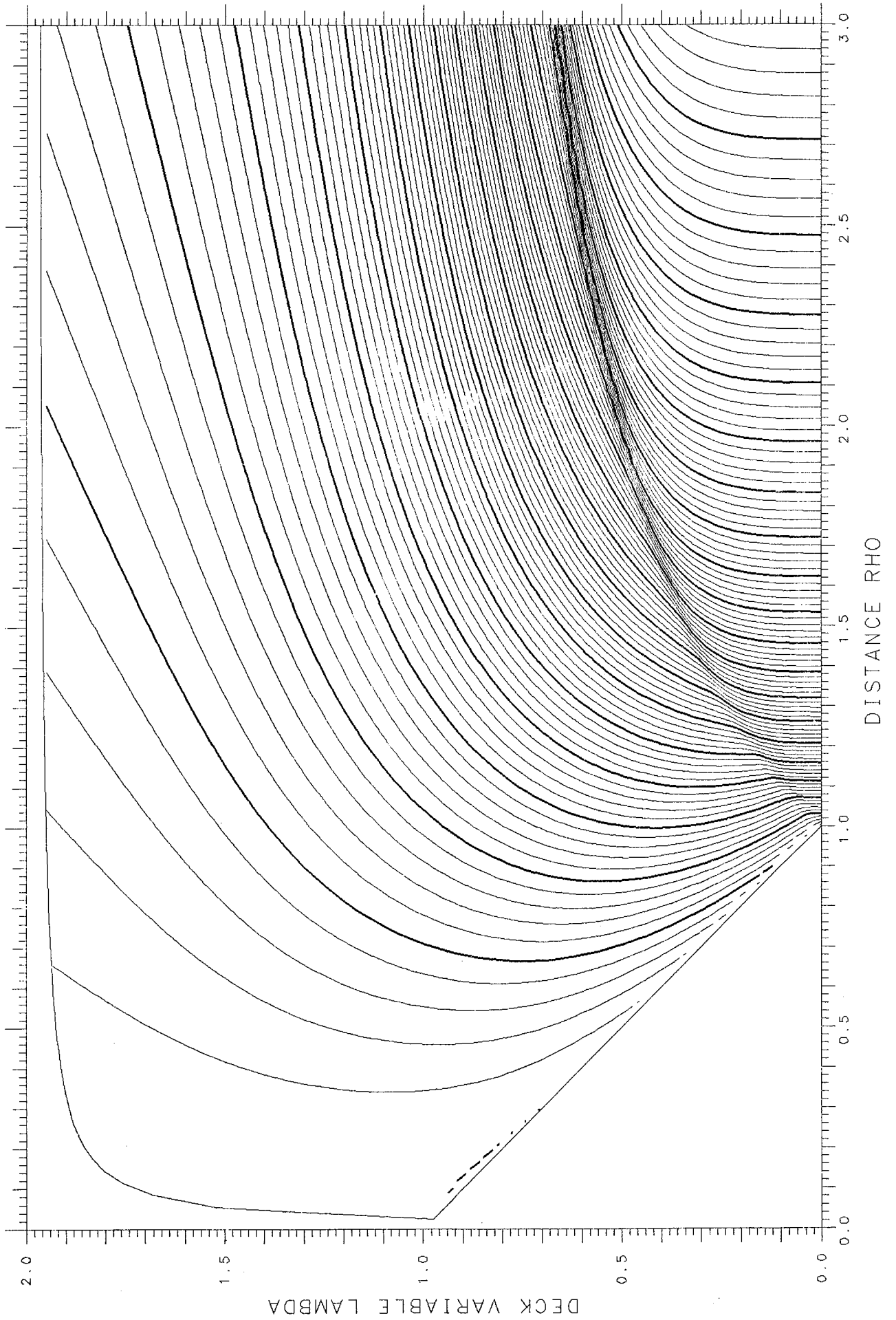

X= .100 ASYMMETRY DELTA= .200 FRACTIONAL= .7714

SPHERES .16183 TANGENT .20028 LENGTH 5.247 ENERGY 140.52 SPACING .005

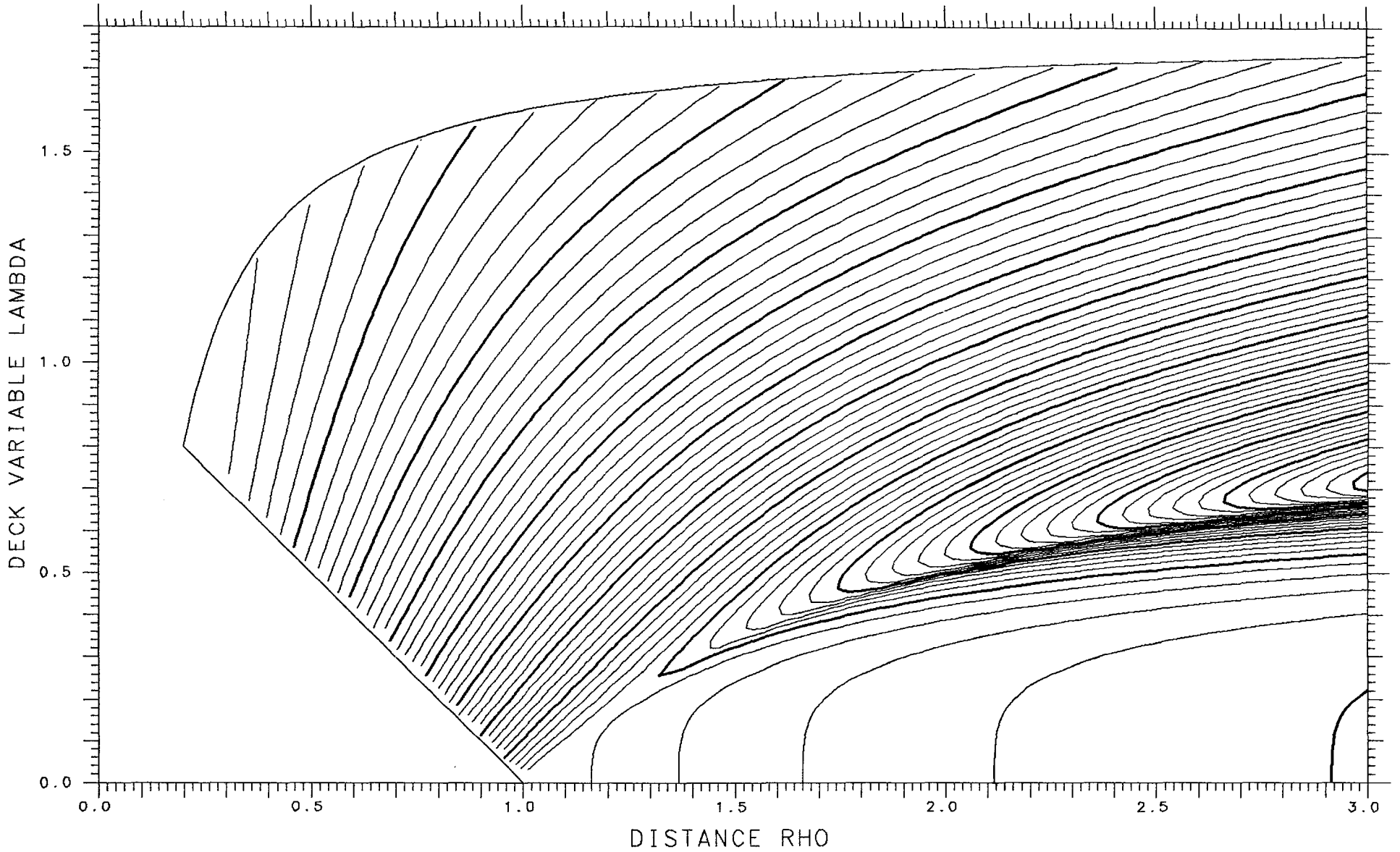

X=1.350

ASYMMETRY DELTA=0.

FRACTIONAL= .5000

SPHERES -.73919

TANGENT -.03048

LENGTH 14.948

ENERGY 914.60

SPACING .005

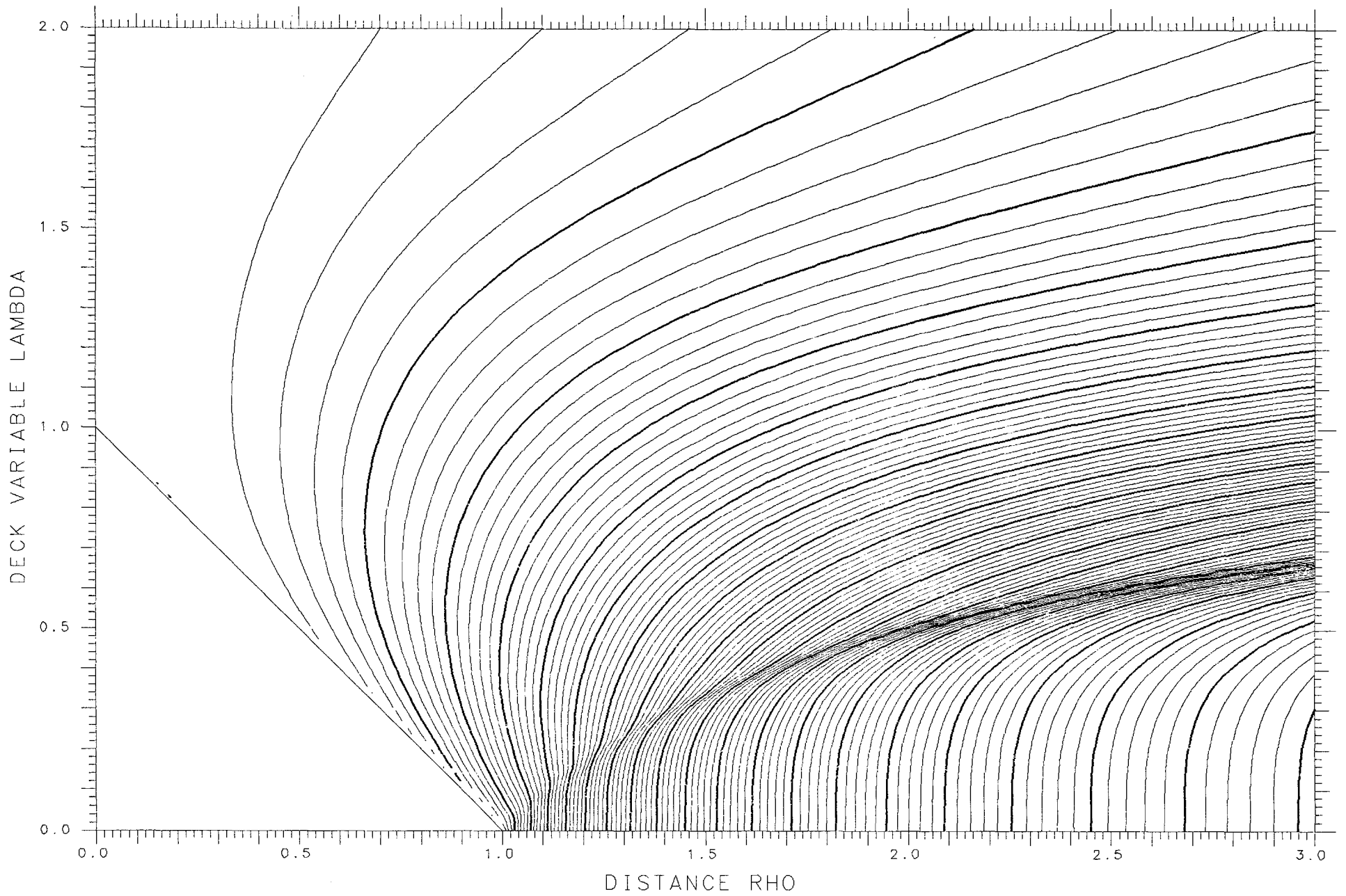

X= .100 ASYMMETRY DELTA= .225 FRACTIONAL= .7979

SPHERES .15584 TANGENT .19133 LENGTH 5.198 ENERGY 140.52 SPACING .005

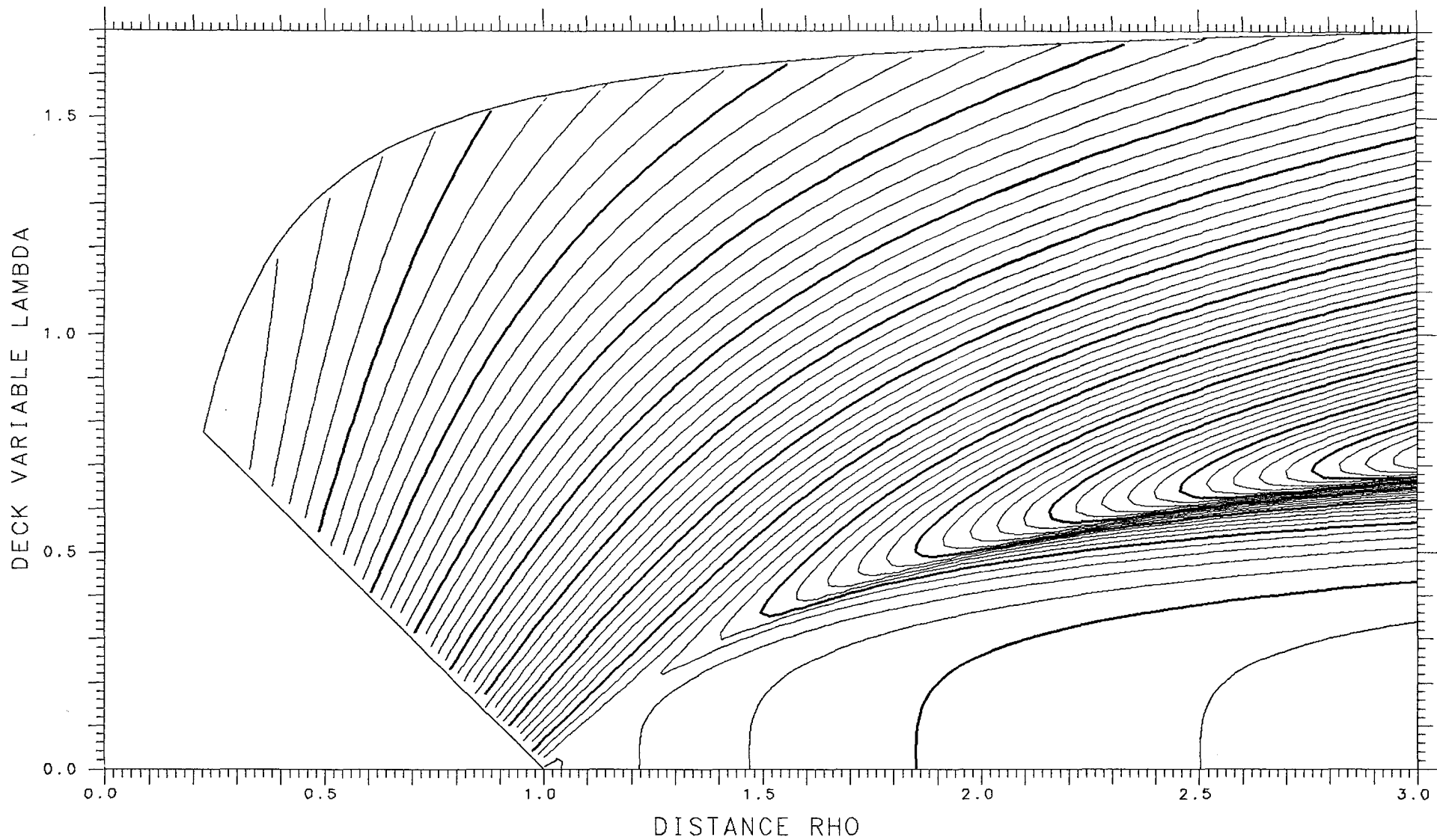

X=1.300

ASYMMETRY DELTA= .125

FRACTIONAL= .6800

SPHERES -.60242

TANGENT .00069

LENGTH 14.508

ENERGY 892.05

SPACING .005

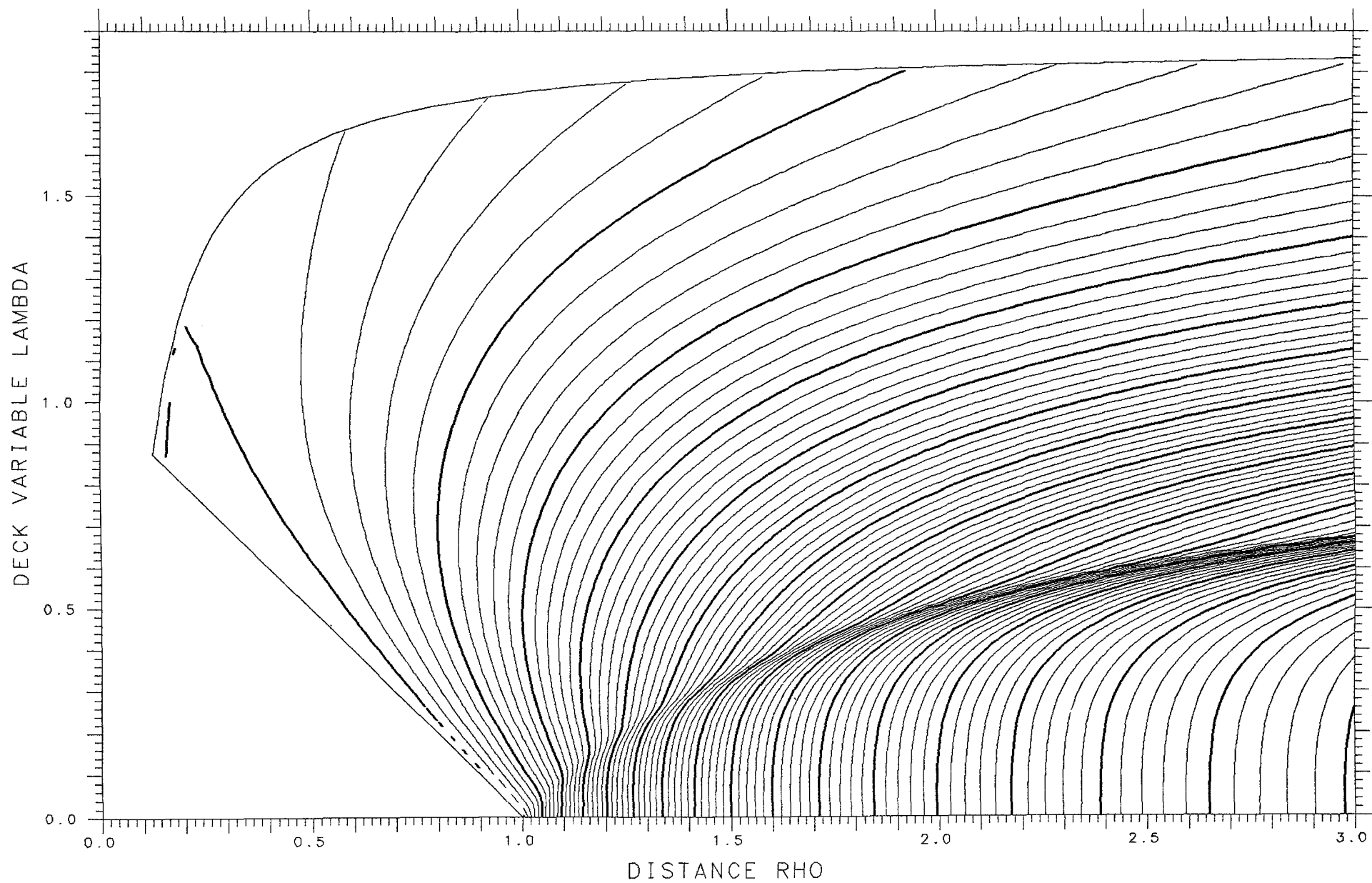

DECK VARIABLE LAMBDA

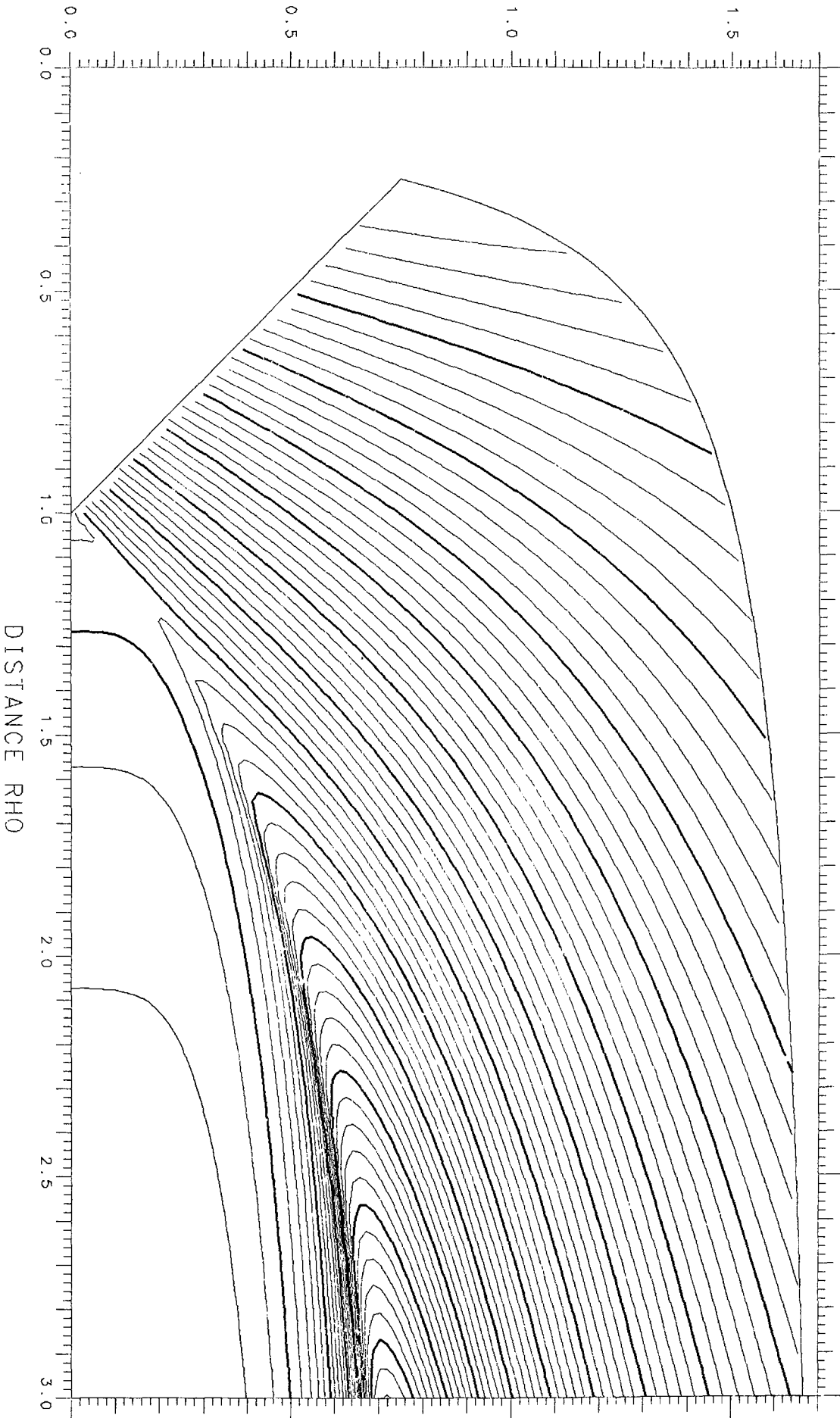

X = .100 ASYMMETRY DELTA = .250 FRACTIONAL = .8224

SPHERES .14935 TANGENT .18184 LENGTH 5.146 ENERGY 140.52 SPACING .005

X=1.300

ASYMMETRY DELTA= .100

FRACTIONAL= .6461

SPHERES -.63645

TANGENT -.00610

LENGTH 14.587

ENERGY 892.05

SPACING .005

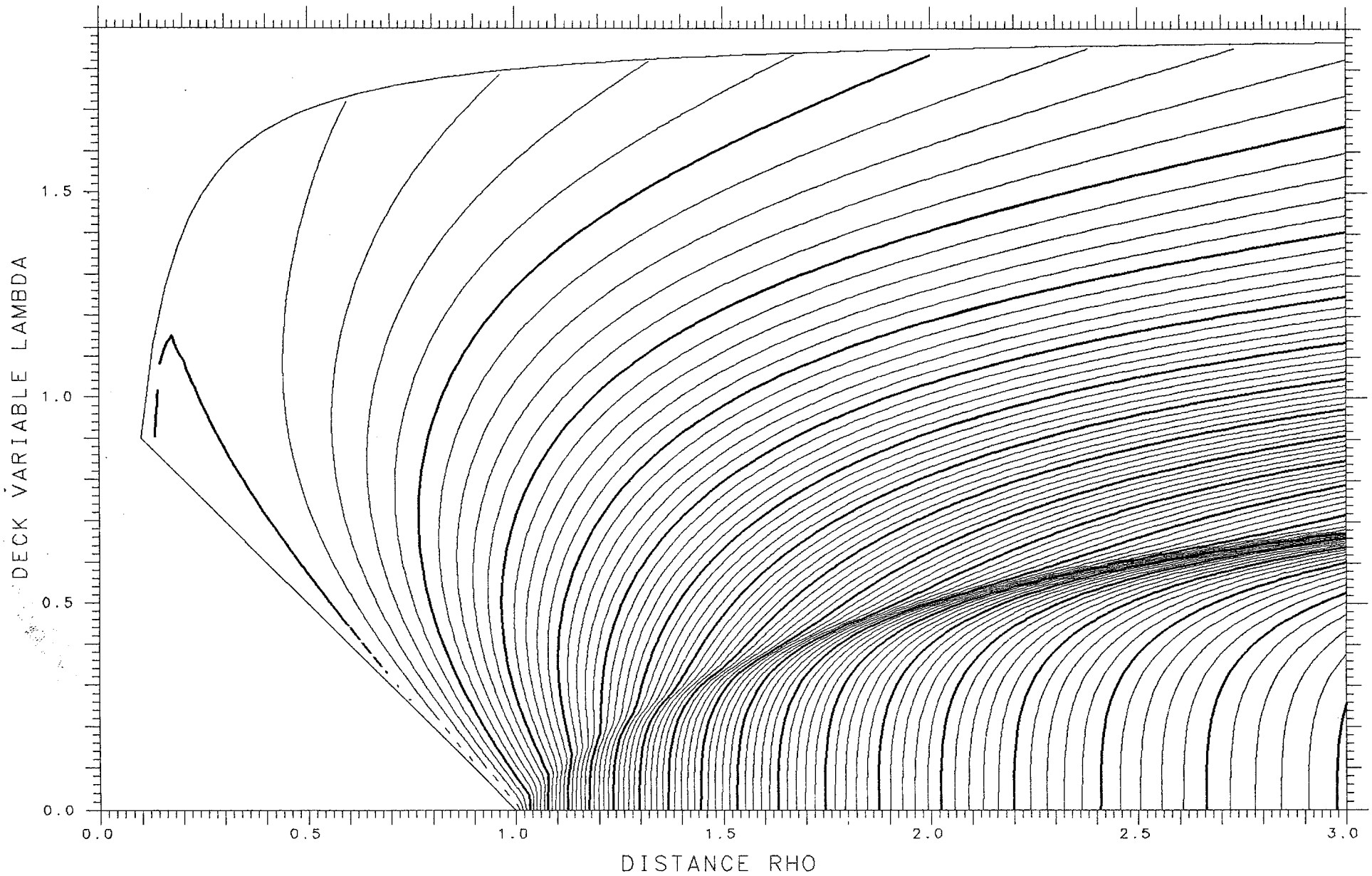

X= .100 ASYMMETRY DELTA= .275 FRACTIONAL= .8447

SPHERES .14244 TANGENT .17193 LENGTH 5.090 ENERGY 140.52 SPACING .005

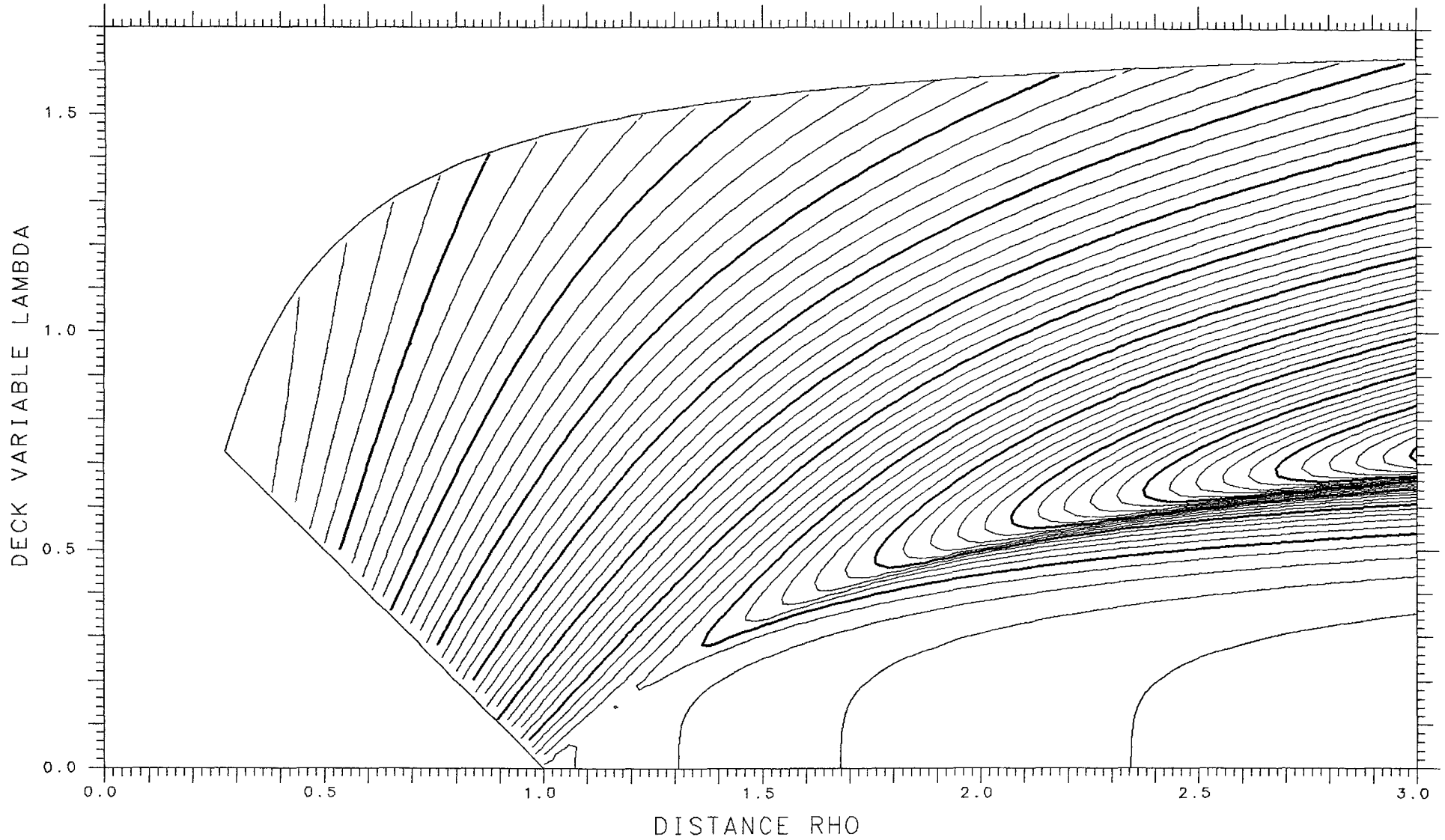

X=1.300

ASYMMETRY DELTA= .075

FRACTIONAL= .6108

SPHERES -.66435

TANGENT -.01180

LENGTH 14.650

ENERGY 892.05

SPACING .005

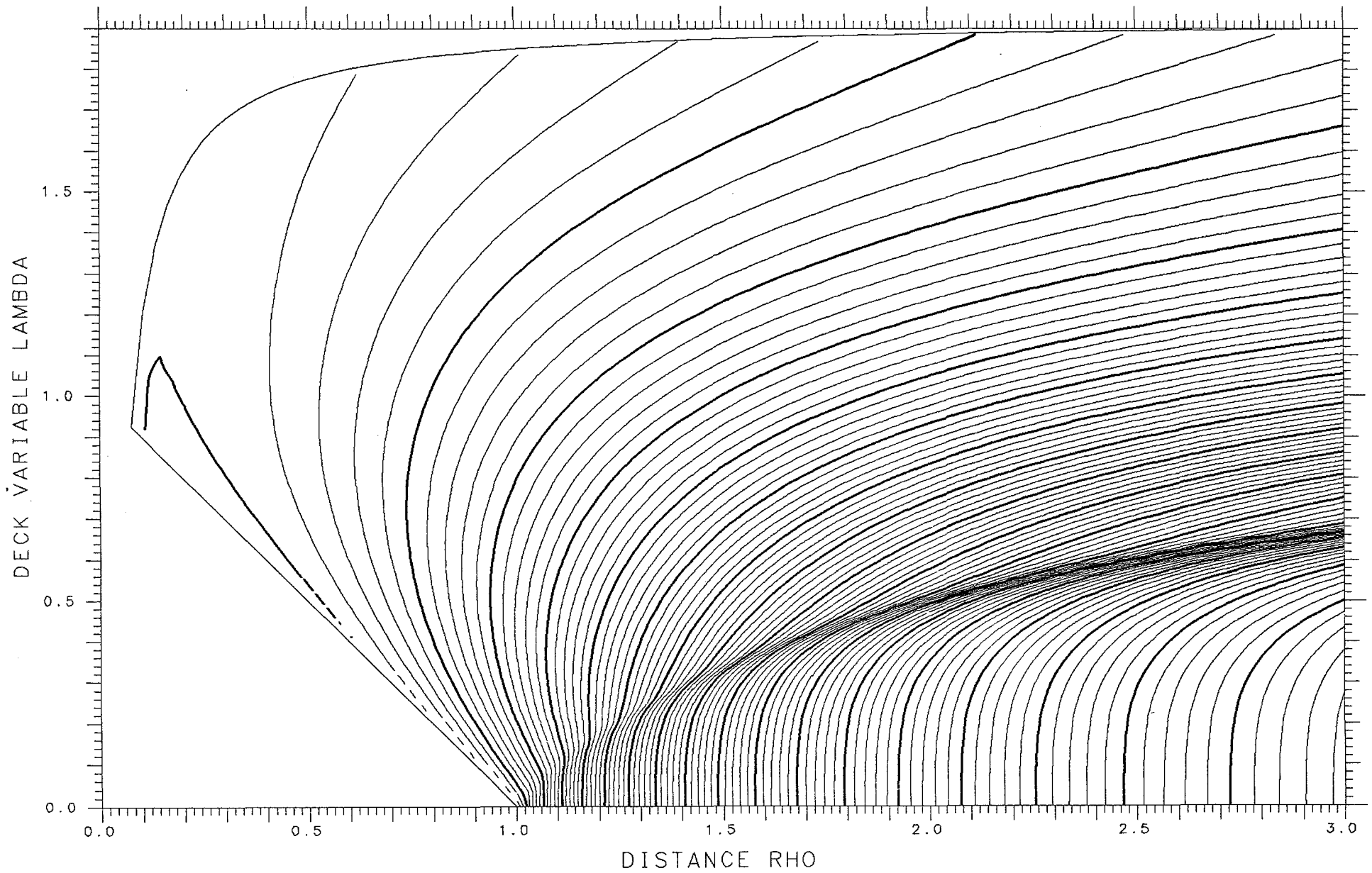

X= .150

ASYMMETRY DELTA=0.

FRACTIONAL= .5000

SPHERES .14891

TANGENT .22765

LENGTH 6.314

ENERGY 188.01

SPACING .005

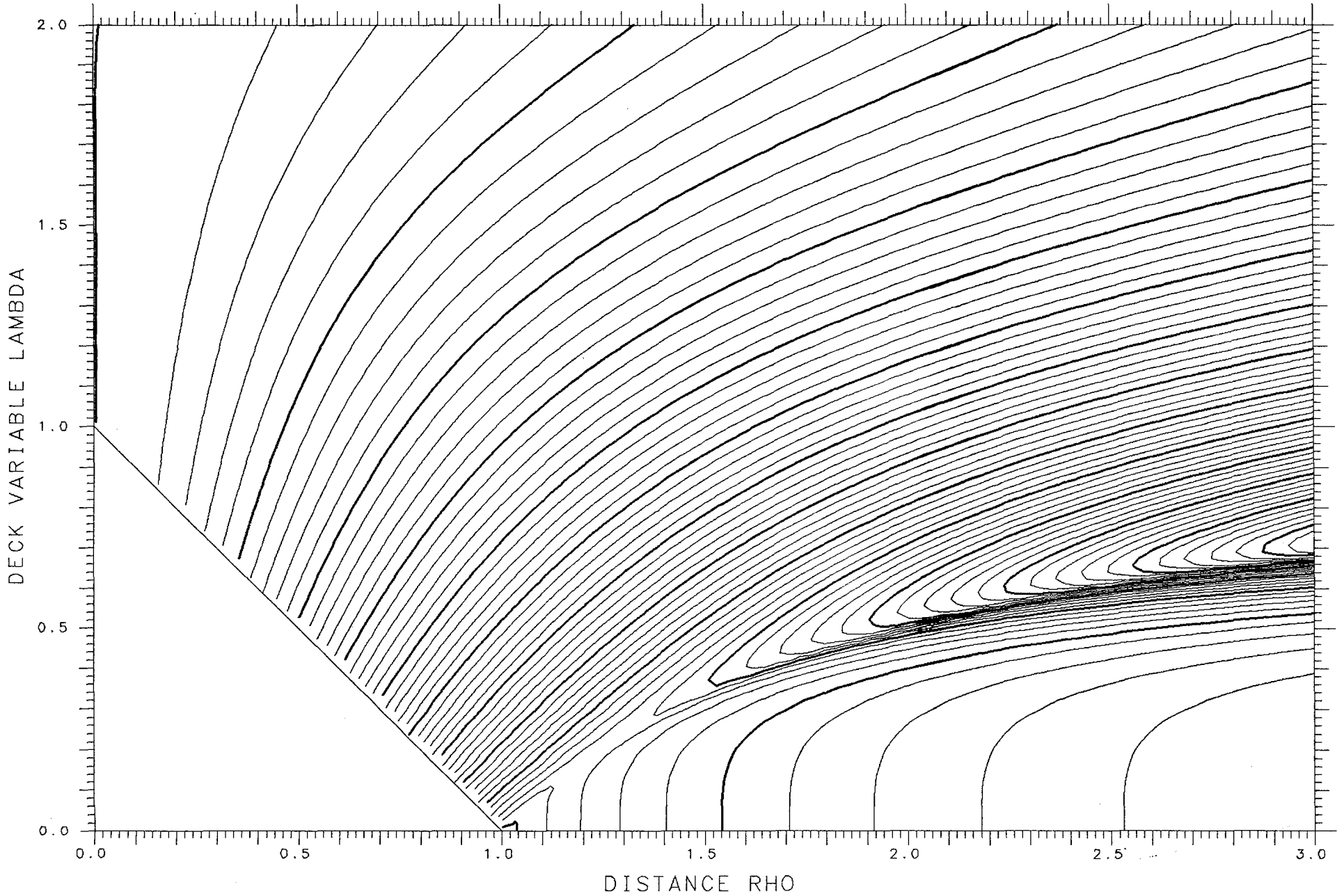

X=1.300 ASYMMETRY DELTA= .050 FRACTIONAL= .5745
SPHERES -.68509 TANGENT -.01612 LENGTH 14.695 ENERGY 892.05 SPACING .005

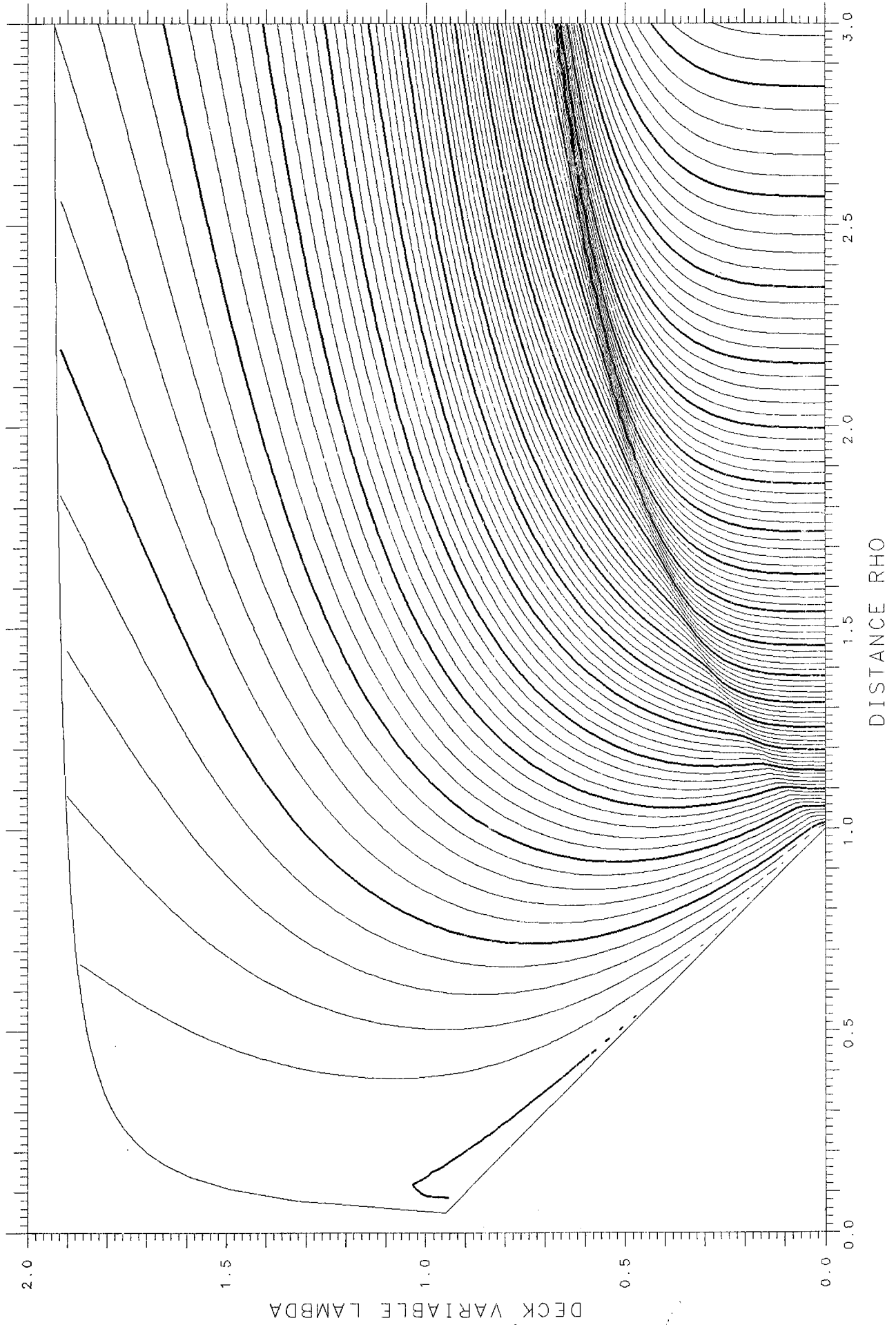

X= .150 ASYMMETRY DELTA= .025 FRACTIONAL= .5374

SPHERES .14871 TANGENT .22706 LENGTH 6.310 ENERGY 188.01 SPACING .005

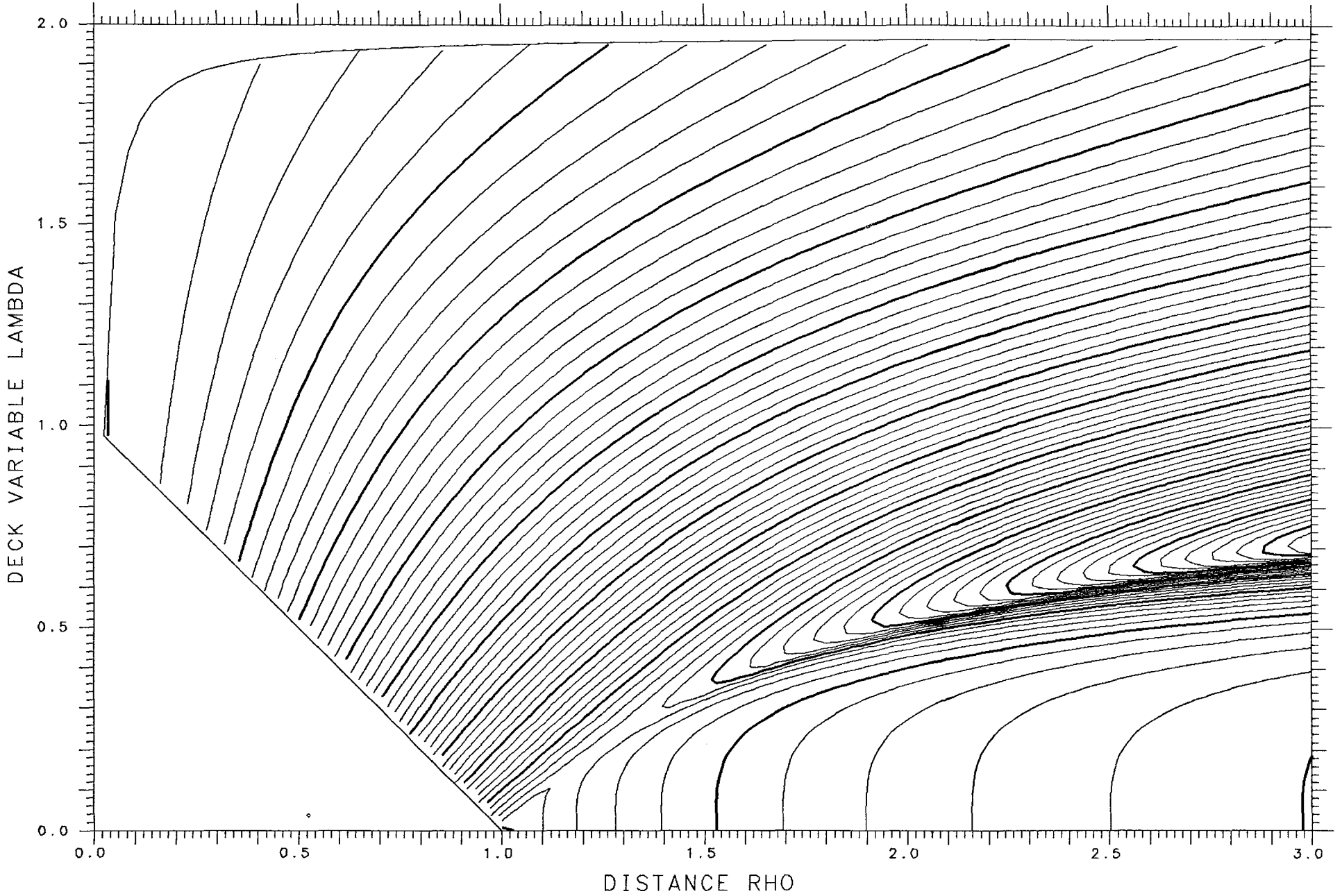

X=1.300

ASYMMETRY DELTA= .025

FRACTIONAL= .5374

SPHERES -.69787

TANGENT -.01881

LENGTH 14.722

ENERGY 892.05

SPACING .005

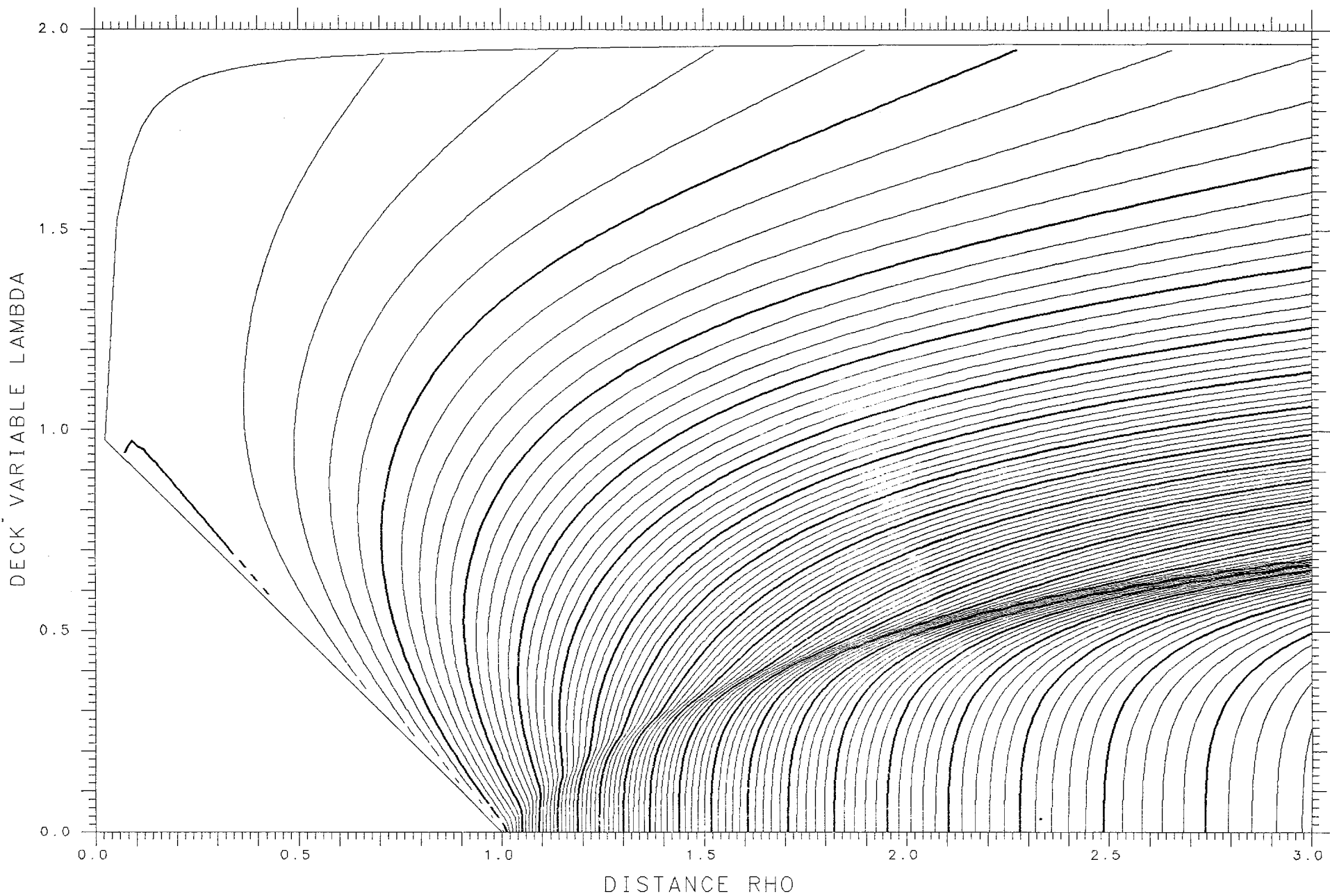

DECK VARIABLE LAMBDA

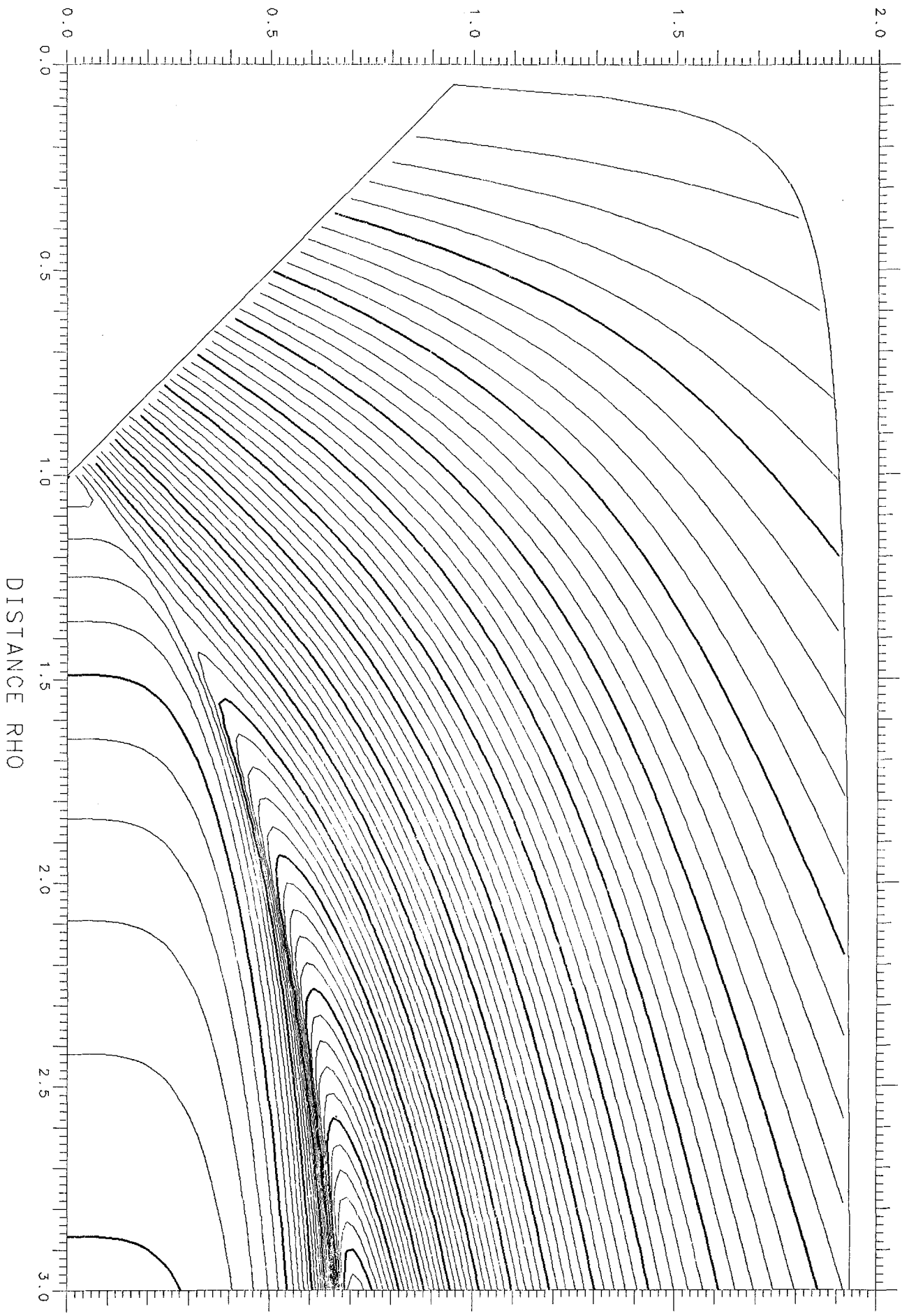

X = .150 ASYMMETRY DELTA = .050 FRACTIONAL = .5745
SPHERES .14812 TANGENT .22530 LENGTH 8.298 ENERGY 198.01 SPACING .005

X=1.300

ASYMMETRY DELTA=0.

FRACTIONAL= .5000

SPHERES -.70218

TANGENT -.01972

LENGTH 14.732

ENERGY 892.05

SPACING .005

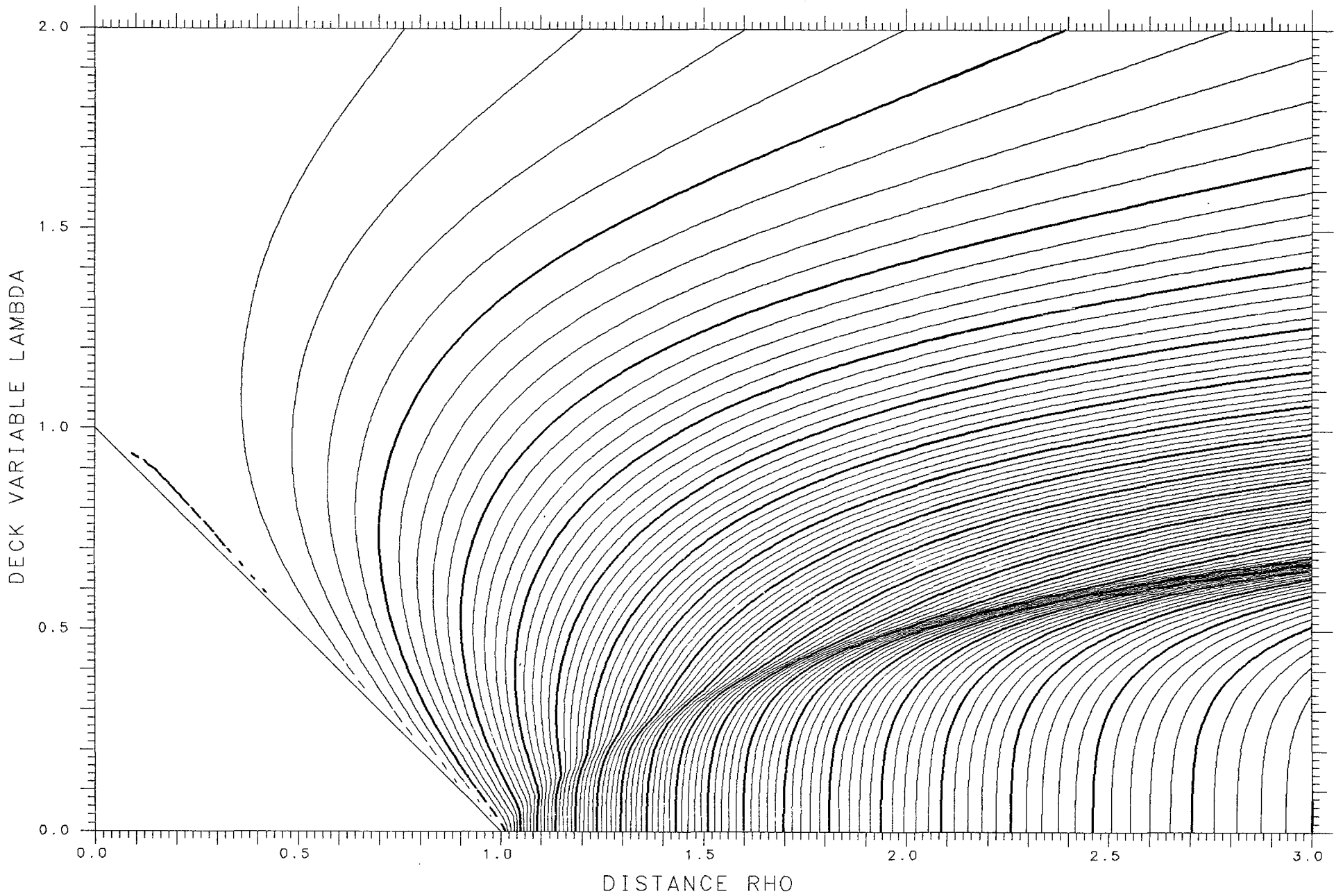

X= .150 ASYMMETRY DELTA= .075 FRACTIONAL= .6108

SPHERES .14711 TANGENT .22240 LENGTH 6.279 ENERGY 188.01 SPACING .005

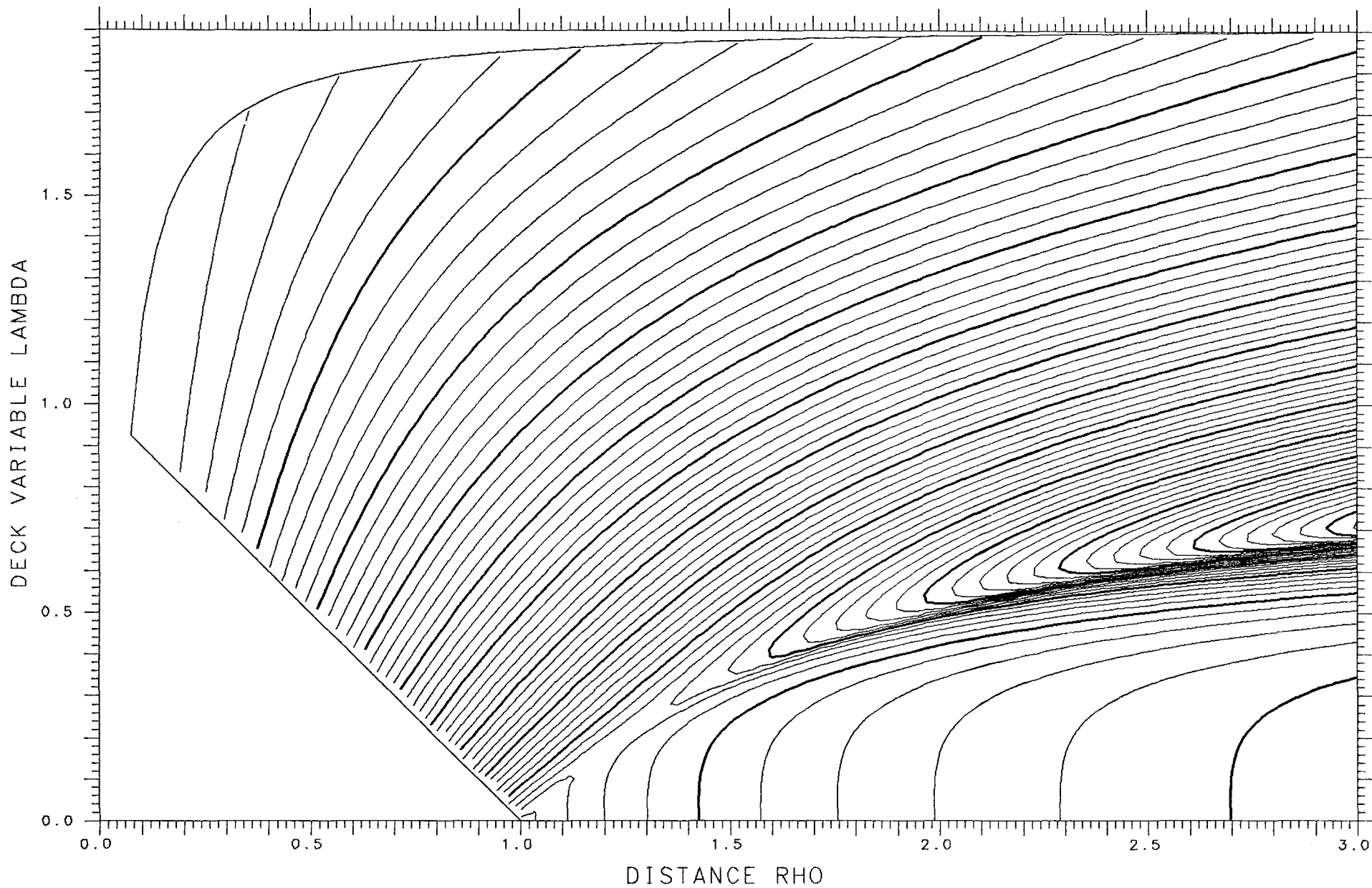

X=1.250 ASYMMETRY DELTA= .150 FRACTIONAL= .7124

SPHERES -.53280 TANGENT .01689 LENGTH 14.196 ENERGY 869.14 SPACING .005

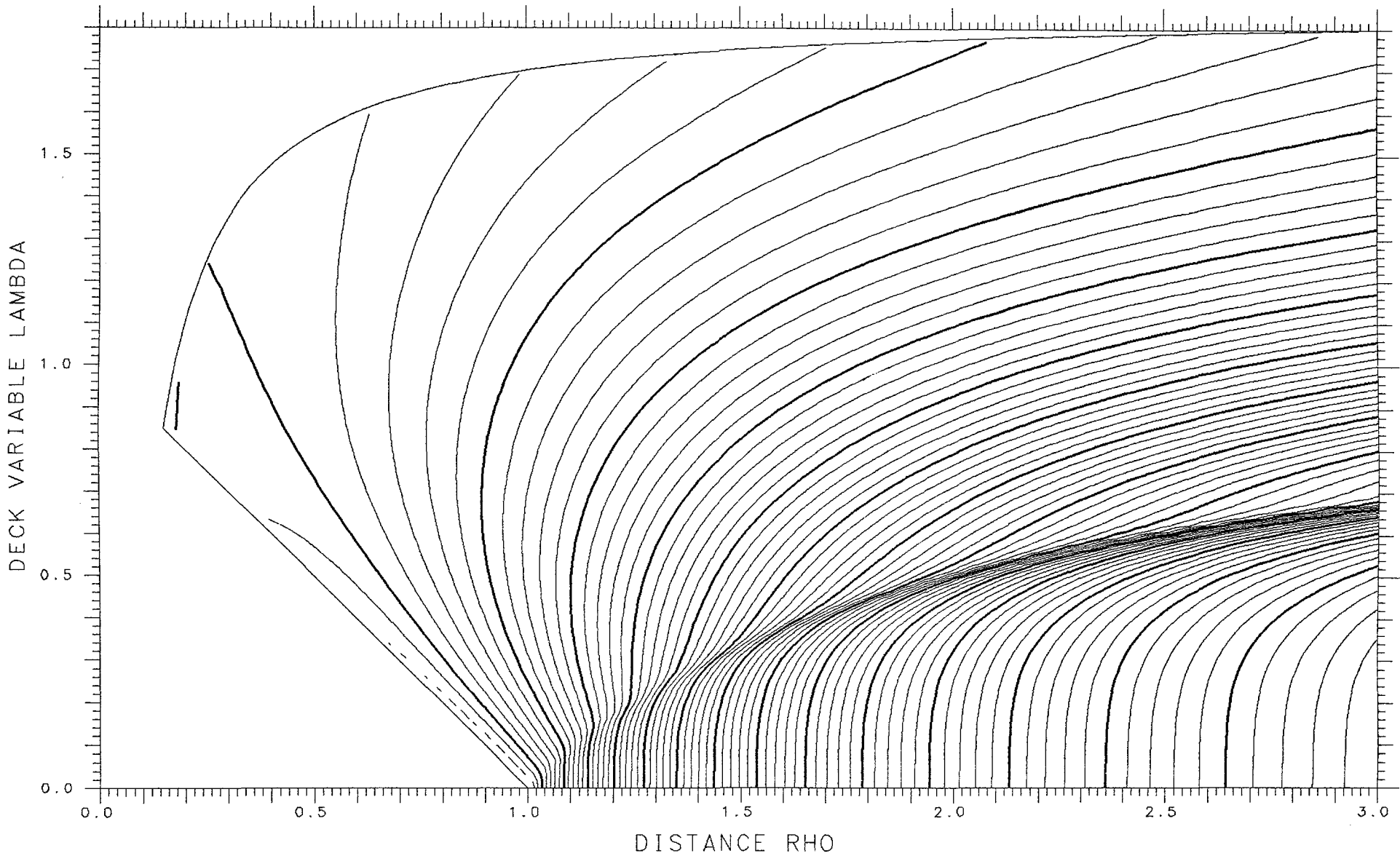

X= .150 ASYMMETRY DELTA= .100 FRACTIONAL= .6461

SPHERES .14567 TANGENT .21841 LENGTH 6.252 ENERGY 188.01 SPACING .005

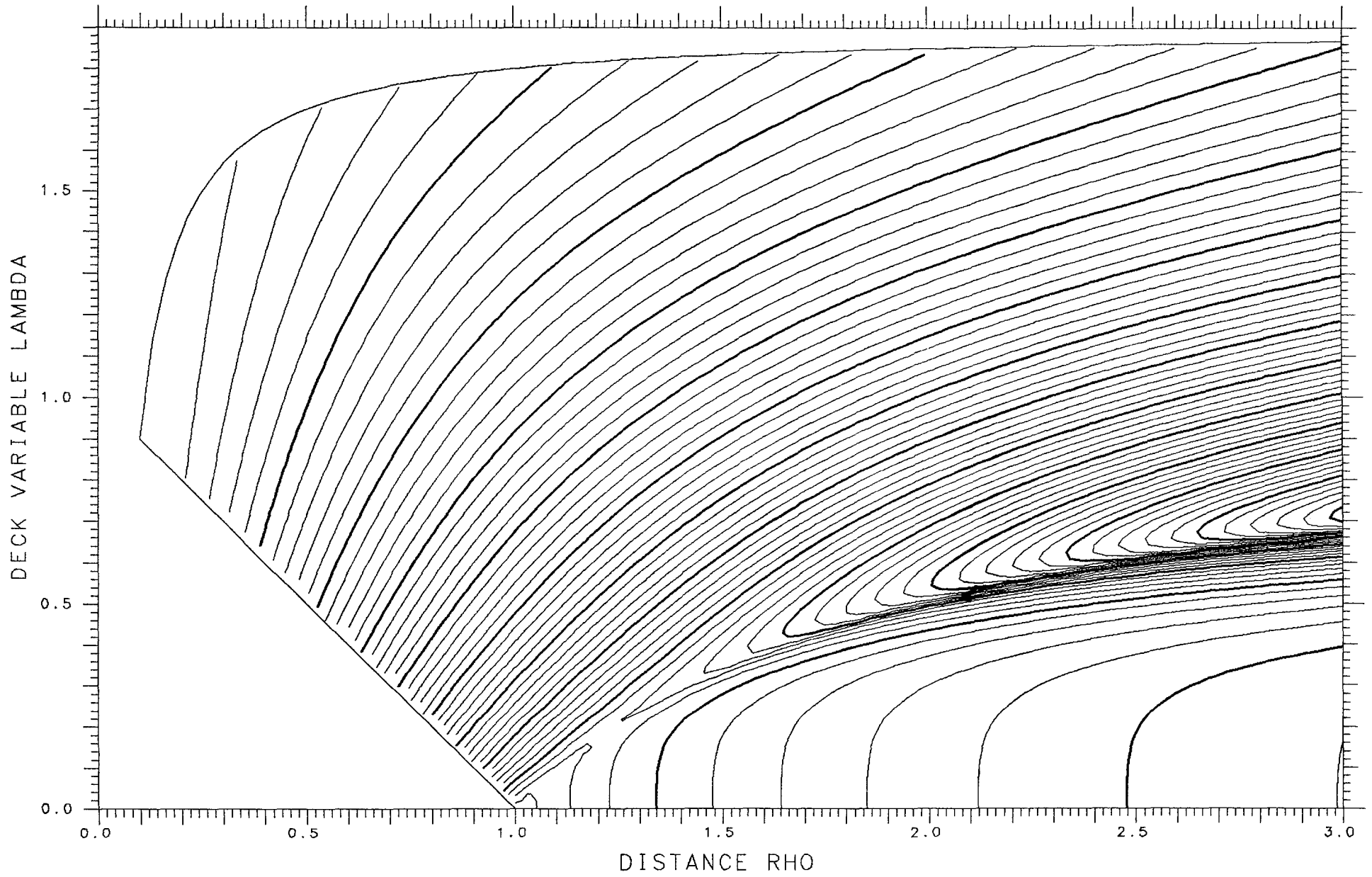

X=1.250

ASYMMETRY DELTA= .125

FRACTIONAL= .6800

SPHERES -.56998

TANGENT .00994

LENGTH 14.289

ENERGY 869.14

SPACING .005

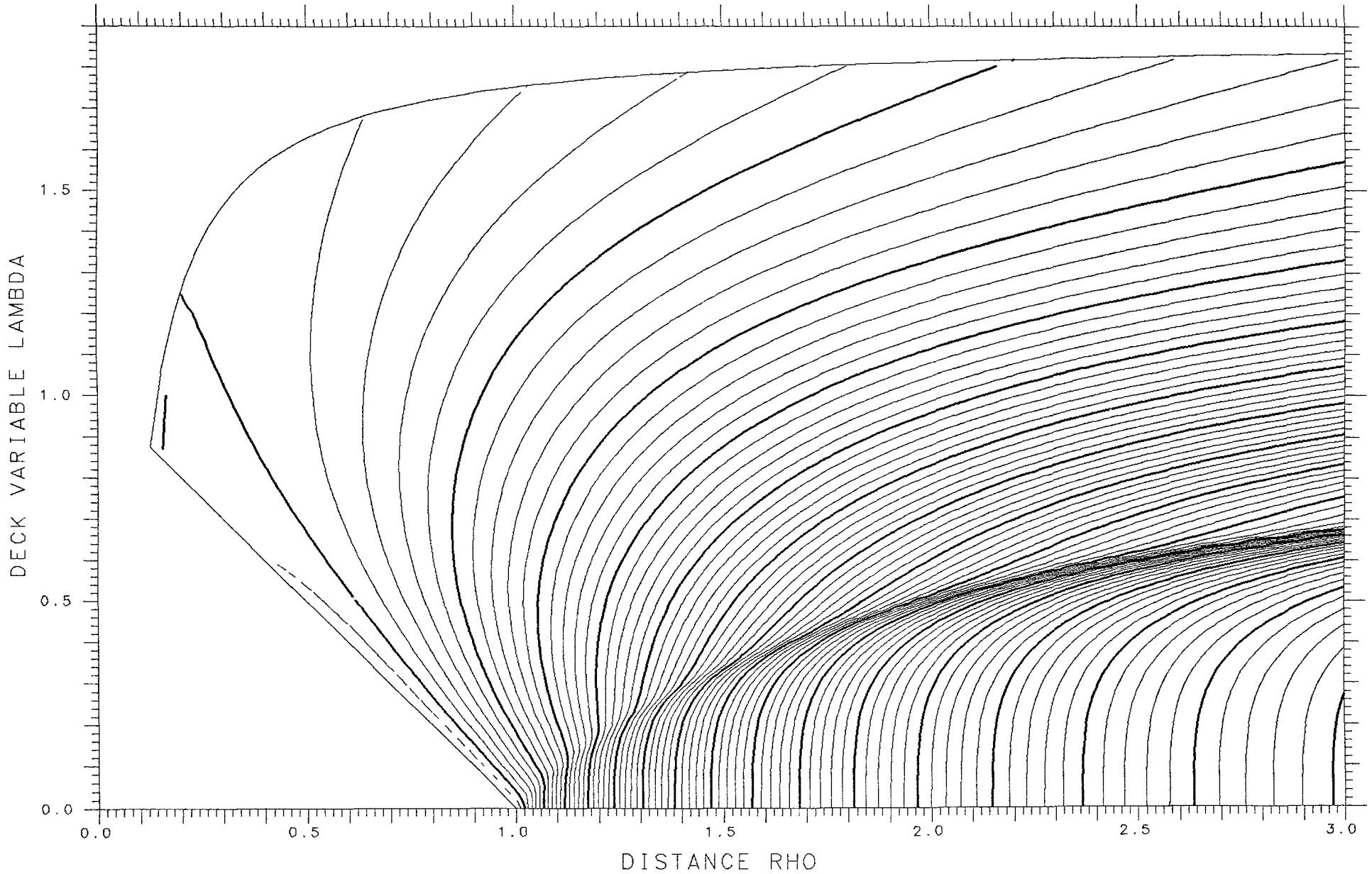

X= .150 ASYMMETRY DELTA= .125 FRACTIONAL= .6800

SPHERES .14379 TANGENT .21338 LENGTH 6.218 ENERGY 188.01 SPACING .005

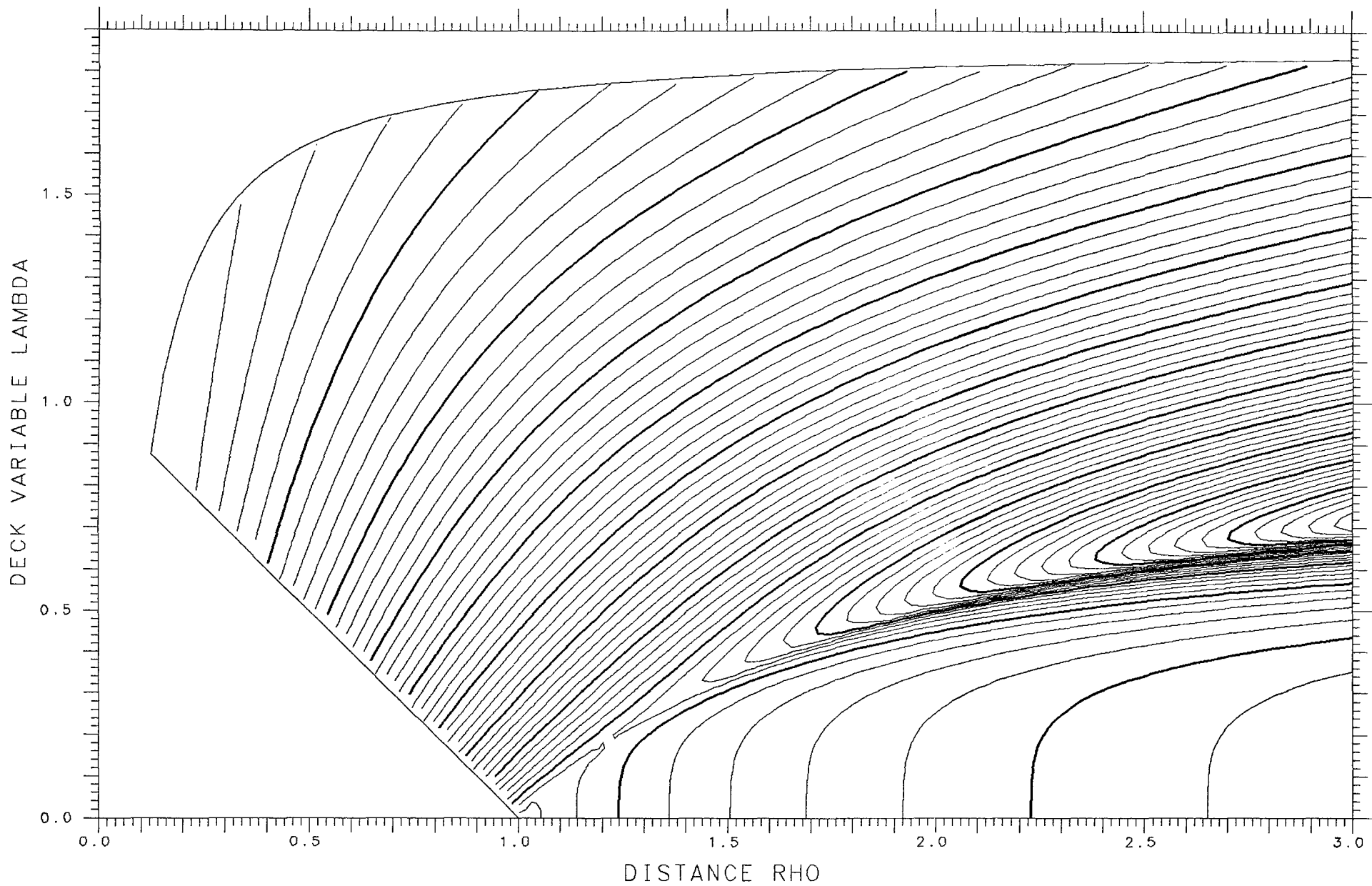

X=1.250

ASYMMETRY DELTA= .100

FRACTIONAL= .6461

SPHERES -.60245

TANGENT .00366

LENGTH 14.367

ENERGY 869.14

SPACING .005

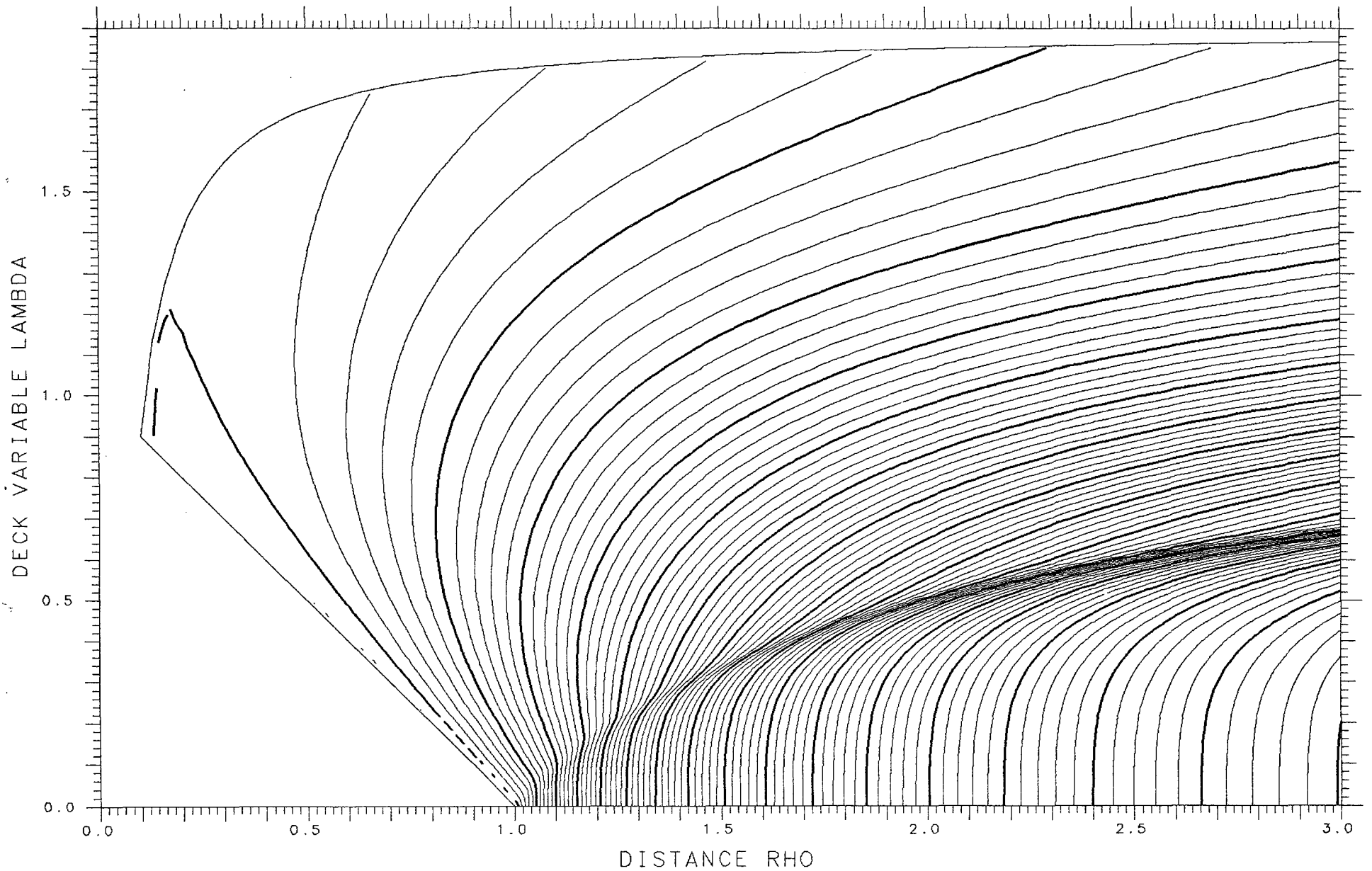

X= .150 ASYMMETRY DELTA= .150 FRACTIONAL= .7124

SPHERES .14143 TANGENT .20740 LENGTH 6.178 ENERGY 188.01 SPACING .005

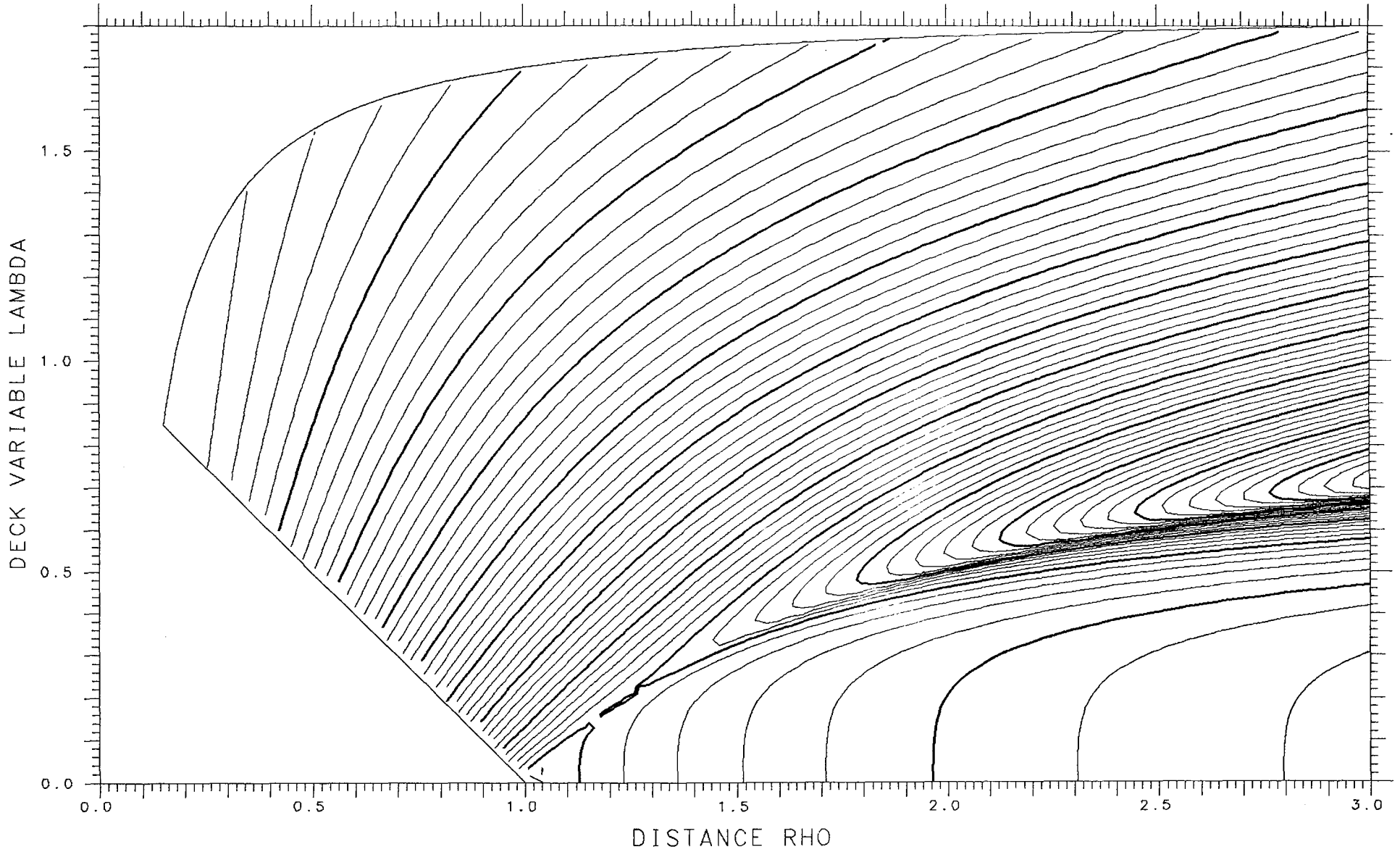

X=1.250

ASYMMETRY DELTA= .075

FRACTIONAL= .6108

SPHERES -.62907

TANGENT -.00162

LENGTH 14.428

ENERGY 869.14

SPACING .005

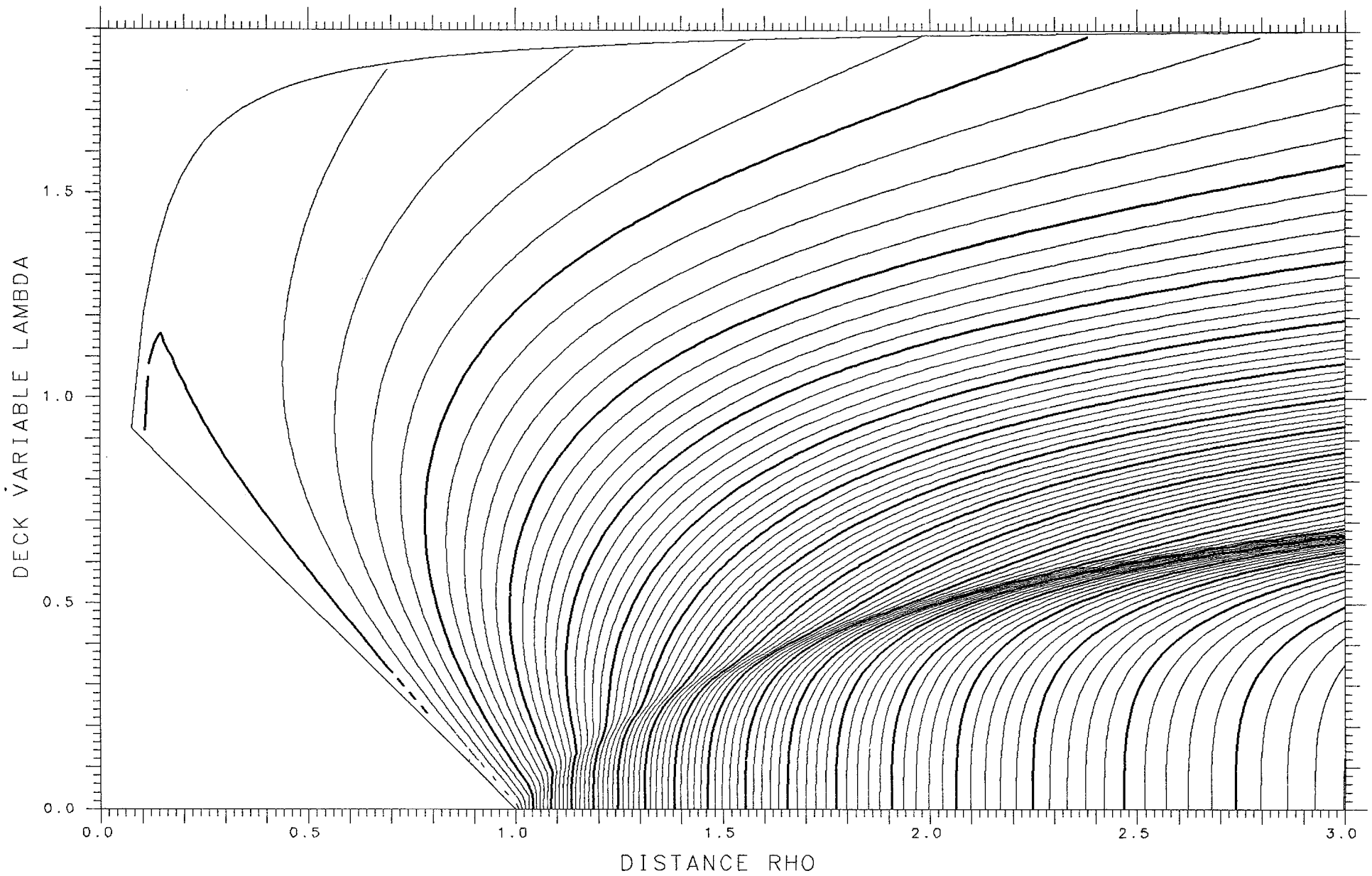

X= .150 ASYMMETRY DELTA= .175 FRACTIONAL= .7429

SPHERES .13859 TANGENT .20055 LENGTH 6.131 ENERGY 188.01 SPACING .005

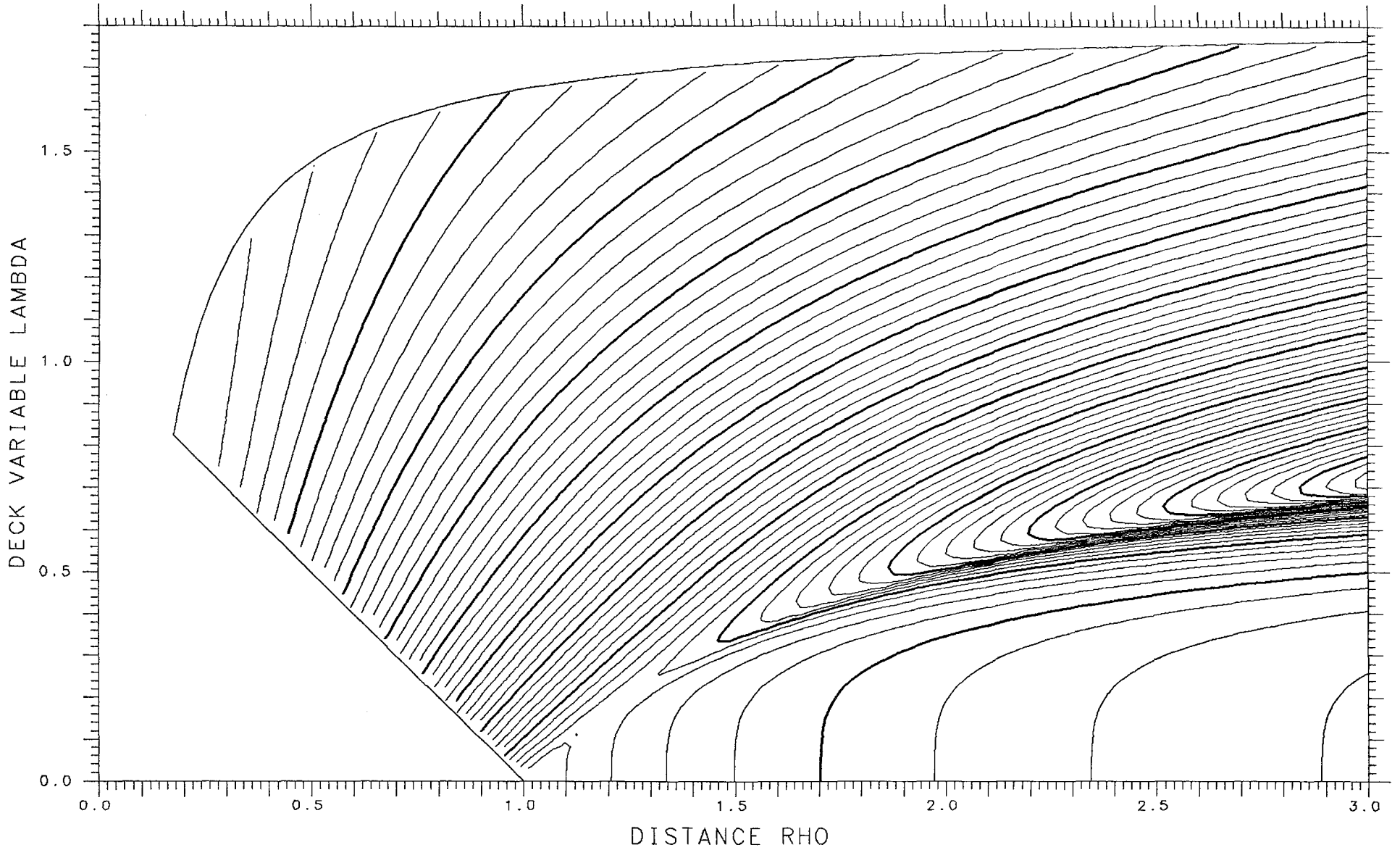

X=1.250

ASYMMETRY DELTA= .050

FRACTIONAL= .5745

SPHERES -.64886

TANGENT -.00562

LENGTH 14.473

ENERGY 869.14

SPACING .005

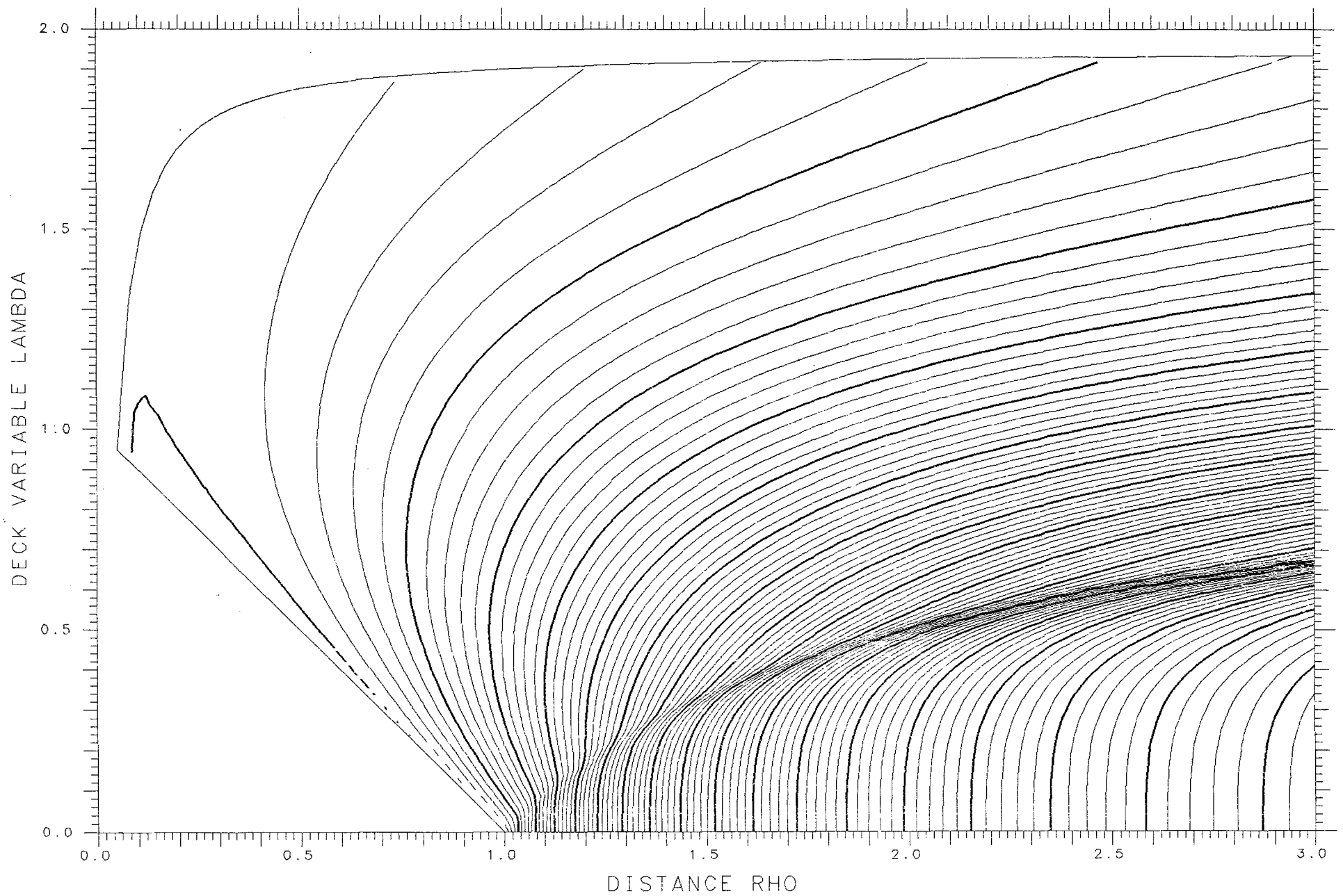

X= .150 ASYMMETRY DELTA= .200 FRACTIONAL= .7714

SPHERES .13526 TANGENT .19294 LENGTH 6.080 ENERGY 188.01 SPACING .005

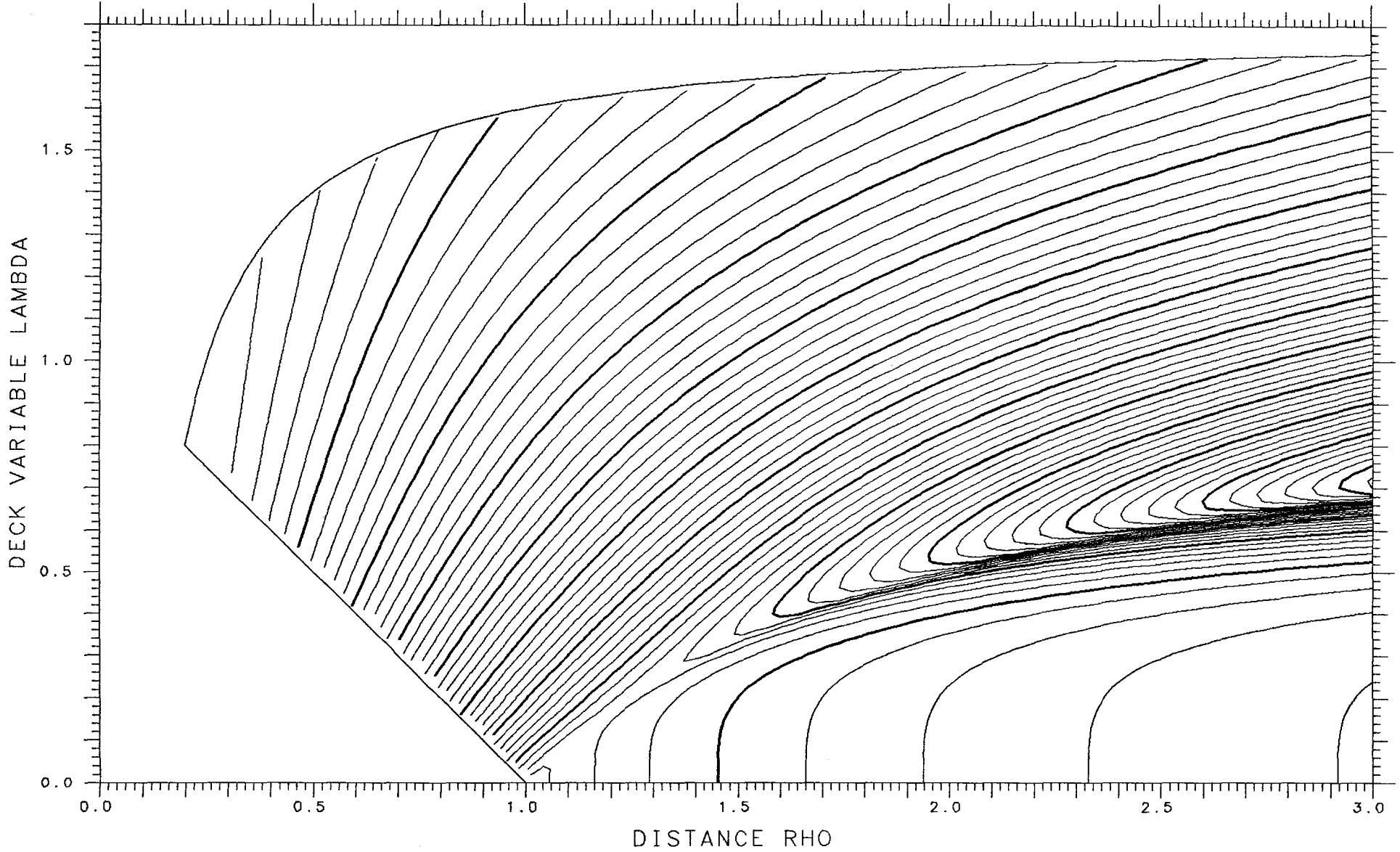

X=1.250

ASYMMETRY DELTA= .025

FRACTIONAL= .5374

SPHERES -.66106

TANGENT -.00812

LENGTH 14.500

ENERGY 869.14

SPACING .005

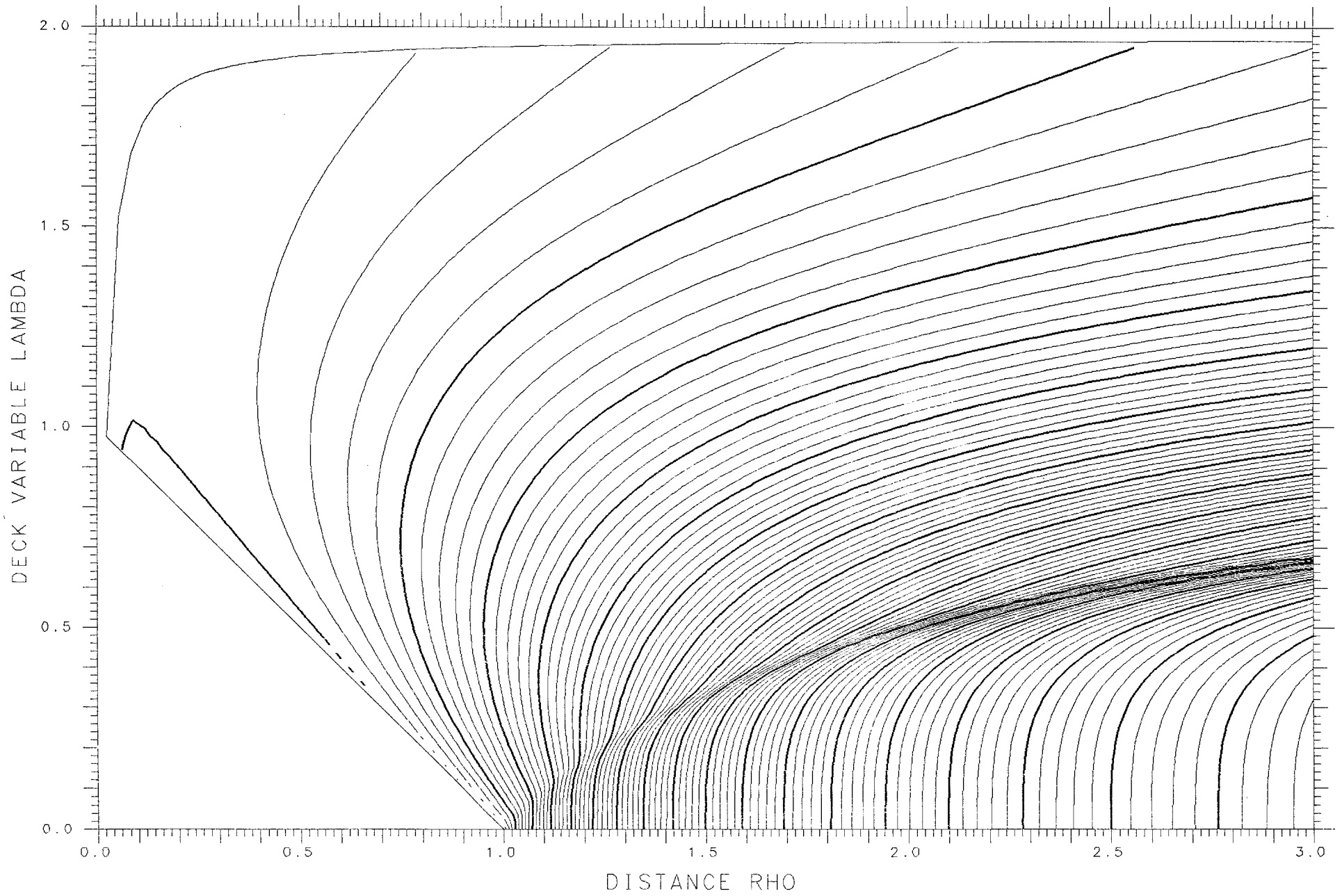

X= .150 ASYMMETRY DELTA= .225 FRACTIONAL= .7979

SPHERES .13144 TANGENT .18468 LENGTH 6.023 ENERGY 188.01 SPACING .005

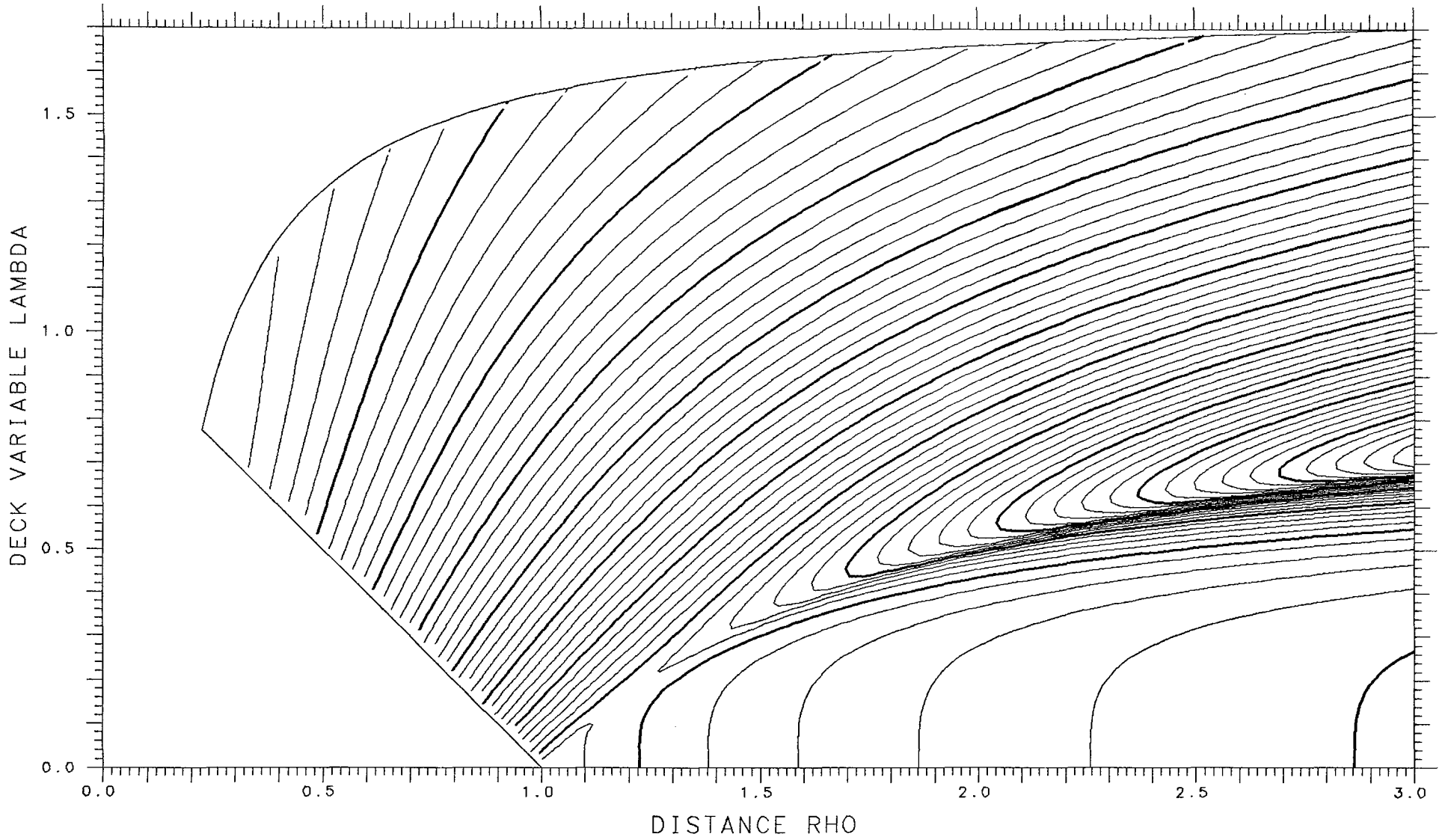

X=1.250

ASYMMETRY DELTA=0.

FRACTIONAL= .5000

SPHERES -.66518

TANGENT -.00897

LENGTH 14.509

ENERGY 869.14

SPACING .005

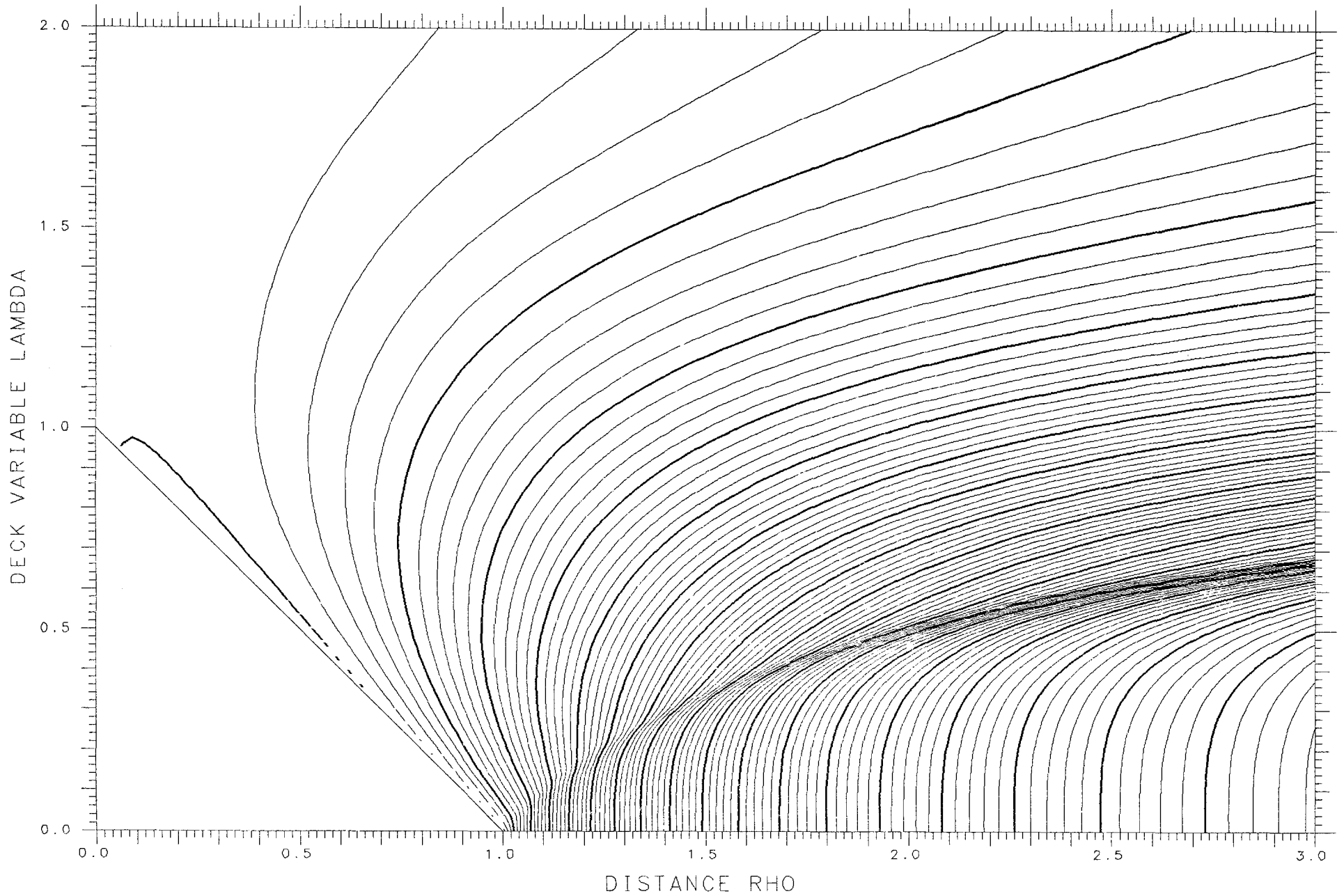

DECK VARIABLE LAMBDA

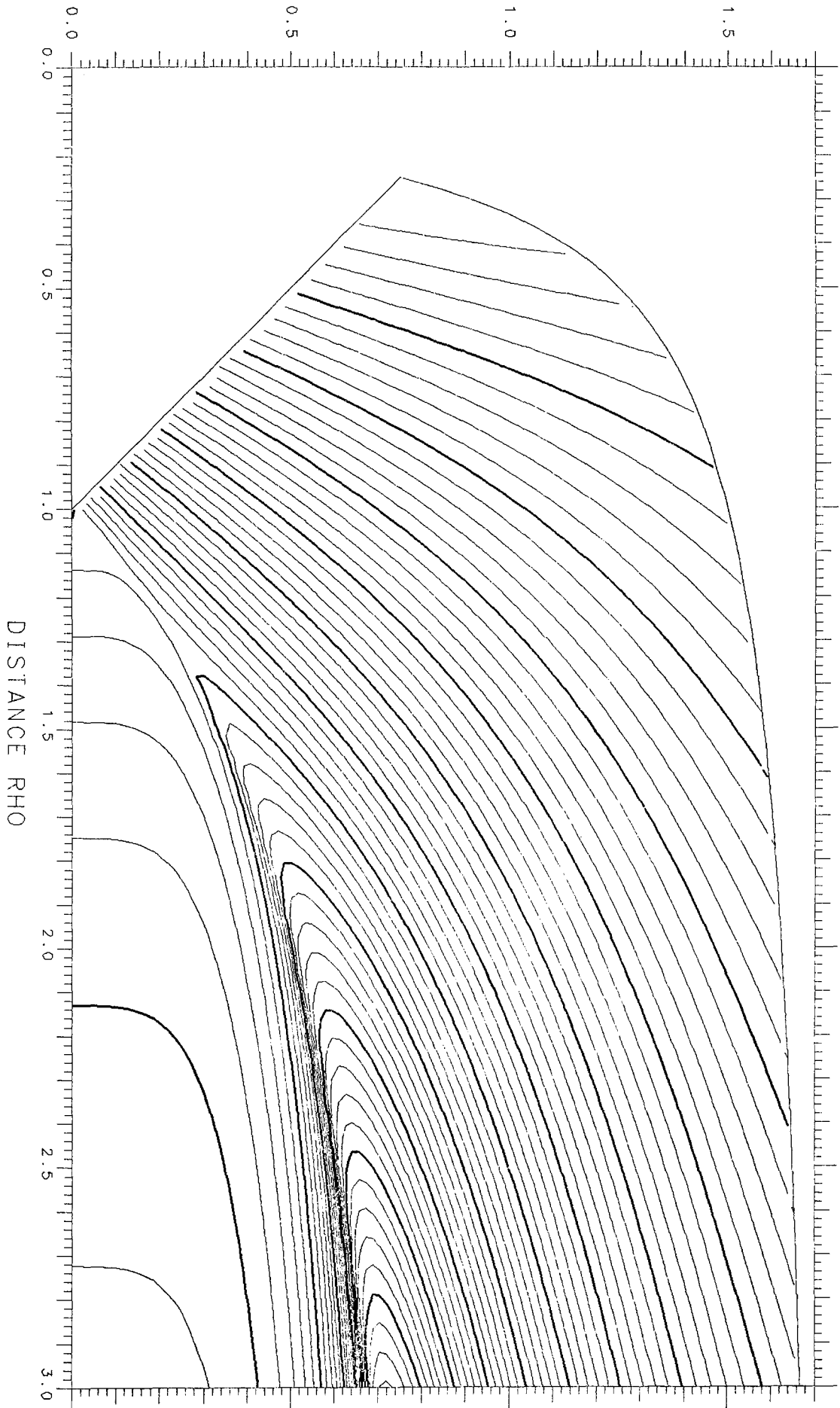

X = .150 ASYMMETRY DELTA = .250 FRACTIONAL = .8224
SPHERES .12715 TANGENT .17588 LENGTH 5.962 ENERGY 188.01 SPACING .005

X=1.200

ASYMMETRY DELTA= .175

FRACTIONAL= .7429

SPHERES -.46347

TANGENT .03217

LENGTH 13.867

ENERGY 845.81

SPACING .005

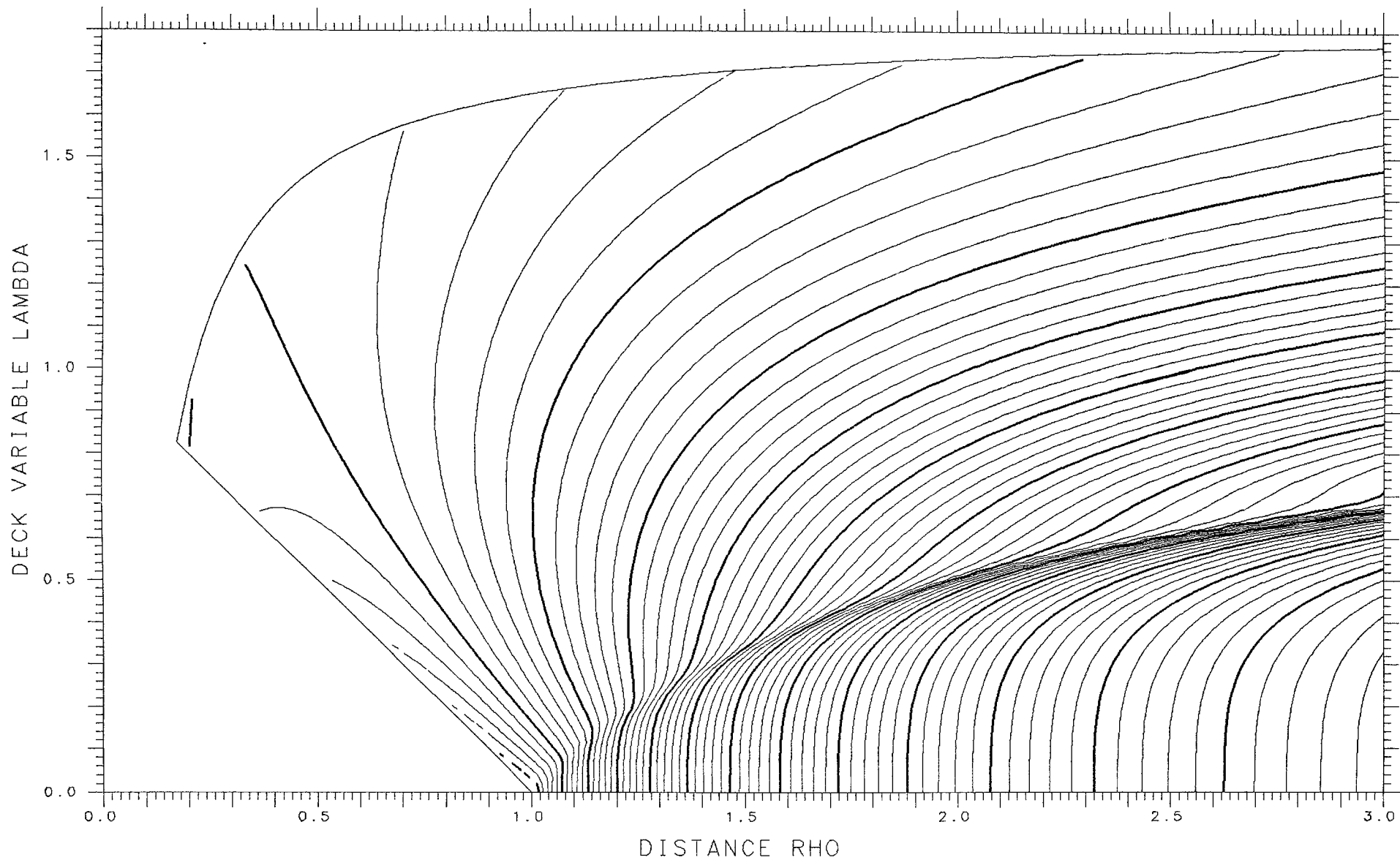

X= .150 ASYMMETRY DELTA= .275 FRACTIONAL= .8447

SPHERES .12241 TANGENT .16665 LENGTH 5.898 ENERGY 188.01 SPACING .005

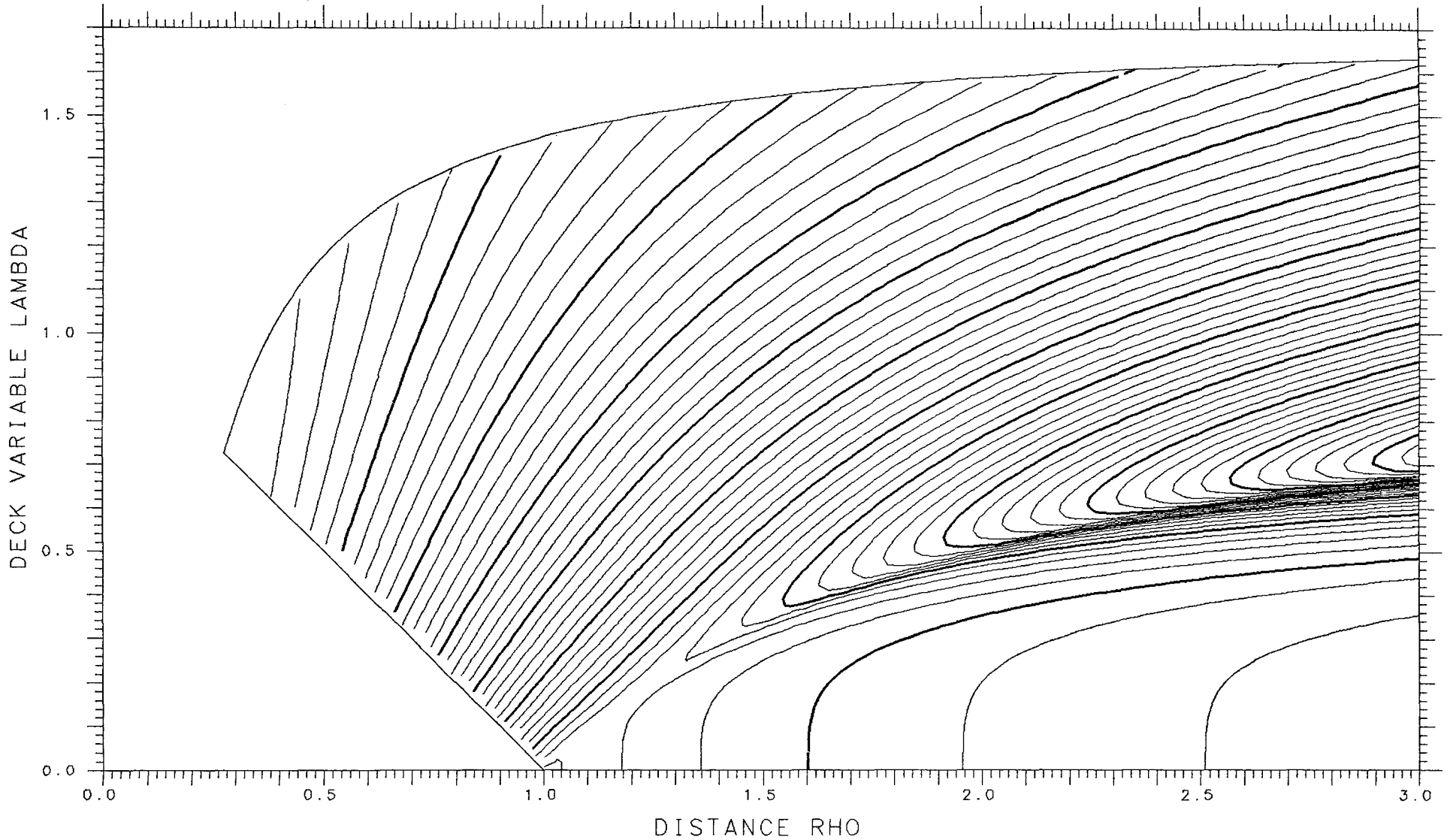

X=1.200

ASYMMETRY DELTA= .150

FRACTIONAL= .7124

SPHERES -.50215

TANGENT .02555

LENGTH 13.972

ENERGY 845.81

SPACING .005

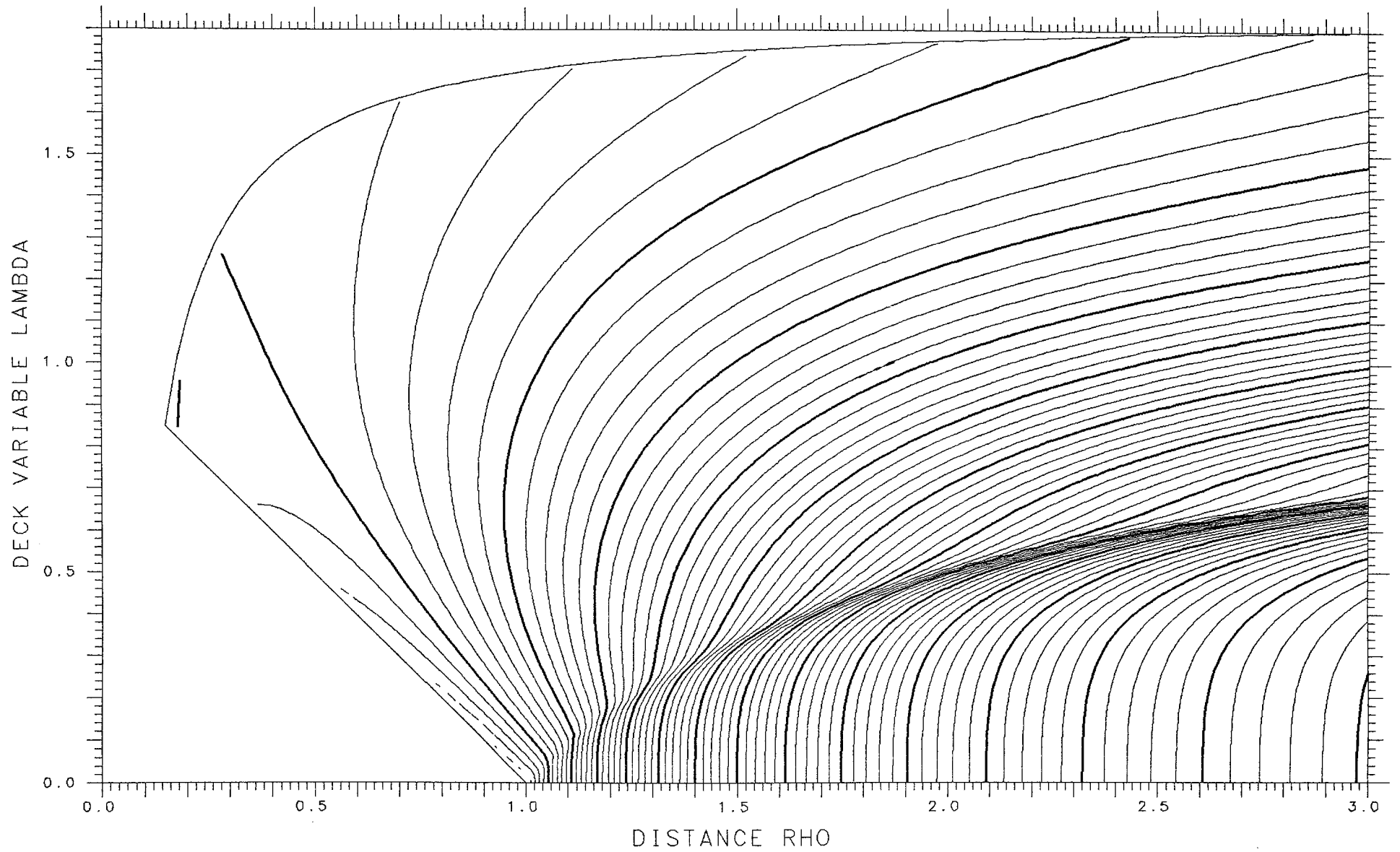

X= .150 ASYMMETRY DELTA= .300 FRACTIONAL= .8650

SPHERES .11726 TANGENT .15710 LENGTH 5.830 ENERGY 188.01 SPACING .005

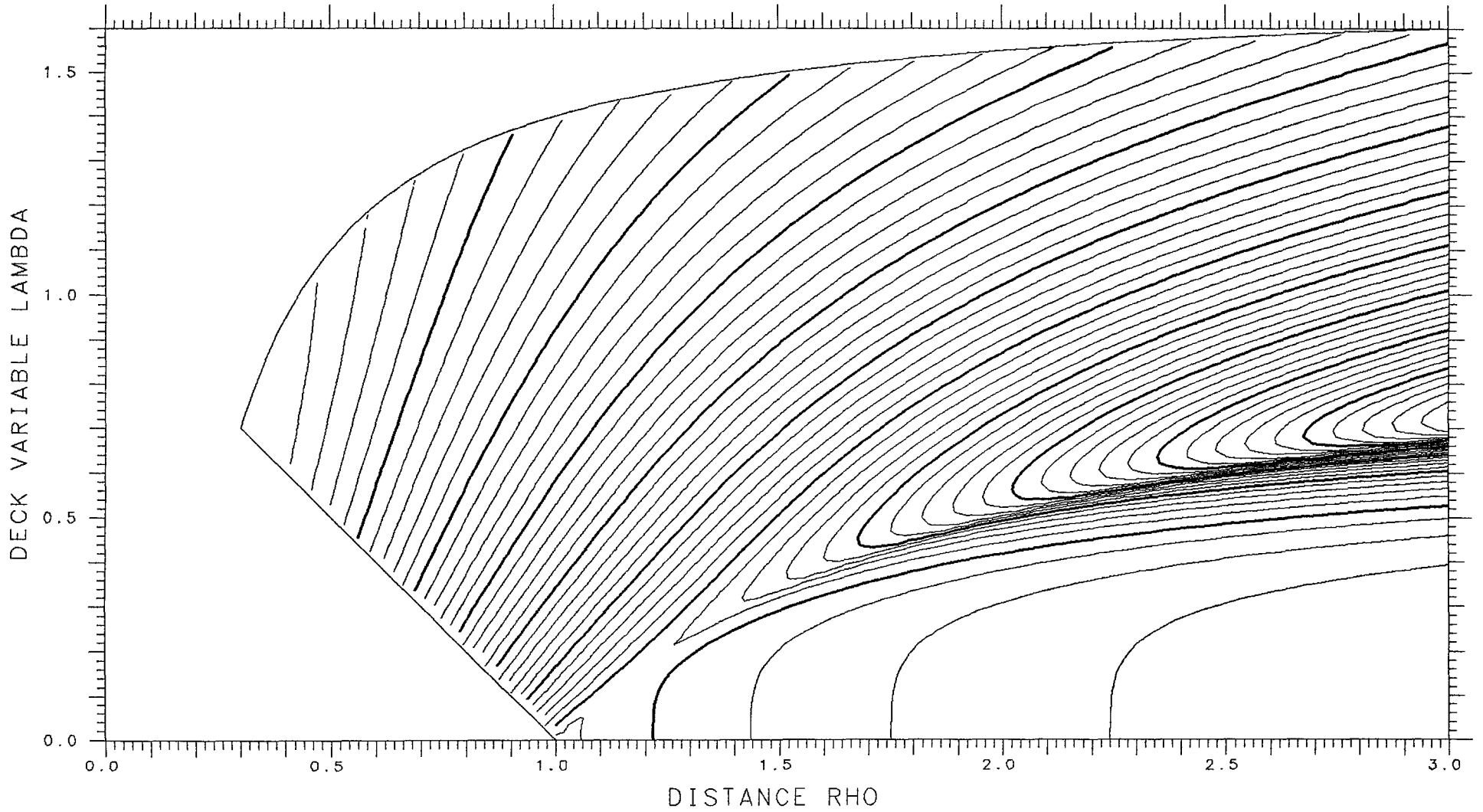

X=1.200

ASYMMETRY DELTA= .125

FRACTIONAL= .6800

SPHERES -.53753

TANGENT .01919

LENGTH 14.063

ENERGY 845.81

SPACING .005

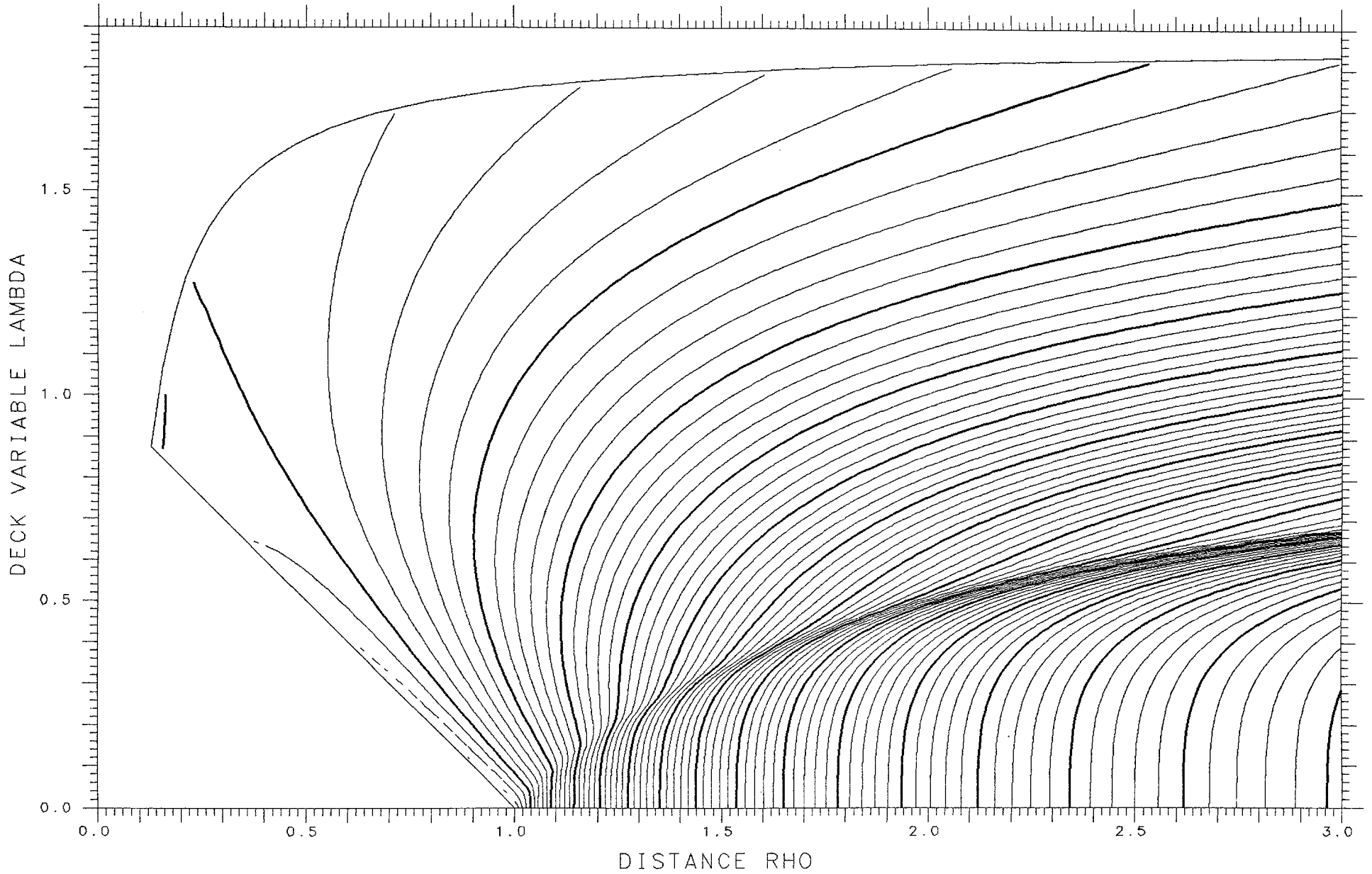

X= .150 ASYMMETRY DELTA= .325 FRACTIONAL= .8832

SPHERES .11174 TANGENT .14735 LENGTH 5.760 ENERGY 188.01 SPACING .005

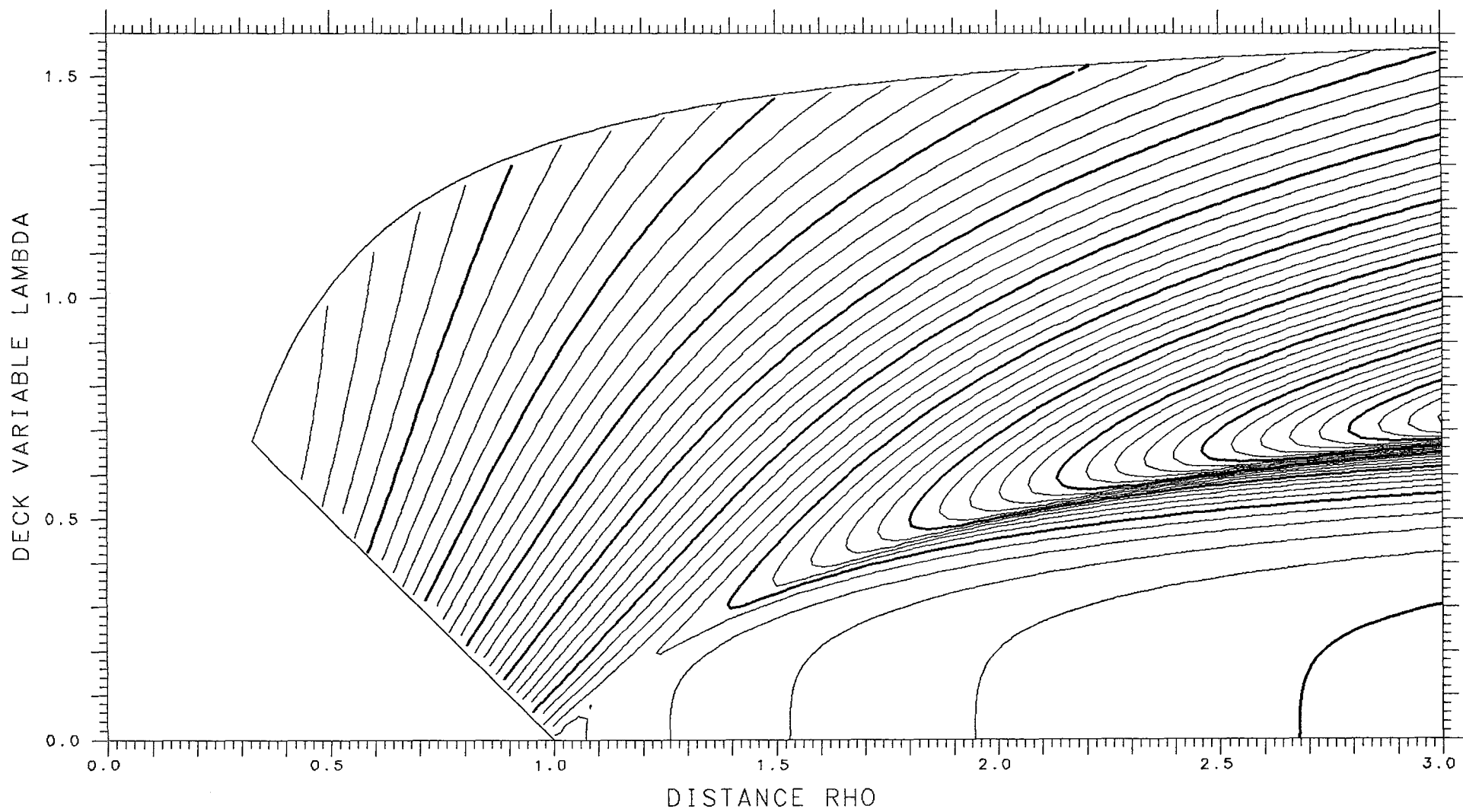

X=1.200 ASYMMETRY DELTA= .100 FRACTIONAL= .6461

SPHERES -.56844 TANGENT .01343 LENGTH 14.140 ENERGY 845.81 SPACING .005

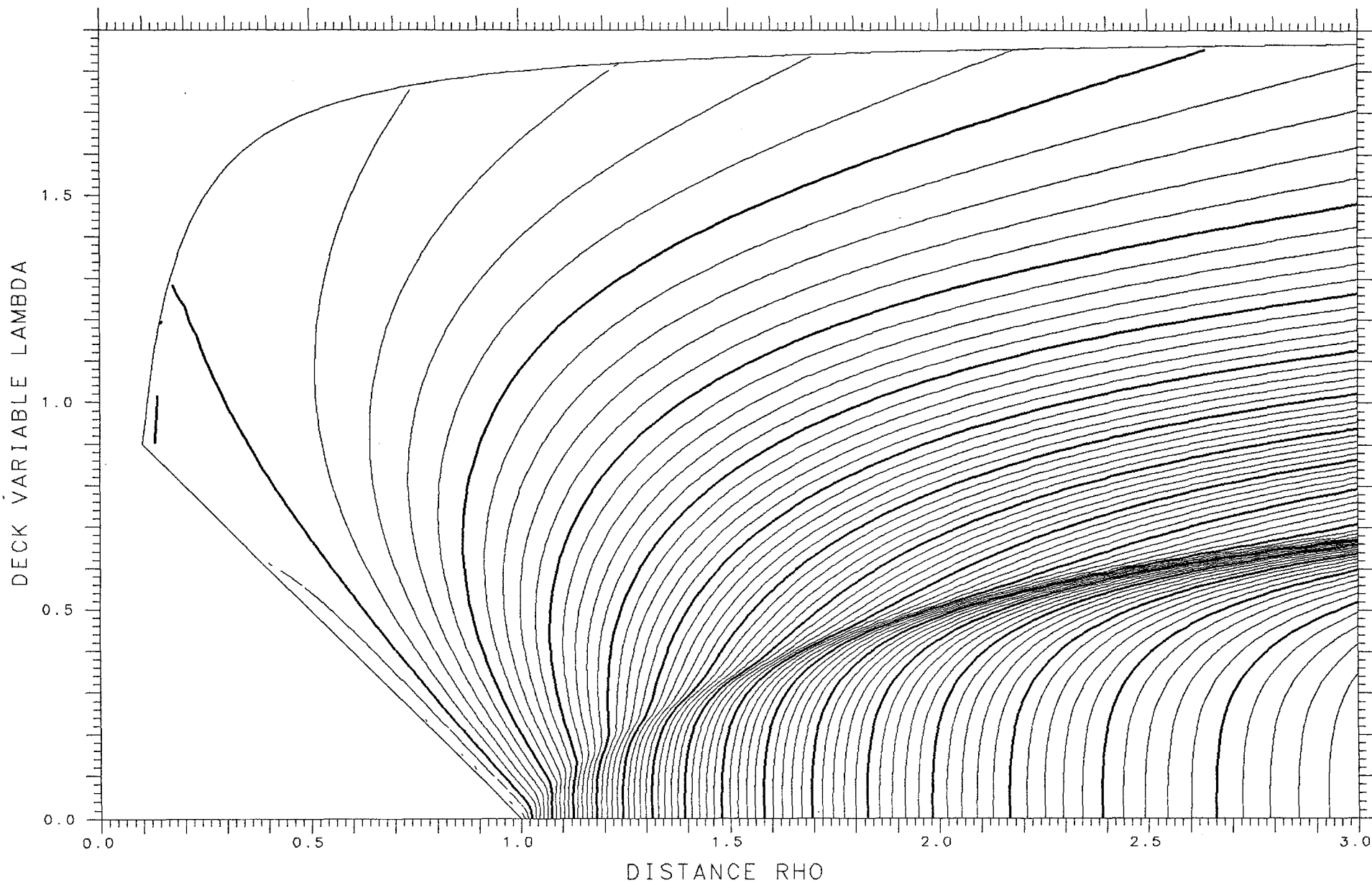

DECK VARIABLE LAMBDA

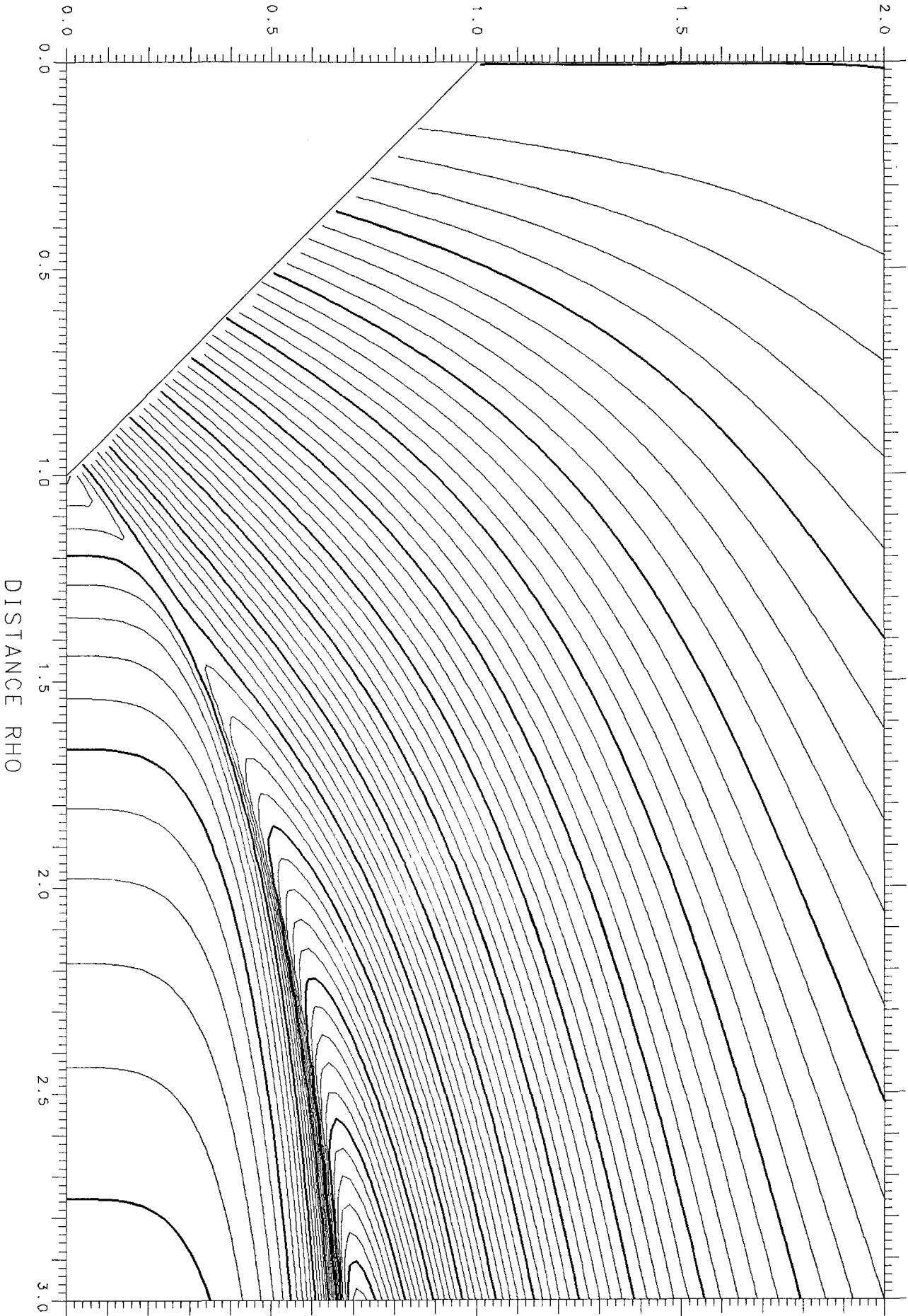

X = .200 ASYMMETRY DELTA=0. FRACTIONAL = .5000
SPHERES .11191 TANGENT .21690 LENGTH 7.029 ENERGY 231.99 SPACING .005

X=1.200

ASYMMETRY DELTA= .075

FRACTIONAL= .6108

SPHERES -.59379

TANGENT .00856

LENGTH 14.200

ENERGY 845.81

SPACING .005

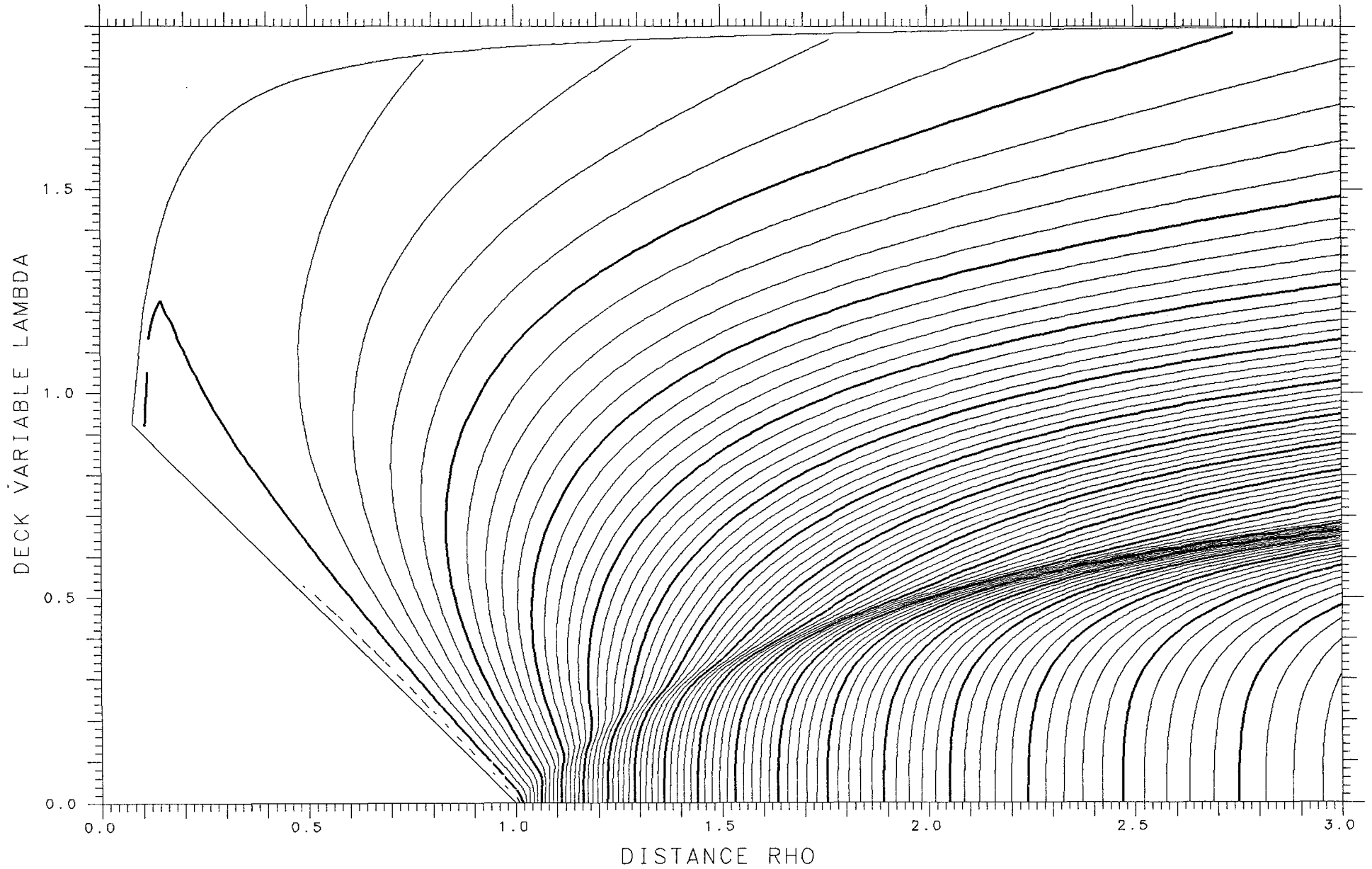

X= .200 ASYMMETRY DELTA= .025 FRACTIONAL= .5374

SPHERES .11190 TANGENT .21637 LENGTH 7.024 ENERGY 231.99 SPACING .005

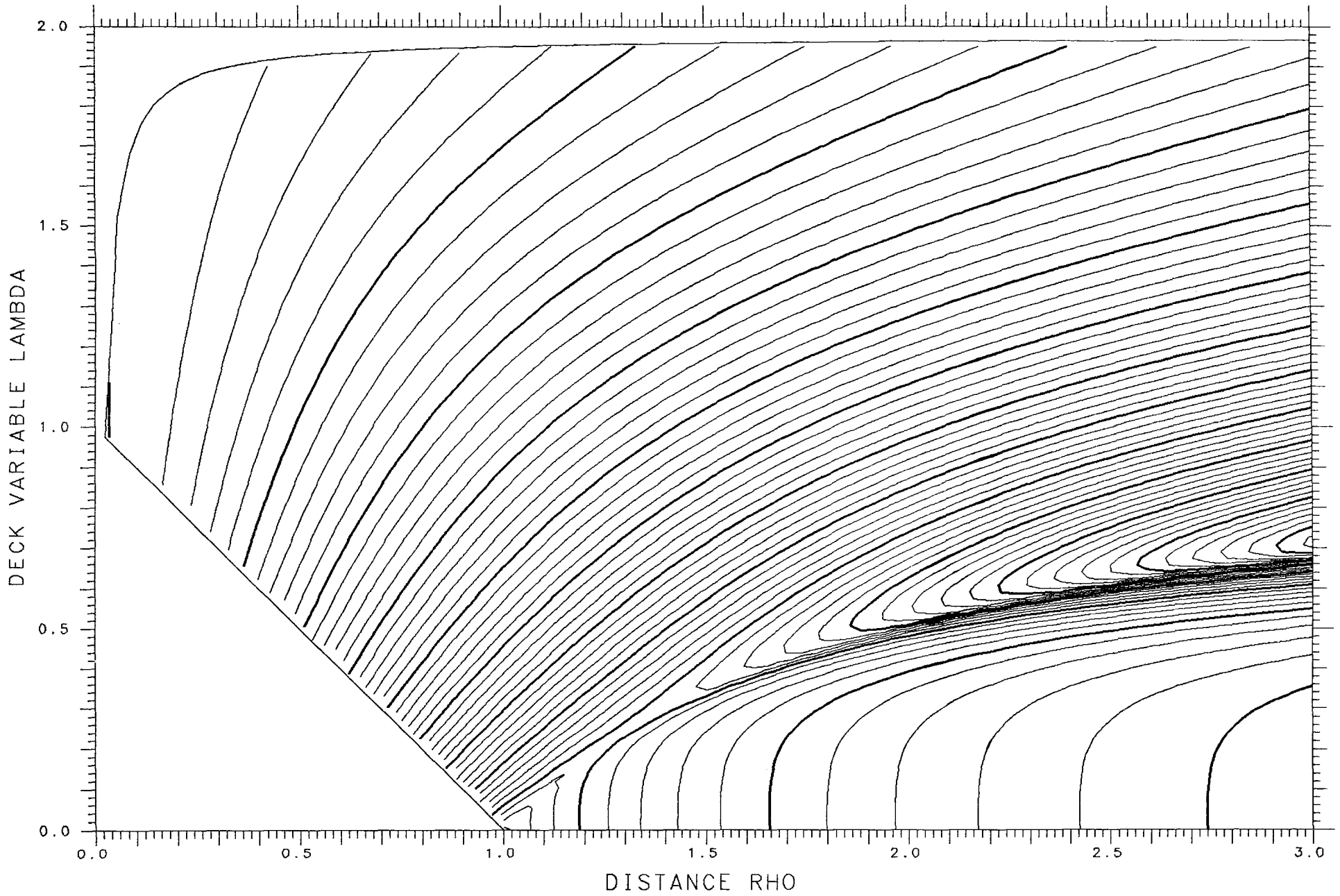

X=1.200

ASYMMETRY DELTA= .050

FRACTIONAL= .5745

SPHERES -.61264

TANGENT .00487

LENGTH 14.244

ENERGY 845.81

SPACING .005

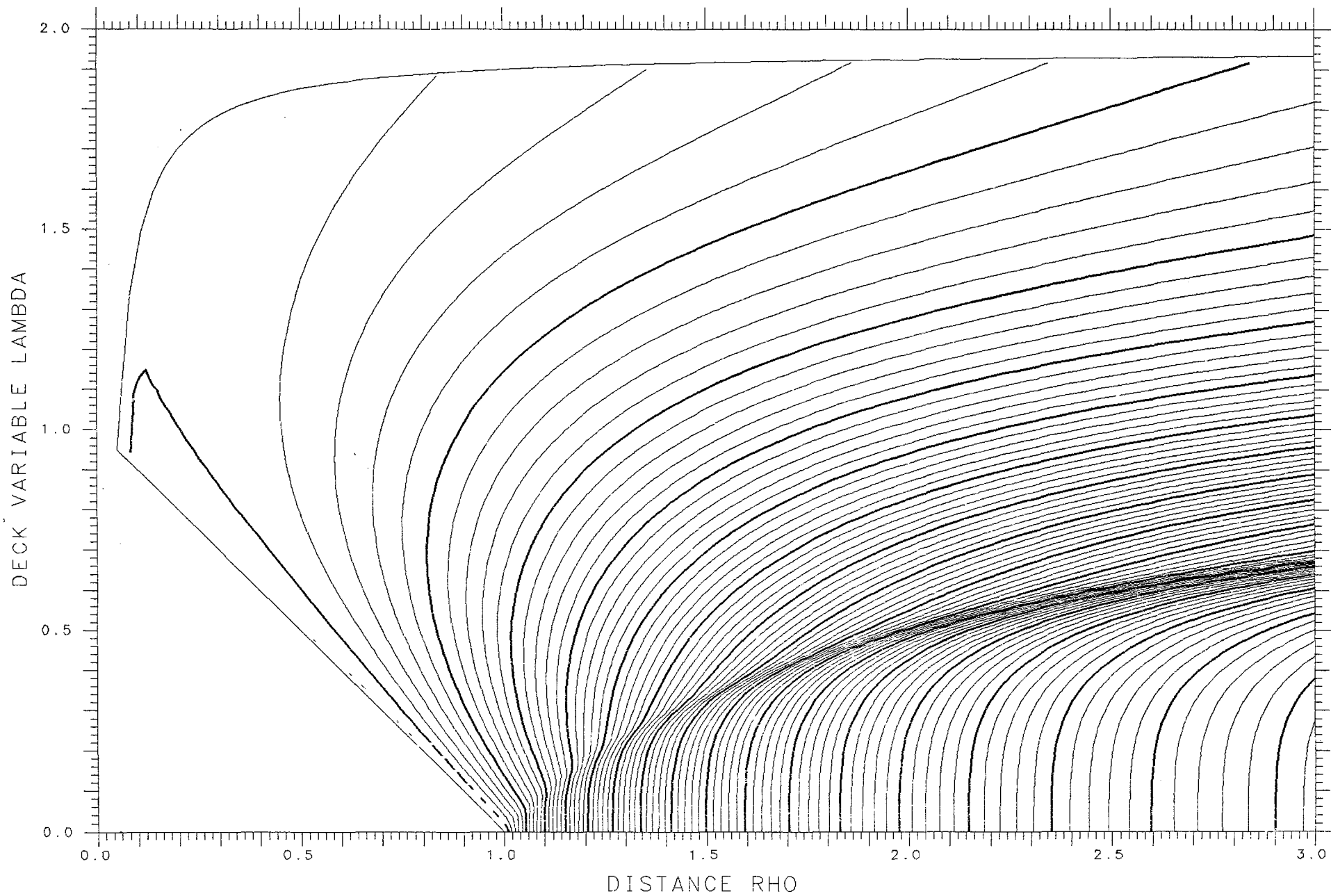

DECK VARIABLE LAMBDA

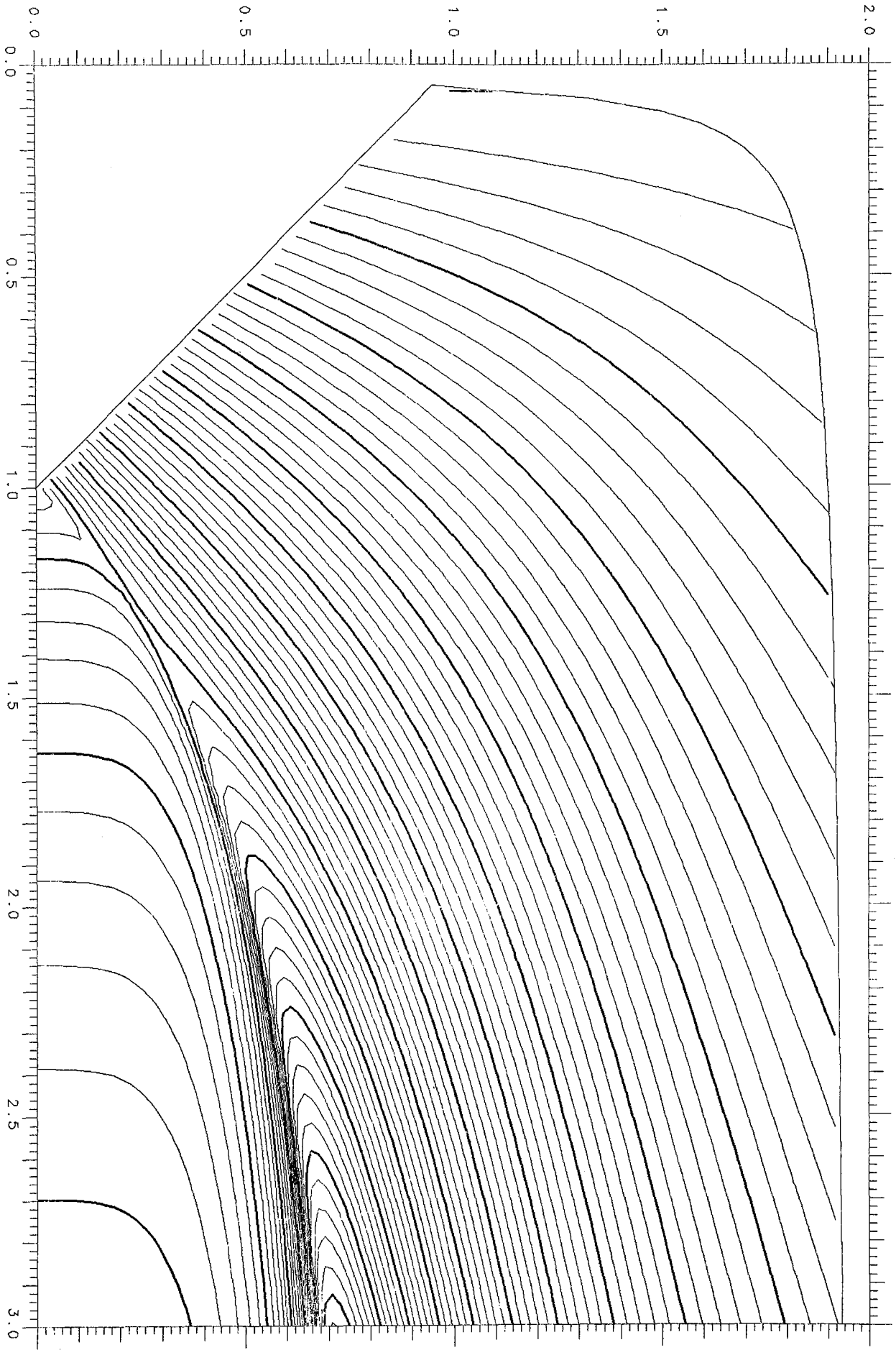

X = .200 ASYMMETRY DELTA = .050 FRACTIONAL = .5745
SPHERES .11189 TANGENT .21481 LENGTH 7.011 ENERGY 231.99 SPACING .005

DISTANCE RHO

X=1.200

ASYMMETRY DELTA= .025

FRACTIONAL= .5374

SPHERES -.62425

TANGENT .00257

LENGTH 14.271

ENERGY 845.81

SPACING .005

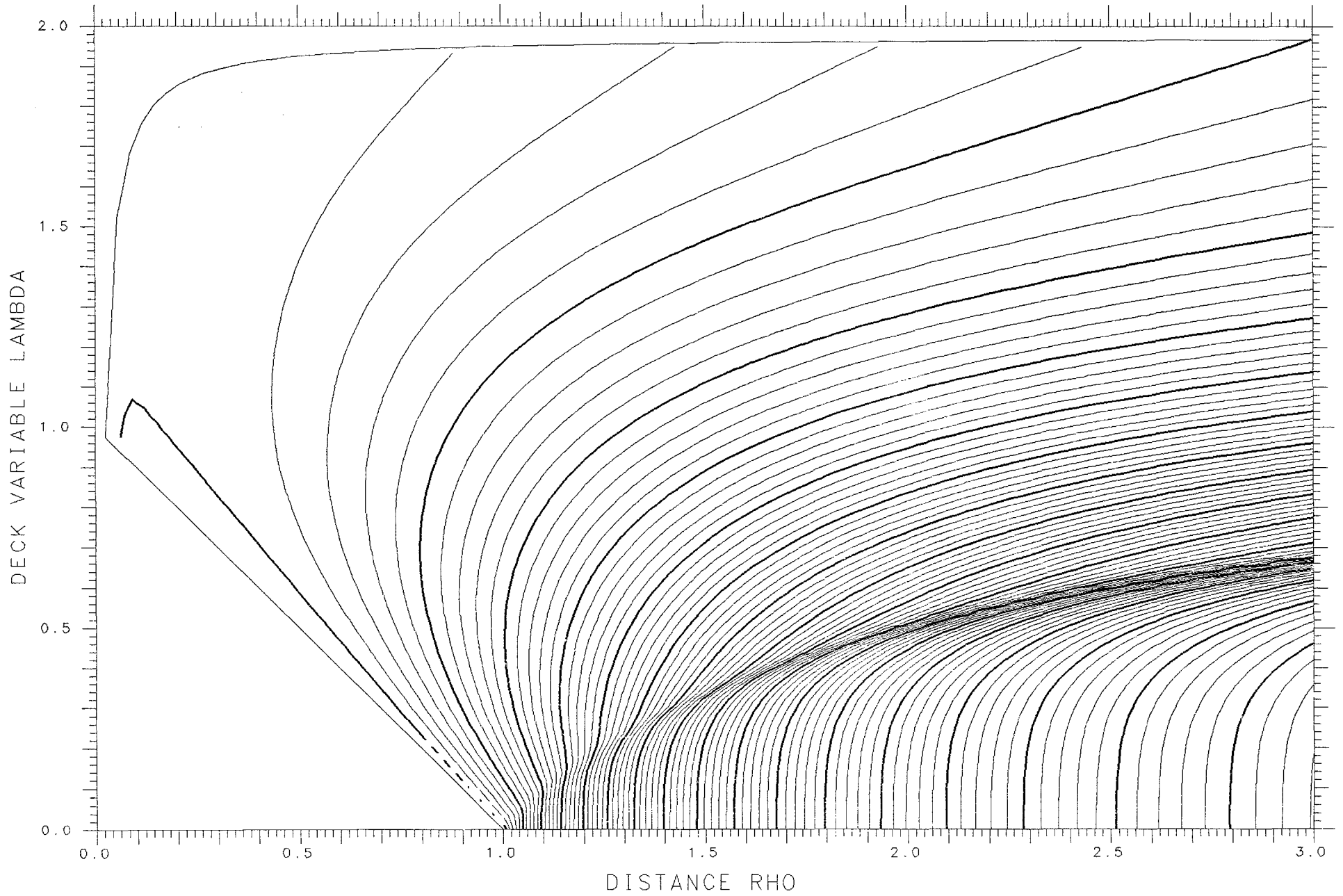

X= .200 ASYMMETRY DELTA= .075 FRACTIONAL= .6108

SPHERES .11183 TANGENT .21222 LENGTH 6.990 ENERGY 231.99 SPACING .005

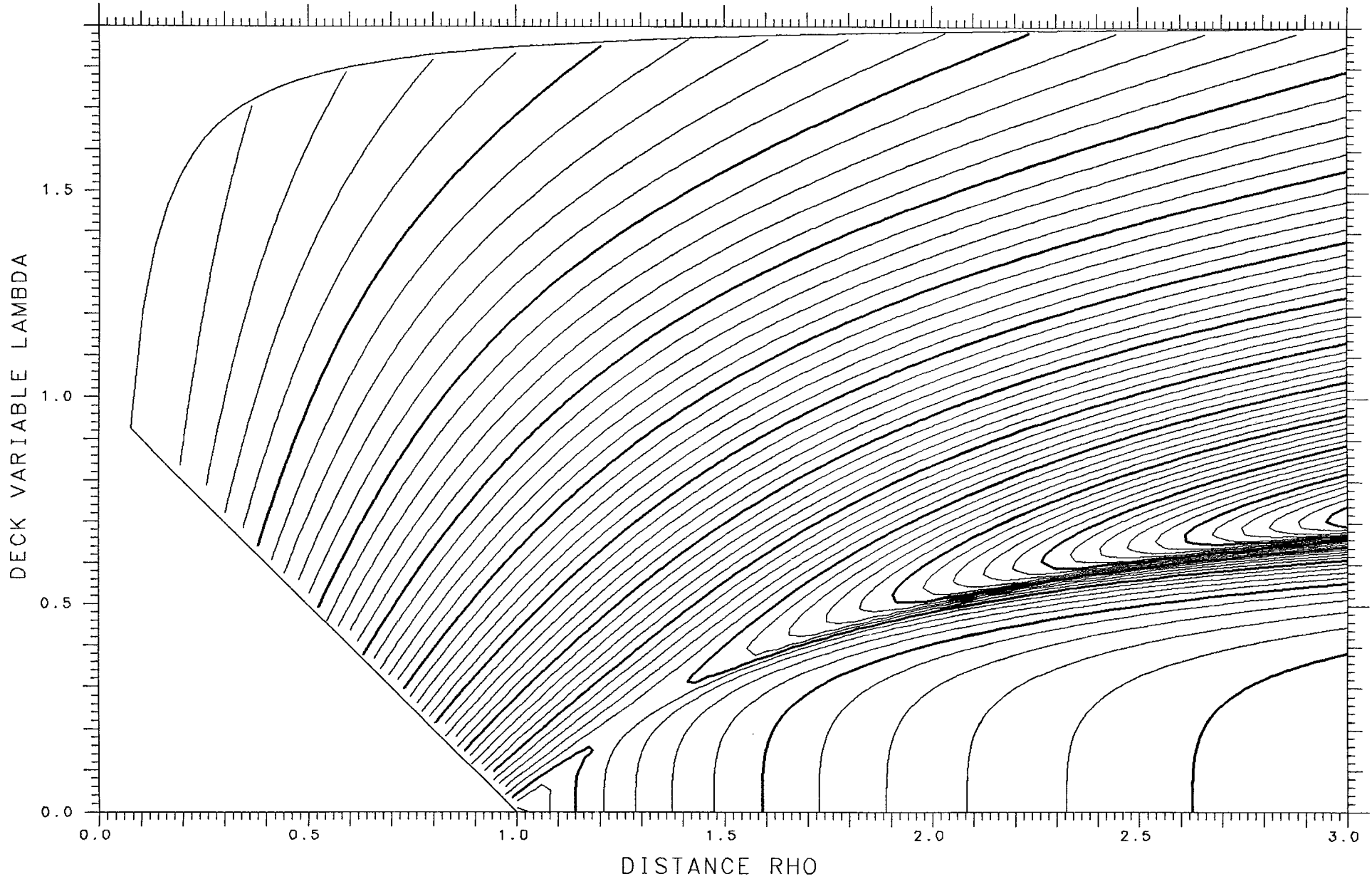

X=1.200

ASYMMETRY DELTA=0.

FRACTIONAL= .5000

SPHERES -.62817

TANGENT .00179

LENGTH 14.280

ENERGY 845.81

SPACING .005

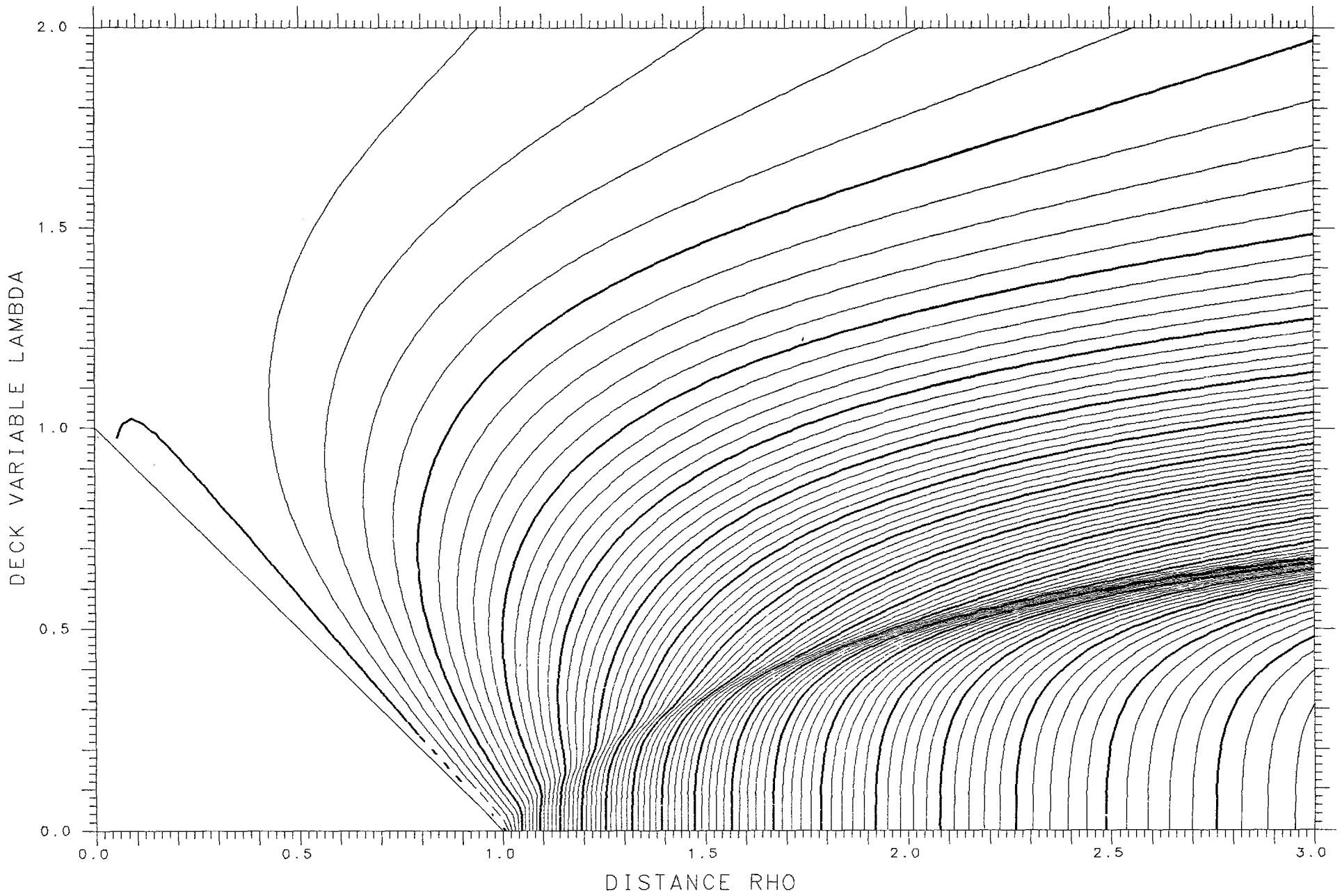

X= .200 ASYMMETRY DELTA= .100 FRACTIONAL= .6461

SPHERES .11167 TANGENT .20865 LENGTH 6.960 ENERGY 231.99 SPACING .005

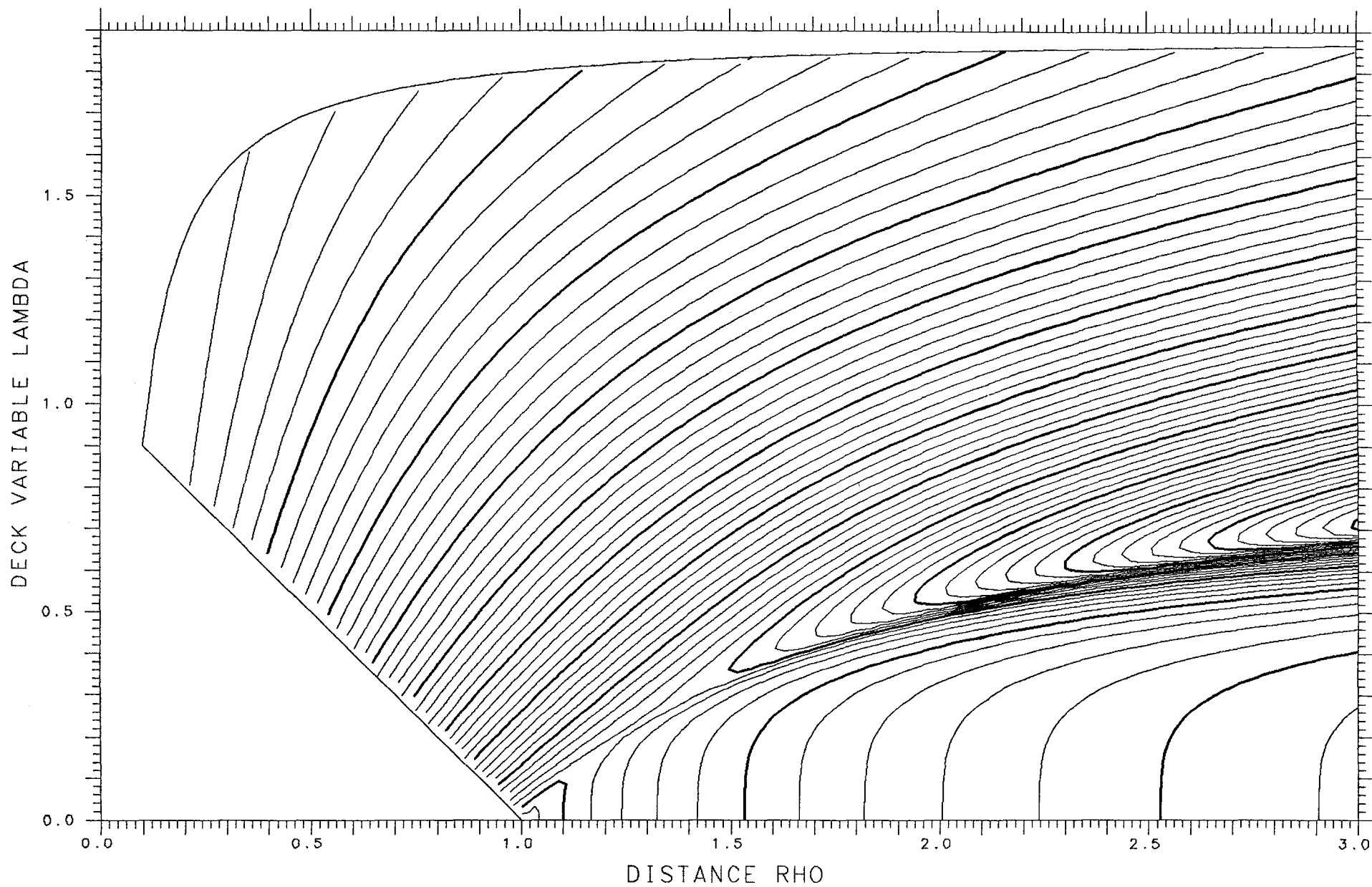

X=1.150 ASYMMETRY DELTA= .225 FRACTIONAL= .7979

SPHERES -.35647 TANGENT .05167 LENGTH 13.398 ENERGY 822.07 SPACING .005

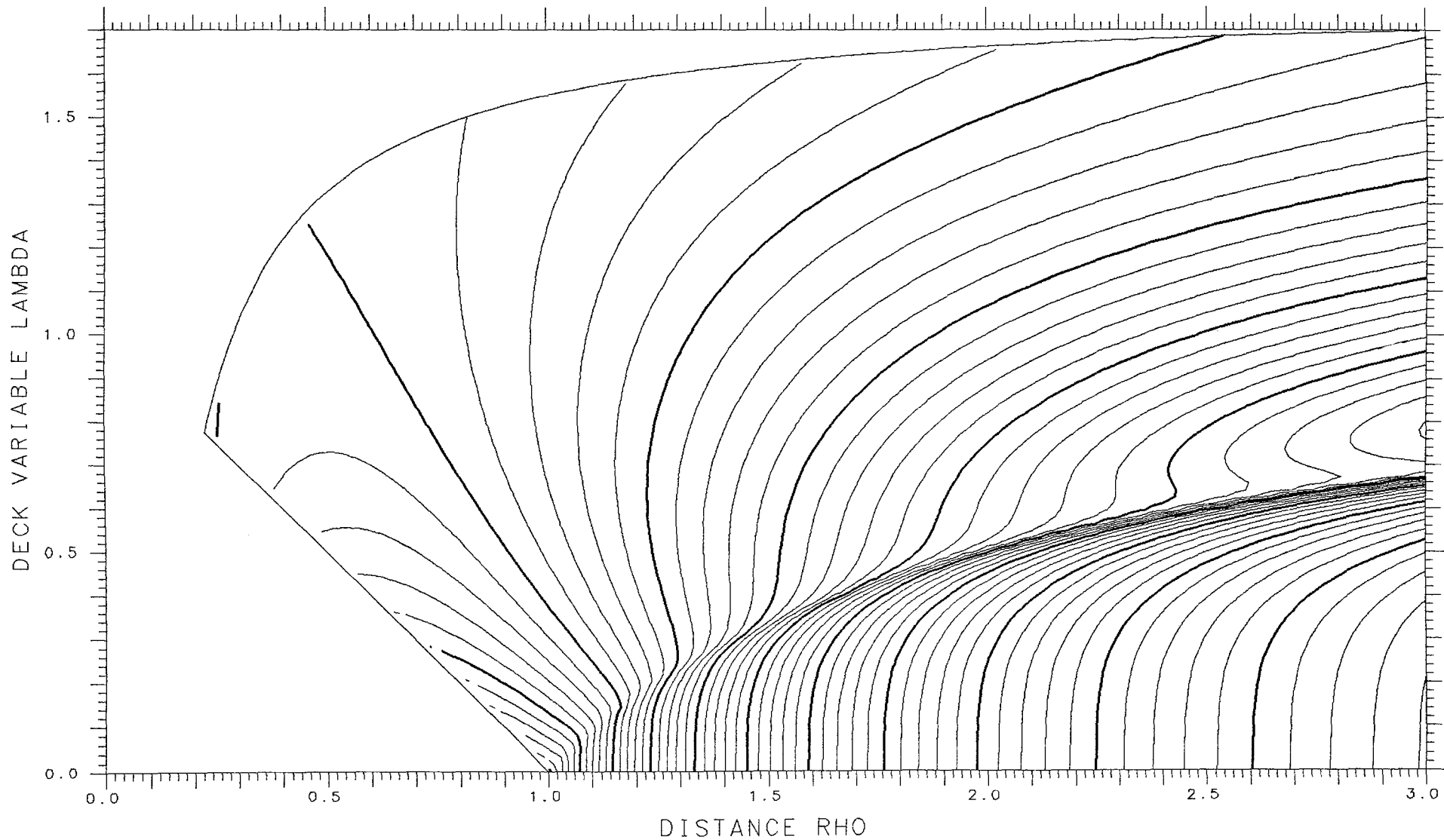

X= .200 ASYMMETRY DELTA= .125 FRACTIONAL= .6800

SPHERES .11134 TANGENT .20413 LENGTH 6.922 ENERGY 231.99 SPACING .005

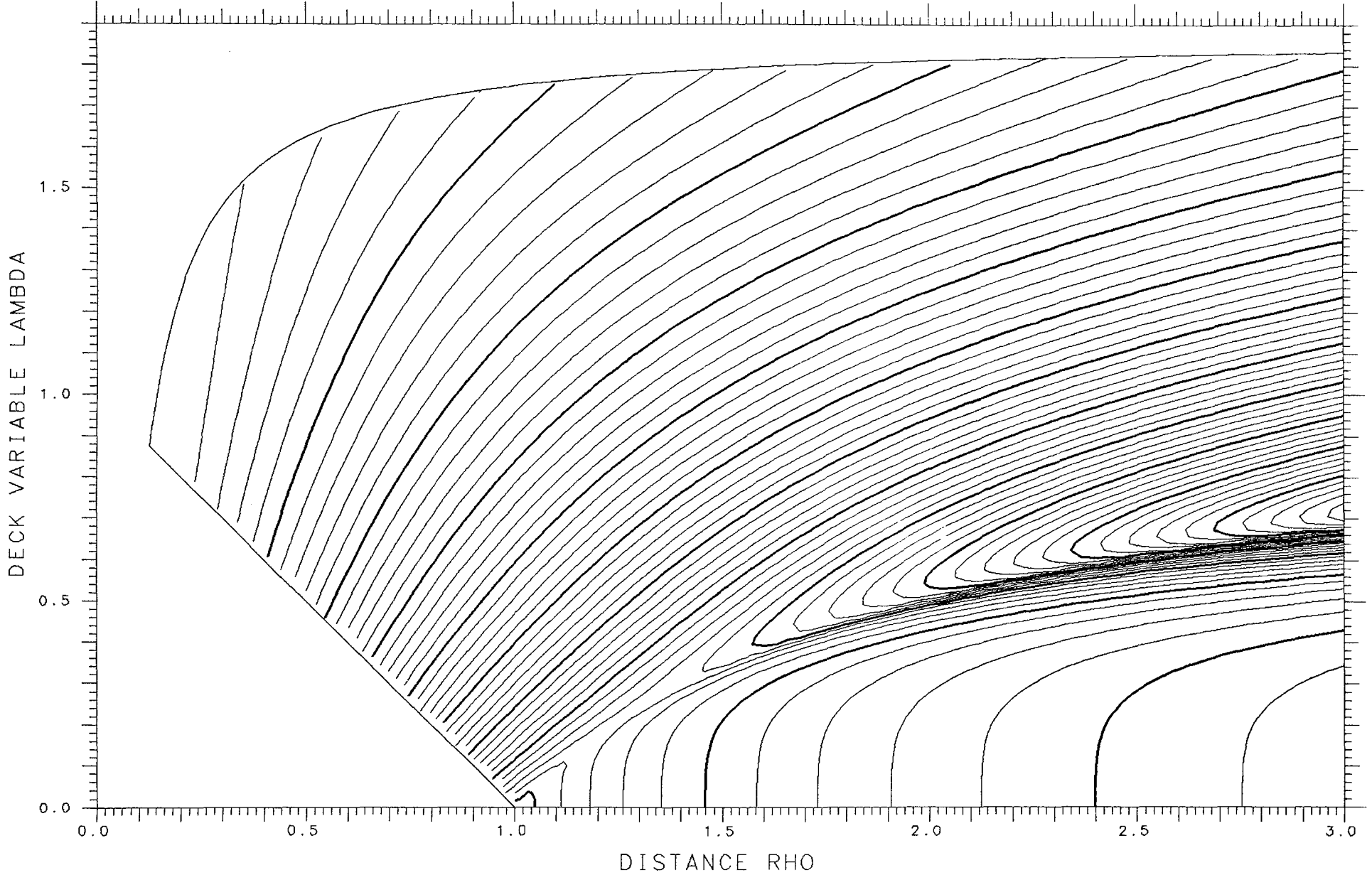

X=1.150 ASYMMETRY DELTA= .200 FRACTIONAL= .7714

SPHERES -.39609 TANGENT .04610 LENGTH 13.523 ENERGY 822.07 SPACING .005

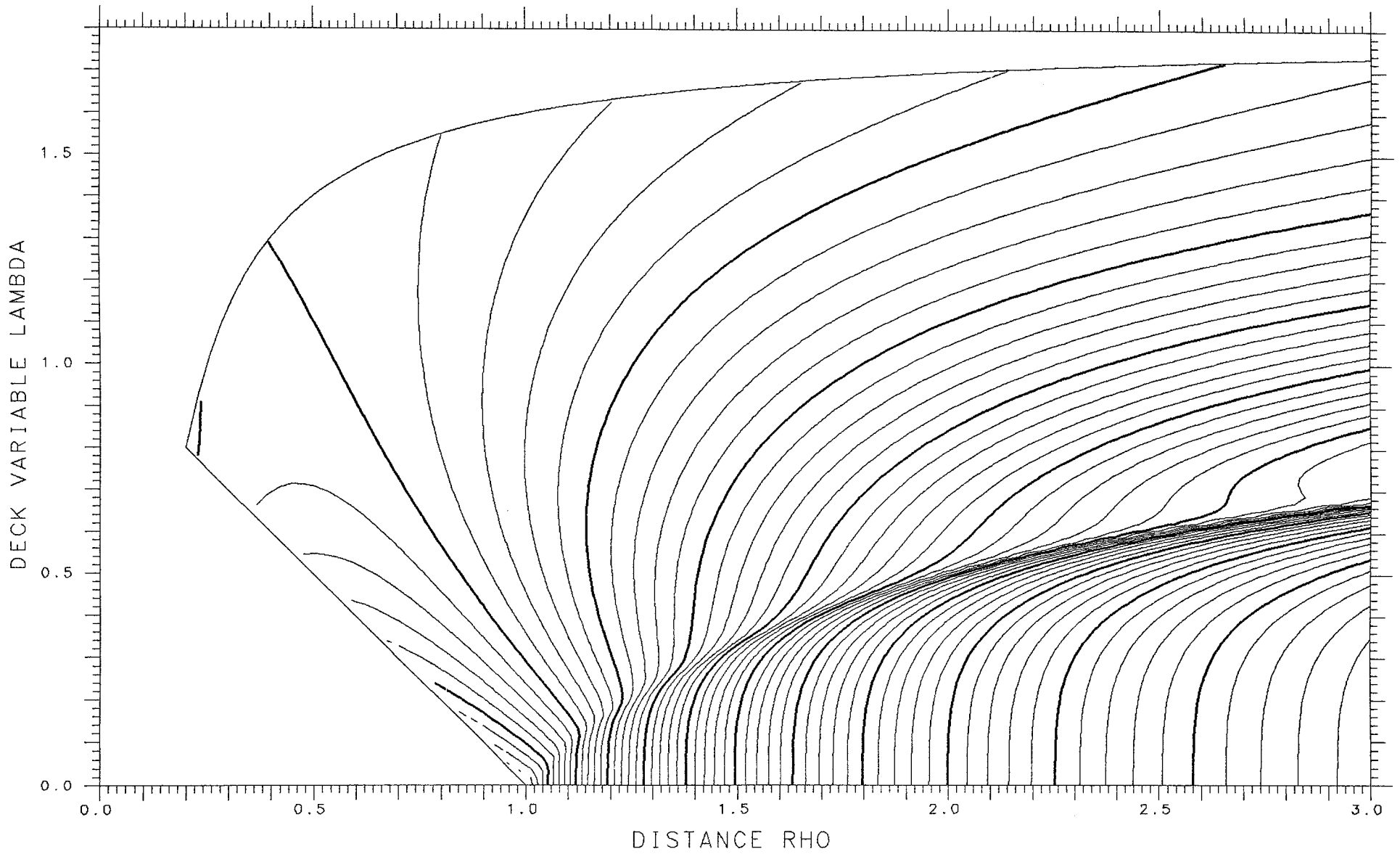

X= .200 ASYMMETRY DELTA= .150 FRACTIONAL= .7124

SPHERES .11079 TANGENT .19874 LENGTH 6.877 ENERGY 231.99 SPACING .005

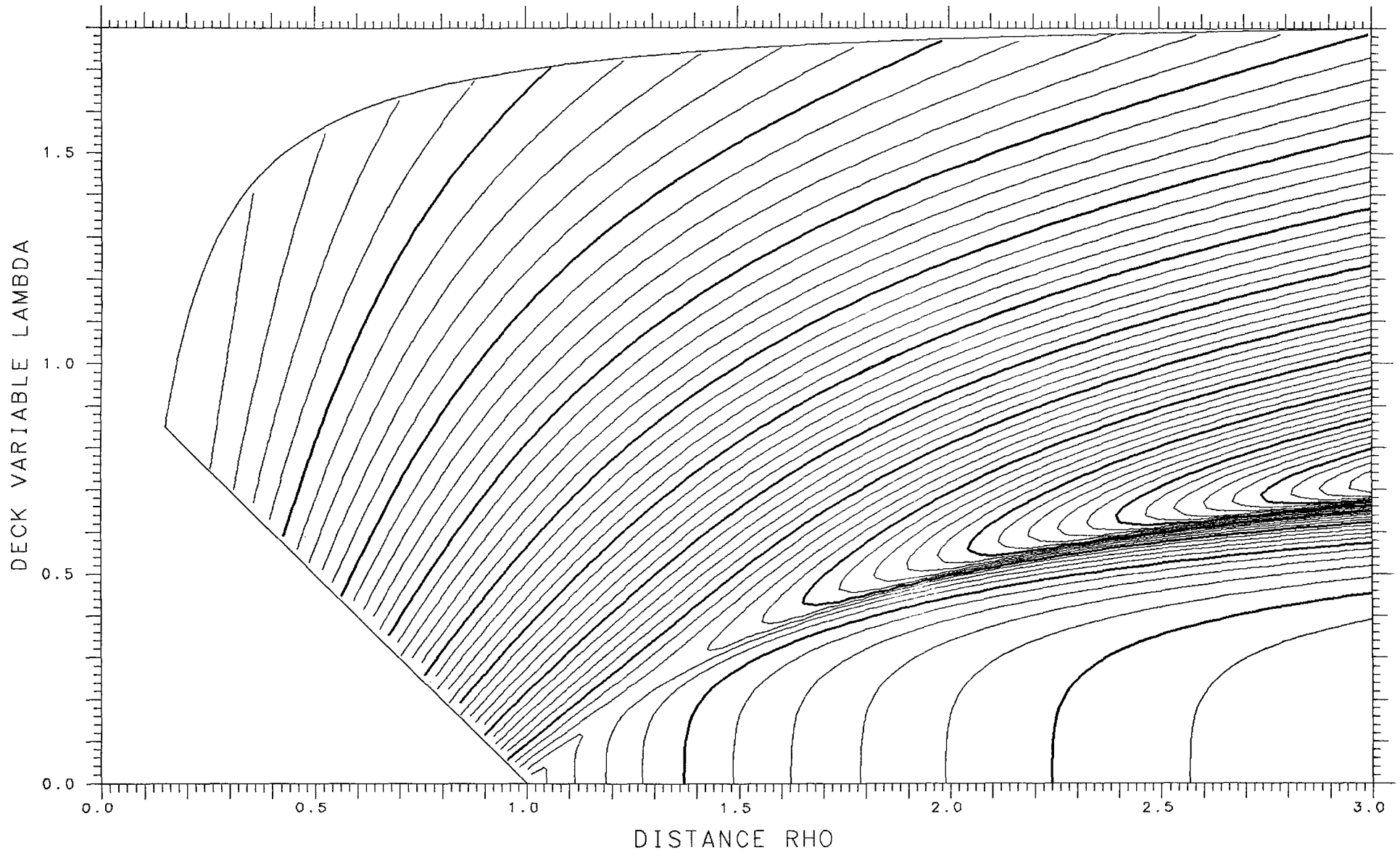

X=1.150

ASYMMETRY DELTA= .175

FRACTIONAL= .7429

SPHERES -.43480

TANGENT .04019

LENGTH 13.639

ENERGY 822.07

SPACING .005

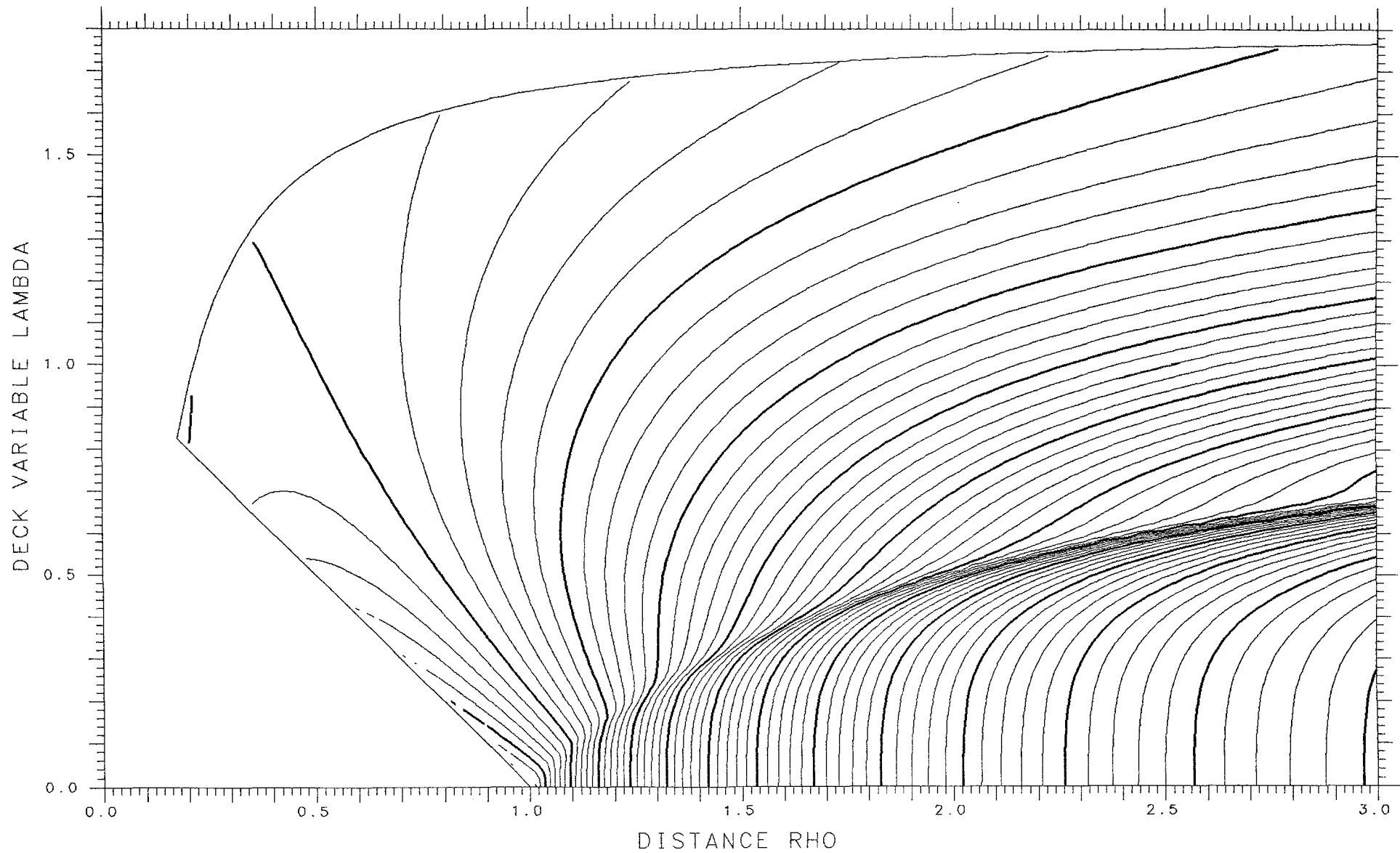

X= .200 ASYMMETRY DELTA= .175 FRACTIONAL= .7429

SPHERES .10992 TANGENT .19253 LENGTH 6.826 ENERGY 231.99 SPACING .005

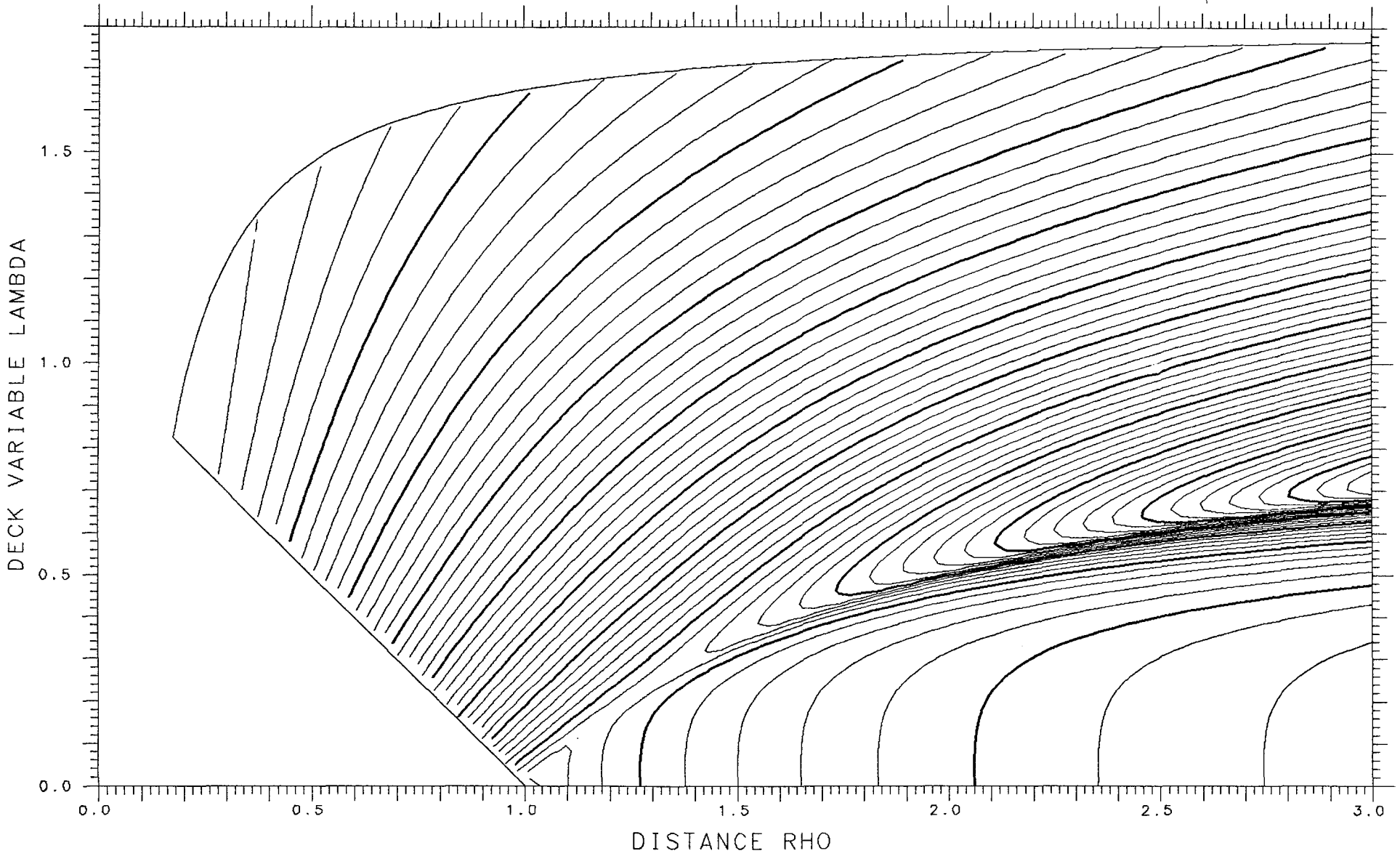

X=1.150

ASYMMETRY DELTA= .150

FRACTIONAL= .7124

SPHERES -.47150

TANGENT .03420

LENGTH 13.742

ENERGY 822.07

SPACING .005

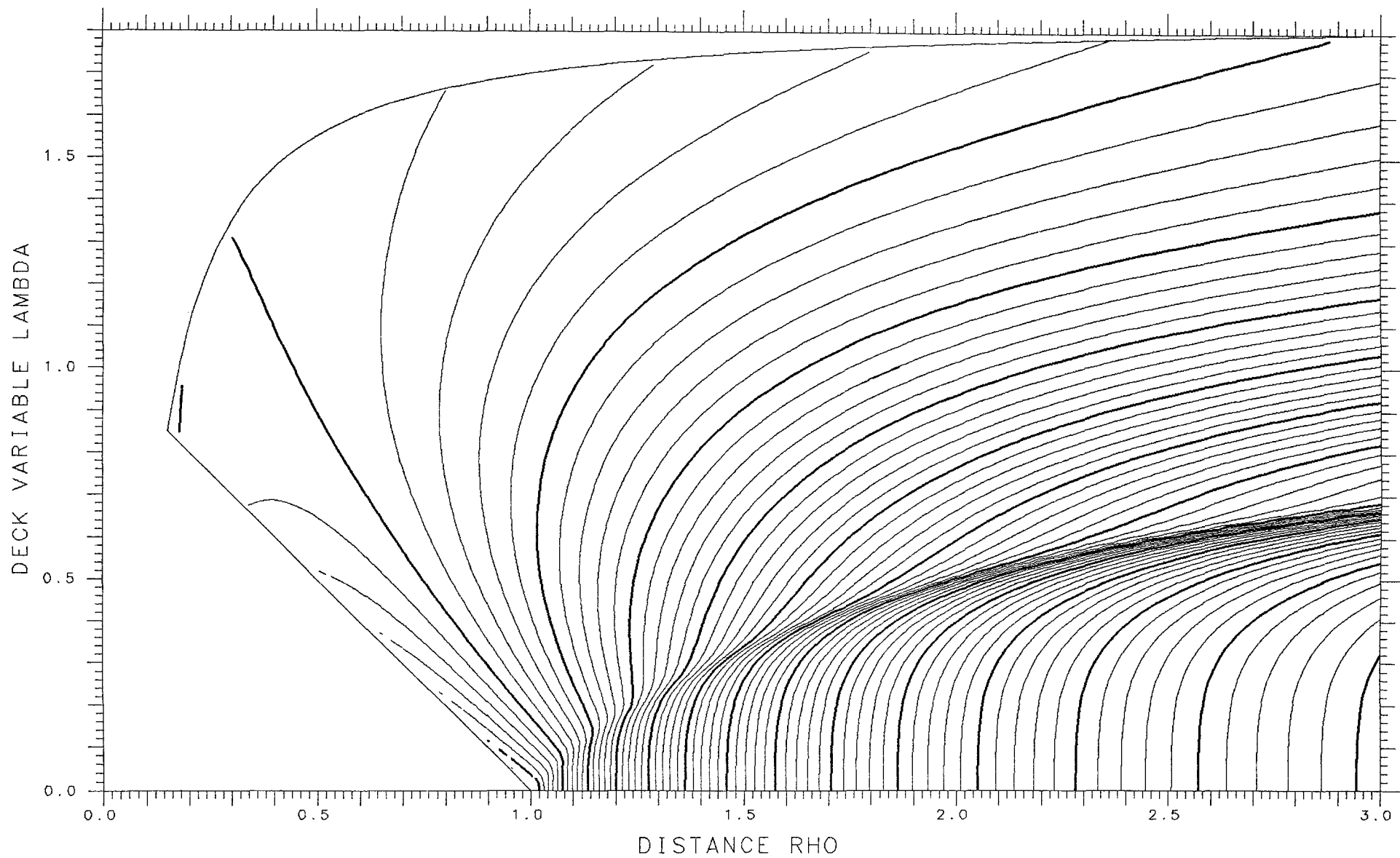

X= .200 ASYMMETRY DELTA= .200 FRACTIONAL= .7714

SPHERES .10870 TANGENT .18560 LENGTH 6.768 ENERGY 231.99 SPACING .005

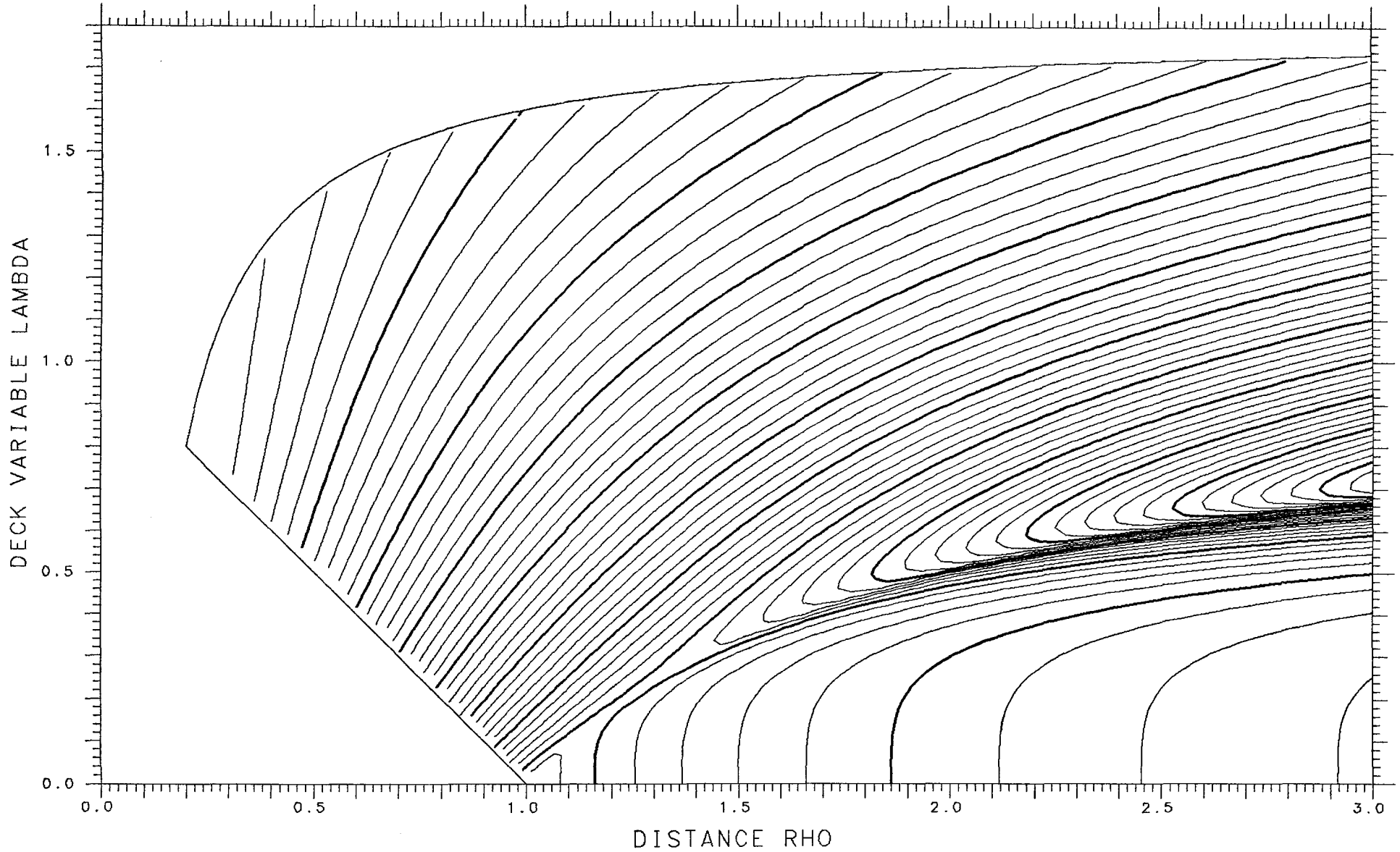

X=1.150

ASYMMETRY DELTA= .125

FRACTIONAL= .6800

SPHERES -.50509

TANGENT .02844

LENGTH 13.831

ENERGY 822.07

SPACING .005

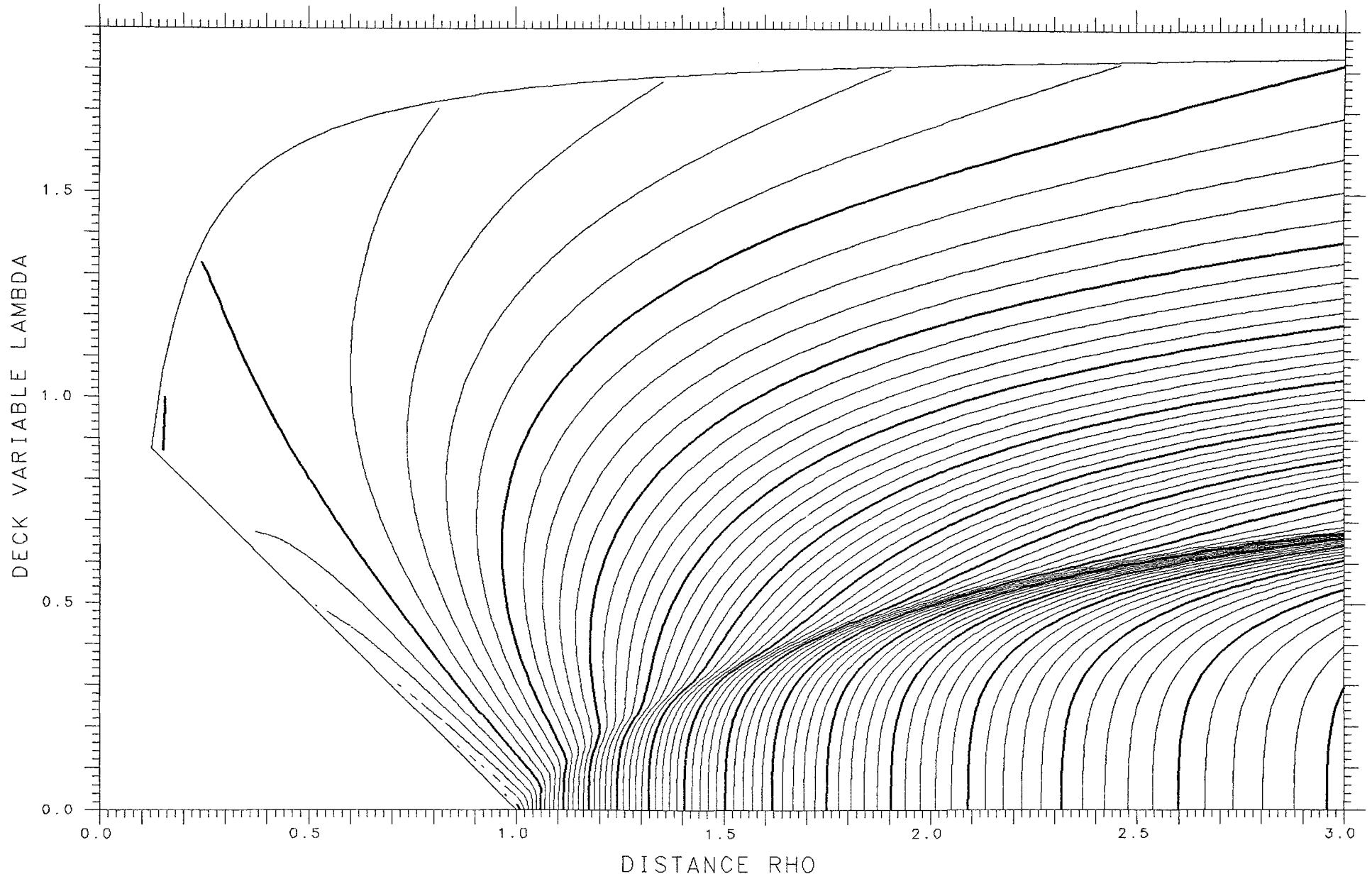

X= .200 ASYMMETRY DELTA= .225 FRACTIONAL= .7979

SPHERES .10705 TANGENT .17803 LENGTH 6.705 ENERGY 231.99 SPACING .005

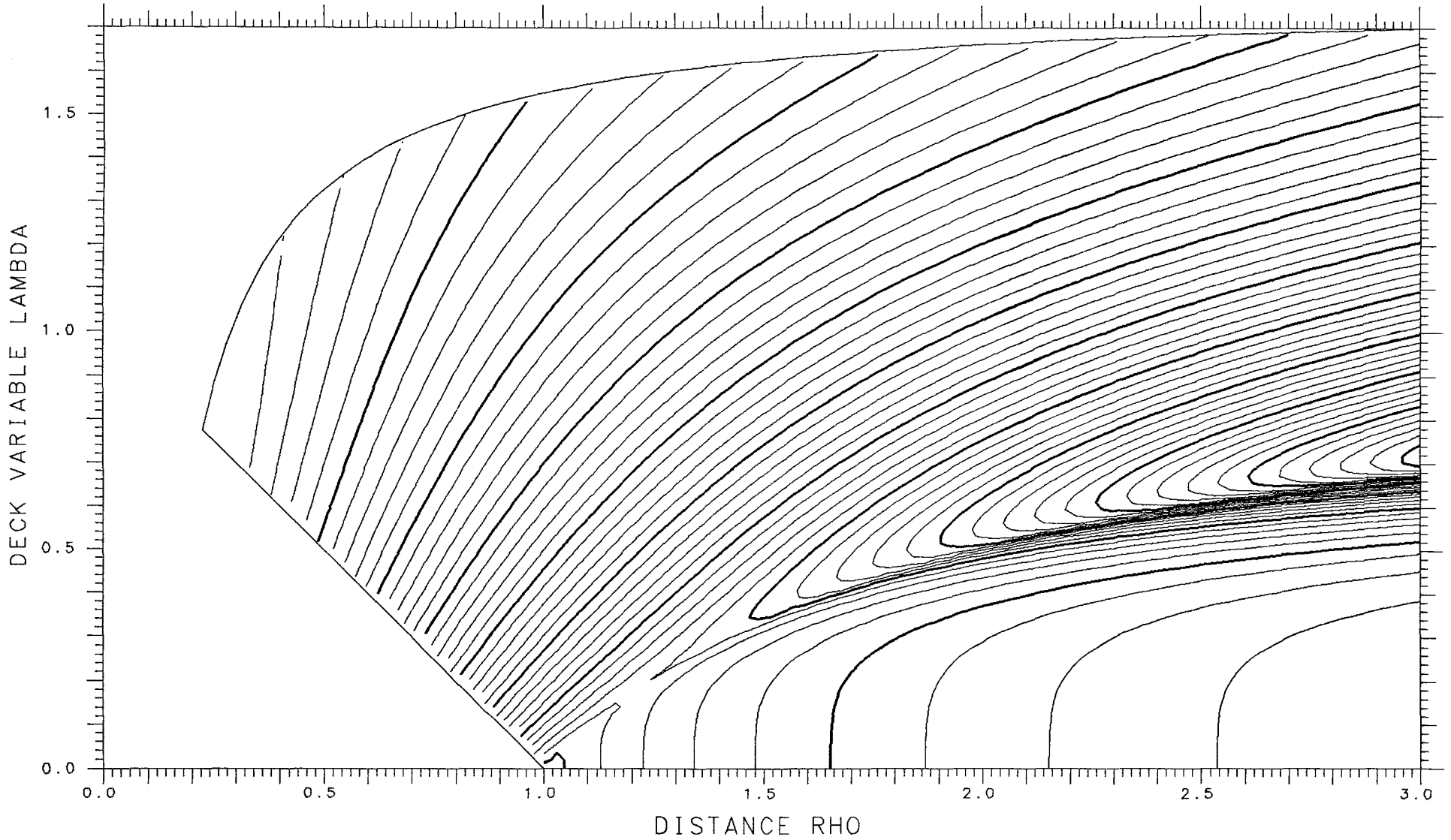

X=1.150

ASYMMETRY DELTA= .100

FRACTIONAL= .6461

SPHERES -.53444

TANGENT .02319

LENGTH 13.906

ENERGY 822.07

SPACING .005

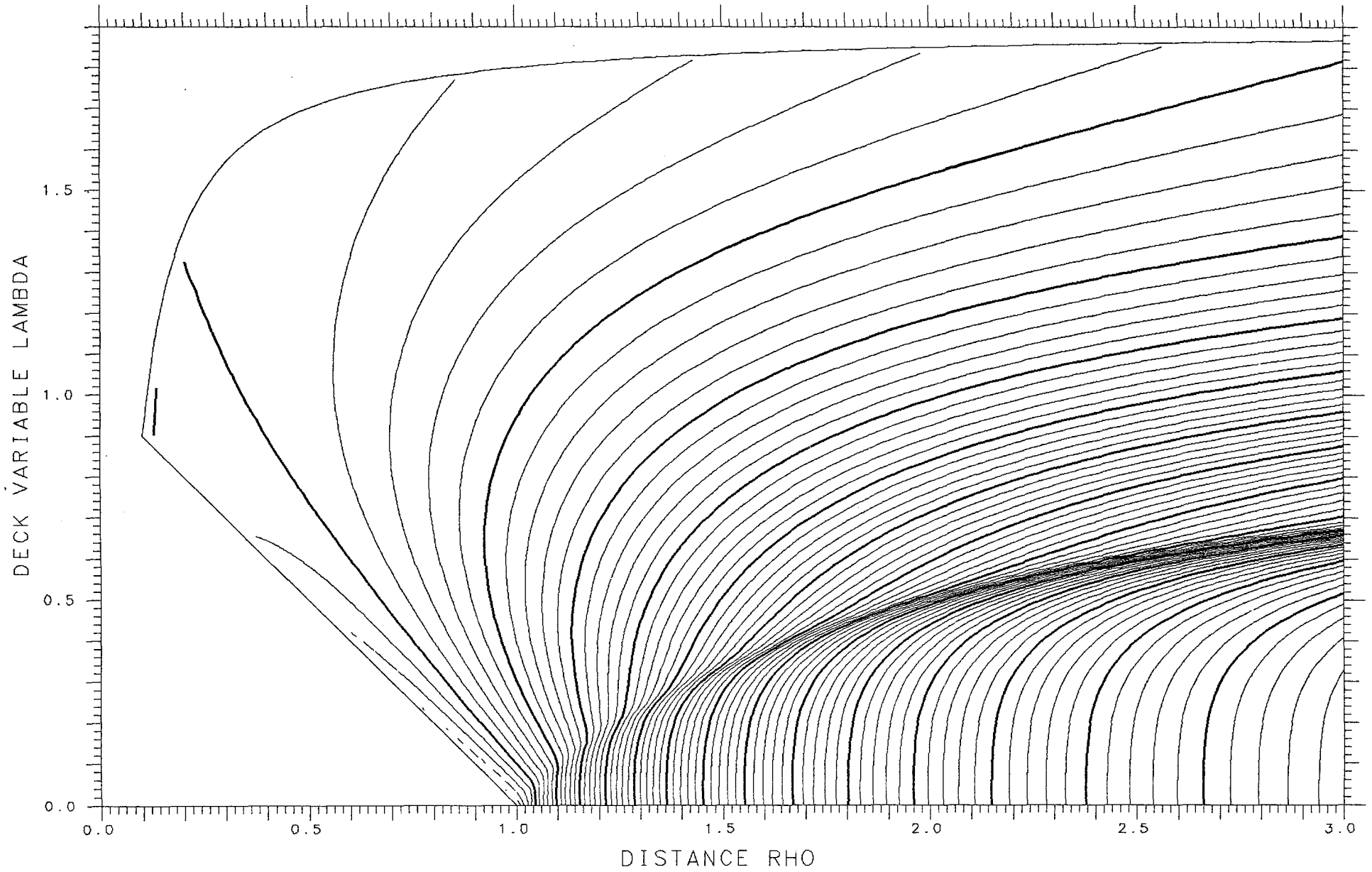

DECK VARIABLE LAMBDA

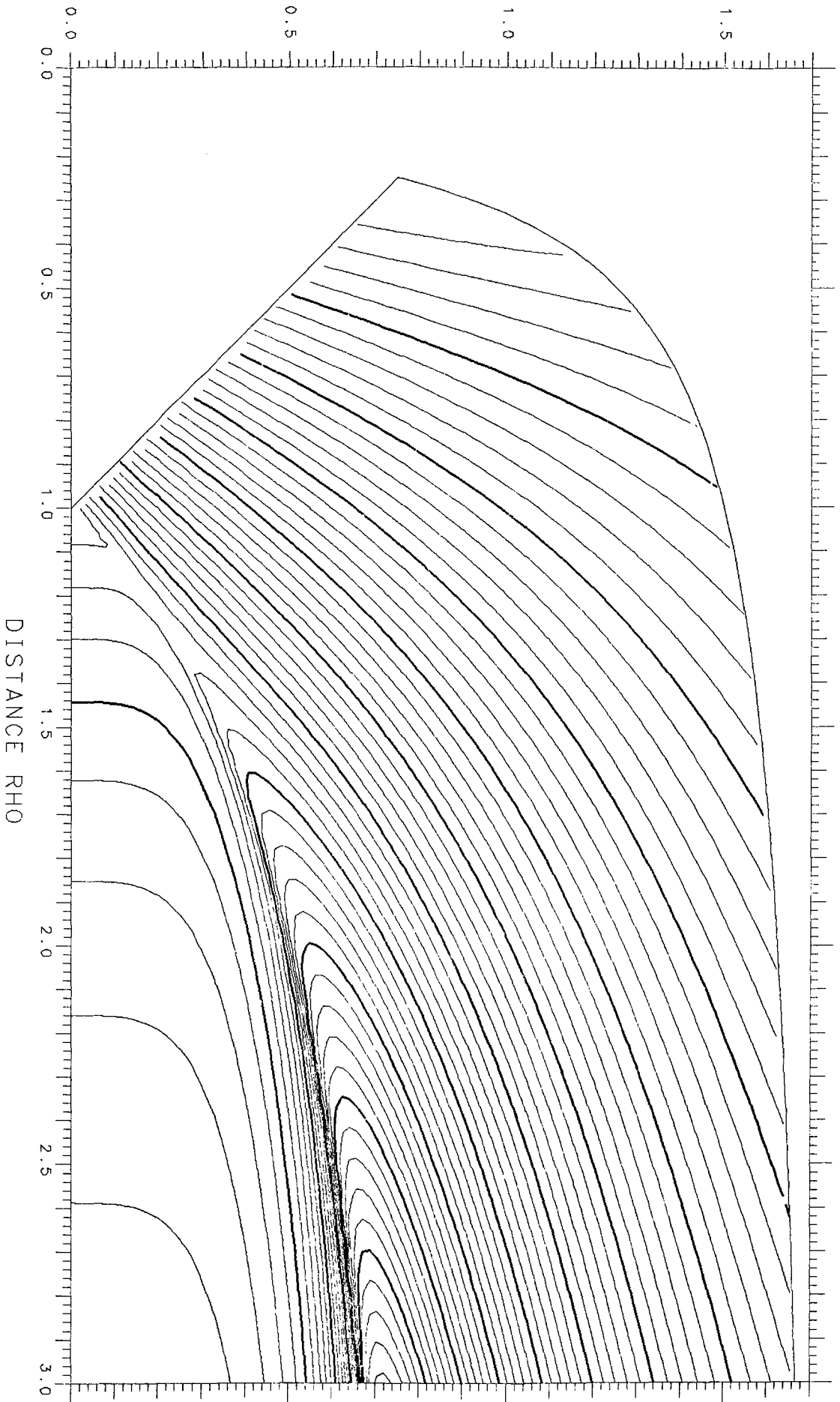

X = .200 ASYMMETRY DELTA = .250 FRACTIONAL = .8224

SPHERES .10495 TANGENT .16992 LENGTH 6.637 ENERGY 231.99 SPACING .005

X=1.150

ASYMMETRY DELTA= .075

FRACTIONAL= .6108

SPHERES -.55851

TANGENT .01875

LENGTH 13.966

ENERGY 822.07

SPACING .005

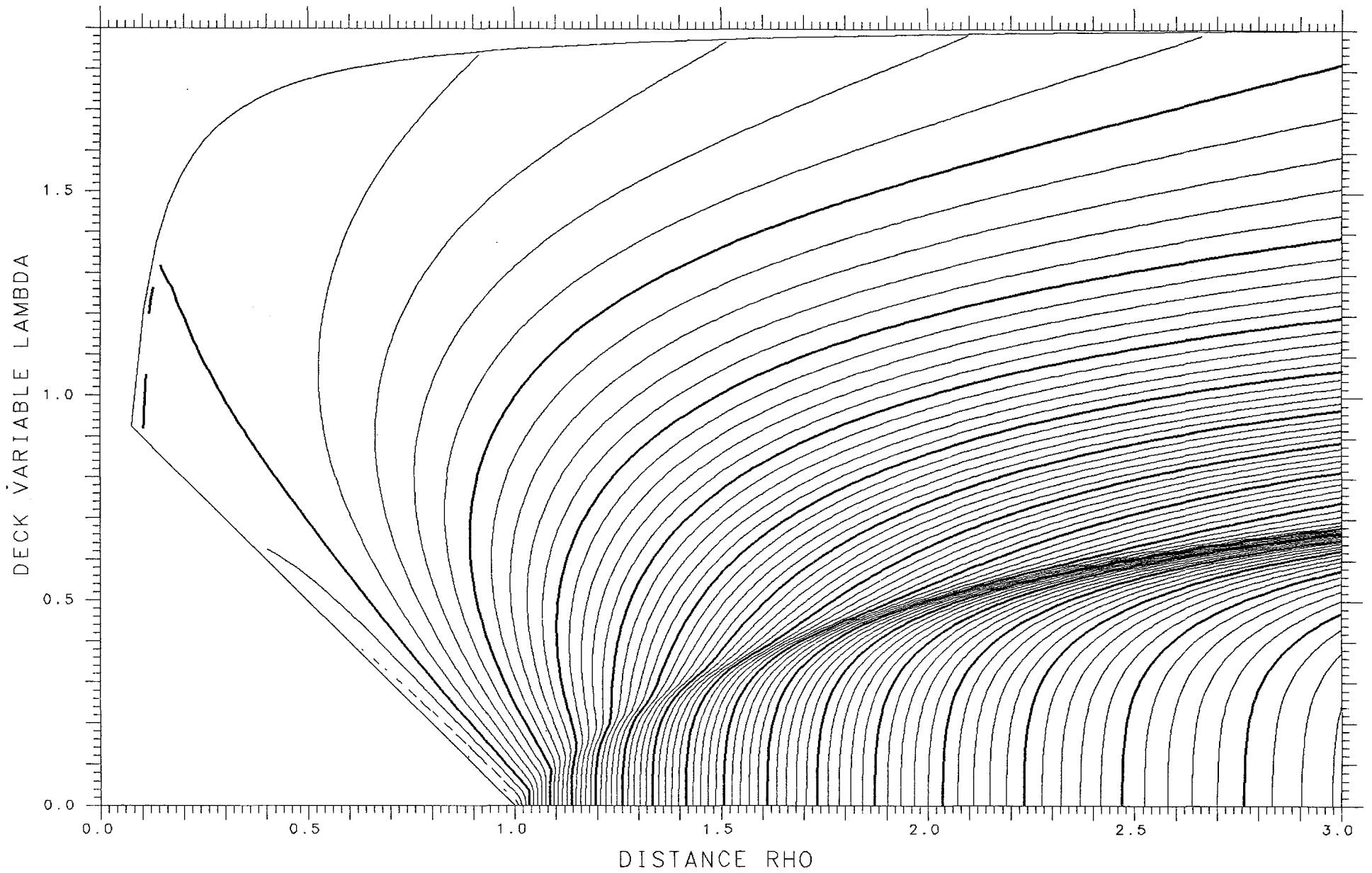

X= .200 ASYMMETRY DELTA= .275 FRACTIONAL= .8447

SPHERES .10238 TANGENT .16136 LENGTH 6.566 ENERGY 231.99 SPACING .005

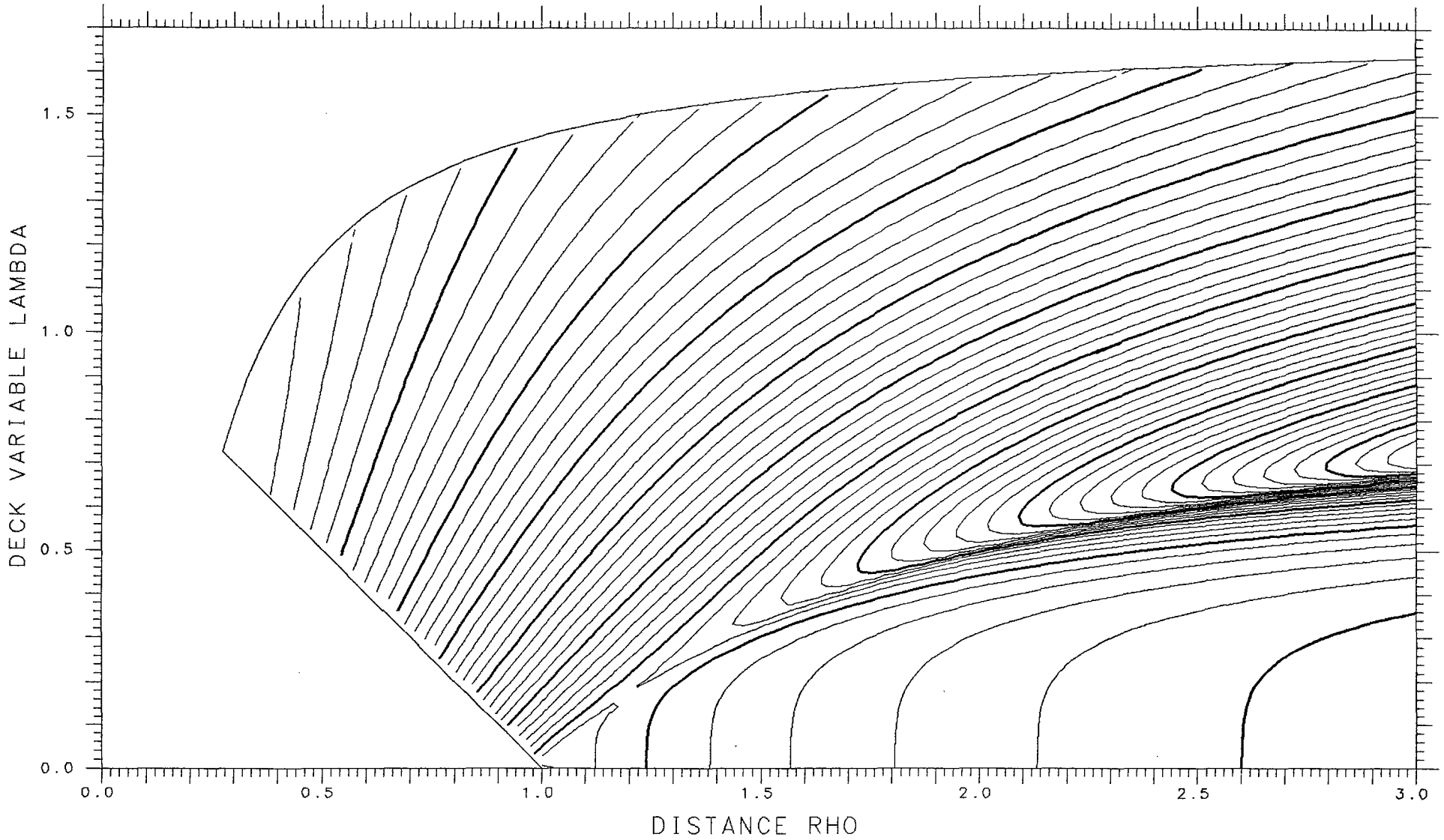

X=1.150

ASYMMETRY DELTA= .050

FRACTIONAL= .5745

SPHERES -.57641

TANGENT .01537

LENGTH 14.009

ENERGY 822.07

SPACING .005

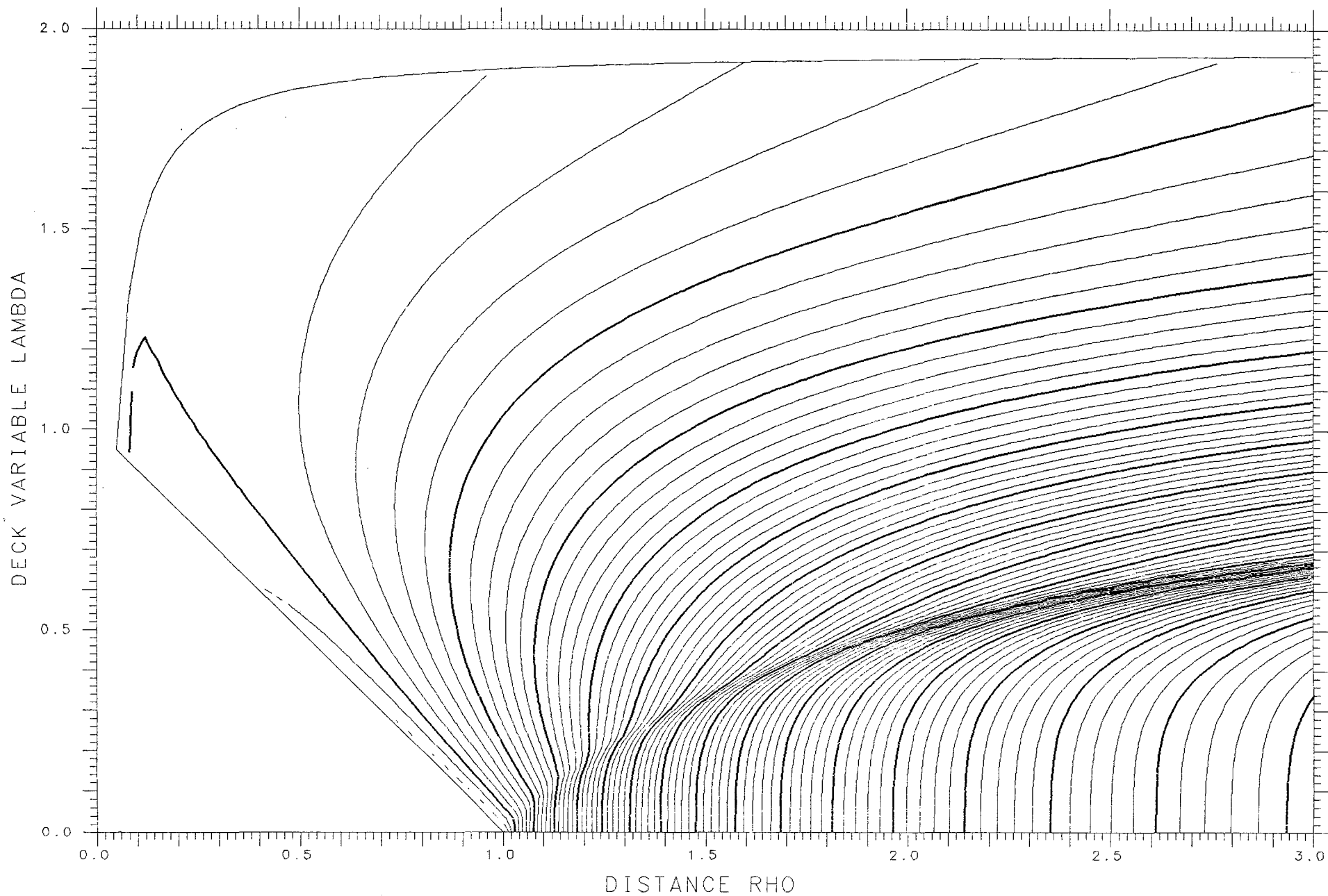

X= .200 ASYMMETRY DELTA= .300 FRACTIONAL= .8650

SPHERES .09934 TANGENT .15246 LENGTH 6.490 ENERGY 231.99 SPACING .005

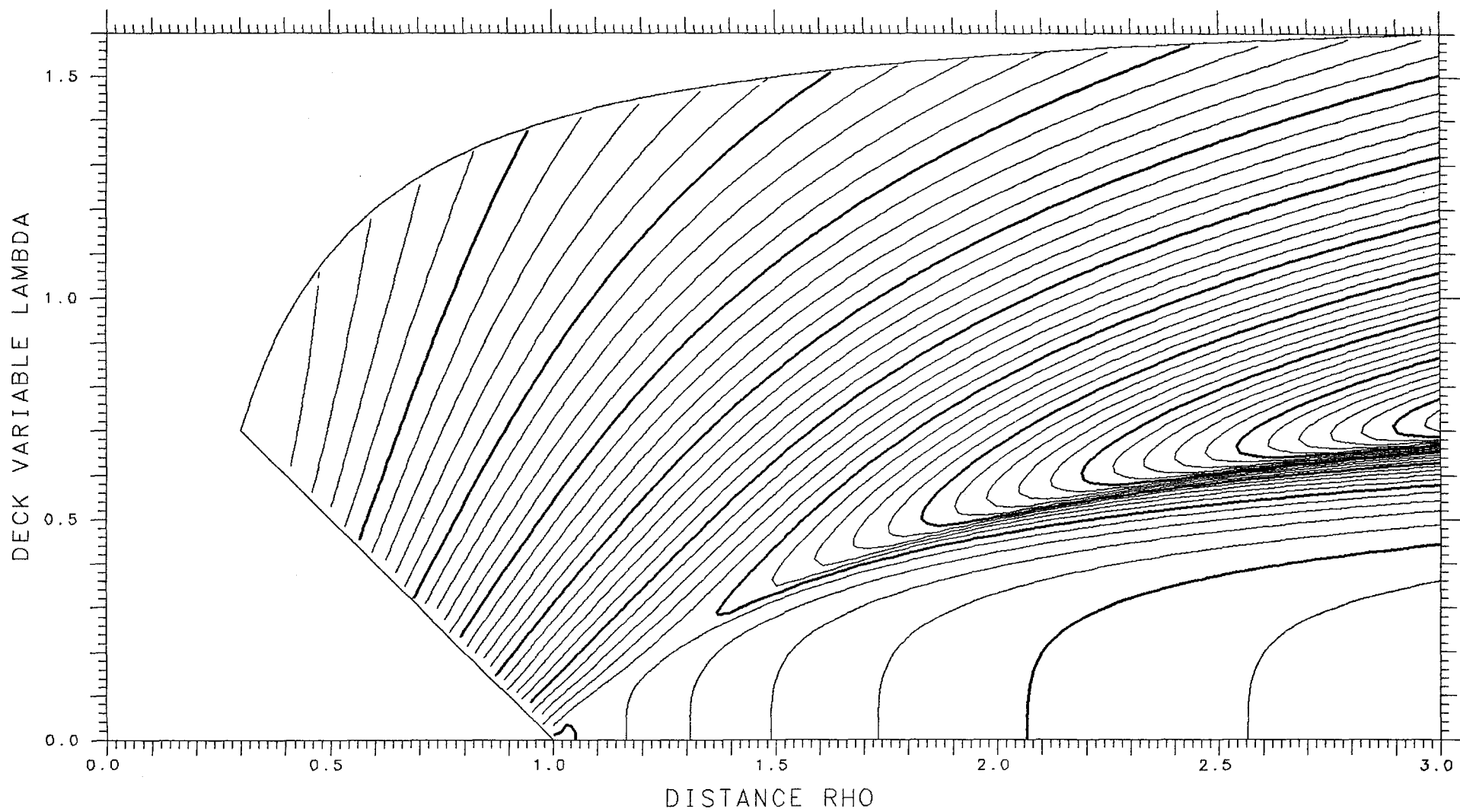

X=1.150

ASYMMETRY DELTA= .025

FRACTIONAL= .5374

SPHERES -.58744

TANGENT .01326

LENGTH 14.035

ENERGY 822.07

SPACING .005

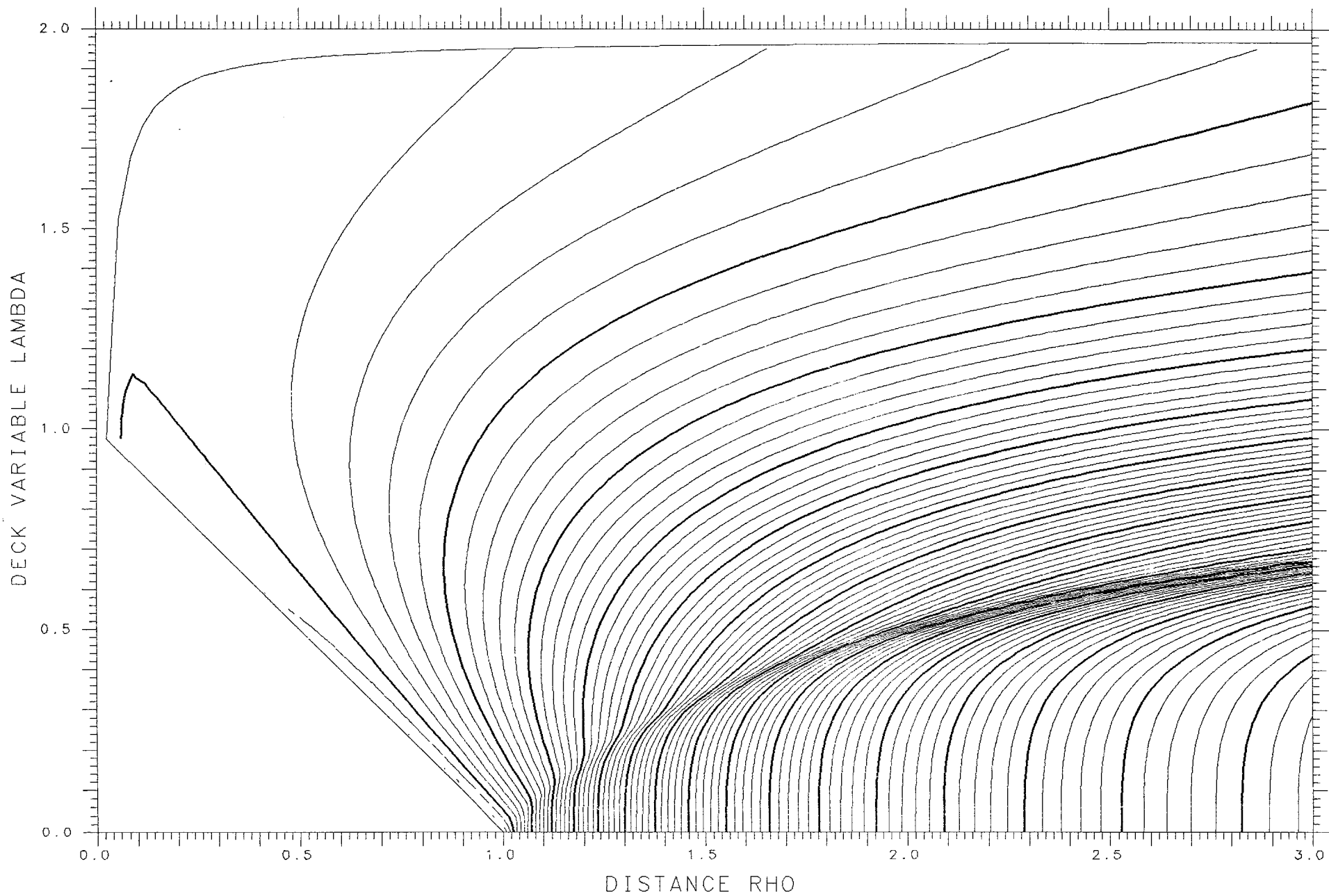

X= .200 ASYMMETRY DELTA= .325 FRACTIONAL= .8832

SPHERES .09584 TANGENT .14332 LENGTH 6.412 ENERGY 231.99 SPACING .005

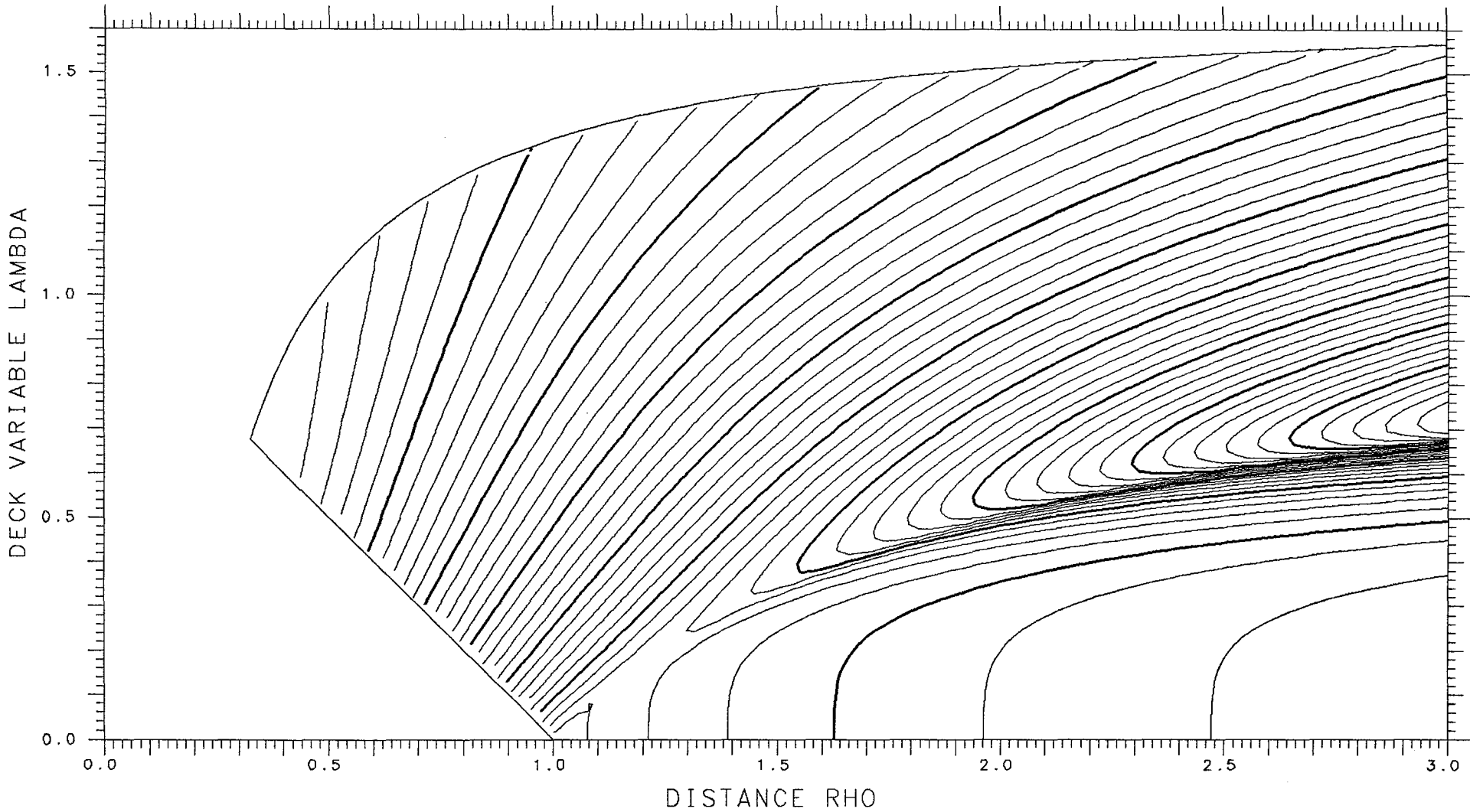

X=1.150

ASYMMETRY DELTA=0.

FRACTIONAL= .5000

SPHERES -.59117

TANGENT .01254

LENGTH 14.044

ENERGY 822.07

SPACING .005

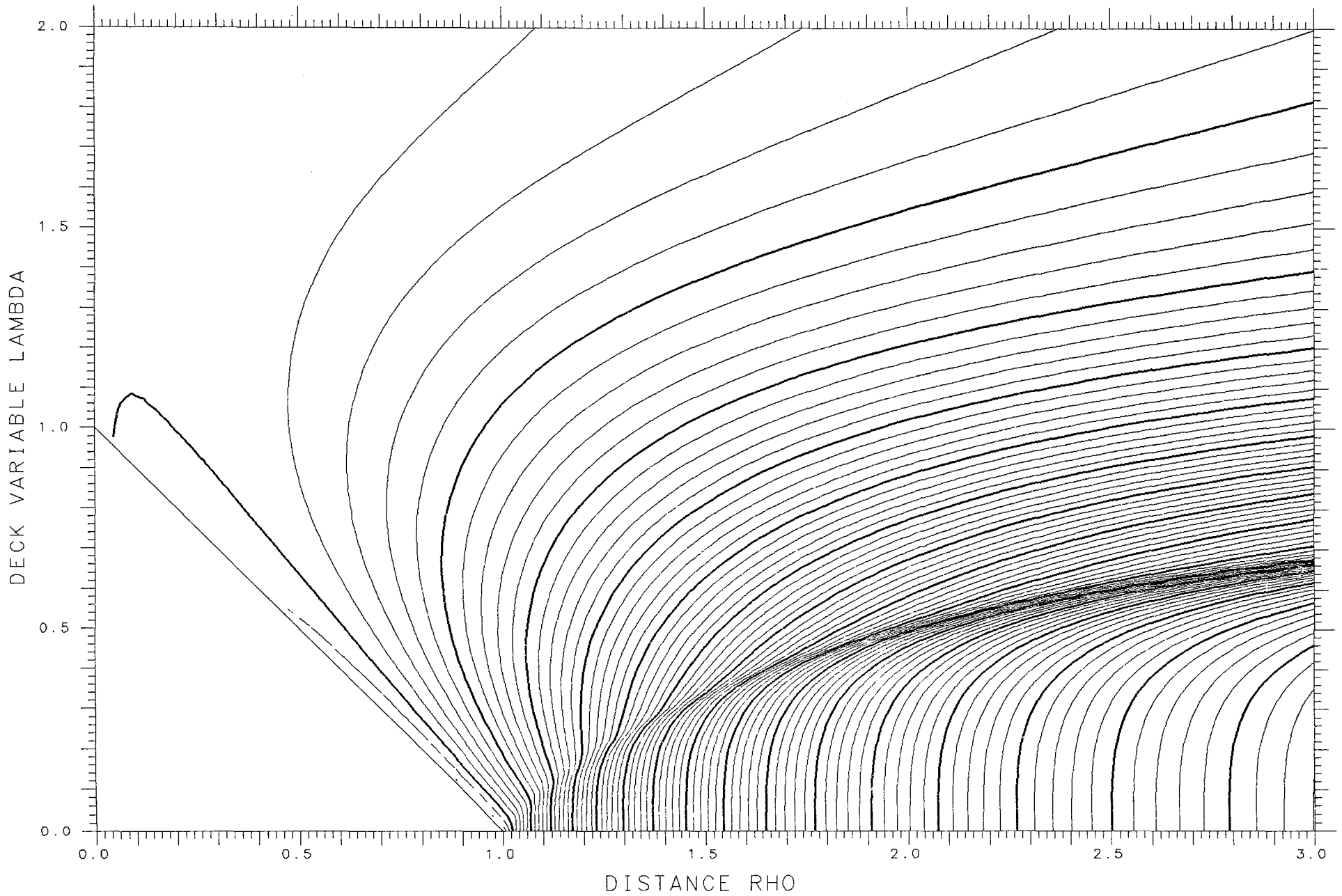

X= .200 ASYMMETRY DELTA= .350 FRACTIONAL= .8996

SPHERES .09192 TANGENT .13403 LENGTH 6.332 ENERGY 231.99 SPACING .005

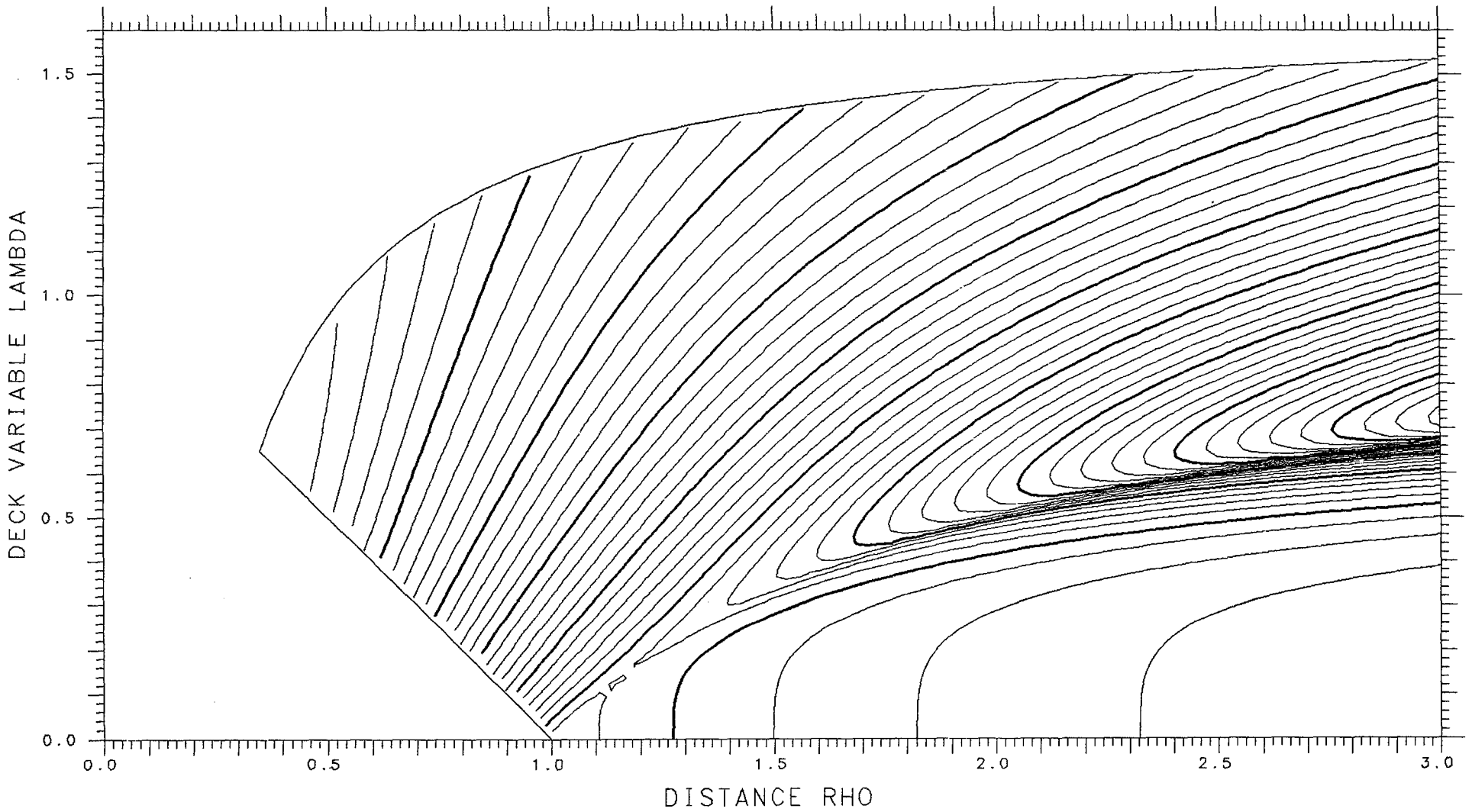

X=1.100 ASYMMETRY DELTA= .250 FRACTIONAL= .8224

SPHERES -.29469 TANGENT .06262 LENGTH 13.033 ENERGY 797.86 SPACING .005

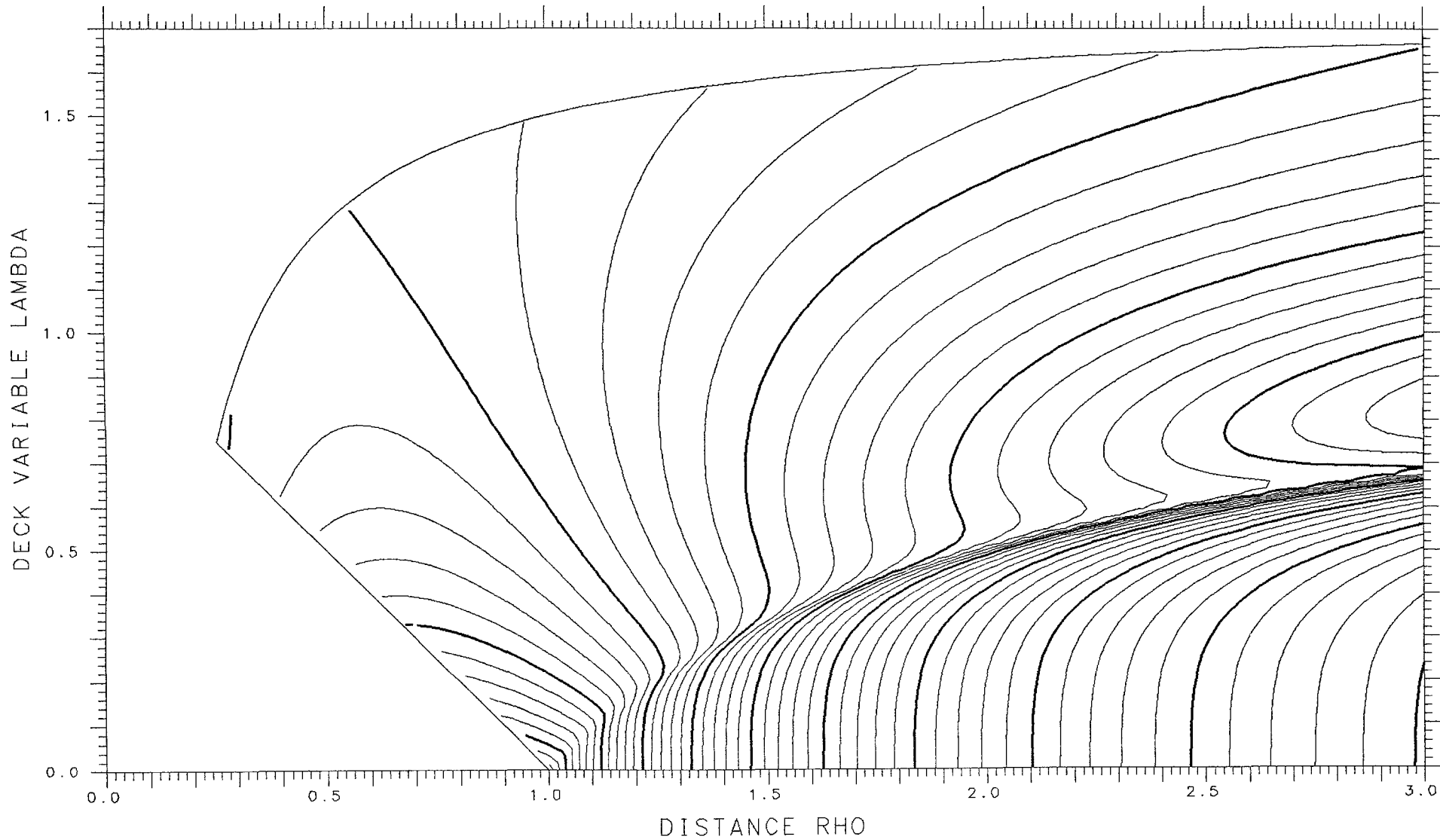

X= .200 ASYMMETRY DELTA= .375 FRACTIONAL= .9141

SPHERES .08763 TANGENT .12469 LENGTH 6.251 ENERGY 231.99 SPACING .005

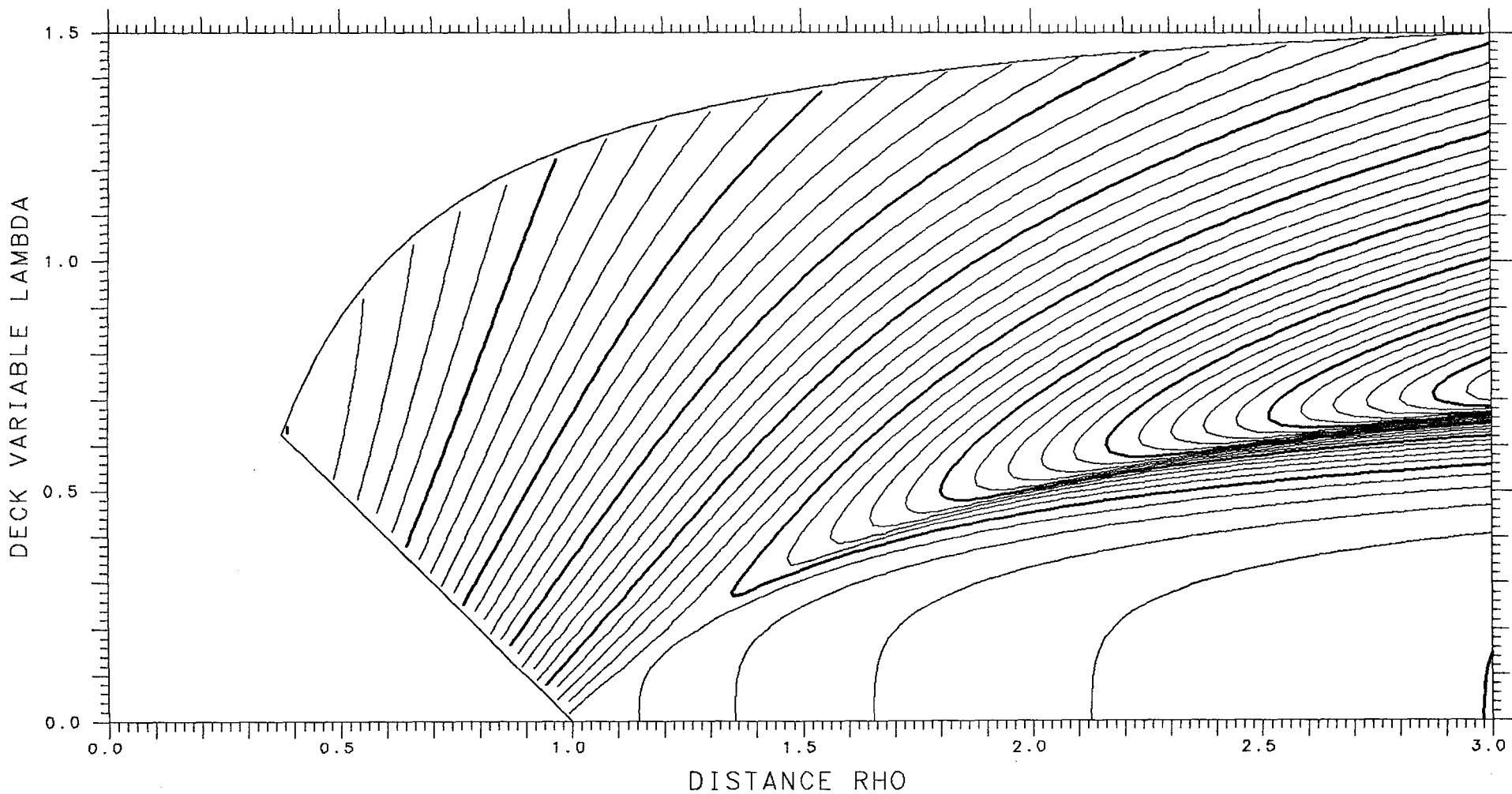

X=1.100

ASYMMETRY DELTA= .225

FRACTIONAL= .7979

SPHERES -.33207

TANGENT .05832

LENGTH 13.166

ENERGY 797.86

SPACING .005

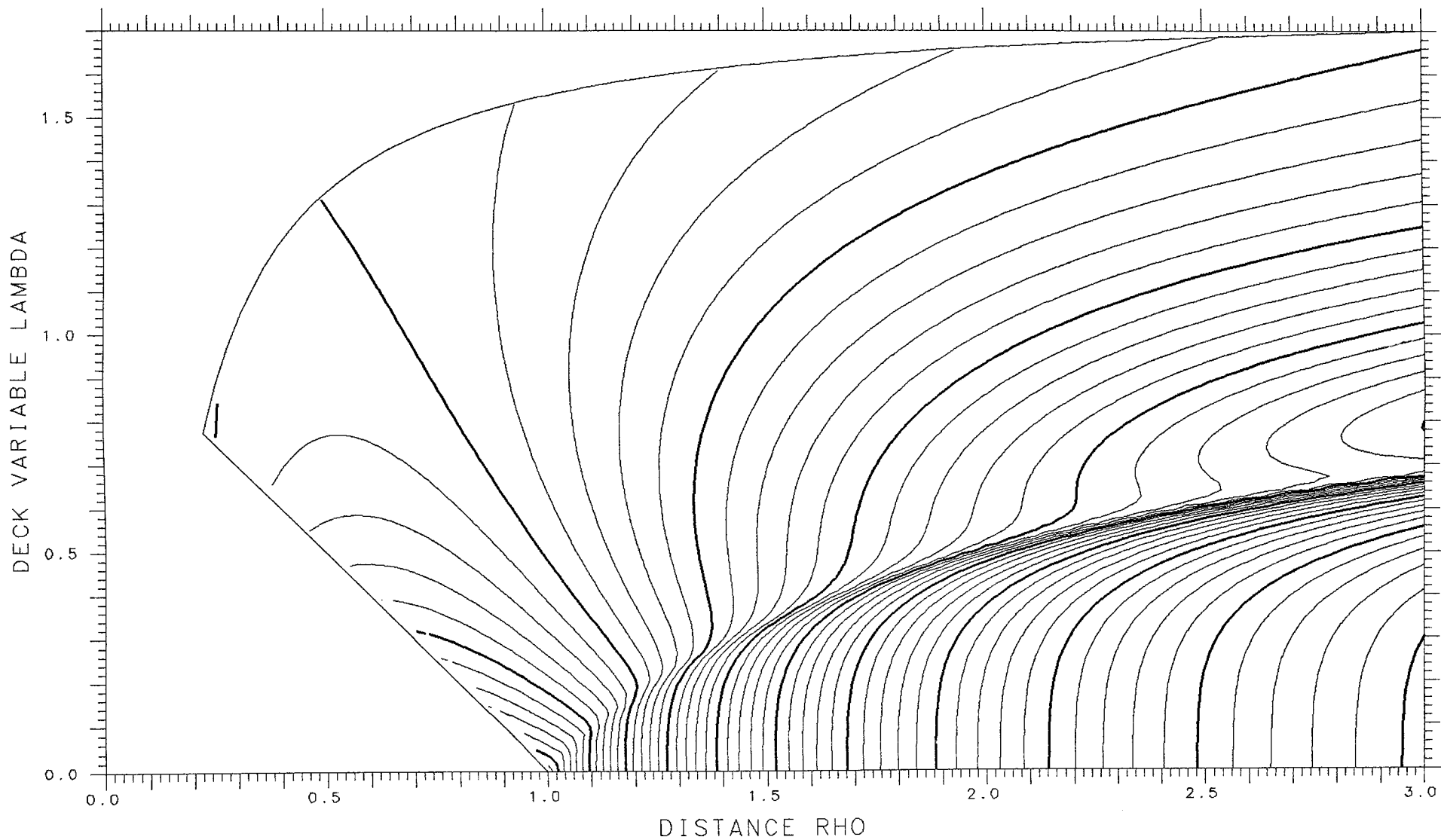

X= .250

ASYMMETRY DELTA=0.

FRACTIONAL= .5000

SPHERES .07490

TANGENT .20614

LENGTH 7.653

ENERGY 273.58

SPACING .005

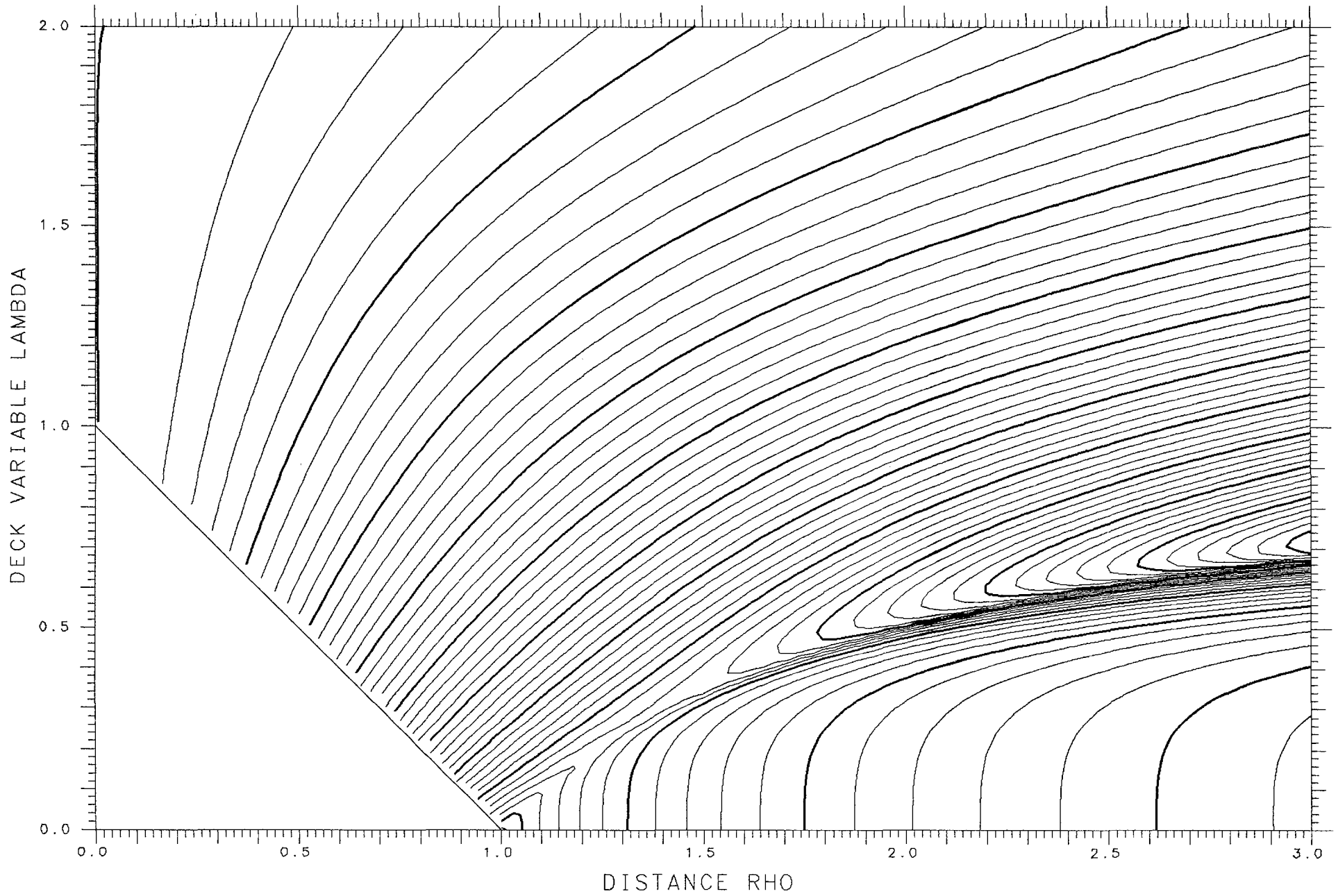

X=1.100

ASYMMETRY DELTA= .200

FRACTIONAL= .7714

SPHERES -.36953

TANGENT .05344

LENGTH 13.290

ENERGY 797.86

SPACING .005

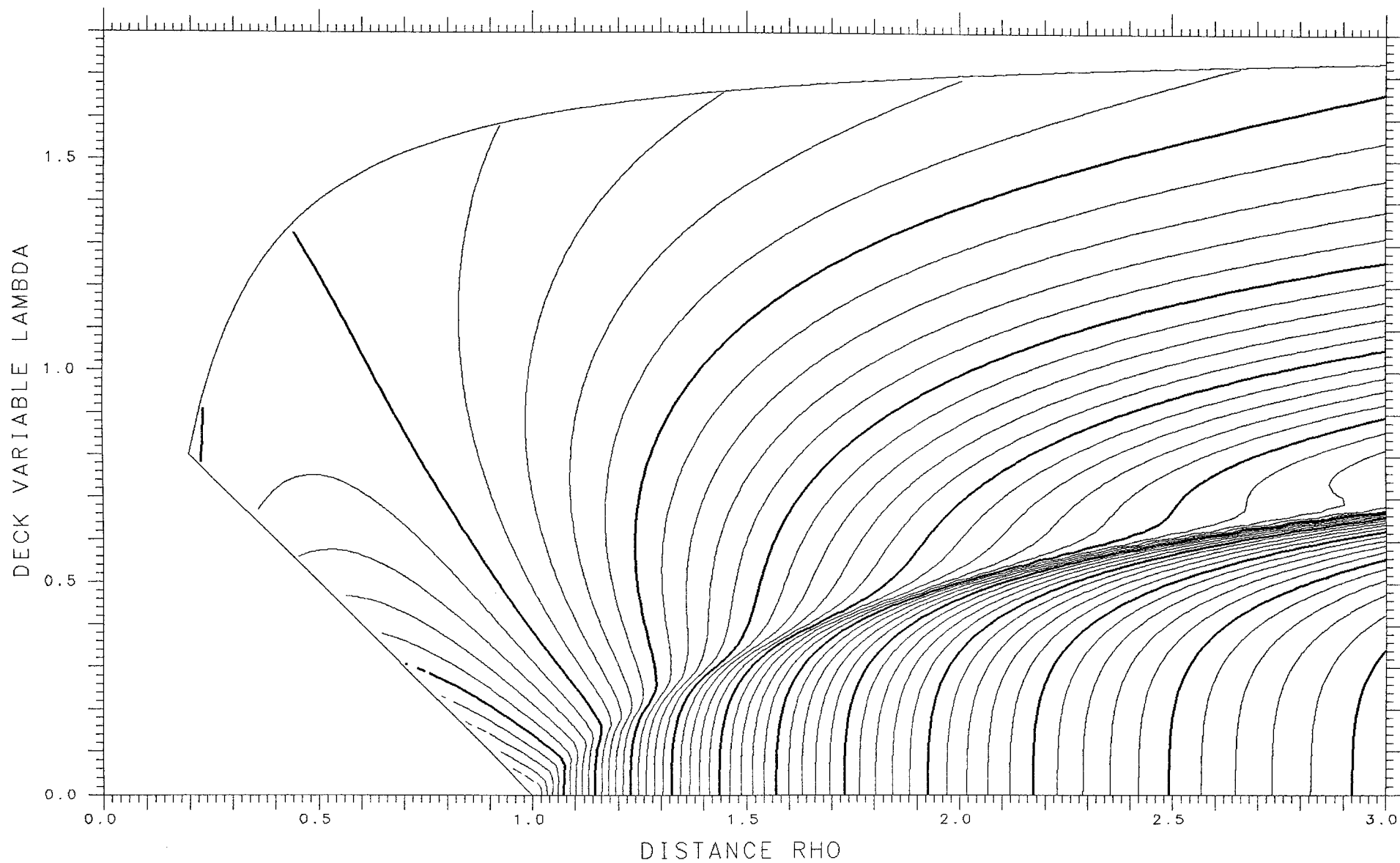

X= .250 ASYMMETRY DELTA= .025 FRACTIONAL= .5374

SPHERES .07510 TANGENT .20568 LENGTH 7.648 ENERGY 273.58 SPACING .005

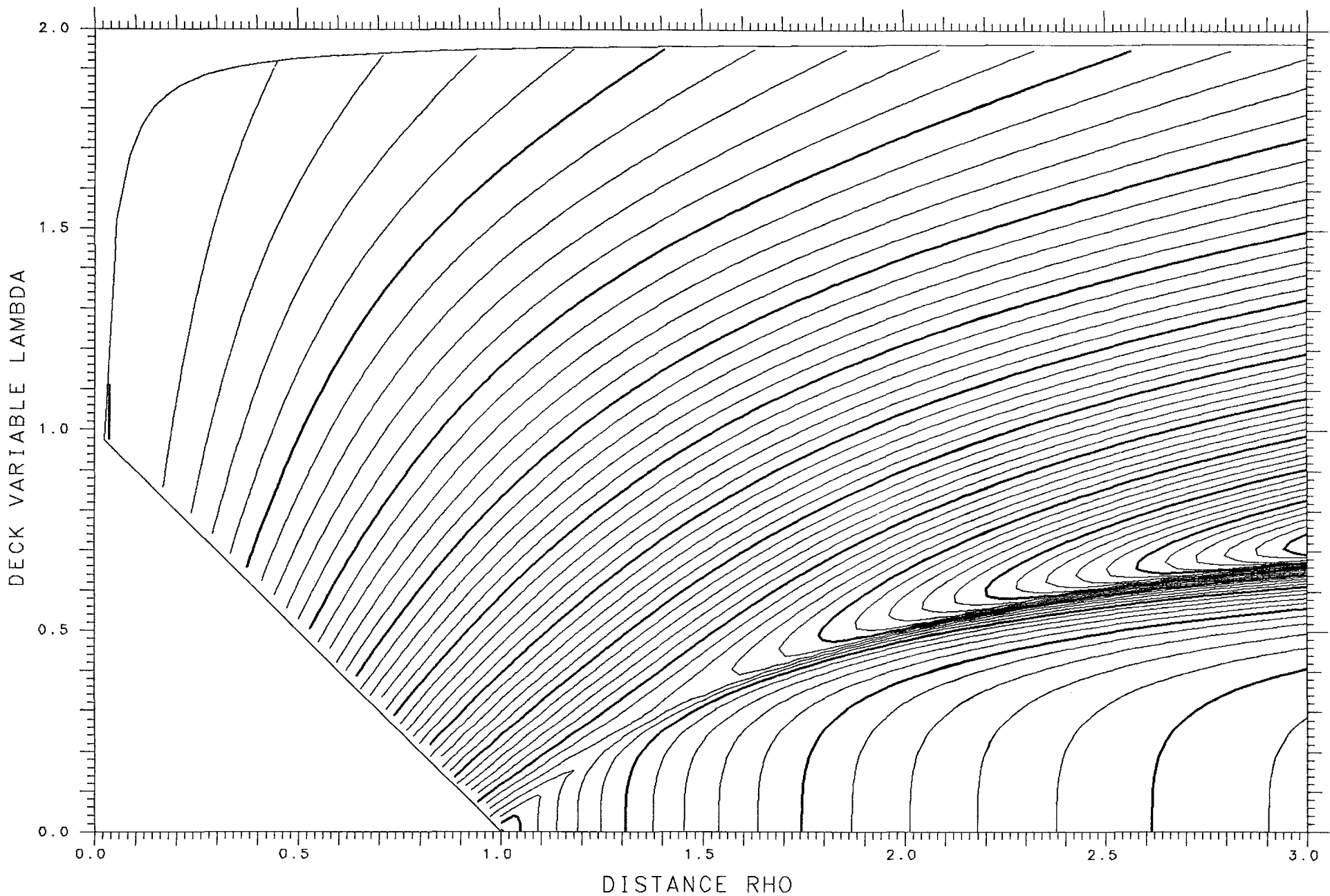

X=1.100 ASYMMETRY DELTA= .175 FRACTIONAL= .7429

SPHERES -.40613 TANGENT .04821 LENGTH 13.403 ENERGY 797.86 SPACING .005

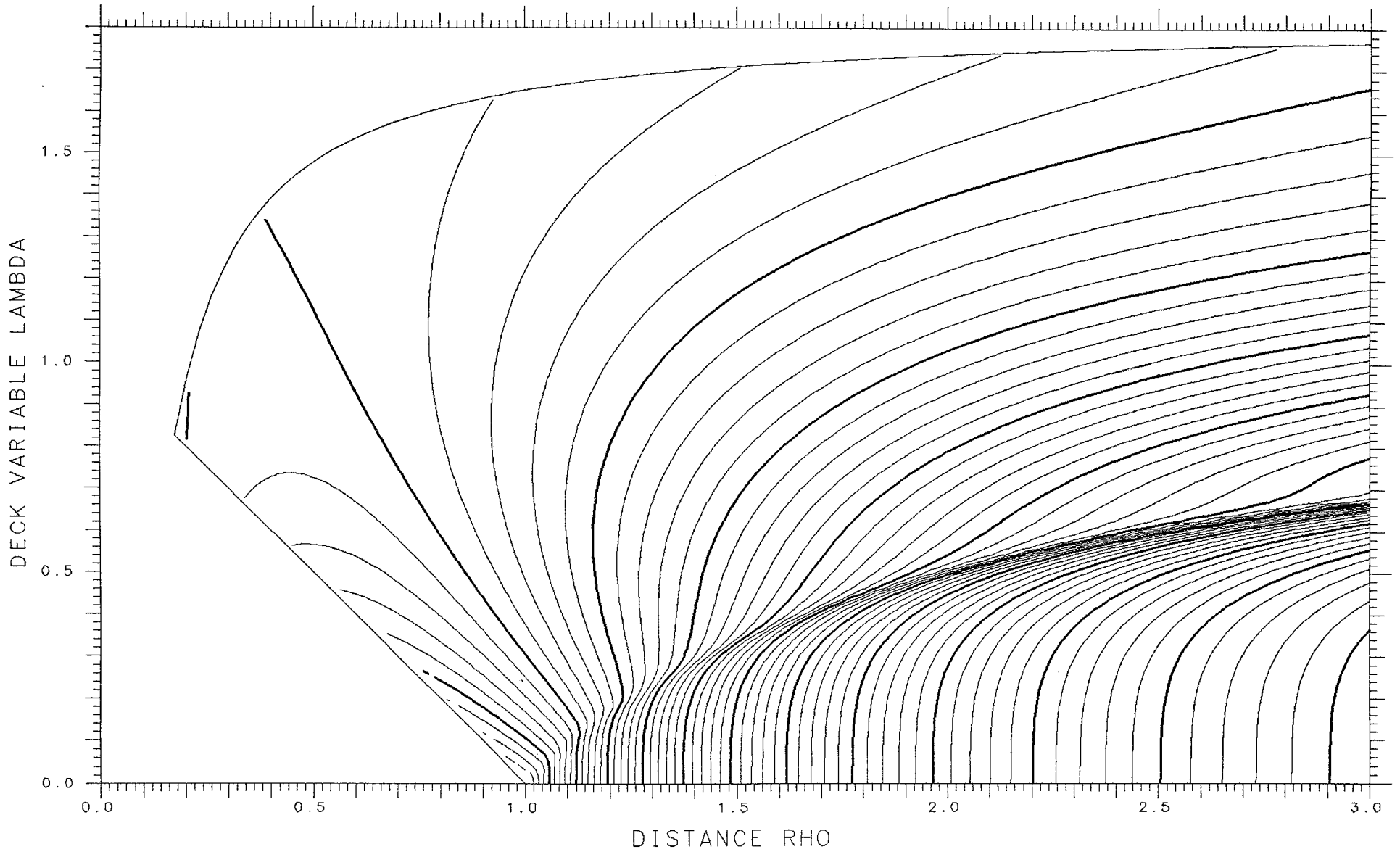

X= .250 ASYMMETRY DELTA= .050 FRACTIONAL= .5745

SPHERES .07566 TANGENT .20431 LENGTH 7.634 ENERGY 273.58 SPACING .005

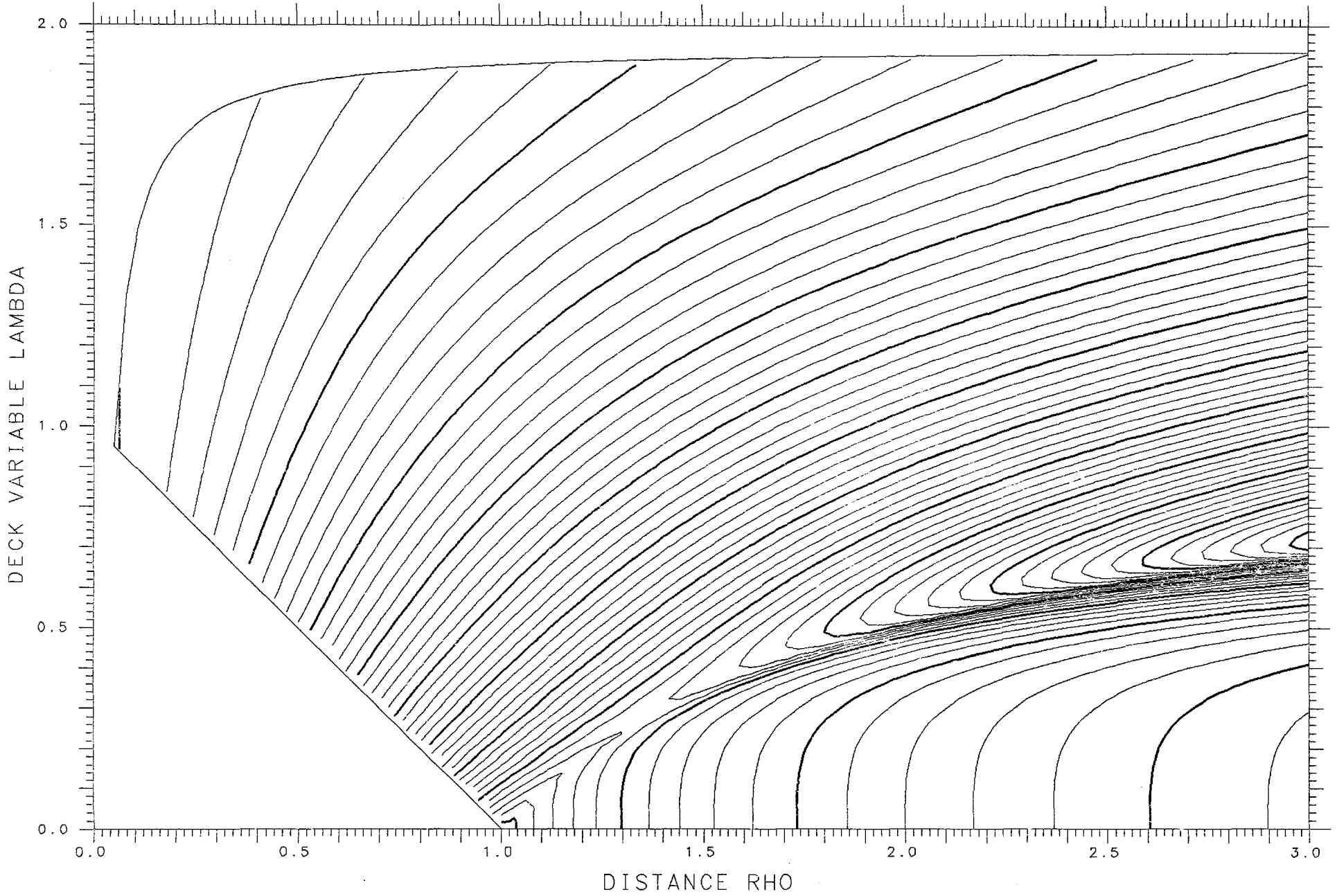

X=1.100

ASYMMETRY DELTA= .150

FRACTIONAL= .7124

SPHERES -.44086

TANGENT .04286

LENGTH 13.504

ENERGY 797.86

SPACING .005

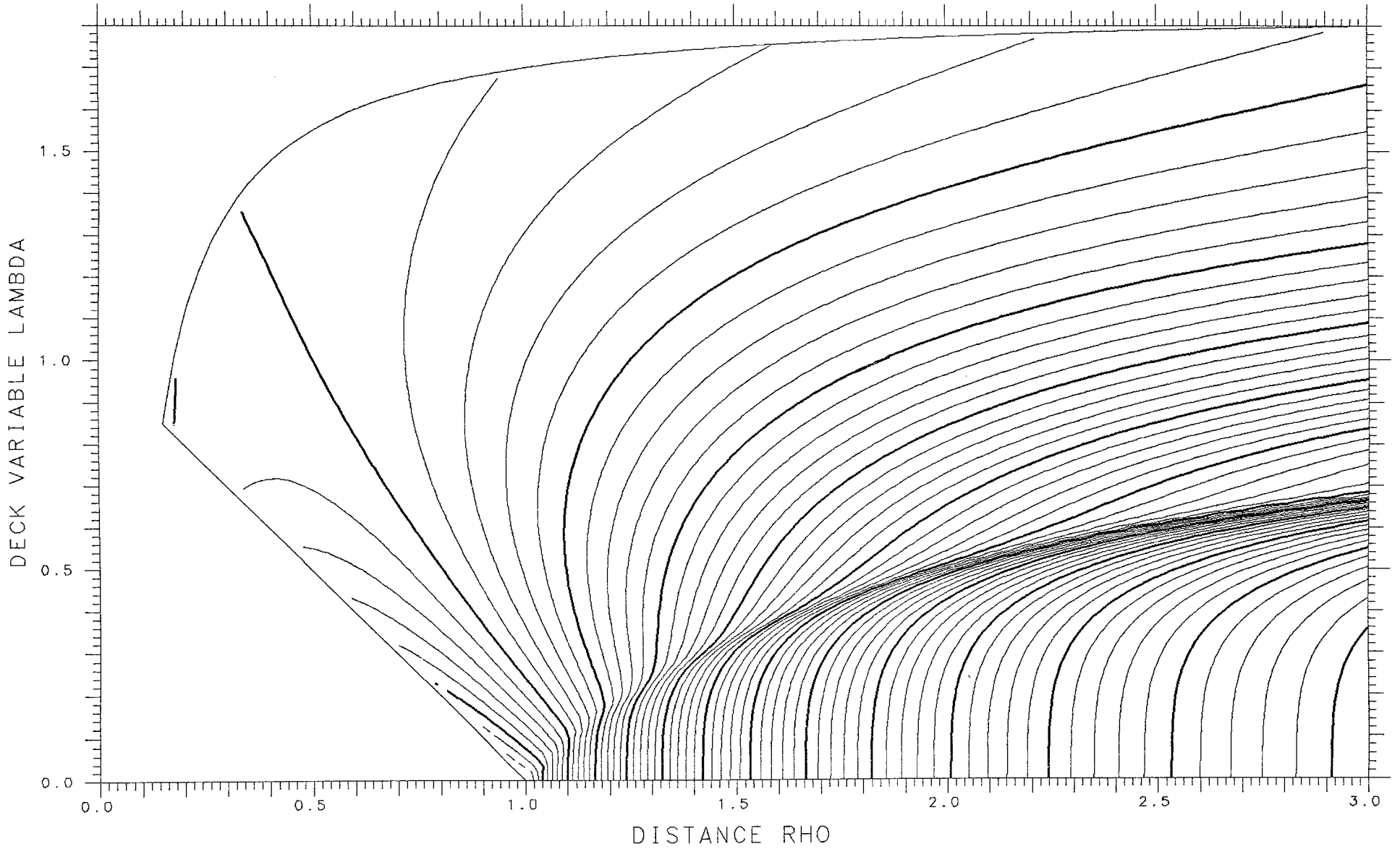

X= .250

ASYMMETRY DELTA= .075

FRACTIONAL= .6108

SPHERES .07655

TANGENT .20204

LENGTH 7.610

ENERGY 273.58

SPACING .005

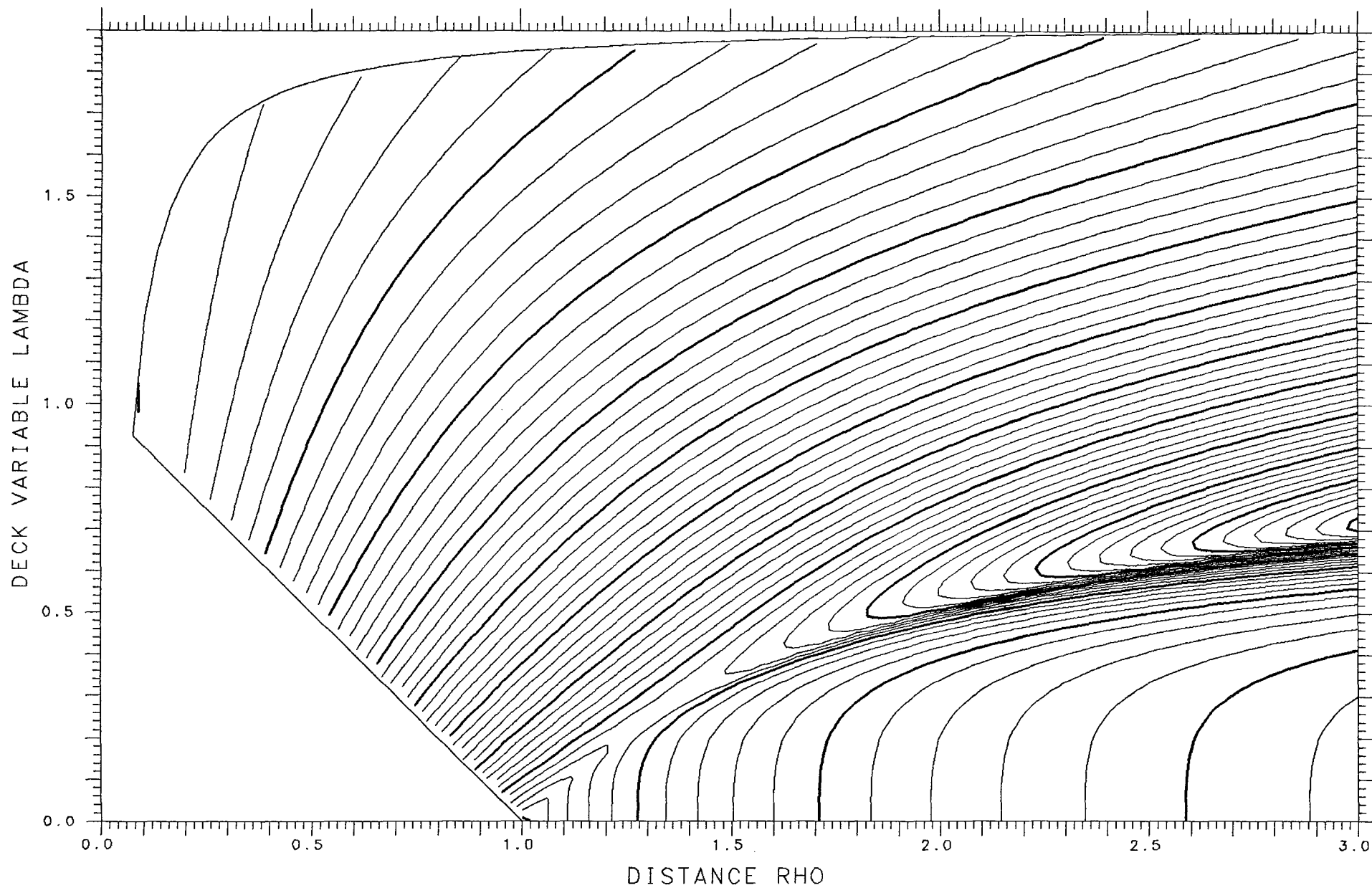

X=1.100

ASYMMETRY DELTA= .125

FRACTIONAL= .6800

SPHERES -.47264

TANGENT .03768

LENGTH 13.592

ENERGY 797.86

SPACING .005

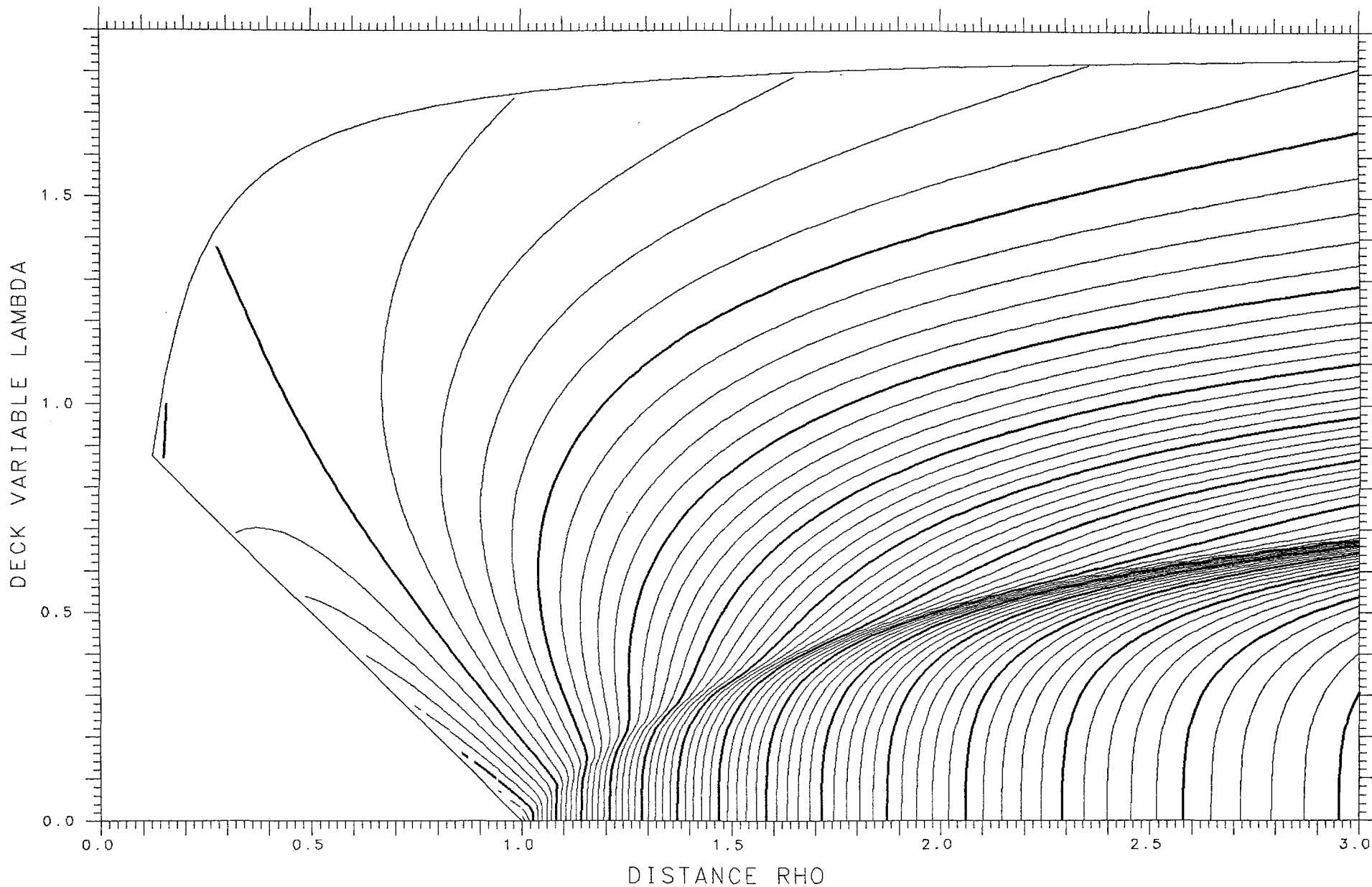

X= .250 ASYMMETRY DELTA= .100 FRACTIONAL= .6461

SPHERES .07766 TANGENT .19888 LENGTH 7.578 ENERGY 273.58 SPACING .005

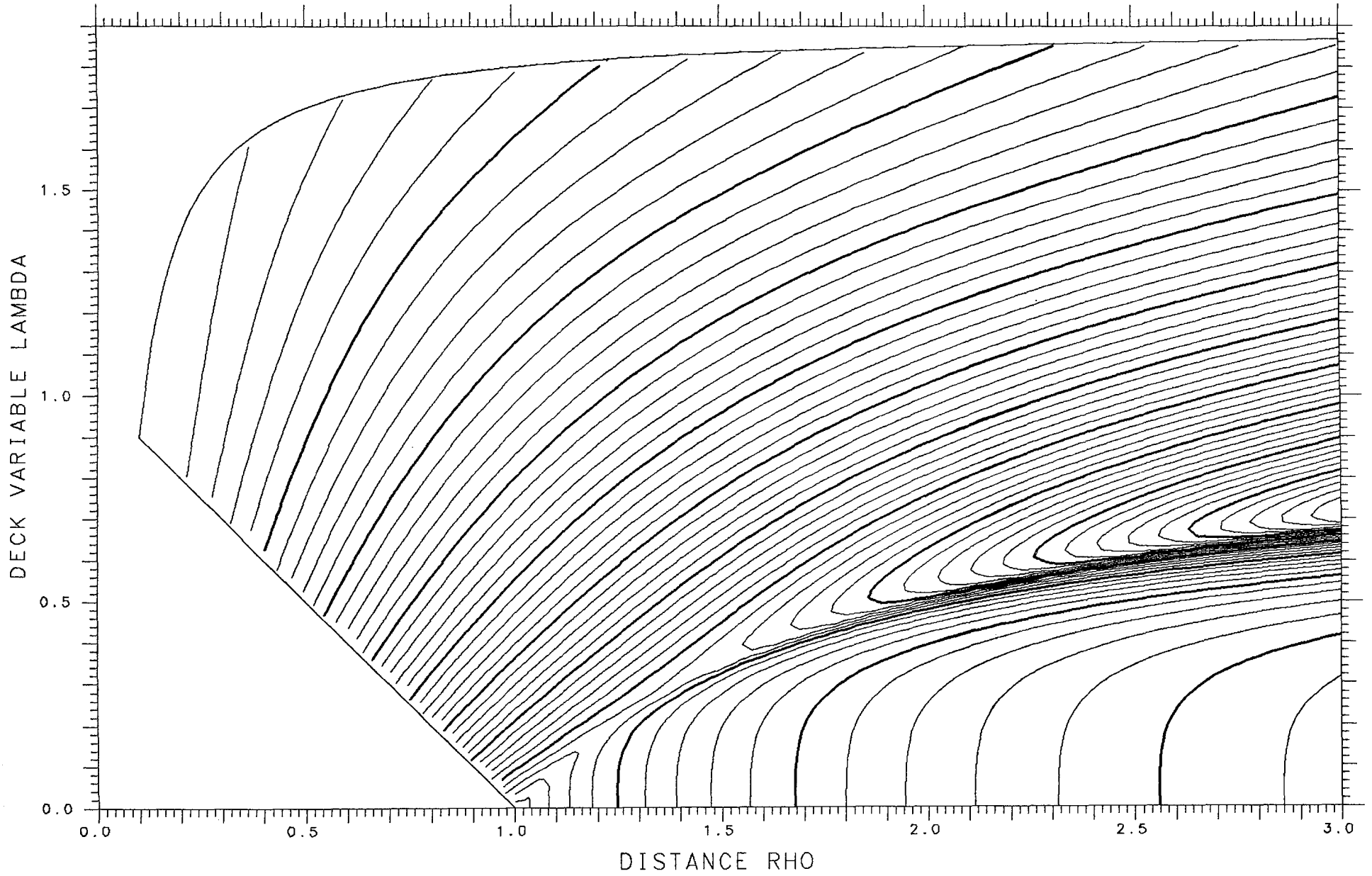

X=1.100 ASYMMETRY DELTA= .100 FRACTIONAL= .6461
SPHERES -.50043 TANGENT .03295 LENGTH 13.666 ENERGY 797.86 SPACING .005

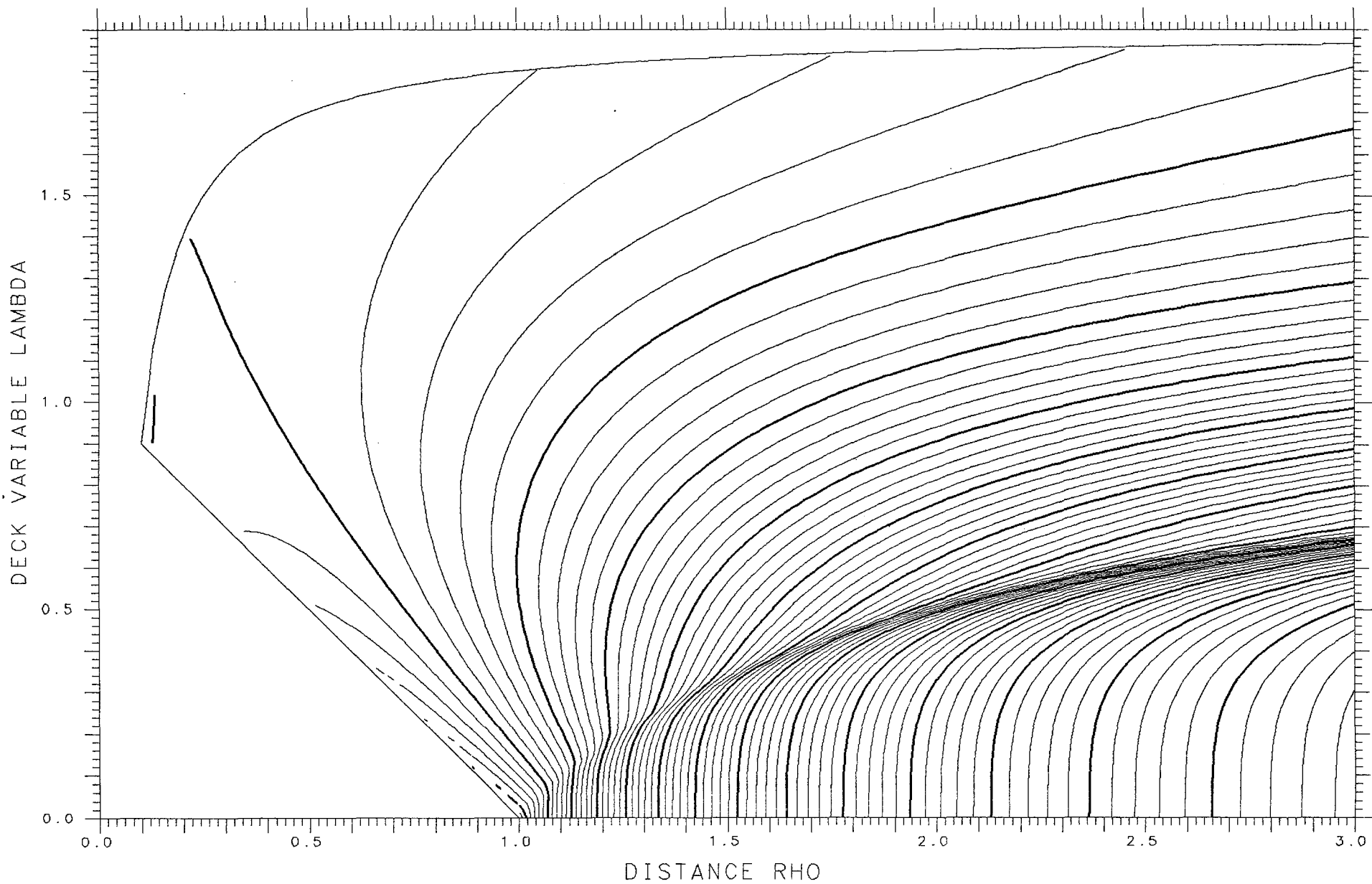

X= .250 ASYMMETRY DELTA= .125 FRACTIONAL= .6800

SPHERES .07890 TANGENT .19488 LENGTH 7.537 ENERGY 273.58 SPACING .005

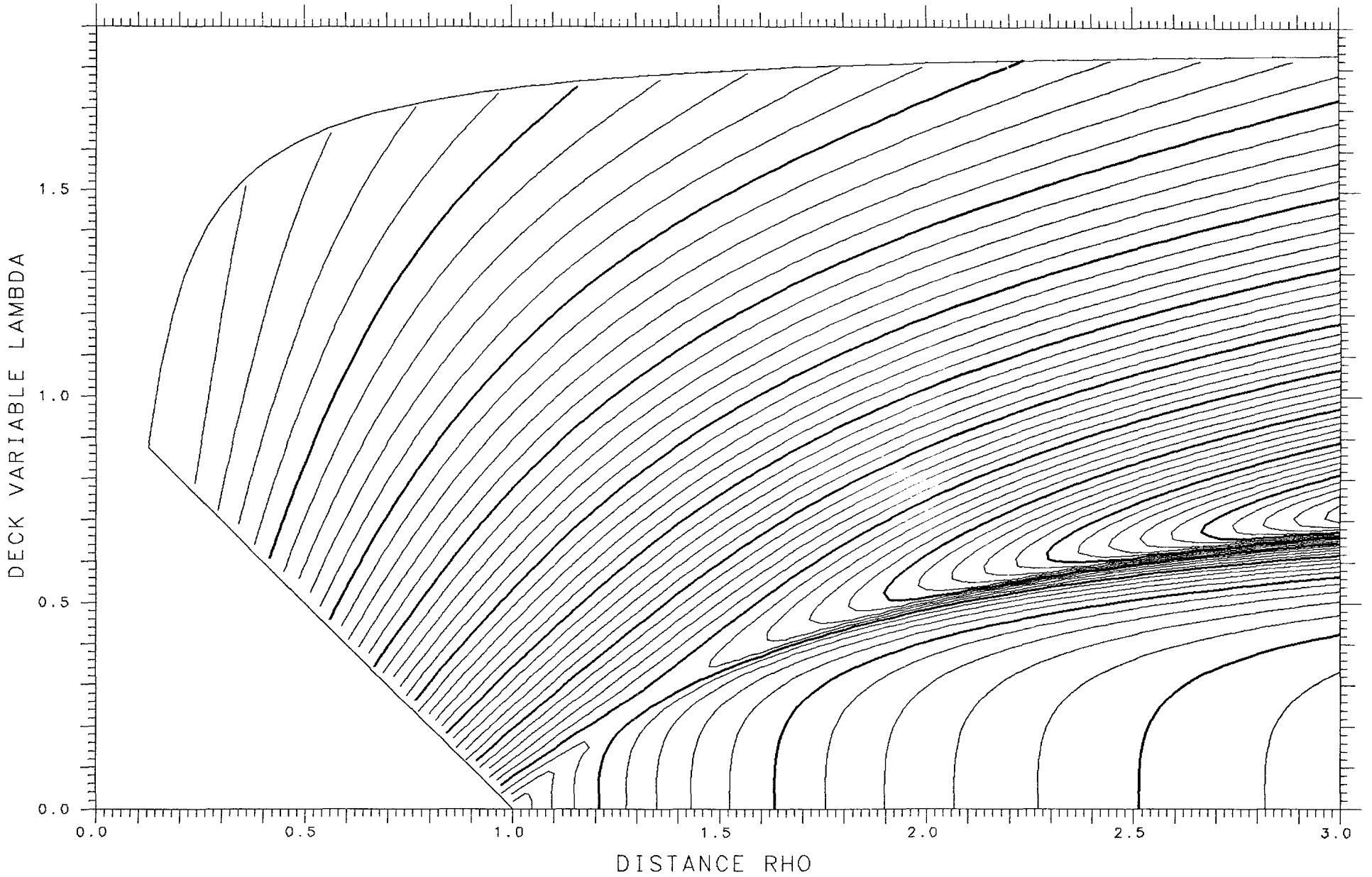

X=1.100

ASYMMETRY DELTA= .075

FRACTIONAL= .6108

SPHERES -.52323

TANGENT .02893

LENGTH 13.724

ENERGY 797.86

SPACING .005

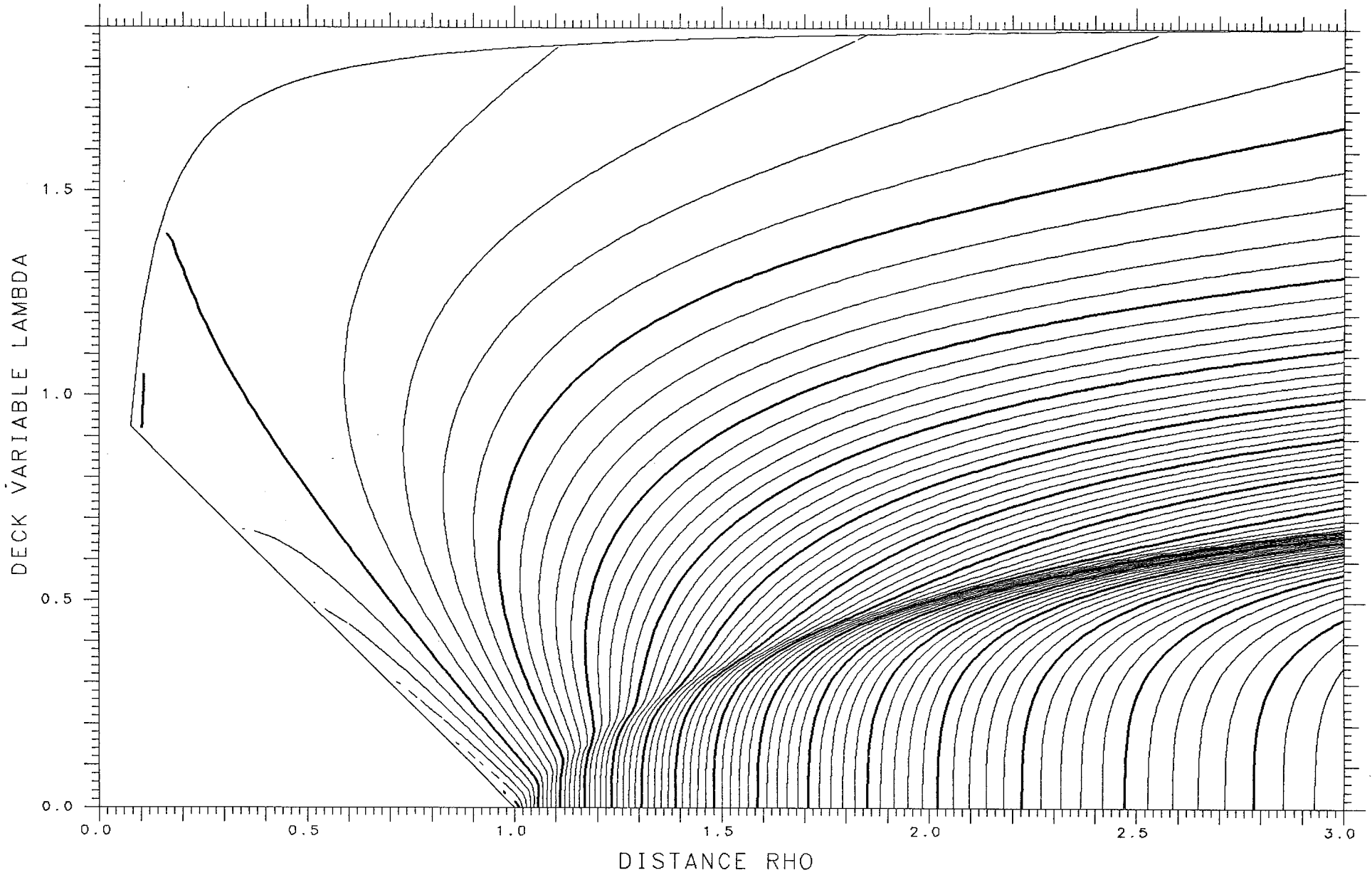

X= .250 ASYMMETRY DELTA= .150 FRACTIONAL= .7124

SPHERES .08014 TANGENT .19008 LENGTH 7.488 ENERGY 273.58 SPACING .005

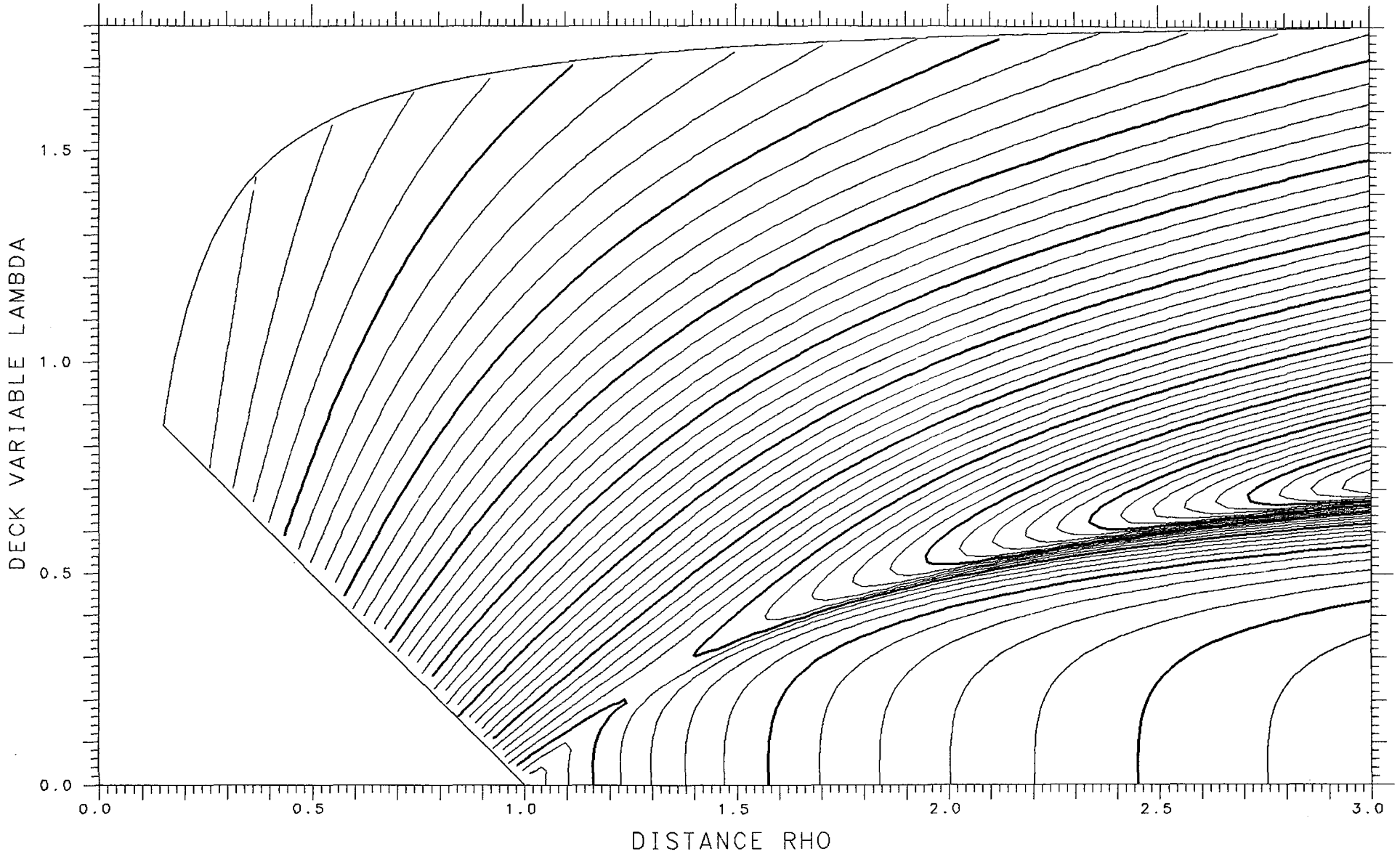

X=1.100 ASYMMETRY DELTA= .050 FRACTIONAL= .5745

SPHERES -.54018 TANGENT .02587 LENGTH 13.767 ENERGY 797.86 SPACING .005

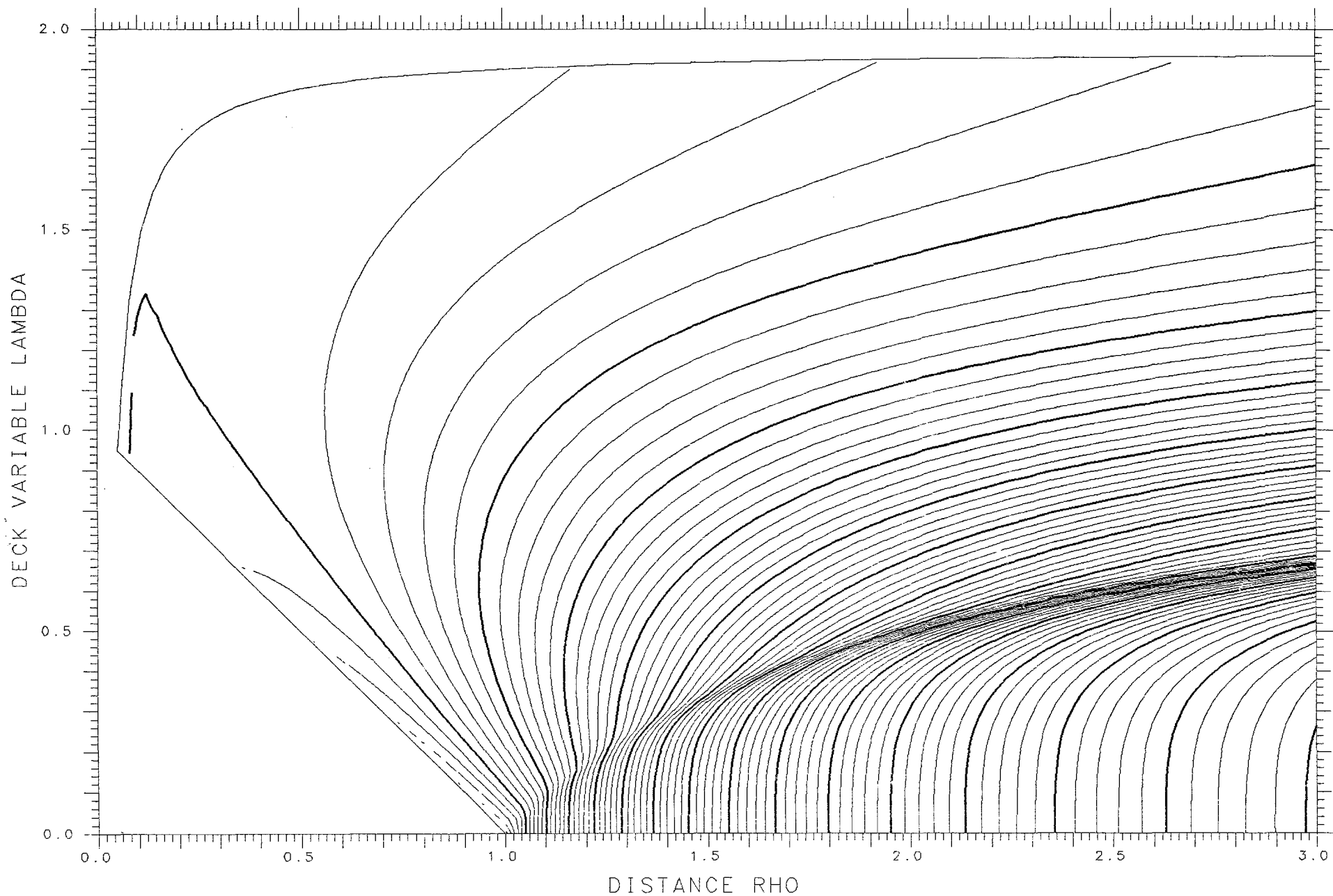

X= .250 ASYMMETRY DELTA= .175 FRACTIONAL= .7429

SPHERES .08126 TANGENT .18451 LENGTH 7.432 ENERGY 273.58 SPACING .005

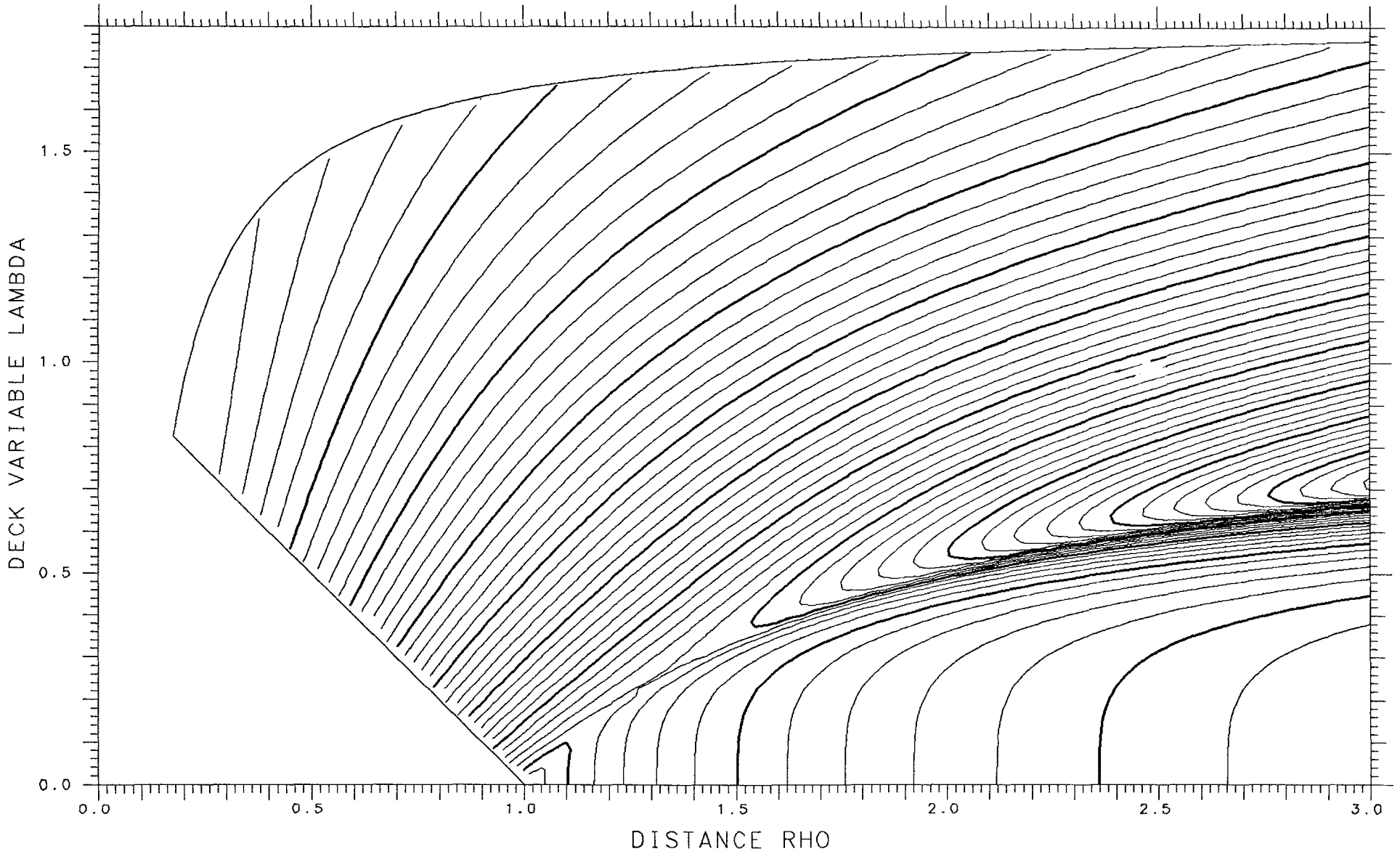

X=1.100

ASYMMETRY DELTA= .025

FRACTIONAL= .5374

SPHERES -.55063

TANGENT .02395

LENGTH 13.793

ENERGY 797.86

SPACING .005

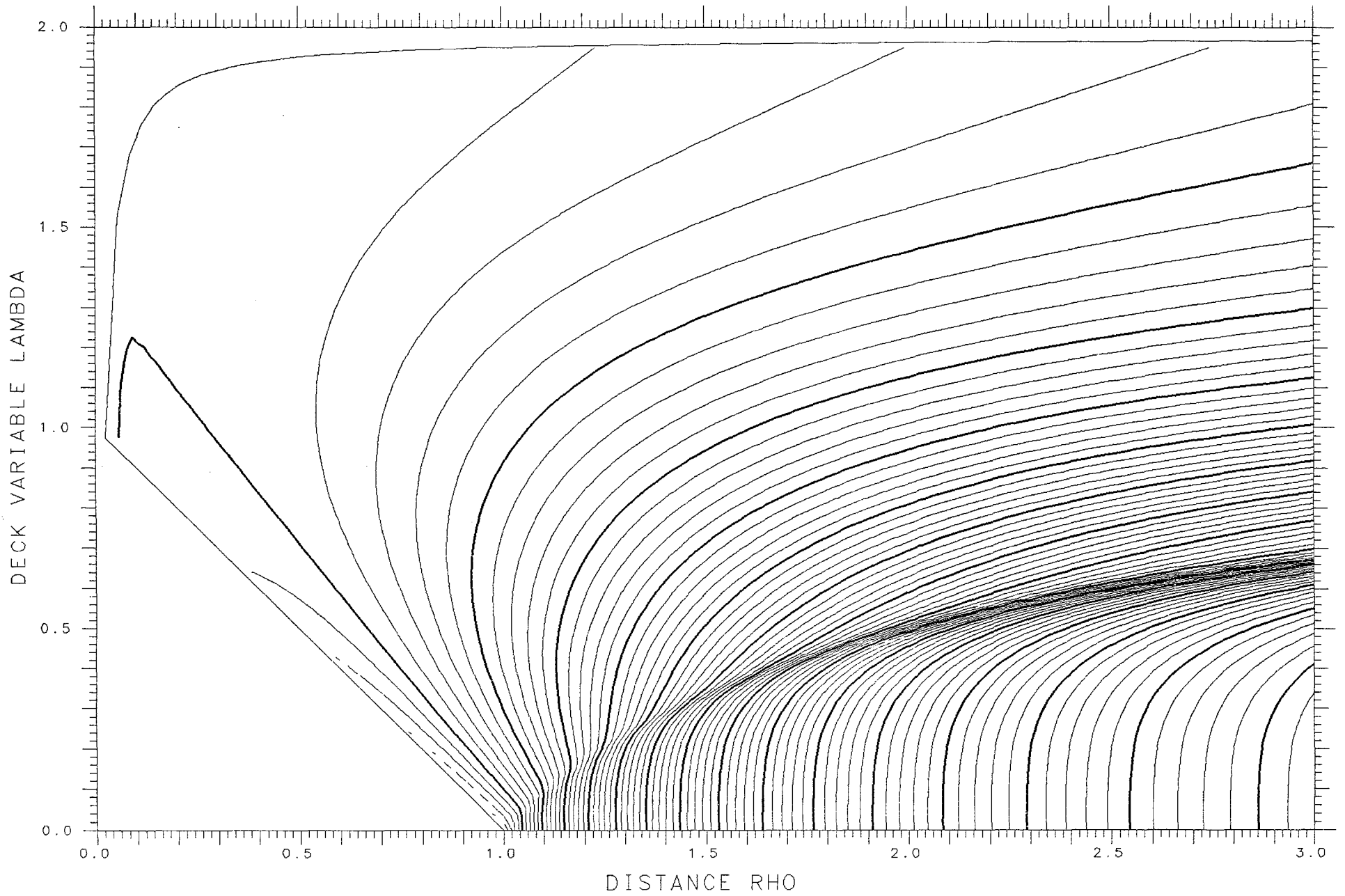

X= .250 ASYMMETRY DELTA= .200 FRACTIONAL= .7714
SPHERES .08213 TANGENT .17826 LENGTH 7.369 ENERGY 273.58 SPACING .005

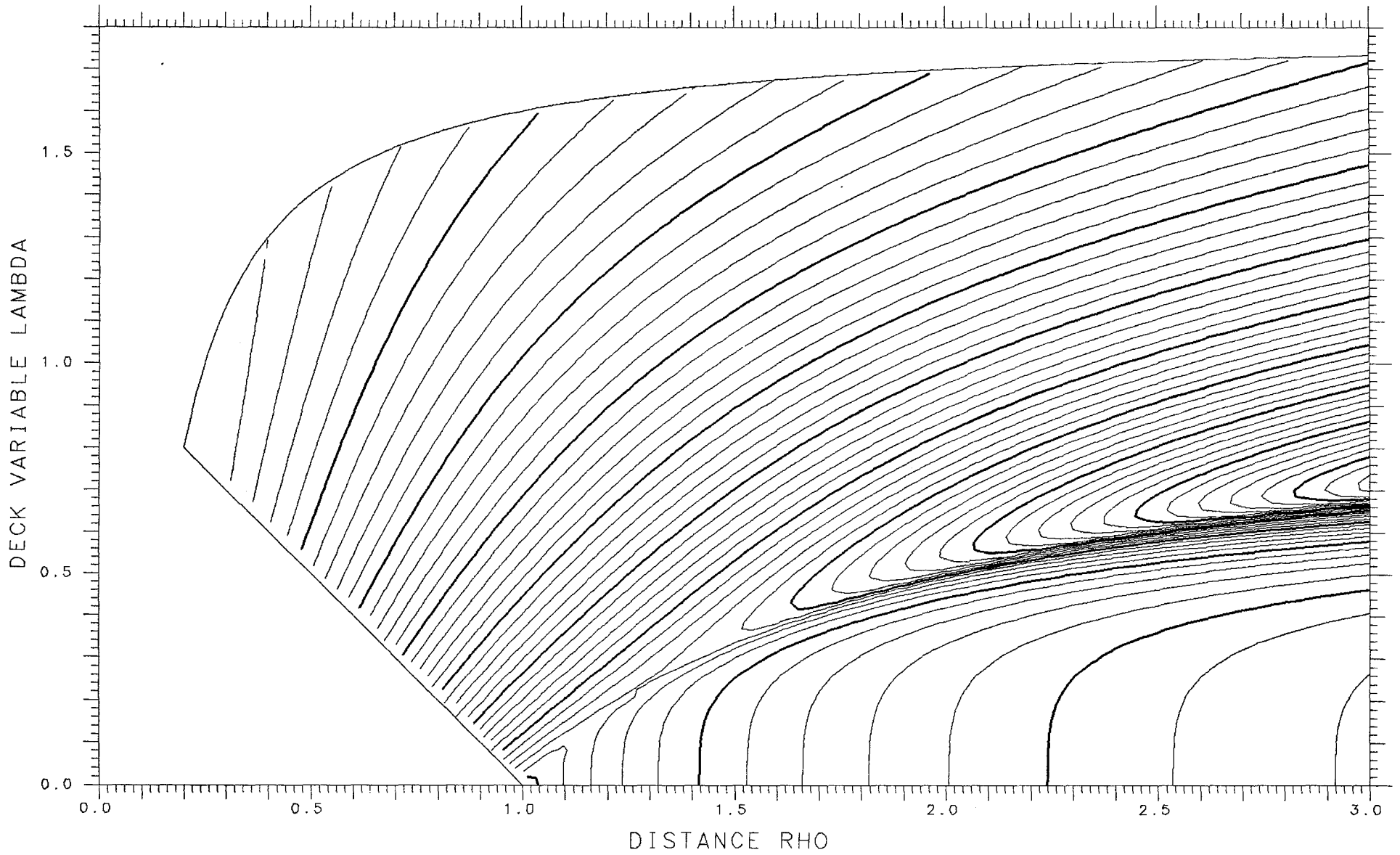

X=1.100

ASYMMETRY DELTA=0.

FRACTIONAL= .5000

SPHERES -.55417

TANGENT .02330

LENGTH 13.801

ENERGY 797.86

SPACING .005

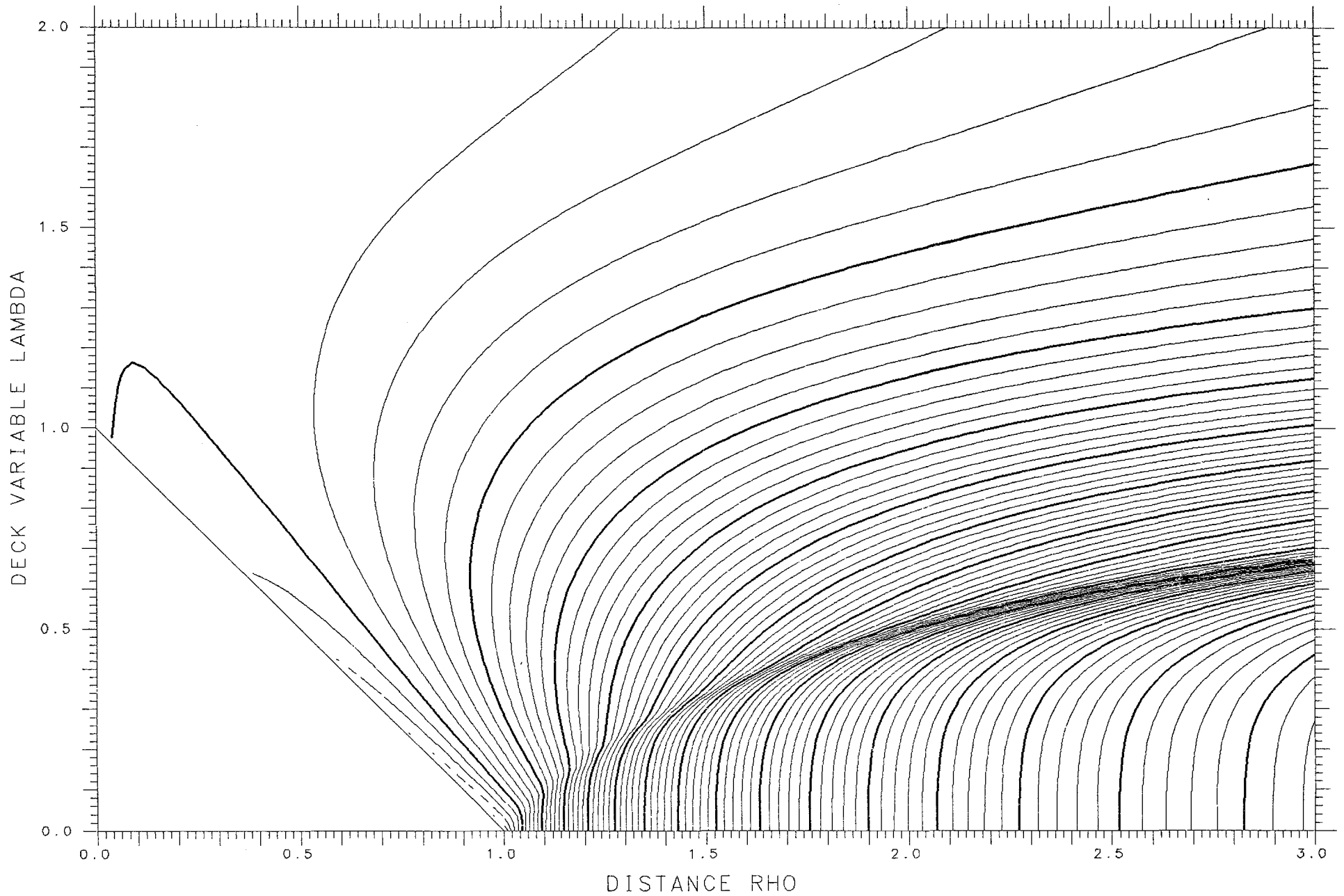

X= .250 ASYMMETRY DELTA= .225 FRACTIONAL= .7979

SPHERES .08265 TANGENT .17138 LENGTH 7.300 ENERGY 273.58 SPACING .005

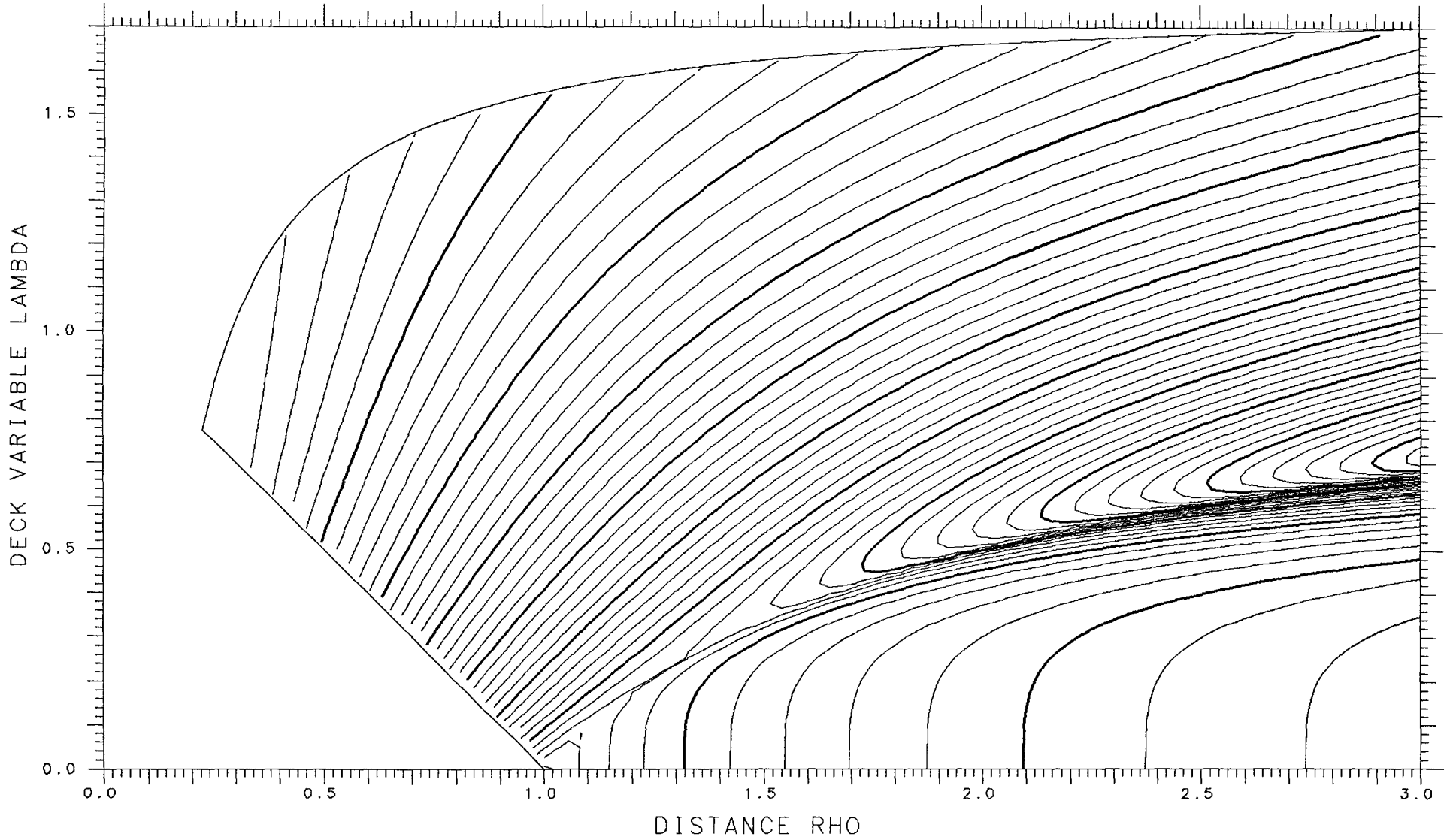

X=1.050 ASYMMETRY DELTA= .325 FRACTIONAL= .8832

SPHERES -.17454 TANGENT .07472 LENGTH 12.363 ENERGY 773.18 SPACING .005

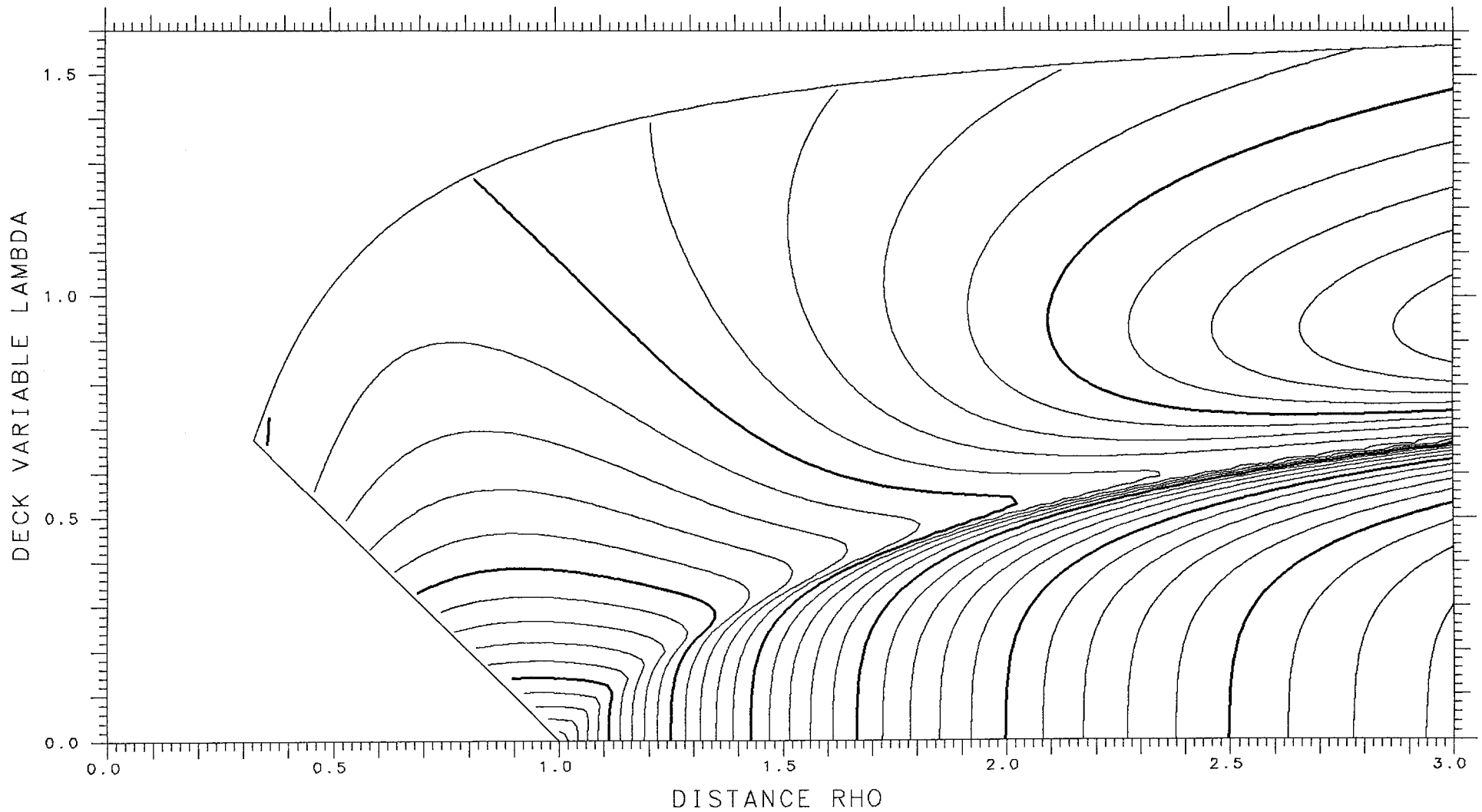

X= .250 ASYMMETRY DELTA= .250 FRACTIONAL= .8224

SPHERES .08275 TANGENT .16395 LENGTH 7.226 ENERGY 273.58 SPACING .005

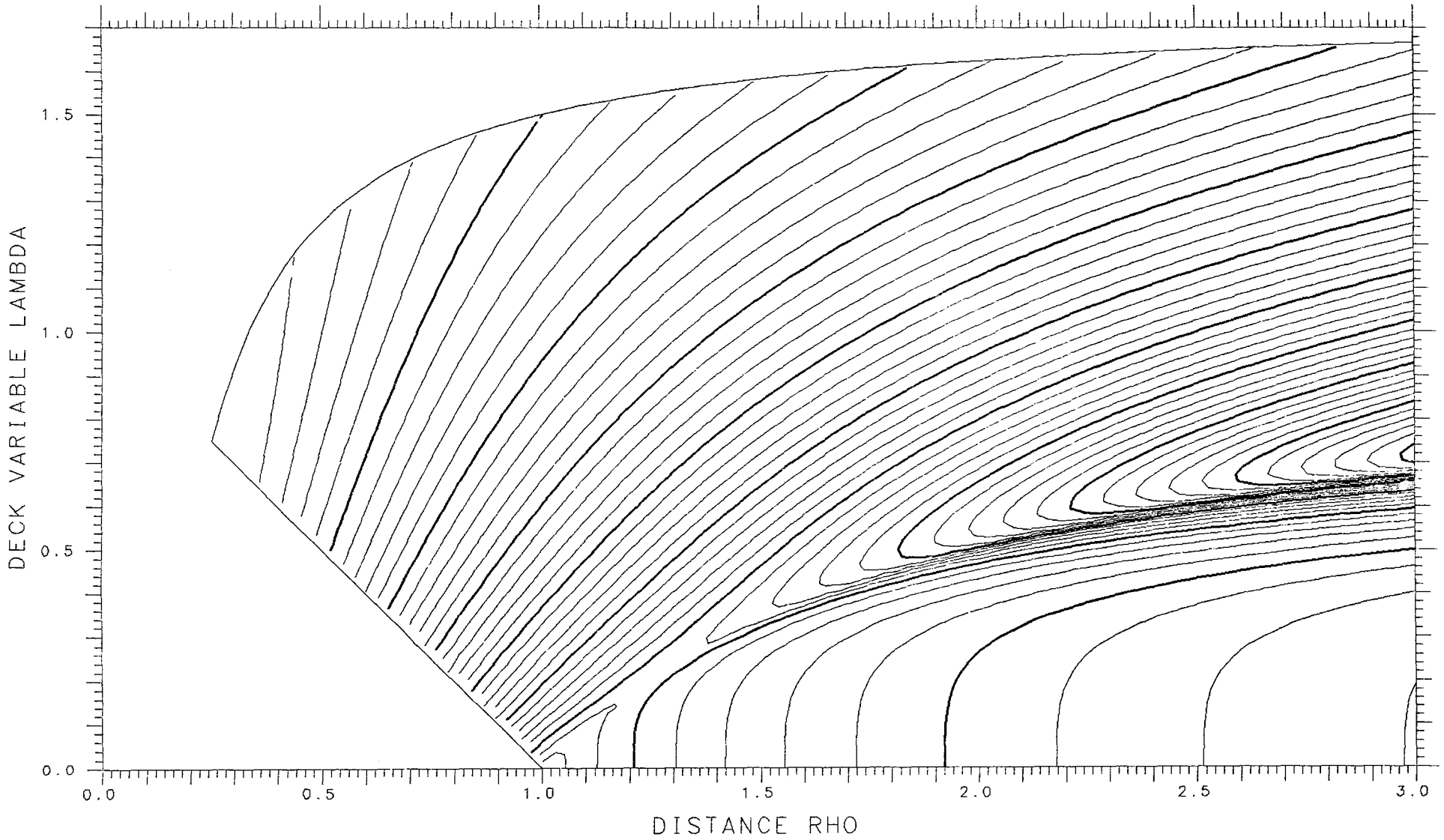

X=1.050 ASYMMETRY DELTA= .300 FRACTIONAL= .8650

SPHERES -.20536 TANGENT .07354 LENGTH 12.513 ENERGY 773.18 SPACING .005

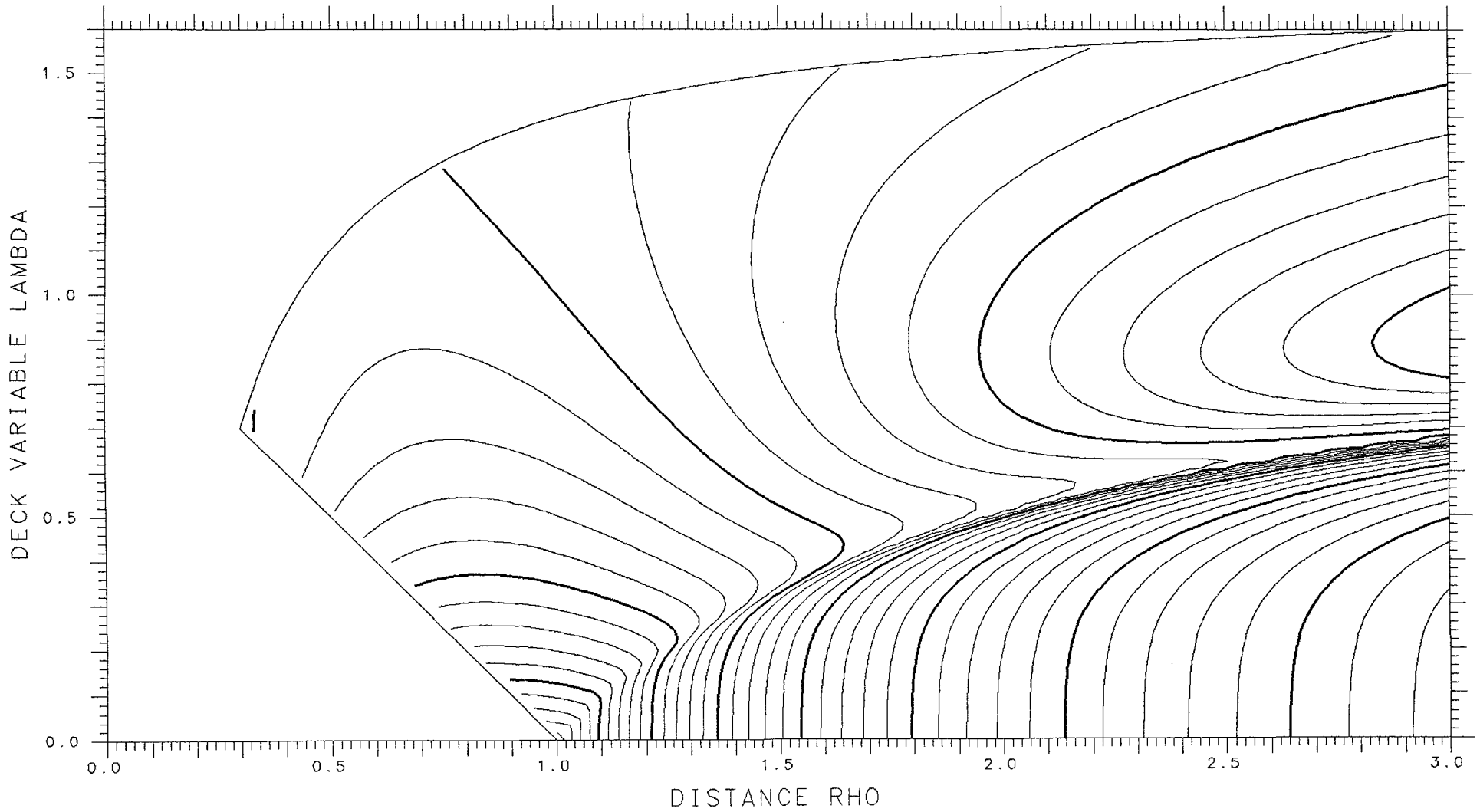

X= .250 ASYMMETRY DELTA= .275 FRACTIONAL= .8447

SPHERES .08235 TANGENT .15607 LENGTH 7.148 ENERGY 273.58 SPACING .005

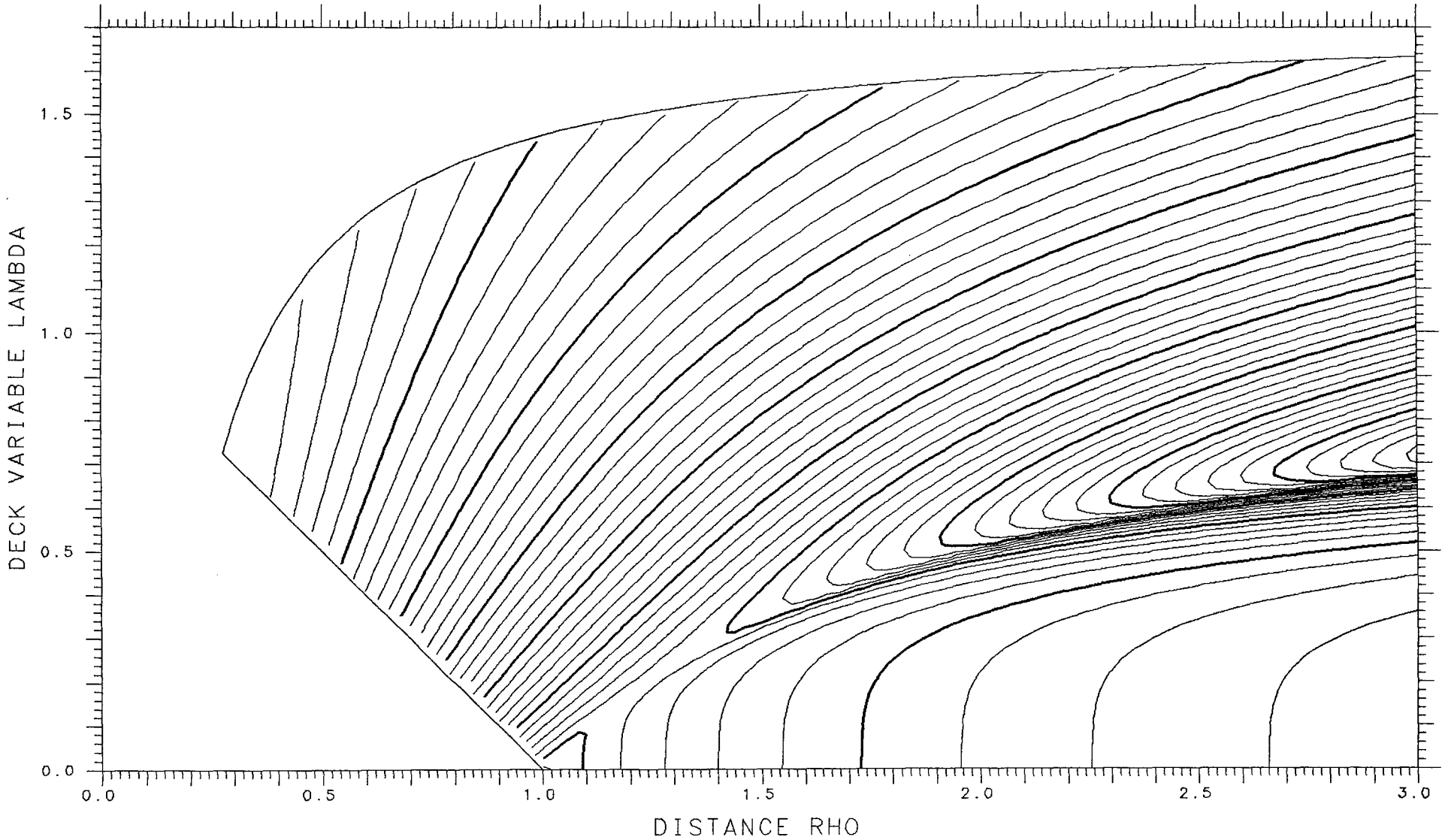

X=1.050 ASYMMETRY DELTA= .275 FRACTIONAL= .8447

SPHERES -.23817 TANGENT .07147 LENGTH 12.658 ENERGY 773.18 SPACING .005

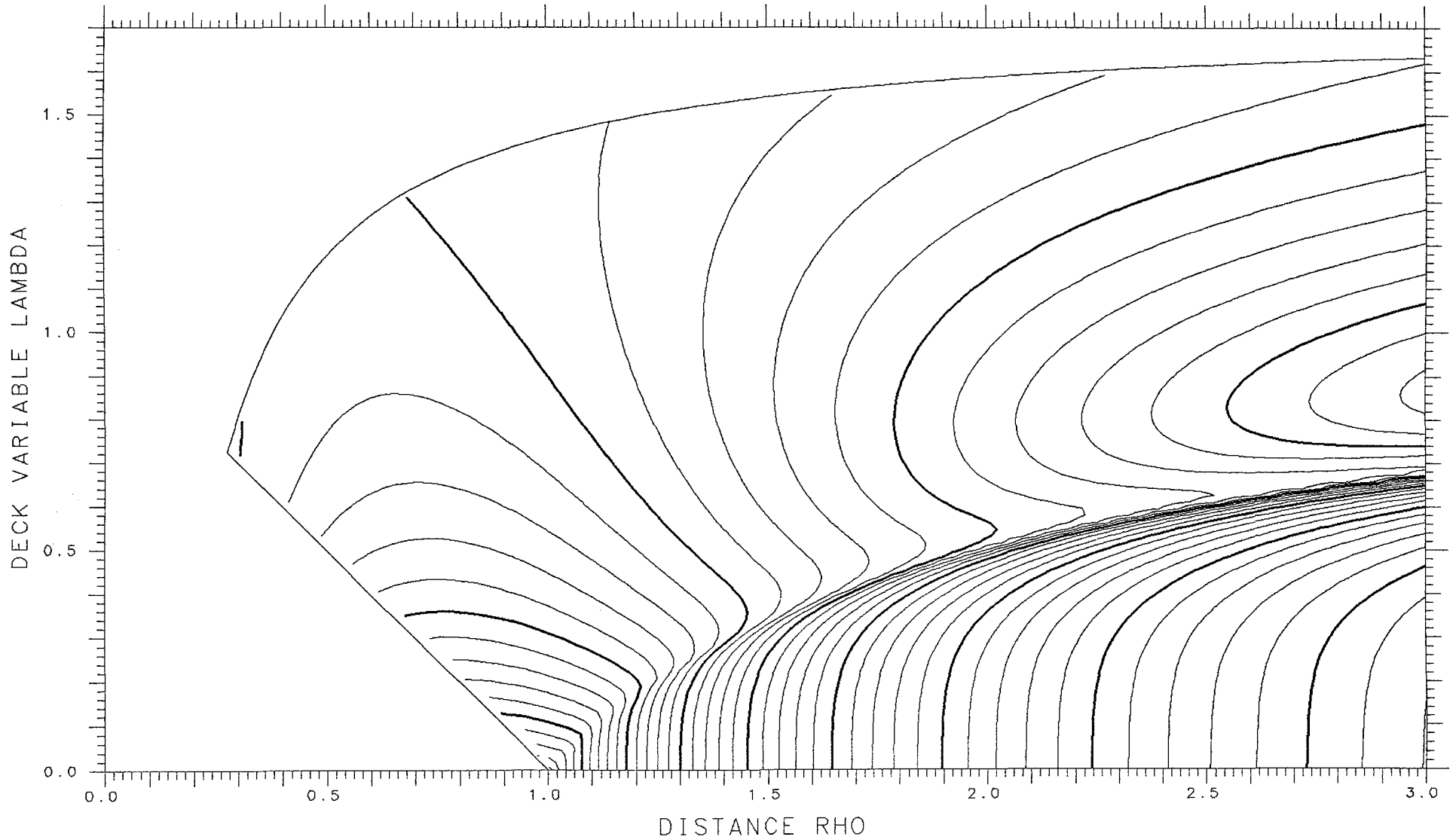

X= .250 ASYMMETRY DELTA= .300 FRACTIONAL= .8650

SPHERES .08141 TANGENT .14782 LENGTH 7.066 ENERGY 273.58 SPACING .005

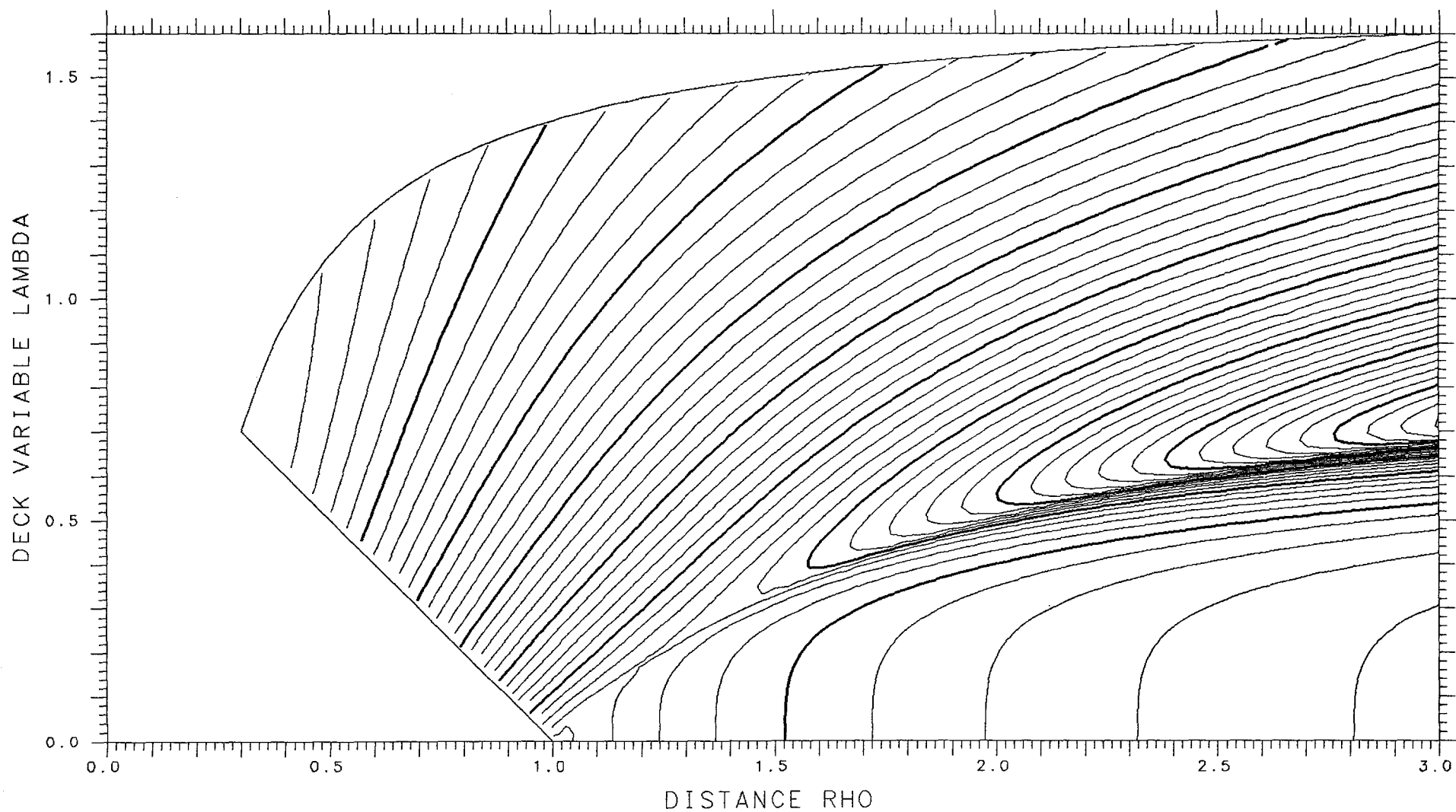

X=1.050 ASYMMETRY DELTA= .250 FRACTIONAL= .8224

SPHERES -.27249 TANGENT .06858 LENGTH 12.796 ENERGY 773.18 SPACING .005

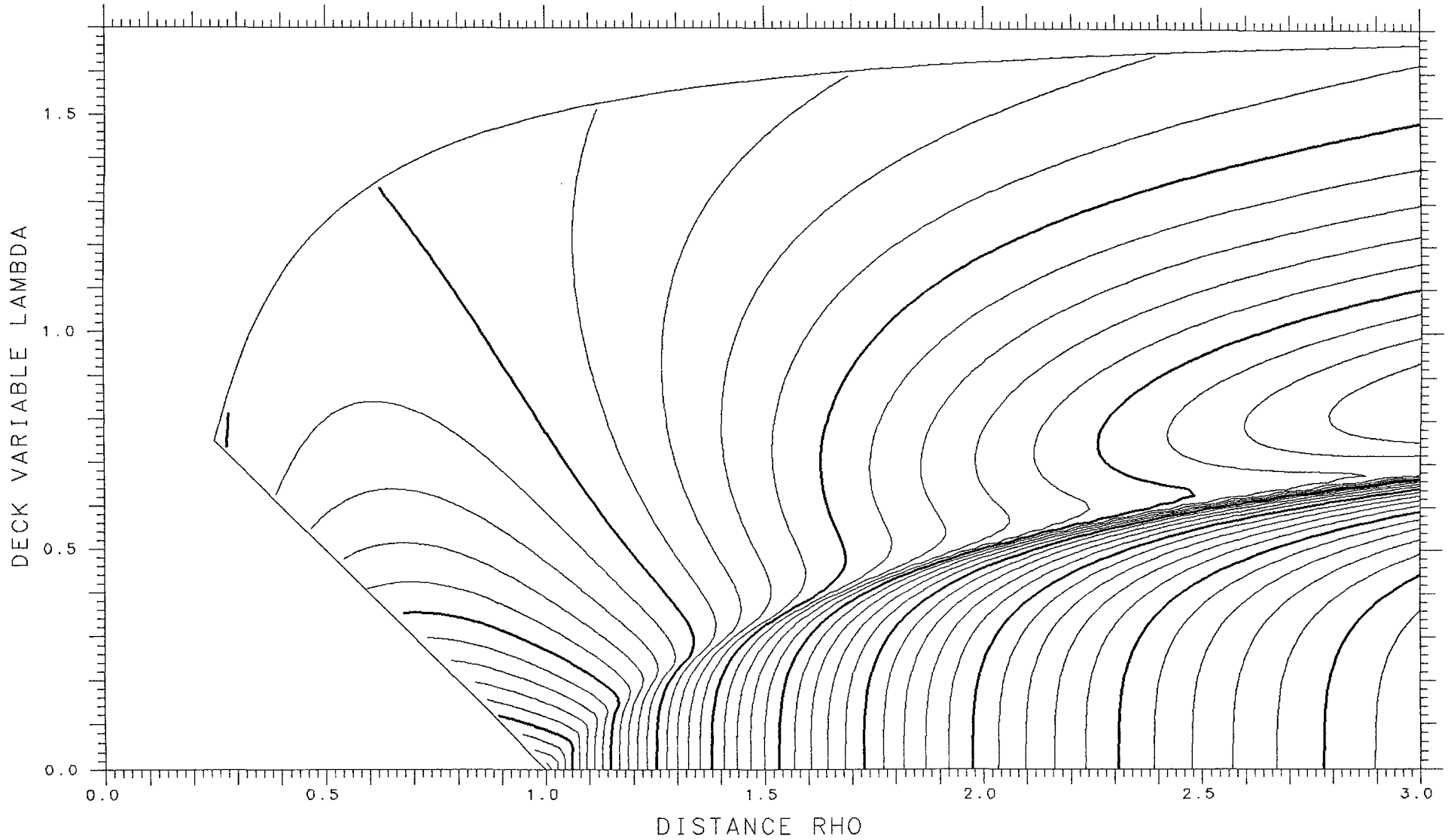

X= .250 ASYMMETRY DELTA= .325 FRACTIONAL= .8832

SPHERES .07994 TANGENT .13928 LENGTH 6.982 ENERGY 273.58 SPACING .005

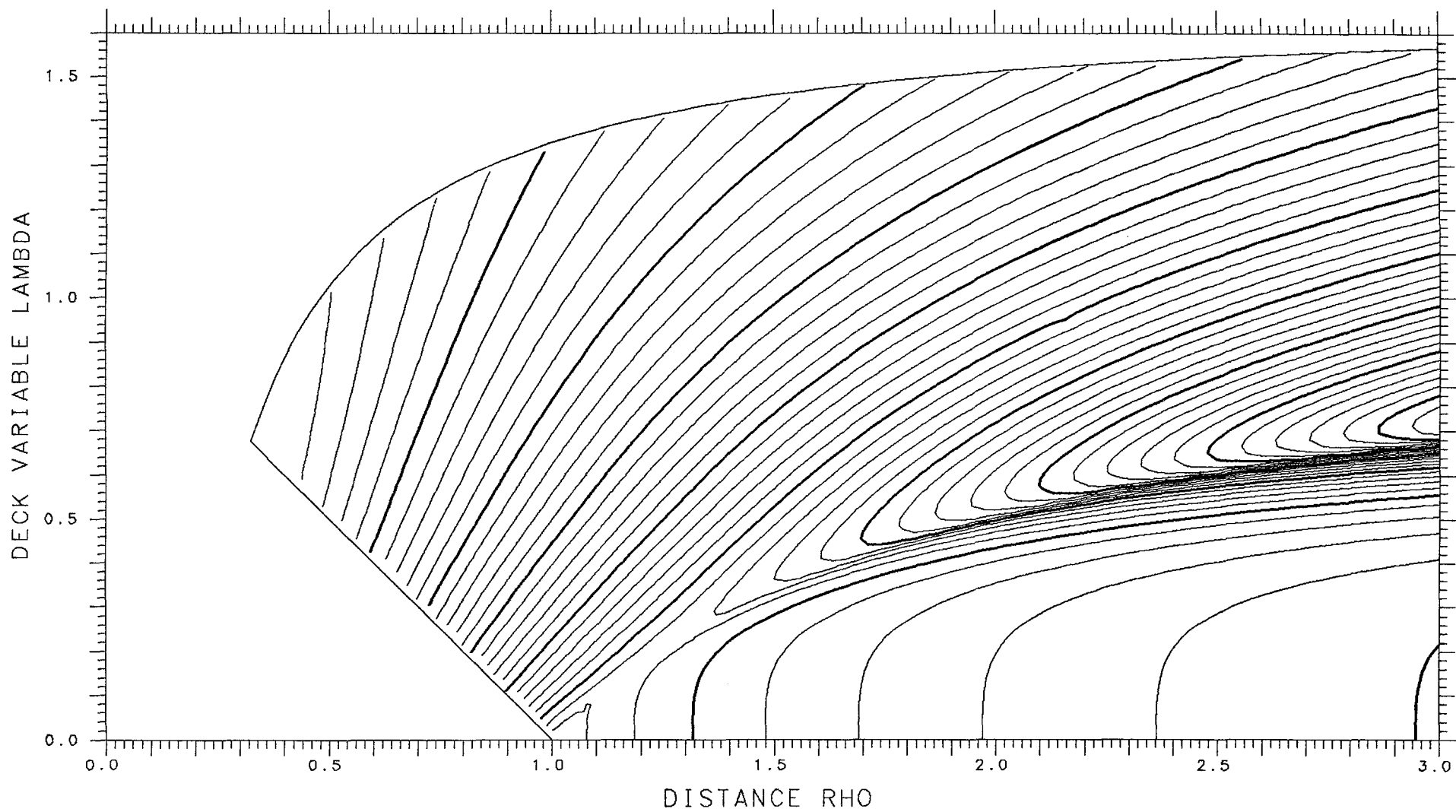

X=1.050 ASYMMETRY DELTA= .225 FRACTIONAL= .7979

SPHERES -.30768 TANGENT .06497 LENGTH 12.927 ENERGY 773.18 SPACING .005

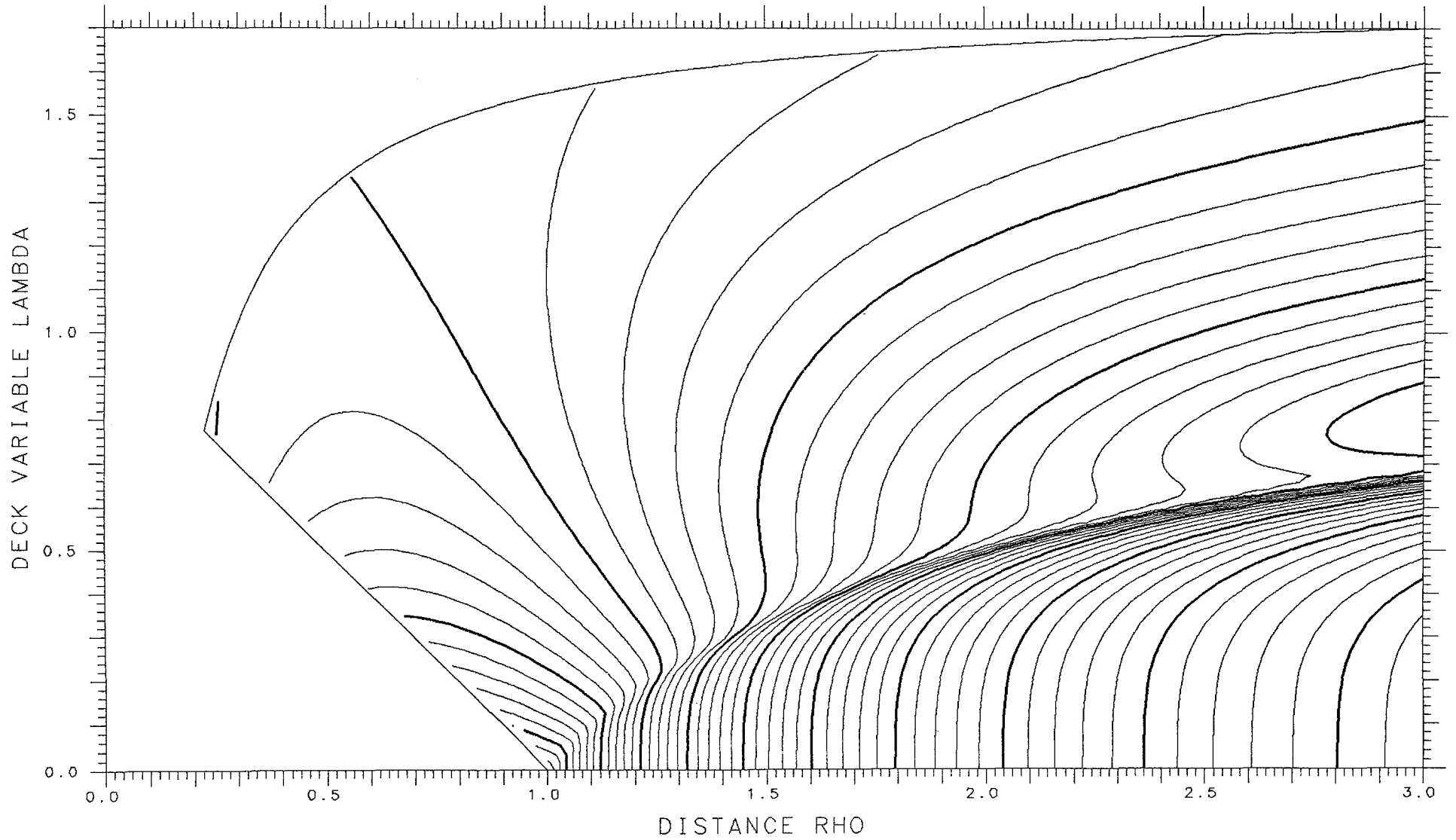

X= .250

ASYMMETRY DELTA= .350 FRACTIONAL= .8996

SPHERES .07792

TANGENT .13056

LENGTH 6.894

ENERGY 273.58

SPACING .005

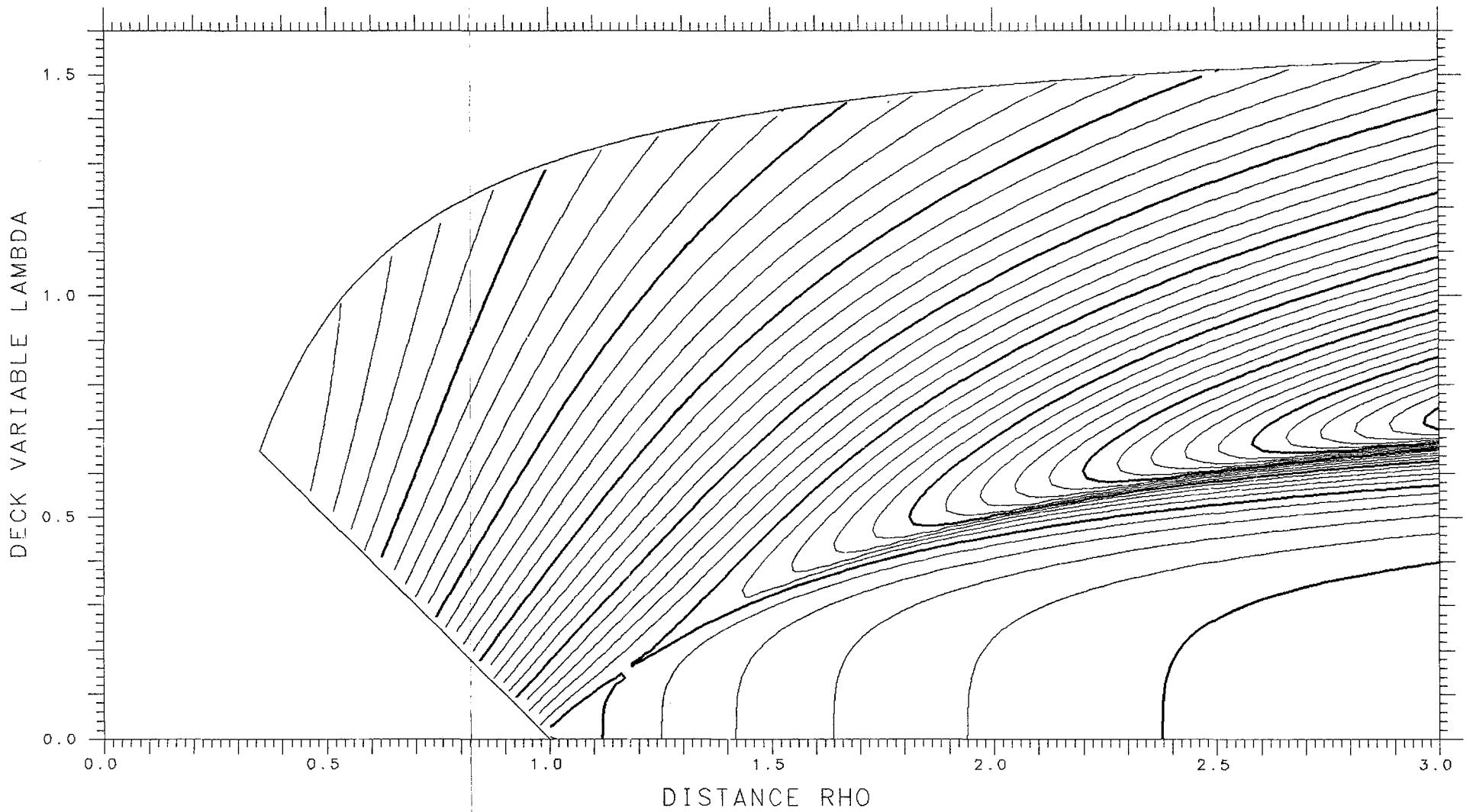

X=1.050 ASYMMETRY DELTA= .200 FRACTIONAL= .7714

SPHERES -.34296 TANGENT .06078 LENGTH 13.048 ENERGY 773.18 SPACING .005

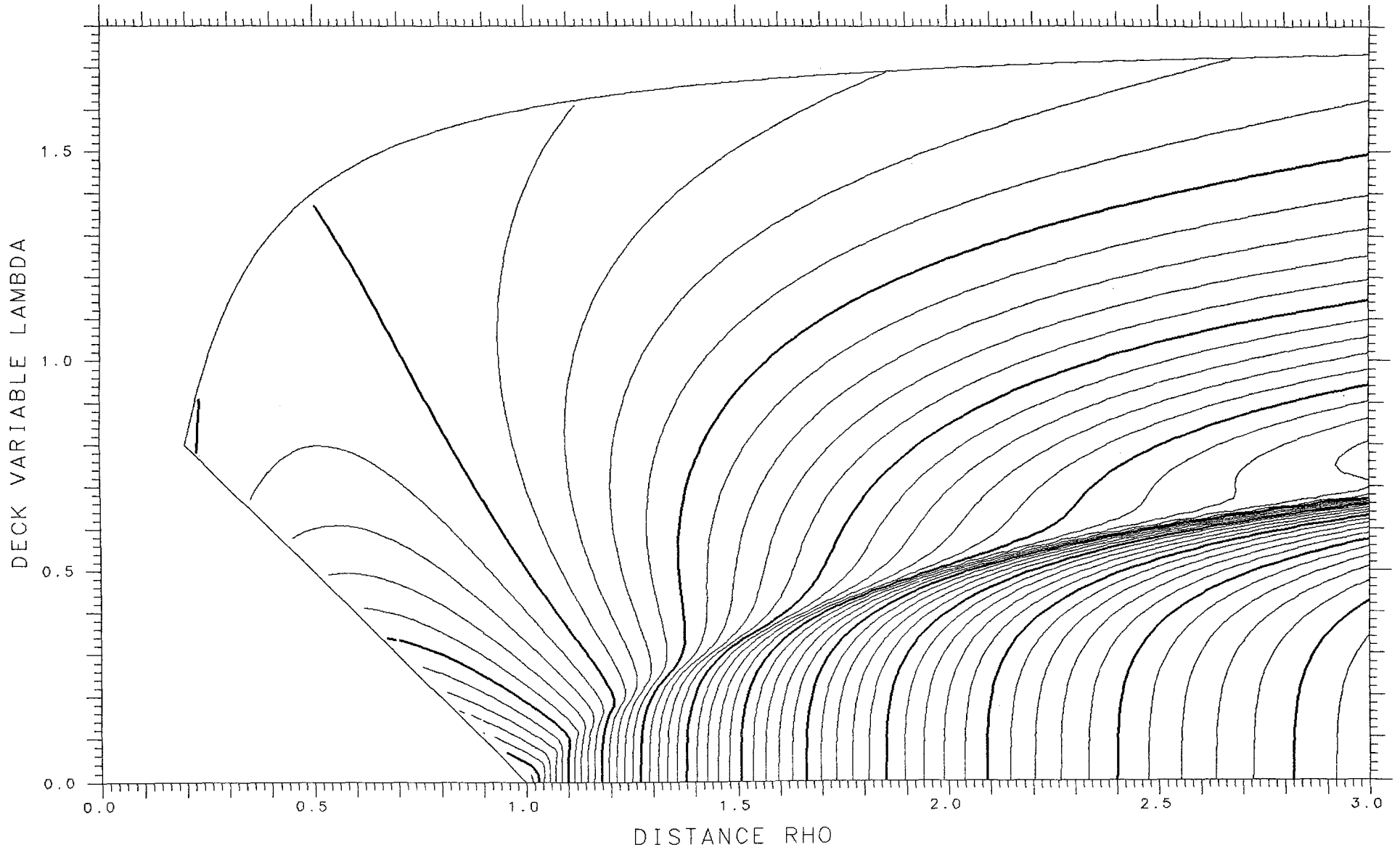

X= .250 ASYMMETRY DELTA= .375 FRACTIONAL= .9141

SPHERES .07540 TANGENT .12173 LENGTH 6.805 ENERGY 273.58 SPACING .005

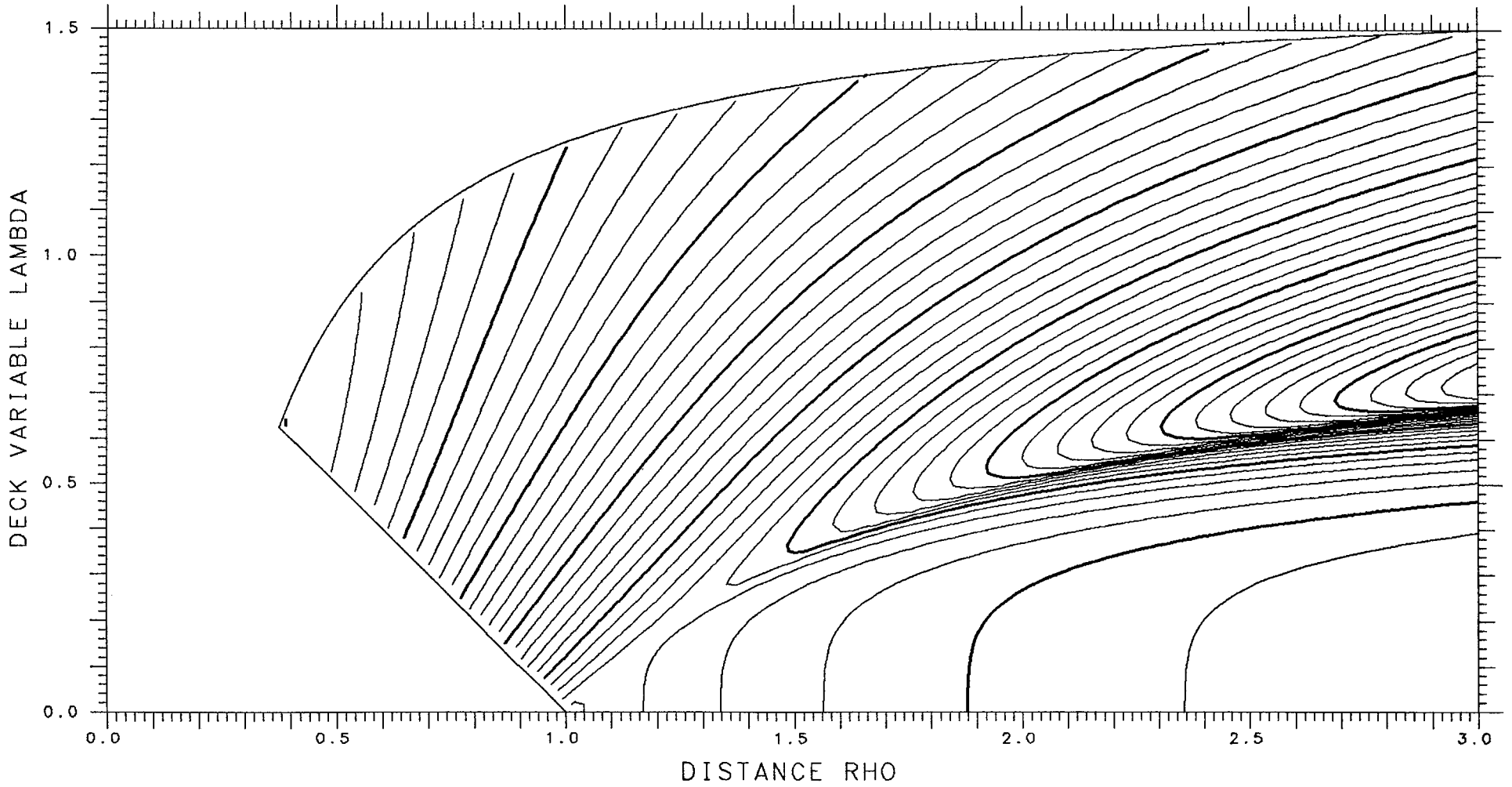

X=1.050

ASYMMETRY DELTA= .175

FRACTIONAL= .7429

SPHERES -.37746

TANGENT .05623

LENGTH 13.159

ENERGY 773.18

SPACING .005

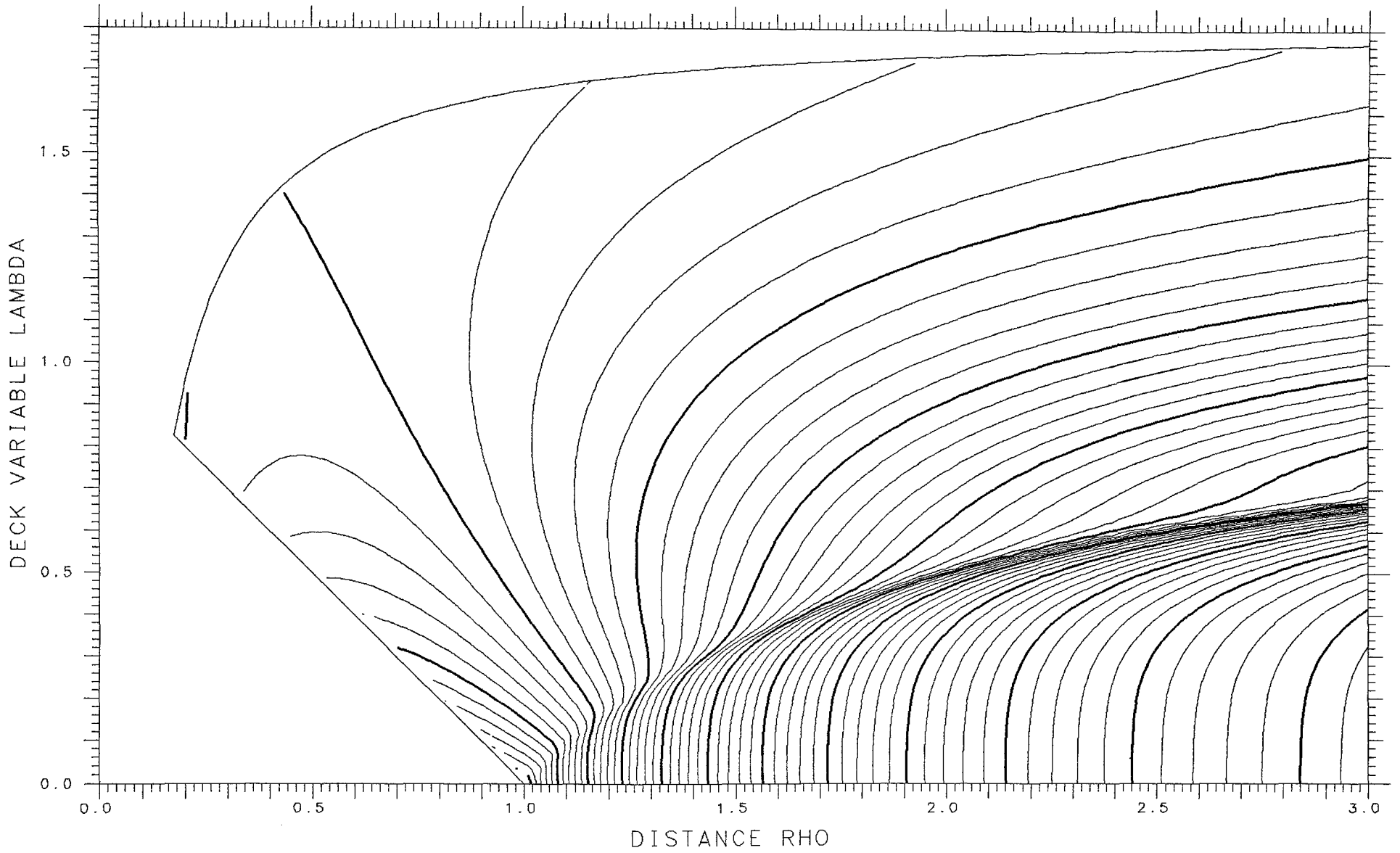

X= .250 ASYMMETRY DELTA= .400 FRACTIONAL= .9270

SPHERES .07242 TANGENT .11289 LENGTH 6.715 ENERGY 273.58 SPACING .005

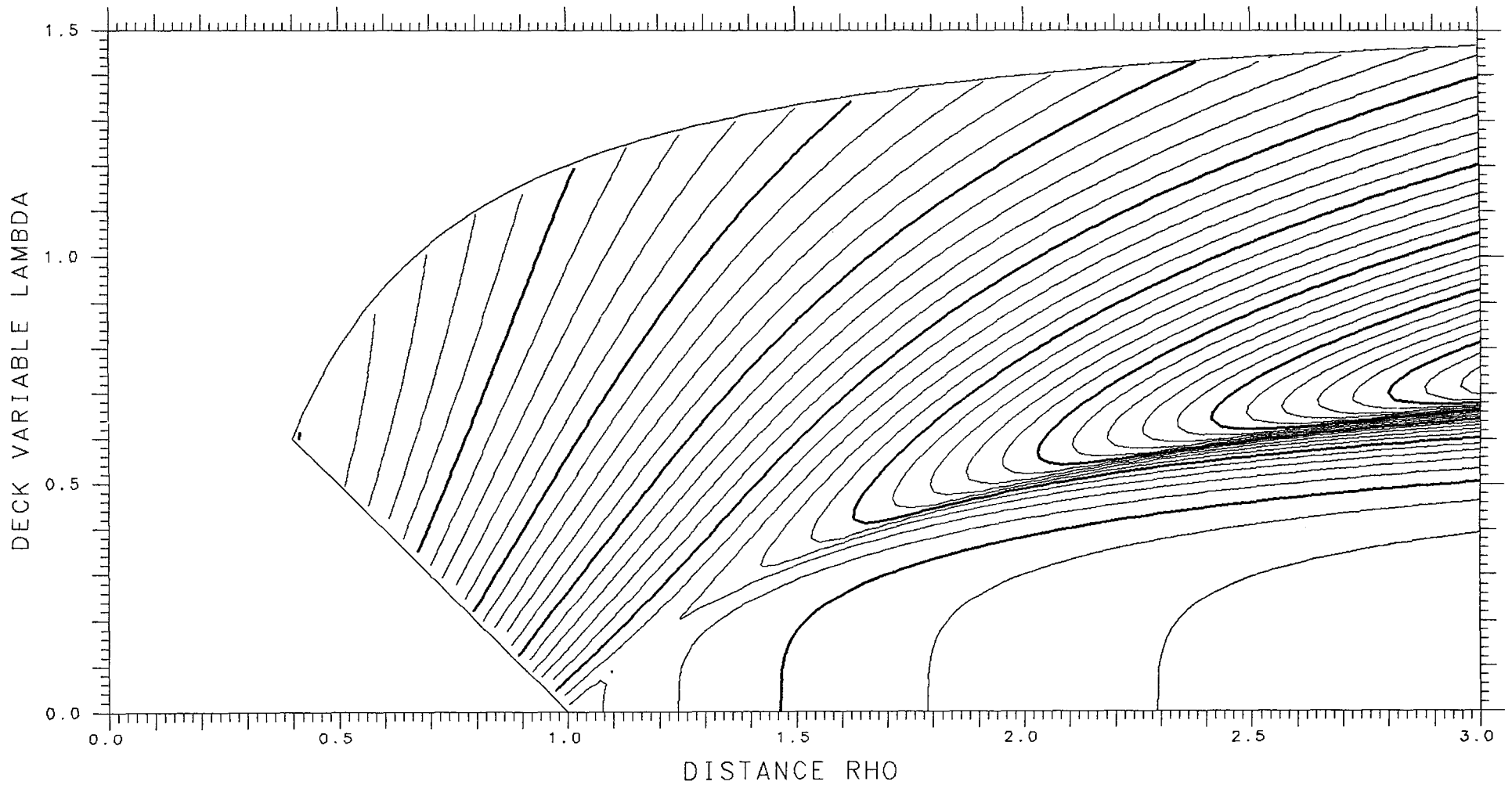

X=1.050 ASYMMETRY DELTA= .150 FRACTIONAL= .7124

SPHERES -.41021 TANGENT .05152 LENGTH 13.259 ENERGY 773.18 SPACING .005

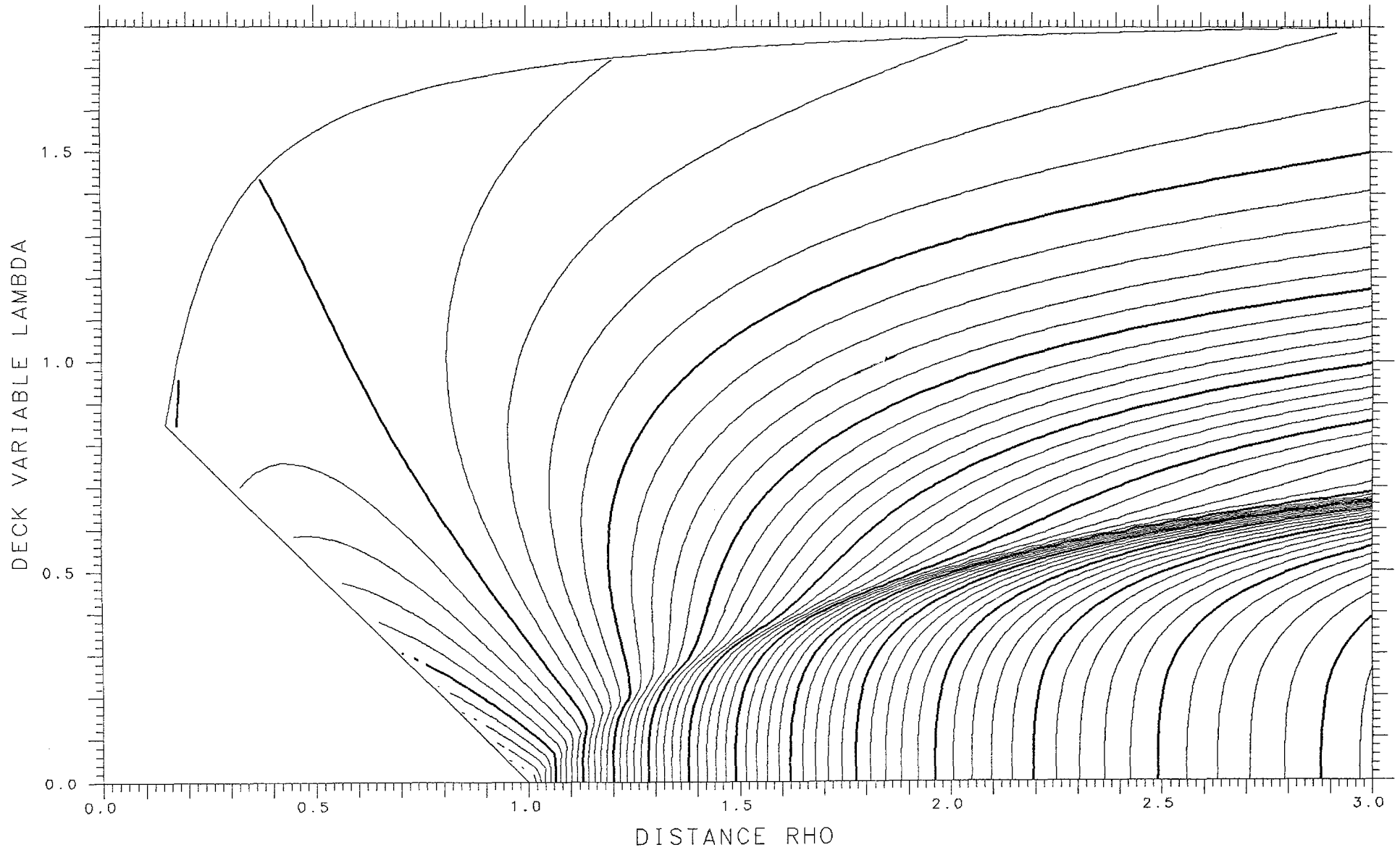

X= .250 ASYMMETRY DELTA= .425 FRACTIONAL= .9384

SPHERES .06902 TANGENT .10411 LENGTH 6.624 ENERGY 273.58 SPACING .005

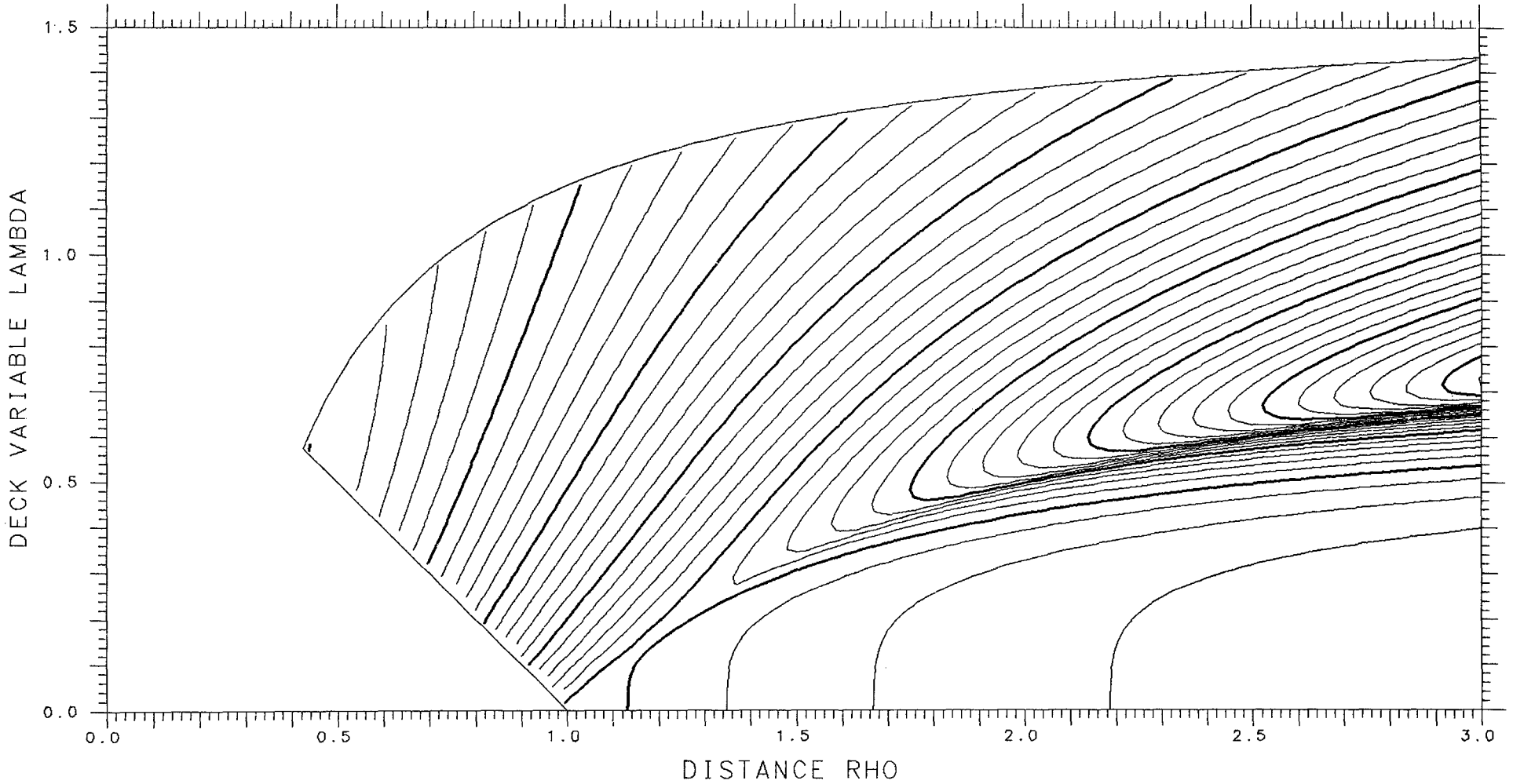

X=1.050

ASYMMETRY DELTA= .125

FRACTIONAL= .6800

SPHERES -.44020

TANGENT .04693

LENGTH 13.345

ENERGY 773.18

SPACING .005

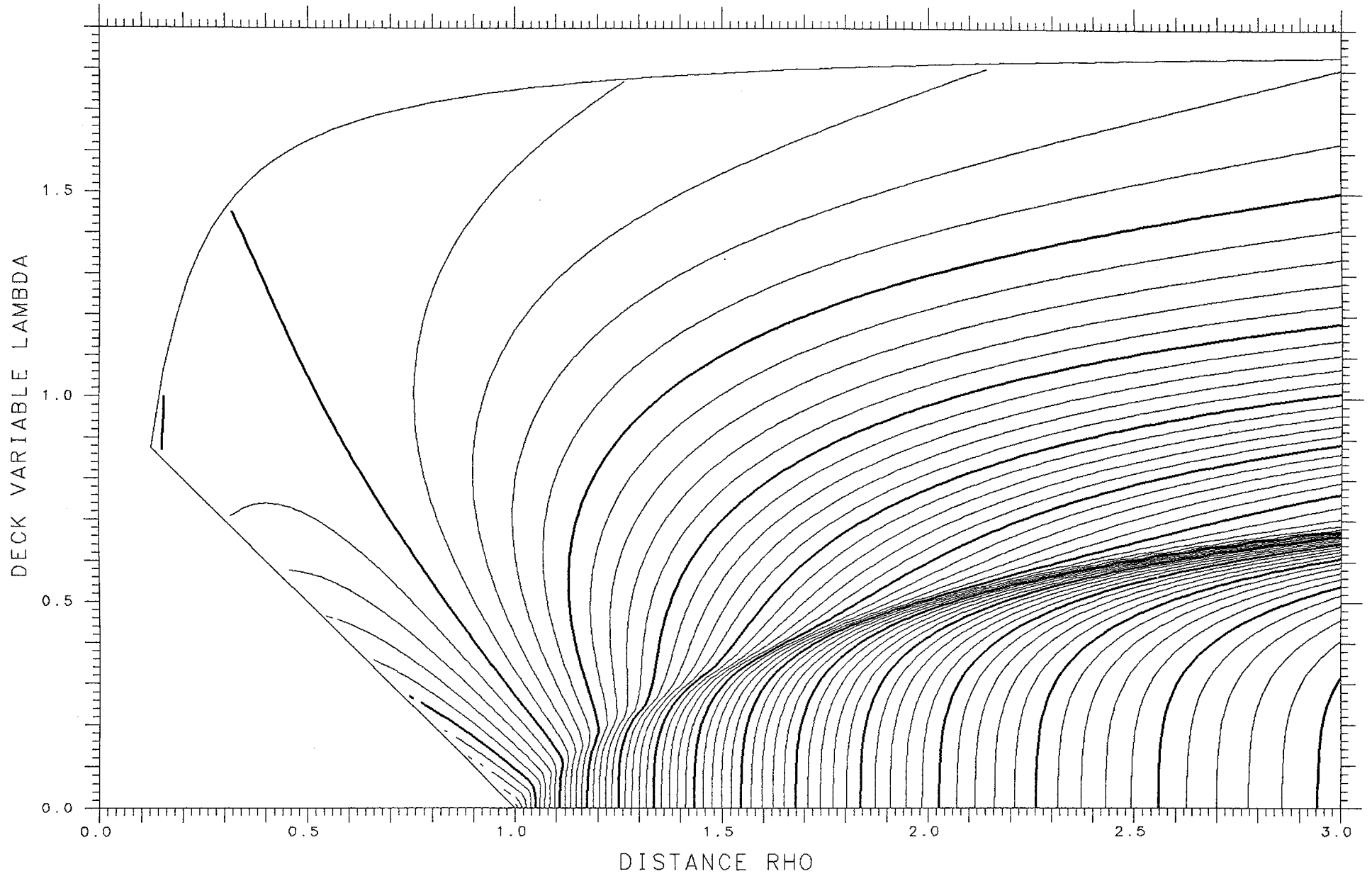

X= .300 ASYMMETRY DELTA=0. FRACTIONAL= .5000

SPHERES .03790 TANGENT .19539 LENGTH 8.213 ENERGY 313.27 SPACING .005 SADDLE .16890

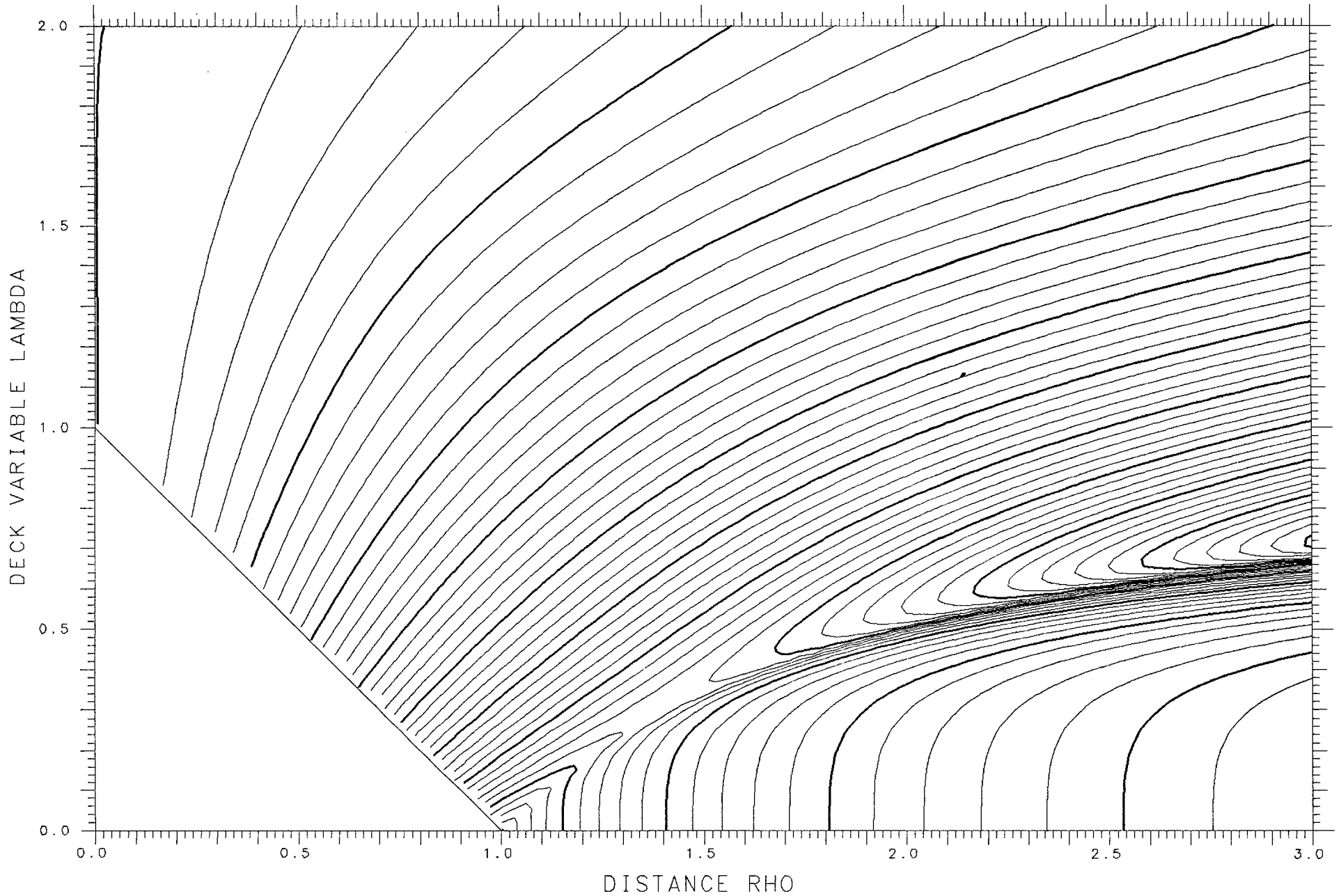

X=1.050 ASYMMETRY DELTA= .100 FRACTIONAL= .6461

SPHERES -.46643 TANGENT .04271 LENGTH 13.418 ENERGY 773.18 SPACING .005

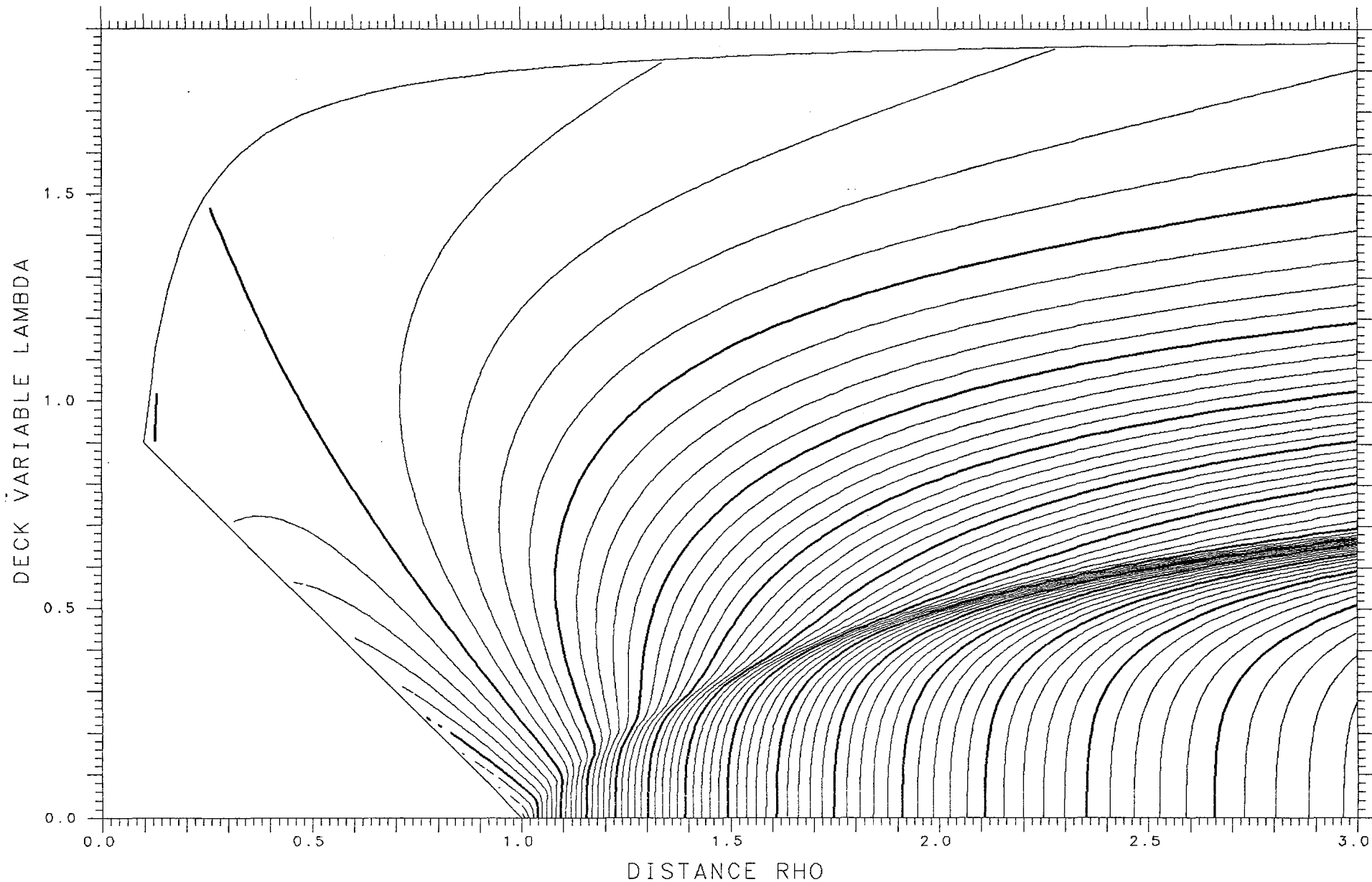

X= .300 ASYMMETRY DELTA= .025 FRACTIONAL= .5374

SPHERES .03829 TANGENT .19499 LENGTH 8.208 ENERGY 313.27 SPACING .005 SADDLE .16869

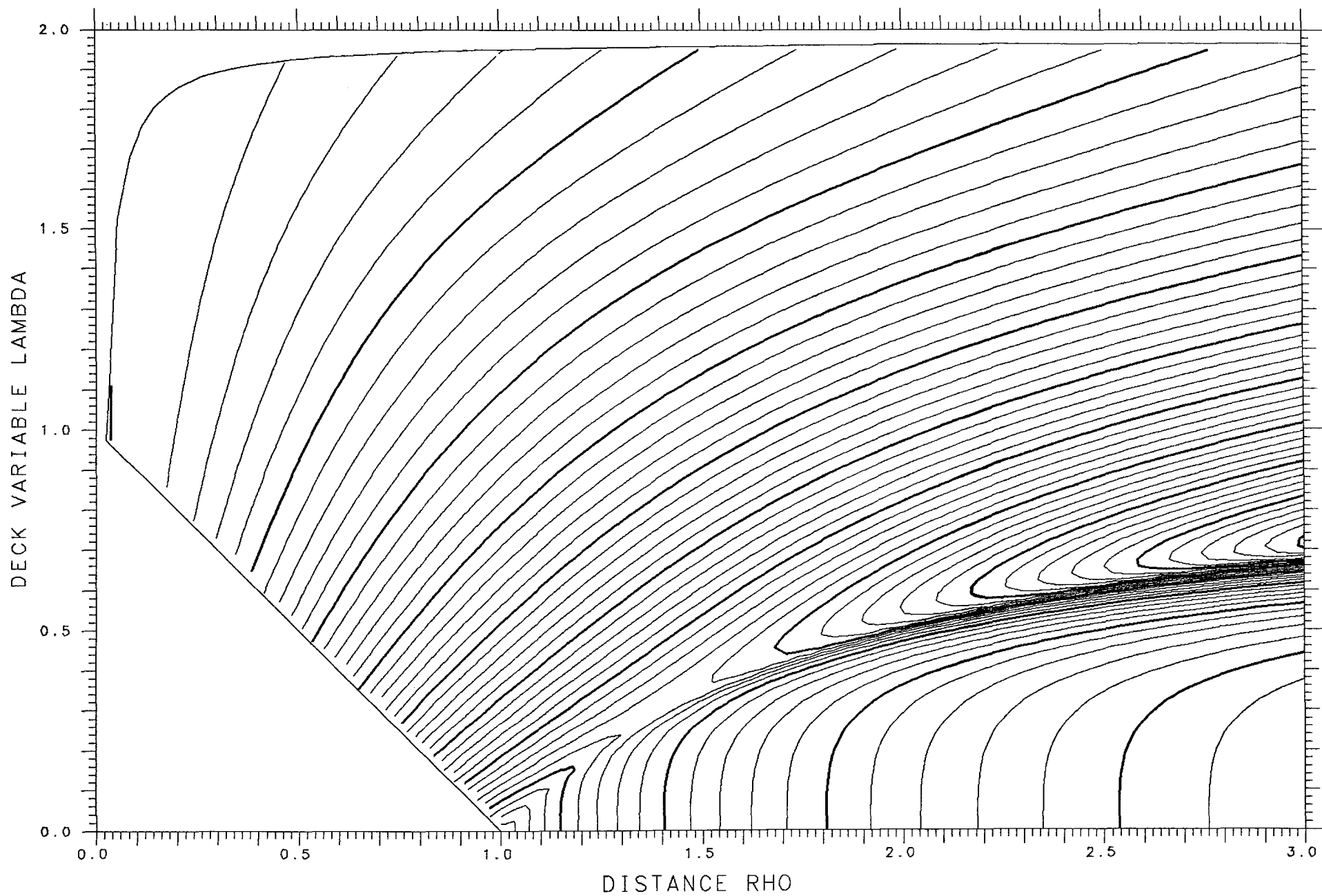

X=1.050 ASYMMETRY DELTA= .075 FRACTIONAL= .6108

SPHERES -.48795 TANGENT .03911 LENGTH 13.475 ENERGY 773.18 SPACING .005

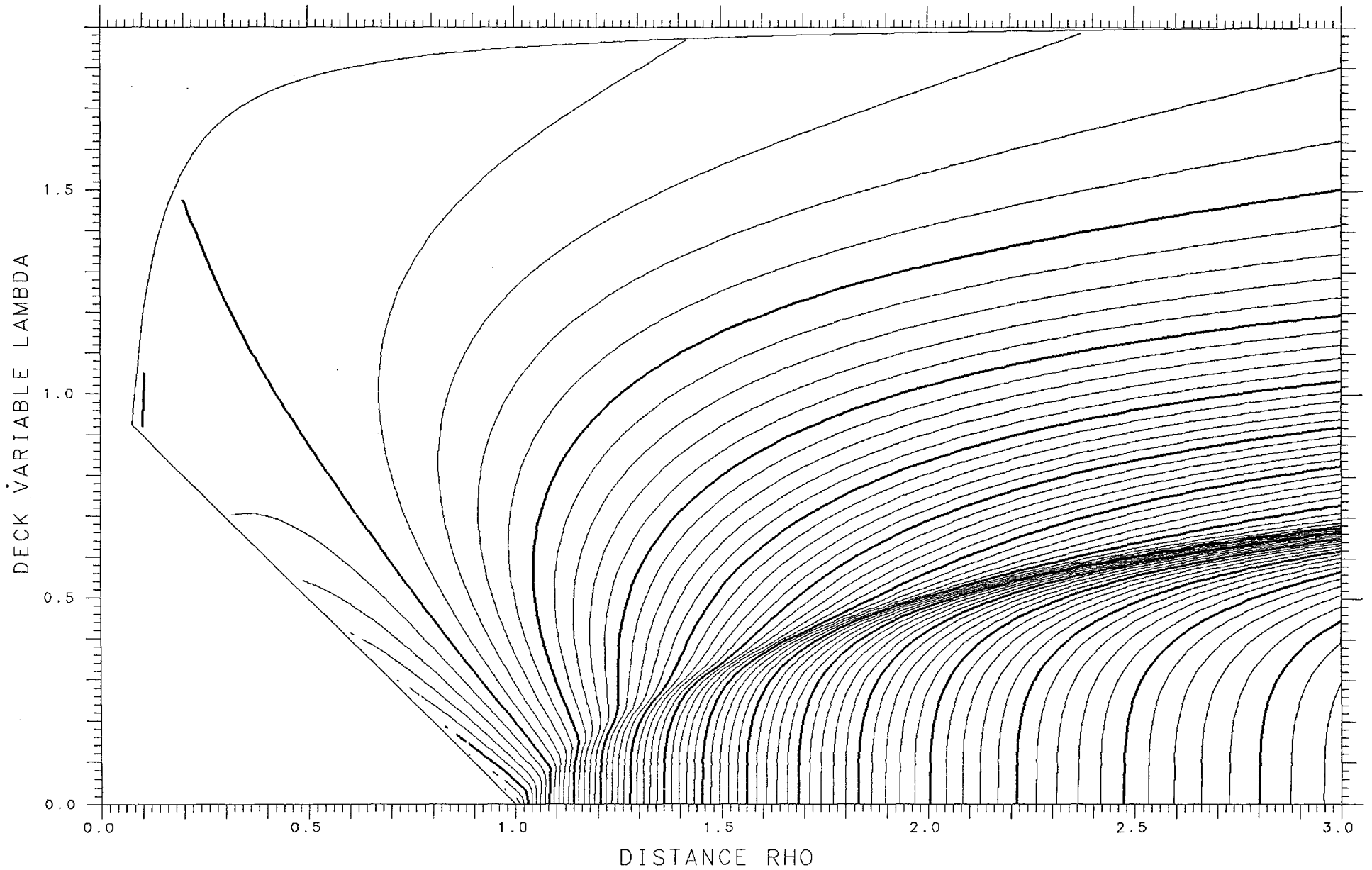

X= .300 ASYMMETRY DELTA= .050 FRACTIONAL= .5745

SPHERES .03944 TANGENT .19381 LENGTH 8.193 ENERGY 313.27 SPACING .005 SADDLE .16806

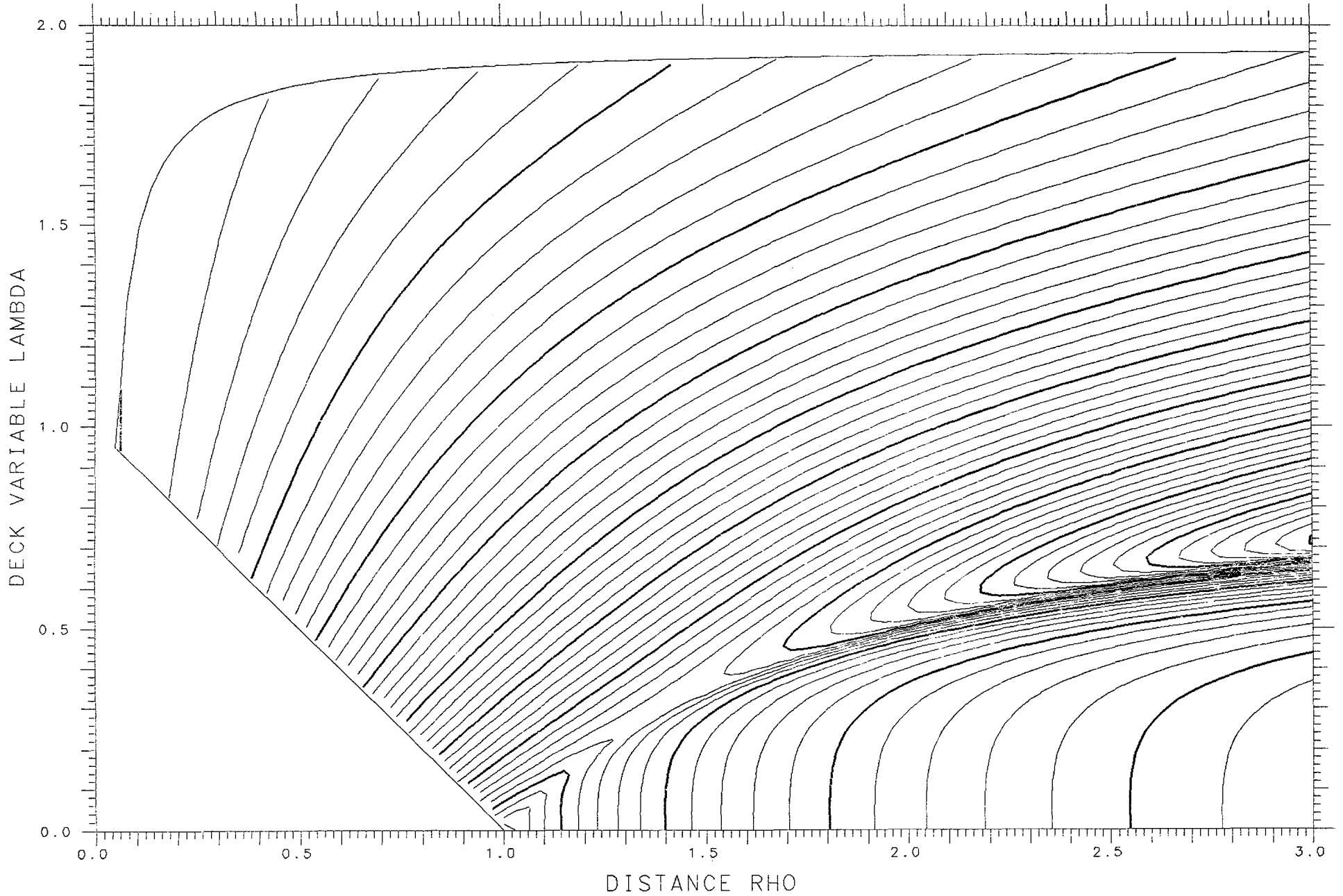

X=1.050 ASYMMETRY DELTA= .050 FRACTIONAL= .5745

SPHERES -.50396 TANGENT .03636 LENGTH 13.517 ENERGY 773.18 SPACING .005

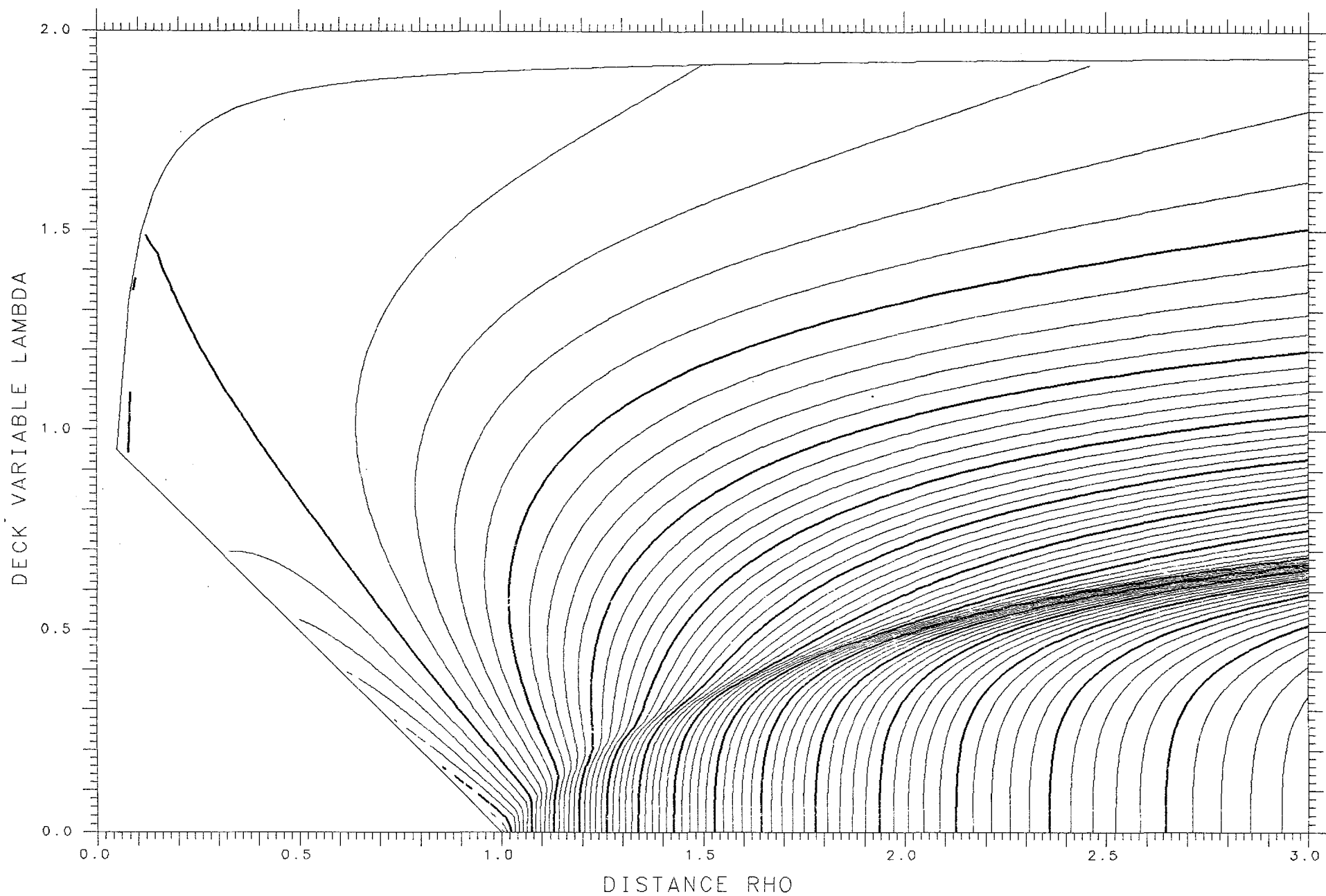

X= .300 ASYMMETRY DELTA= .075 FRACTIONAL= .6108

SPHERES .04127 TANGENT .19185 LENGTH 8.167 ENERGY 313.27 SPACING .005 SADDLE .16698

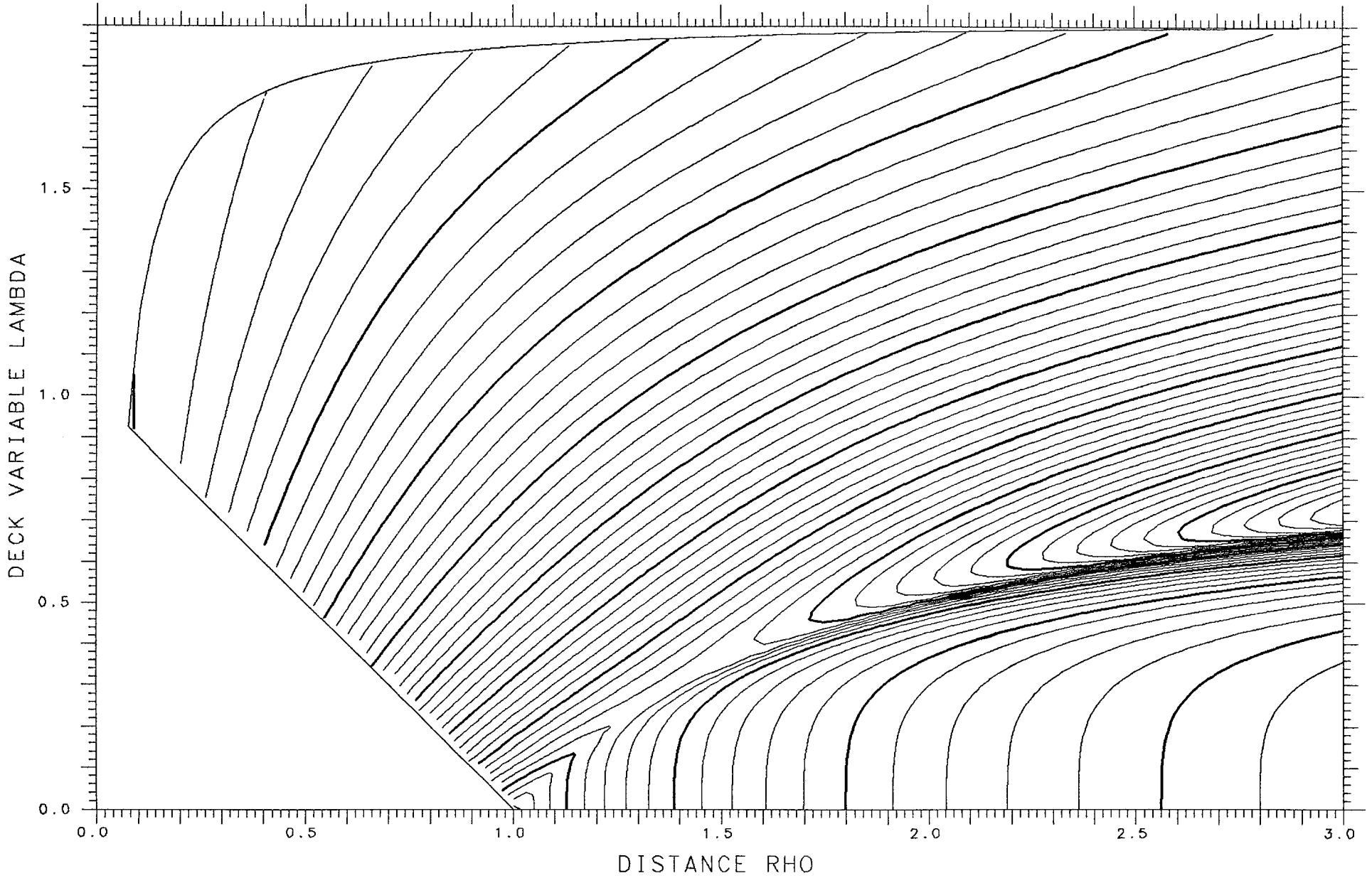

X=1.050 ASYMMETRY DELTA= .025 FRACTIONAL= .5374

SPHERES -.51383 TANGENT .03464 LENGTH 13.542 ENERGY 773.18 SPACING .005

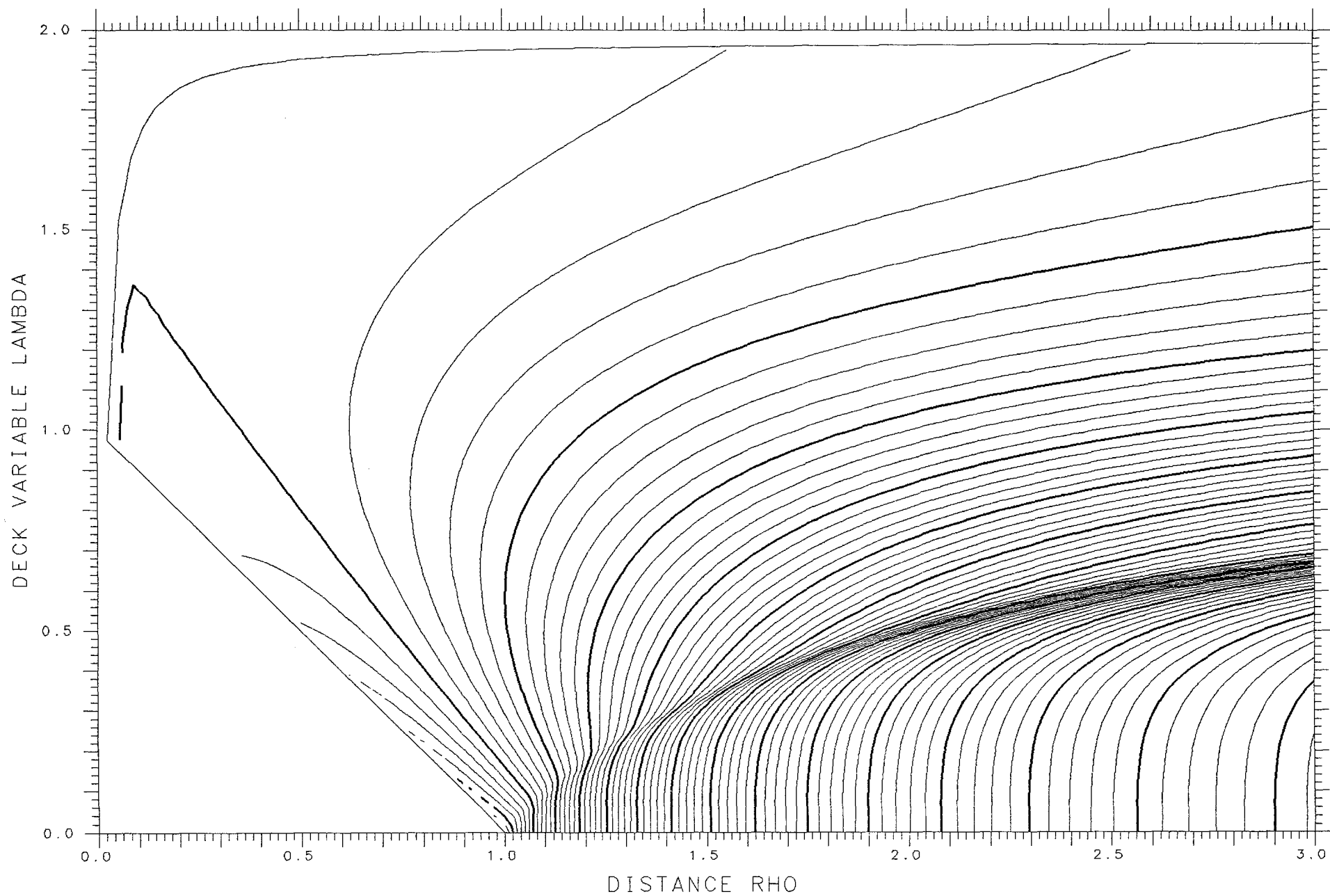

X= .300 ASYMMETRY DELTA= .100 FRACTIONAL= .6461

SPHERES .04366 TANGENT .18912 LENGTH 8.133 ENERGY 313.27 SPACING .005 SADDLE .16544

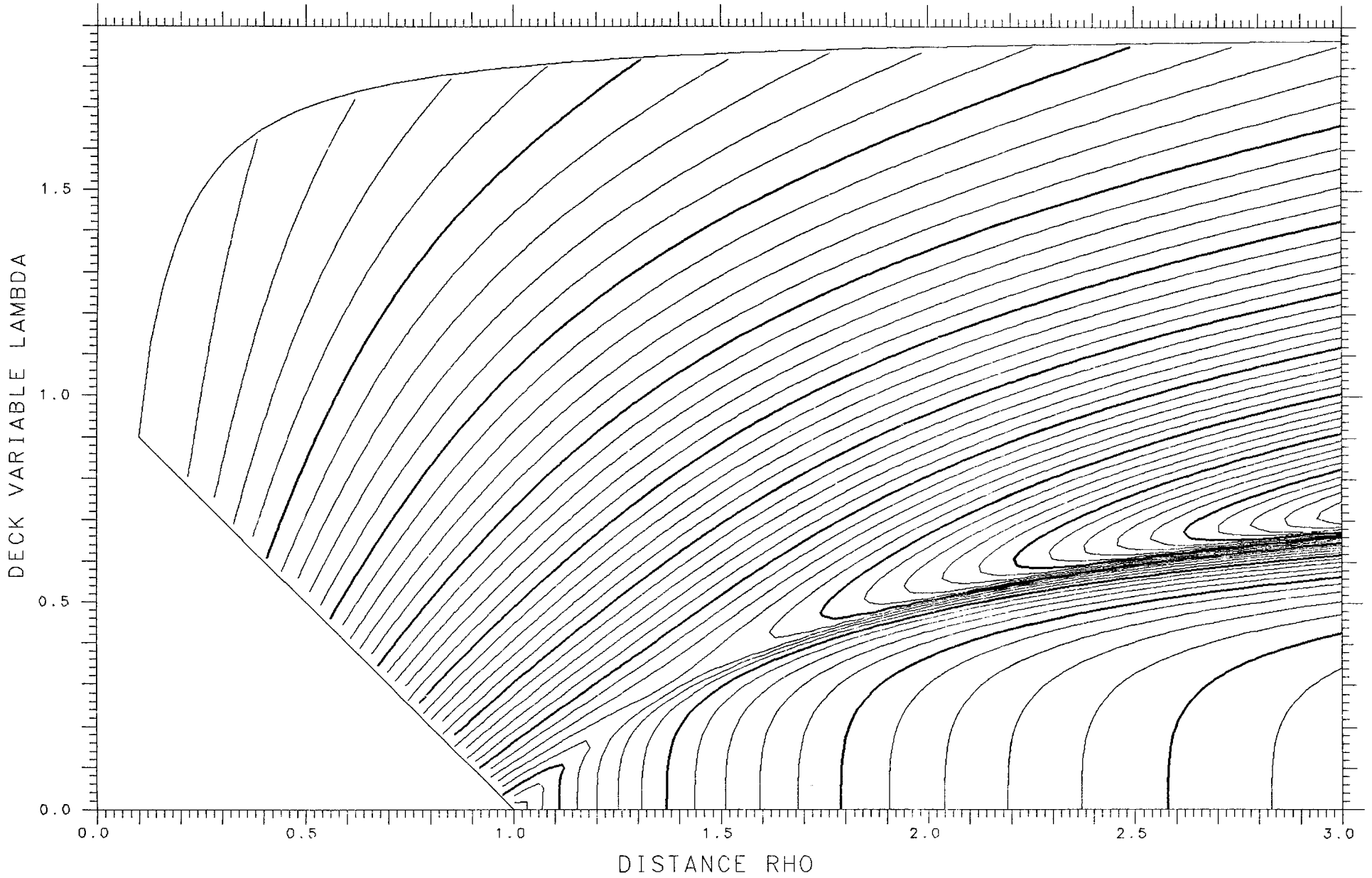

X=1.050

ASYMMETRY DELTA=0.

FRACTIONAL= .5000

SPHERES -.51716

TANGENT .03405

LENGTH 13.551

ENERGY 773.18

SPACING .005

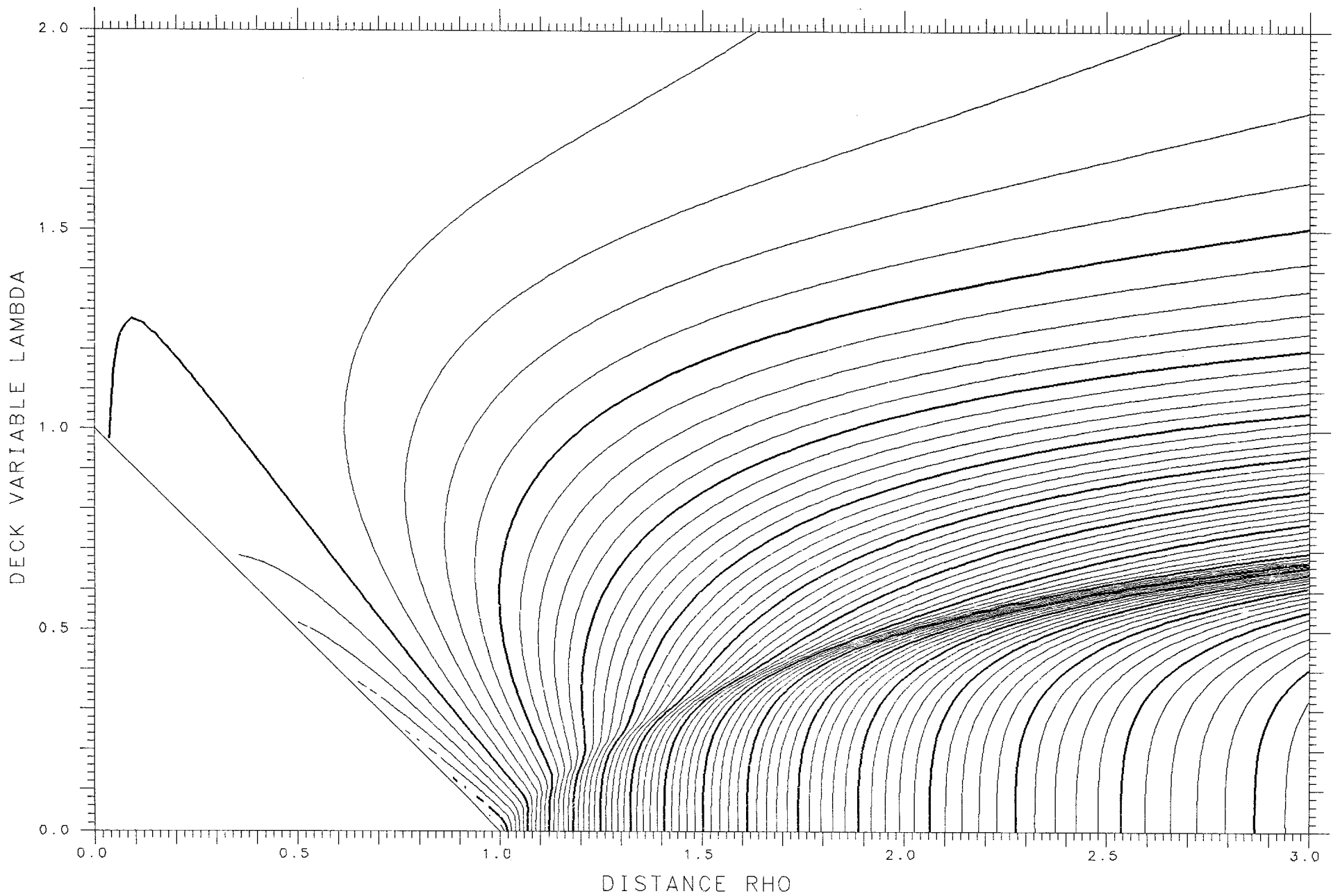

X= .300 ASYMMETRY DELTA= .125 FRACTIONAL= .6800

SPHERES .04646 TANGENT .18564 LENGTH 8.089 ENERGY 313.27 SPACING .005 SADDLE .16340

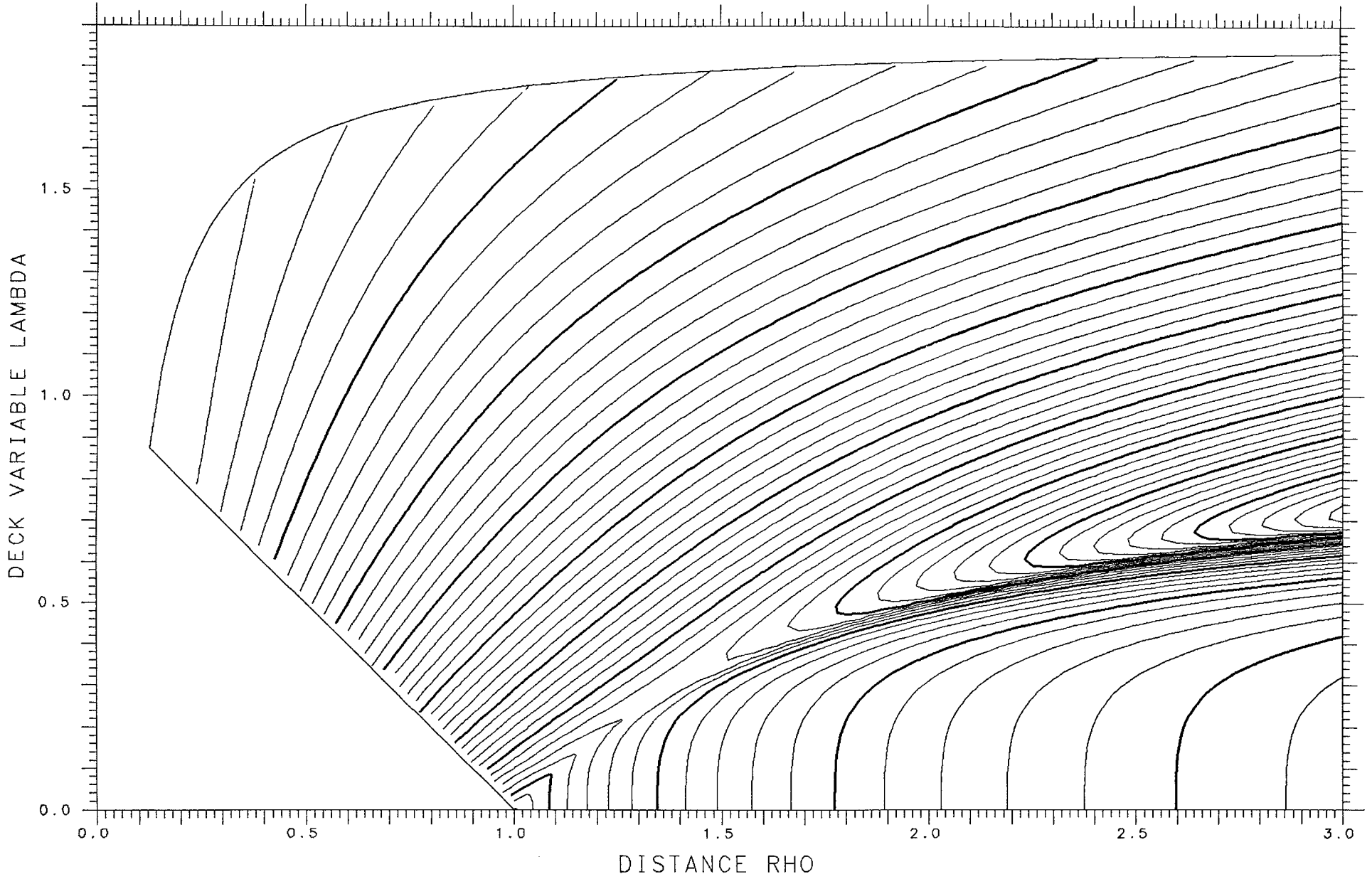

X=1.000 ASYMMETRY DELTA= .425 FRACTIONAL= .9384

SPHERES -.06748 TANGENT .07286 LENGTH 11.505 ENERGY 747.97 SPACING .002

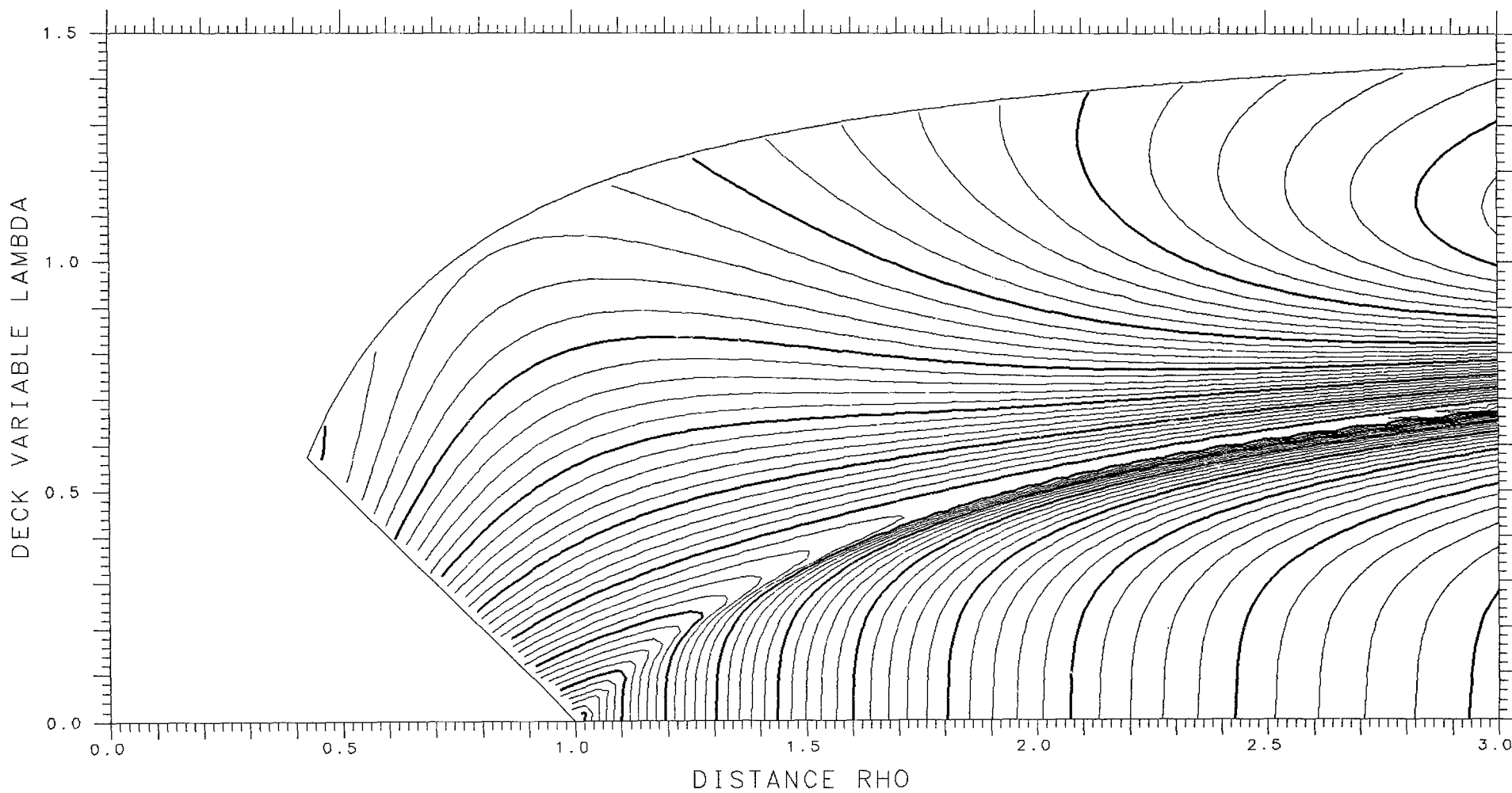

X= .300 ASYMMETRY DELTA= .150 FRACTIONAL= .7124

SPHERES .04949 TANGENT .18142 LENGTH 8.036 ENERGY 313.27 SPACING .005 SADDLE .16082

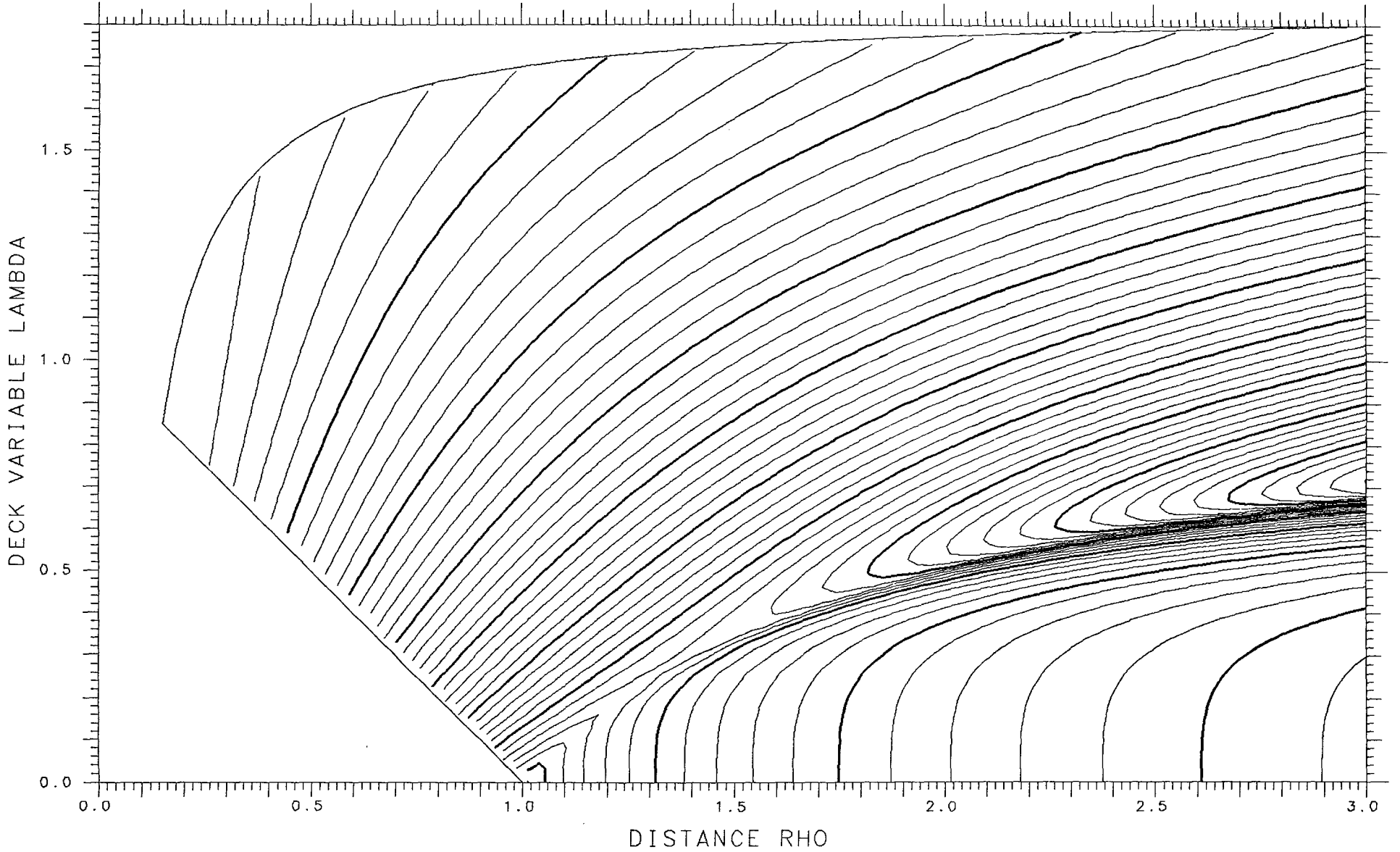

X=1.000 ASYMMETRY DELTA= .400 FRACTIONAL= .9270
SPHERES -.08643 TANGENT .07546 LENGTH 11.664 ENERGY 747.97 SPACING .002

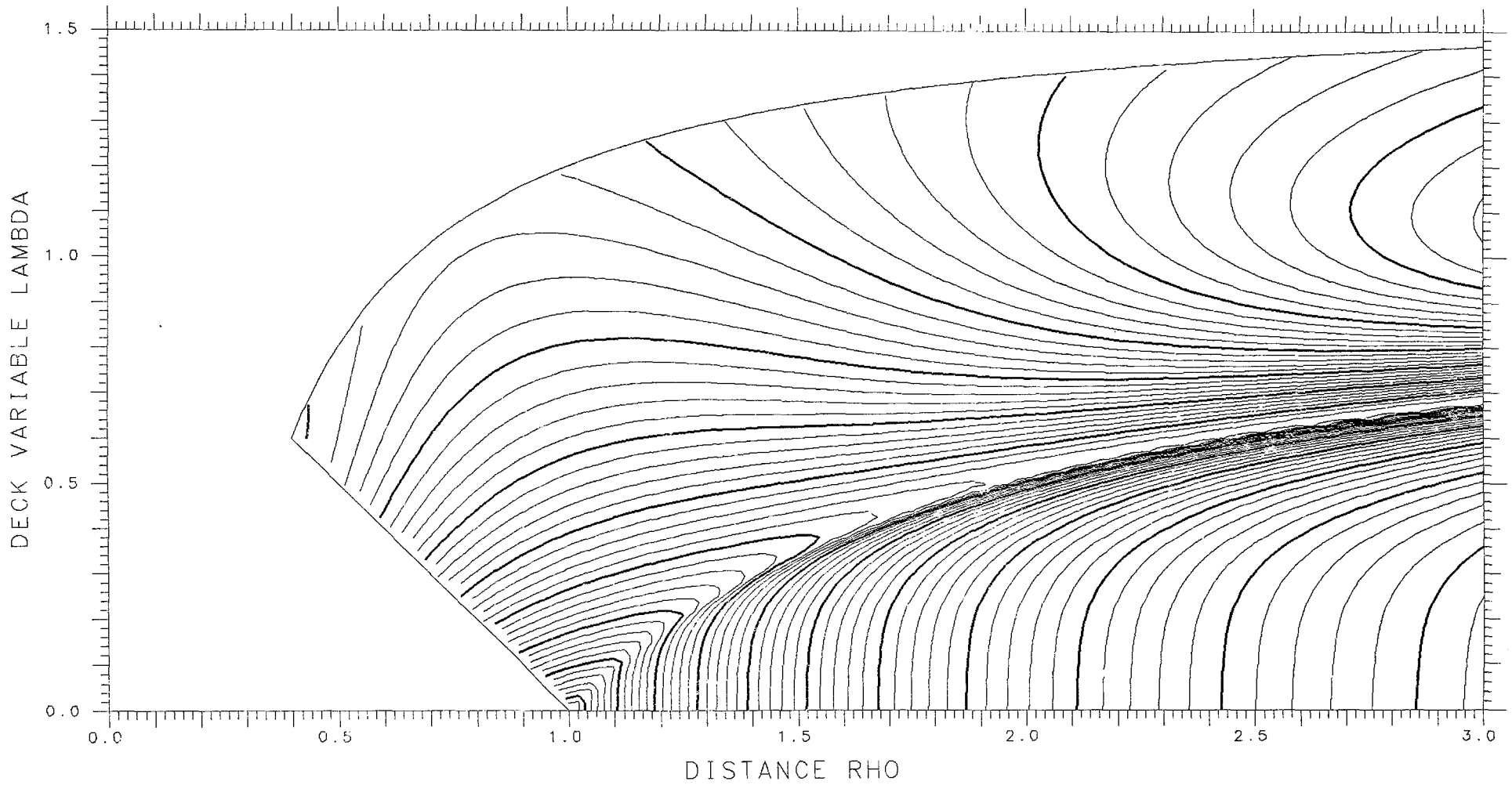

X= .300 ASYMMETRY DELTA= .175 FRACTIONAL= .7429

SPHERES .05259 TANGENT .17650 LENGTH 7.976 ENERGY 313.27 SPACING .005 SADDLE .15768

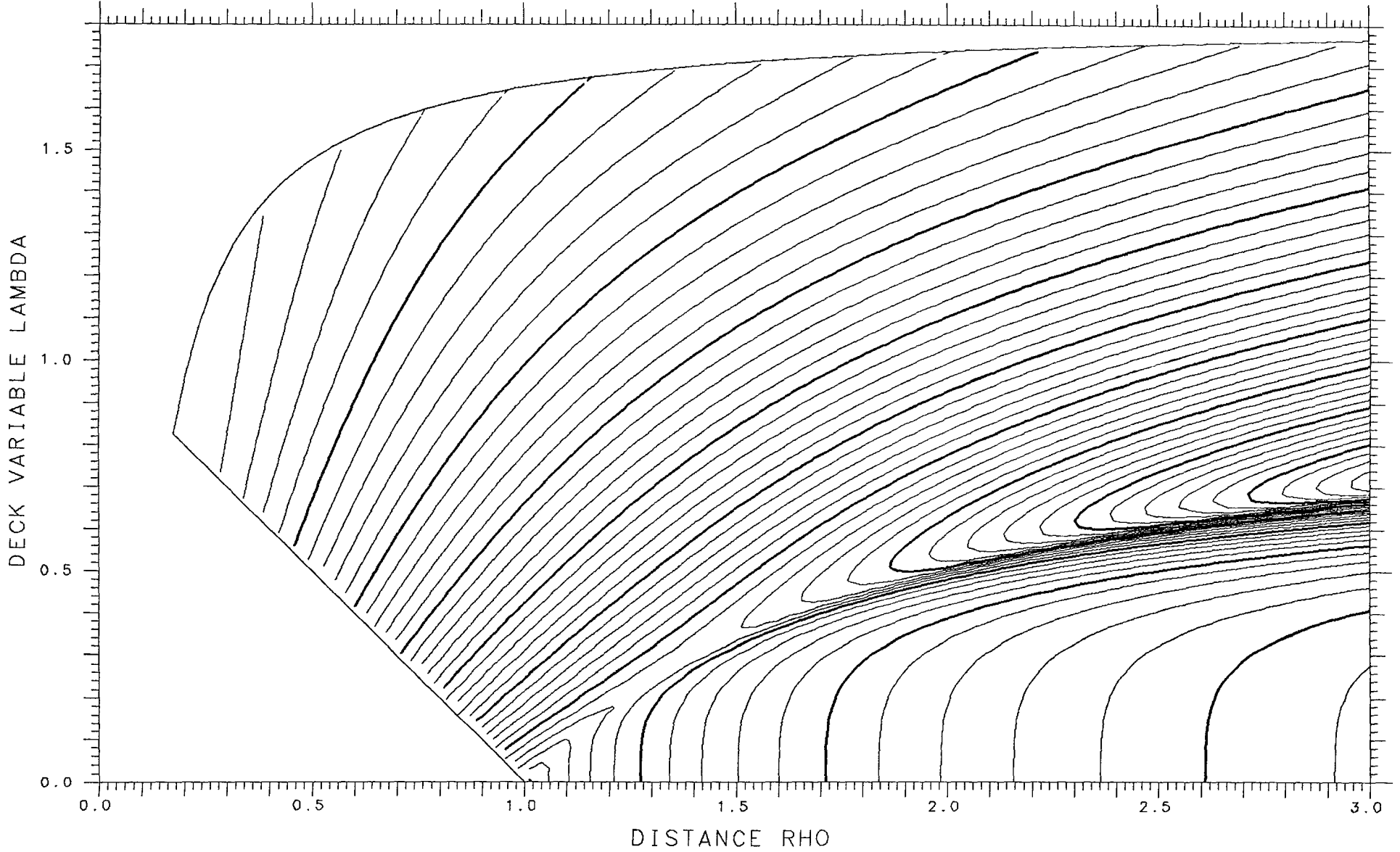

X=1.000 ASYMMETRY DELTA= .375 FRACTIONAL= .9141

SPHERES -.10796 TANGENT .07735 LENGTH 11.820 ENERGY 747.97 SPACING .002

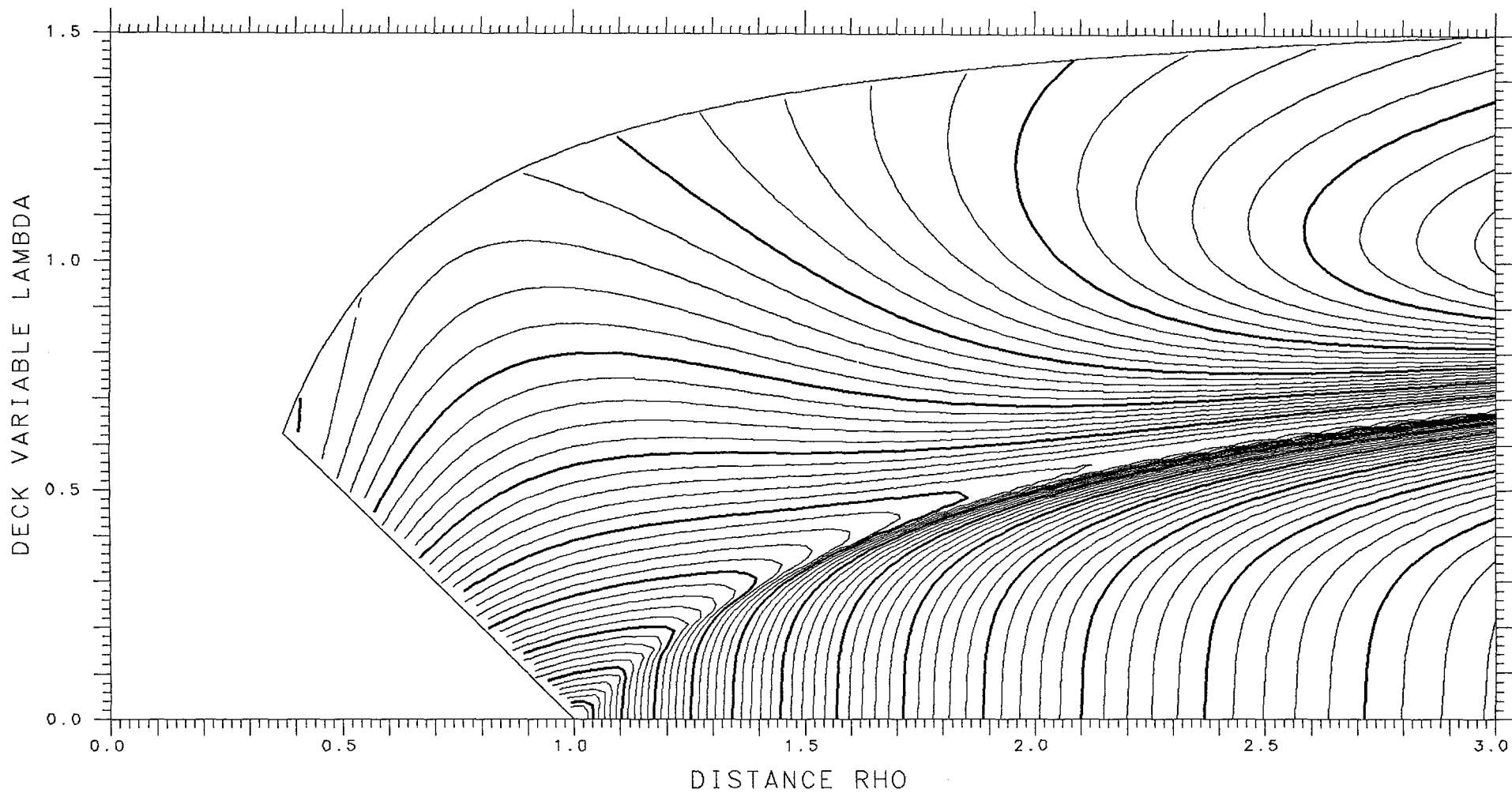

X= .300 ASYMMETRY DELTA= .200 FRACTIONAL= .7714

SPHERES .05556 TANGENT .17092 LENGTH 7.909 ENERGY 313.27 SPACING .005

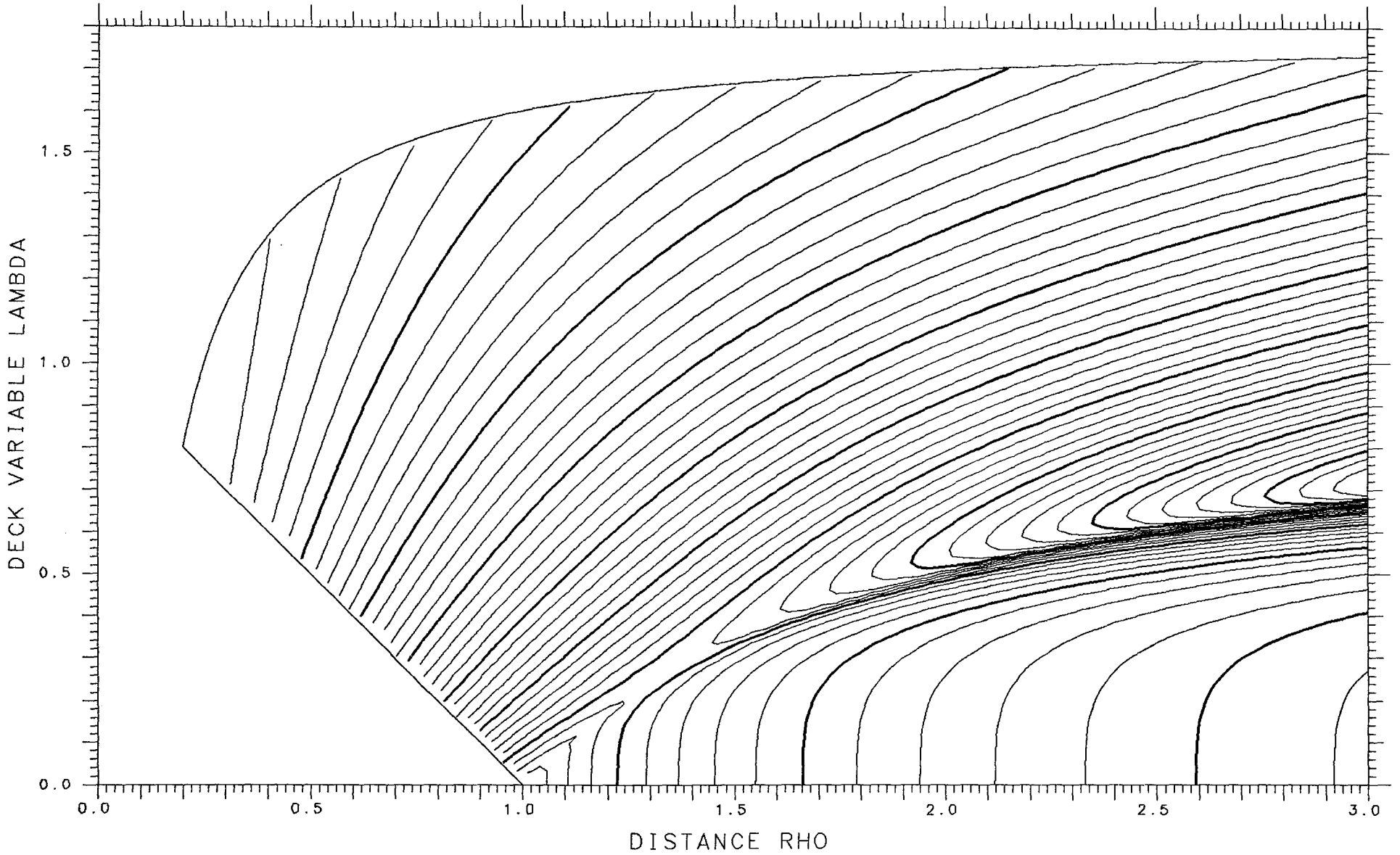

X=1.000 ASYMMETRY DELTA= .350 FRACTIONAL= .8996

SPHERES -.13207 TANGENT .07847 LENGTH 11.975 ENERGY 747.97 SPACING .002

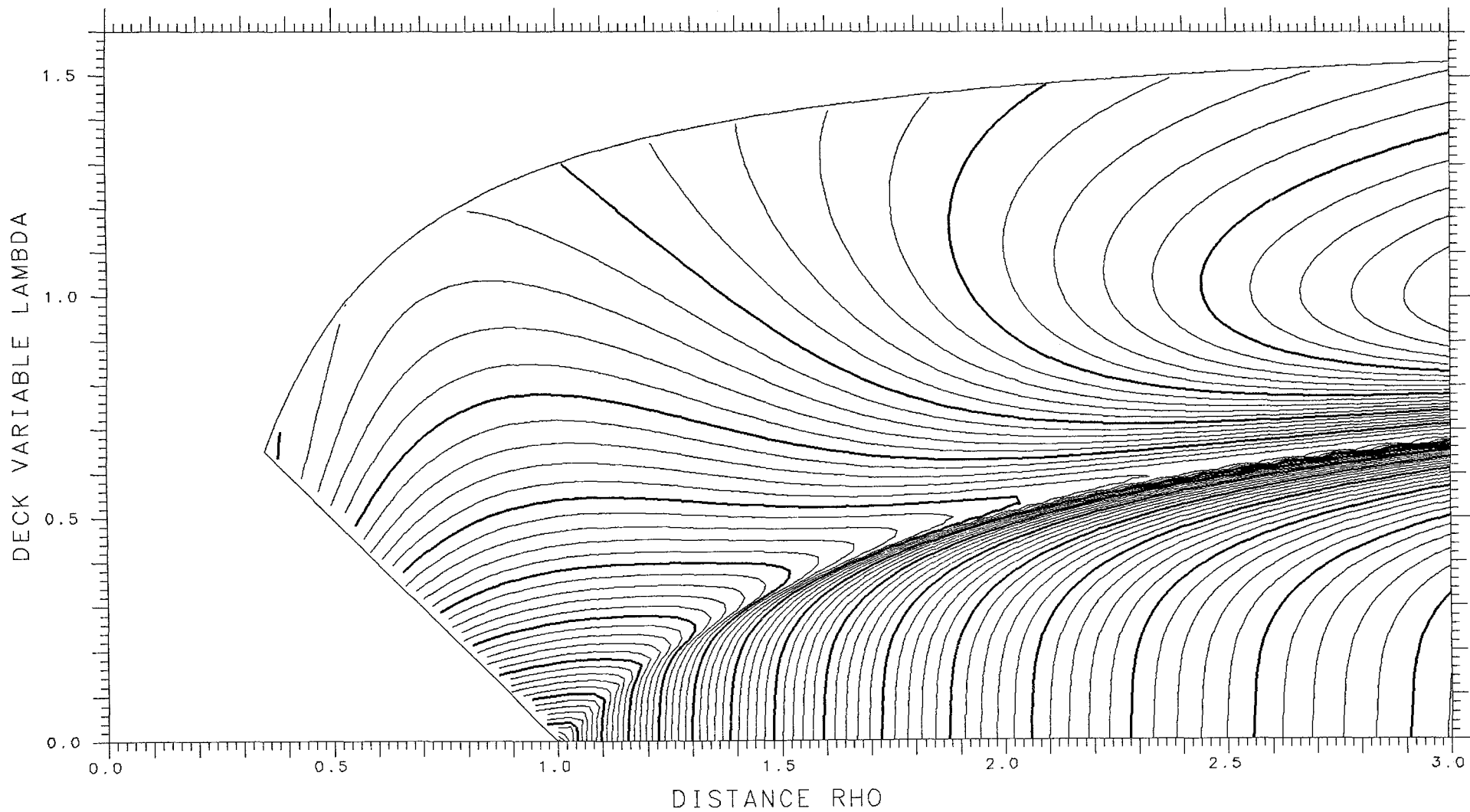

X= .300 ASYMMETRY DELTA= .225 FRACTIONAL= .7979

SPHERES .05826 TANGENT .16473 LENGTH 7.835 ENERGY 313.27 SPACING .005

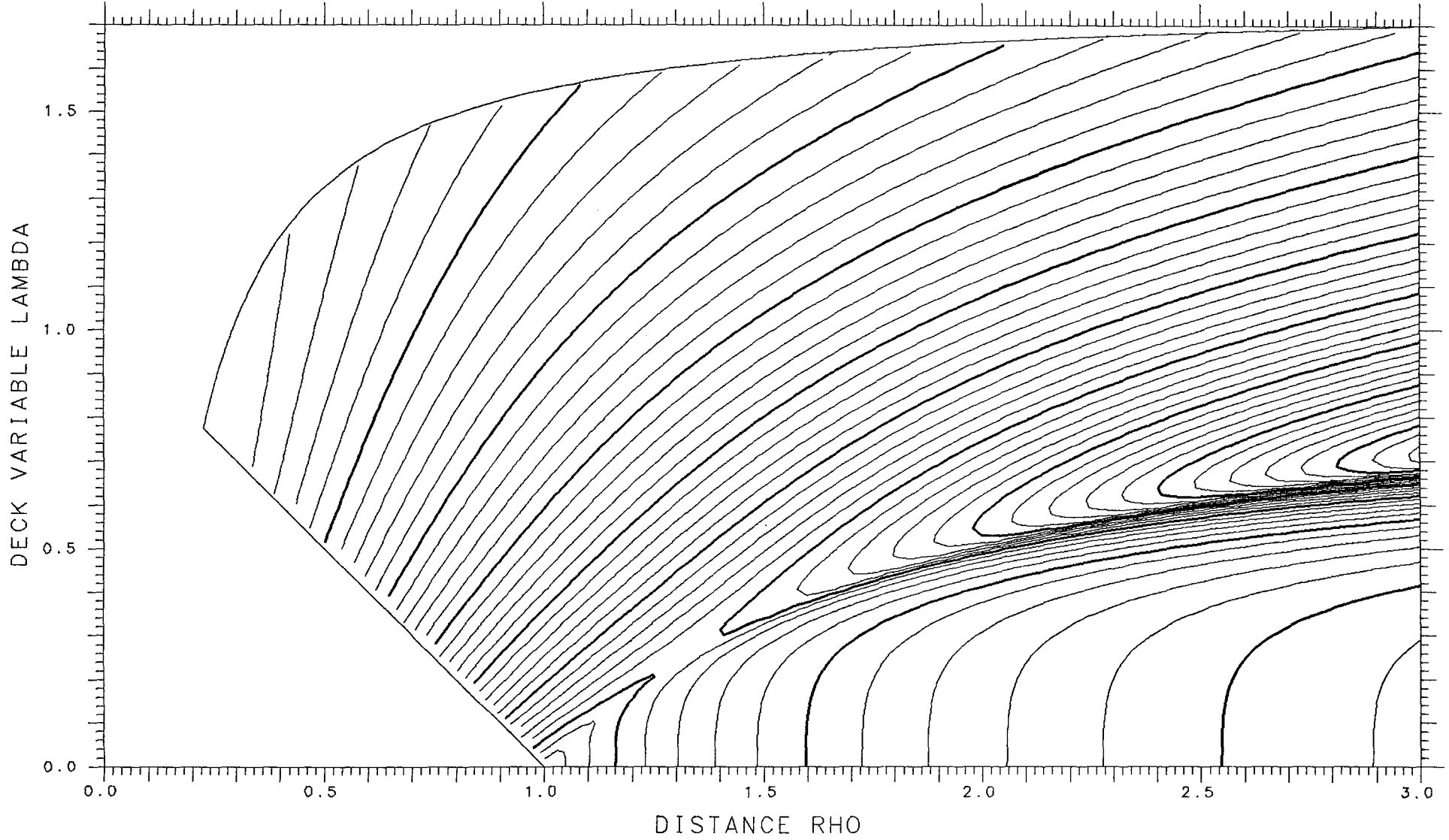

X=1.000

ASYMMETRY DELTA= .325

FRACTIONAL= .8832

SPHERES -.15863

TANGENT .07875

LENGTH 12.126

ENERGY 747.97

SPACING .002

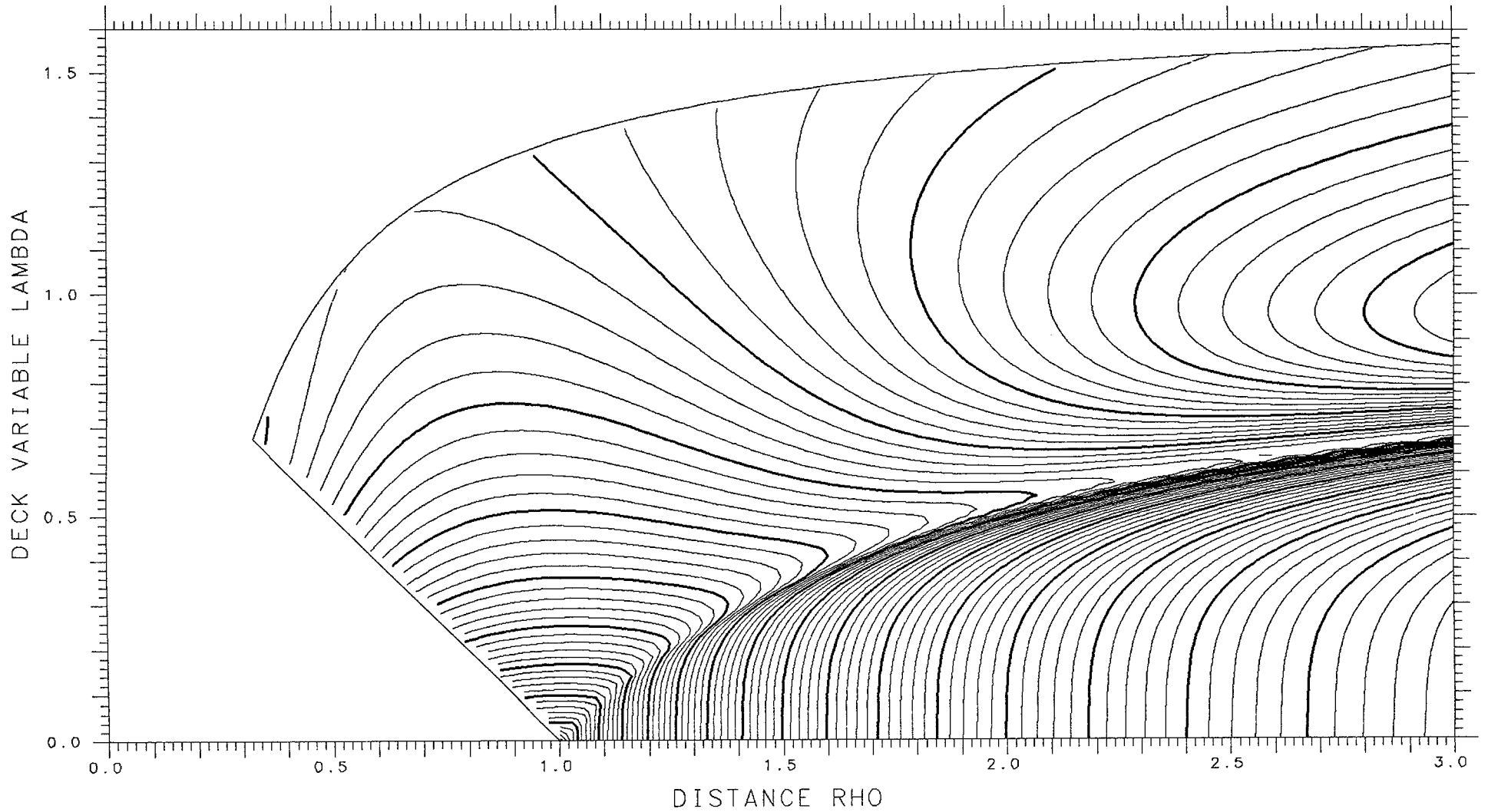

X= .300

ASYMMETRY DELTA= .250

FRACTIONAL= .8224

SPHERES .06054

TANGENT .15799

LENGTH 7.756

ENERGY 313.27

SPACING .005

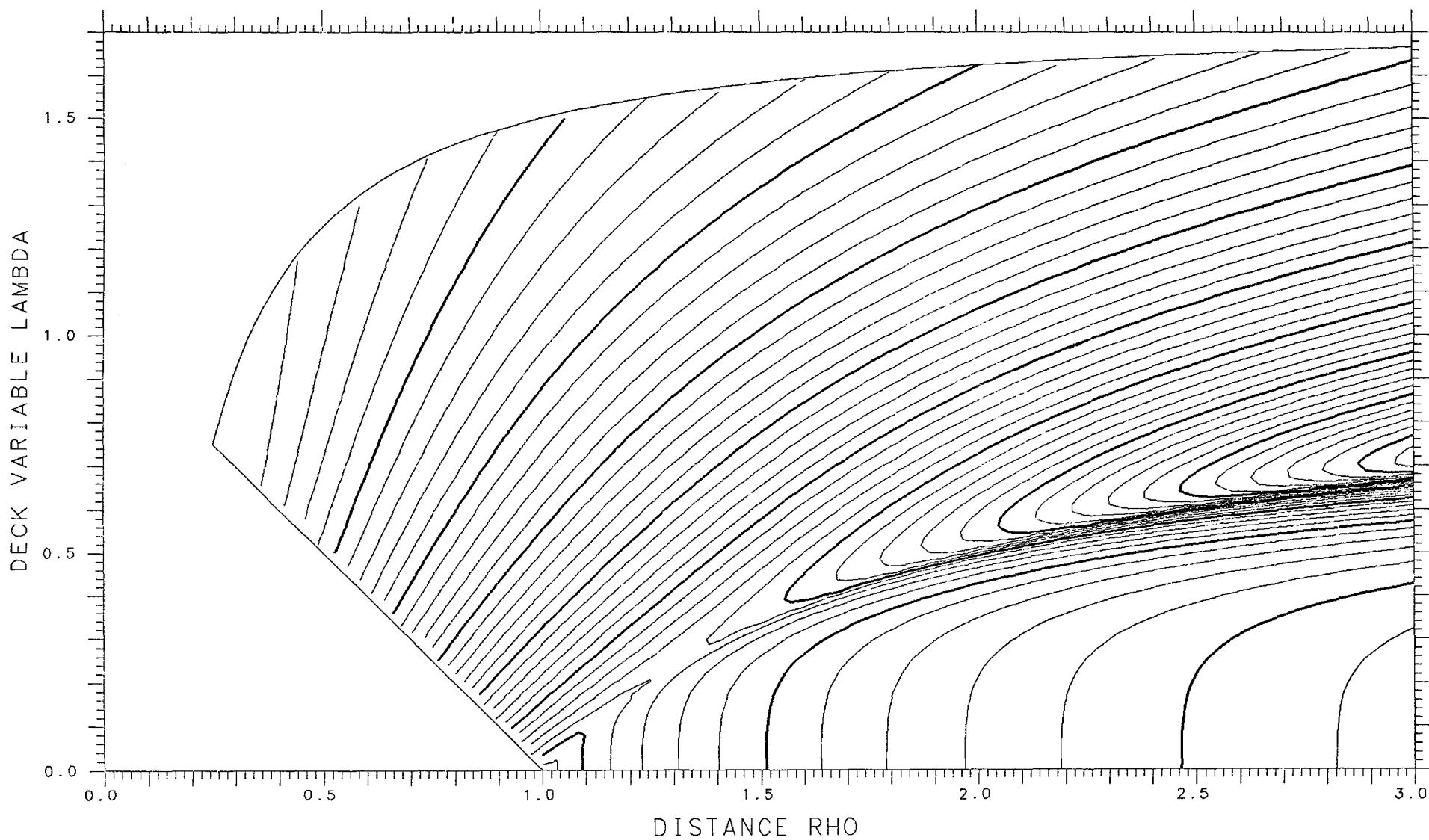

X=1.000 ASYMMETRY DELTA= .300 FRACTIONAL= .8650

SPHERES -.18743 TANGENT .07818 LENGTH 12.274 ENERGY 747.97 SPACING .002

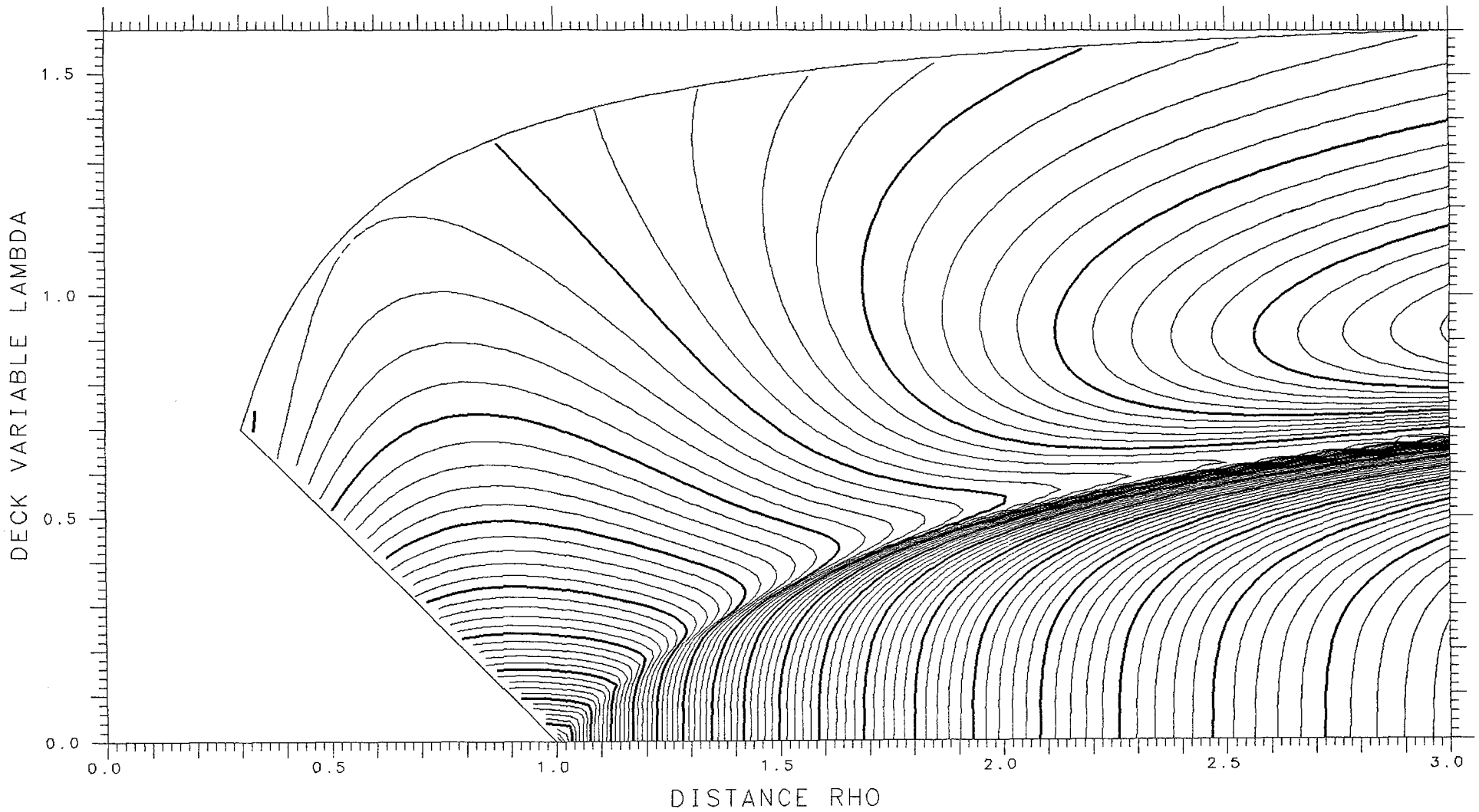

X= .300 ASYMMETRY DELTA= .275 FRACTIONAL= .8447

SPHERES .06231 TANGENT .15078 LENGTH 7.672 ENERGY 313.27 SPACING .005

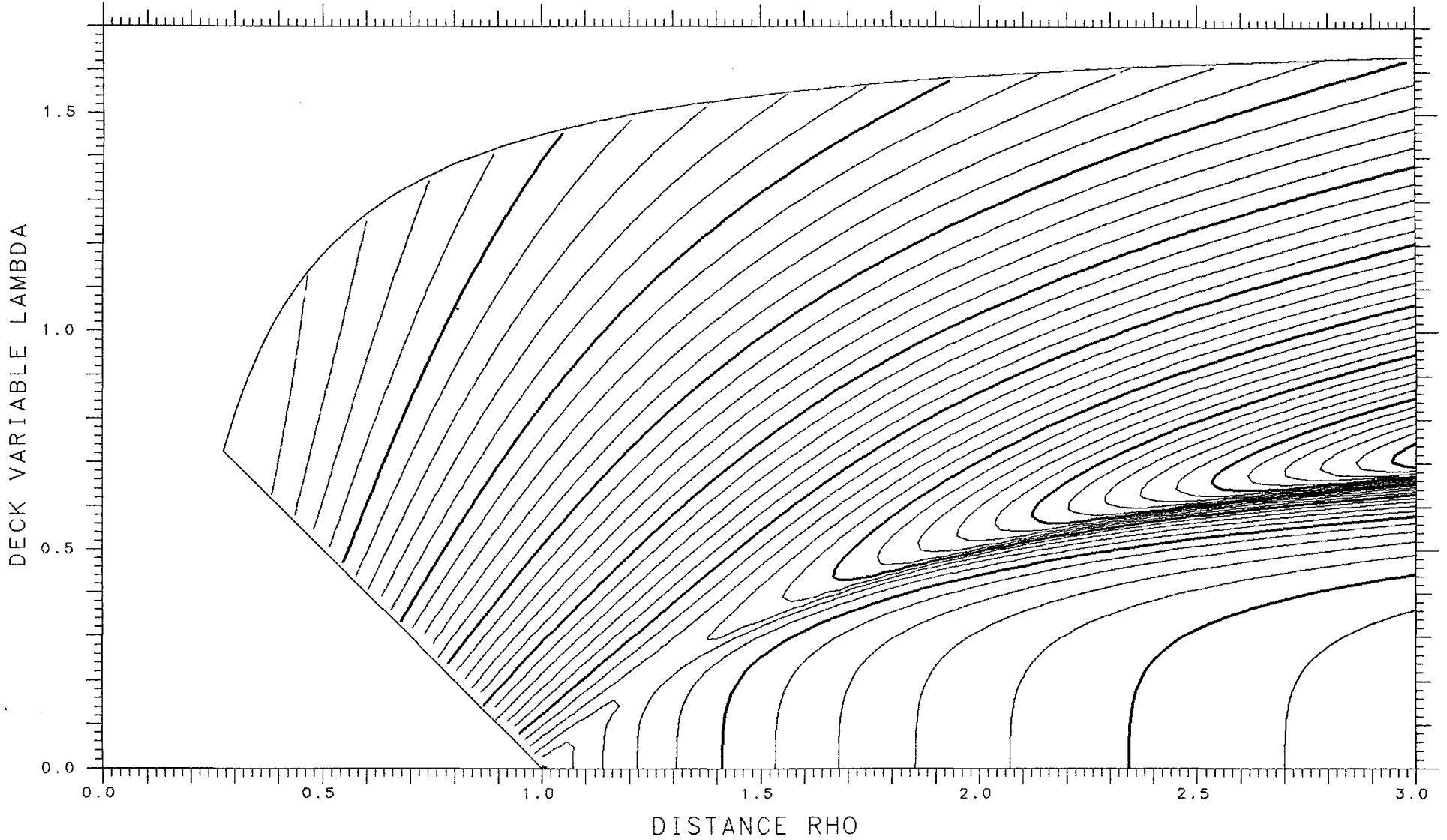

X=1.000 ASYMMETRY DELTA= .275 FRACTIONAL= .8447

SPHERES -.21814 TANGENT .07676 LENGTH 12.416 ENERGY 747.97 SPACING .002

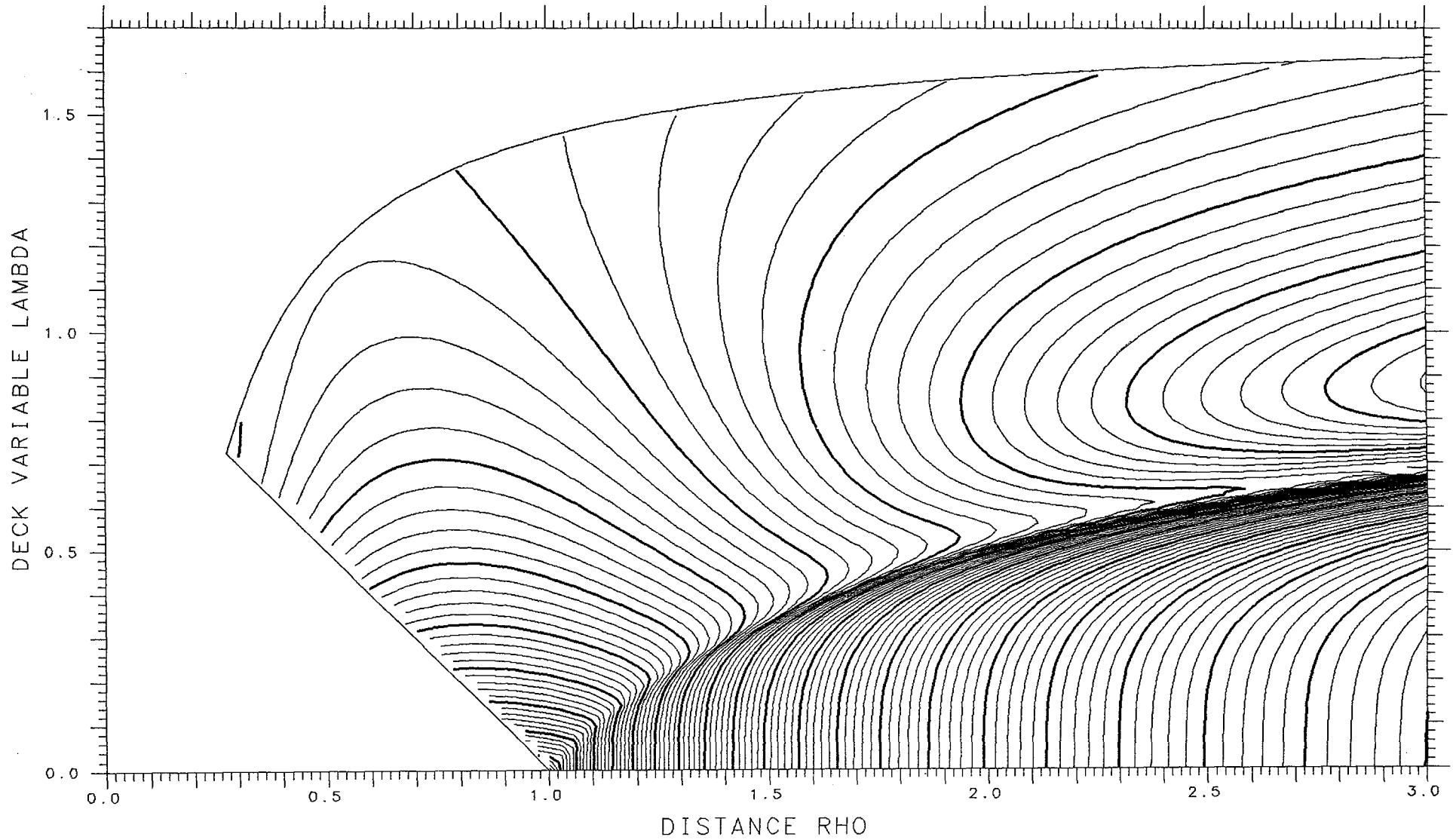

X= .300 ASYMMETRY DELTA= .300 FRACTIONAL= .8650

SPHERES .06349 TANGENT .14317 LENGTH 7.584 ENERGY 313.27 SPACING .005

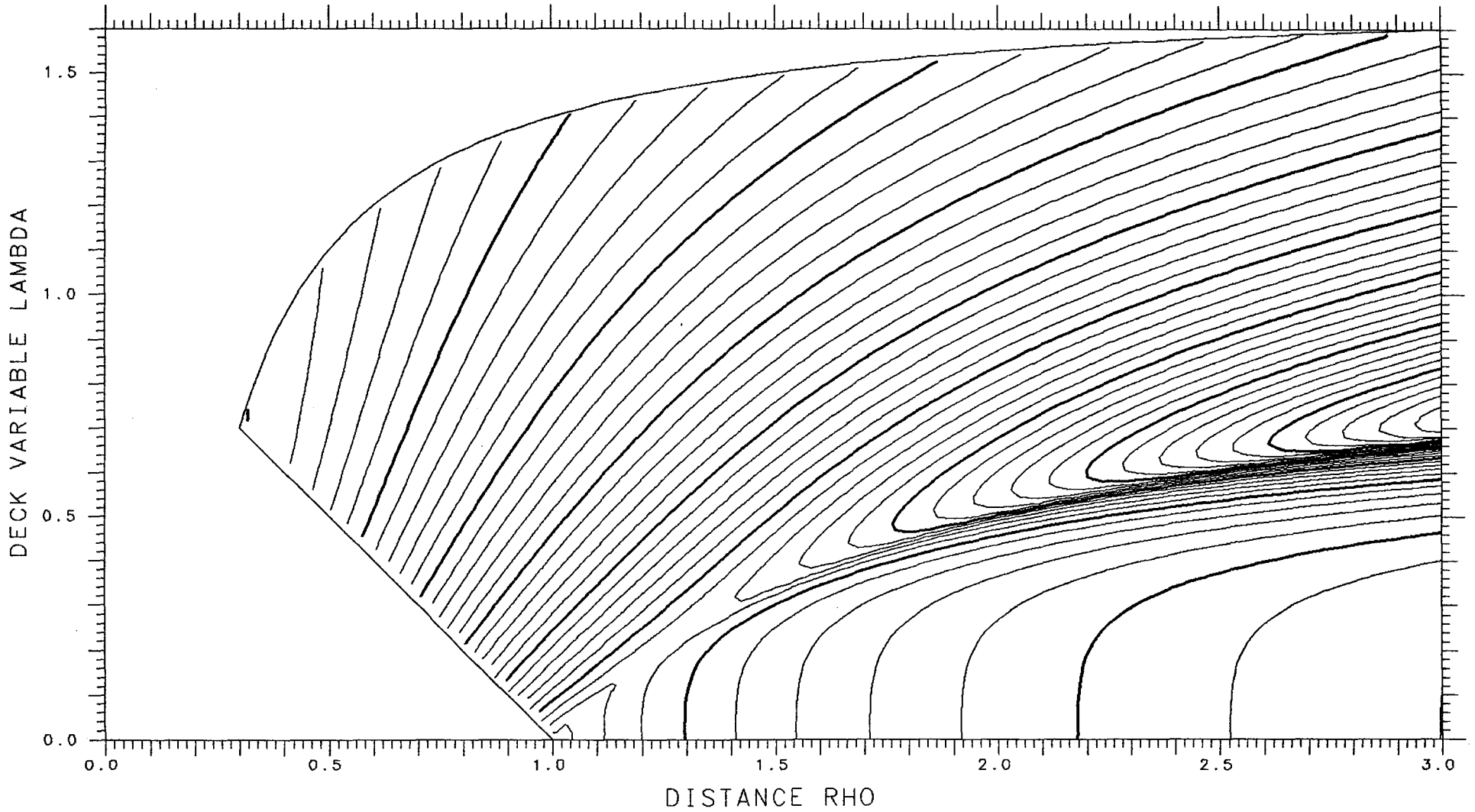

X=1.000 ASYMMETRY DELTA= .250 FRACTIONAL= .8224

SPHERES -.25029 TANGENT .07454 LENGTH 12.552 ENERGY 747.97 SPACING .002

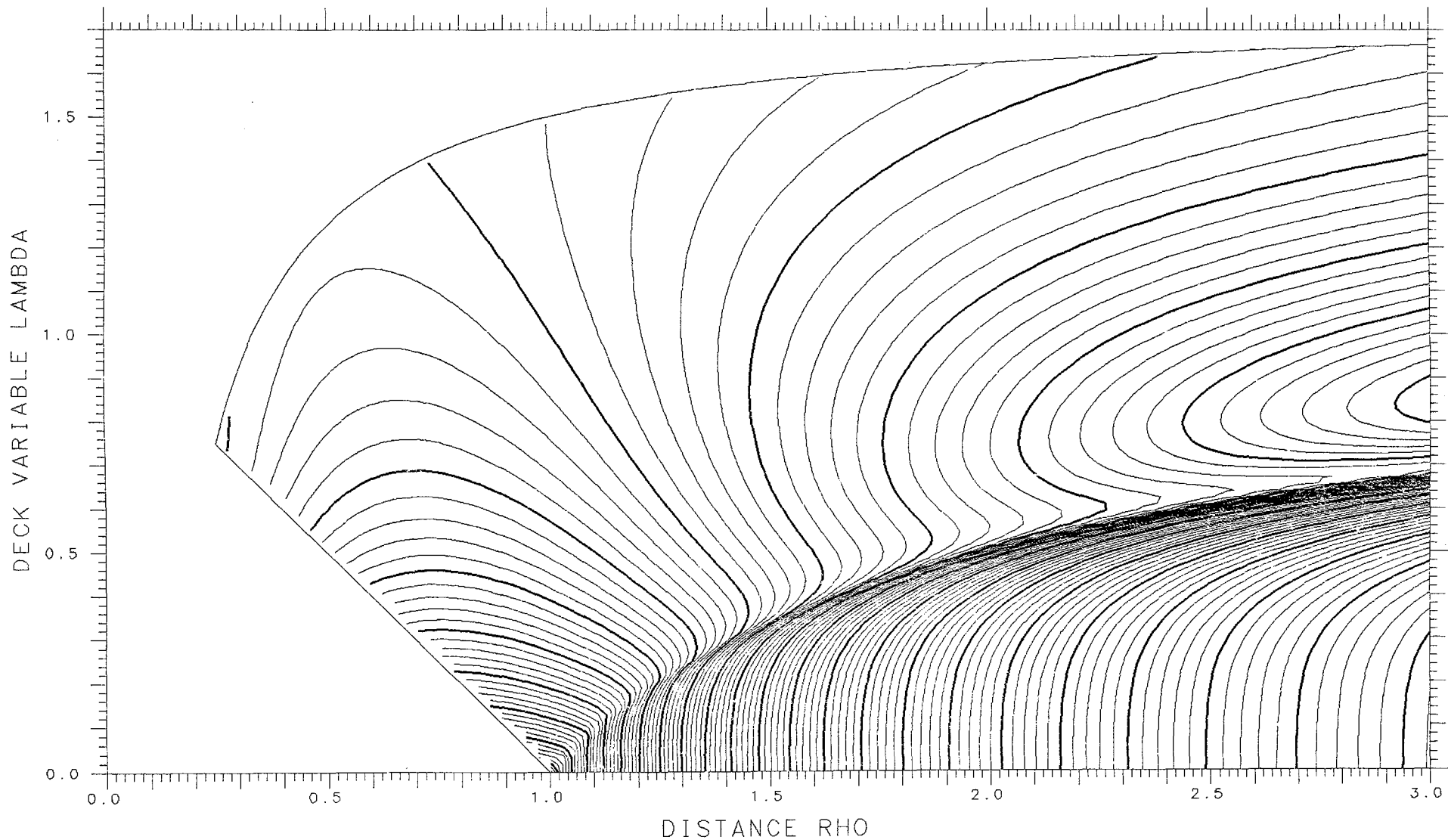

X= .300 ASYMMETRY DELTA= .325 FRACTIONAL= .8832

SPHERES .06403 TANGENT .13525 LENGTH 7.493 ENERGY 313.27 SPACING .005

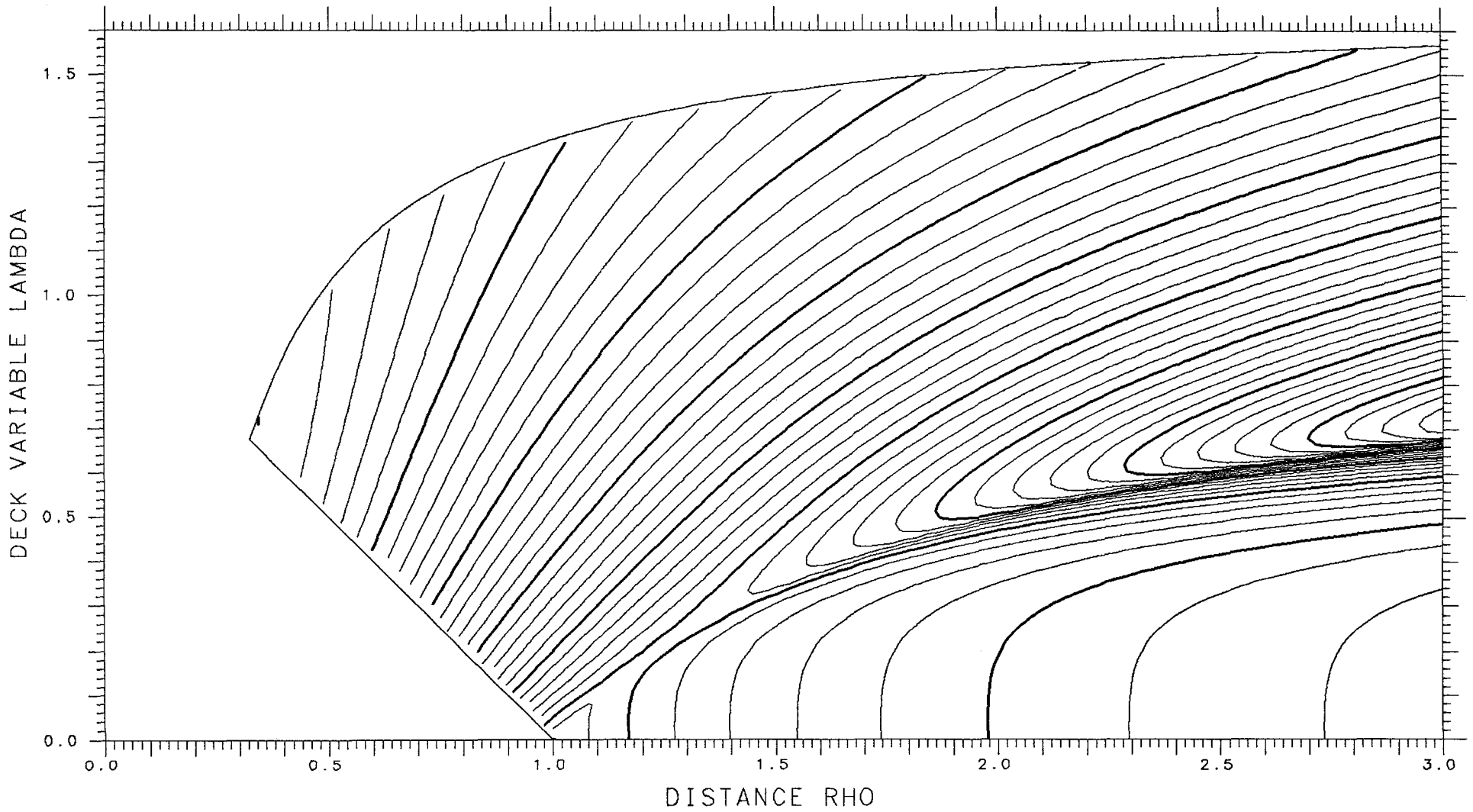

X=1.000

ASYMMETRY DELTA= .225

FRACTIONAL= .7979

SPHERES -.28328

TANGENT .07162

LENGTH 12.680

ENERGY 747.97

SPACING .002

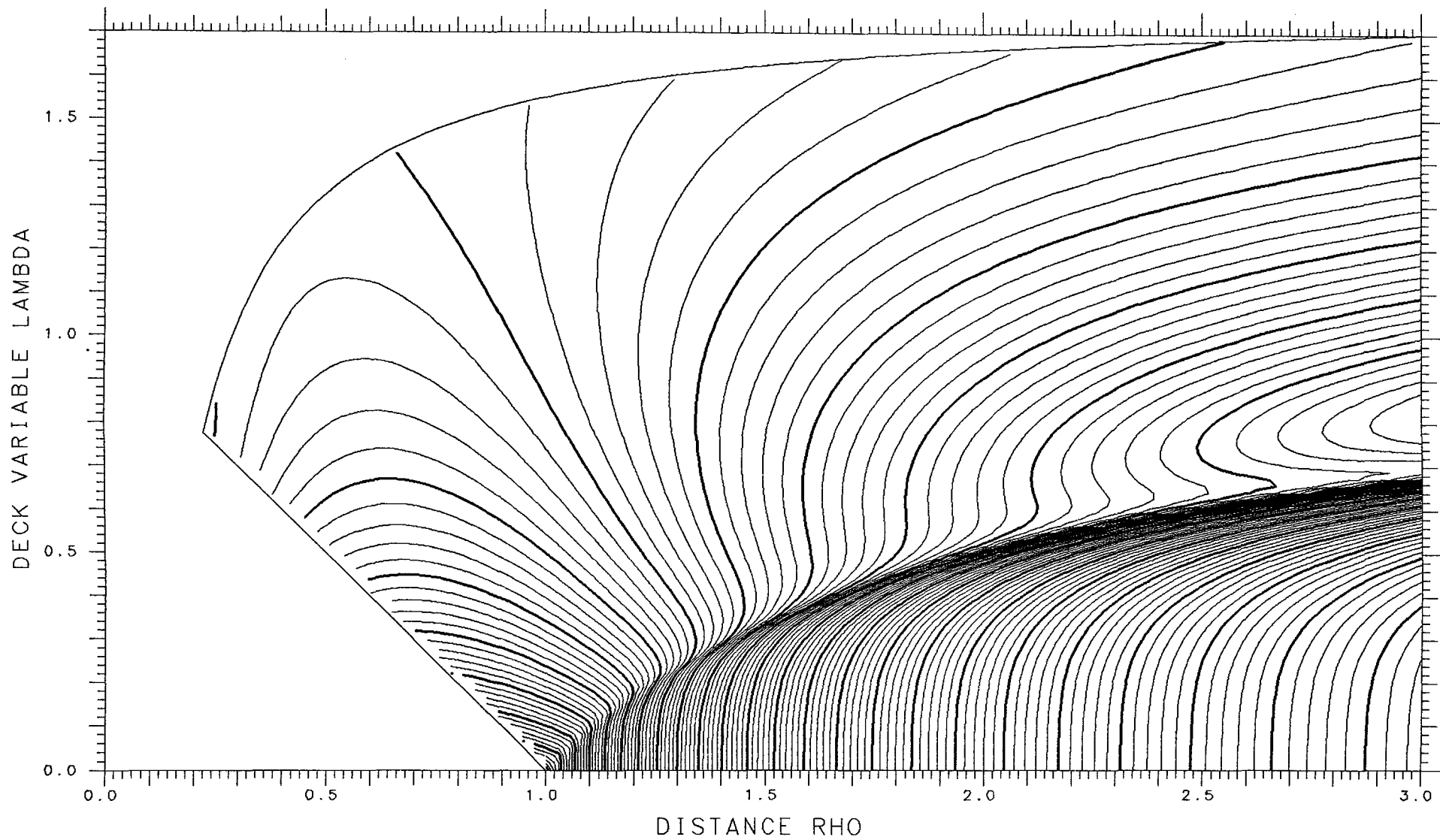

X= .300 ASYMMETRY DELTA= .350 FRACTIONAL= .8996

SPHERES .06392 TANGENT .12708 LENGTH 7.399 ENERGY 313.27 SPACING .005

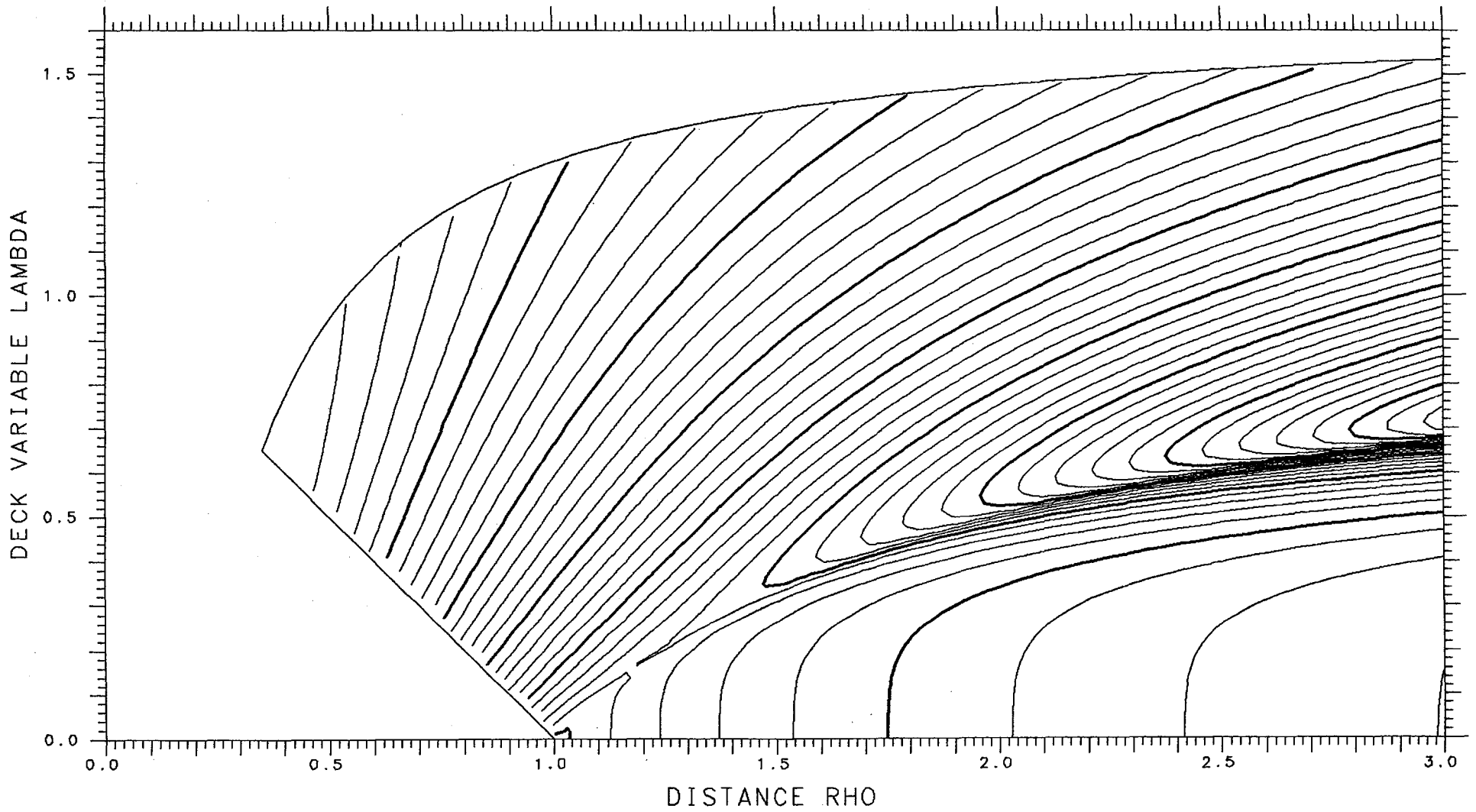

X=1.000

ASYMMETRY DELTA= .200

FRACTIONAL= .7714

SPHERES -.31639

TANGENT .06813

LENGTH 12.799

ENERGY 747.97

SPACING .002

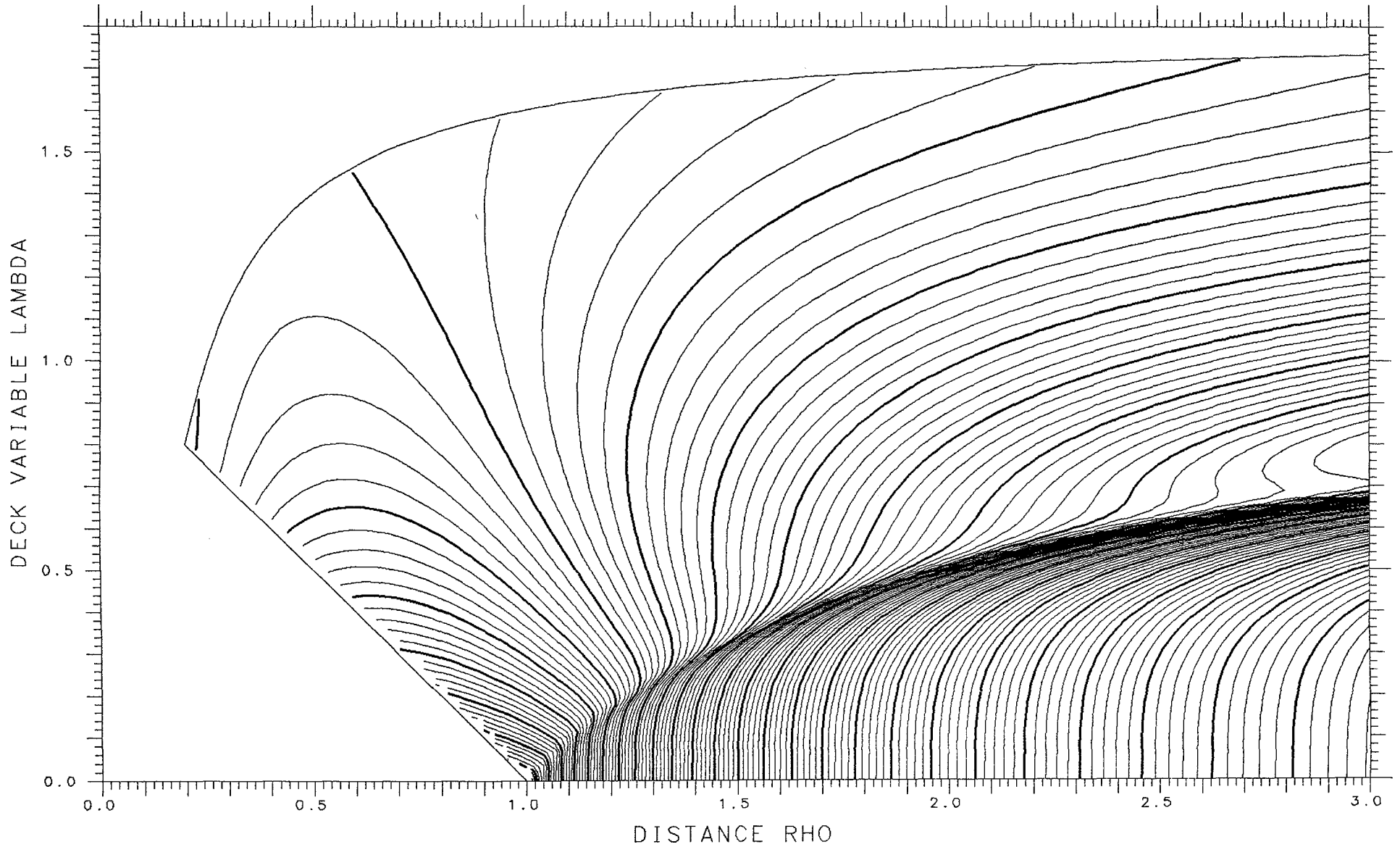

X= .300 ASYMMETRY DELTA= .375 FRACTIONAL= .9141

SPHERES .06318 TANGENT .11877 LENGTH 7.304 ENERGY 313.27 SPACING .005

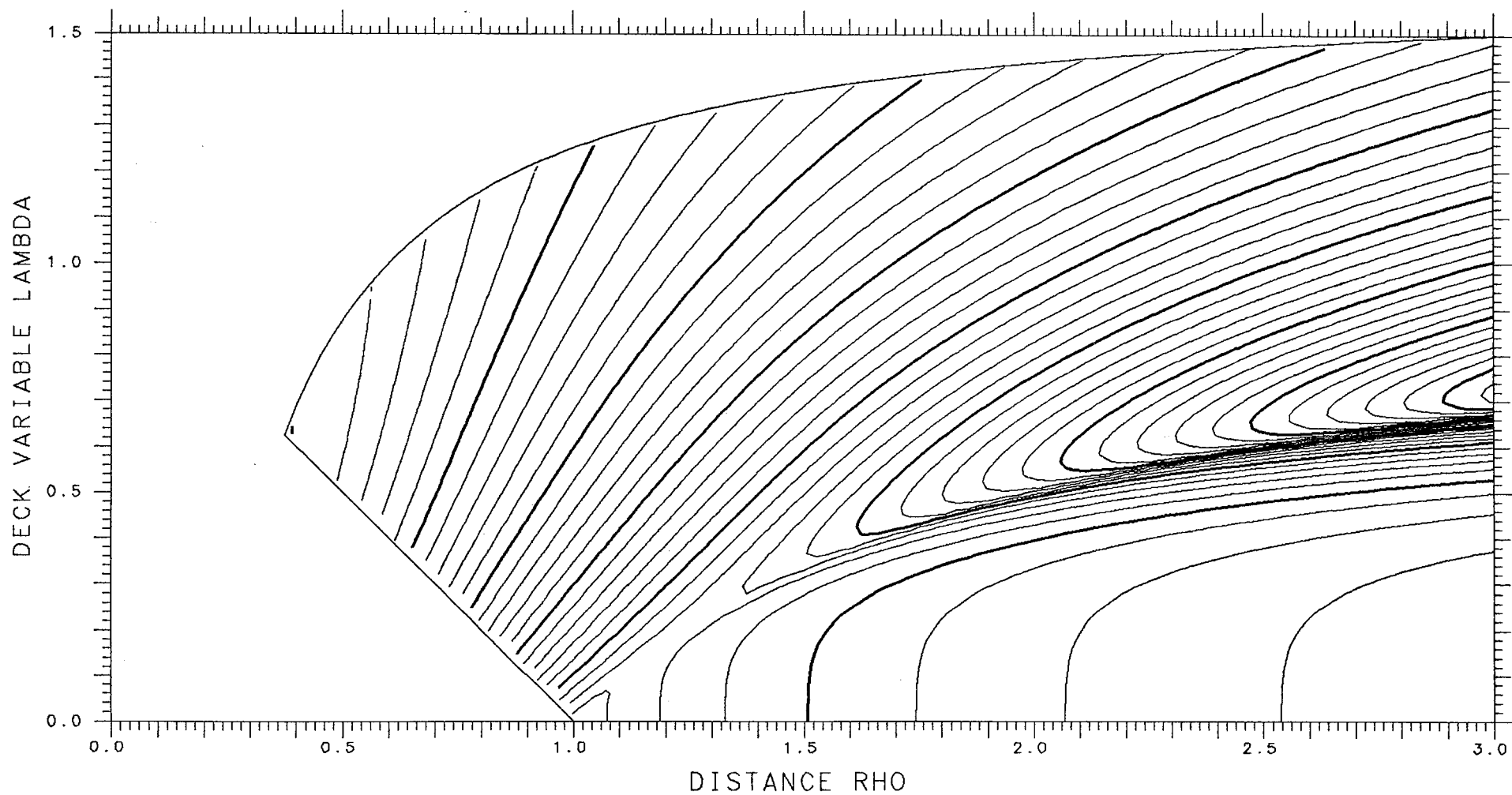

X=1.000

ASYMMETRY DELTA= .175

FRACTIONAL= .7429

SPHERES -.34879

TANGENT .06424

LENGTH 12.908

ENERGY 747.97

SPACING .002

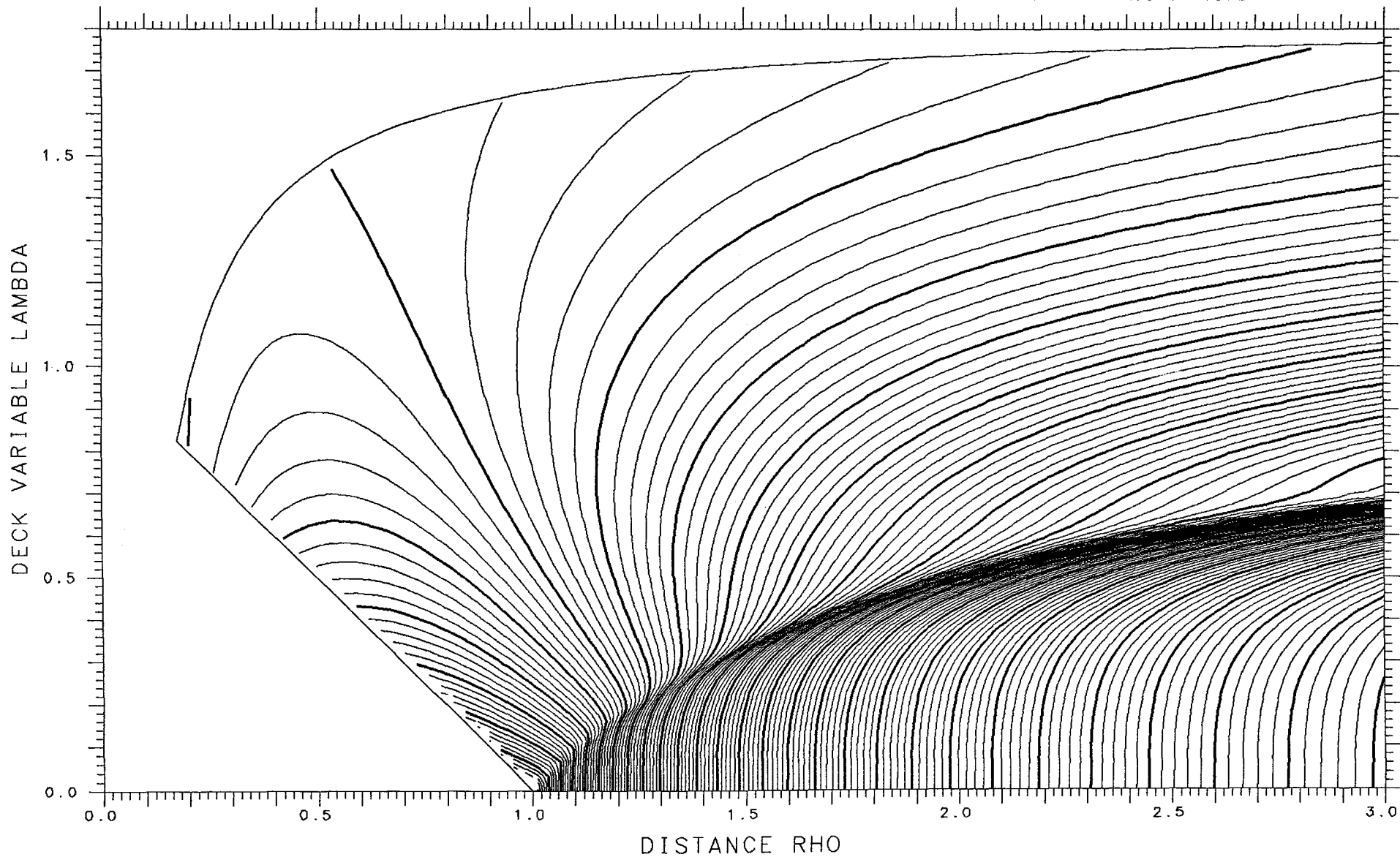

X= .300 ASYMMETRY DELTA= .400 FRACTIONAL= .9270

SPHERES .06183 TANGENT .11039 LENGTH 7.207 ENERGY 313.27 SPACING .005

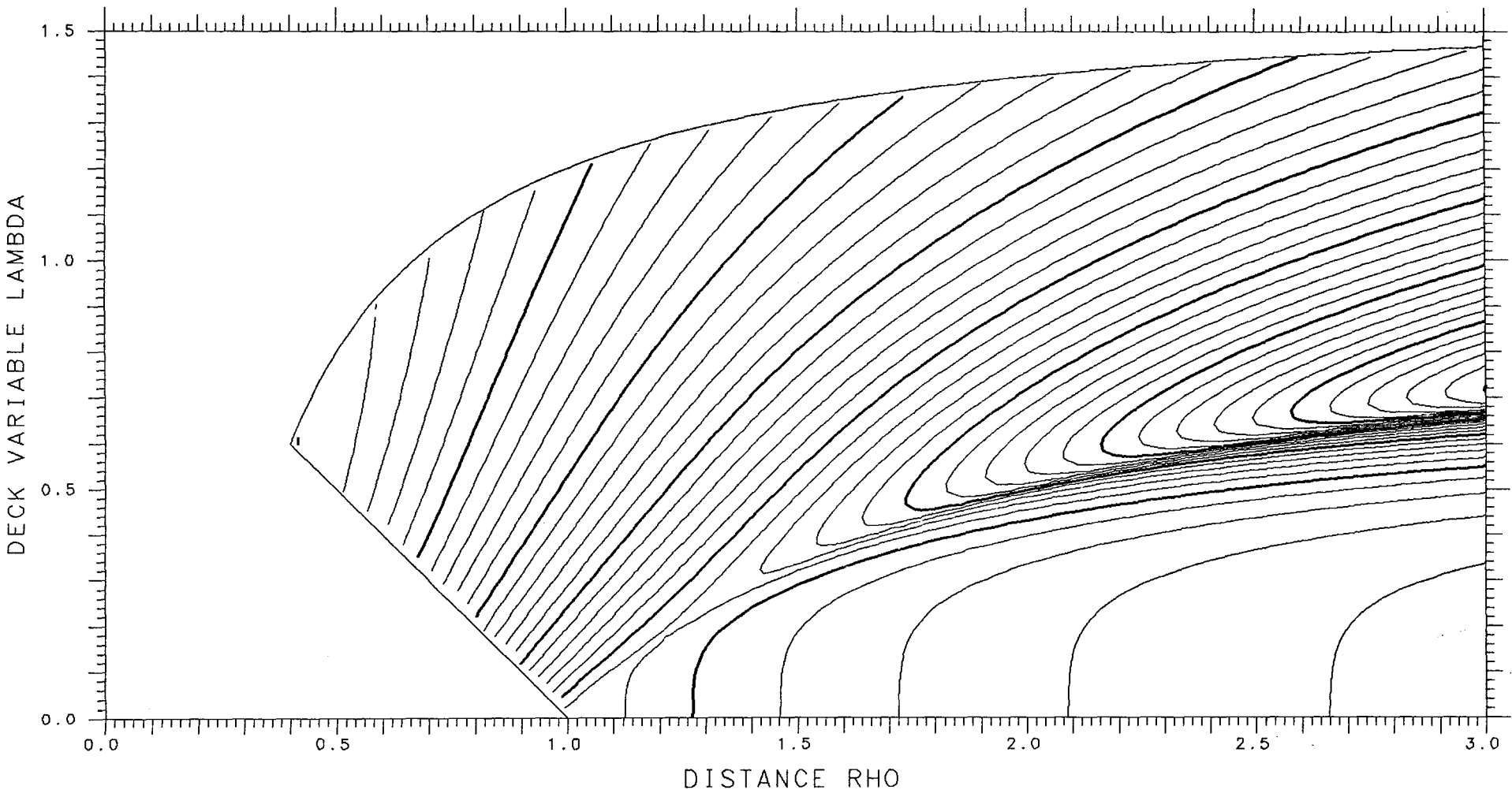

X=1.000

ASYMMETRY DELTA= .150

FRACTIONAL= .7124

SPHERES -.37956

TANGENT .06018

LENGTH 13.006

ENERGY 747.97

SPACING .002

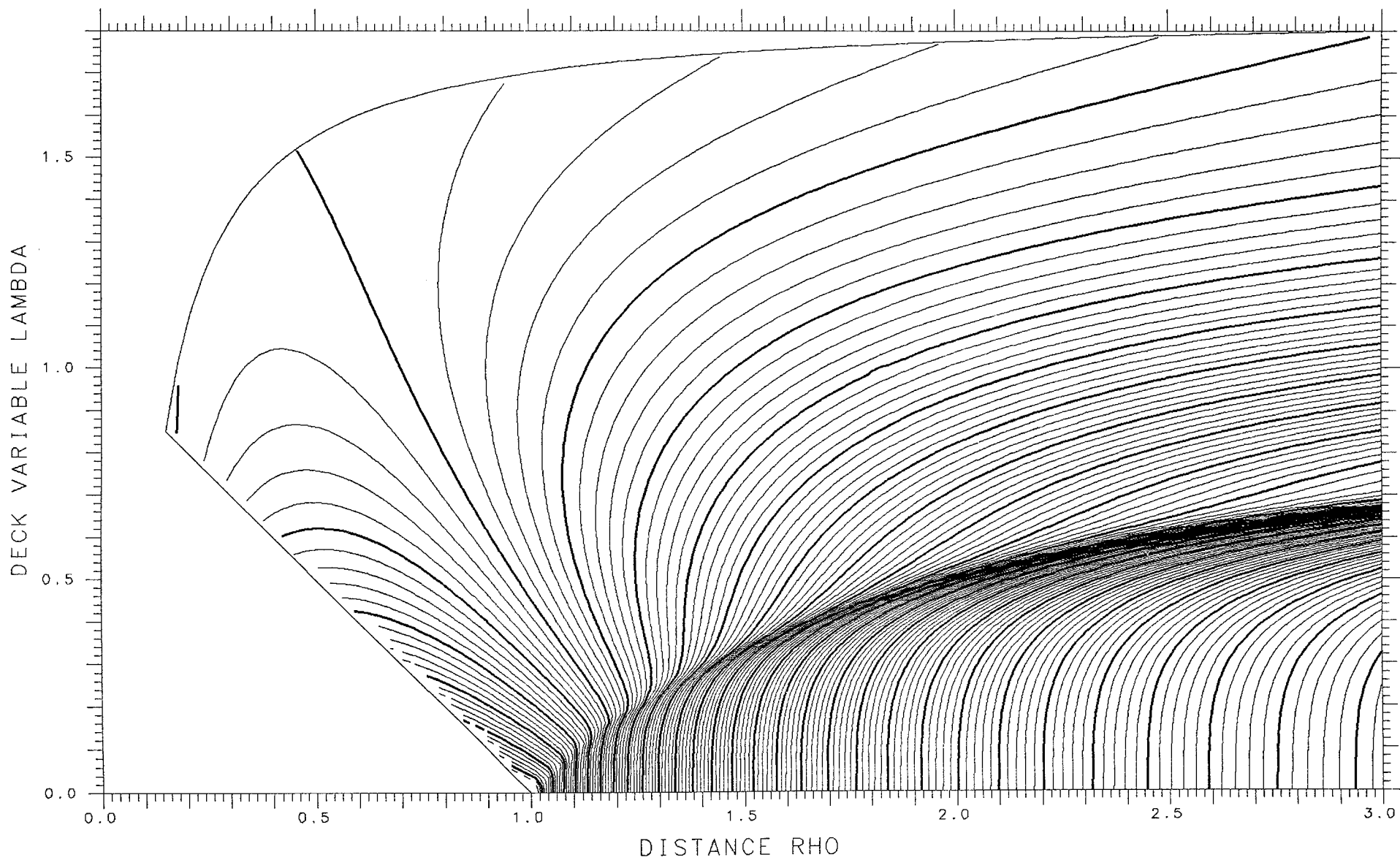

X= .300 ASYMMETRY DELTA= .425 FRACTIONAL= .9384

SPHERES .05992 TANGENT .10202 LENGTH 7.109 ENERGY 313.27 SPACING .005

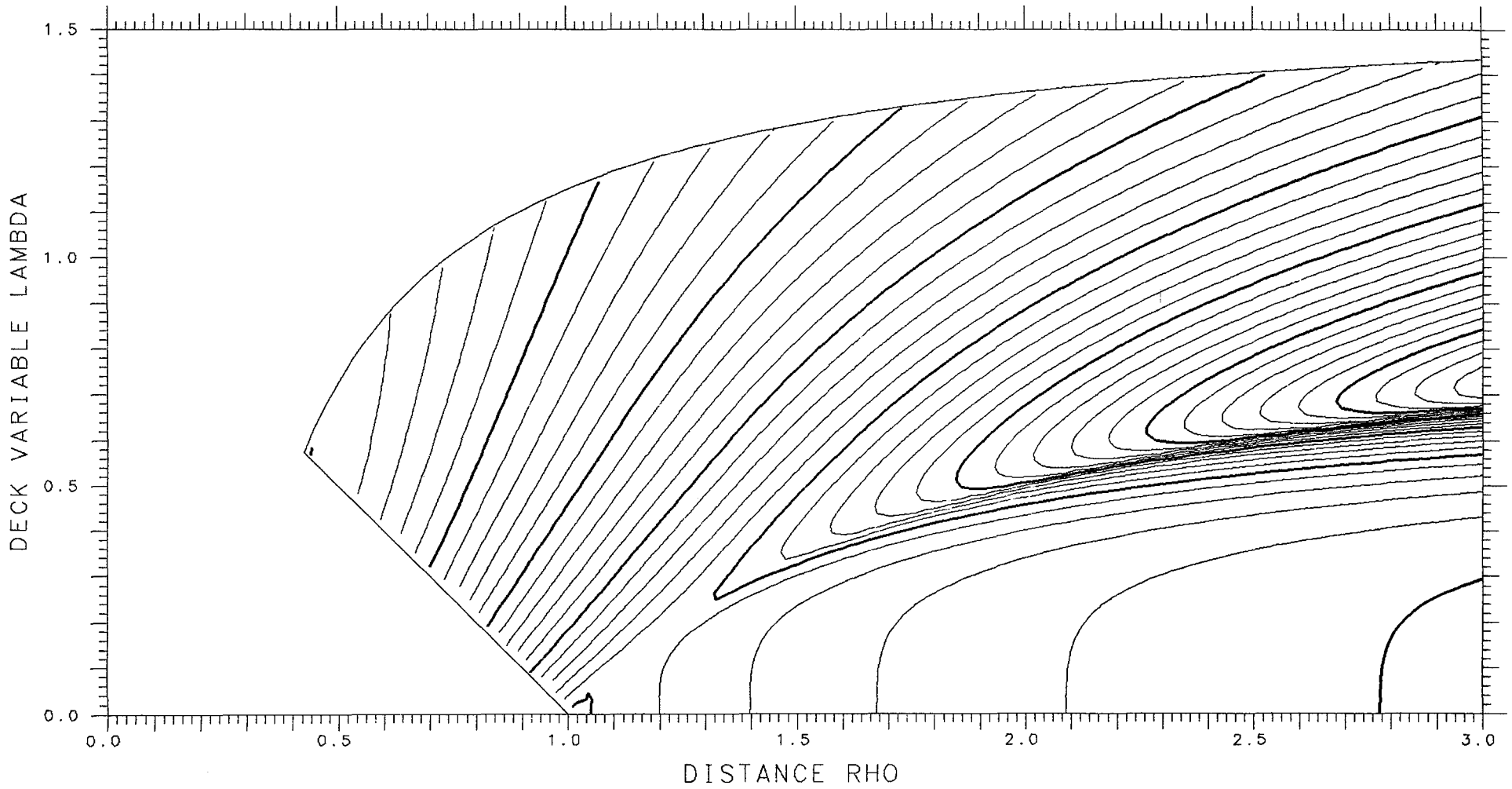

X=1.000

ASYMMETRY DELTA= .125

FRACTIONAL= .6800

SPHERES -.40776

TANGENT .05618

LENGTH 13.090

ENERGY 747.97

SPACING .002

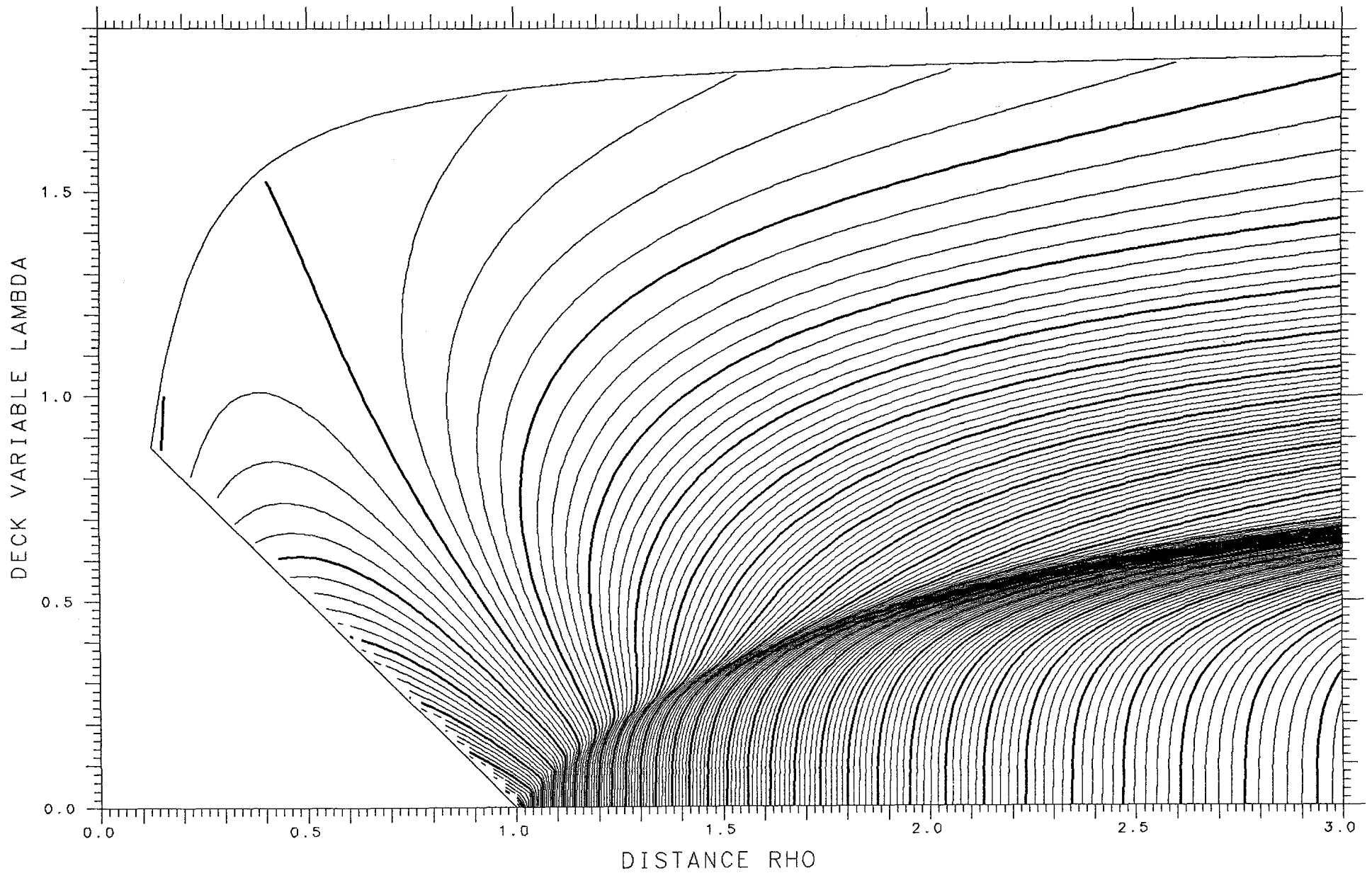

X= .300 ASYMMETRY DELTA= .450 FRACTIONAL= .9483

SPHERES .05752 TANGENT .09374 LENGTH 7.011 ENERGY 313.27 SPACING .005

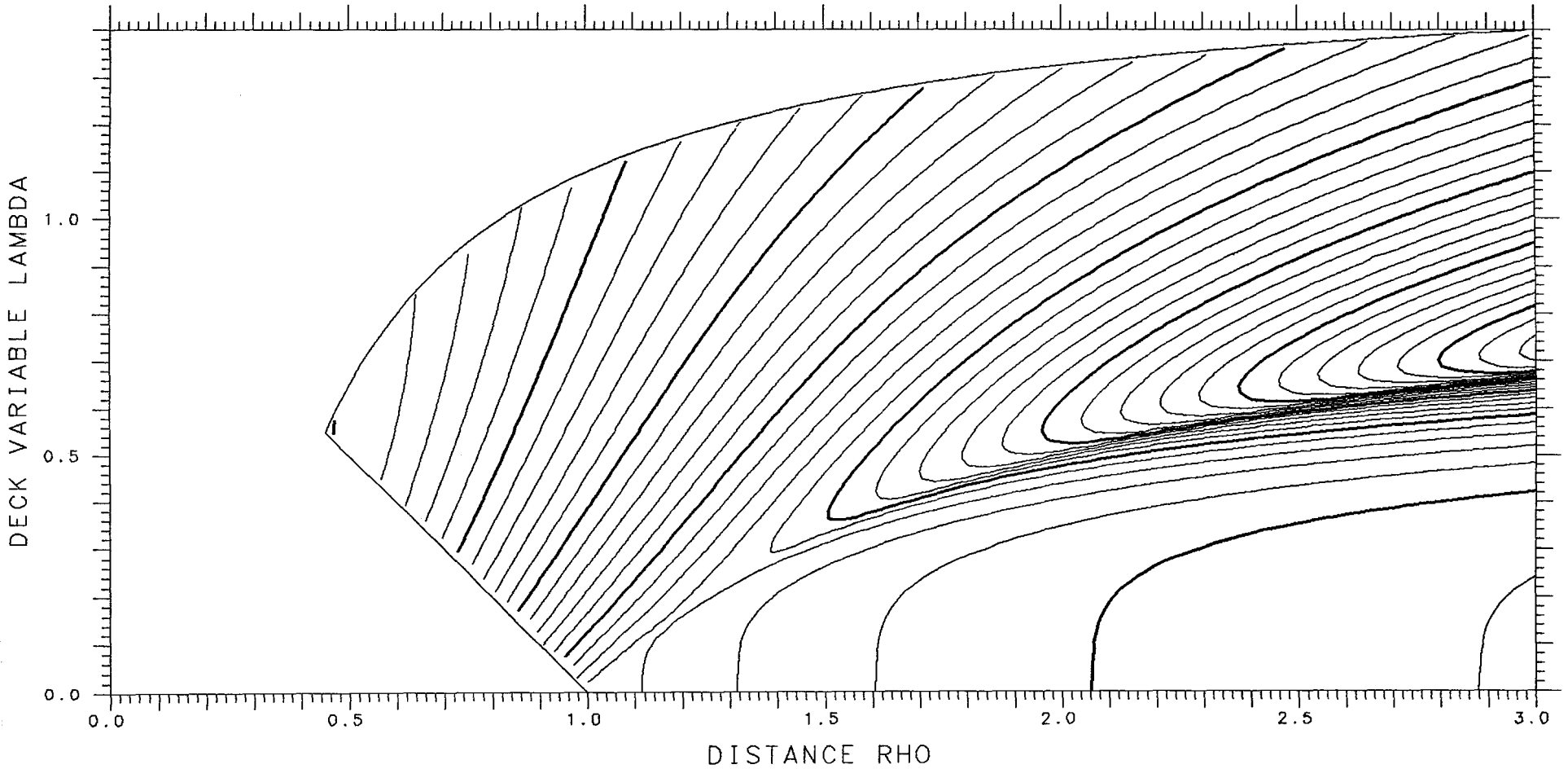

X=1.000

ASYMMETRY DELTA= .100

FRACTIONAL= .6461

SPHERES -.43242

TANGENT .05247

LENGTH 13.161

ENERGY 747.97

SPACING .002

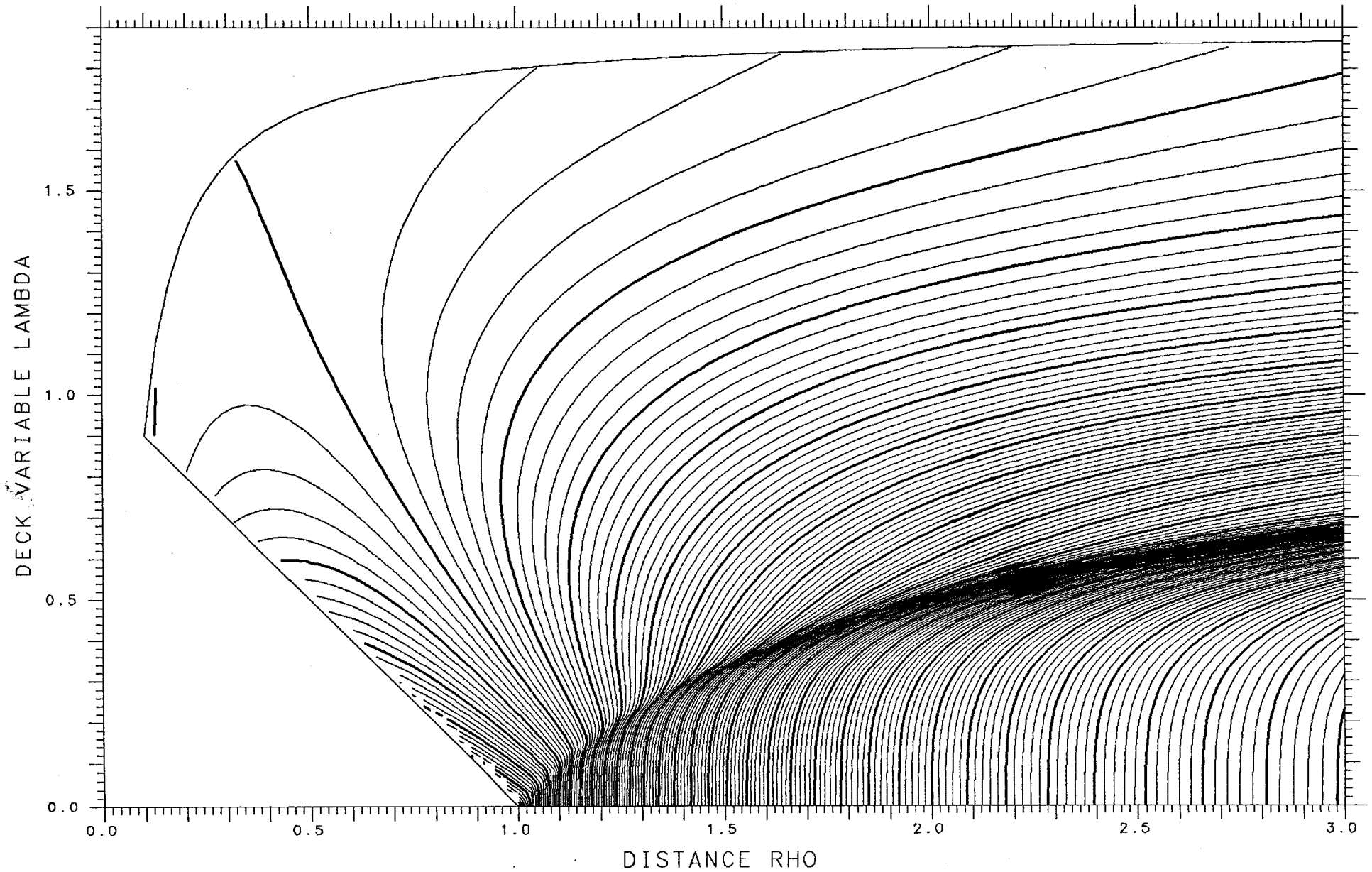

X= .350

ASYMMETRY DELTA=0.

FRACTIONAL= .5000

SPHERES .00089

TANGENT .18463

LENGTH 8.726

ENERGY 351.36

SPACING .005

SADDLE .15135

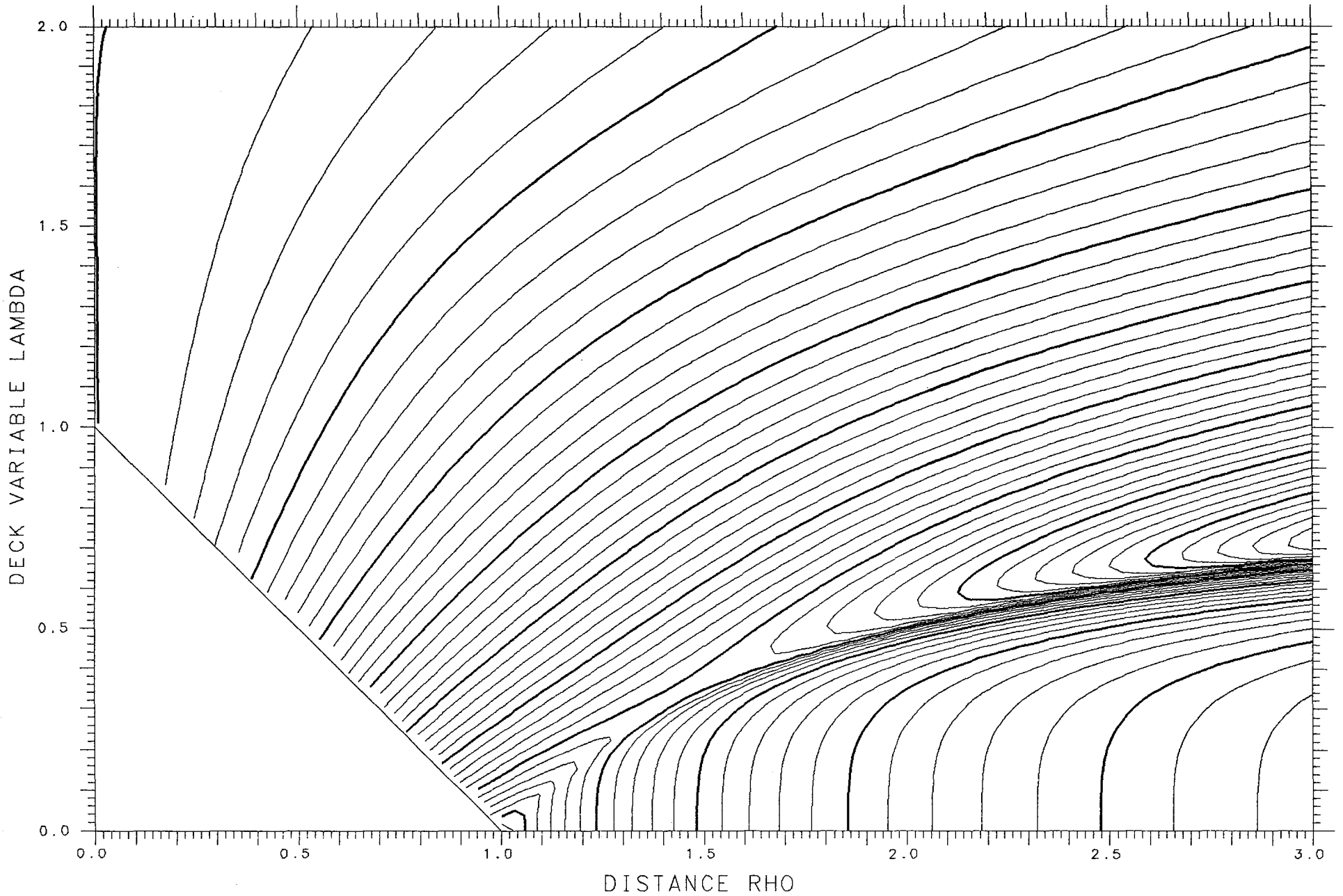

X=1.000

ASYMMETRY DELTA= .075

FRACTIONAL= .6108

SPHERES -.45267

TANGENT .04929

LENGTH 13.218

ENERGY 747.97

SPACING .002

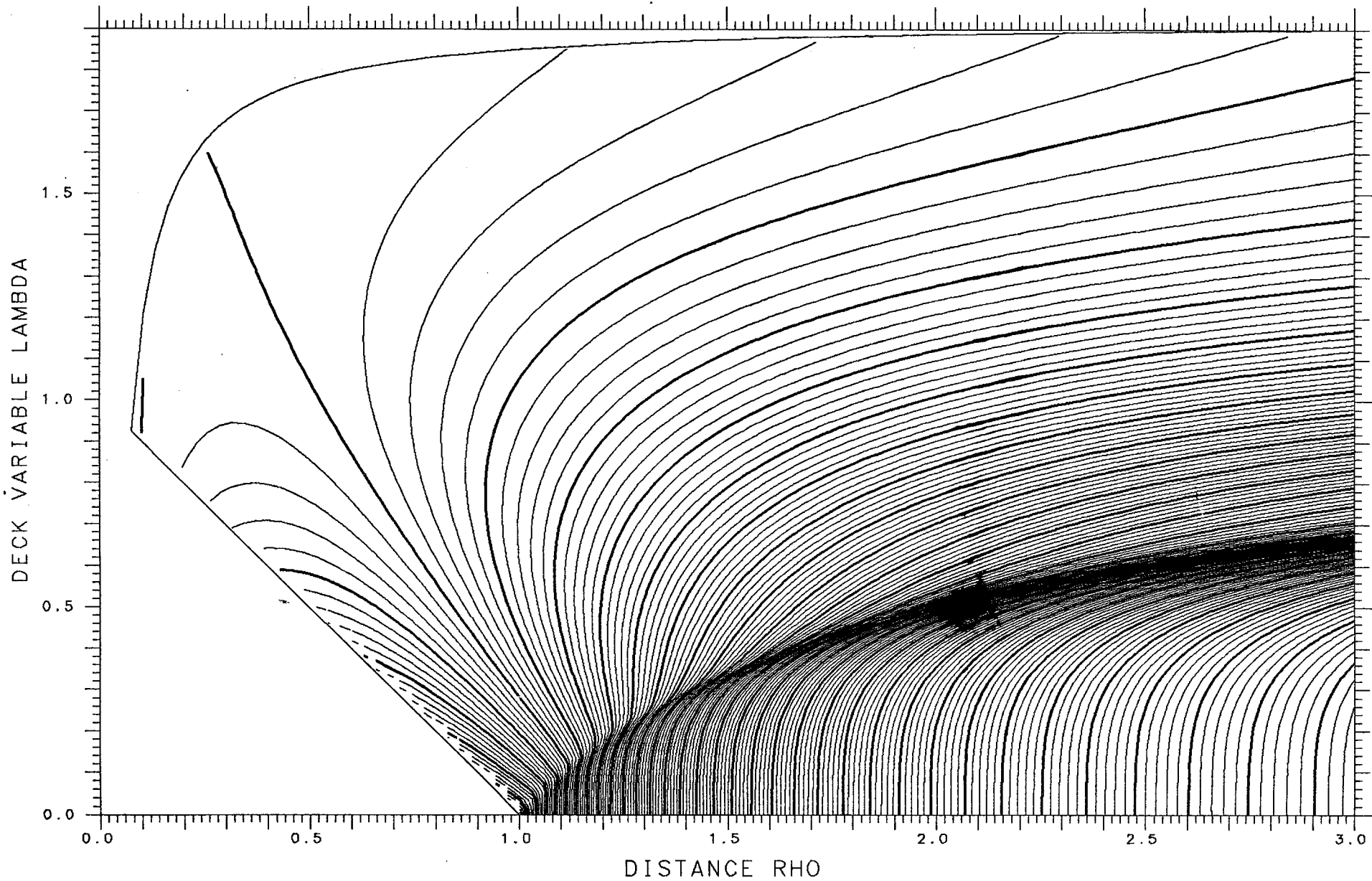

X= .350

ASYMMETRY DELTA= .025

FRACTIONAL= .5374

SPHERES .00148

TANGENT .18430

LENGTH 8.721

ENERGY 351.36

SPACING .005

SADDLE .15125

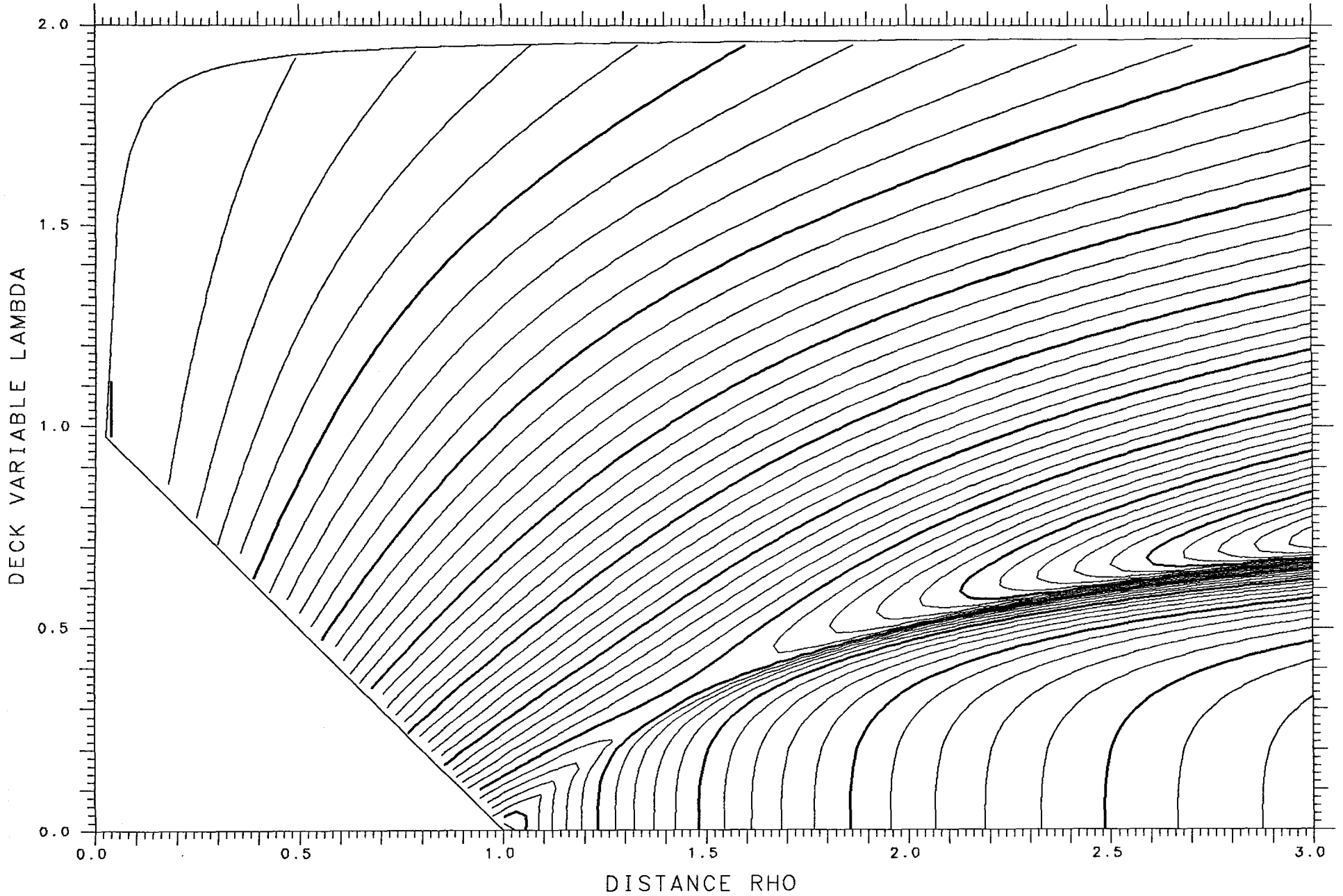

X=1.000 ASYMMETRY DELTA= .050 FRACTIONAL= .5745

SPHERES -.46773 TANGENT .04586 LENGTH 13.259 ENERGY 747.97 SPACING .002

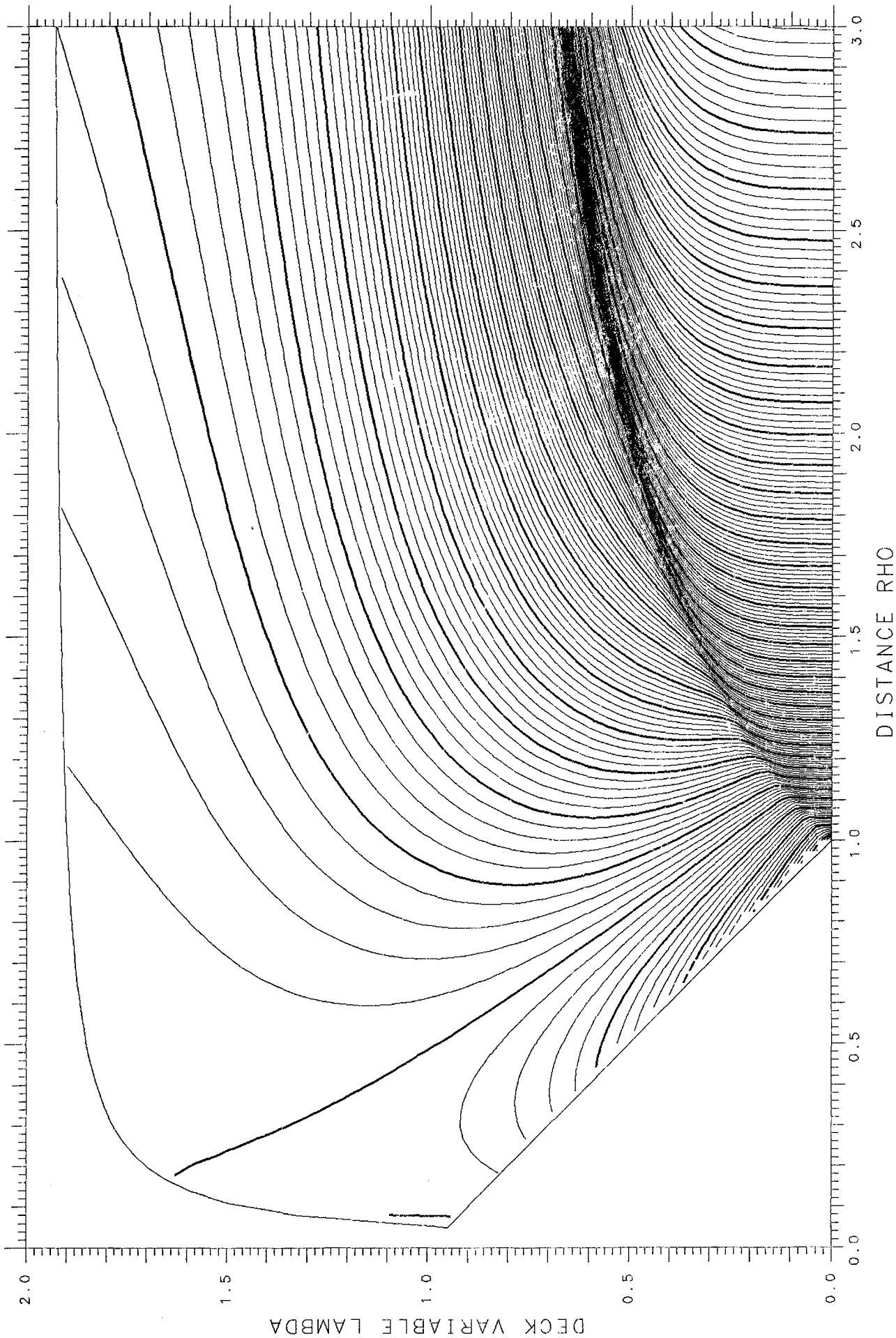

X= .350 ASYMMETRY DELTA= .050 FRACTIONAL= .5745

SPHERES .00321 TANGENT .18332 LENGTH 8.704 ENERGY 351.36 SPACING .005 SADDLE .15094

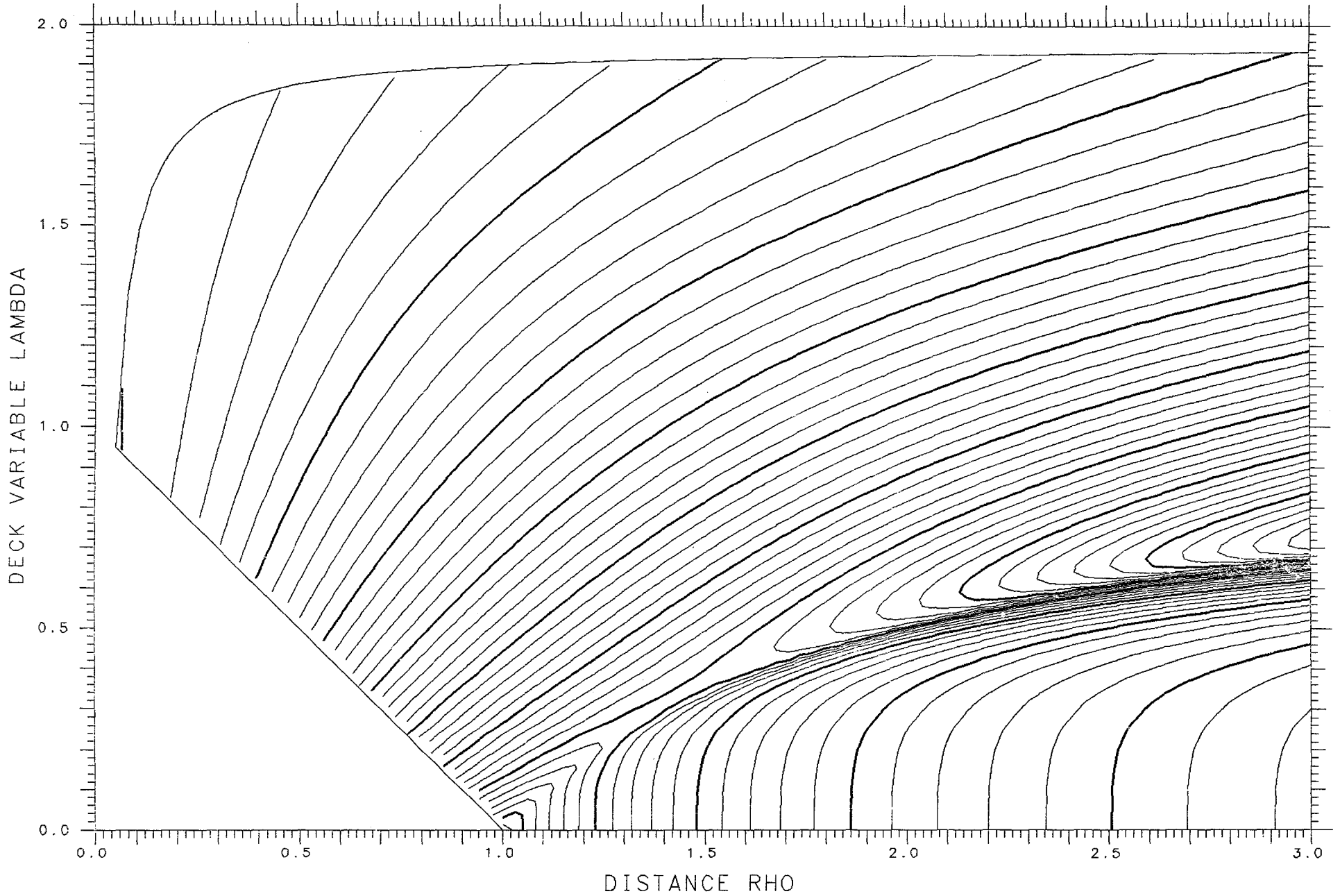

X=1.000

ASYMMETRY DELTA= .025

FRACTIONAL= .5374

SPHERES -.47702

TANGENT .04533

LENGTH 13.283

ENERGY 747.97

SPACING .002

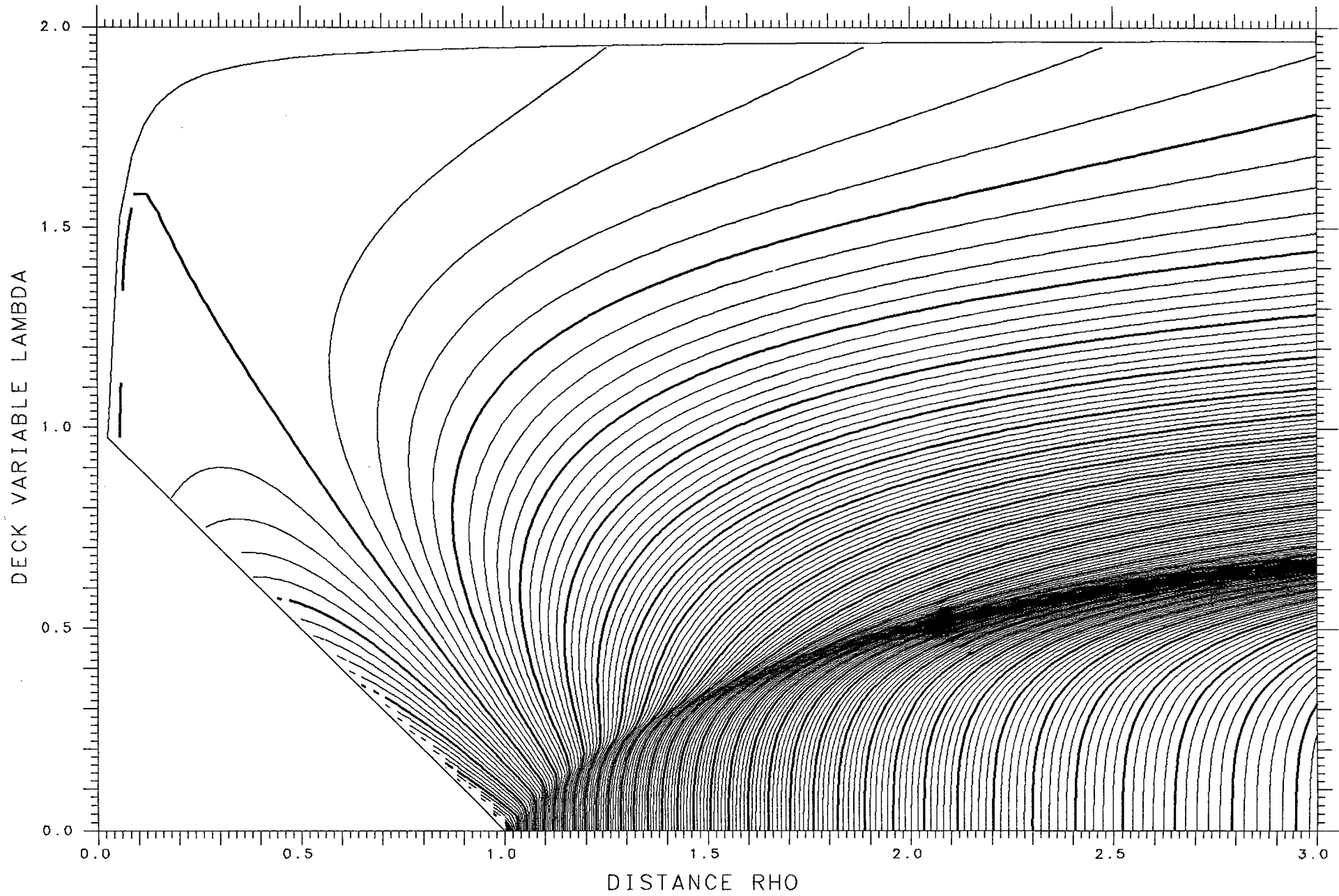

X= .350

ASYMMETRY DELTA= .075

FRACTIONAL= .6108

SPHERES .00599

TANGENT .18167

LENGTH 8.678

ENERGY 351.36

SPACING .005

SADDLE .15038

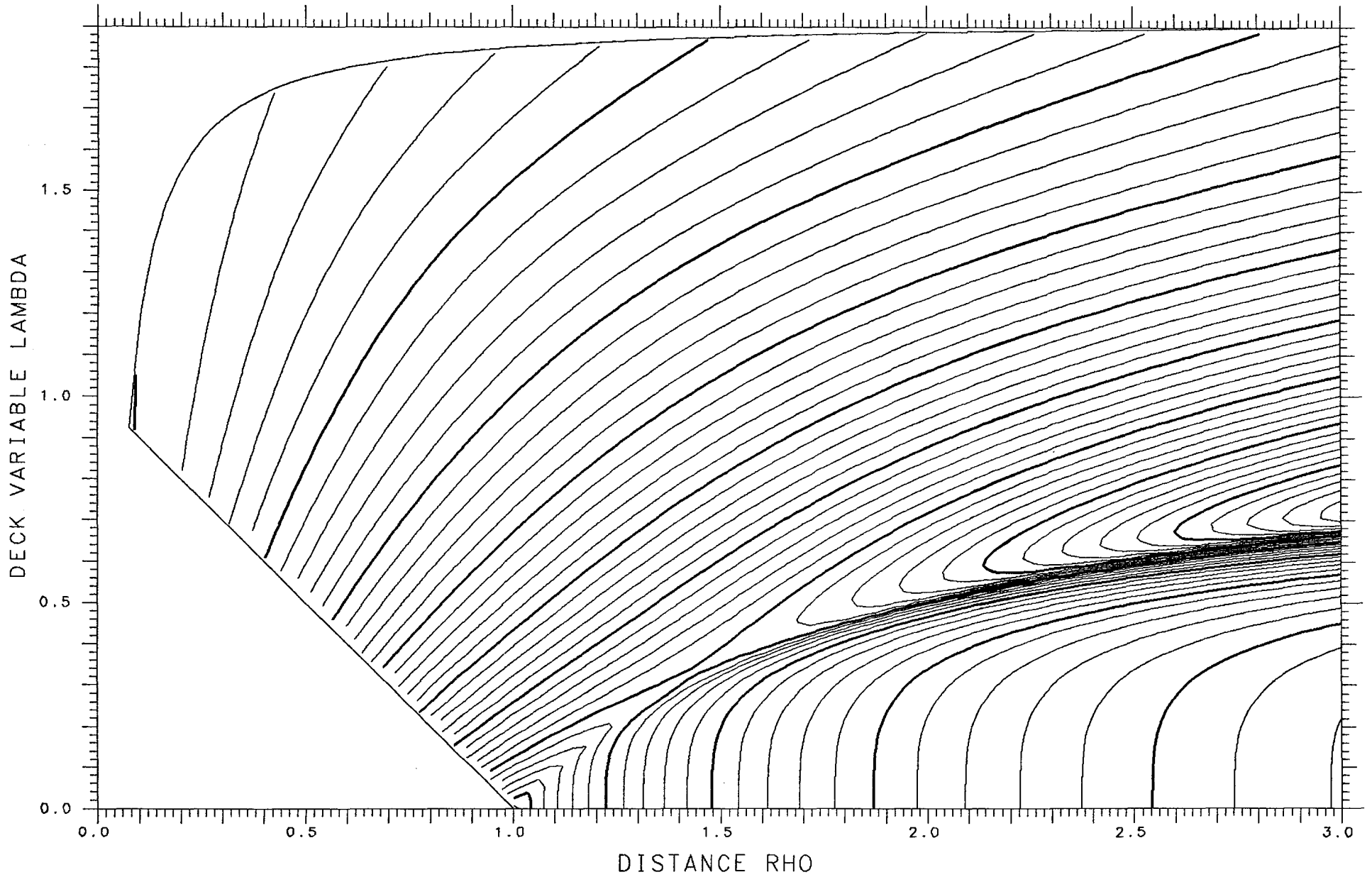

X=1.000

ASYMMETRY DELTA=0.

FRACTIONAL= .5000

SPHERES -.48016

TANGENT .04481

LENGTH 13.292

ENERGY 747.97

SPACING .002

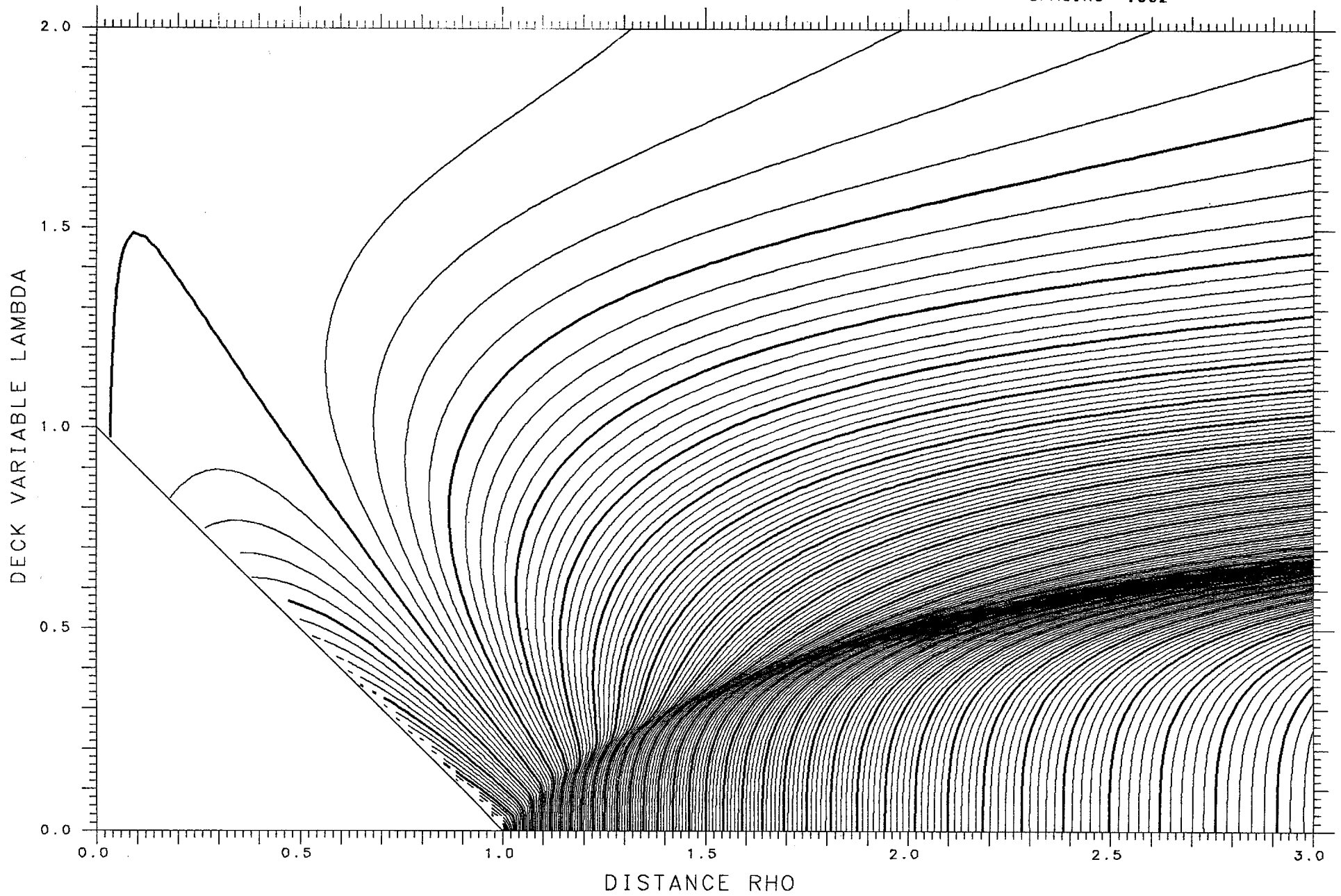

X= .350 ASYMMETRY DELTA= .100 FRACTIONAL= .6461

SPHERES .00965 TANGENT .17936 LENGTH 8.641 ENERGY 351.36 SPACING .005 SADDLE .14953

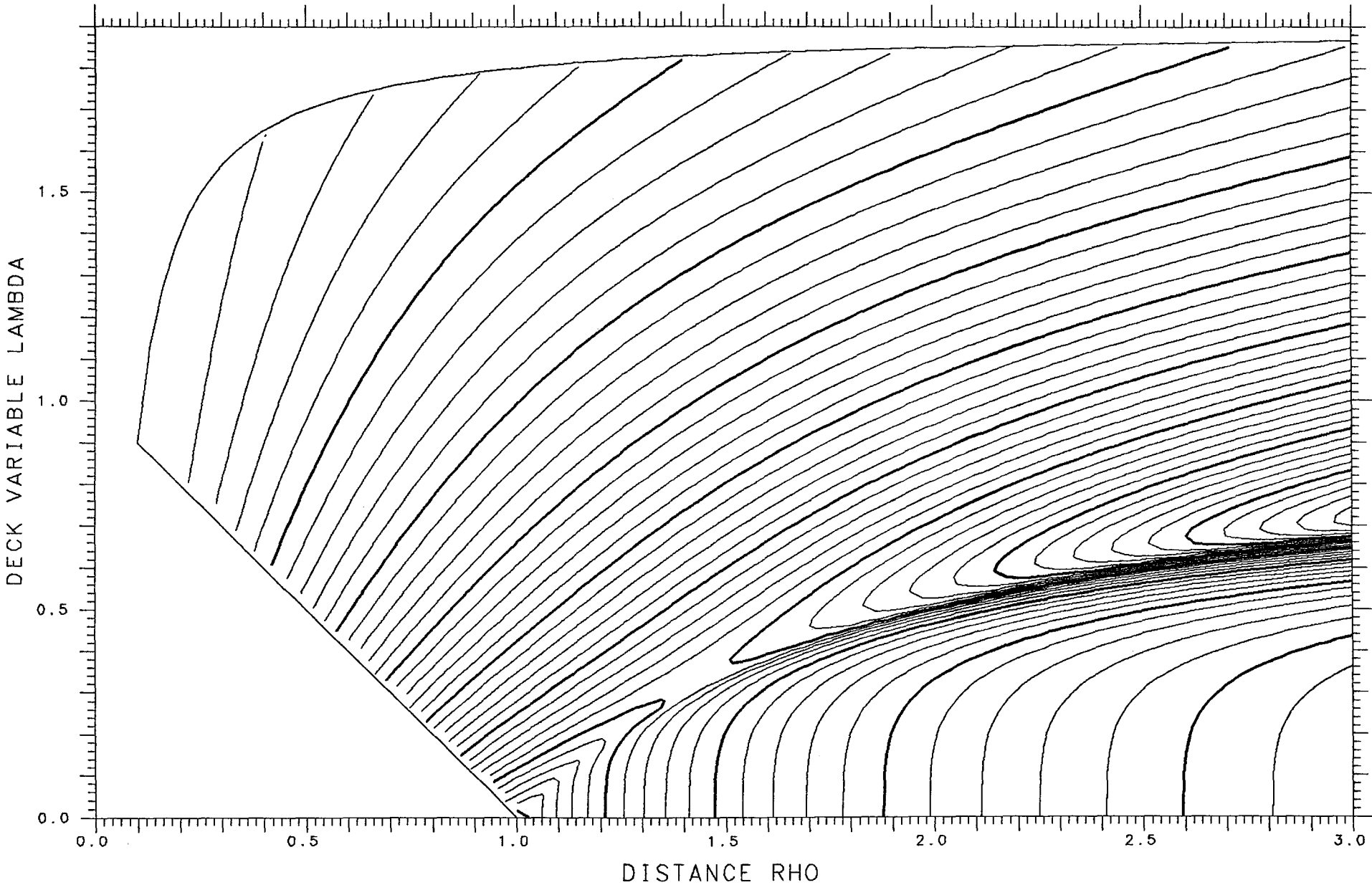

X= .975 ASYMMETRY DELTA= .425 FRACTIONAL= .9384

SPHERES -.06293 TANGENT .07390 LENGTH 11.390 ENERGY 735.16 SPACING .002

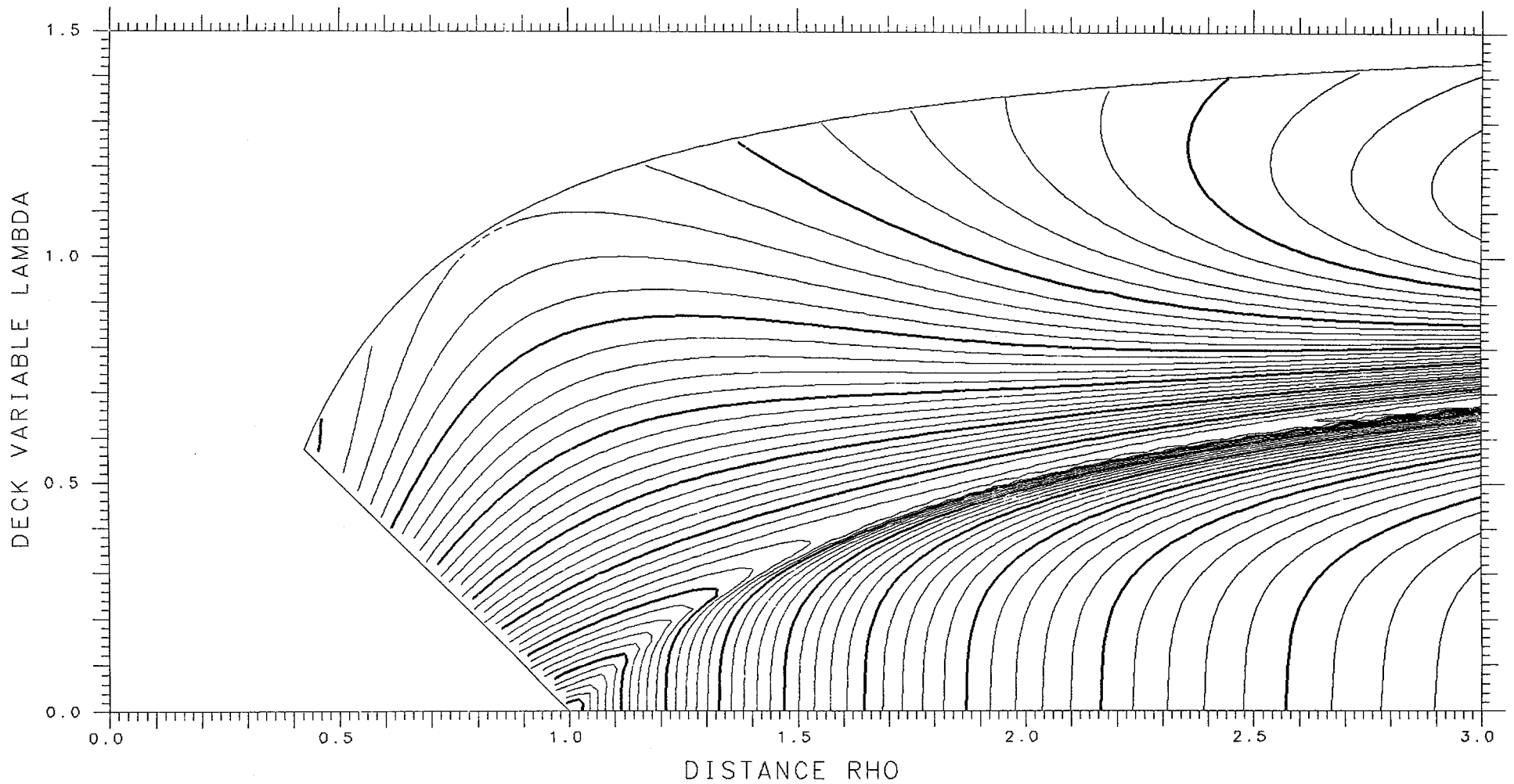

X= .350 ASYMMETRY DELTA= .125 FRACTIONAL= .6800

SPHERES .01401 TANGENT .17639 LENGTH 8.594 ENERGY 351.36 SPACING .005 SADDLE .14633

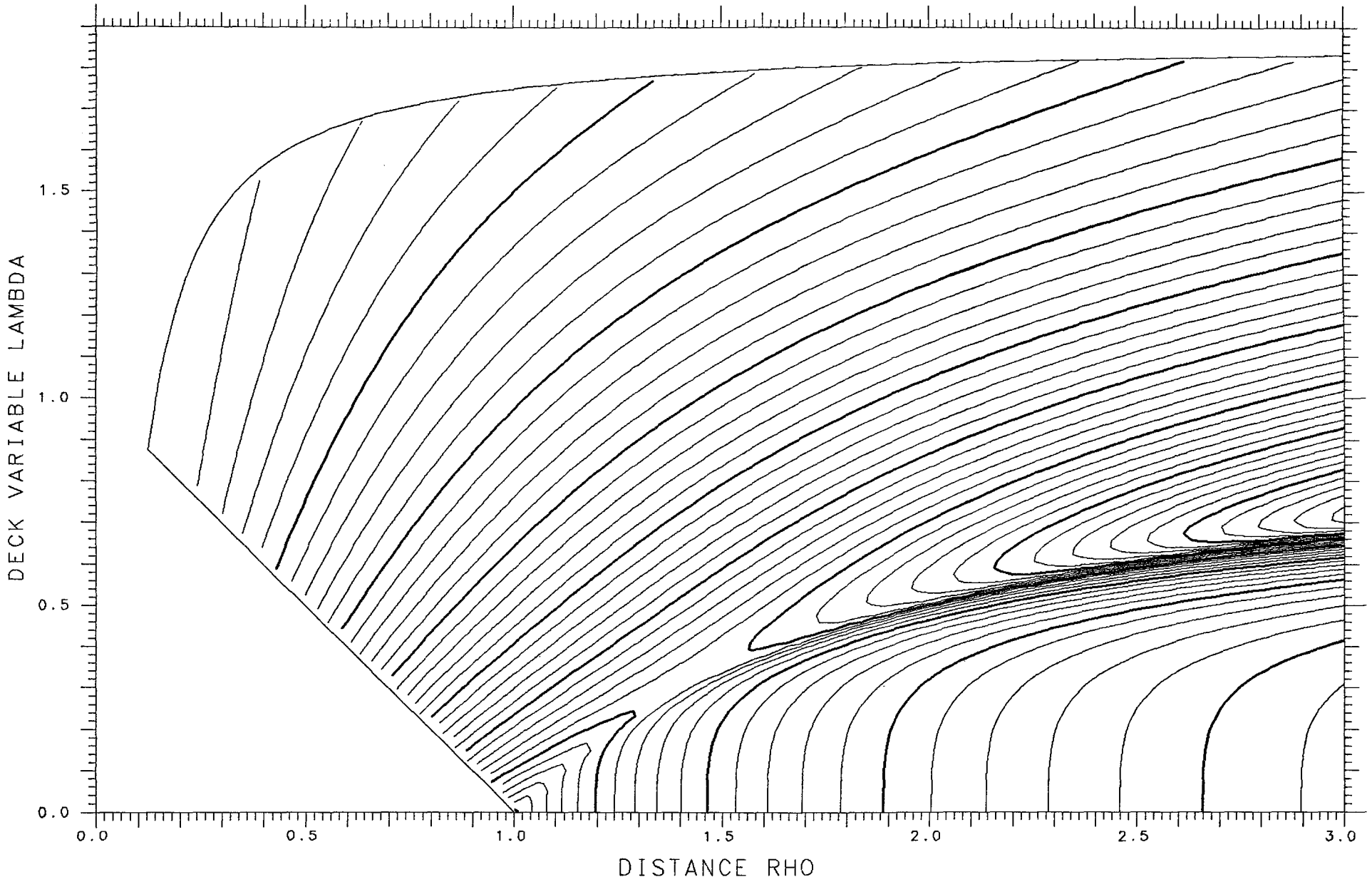

X = .975 ASYMMETRY DELTA = .400 FRACTIONAL = .9270
SPHERES = -.08113 TANGENT .07670 LENGTH 11.517 ENERGY 735.16 SPACING .002

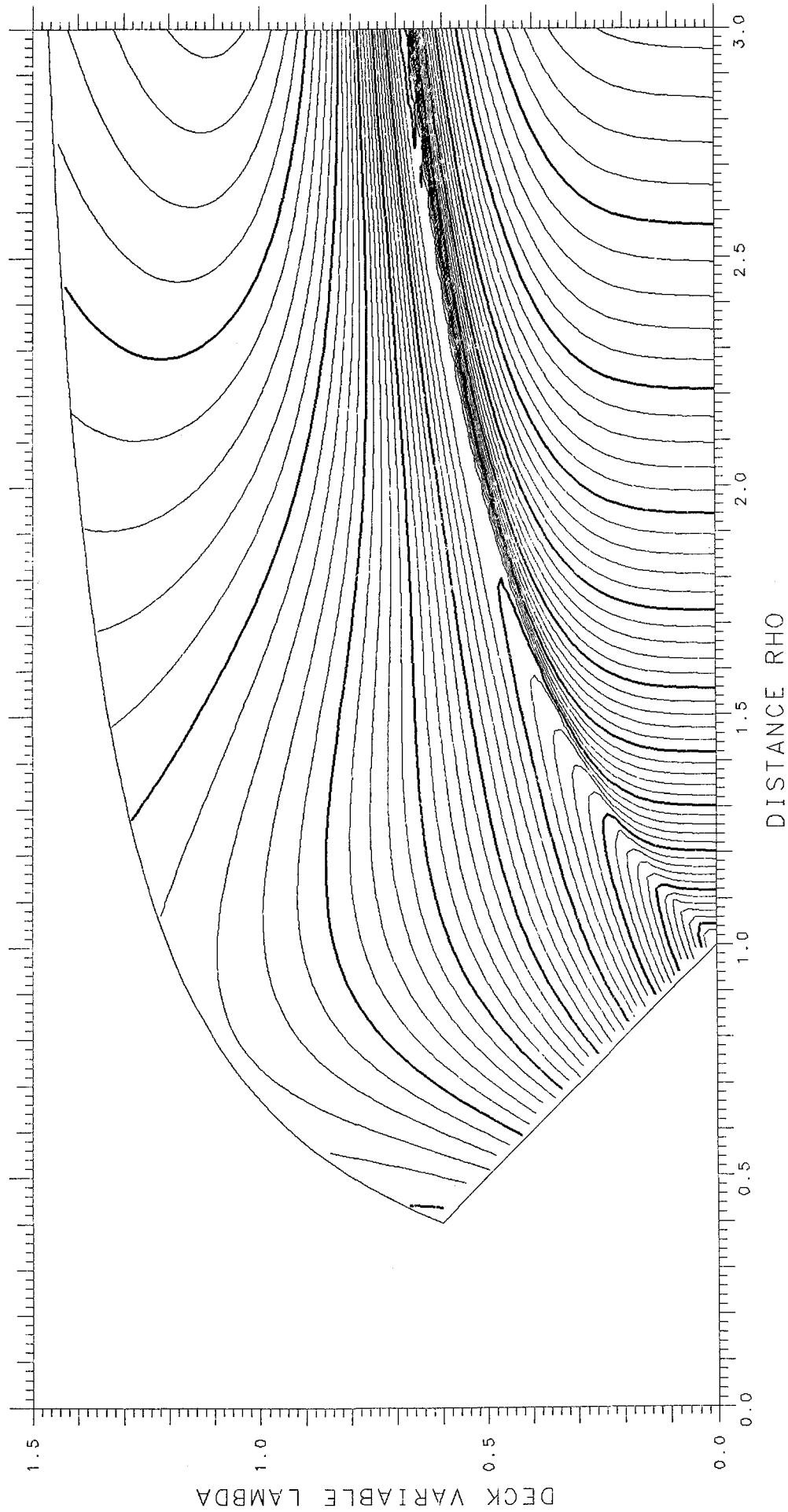

X= .350 ASYMMETRY DELTA= .150 FRACTIONAL= .7124

SPHERES .01885 TANGENT .17276 LENGTH 8.538 ENERGY 351.36 SPACING .005 SADDLE .14673

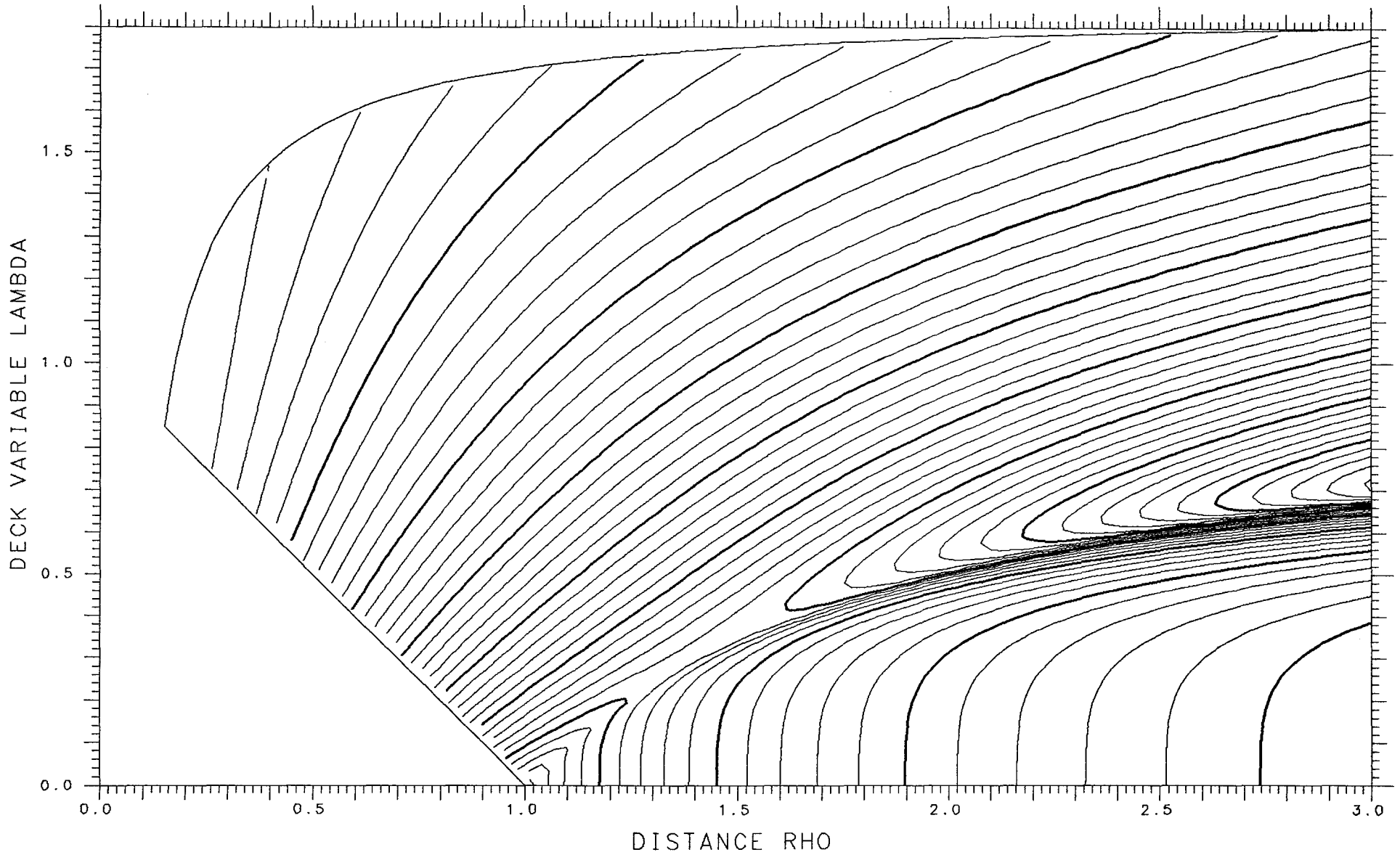

X= .975 ASYMMETRY DELTA= .375 FRACTIONAL= .9141

SPHERES -.10185 TANGENT .07883 LENGTH 11.702 ENERGY 735.16 SPACING .002

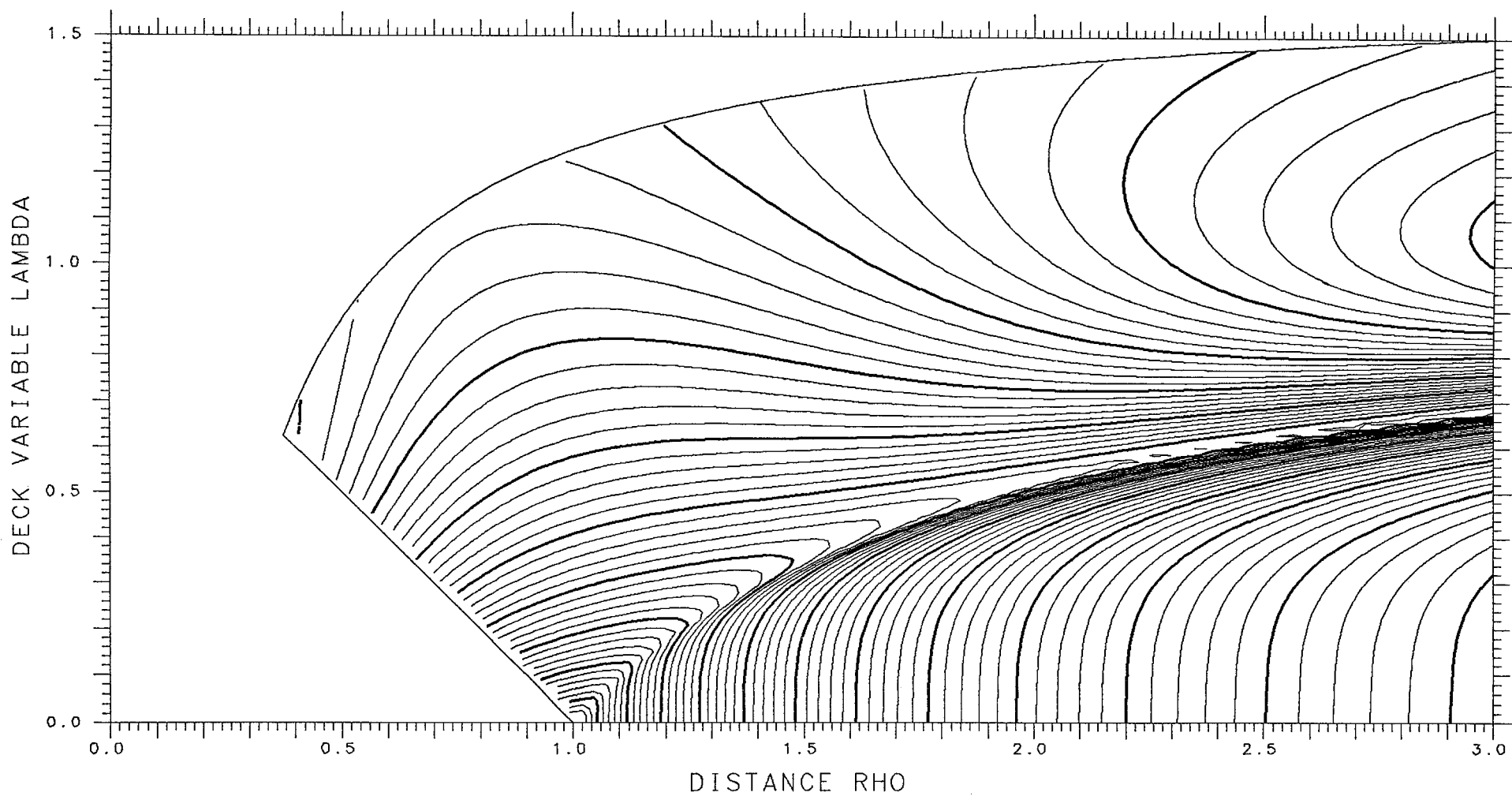

X= .350 ASYMMETRY DELTA= .175 FRACTIONAL= .7429

SPHERES .02392 TANGENT .16848 LENGTH 8.474 ENERGY 351.36 SPACING .005 SADDLE .14465

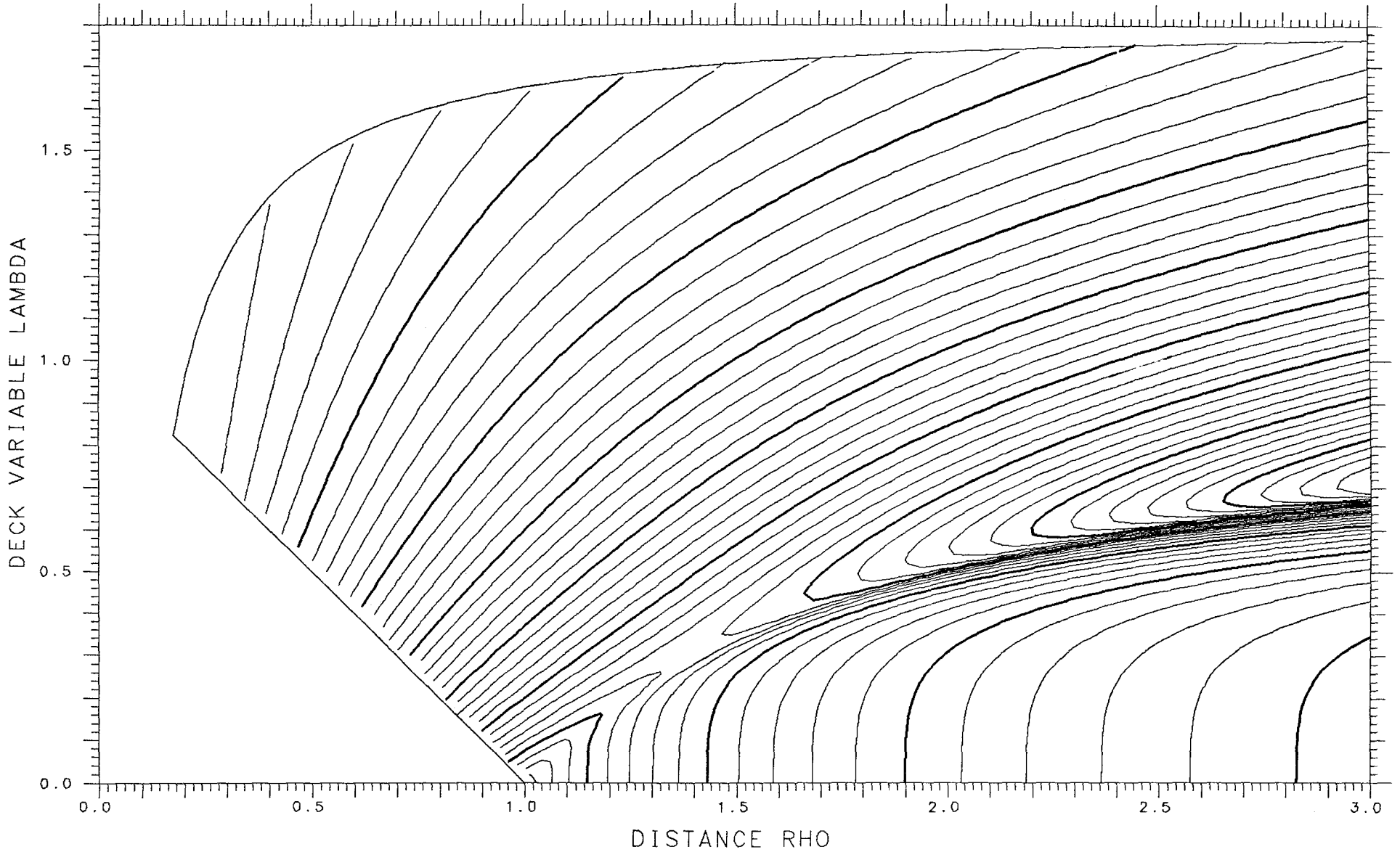

X= .975 ASYMMETRY DELTA= .350 FRACTIONAL= .8996

SPHERES -.12507 TANGENT .08020 LENGTH 11.855 ENERGY 735.16 SPACING .002

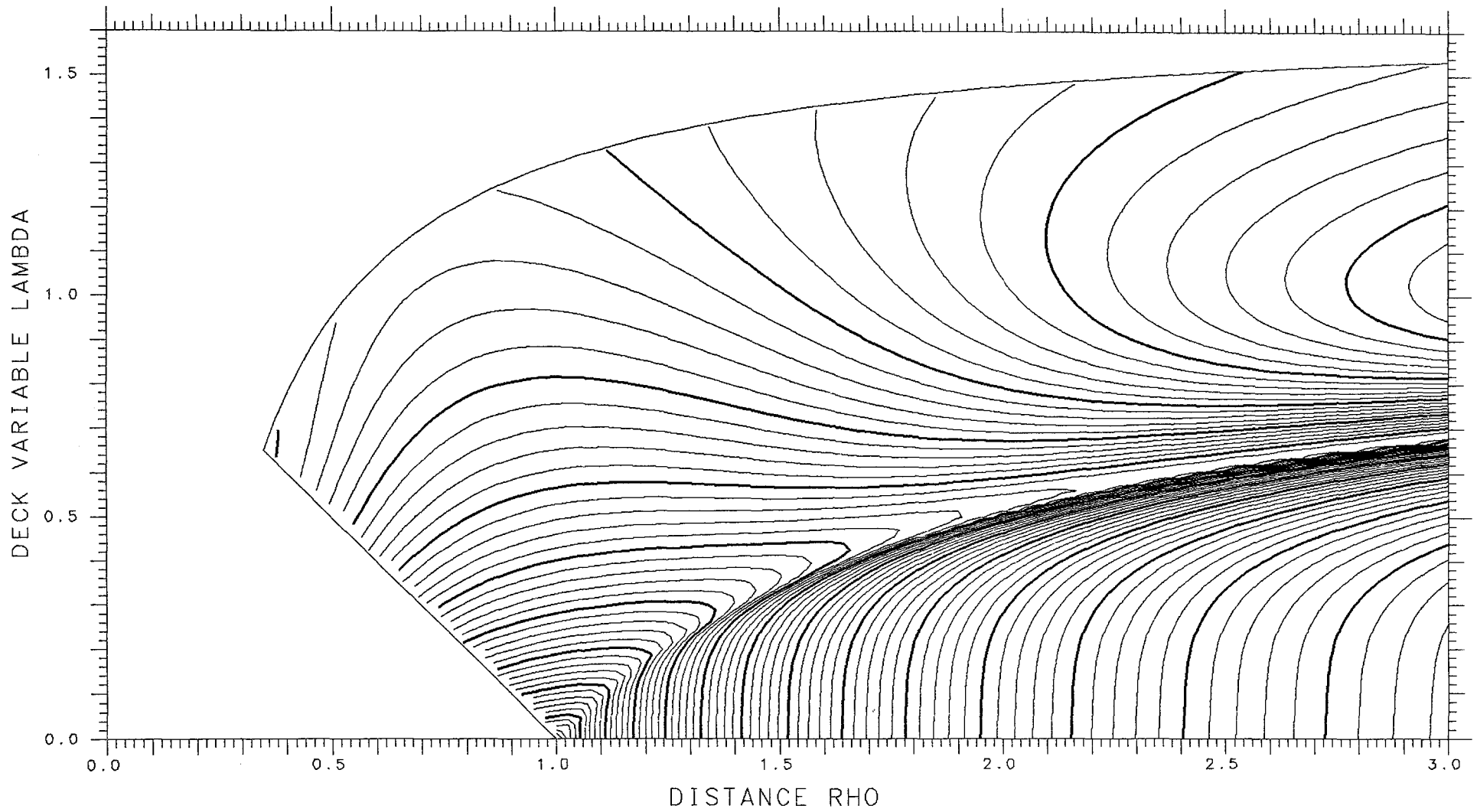

X= .350 ASYMMETRY DELTA= .200 FRACTIONAL= .7714

SPHERES .02899 TANGENT .16357 LENGTH 8.403 ENERGY 351.36 SPACING .005 SADDLE .14206

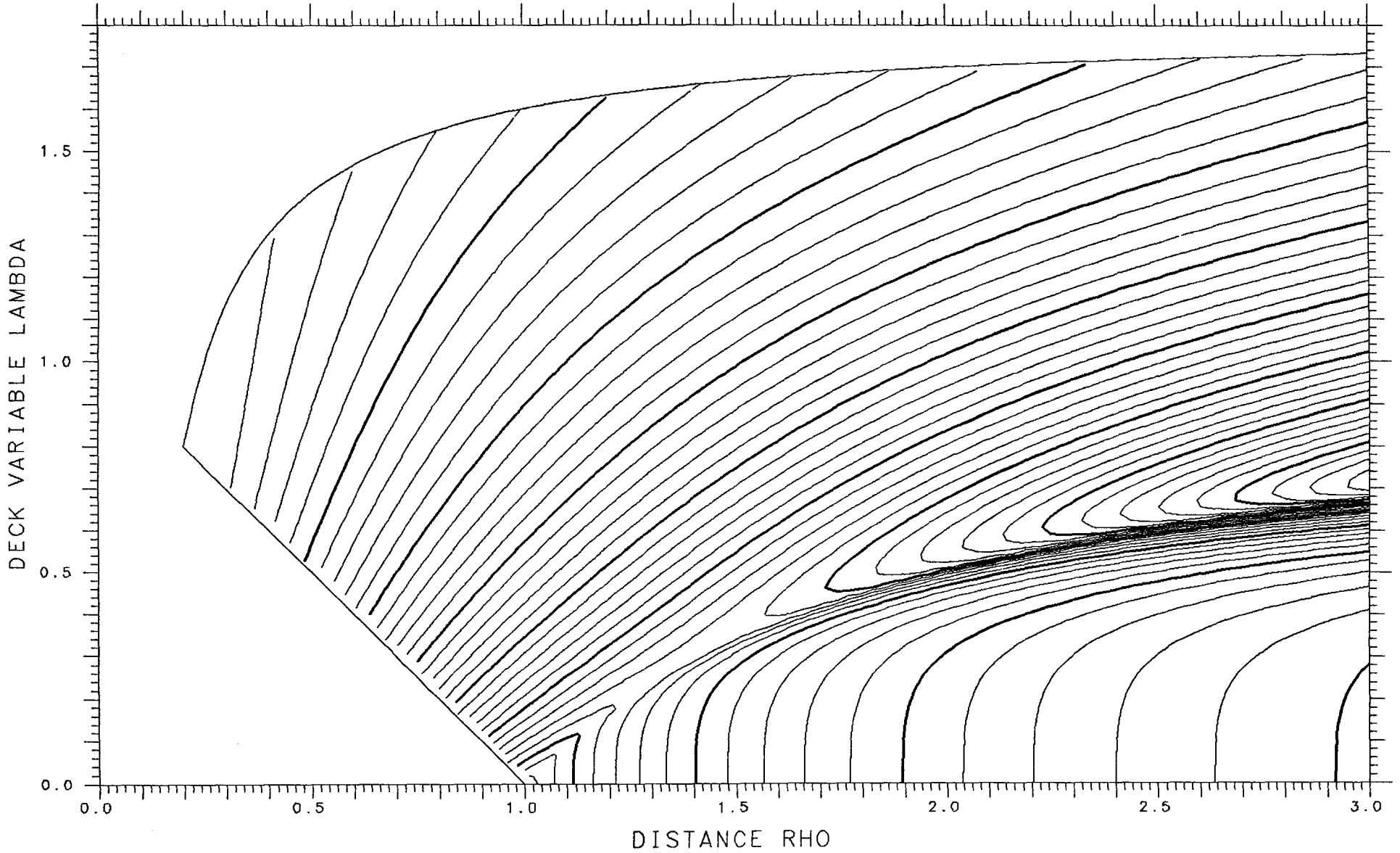

X= .975 ASYMMETRY DELTA= .325 FRACTIONAL= .8832

SPHERES - .15068 TANGENT .08077 LENGTH 12.005 ENERGY 735.16 SPACING .002

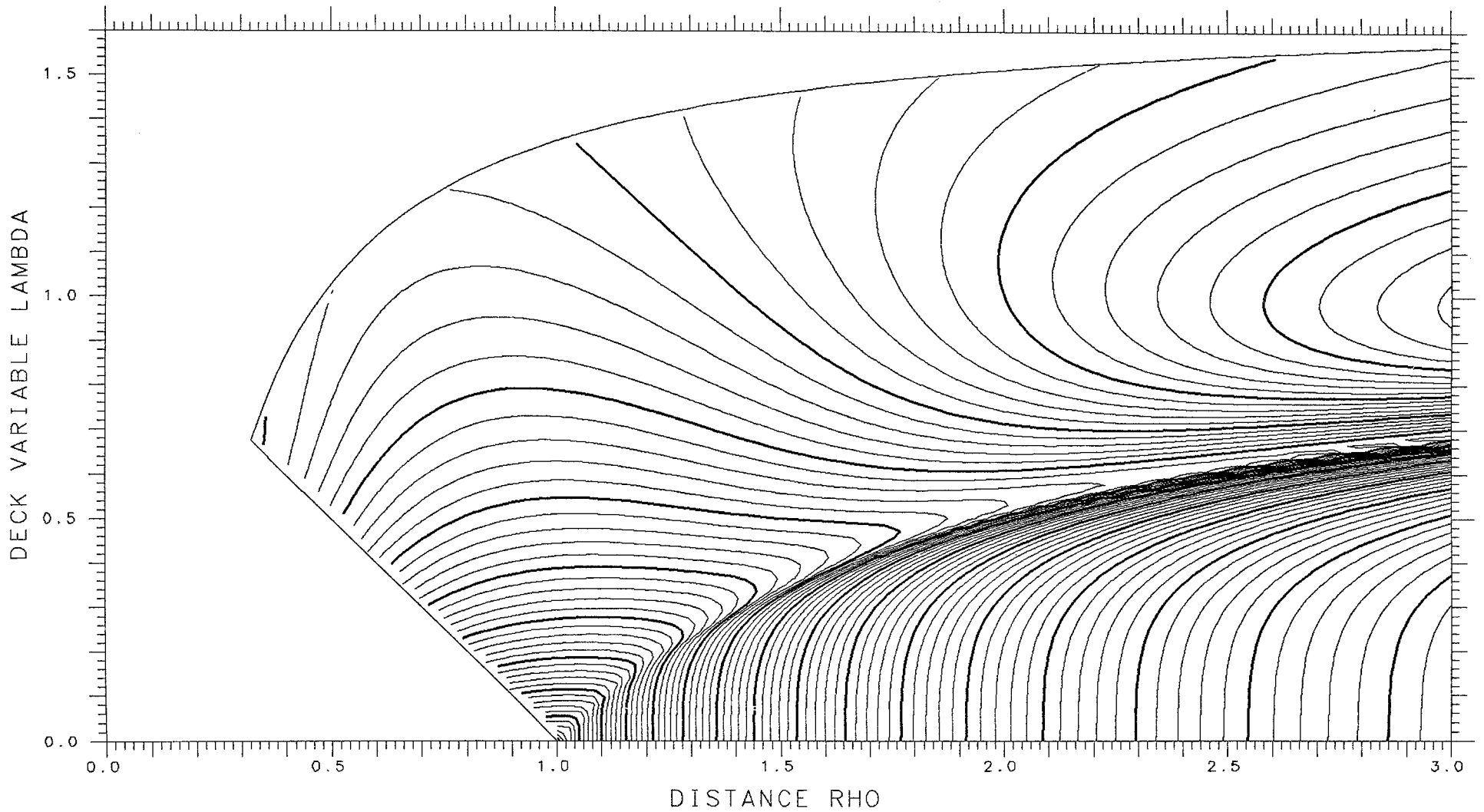

X= .350 ASYMMETRY DELTA= .225 FRACTIONAL= .7979

SPHERES .03386 TANGENT .15808 LENGTH 8.324 ENERGY 351.36 SPACING .005 SADDLE .13891

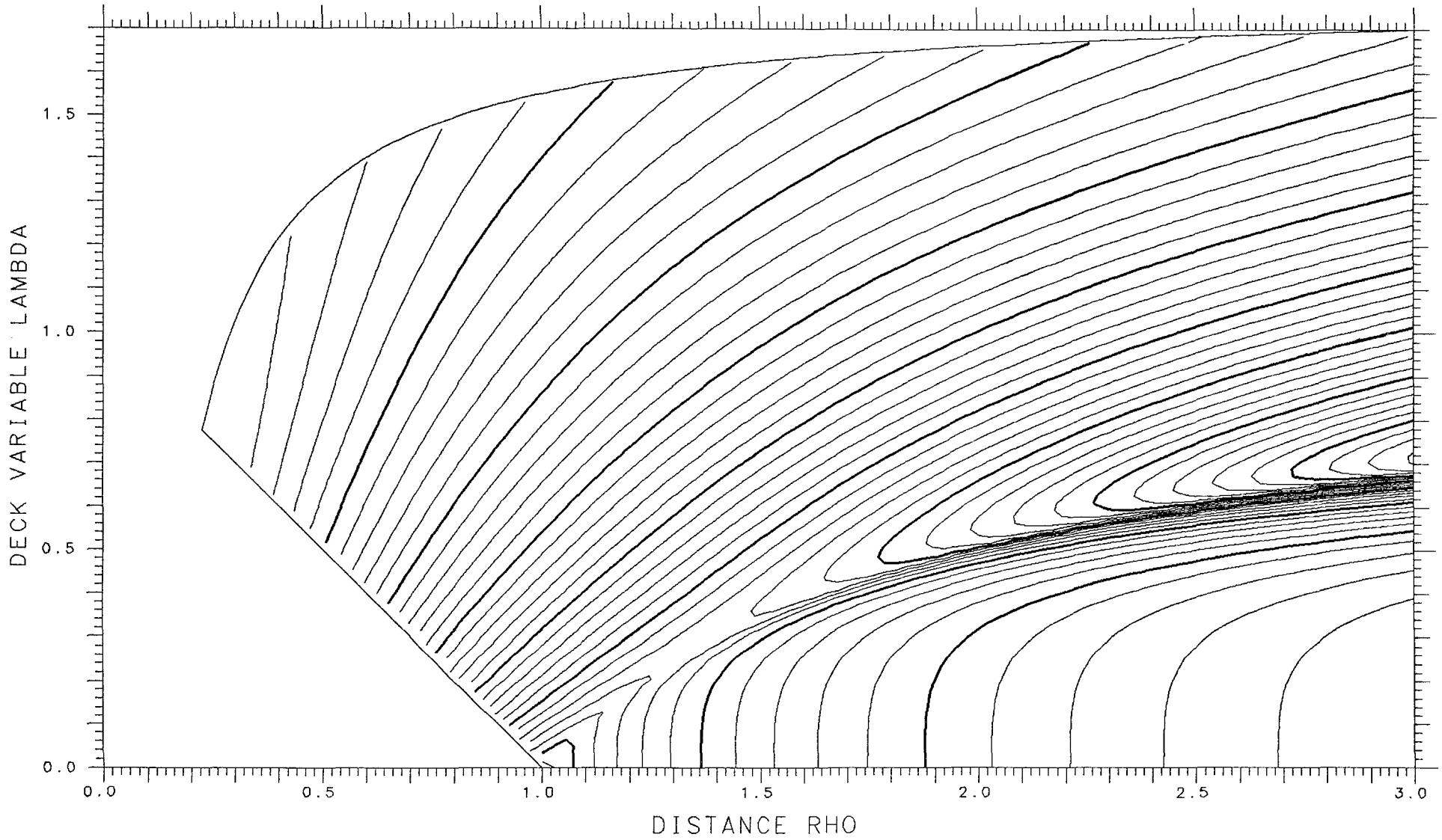

X= .975 ASYMMETRY DELTA= .300 FRACTIONAL= .8650

SPHERES - .17847 TANGENT .08050 LENGTH 12.151 ENERGY 735.16 SPACING .002

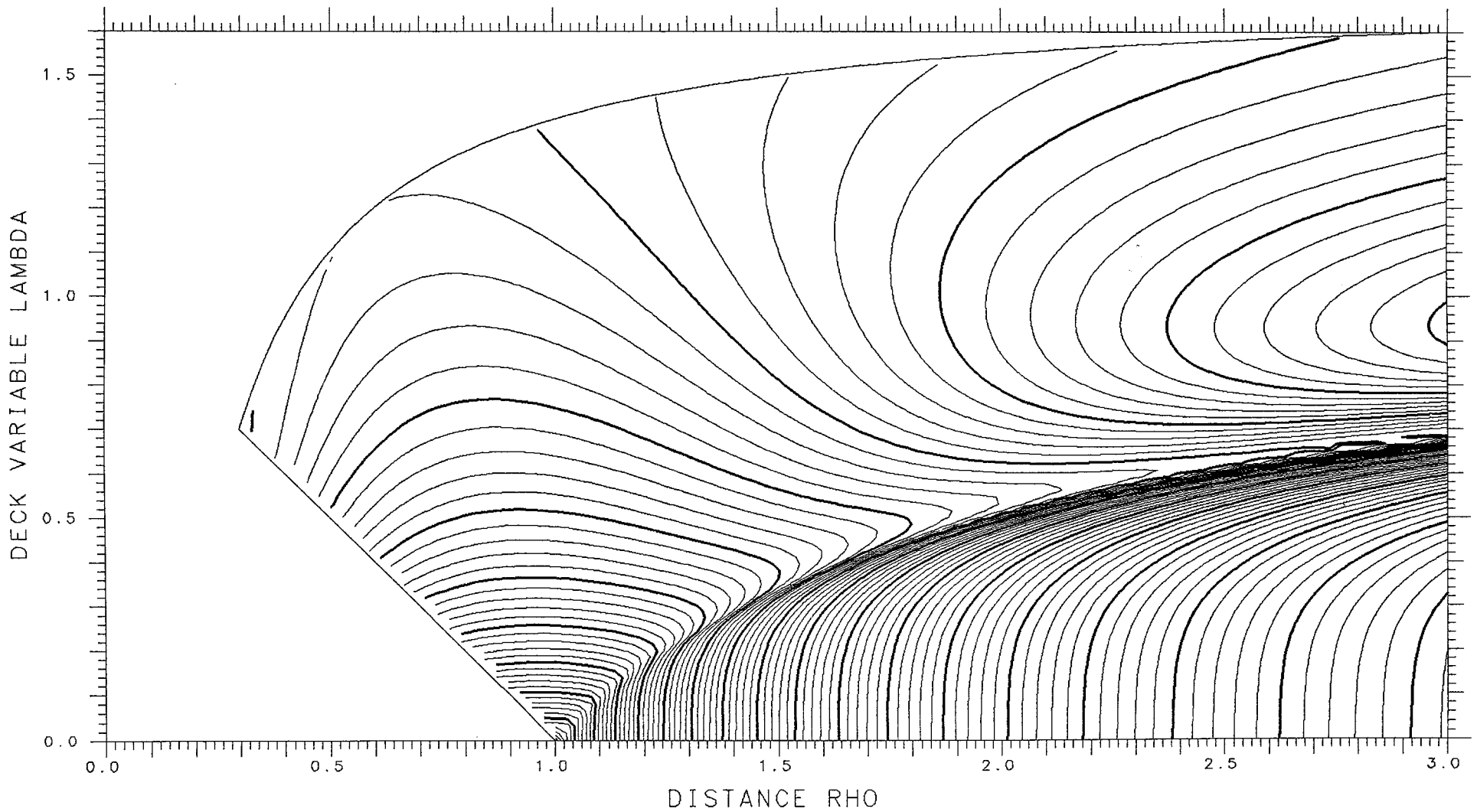

X= .350 ASYMMETRY DELTA= .250 FRACTIONAL= .8224

SPHERES .03834 TANGENT .15203 LENGTH 8.240 ENERGY 351.36 SPACING .005

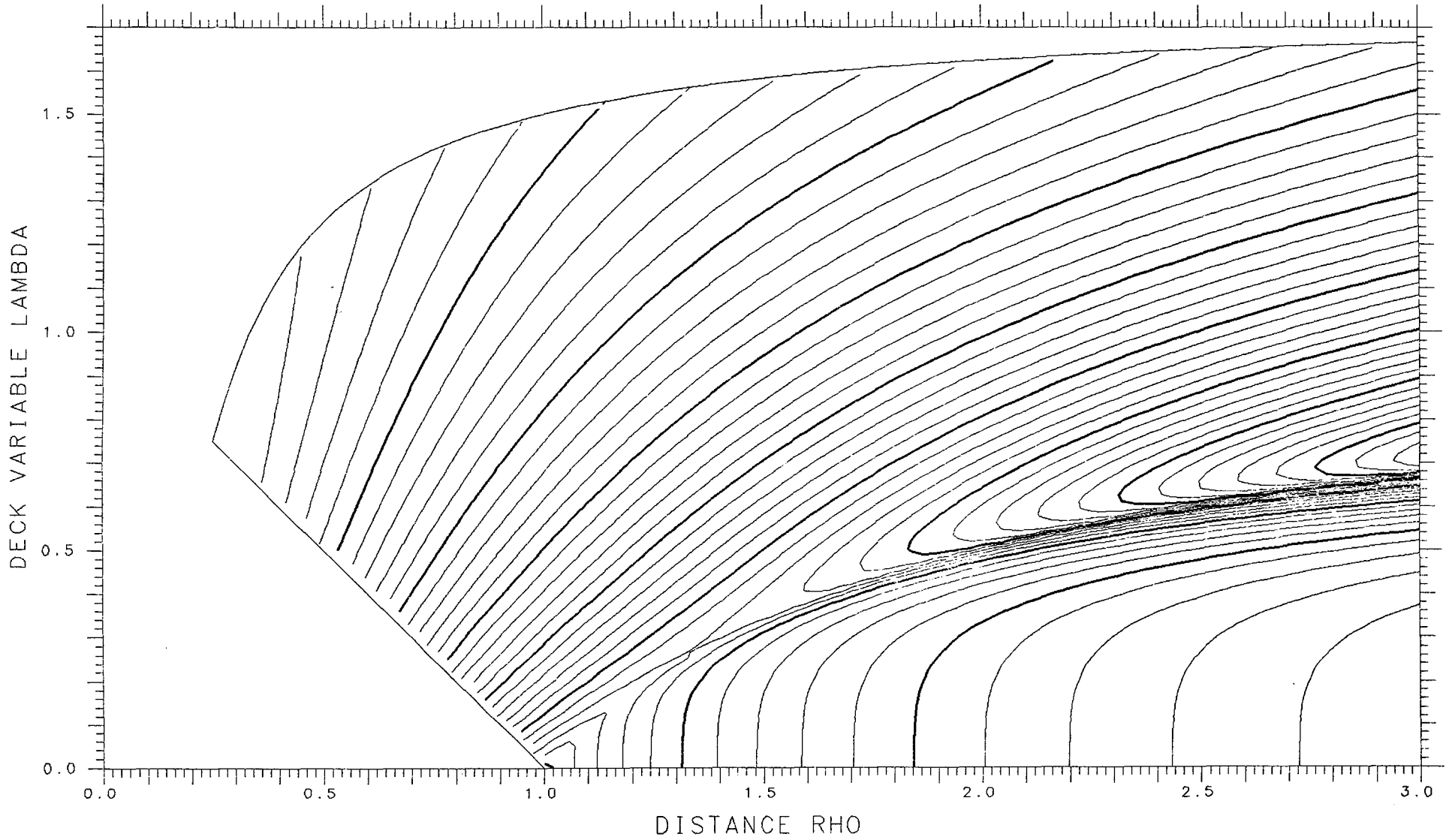

X= .975 ASYMMETRY DELTA= .275 FRACTIONAL= .8447

SPHERES -.20813 TANGENT .07940 LENGTH 12.292 ENERGY 735.16 SPACING .002

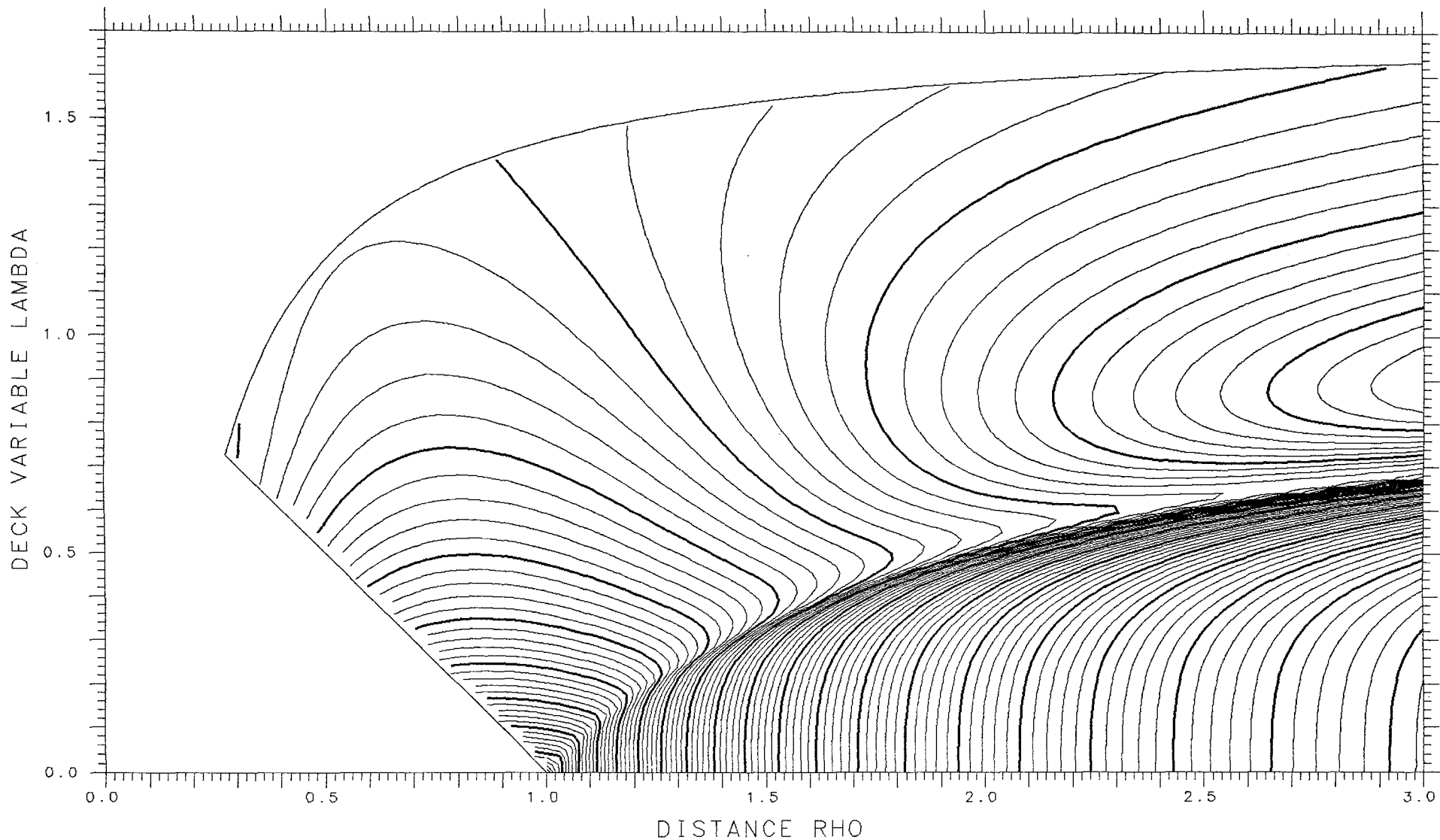

X= .350 ASYMMETRY DELTA= .275 FRACTIONAL= .8447

SPHERES .04228 TANGENT .14550 LENGTH 8.151 ENERGY 351.36 SPACING .005

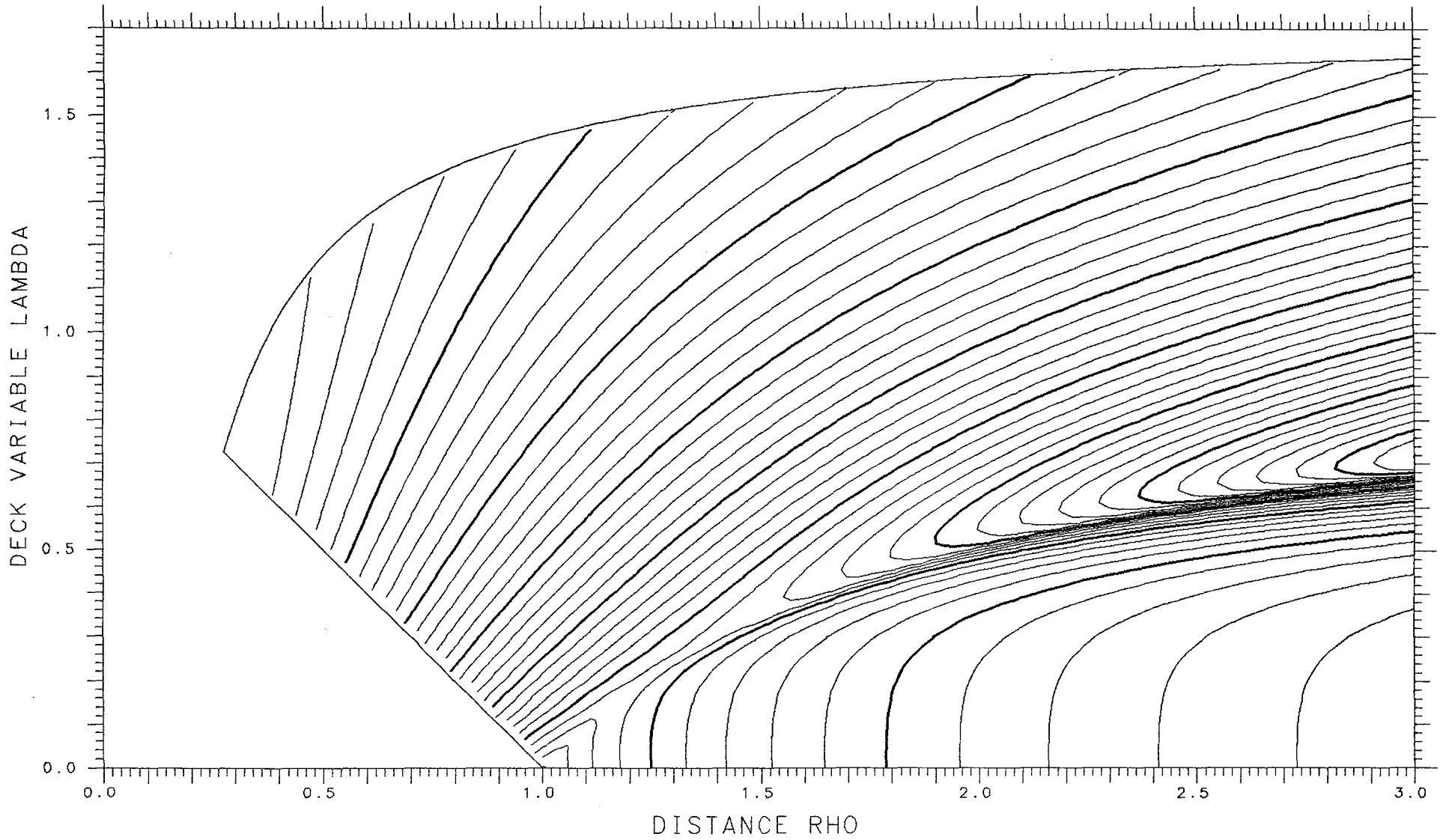

X= .975 ASYMMETRY DELTA= .250 FRACTIONAL= .8224

SPHERES -.23919 TANGENT .07752 LENGTH **12.426** ENERGY **735.16** SPACING .002

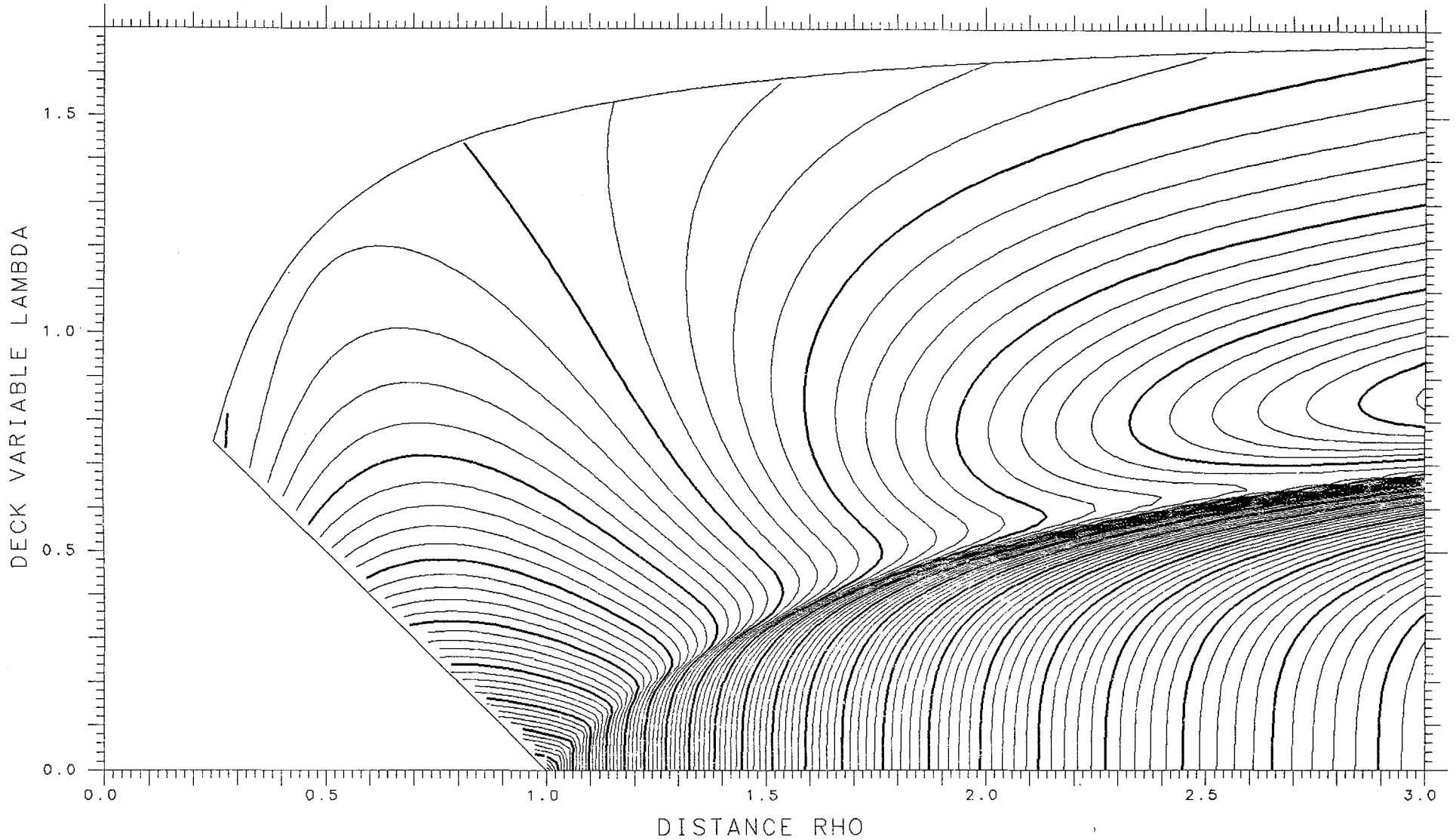

X= .350 ASYMMETRY DELTA= .300 FRACTIONAL= .8650

SPHERES .04557 TANGENT .13853 LENGTH 8.058 ENERGY 351.36 SPACING .005

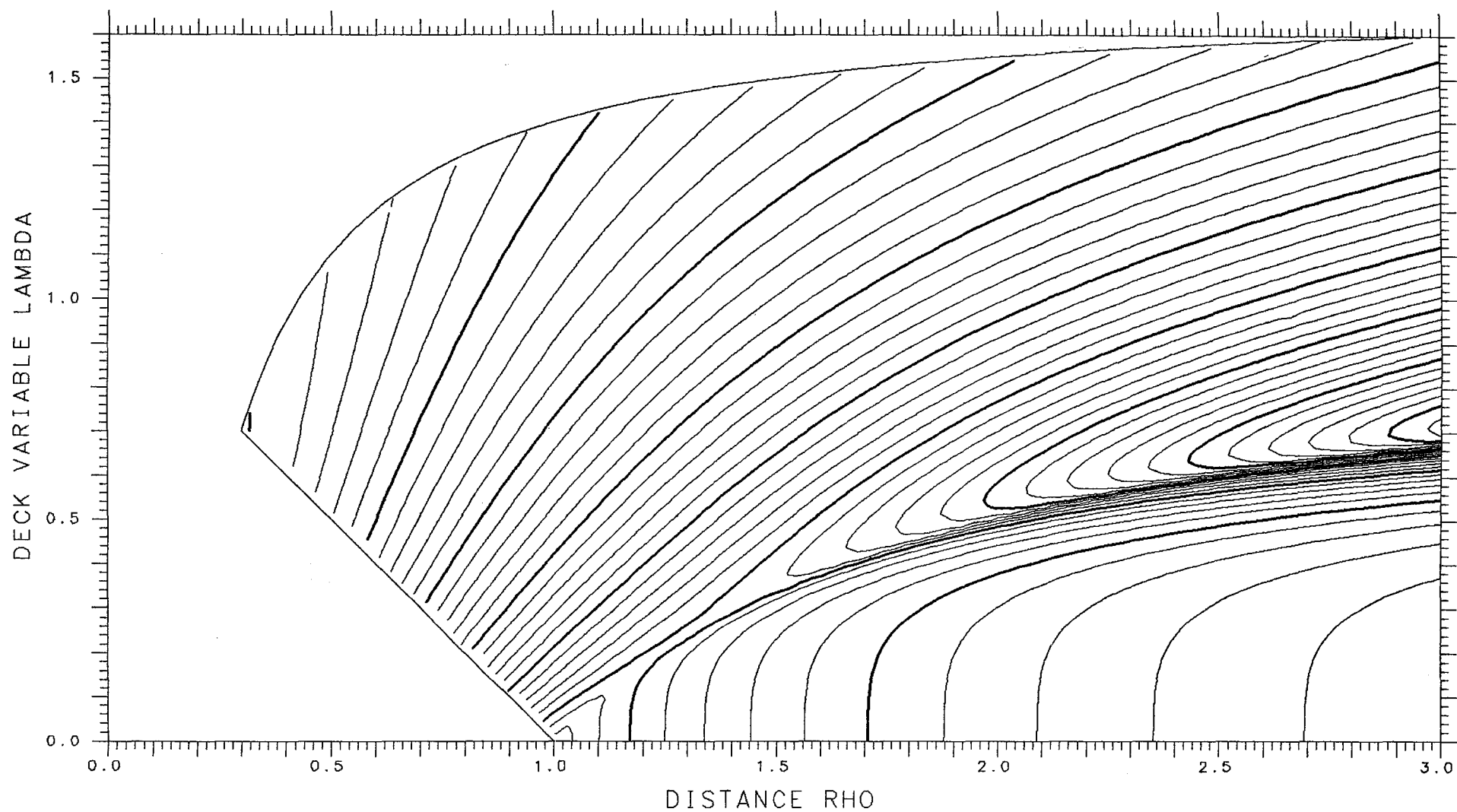

X= .975 ASYMMETRY DELTA= .225 FRACTIONAL= .7979

SPHERES -.27108 TANGENT .07494 LENGTH 12.553 ENERGY 735.16 SPACING .002

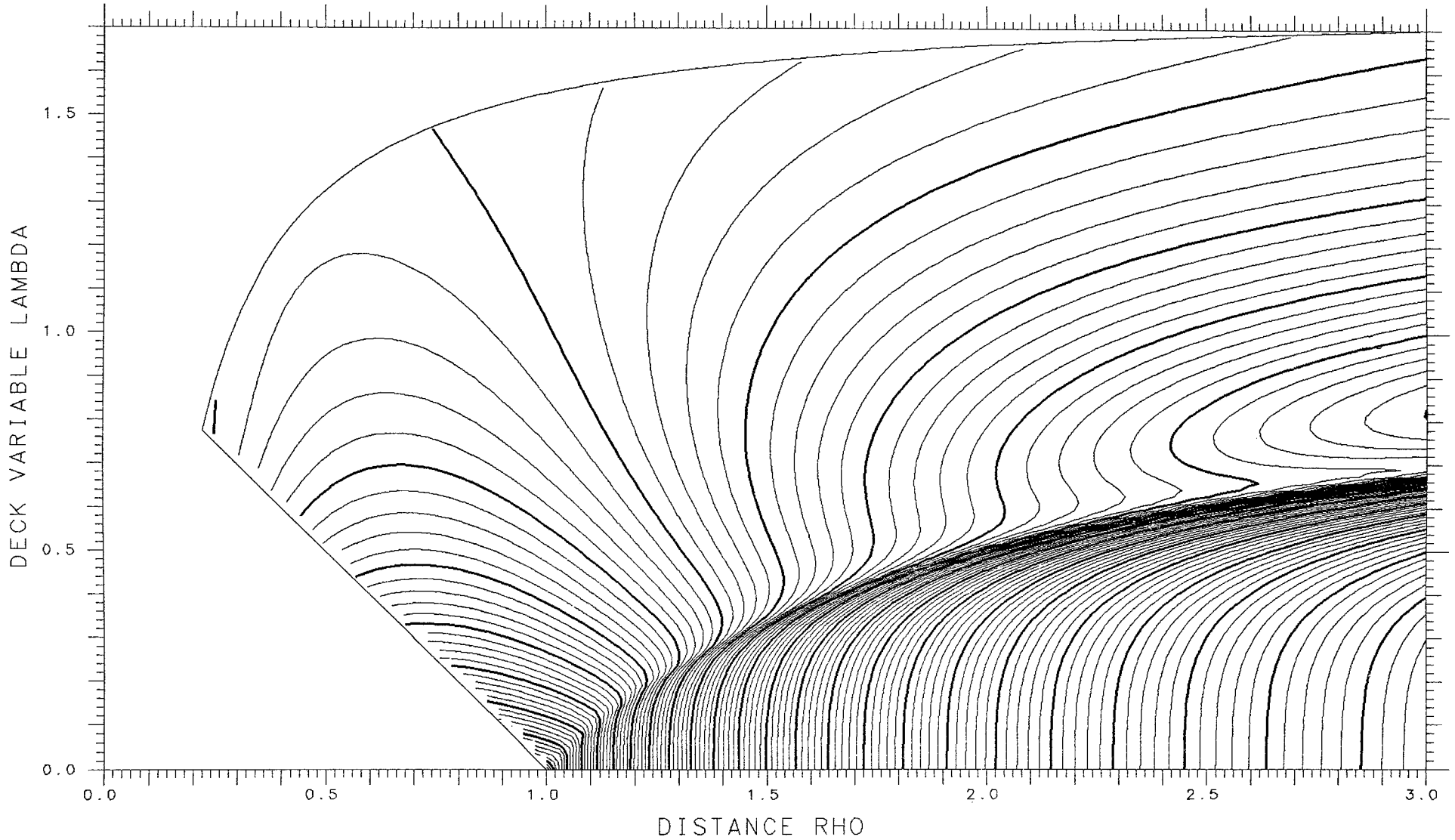

X= .350 ASYMMETRY DELTA= .325 FRACTIONAL= .8832

SPHERES .04813 TANGENT .13121 LENGTH 7.961 ENERGY 351.36 SPACING .005

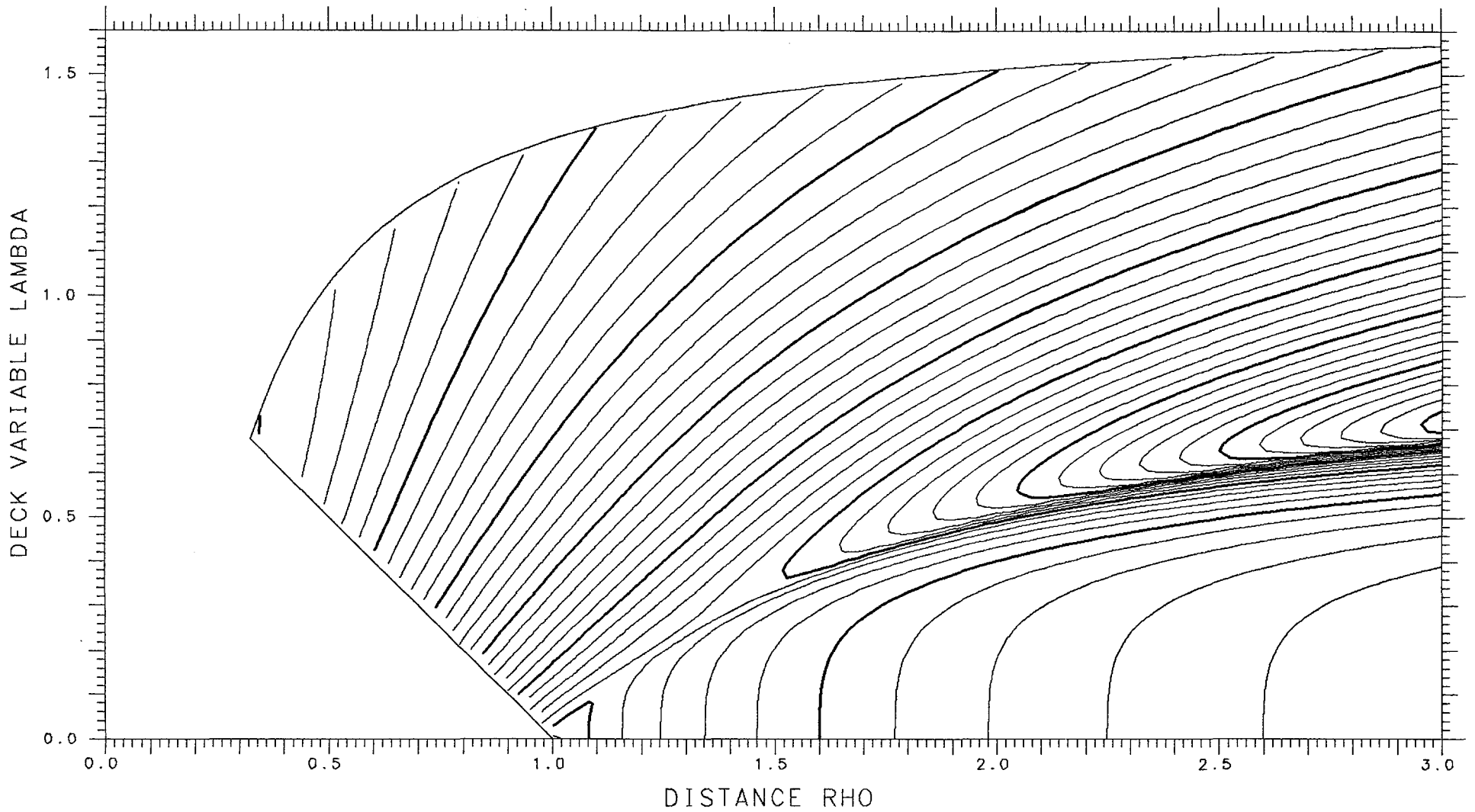

X= .975 ASYMMETRY DELTA= .200 FRACTIONAL= .7714

SPHERES -.30311 TANGENT .07180 LENGTH 12.671 ENERGY 735.16 SPACING .002

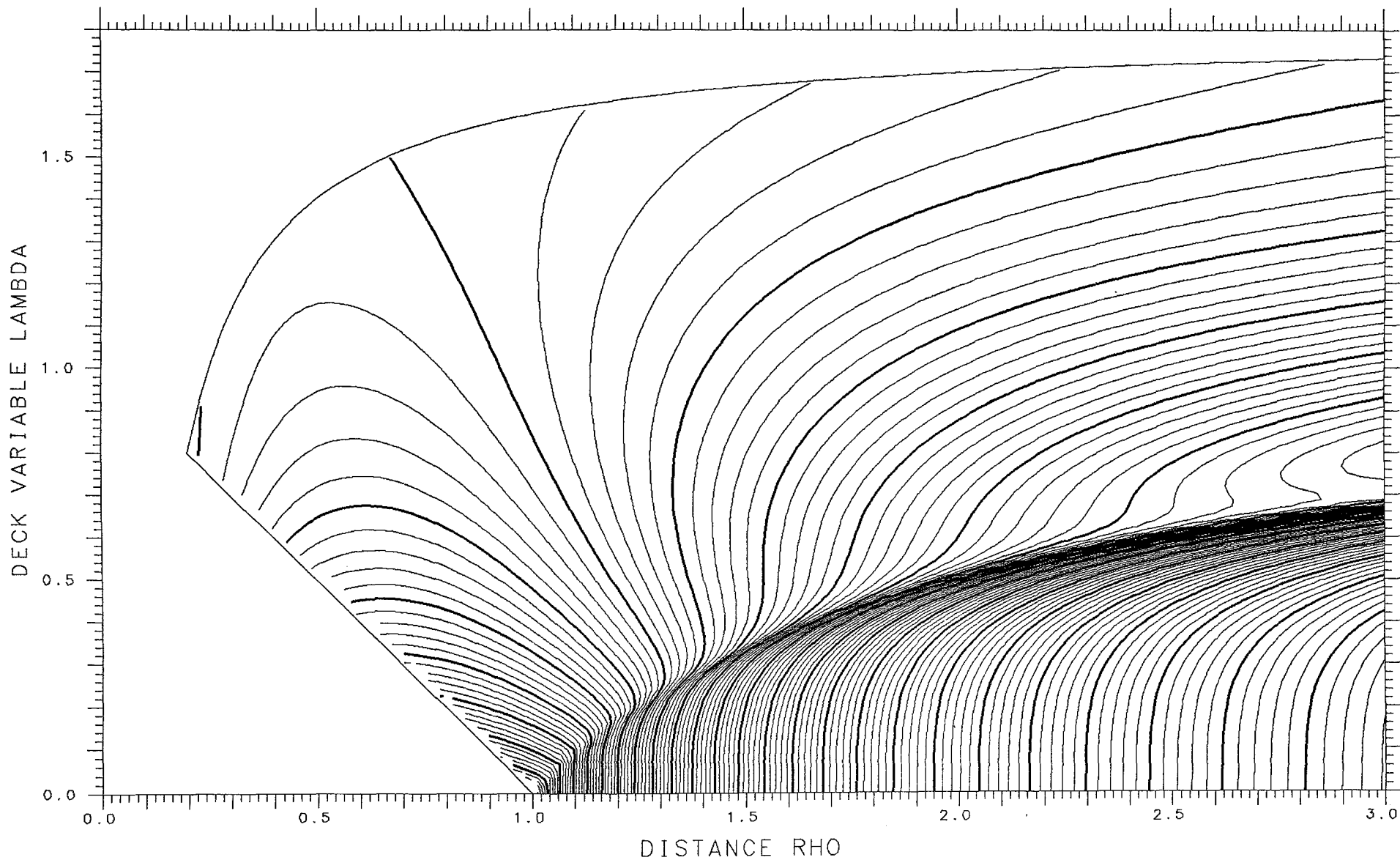

X= .350

ASYMMETRY DELTA= .350 FRACTIONAL= .8996

SPHERES .04992

TANGENT .12361

LENGTH 7.862

ENERGY 351.36

SPACING .005

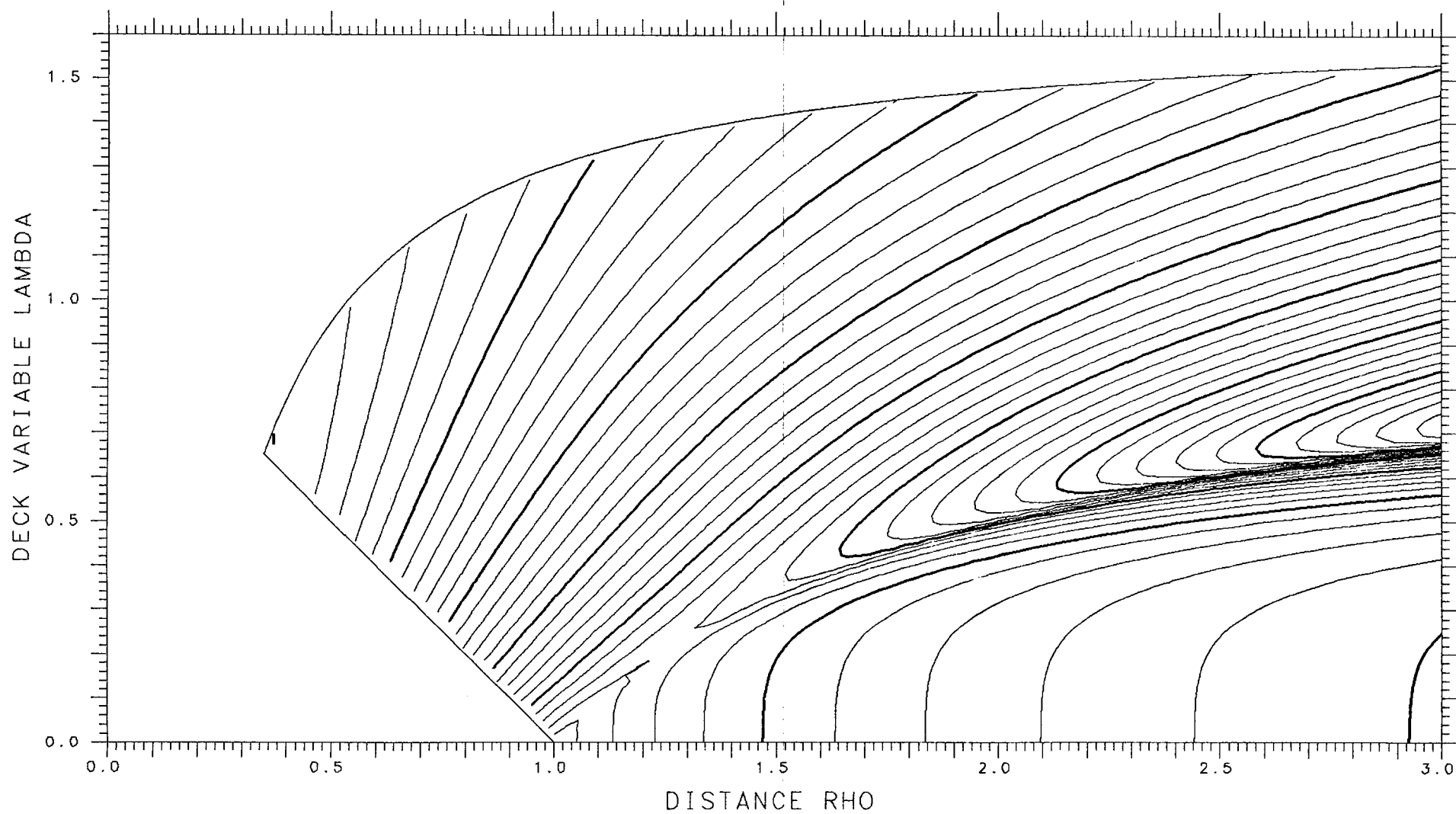

X= .975 ASYMMETRY DELTA= .175 FRACTIONAL= .7429

SPHERES -.33445 TANGENT .06825 LENGTH 12.779 ENERGY 735.16 SPACING .002

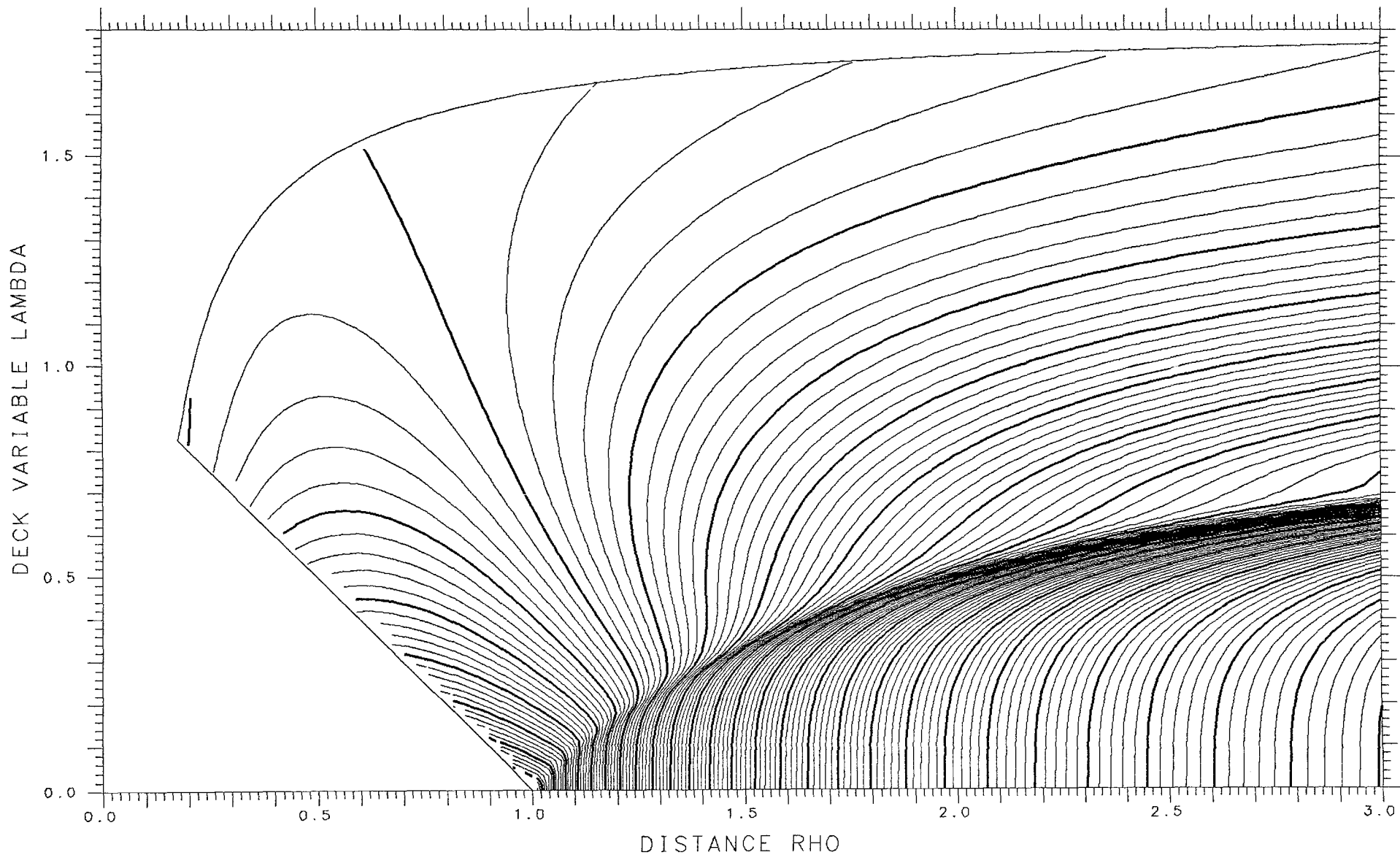

X= .350

ASYMMETRY DELTA= .375

FRACTIONAL= .9141

SPHERES .05095

TANGENT .11581

LENGTH 7.760

ENERGY 351.36

SPACING .005

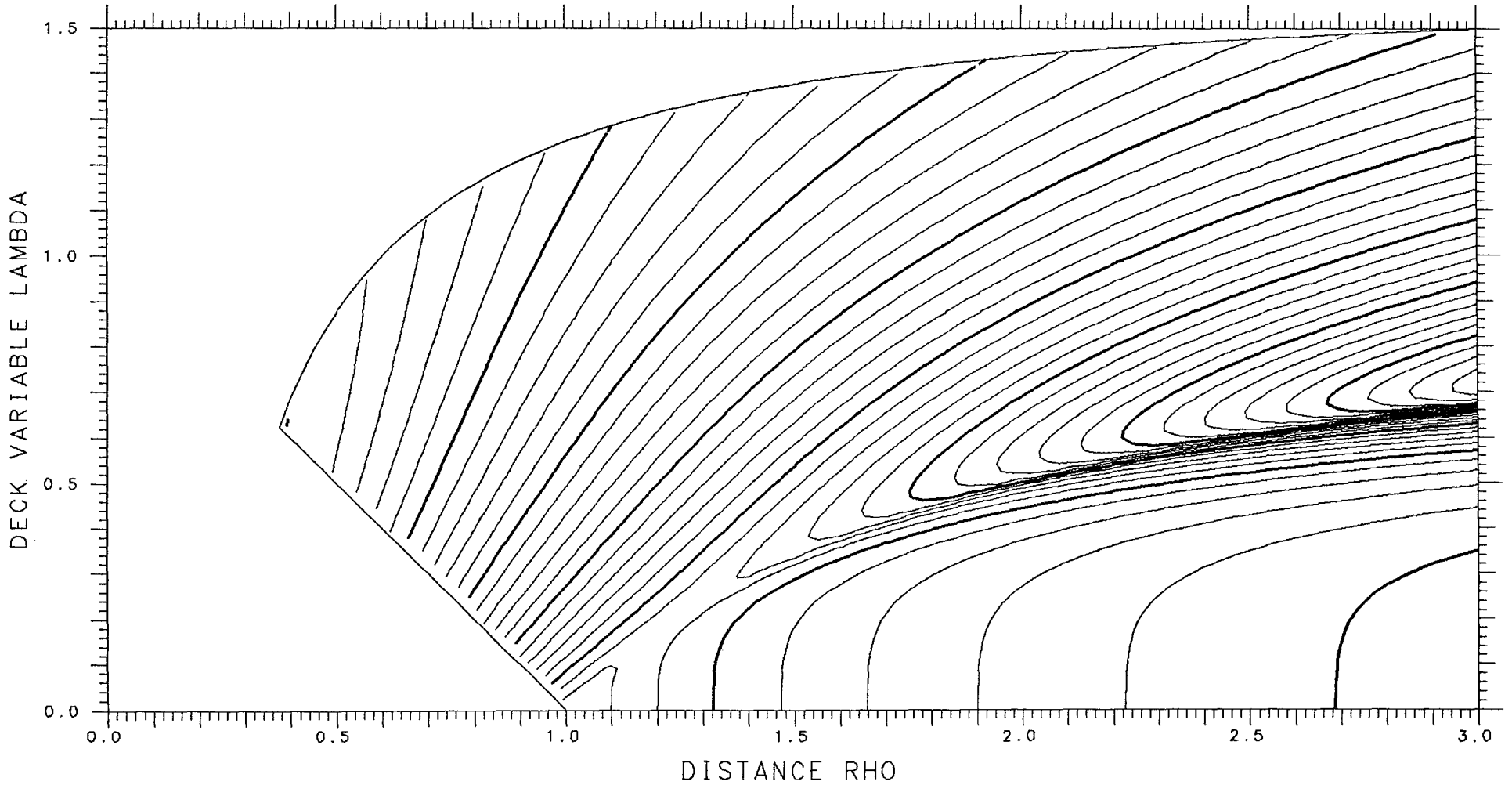

X= .975 ASYMMETRY DELTA= .150 FRACTIONAL= .7124
SPHERES -.36424 TANGENT .06451 LENGTH 12.876 ENERGY 735.16 SPACING .002

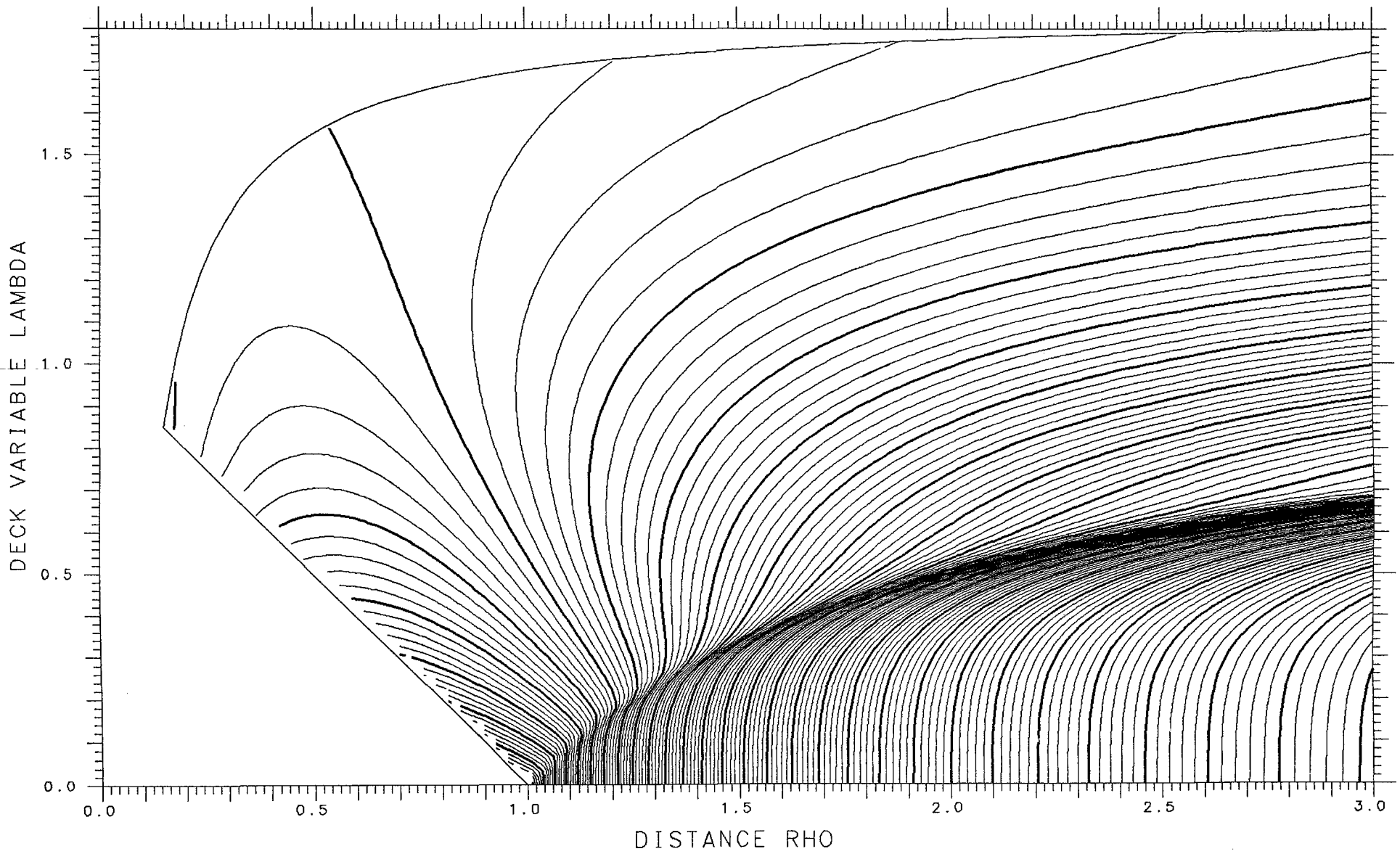

X= .350 ASYMMETRY DELTA= .400 FRACTIONAL= .9270

SPHERES .05124 TANGENT .10790 LENGTH 7.657 ENERGY 351.36 SPACING .005

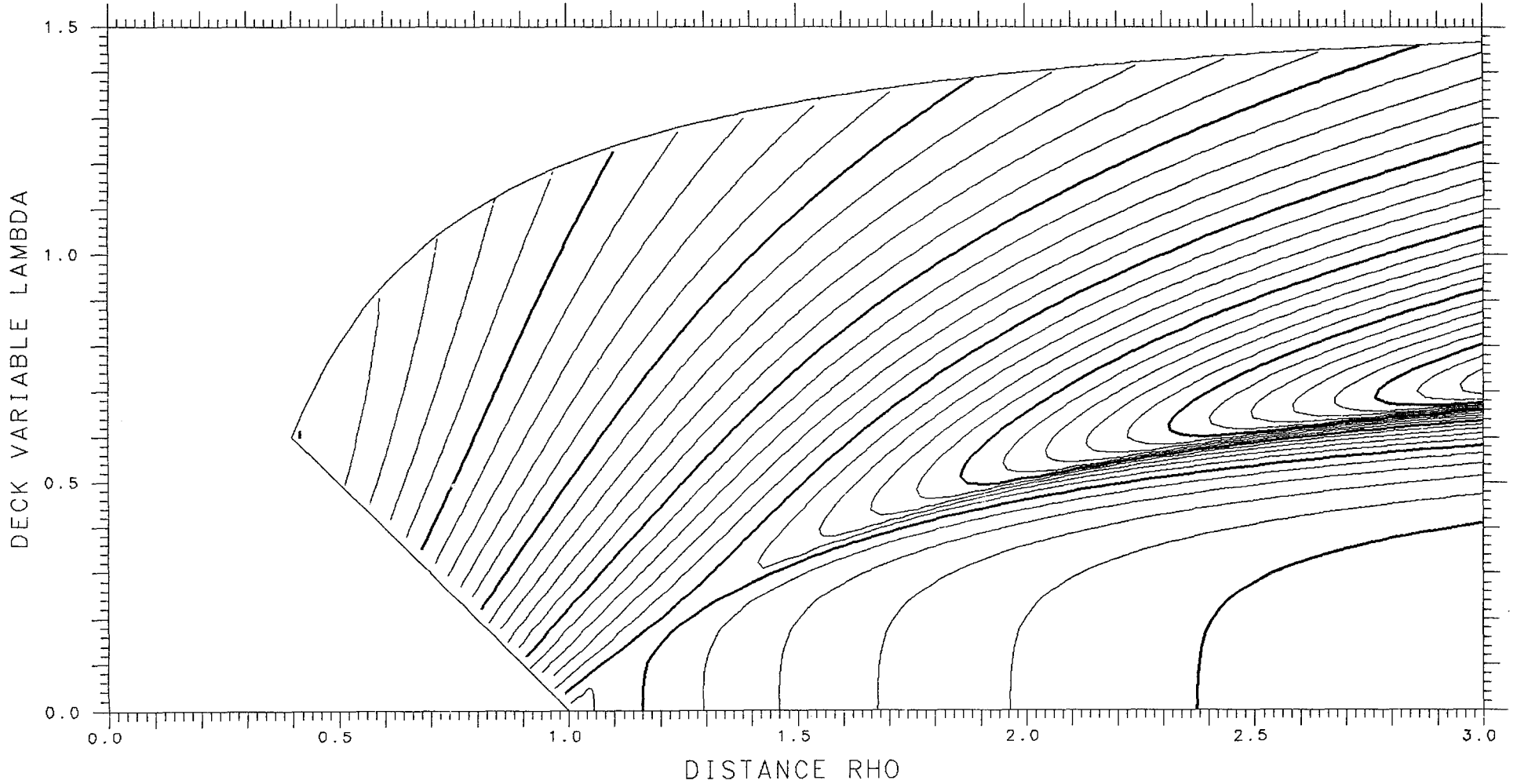

X= .975 ASYMMETRY DELTA= .125 FRACTIONAL= .6800

SPHERES -.39153 TANGENT .06080 LENGTH 12.960 ENERGY 735.16 SPACING .002

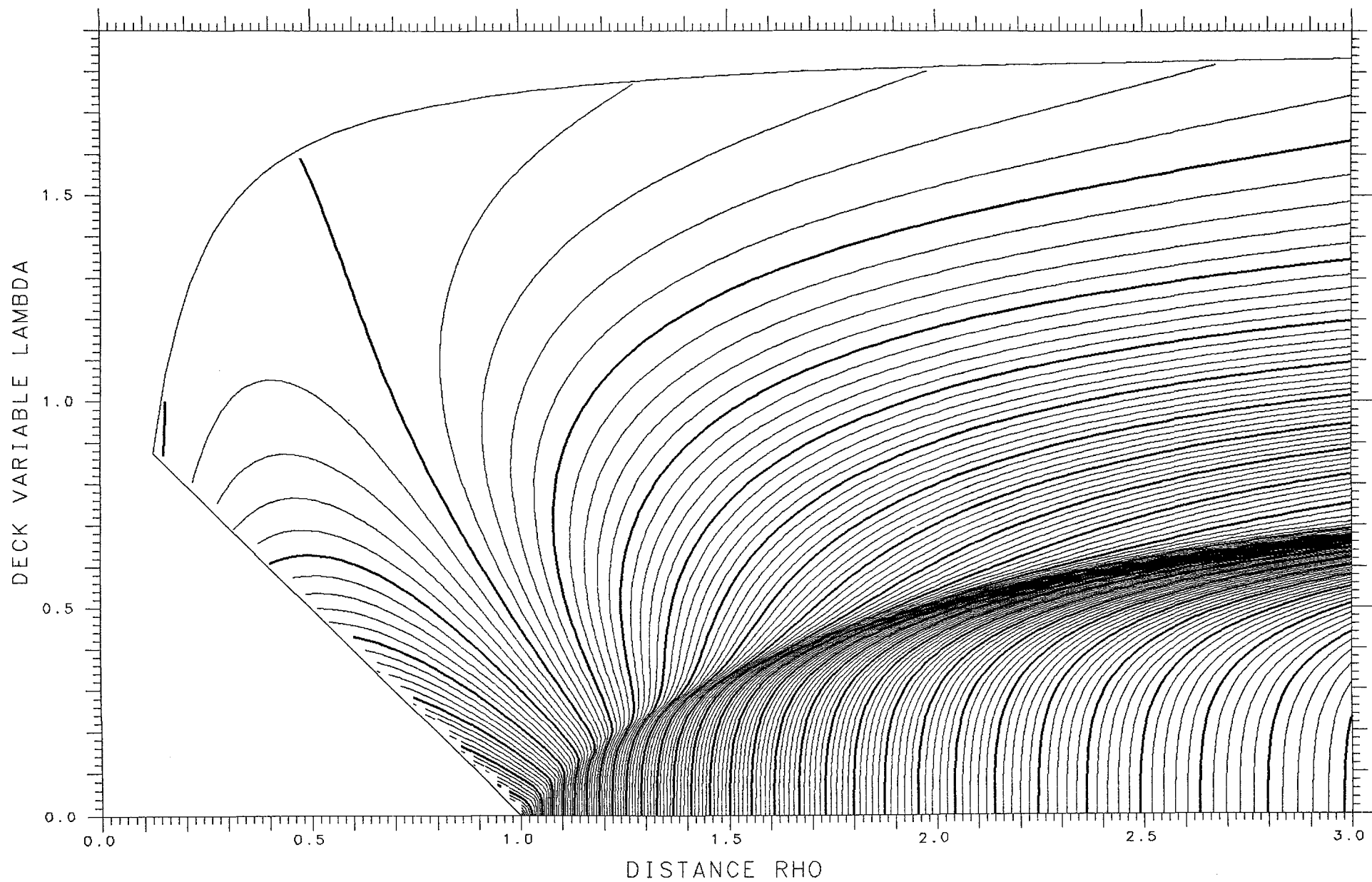

X= .350 ASYMMETRY DELTA= .425 FRACTIONAL= .9384

SPHERES .05082 TANGENT .09994 LENGTH 7.553 ENERGY 351.36 SPACING .005

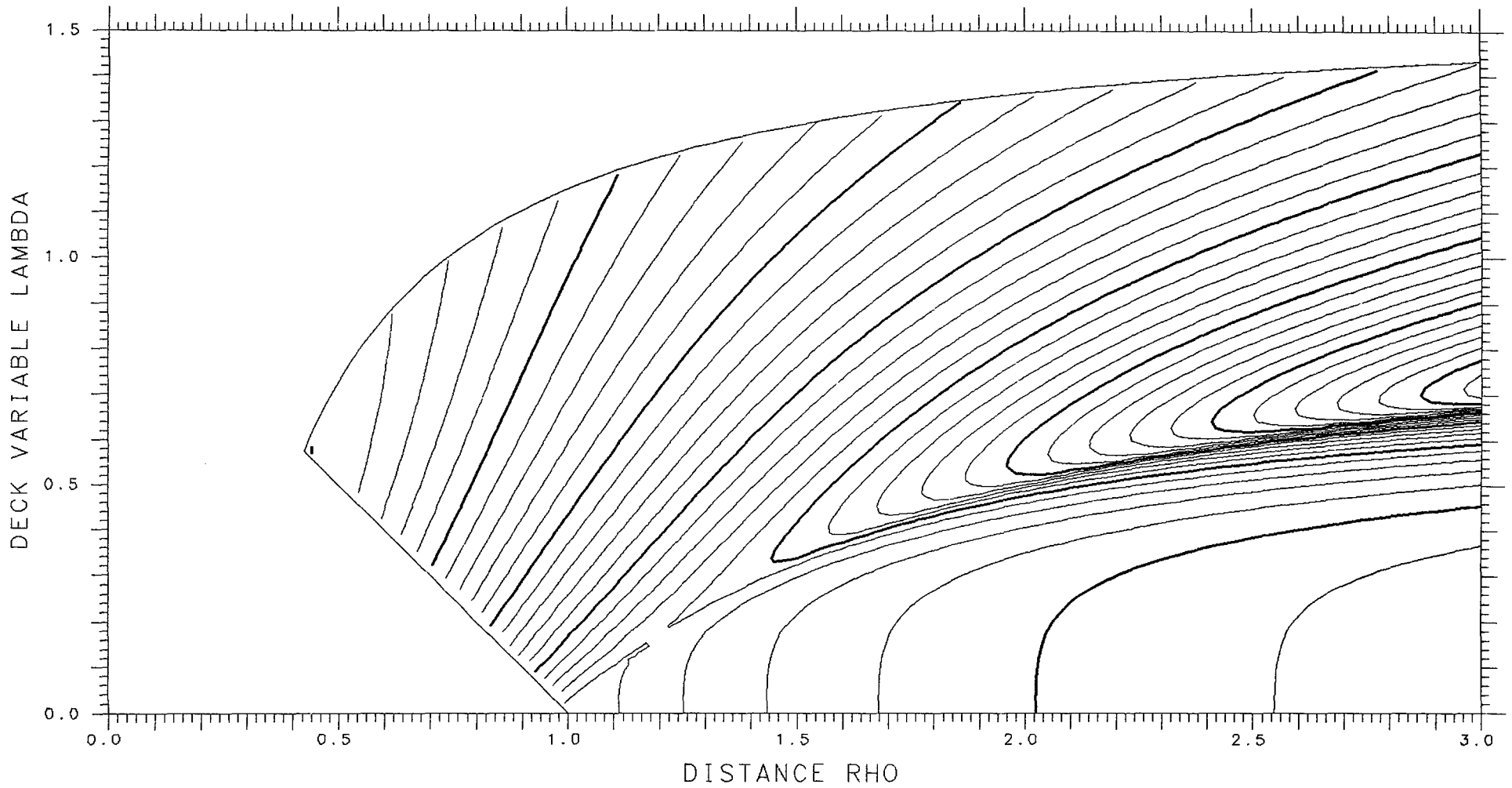

X= .975

ASYMMETRY DELTA= .100

FRACTIONAL= .6461

SPHERES -.41542

TANGENT .05735

LENGTH 13.030

ENERGY 735.16

SPACING .002

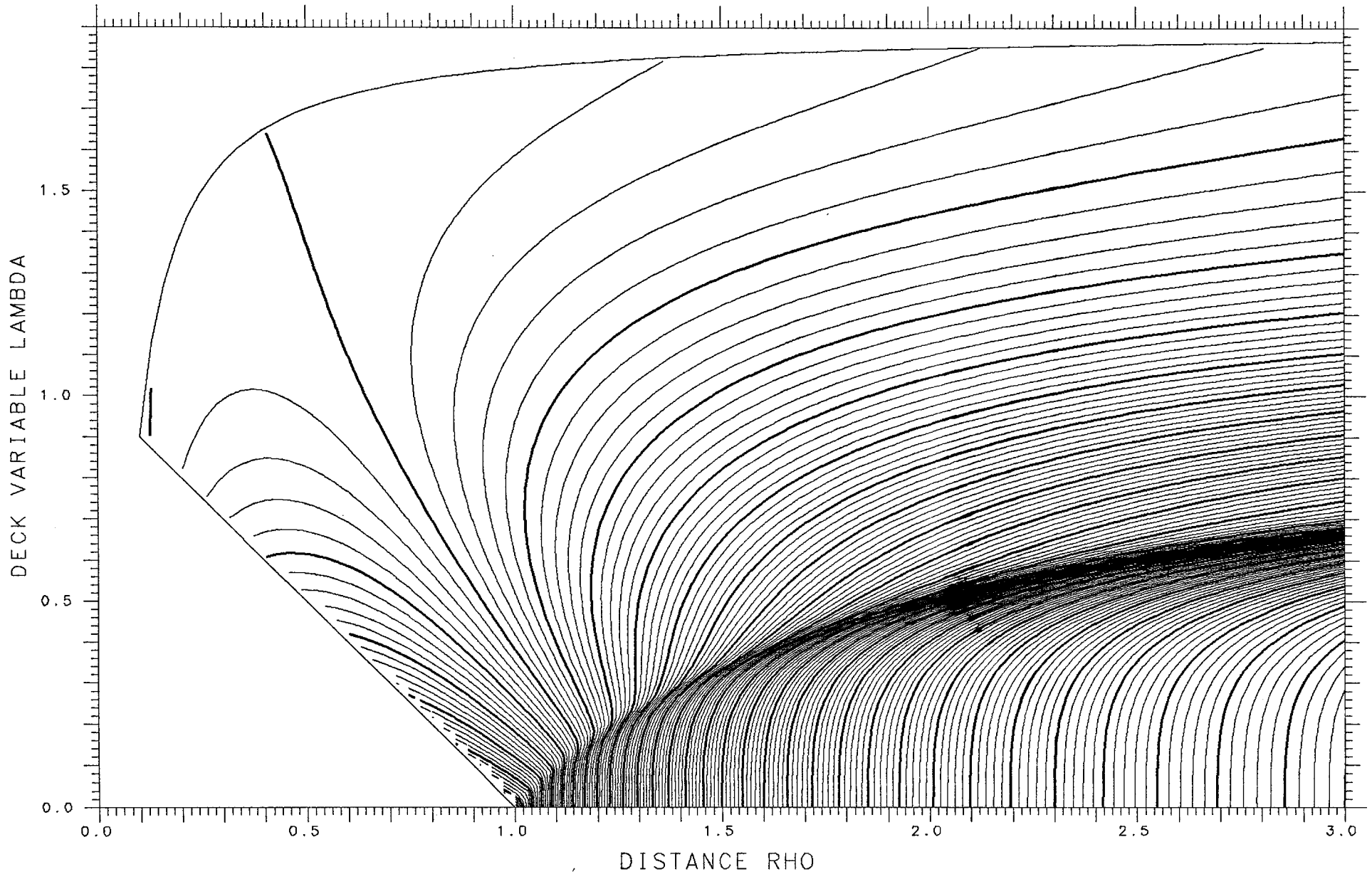

X= .350 ASYMMETRY DELTA= .450 FRACTIONAL= .9483

SPHERES .04977 TANGENT .09202 LENGTH 7.449 ENERGY 351.36 SPACING .005

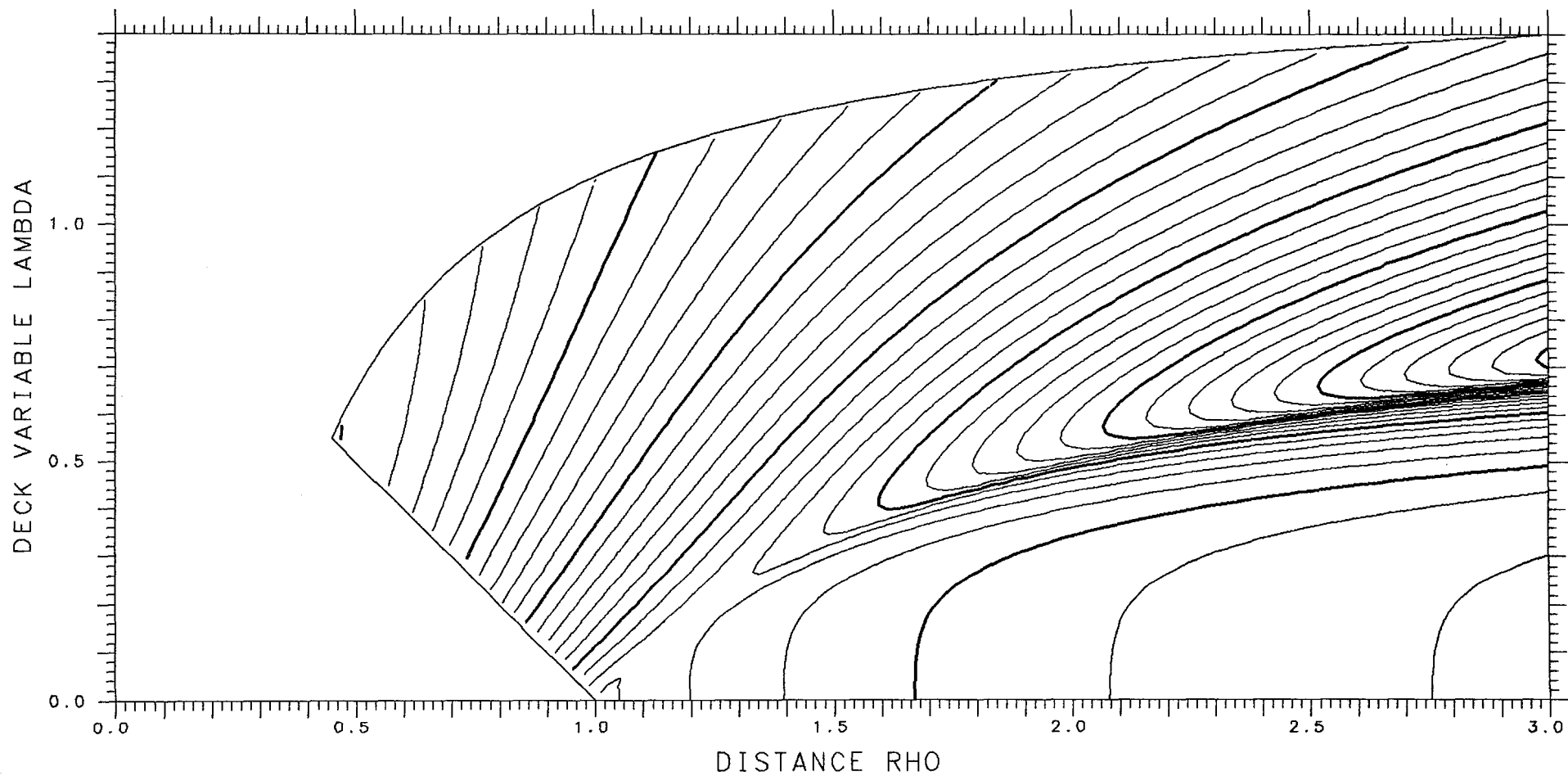

X= .975 ASYMMETRY DELTA= .075 FRACTIONAL= .6108

SPHERES -.43503 TANGENT .05439 LENGTH 13.086 ENERGY 735.16 SPACING .002

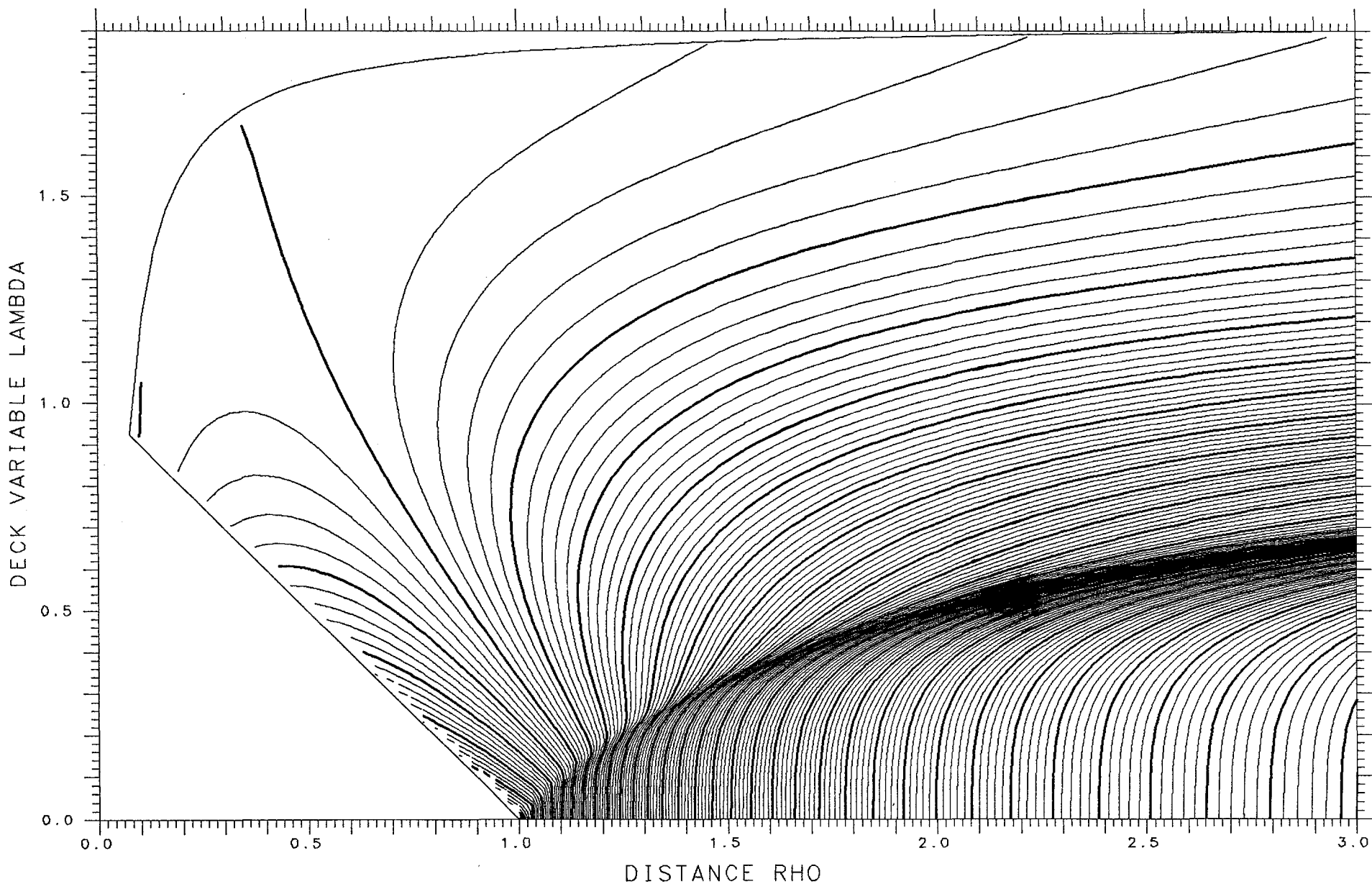

X= .350 ASYMMETRY DELTA= .475 FRACTIONAL= .9569

SPHERES .04815 TANGENT .08420 LENGTH 7.345 ENERGY 351.36 SPACING .005

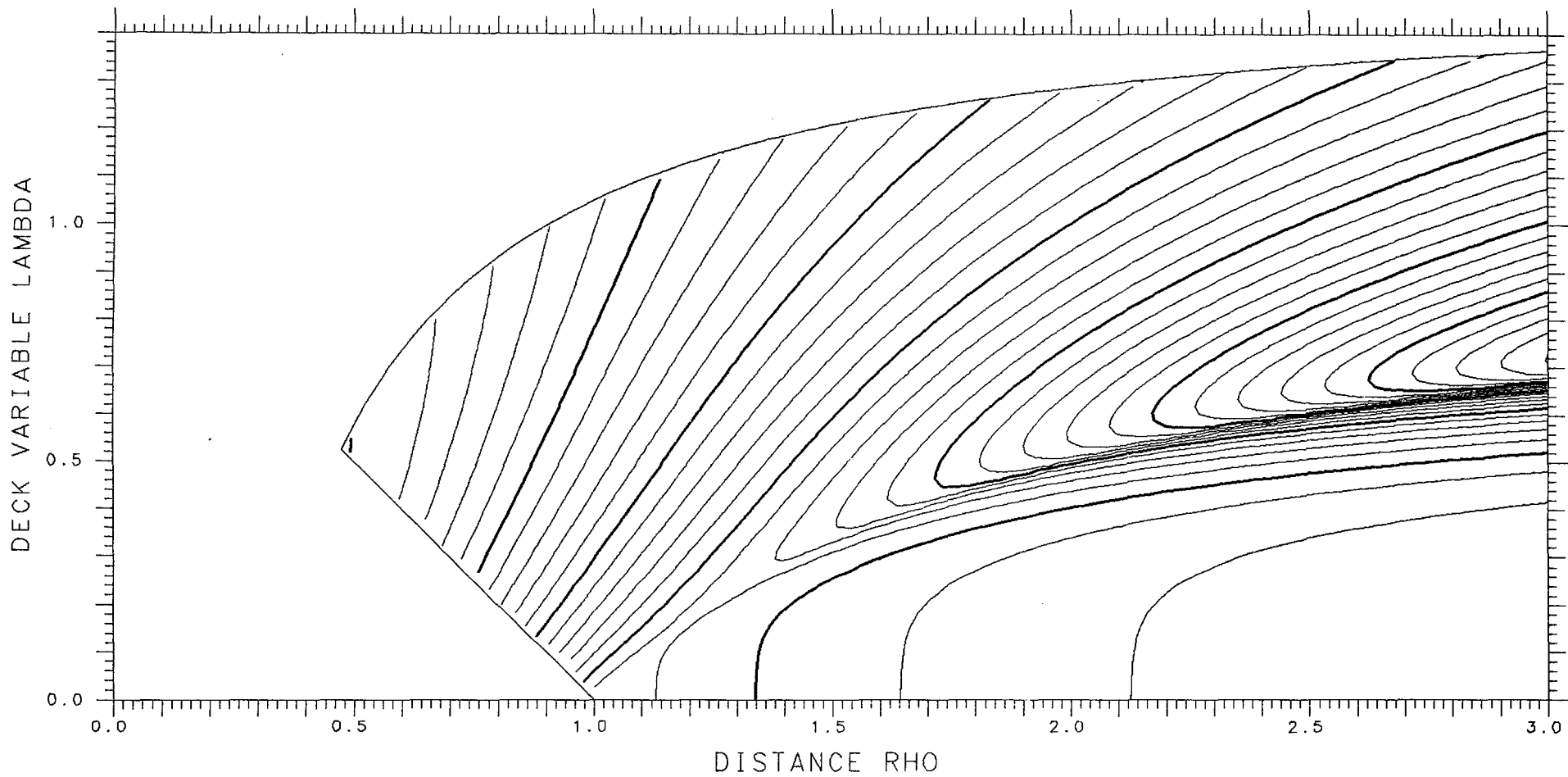

X= .975

ASYMMETRY DELTA= .050

FRACTIONAL= .5745

SPHERES -.44962

TANGENT .05211

LENGTH **13.126**

ENERGY 735.16

SPACING .002

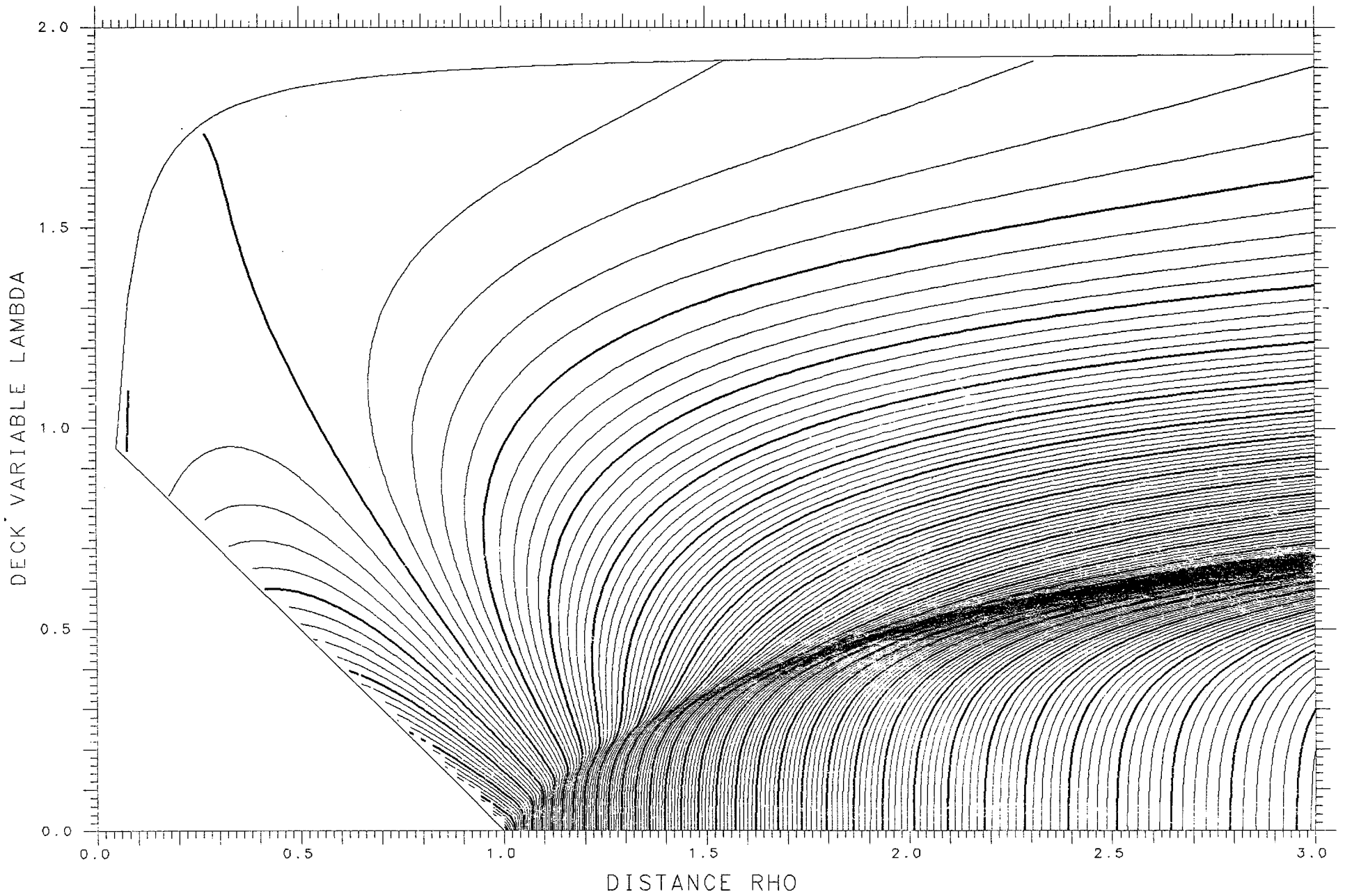

X= .400

ASYMMETRY DELTA=0.

FRACTIONAL= .5000

SPHERES -.03611

TANGENT .17388

LENGTH 9.201

ENERGY 388.03

SPACING .005

SADDLE .13344

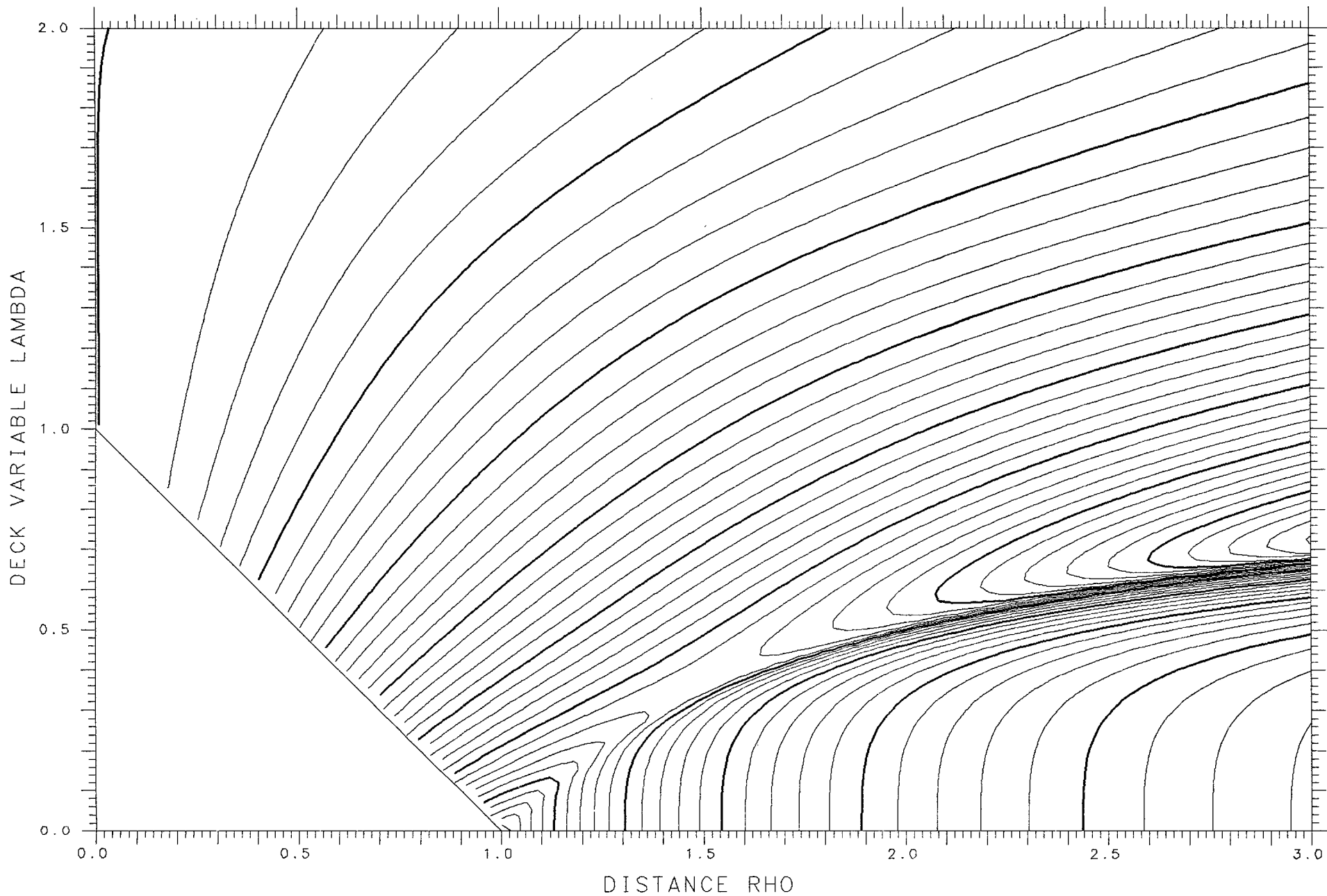

X= .975

ASYMMETRY DELTA= .025

FRACTIONAL= .5374

SPHERES -.45862

TANGENT .05068

LENGTH 13.151

ENERGY 735.16

SPACING .002

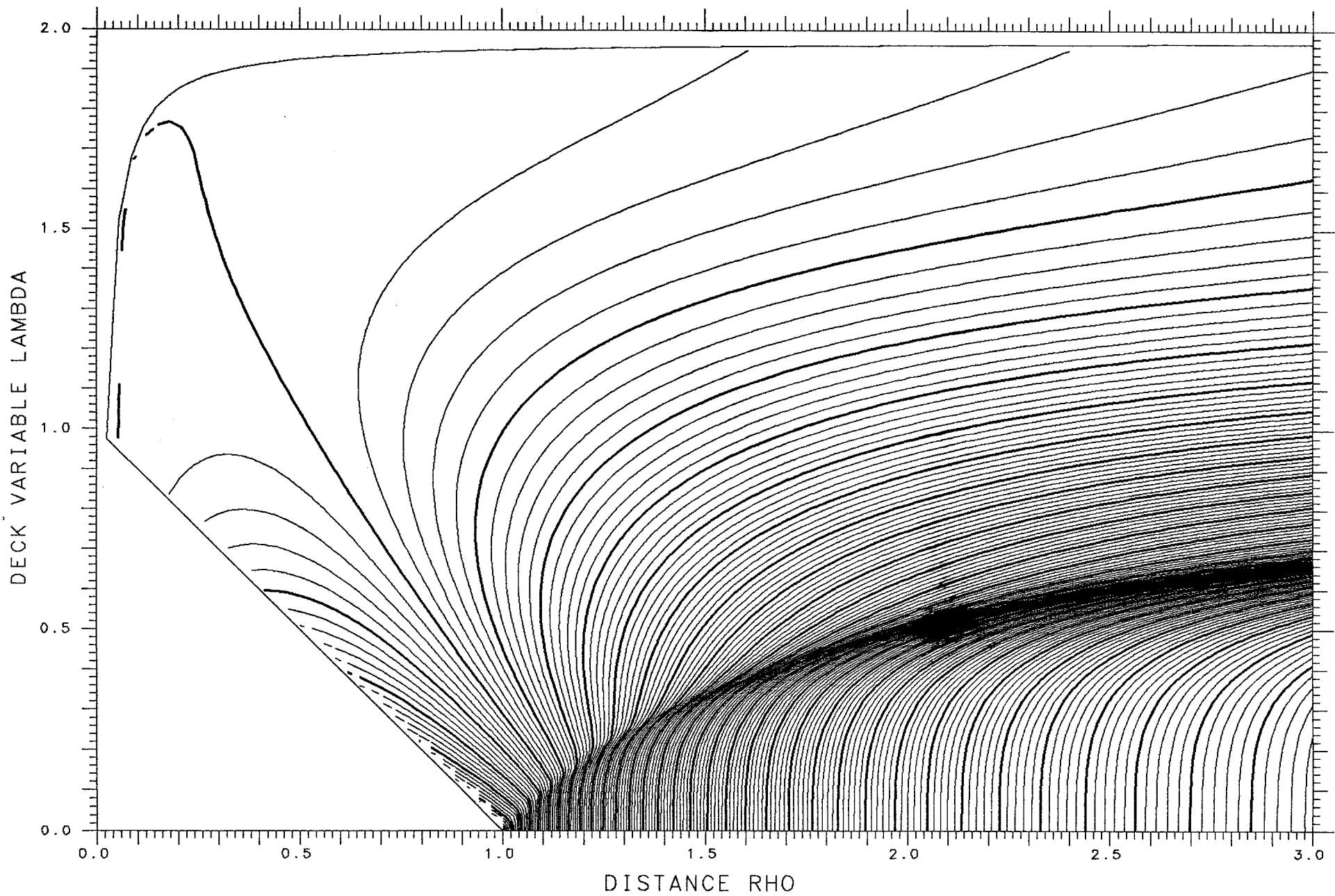

x = .400

ASYMMETRY DELTA = .025

FRACTIONAL = .5374

SPHERES - .03533

TANGENT .17361

LENGTH 9.196

ENERGY 388.03

SPACING .005

SADDLE .13345

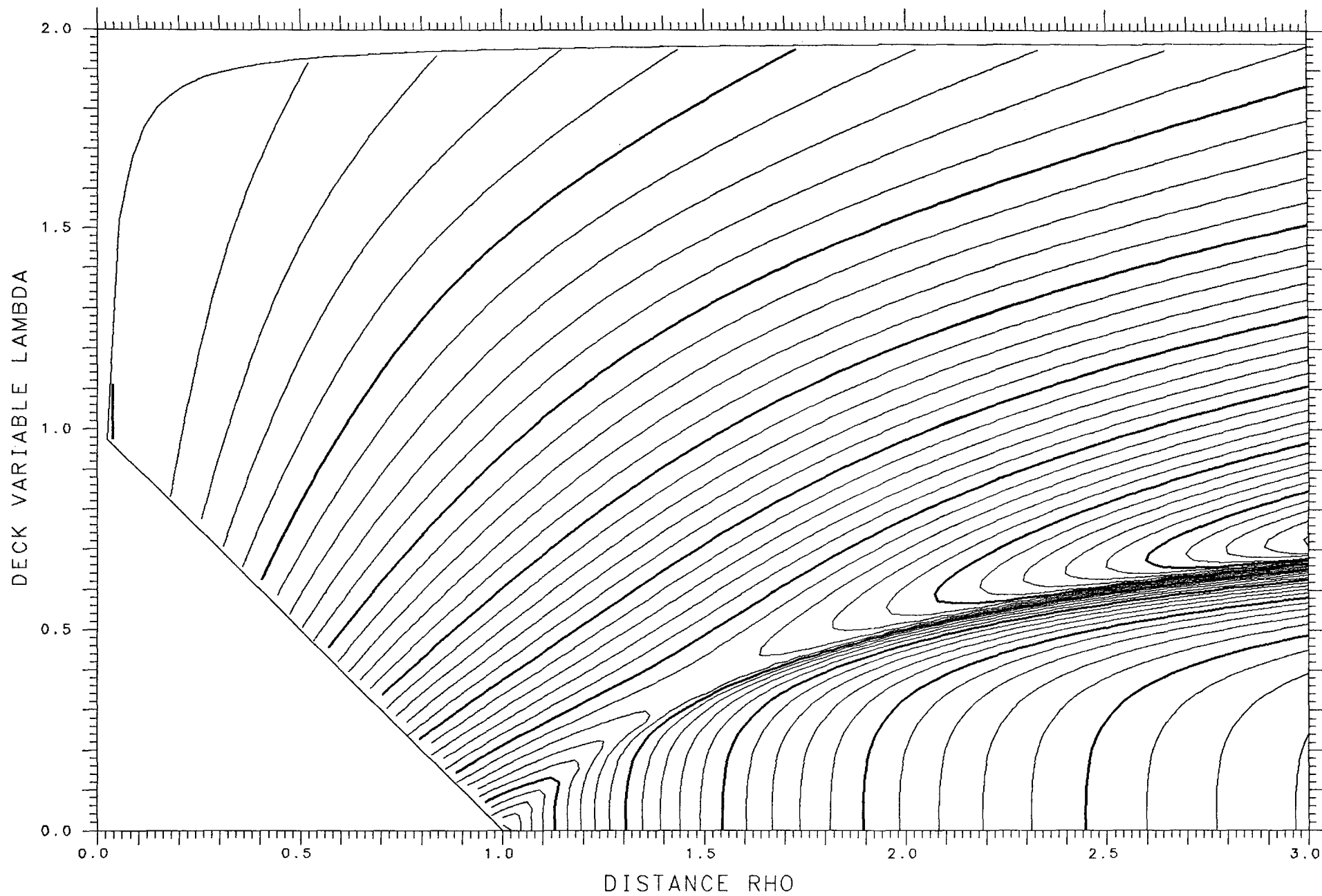

X= .975

ASYMMETRY DELTA=0.

FRACTIONAL= .5000

SPHERES -.46166

TANGENT .05019

LENGTH 13.159

ENERGY 735.16

SPACING .002

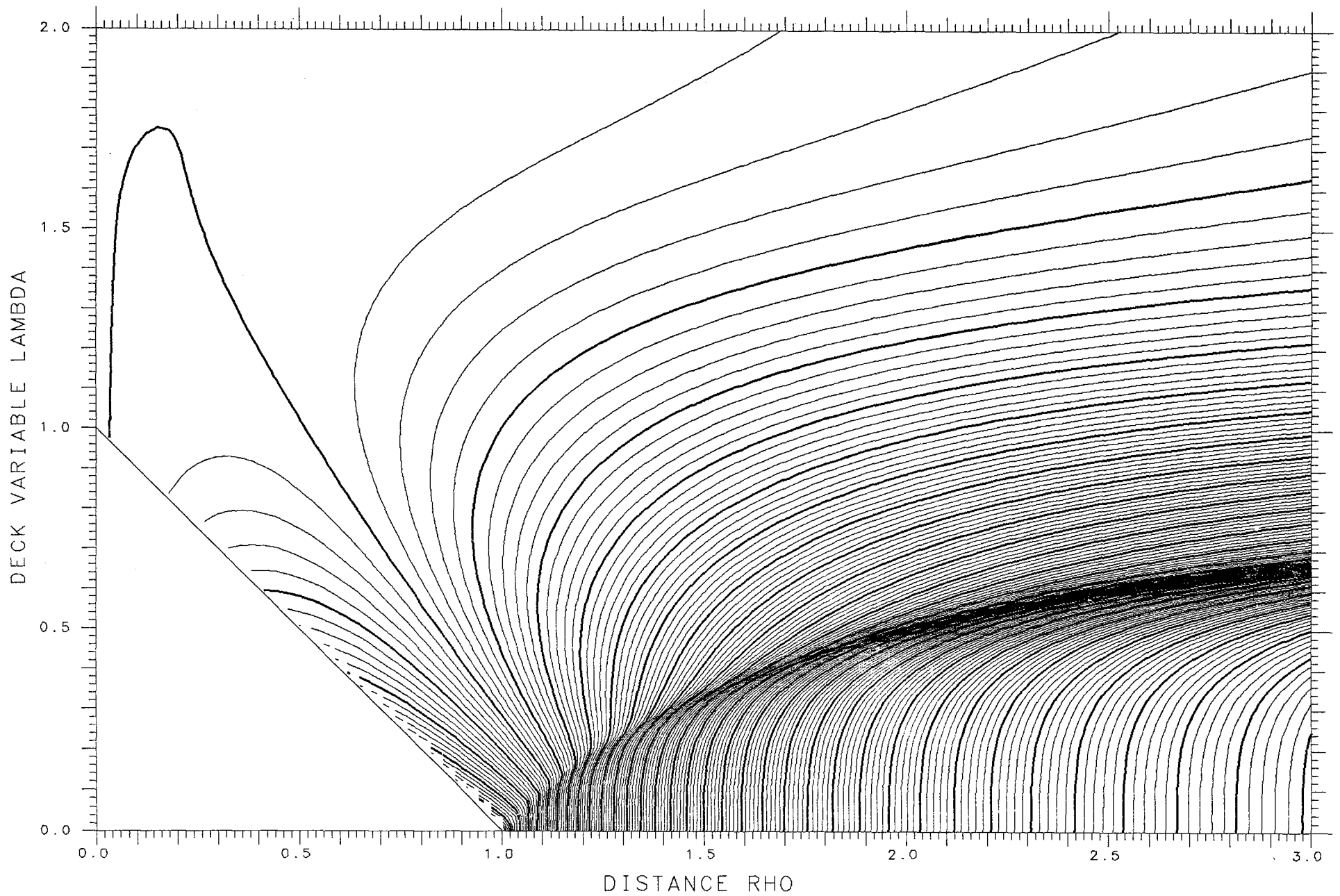

DECK VARIABLE LAMBDA

X = .400 ASYMMETRY DELTA = .050 FRACTIONAL = .5745

SPHERES = .03302 TANGENT .17282 LENGTH 9.178 ENERGY 388.03 SPACING .005 SADDLE .13345

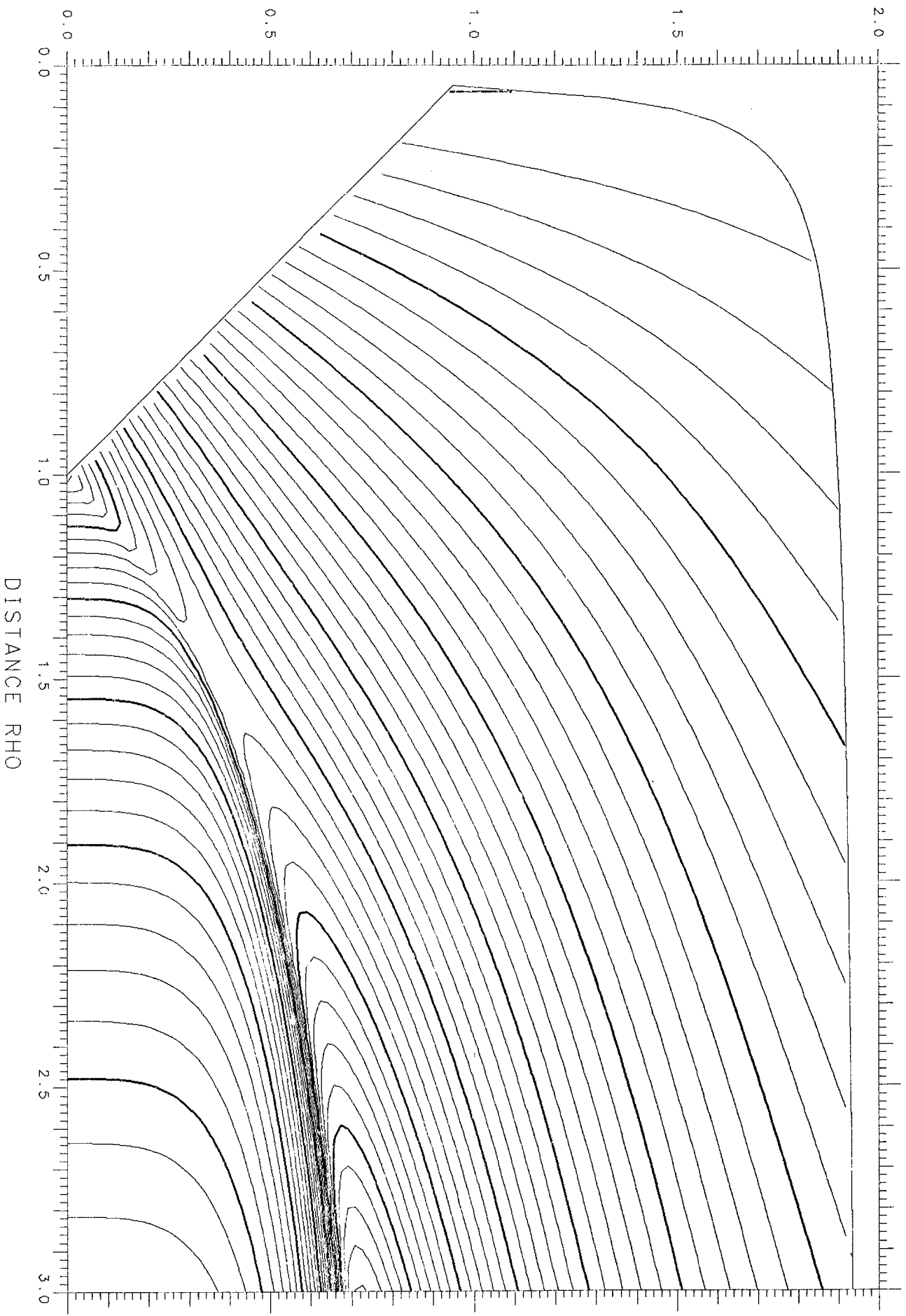

X= .950 ASYMMETRY DELTA= .600 FRACTIONAL= .9846

SPHERES .00491 TANGENT .04349 LENGTH 10.203 ENERGY 722.20 SPACING .002

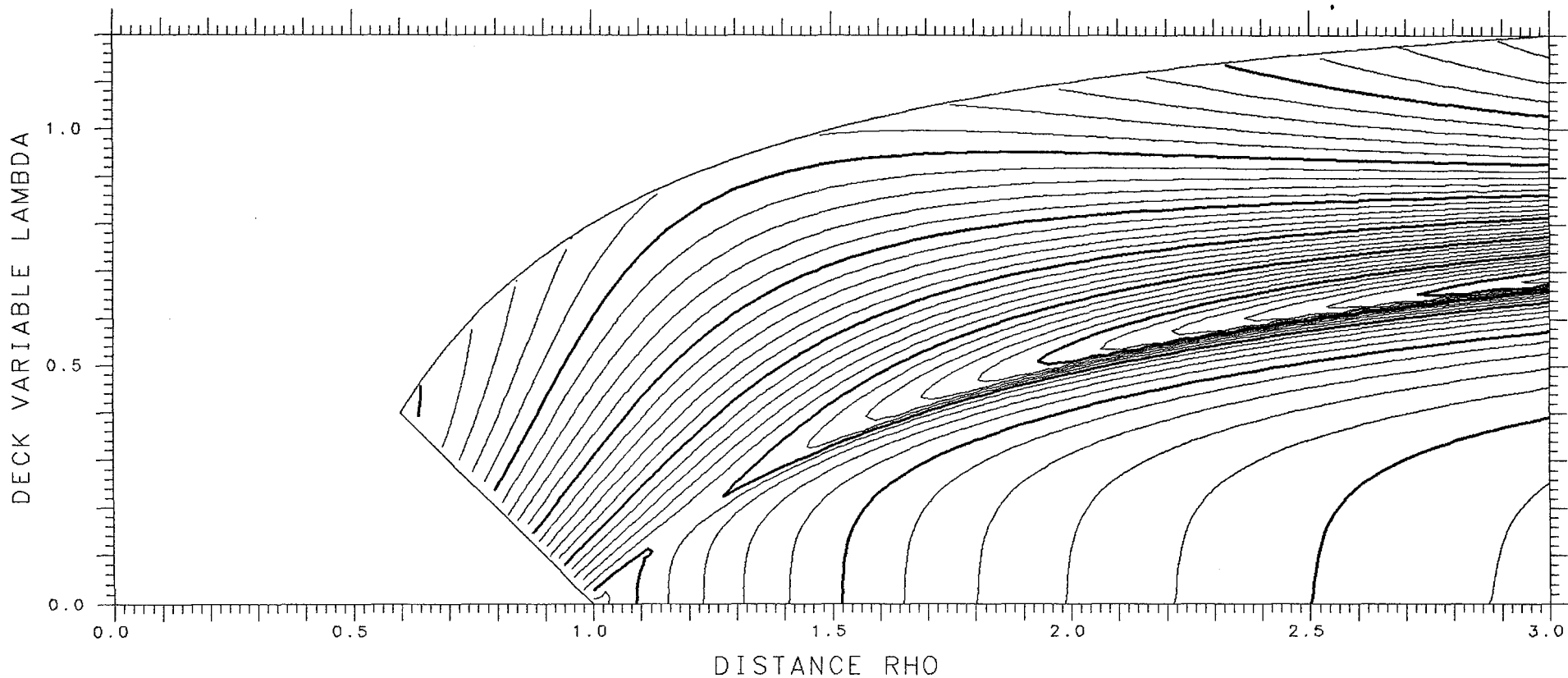

X= .400 ASYMMETRY DELTA= .075 FRACTIONAL= .6108

SPHERES -.02930 TANGENT .17149 LENGTH 9.150 ENERGY 388.03 SPACING .005 SADDLE .13340

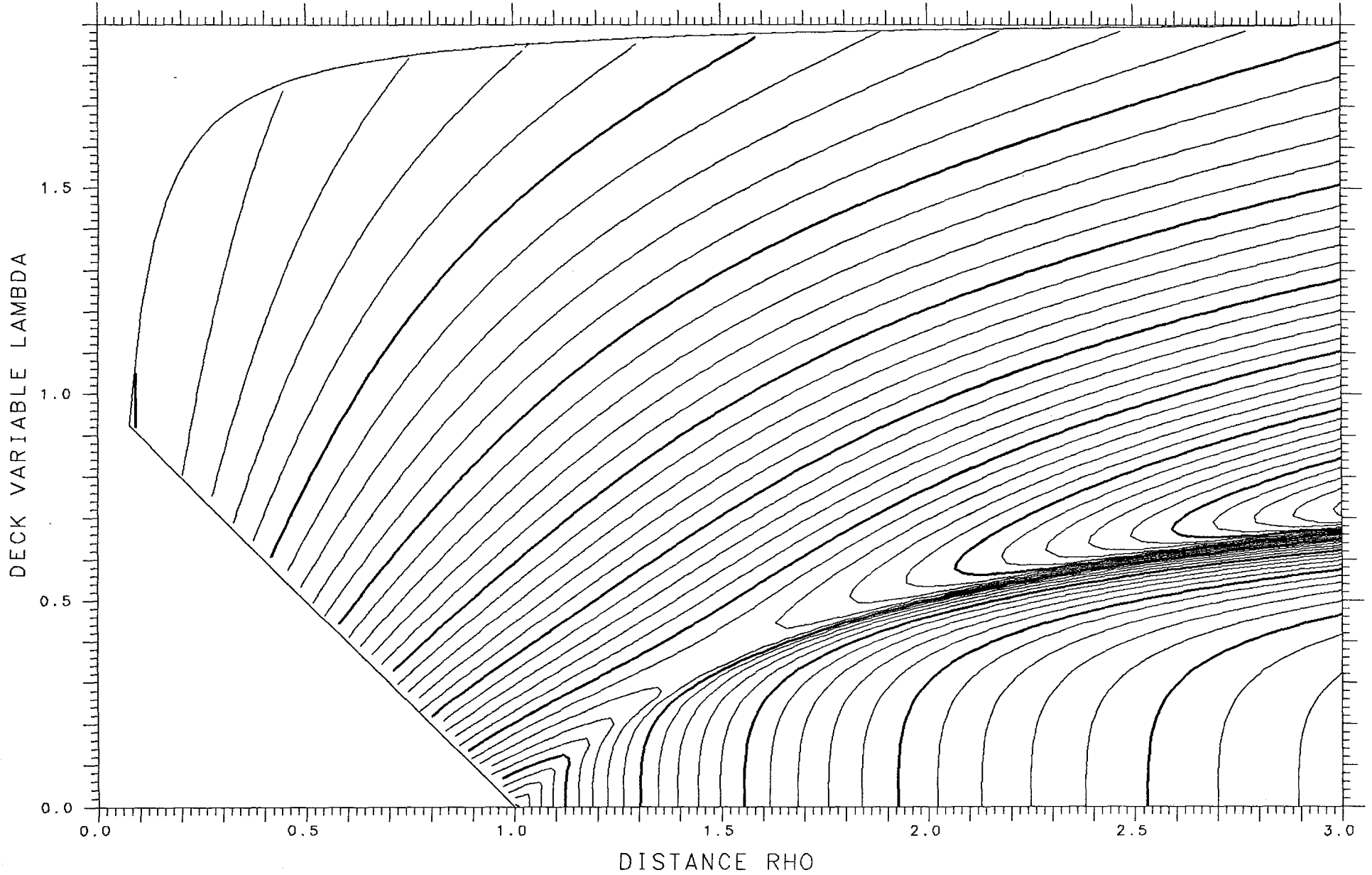

X= .950 ASYMMETRY DELTA= .575 FRACTIONAL= .9807

SPHERES .00099 TANGENT .04843 LENGTH 10.351 ENERGY 722.20 SPACING .002

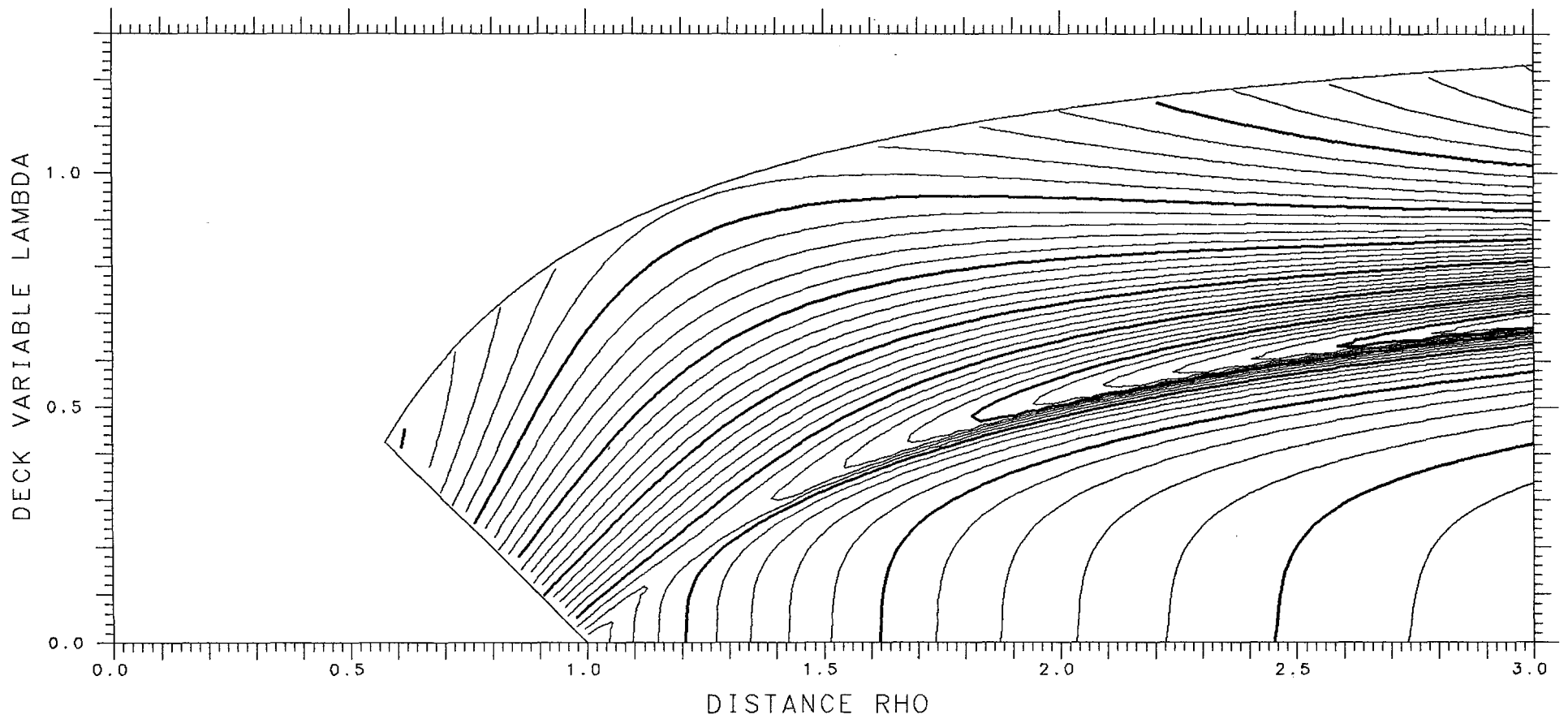

X= .400 ASYMMETRY DELTA= .100 FRACTIONAL= .6461

SPHERES -.02435 TANGENT .16960 LENGTH 9.111 ENERGY 388.03 SPACING .005 SADDLE .13324

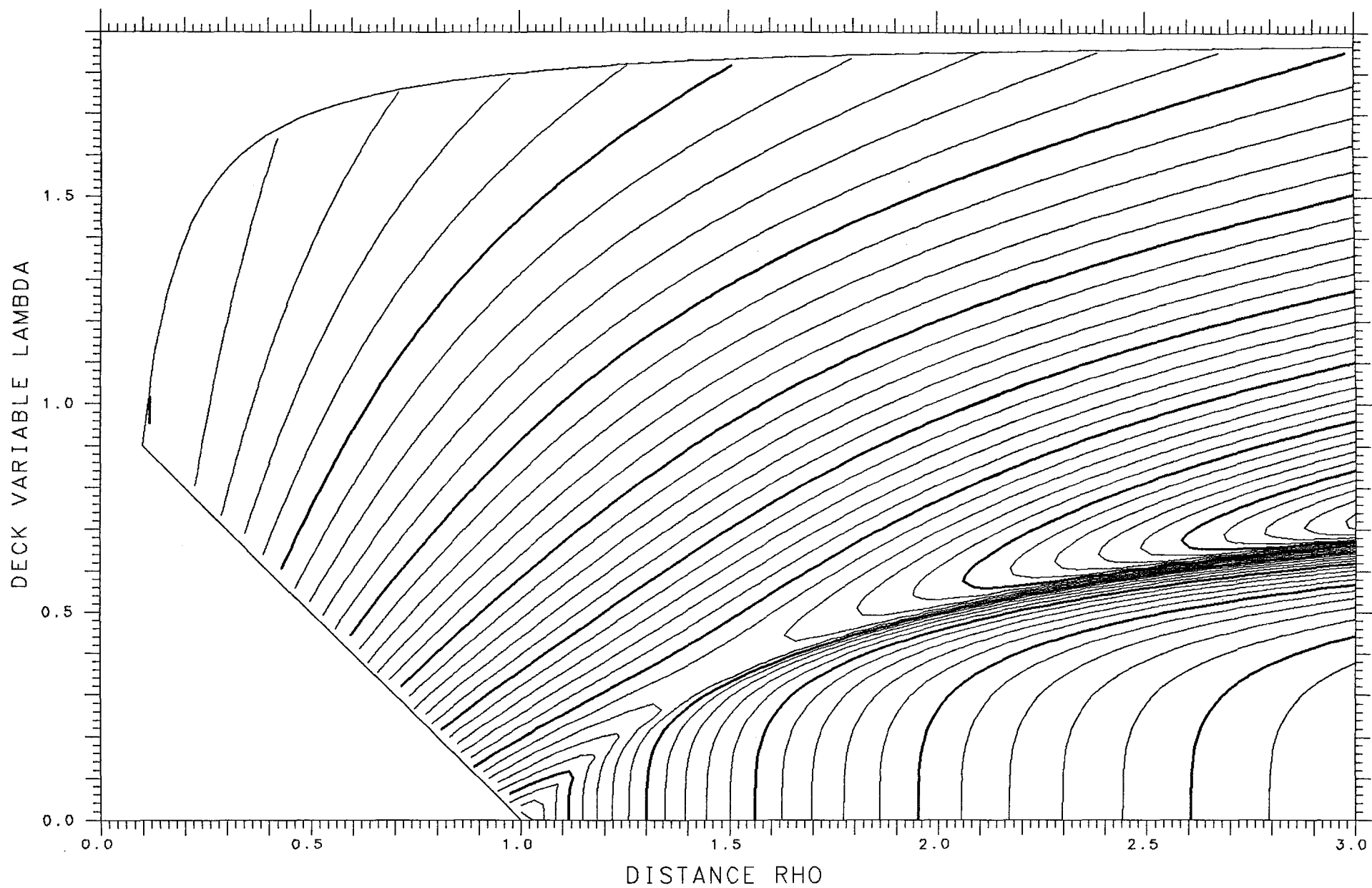

X= .950 ASYMMETRY DELTA= .550 FRACTIONAL= .9761

SPHERES -.00432 TANGENT .05336 LENGTH 10.502 ENERGY 722.20 SPACING .002

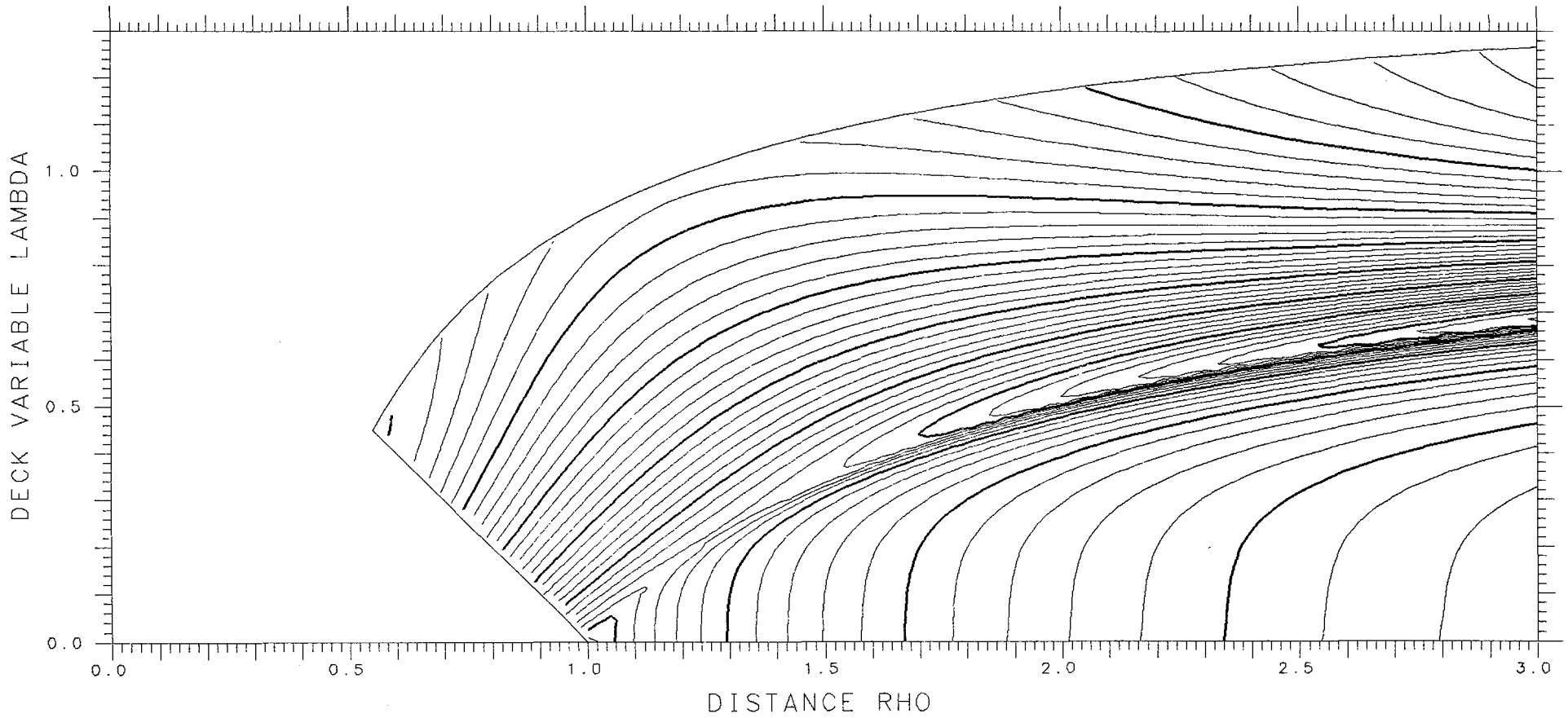

X= .400 ASYMMETRY DELTA= .125 FRACTIONAL= .6800

SPHERES -.01843 TANGENT .16714 LENGTH 9.062 ENERGY 388.03 SPACING .005 SADDLE .13289

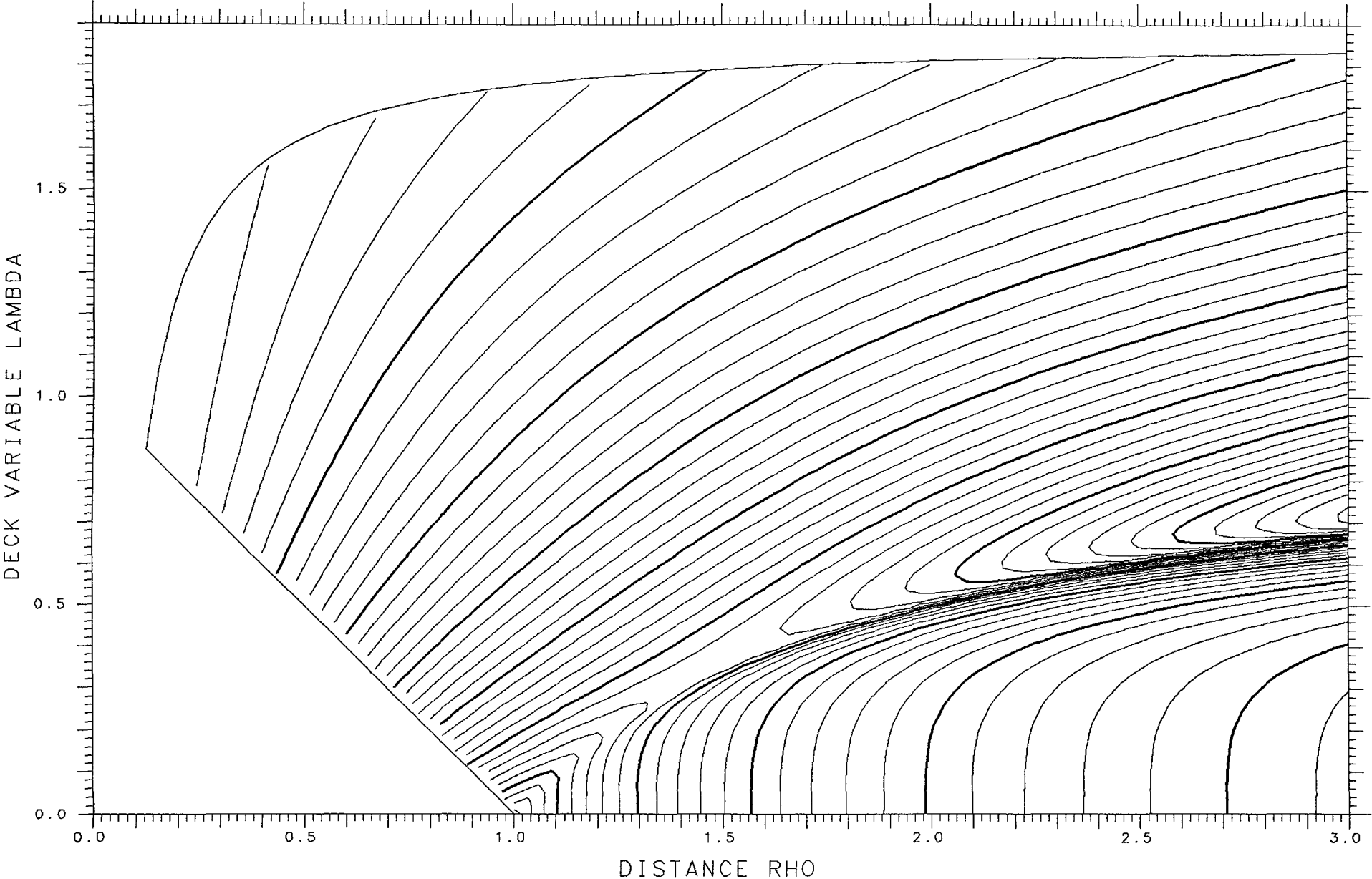

X = .950 ASYMMETRY DELTA = .525 FRACTIONAL = .9707
SPHERES = .01121 TANGENT = .05822 LENGTH 10.654 ENERGY 722.20 SPACING .002

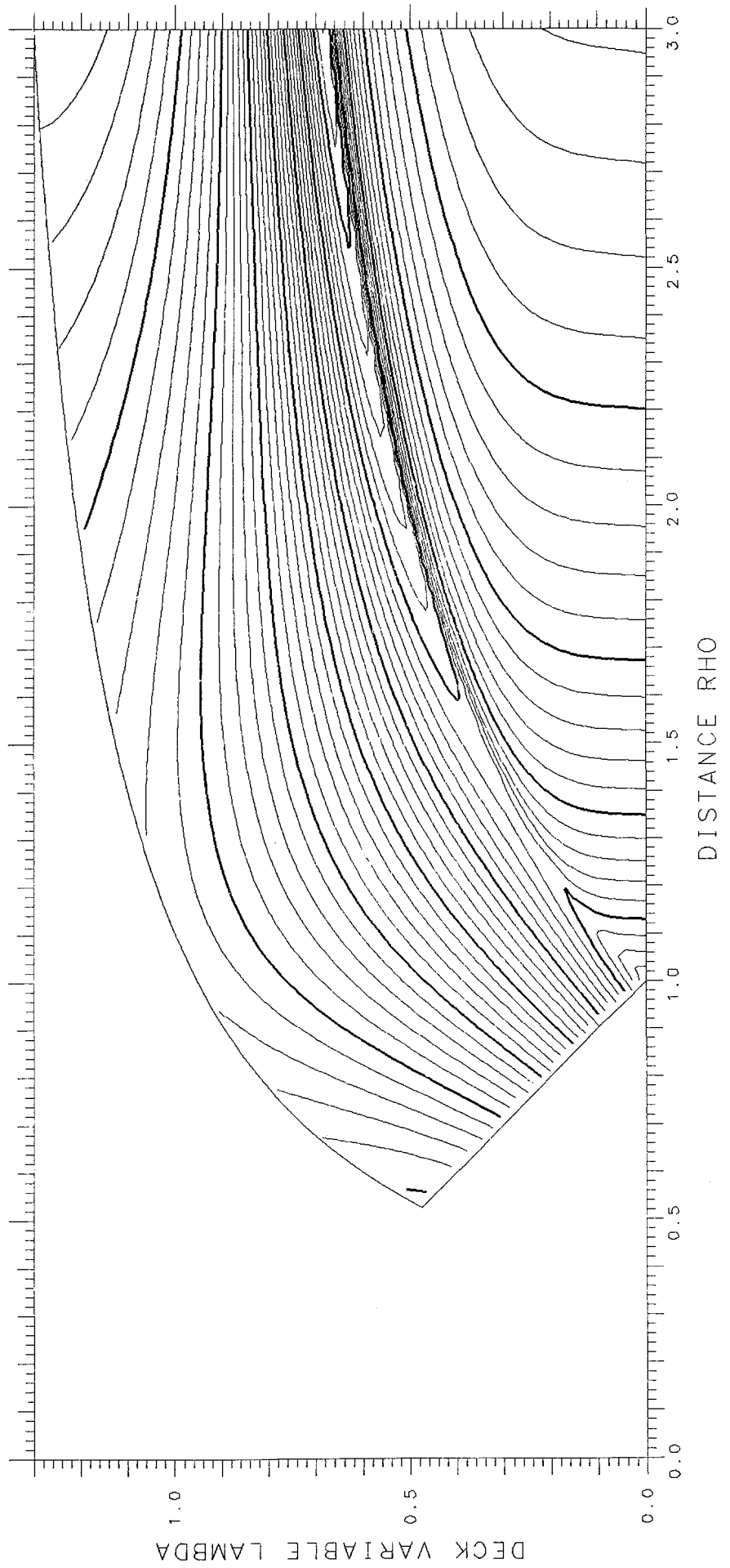

X= .400 ASYMMETRY DELTA= .150 FRACTIONAL= .7124

SPHERES -.01180 TANGENT .16410 LENGTH 9.003 ENERGY 388.03 SPACING .005 SADDLE .13227

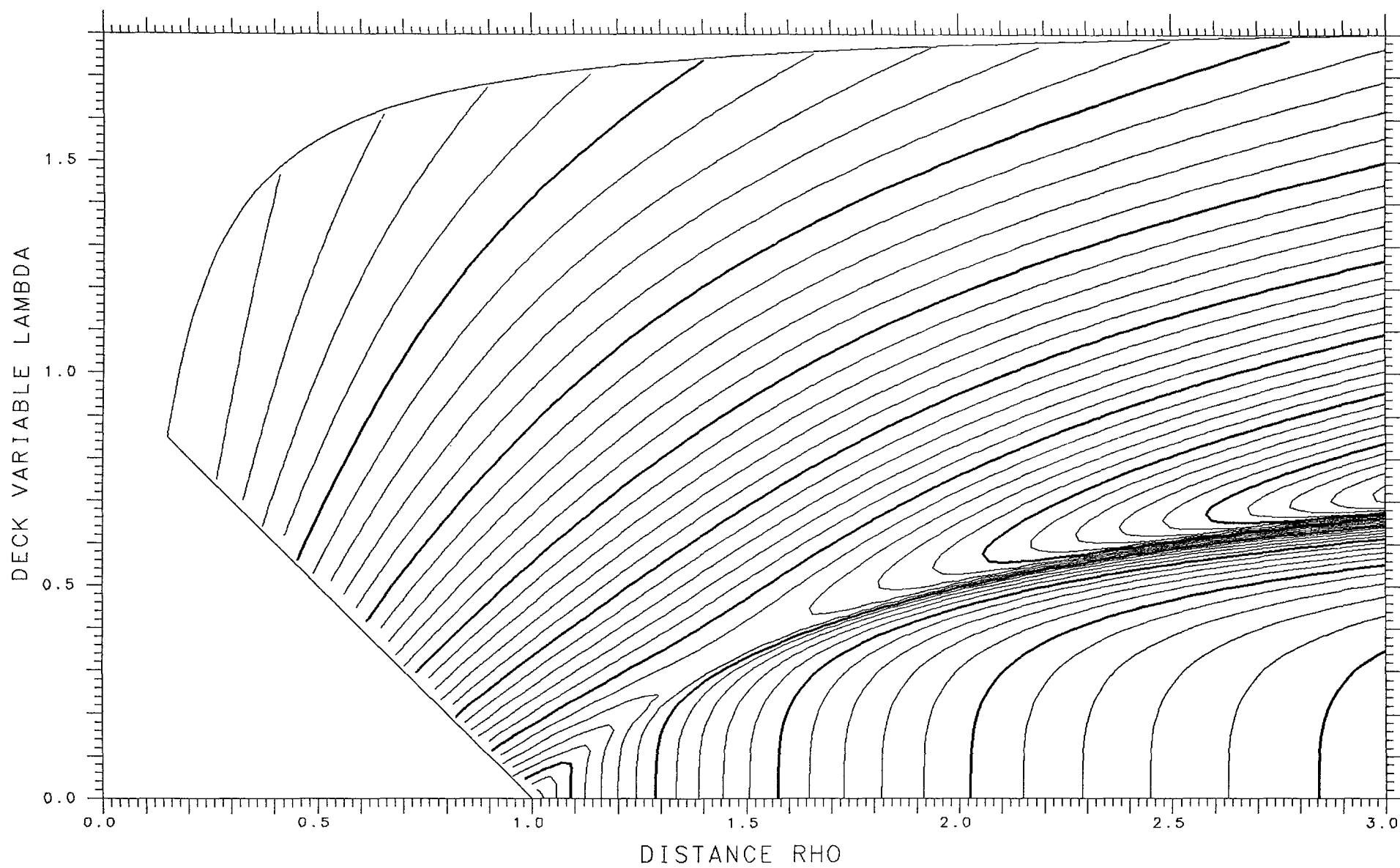

X= .950

ASYMMETRY DELTA= .500

FRACTIONAL= .9643

SPHERES -.01989

TANGENT .06290

LENGTH 10.808

ENERGY 722.20

SPACING .002

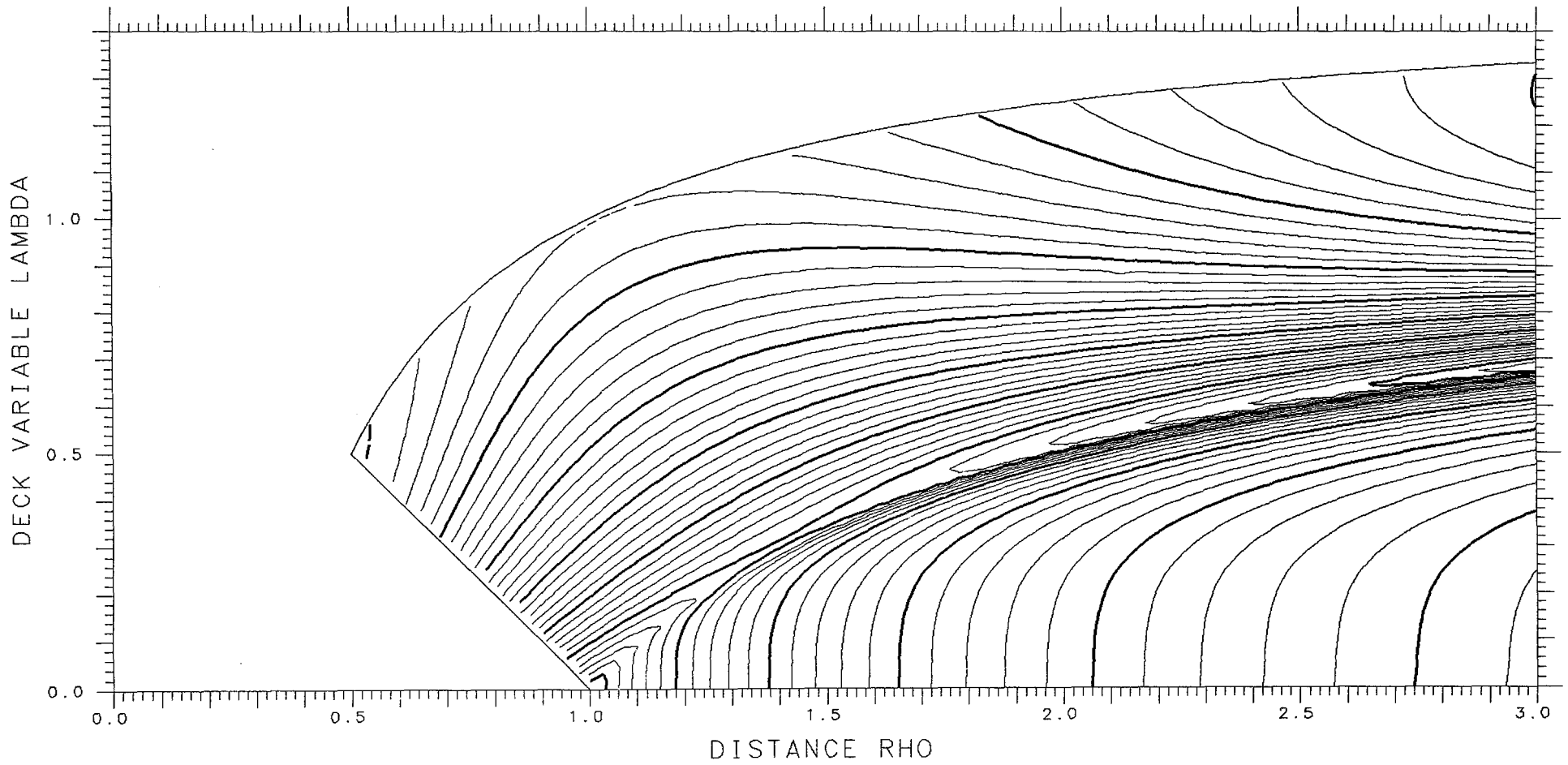

X= .400 ASYMMETRY DELTA= .175 FRACTIONAL= .7429

SPHERES -.00475 TANGENT .16046 LENGTH 8.936 ENERGY 388.03 SPACING .005 SADDLE .13128

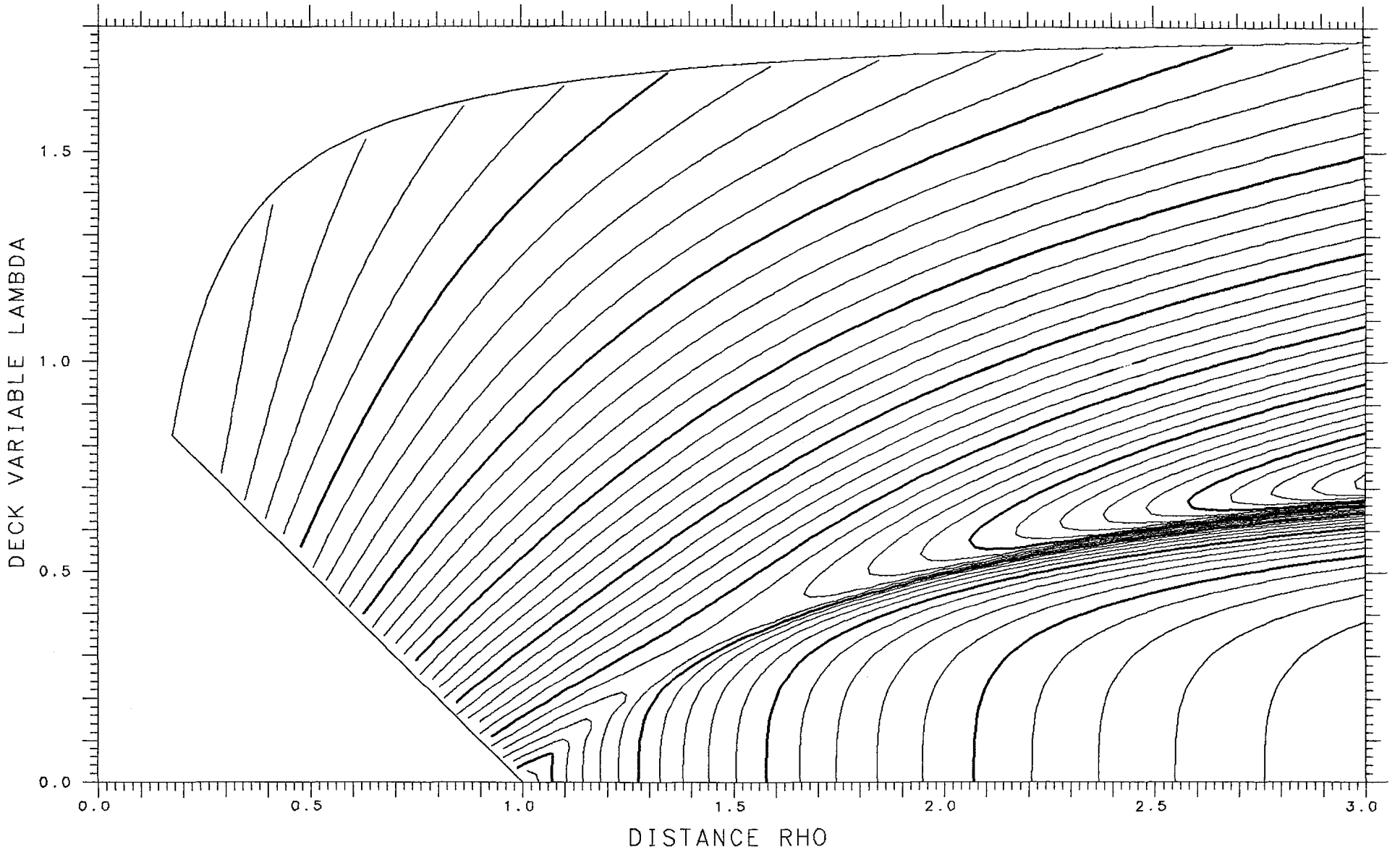

X= .950 ASYMMETRY DELTA= .475 FRACTIONAL= .9569

SPHERES -.03053 TANGENT .06732 LENGTH 10.963 ENERGY 722.20 SPACING .002

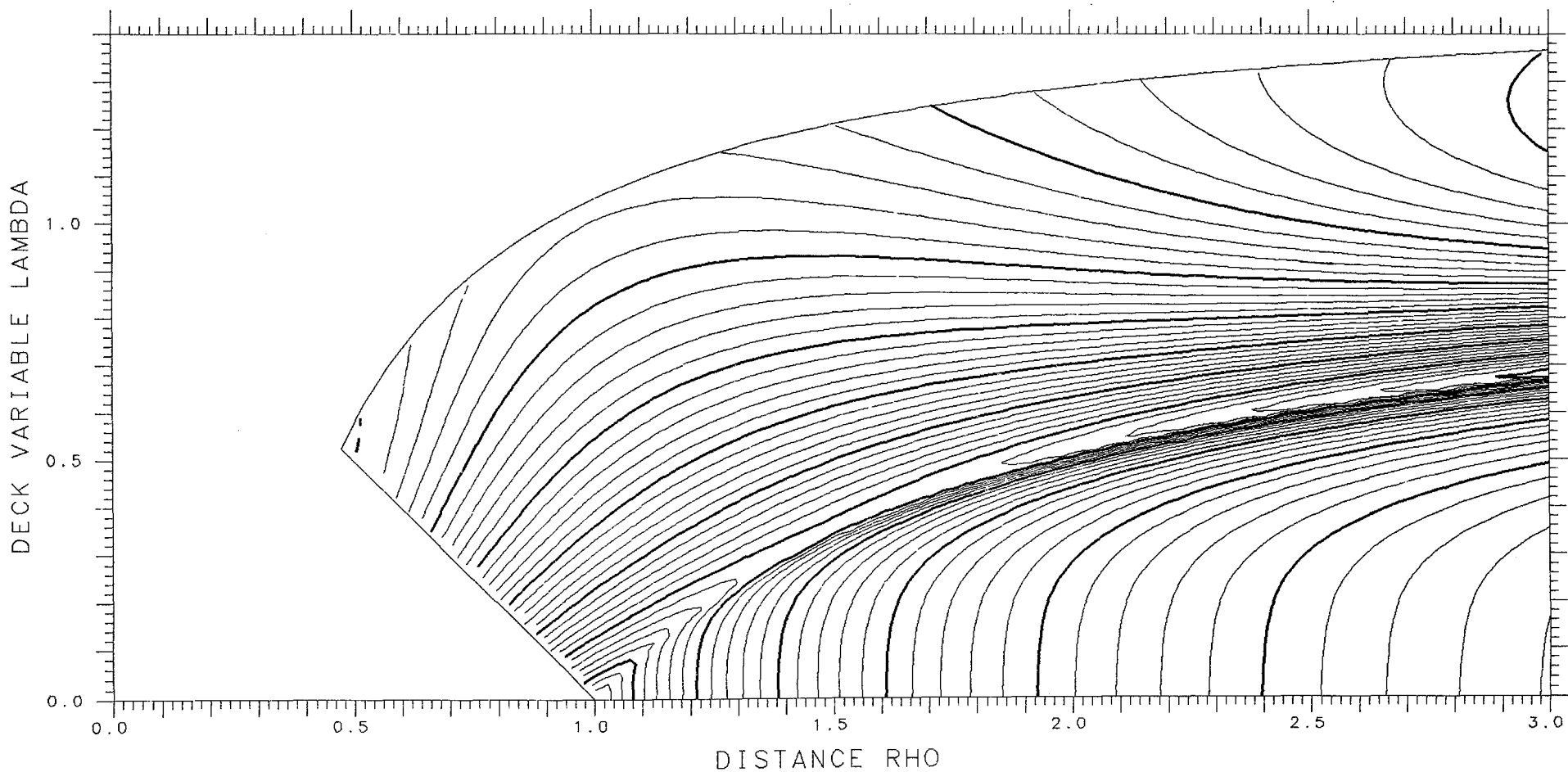

X= .400 ASYMMETRY DELTA= .200 FRACTIONAL= .7714

SPHERES .00242 TANGENT .15623 LENGTH 8.860 ENERGY 388.03 SPACING .005 SADDLE .12983

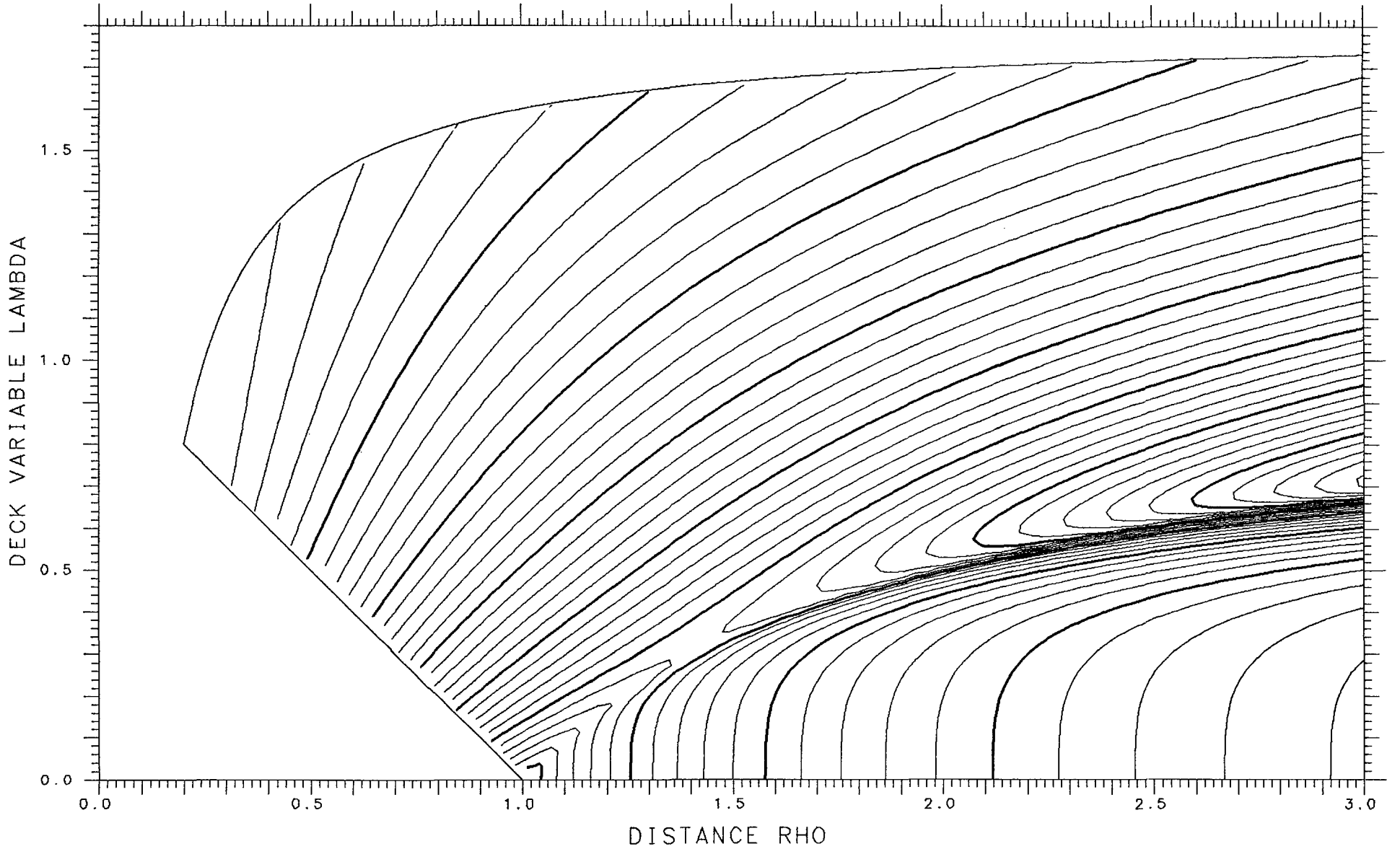

X= .950

ASYMMETRY DELTA= .450

FRACTIONAL= .9483

SPHERES -.04331

TANGENT .07136

LENGTH 11.118

ENERGY 722.20

SPACING .002

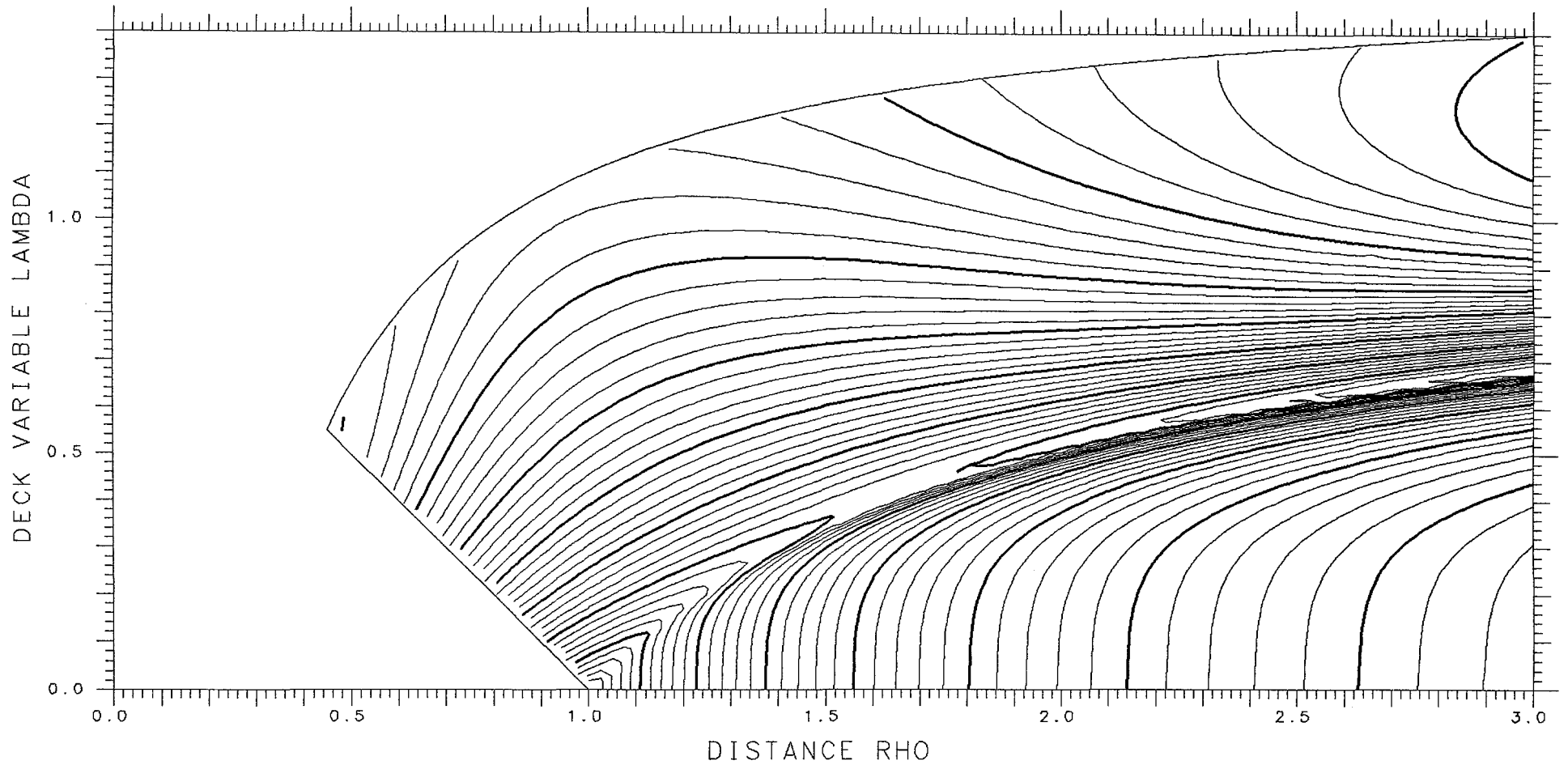

X= .400 ASYMMETRY DELTA= .225 FRACTIONAL= .7979

SPHERES .00947 TANGENT .15143 LENGTH 8.778 ENERGY 388.03 SPACING .005 SADDLE .12786

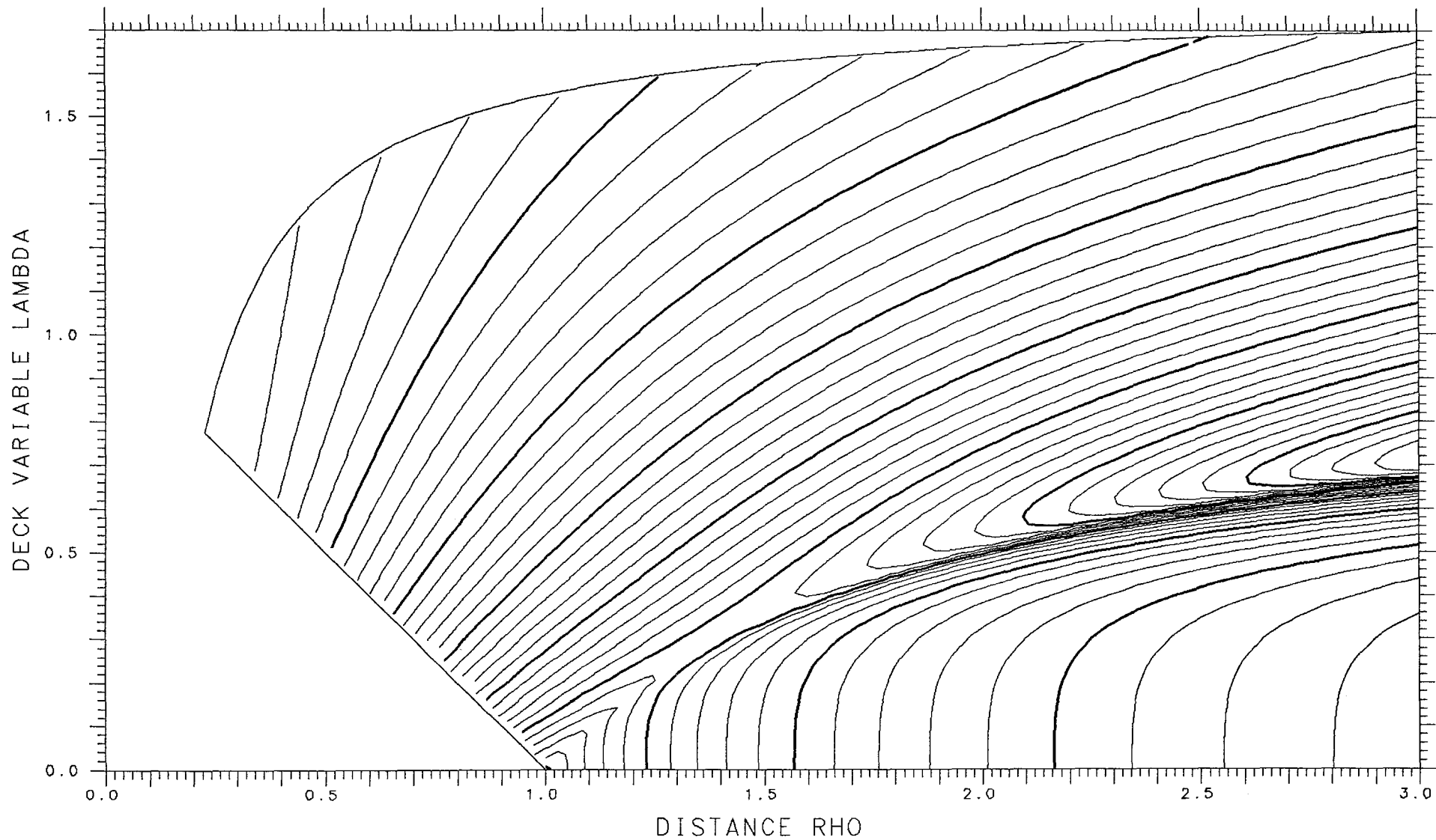

X= .950 ASYMMETRY DELTA= .425 FRACTIONAL= .9384

SPHERES -.05838 TANGENT .07494 LENGTH 11.274 ENERGY 722.20 SPACING .002

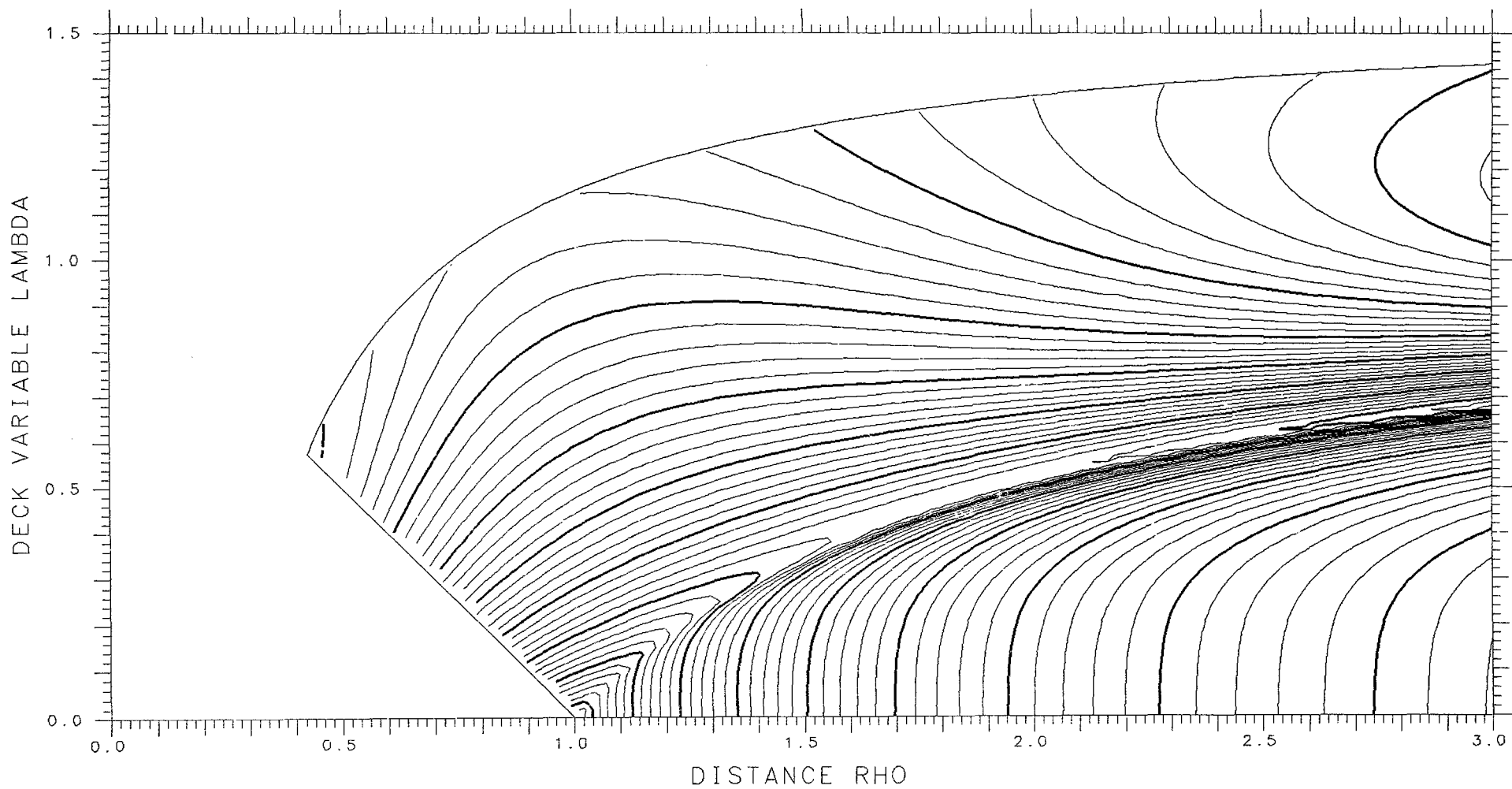

X= .400 ASYMMETRY DELTA= .250 FRACTIONAL= .8224

SPHERES .01614 TANGENT .14607 LENGTH 8.689 ENERGY 388.03 SPACING .005 SADDLE .12531

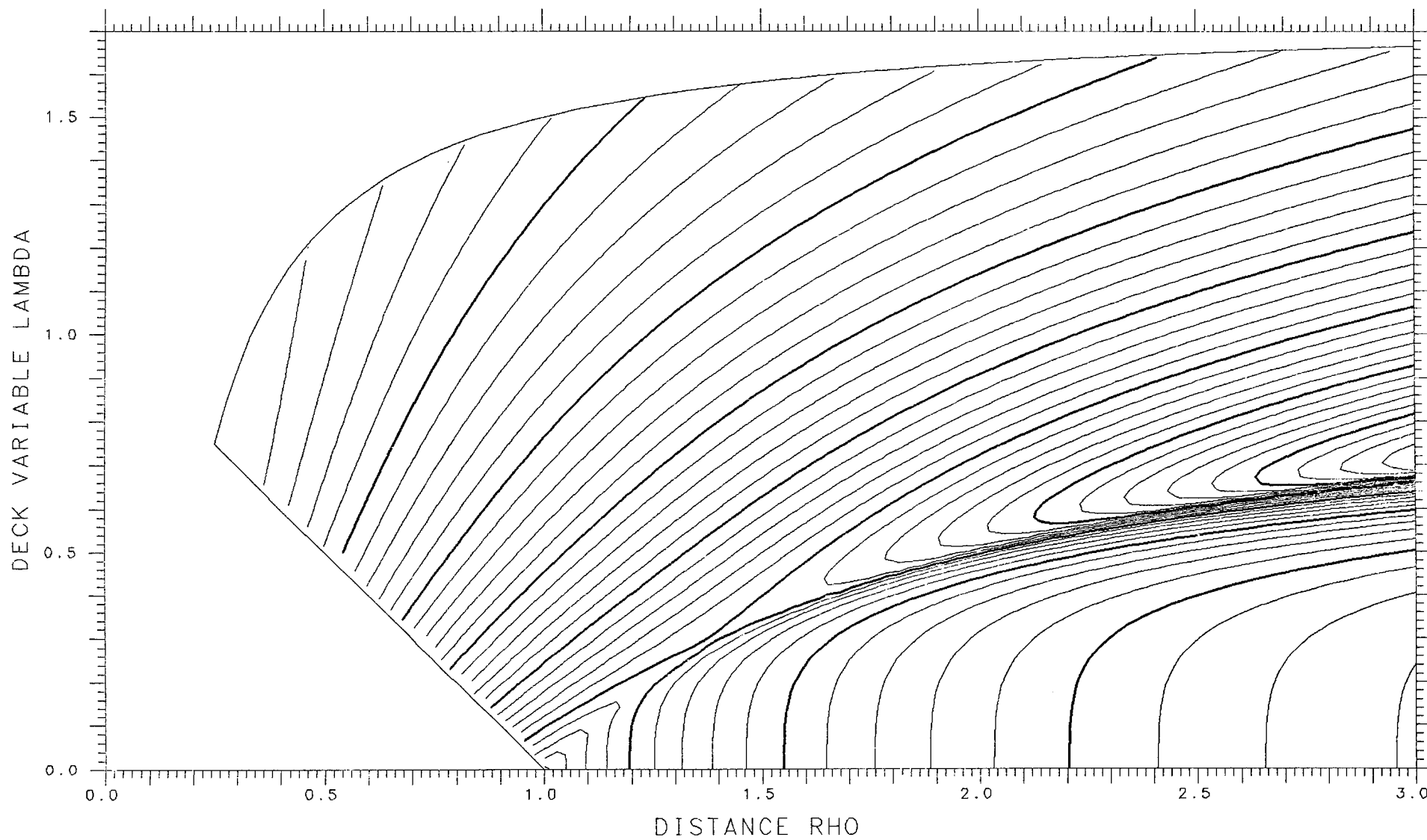

X= .950

ASYMMETRY DELTA= .400

FRACTIONAL= .9270

SPHERES -.07584

TANGENT .07795

LENGTH 11.429

ENERGY 722.20

SPACING .002

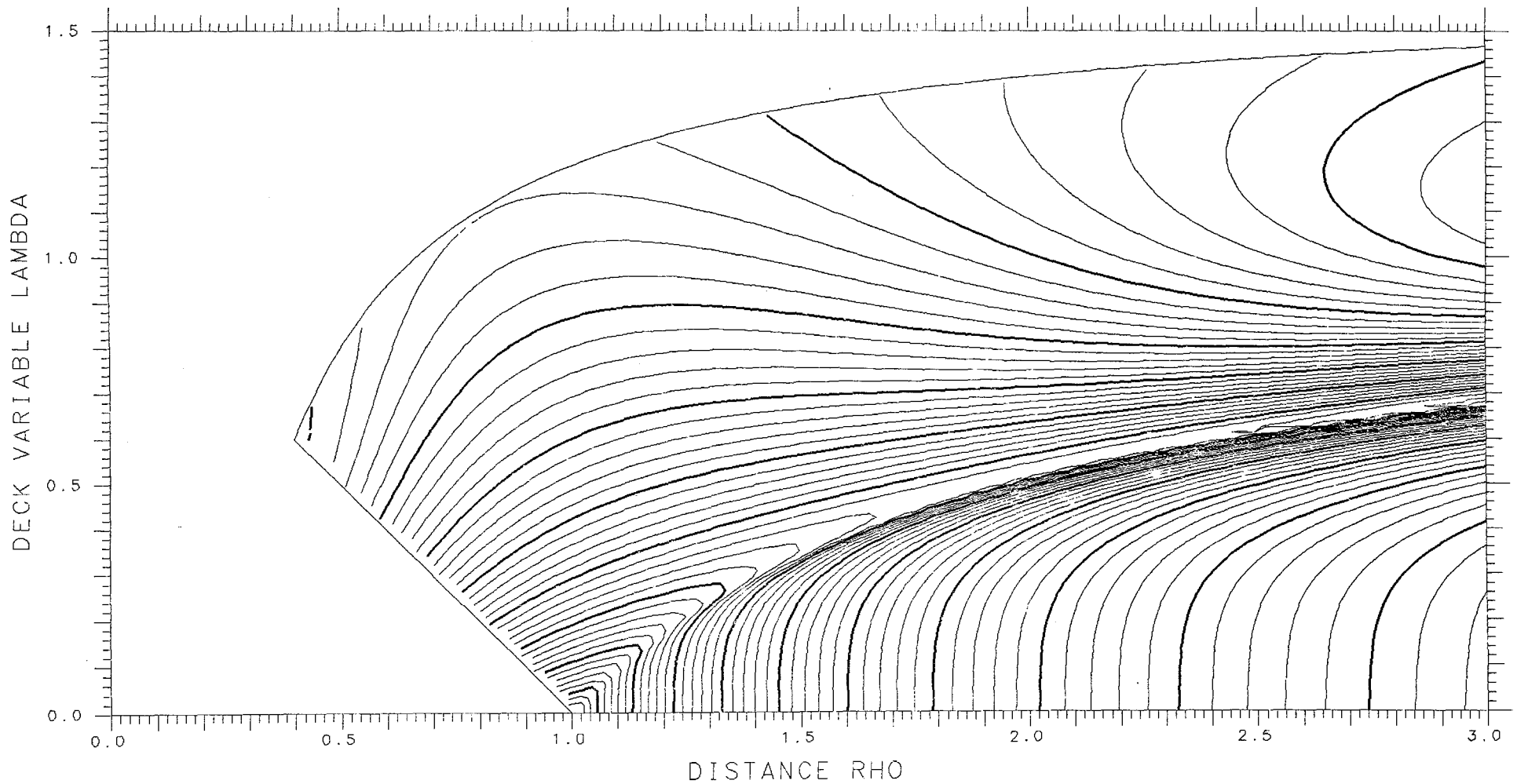

X= .400

ASYMMETRY DELTA= .275

FRACTIONAL= .8447

SPHERES .02225

TANGENT .14021

LENGTH 8.595

ENERGY 388.03

SPACING .005

SADDLE .12217

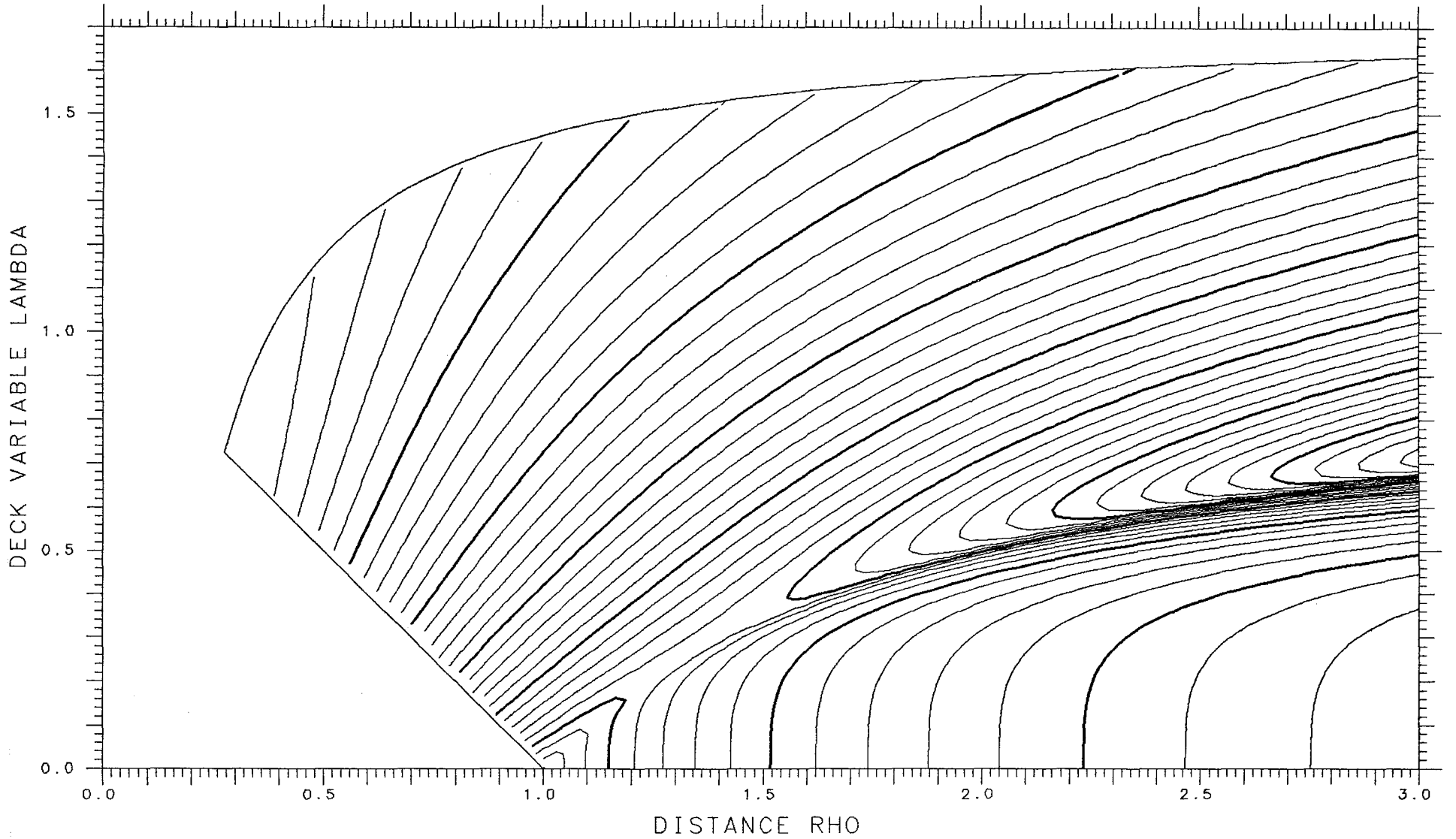

X = .950

ASYMMETRY DELTA = .375

FRACTIONAL = .9141

SPHERES -.09574

TANGENT .08031

LENGTH 11.582

ENERGY 722.20

SPACING .002

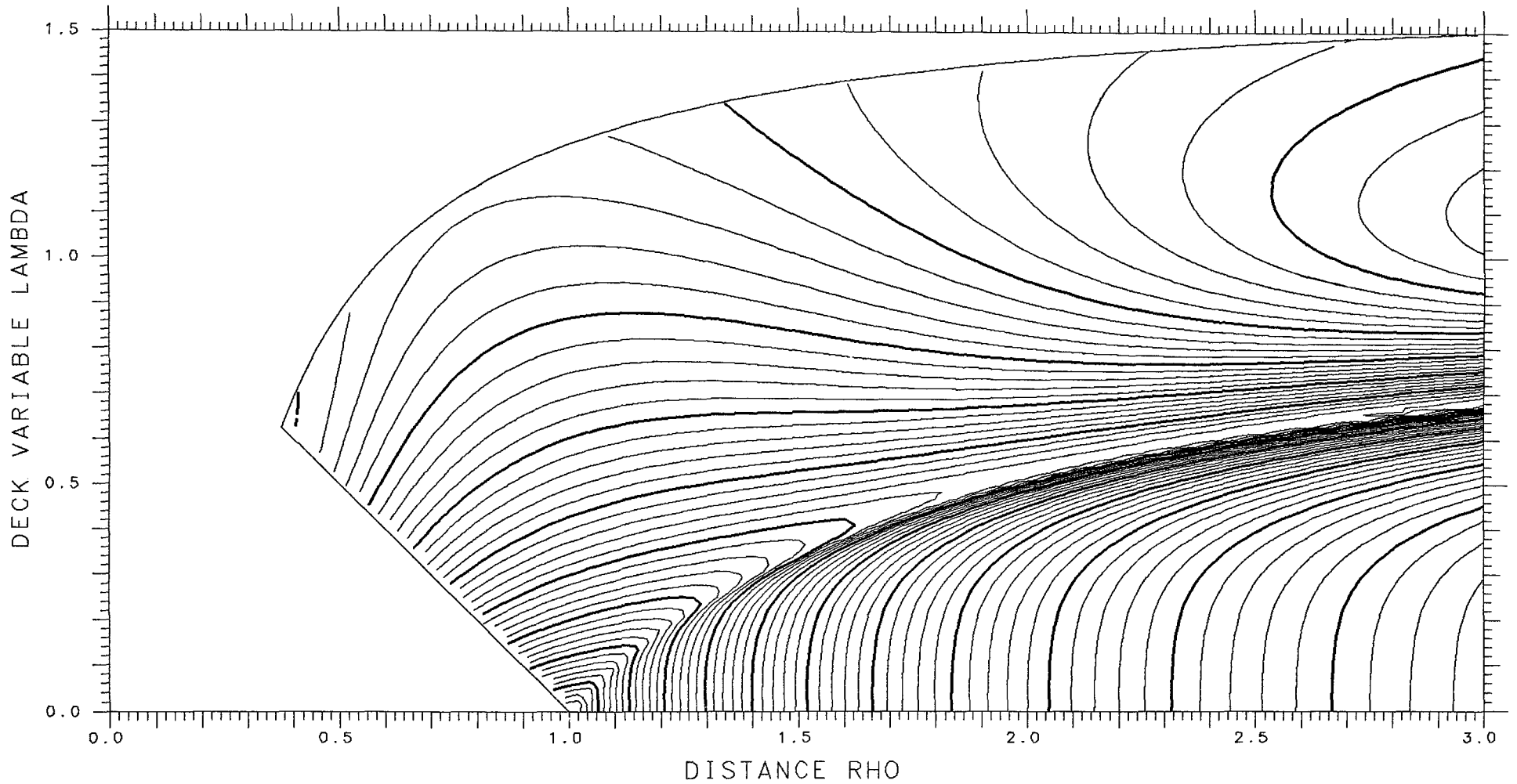

X= .400 ASYMMETRY DELTA= .300 FRACTIONAL= .8650

SPHERES .02764 TANGENT .13389 LENGTH 8.497 ENERGY 388.03 SPACING .005

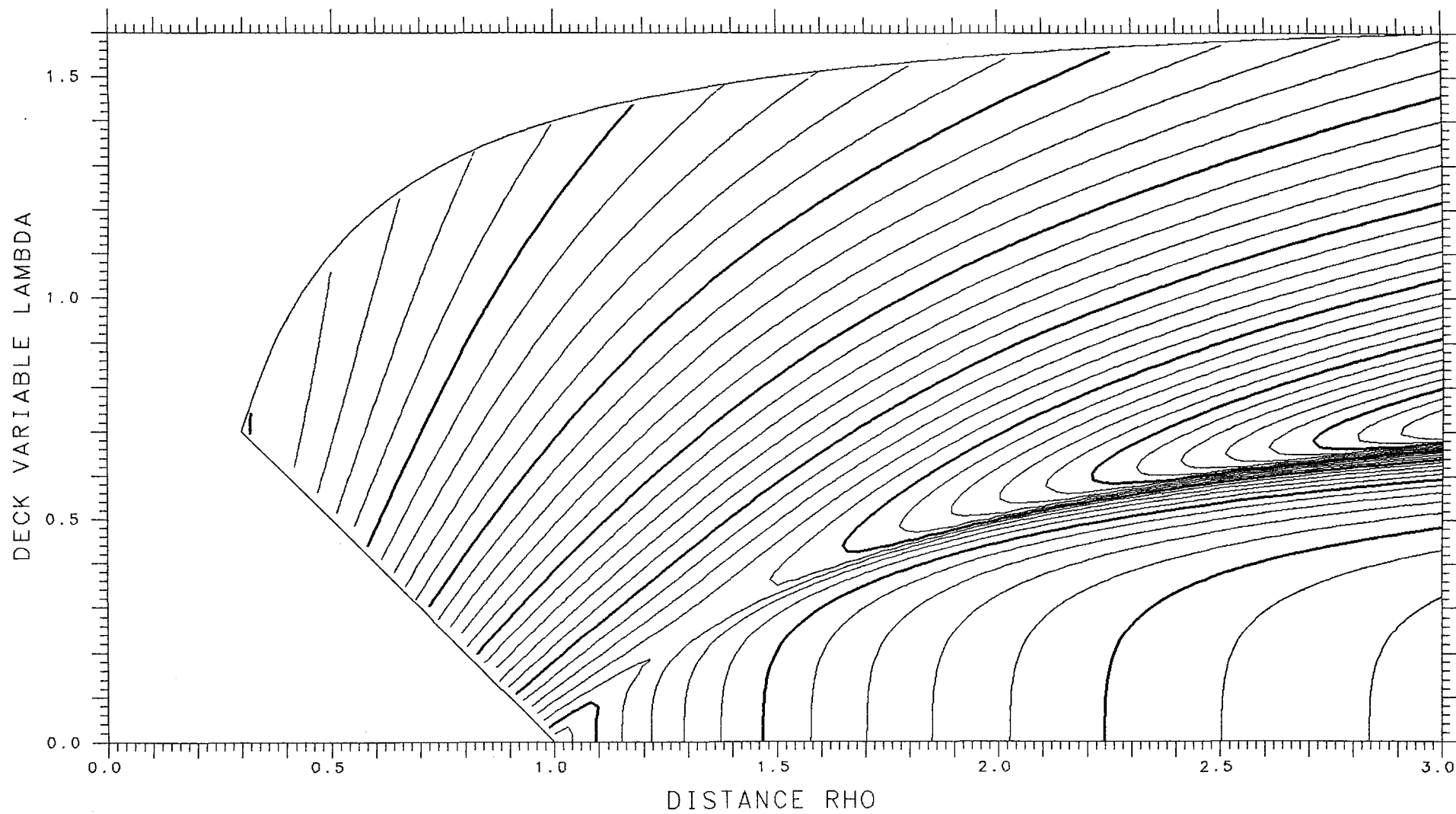

X= .950 ASYMMETRY DELTA= .350 FRACTIONAL= .8996

SPHERES -.11807 TANGENT .08194 LENGTH 11.734 ENERGY 722.20 SPACING .002

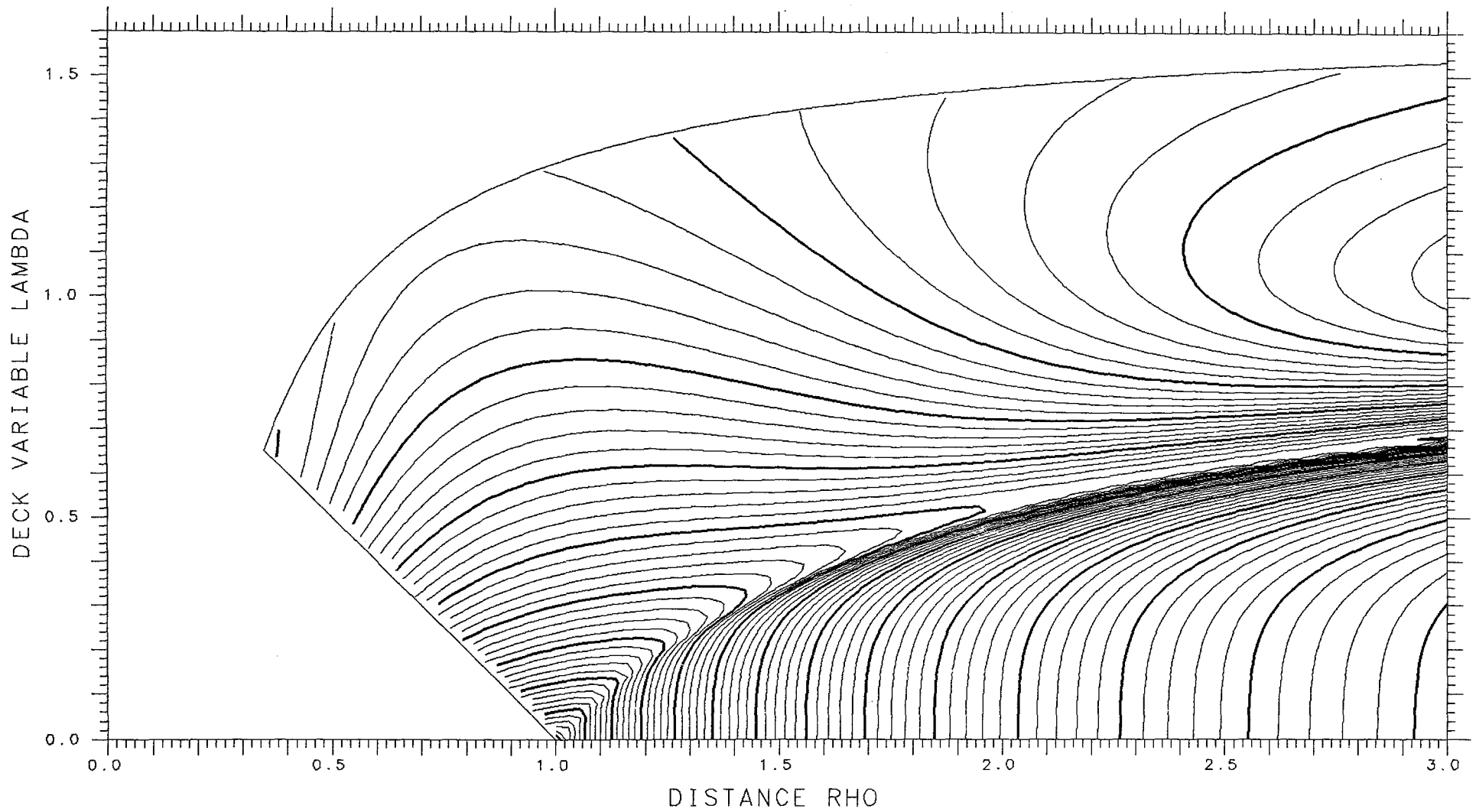

X= .400 ASYMMETRY DELTA= .325 FRACTIONAL= .8832

SPHERES .03222 TANGENT .12718 LENGTH 8.395 ENERGY 388.03 SPACING .005

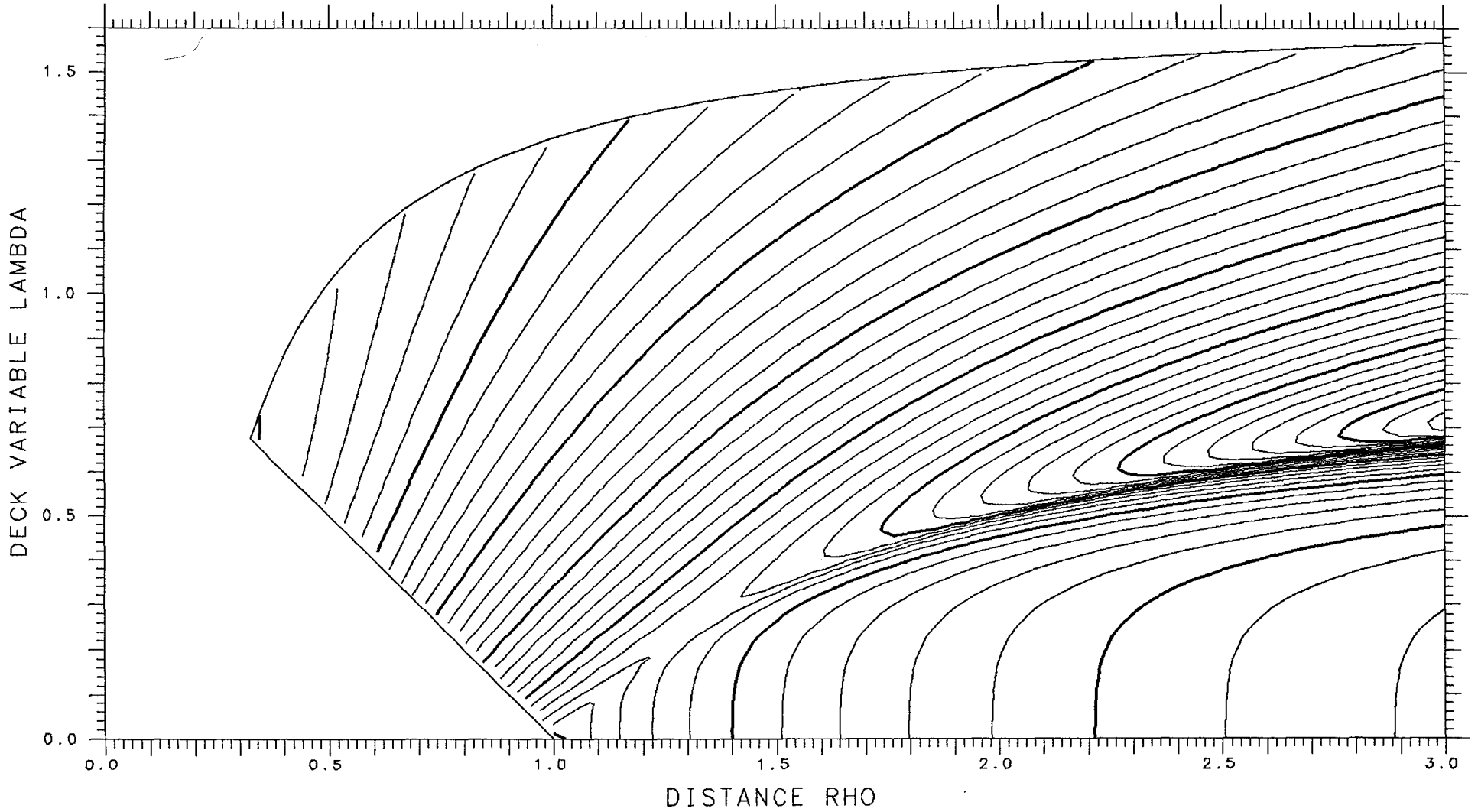

X= .950 ASYMMETRY DELTA= .325 FRACTIONAL= .8832

SPHERES -.14273 TANGENT .08279 LENGTH 11.882 ENERGY 722.20 SPACING .002

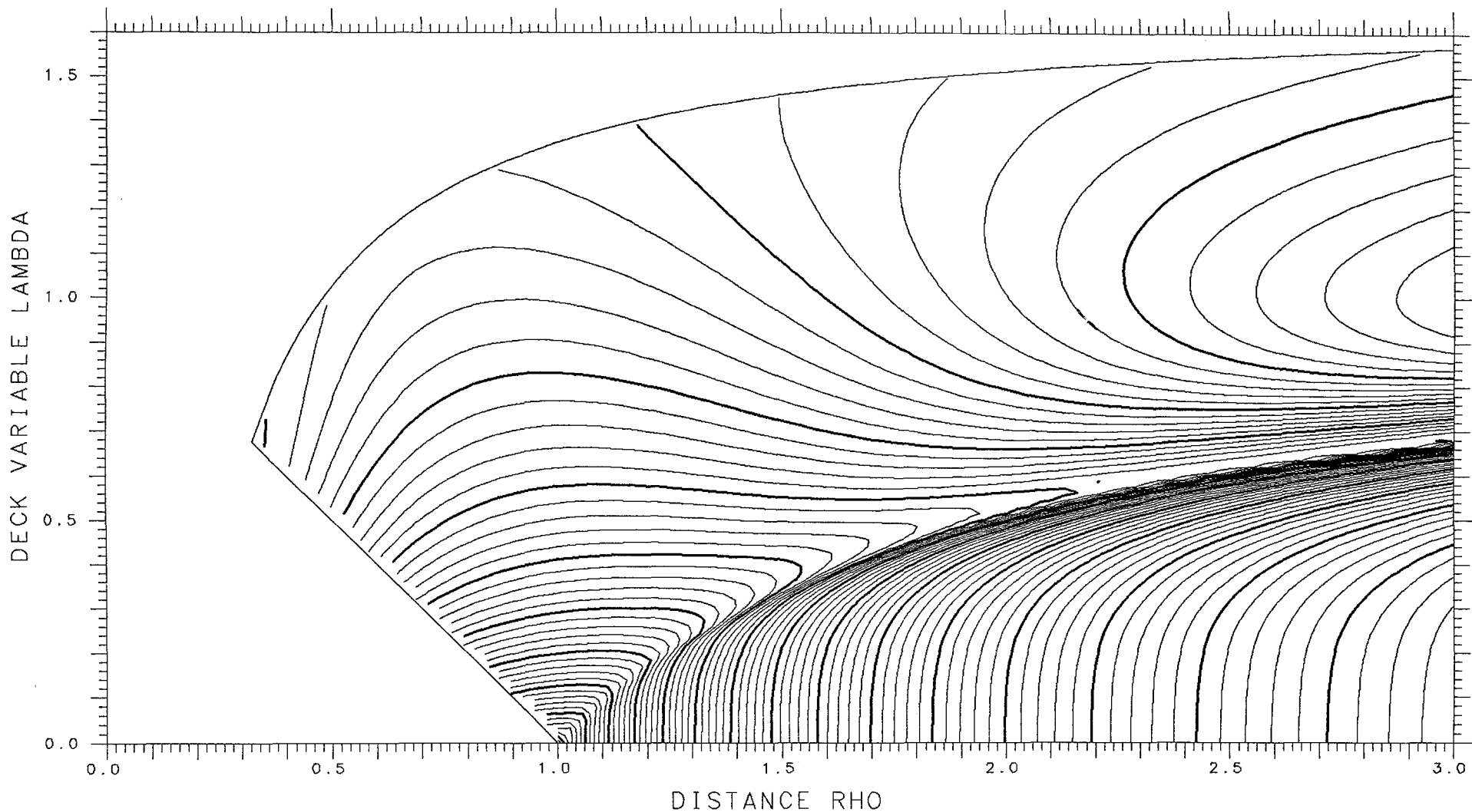

X= .400 ASYMMETRY DELTA= .350 FRACTIONAL= .8996

SPHERES .03592 TANGENT .12014 LENGTH 8.290 ENERGY 388.03 SPACING .005

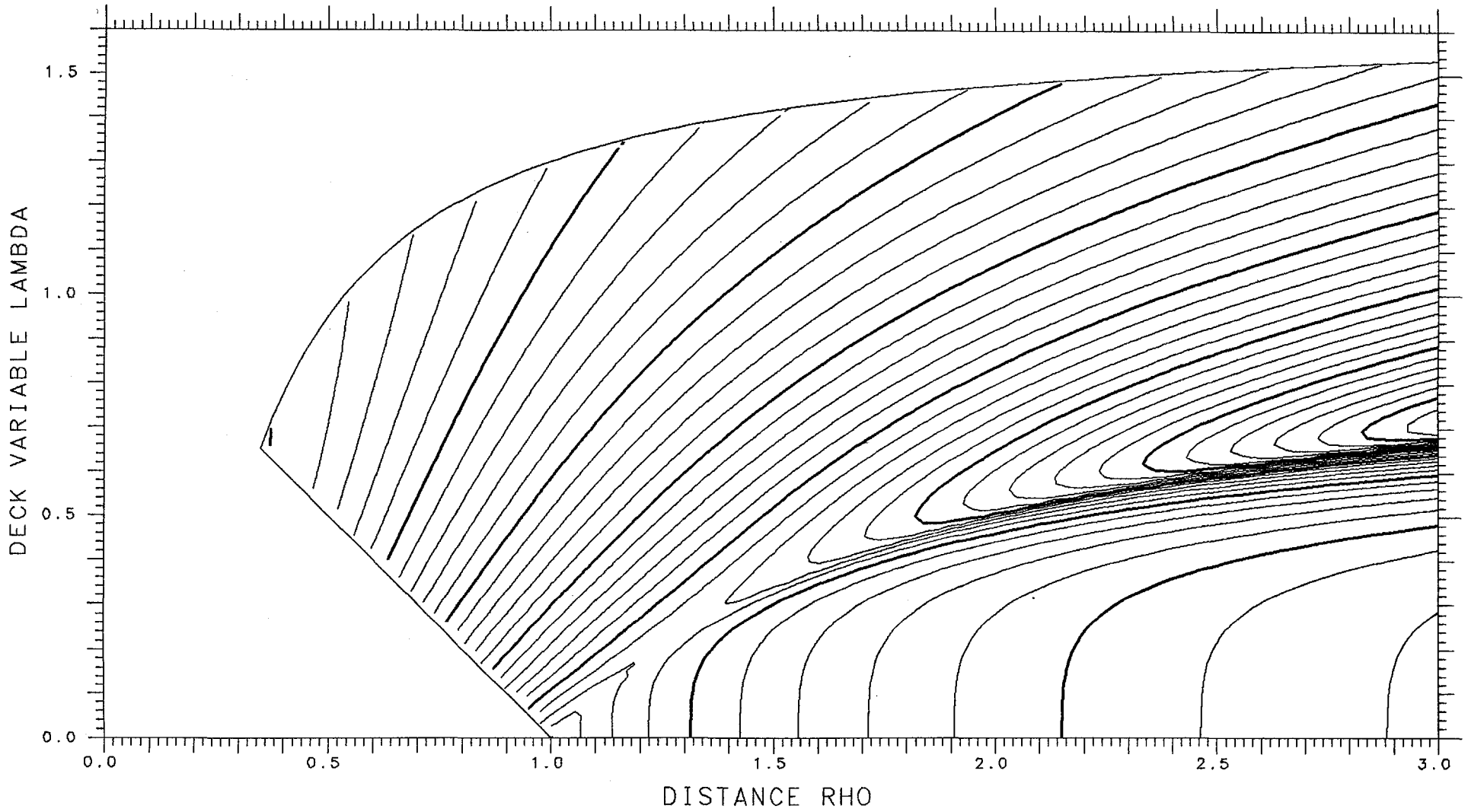

X= .950 ASYMMETRY DELTA= .300 FRACTIONAL= .8650

SPHERES -.16951 TANGENT .08282 LENGTH 12.027 ENERGY 722.20 SPACING .002

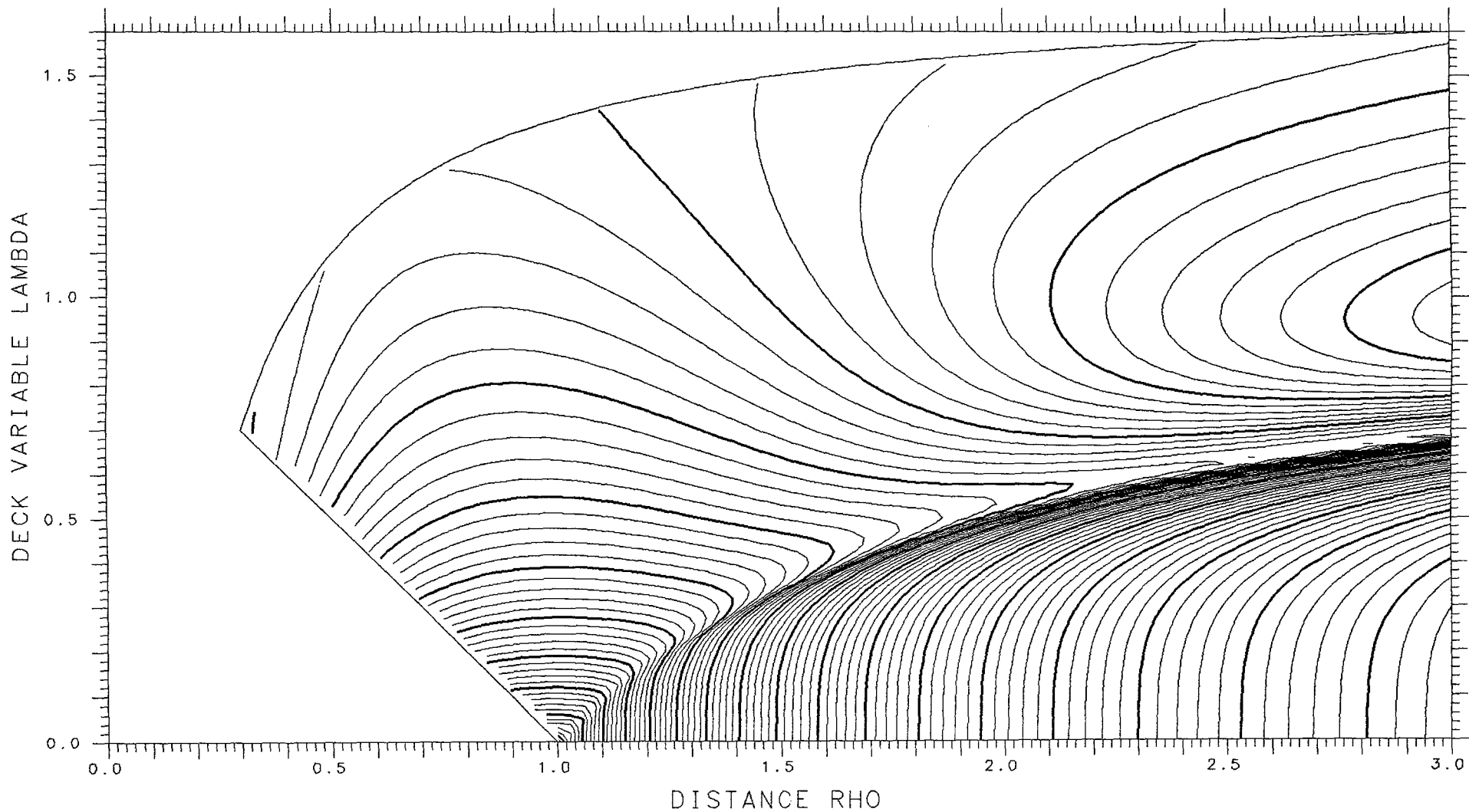

X= .400 ASYMMETRY DELTA= .375 FRACTIONAL= .9141

SPHERES .03873 TANGENT .11286 LENGTH 8.183 ENERGY 388.03 SPACING .005

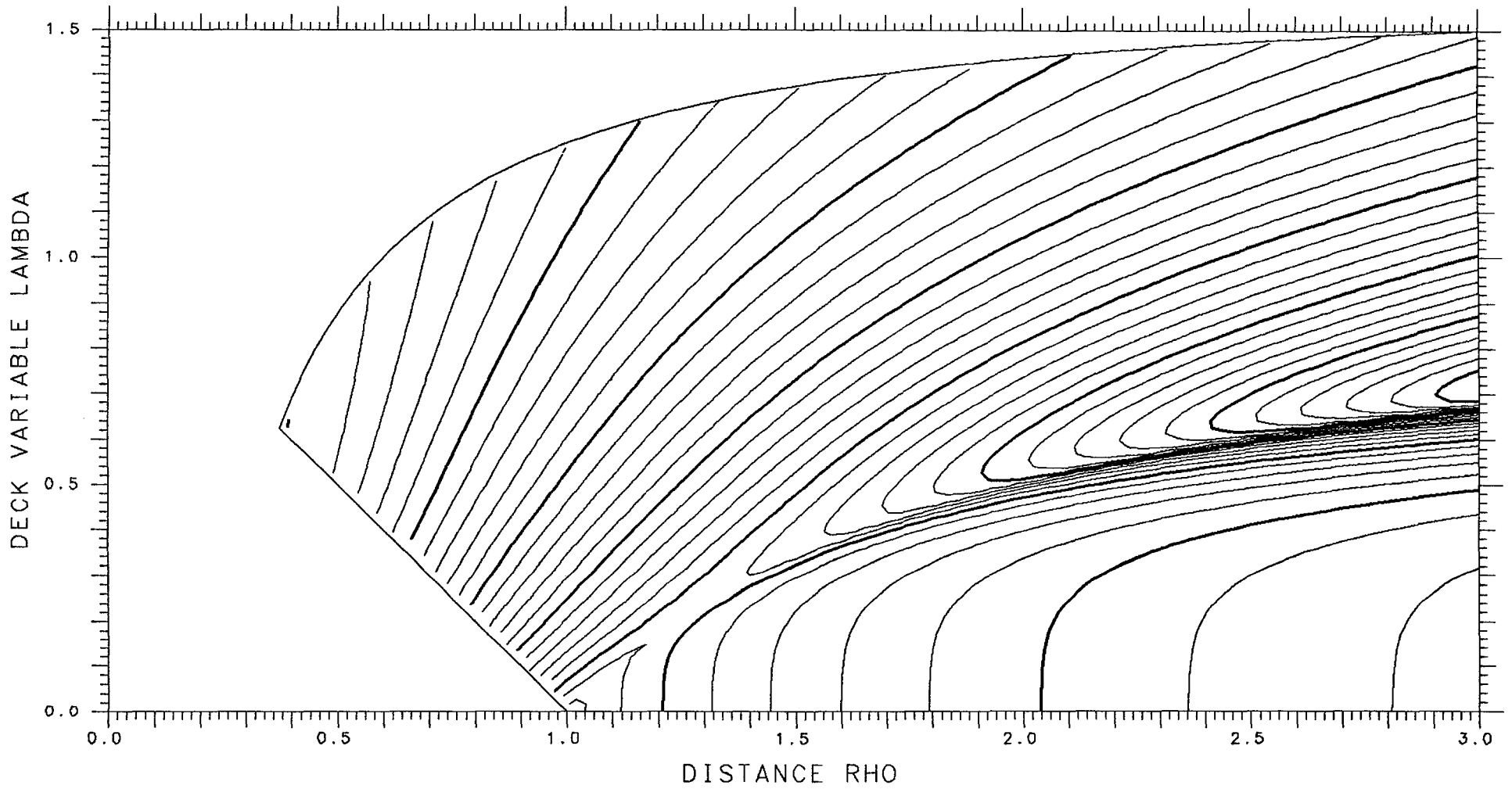

X= .950 ASYMMETRY DELTA= .275 FRACTIONAL= .8447

SPHERES -.19811 TANGENT .08205 LENGTH 12.166 ENERGY 722.20 SPACING .002

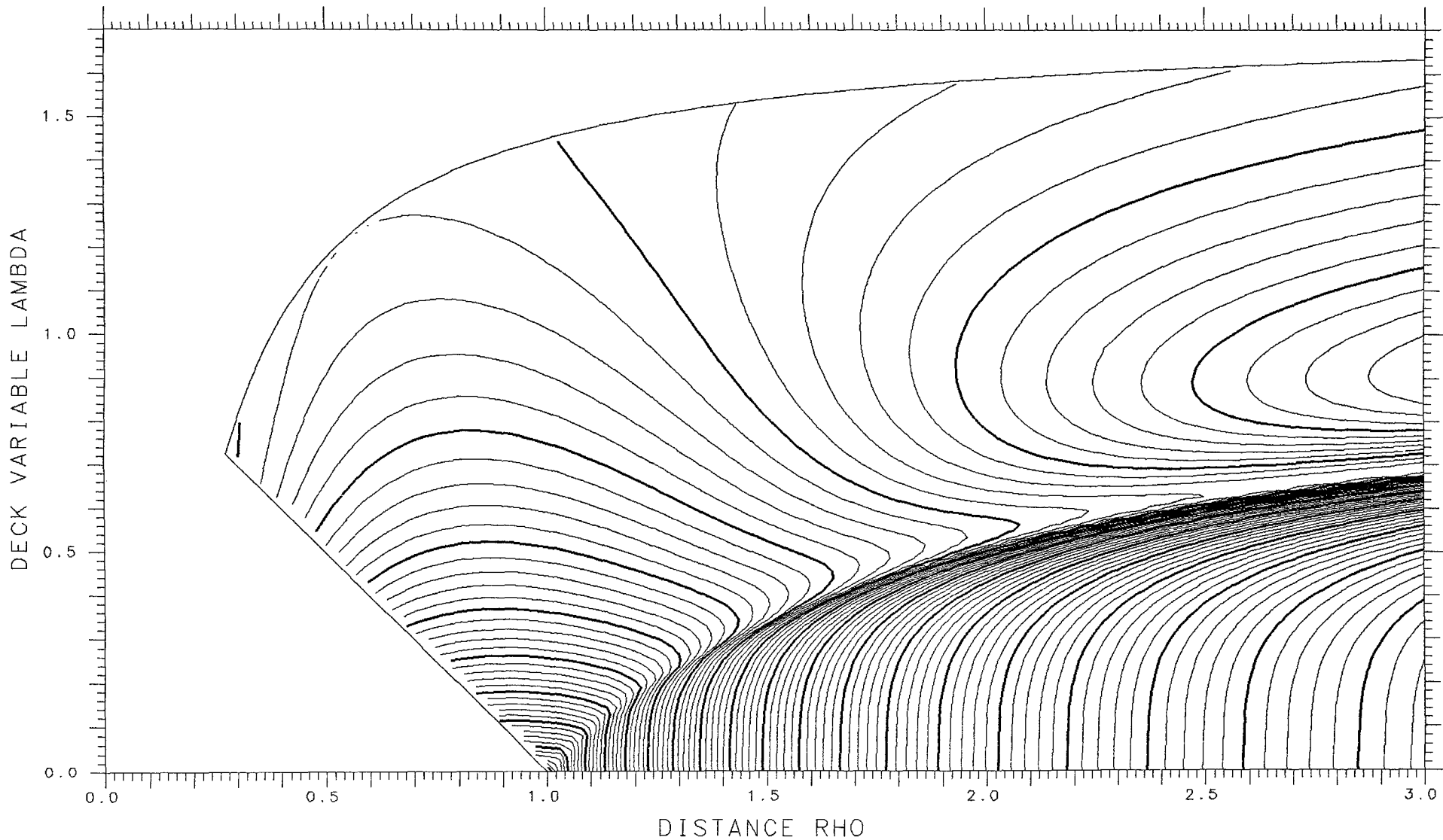

X= .400 ASYMMETRY DELTA= .400 FRACTIONAL= .9270

SPHERES .04065 TANGENT .10540 LENGTH 8.074 ENERGY 388.03 SPACING .005

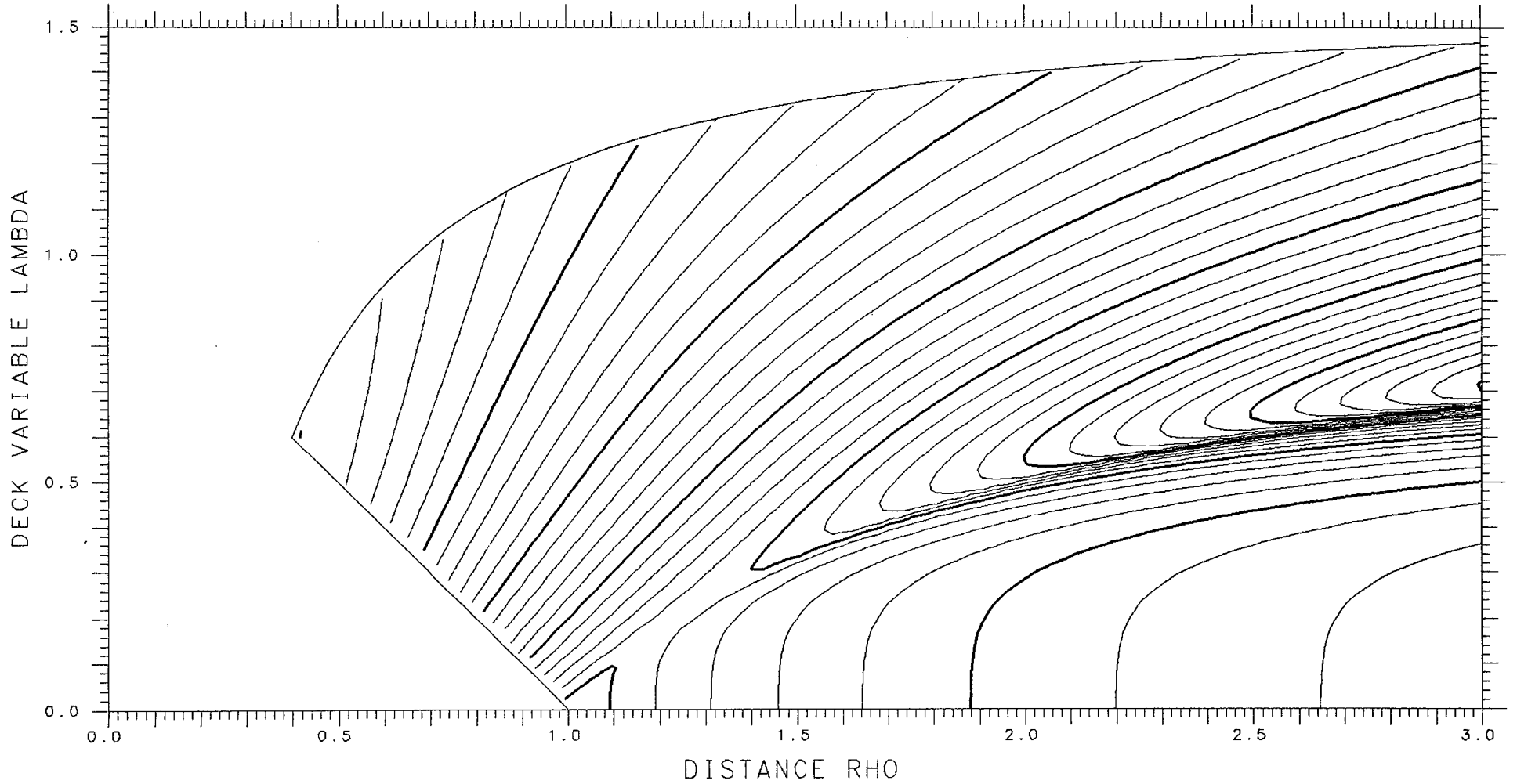

X = .950

ASYMMETRY DELTA = .250

FRACTIONAL = .8224

SPHERES = .22809

TANGENT .08050

LENGTH 12.299

ENERGY 722.20

SPACING .002

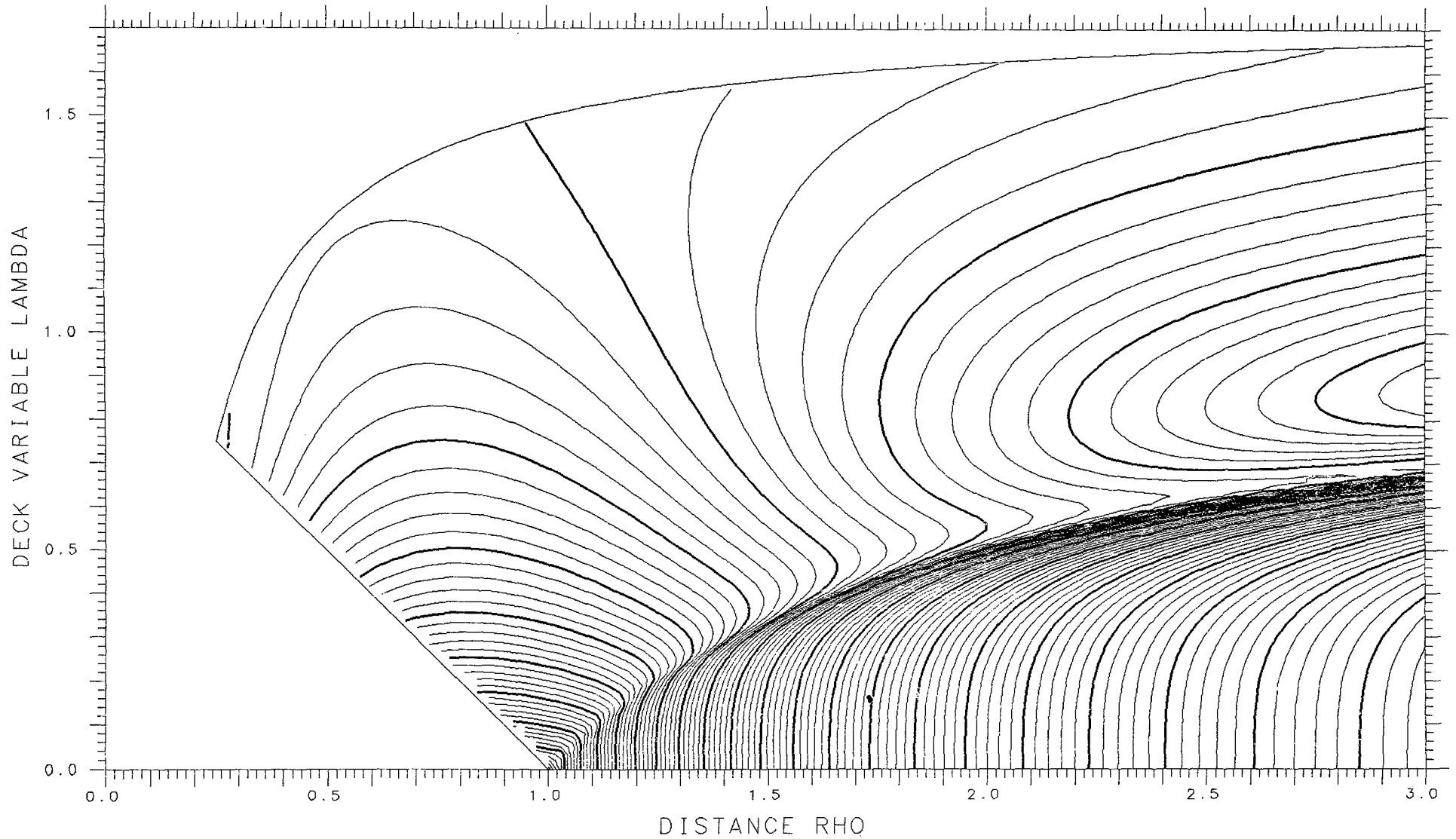

X= .400 ASYMMETRY DELTA= .425 FRACTIONAL= .9384

SPHERES .04172 TANGENT .09786 LENGTH 7.965 ENERGY 388.03 SPACING .005

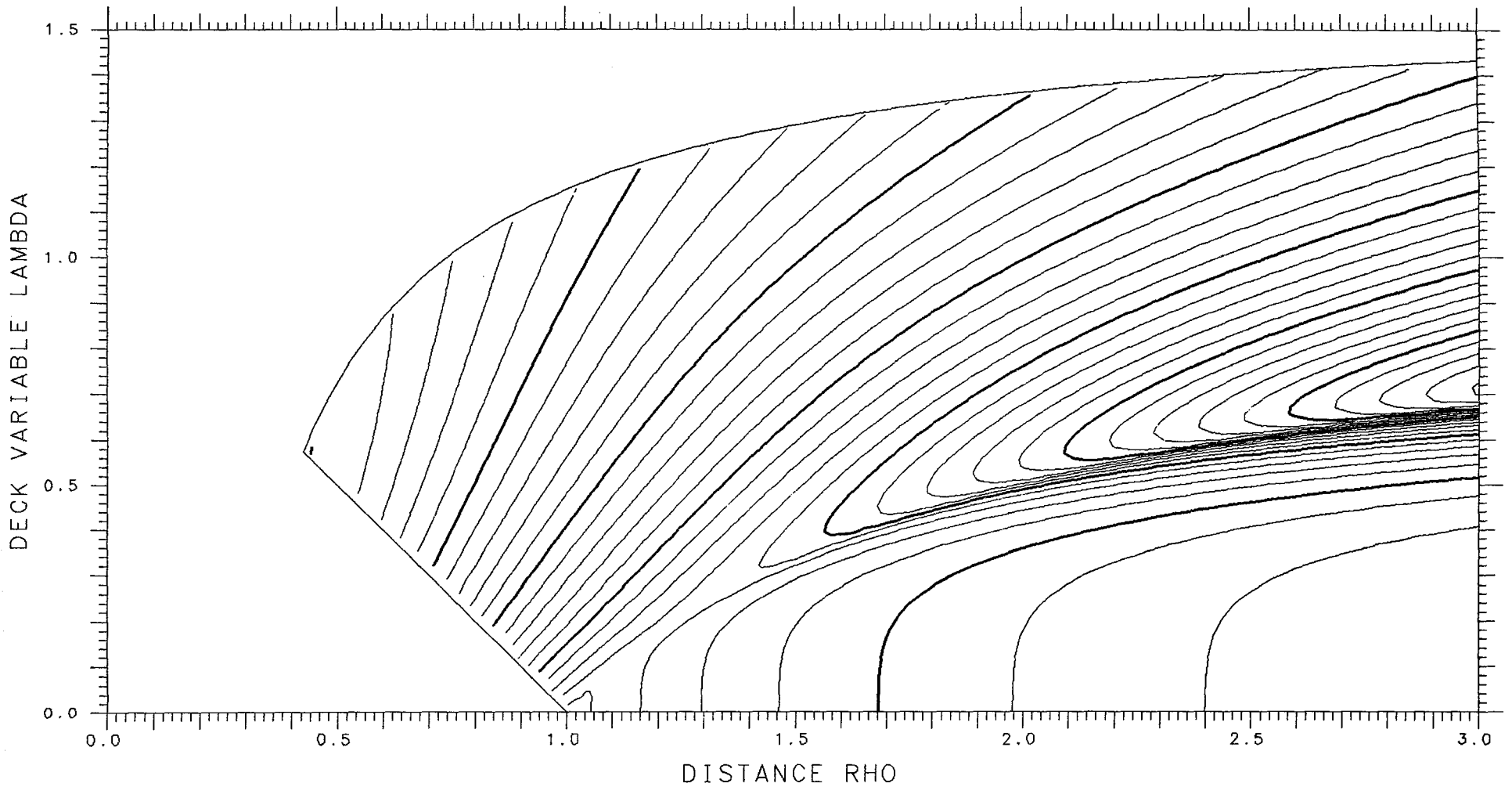

X= .950 ASYMMETRY DELTA= .225 FRACTIONAL= .7979

SPHERES -.25888 TANGENT .07827 LENGTH 12.425 ENERGY 722.20 SPACING .002

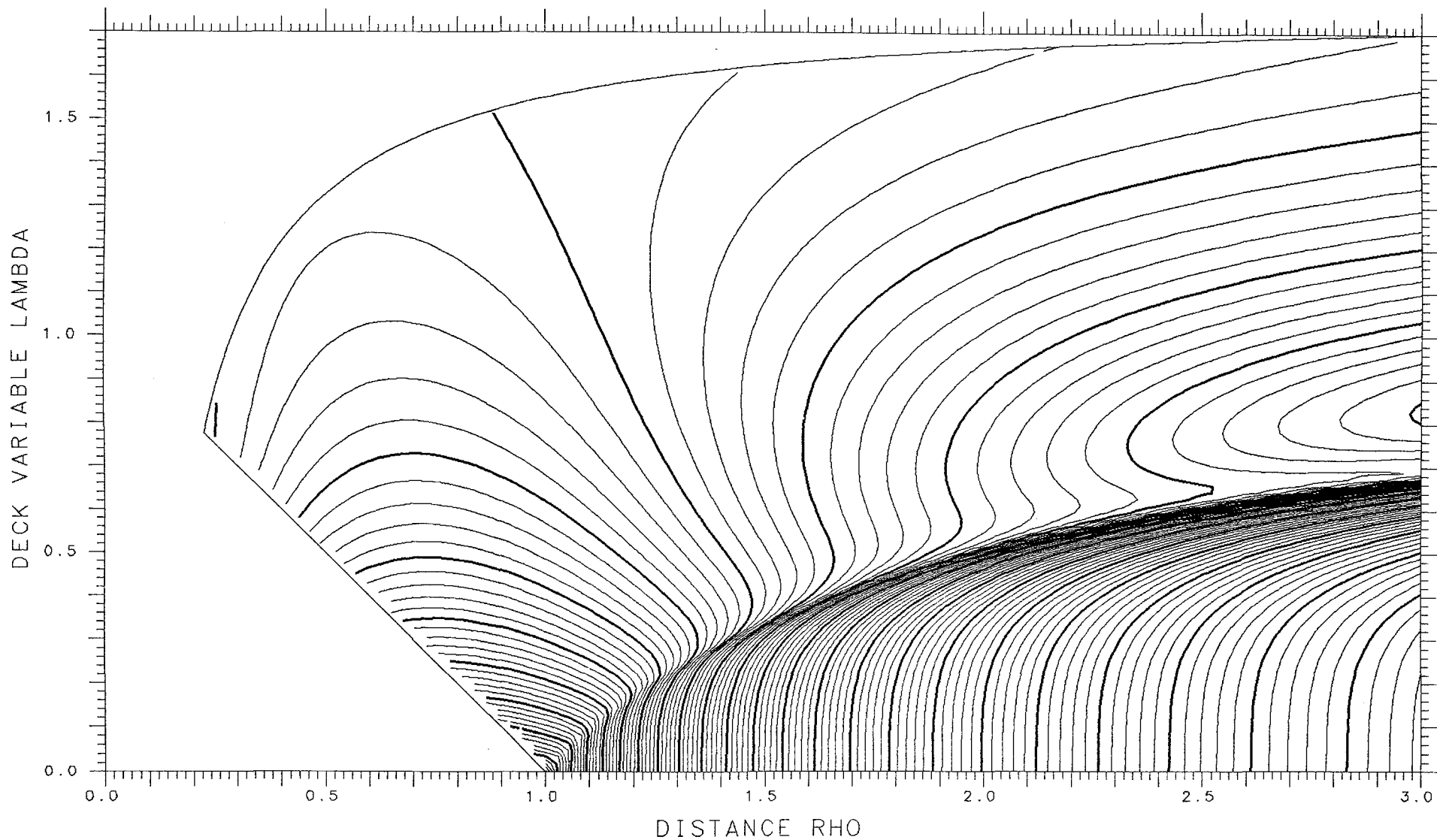

X= .400 ASYMMETRY DELTA= .450 FRACTIONAL= .9483

SPHERES .04201 TANGENT .09029 LENGTH 7.855 ENERGY 388.03 SPACING .005

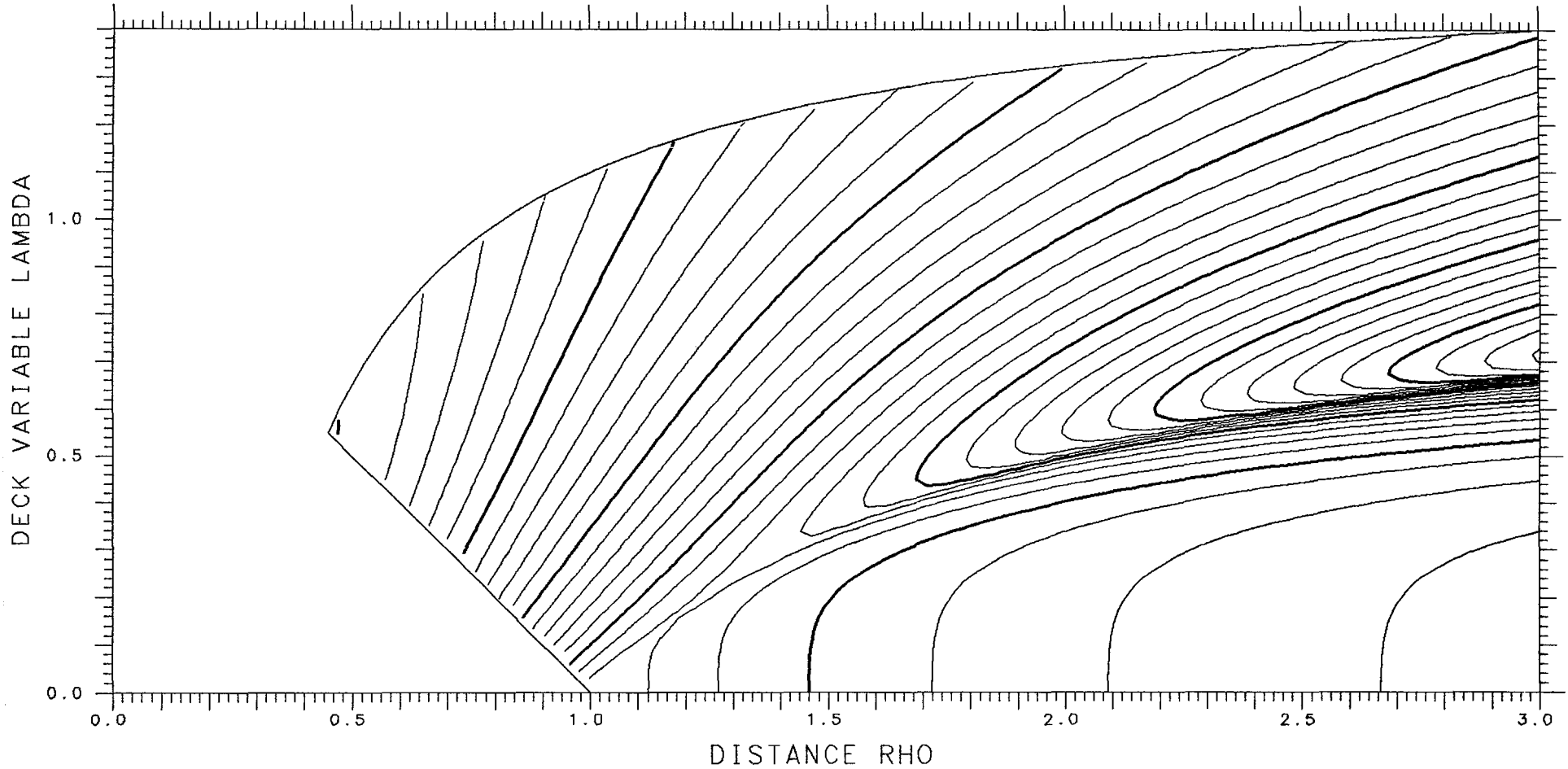

X = .950

ASYMMETRY DELTA = .200

FRACTIONAL = .7714

SPHERES = .28982

TANGENT = .07547

LENGTH 12.541

ENERGY 722.20

SPACING .002

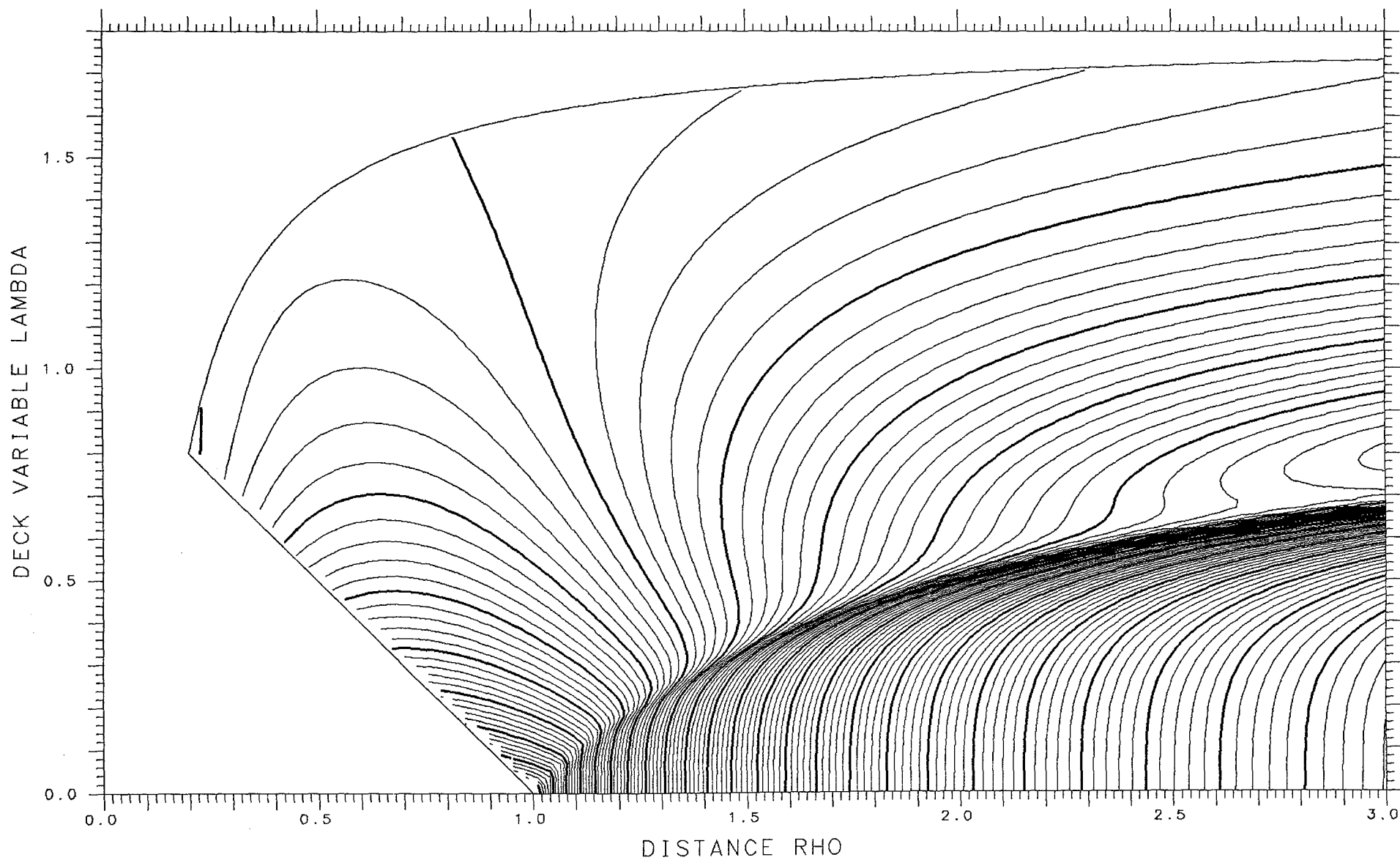

X= .400 ASYMMETRY DELTA= .475 FRACTIONAL= .9569

SPHERES .04159 TANGENT .08279 LENGTH 7.745 ENERGY 328.03 SPACING .005

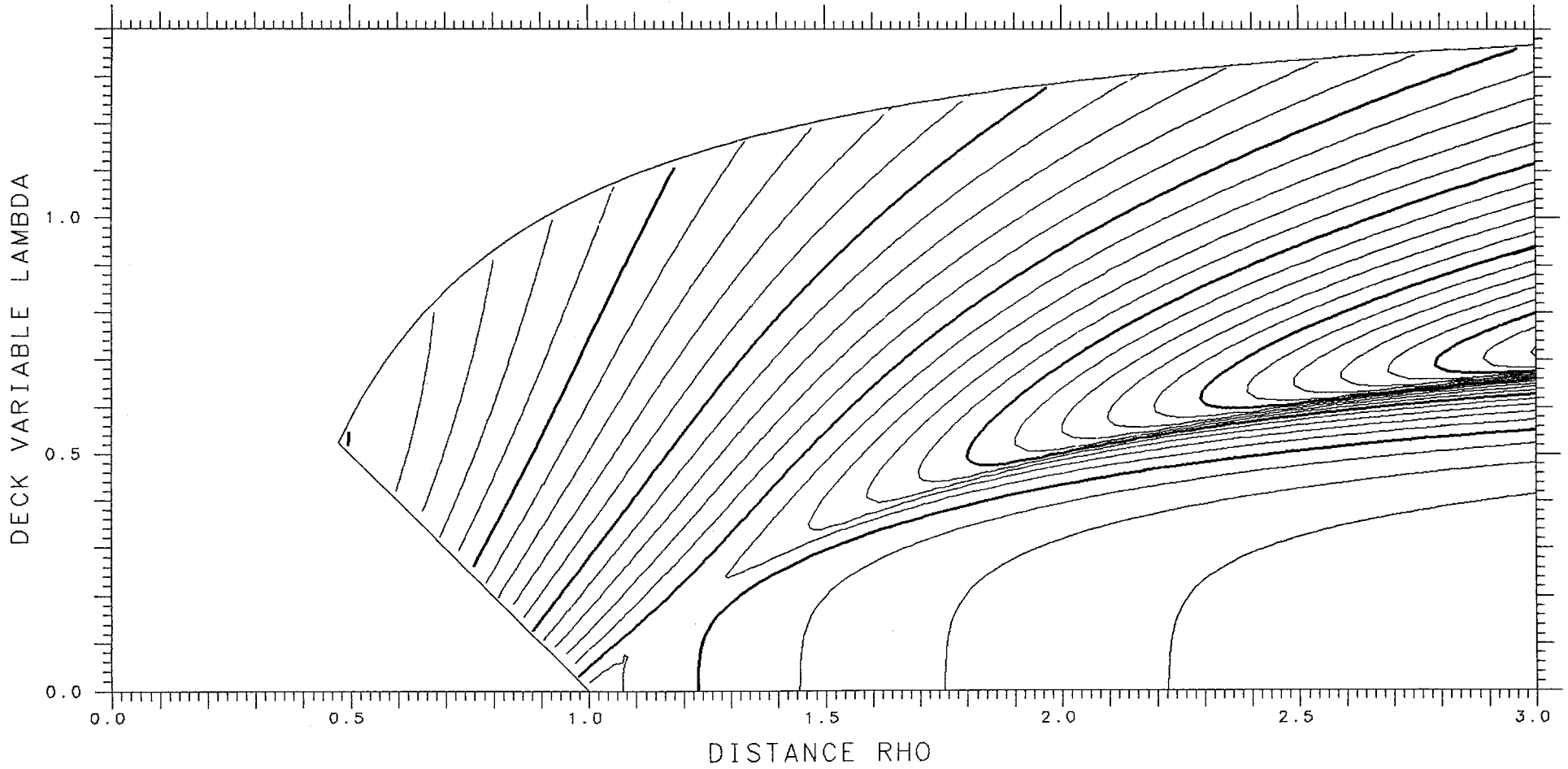

X= .950

ASYMMETRY DELTA= .175

FRACTIONAL= .7429

SPHERES -.32012

TANGENT .07226

LENGTH 12.648

ENERGY 722.20

SPACING .002

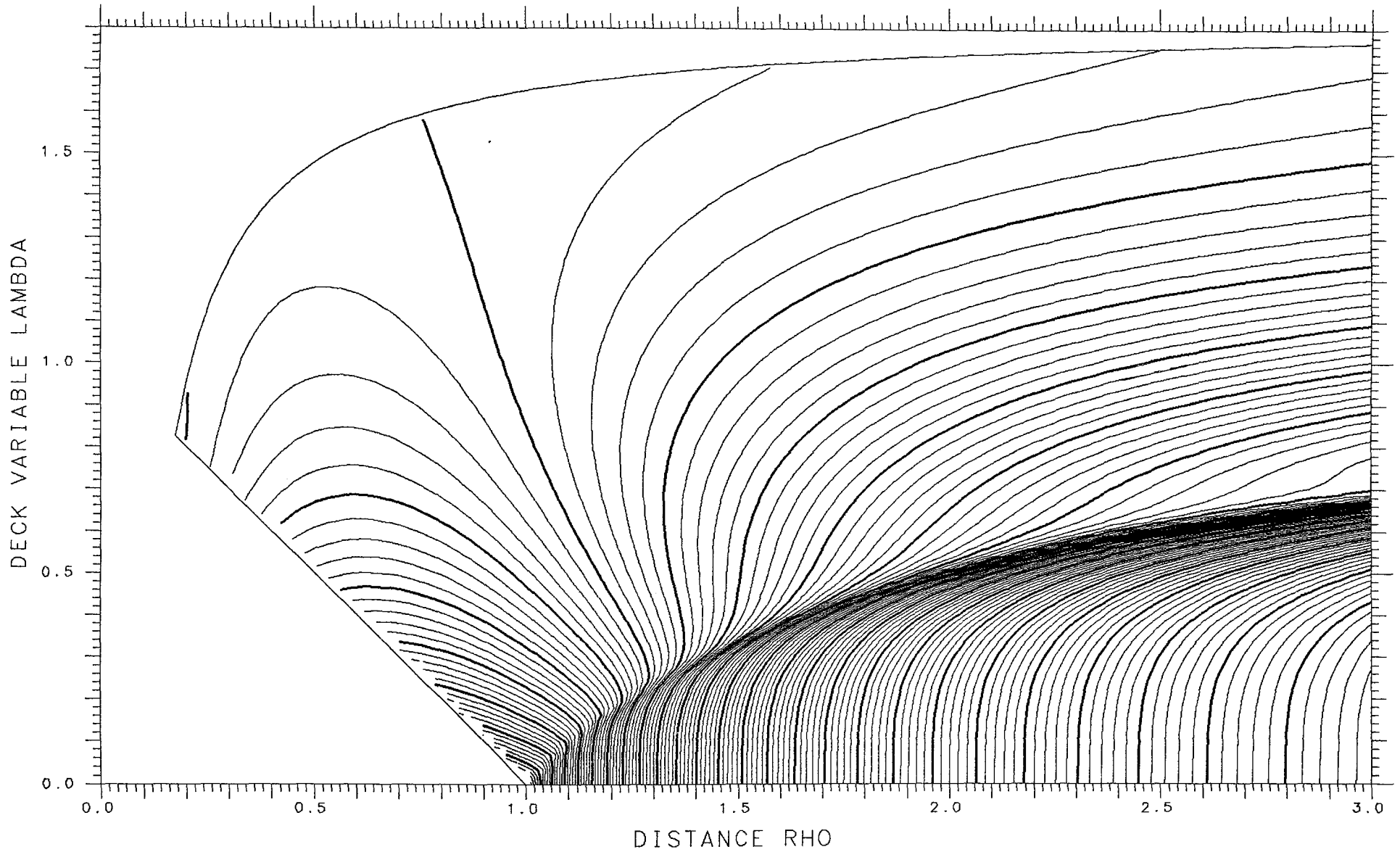

X= .400 ASYMMETRY DELTA= .500 FRACTIONAL= .9643

SPHERES .04054 TANGENT .07540 LENGTH 7.635 ENERGY 388.03 SPACING .005

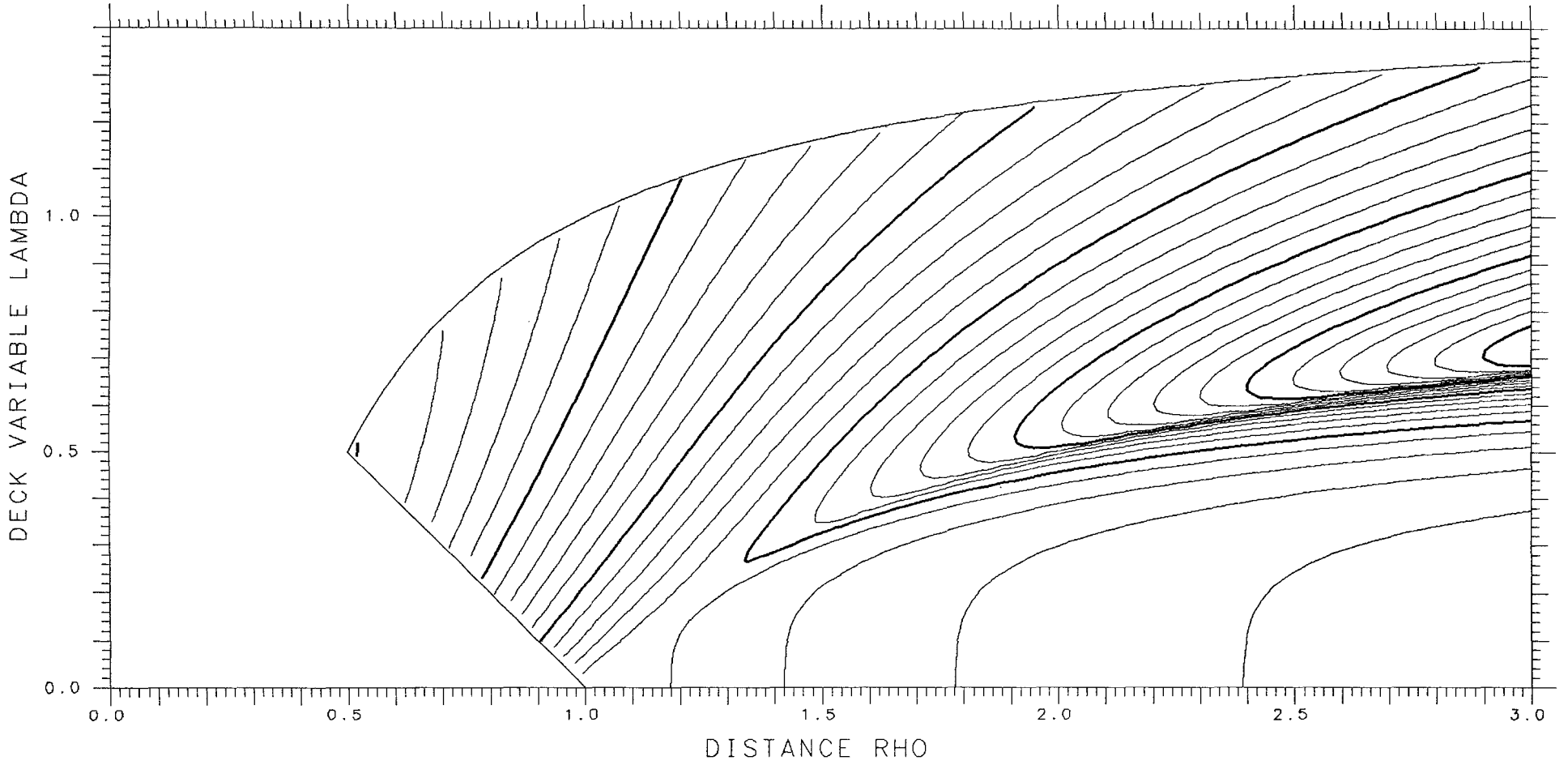

X= .950 ASYMMETRY DELTA= .150 FRACTIONAL= .7124
SPHERES - .34892 TANGENT .06884 LENGTH 12.744 ENERGY 722.20 SPACING .002

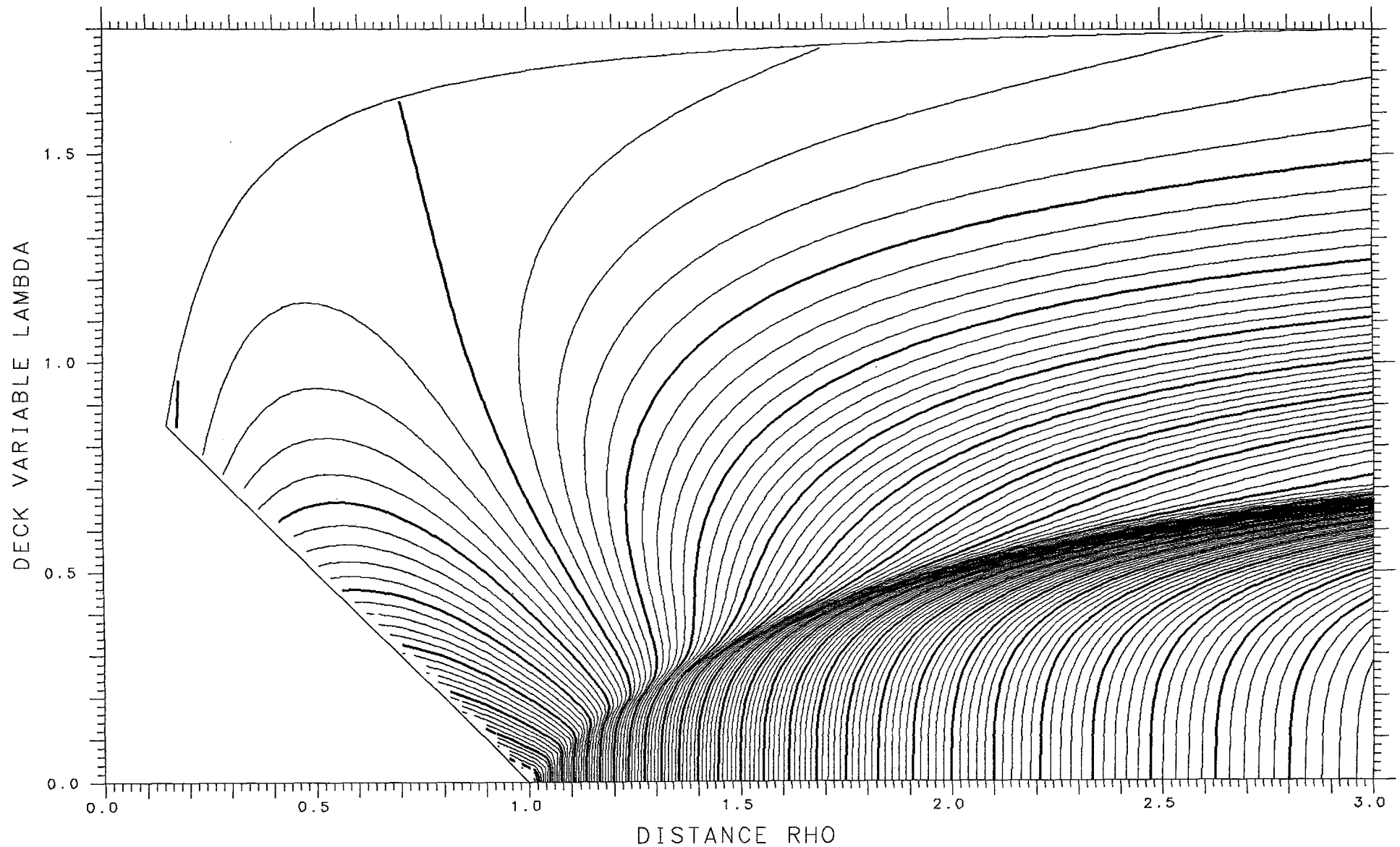

X= .450 ASYMMETRY DELTA=0. FRACTIONAL= .5000

SPHERES -.07311 TANGENT .16312 LENGTH 9.645 ENERGY 423.38 SPACING .005 SADDLE .11520

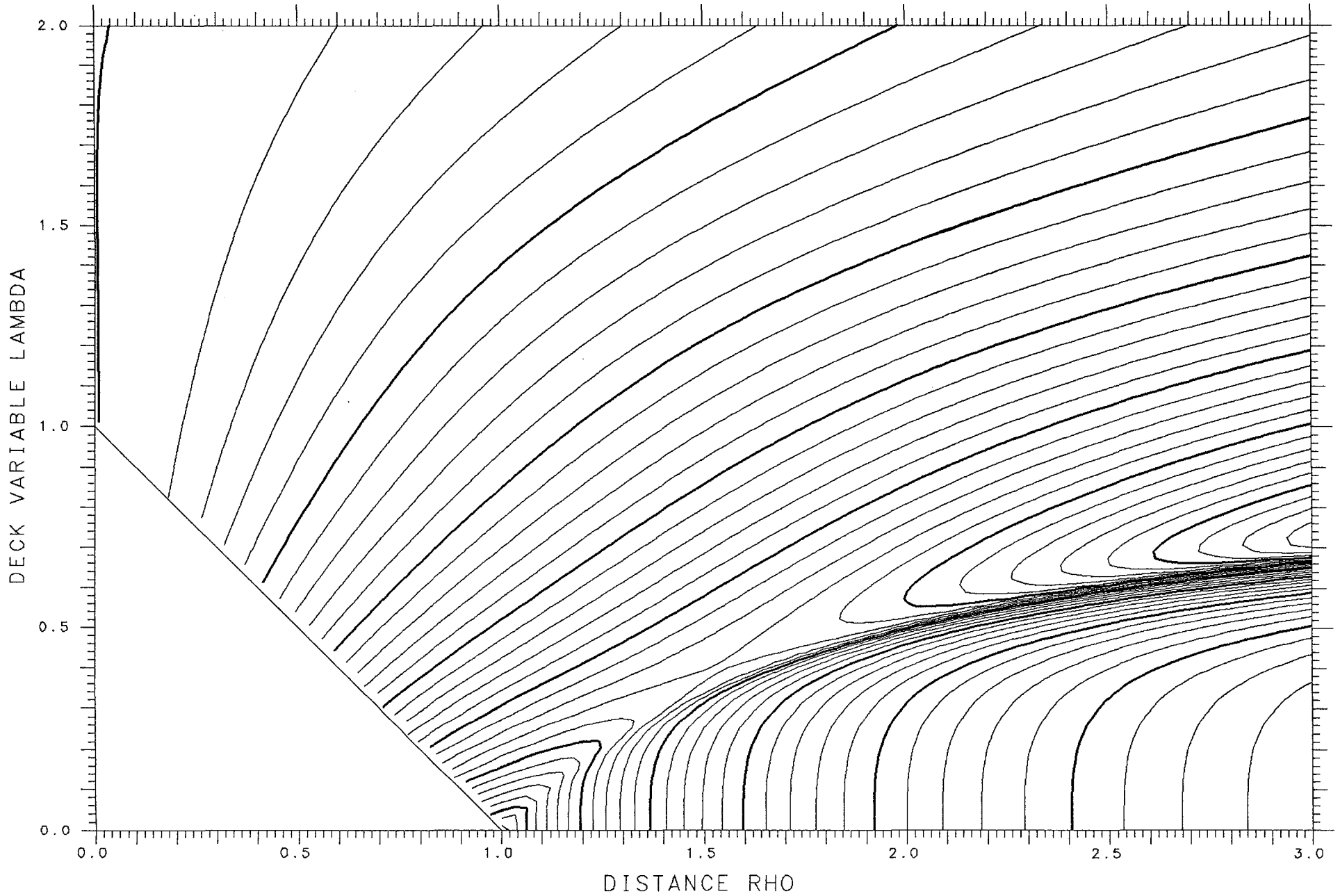

X= .950

ASYMMETRY DELTA= .125

FRACTIONAL= .6800

SPHERES -.37531

TANGENT .06542

LENGTH 12.827

ENERGY 722.20

SPACING .002

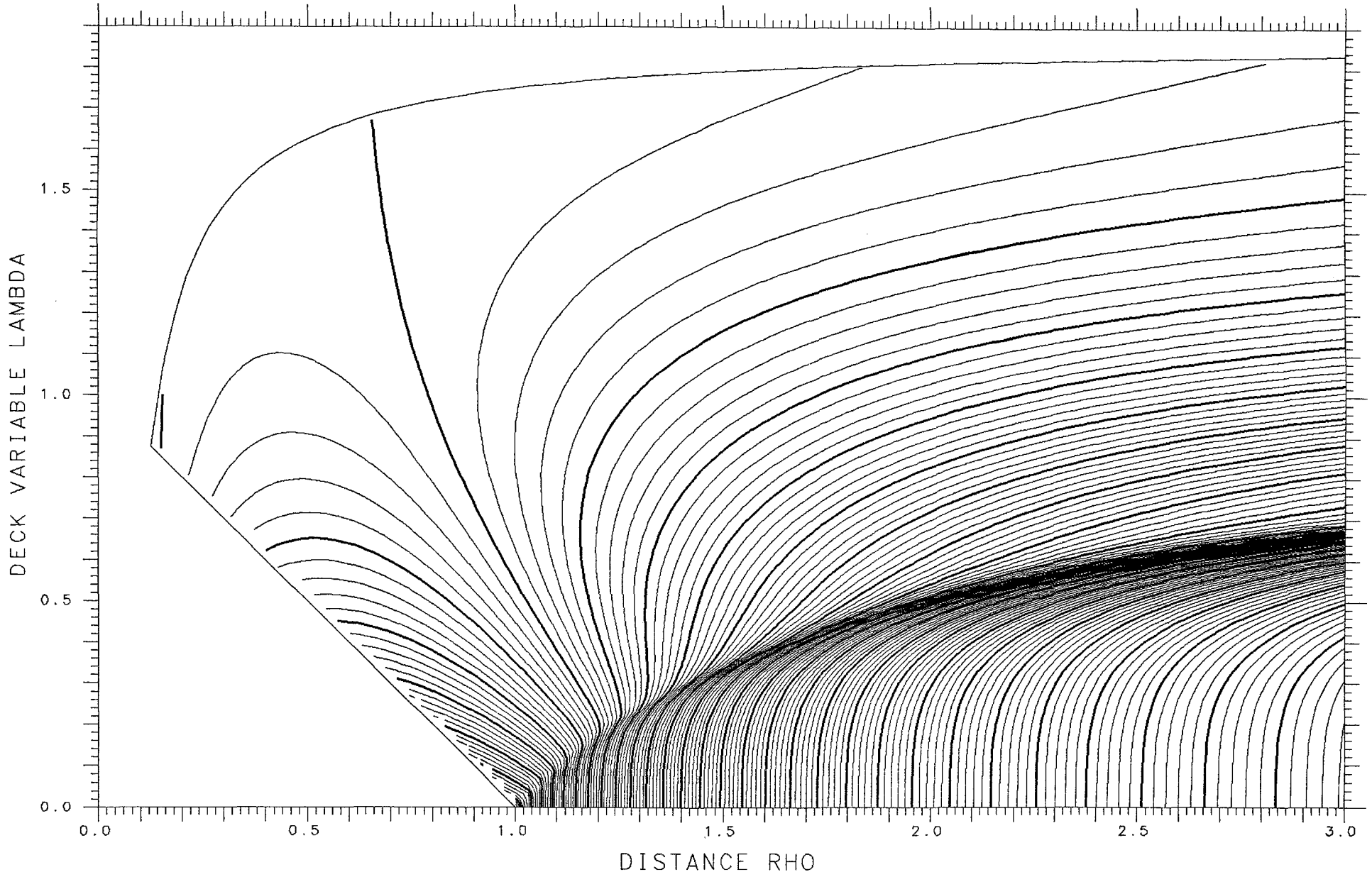

X= .450

ASYMMETRY DELTA= .025

FRACTIONAL= .5374

SPHERES -.07213

TANGENT .16292

LENGTH 9.639

ENERGY 423.38

SPACING .005

SADDLE .11531

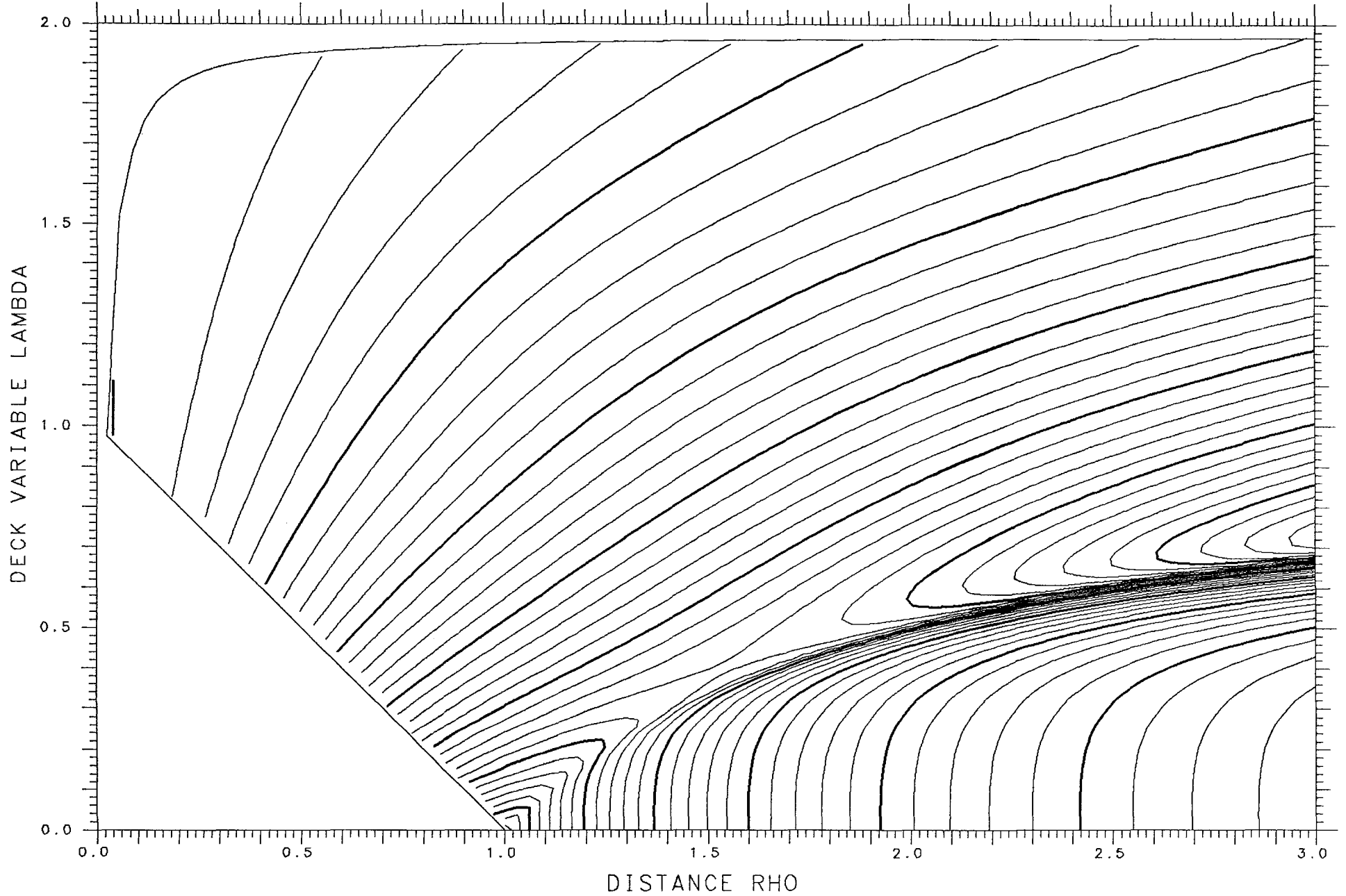

X= .950

ASYMMETRY DELTA= .100

FRACTIONAL= .6461

SPHERES -.39841

TANGENT .06223

LENGTH 12.896

ENERGY 722.20

SPACING .002

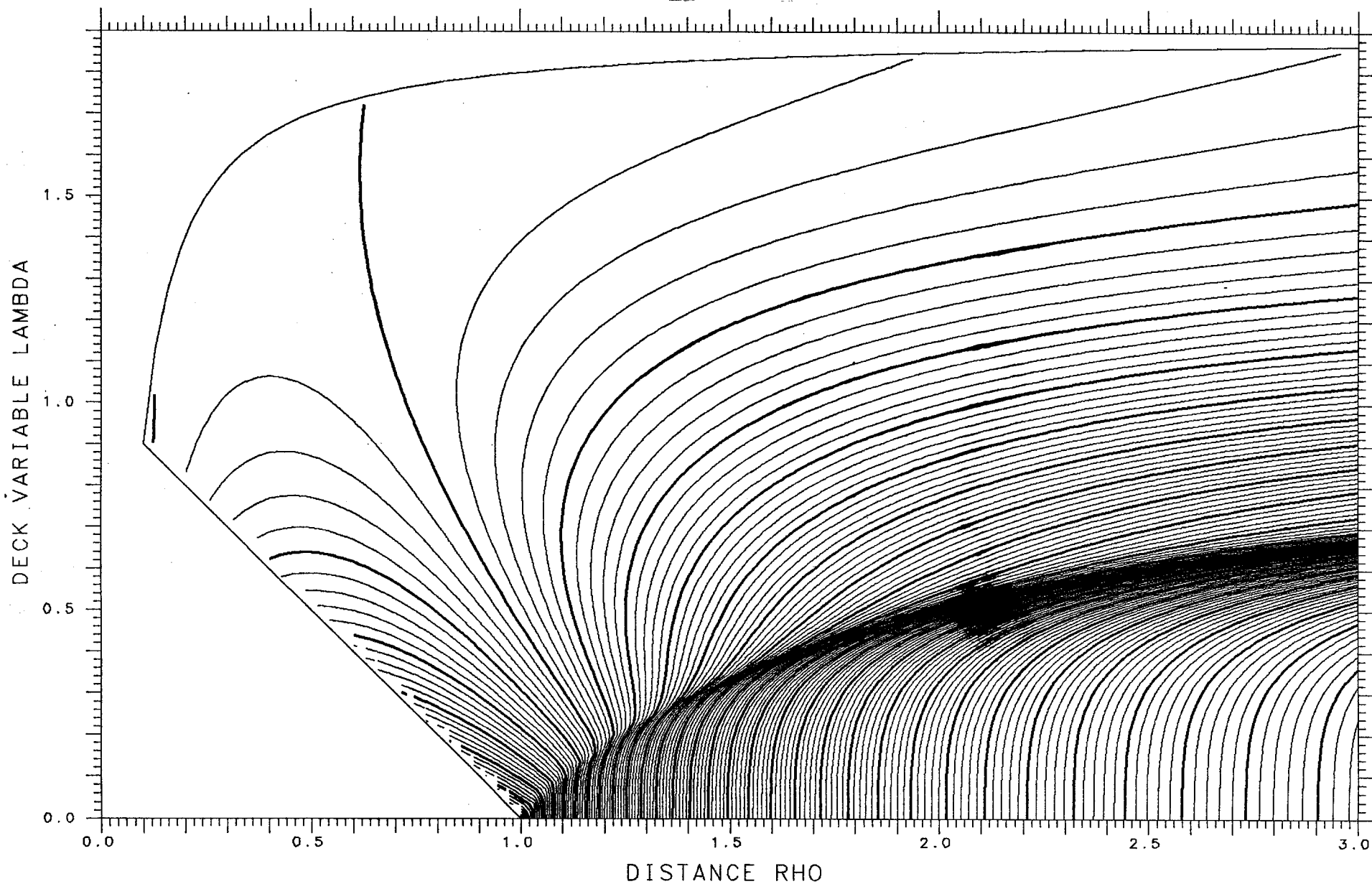

X= .450 ASYMMETRY DELTA= .050 FRACTIONAL= .5745

SPHERES -.06924 TANGENT .16232 LENGTH 9.621 ENERGY 423.38 SPACING .005 SADDLE .11562

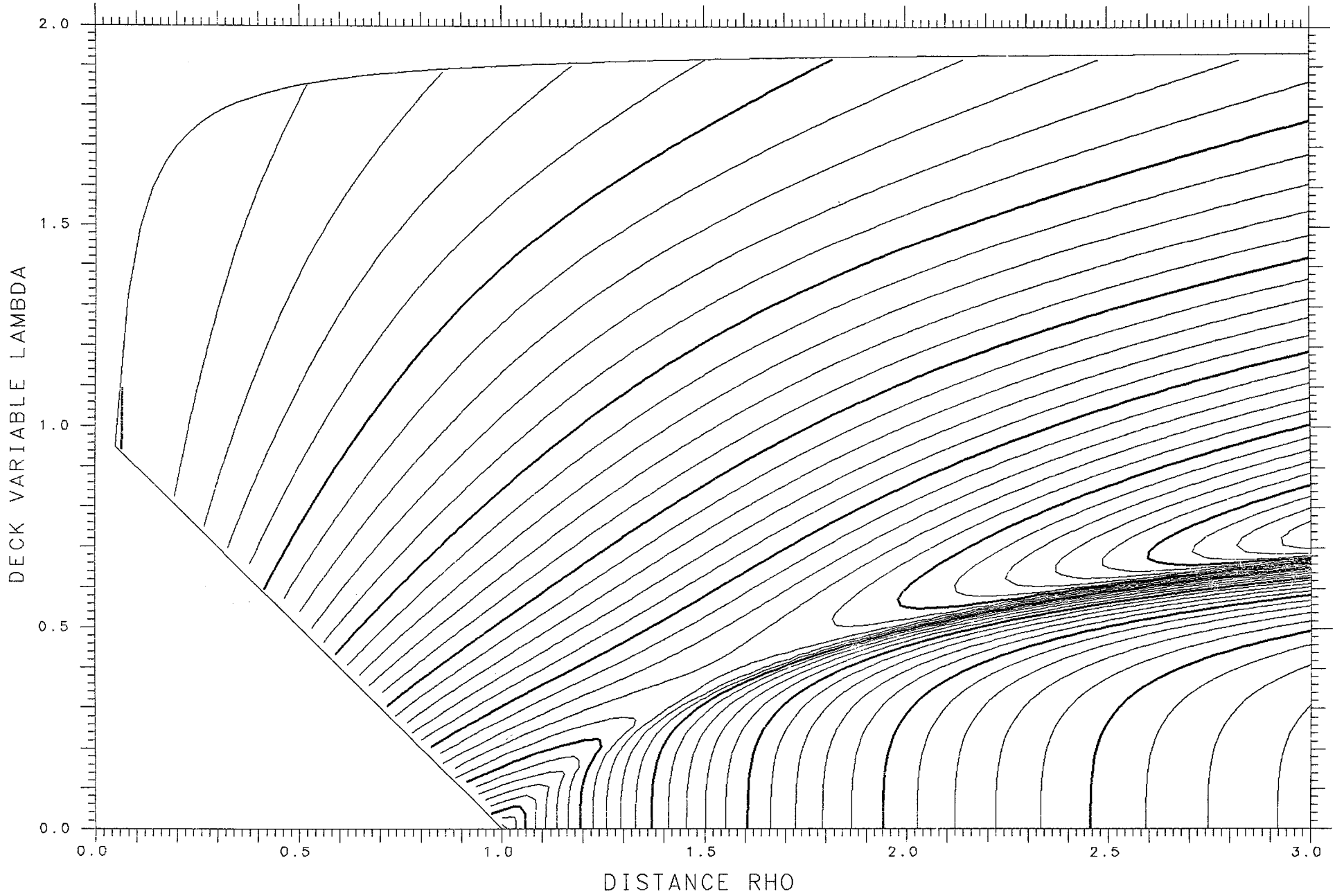

X= .950

ASYMMETRY DELTA= .075

FRACTIONAL= .6108

SPHERES -.41739

TANGENT .05948

LENGTH 12.952

ENERGY 722.20

SPACING .002

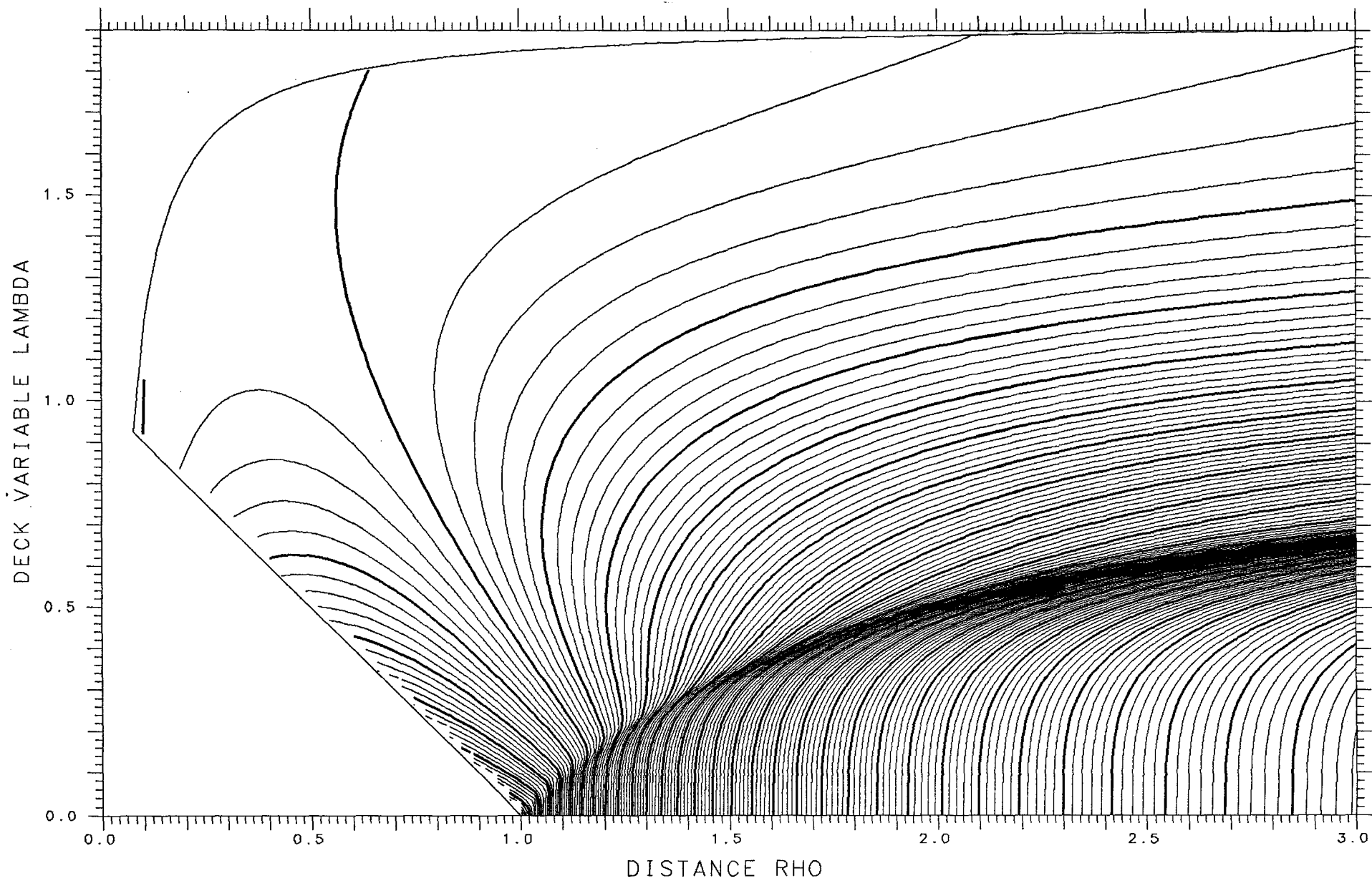

X= .450 ASYMMETRY DELTA= .075 FRACTIONAL= .6108

SPHERES -.06458 TANGENT .16131 LENGTH 9.591 ENERGY 423.38 SPACING .005 SADDLE .11608

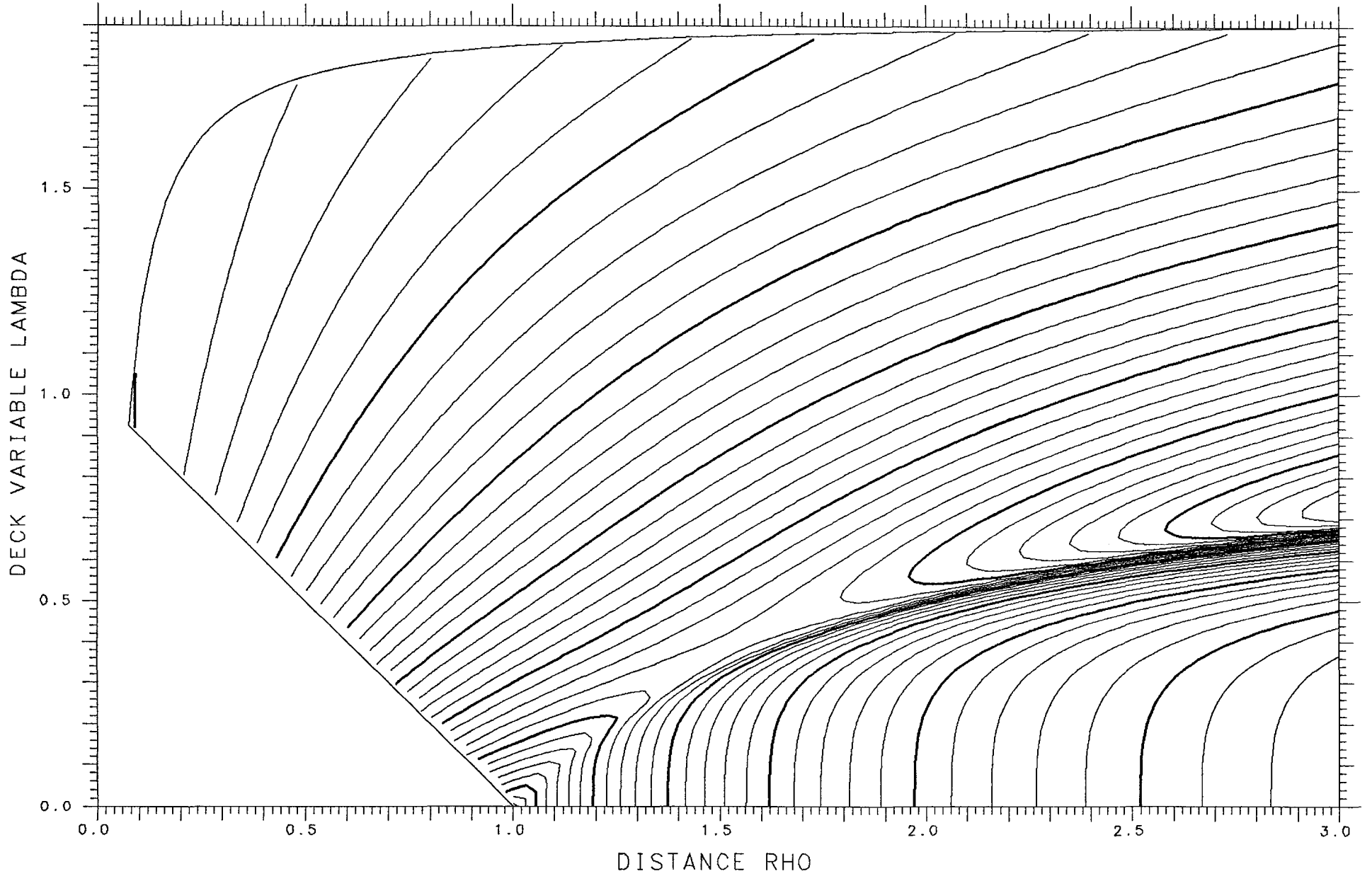

X= .950

ASYMMETRY DELTA= .050

FRACTIONAL= .5745

SPHERES -.43150

TANGENT .05736

LENGTH 12.992

ENERGY 722.20

SPACING .002

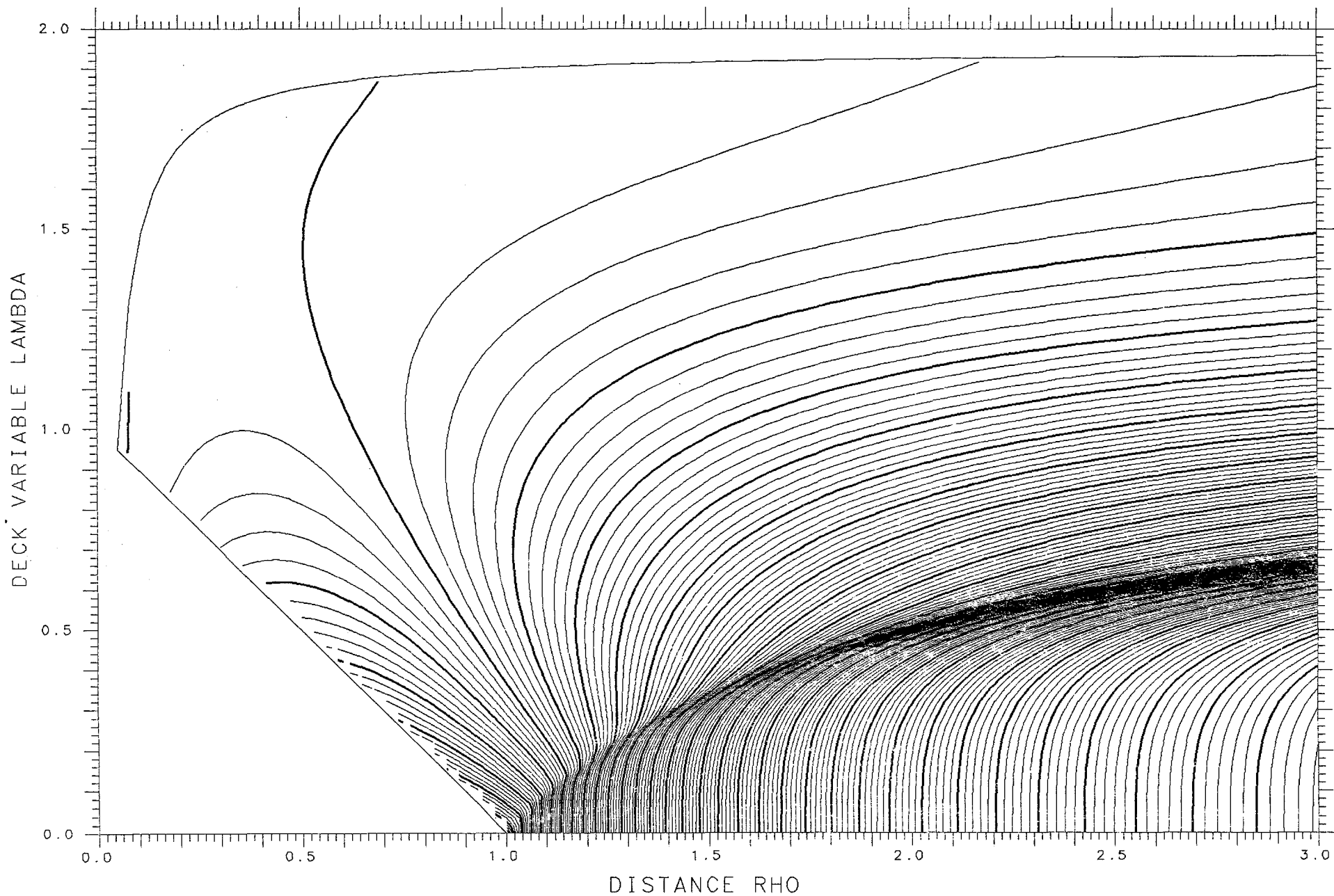

X= .450 ASYMMETRY DELTA= .100 FRACTIONAL= .6461

SPHERES -.05836 TANGENT .15984 LENGTH 9.551 ENERGY 423.38 SPACING .005 SADDLE .11660

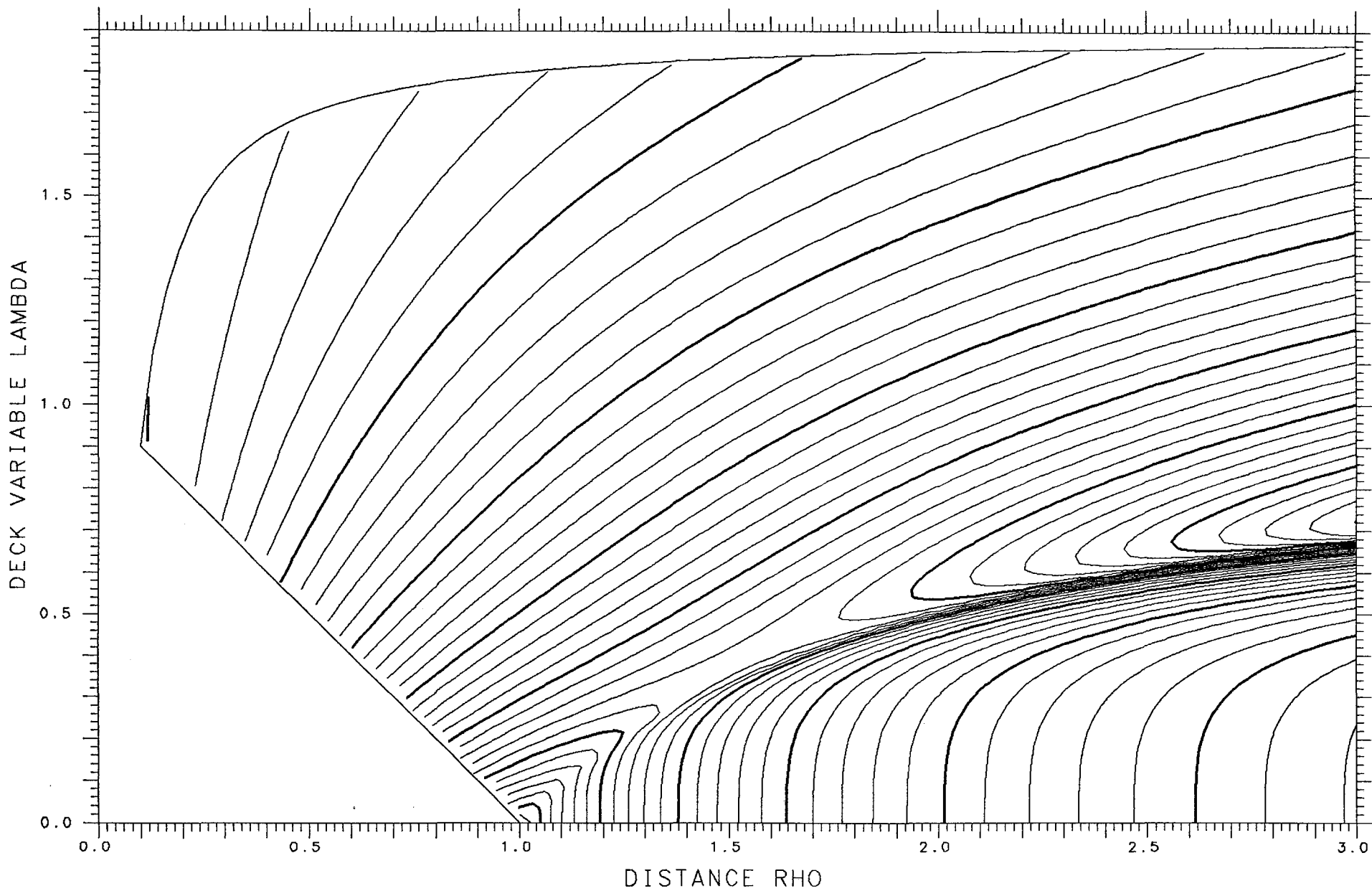

X= .950

ASYMMETRY DELTA= .025

FRACTIONAL= .5374

SPHERES -.44021

TANGENT .05602

LENGTH 13.016

ENERGY 722.20

SPACING .002

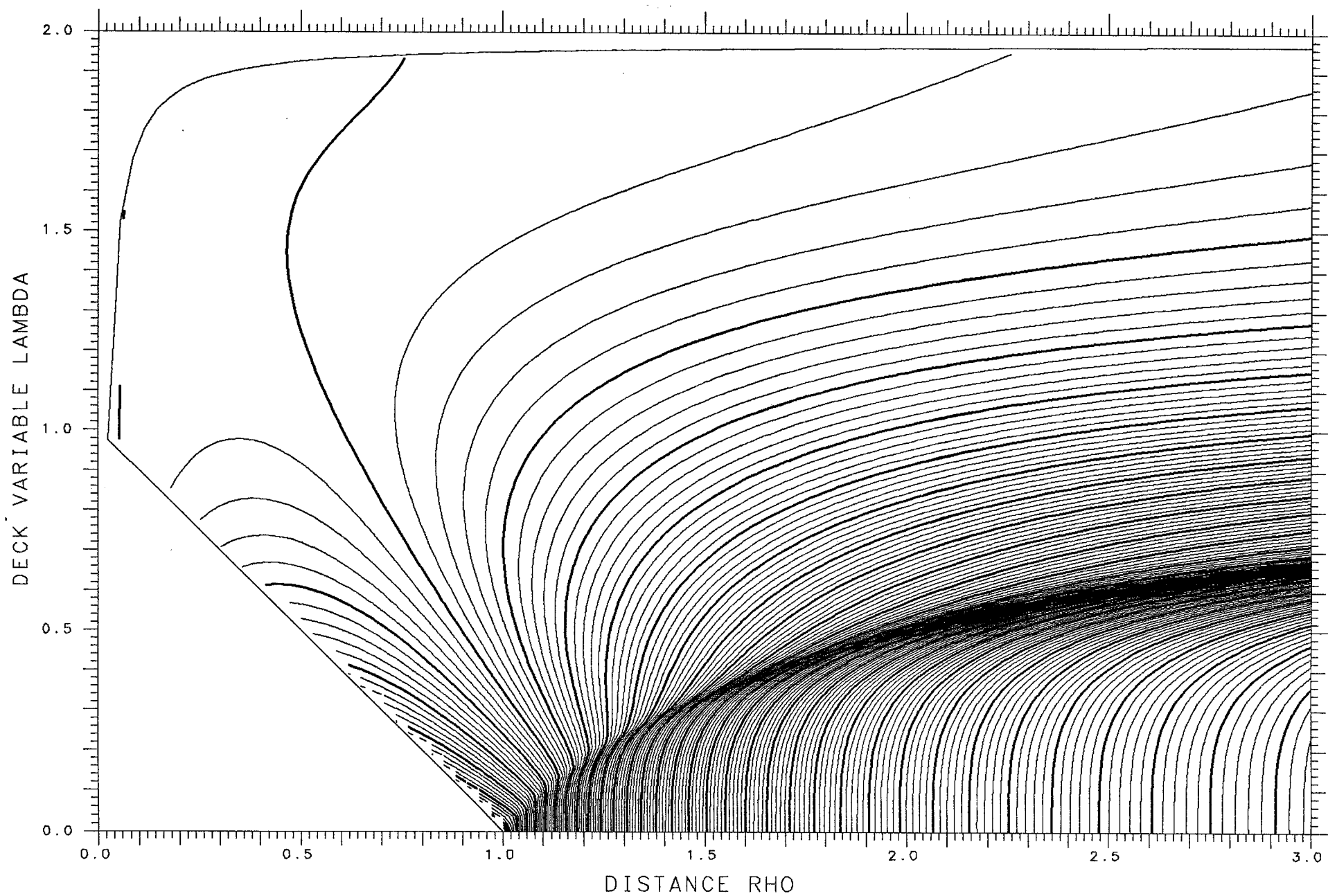

X= .450 ASYMMETRY DELTA= .125 FRACTIONAL= .6800

SPHERES -.05087 TANGENT .15790 LENGTH 9.499 ENERGY 423.38 SPACING .005 SADDLE .11711

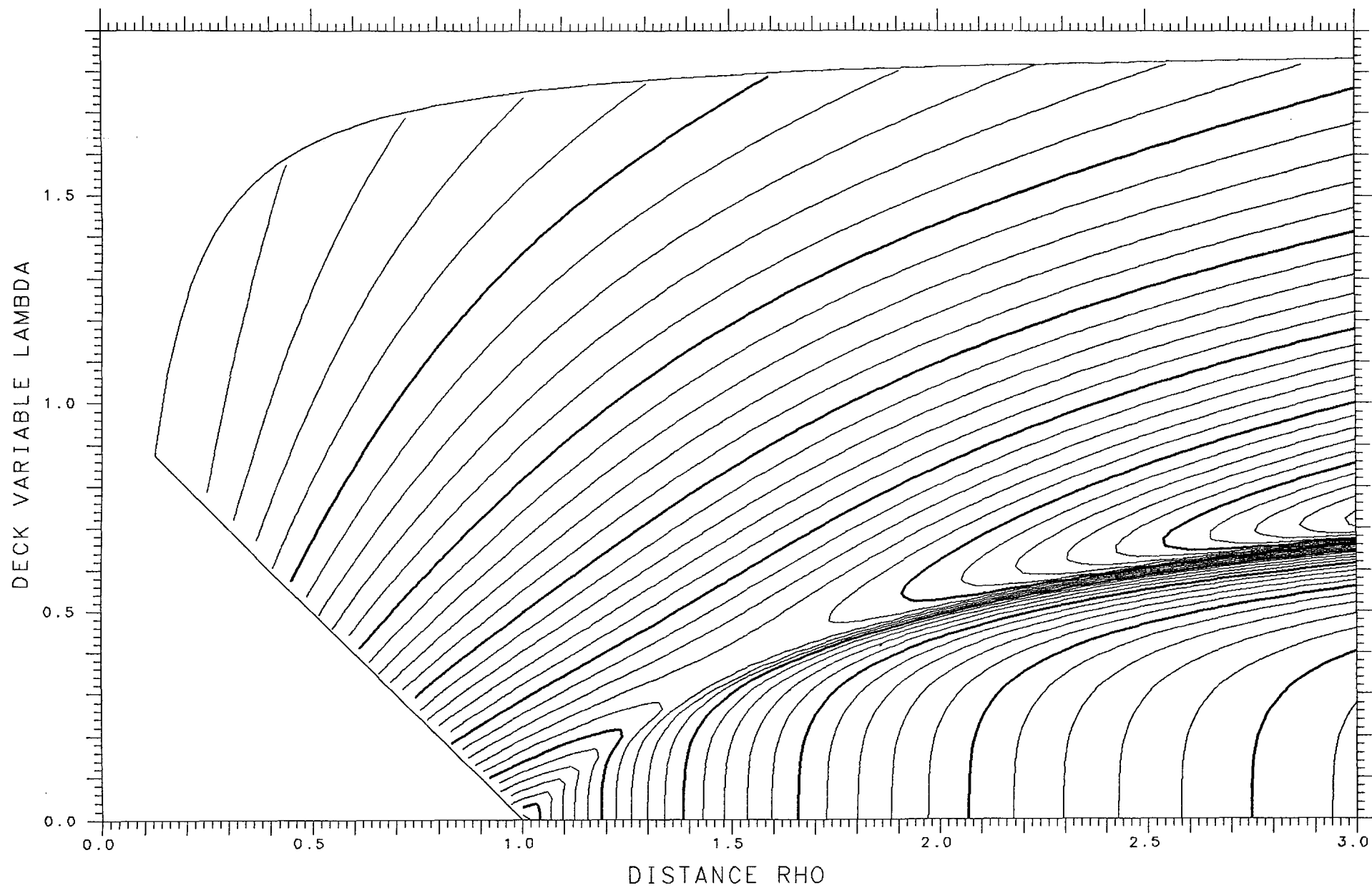

X= .950

ASYMMETRY DELTA=0.

FRACTIONAL= .5000

SPHERES -.44315

TANGENT .05556

LENGTH 13.024

ENERGY 722.20

SPACING .002

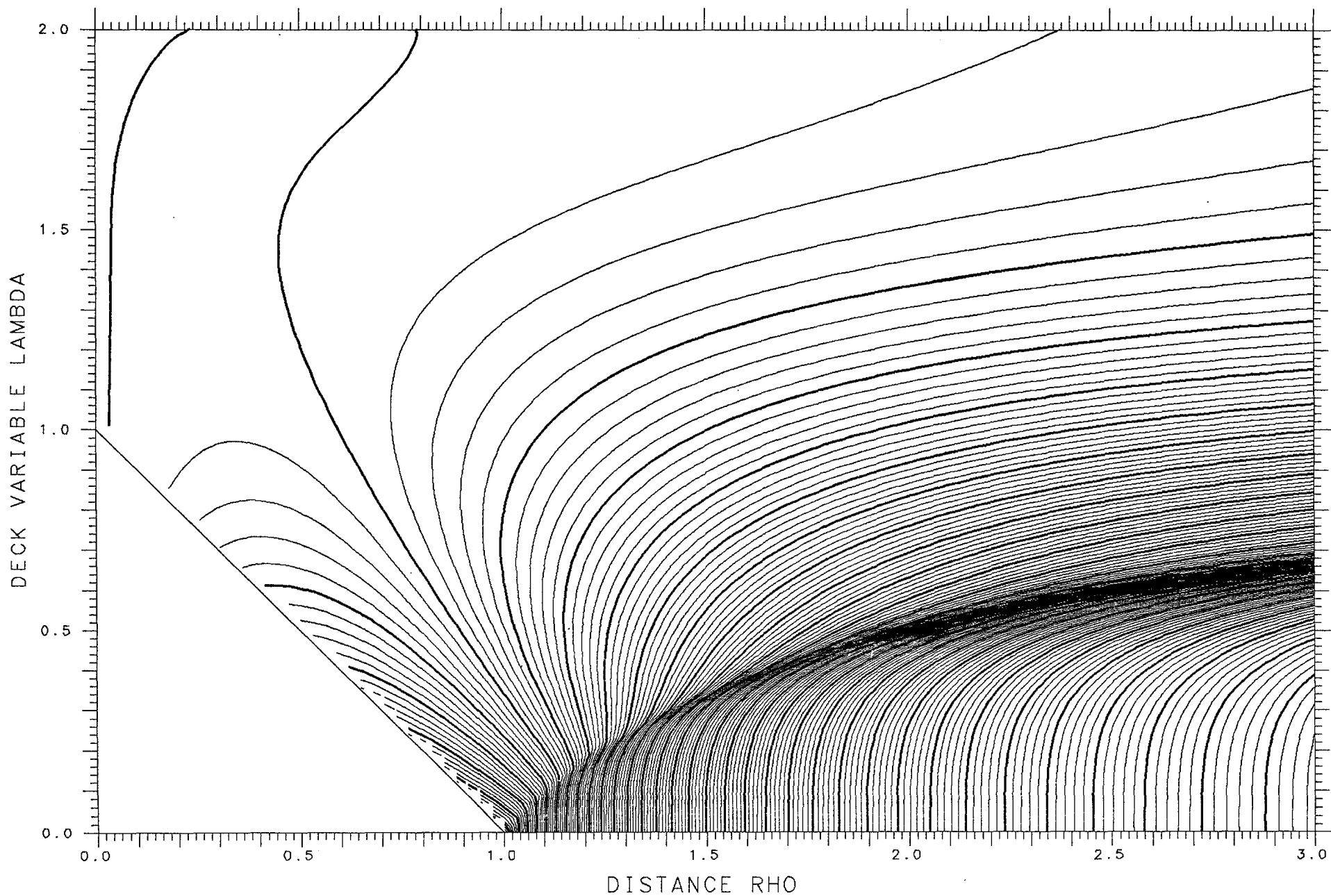

X= .450 ASYMMETRY DELTA= .150 FRACTIONAL= .7124

SPHERES -.04245 TANGENT .15544 LENGTH 9.437 ENERGY 423.38 SPACING .005 SADDLE .11746

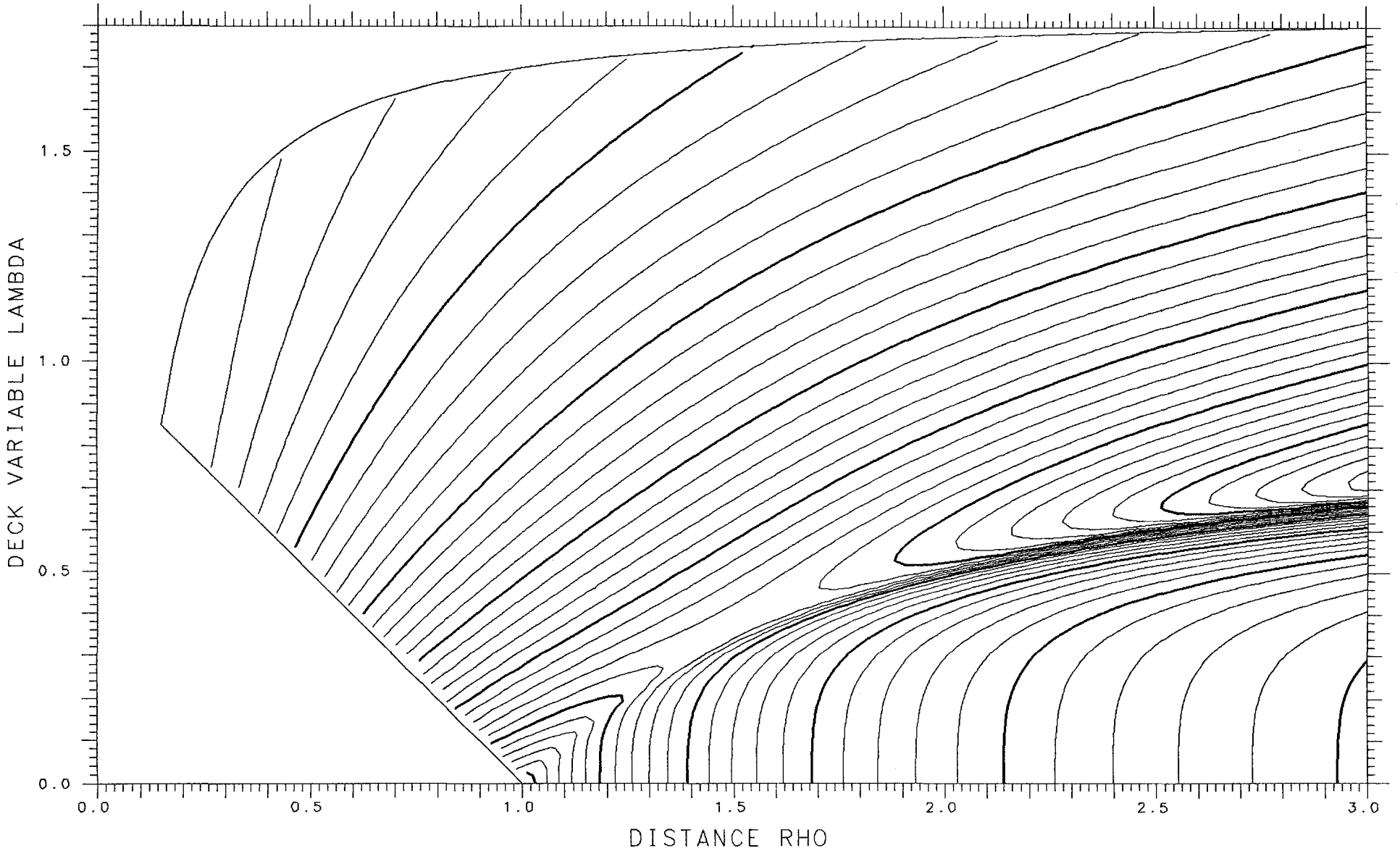

X= .925 ASYMMETRY DELTA= .600 FRACTIONAL= .9846

SPHERES .00614 TANGENT .04370 LENGTH 10.095 ENERGY 709.11 SPACING .002

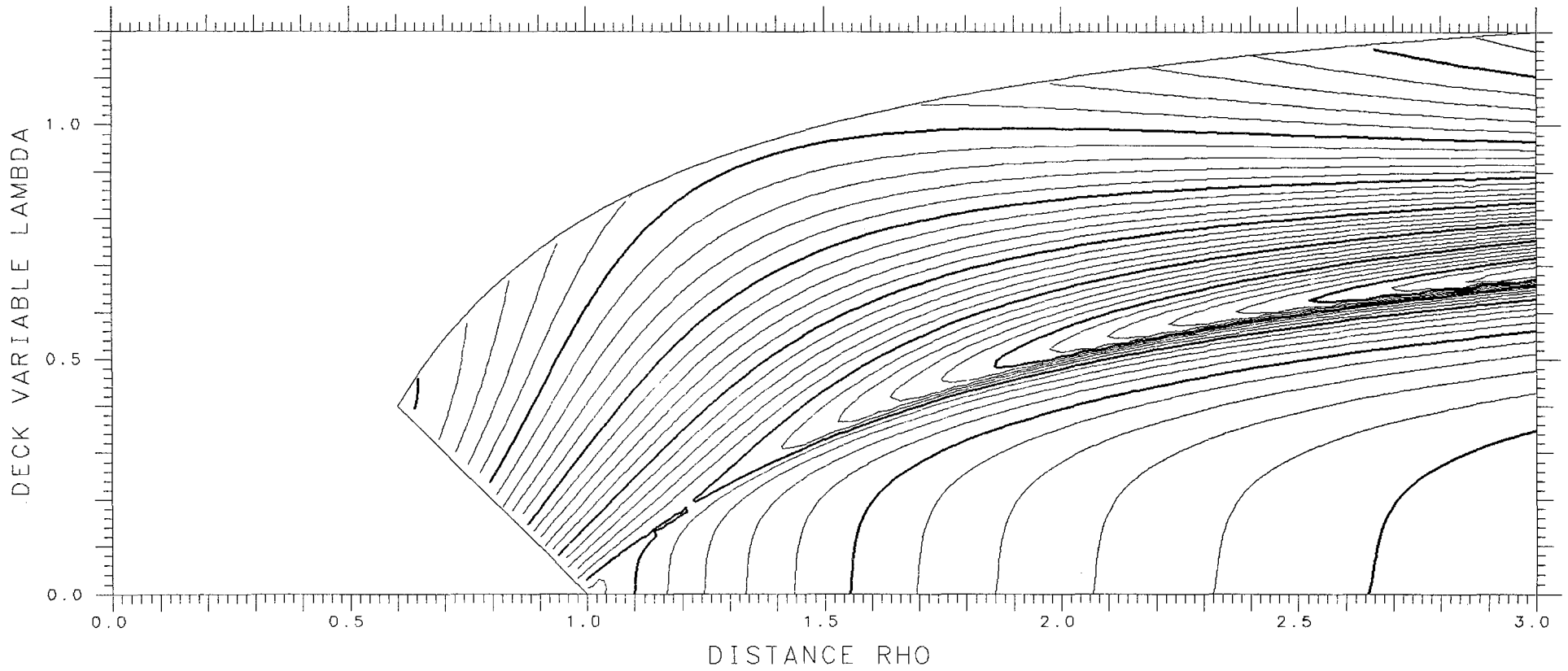

X= .450 ASYMMETRY DELTA= .175 FRACTIONAL= .7429

SPHERES -.03342 TANGENT .15244 LENGTH 9.367 ENERGY 423.38 SPACING .005 SADDLE .11756

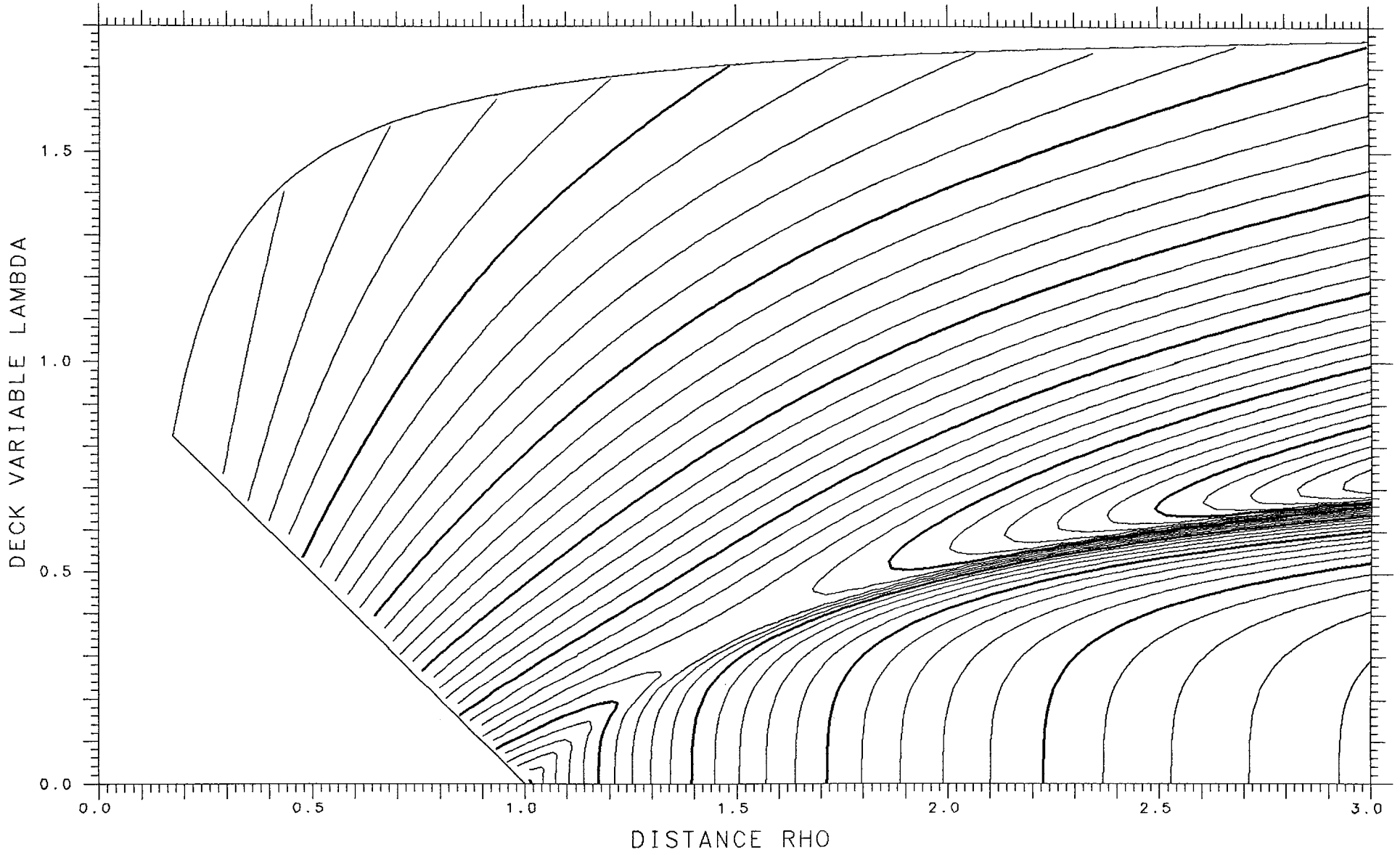

X= .925 ASYMMETRY DELTA= .575 FRACTIONAL= .9807

SPHERES .00252 TANGENT .04870 LENGTH 10.242 ENERGY 709.11 SPACING .002

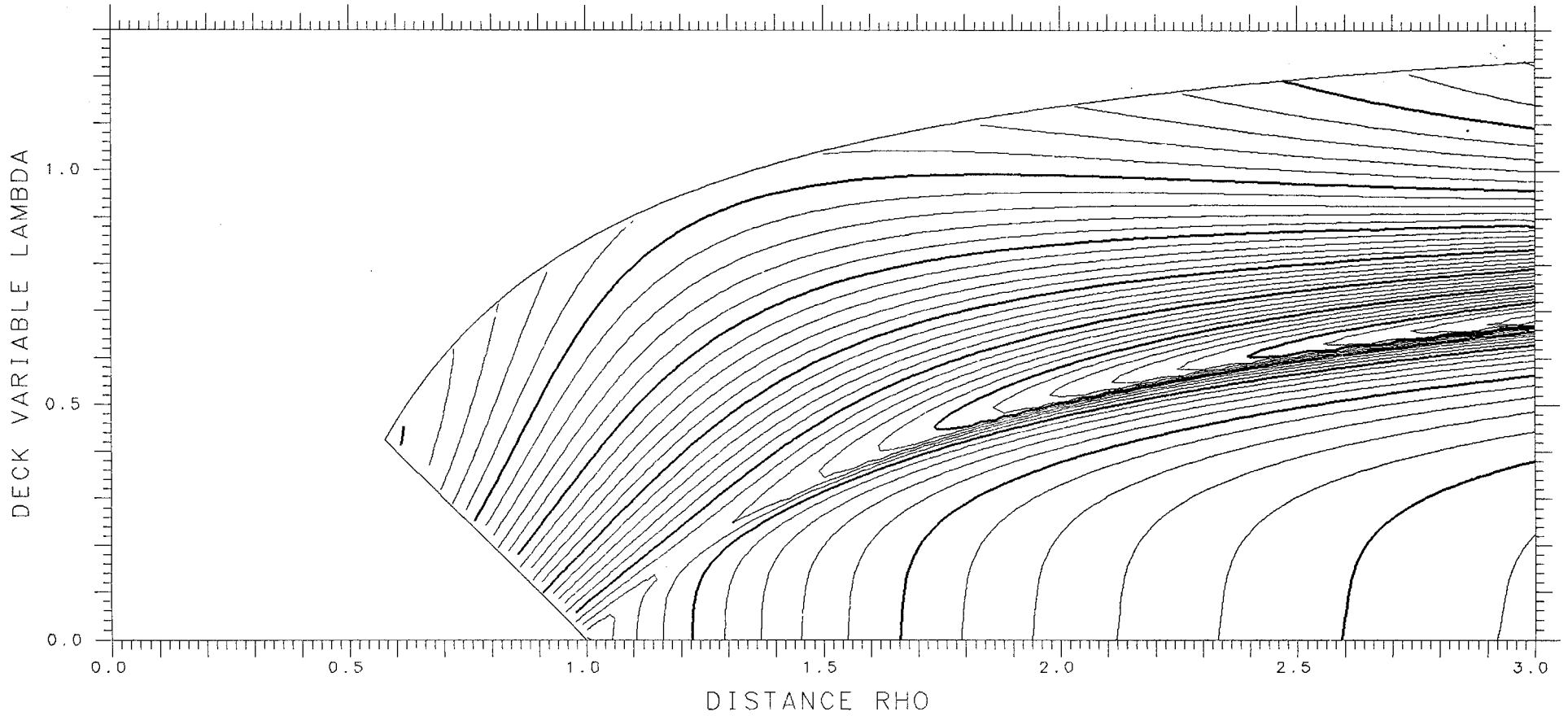

X= .450 ASYMMETRY DELTA= .200 FRACTIONAL= .7714

SPHERES -.02414 TANGENT .14889 LENGTH 9.288 ENERGY 423.38 SPACING .005 SADDLE .11727

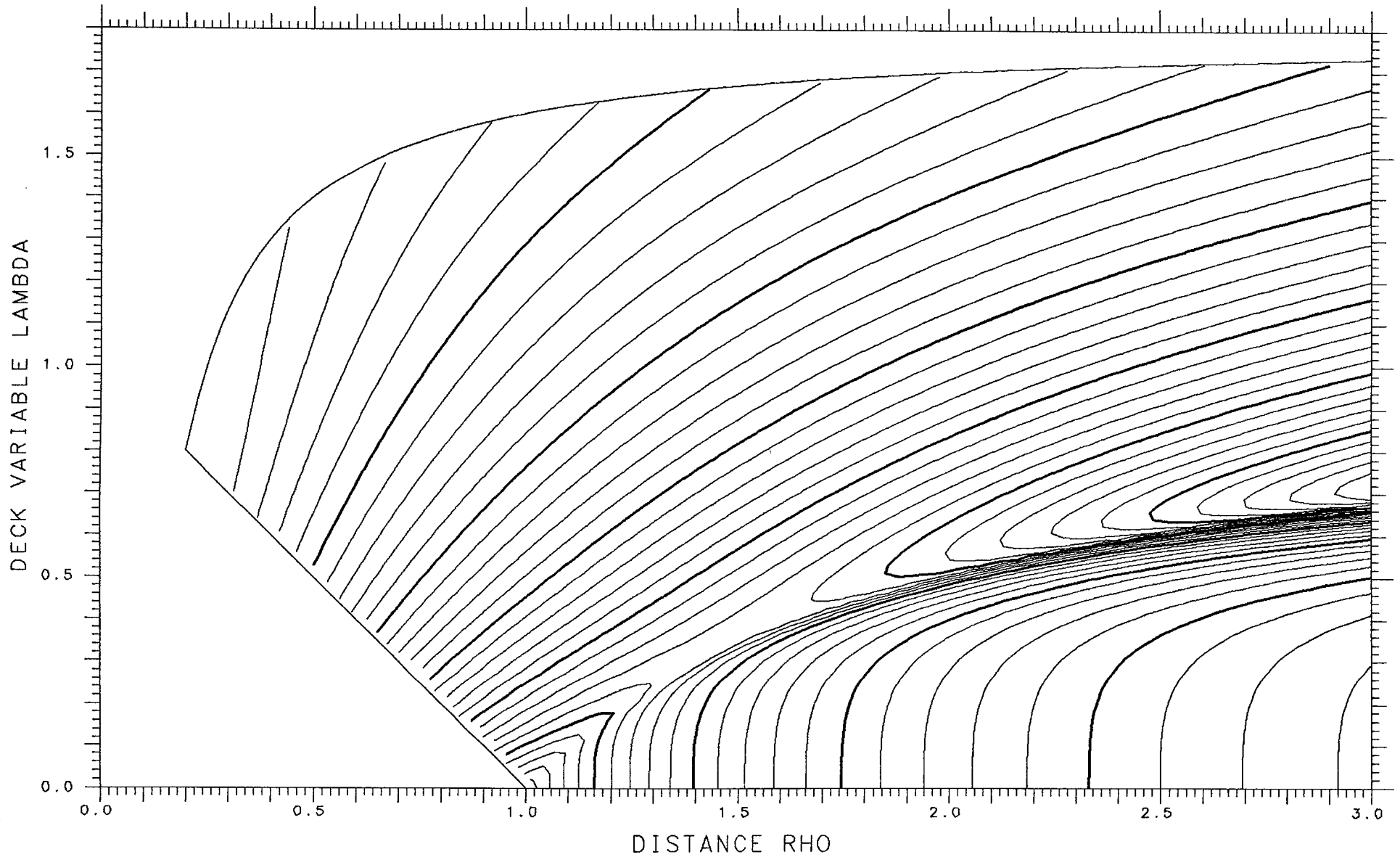

X= .925 ASYMMETRY DELTA= .550 FRACTIONAL= .9761

SPHERES -.00244 TANGENT .05372 LENGTH **10.391** ENERGY **709.11** SPACING .002

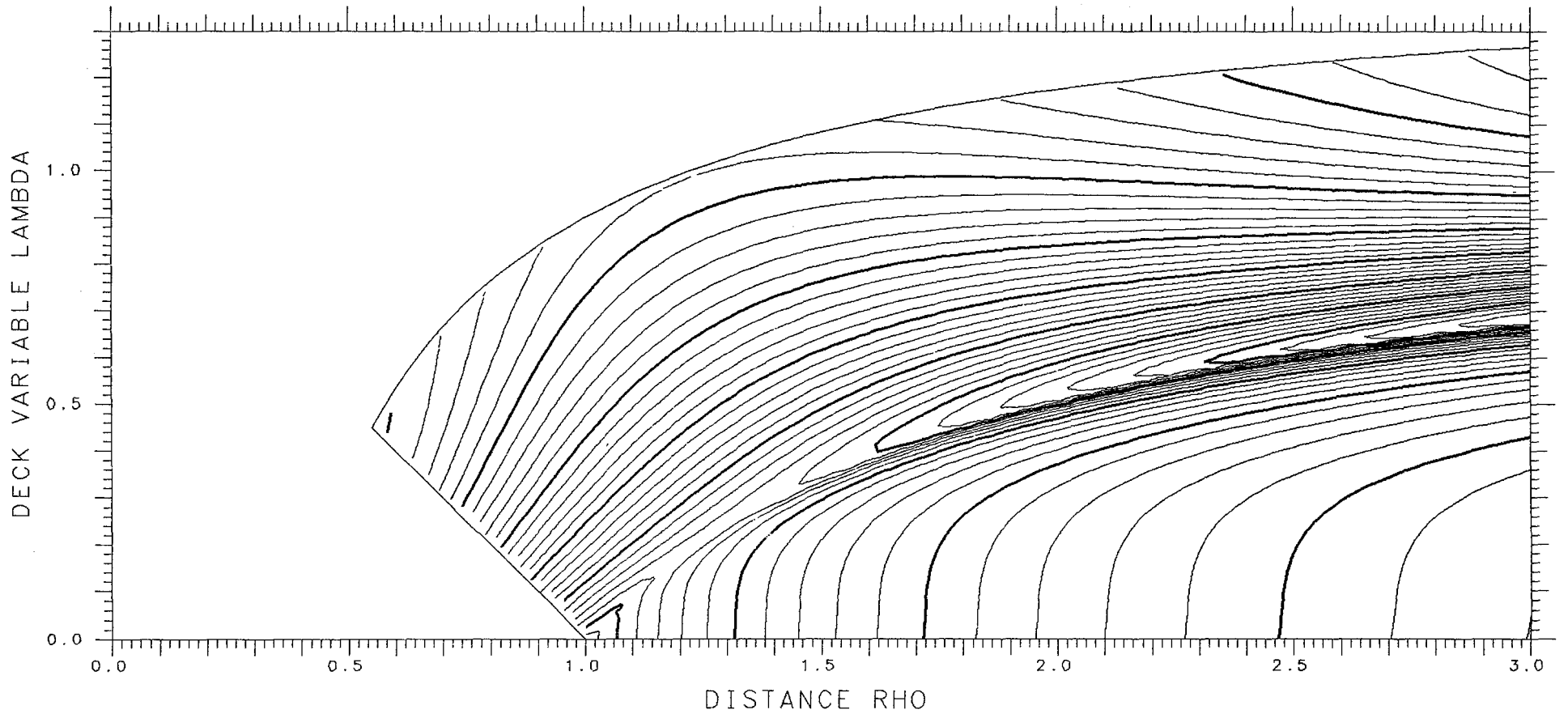

X= .450 ASYMMETRY DELTA= .225 FRACTIONAL= .7979

SPHERES -.01493 TANGENT .14478 LENGTH 9.201 ENERGY 423.38 SPACING .005 SADDLE .11650

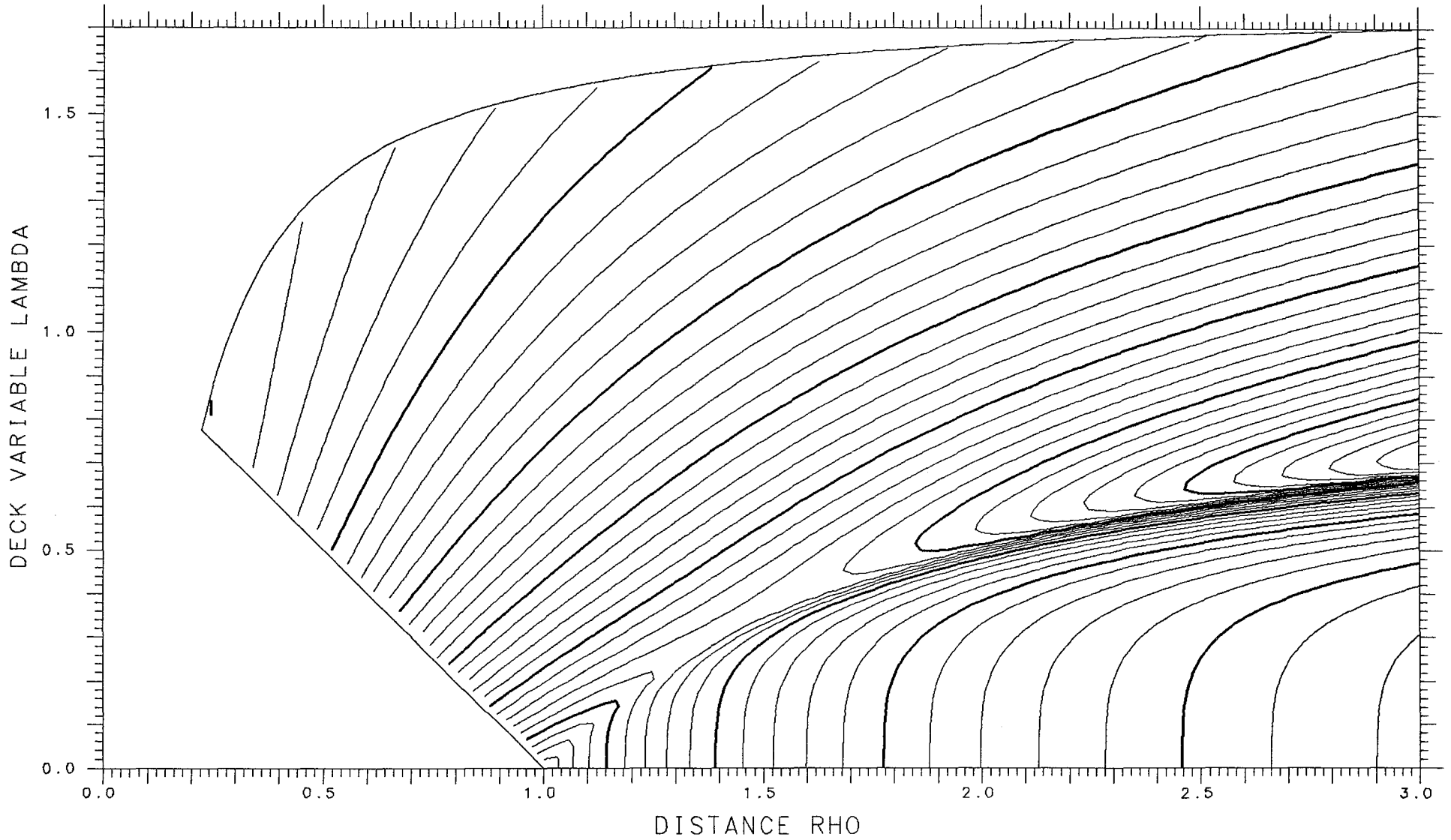

X= .925 ASYMMETRY DELTA= .525 FRACTIONAL= .9707

SPHERES - .00893 TANGENT .05867 LENGTH 10.52 ENERGY 709.11 SPACING .002

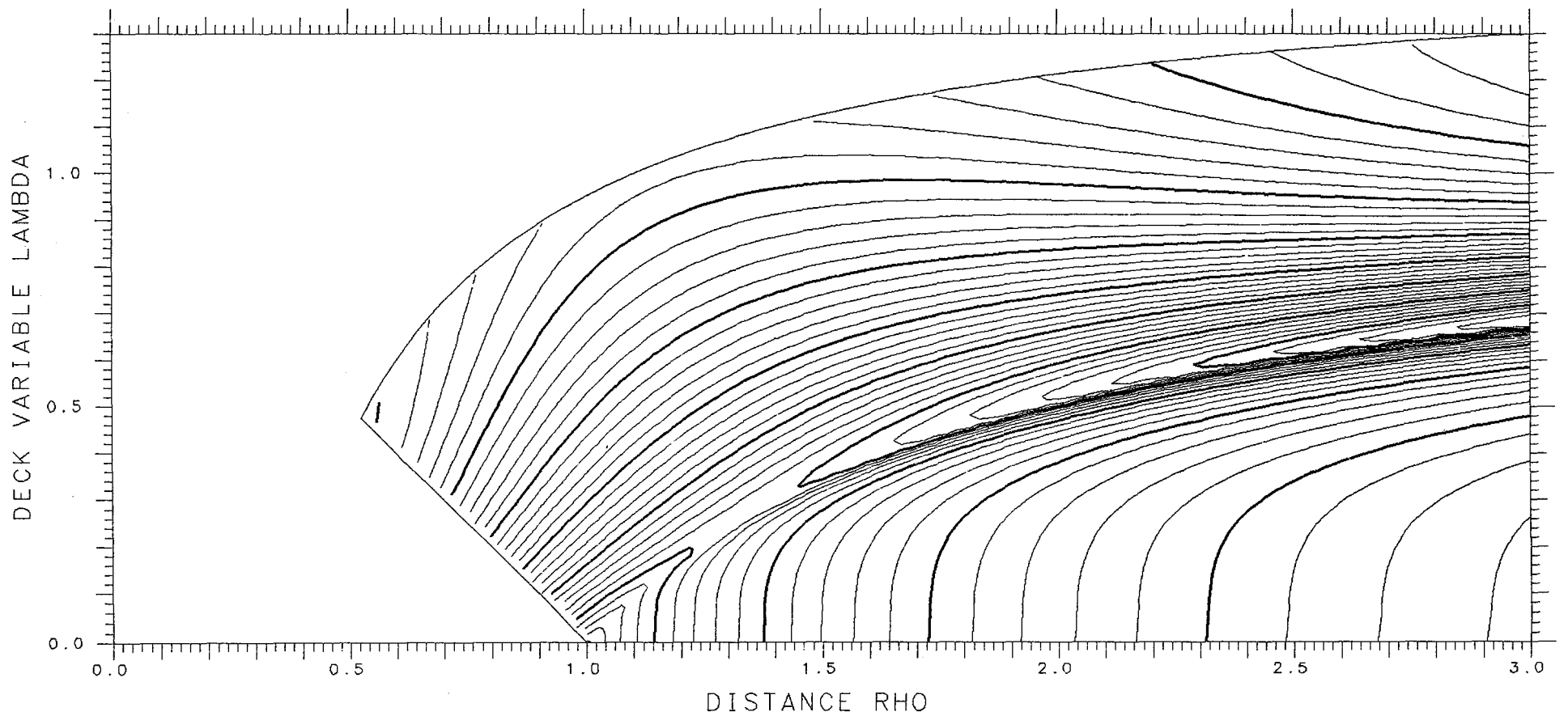

X= .450 ASYMMETRY DELTA= .250 FRACTIONAL= .8224

SPHERES -.00606 TANGENT .14011 LENGTH 9.108 ENERGY 423.38 SPACING .005 SADDLE .11516

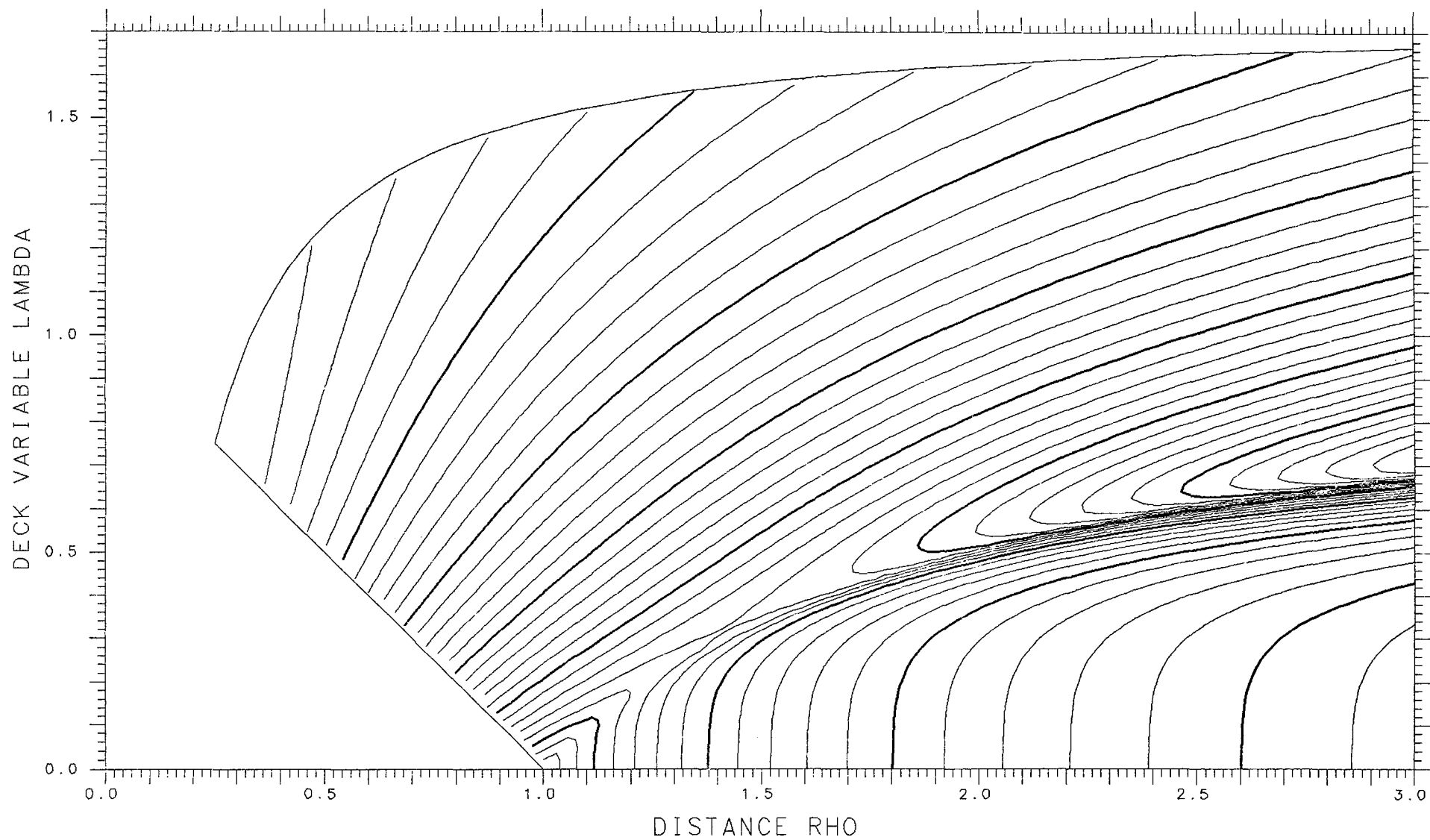

X= .925 ASYMMETRY DELTA= .500 FRACTIONAL= .9643

SPHERES -.01714 TANGENT .06347 LENGTH 10.694 ENERGY 709.11 SPACING .002

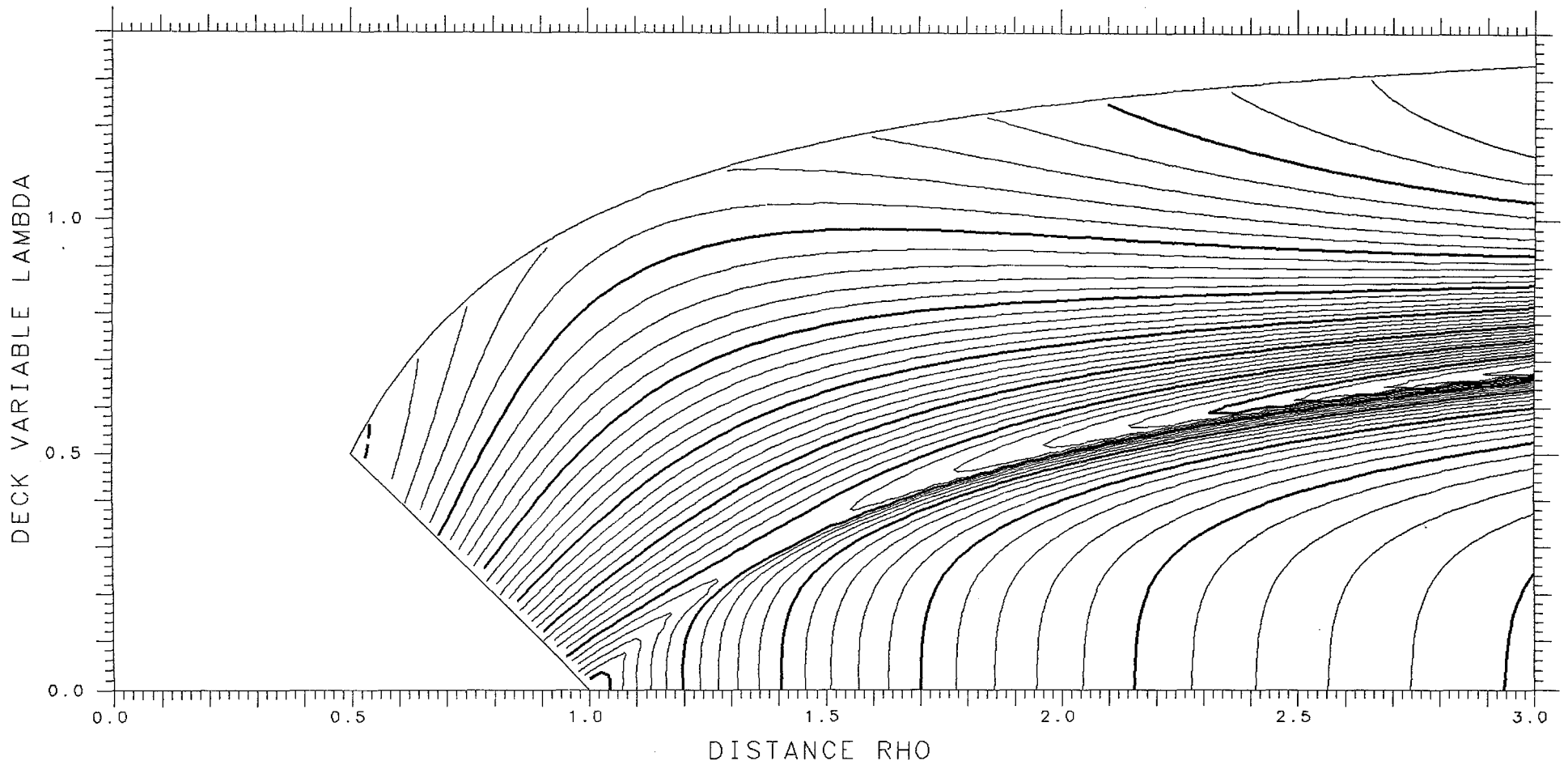

X= .450 ASYMMETRY DELTA= .275 FRACTIONAL= .8447

SPHERES .00222 TANGENT .13492 LENGTH 9.010 ENERGY 423.38 SPACING .005 SADDLE .11319

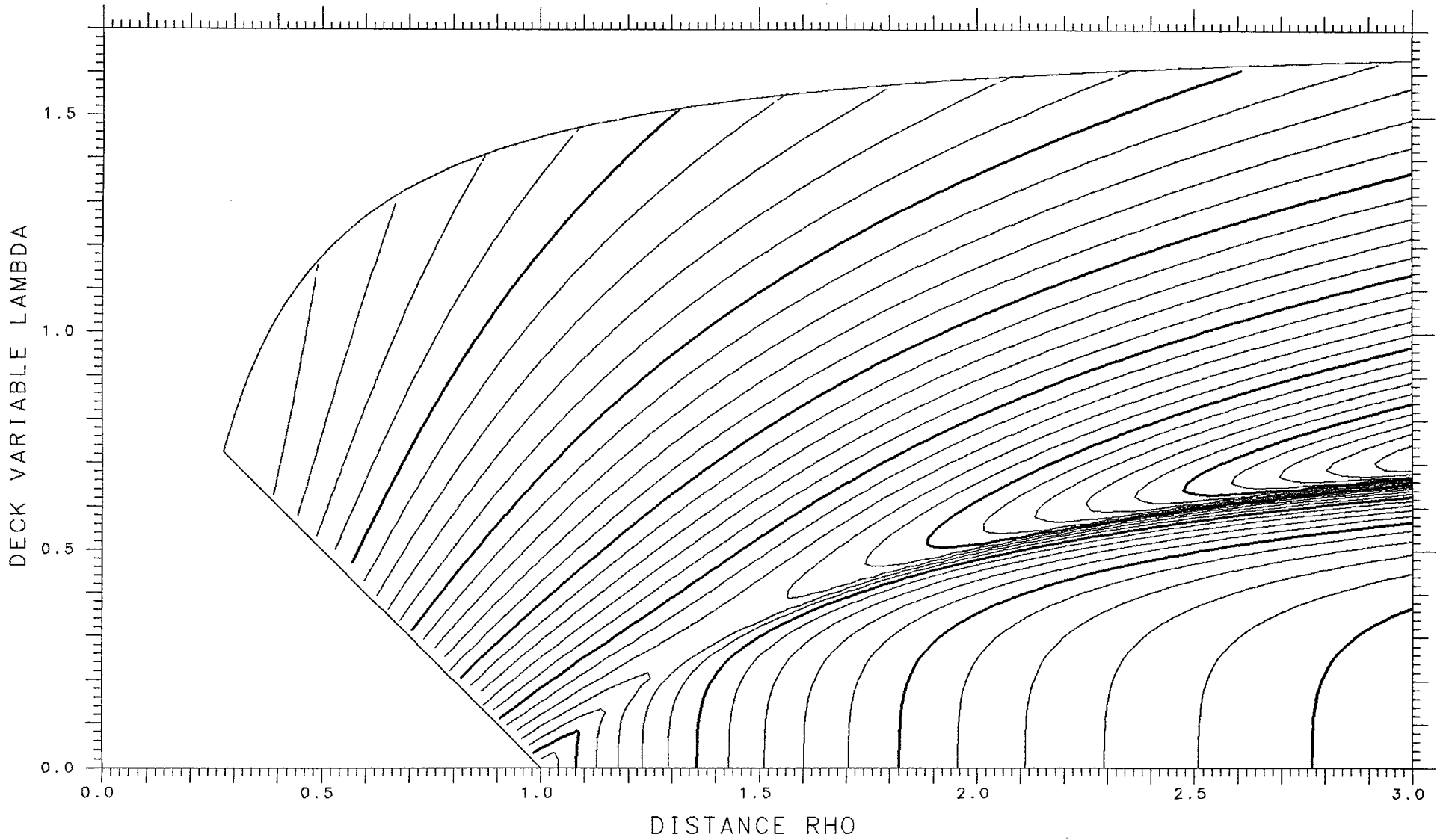

X= .925

ASYMMETRY DELTA= .475

FRACTIONAL= .9569

SPHERES -.02725

TANGENT .06802

LENGTH 10.847

ENERGY 709.11

SPACING .002

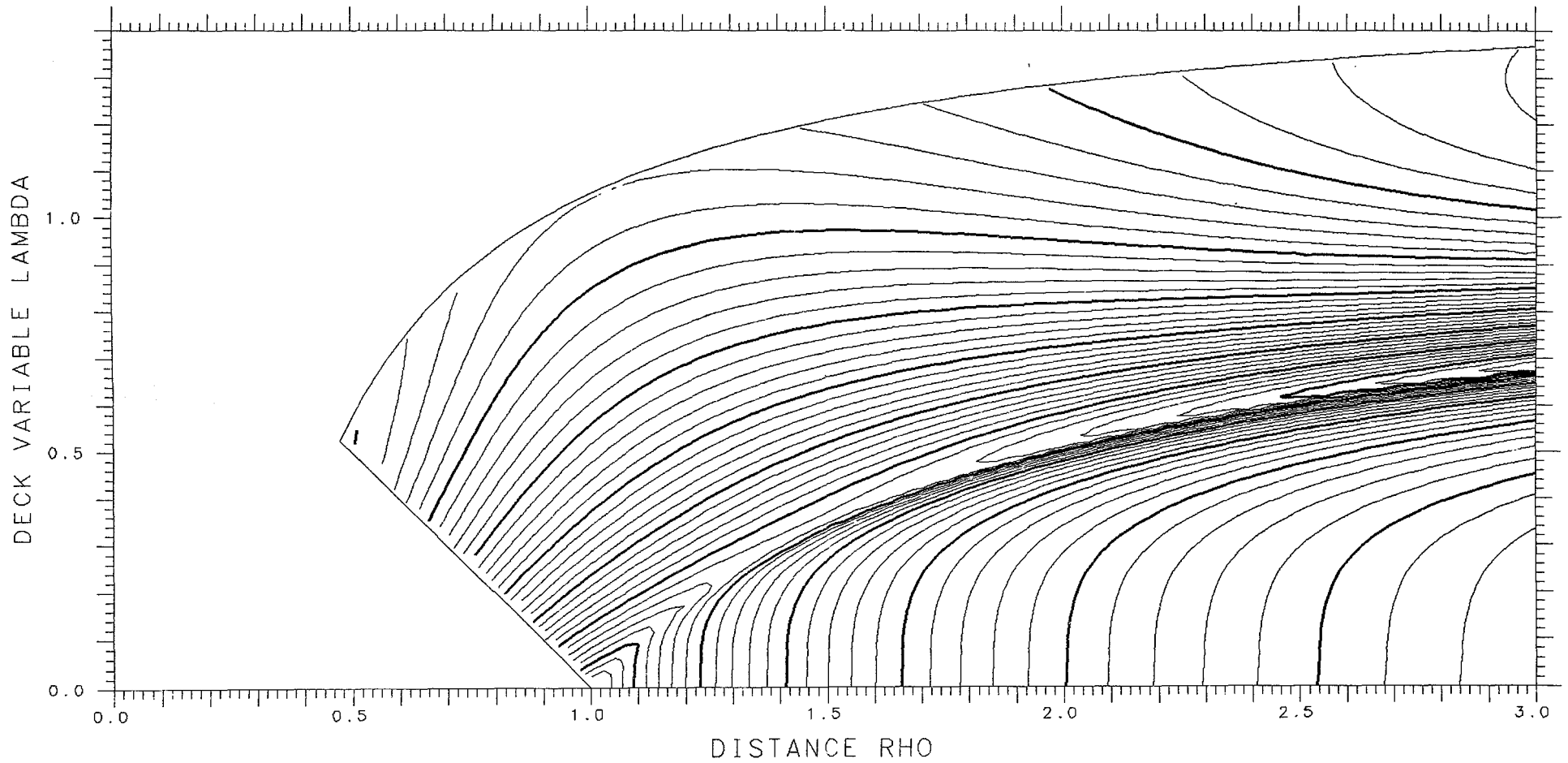

X= .450 ASYMMETRY DELTA= .300 FRACTIONAL= .8650

SPHERES .00972 TANGENT .12925 LENGTH 8.906 ENERGY 423.38 SPACING .005 SADDLE .11058

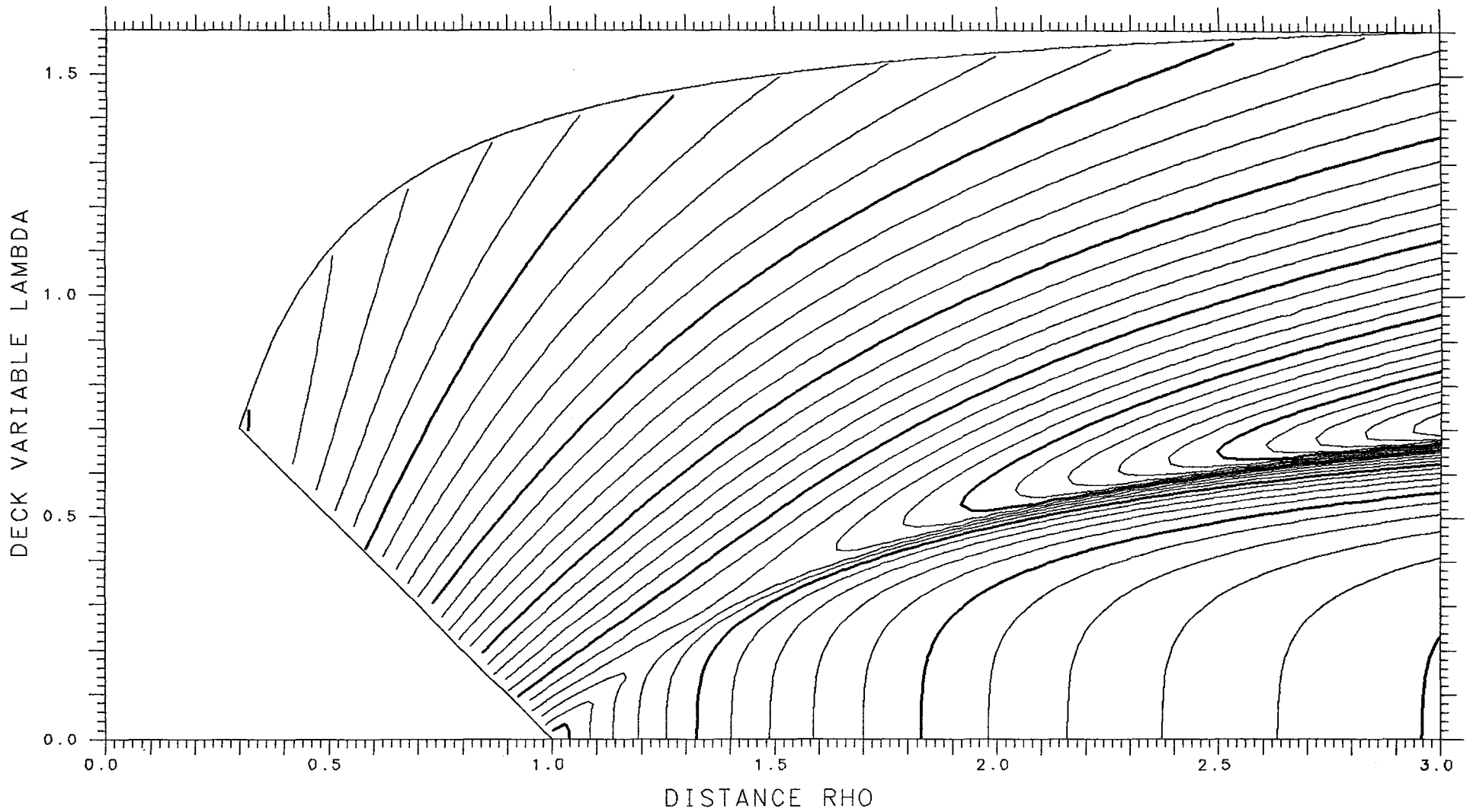

X= .925 ASYMMETRY DELTA= .450 FRACTIONAL= .9483

SPHERES -.03943 TANGENT .07222 LENGTH **11.001** ENERGY 709.11 SPACING .002

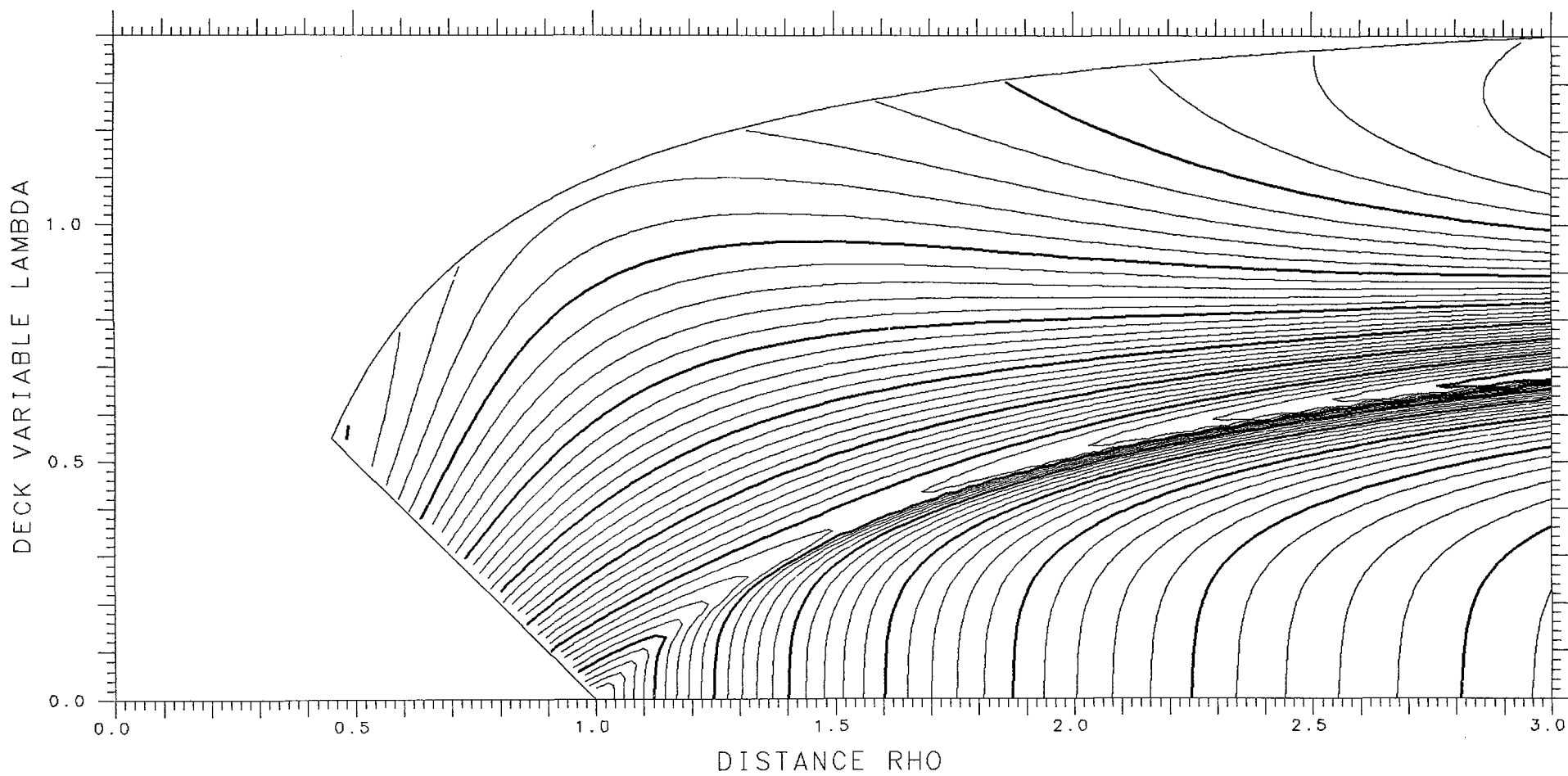

X= .450 ASYMMETRY DELTA= .325 FRACTIONAL= .8832

SPHERES .01632 TANGENT .12314 LENGTH 8.799 ENERGY 423.38 SPACING .005 SADDLE .10733

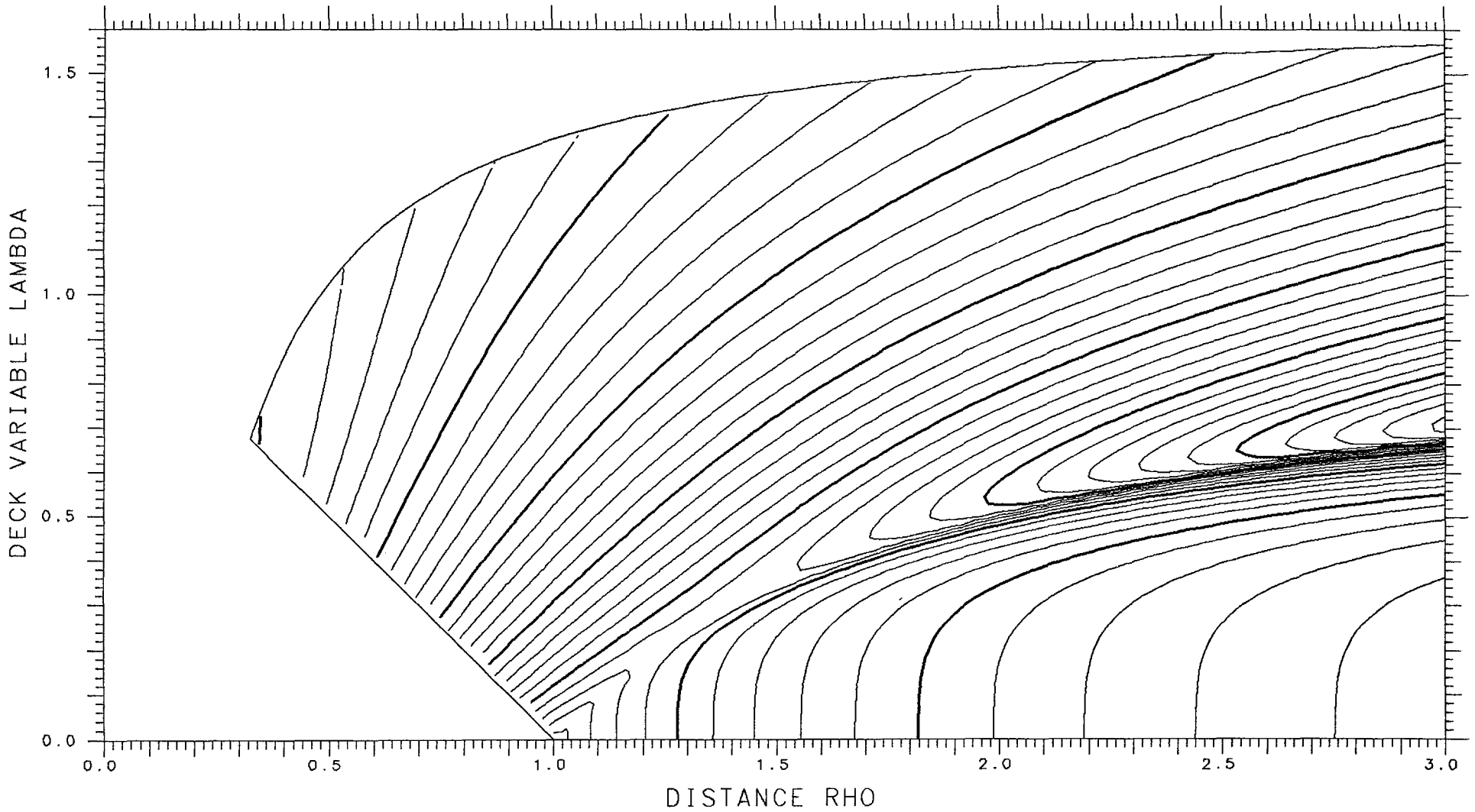

X= .925 ASYMMETRY DELTA= .425 FRACTIONAL= .9384

SPHERES -.05383 TANGENT .07598 LENGTH **11.155** ENERGY 709.11 SPACING .002

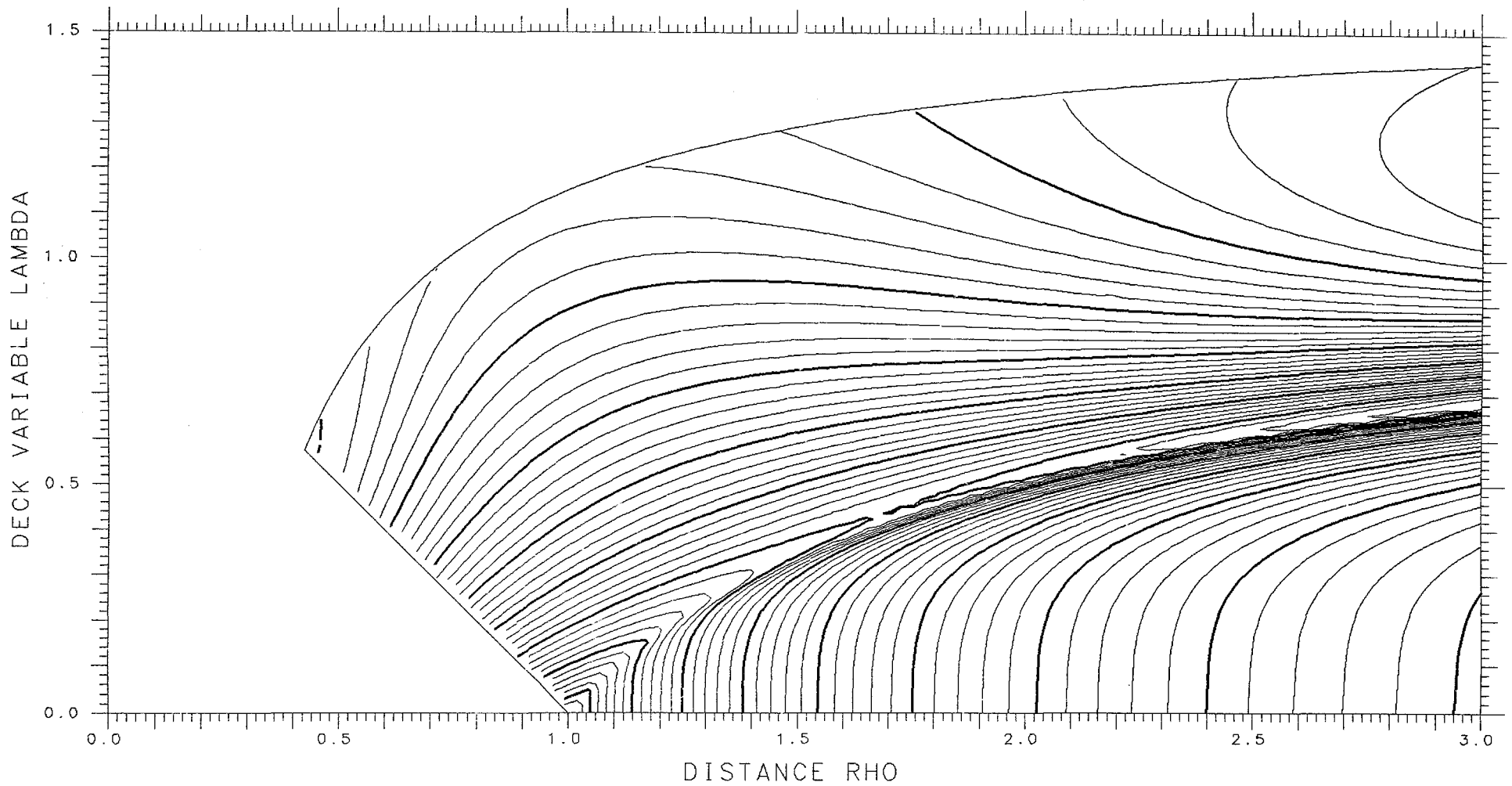

X= .450 ASYMMETRY DELTA= .350 FRACTIONAL= .8996

SPHERES .02193 TANGENT .11667 LENGTH 8.690 ENERGY 423.38 SPACING .005

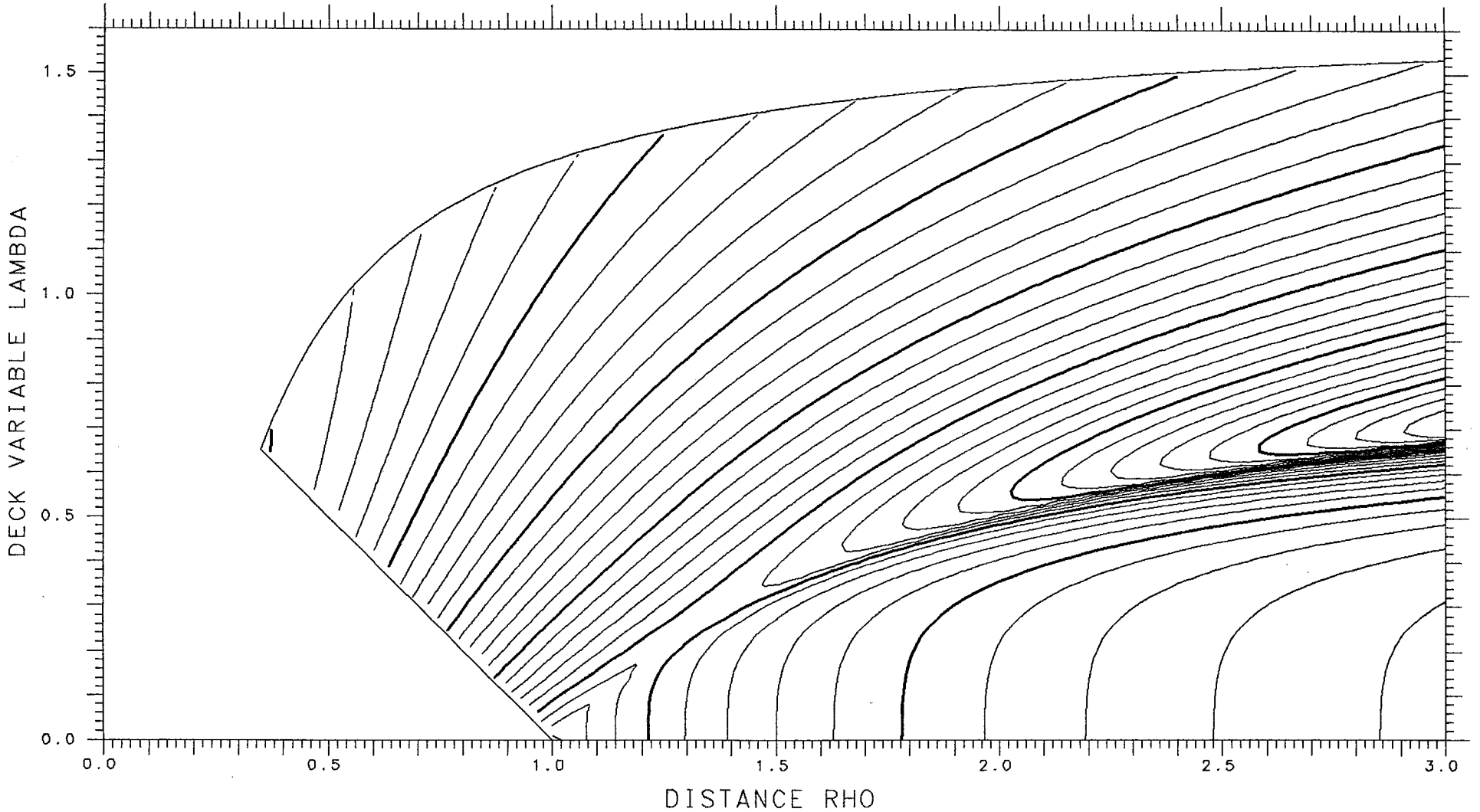

X= .925 ASYMMETRY DELTA= .400 FRACTIONAL= .9270

SPHERES -.07054 TANGENT .07920 LENGTH **11.308** ENERGY 709.11 SPACING .002

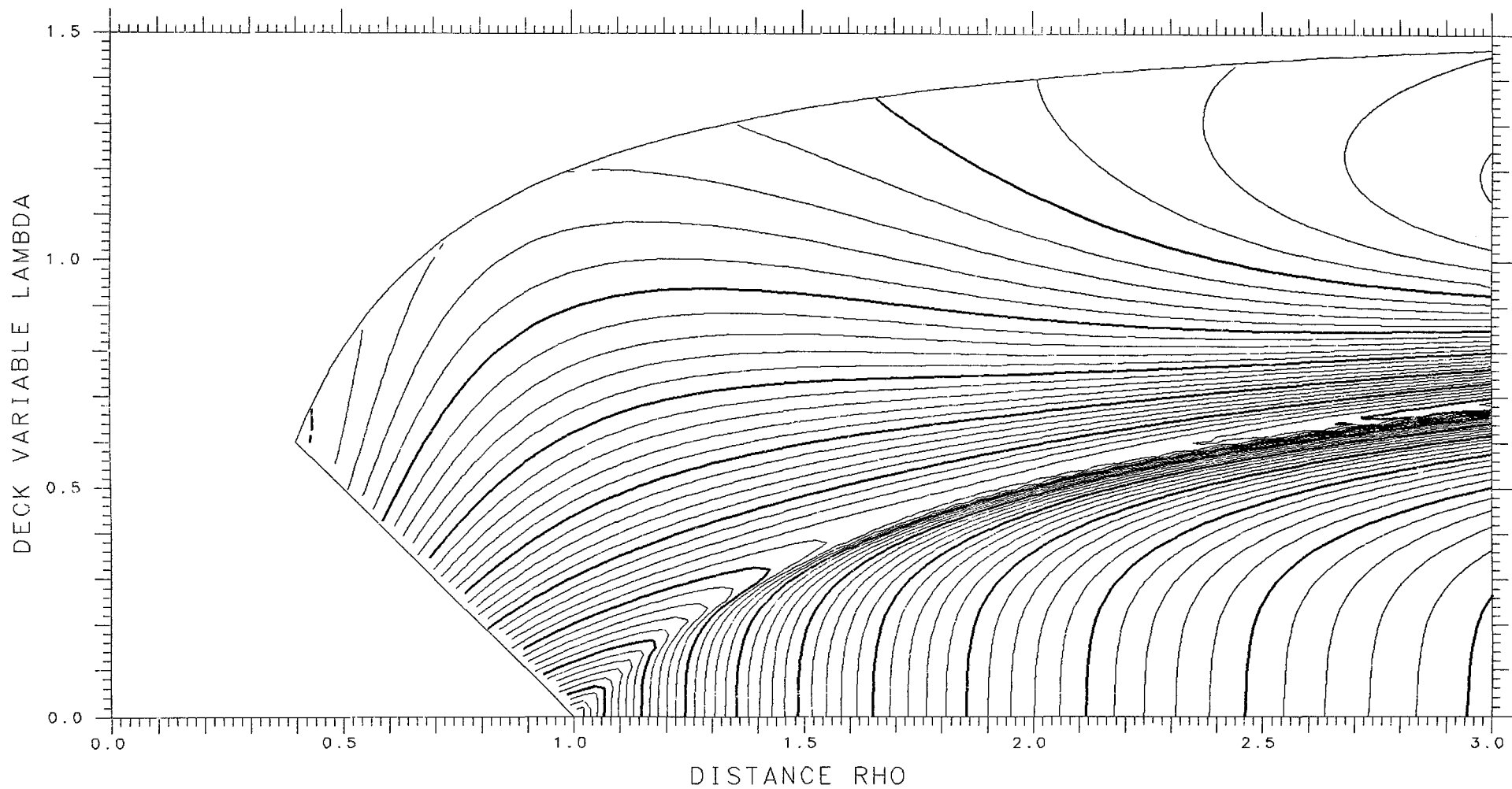

X= .450 ASYMMETRY DELTA= .375 FRACTIONAL= .9141

SPHERES .02650 TANGENT .10990 LENGTH 8.577 ENERGY 423.38 SPACING .005

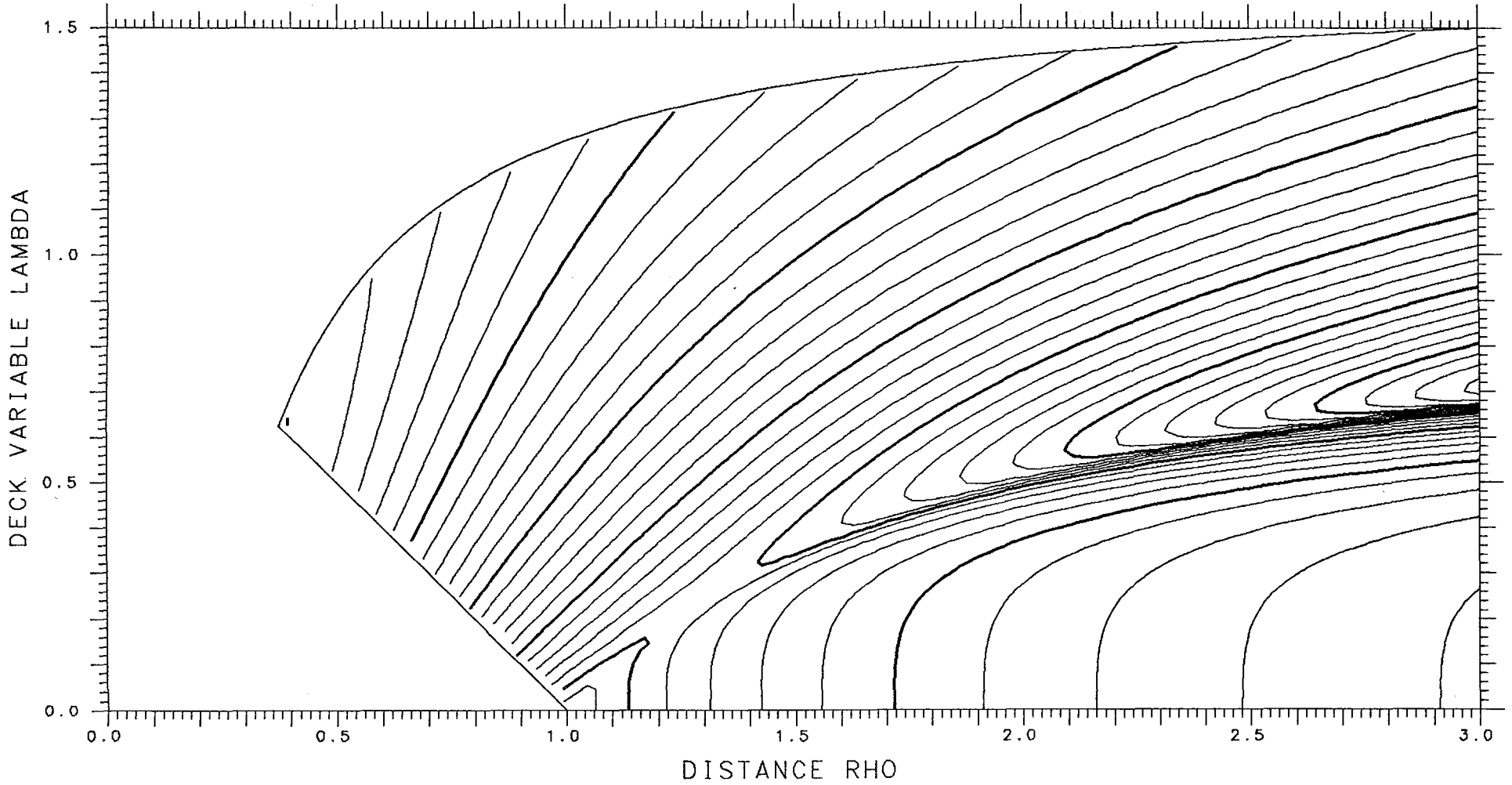

X= .925 ASYMMETRY DELTA= .375 FRACTIONAL= .9141

SPHERES -.08963 TANGENT .08179 LENGTH 11.460 ENERGY 709.11 SPACING .002

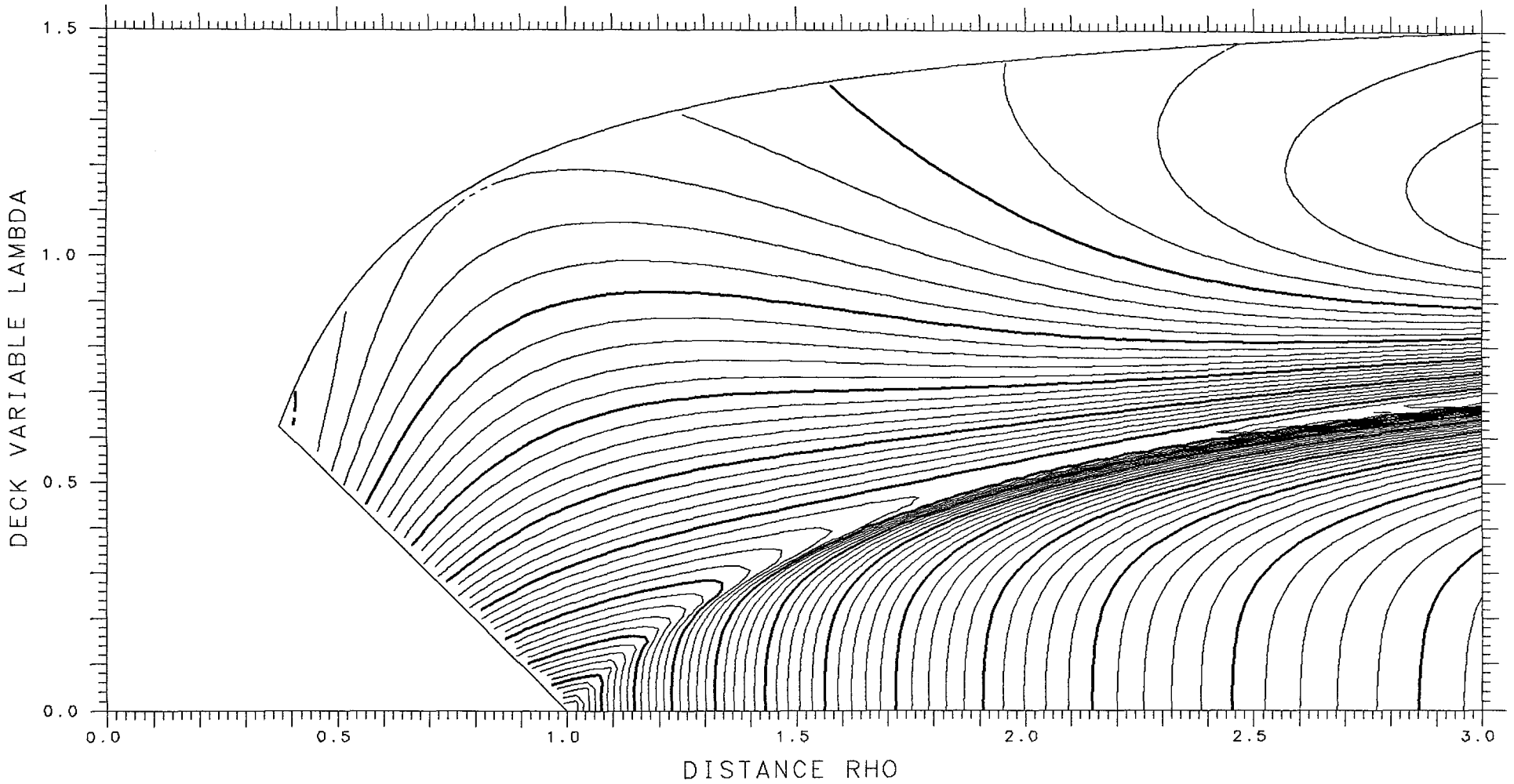

X= .450 ASYMMETRY DELTA= .400 FRACTIONAL= .9270

SPHERES .03006 TANGENT .10291 LENGTH 8.464 ENERGY 423.38 SPACING .005

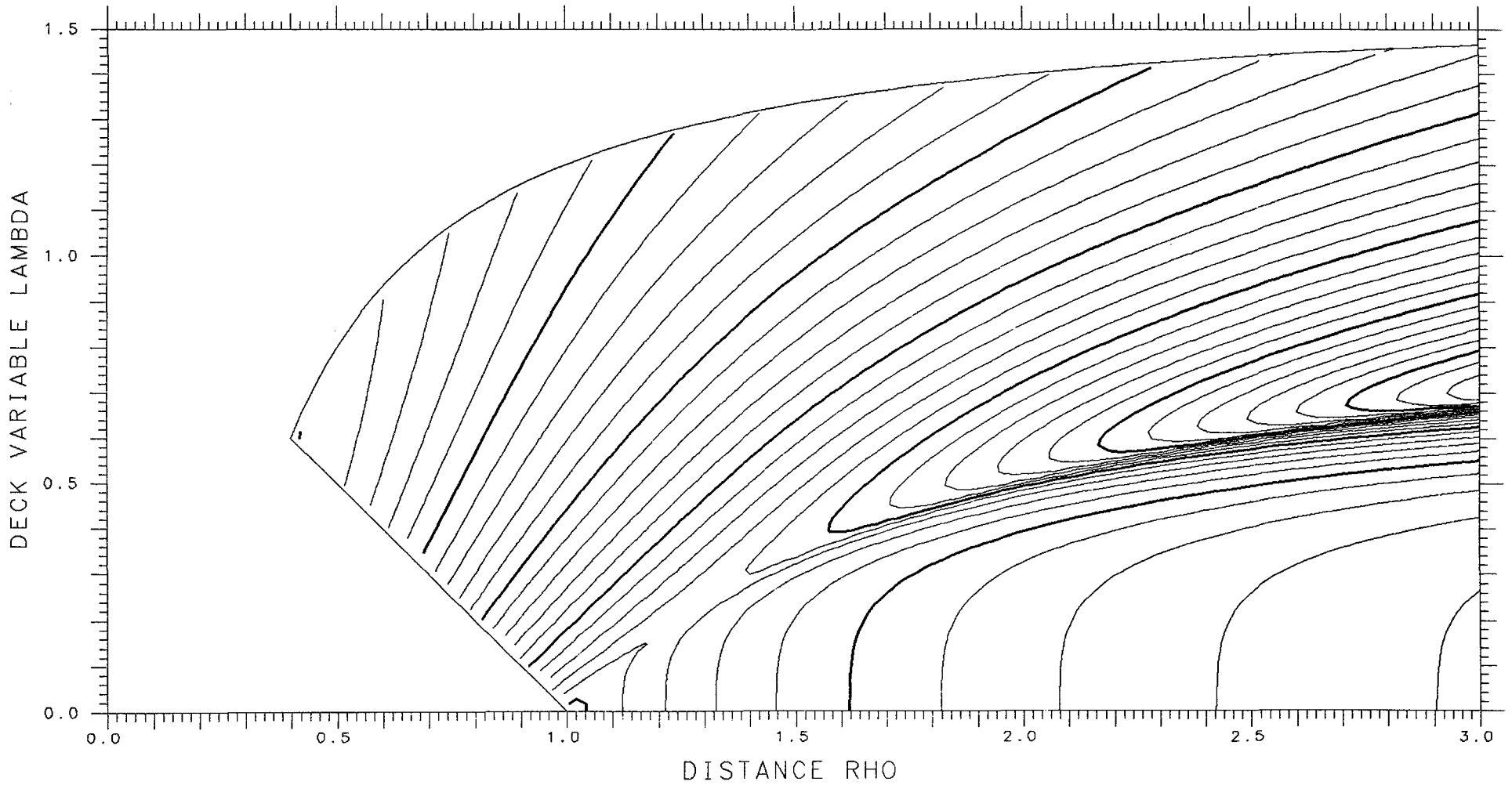

X= .925 ASYMMETRY DELTA= .350 FRACTIONAL= .8996

SPHERES -.11107 TANGENT .08368 LENGTH 11.610 ENERGY 709.11 SPACING .002

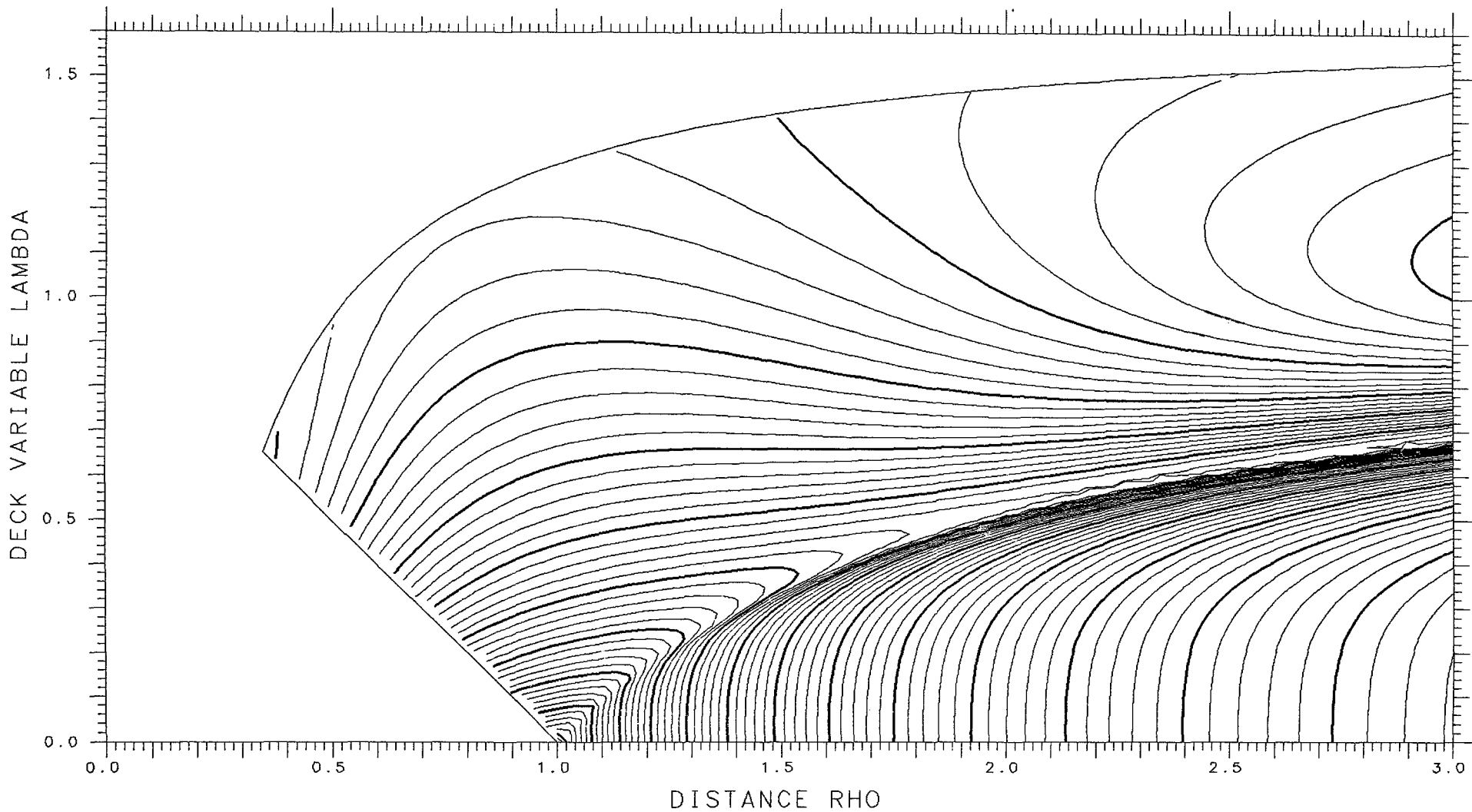

X= .450 ASYMMETRY DELTA= .425 FRACTIONAL= .9384

SPHERES .03262 TANGENT .09577 LENGTH 8.349 ENERGY 423.38 SPACING .005

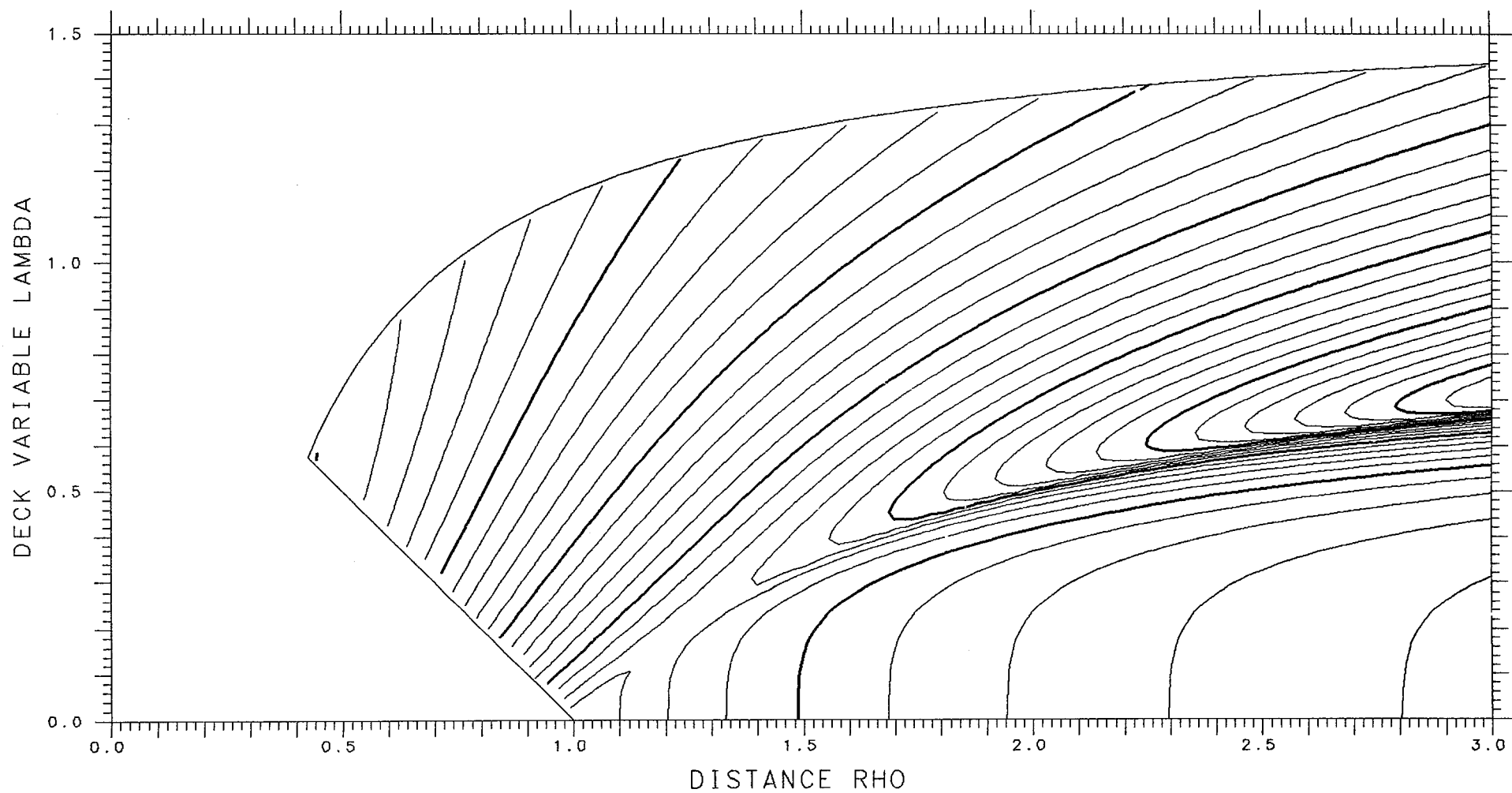

X= .925 ASYMMETRY DELTA= .325 FRACTIONAL= .8832

SPHERES -.13477 TANGENT .08481 LENGTH 11.757 ENERGY 709.11 SPACING .002

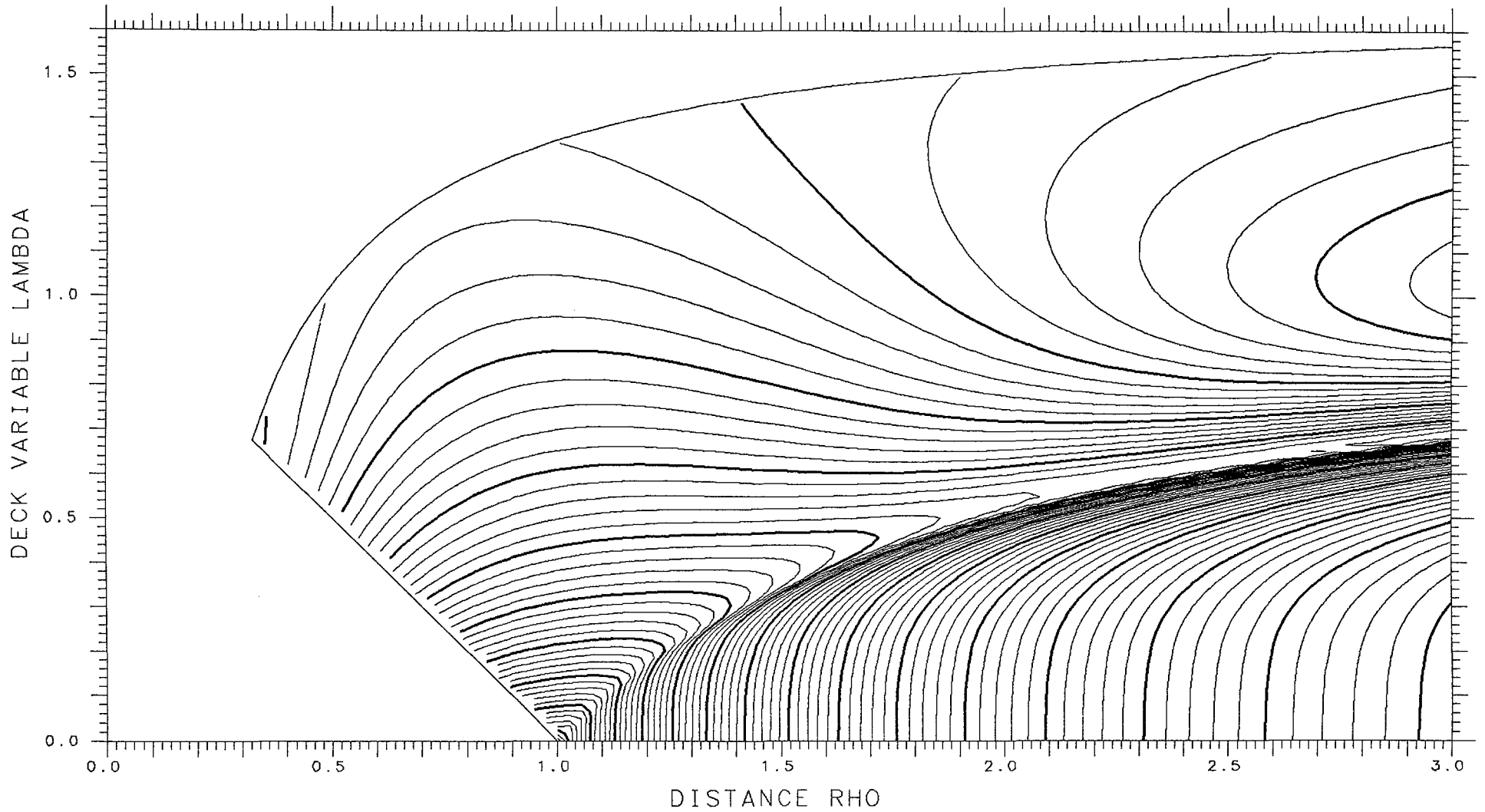

X= .450 ASYMMETRY DELTA= .450 FRACTIONAL= .9483

SPHERES .03425 TANGENT .08857 LENGTH 8.234 ENERGY 423.38 SPACING .005

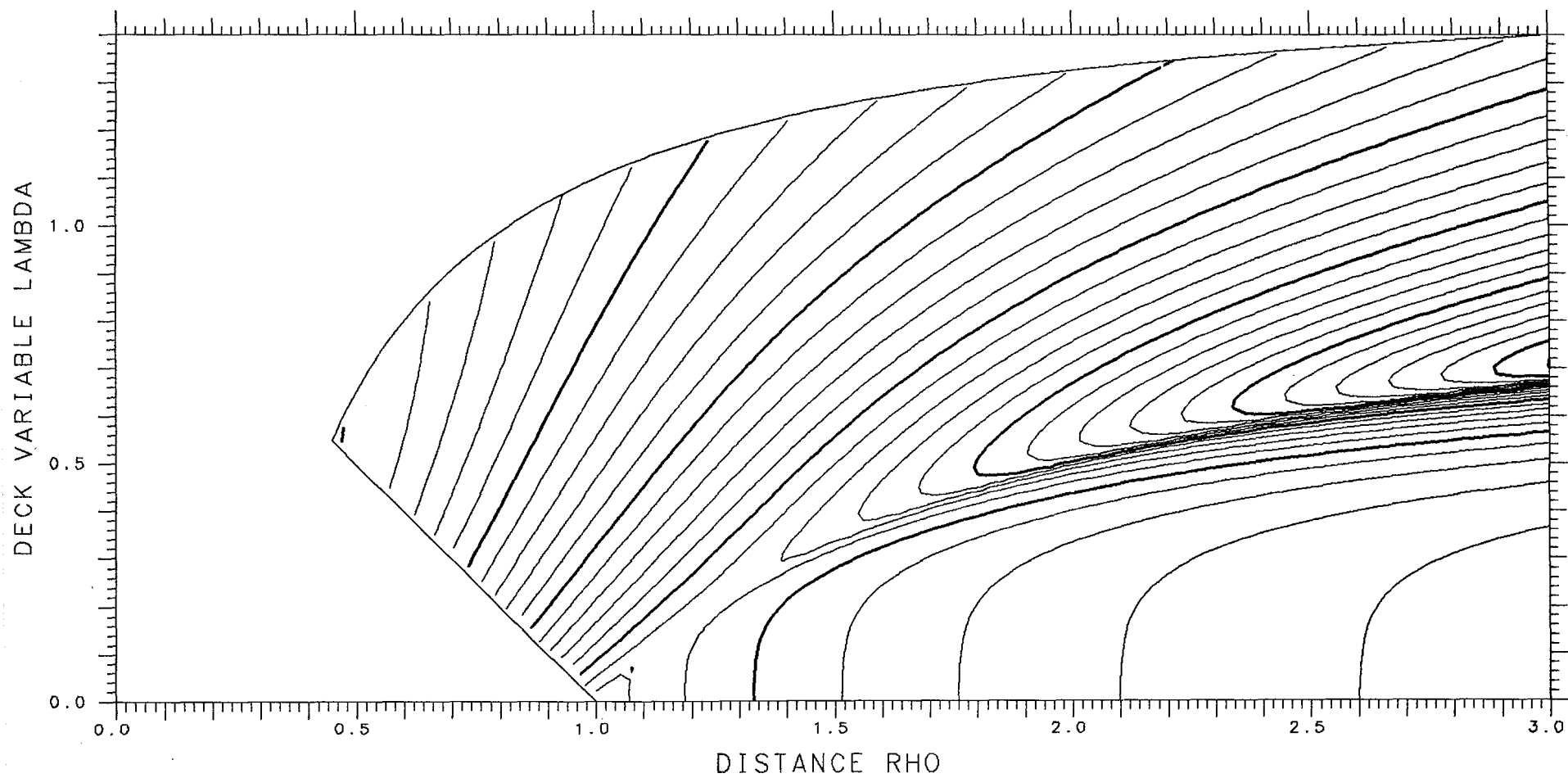

X= .925 ASYMMETRY DELTA= .300 FRACTIONAL= .8650

SPHERES -.16055 TANGENT .08514 LENGTH 11.900 ENERGY 709.11 SPACING .002

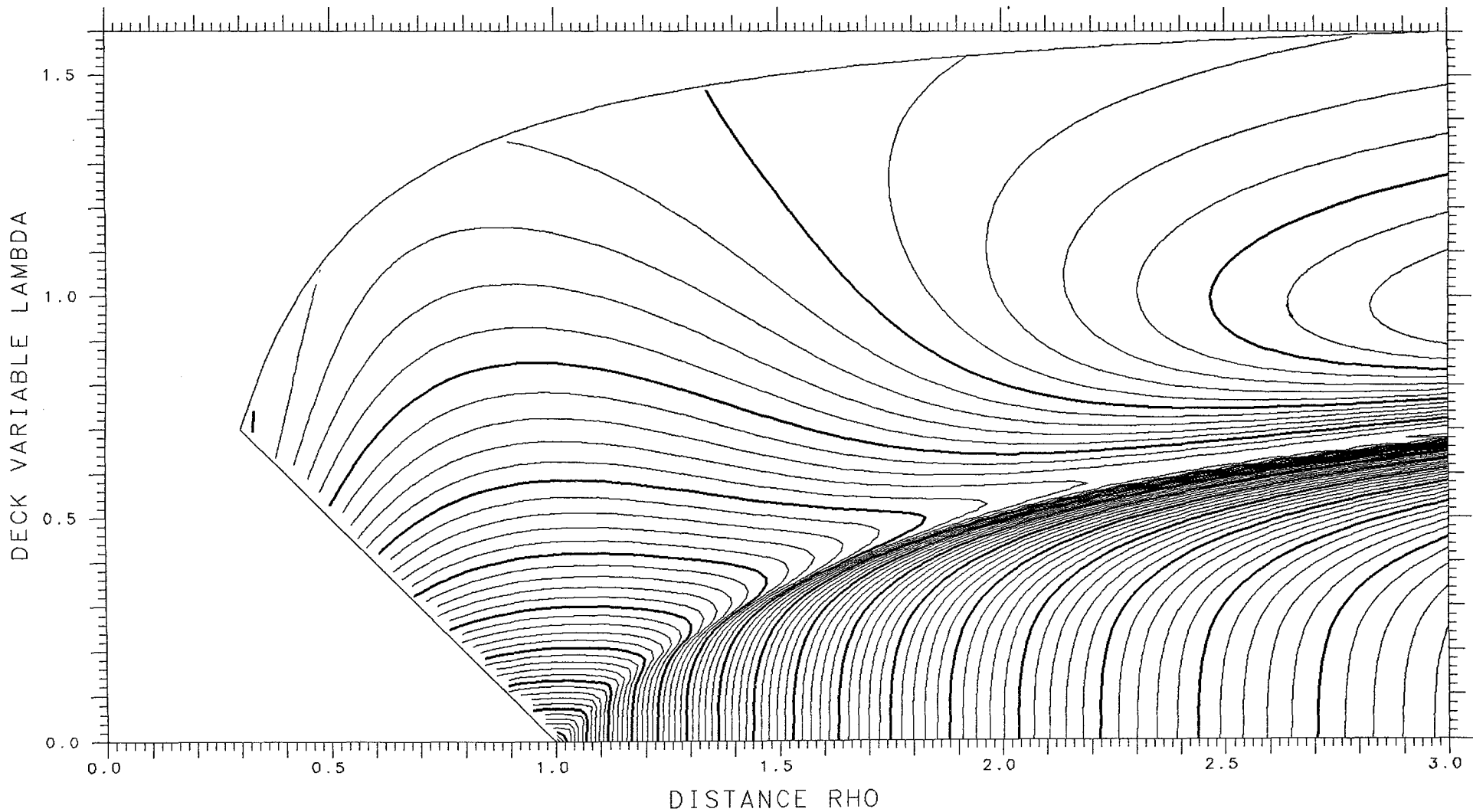

X= .450 ASYMMETRY DELTA= .475 FRACTIONAL= .9569

SPHERES .03503 TANGENT .08138 LENGTH 8.118 ENERGY 423.38 SPACING .005

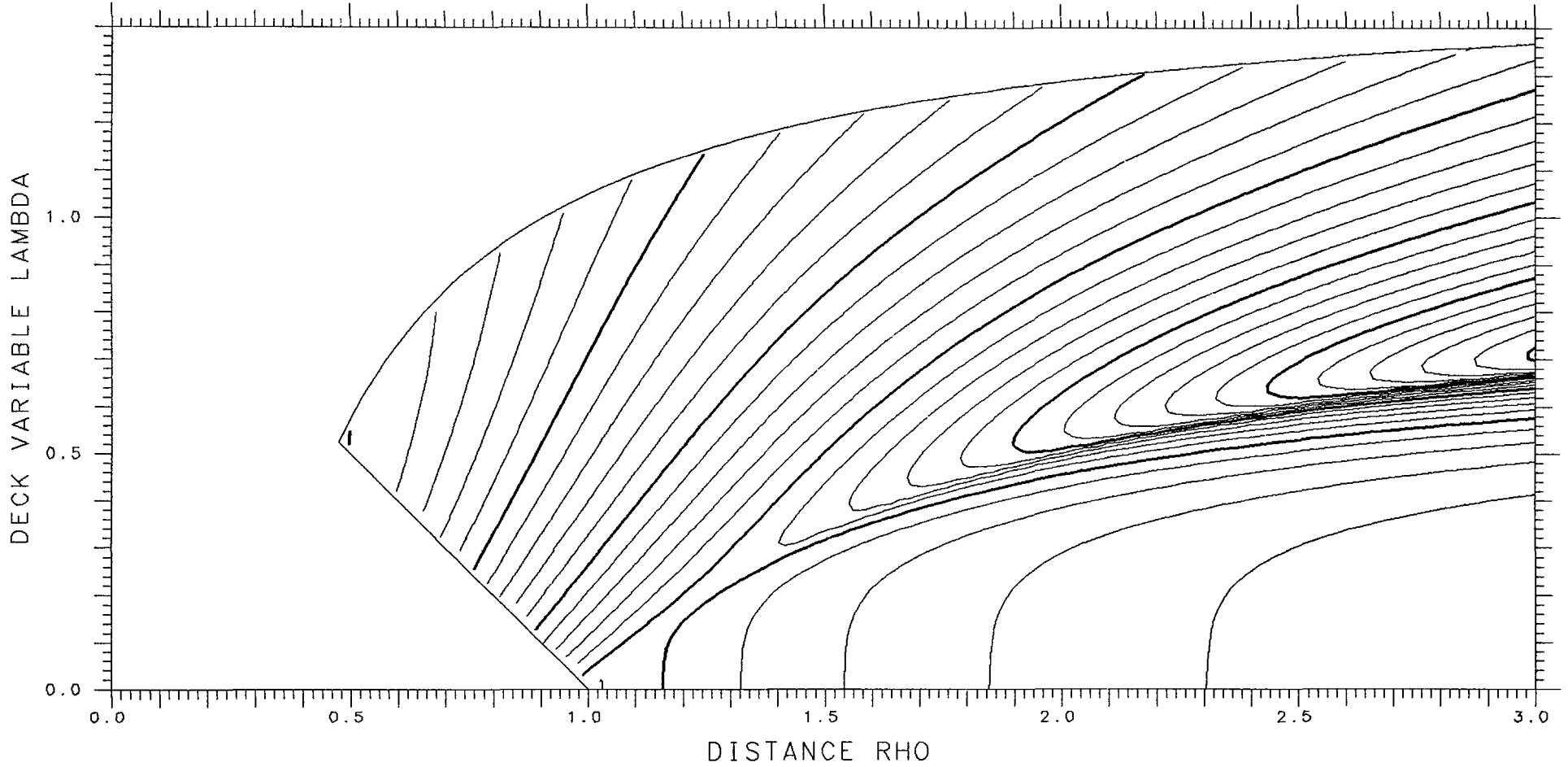

X= .925 ASYMMETRY DELTA= .275 FRACTIONAL= .8447

SPHERES -.18809 TANGENT .08469 LENGTH 12.038 ENERGY 709.11 SPACING .002

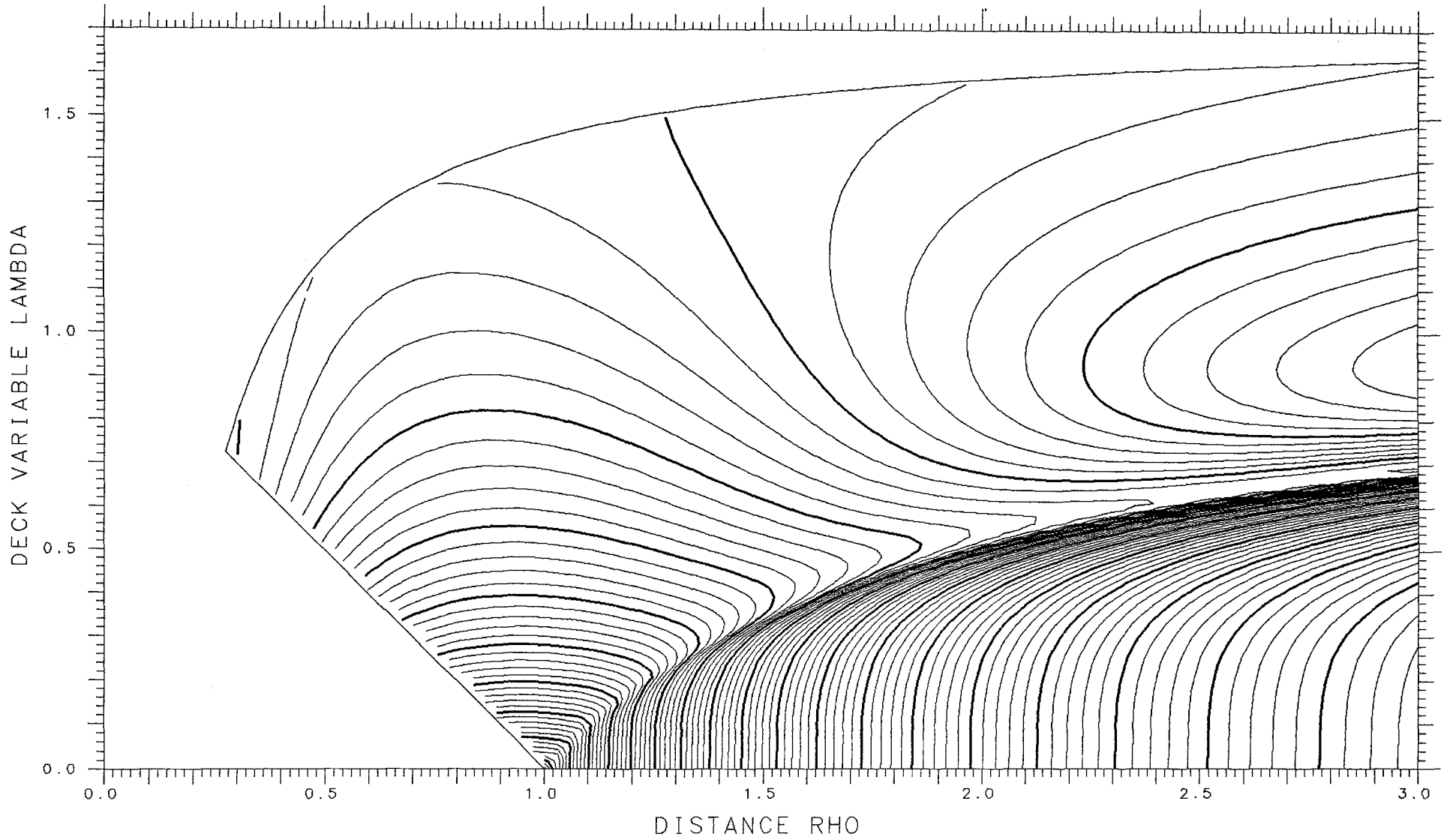

X= .450 ASYMMETRY DELTA= .500 FRACTIONAL= .9643

SPHERES .03505 TANGENT .07427 LENGTH 8.004 ENERGY 423.38 SPACING .005

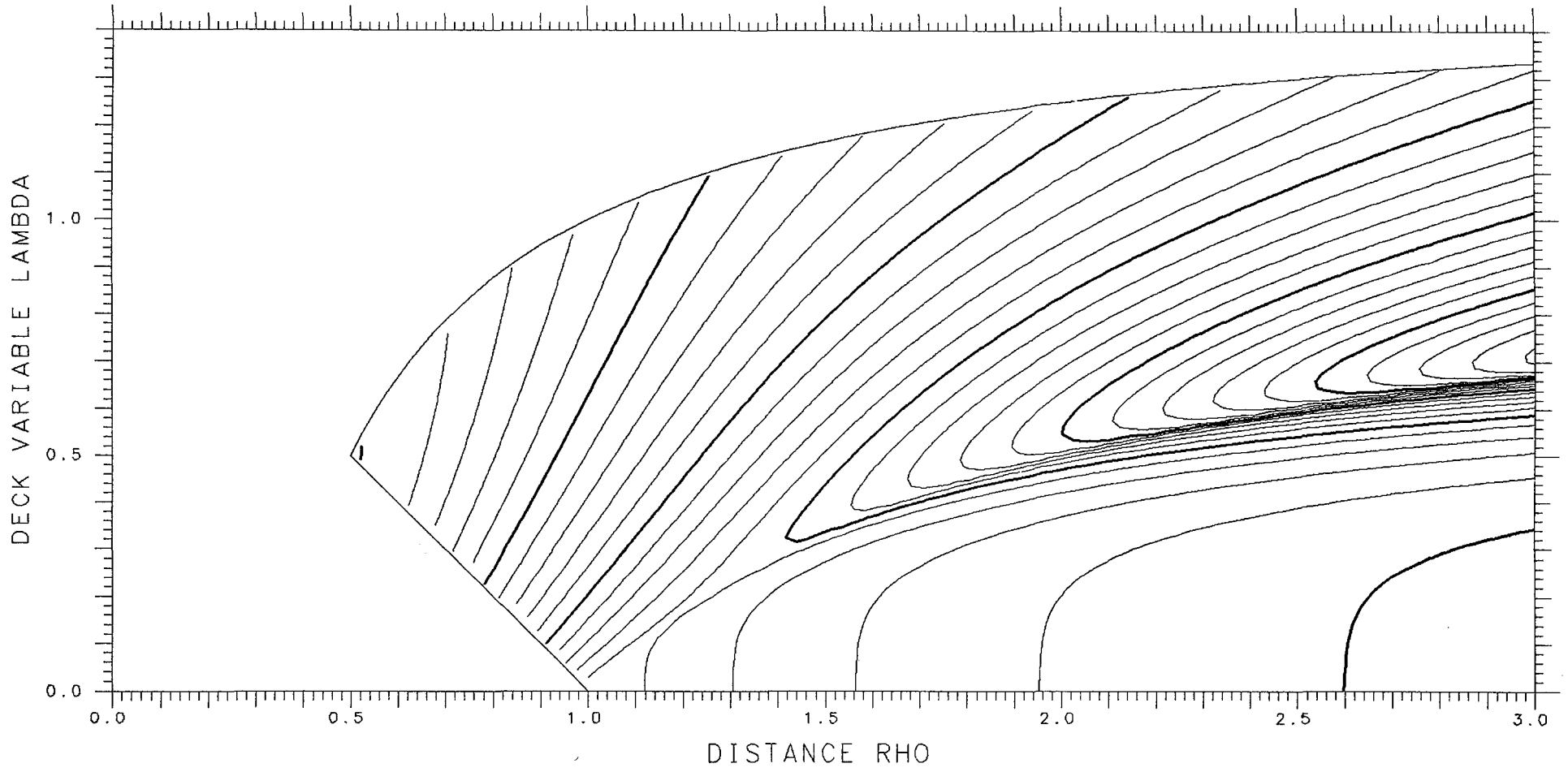

X = .925 ASYMMETRY DELTA = .250 FRACTIONAL = .8224

SPHERES - .21699 TANGENT .08348 LENGTH **12.169** ENERGY 709.11 SPACING .002

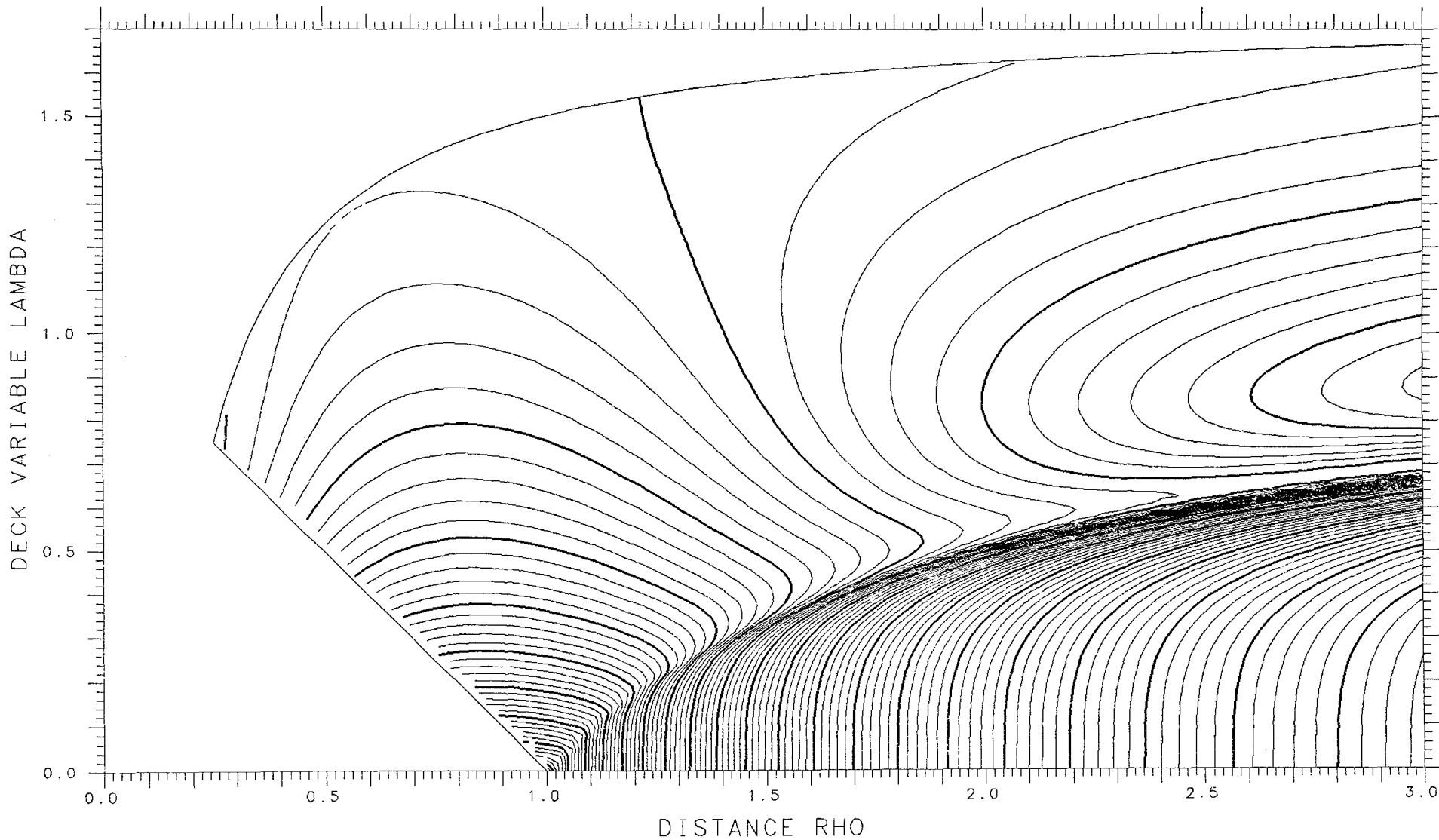

X= .500

ASYMMETRY DELTA=0.

FRACTIONAL= .5000

SPHERES -.11012

TANGENT .15237

LENGTH 10.062

ENERGY 457.52

SPACING .005

SADDLE .09669

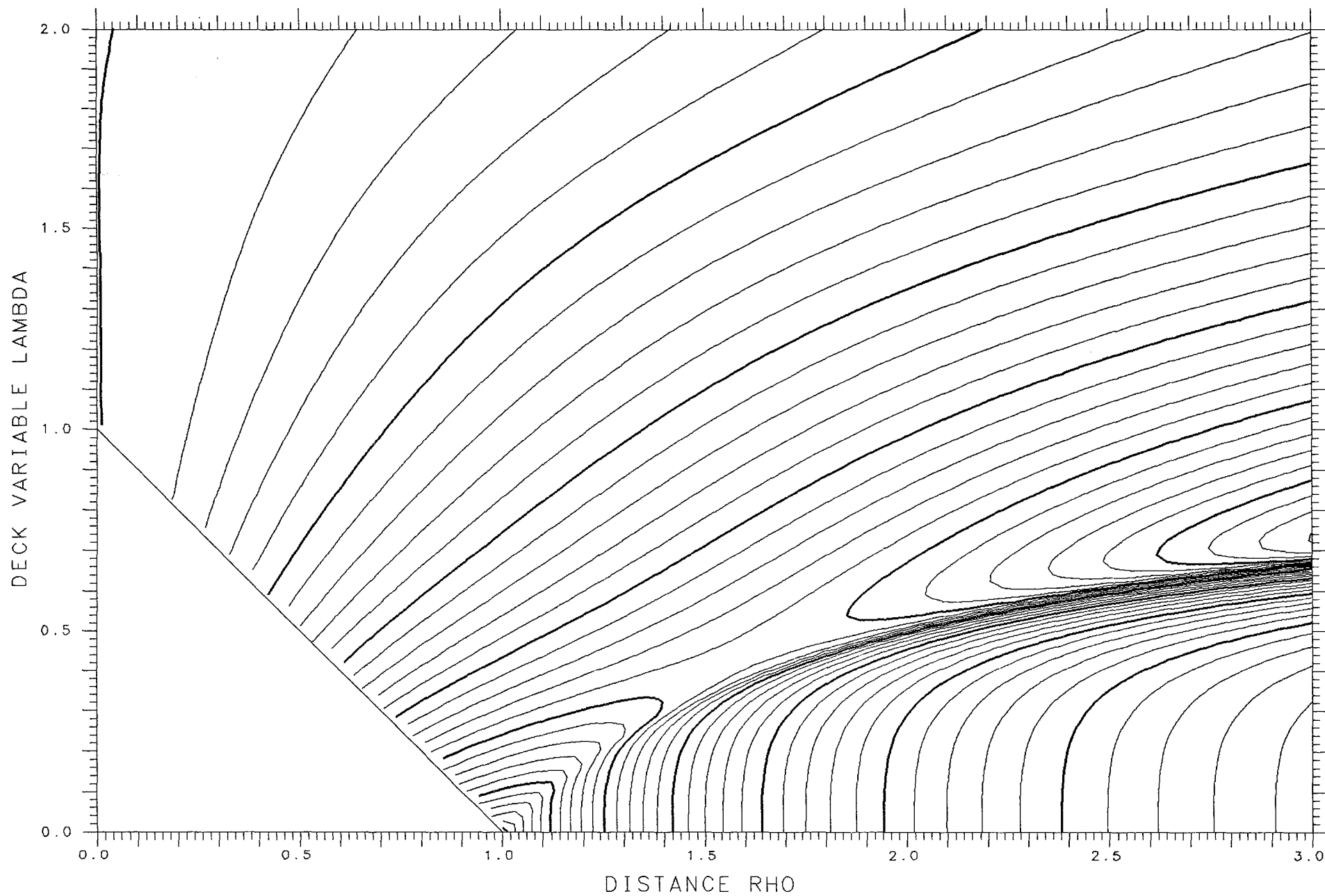

X= .925 ASYMMETRY DELTA= .225 FRACTIONAL= .7979

SPHERES -.24669 TANGENT .08159 LENGTH **12.293** ENERGY 709.11 SPACING .002

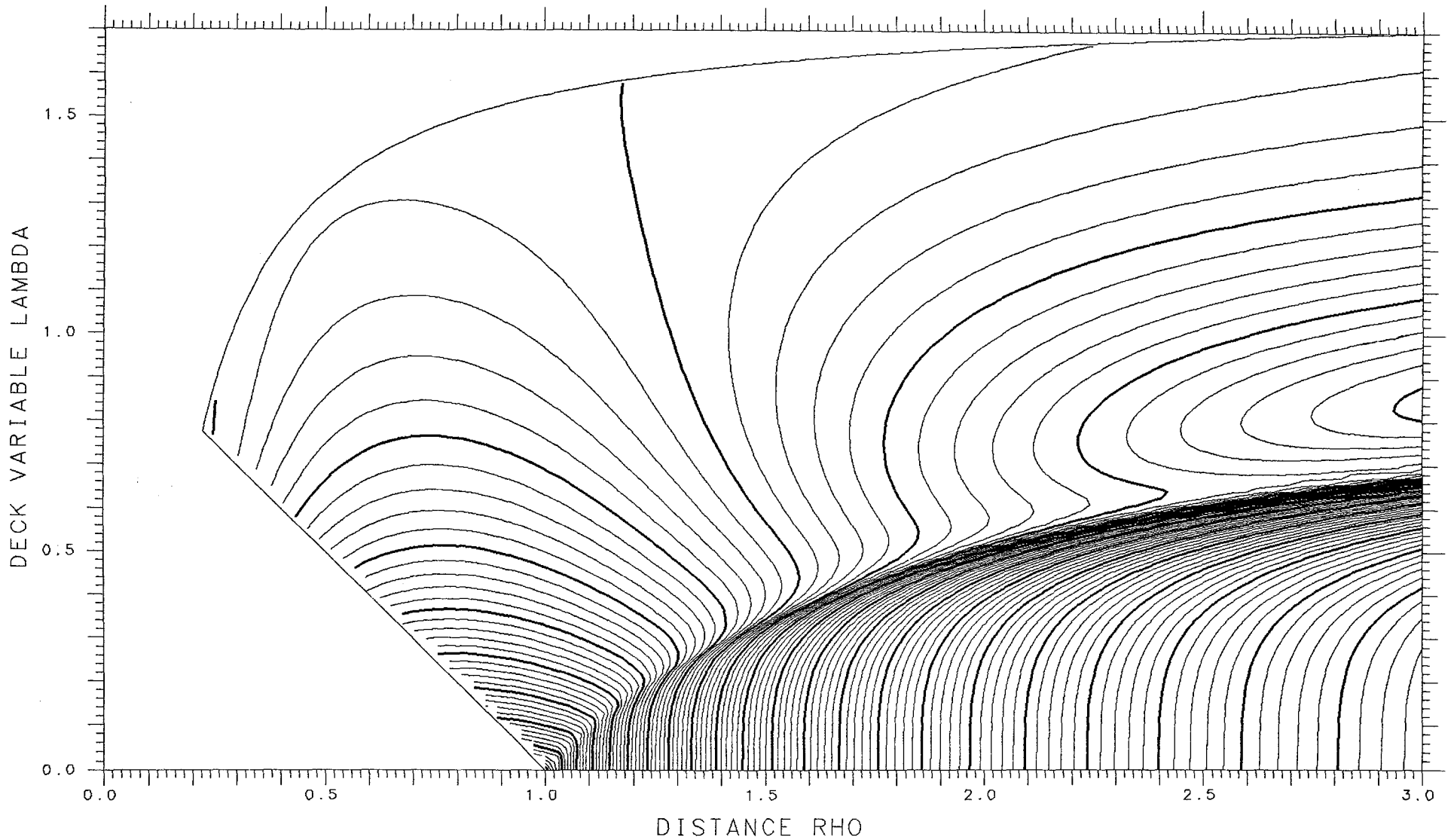

X= .500 ASYMMETRY DELTA= .025 FRACTIONAL= .5374

SPHERES -.10894 TANGENT .15223 LENGTH 10.056 ENERGY 457.52 SPACING .005 SADDLE .09690

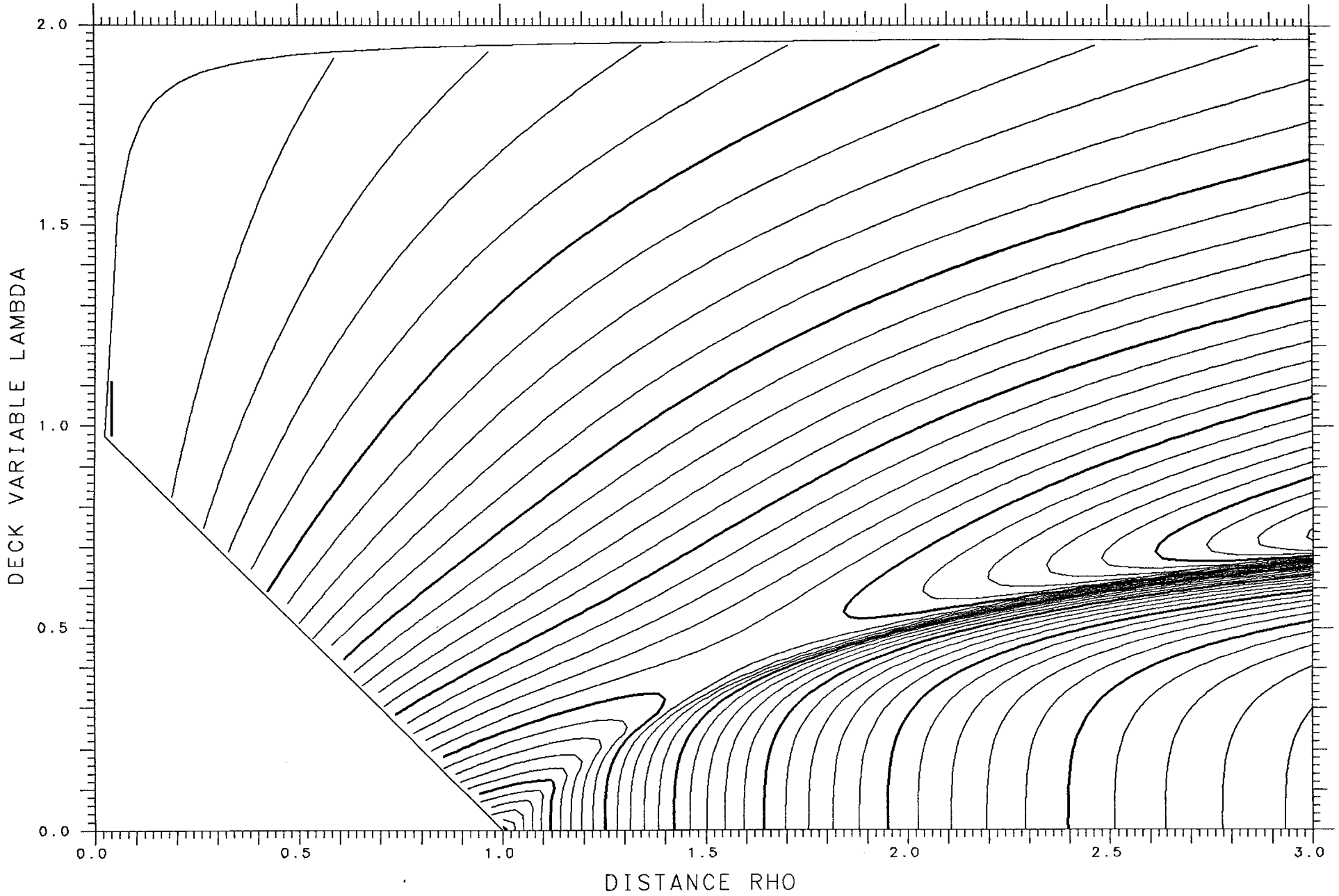

X= .925 ASYMMETRY DELTA= .200 FRACTIONAL= .7714

SPHERES -.27654 TANGENT .07914 LENGTH 12.409 ENERGY 709.11 SPACING .002

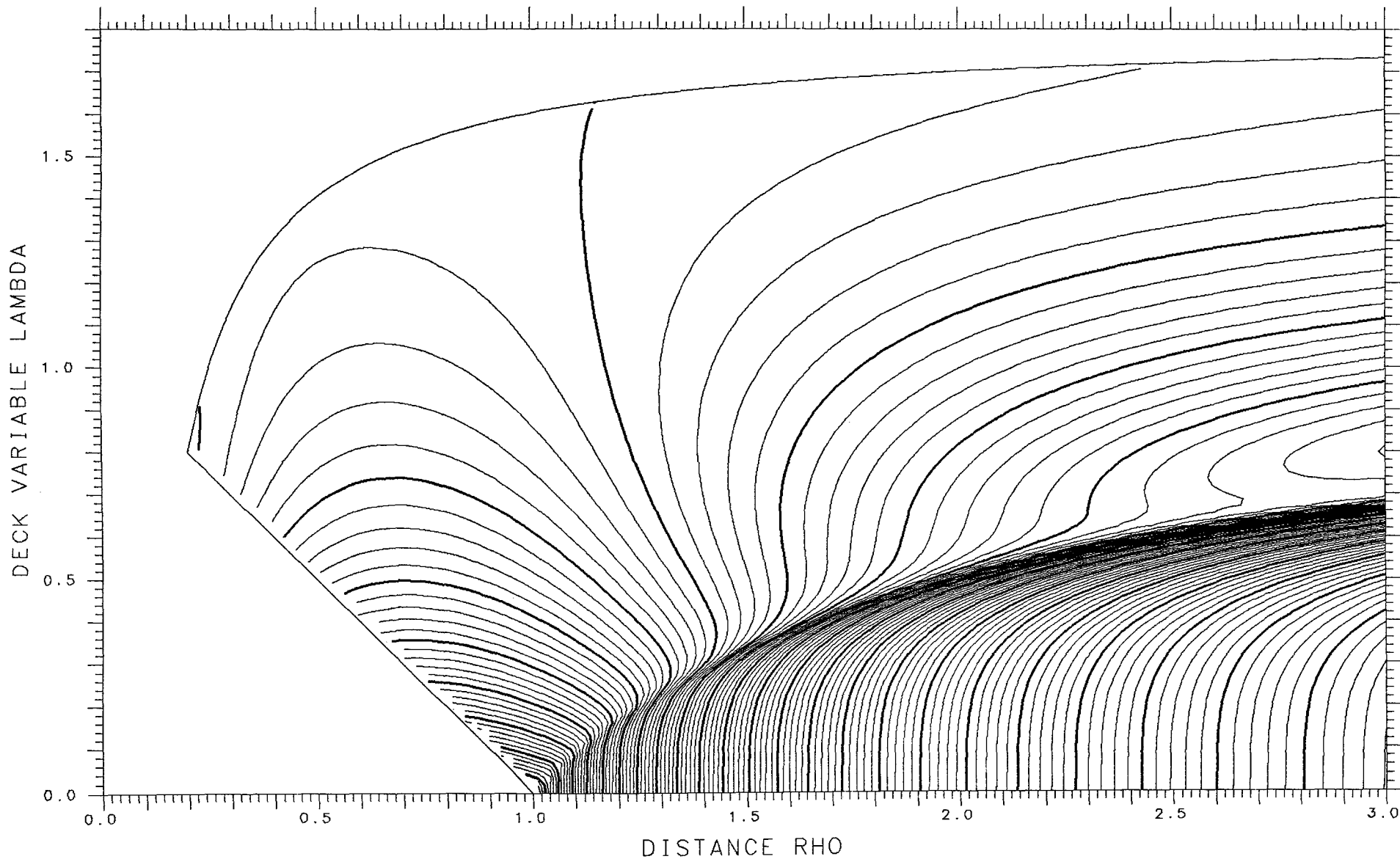

X= .500 ASYMMETRY DELTA= .050 FRACTIONAL= .5745

SPHERES -.10547 TANGENT .15183 LENGTH 10.037 ENERGY 457.52 SPACING .005 SADDLE .09750

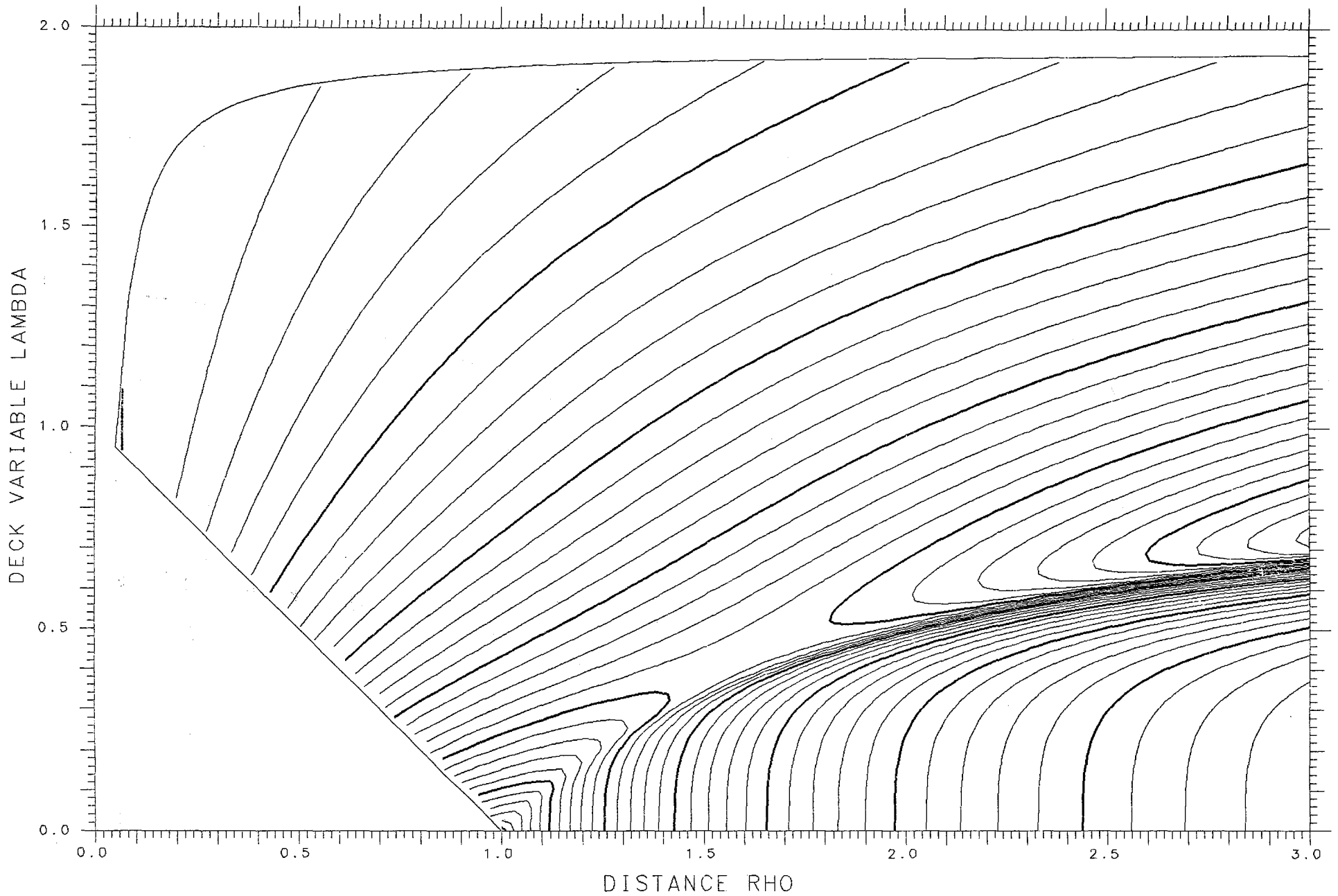

X= .925 ASYMMETRY DELTA= .175 FRACTIONAL= .7429

SPHERES -.30579 TANGENT .07627 LENGTH 12.515 ENERGY 709.11 SPACING .002

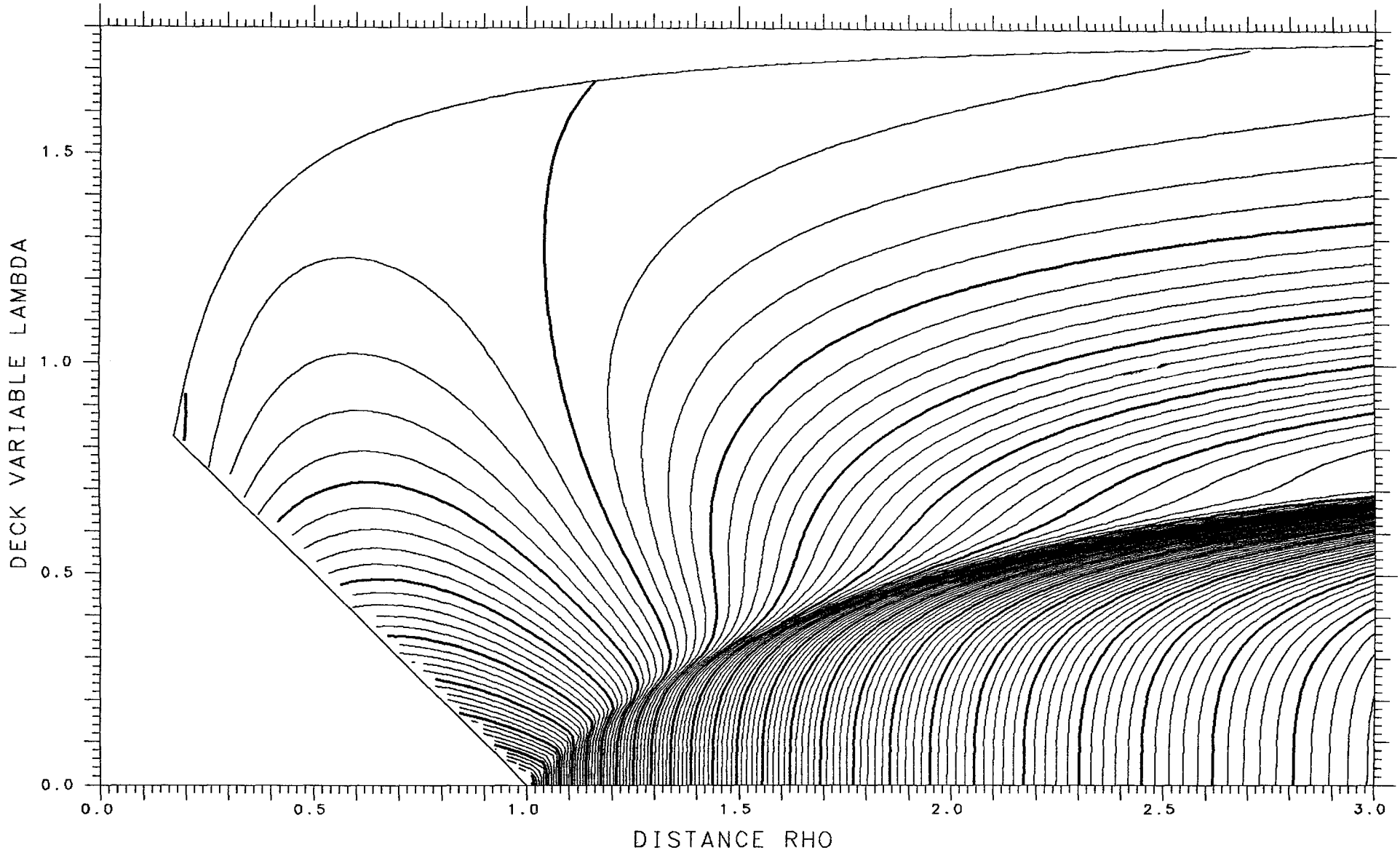

X= .500 ASYMMETRY DELTA= .075 FRACTIONAL= .6108

SPHERES -.09986 TANGENT .15112 LENGTH 10.006 ENERGY 457.52 SPACING .005 SADDLE .09844

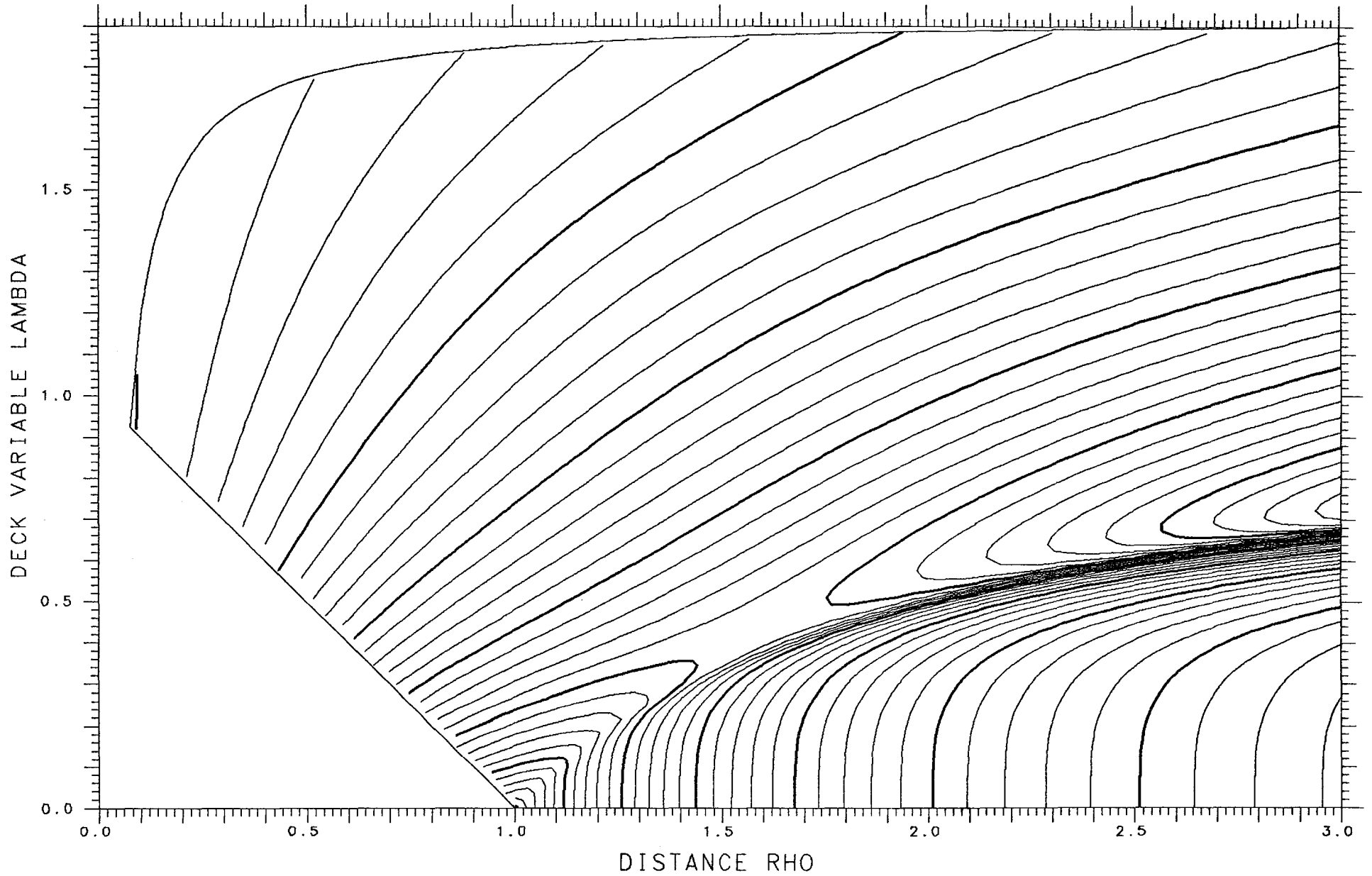

X= .925 ASYMMETRY DELTA= .150 FRACTIONAL= .7124

SPHERES -.33359 TANGENT .07317 LENGTH 12.609 ENERGY 709.11 SPACING .002

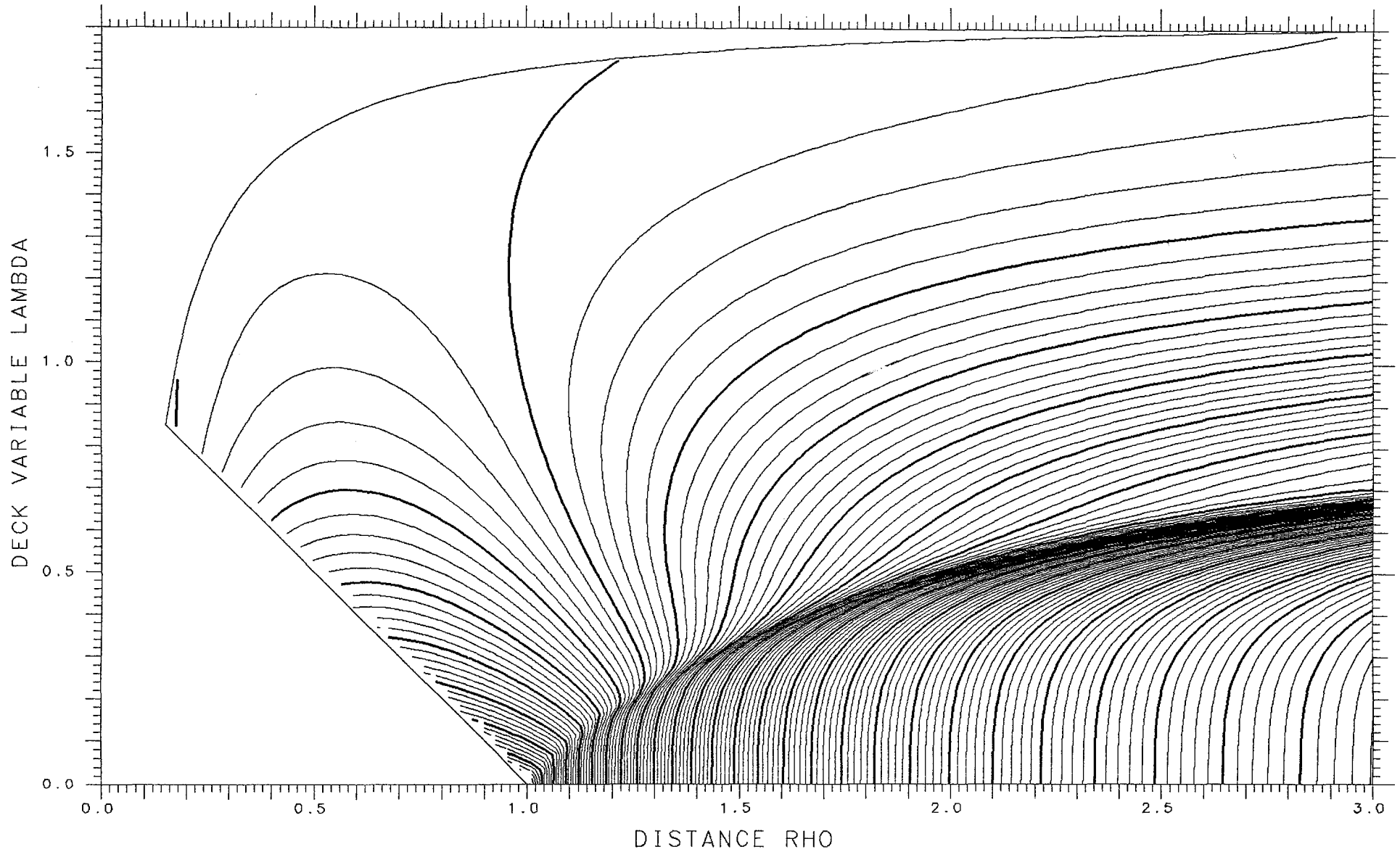

X= .500 ASYMMETRY DELTA= .100 FRACTIONAL= .6461

SPHERES -.09236 TANGENT .15008 LENGTH 9.964 ENERGY 457.52 SPACING .005 SADDLE .09964

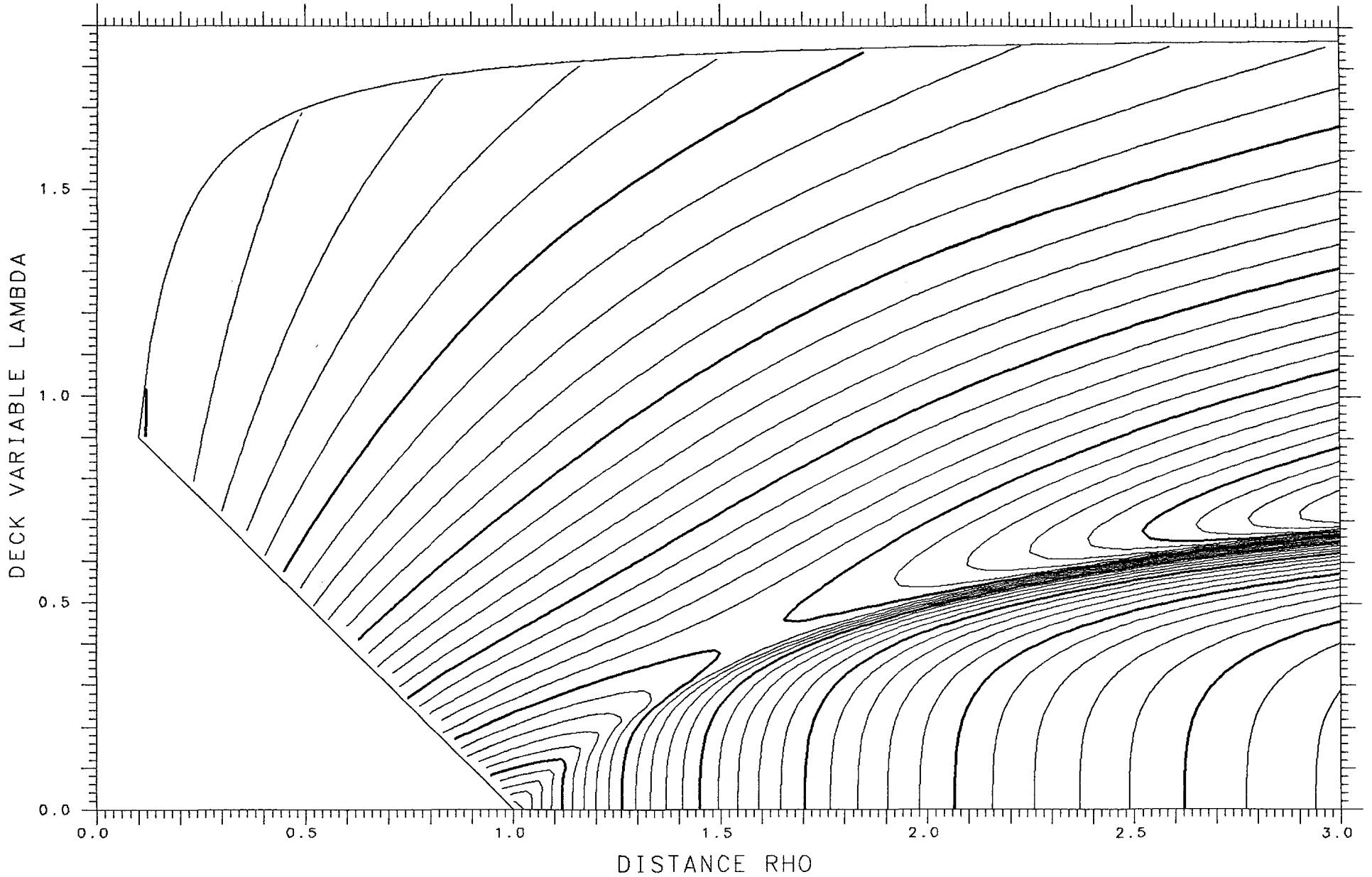

X= .925

ASYMMETRY DELTA= .125

FRACTIONAL= .6800

SPHERES -.35909

TANGENT .07005

LENGTH 12.691

ENERGY 709.11

SPACING .002

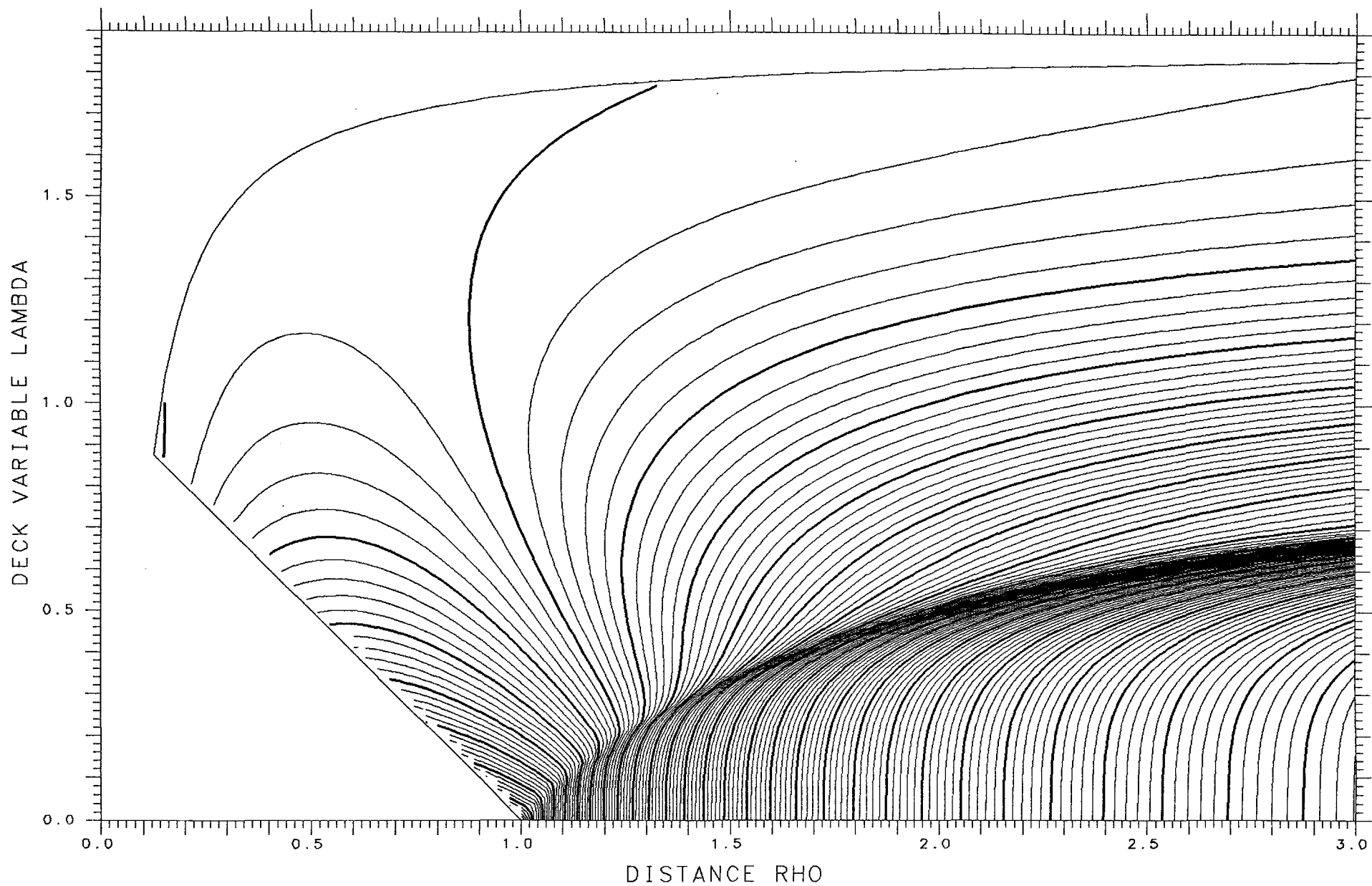

X= .500 ASYMMETRY DELTA= .125 FRACTIONAL= .6800

SPHERES -.08332 TANGENT .14865 LENGTH 9.910 ENERGY 457.52 SPACING .005 SADDLE .10097

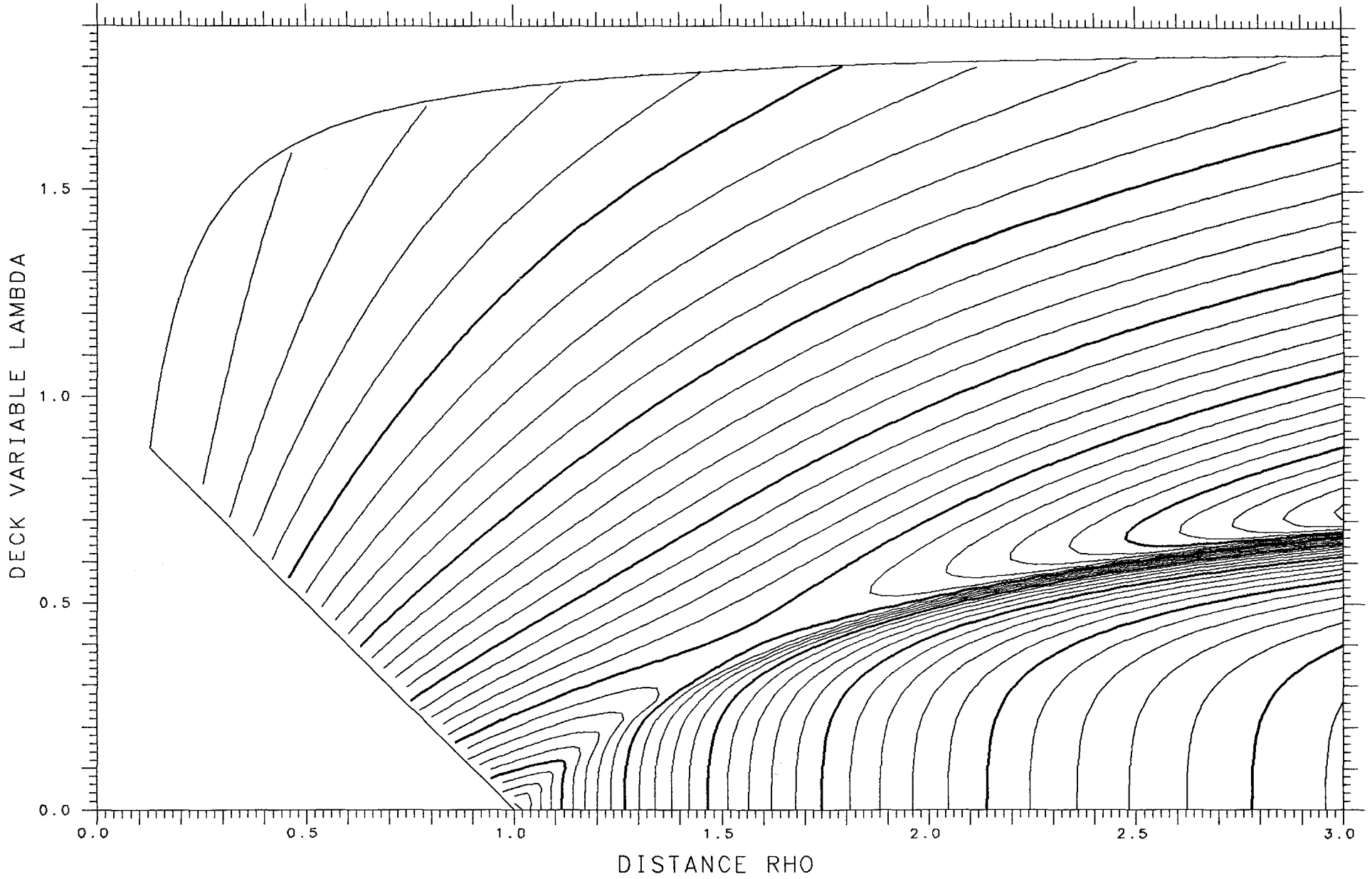

X= .925

ASYMMETRY DELTA= .100

FRACTIONAL= .6461

SPHERES -.38141

TANGENT .06711

LENGTH 12.760

ENERGY 709.11

SPACING .002

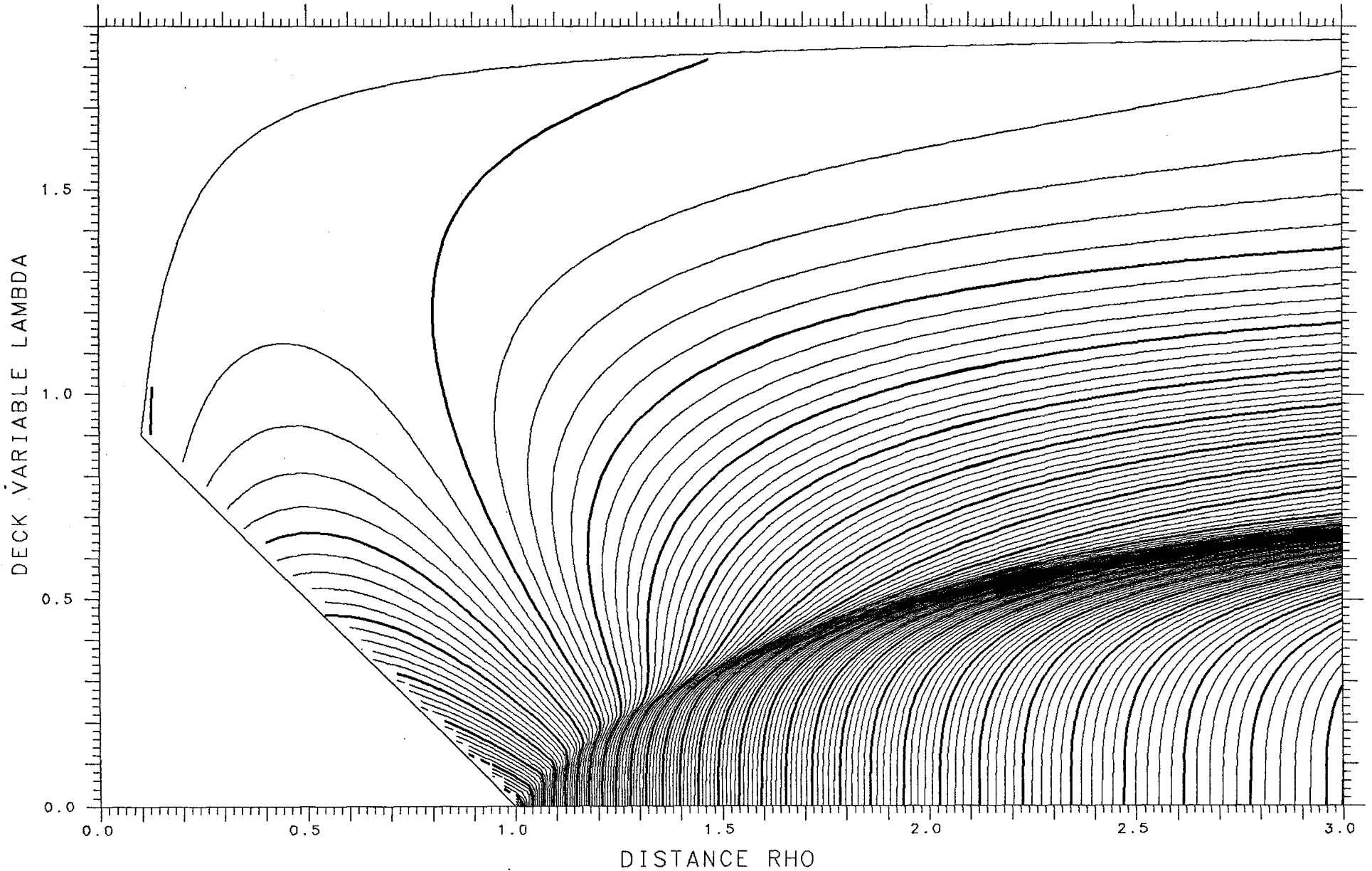

X= .500 ASYMMETRY DELTA= .150 FRACTIONAL= .7124

SPHERES -.07309 TANGENT .14678 LENGTH 9.846 ENERGY 457.52 SPACING .005 SADDLE .10230

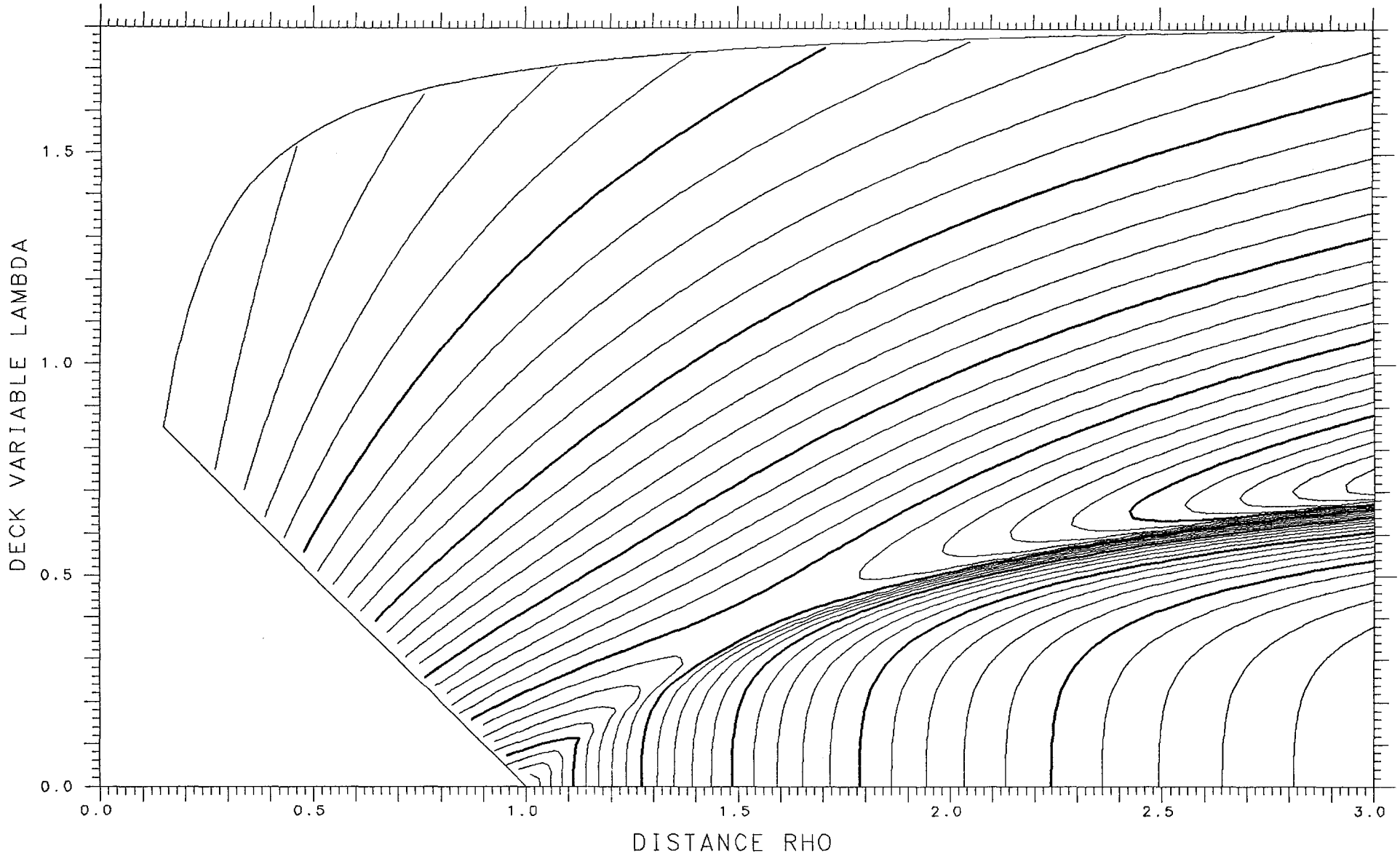

X= .925 ASYMMETRY DELTA= .075 FRACTIONAL= .6108

SPHERES -.39974 TANGENT .06457 LENGTH 12.815 ENERGY 709.11 SPACING .002

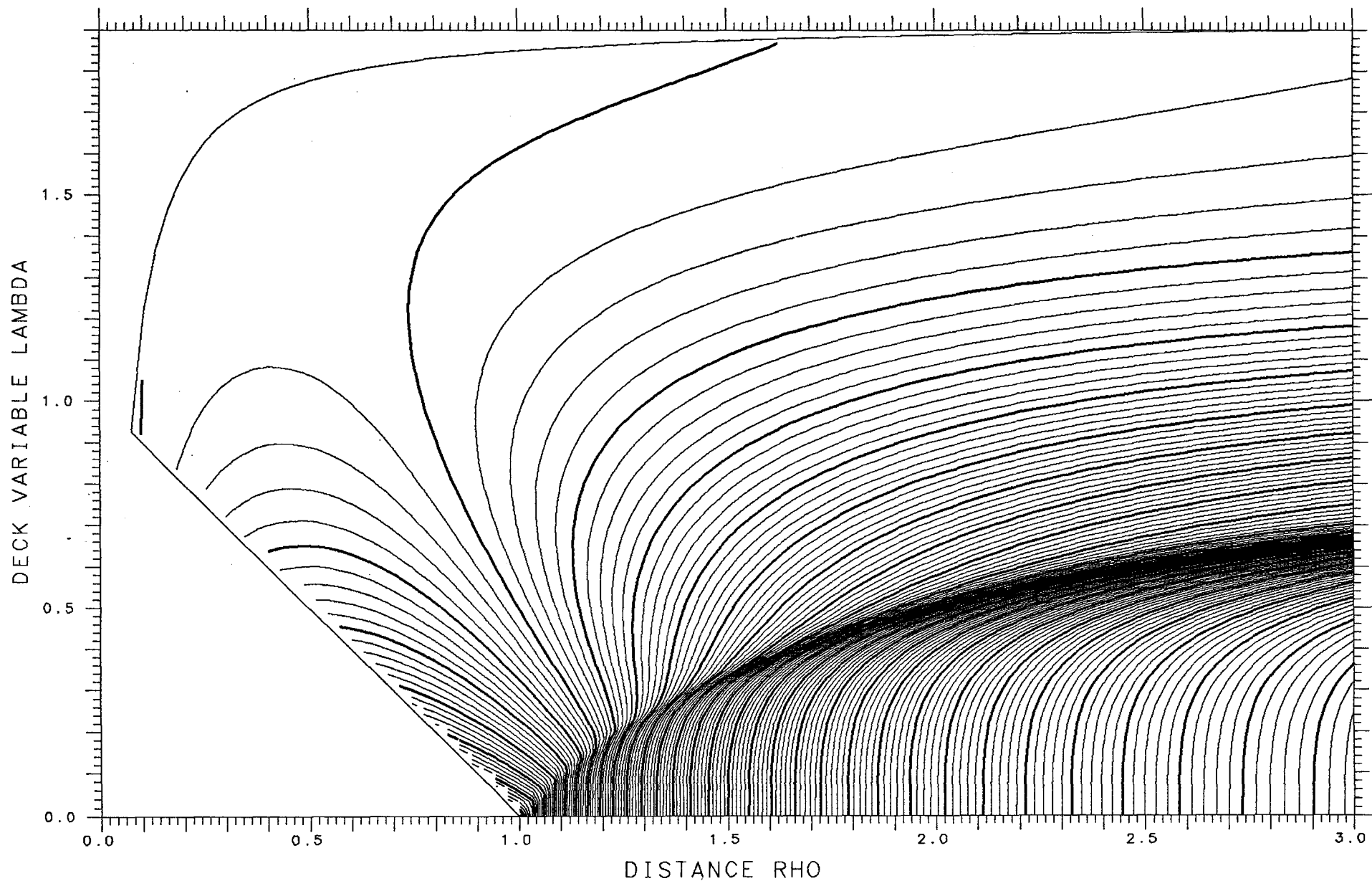

X= .500 ASYMMETRY DELTA= .175 FRACTIONAL= .7429

SPHERES -.06209 TANGENT .14442 LENGTH 9.772 ENERGY 457.52 SPACING .005 SADDLE .10349

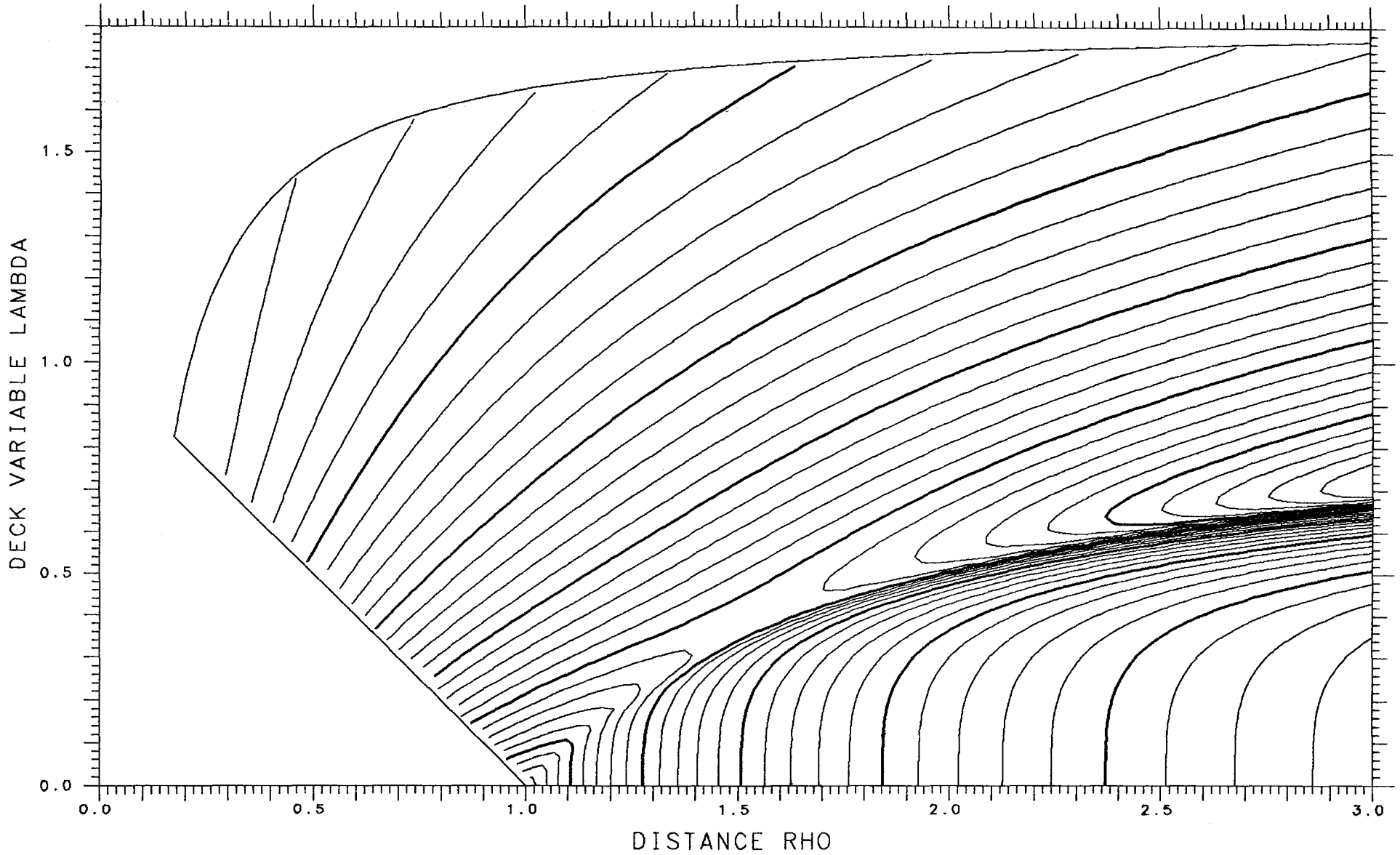

X= .925 ASYMMETRY DELTA= .050 FRACTIONAL= .5745
SPHERES -.41339 TANGENT .06261 LENGTH **12.855** ENERGY 709.11 SPACING .002

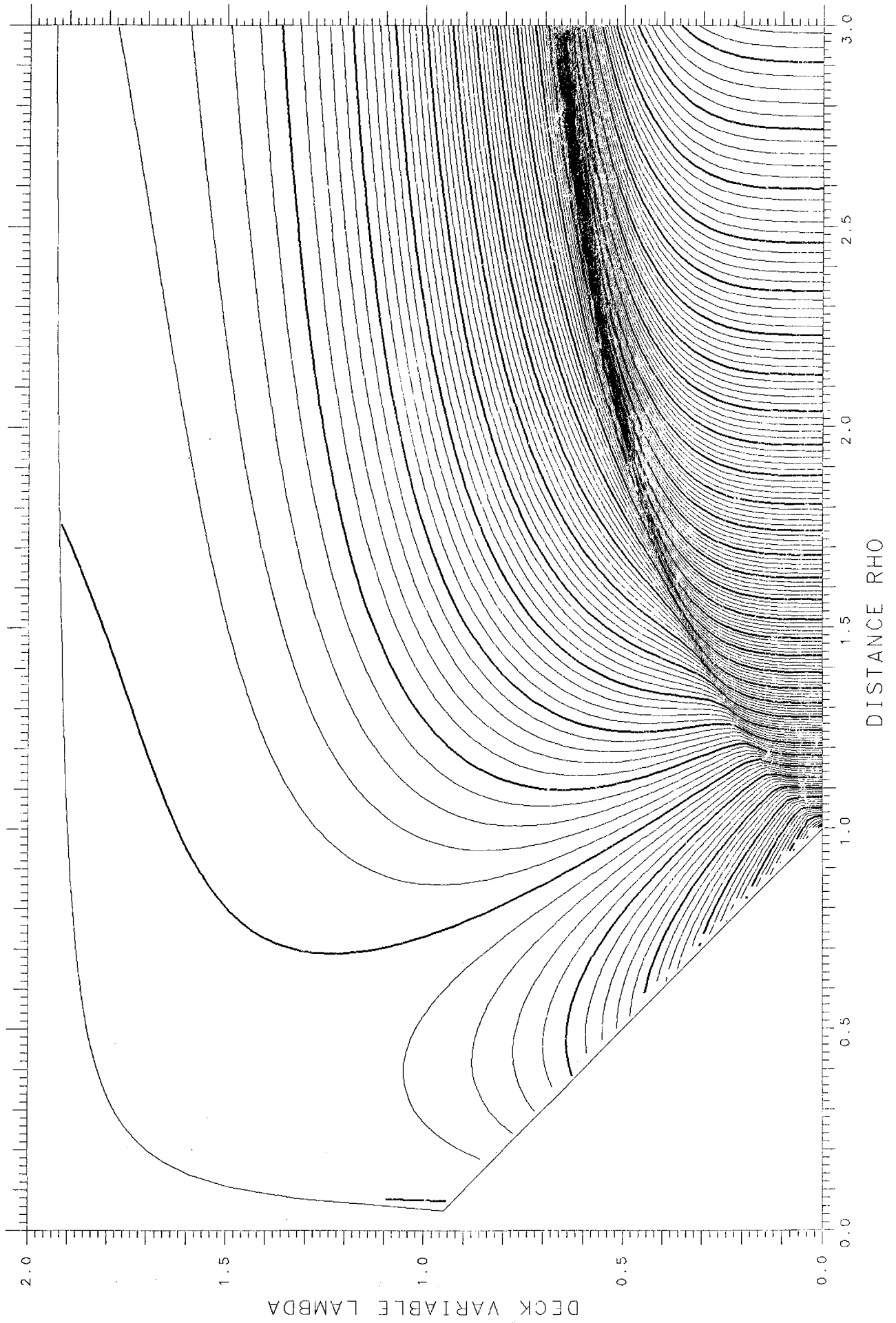

X= .500 ASYMMETRY DELTA= .200 FRACTIONAL= .7714

SPHERES -.05071 TANGENT .14155 LENGTH 9.689 ENERGY 457.52 SPACING .005 SADDLE .10437

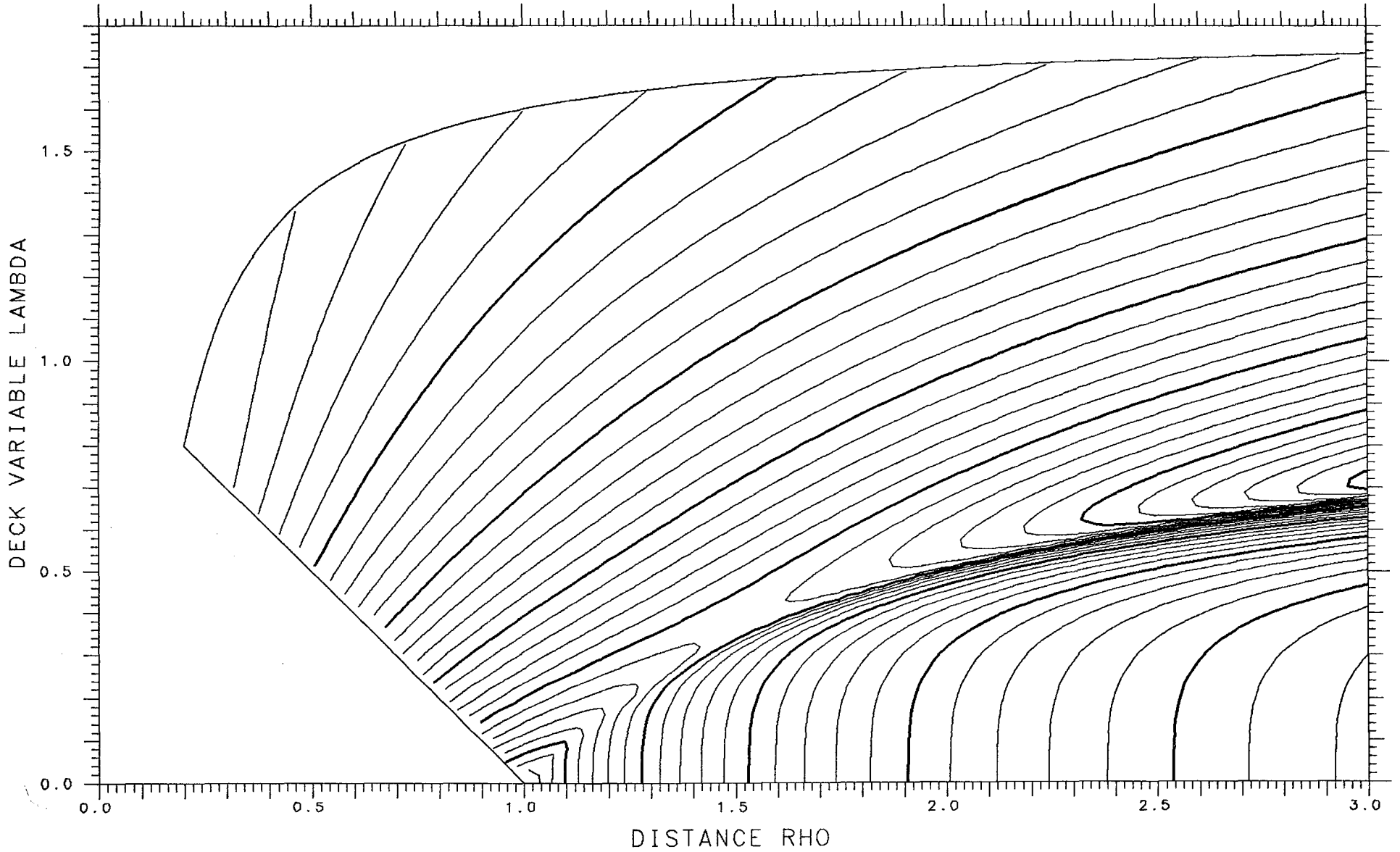

X= .925 ASYMMETRY DELTA= .025 FRACTIONAL= .5374

SPHERES -.42181 TANGENT .06137 LENGTH 12.879 ENERGY 709.11 SPACING .002

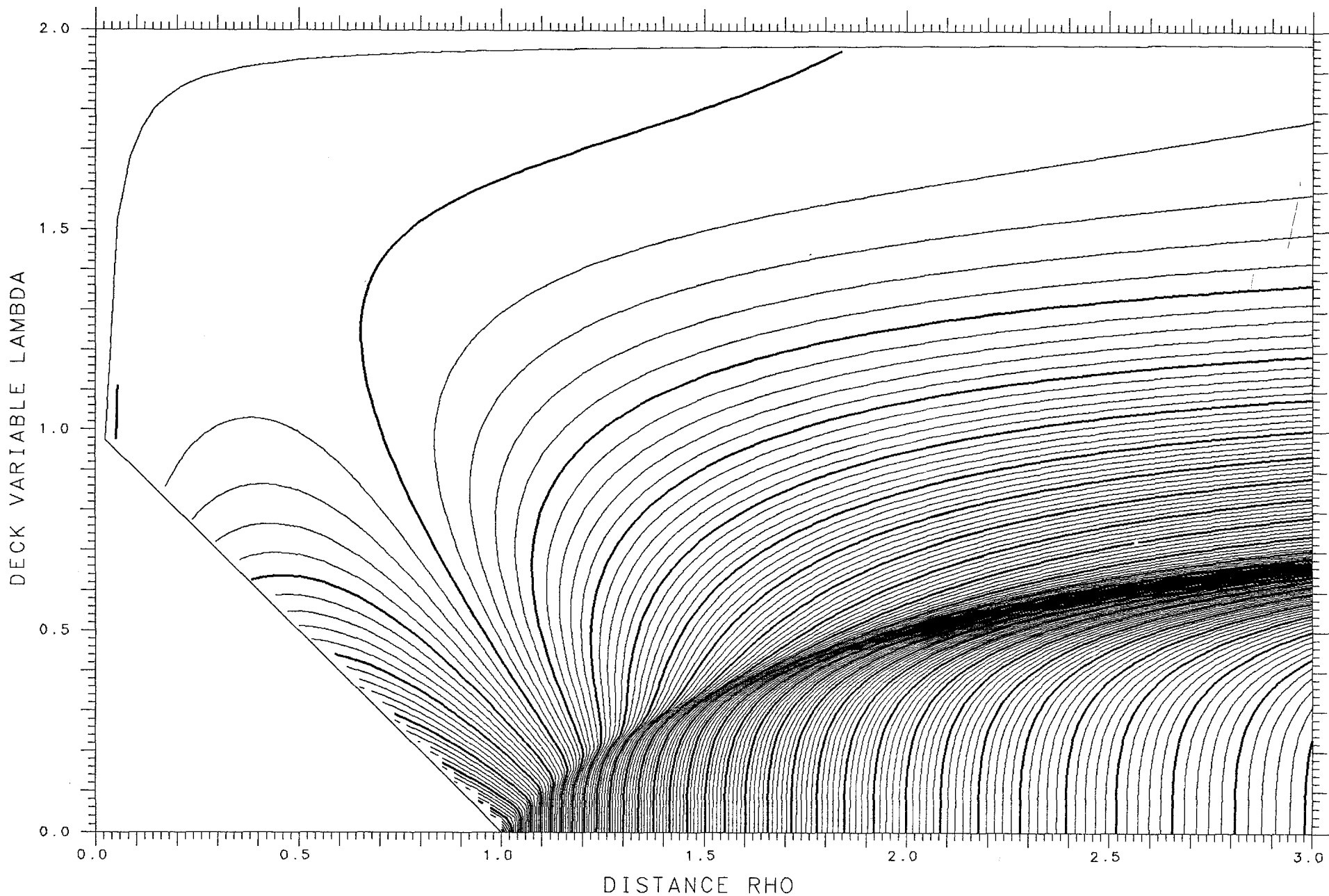

X= .500 ASYMMETRY DELTA= .225 FRACTIONAL= .7979

SPHERES -.03932 TANGENT .13812 LENGTH 9.599 ENERGY 457.52 SPACING .005 SADDLE .10482

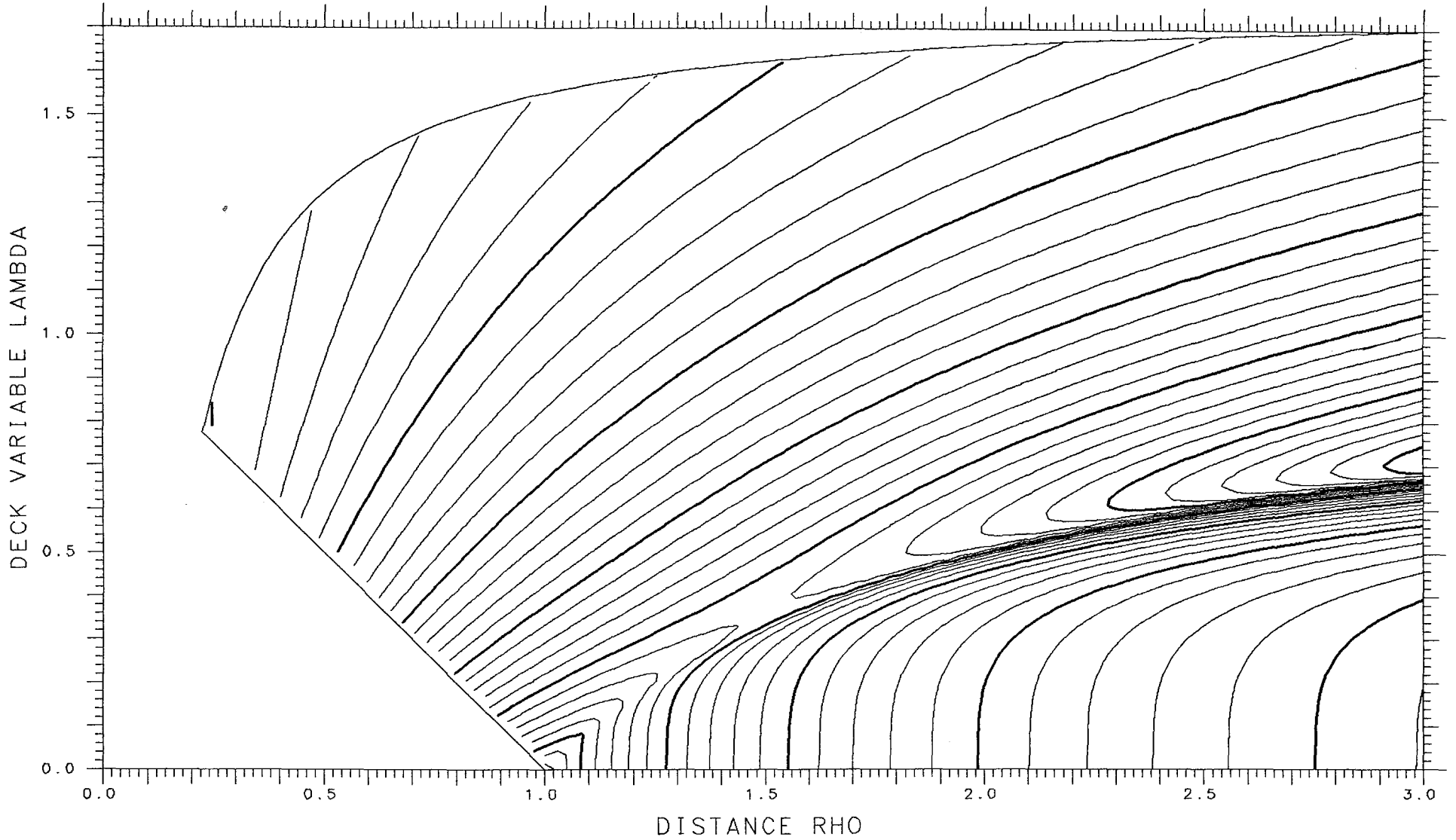

X= .925

ASYMMETRY DELTA=0.

FRACTIONAL= .5000

SPHERES -.42465

TANGENT .06094

LENGTH 12.887

ENERGY 709.11

SPACING .002

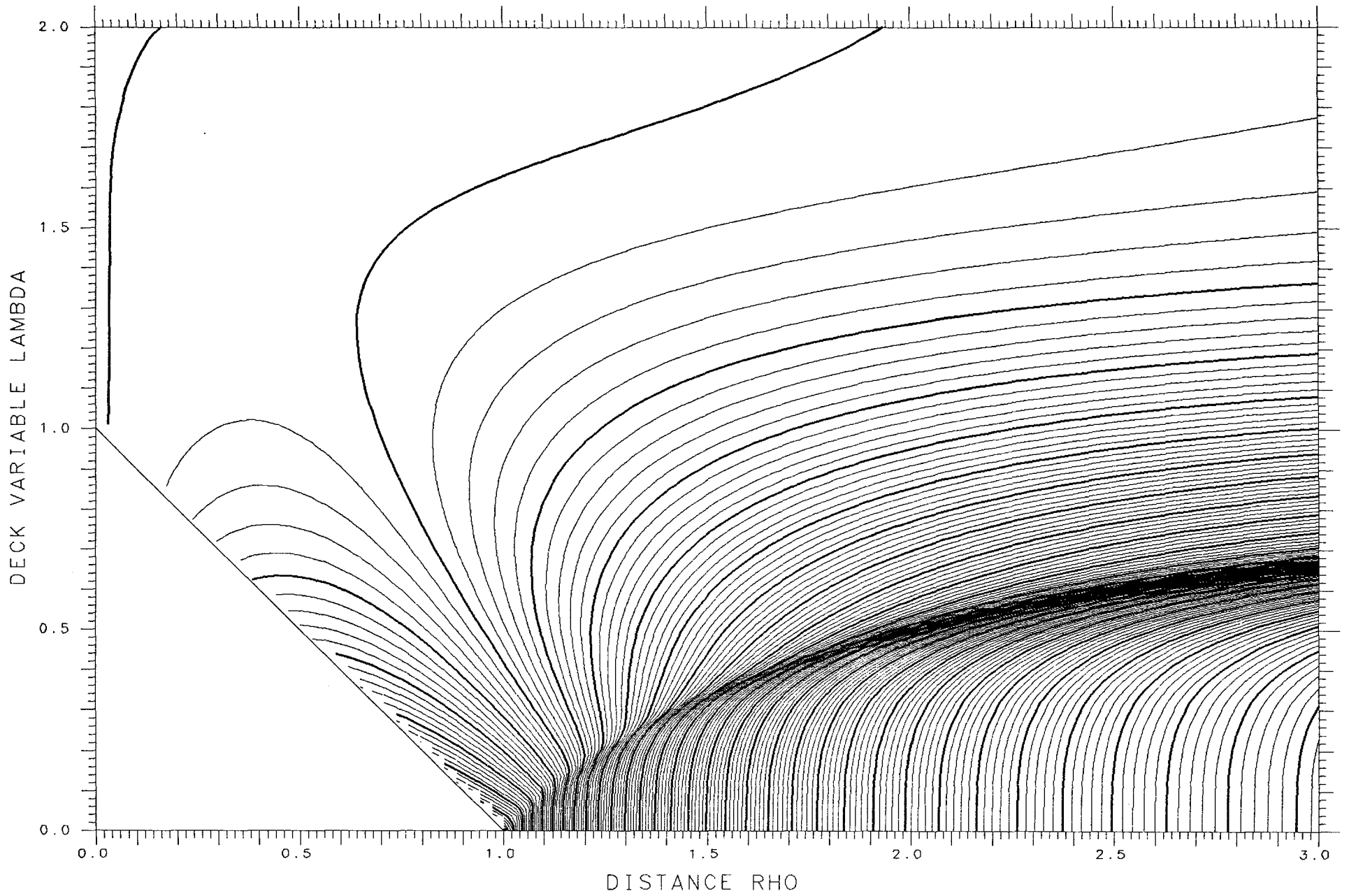

X= .500 ASYMMETRY DELTA= .250 FRACTIONAL= .8224

SPHERES -.02827 TANGENT .13415 LENGTH 9.502 ENERGY 457.52 SPACING .005 SADDLE .10471

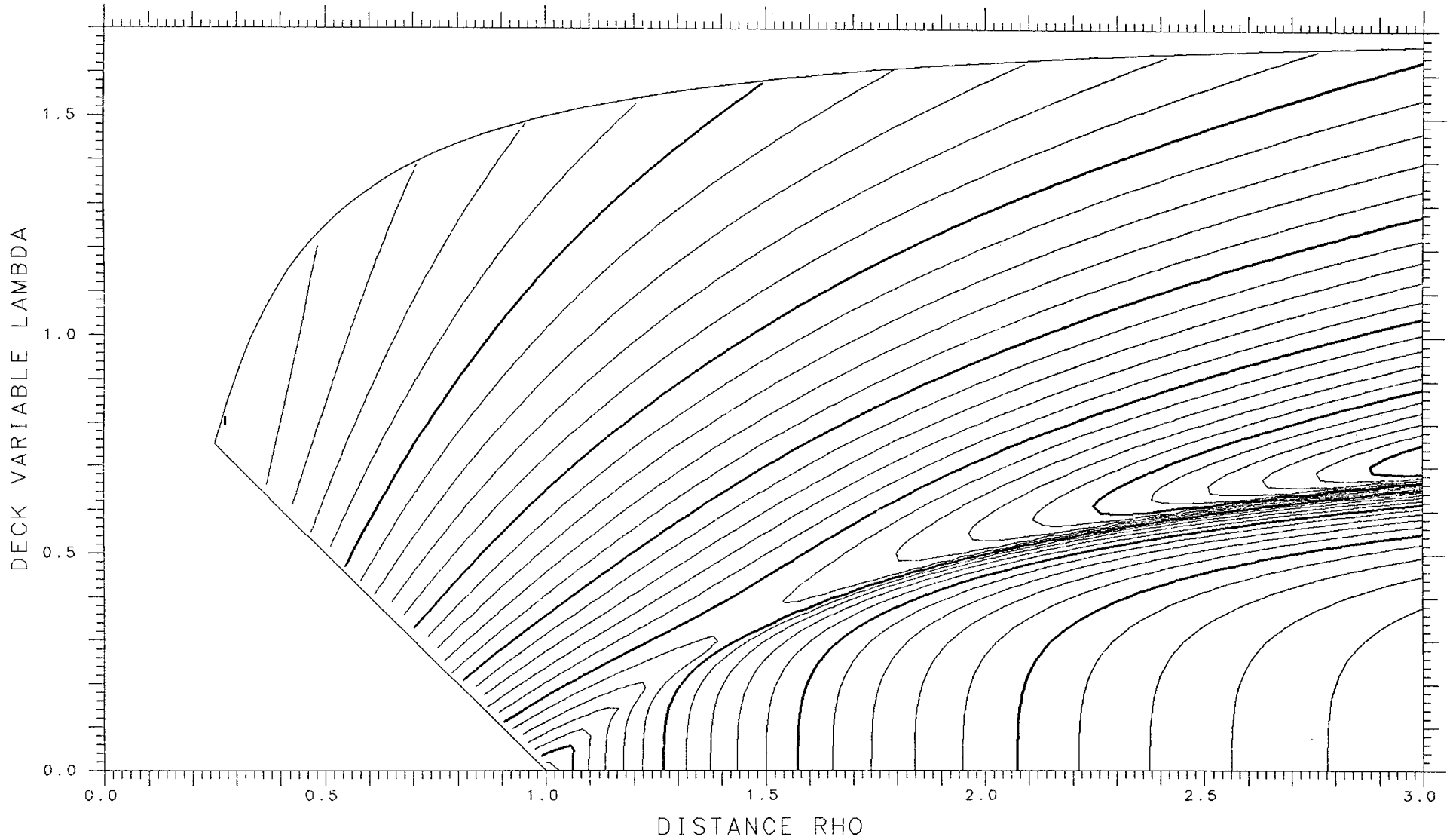

X= .900 ASYMMETRY DELTA= .600 FRACTIONAL= .9846

SPHERES .00737 TANGENT .04391 LENGTH 9.986 ENERGY 695.85 SPACING .002

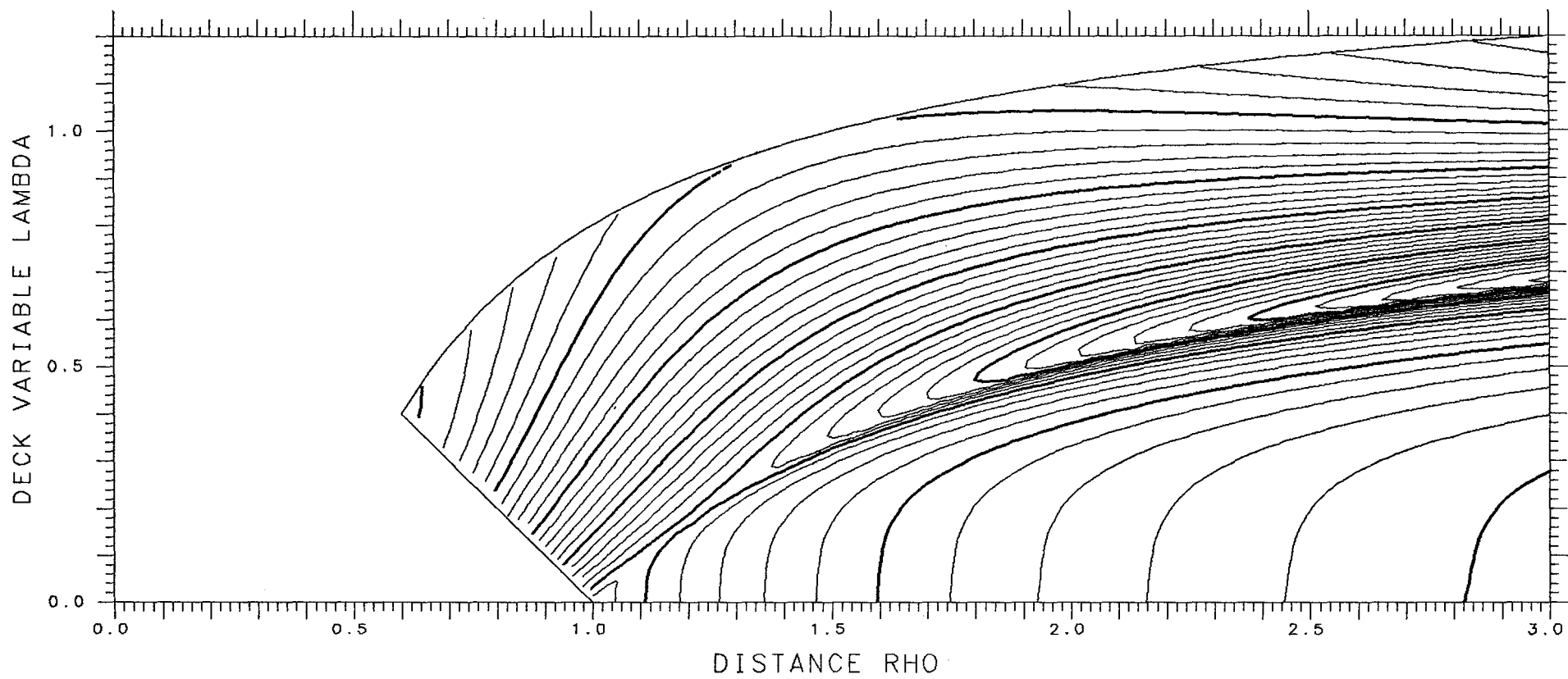

X= .500 ASYMMETRY DELTA= .275 FRACTIONAL= .8447

SPHERES -.01782 TANGENT .12963 LENGTH 9.399 ENERGY 457.52 SPACING .005 SADDLE .10396

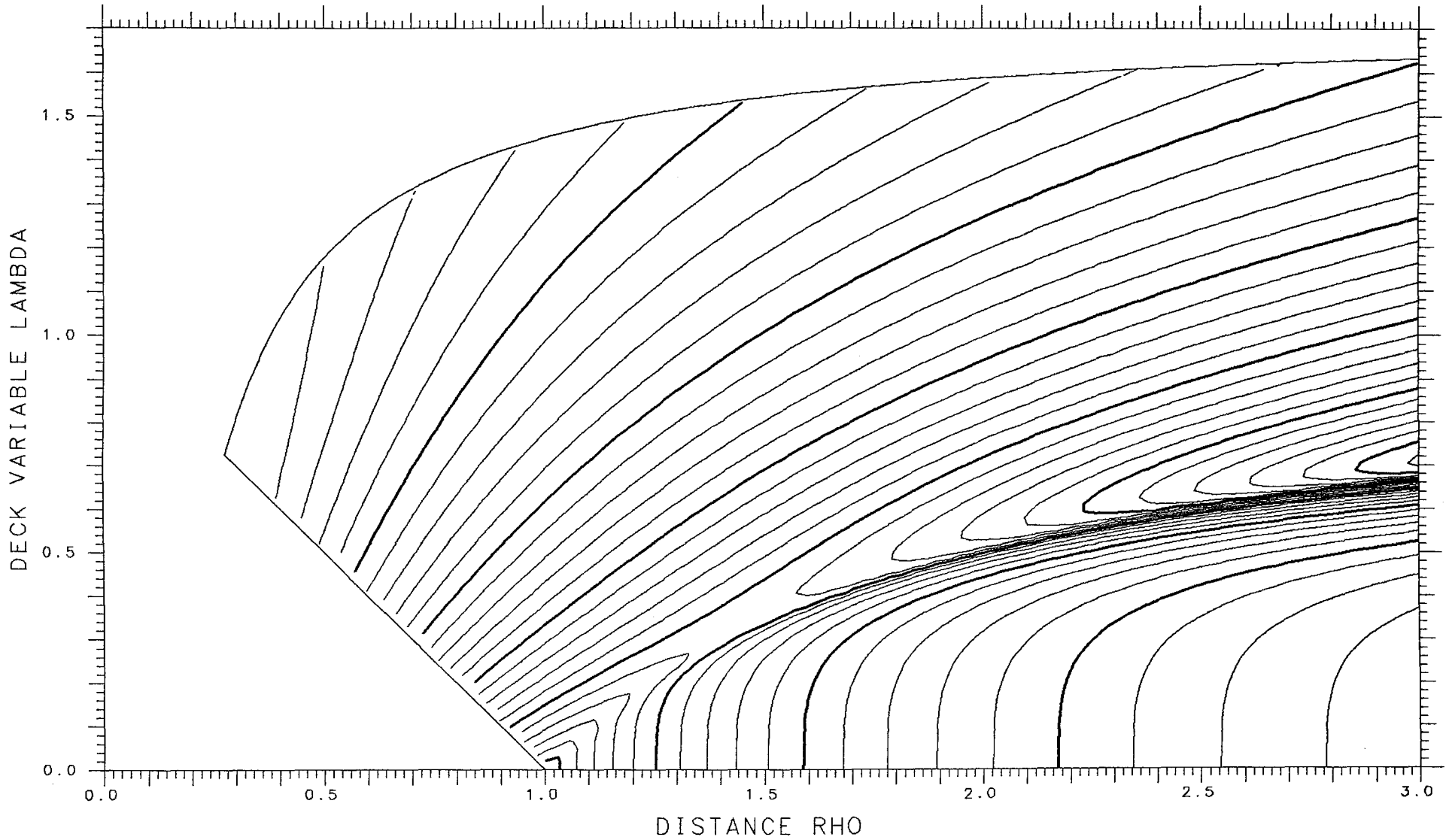

X= .900 ASYMMETRY DELTA= .575 FRACTIONAL= .9807

SPHERES .00404 TANGENT .04898 LENGTH 10.131 ENERGY 695.85 SPACING .002

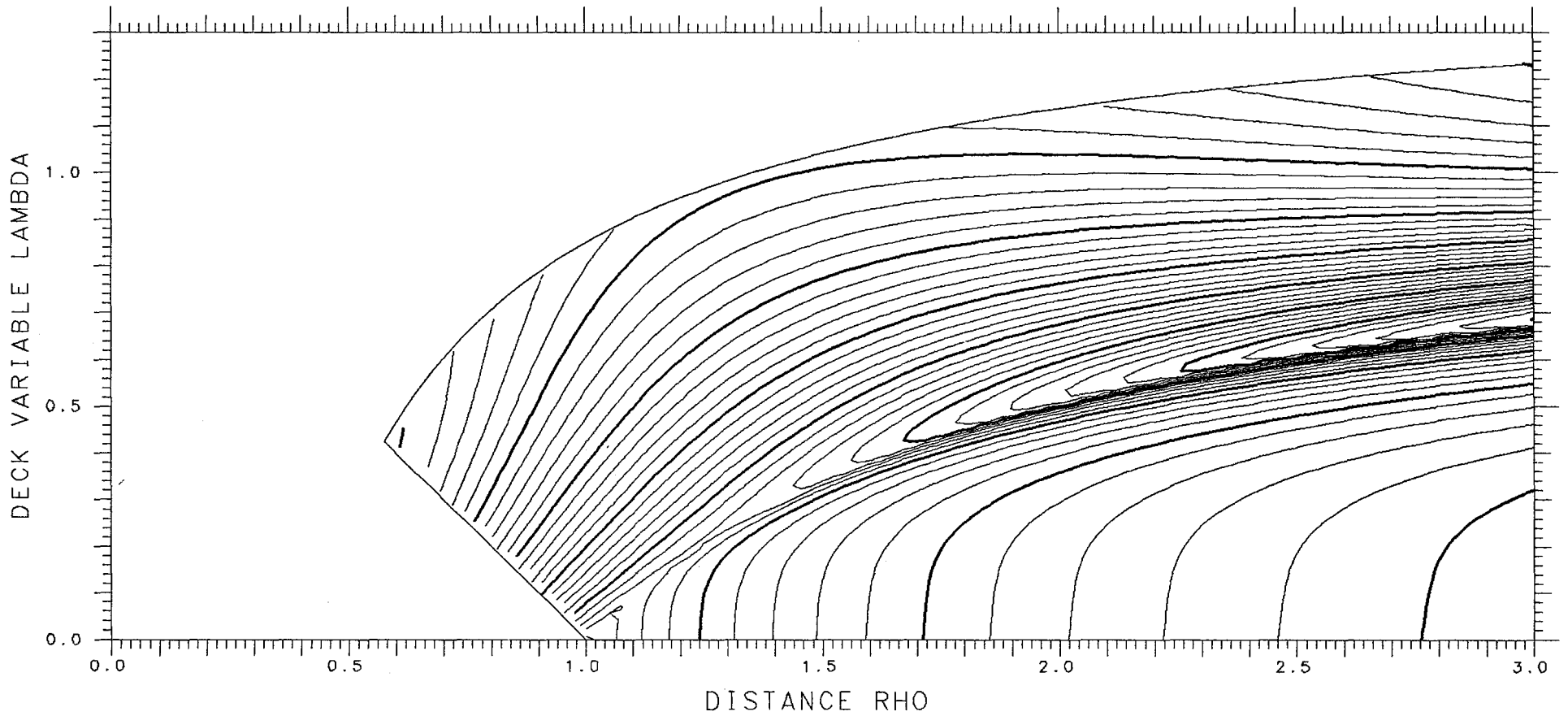

X= .500 ASYMMETRY DELTA= .300 FRACTIONAL= .8650

SPHERES -.00820 TANGENT .12460 LENGTH 9.292 ENERGY 457.52 SPACING .005 SADDLE .10251

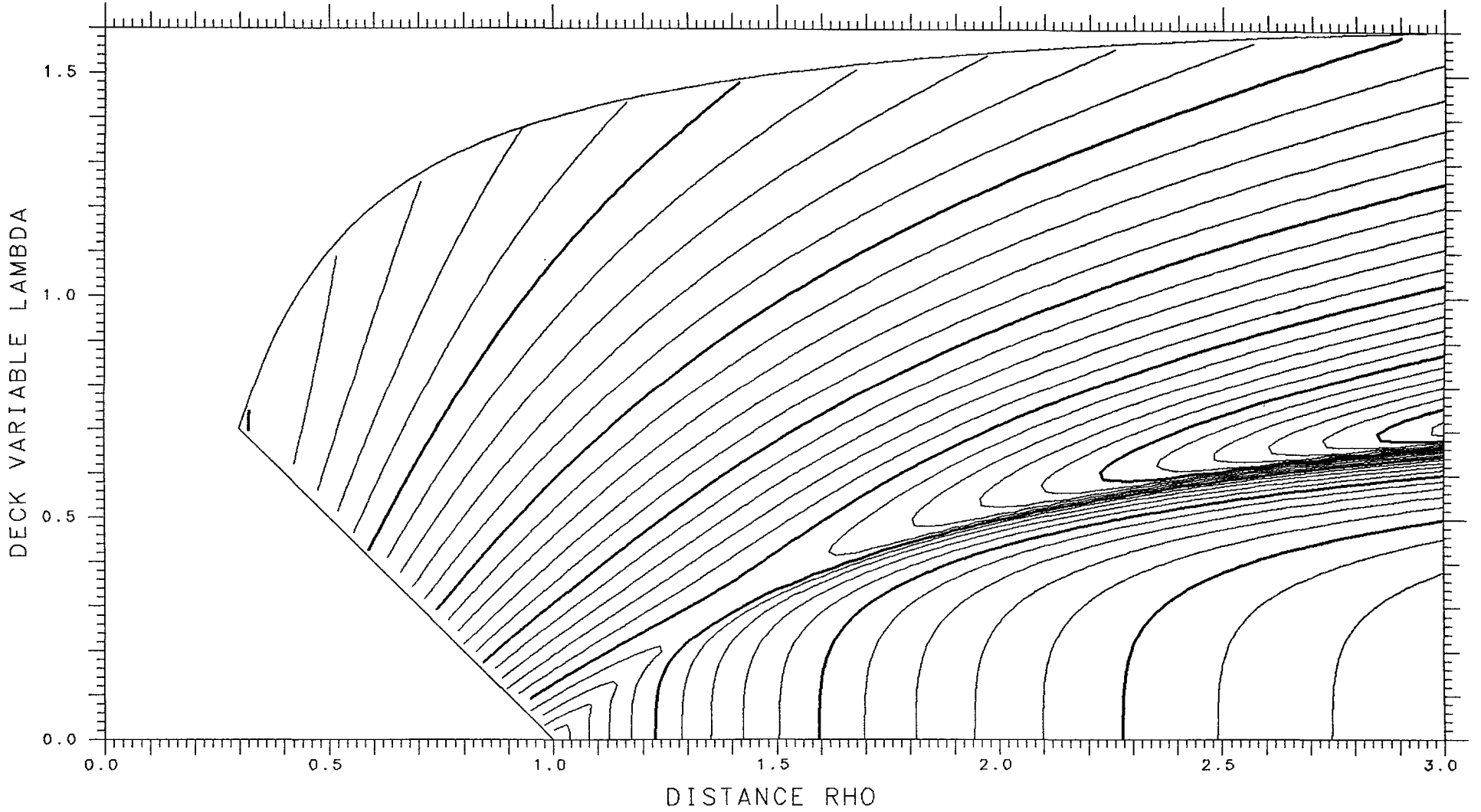

X= .900 ASYMMETRY DELTA= .550 FRACTIONAL= .9761

SPHERES -.00057 TANGENT .05408 LENGTH 10.278 ENERGY 695.85 SPACING .002

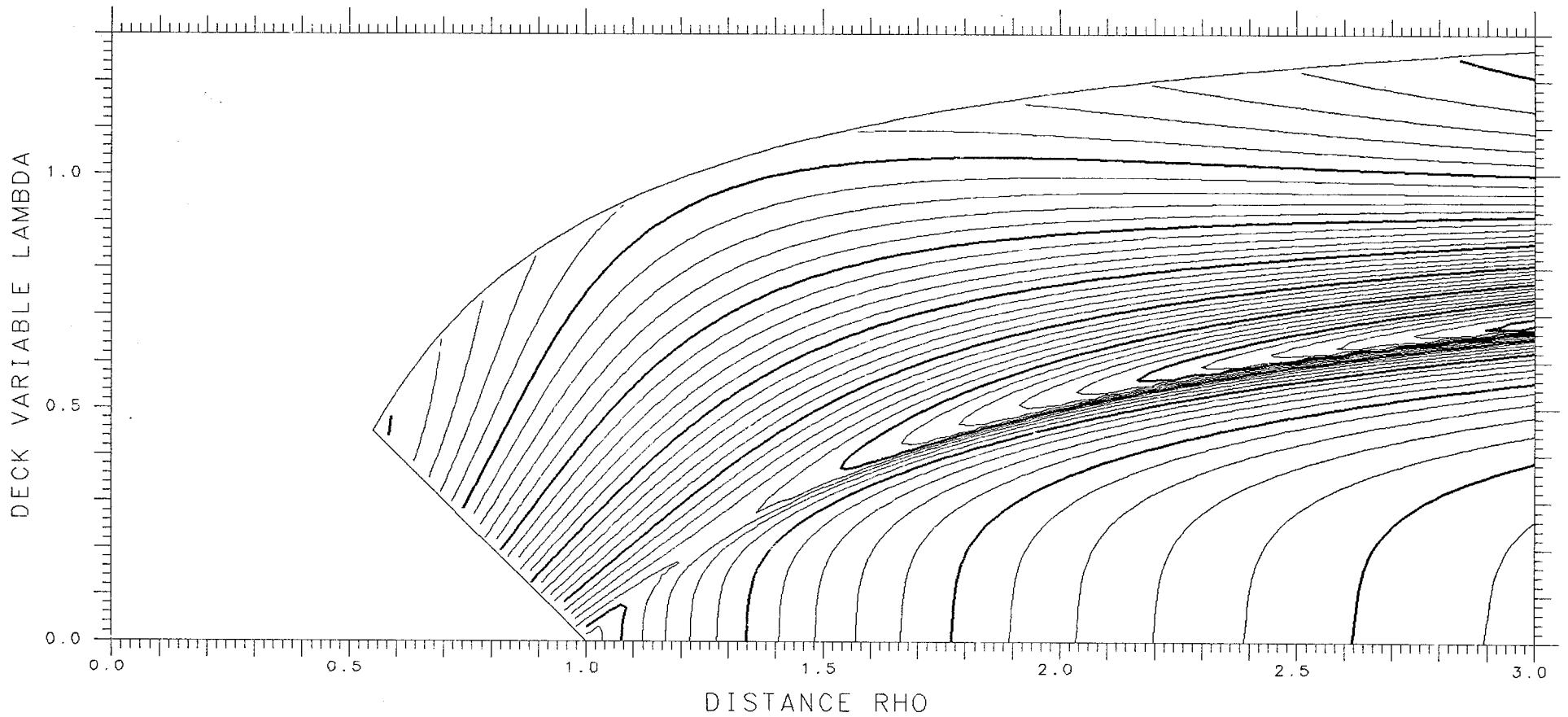

X= .500 ASYMMETRY DELTA= .325 FRACTIONAL= .8832

SPHERES .00041 TANGENT .11910 LENGTH 9.180 ENERGY 457.52 SPACING .005 SADDLE .10035

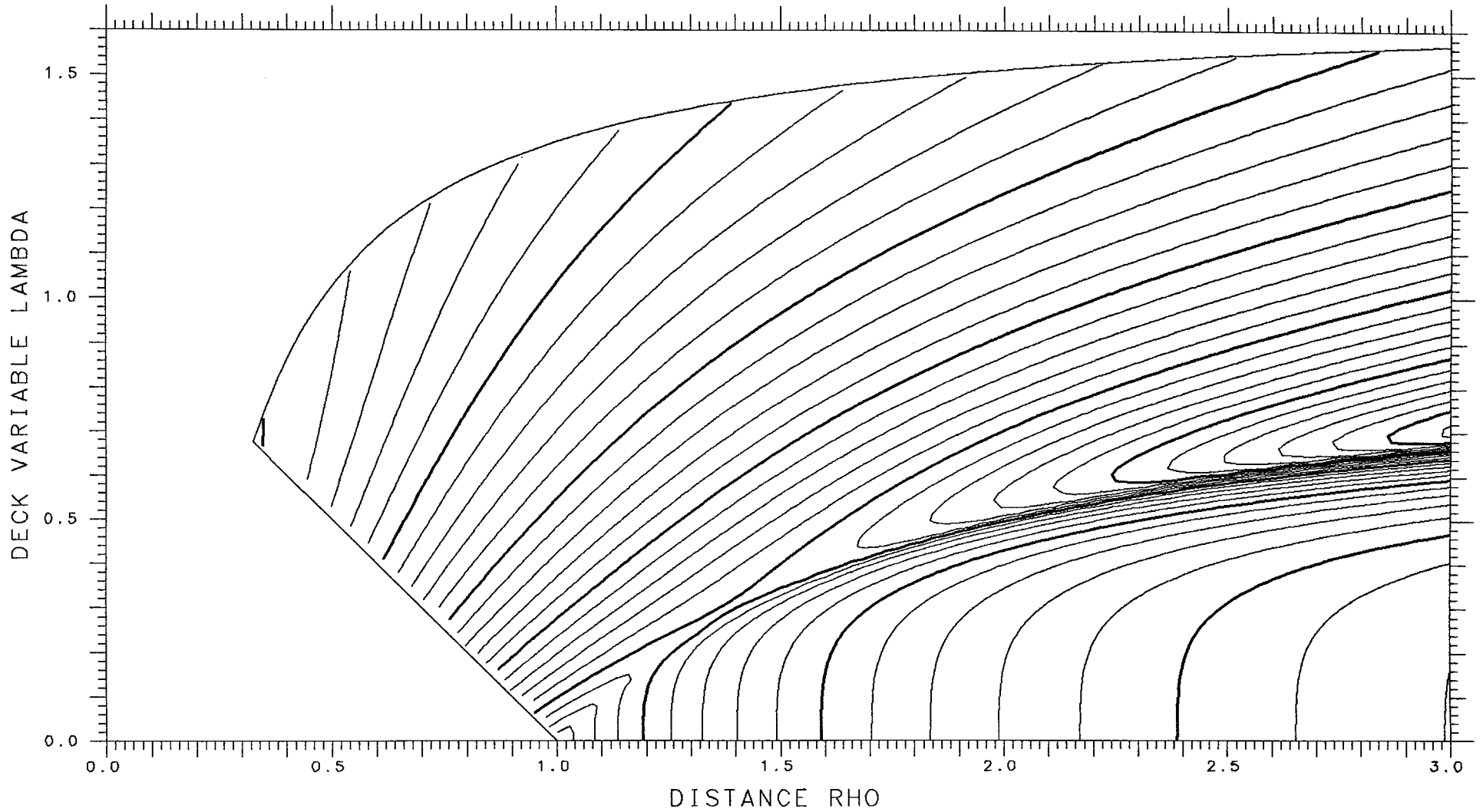

X= .900 ASYMMETRY DELTA= .525 FRACTIONAL= .9707

SPHERES -.00665 TANGENT .05913 LENGTH 10.427 ENERGY 695.85 SPACING .002

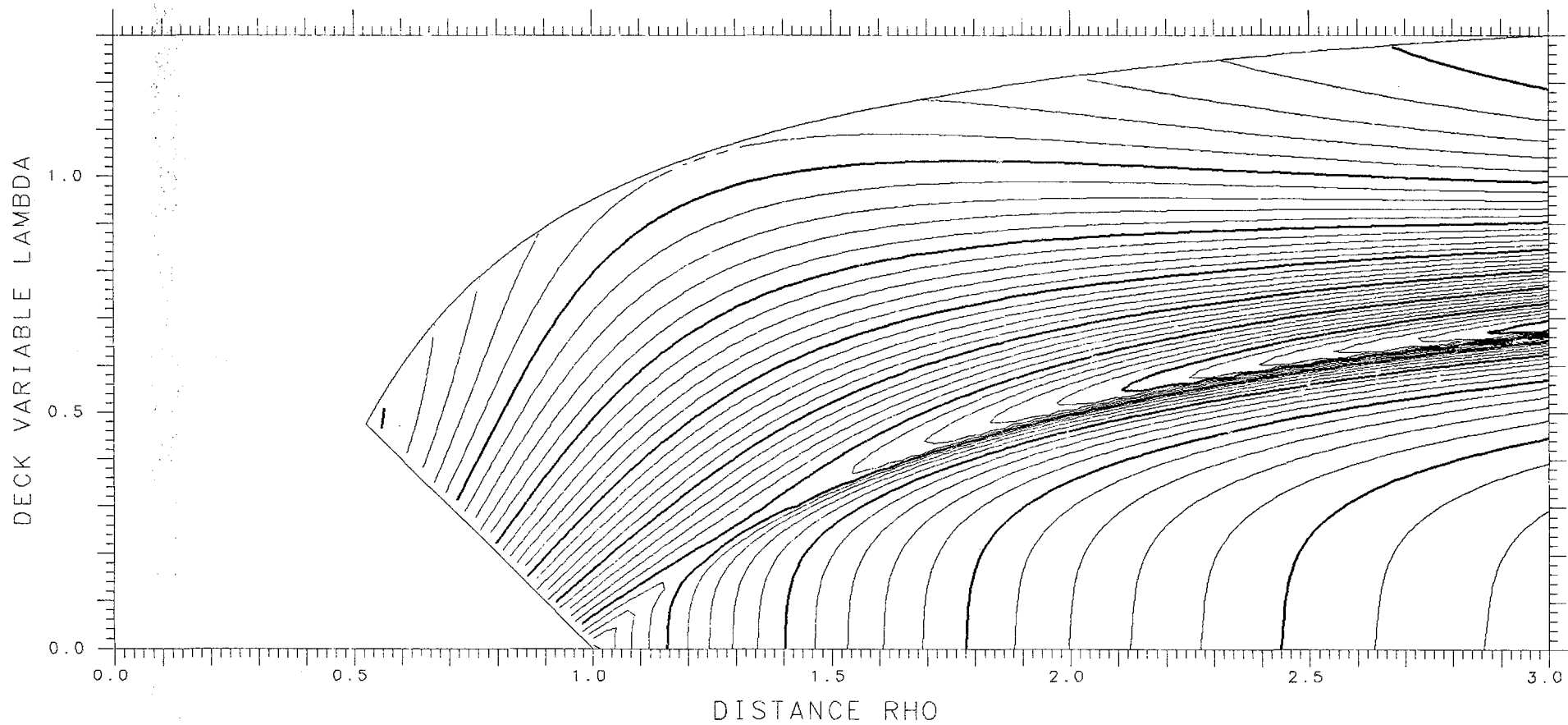

X= .500 ASYMMETRY DELTA= .350 FRACTIONAL= .8996

SPHERES .00793 TANGENT .11319 LENGTH 9.065 ENERGY 457.52 SPACING .005 SADDLE .09749

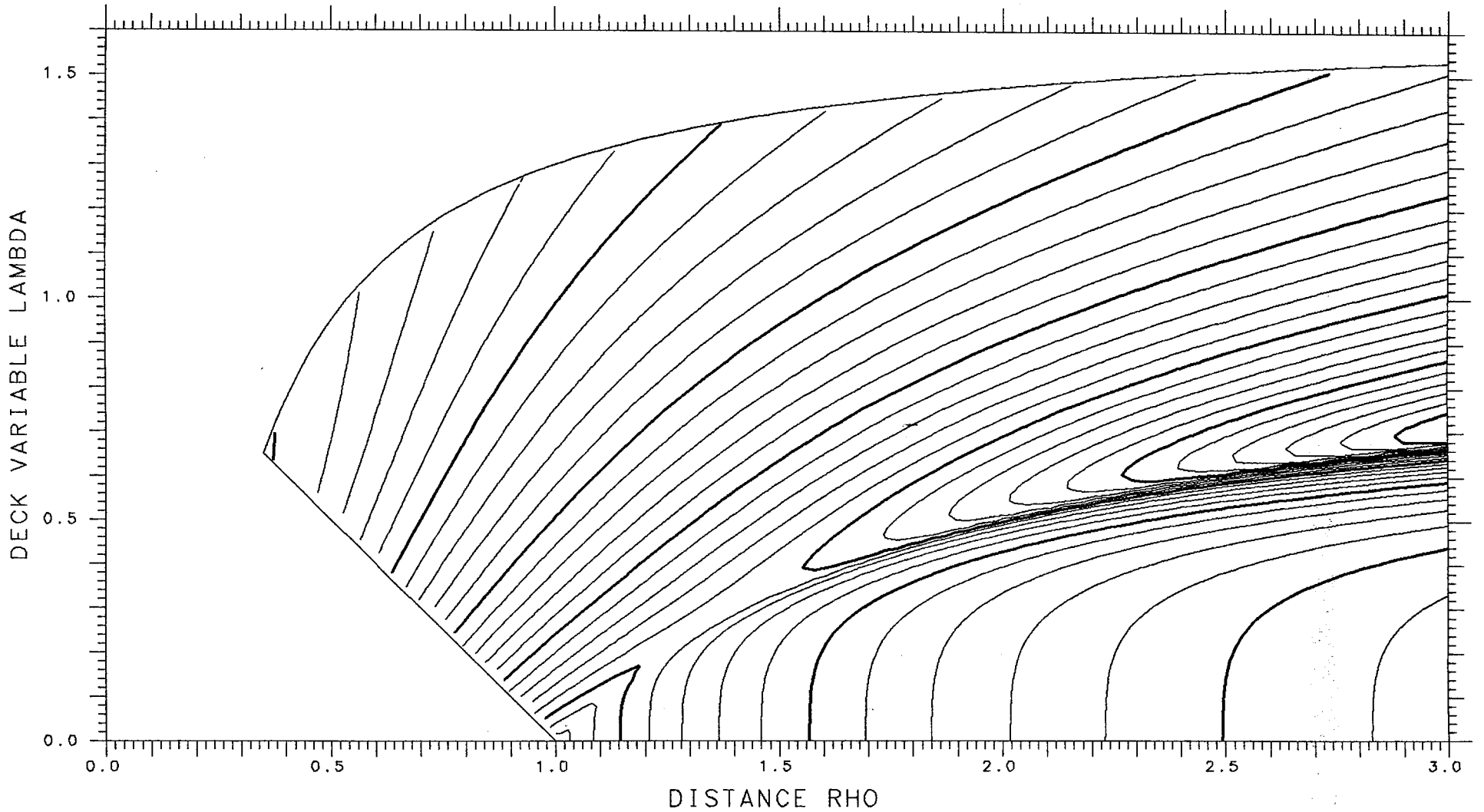

X= .900 ASYMMETRY DELTA= .500 FRACTIONAL= .9643

SPHERES -.01439 TANGENT .06404 LENGTH 10.578 ENERGY 695.85 SPACING .002

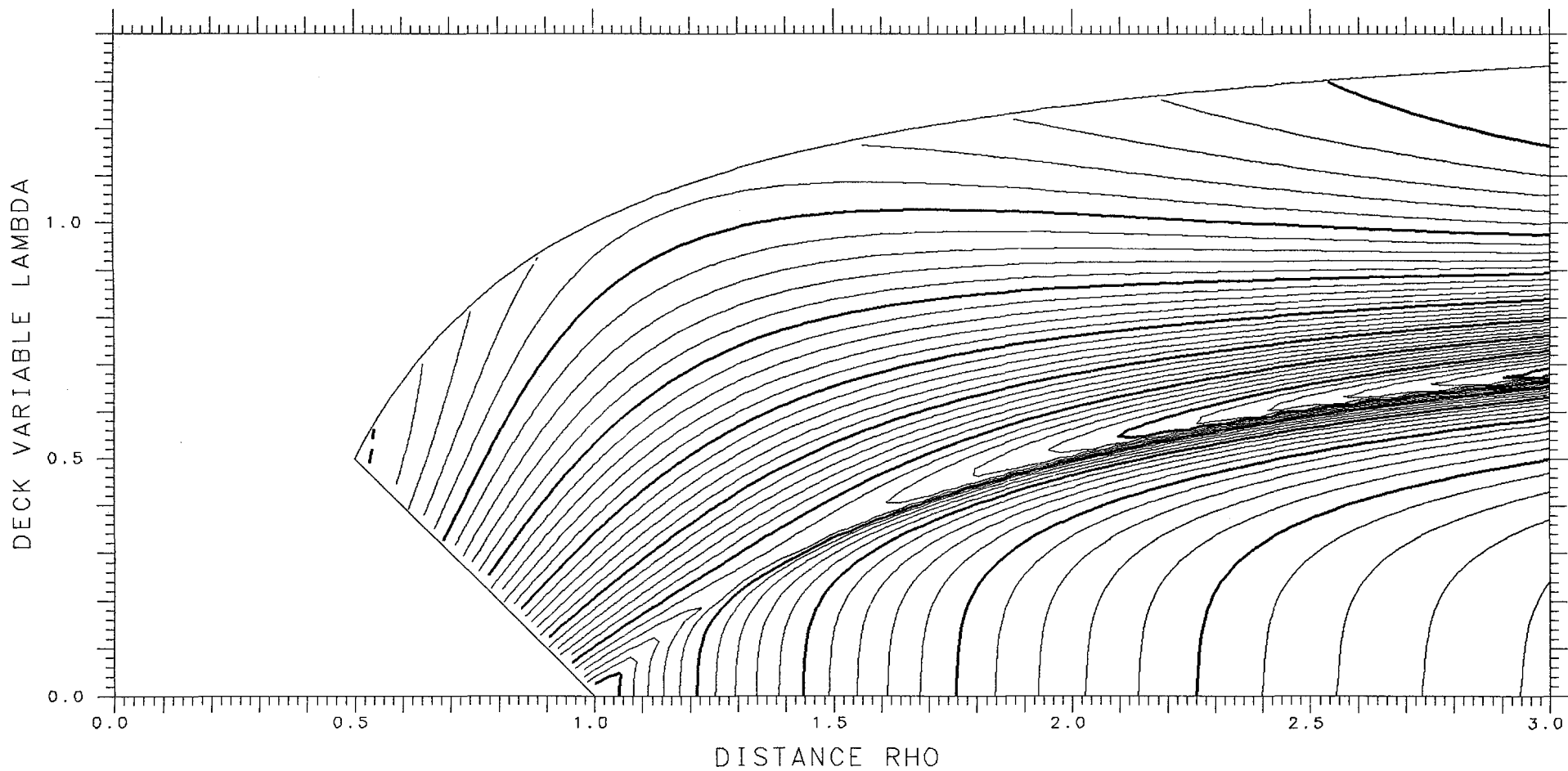

X= .500 ASYMMETRY DELTA= .375 FRACTIONAL= .9141

SPHERES .01428 TANGENT .10694 LENGTH 8.948 ENERGY 457.52 SPACING .005

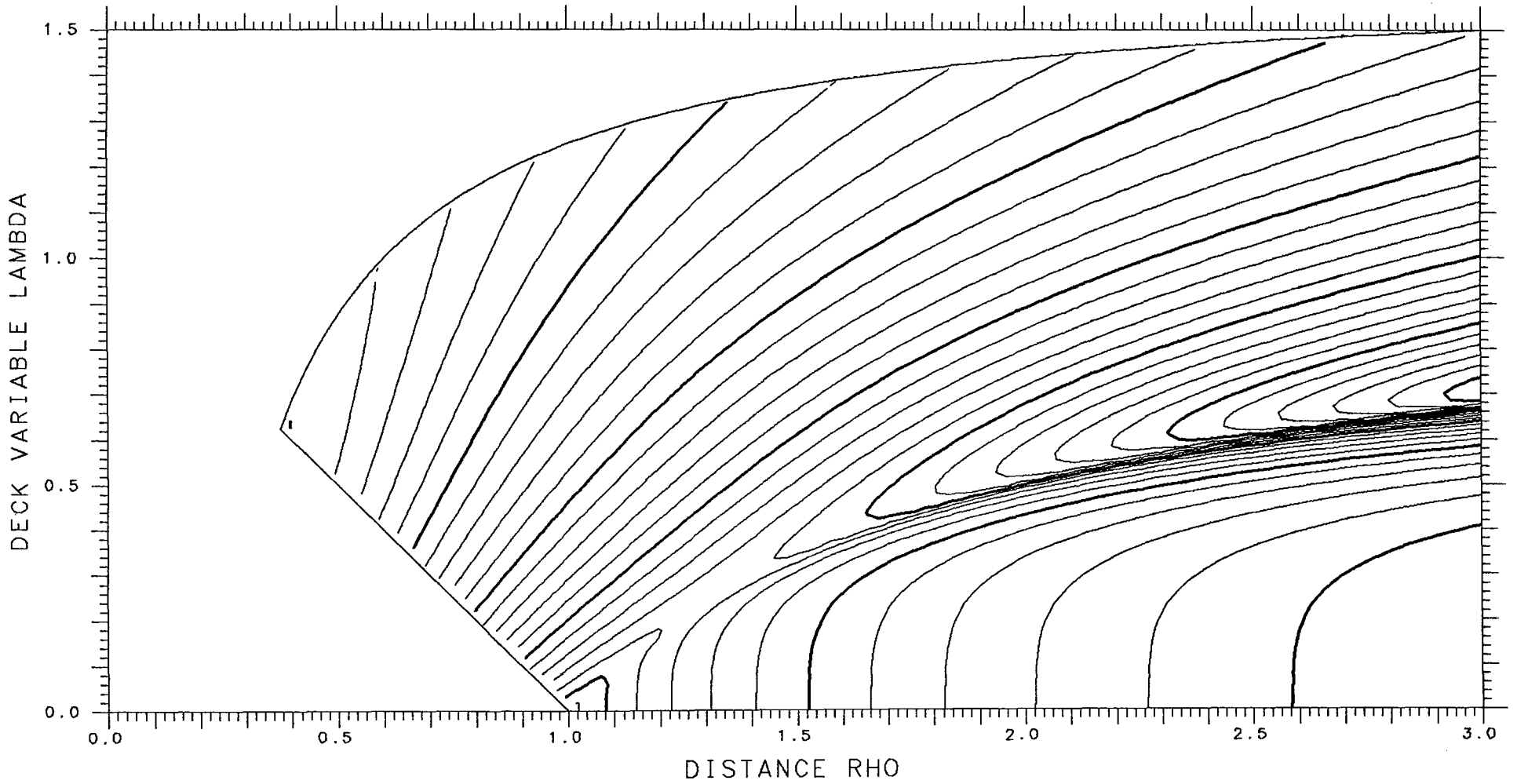

X= .900 ASYMMETRY DELTA= .475 FRACTIONAL= .9569

SPHERES -.02397 TANGENT .06872 LENGTH 10.729 ENERGY 695.85 SPACING .002 SADDLE .05384

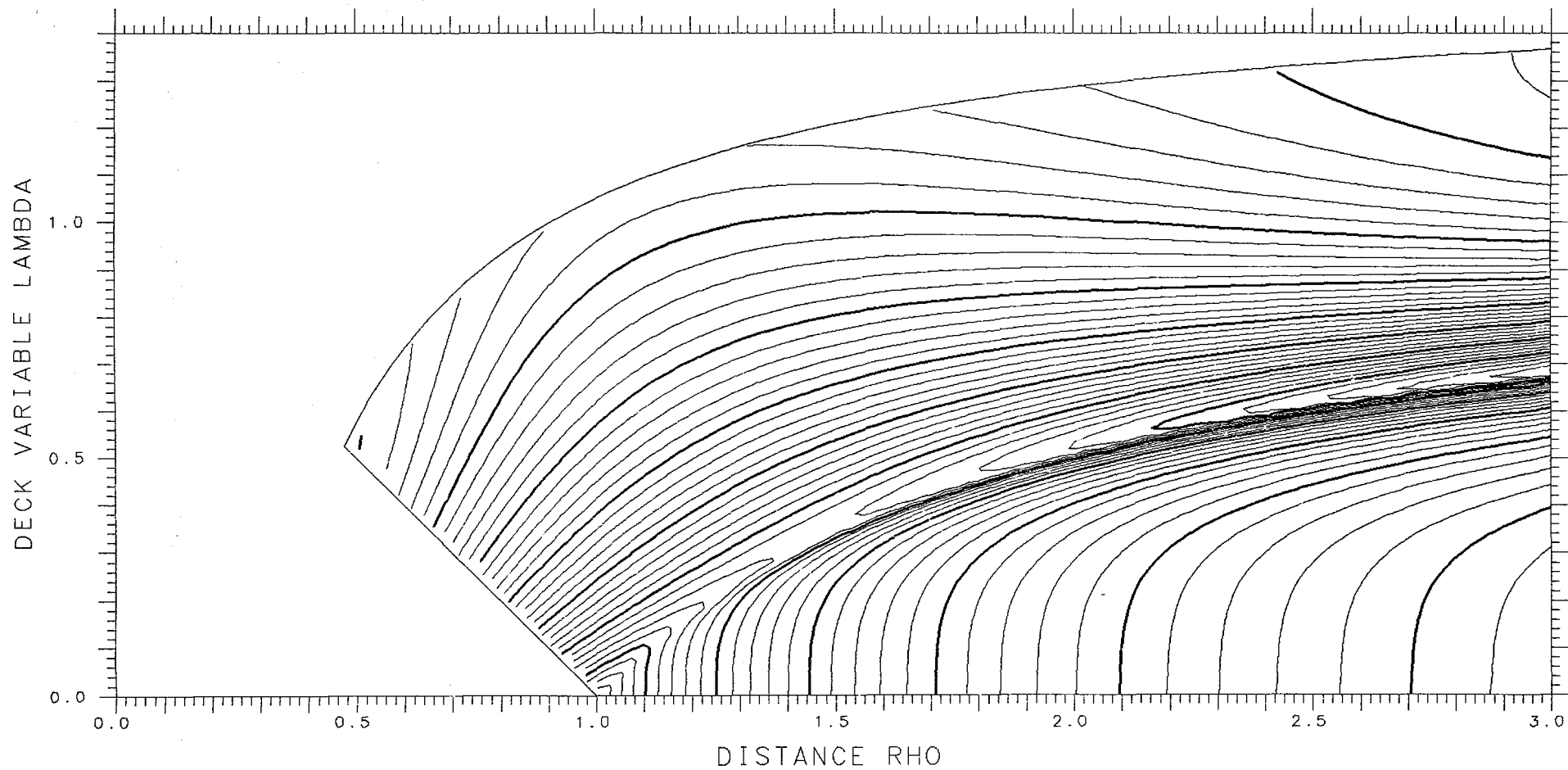

X= .500 ASYMMETRY DELTA= .400 FRACTIONAL= .9270

SPHERES .01947 TANGENT .10041 LENGTH 8.830 ENERGY 457.52 SPACING .005

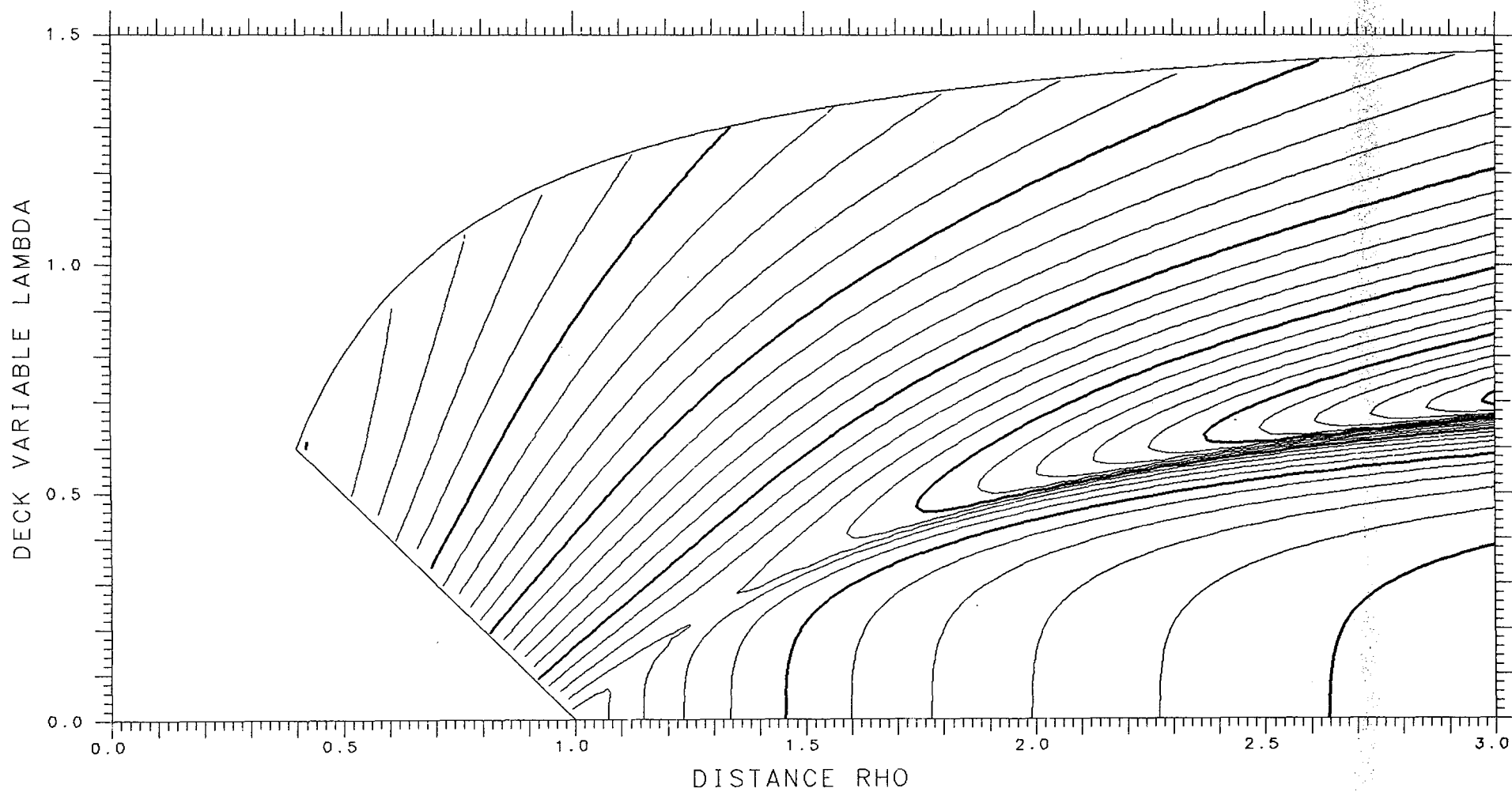

X= .900 ASYMMETRY DELTA= .450 FRACTIONAL= .9483

SPHERES -.03556 TANGENT .07308 LENGTH 10.881 ENERGY 695.85 SPACING .002 SADDLE .05391

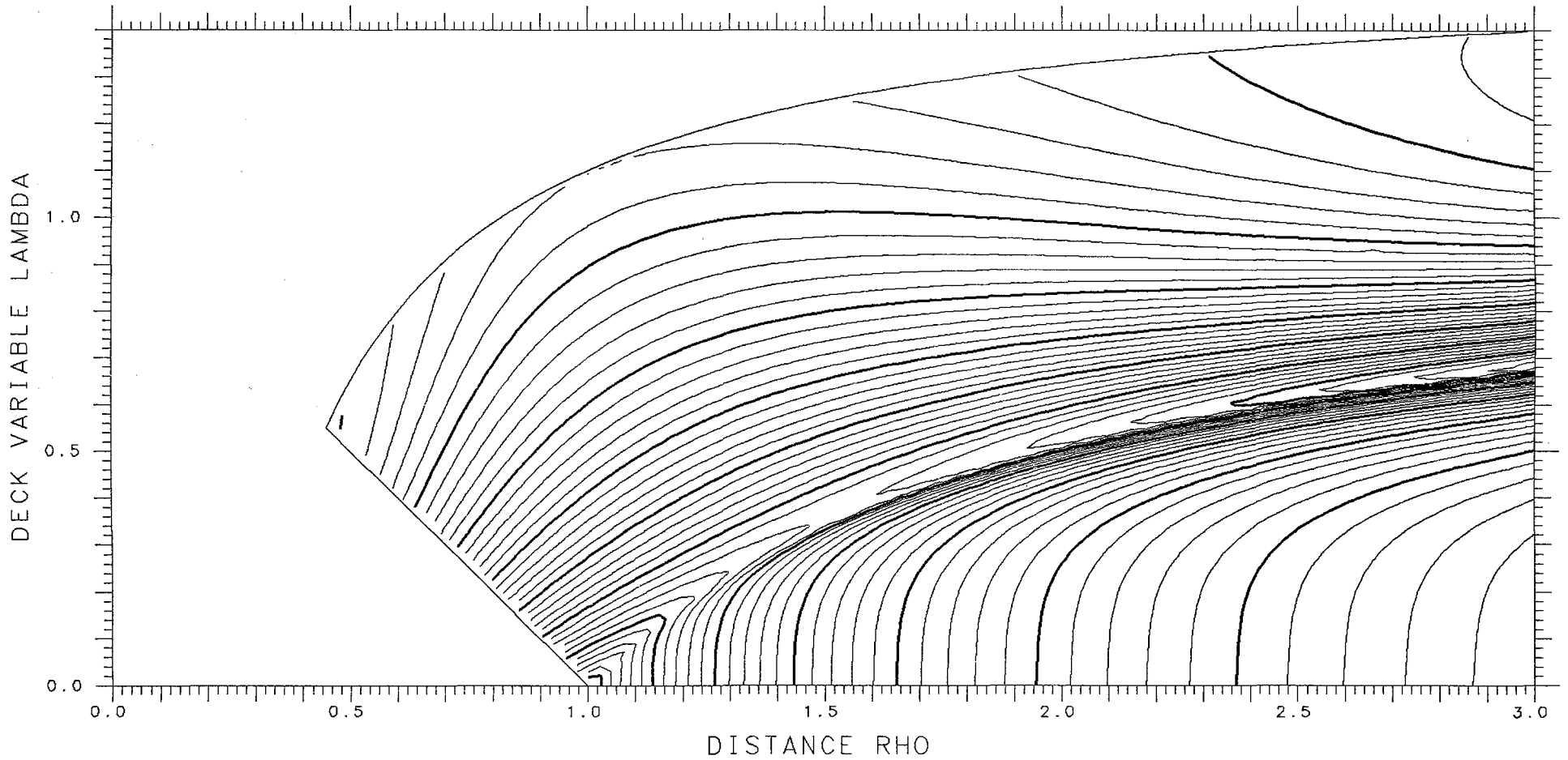

X= .500 ASYMMETRY DELTA= .425 FRACTIONAL= .9384

SPHERES .02352 TANGENT .09369 LENGTH 8.710 ENERGY 457.52 SPACING .005

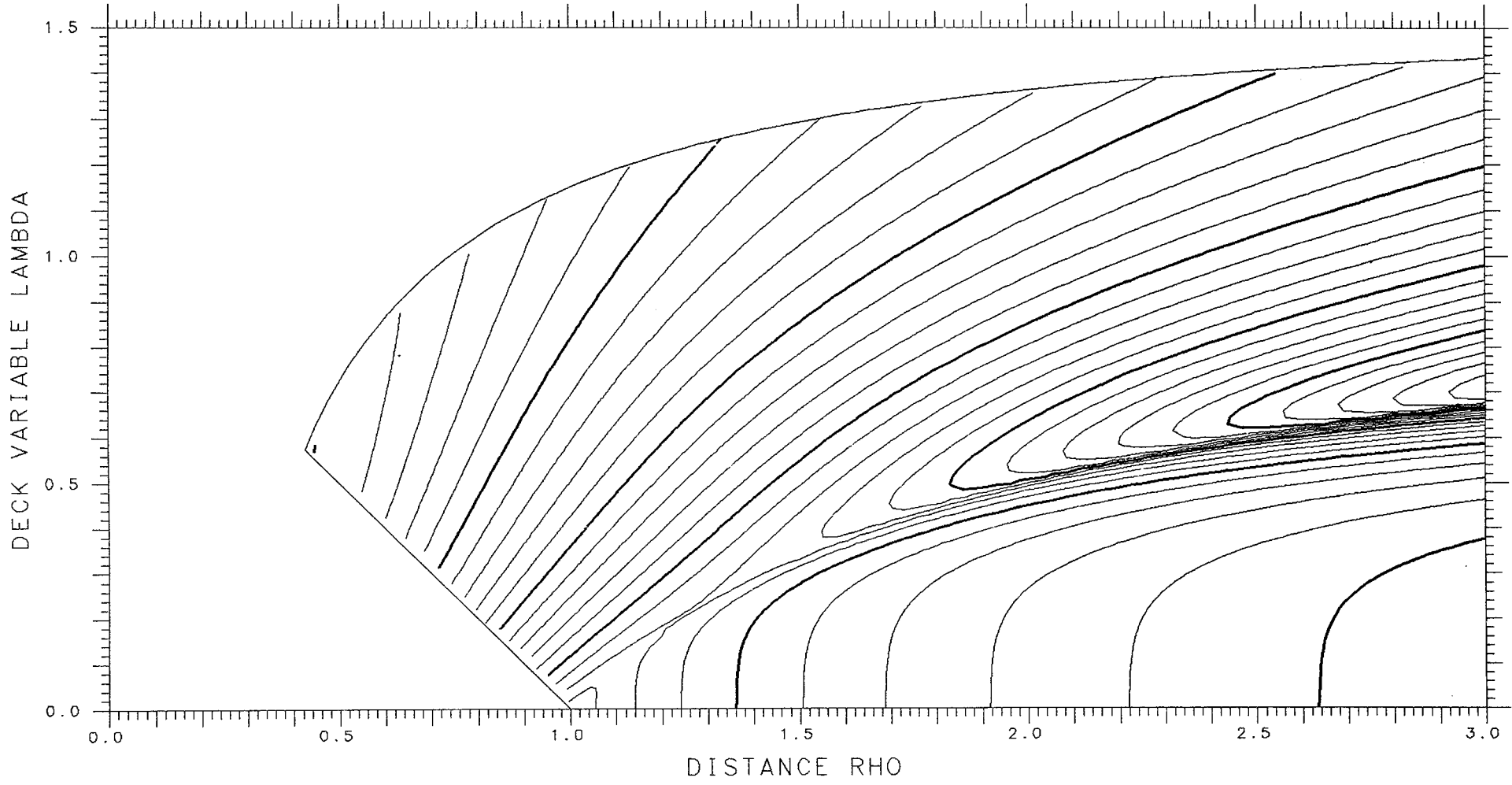

X= .900 ASYMMETRY DELTA= .425 FRACTIONAL= .9384

SPHERES -.04928 TANGENT .07702 LENGTH 11.034 ENERGY 695.85 SPACING .002 SADDLE .05264

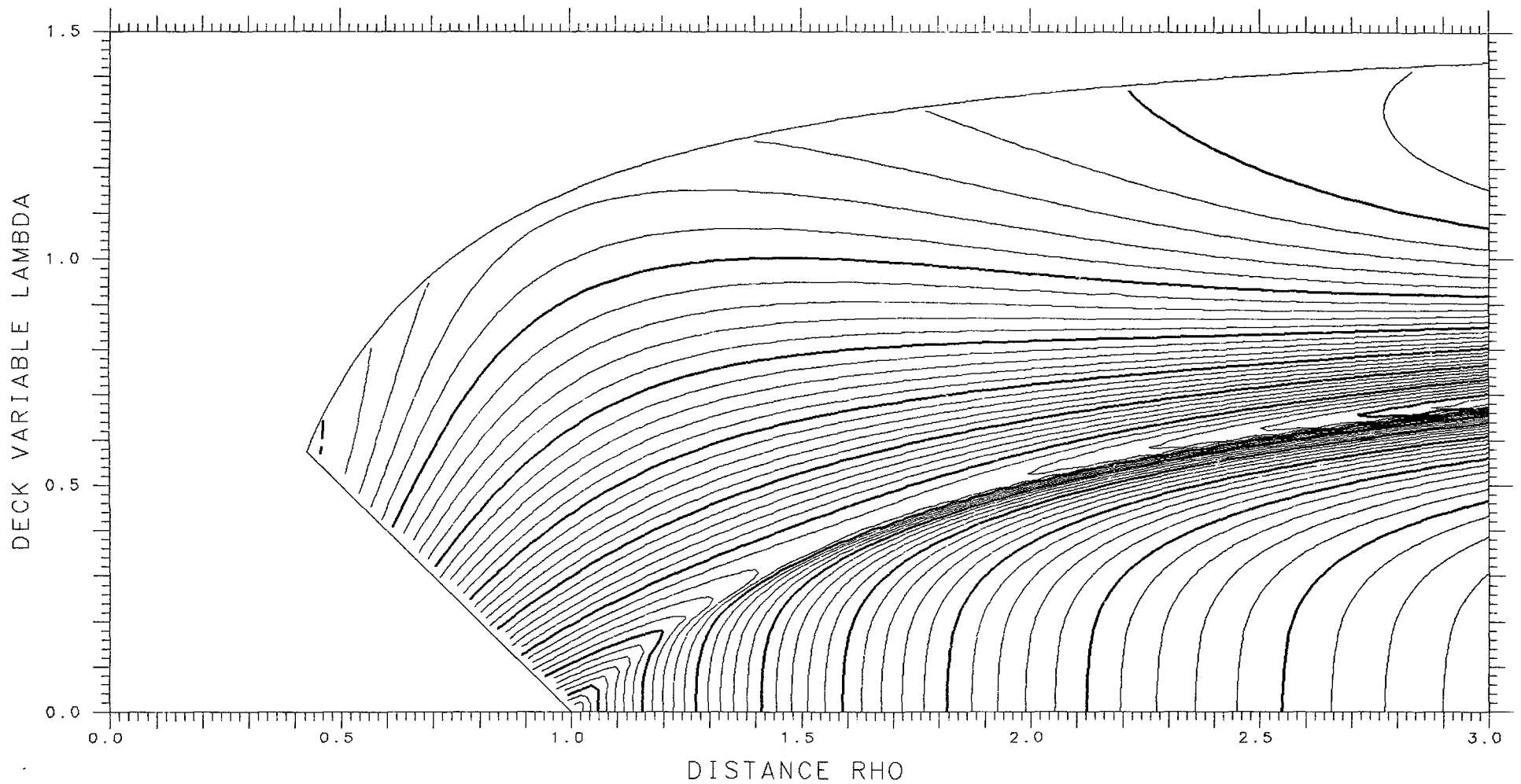

X= .500 ASYMMETRY DELTA= .450 FRACTIONAL= .9483

SPHERES .02650 TANGENT .08685 LENGTH 8.590 ENERGY 457.52 SPACING .005

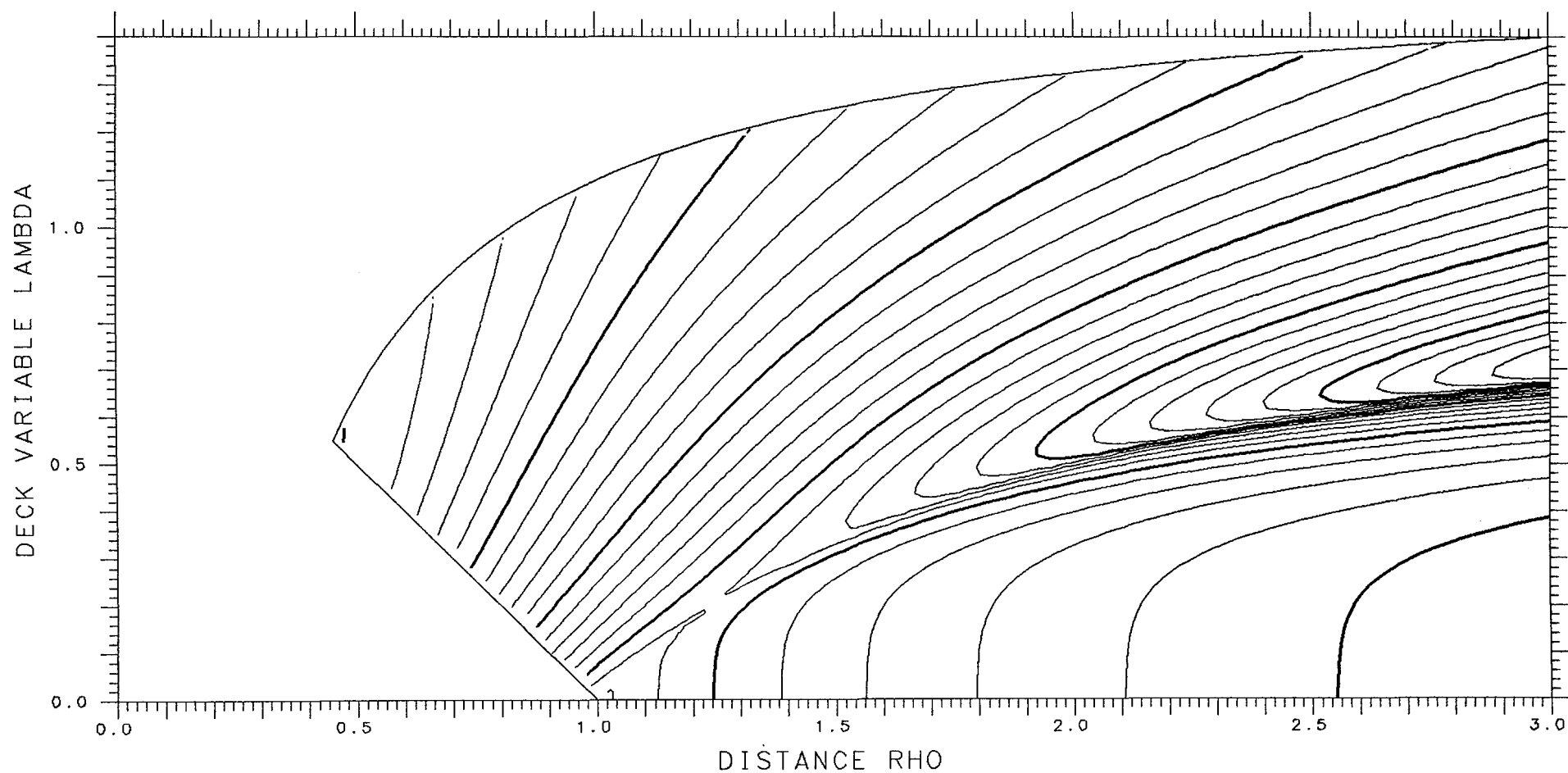

X= .900 ASYMMETRY DELTA= .400 FRACTIONAL= .9270

SPHERES -.06525 TANGENT .08045 LENGTH 11.185 ENERGY 695.85 SPACING .002 SADDLE .04983

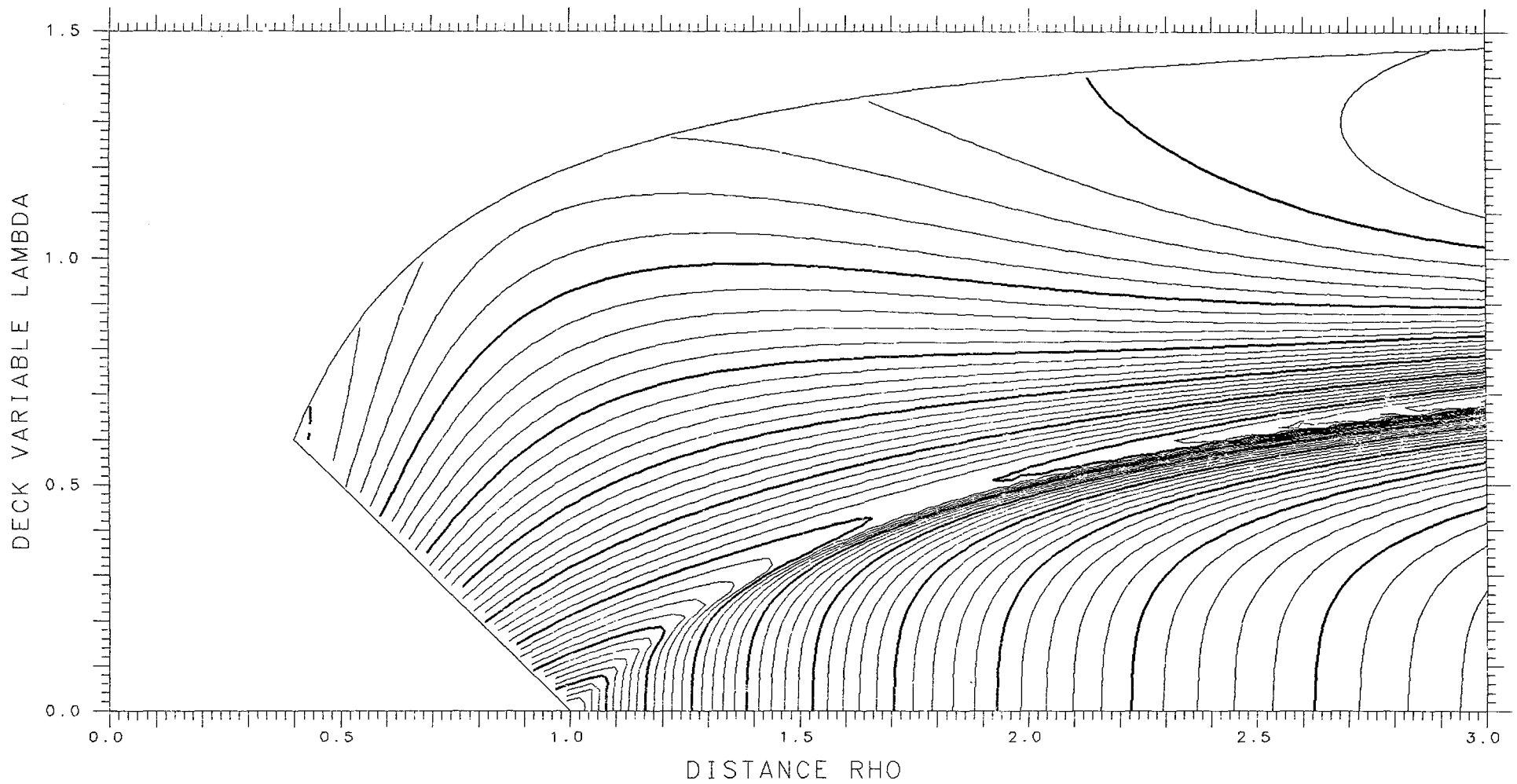

X= .500 ASYMMETRY DELTA= .475 FRACTIONAL= .9569

SPHERES .02848 TANGENT .07998 LENGTH 8.470 ENERGY 457.52 SPACING .005

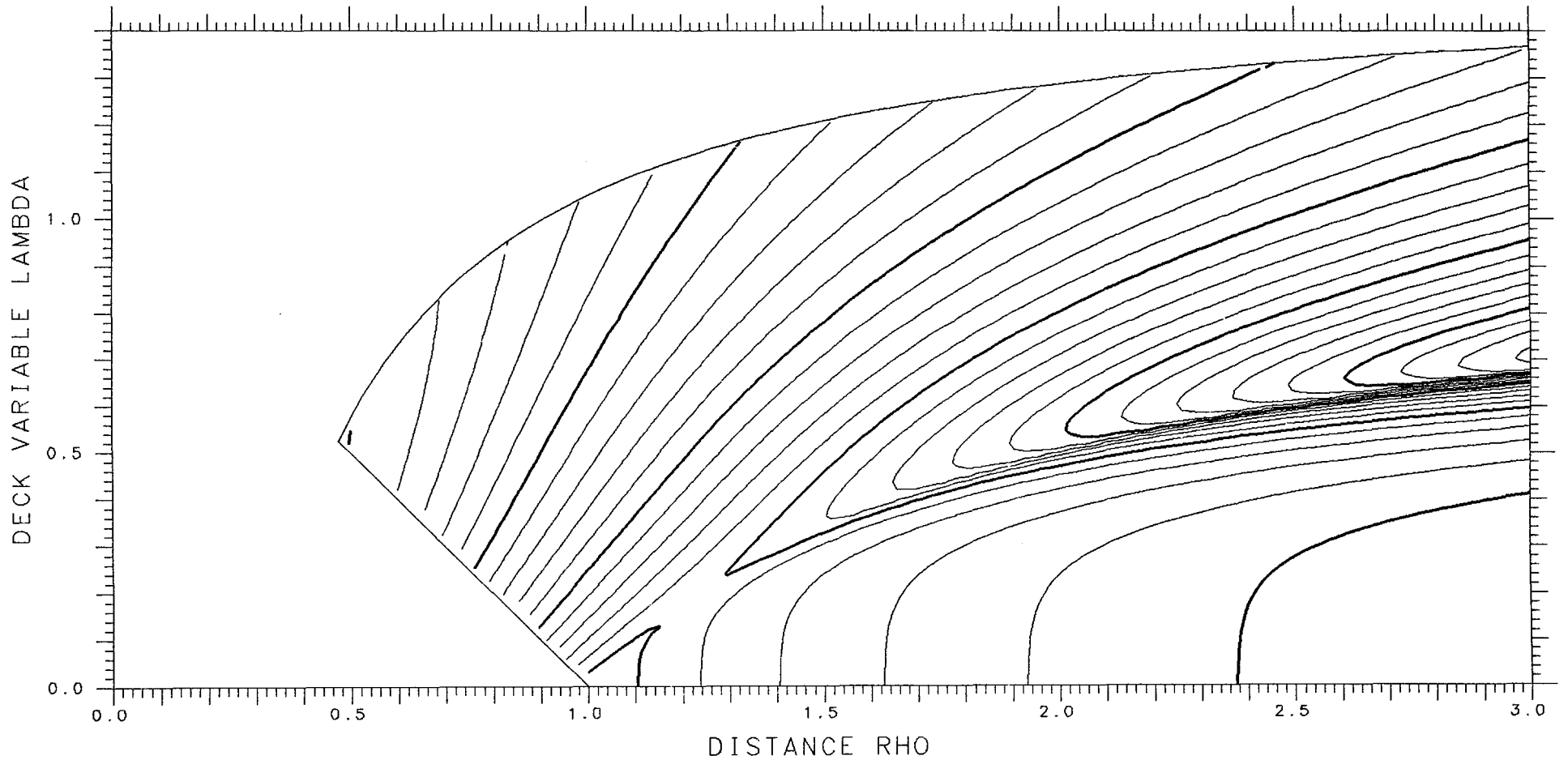

X= .900 ASYMMETRY DELTA= .375 FRACTIONAL= .9141

SPHERES -.08351 TANGENT .08327 LENGTH 11.336 ENERGY 695.85 SPACING .002 SADDLE .04535

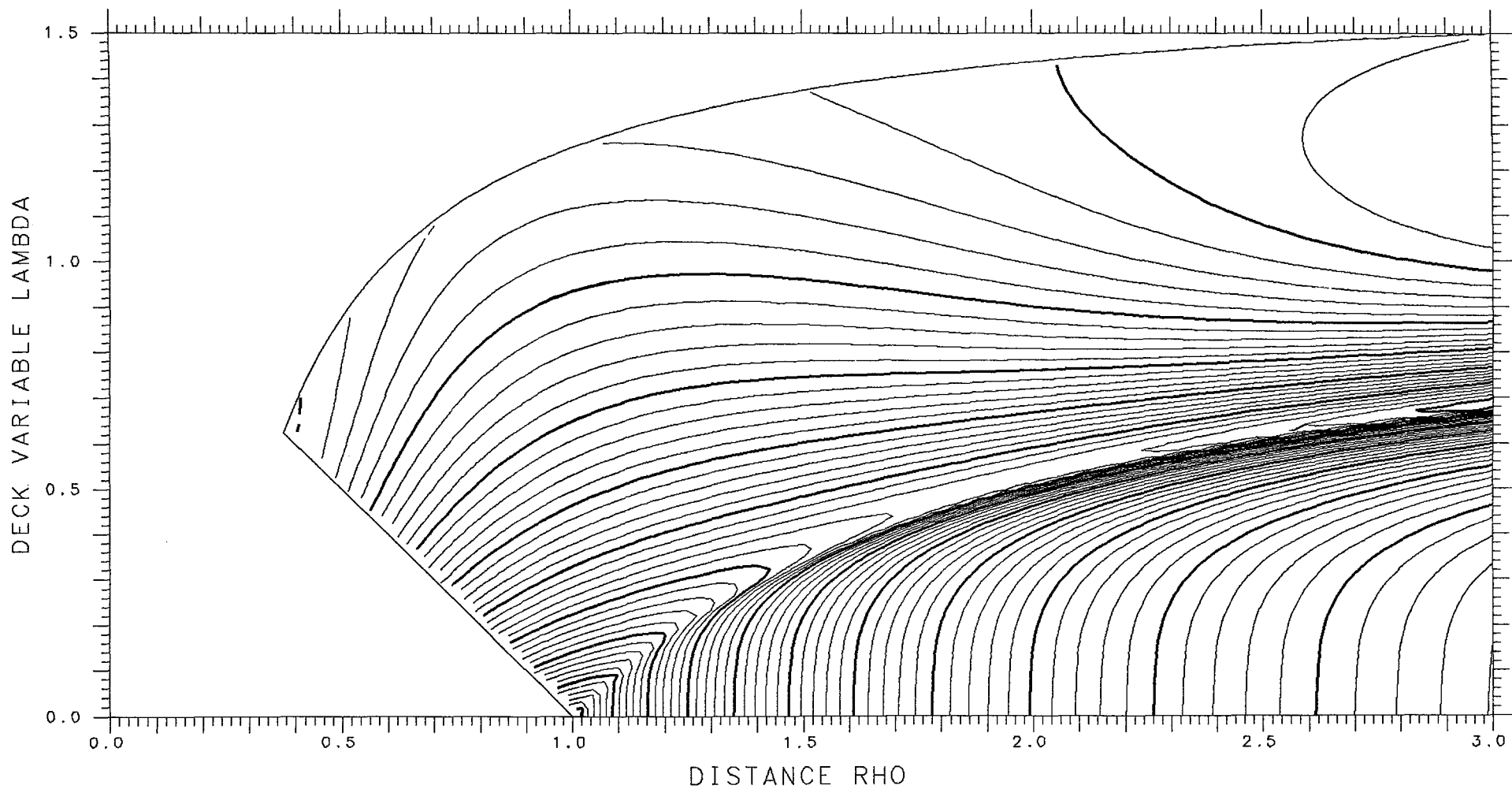

X= .500 ASYMMETRY DELTA= .500 FRACTIONAL= .9643

SPHERES .02956 TANGENT .07313 LENGTH 8.350 ENERGY 457.52 SPACING .005

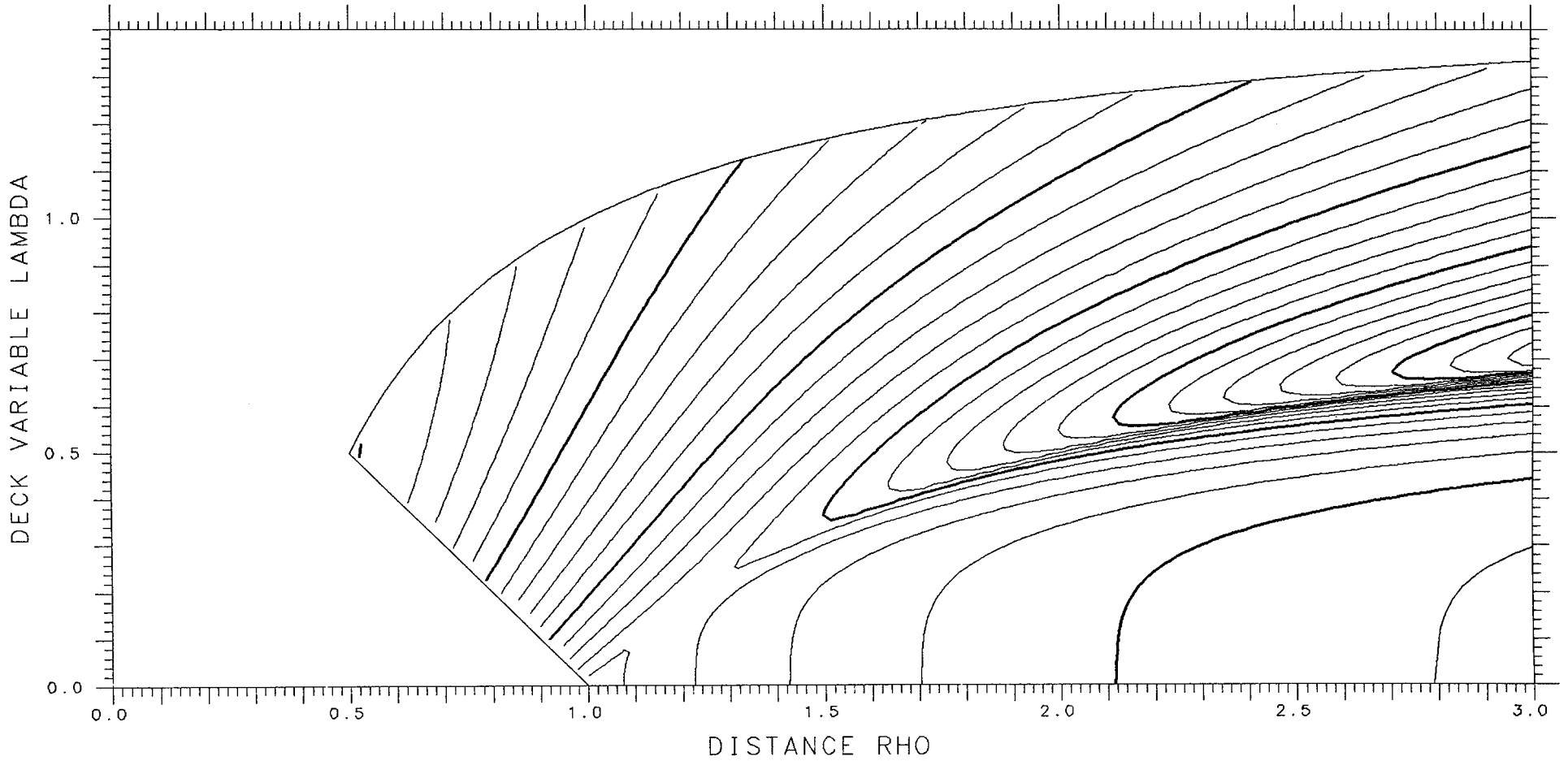

X= .900 ASYMMETRY DELTA= .350 FRACTIONAL= .8996

SPHERES -.10407 TANGENT .08541 LENGTH 11.484 ENERGY 695.85 SPACING .002 SADDLE .03917

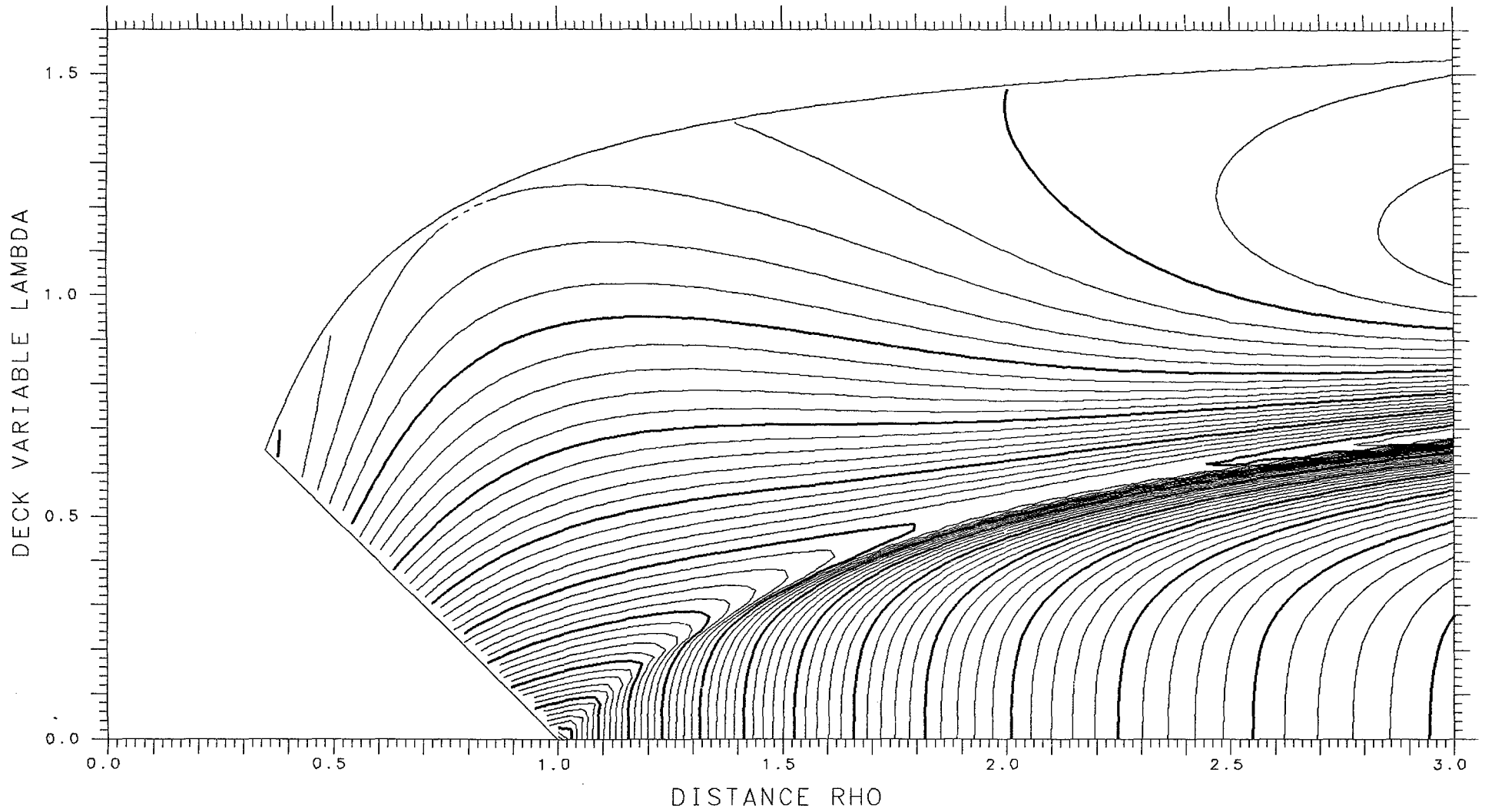

X= .500 ASYMMETRY DELTA= .525 FRACTIONAL= .9707

SPHERES .02984 TANGENT .06639 LENGTH 8.231 ENERGY 457.52 SPACING .005

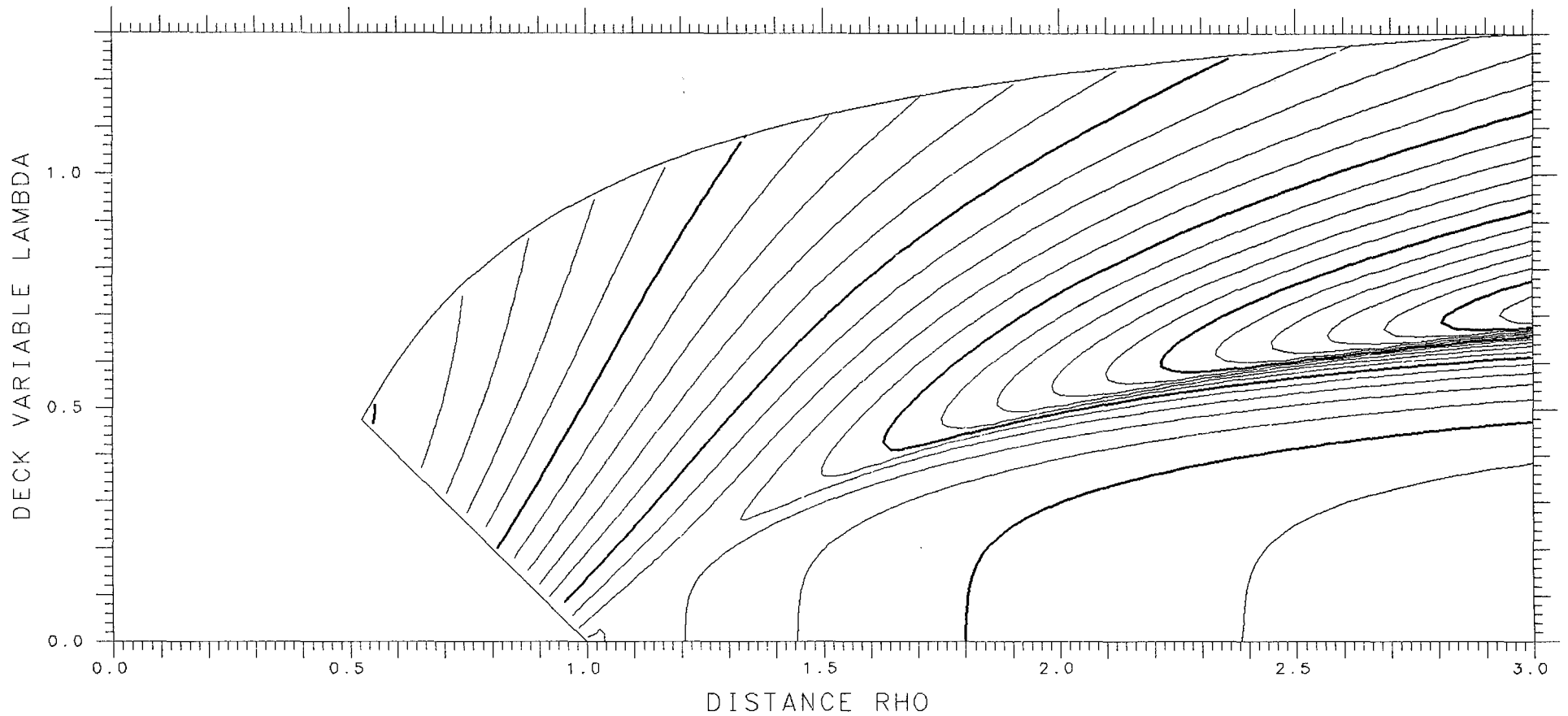

X= .900 ASYMMETRY DELTA= .325 FRACTIONAL= .8832

SPHERES -.12682 TANGENT .08682 LENGTH 11.629 ENERGY 695.85 SPACING .002 SADDLE .03135

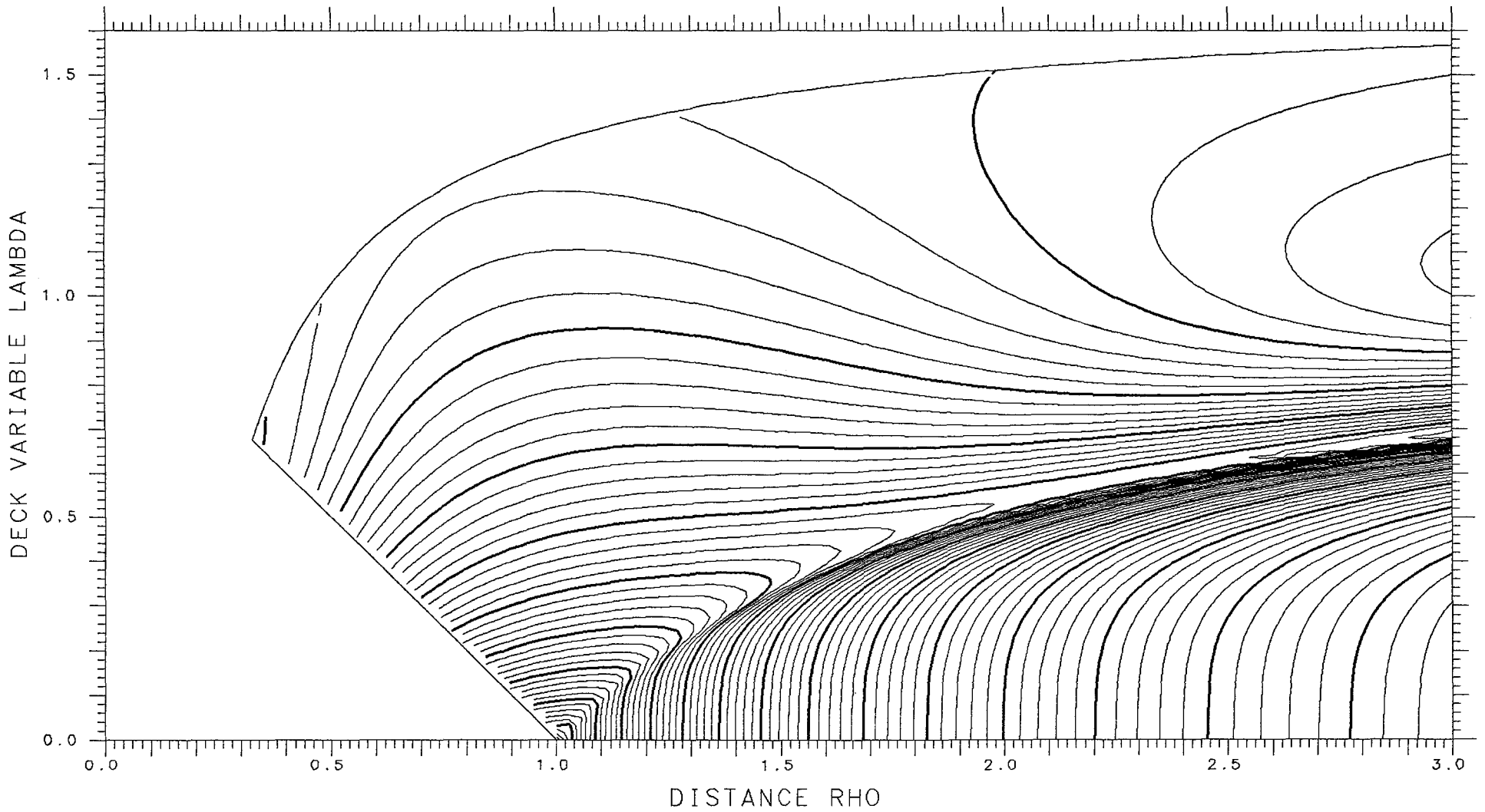

X= .550

ASYMMETRY DELTA=0.

FRACTIONAL= .5000

SPHERES -.14712

TANGENT .14161

LENGTH 10.456

ENERGY 490.53

SPACING .005

SADDLE .07796

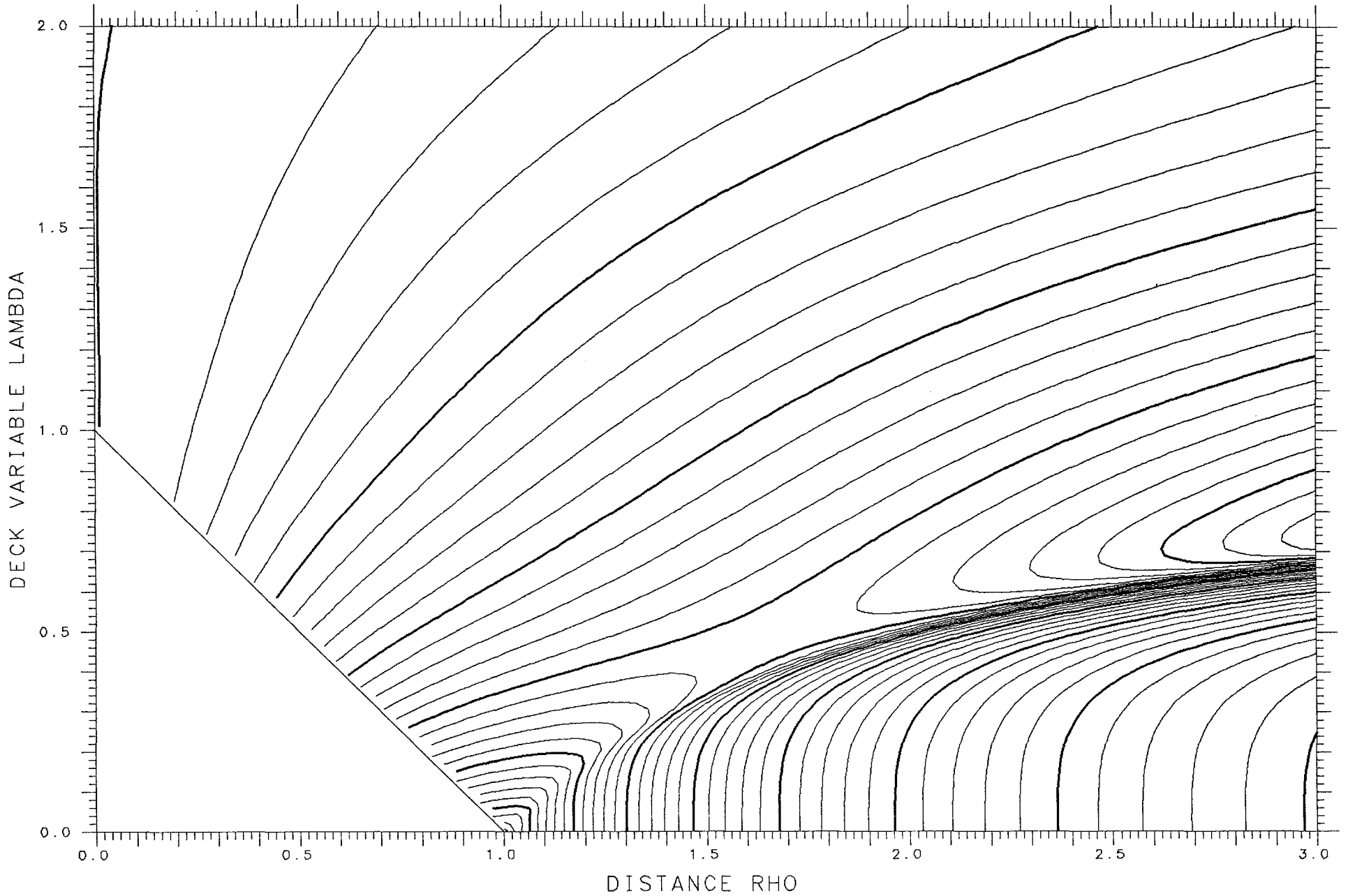

X= .900 ASYMMETRY DELTA= .300 FRACTIONAL= .8650

SPHERES -.15159 TANGENT .08746 LENGTH 11.771 ENERGY 695.85 SPACING .002 SADDLE .02206

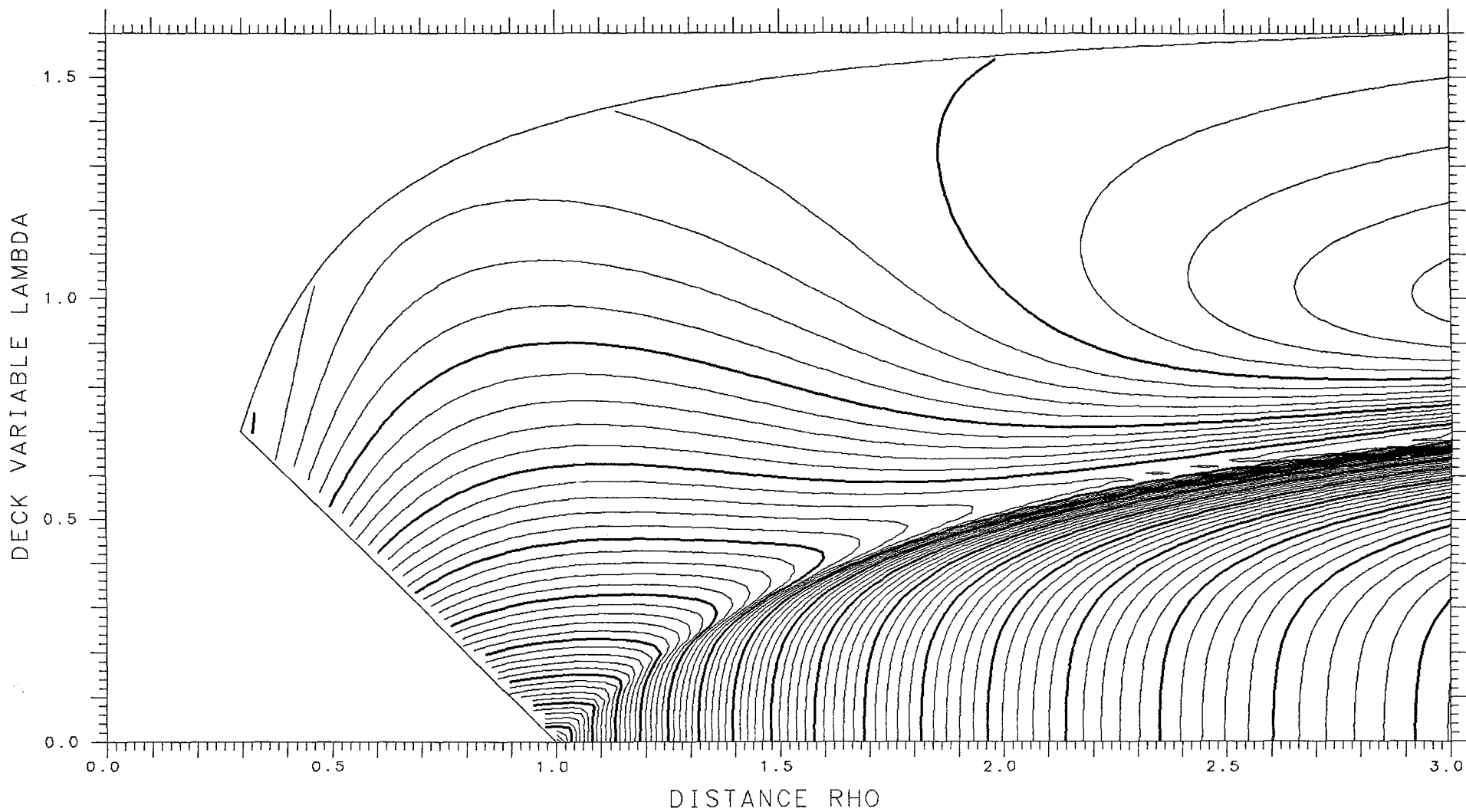

X= .550

ASYMMETRY DELTA= .025

FRACTIONAL= .5374

SPHERES -.14575

TANGENT .14154

LENGTH 10.450

ENERGY 490.53

SPACING .005

SADDLE .07826

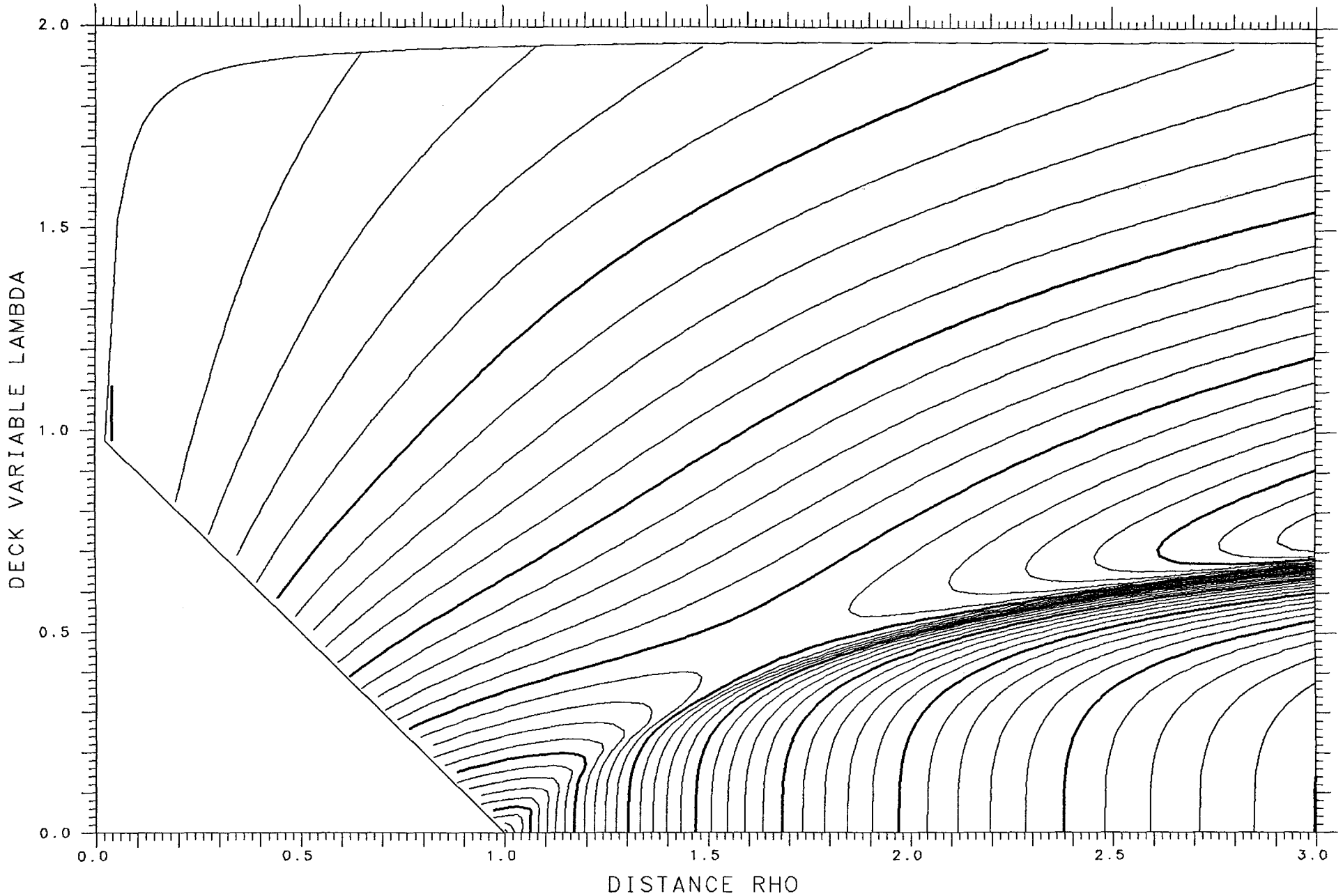

X= .900 ASYMMETRY DELTA= .275 FRACTIONAL= .8447

SPHERES -.17808 TANGENT .08733 LENGTH 11.907 ENERGY 695.85 SPACING .002 SADDLE .01152

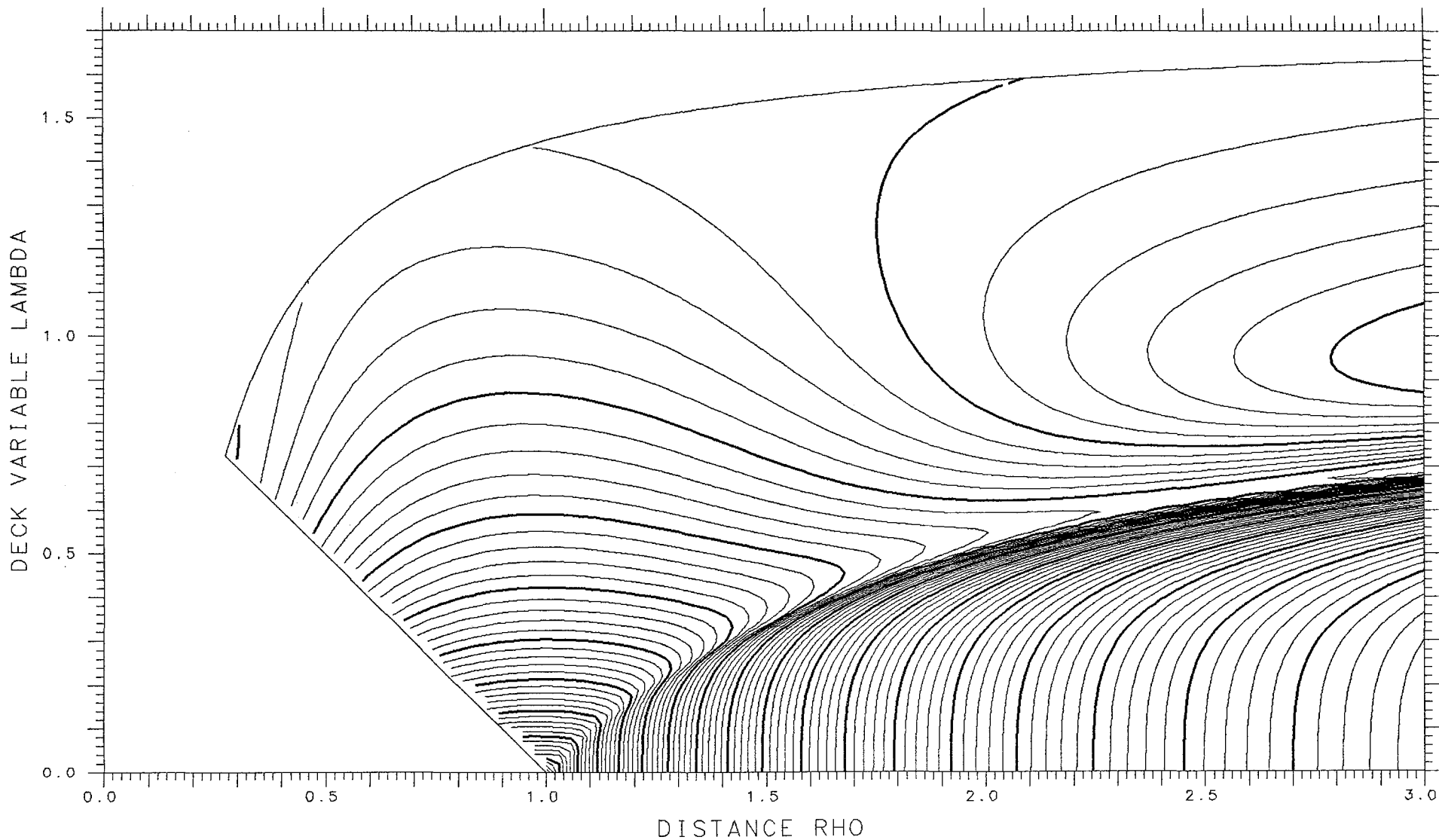

X= .550

ASYMMETRY DELTA= .050 FRACTIONAL= .5745

SPHERES -.14169

TANGENT .14133

LENGTH 10.430

ENERGY 490.53

SPACING .005

SADDLE .07913

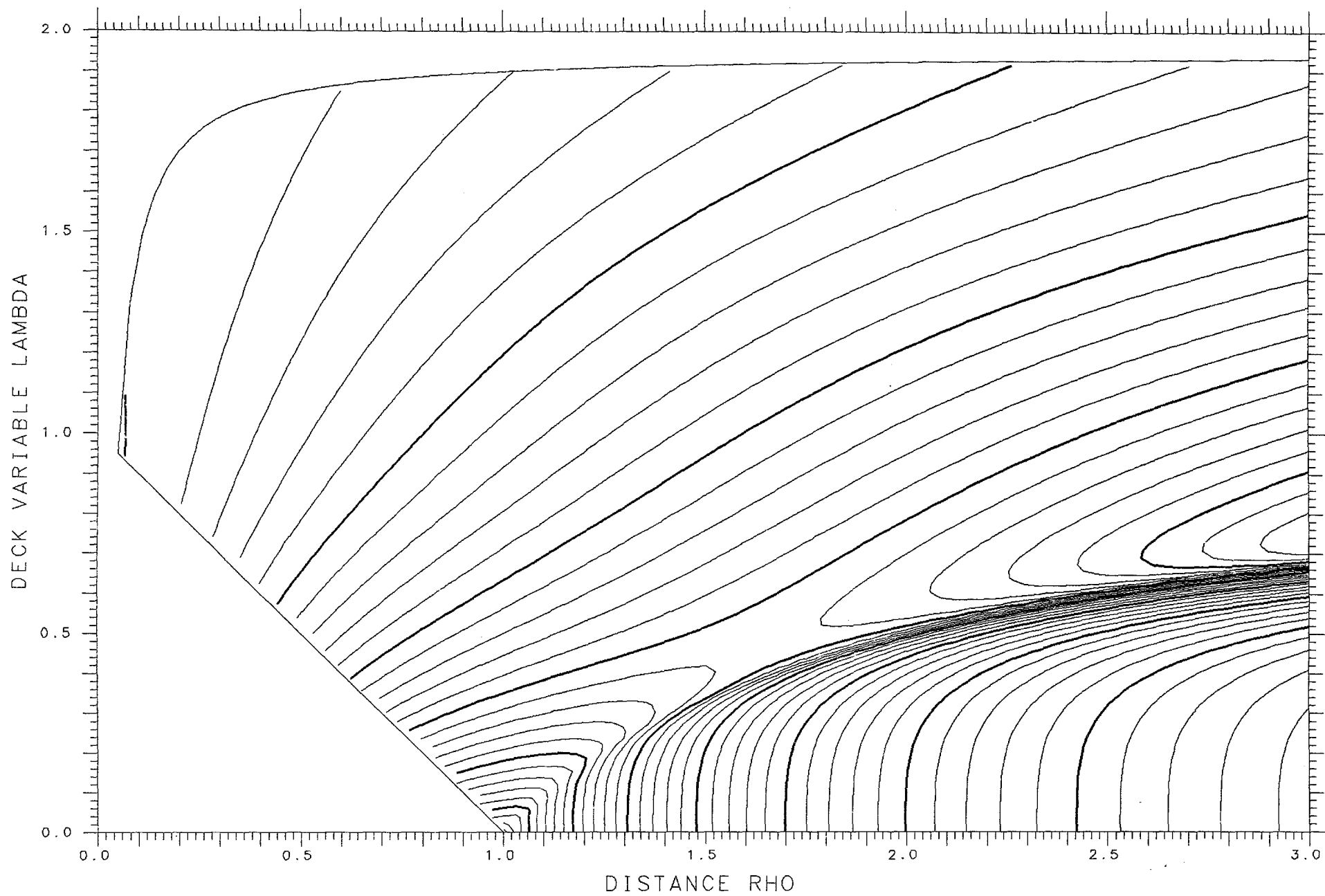

X = .900 ASYMMETRY DELTA = .250 FRACTIONAL = .8224

SPHERES - .20588 TANGENT .08646 LENGTH 12.037 ENERGY 695.85 SPACING .002 SADDLE .00004

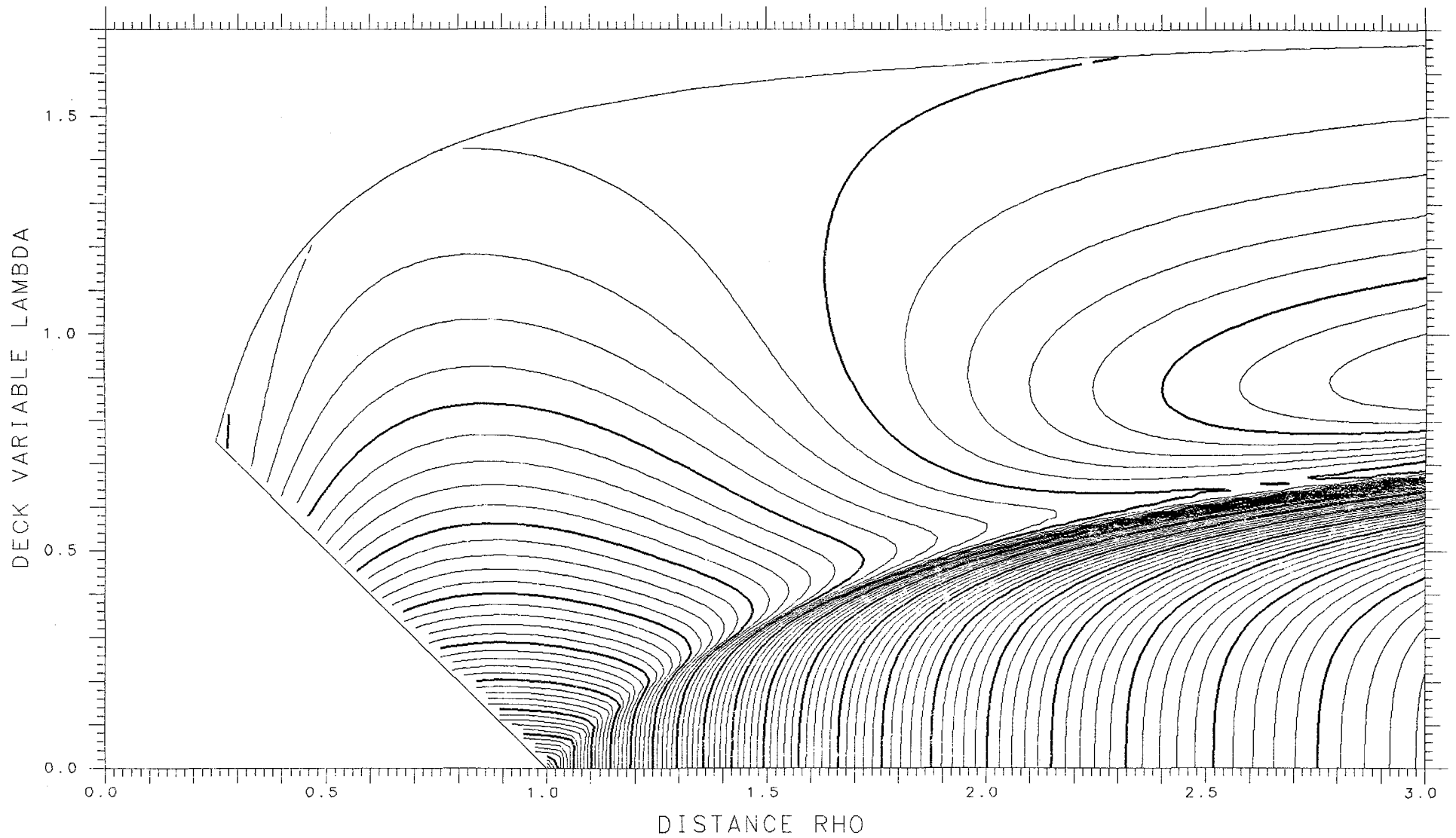

X= .550 ASYMMETRY DELTA= .075 FRACTIONAL= .6108

SPHERES -.13514 TANGENT .14094 LENGTH 10.398 ENERGY 490.53 SPACING .005 SADDLE .08052

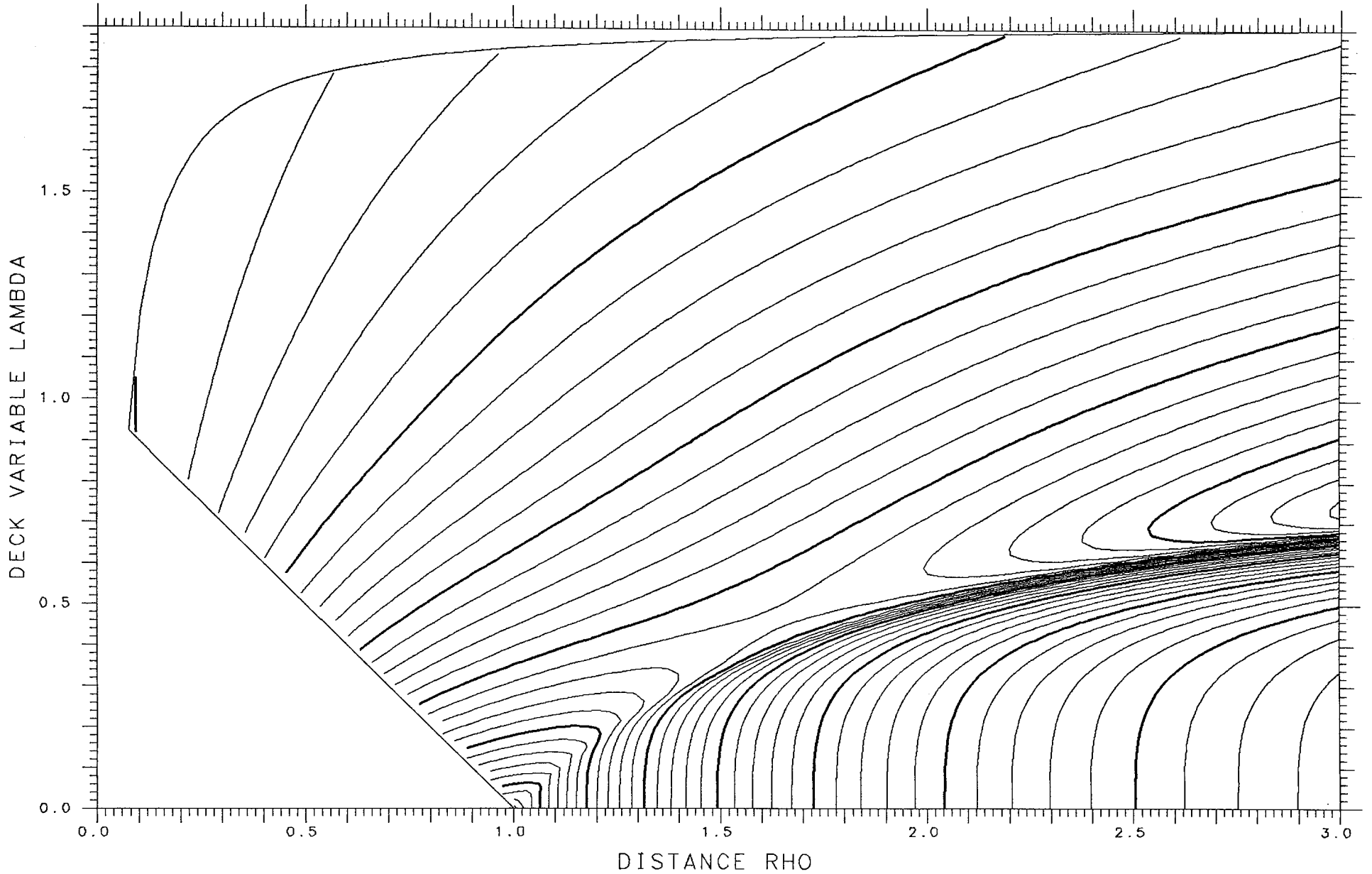

X= .900 ASYMMETRY DELTA= .225 FRACTIONAL= .7979

SPHERES -.23449 TANGENT .08492 LENGTH 12.160 ENERGY 695.85 SPACING .002 SADDLE -.01198

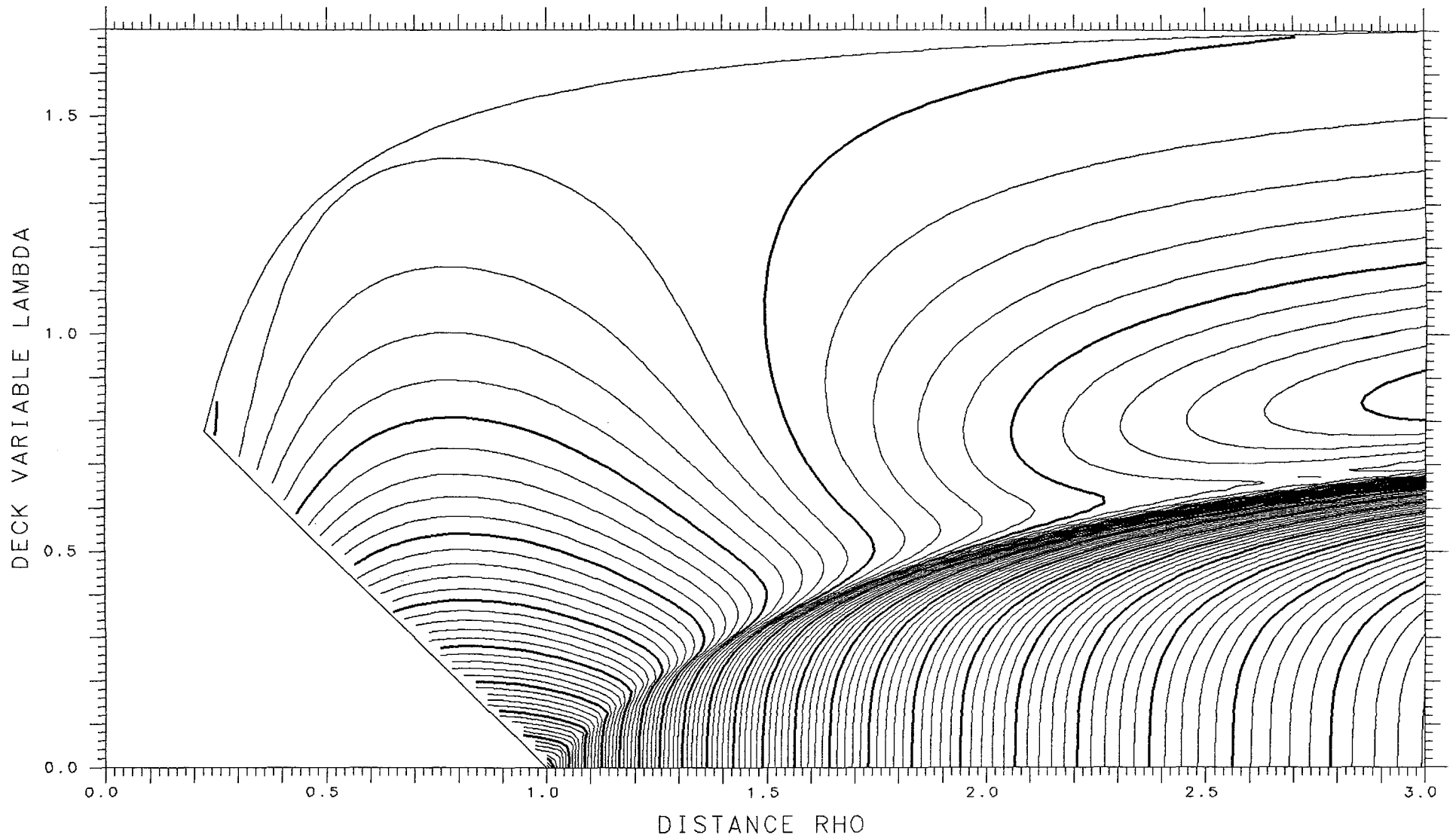

X= .550 ASYMMETRY DELTA= .100 FRACTIONAL= .6461

SPHERES -.12637 TANGENT .14032 LENGTH 10.354 ENERGY 490.53 SPACING .005 SADDLE .08235

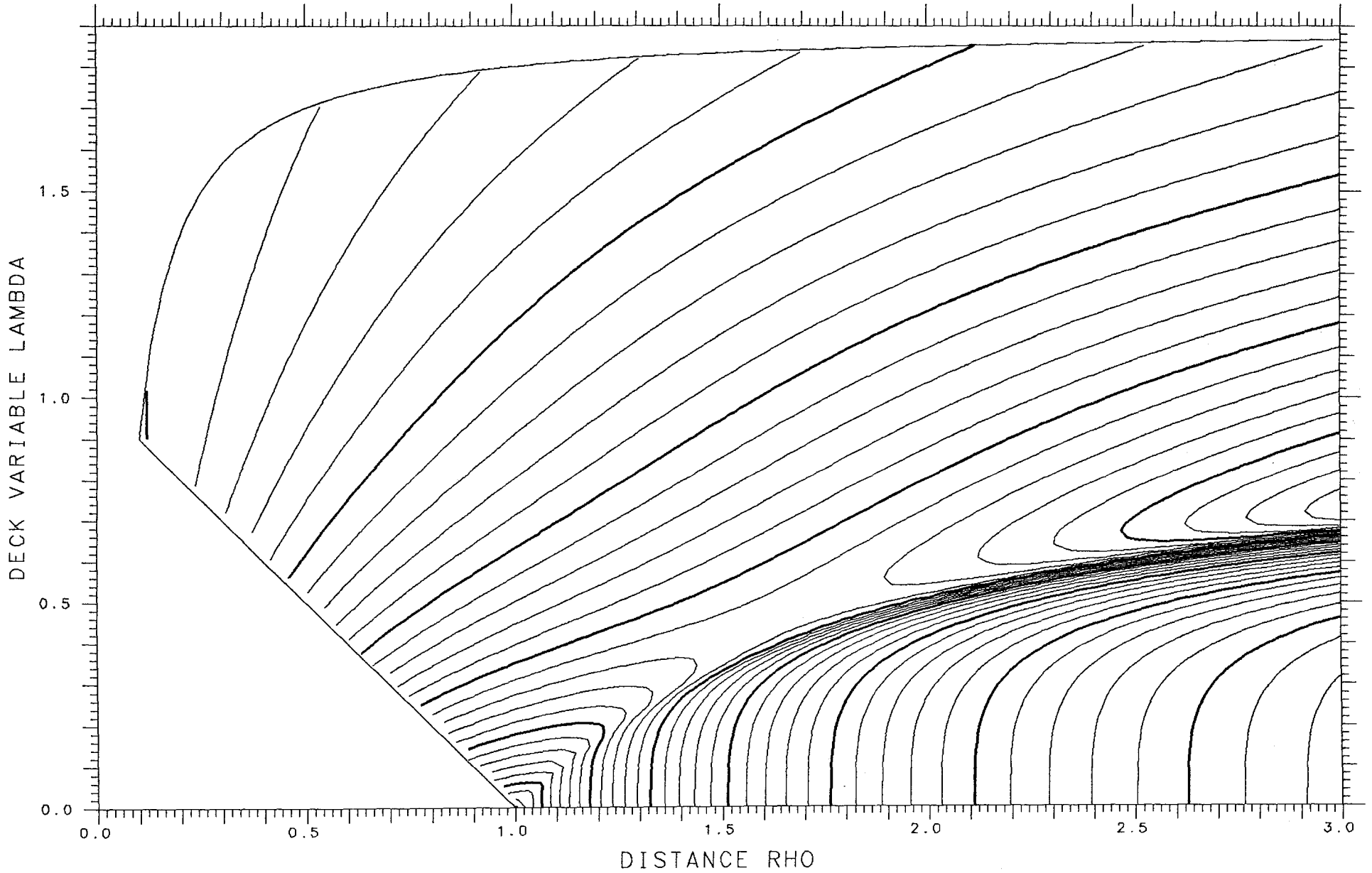

X= .900 ASYMMETRY DELTA= .200 FRACTIONAL= .7714

SPHERES -.26325 TANGENT .08281 LENGTH 12.274 ENERGY 695.85 SPACING .002 SADDLE -.02406

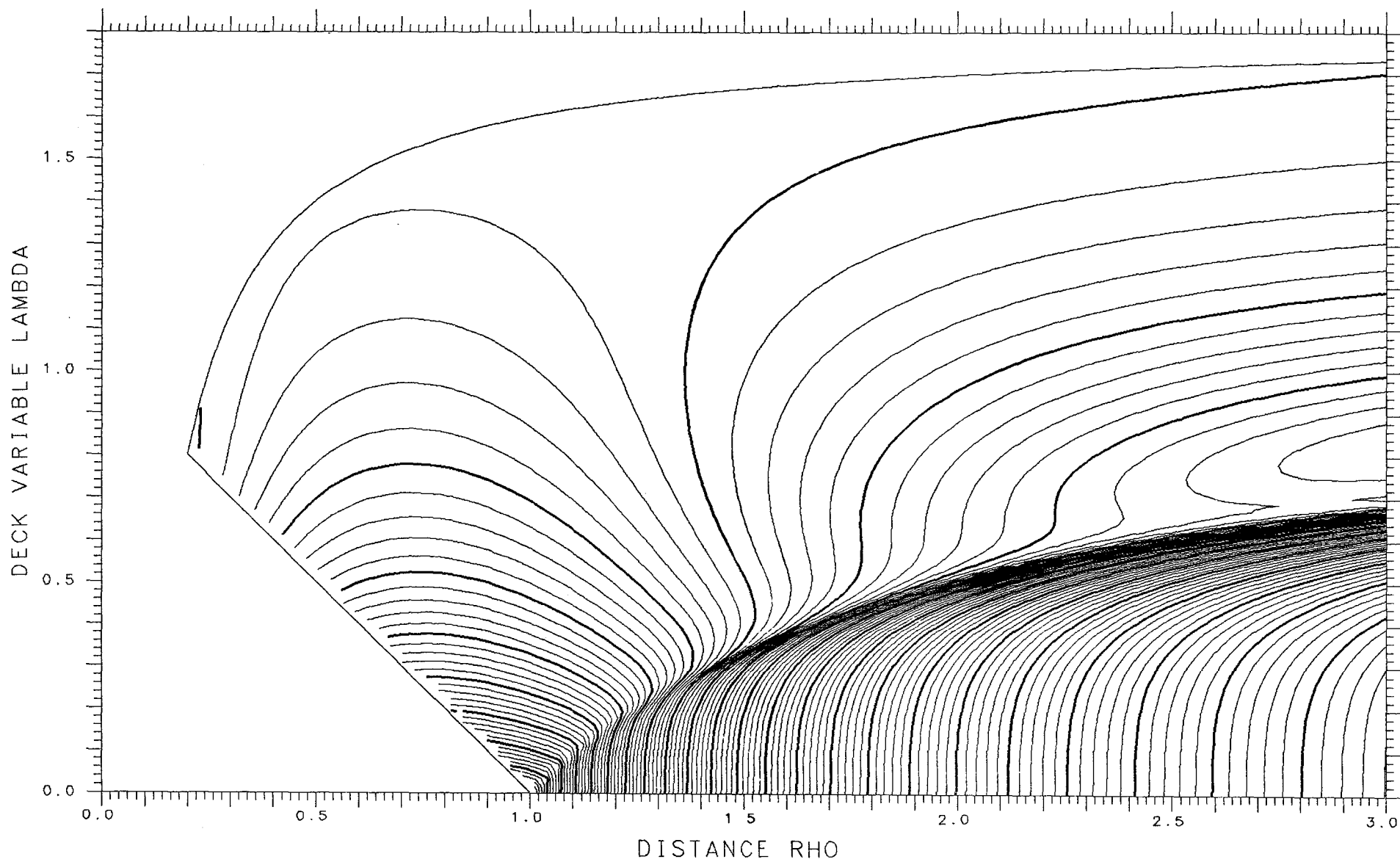

X= .550 ASYMMETRY DELTA= .125 FRACTIONAL= .6800

SPHERES -.11576 TANGENT .13940 LENGTH 10.298 ENERGY 490.53 SPACING .005 SADDLE .08448

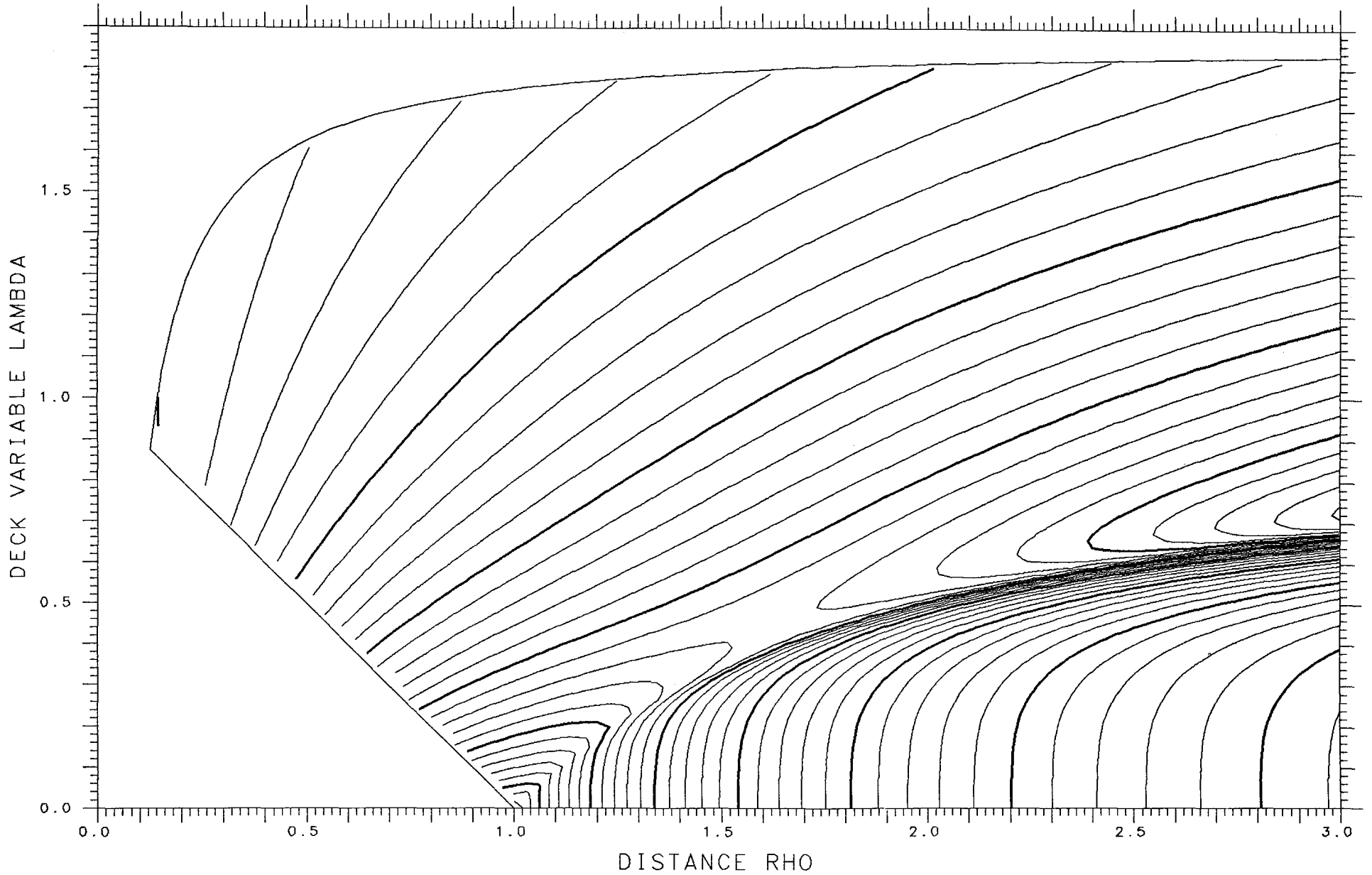

X= .900 ASYMMETRY DELTA= .175 FRACTIONAL= .7429

SPHERES -.29145 TANGENT .08028 LENGTH 12.379 ENERGY 695.85 SPACING .002 SADDLE -.03552

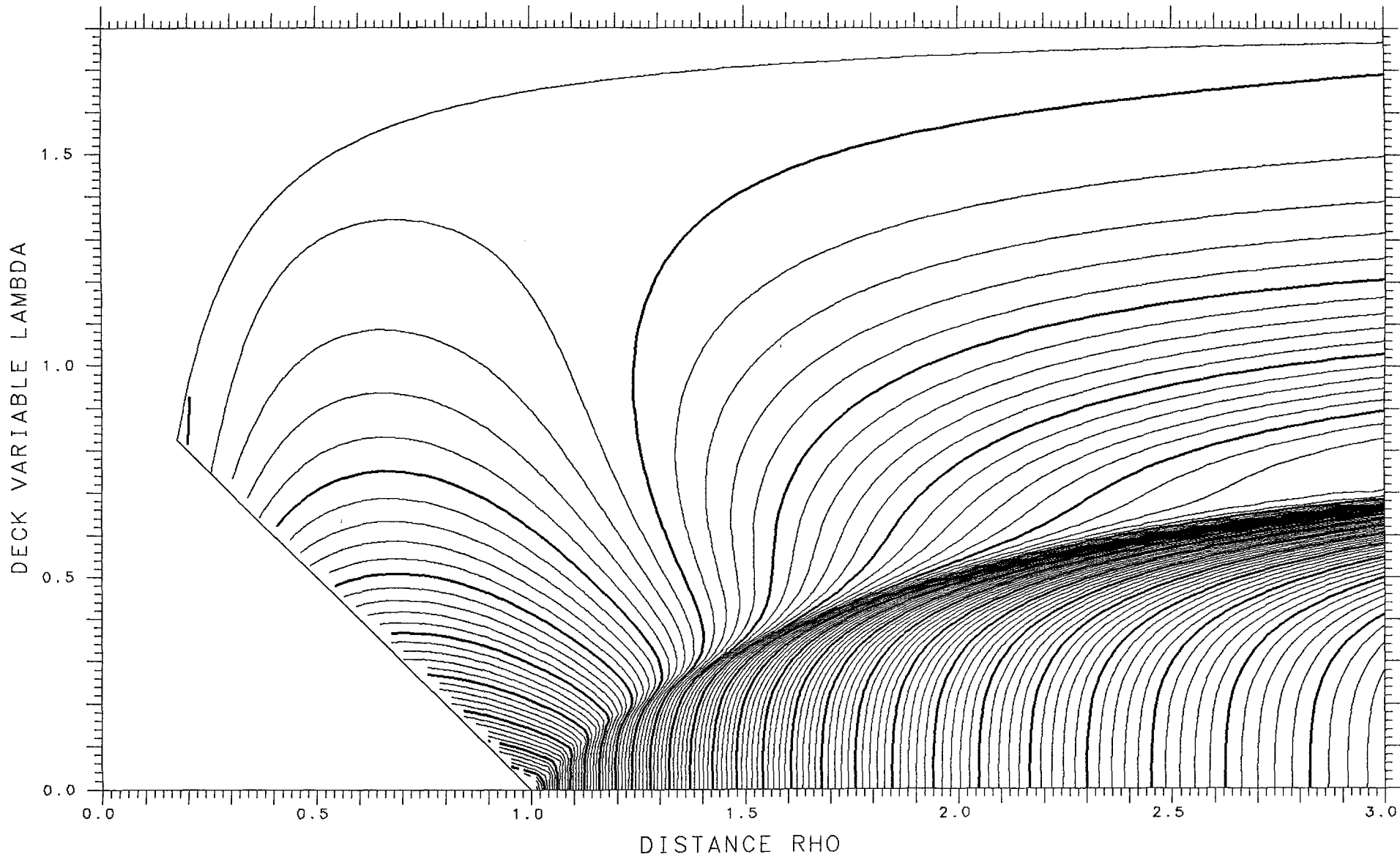

X= .550 ASYMMETRY DELTA= .150 FRACTIONAL= .7124

SPHERES -.10374 TANGENT .13812 LENGTH 10.231 ENERGY 490.53 SPACING .005 SADDLE .08677

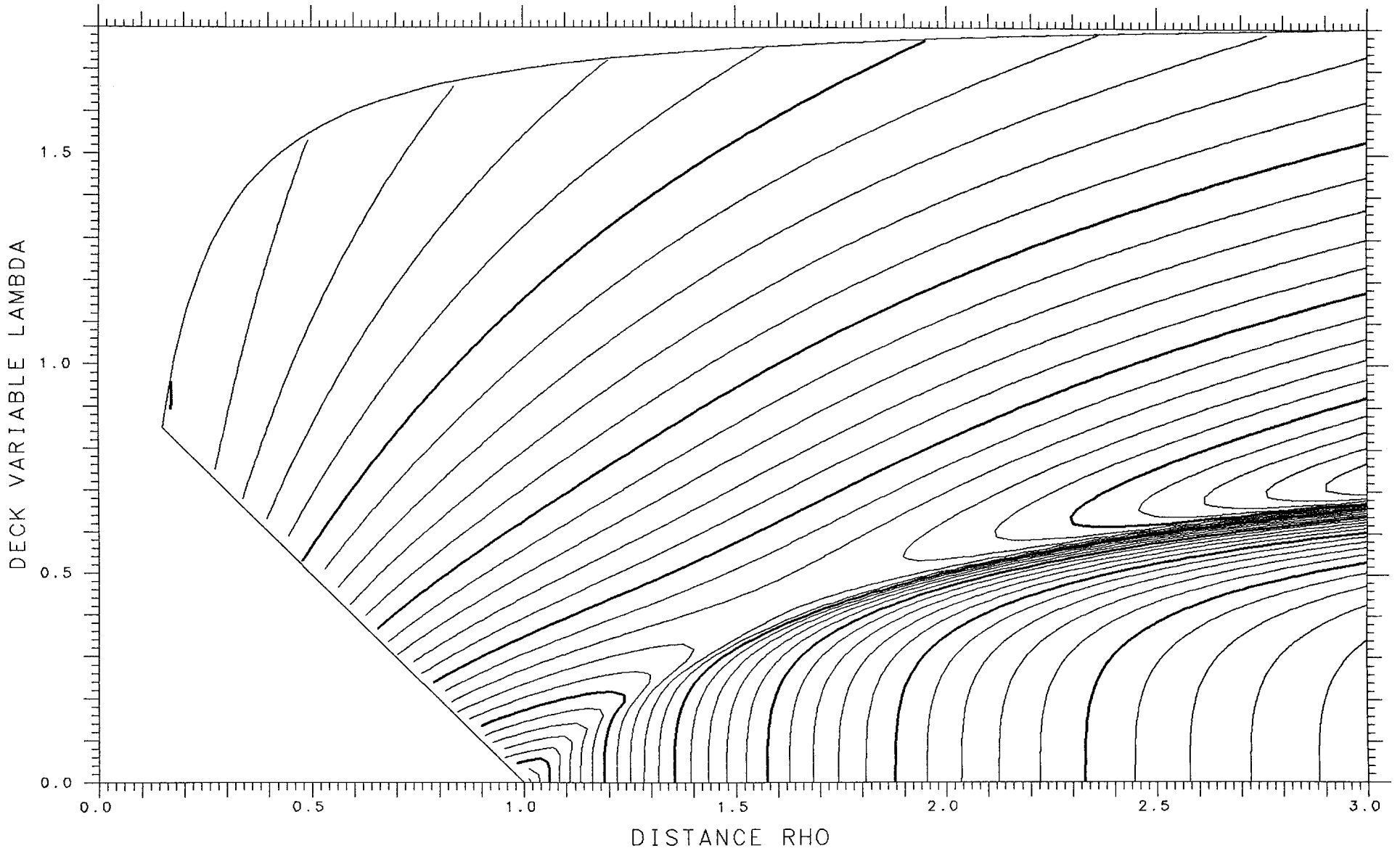

X= .900 ASYMMETRY DELTA= .150 FRACTIONAL= .7124

SPHERES -.31827 TANGENT .07750 LENGTH 12.472 ENERGY 695.85 SPACING .002 SADDLE .00102

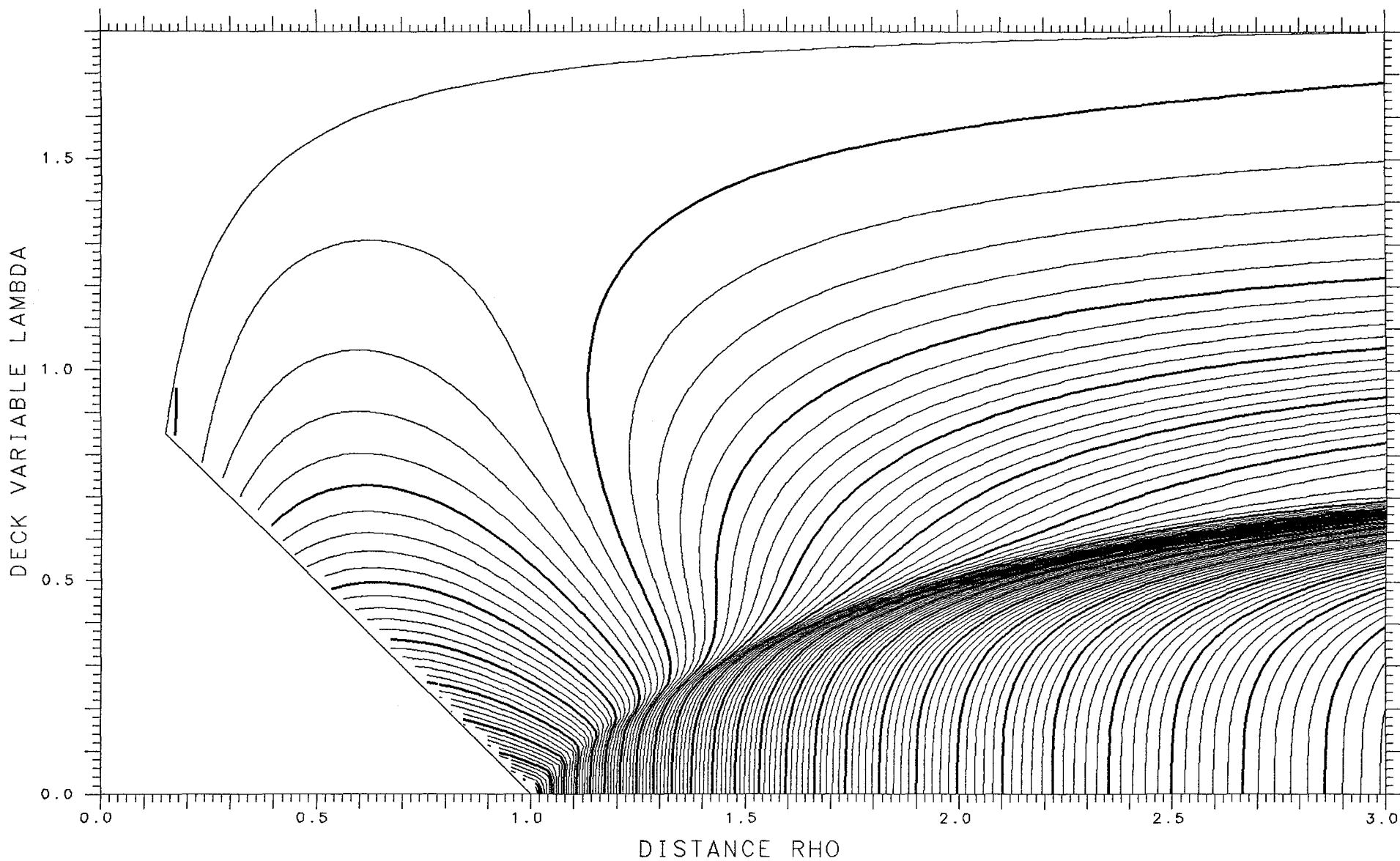

X= .550 ASYMMETRY DELTA= .175 FRACTIONAL= .7429

SPHERES -.09076 TANGENT .13641 LENGTH 10.154 ENERGY 490.53 SPACING .005 SADDLE .08904

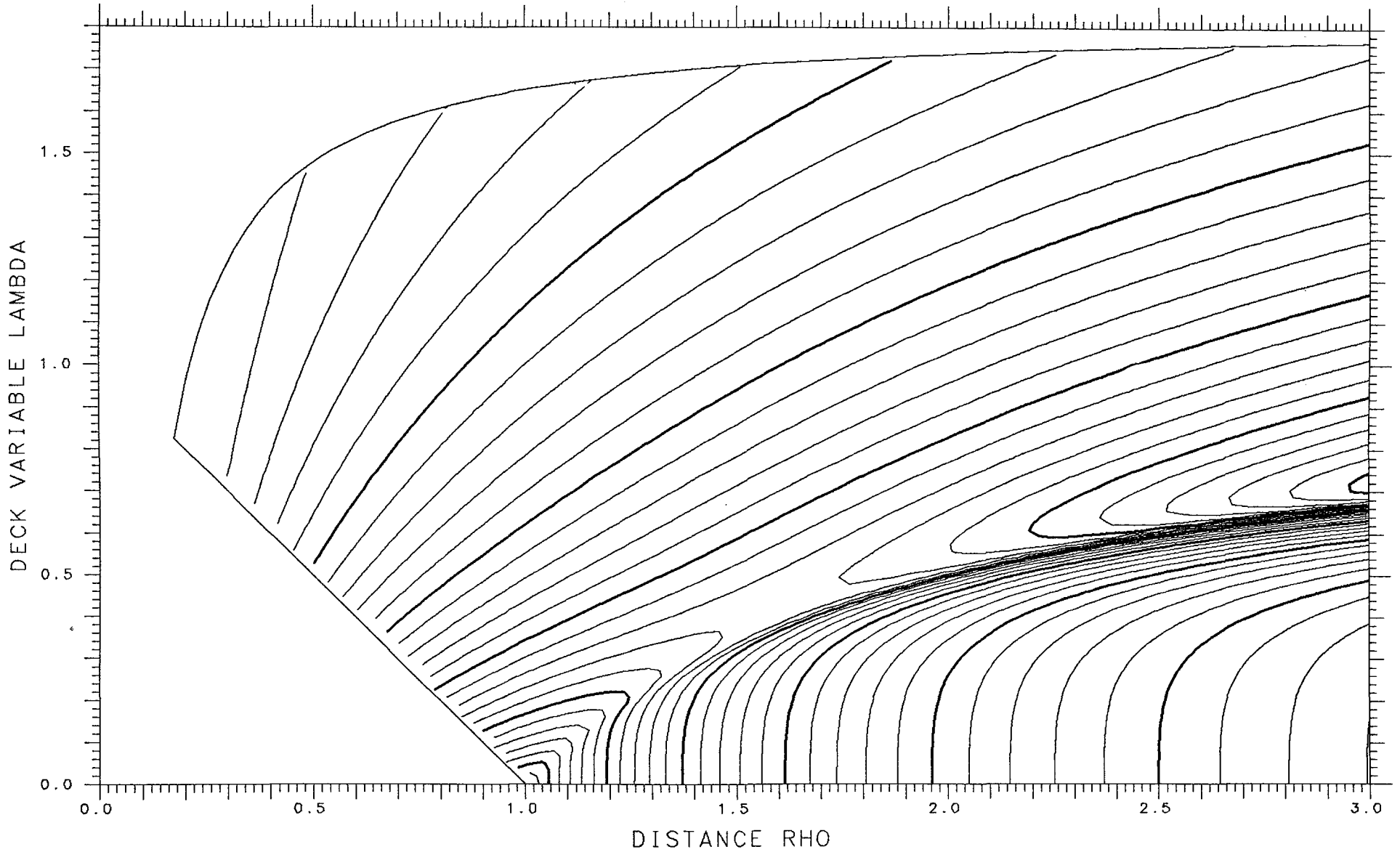

X= .900 ASYMMETRY DELTA= .125 FRACTIONAL= .6800

SPHERES -.34287 TANGENT .07467 LENGTH 12.554 ENERGY 695.85 SPACING .002 SADDLE .00102

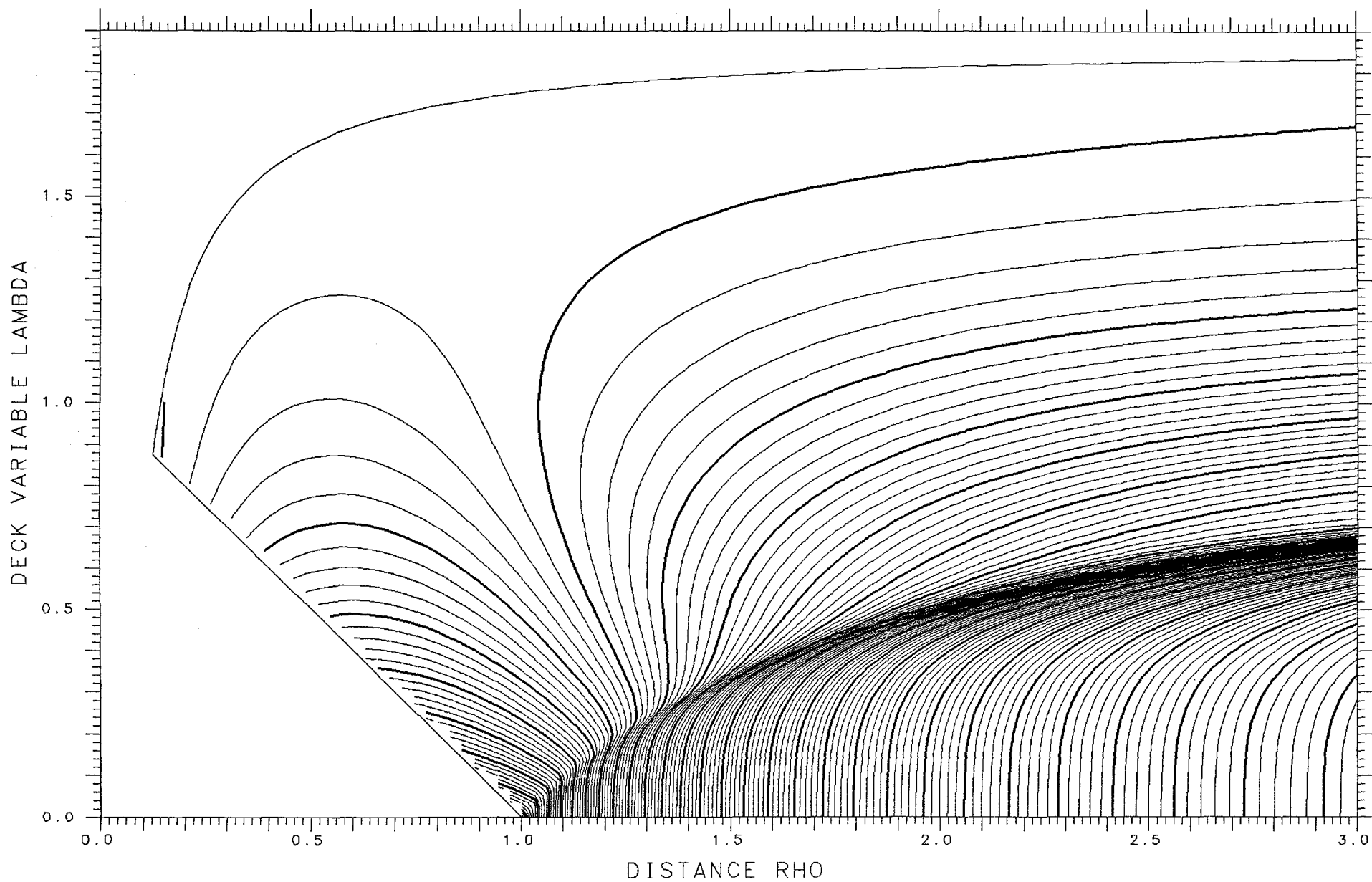

X= .550 ASYMMETRY DELTA= .200 FRACTIONAL= .7714

SPHERES -.07728 TANGENT .13421 LENGTH 10.069 ENERGY 490.53 SPACING .005 SADDLE .09110

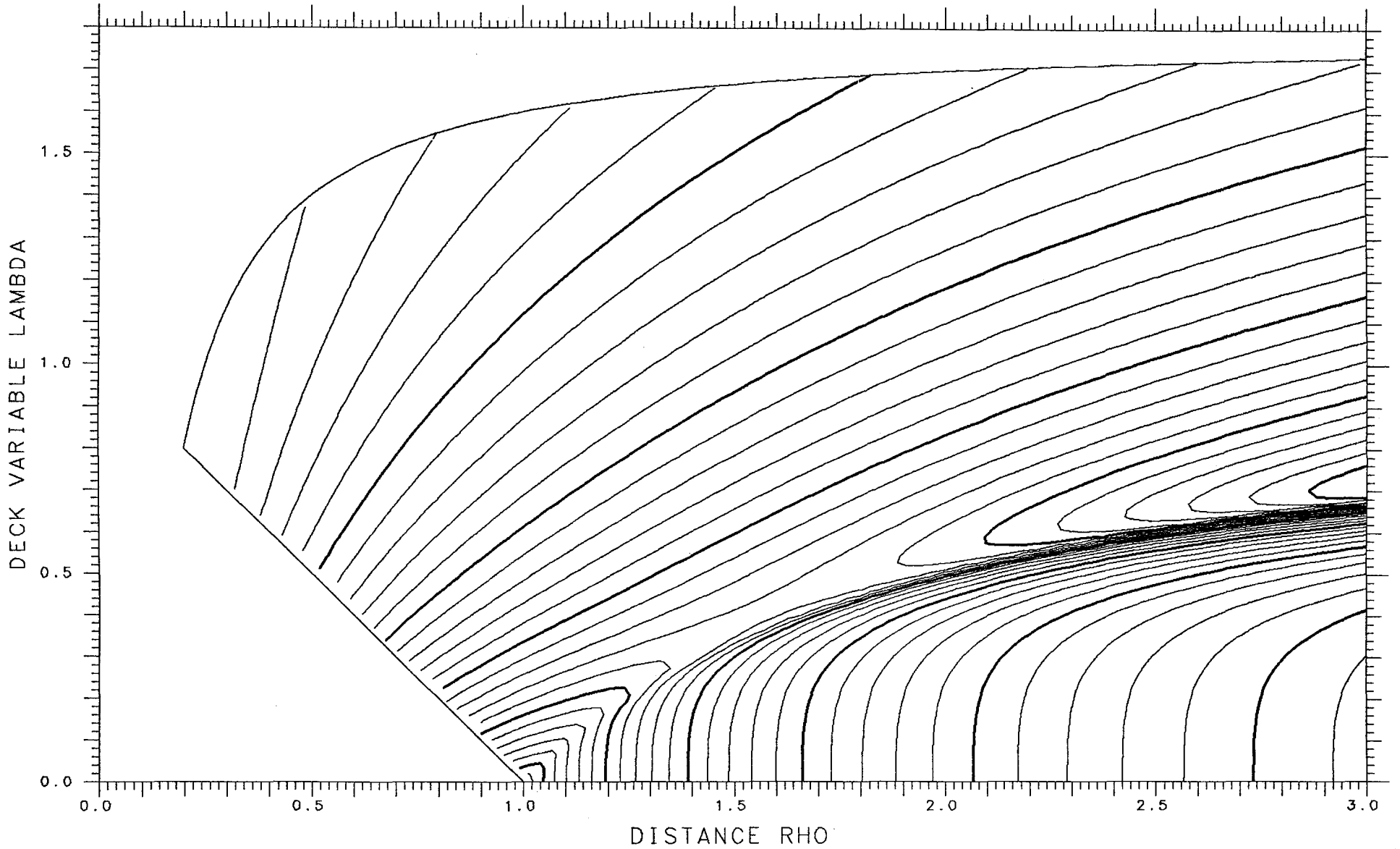

X= .900

ASYMMETRY DELTA= .100

FRACTIONAL= .6461

SPHERES -.36441

TANGENT .07199

LENGTH 12.622

ENERGY 695.85

SPACING .002

SADDLE .00100

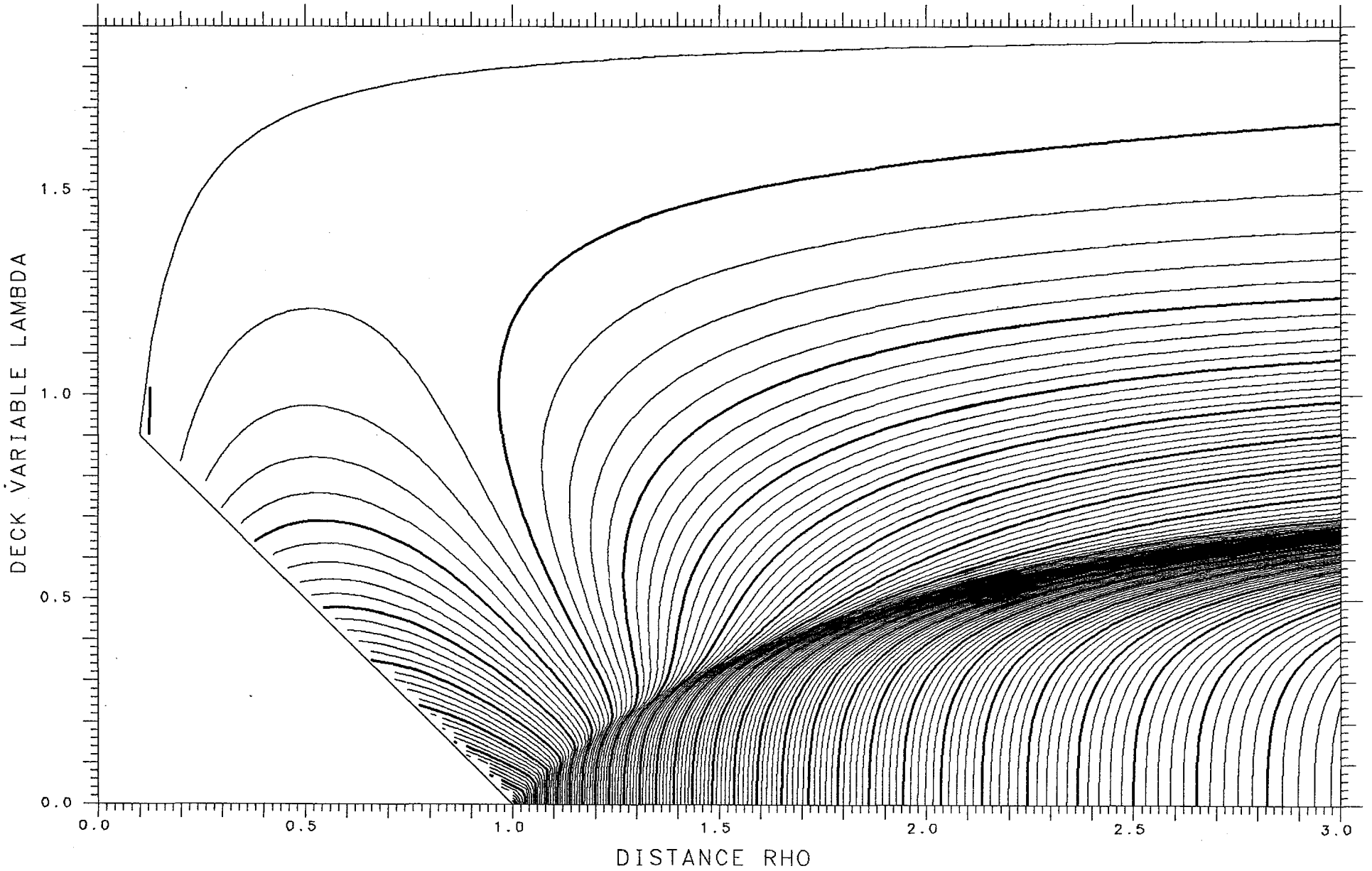

X= .550 ASYMMETRY DELTA= .225 FRACTIONAL= .7979

SPHERES -.06372 TANGENT .13147 LENGTH 9.975 ENERGY 490.53 SPACING .005 SADDLE .09278

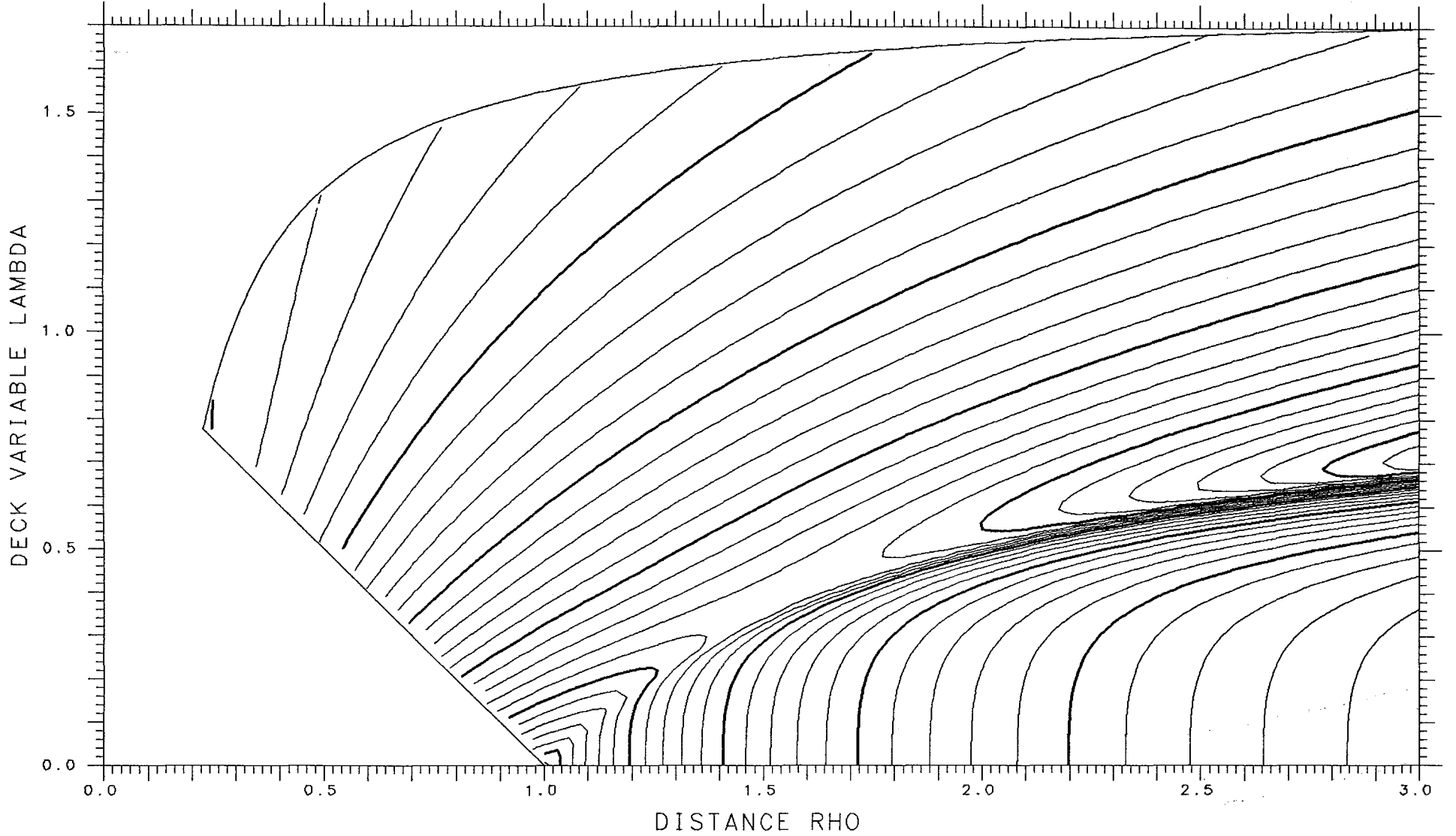

X= .900

ASYMMETRY DELTA= .075

FRACTIONAL= .6108

SPHERES -.38210

TANGENT .06966

LENGTH 12.676

ENERGY 695.85

SPACING .002

SADDLE .00096

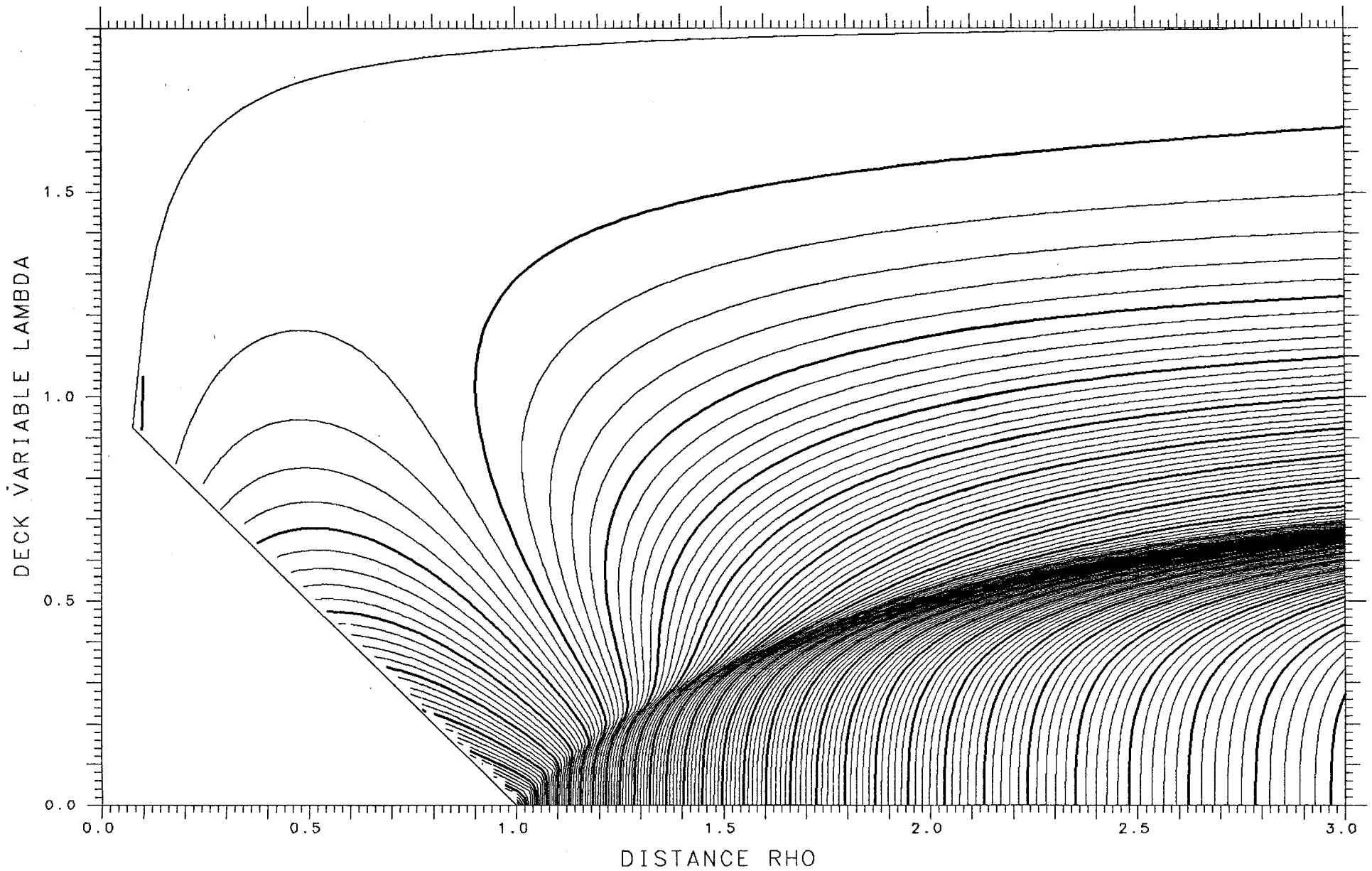

X= .550 ASYMMETRY DELTA= .250 FRACTIONAL= .8224

SPHERES -.05047 TANGENT .12819 LENGTH 9.874 ENERGY 490.53 SPACING .005 SADDLE .09393

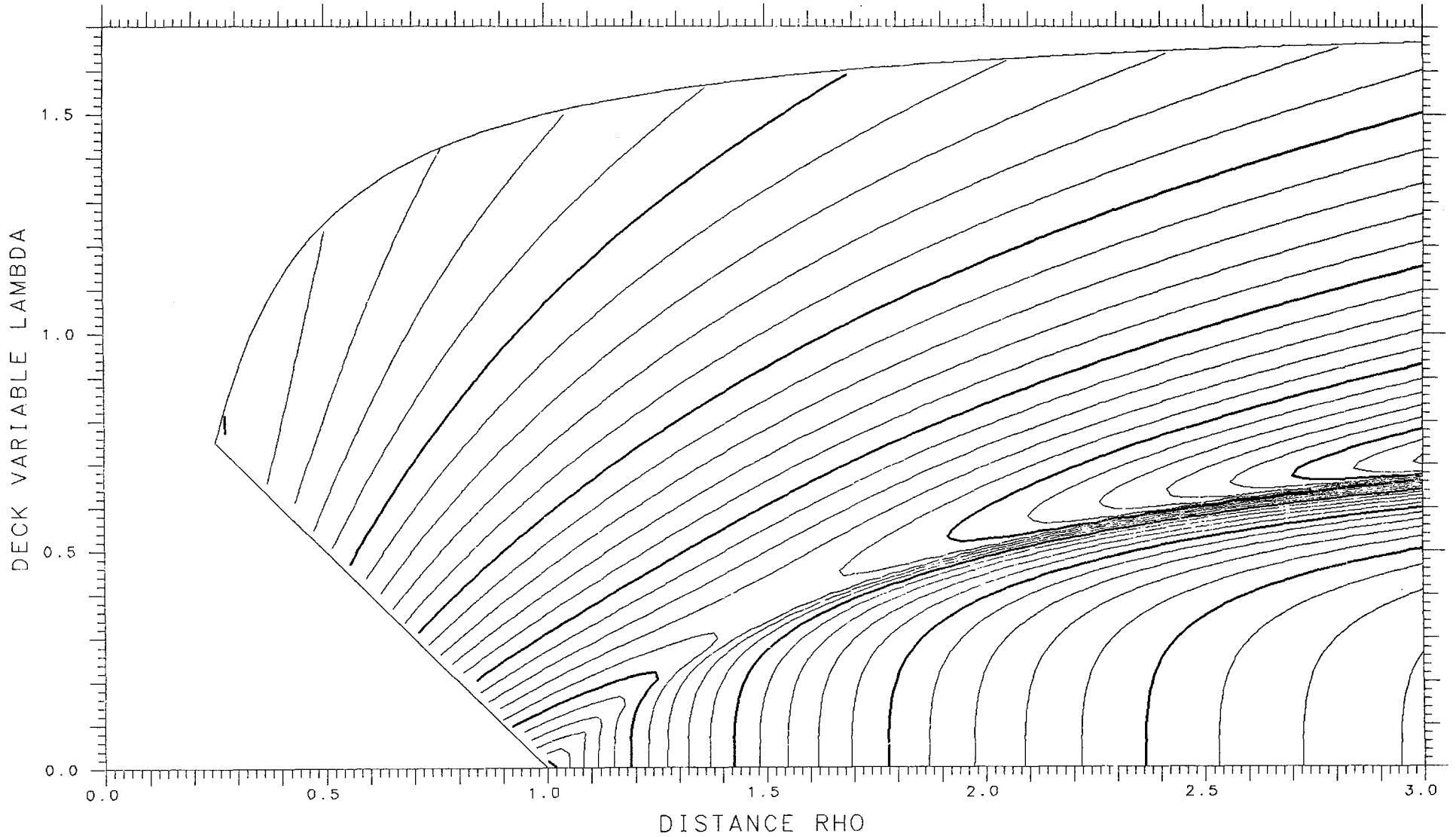

X = .900 ASYMMETRY DELTA = .050 FRACTIONAL = .5745

SPHERES - .39528 TANGENT .06785 LENGTH 12.715 ENERGY 695.85 SPACING .002 SADDLE .00090

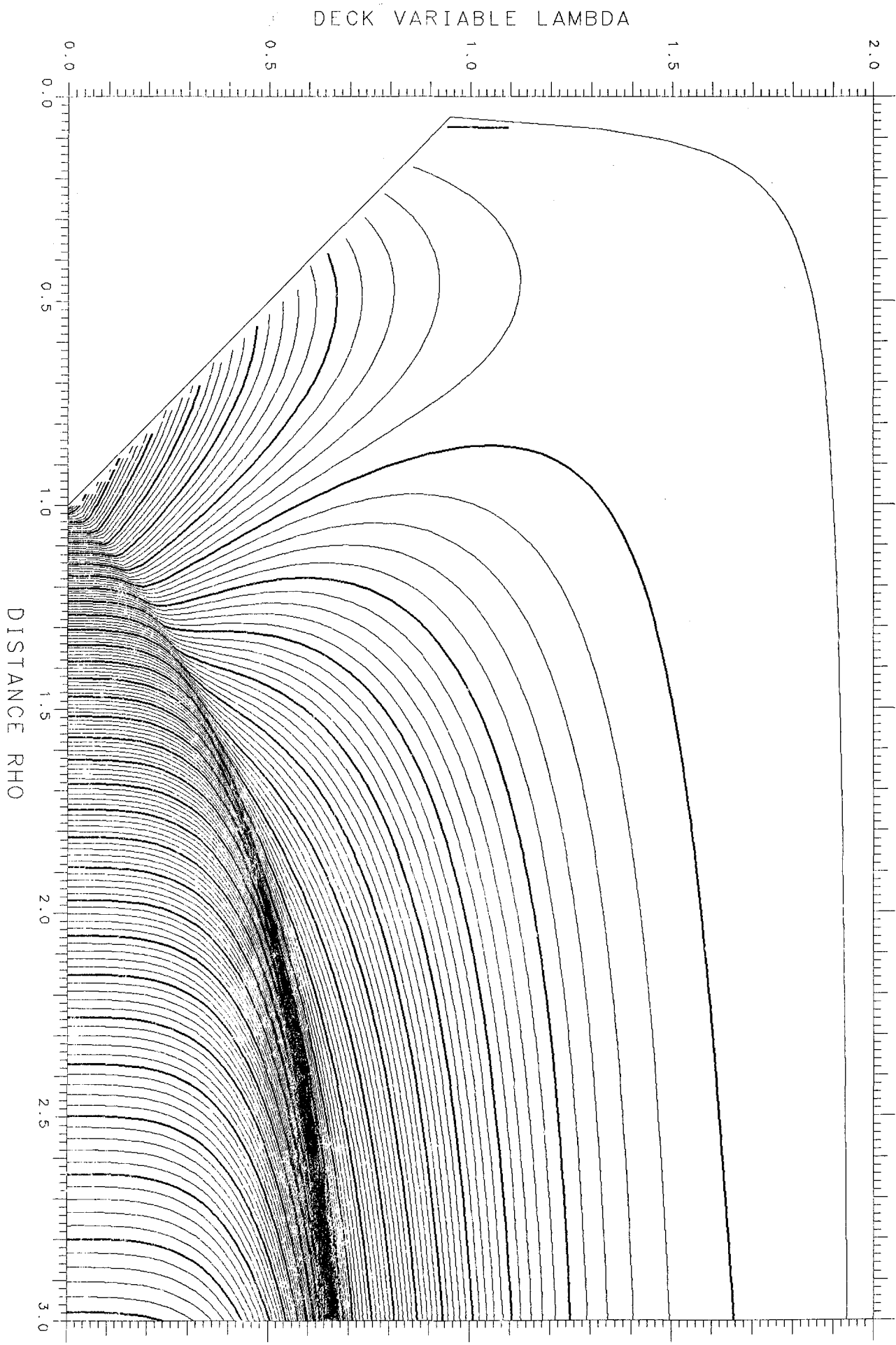

X= .550 ASYMMETRY DELTA= .275 FRACTIONAL= .8447

SPHERES -.03785 TANGENT .12435 LENGTH 9.767 ENERGY 490.53 SPACING .005 SADDLE .09443

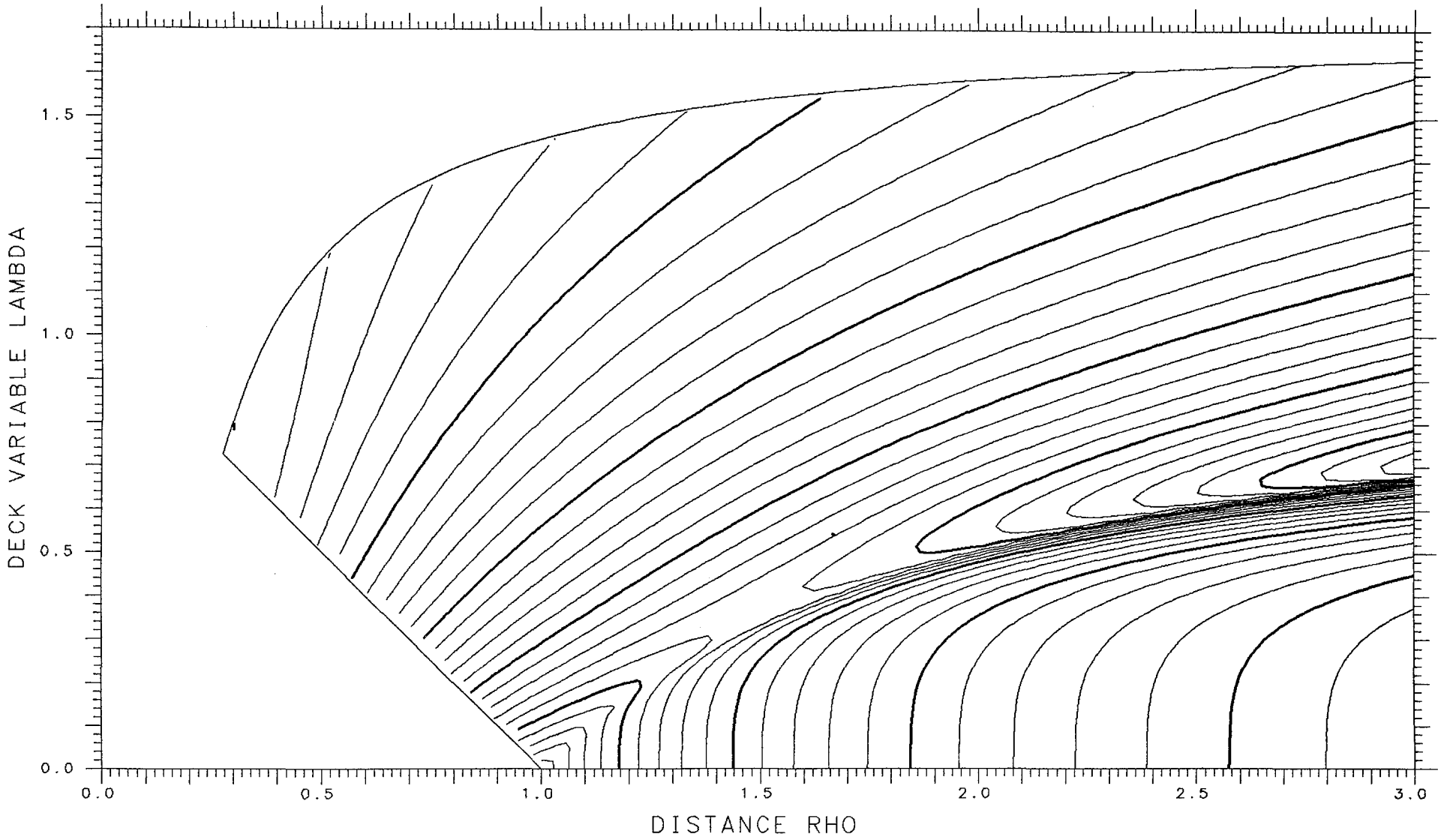

X= .900

ASYMMETRY DELTA= .025

FRACTIONAL= .5374

SPHERES -.40340

TANGENT .06671

LENGTH 12.739

ENERGY 695.85

SPACING .002

SADDLE .00085

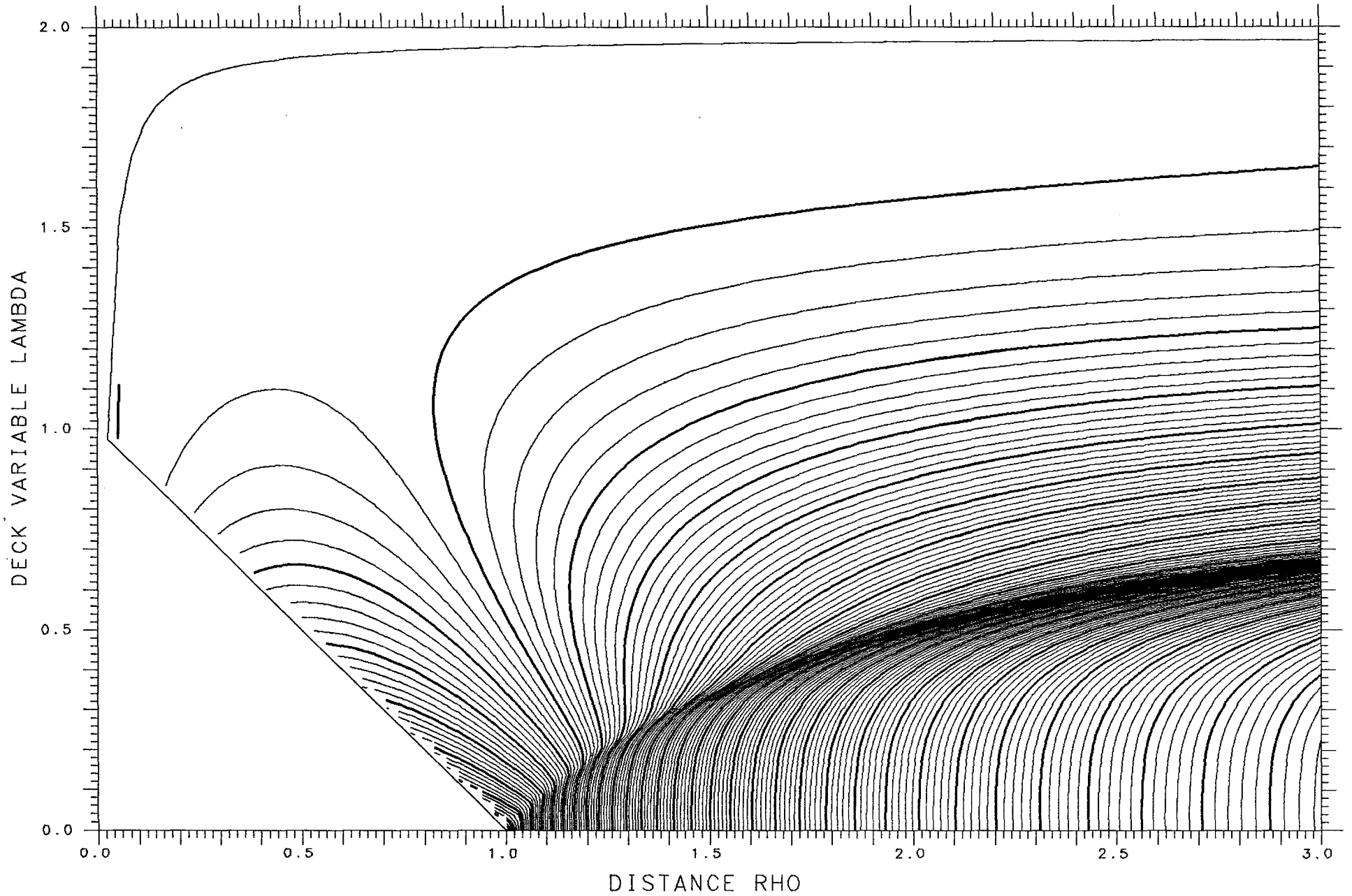

X= .550 ASYMMETRY DELTA= .300 FRACTIONAL= .8650

SPHERES -.02613 TANGENT .11996 LENGTH 9.656 ENERGY 490.53 SPACING .005 SADDLE .09419

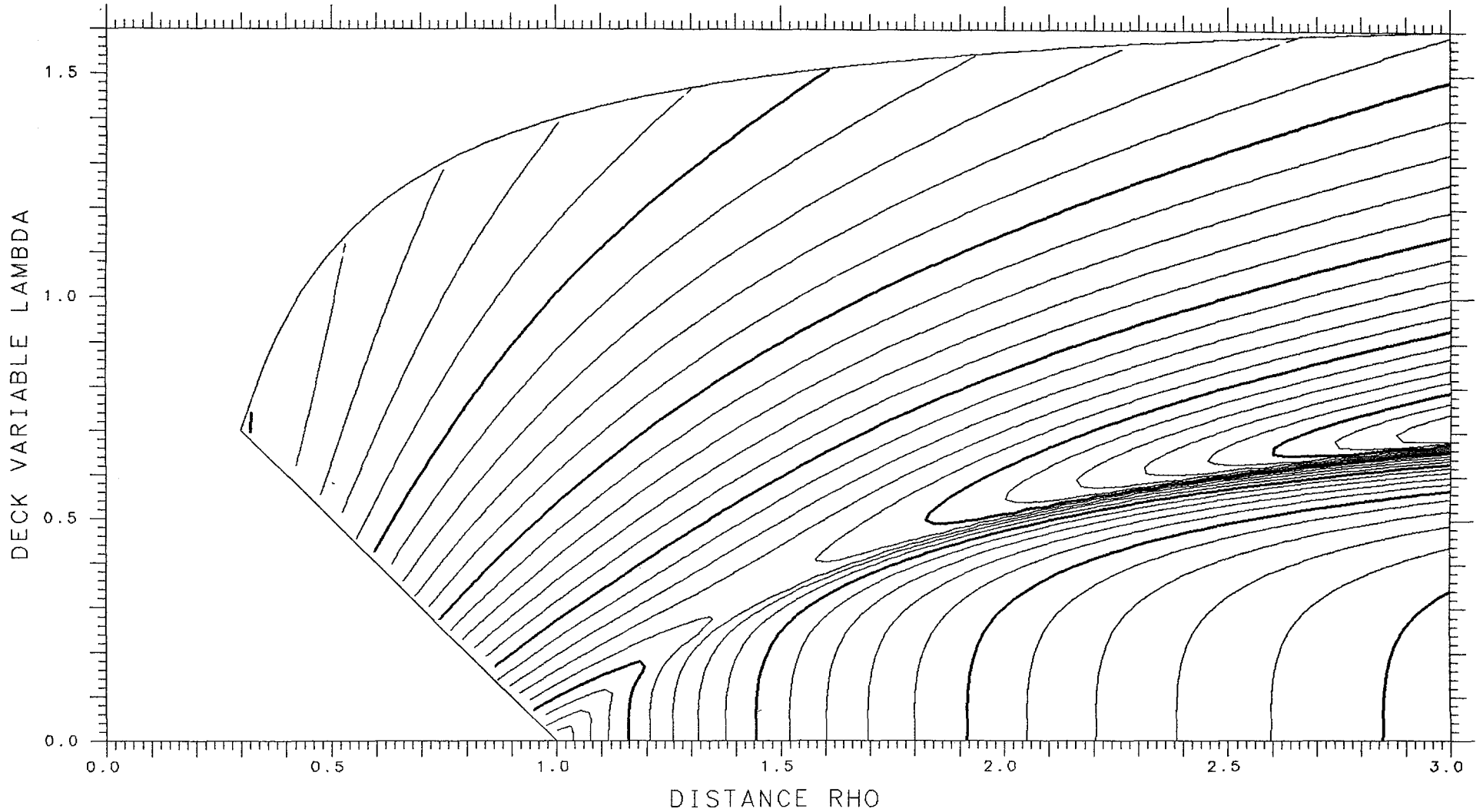

X= .900

ASYMMETRY DELTA=0.

FRACTIONAL= .5000

SPHERES -.40615

TANGENT .06632

LENGTH 12.747

ENERGY 695.85

SPACING .002

SADDLE .00083

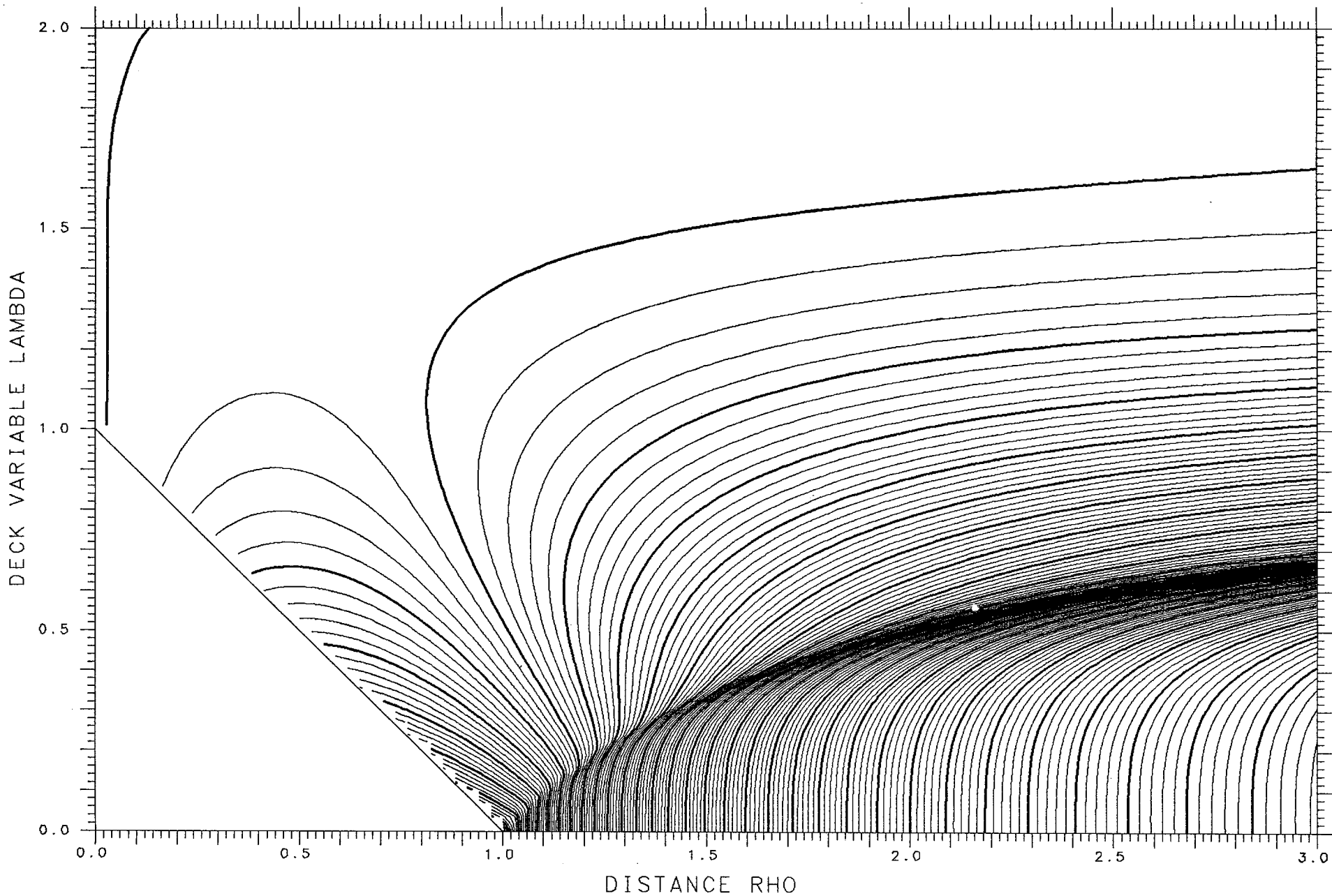

X= .550 ASYMMETRY DELTA= .325 FRACTIONAL= .8832

SPHERES -.01549 TANGENT .11507 LENGTH 9.540 ENERGY 490.53 SPACING .005 SADDLE .09316

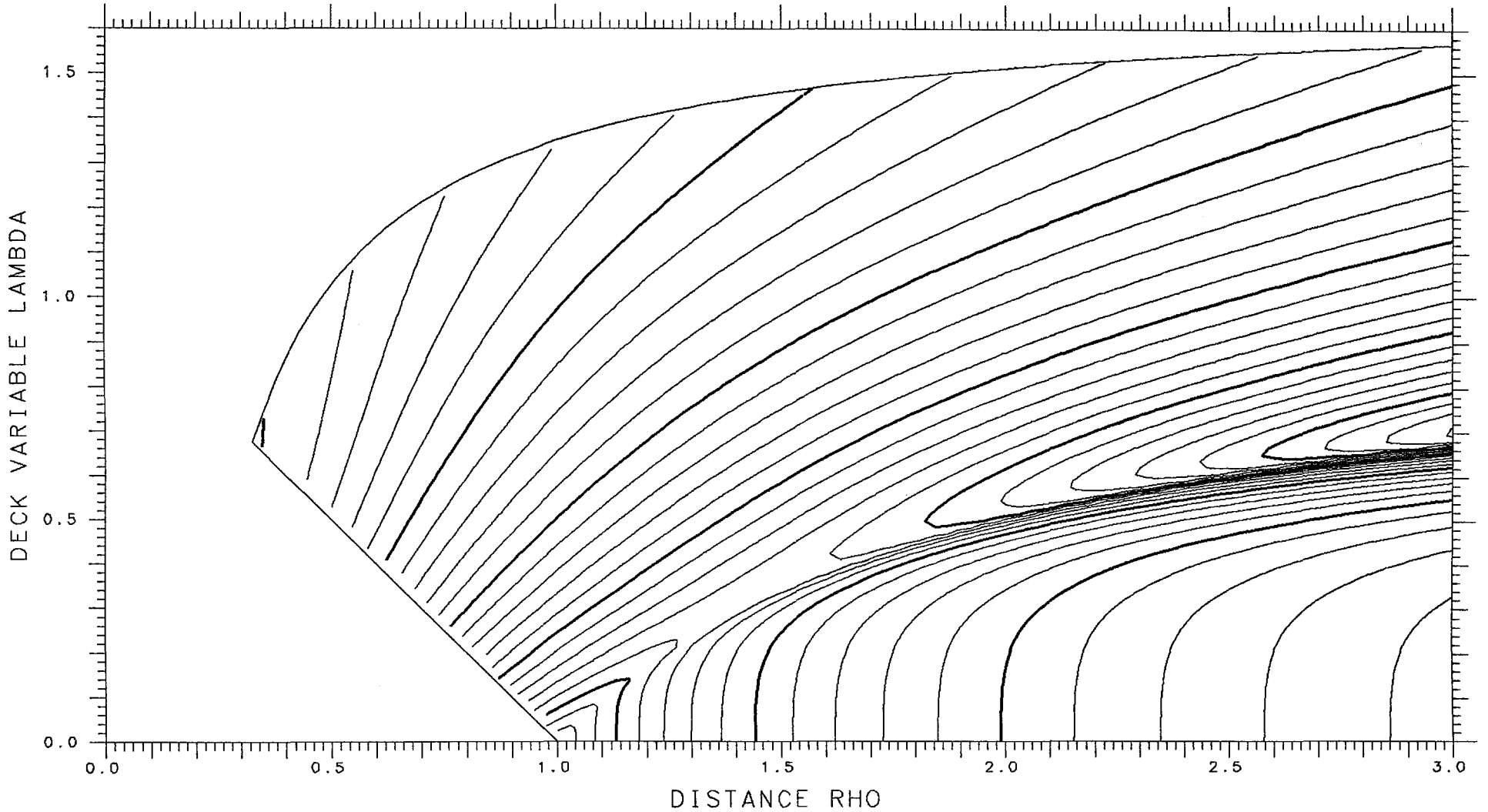

X= .875 ASYMMETRY DELTA= .600 FRACTIONAL= .9846

SPHERES .00860 TANGENT .04413 LENGTH 9.874 ENERGY 682.43 SPACING .002

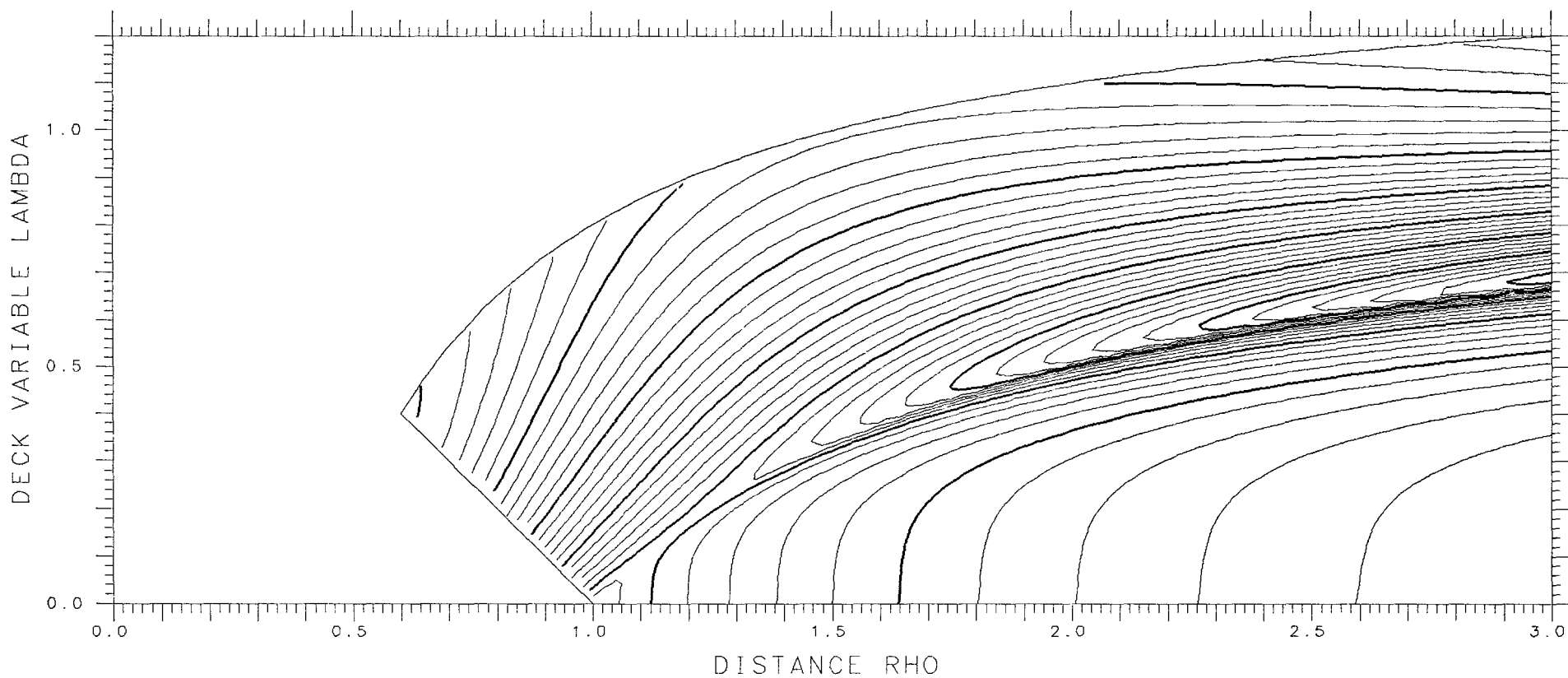

X= .550 ASYMMETRY DELTA= .350 FRACTIONAL= .8996

SPHERES -.00607 TANGENT .10972 LENGTH 9.420 ENERGY 490.53 SPACING .005 SADDLE .09135

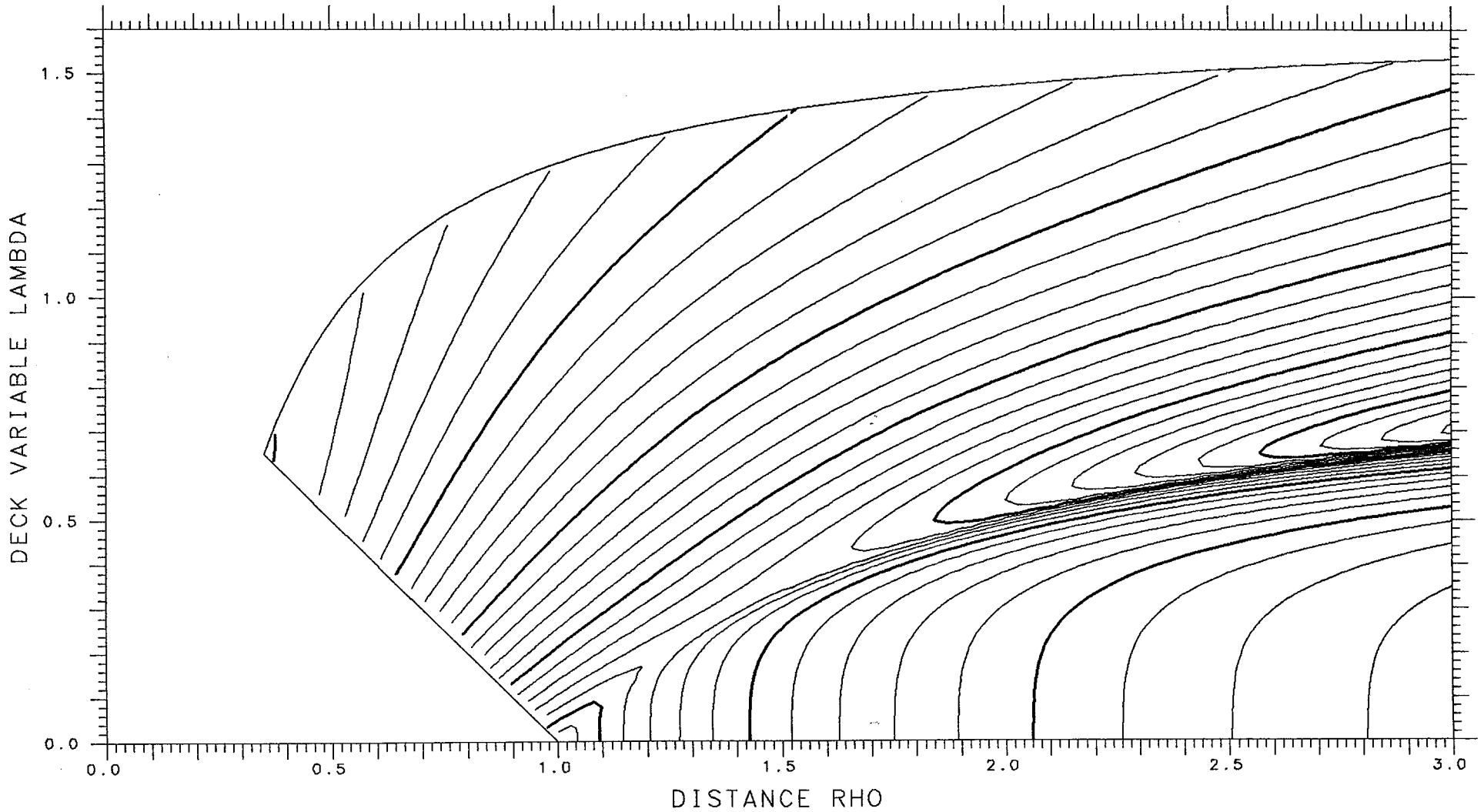

X= .875 ASYMMETRY DELTA= .575 FRACTIONAL= .9807

SPHERES .00557 TANGENT .04926 LENGTH 10.018 ENERGY 682.43 SPACING .002

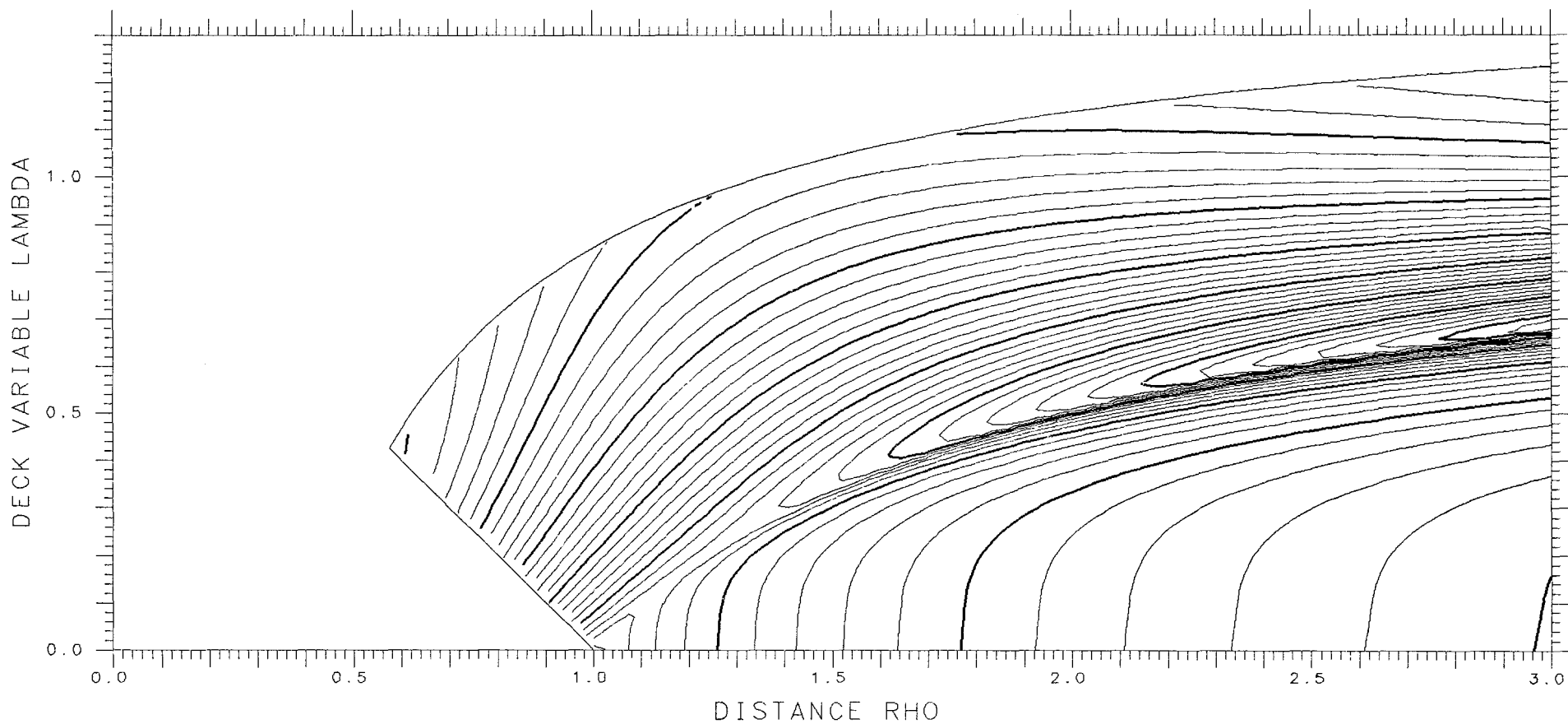

X= .550 ASYMMETRY DELTA= .375 FRACTIONAL= .9141

SPHERES .00206 TANGENT .10398 LENGTH 9.299 ENERGY 490.53 SPACING .005 SADDLE .08879

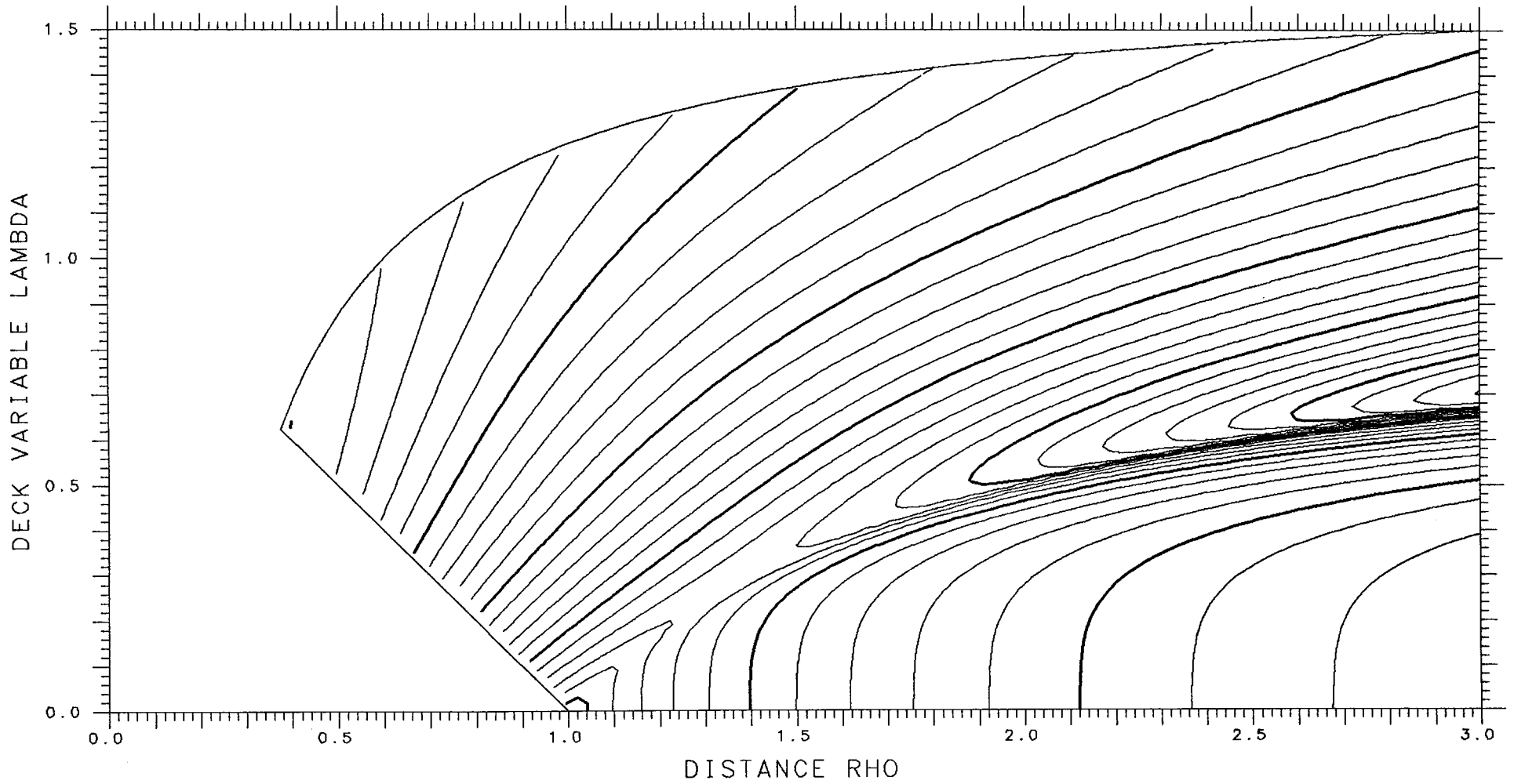

X= .875 ASYMMETRY DELTA= .550 FRACTIONAL= .9761

SPHERES .00131 TANGENT .05444 LENGTH 10.163 ENERGY 682.43 SPACING .002

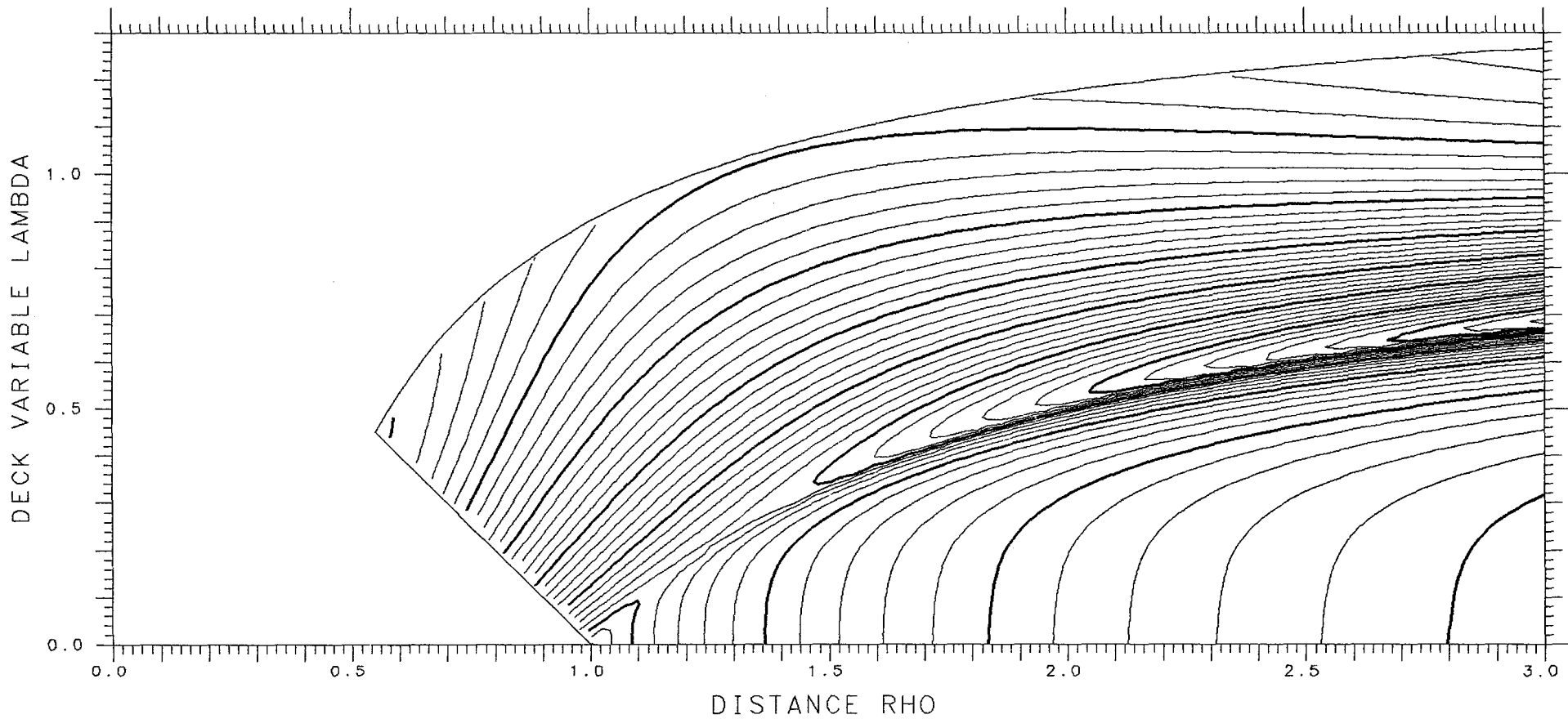

X= .550 ASYMMETRY DELTA= .400 FRACTIONAL= .9270

SPHERES .00888 TANGENT .09792 LENGTH 9.175 ENERGY 490.53 SPACING .005

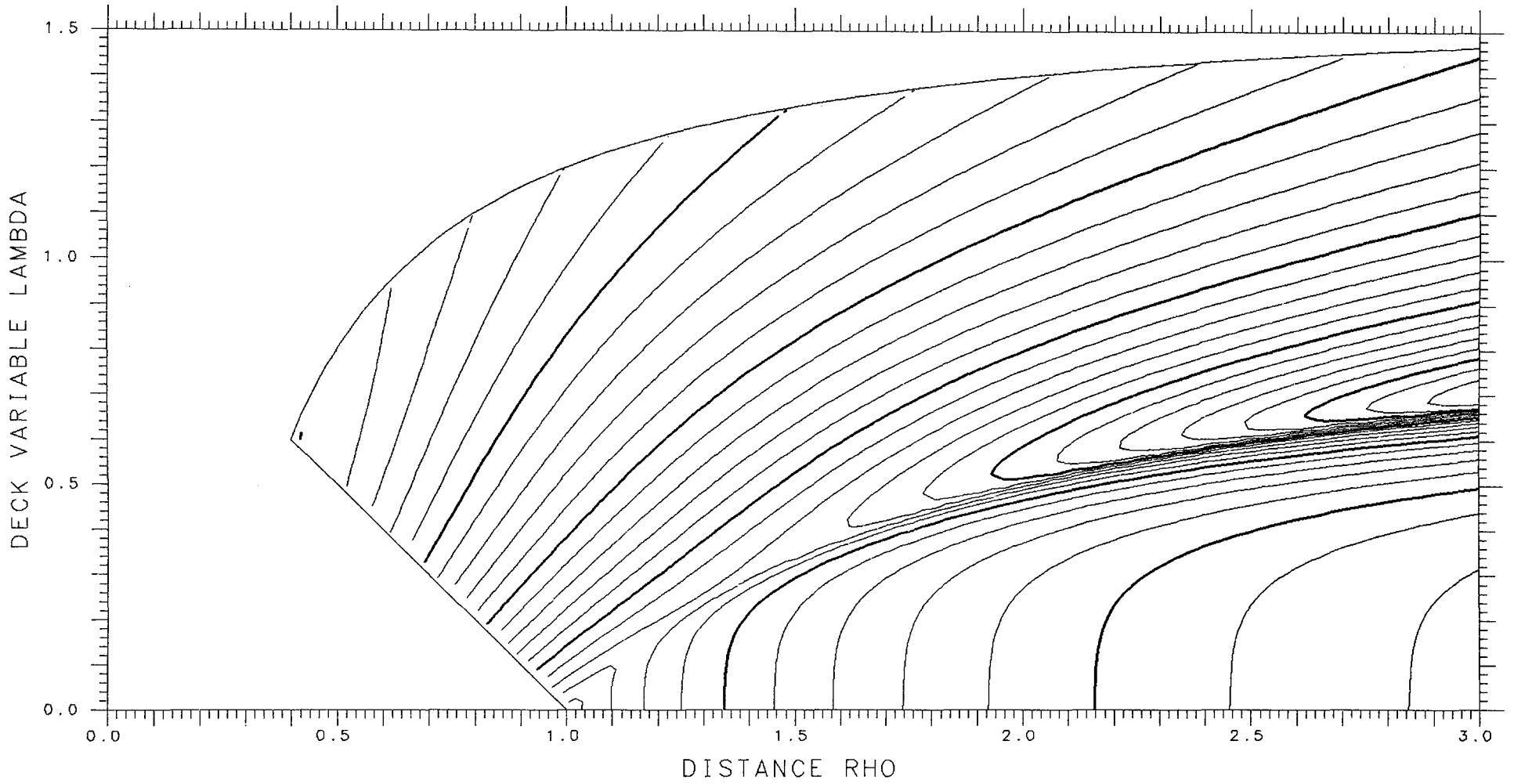

X= .875 ASYMMETRY DELTA= .525 FRACTIONAL= .9707

SPHERES -.00437 TANGENT .05958 LENGTH 10.311 ENERGY 682.43 SPACING .002

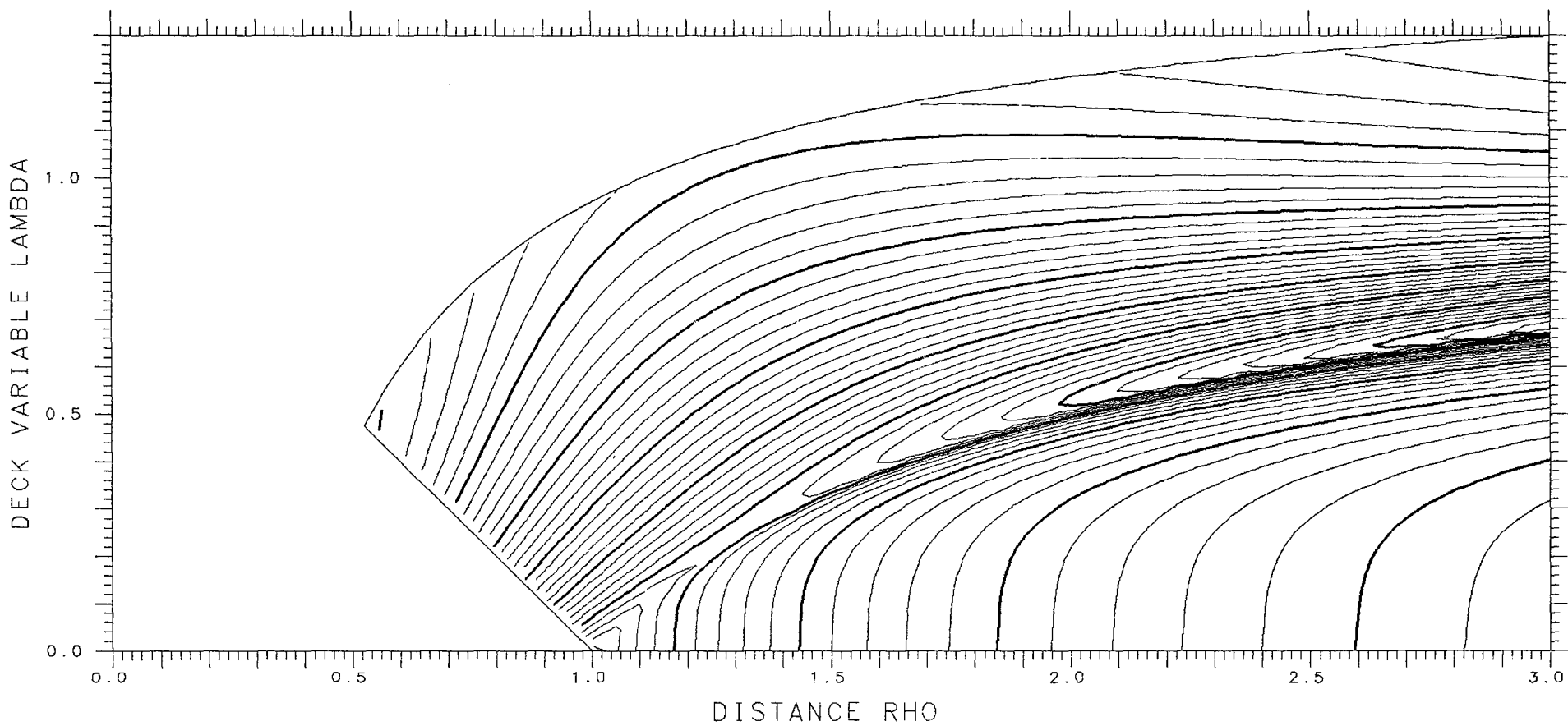

X= .550 ASYMMETRY DELTA= .425 FRACTIONAL= .9384

SPHERES .01442 TANGENT .09161 LENGTH 9.051 ENERGY 490.53 SPACING .005

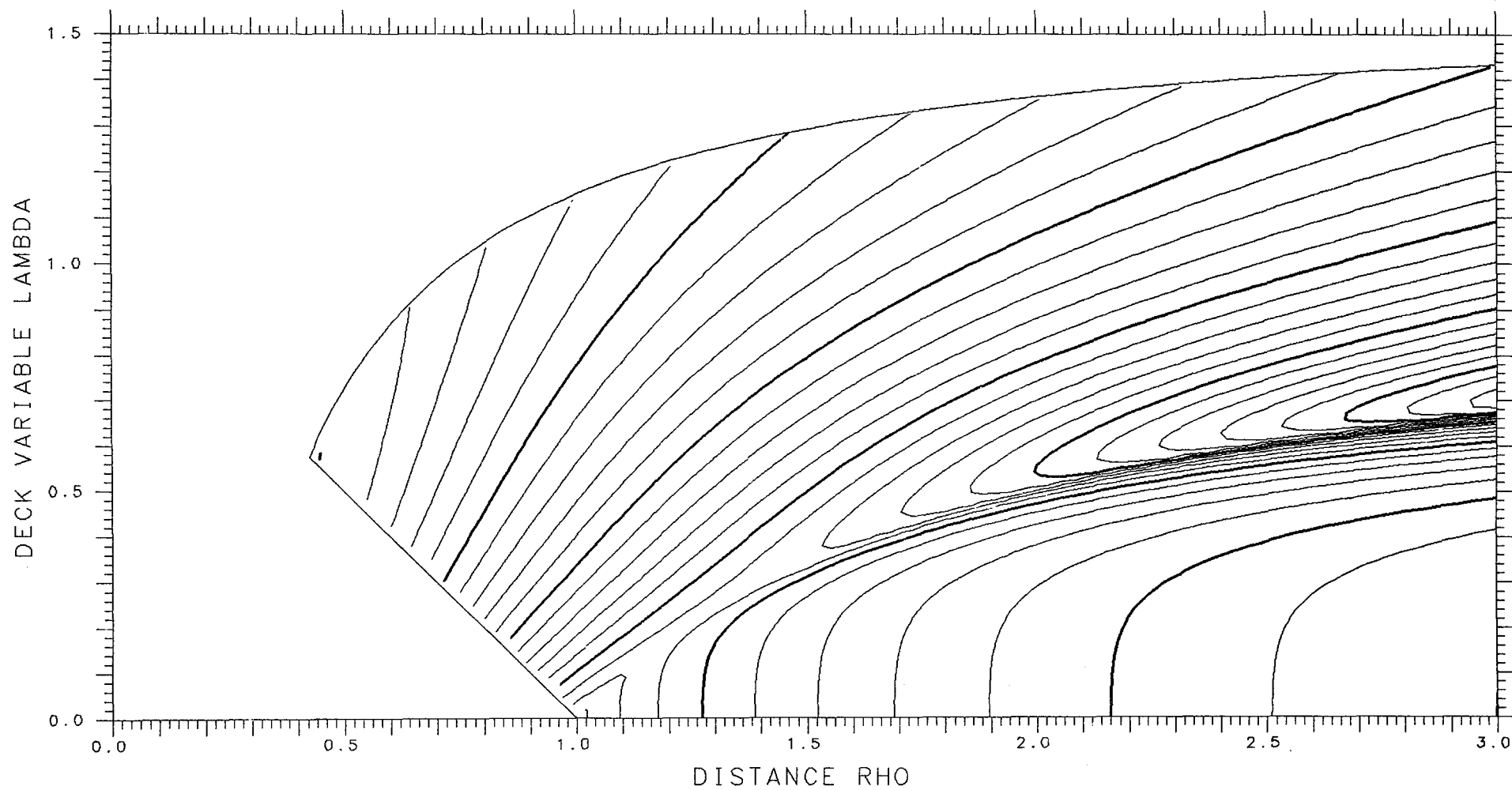

X= .875 ASYMMETRY DELTA= .500 FRACTIONAL= .9643

SPHERES -.01165 TANGENT .06461 LENGTH 10.459 ENERGY 682.43 SPACING .002

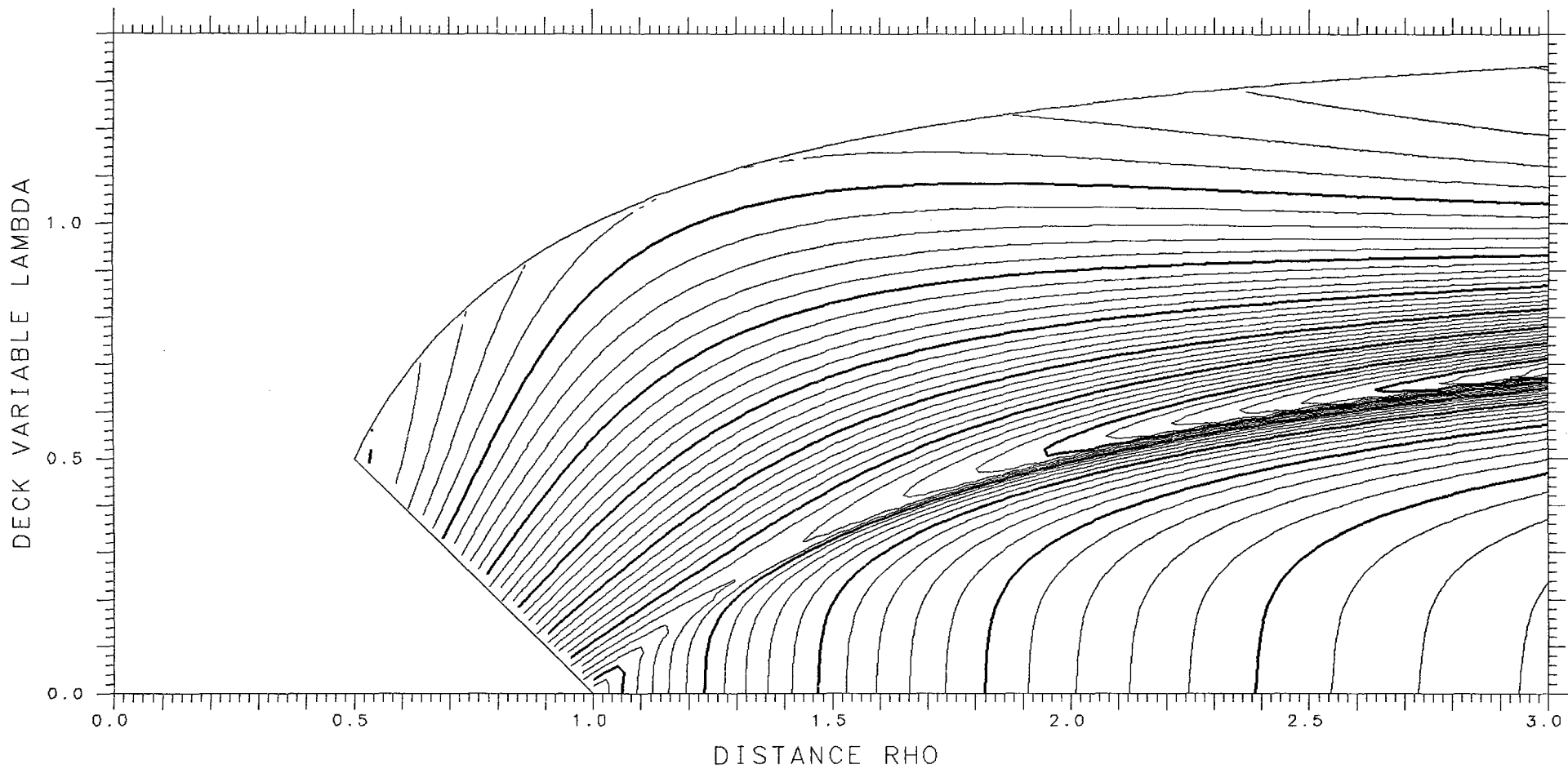

X= .550 ASYMMETRY DELTA= .450 FRACTIONAL= .9483

SPHERES .01874 TANGENT .08513 LENGTH 8.926 ENERGY 490.53 SPACING .005

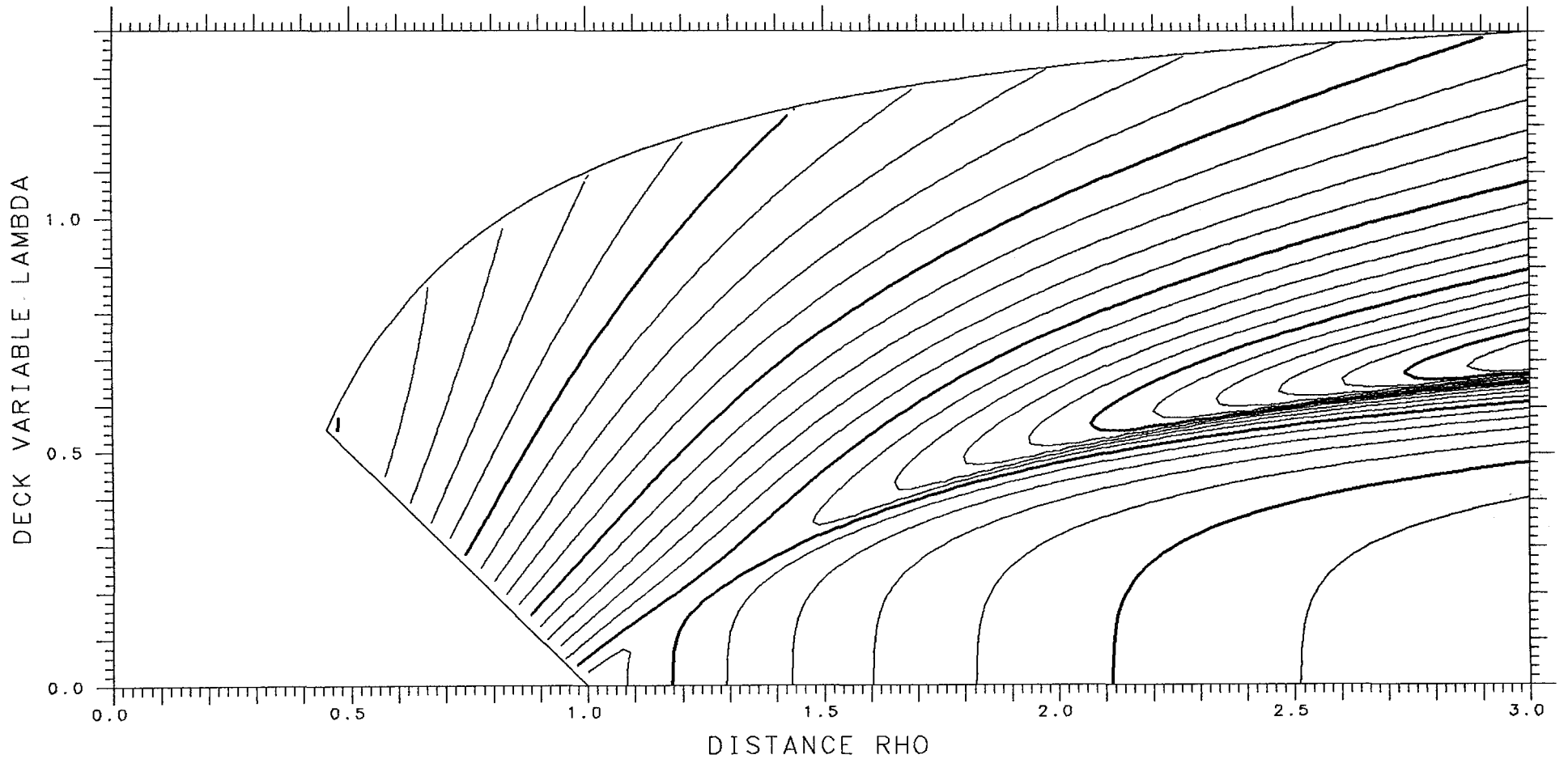

X= .875 ASYMMETRY DELTA= .475 FRACTIONAL= .9569

SPHERES -.02070 TANGENT .06943 LENGTH 10.609 ENERGY 682.43 SPACING .002 SADDLE .05535

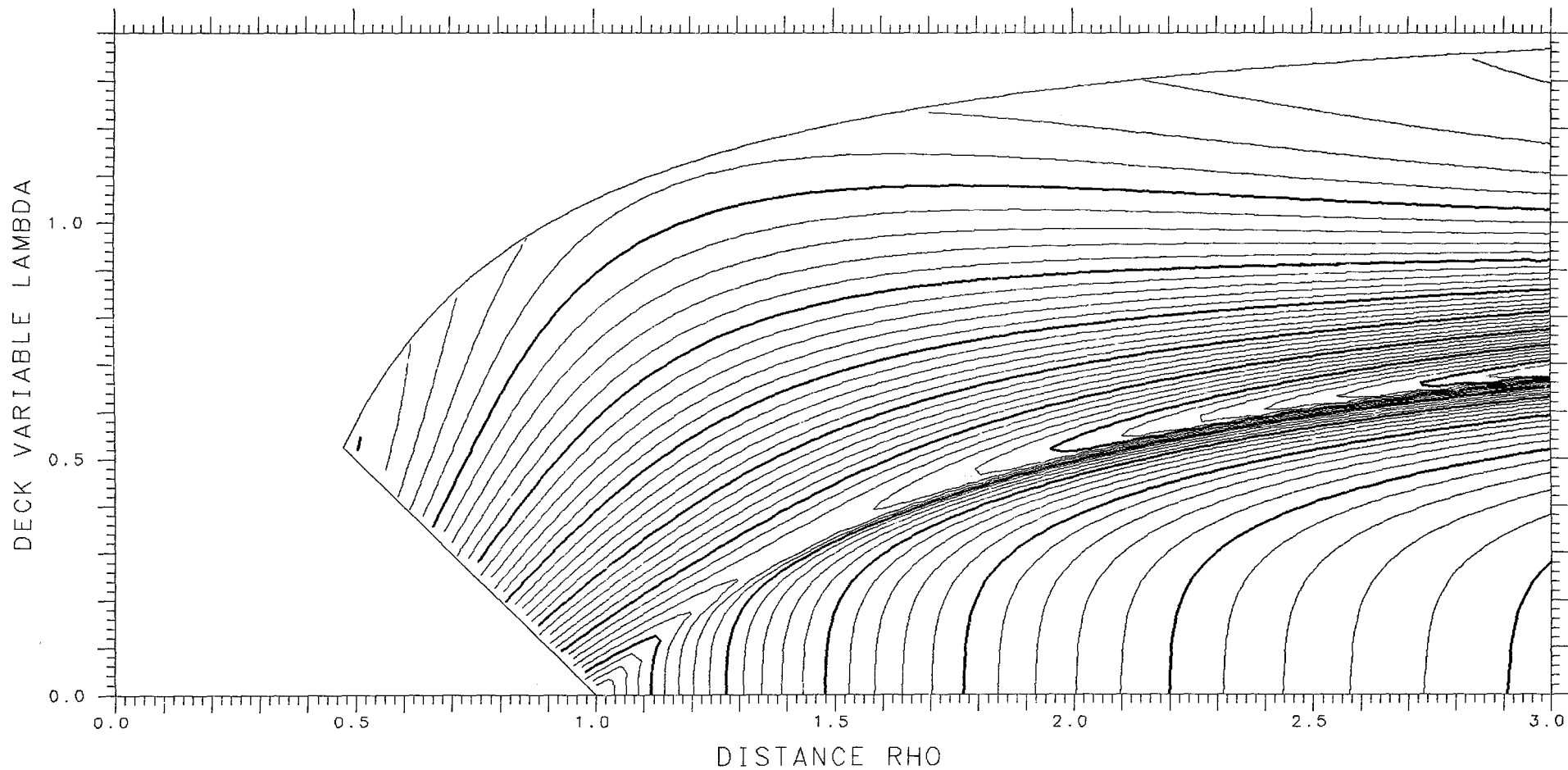

X= .550 ASYMMETRY DELTA= .475 FRACTIONAL= .9569

SPHERES .02192 TANGENT .07857 LENGTH 8.801 ENERGY 490.53 SPACING .005

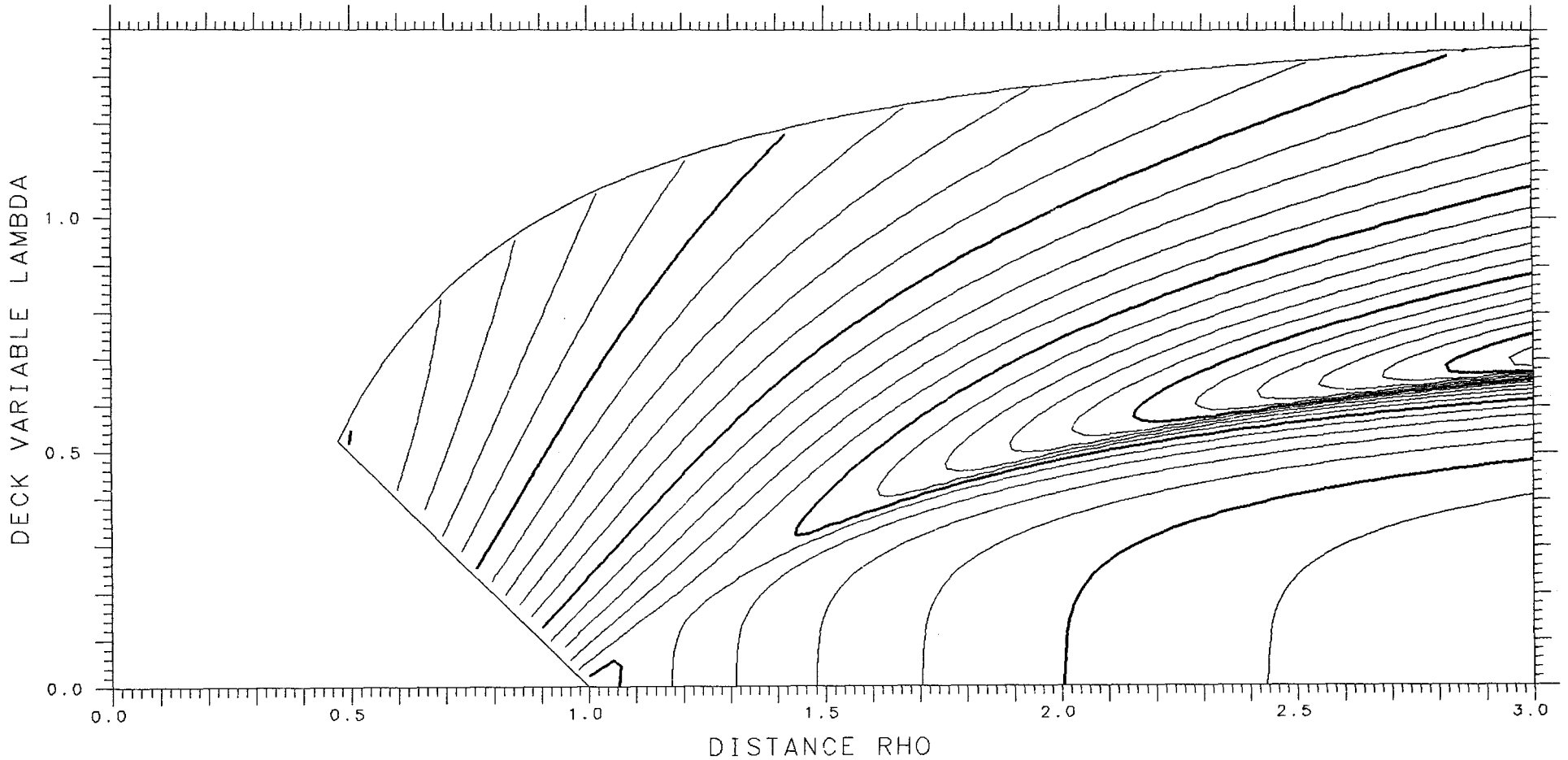

X= .875 ASYMMETRY DELTA= .450 FRACTIONAL= .9483

SPHERES -.03168 TANGENT .07394 LENGTH 10.760 ENERGY 682.43 SPACING .002 SADDLE .05584

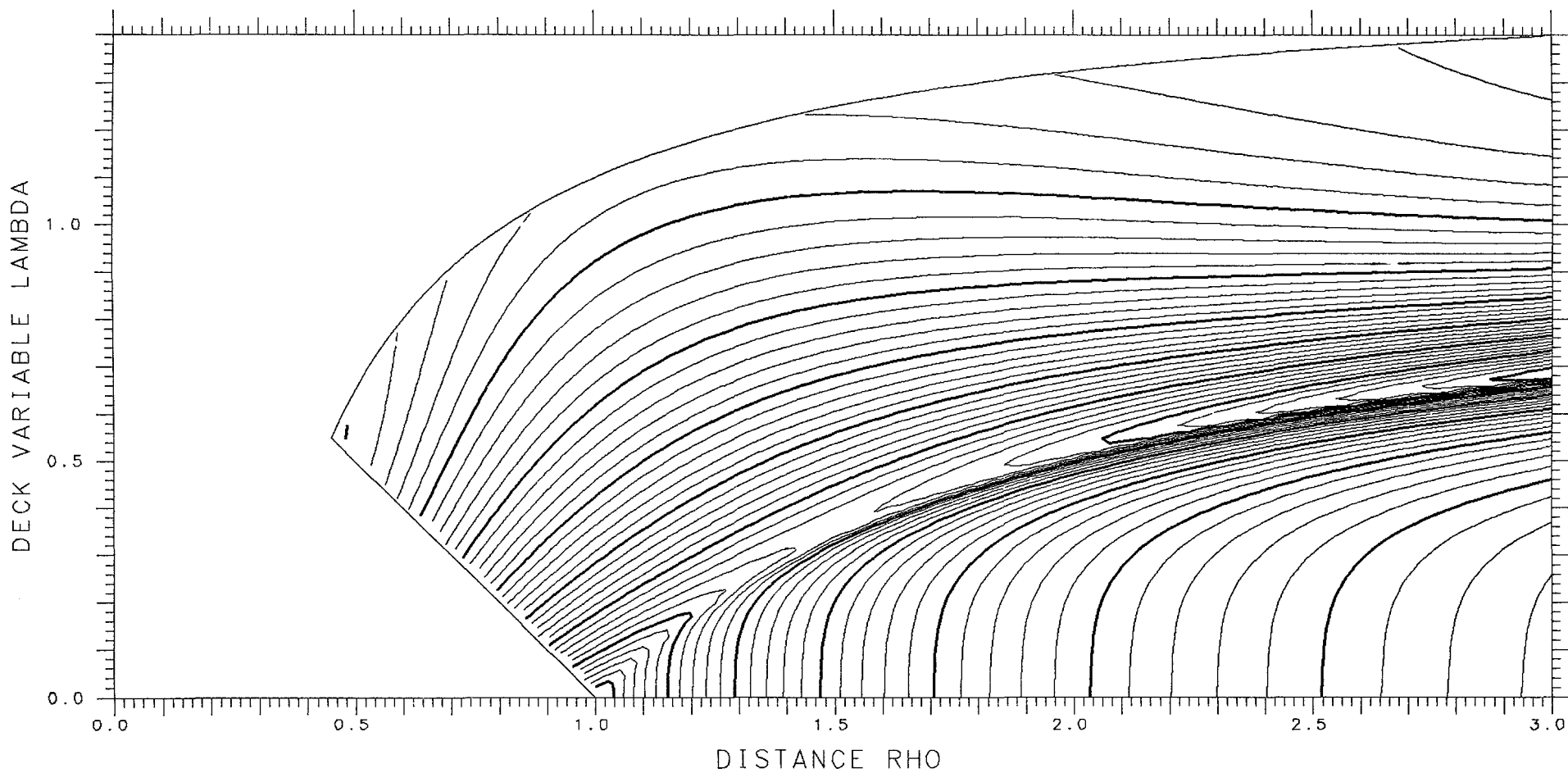

X= .550 ASYMMETRY DELTA= .500 FRACTIONAL= .9643

SPHERES .02406 TANGENT .07199 LENGTH 8.677 ENERGY 490.53 SPACING .005

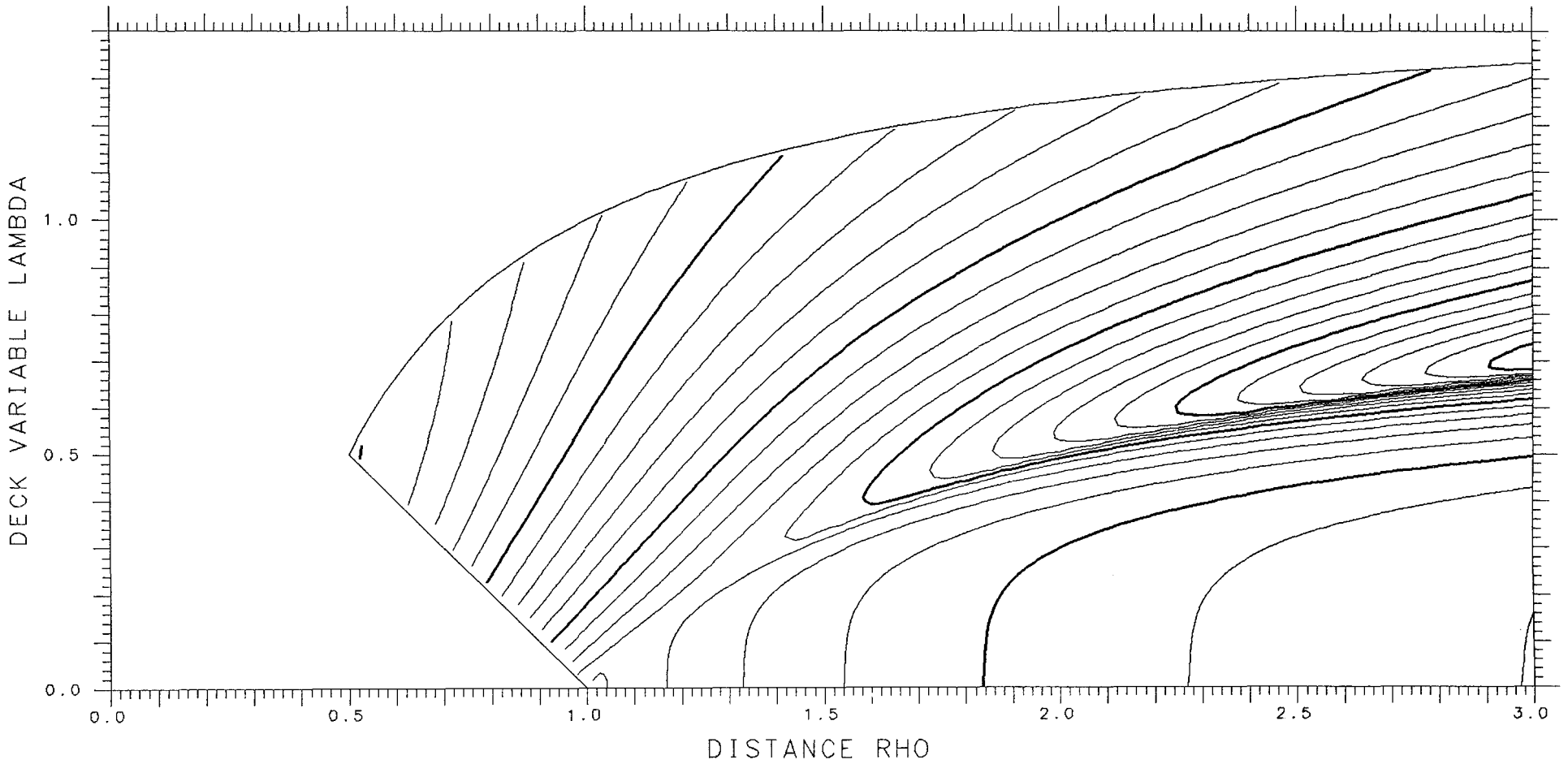

X= .875 ASYMMETRY DELTA= .425 FRACTIONAL= .9384

SPHERES -.04473 TANGENT .07806 LENGTH 10.910 ENERGY 682.43 SPACING .002 SADDLE .05510

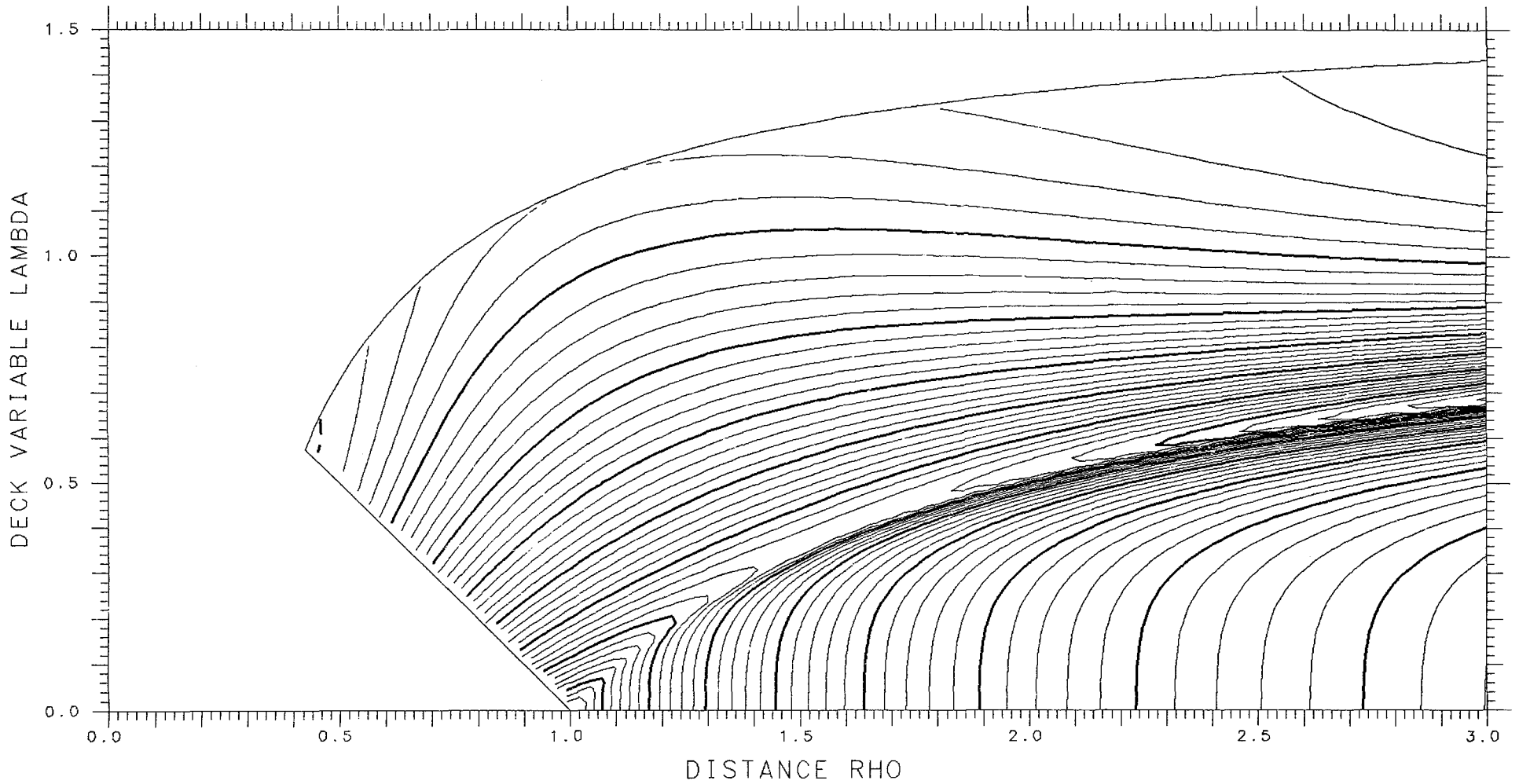

X= .550 ASYMMETRY DELTA= .525 FRACTIONAL= .9707

SPHERES .02528 TANGENT .06546 LENGTH 8.553 ENERGY 490.53 SPACING .005

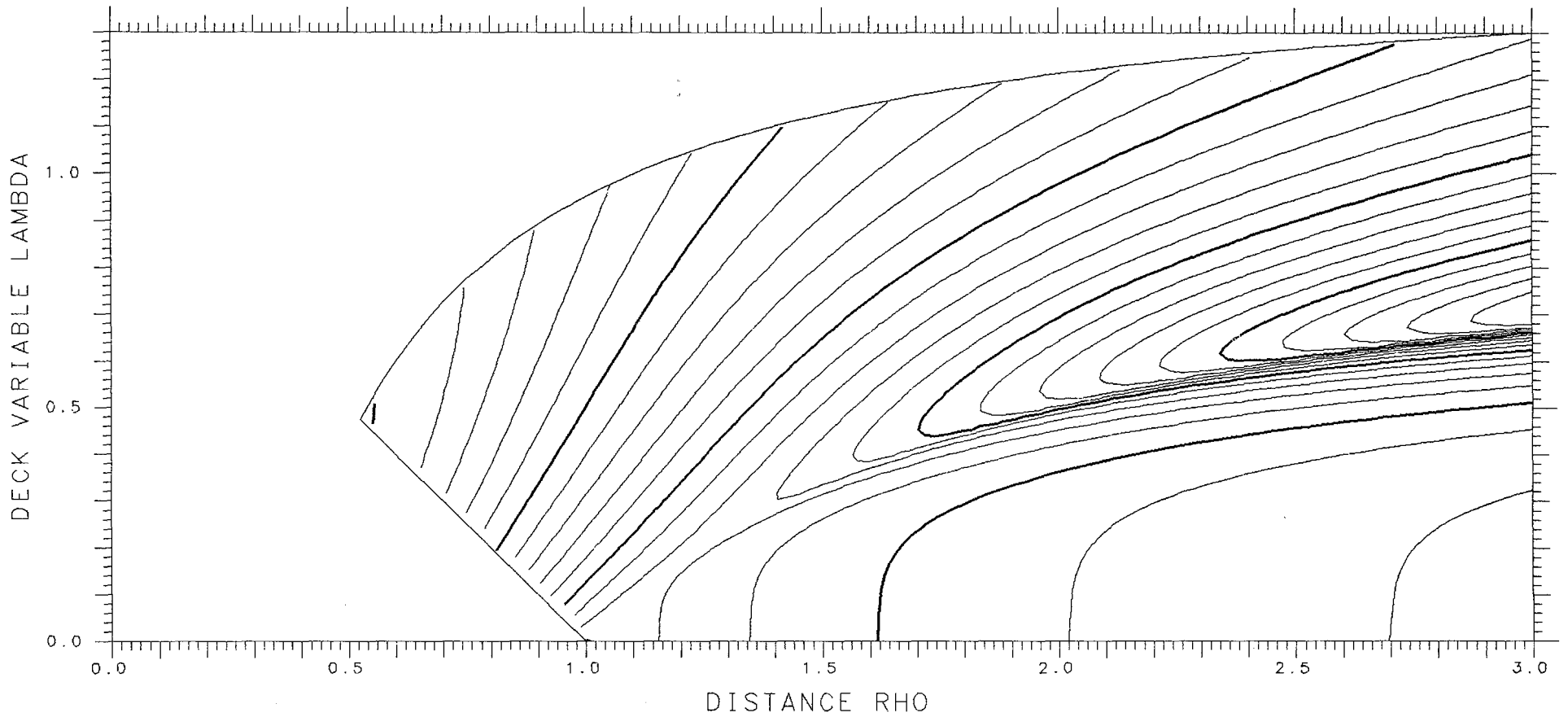

X= .875 ASYMMETRY DELTA= .400 FRACTIONAL= .9270

SPHERES -.05995 TANGENT .08170 LENGTH 11.060 ENERGY 682.43 SPACING .002 SADDLE .05295

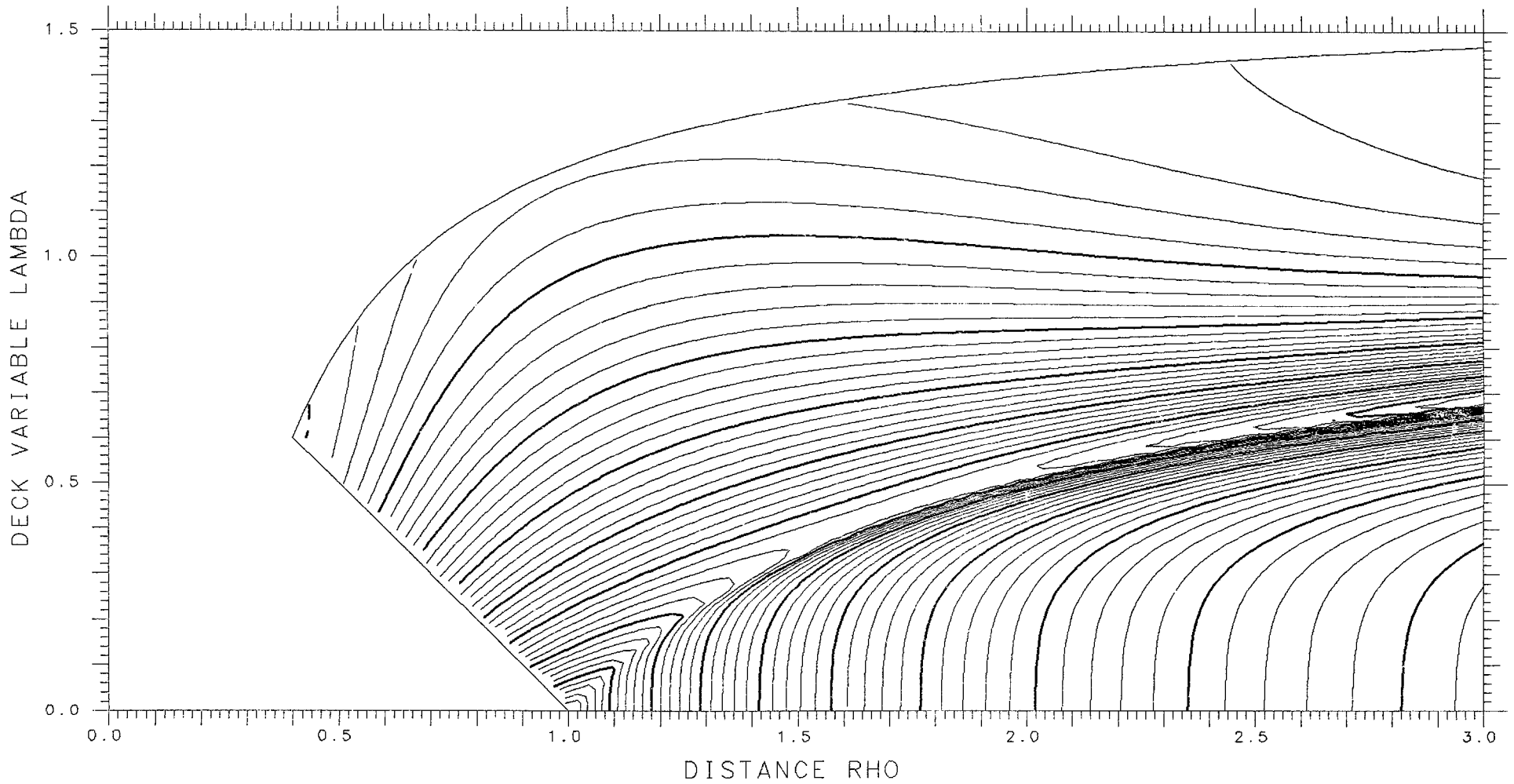

X= .600

ASYMMETRY DELTA=0.

FRACTIONAL= .5000

SPHERES -.18413

TANGENT .13085

LENGTH 10.830

ENERGY 522.49

SPACING .002

SADDLE .05916

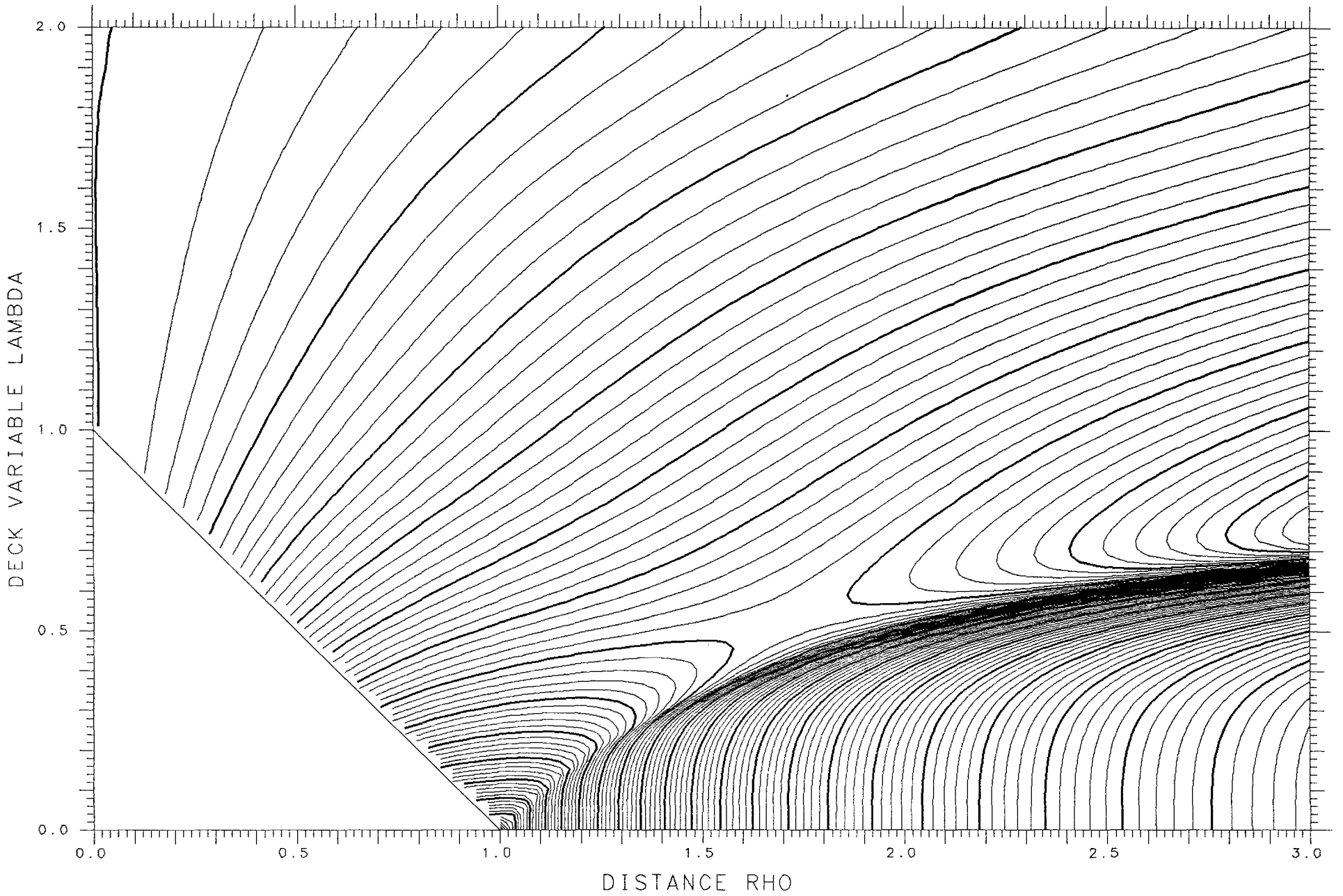

X= .875 ASYMMETRY DELTA= .375 FRACTIONAL= .9141

SPHERES -.07740 TANGENT .08475 LENGTH 11.209 ENERGY 682.43 SPACING .002 SADDLE .04923

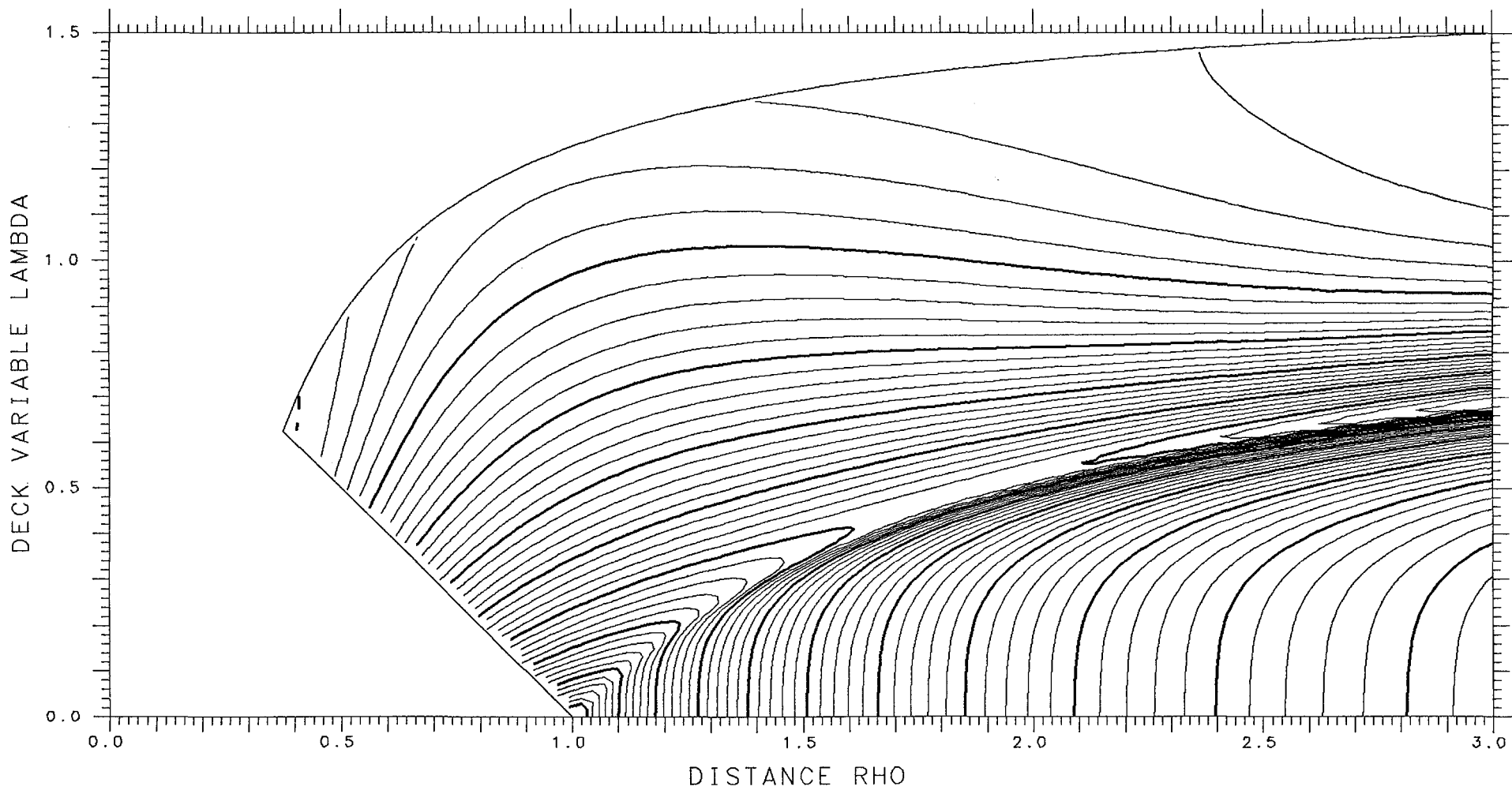

X= .600

ASYMMETRY DELTA= .025

FRACTIONAL= .5374

SPHERES -.18256

TANGENT .13085

LENGTH 10.823

ENERGY 522.49

SPACING .002

SADDLE .05953

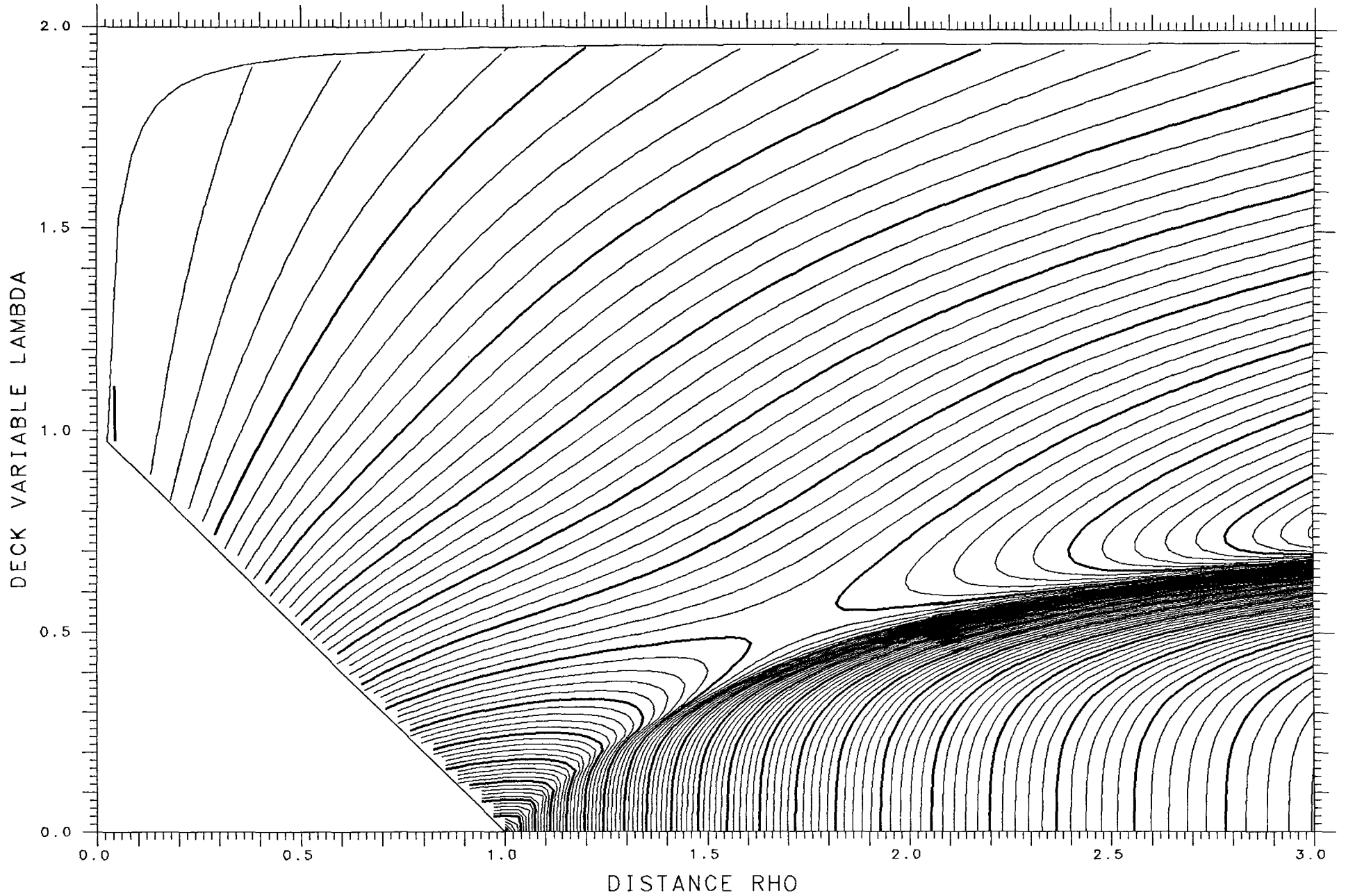

X= .875 ASYMMETRY DELTA= .350 FRACTIONAL= .8996

SPHERES - .09707 TANGENT .08715 LENGTH 11.356 ENERGY 682.43 SPACING .002 SADDLE .04390

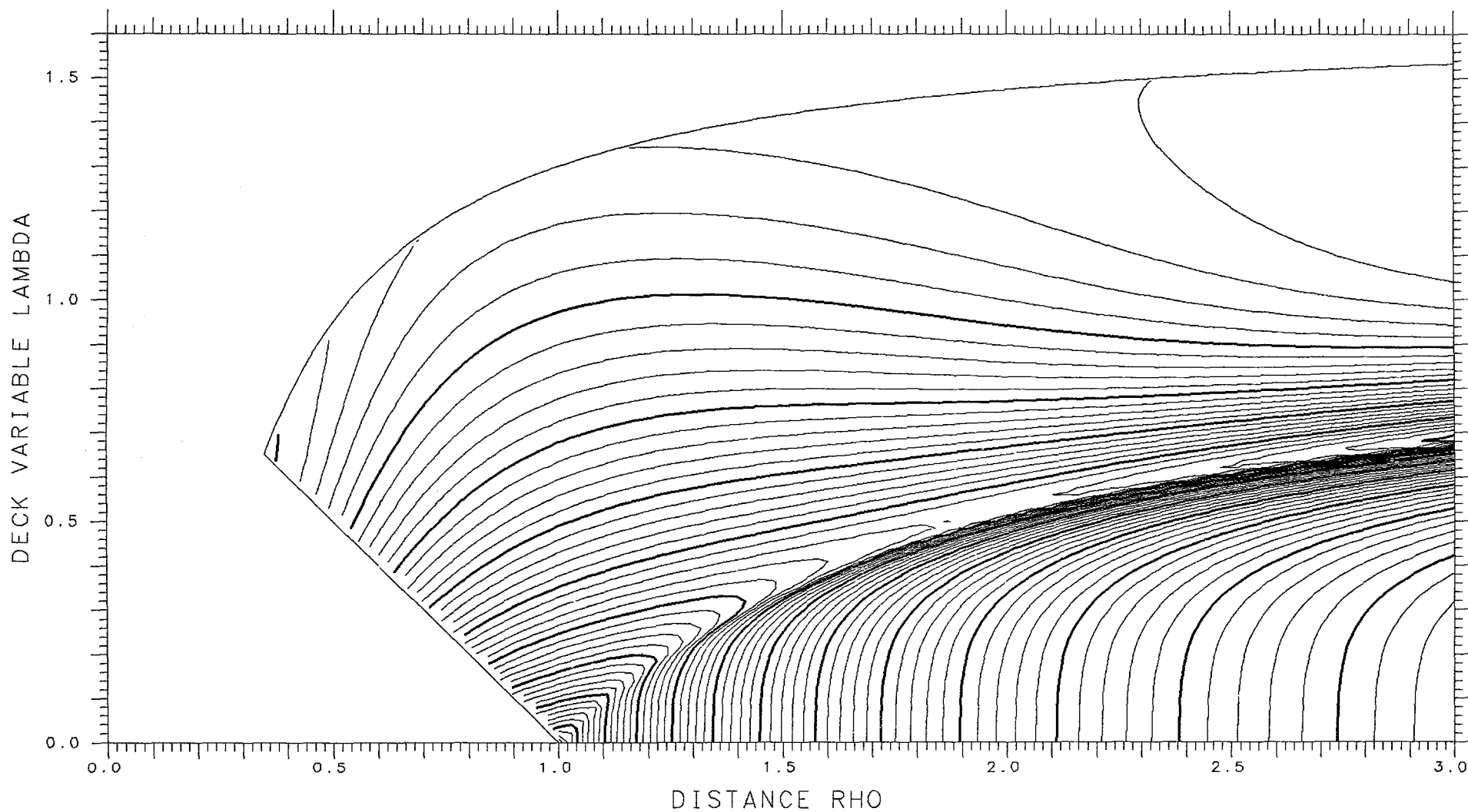

X= .600 ASYMMETRY DELTA= .050 FRACTIONAL= .5745

SPHERES -.17792 TANGENT .13083 LENGTH 10.803 ENERGY 522.49 SPACING .002 SADDLE .06062

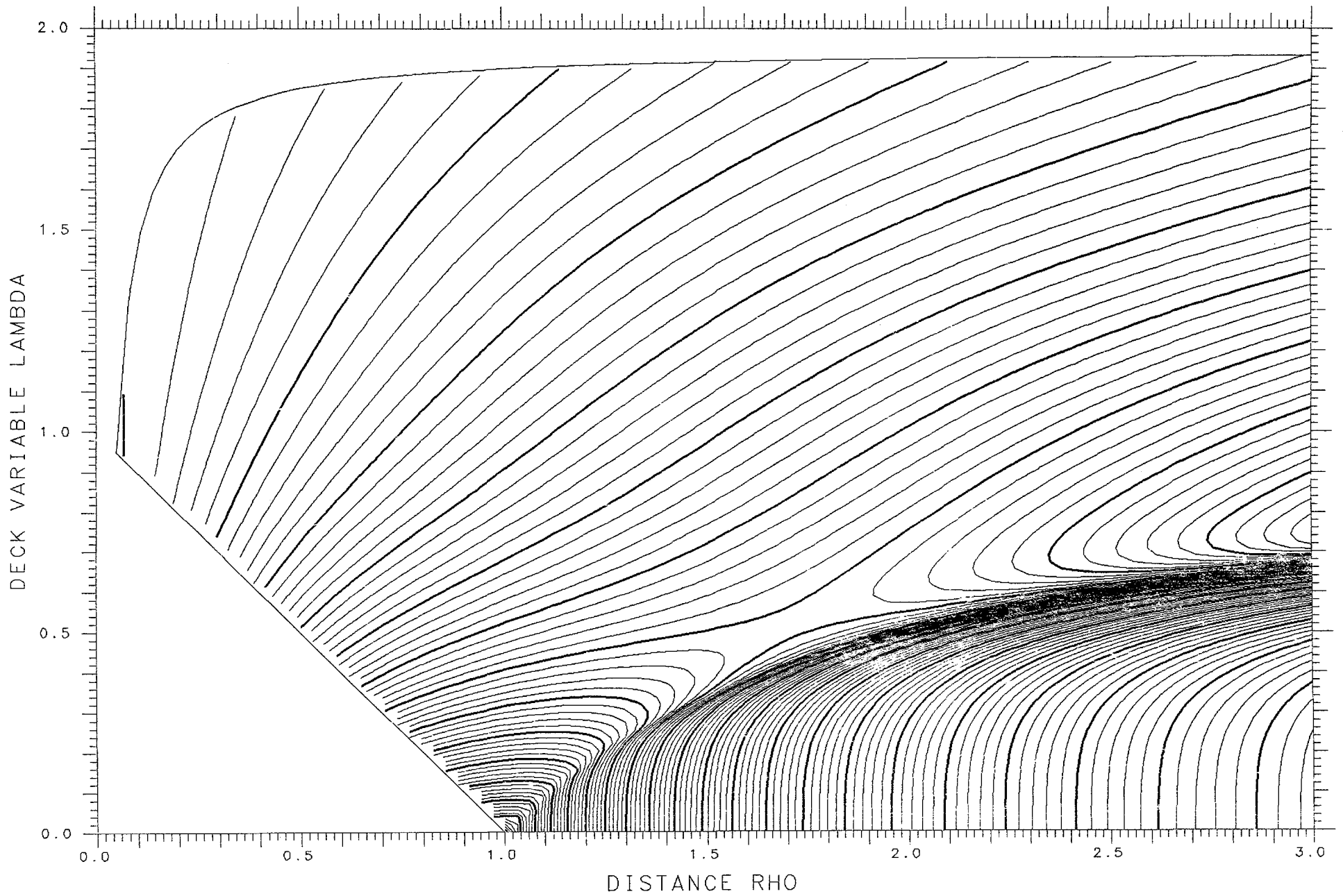

X= .875 ASYMMETRY DELTA= .325 FRACTIONAL= .8832

SPHERES -.11887 TANGENT .08884 LENGTH 11.499 ENERGY 682.43 SPACING .002 SADDLE .03699

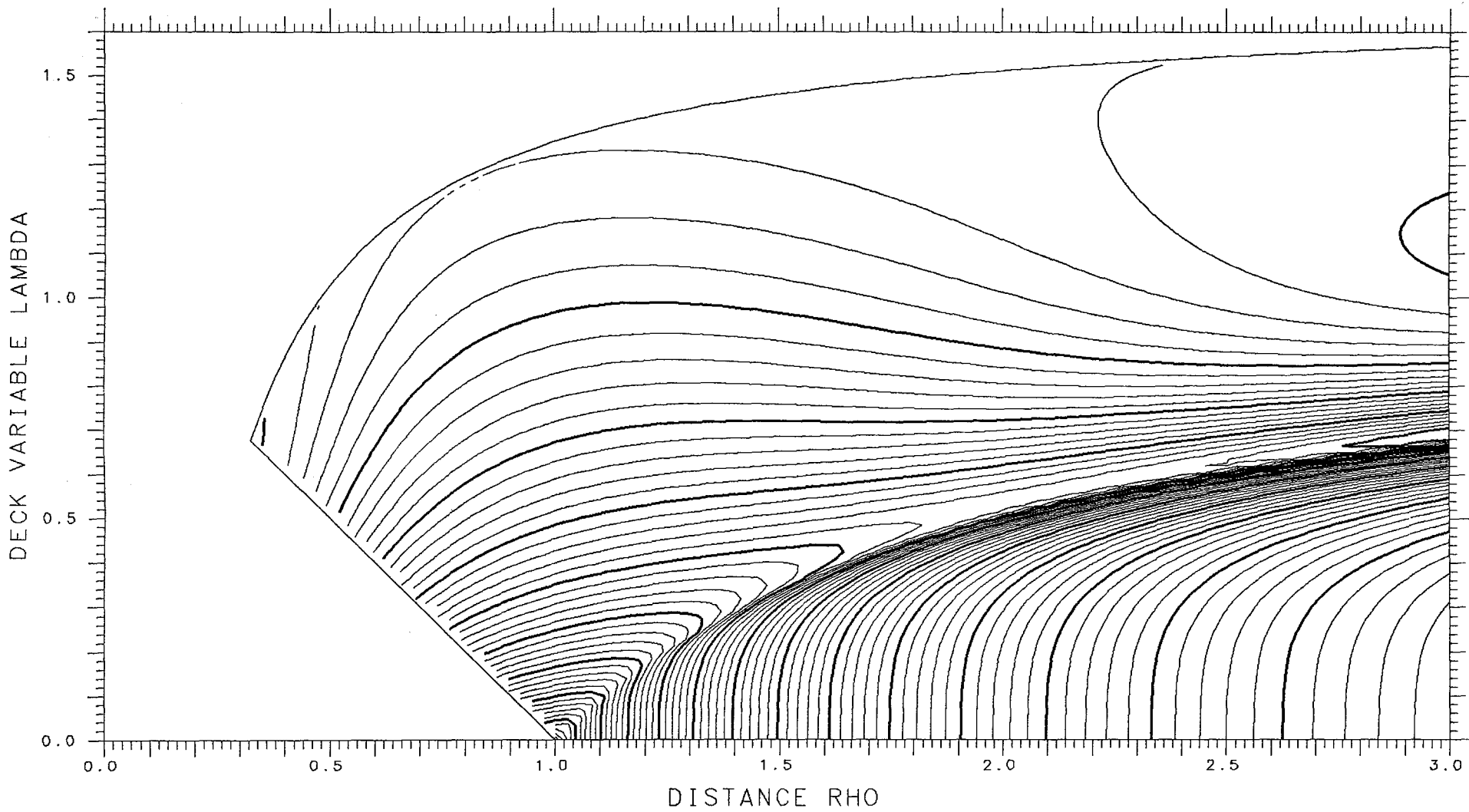

X= .600 ASYMMETRY DELTA= .075 FRACTIONAL= .6108

SPHERES -.17042 TANGENT .13076 LENGTH 10.770 ENERGY 522.49 SPACING .002 SADDLE .06239

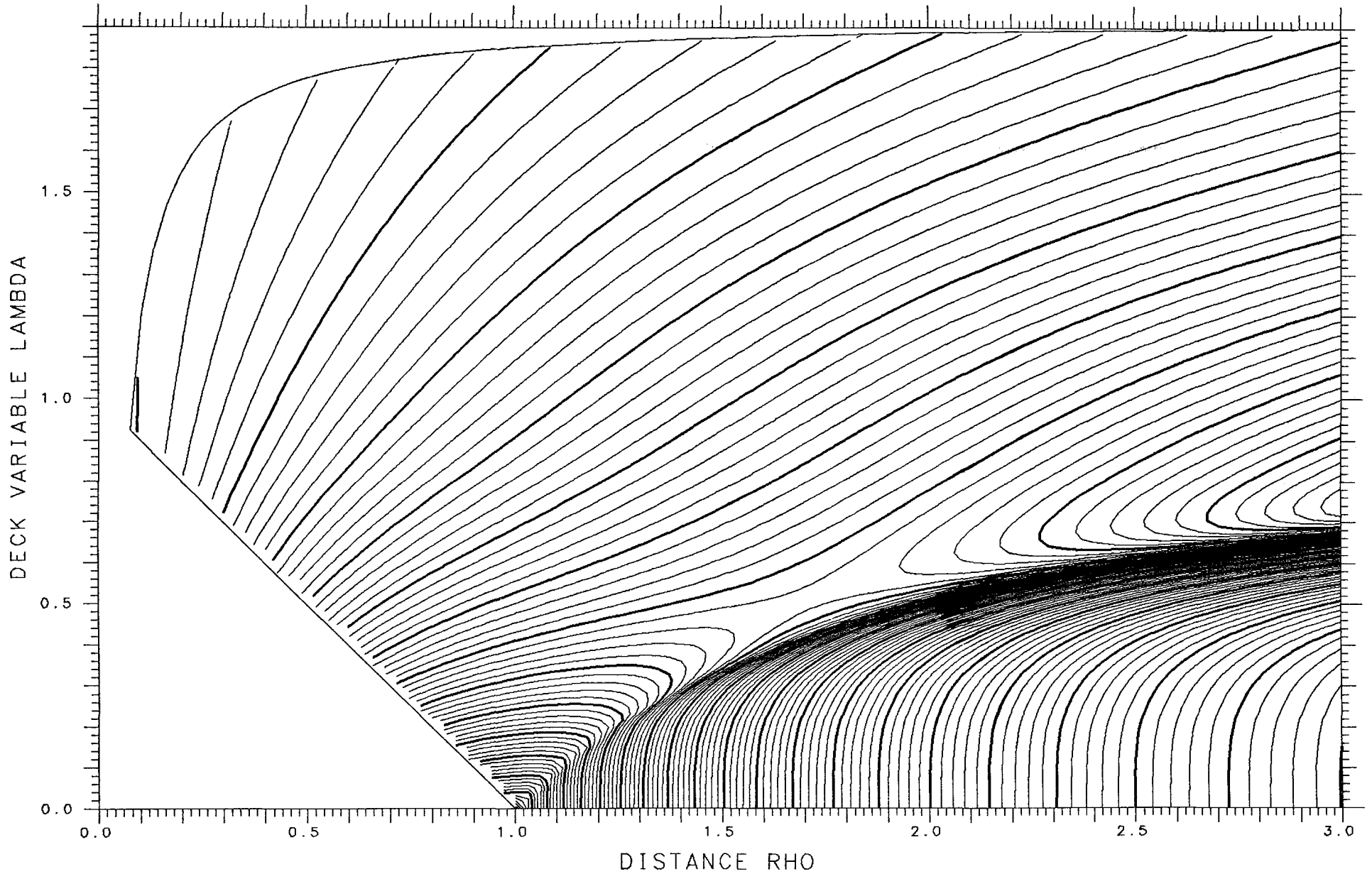

X= .875 ASYMMETRY DELTA= .300 FRACTIONAL= .8650

SPHERES -.14263 TANGENT .08979 LENGTH 11.639 ENERGY 682.43 SPACING .002 SADDLE .02863

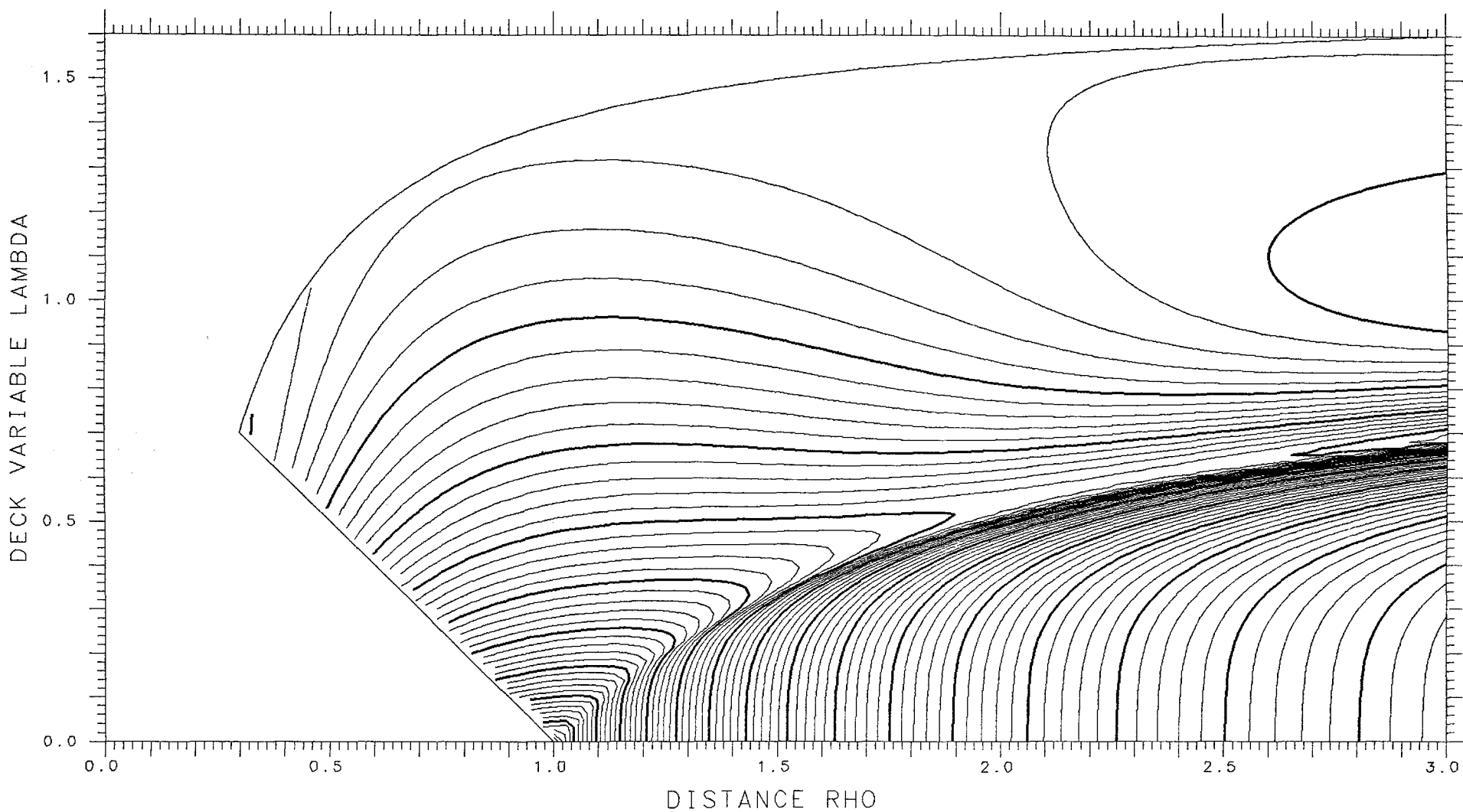

X= .600

ASYMMETRY DELTA= .100

FRACTIONAL= .6461

SPHERES -.16038

TANGENT .13056

LENGTH 10.724

ENERGY 522.49

SPACING .002

SADDLE .06476

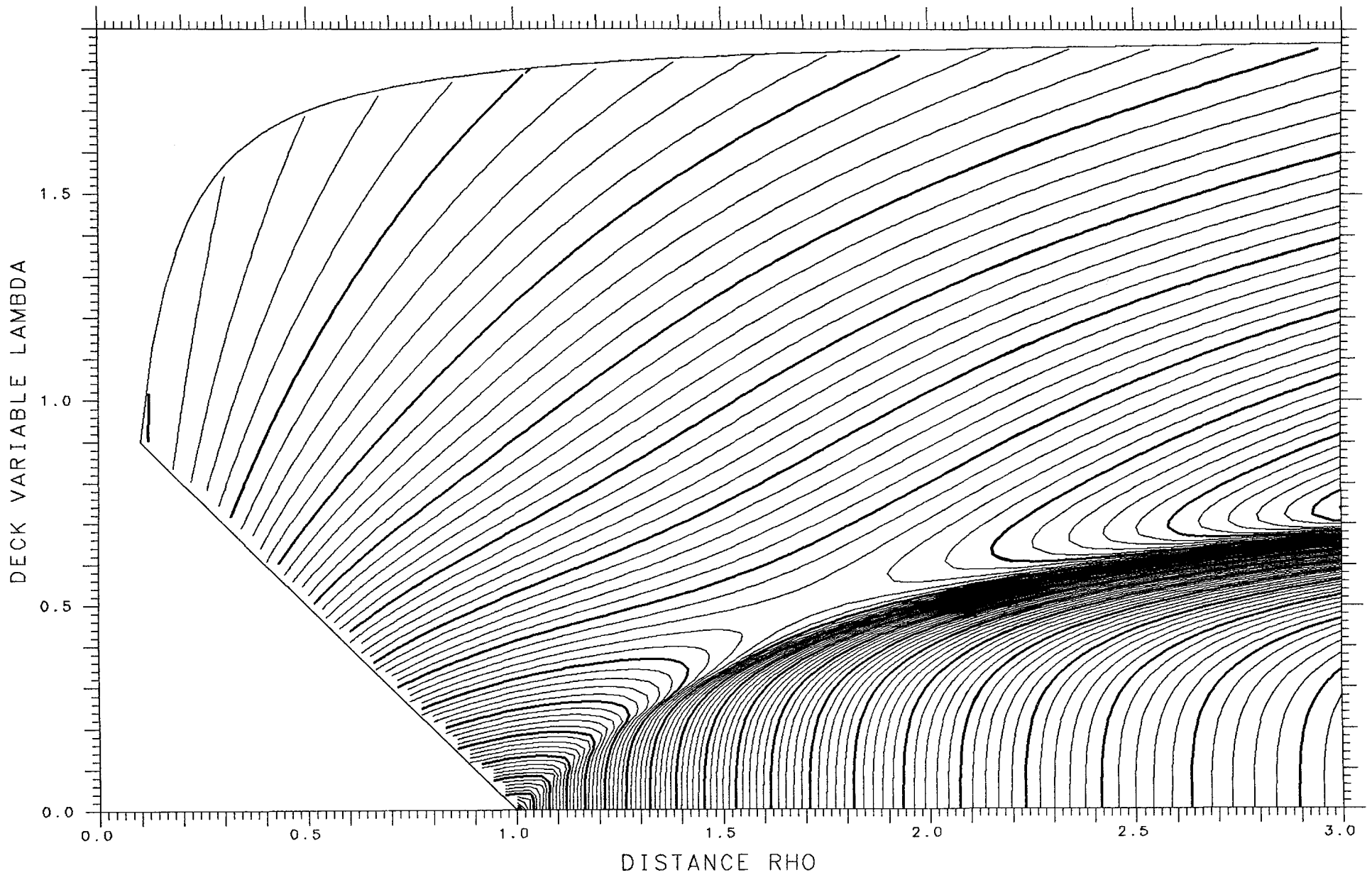

X= .875 ASYMMETRY DELTA= .275 FRACTIONAL= .8447

SPHERES -.16806 TANGENT .08998 LENGTH 11.774 ENERGY 682.43 SPACING .002 SADDLE .01905

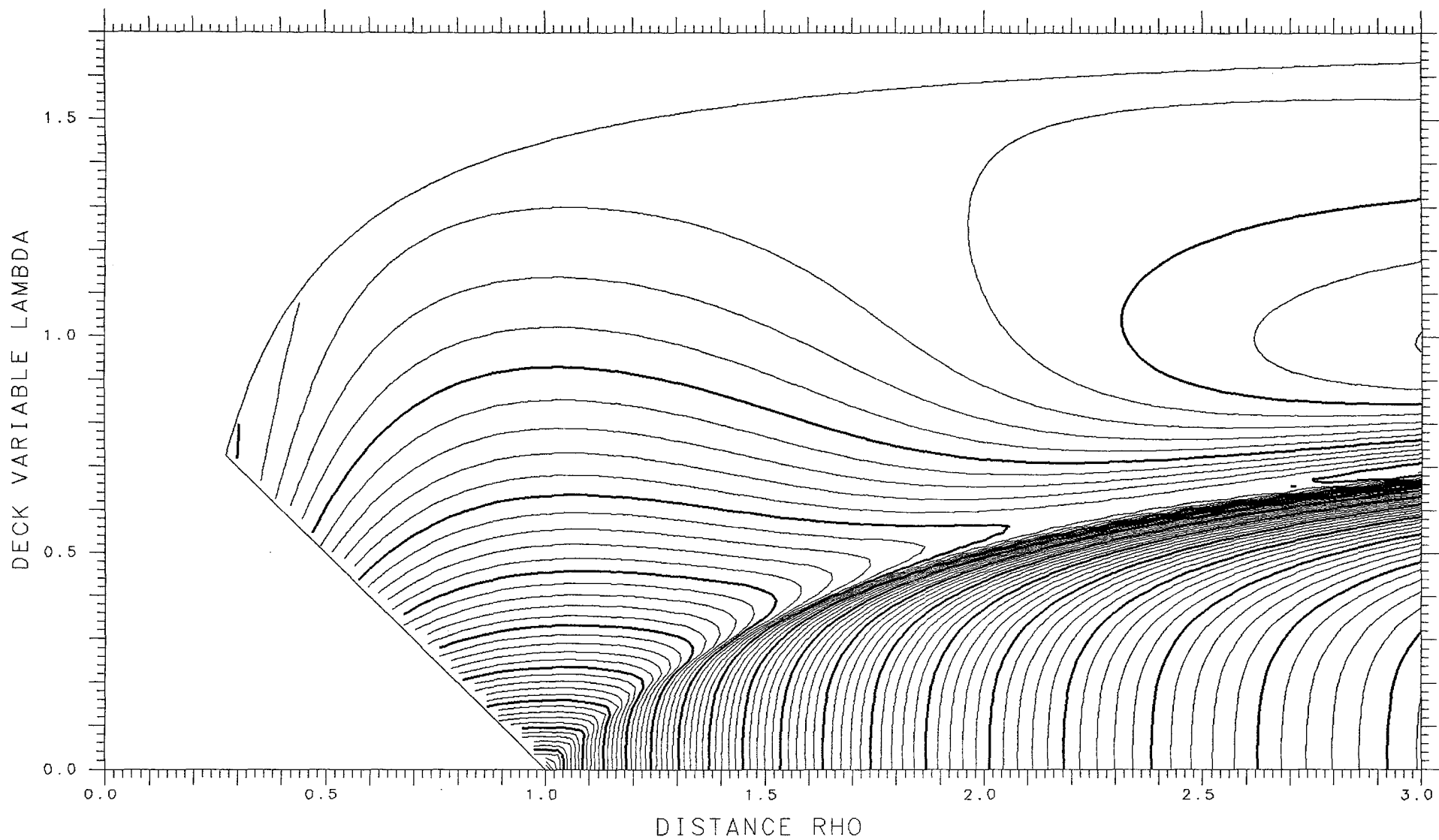

X= .600 ASYMMETRY DELTA= .125 FRACTIONAL= .6800

SPHERES -.14821 TANGENT .13015 LENGTH 10.666 ENERGY 522.49 SPACING .002 SADDLE .06763

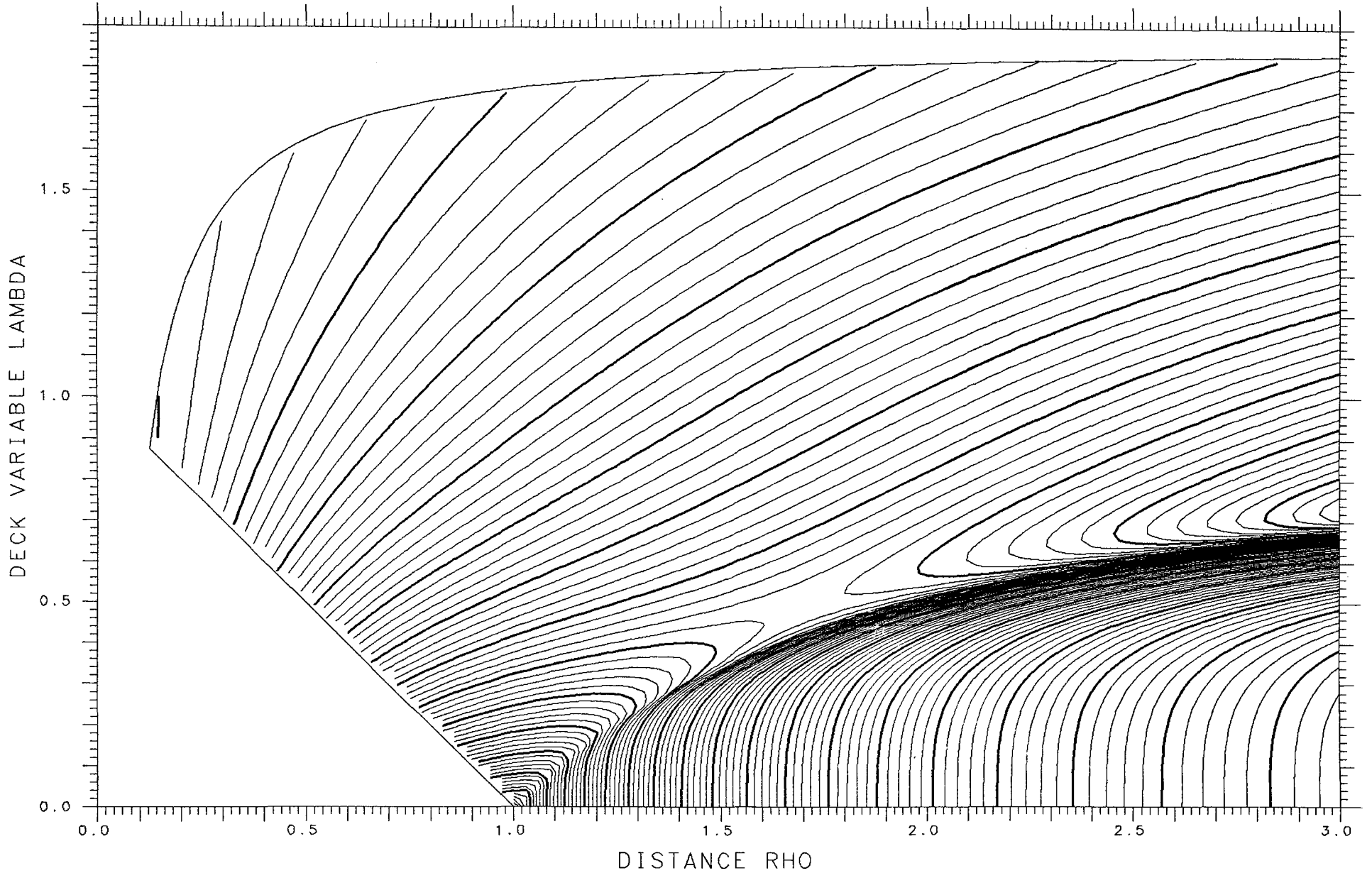

X= .875 ASYMMETRY DELTA= .250 FRACTIONAL= .8224

SPHERES -.19478 TANGENT .08944 LENGTH 11.903 ENERGY 682.43 SPACING .002 SADDLE .00853

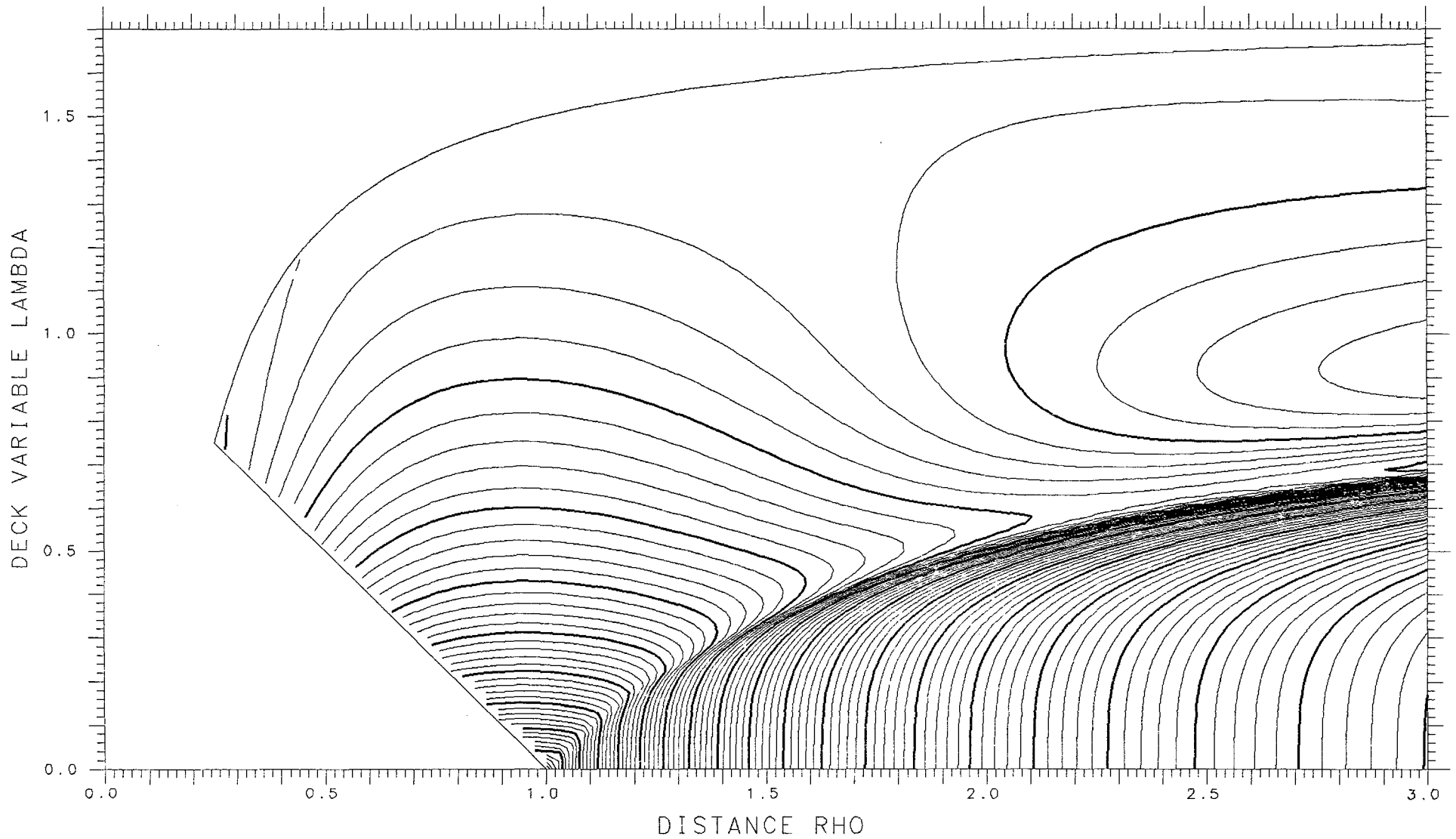

X= .600 ASYMMETRY DELTA= .150 FRACTIONAL= .7124

SPHERES -.13439 TANGENT .12946 LENGTH 10.597 ENERGY 522.49 SPACING .002 SADDLE .07083

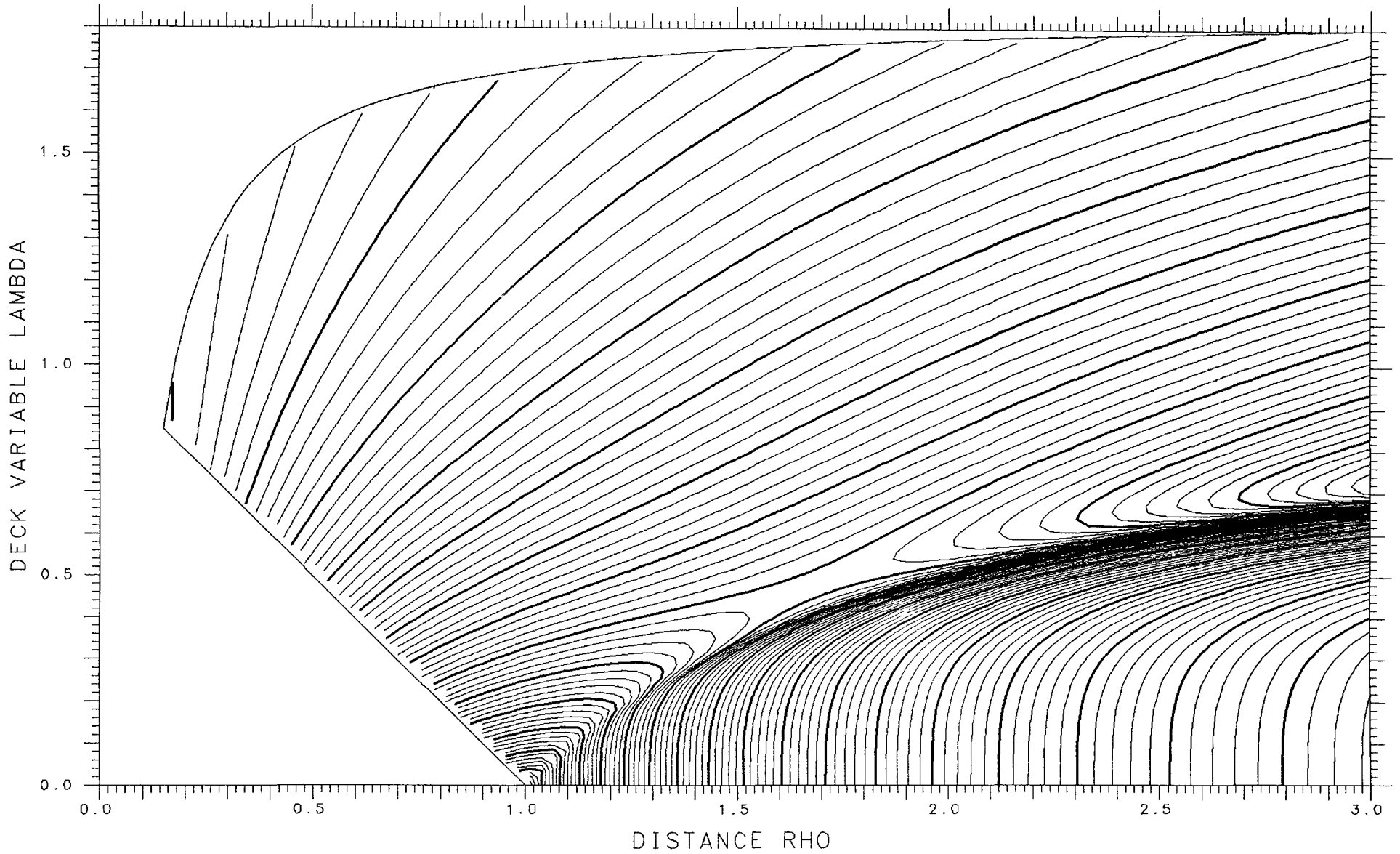

X= .875 ASYMMETRY DELTA= .225 FRACTIONAL= .7979

SPHERES -.22229 TANGENT .08824 LENGTH 12.024 ENERGY 682.43 SPACING .002 SADDLE -.00254

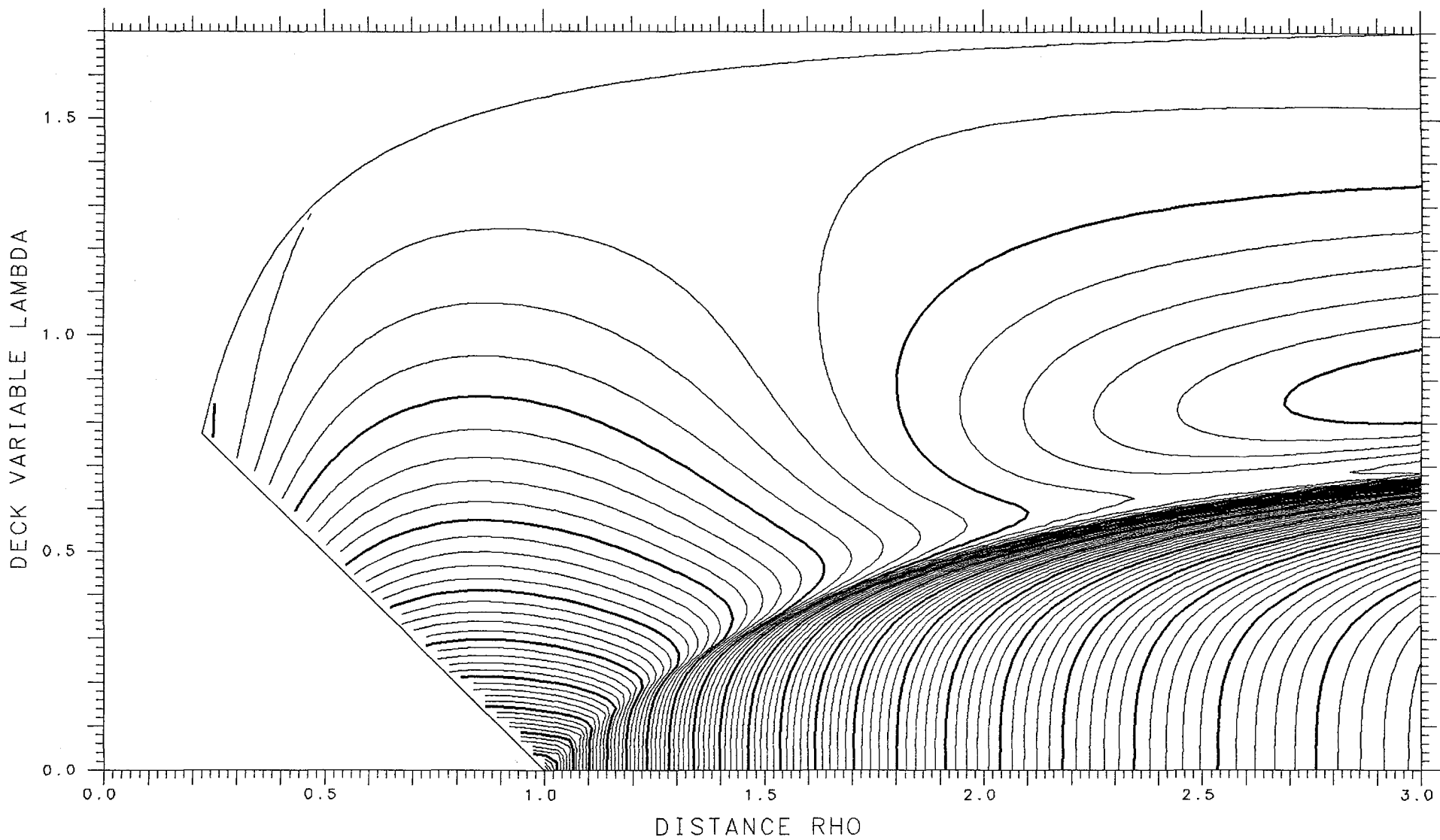

X= .600 ASYMMETRY DELTA= .175 FRACTIONAL= .7429

SPHERES -.11943 TANGENT .12839 LENGTH 10.517 ENERGY 522.49 SPACING .002 SADDLE .07416

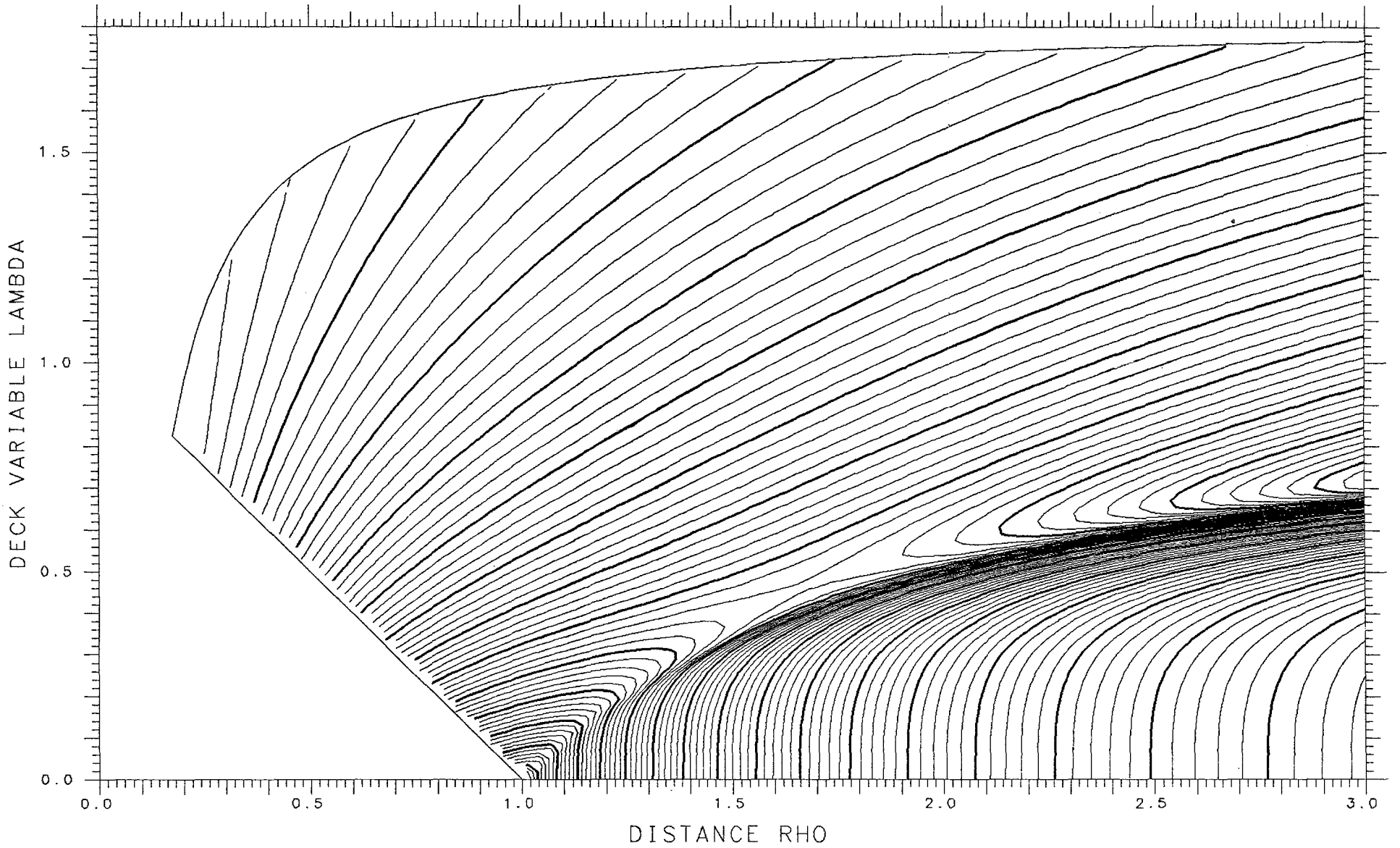

X= .875 ASYMMETRY DELTA= .200 FRACTIONAL= .7714

SPHERES -.24997 TANGENT .08648 LENGTH 12.137 ENERGY 682.43 SPACING .002 SADDLE -.01368

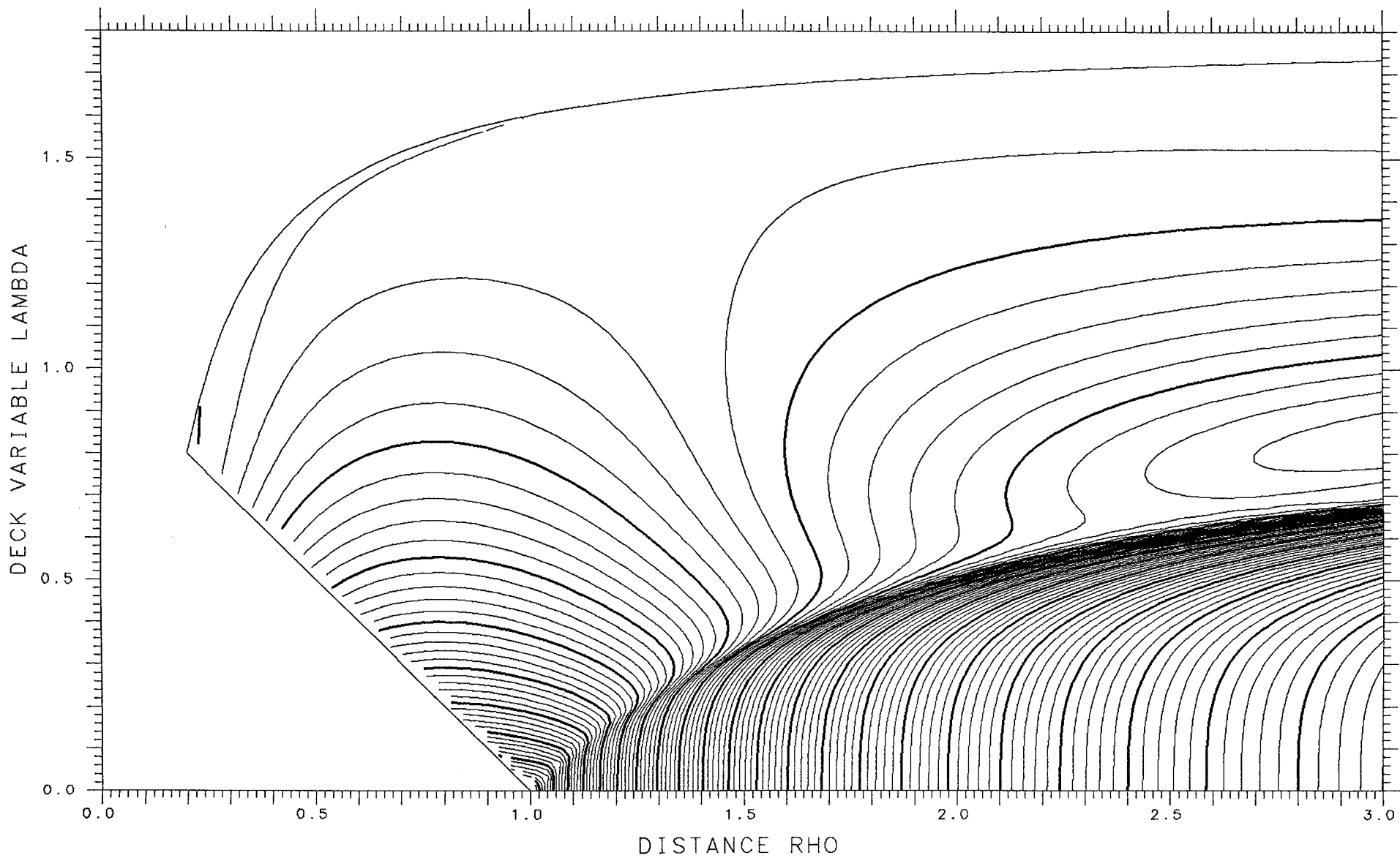

X= .600 ASYMMETRY DELTA= .200 FRACTIONAL= .7714

SPHERES -.10385 TANGENT .12686 LENGTH 10.428 ENERGY 522.49 SPACING .002 SADDLE .07740

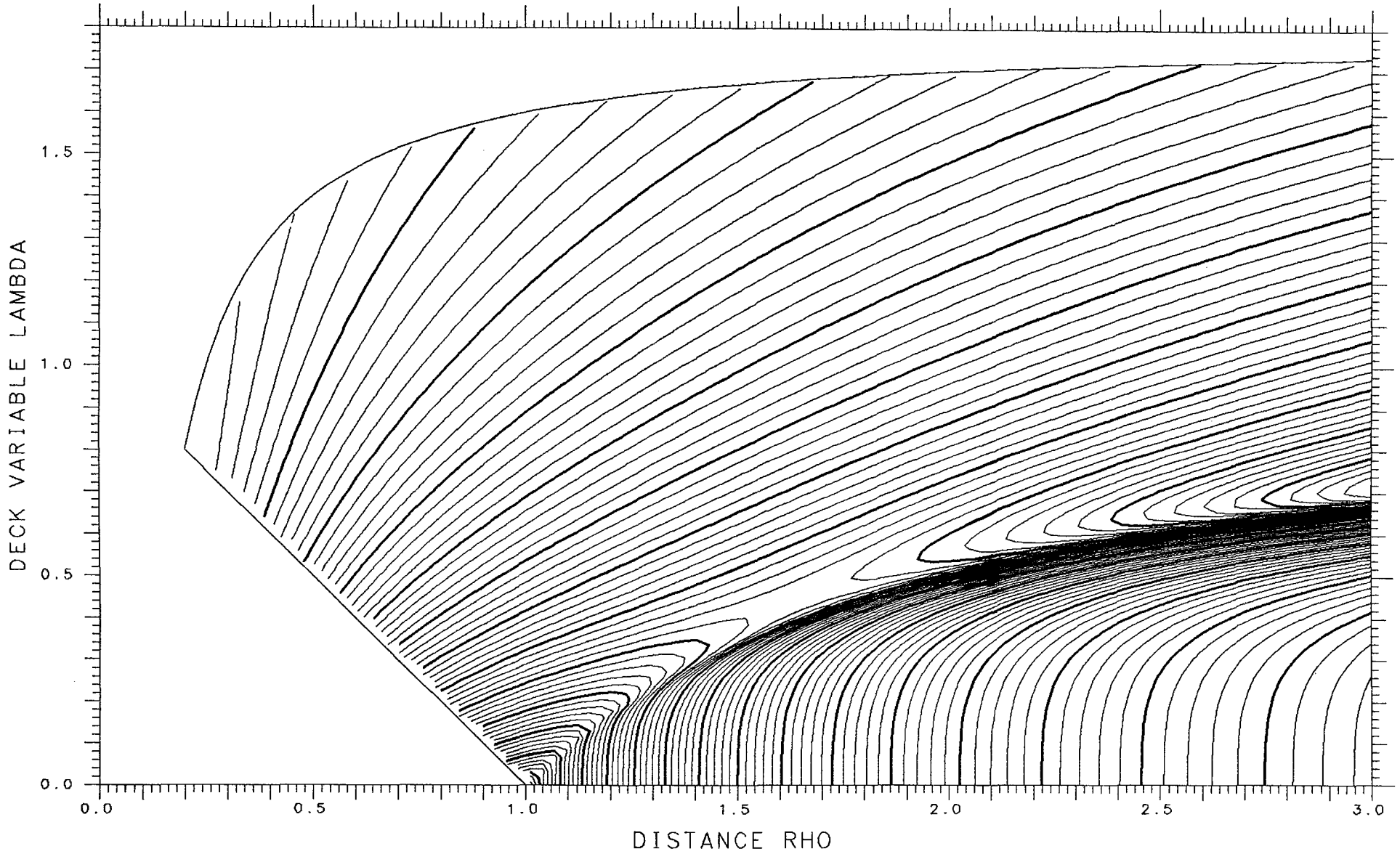

X= .875 ASYMMETRY DELTA= .175 FRACTIONAL= .7429

SPHERES -.27712 TANGENT .08429 LENGTH 12.240 ENERGY 682.43 SPACING .002 SADDLE -.02419

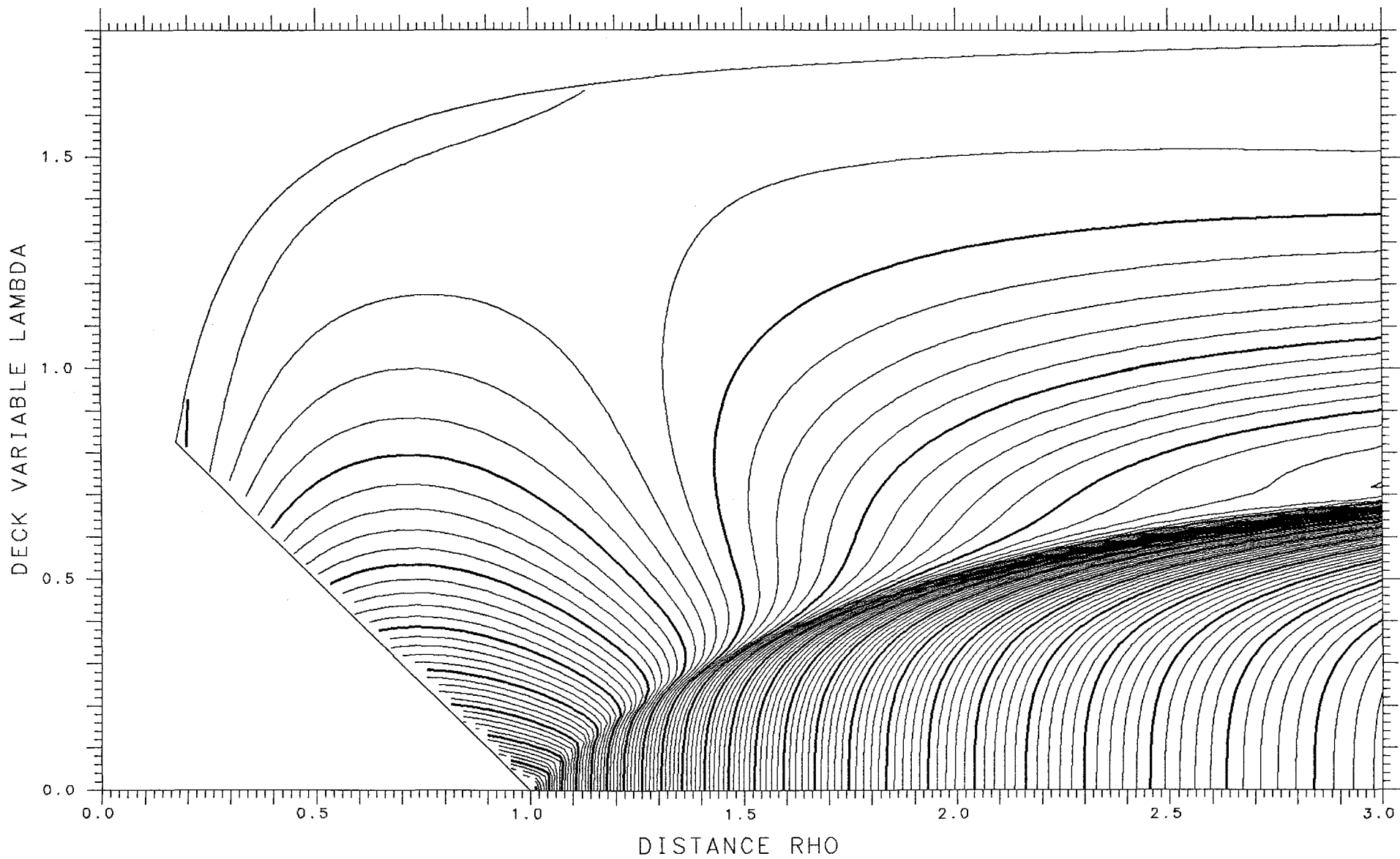

X= .600 ASYMMETRY DELTA= .225 FRACTIONAL= .7979

SPHERES -.08812 TANGENT .12482 LENGTH 10.331 ENERGY 522.49 SPACING .002 SADDLE .08034

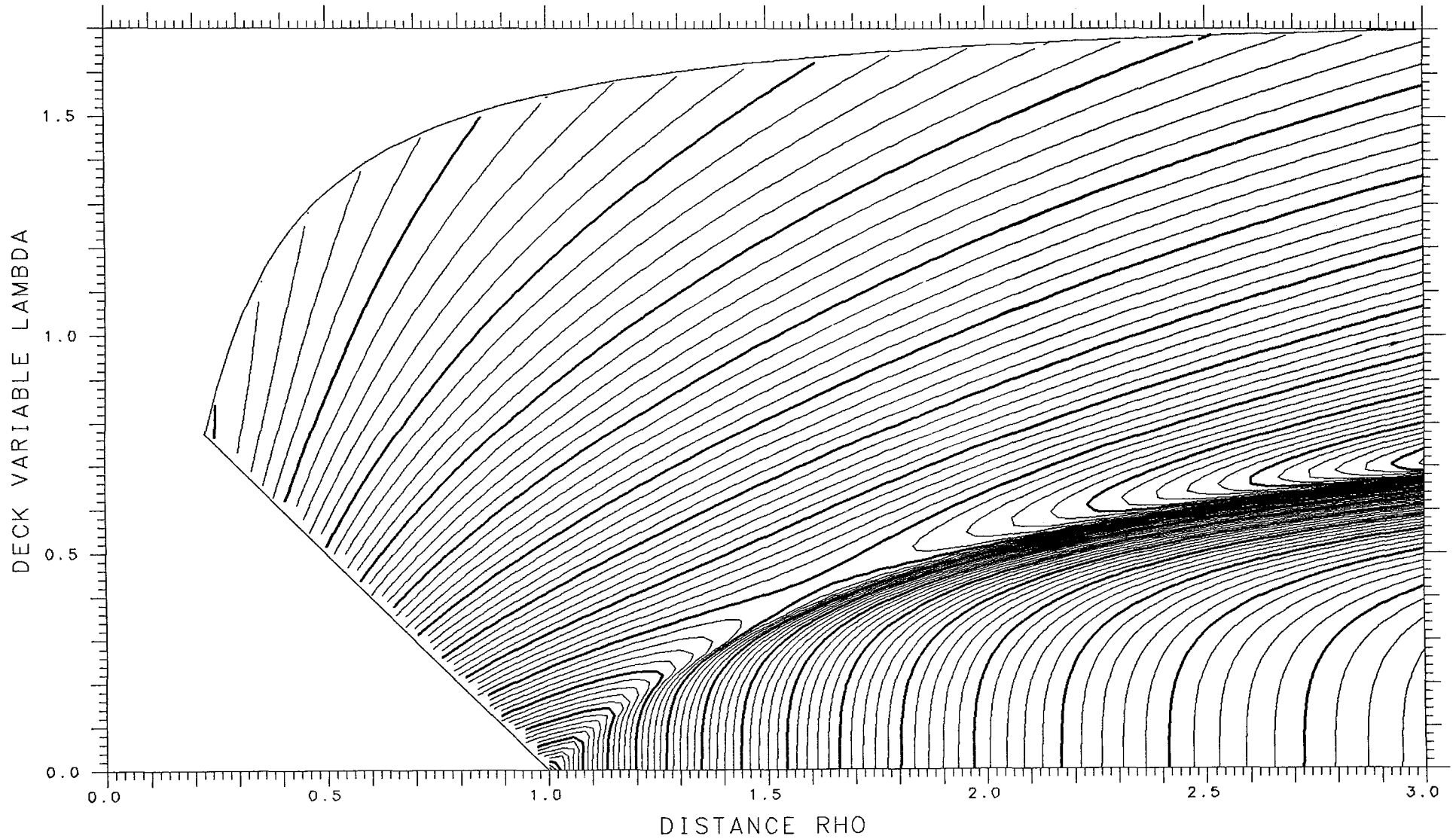

X= .875 ASYMMETRY DELTA= .150 FRACTIONAL= .7124

SPHERES -.30295 TANGENT .08183 LENGTH 12.333 ENERGY 682.43 SPACING .002 SADDLE .00217

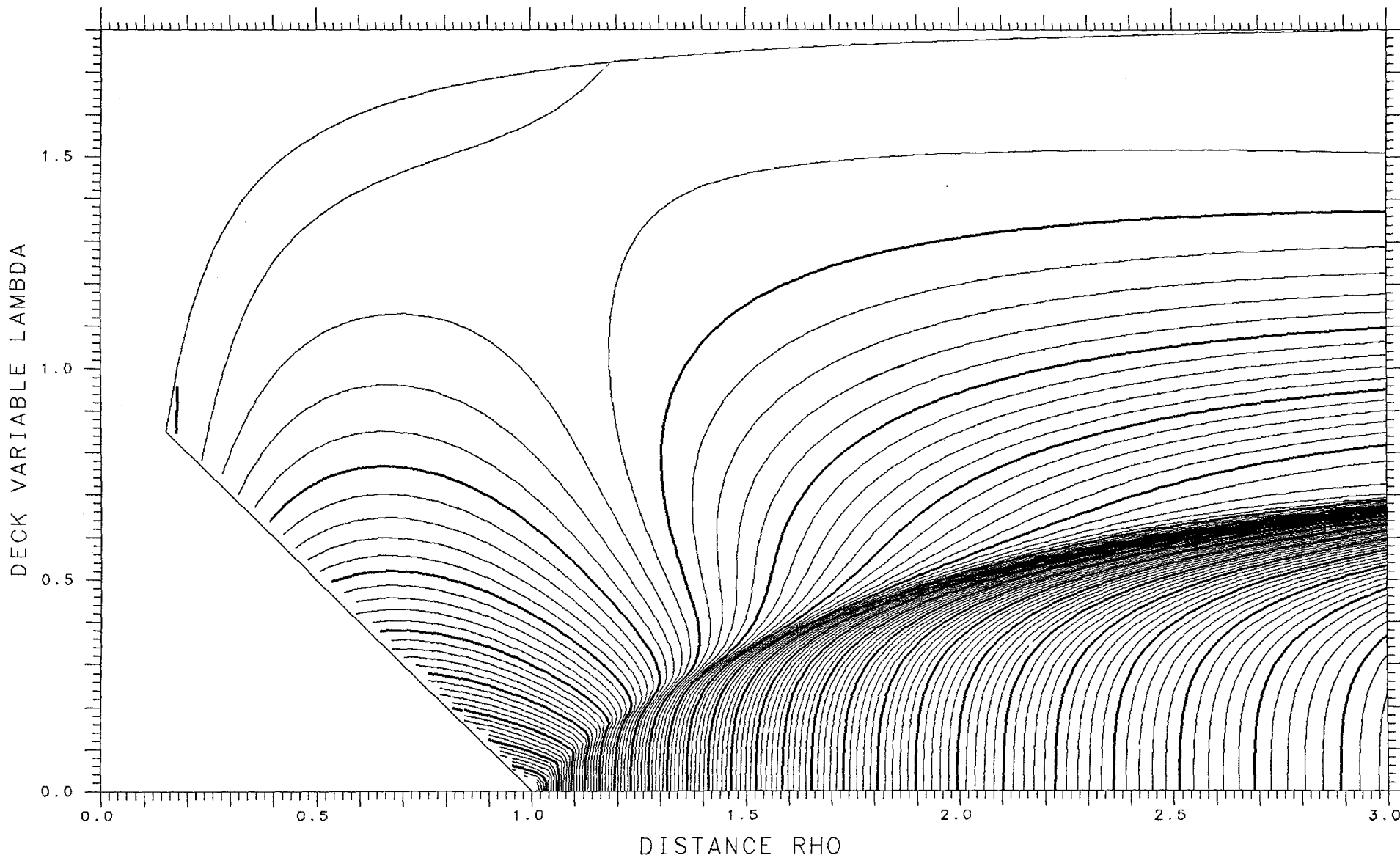

X= .600 ASYMMETRY DELTA= .250 FRACTIONAL= .8224

SPHERES -.07267 TANGENT .12223 LENGTH 10.227 ENERGY 522.49 SPACING .002 SADDLE .08279

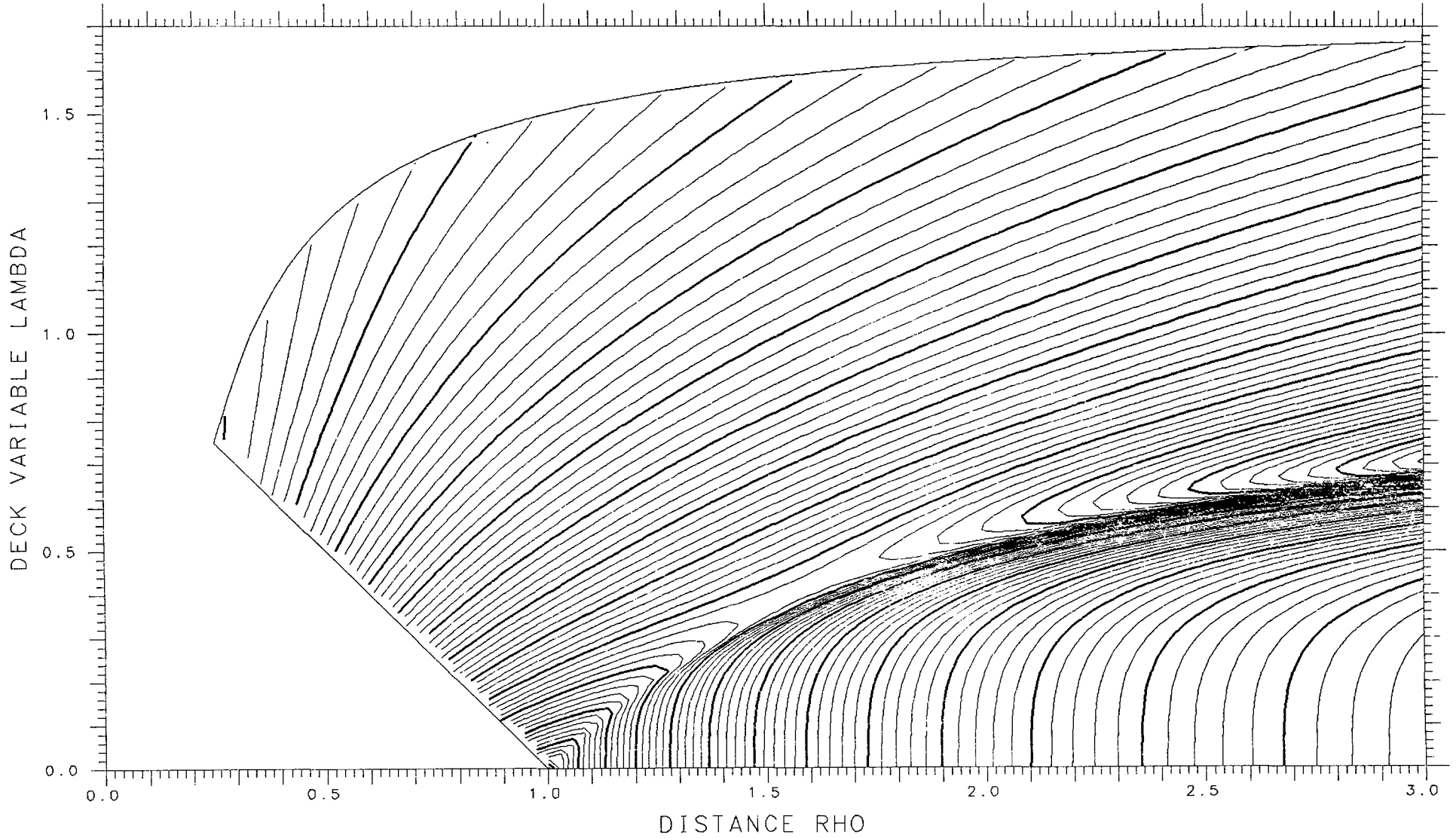

X= .875 ASYMMETRY DELTA= .125 FRACTIONAL= .6800

SPHERES -.32665 TANGENT .07929 LENGTH 12.413 ENERGY 682.43 SPACING .002 SADDLE .00208

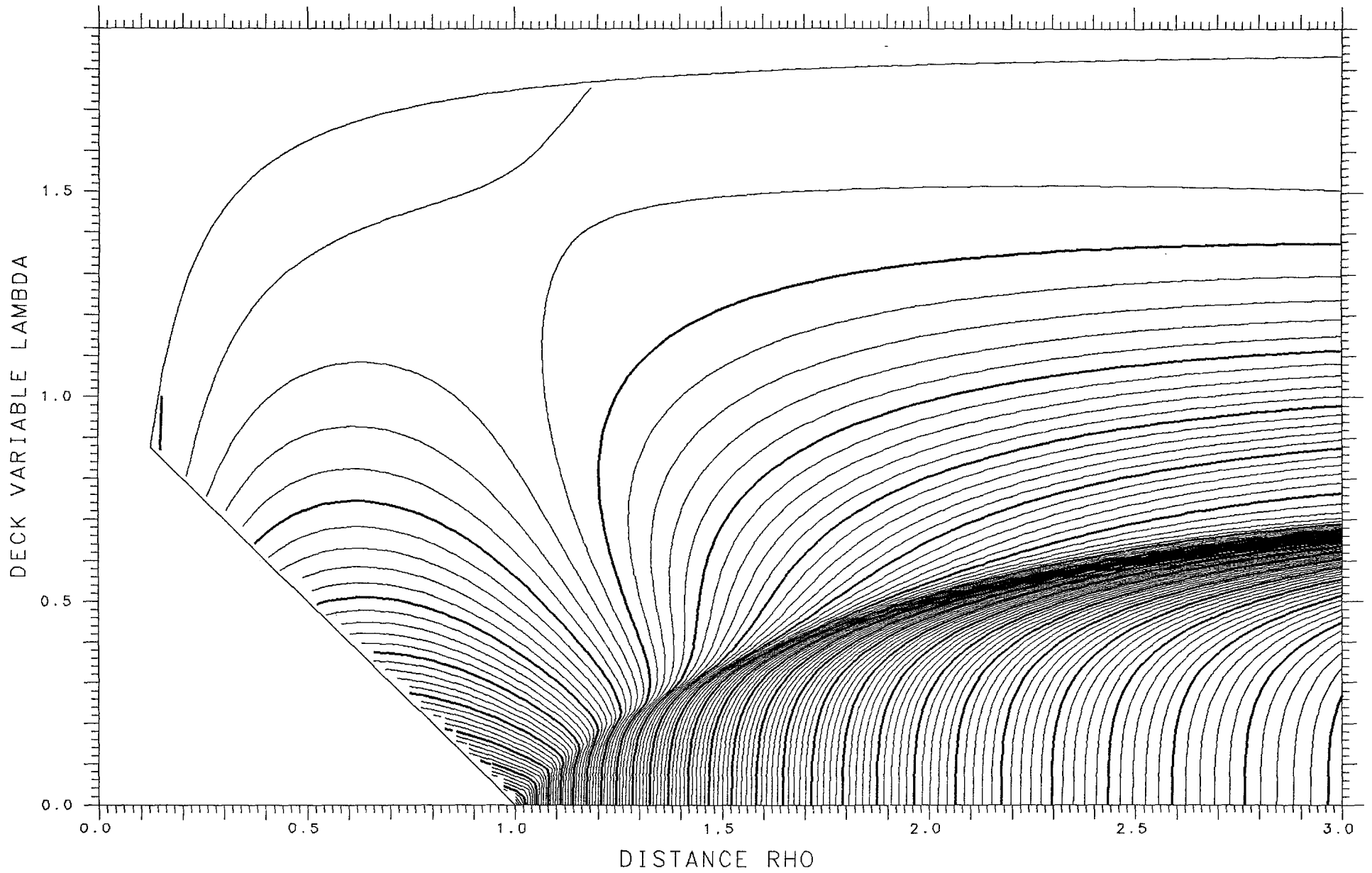

X= .600 ASYMMETRY DELTA= .275 FRACTIONAL= .8447

SPHERES -.05788 TANGENT .11906 LENGTH 10.116 ENERGY 522.49 SPACING .002 SADDLE .08457

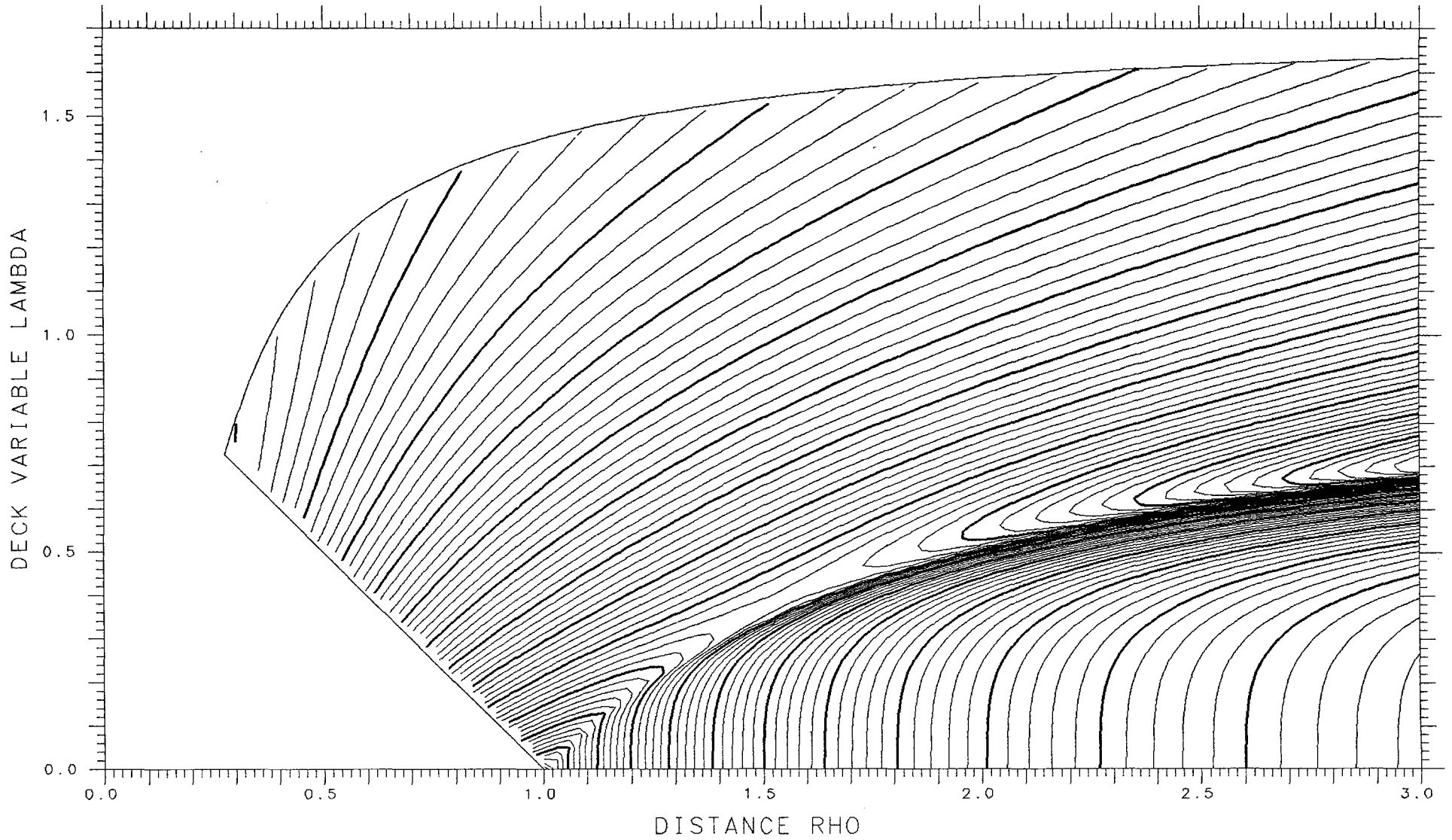

X = .875

ASYMMETRY DELTA = .100

FRACTIONAL = .6461

SPHERES -.34741

TANGENT .07687

LENGTH 12.481

ENERGY 682.43

SPACING .002

SADDLE .00197

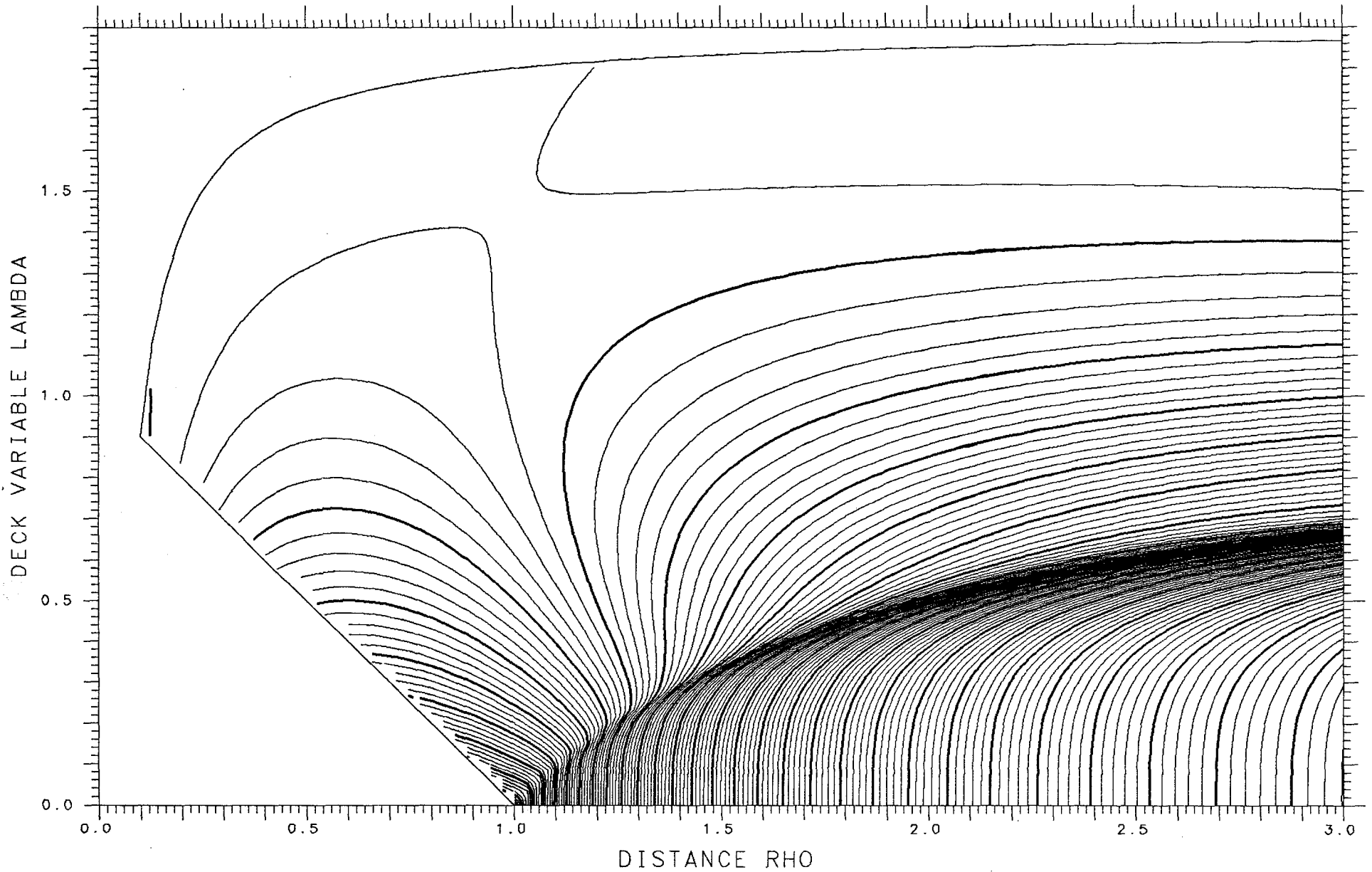

X= .600 ASYMMETRY DELTA= .300 FRACTIONAL= .8650

SPHERES -.04405 TANGENT .11532 LENGTH 10.001 ENERGY 522.49 SPACING .002 SADDLE .08557

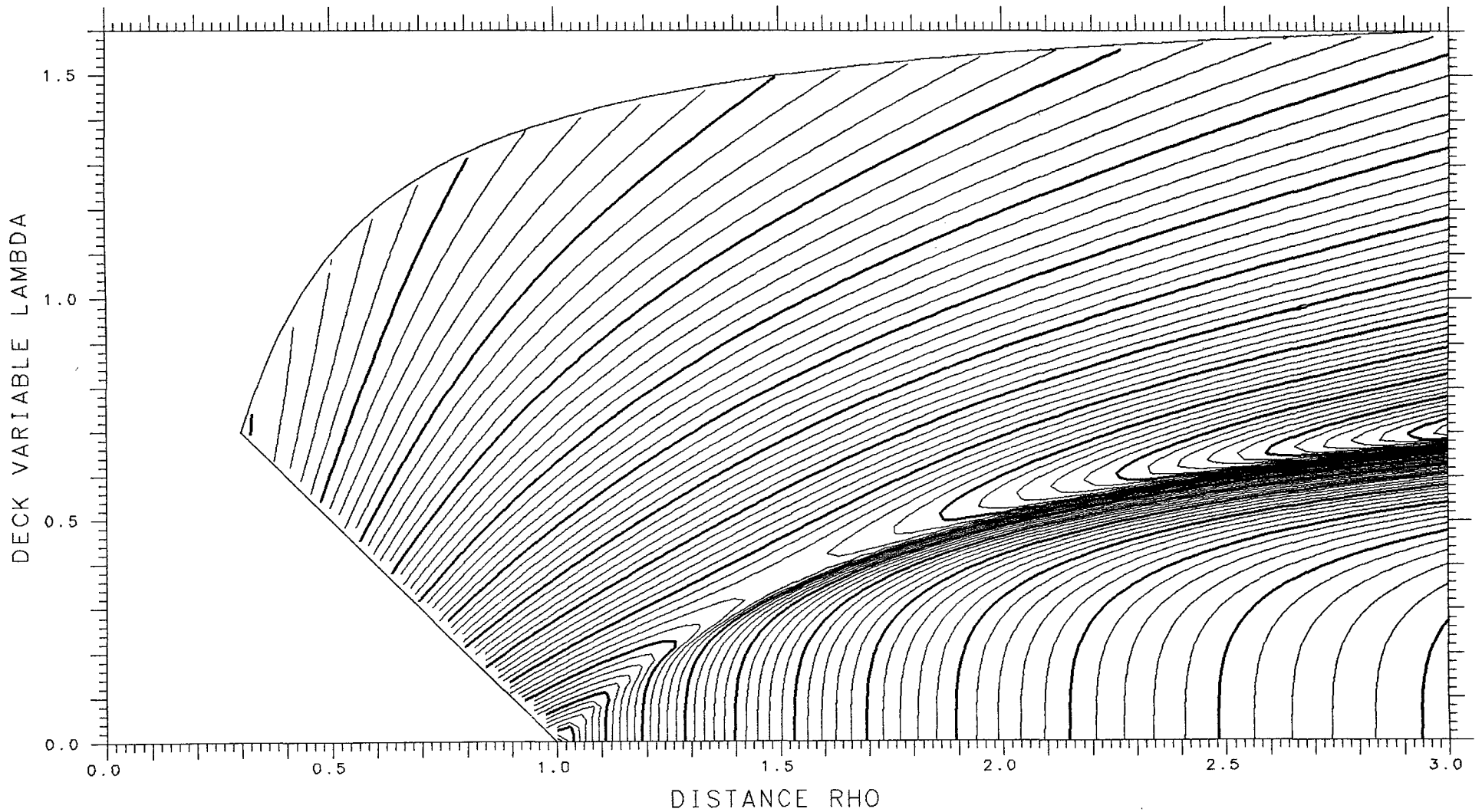

X= .875 ASYMMETRY DELTA= .075 FRACTIONAL= .6108

SPHERES -.36446 TANGENT .07475 LENGTH 12.534 ENERGY 682.43 SPACING .002 SADDLE .00185

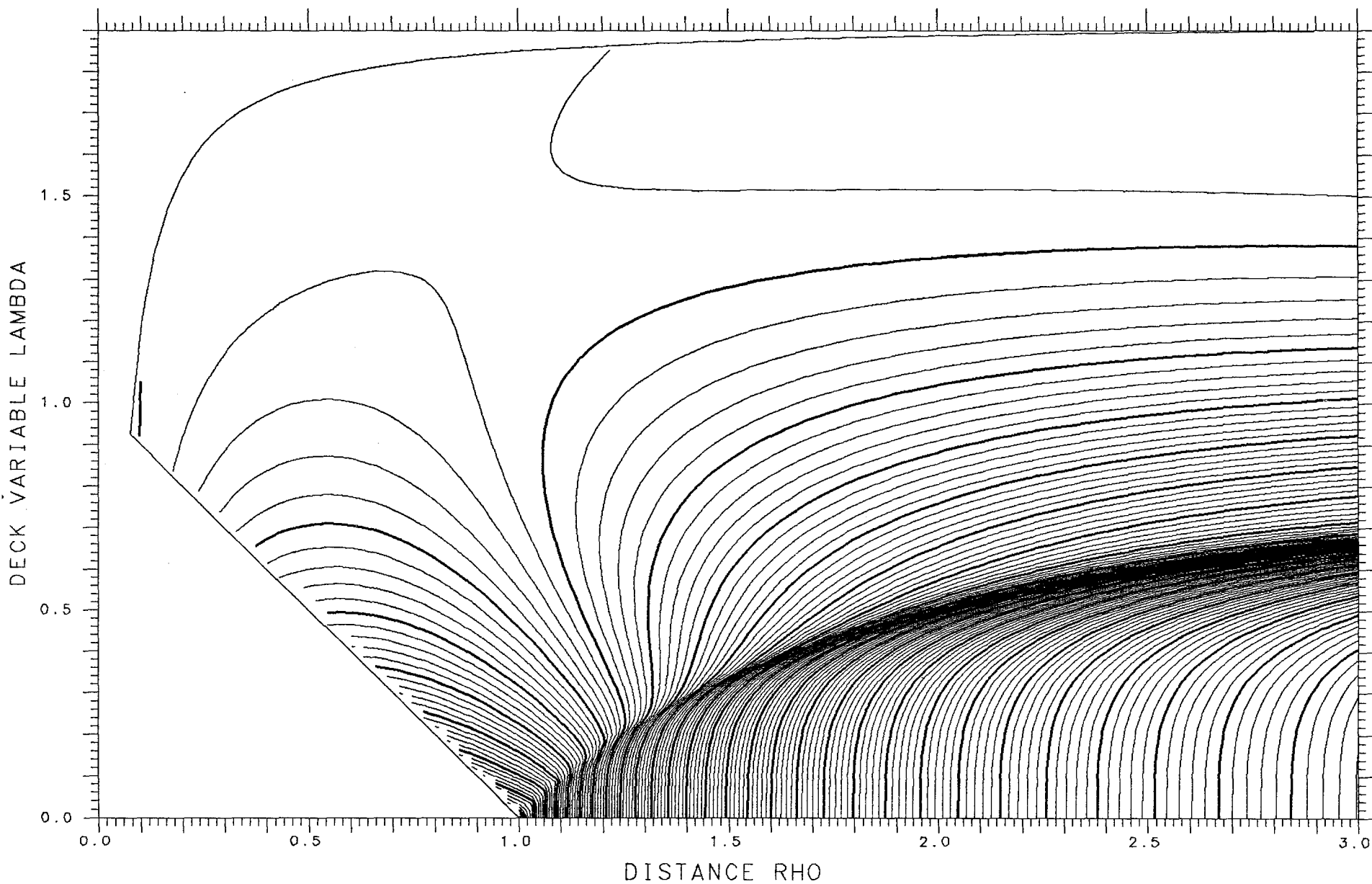

X= .600 ASYMMETRY DELTA= .325 FRACTIONAL= .8832

SPHERES -.03140 TANGENT .11103 LENGTH 9.880 ENERGY 522.49 SPACING .002 SADDLE .08573

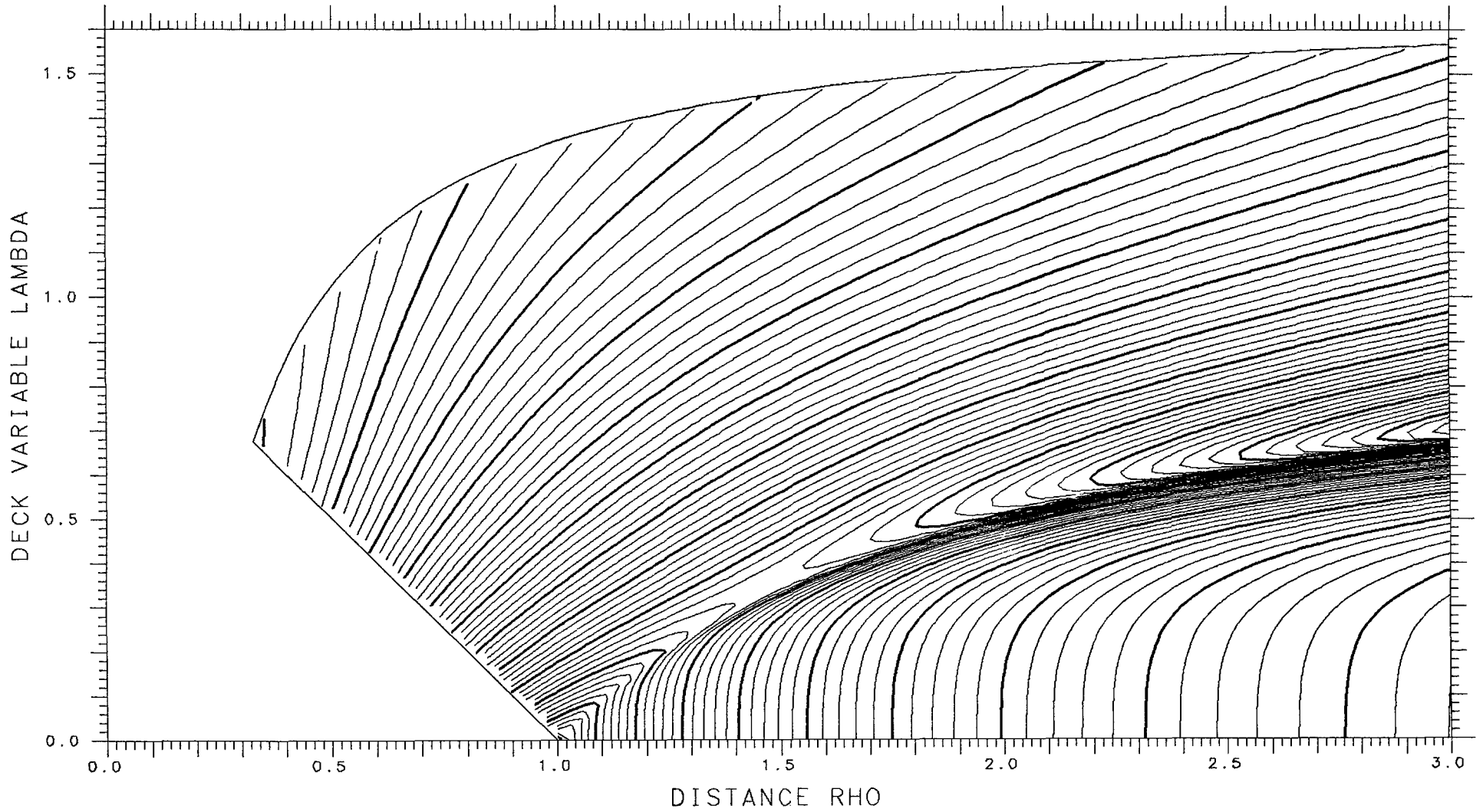

X = .875 ASYMMETRY DELTA = .050 FRACTIONAL = .5745

SPHERES - .37716 TANGENT .07310 LENGTH 12.573 ENERGY 682.43 SPACING .002 SADDLE .00174

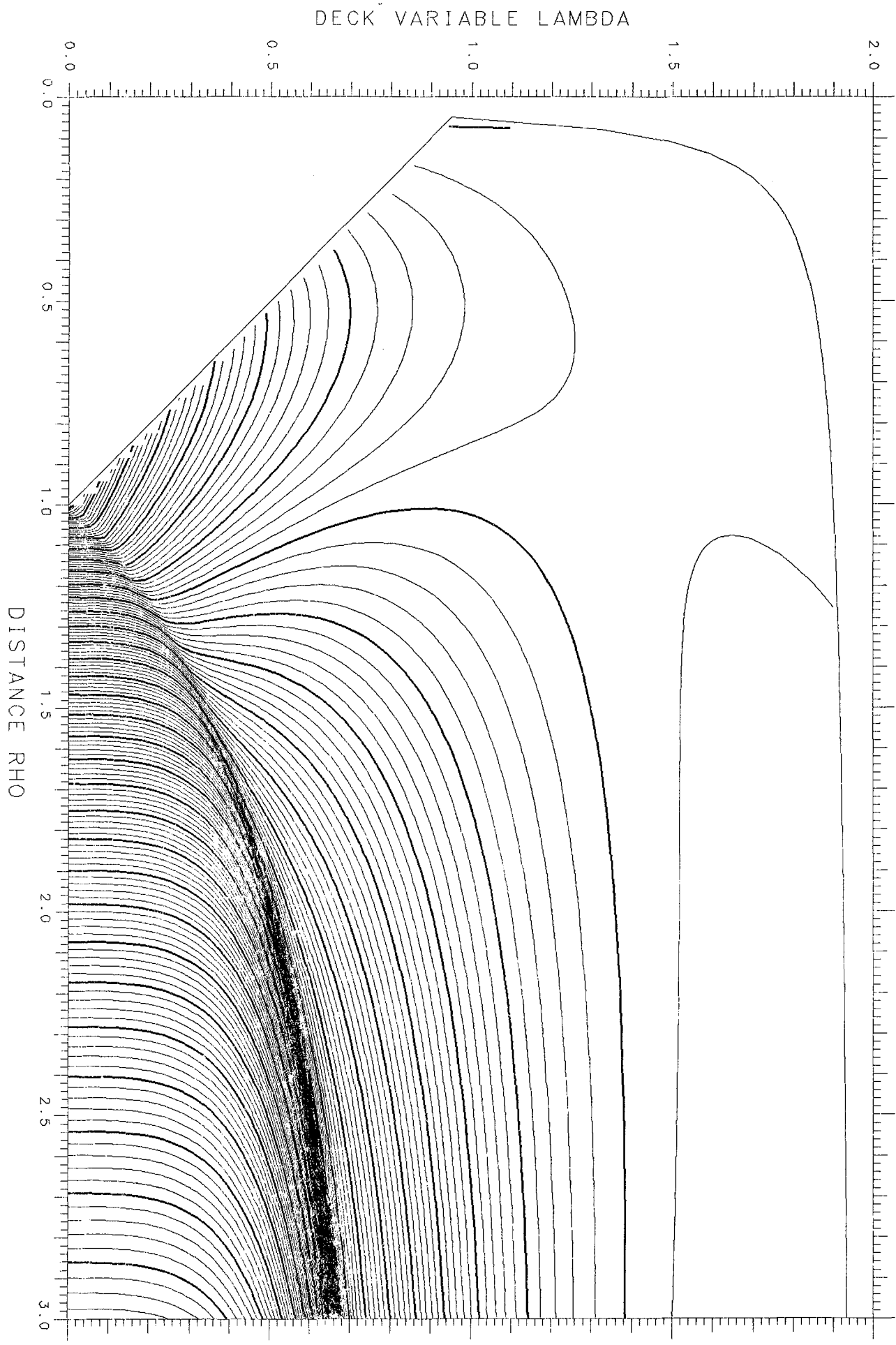

X= .600 ASYMMETRY DELTA= .350 FRACTIONAL= .8996

SPHERES -.02007 TANGENT .10625 LENGTH 9.757 ENERGY 522.49 SPACING .002 SADDLE .08502

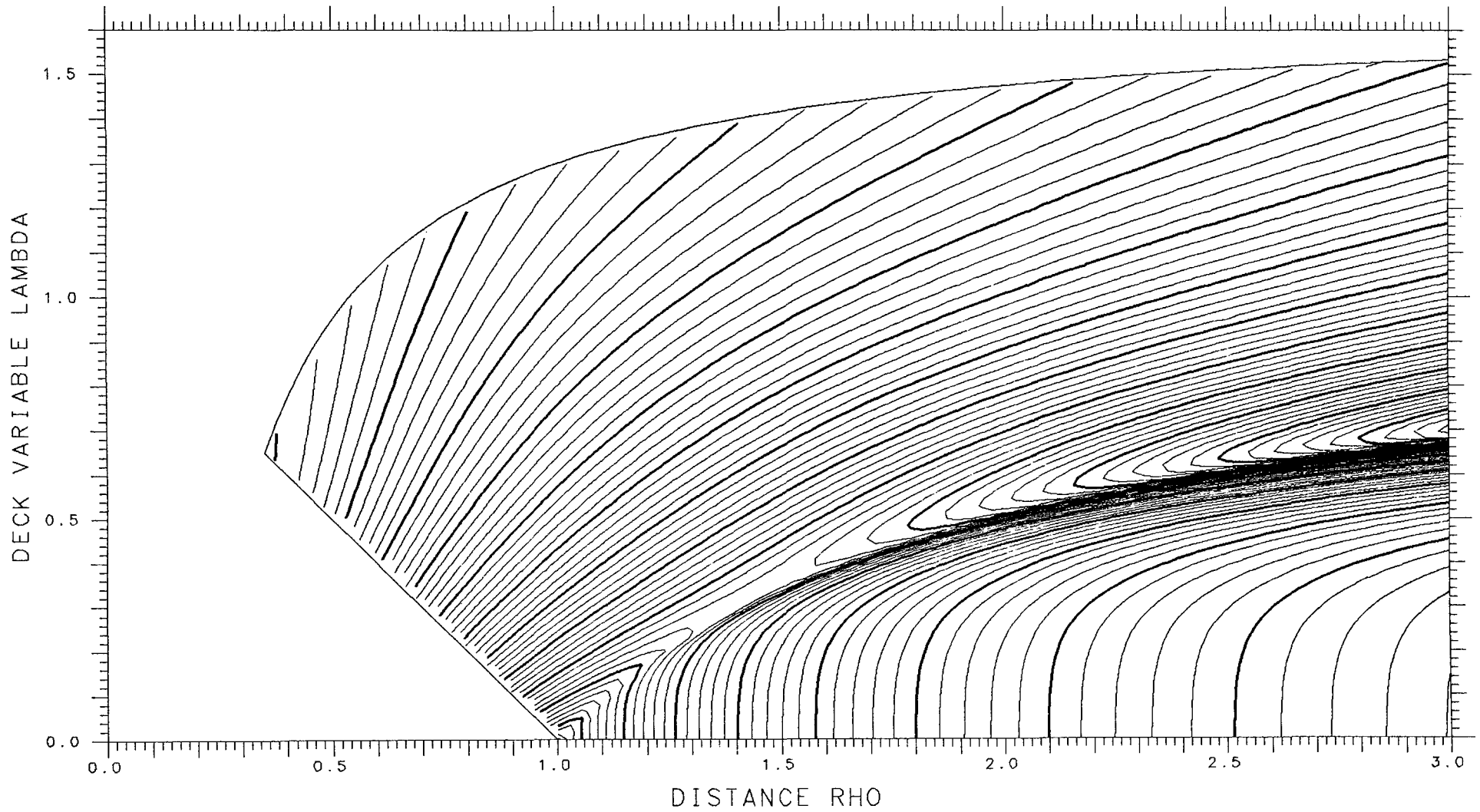

X= .875 ASYMMETRY DELTA= .025 FRACTIONAL= .5374

SPHERES -.38500 TANGENT .07206 LENGTH 12.597 ENERGY 682.43 SPACING .002 SADDLE .00166

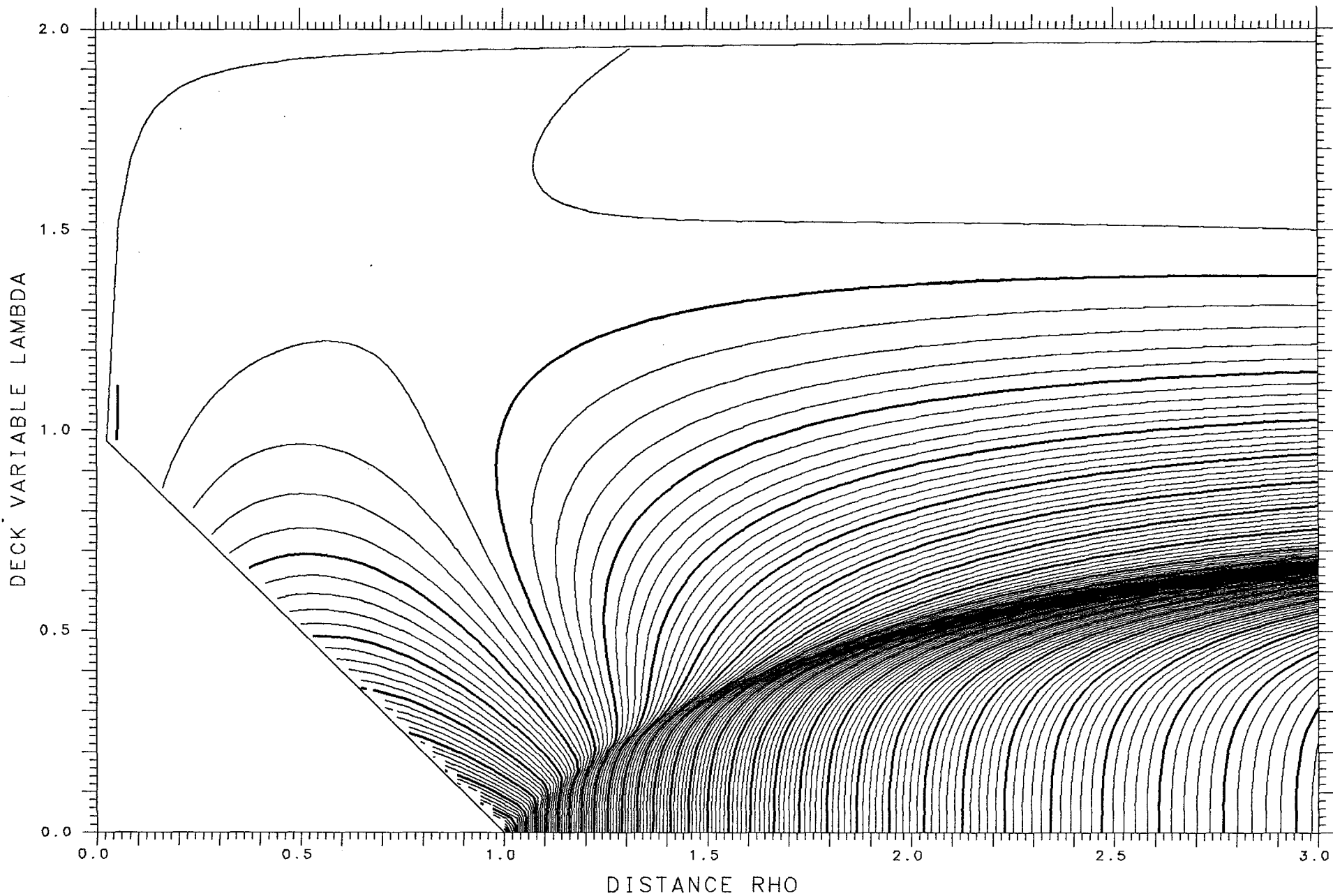

X= .600 ASYMMETRY DELTA= .375 FRACTIONAL= .9141

SPHERES -.01017 TANGENT .10102 LENGTH 9.631 ENERGY 522.49 SPACING .002 SADDLE .08345

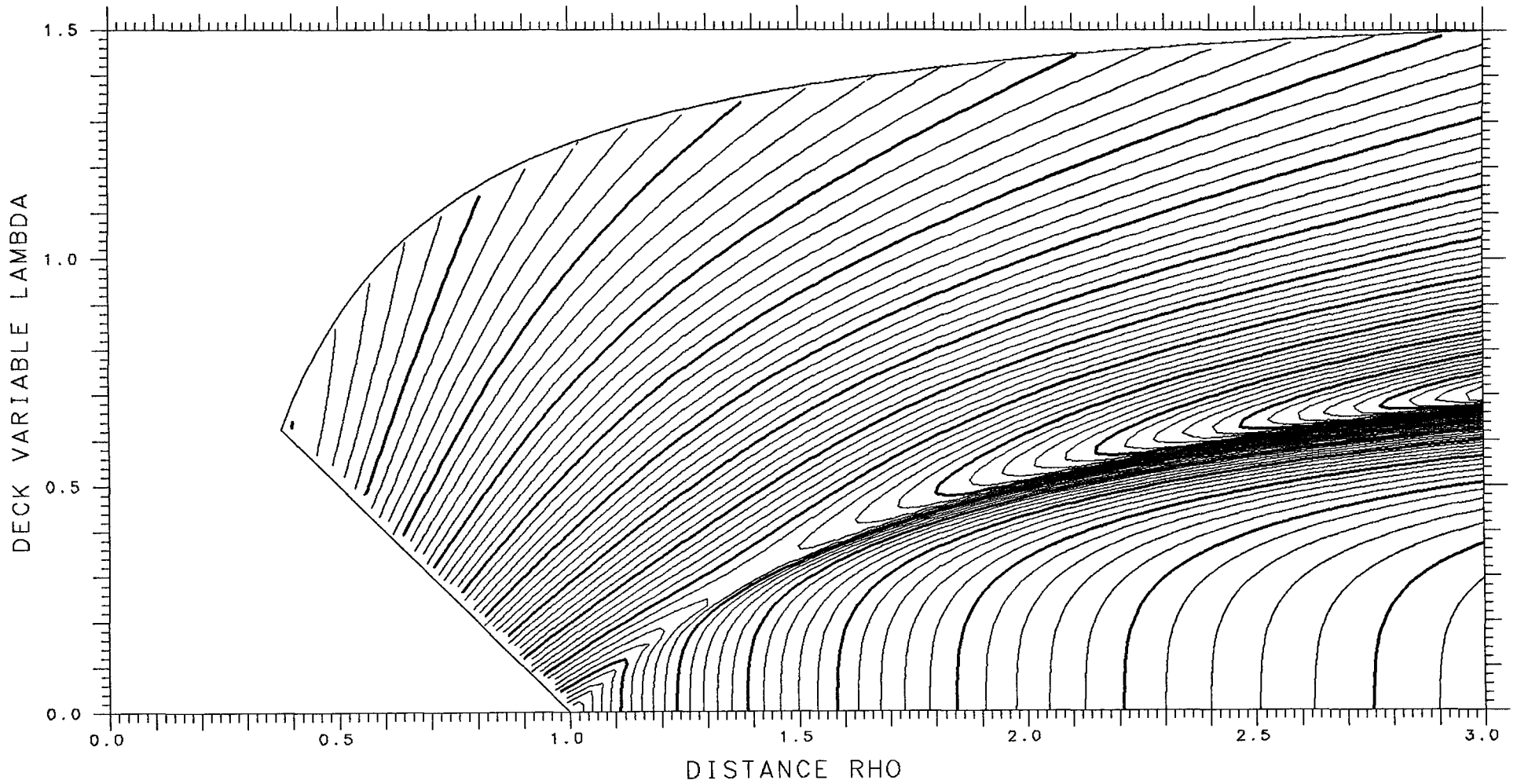

X= .875

ASYMMETRY DELTA=0.

FRACTIONAL= .5000

SPHERES -.38765

TANGENT .07170

LENGTH 12.604

ENERGY 682.43

SPACING .002

SADDLE .00163

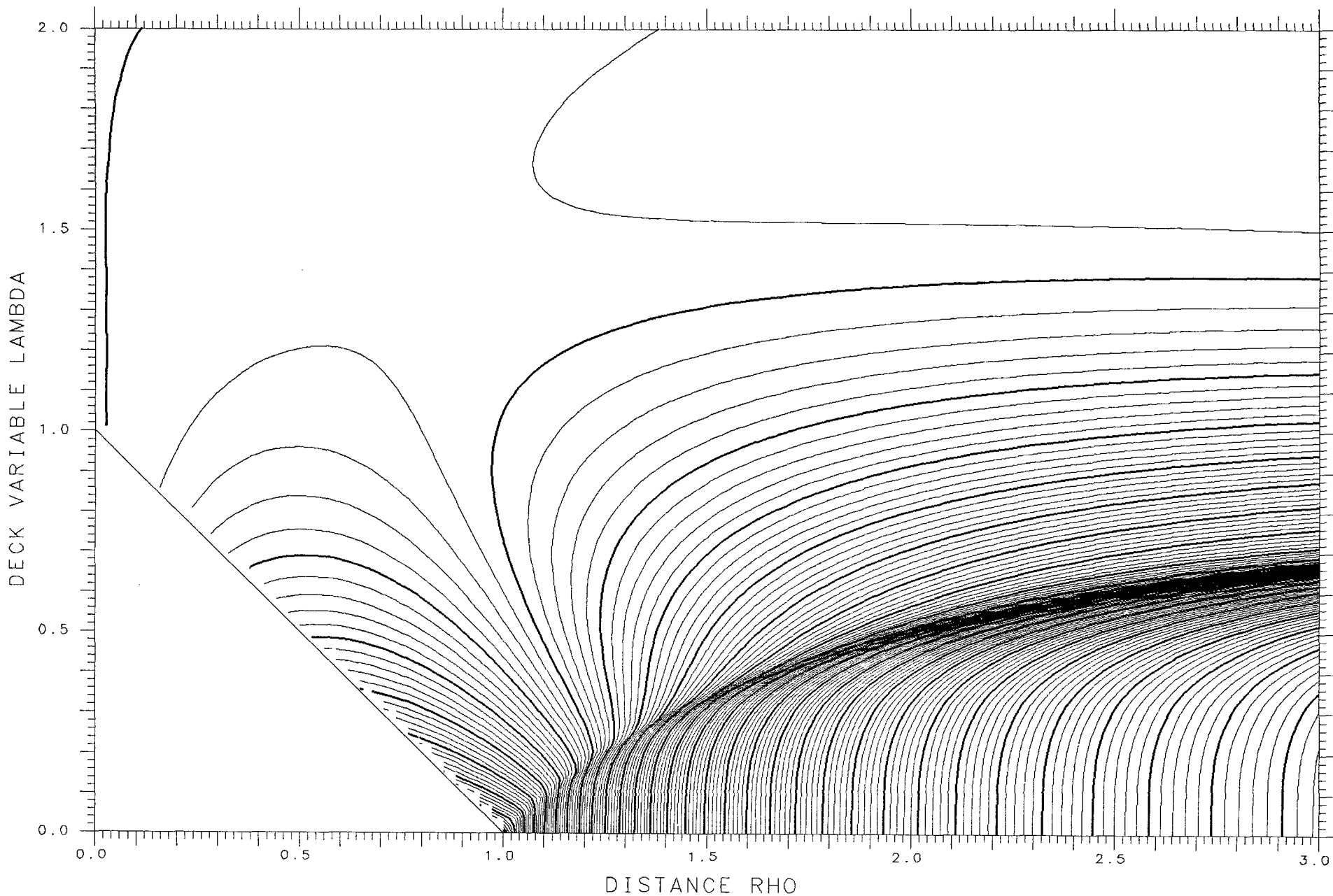

X= .600 ASYMMETRY DELTA= .400 FRACTIONAL= .9270

SPHERES --.00171 TANGENT .09542 LENGTH 9.503 ENERGY 522.49 SPACING .002

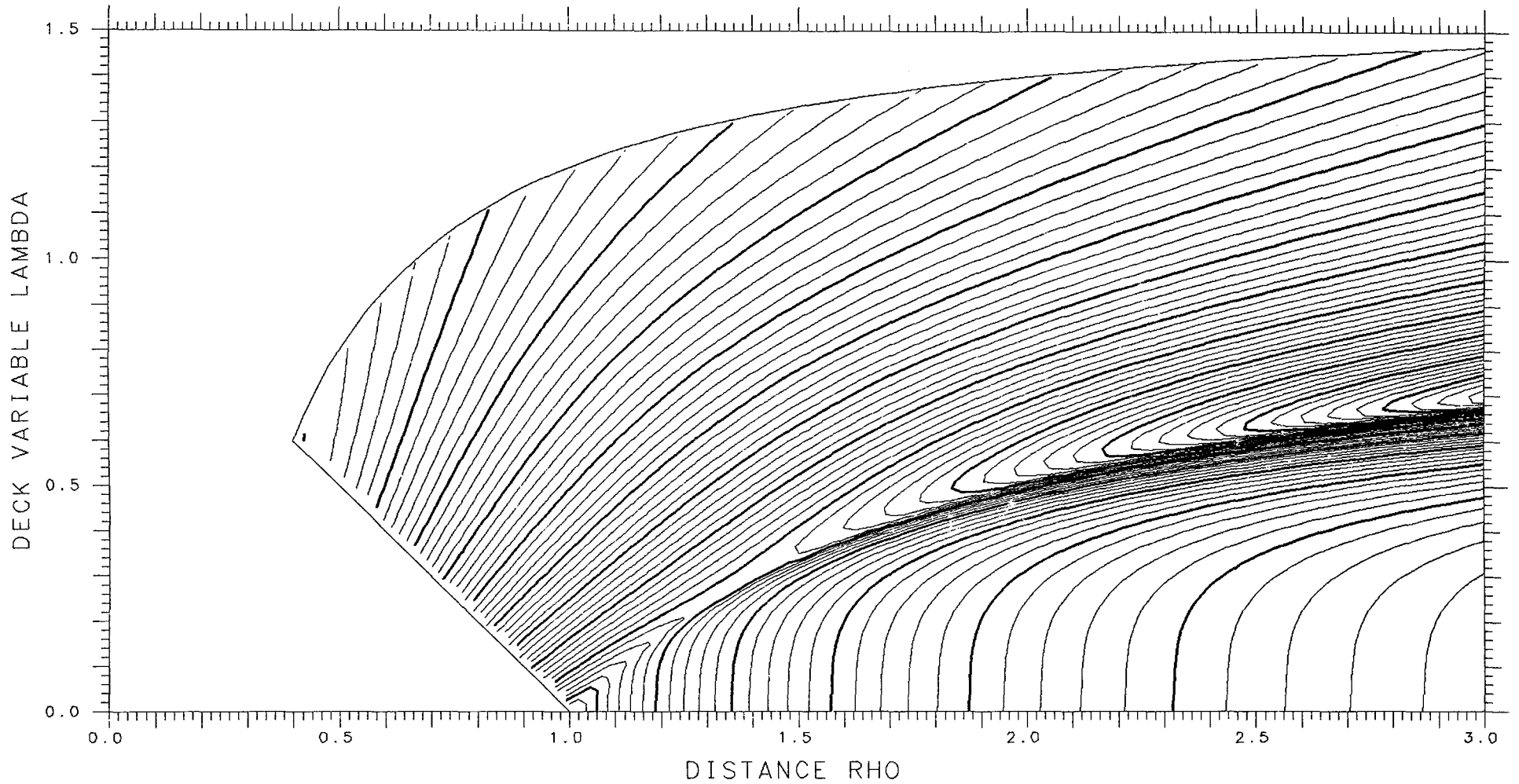

X= .850 ASYMMETRY DELTA= .600 FRACTIONAL= .9846

SPHERES .00983 TANGENT .04434 LENGTH 9.760 ENERGY 668.85 SPACING .002

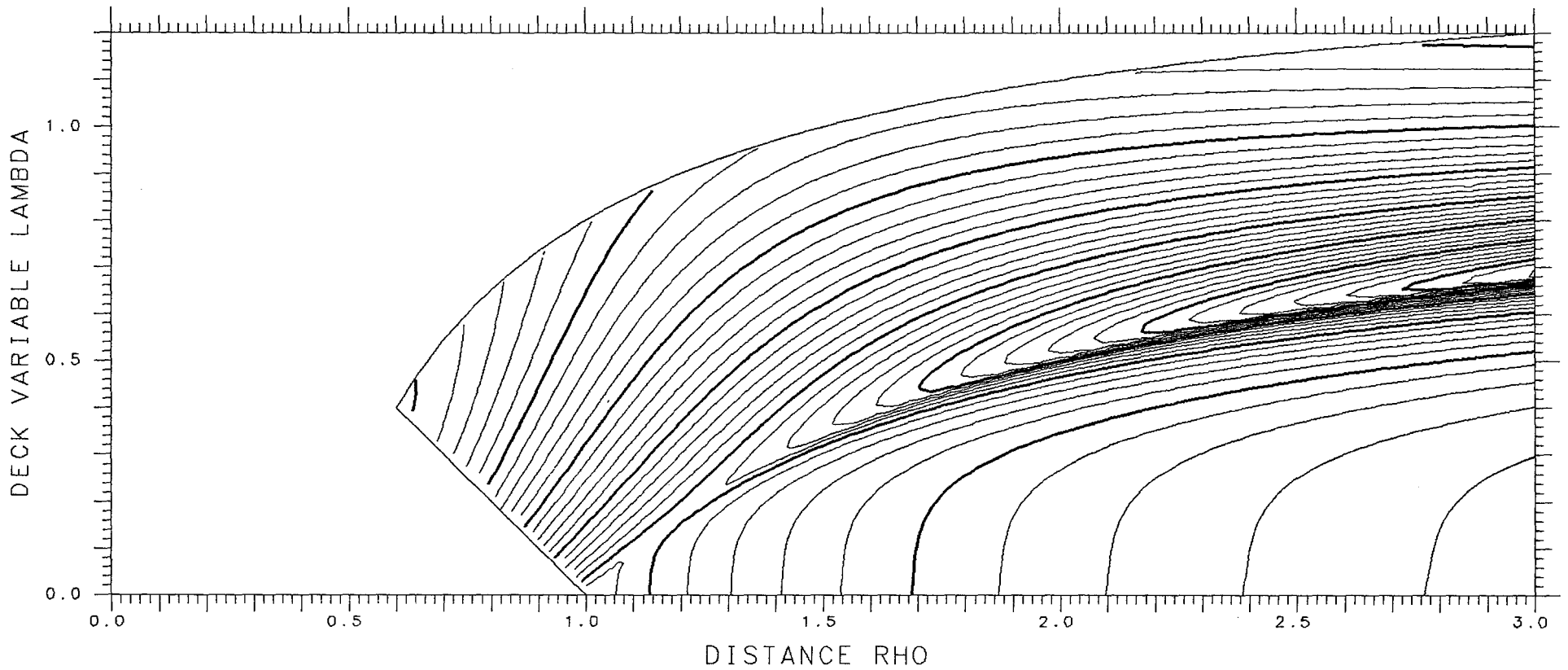

X= .600 ASYMMETRY DELTA= .425 FRACTIONAL= .9384

SPHERES .00532 TANGENT .08952 LENGTH 9.374 ENERGY 522.49 SPACING .002

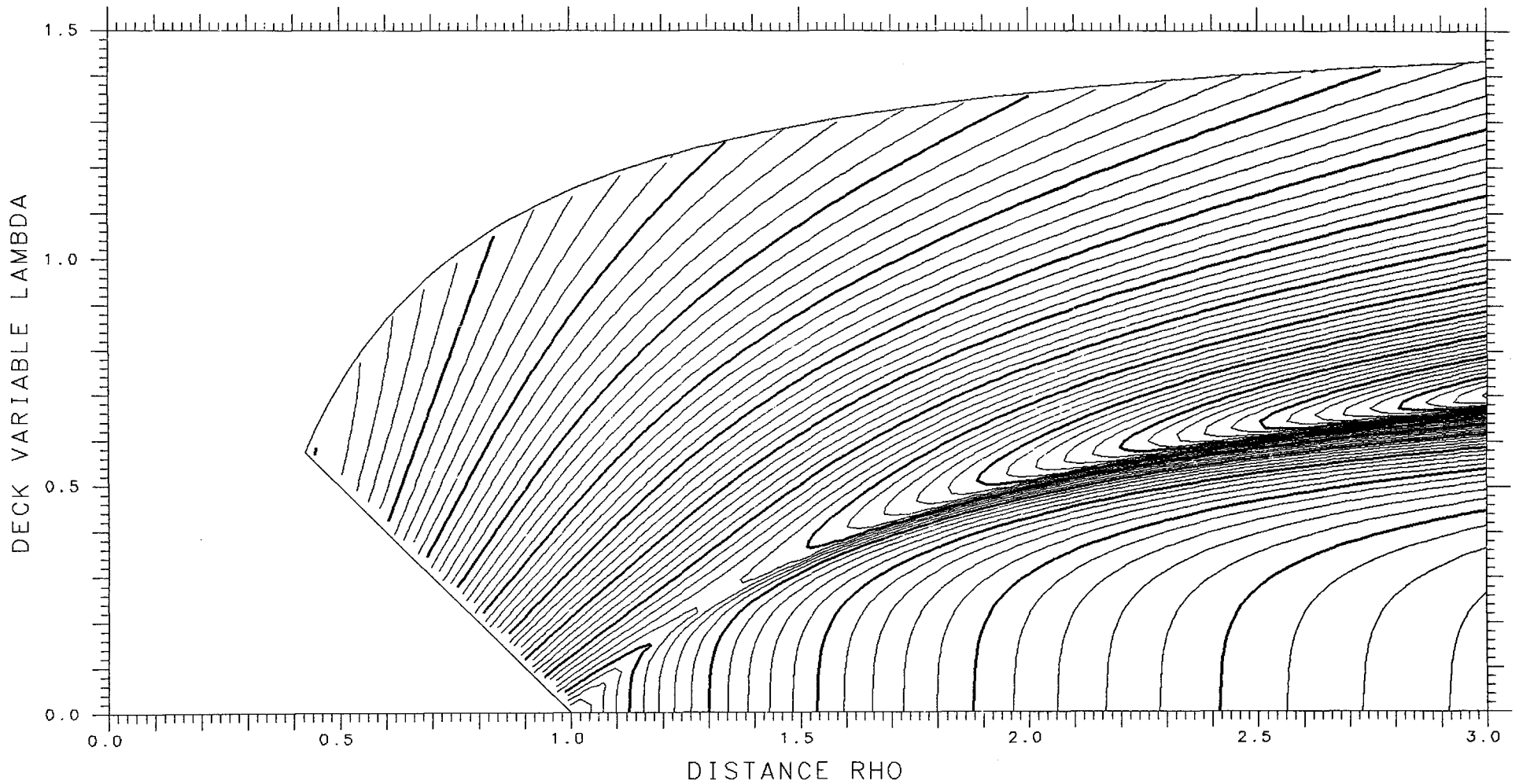

X= .850 ASYMMETRY DELTA= .575 FRACTIONAL= .9807

SPHERES .00710 TANGENT .04954 LENGTH 9.902 ENERGY 668.85 SPACING .002

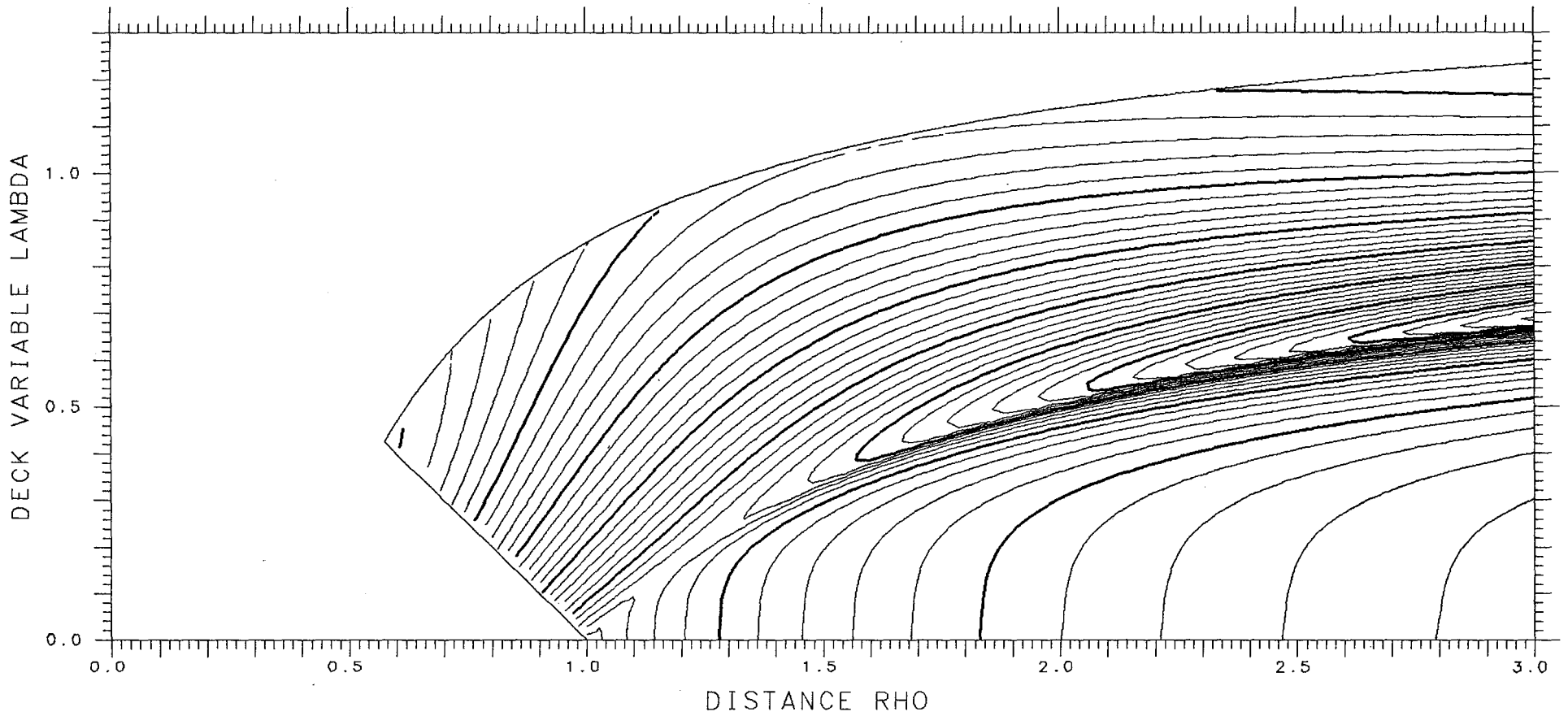

X= .600 ASYMMETRY DELTA= .450 FRACTIONAL= .9483

SPHERES .01098 TANGENT .08341 LENGTH 9.245 ENERGY 522.49 SPACING .002

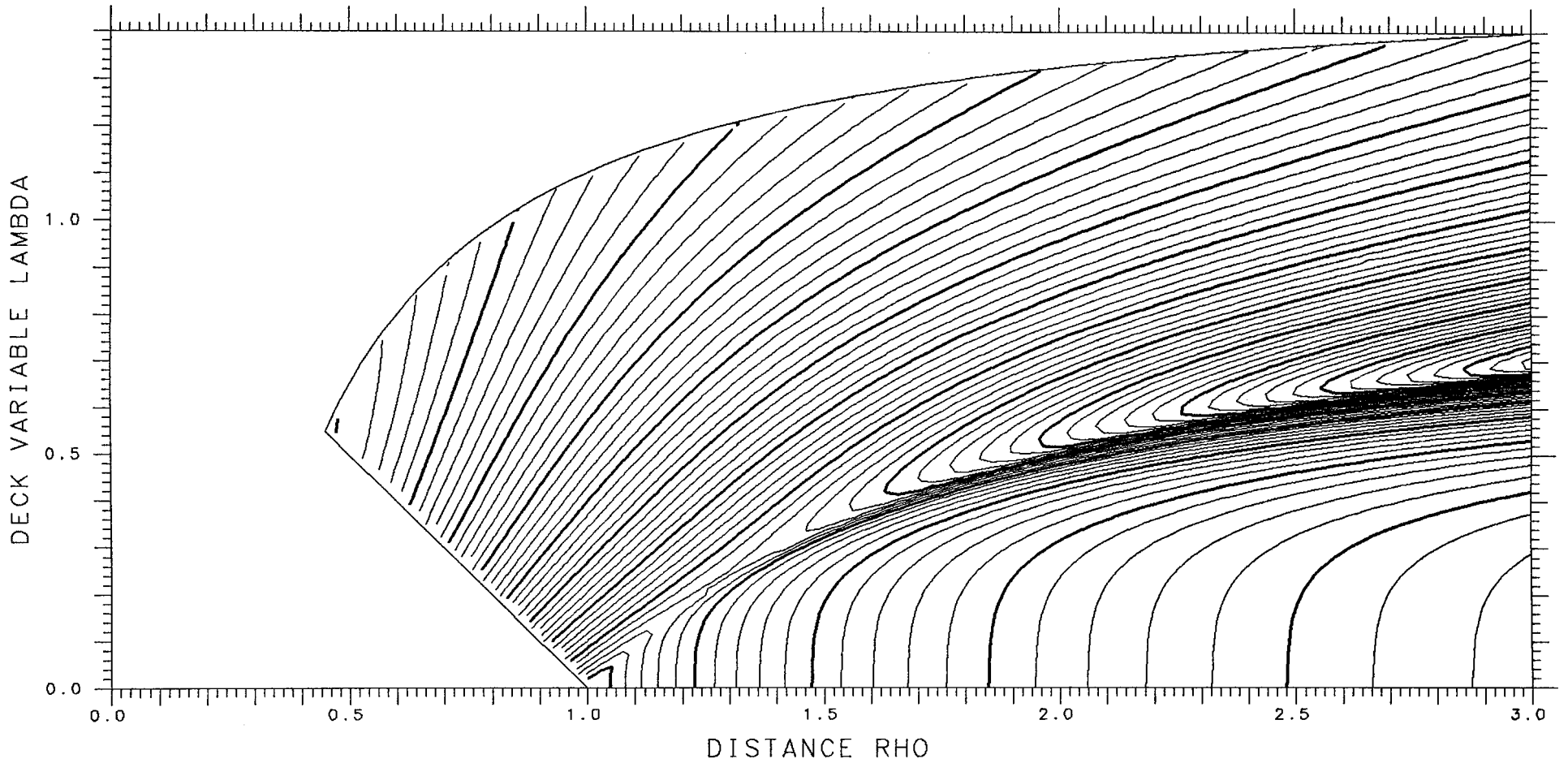

X= .850 ASYMMETRY DELTA= .550 FRACTIONAL= .9761

SPHERES .00318 TANGENT .05479 LENGTH 10.046 ENERGY 668.85 SPACING .002

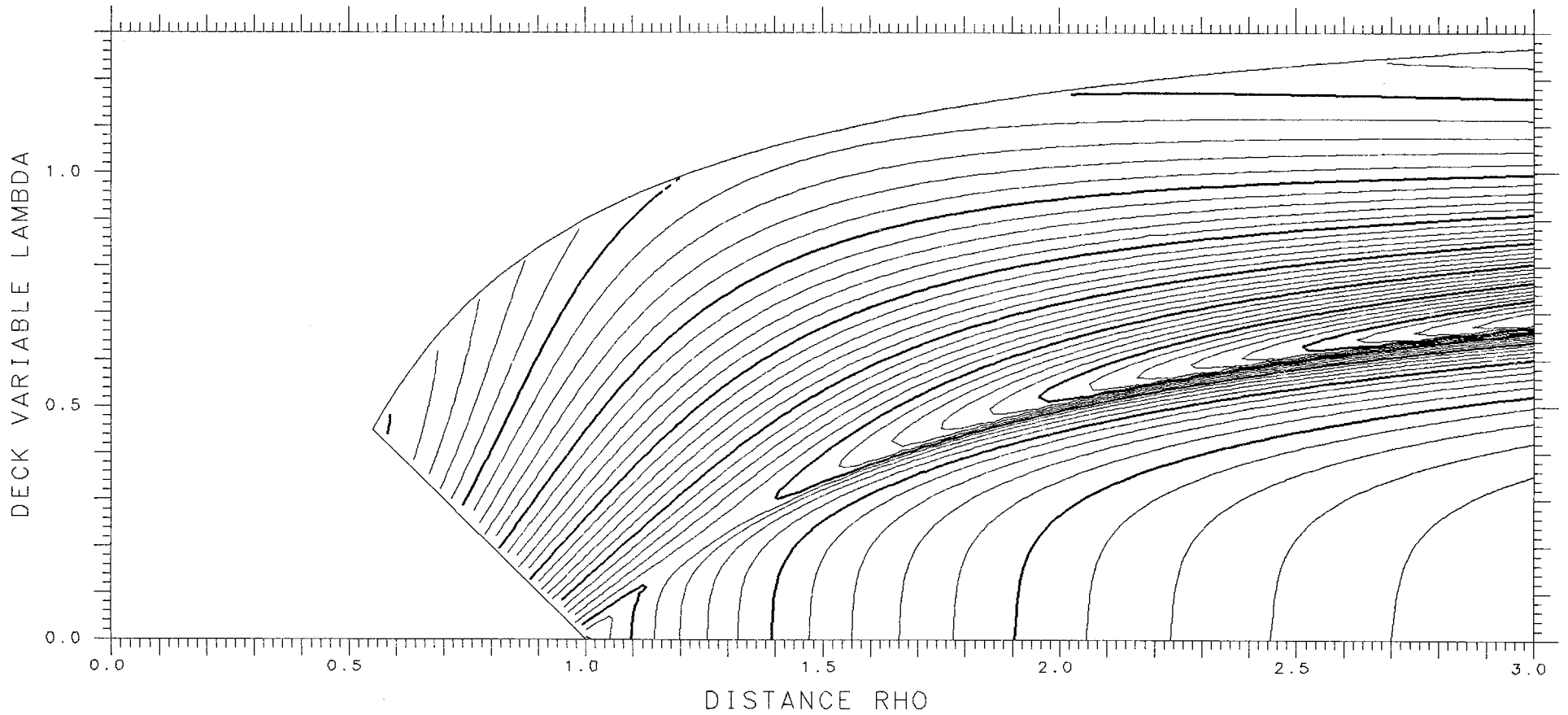

X= .600 ASYMMETRY DELTA= .475 FRACTIONAL= .9569

SPHERES .01536 TANGENT .07716 LENGTH 9.116 ENERGY 522.49 SPACING .002

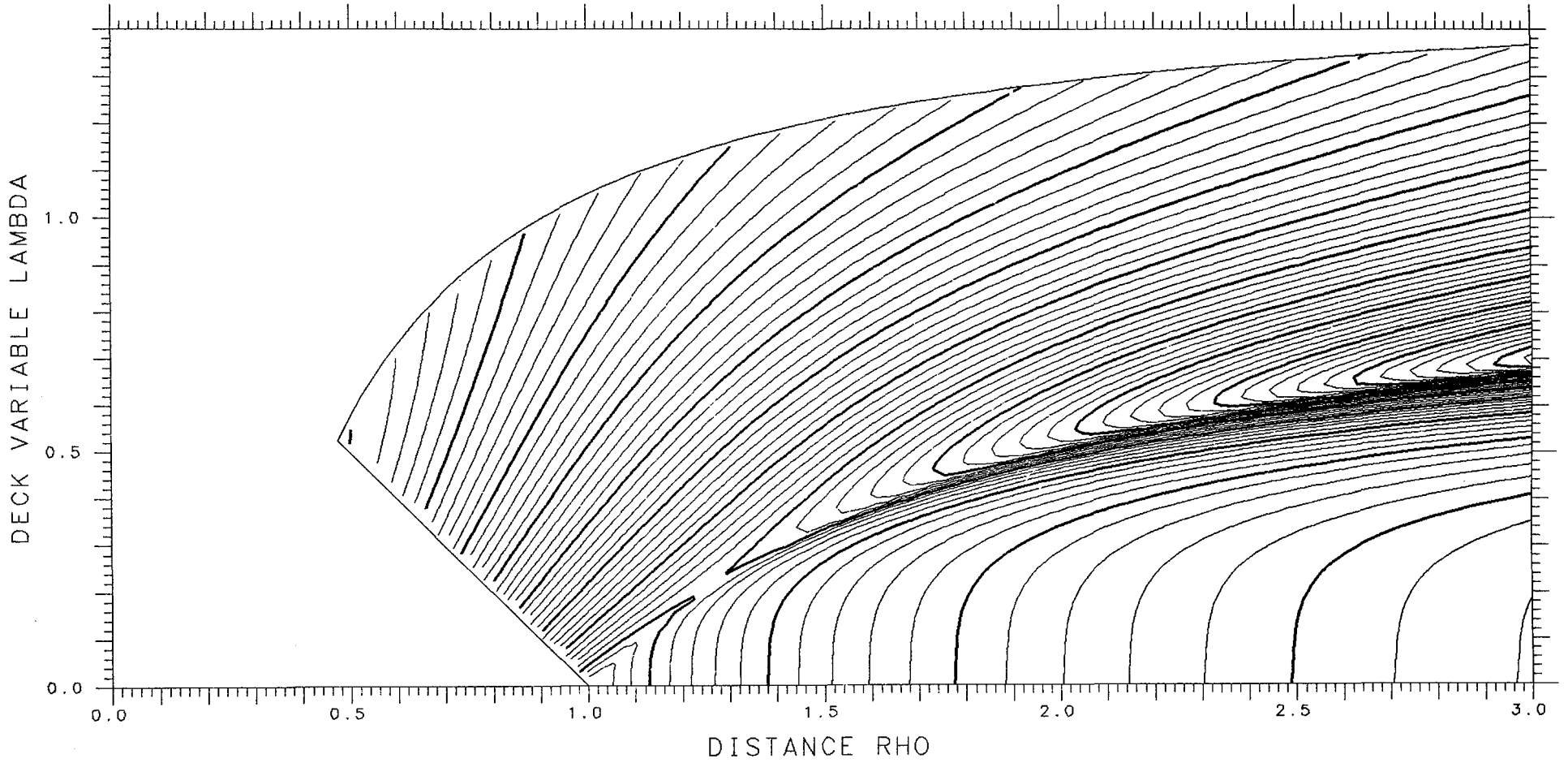

X= .850 ASYMMETRY DELTA= .525 FRACTIONAL= .9707

SPHERES -.00209 TANGENT .06003 LENGTH 10.192 ENERGY 668.85 SPACING .002

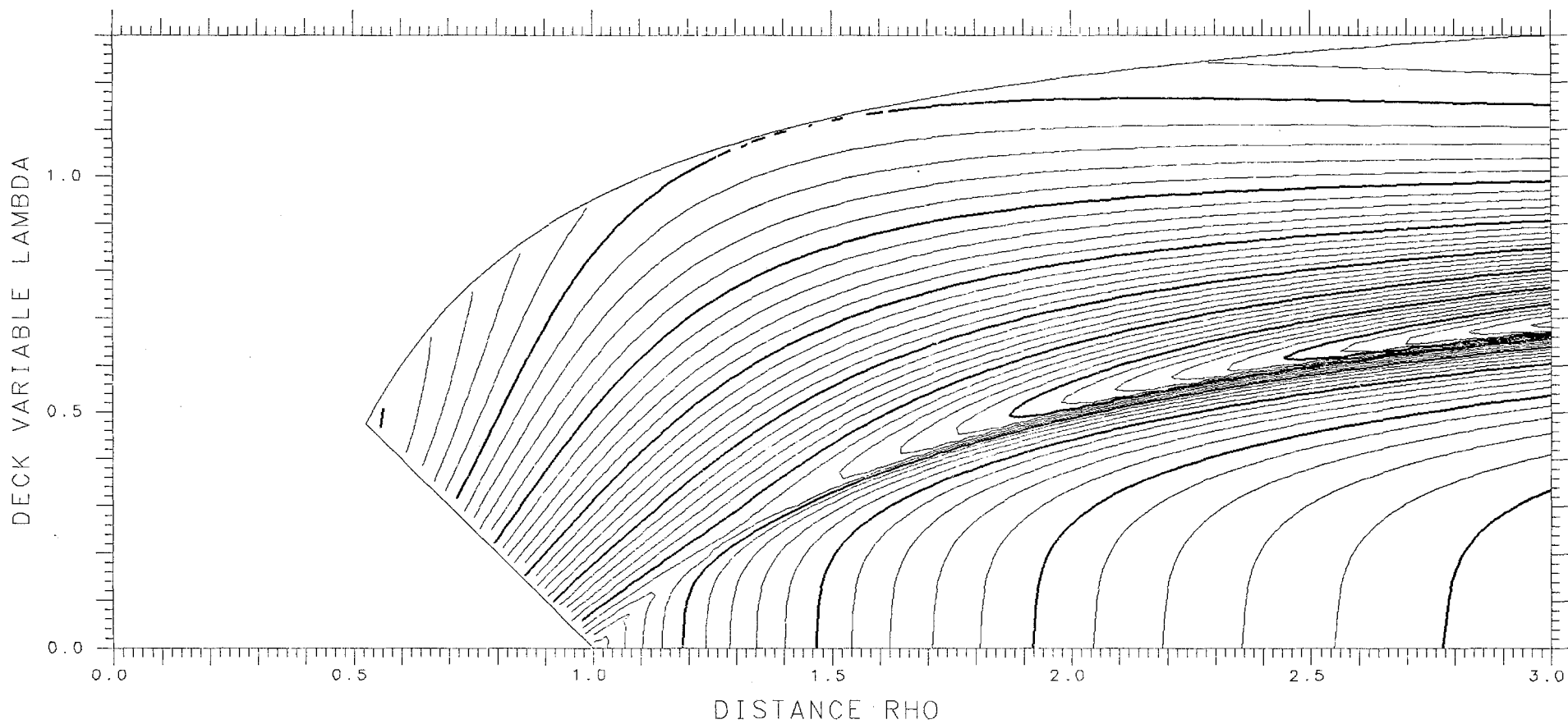

X= .600 ASYMMETRY DELTA= .500 FRACTIONAL= .9643

SPHERES .01857 TANGENT .07086 LENGTH 8.987 ENERGY 522.49 SPACING .002

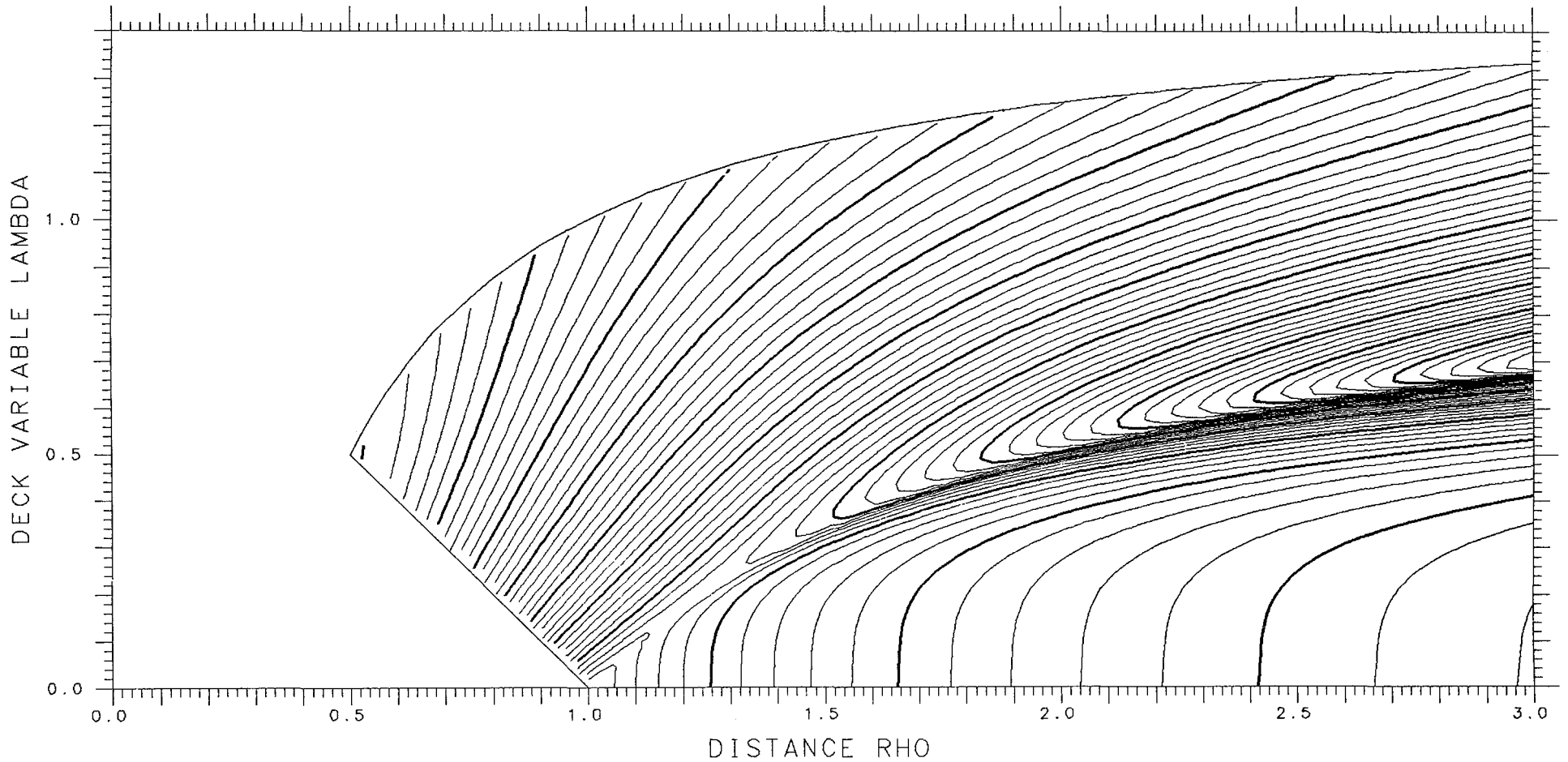

X= .850 ASYMMETRY DELTA= .500 FRACTIONAL= .9643

SPHERES -.00890 TANGENT .06517 LENGTH 10.339 ENERGY 668.85 SPACING .002

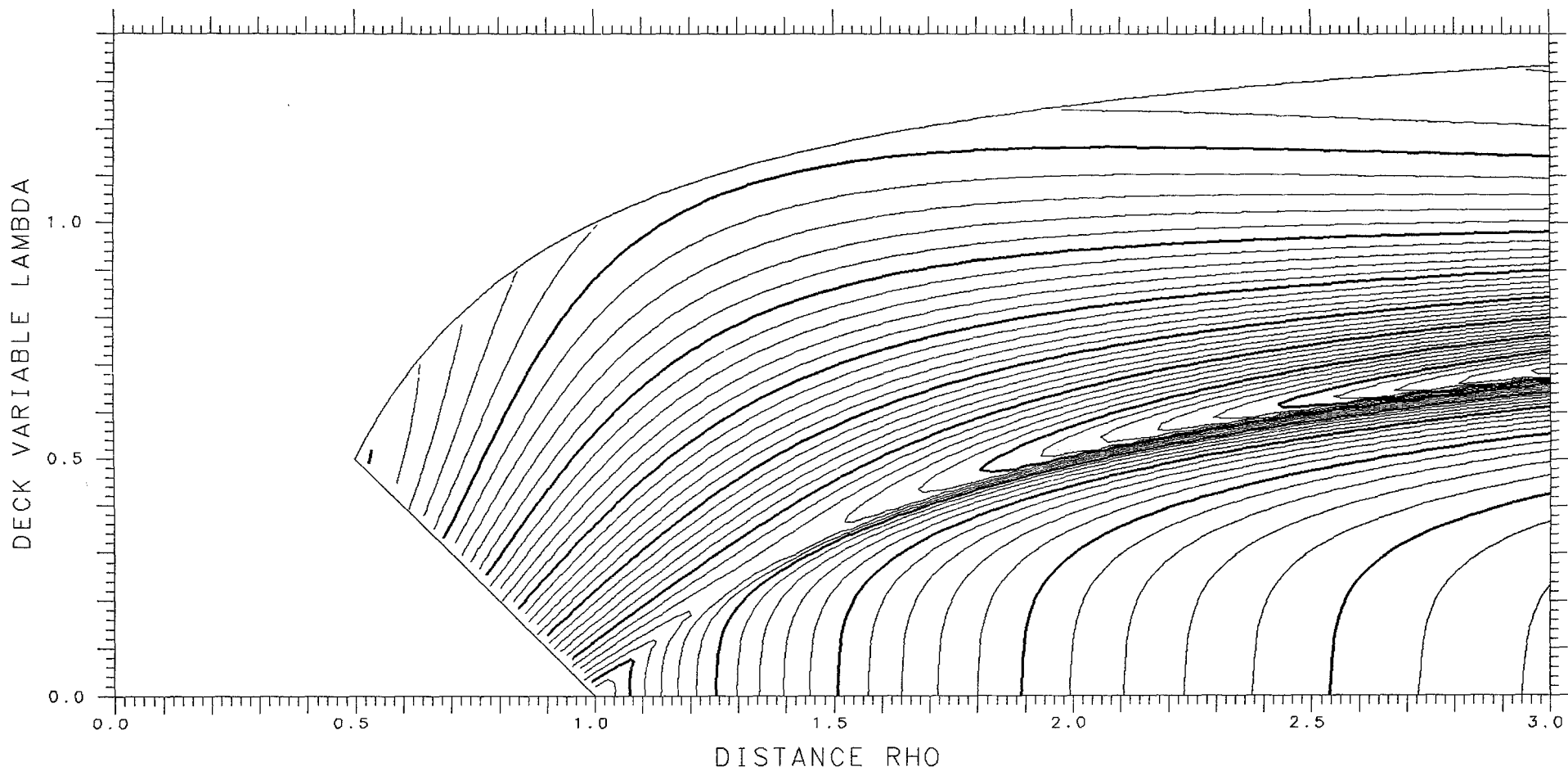

X= .600 ASYMMETRY DELTA= .525 FRACTIONAL= .9707

SPHERES .02072 TANGENT .06457 LENGTH 8.859 ENERGY 522.49 SPACING .002

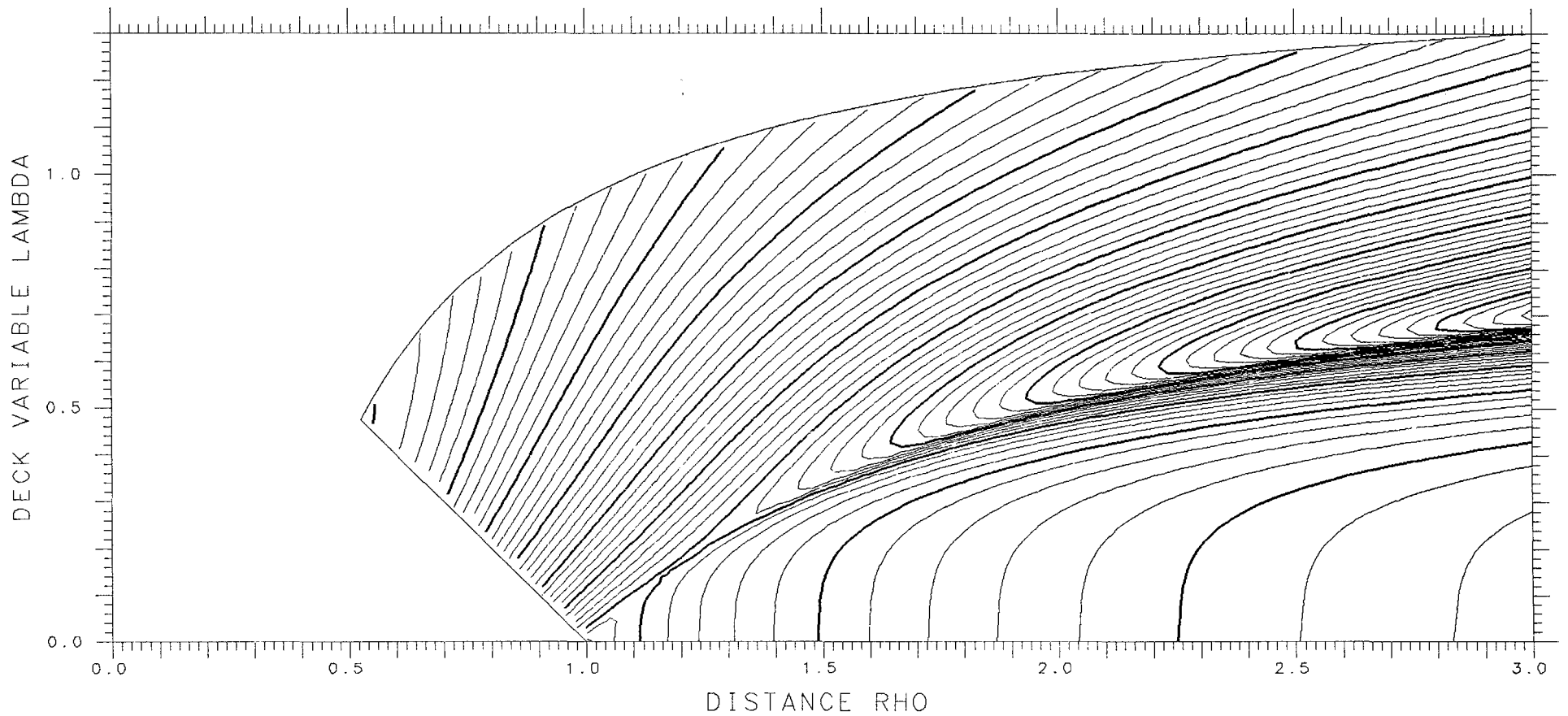

X= .850 ASYMMETRY DELTA= .475 FRACTIONAL= .9569

SPHERES -.01742 TANGENT .07013 LENGTH 10.487 ENERGY 668.85 SPACING .002 SADDLE .05682

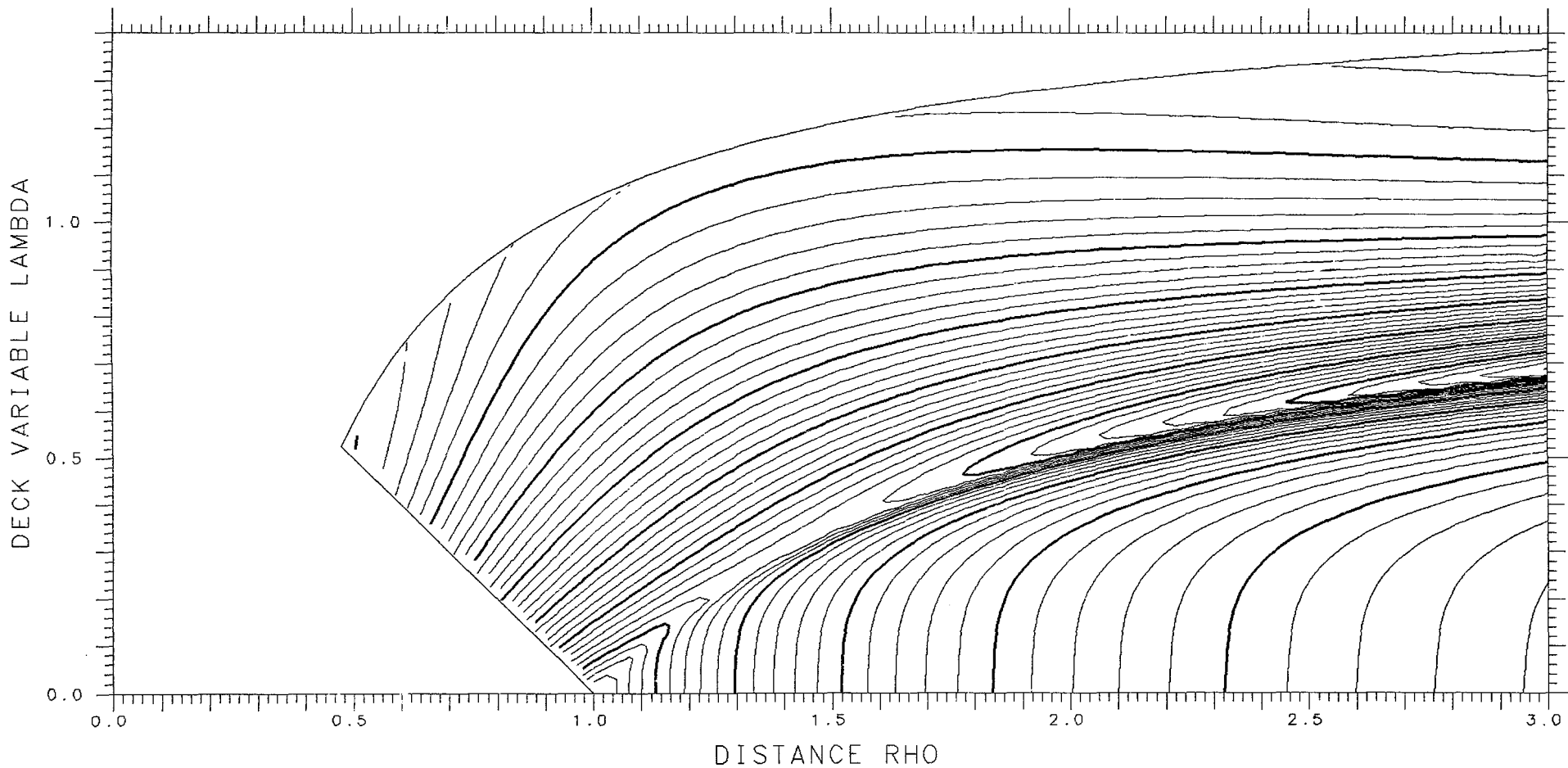

X= .600 ASYMMETRY DELTA= .550 FRACTIONAL= .9761

SPHERES .02194 TANGENT .05837 LENGTH 8.732 ENERGY 522.49 SPACING .002

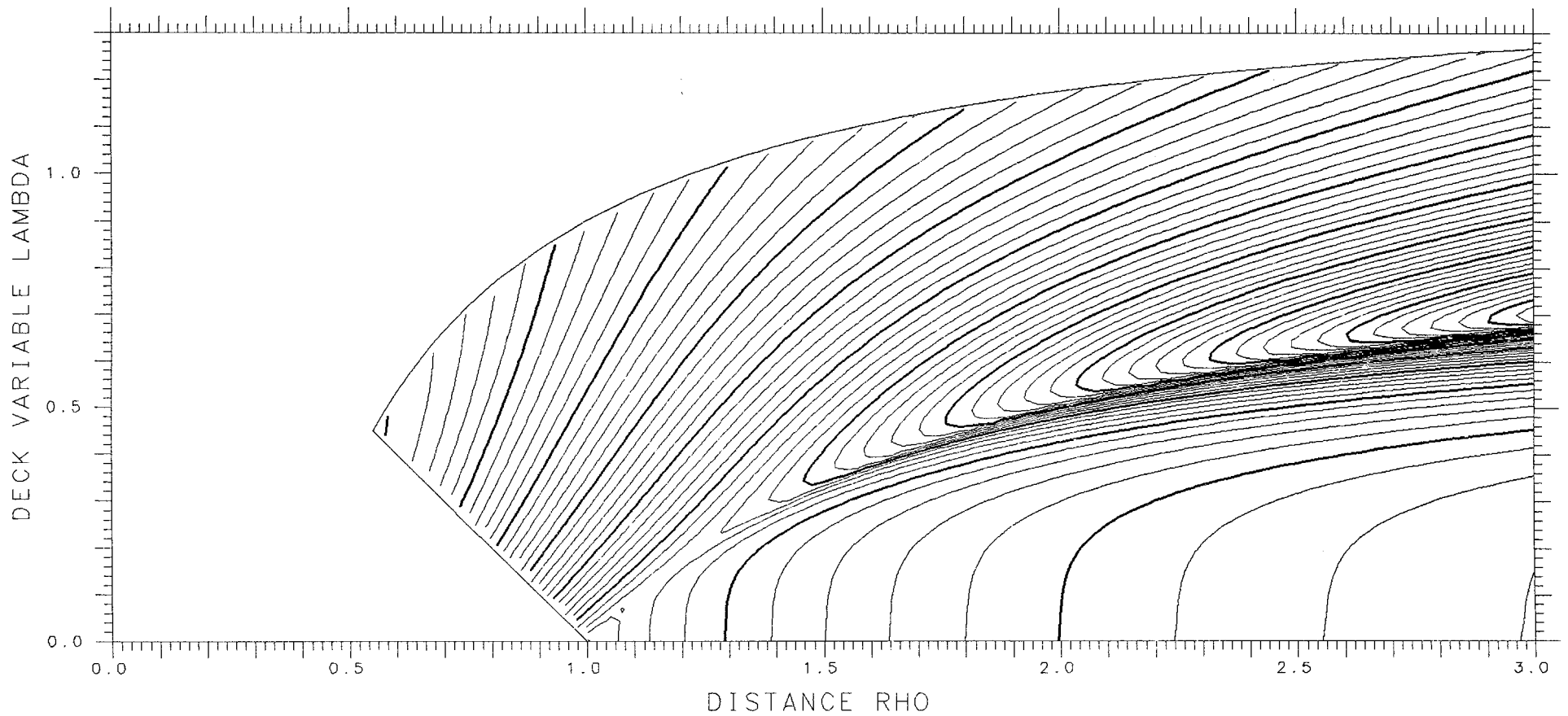

X= .850 ASYMMETRY DELTA= .450 FRACTIONAL= .9483

SPHERES -.02780 TANGENT .07480 LENGTH 10.636 ENERGY 668.85 SPACING .002 SADDLE .05772

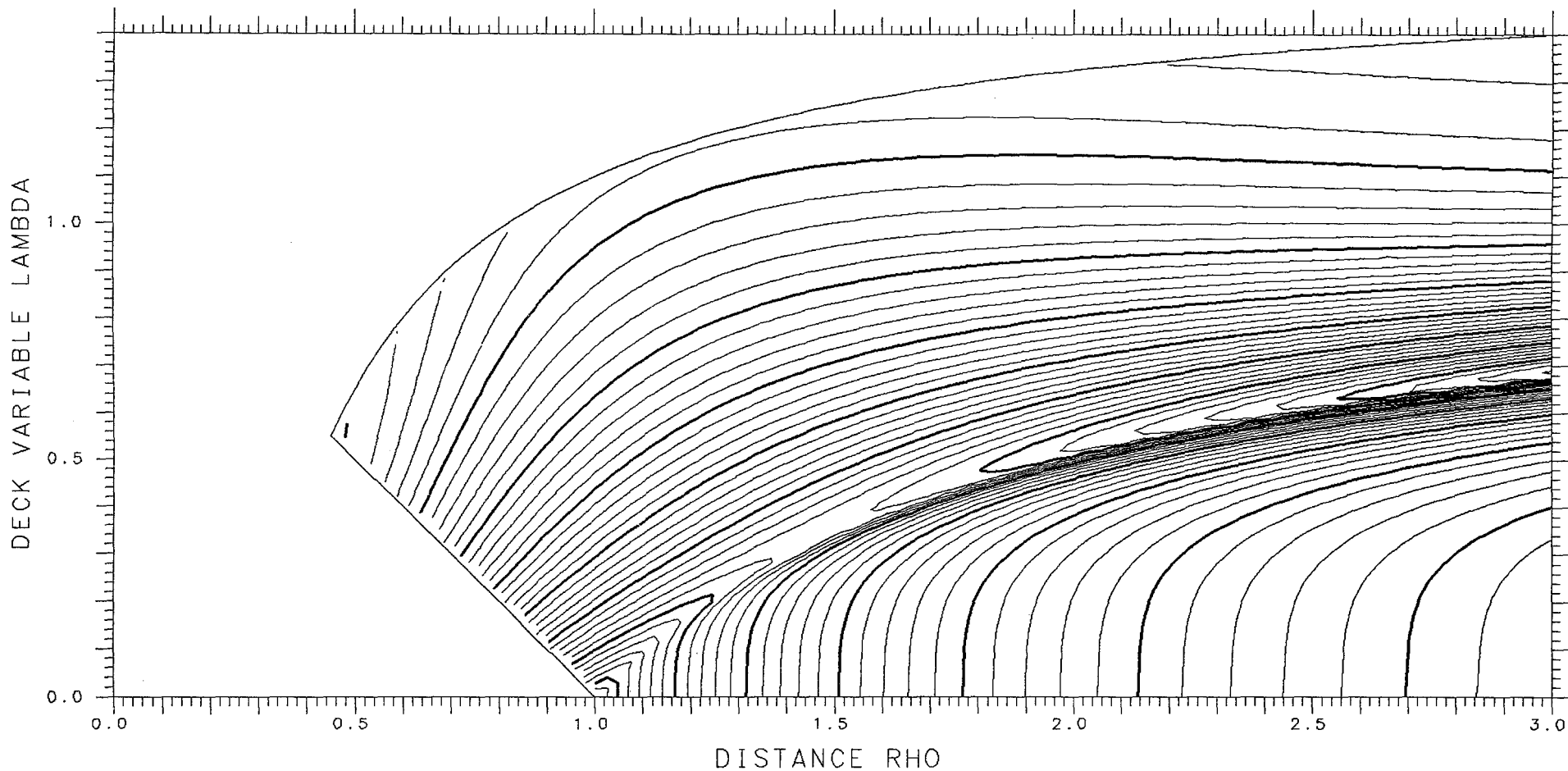

X= .625

ASYMMETRY DELTA=0.

FRACTIONAL= .5000

SPHERES -.20263

TANGENT .12548

LENGTH 11.010

ENERGY 538.09

SPACING .002

SADDLE .04983

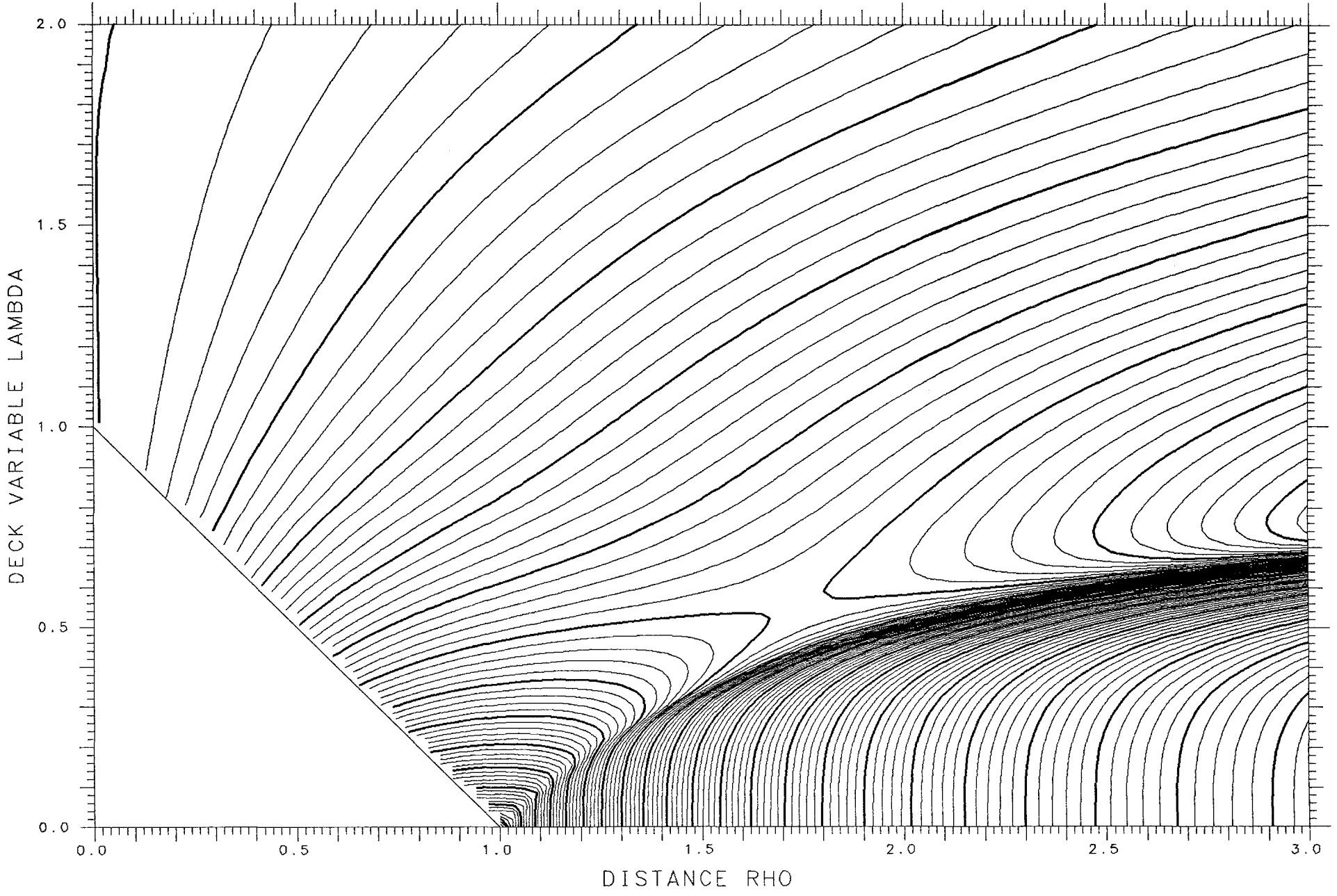

X= .850 ASYMMETRY DELTA= .425 FRACTIONAL= .9384

SPHERES -.04018 TANGENT .07911 LENGTH 10.785 ENERGY 668.85 SPACING .002 SADDLE .05747

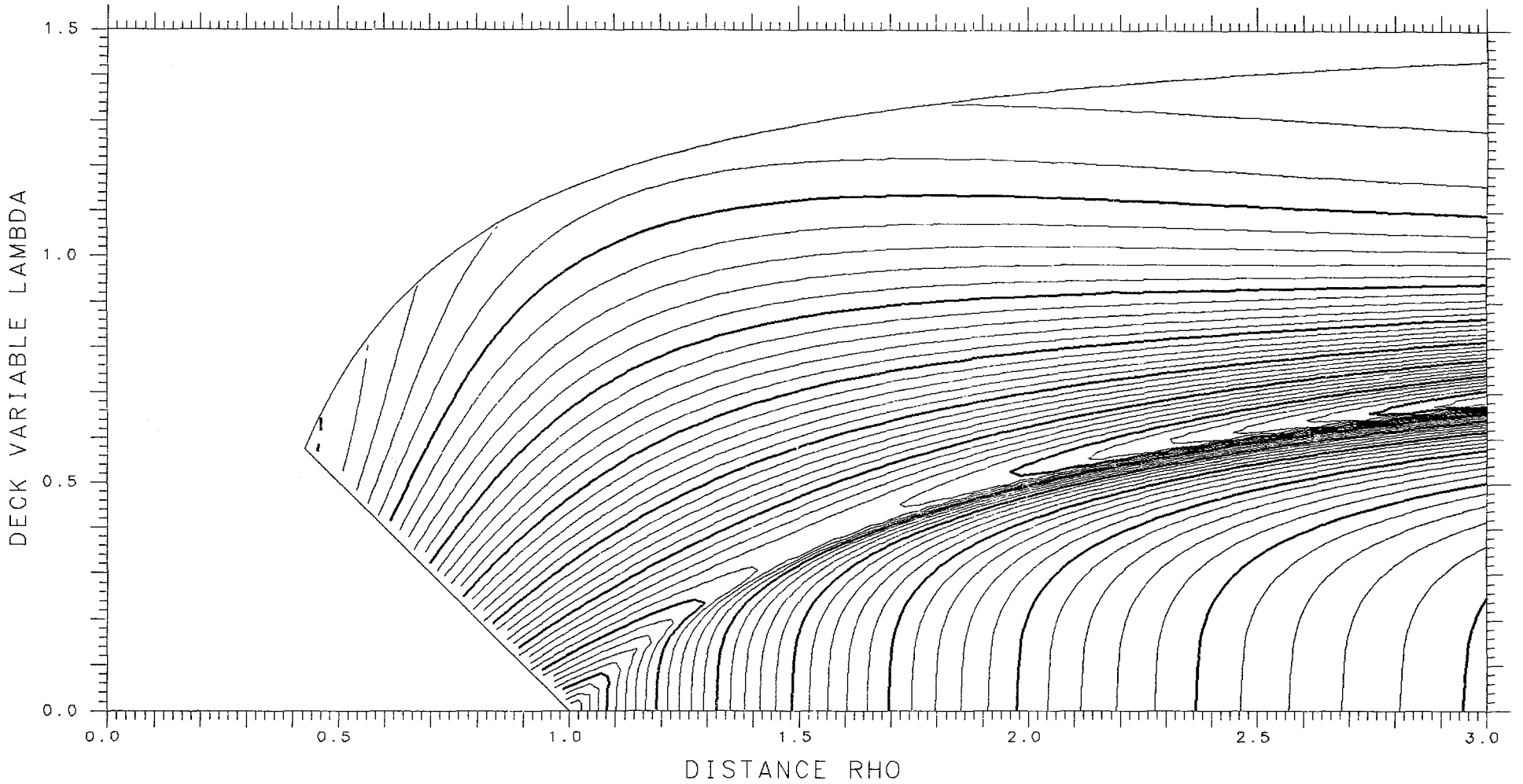

X= .625 ASYMMETRY DELTA= .025 FRACTIONAL= .5374

SPHERES -.20096 TANGENT .12551 LENGTH 11.003 ENERGY 538.09 SPACING .002 SADDLE .05022

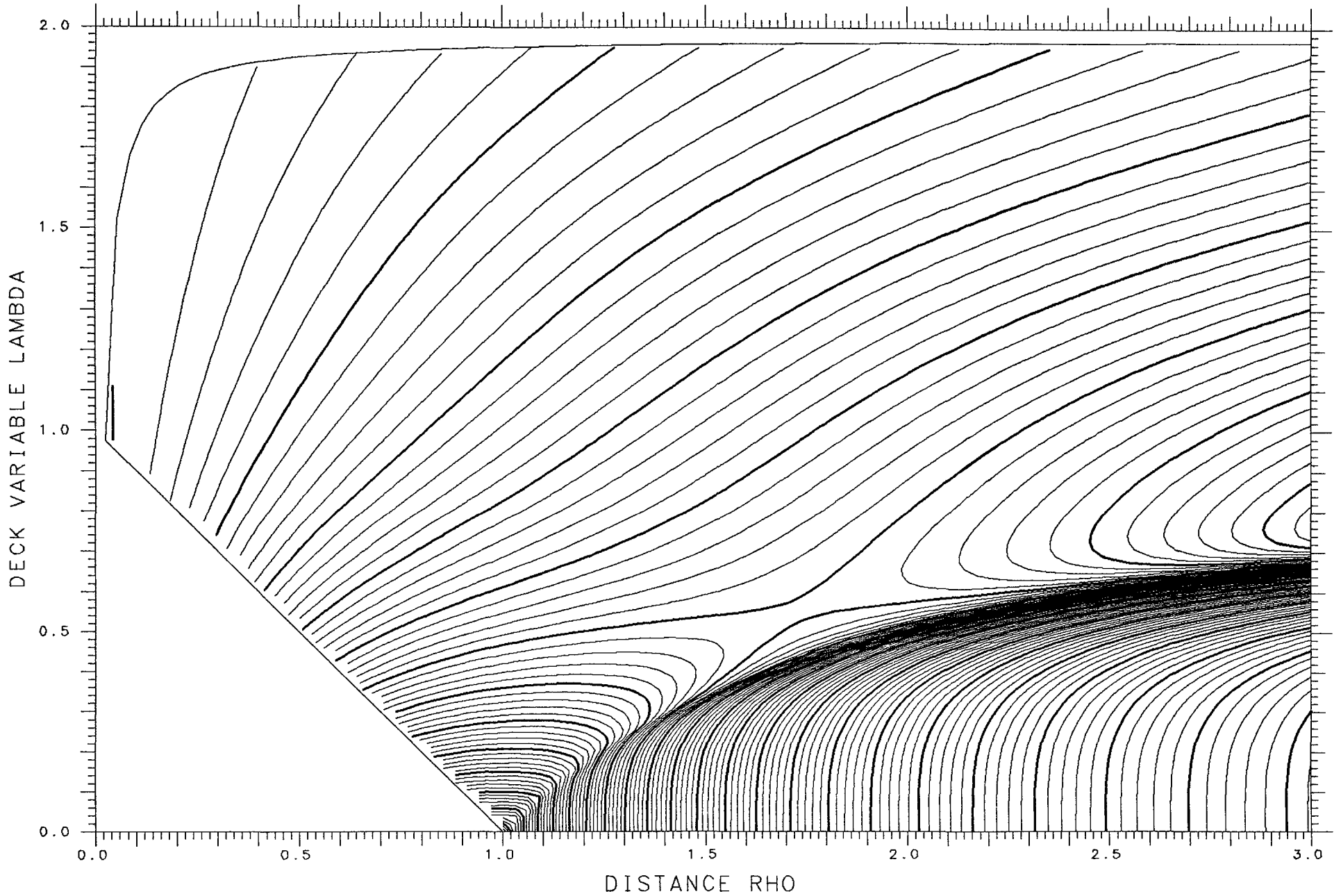

X= .850 ASYMMETRY DELTA= .400 FRACTIONAL= .9270

SPHERES -.05466 TANGENT .08294 LENGTH 10.933 ENERGY 668.85 SPACING .002 SADDLE .05591

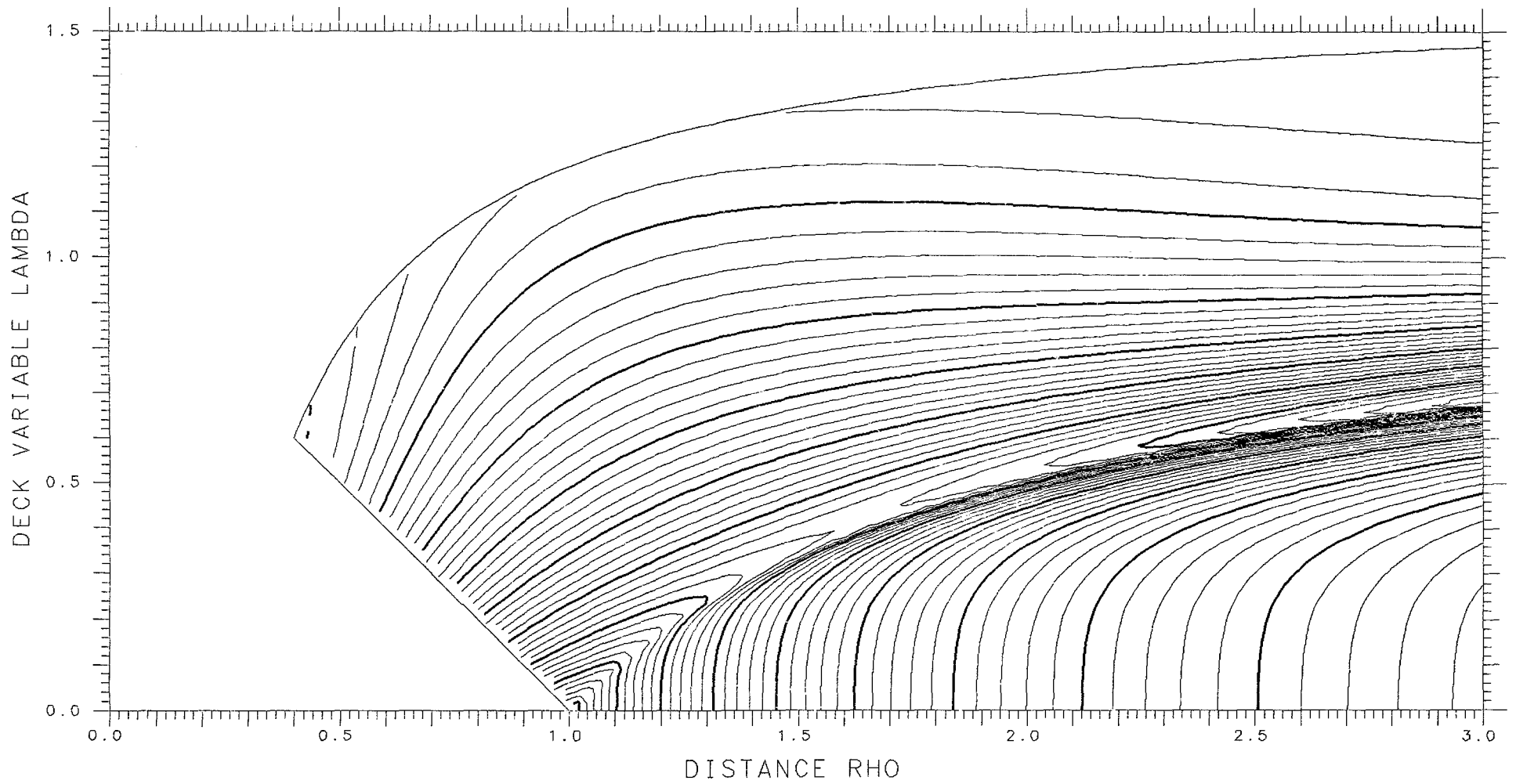

X= .625

ASYMMETRY DELTA= .050

FRACTIONAL= .5745

SPHERES -.19603

TANGENT .12559

LENGTH 10.982

ENERGY 538.09

SPACING .002

SADDLE .05138

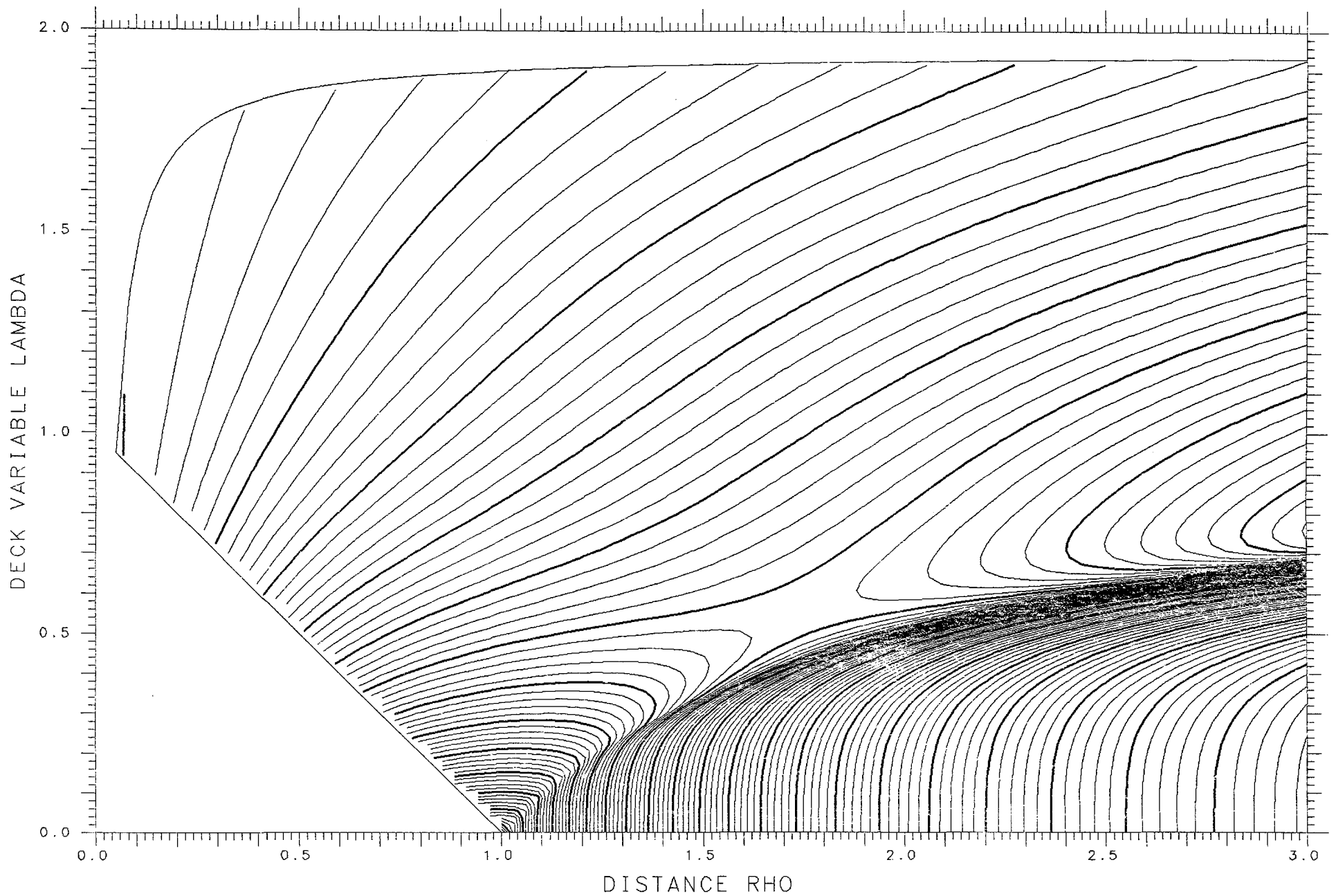

X= .850 ASYMMETRY DELTA= .375 FRACTIONAL= .9141

SPHERES -.07129 TANGENT .08623 LENGTH 11.080 ENERGY 668.85 SPACING .002 SADDLE .05291

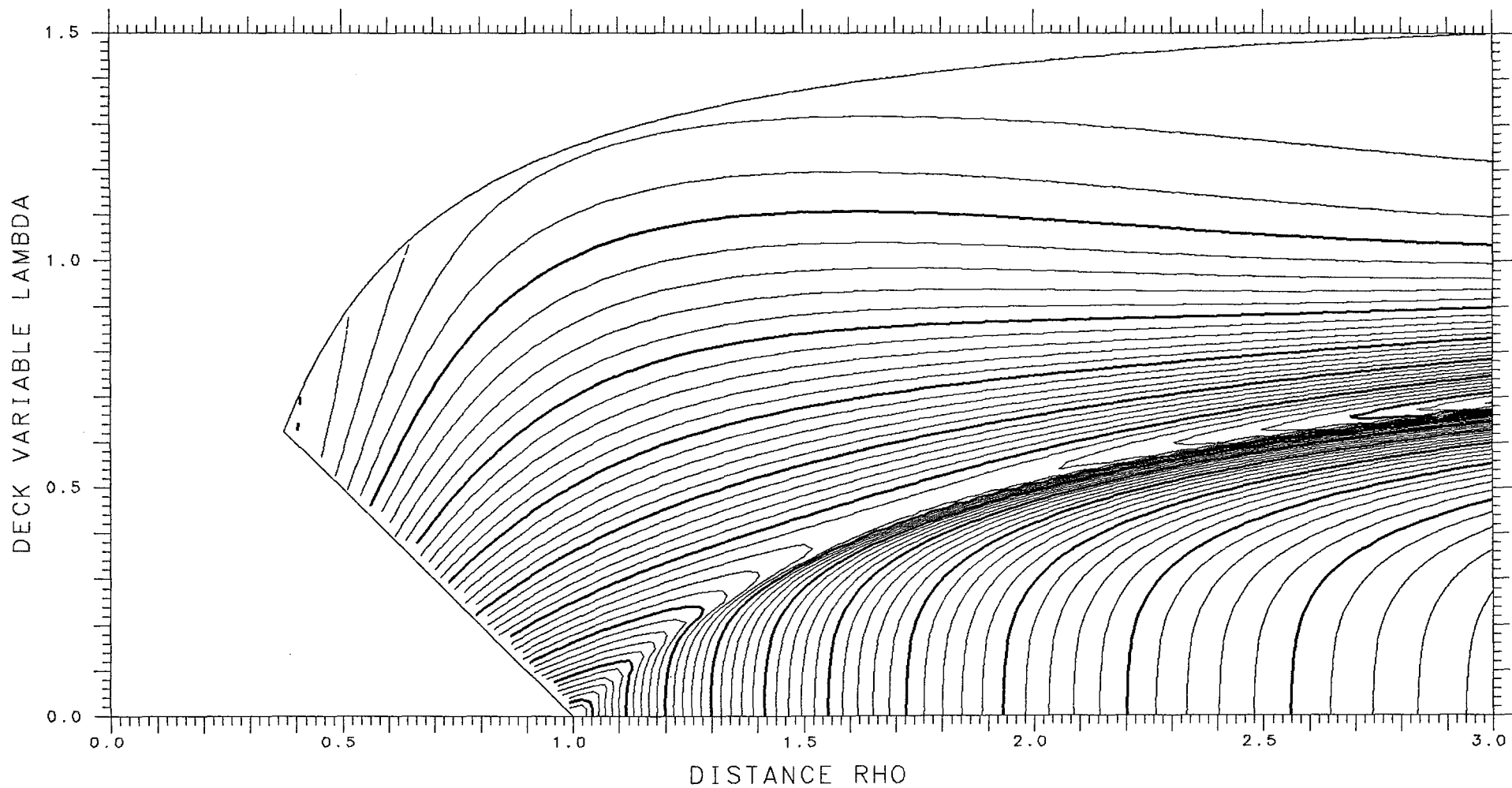

X= .625 ASYMMETRY DELTA= .075 FRACTIONAL= .6108

SPHERES -.18806 TANGENT .12567 LENGTH 10.949 ENERGY 538.09 SPACING .002 SADDLE .05328

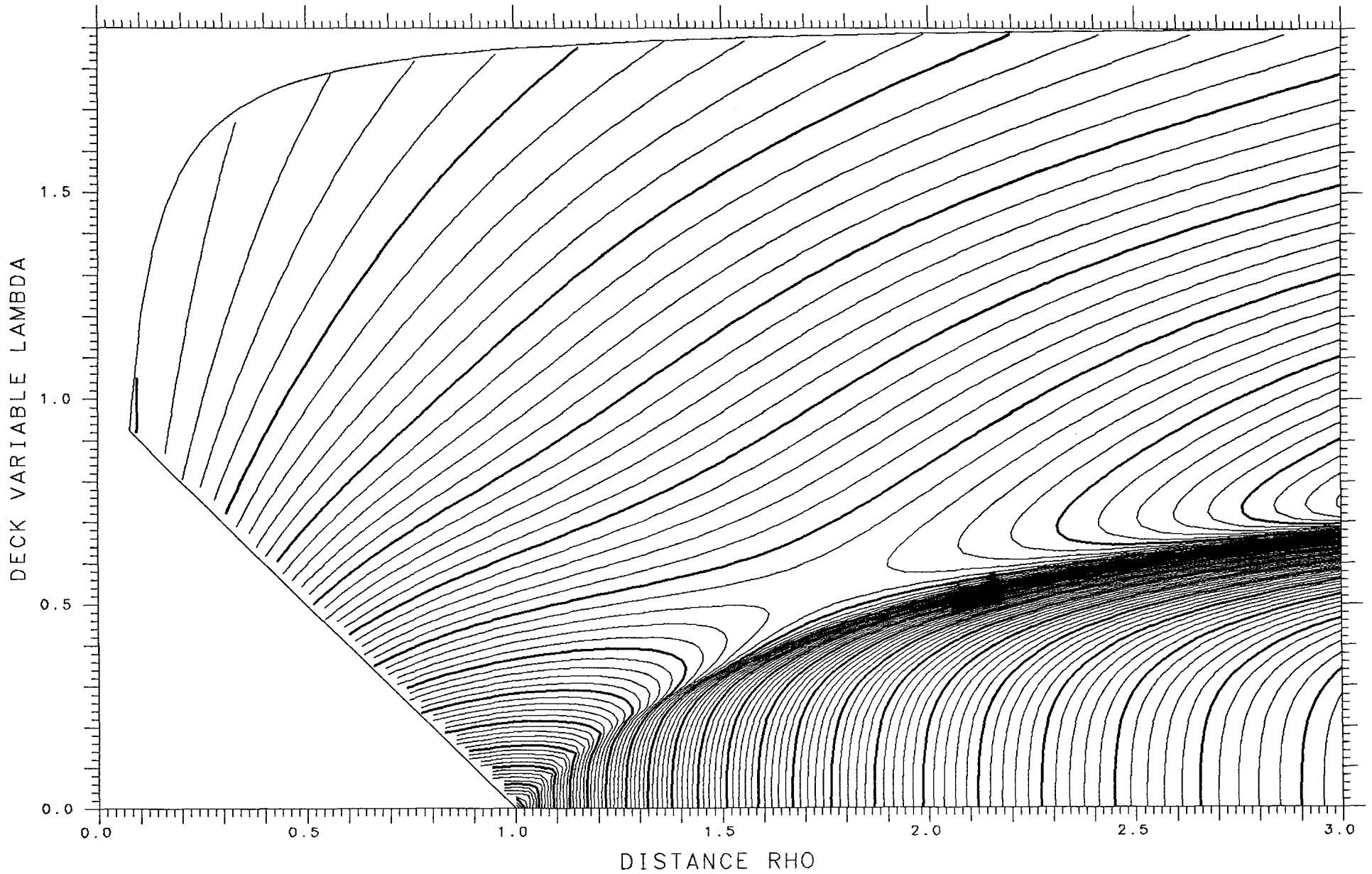

X= .850 ASYMMETRY DELTA= .350 FRACTIONAL= .8996

SPHERES -.09007 TANGENT .08889 LENGTH 11.225 ENERGY 668.85 SPACING .002 SADDLE .04838

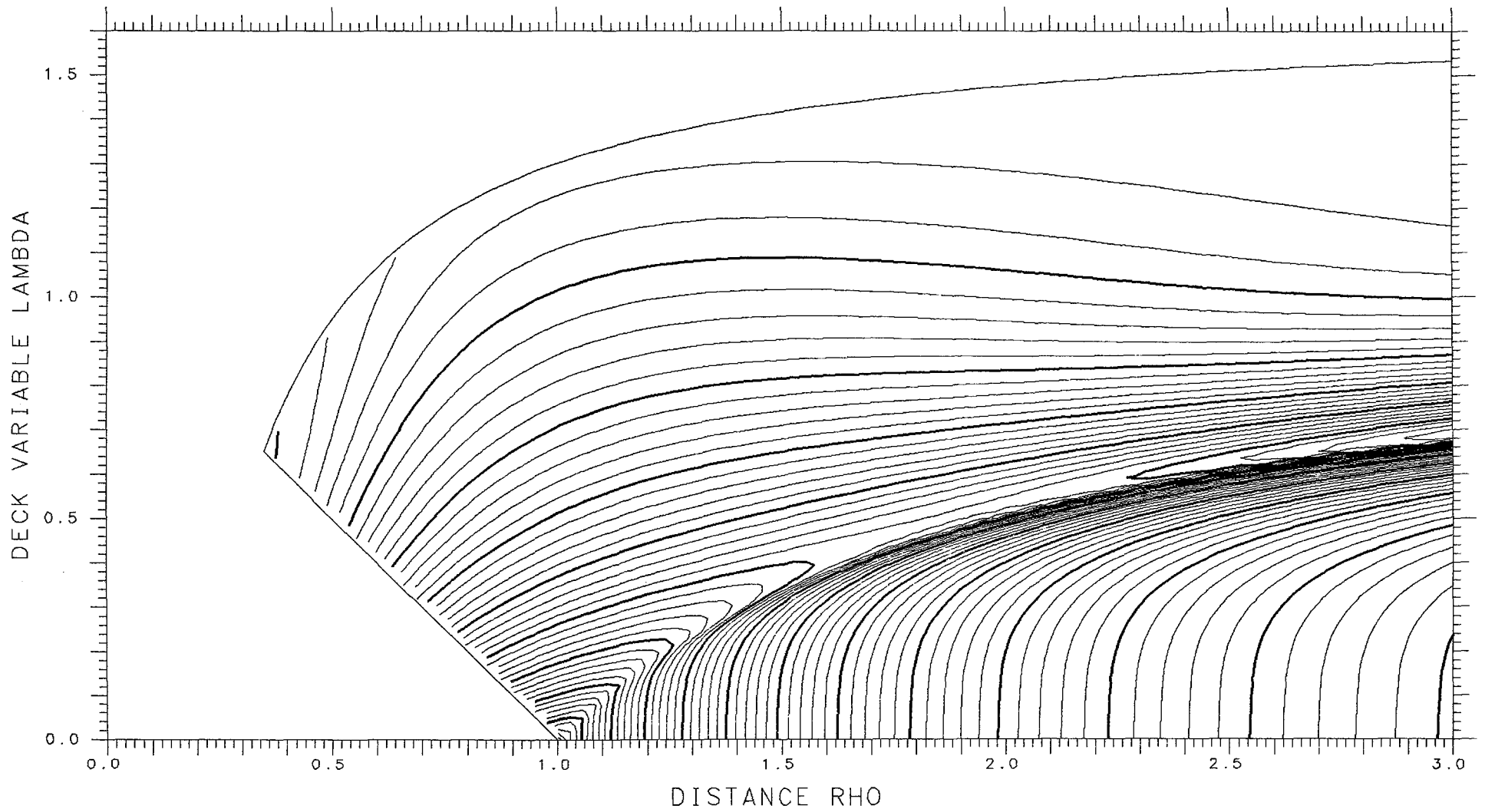

X= .625

ASYMMETRY DELTA= .100

FRACTIONAL= .6461

SPHERES -.17738

TANGENT .12568

LENGTH 10.902

ENERGY 538.09

SPACING .002

SADDLE .05587

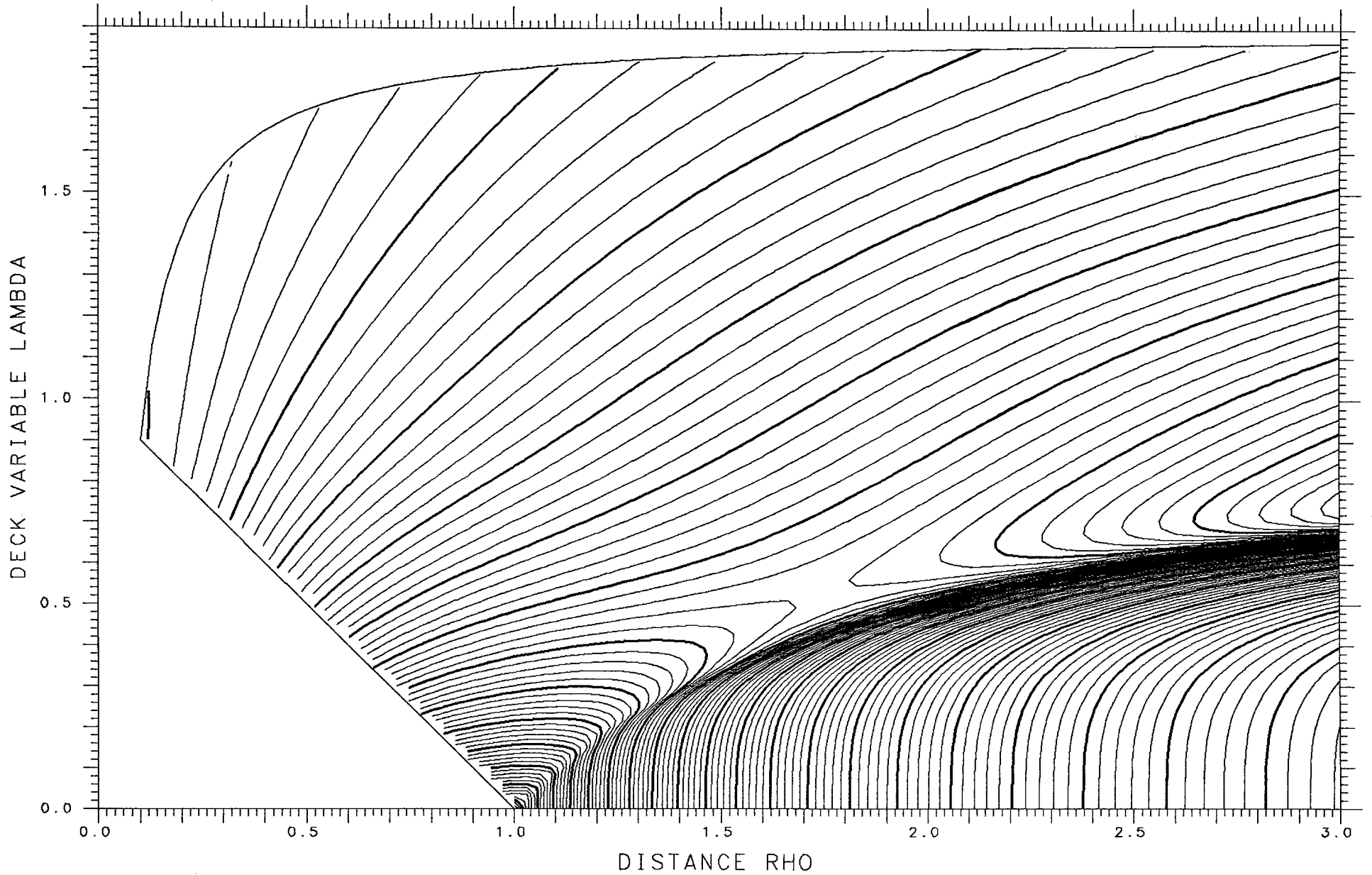

X= .850 ASYMMETRY DELTA= .325 FRACTIONAL= .8832

SPHERES -.11092 TANGENT .09086 LENGTH 11.367 ENERGY 668.85 SPACING .002 SADDLE .04234

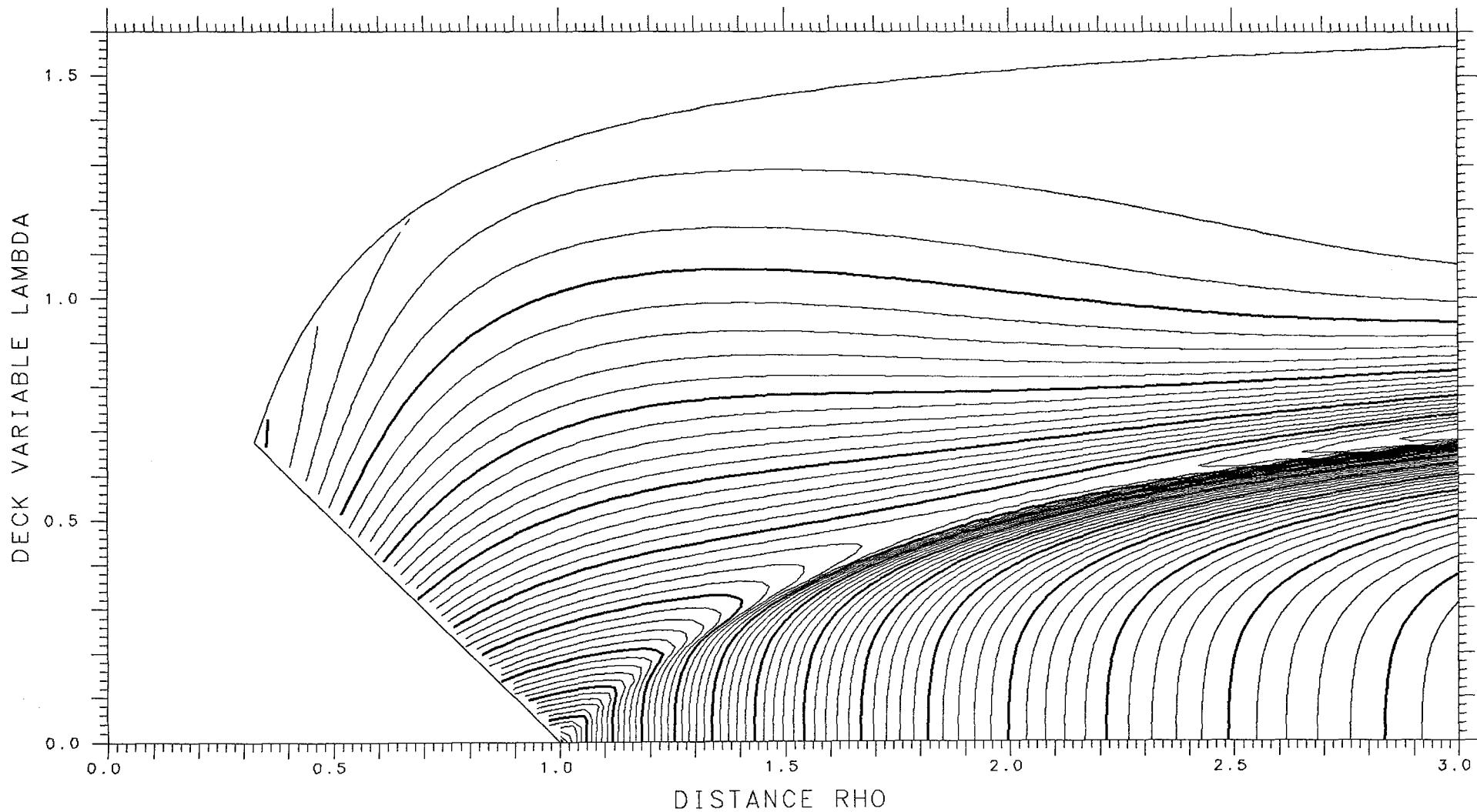

X= .625 ASYMMETRY DELTA= .125 FRACTIONAL= .6800

SPHERES -.16443 TANGENT .12553 LENGTH 10.843 ENERGY 538.09 SPACING .002 SADDLE .05906

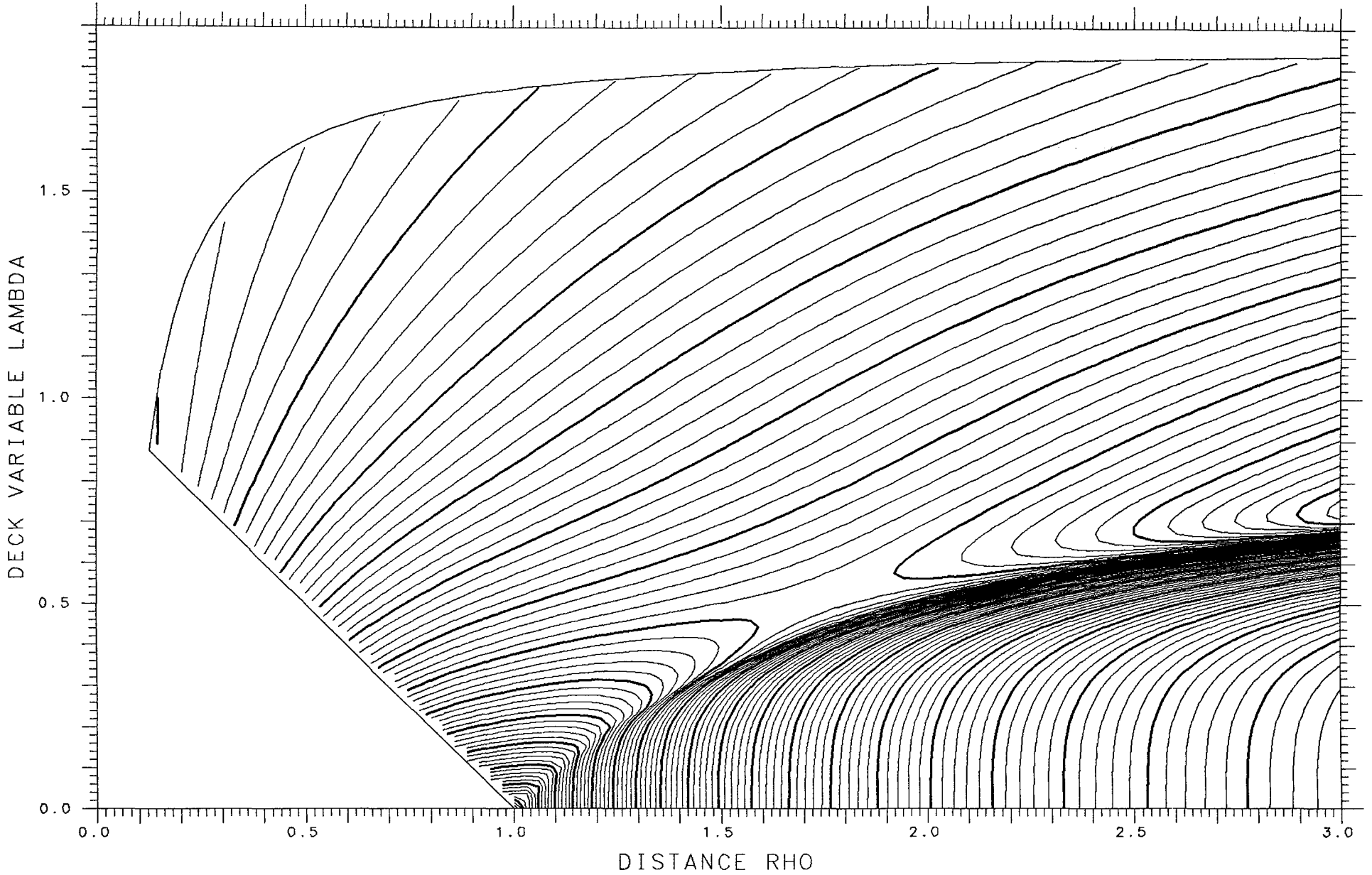

X= .850 ASYMMETRY DELTA= .300 FRACTIONAL= .8650

SPHERES -.13367 TANGENT .09211 LENGTH 11.505 ENERGY 668.85 SPACING .002 SADDLE .03490

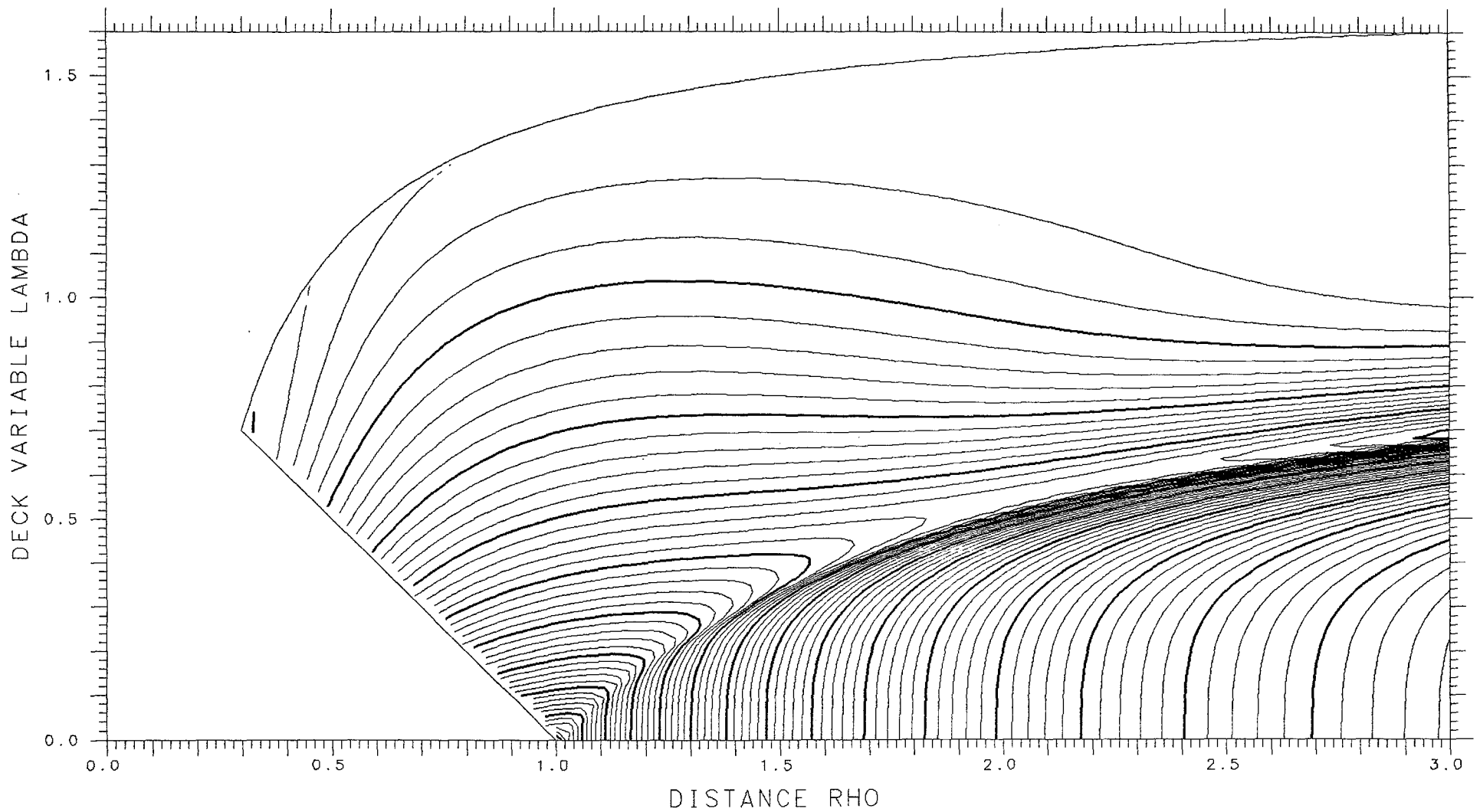

X= .625 ASYMMETRY DELTA= .150 FRACTIONAL= .7124

SPHERES -.14971 TANGENT .12513 LENGTH 10.773 ENERGY 538.09 SPACING .002 SADDLE .06269

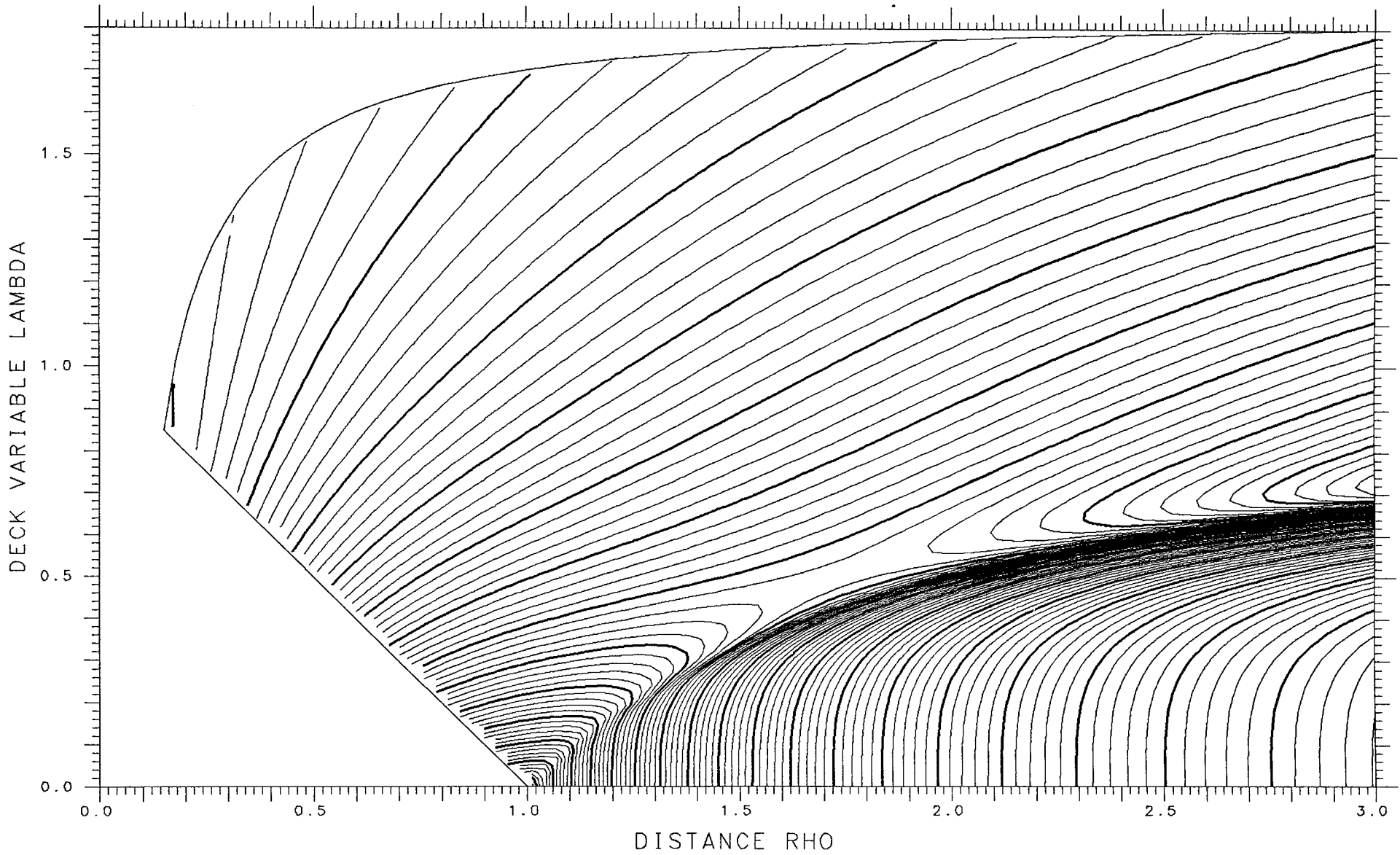

X= .850 ASYMMETRY DELTA= .275 FRACTIONAL= .8447

SPHERES -.15804 TANGENT .09262 LENGTH 11.638 ENERGY 668.85 SPACING .002 SADDLE .02625

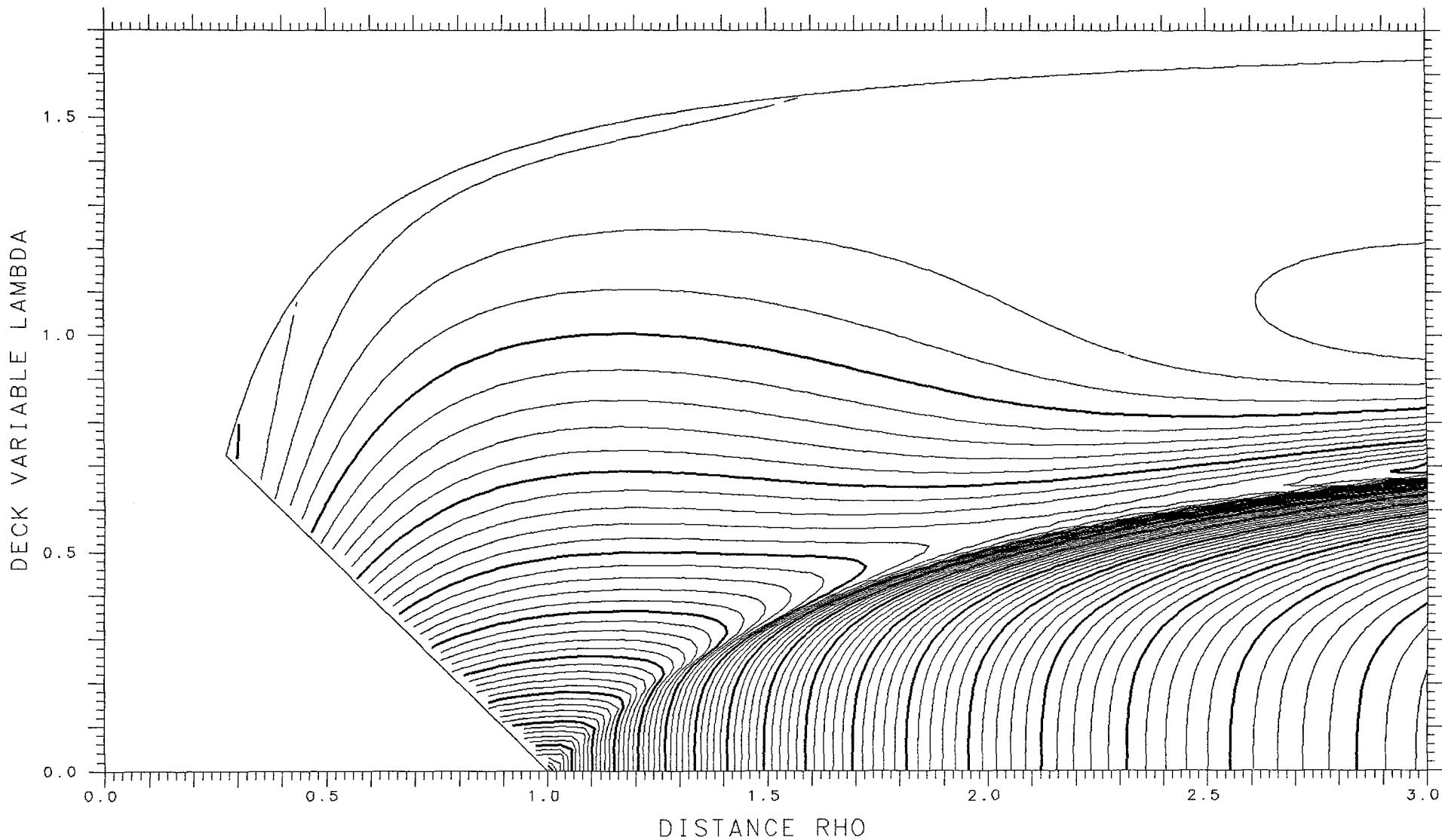

X= .625 ASYMMETRY DELTA= .175 FRACTIONAL= .7429

SPHERES -.13377 TANGENT .12438 LENGTH 10.692 ENERGY 538.09 SPACING .002 SADDLE .06653

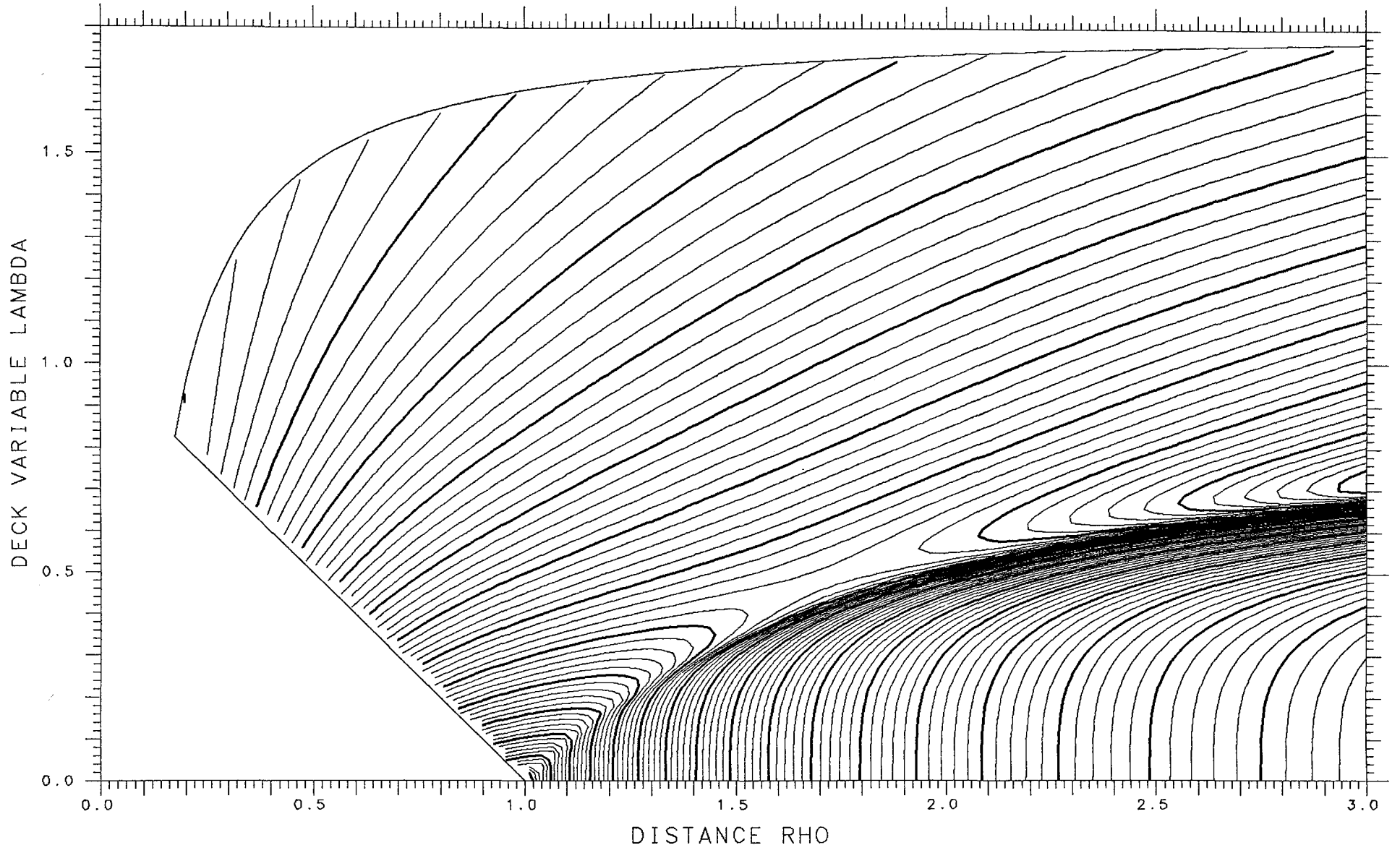

X= .850 ASYMMETRY DELTA= .250 FRACTIONAL= .8224

SPHERES -.18368 TANGENT .09242 LENGTH 11.766 ENERGY 668.85 SPACING .002 SADDLE .01668

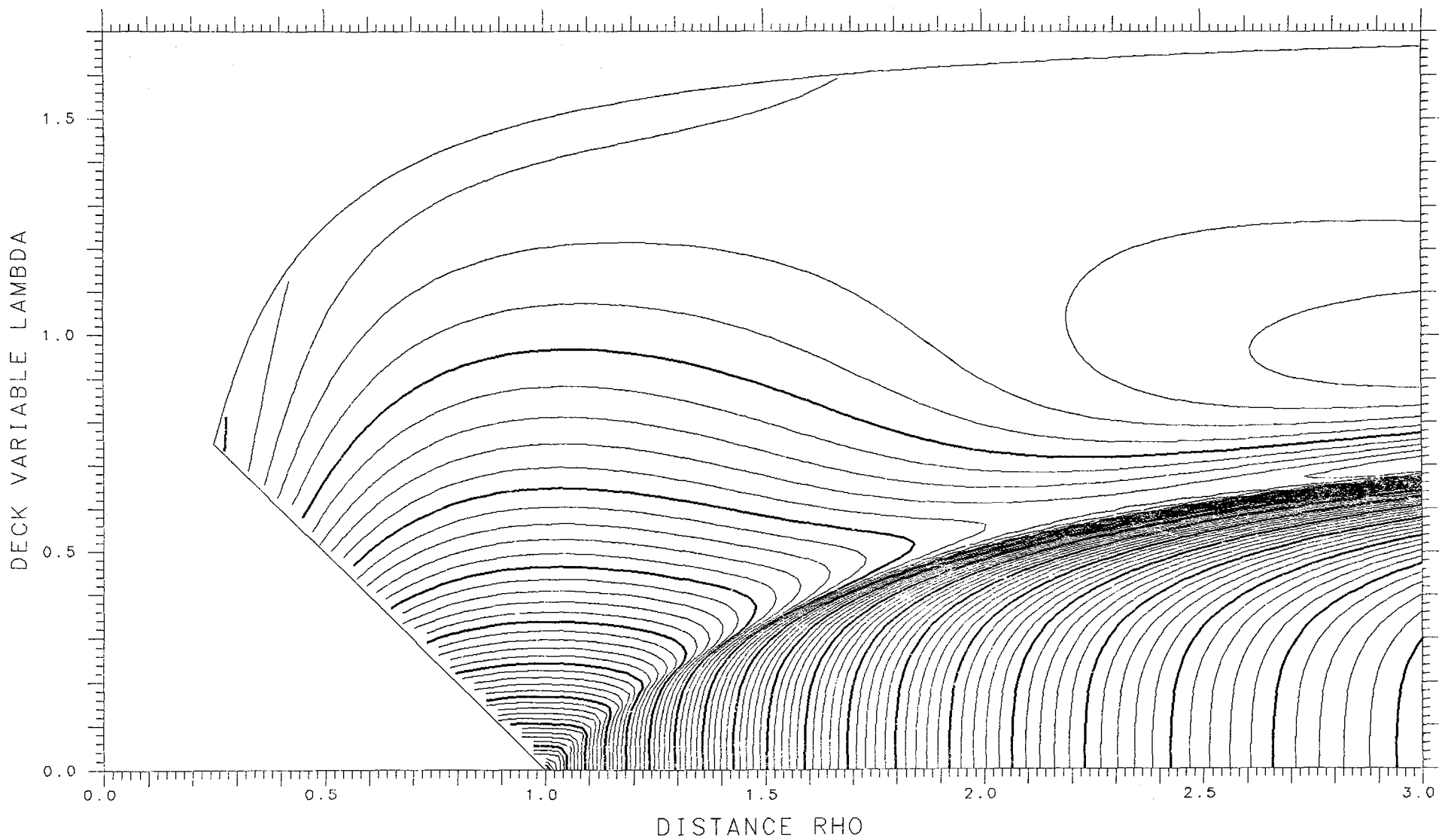

X= .625 ASYMMETRY DELTA= .200 FRACTIONAL= .7714

SPHERES -.11713 TANGENT .12319 LENGTH 10.602 ENERGY 538.09 SPACING .002 SADDLE .07037

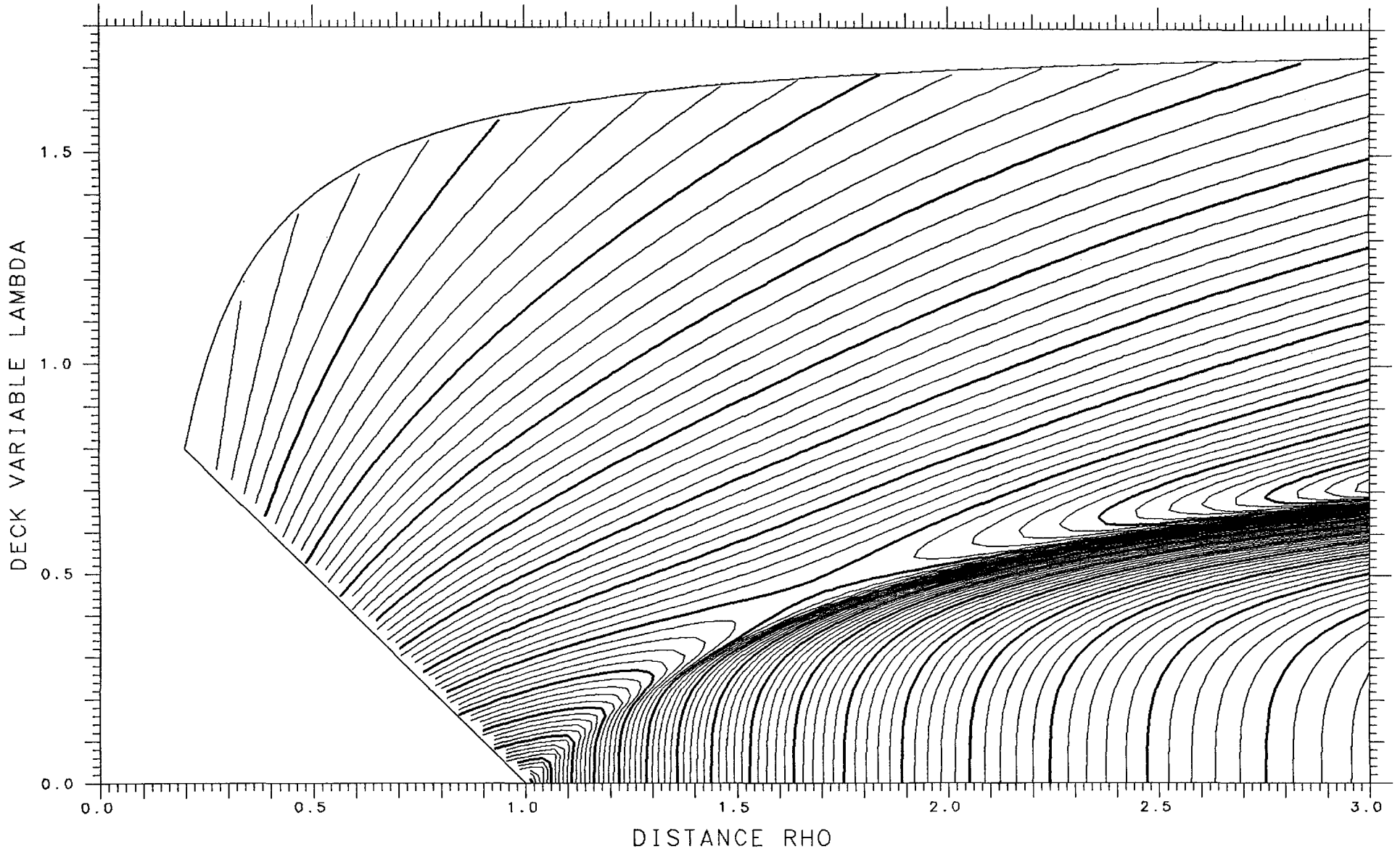

X= .850 ASYMMETRY DELTA= .225 FRACTIONAL= .7979

SPHERES -.21009 TANGENT .09157 LENGTH 11.886 ENERGY 668.85 SPACING .002 SADDLE .00654

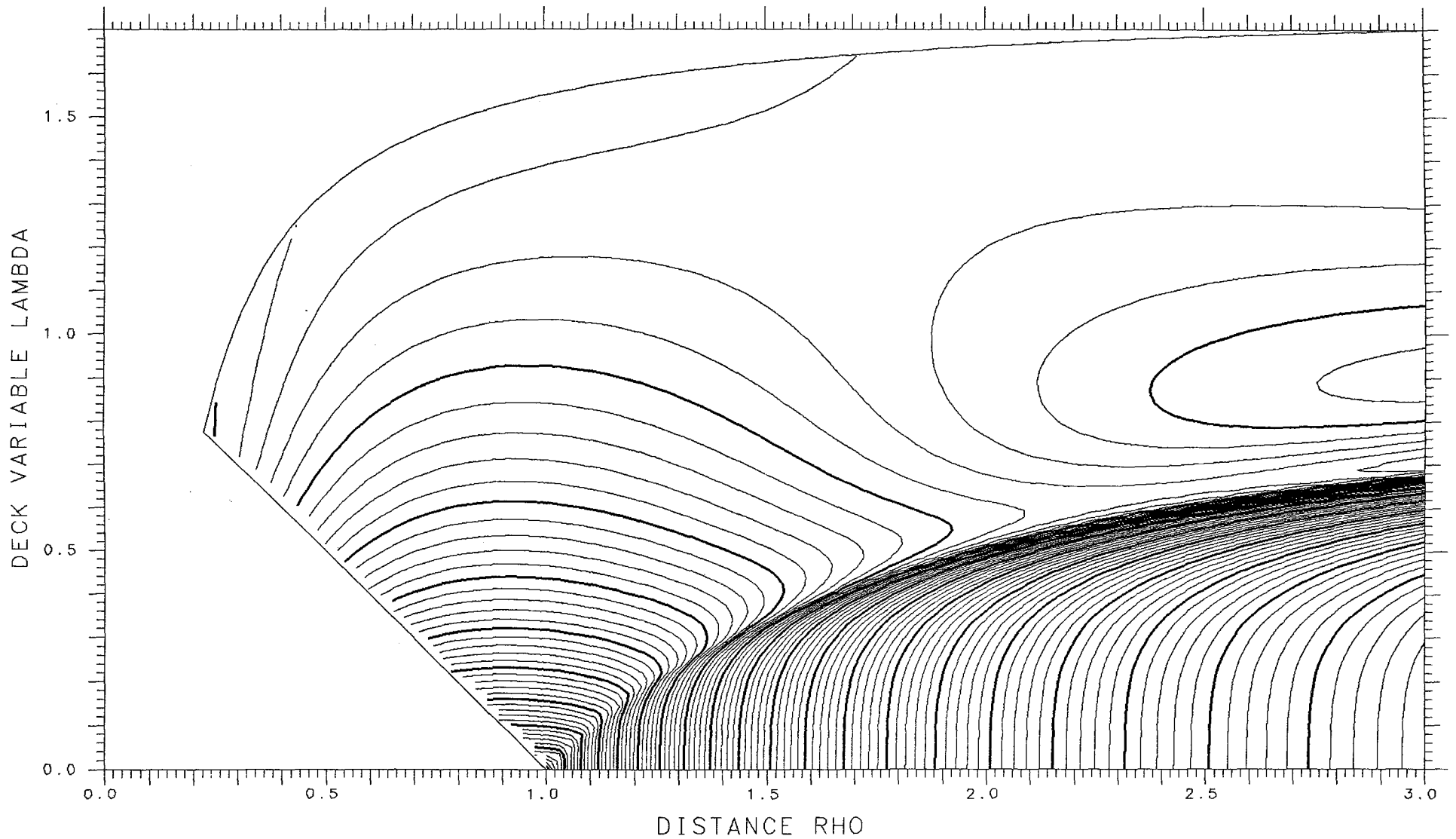

X= .625

ASYMMETRY DELTA= .225

FRACTIONAL= .7979

SPHERES -.10031

TANGENT .12150

LENGTH 10.503

ENERGY 538.09

SPACING .002

SADDLE .07395

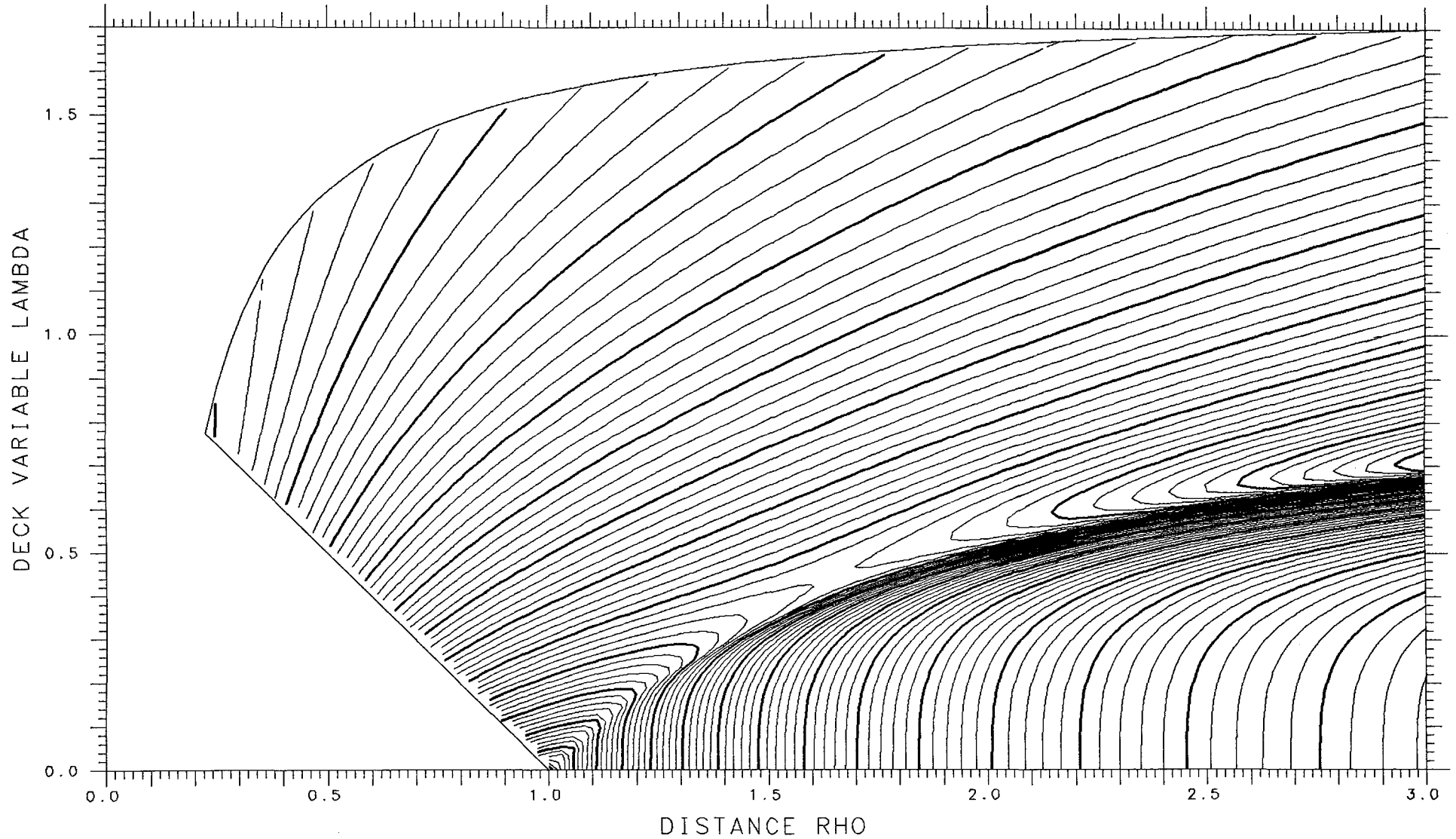

X= .850 ASYMMETRY DELTA= .200 FRACTIONAL= .7714

SPHERES -.23669 TANGENT .09015 LENGTH 11.997 ENERGY 668.85 SPACING .002 SADDLE -.00367

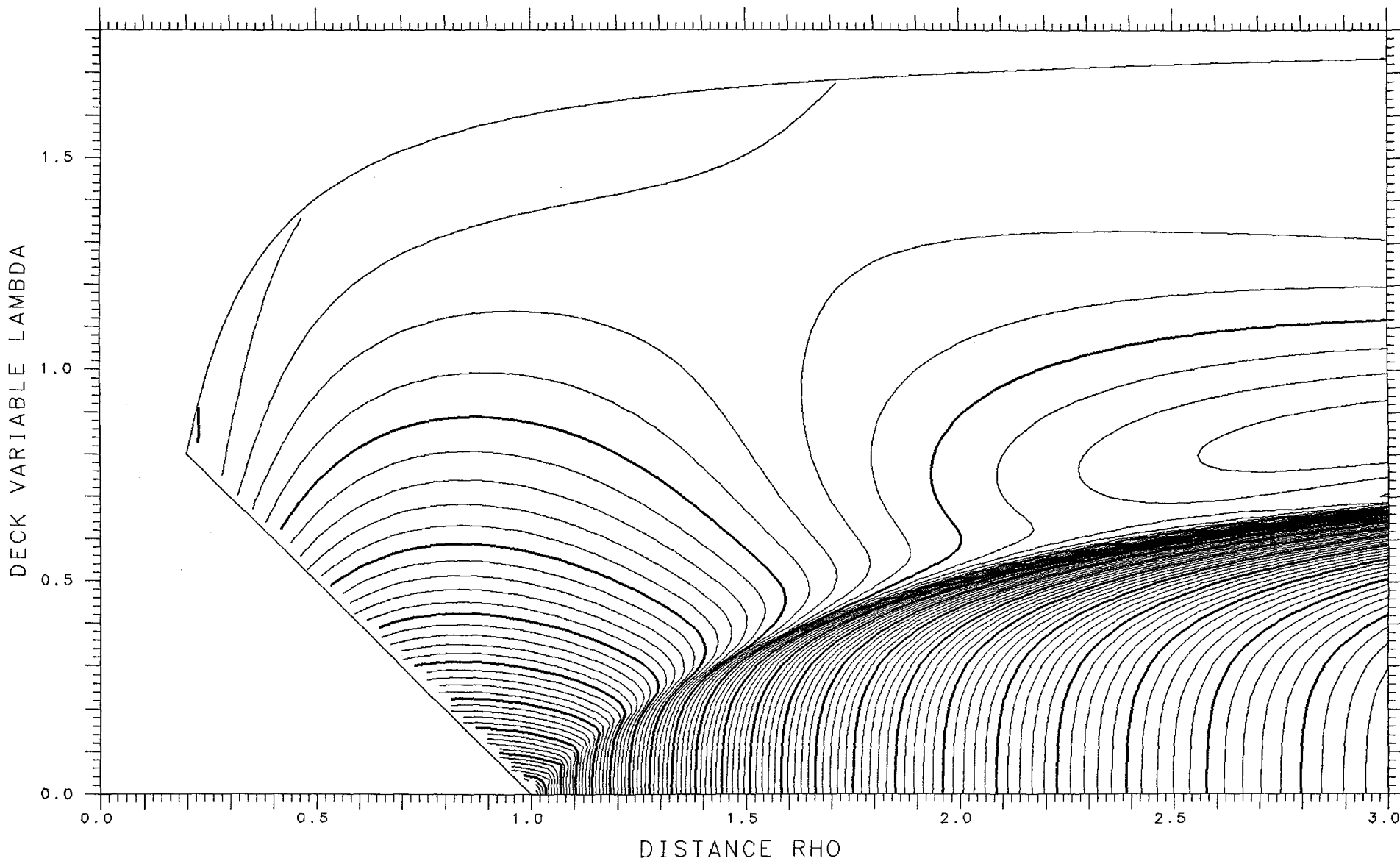

X= .625 ASYMMETRY DELTA= .250 FRACTIONAL= .8224

SPHERES -.08377 TANGENT .11925 LENGTH 10.397 ENERGY 538.09 SPACING .002 SADDLE .07705

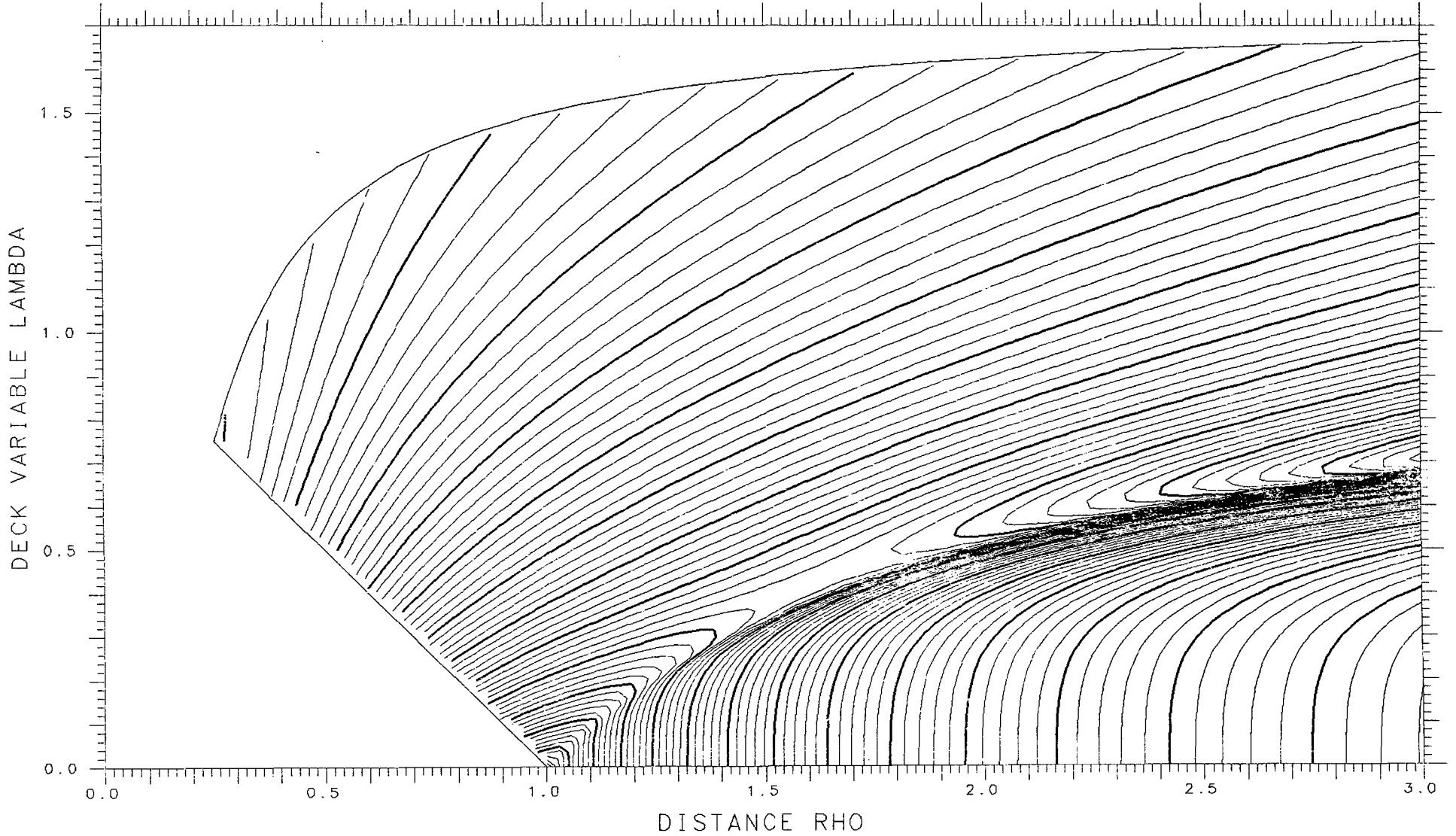

X= .850 ASYMMETRY DELTA= .175 FRACTIONAL= .7429

SPHERES -.26278 TANGENT .08830 LENGTH 12.099 ENERGY 668.85 SPACING .002 SADDLE -.01327

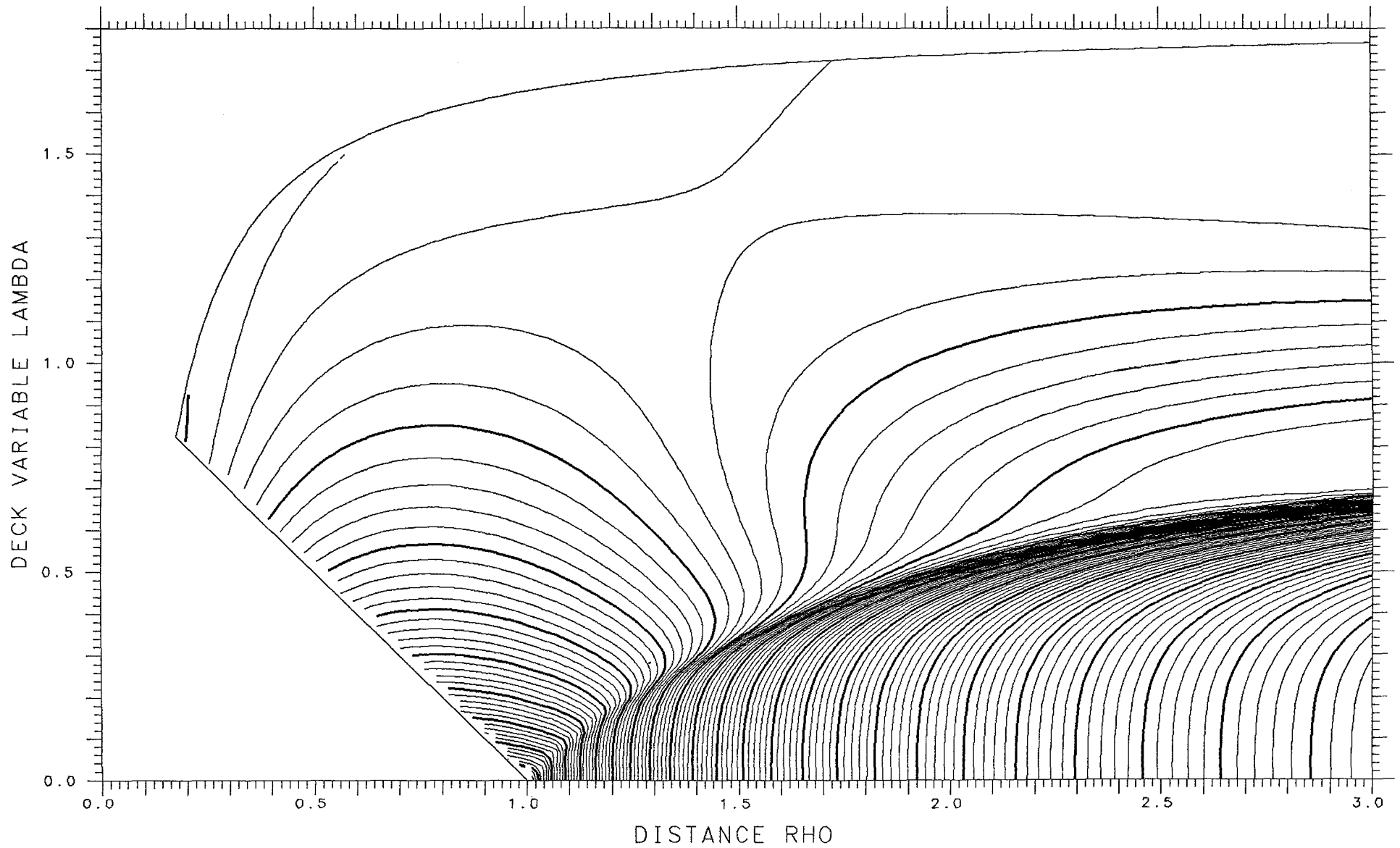

X= .625 ASYMMETRY DELTA= .275 FRACTIONAL= .8447

SPHERES -.06790 TANGENT .11641 LENGTH 10.284 ENERGY 538.09 SPACING .002 SADDLE .07950

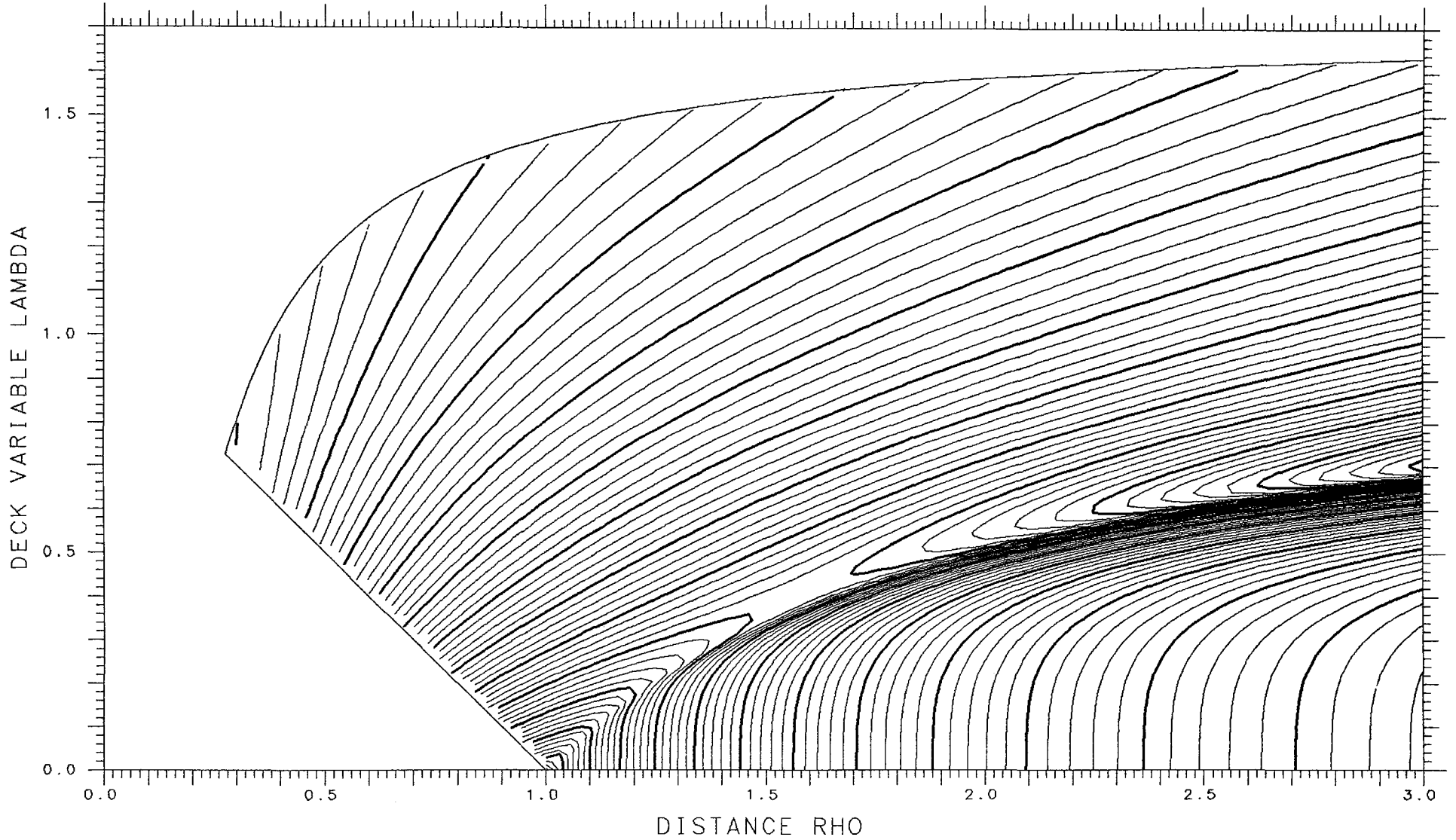

X= .850 ASYMMETRY DELTA= .150 FRACTIONAL= .7124

SPHERES -.28762 TANGENT .08616 LENGTH 12.191 ENERGY 668.85 SPACING .002 SADDLE .00385

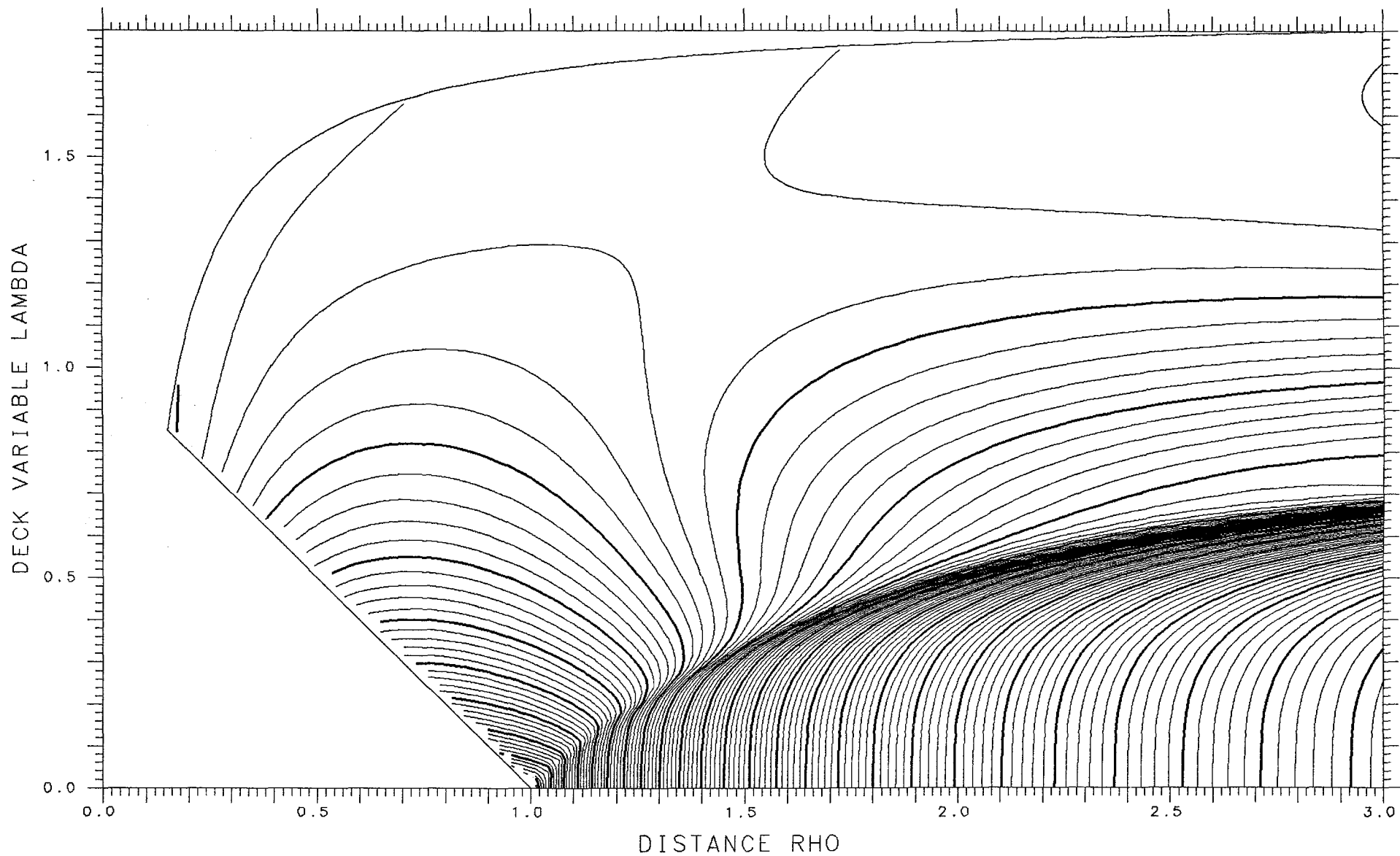

X= .625 ASYMMETRY DELTA= .300 FRACTIONAL= .8650

SPHERES -.05301 TANGENT .11300 LENGTH 10.167 ENERGY 538.09 SPACING .002 SADDLE .08115

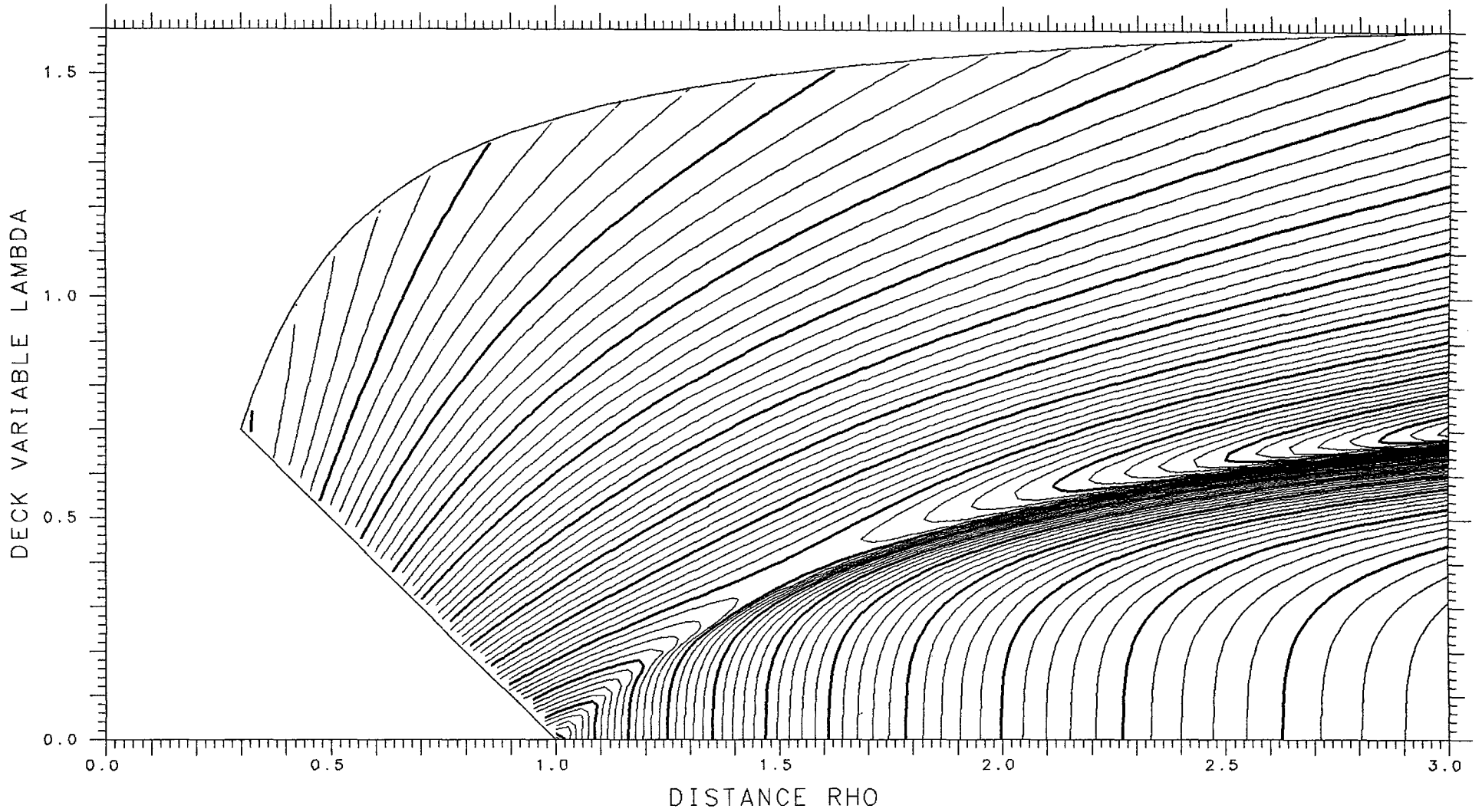

X= .850 ASYMMETRY DELTA= .125 FRACTIONAL= .6800

SPHERES -.31043 TANGENT .08392 LENGTH 12.270 ENERGY 668.85 SPACING .002 SADDLE .00361

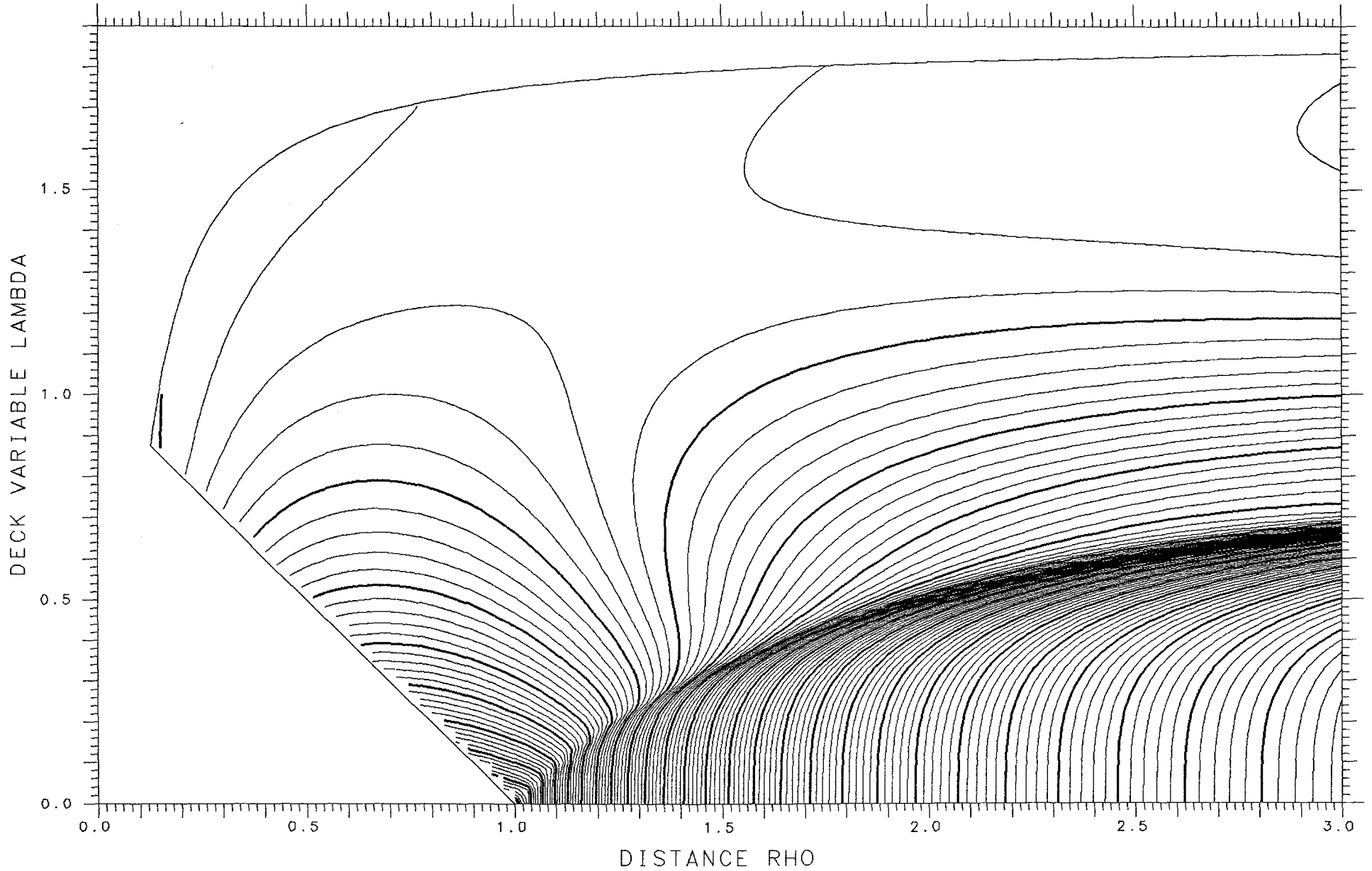

X= .625 ASYMMETRY DELTA= .325 FRACTIONAL= .8832

SPHERES -.03935 TANGENT .10902 LENGTH 10.045 ENERGY 538.09 SPACING .002 SADDLE .08191

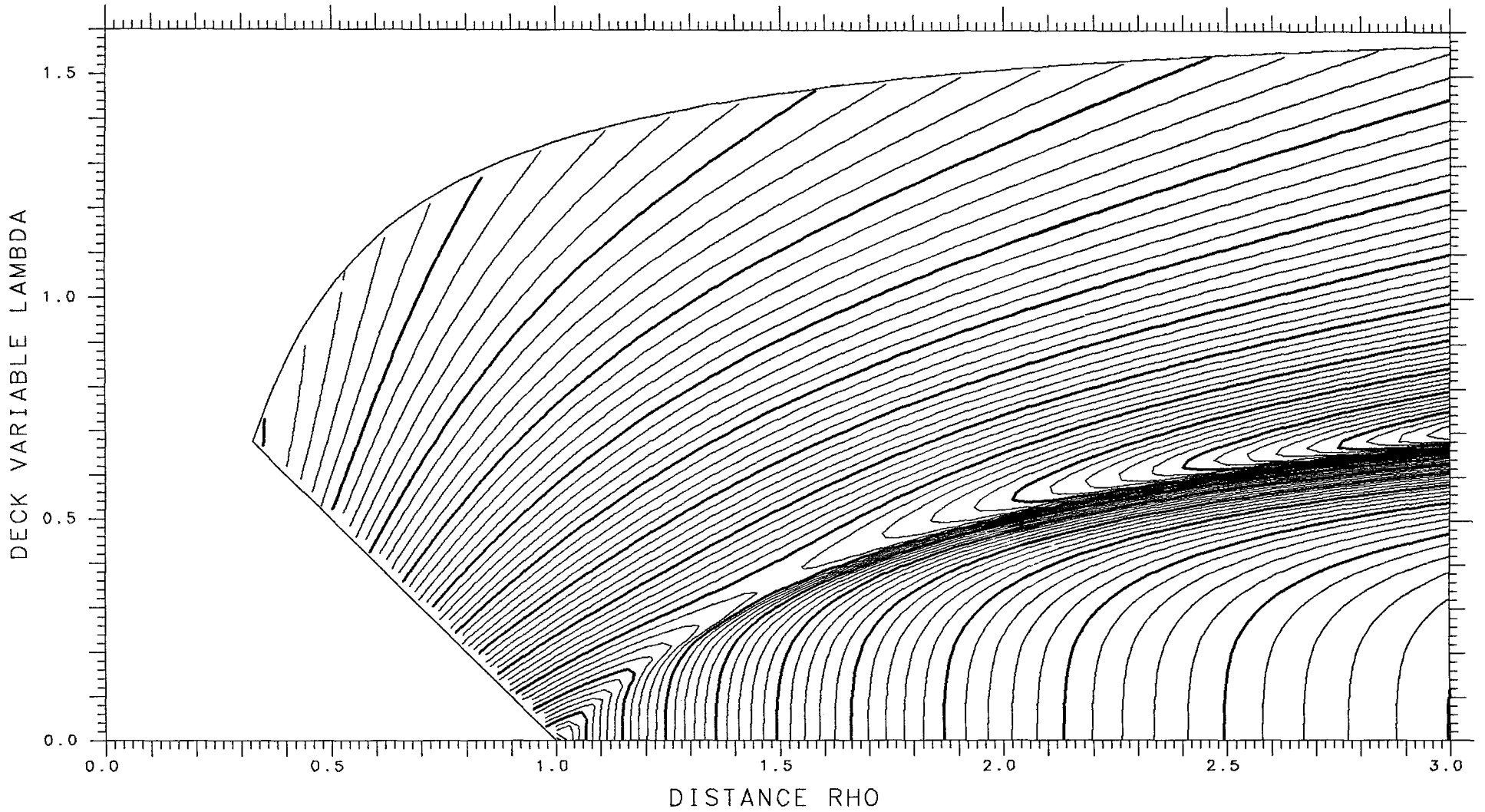

X= .850 ASYMMETRY DELTA= .100 FRACTIONAL= .6461

SPHERES -.33040 TANGENT .08175 LENGTH 12.337 ENERGY 668.85 SPACING .002 SADDLE .00338

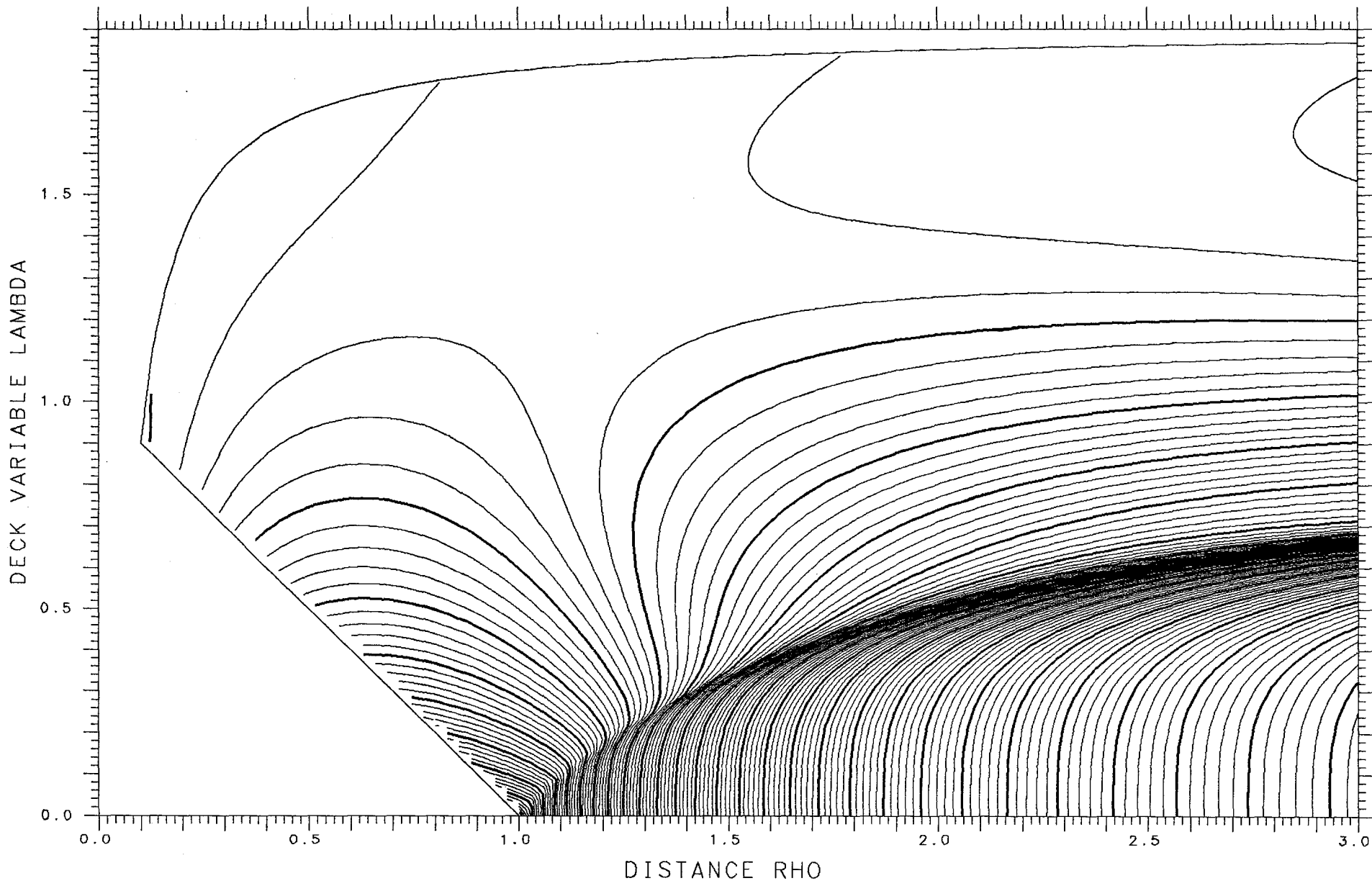

X= .625 ASYMMETRY DELTA= .350 FRACTIONAL= .8996

SPHERES -.02707 TANGENT .10451 LENGTH 9.919 ENERGY 538.09 SPACING .002 SADDLE .08176

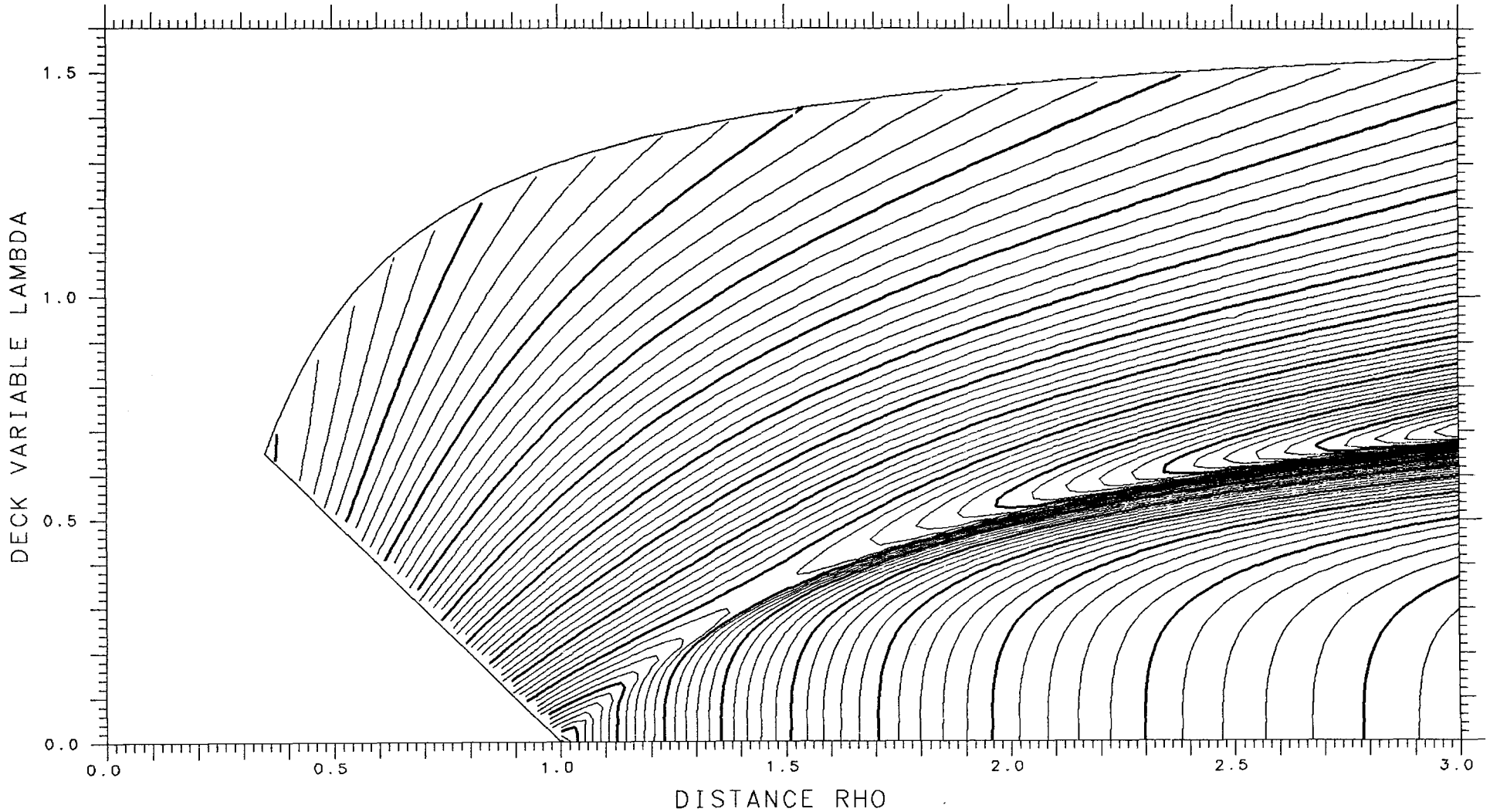

X = .850

ASYMMETRY DELTA = .075

FRACTIONAL = .6108

SPHERES -.34682

TANGENT .07984

LENGTH 12.390

ENERGY 668.85

SPACING .002

SADDLE .00316

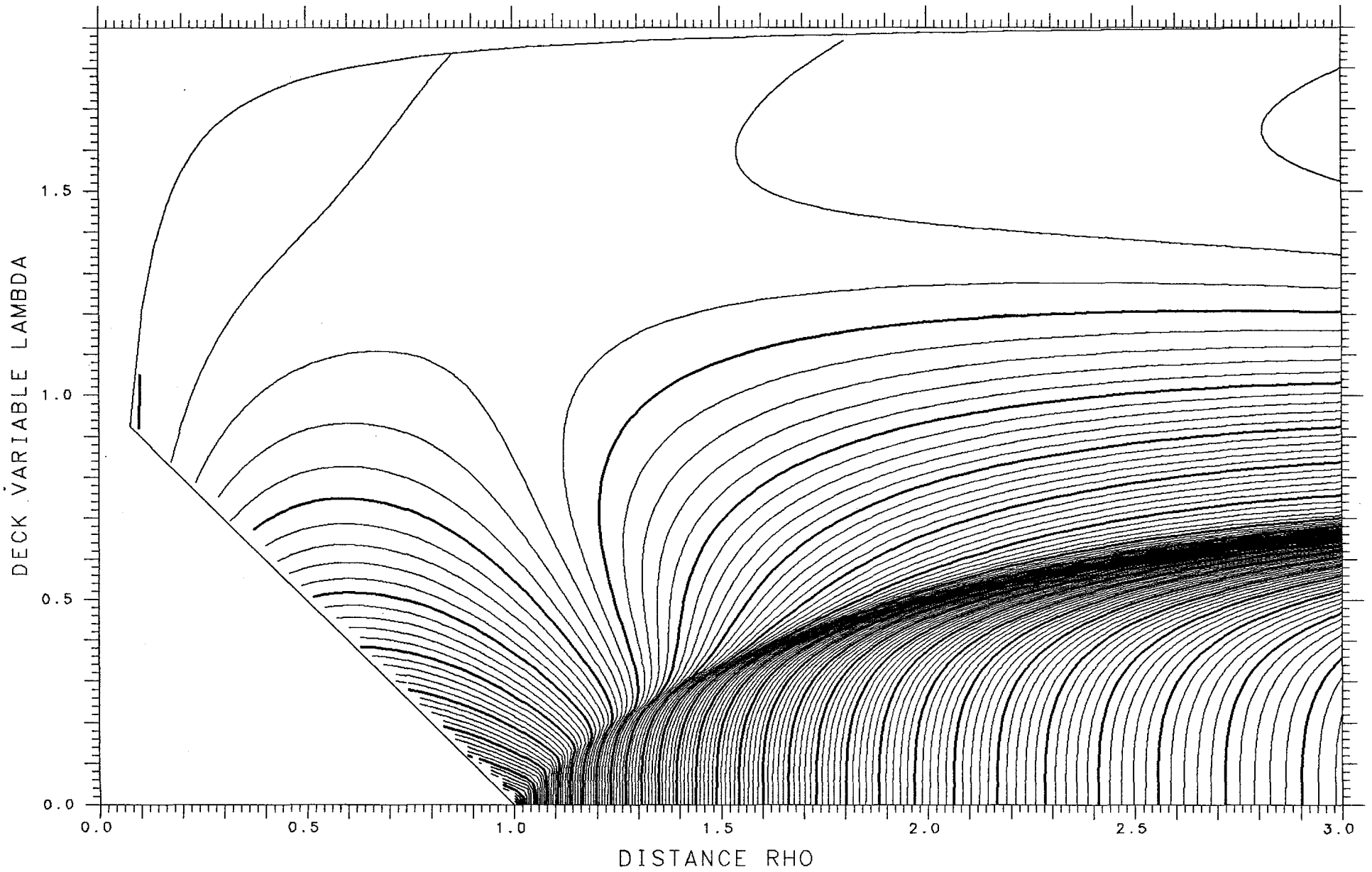

X= .625 ASYMMETRY DELTA= .375 FRACTIONAL= .9141

SPHERES -.01628 TANGENT .09954 LENGTH 9.791 ENERGY 538.09 SPACING .002 SADDLE .08071

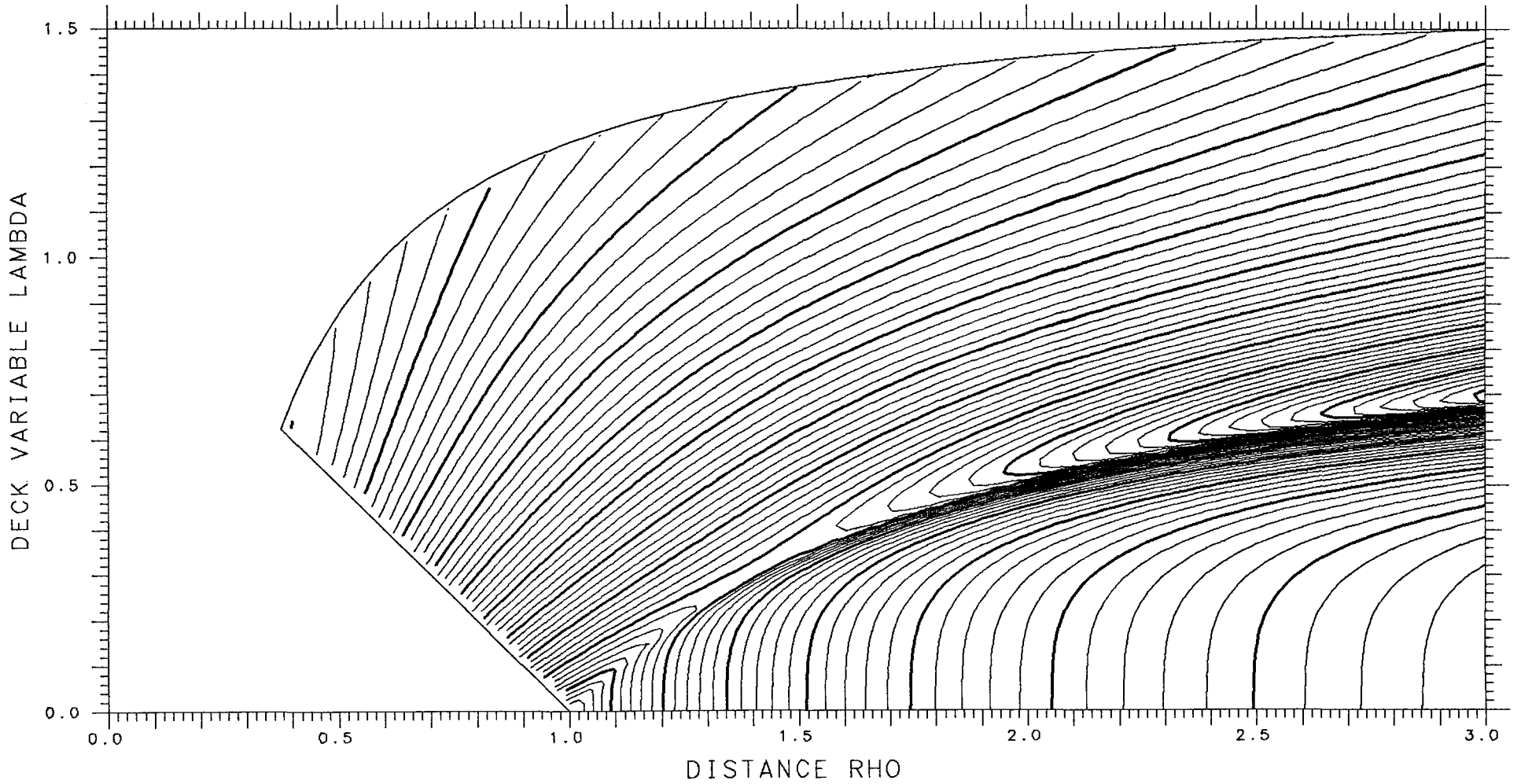

X= .850 ASYMMETRY DELTA= .050 FRACTIONAL= .5745

SPHERES -.35905 TANGENT .07835 LENGTH 12.428 ENERGY 668.85 SPACING .002 SADDLE .00298

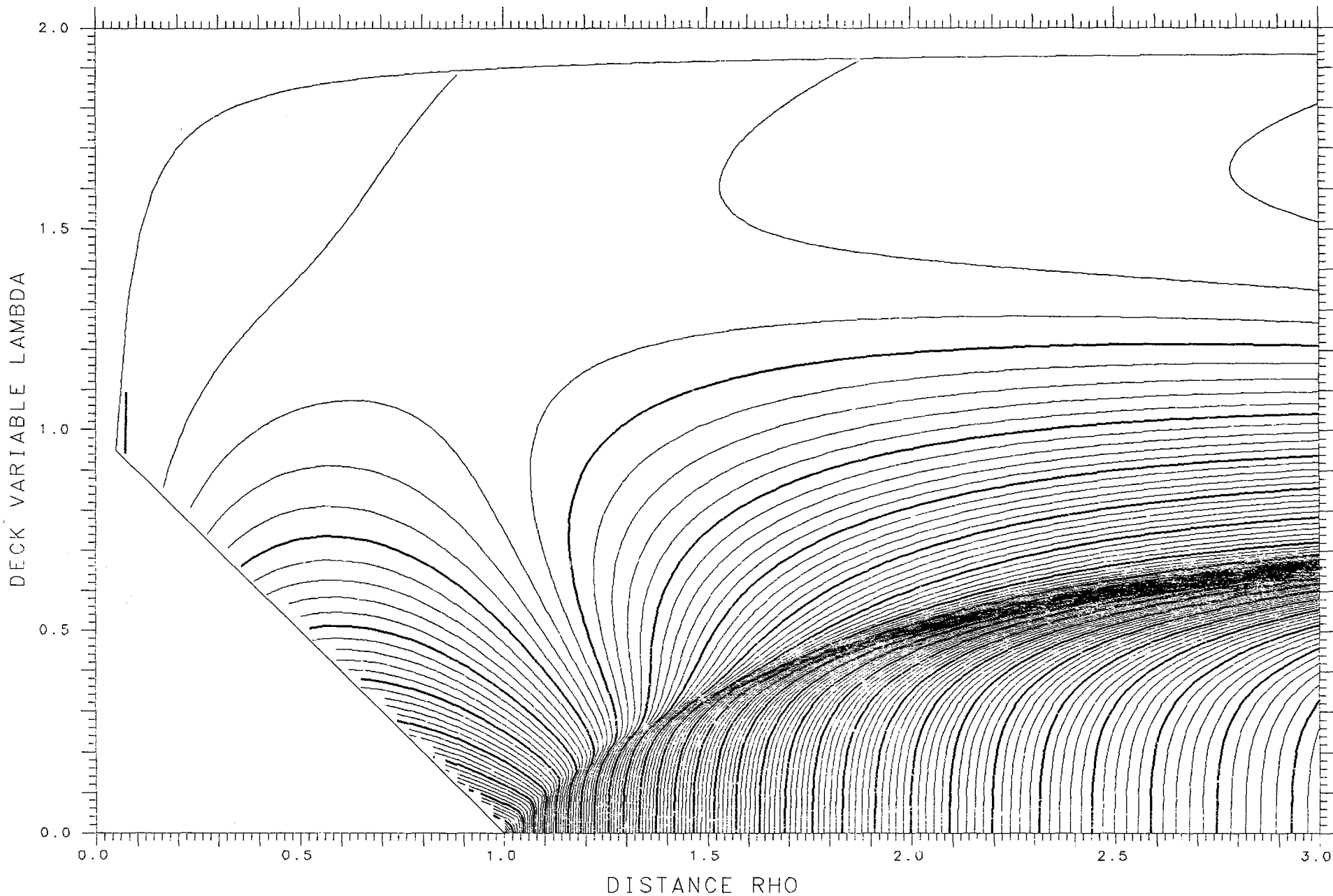

X= .625 ASYMMETRY DELTA= .400 FRACTIONAL= .9270

SPHERES -.00700 TANGENT .09417 LENGTH 9.661 ENERGY 538.09 SPACING .002 SADDLE .07880

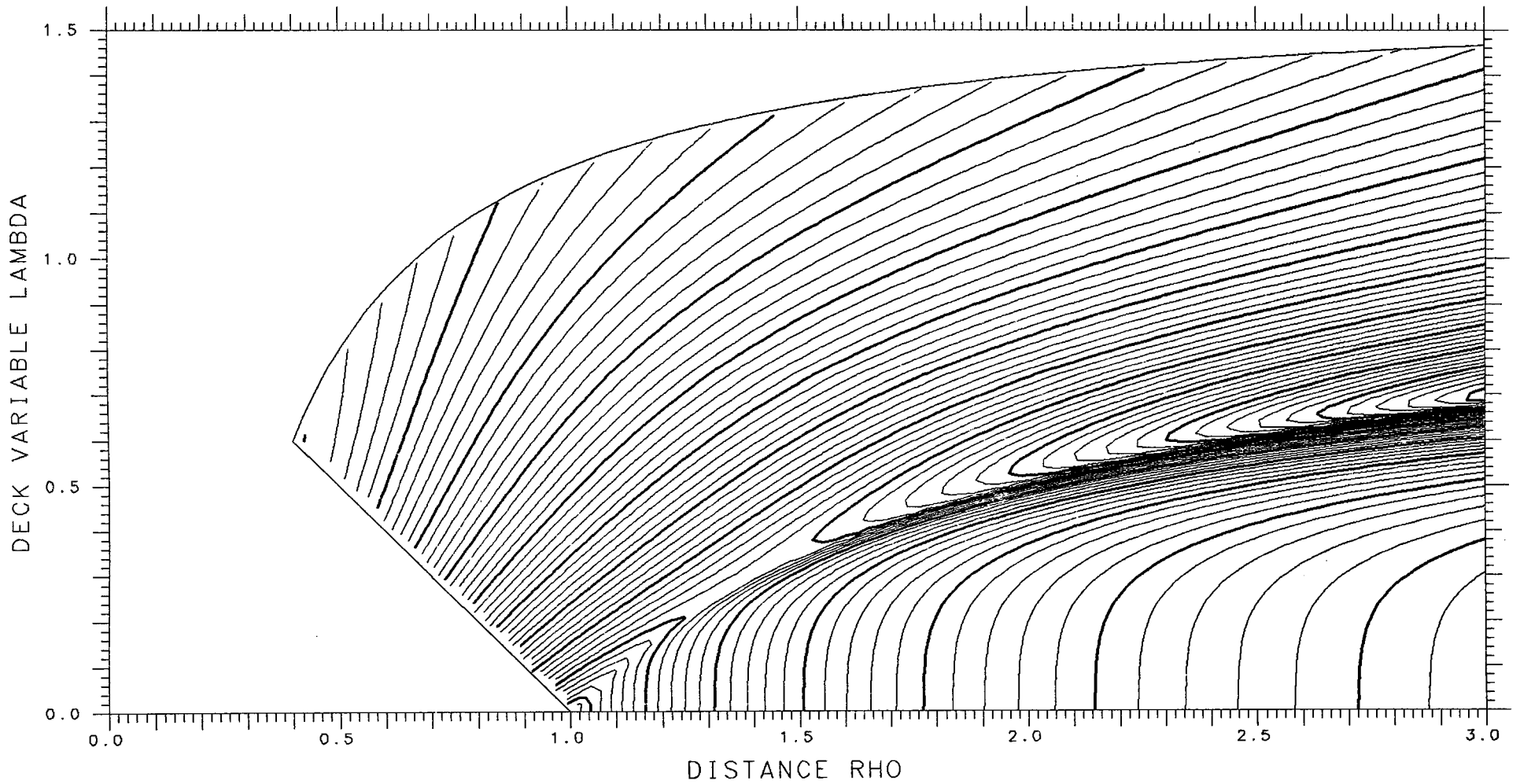

X= .850

ASYMMETRY DELTA= .025

FRACTIONAL= .5374

SPHERES -.36660

TANGENT .07740

LENGTH 12.451

ENERGY 668.85

SPACING .002

SADDLE .00286

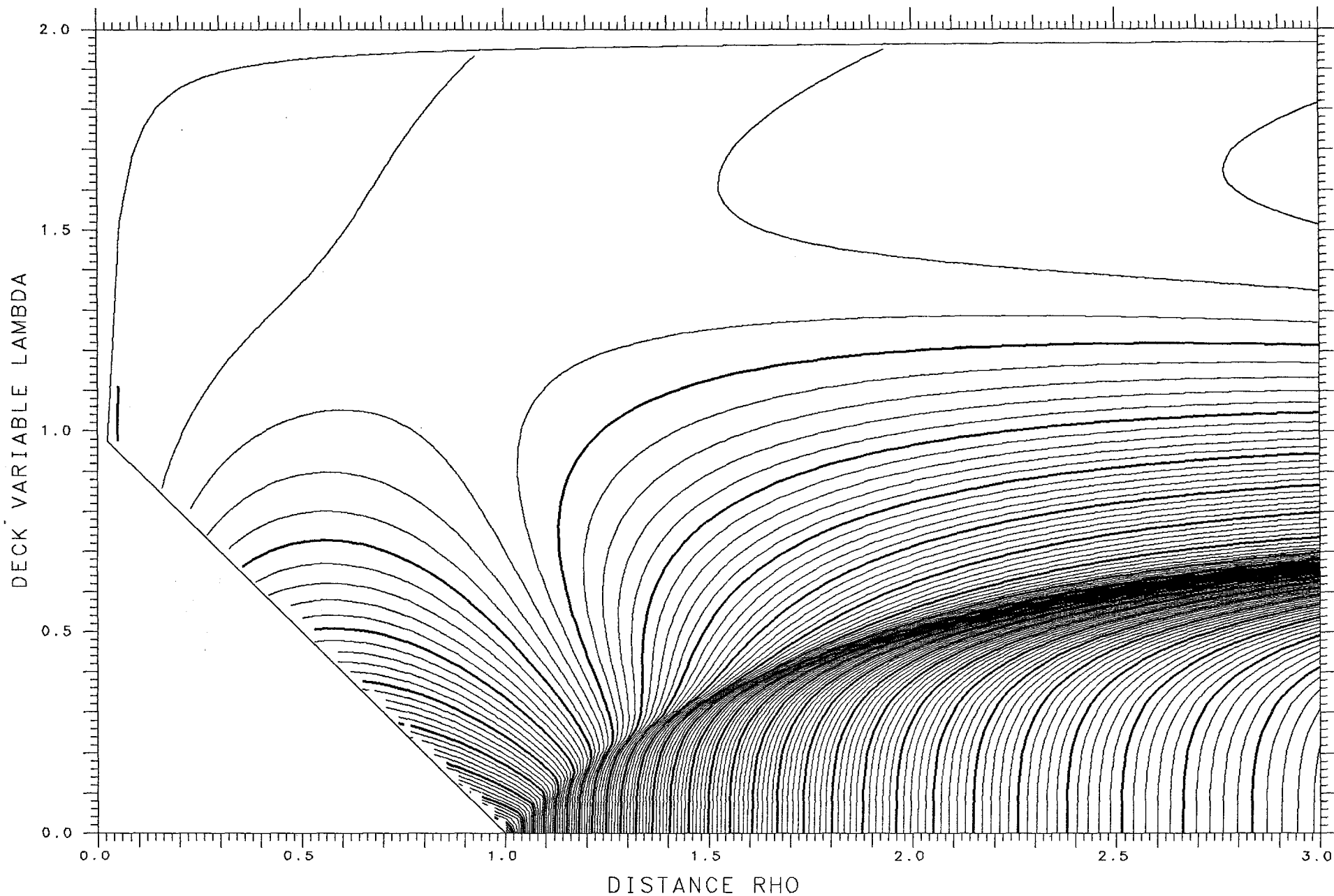

X= .625 ASYMMETRY DELTA= .425 FRACTIONAL= .9384

SPHERES .00077 TANGENT .08848 LENGTH 9.530 ENERGY 538.09 SPACING .002

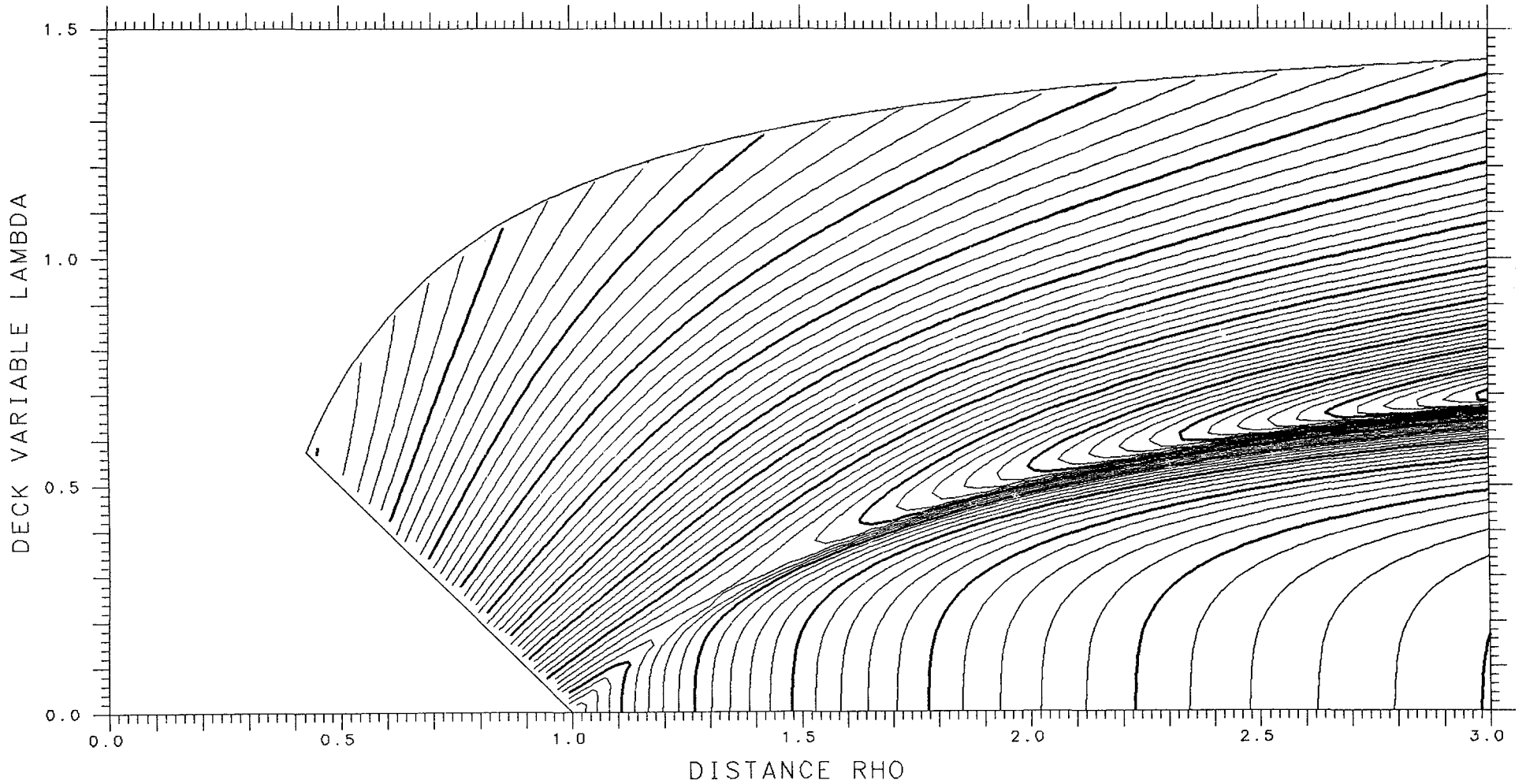

X= .850

ASYMMETRY DELTA=0.

FRACTIONAL= .5000

SPHERES -.36915

TANGENT .07708

LENGTH 12.459

ENERGY 668.85

SPACING .002

SADDLE .00282

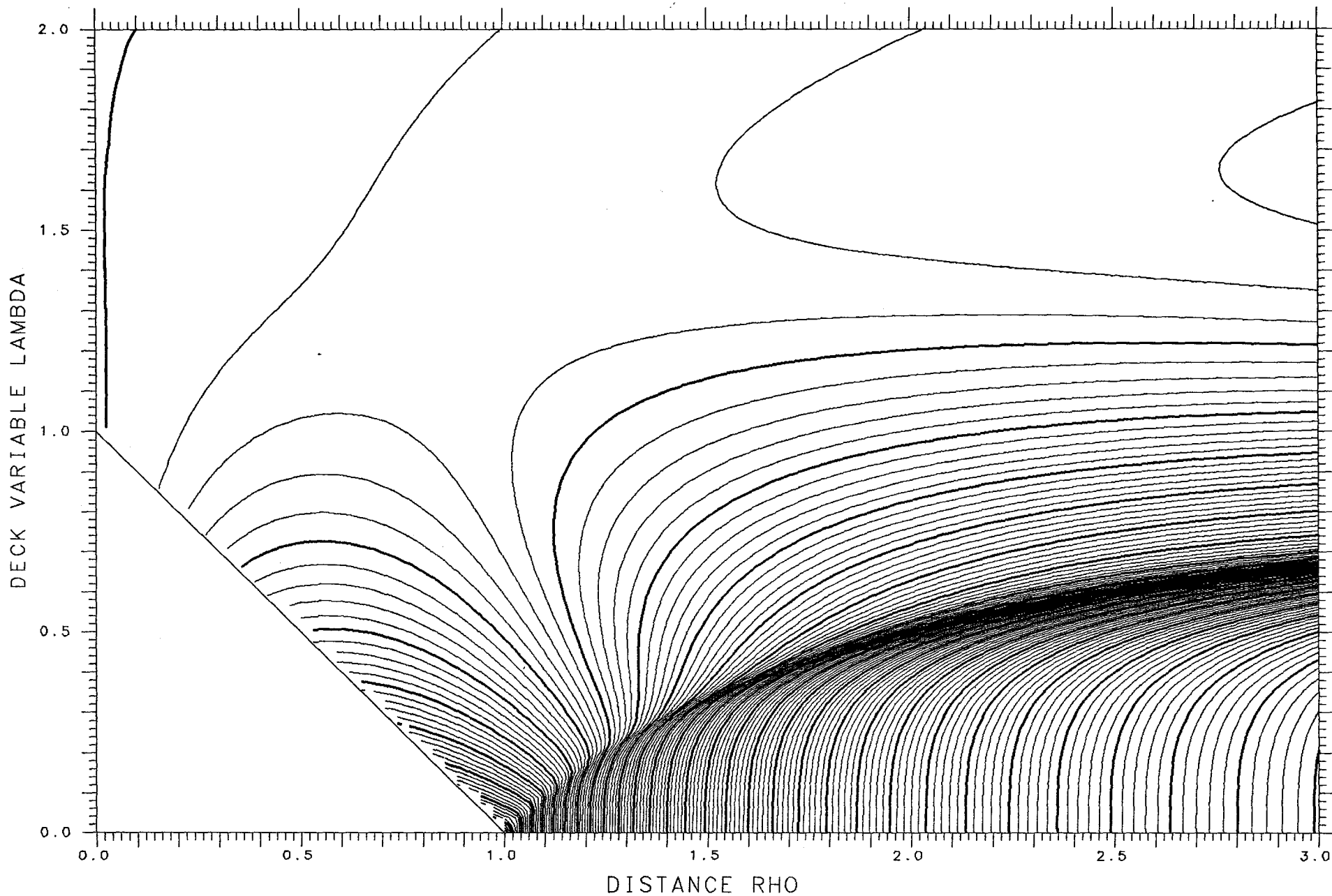

X= .625 ASYMMETRY DELTA= .450 FRACTIONAL= .9483

SPHERES .00711 TANGENT .08255 LENGTH 9.399 ENERGY 538.09 SPACING .002

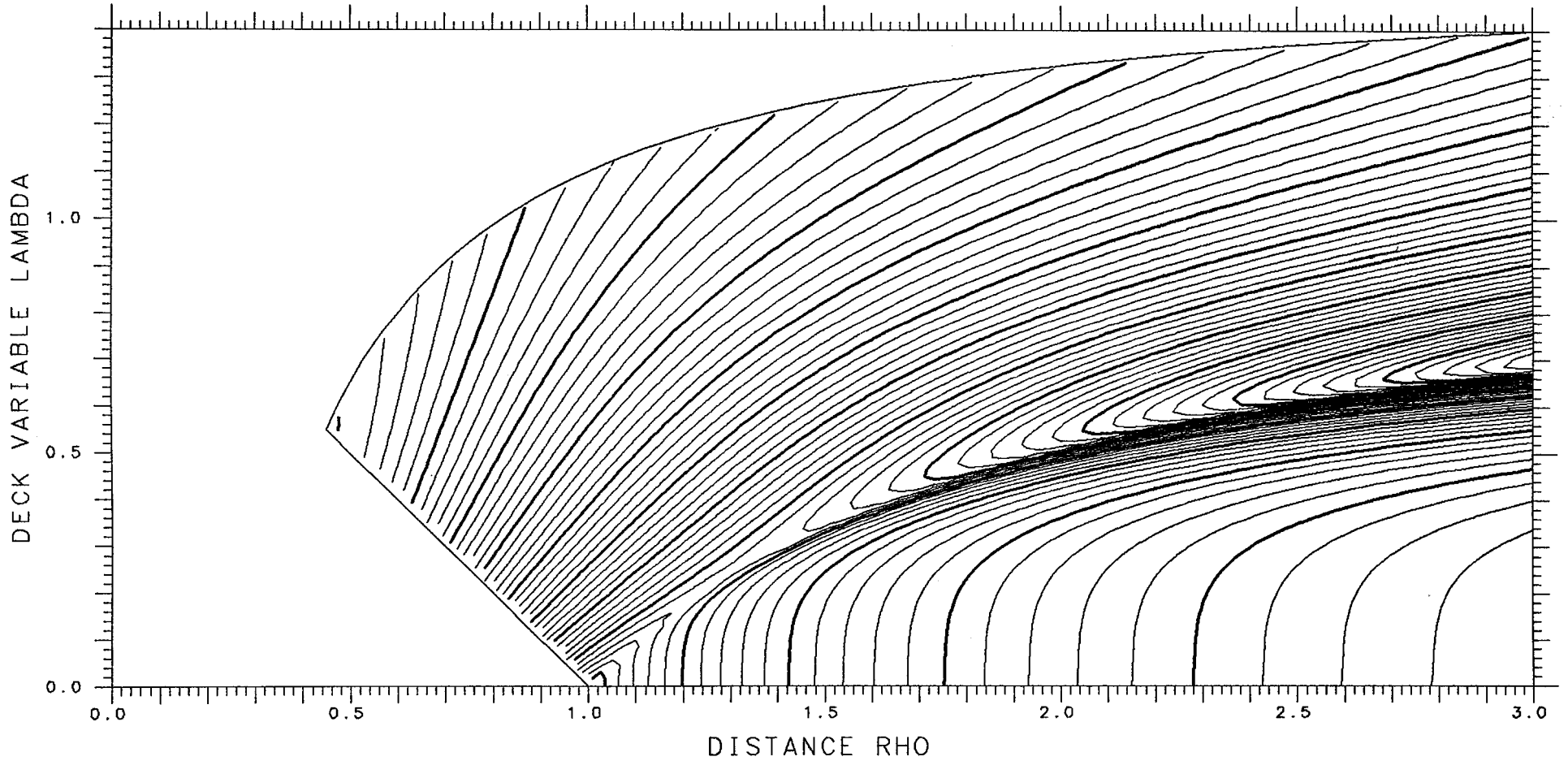

X= .825 ASYMMETRY DELTA= .600 FRACTIONAL= .9846

SPHERES .01105 TANGENT .04455 LENGTH 9.645 ENERGY 655.09 SPACING .002

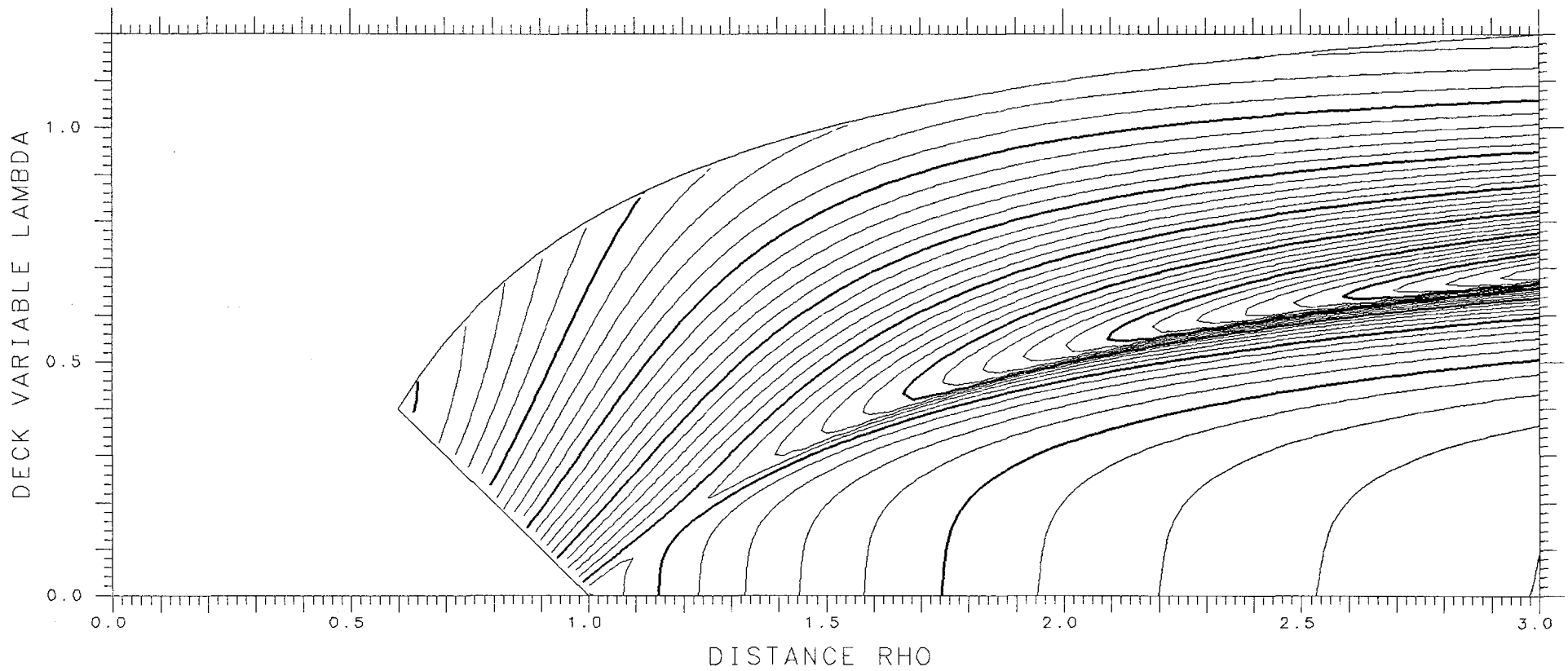

X= .625

ASYMMETRY DELTA= .475

FRACTIONAL= .9569

SPHERES .01209

TANGENT .07646

LENGTH 9.267

ENERGY 538.09

SPACING .002

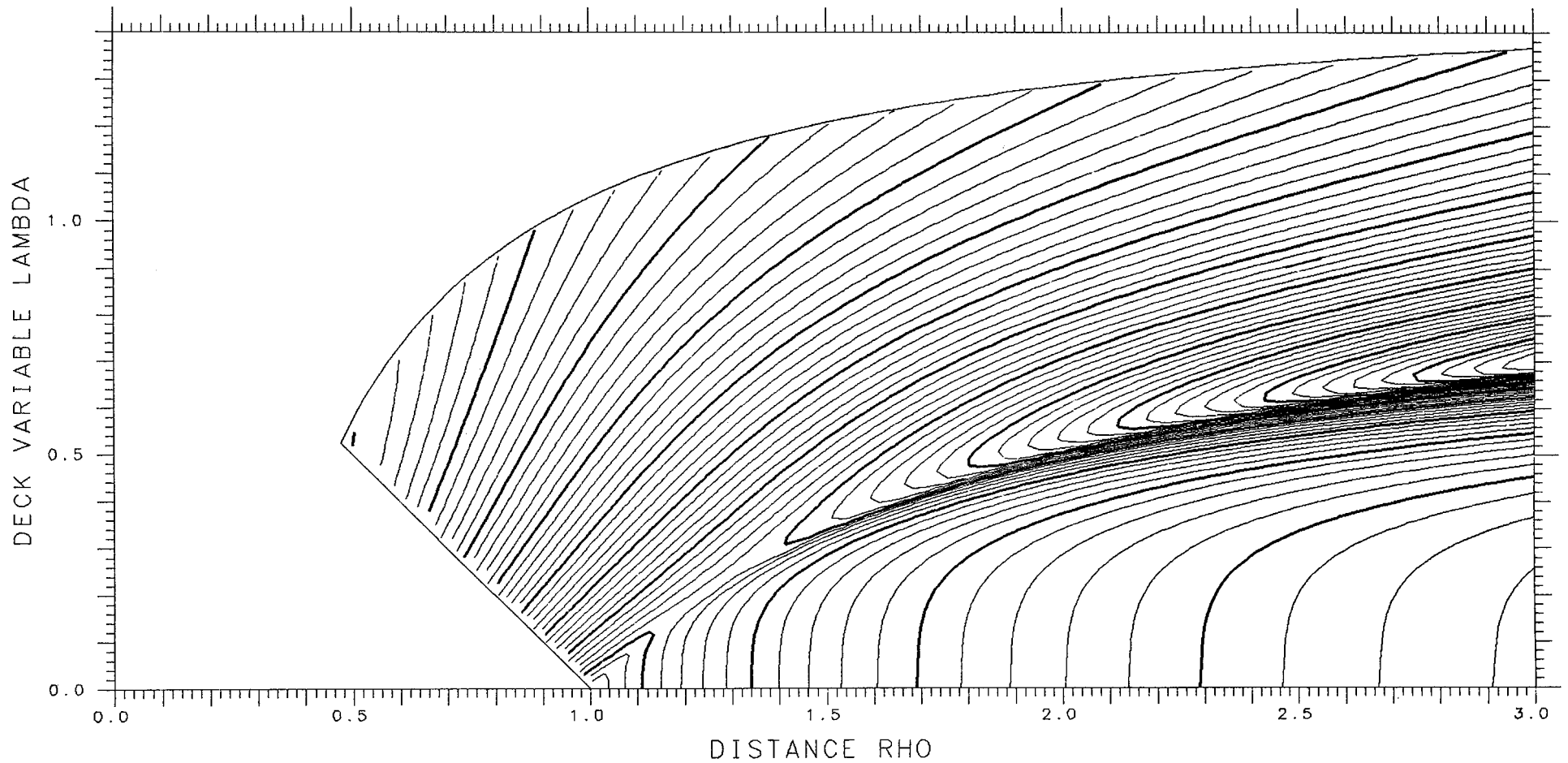

X= .825 ASYMMETRY DELTA= .575 FRACTIONAL= .9807

SPHERES .00862 TANGENT .04982 LENGTH 9.785 ENERGY 655.09 SPACING .002

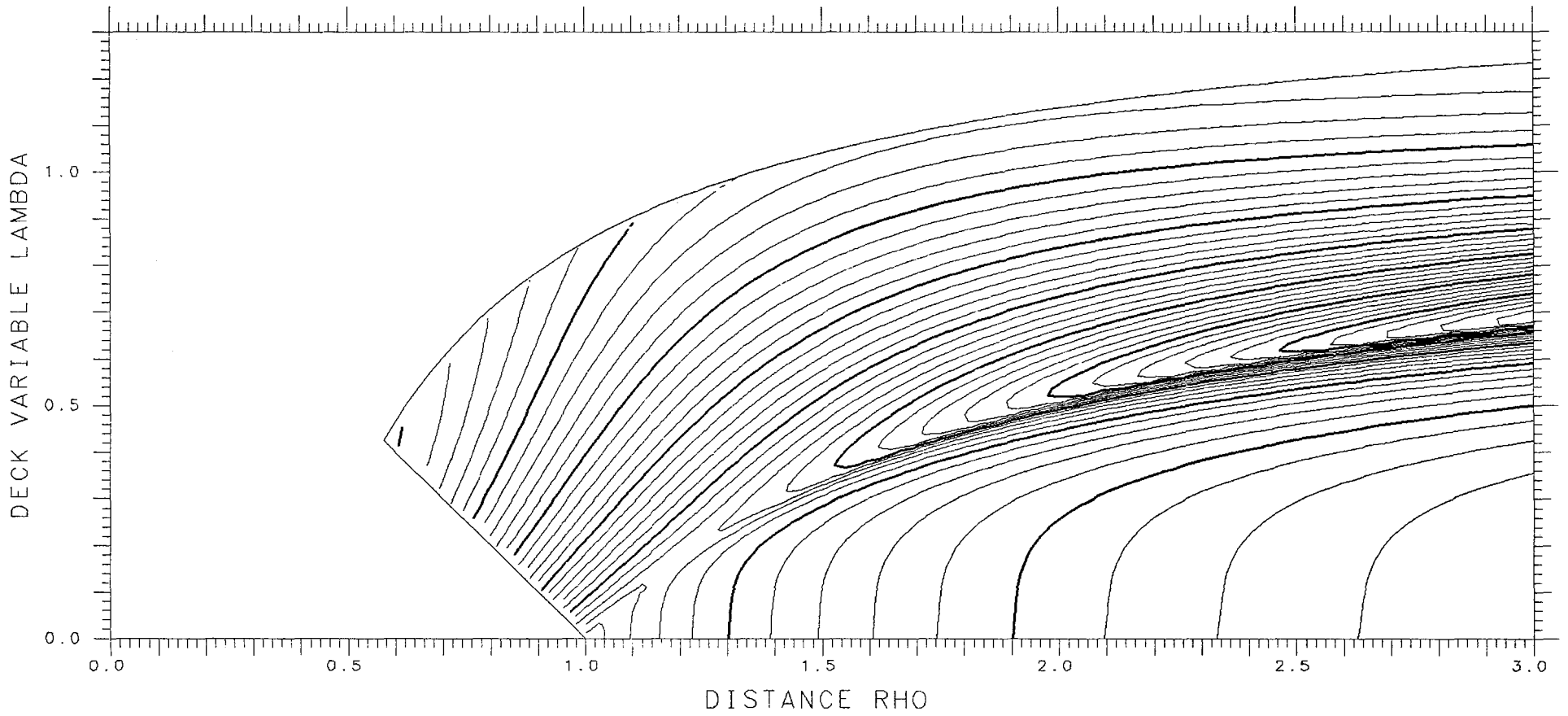

X= .625 ASYMMETRY DELTA= .500 FRACTIONAL= .9643

SPHERES .01582 TANGENT .07029 LENGTH 9.136 ENERGY 538.09 SPACING .002

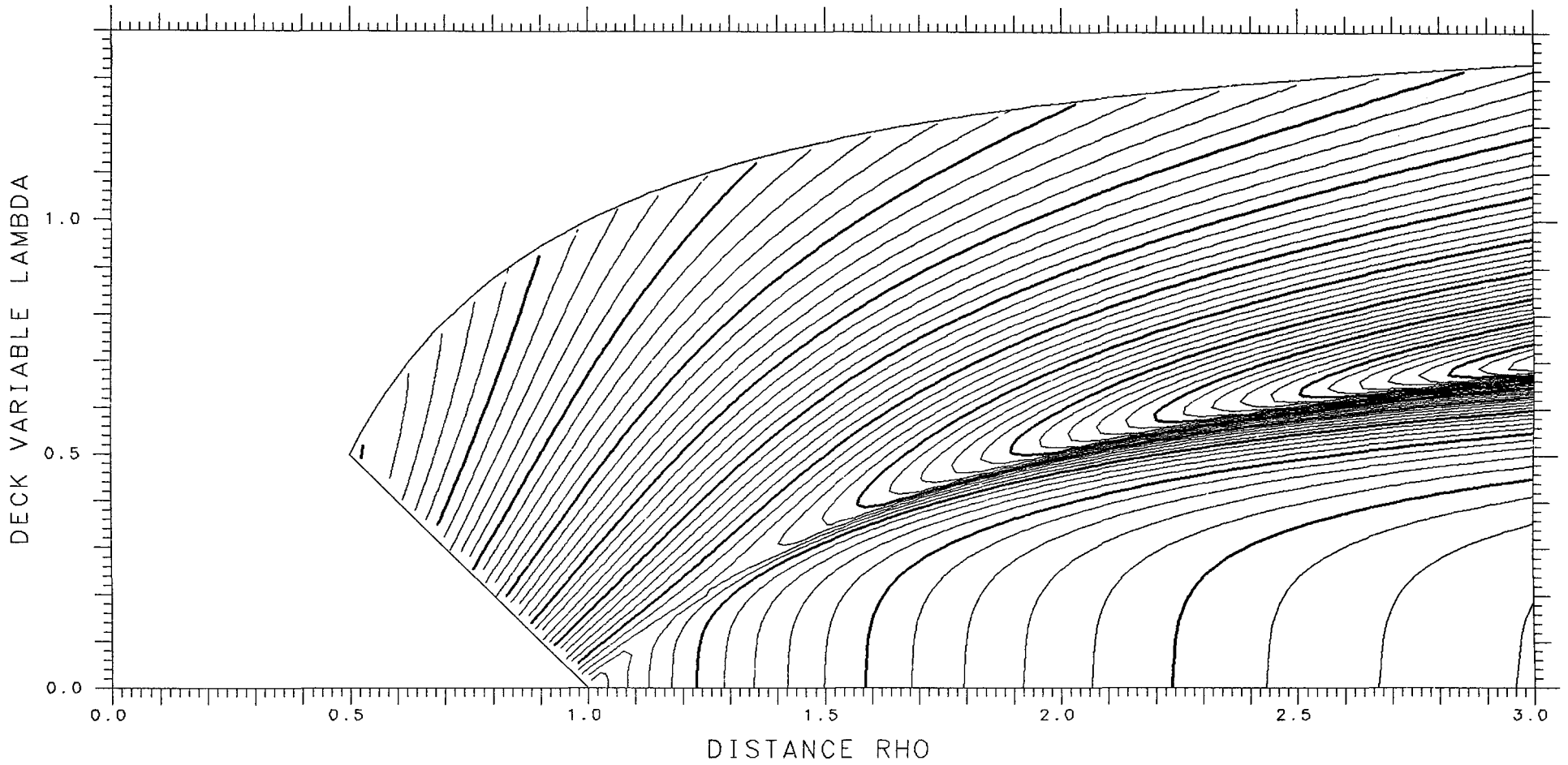

X= .825 ASYMMETRY DELTA= .550 FRACTIONAL= .9761

SPHERES .00506 TANGENT .05515 LENGTH 9.927 ENERGY 655.09 SPACING .002

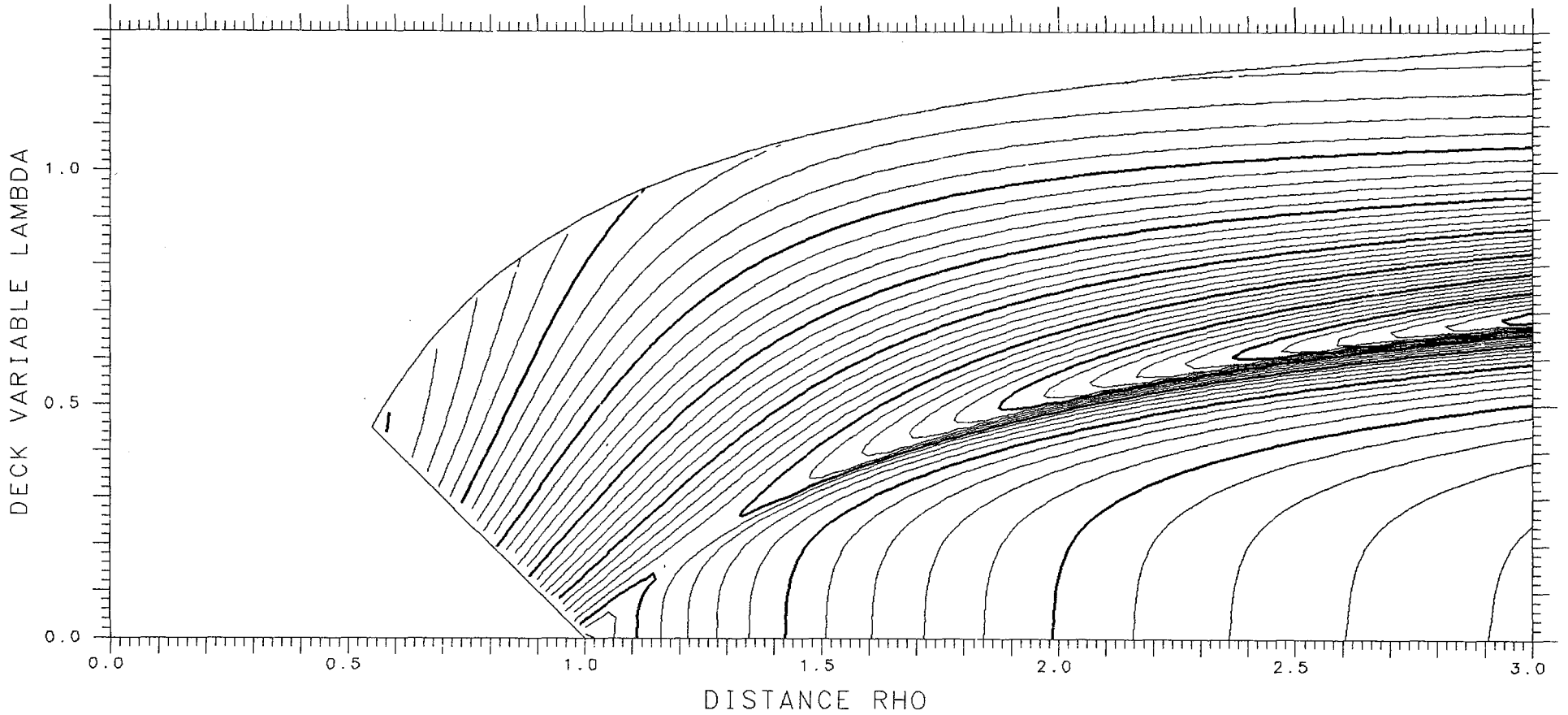

X= .625 ASYMMETRY DELTA= .525 FRACTIONAL= .9707

SPHERES .01844 TANGENT .06412 LENGTH 9.006 ENERGY 538.09 SPACING .002

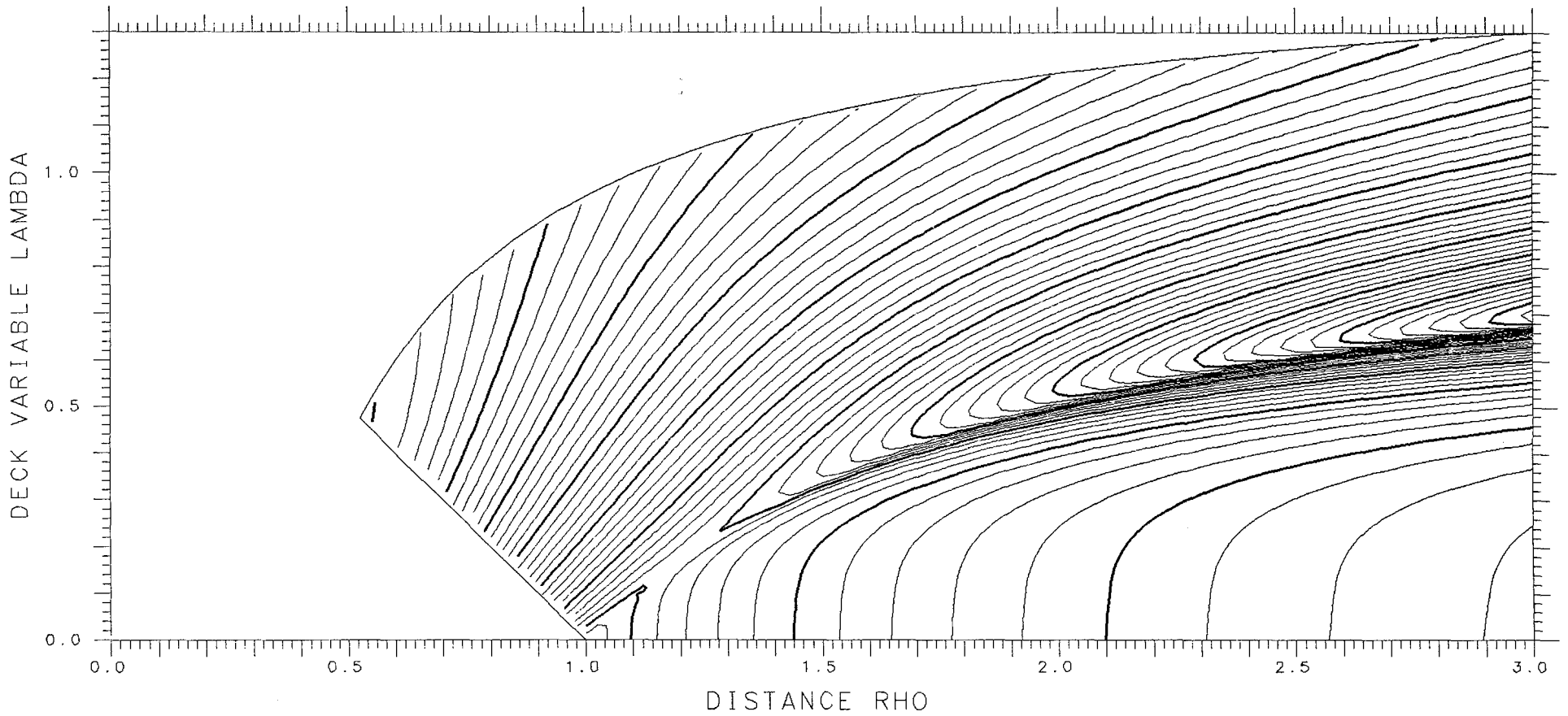

X= .825 ASYMMETRY DELTA= .525 FRACTIONAL= .9707

SPHERES .00019 TANGENT .06049 LENGTH 10.071 ENERGY 655.09 SPACING .002

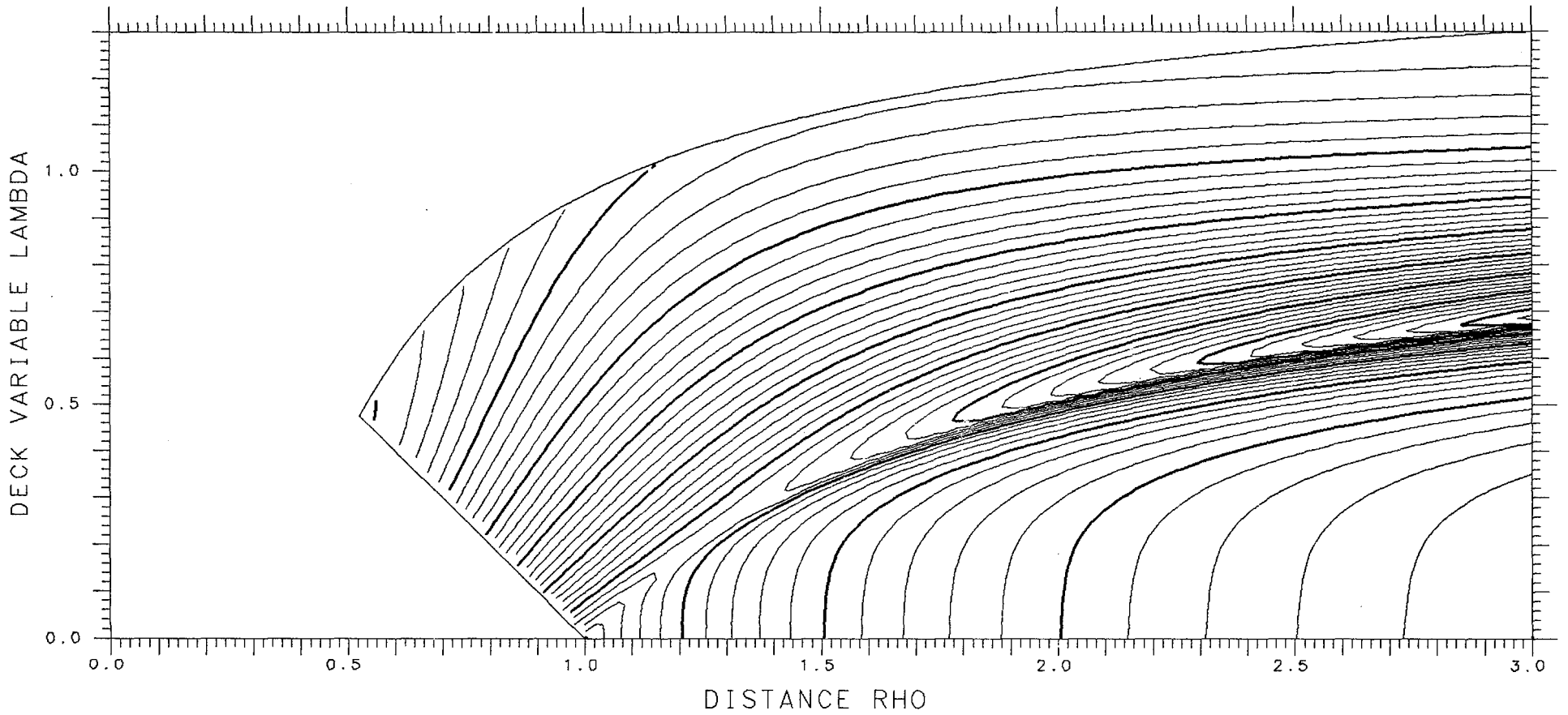

X= .625 ASYMMETRY DELTA= .550 FRACTIONAL= .9761

SPHERES .02006 TANGENT .05801 LENGTH 8.878 ENERGY 538.09 SPACING .002

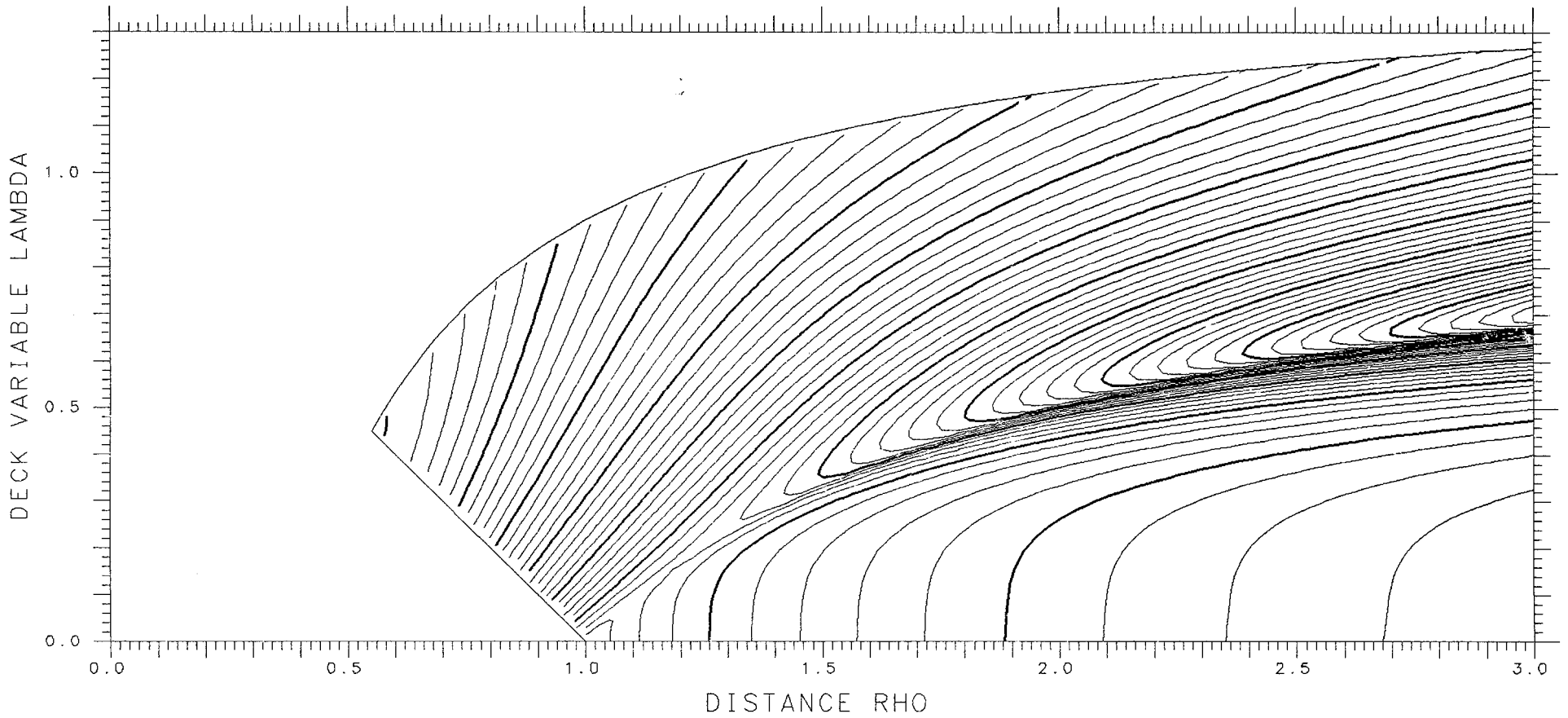

X= .825 ASYMMETRY DELTA= .500 FRACTIONAL= .9643

SPHERES -.00615 TANGENT .06574 LENGTH 10.216 ENERGY 655.09 SPACING .002

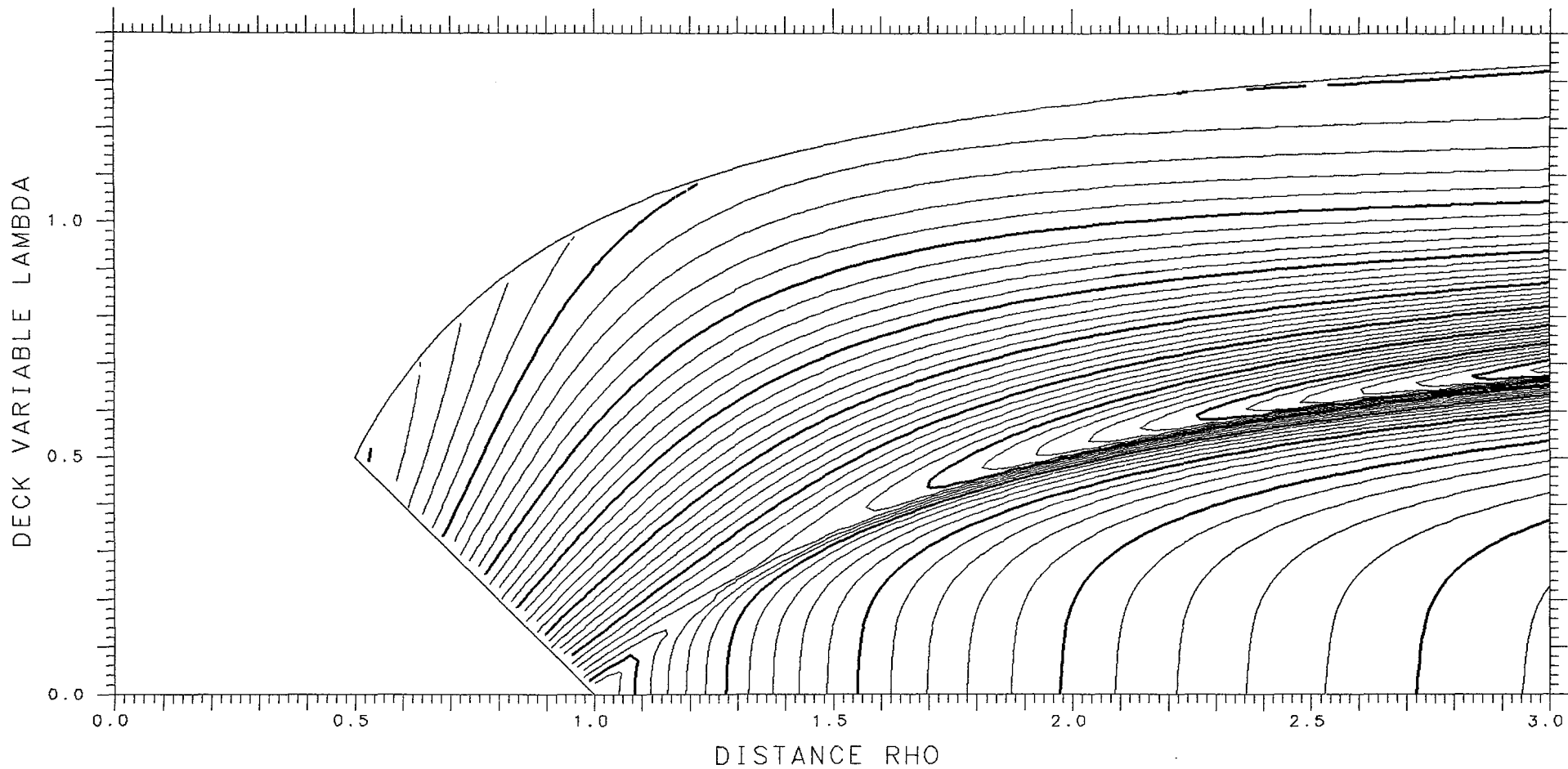

X= .650

ASYMMETRY DELTA=0.

FRACTIONAL= .5000

SPHERES -.22113

TANGENT .12010

LENGTH 11.185

ENERGY 553.46

SPACING .002

SADDLE .04070

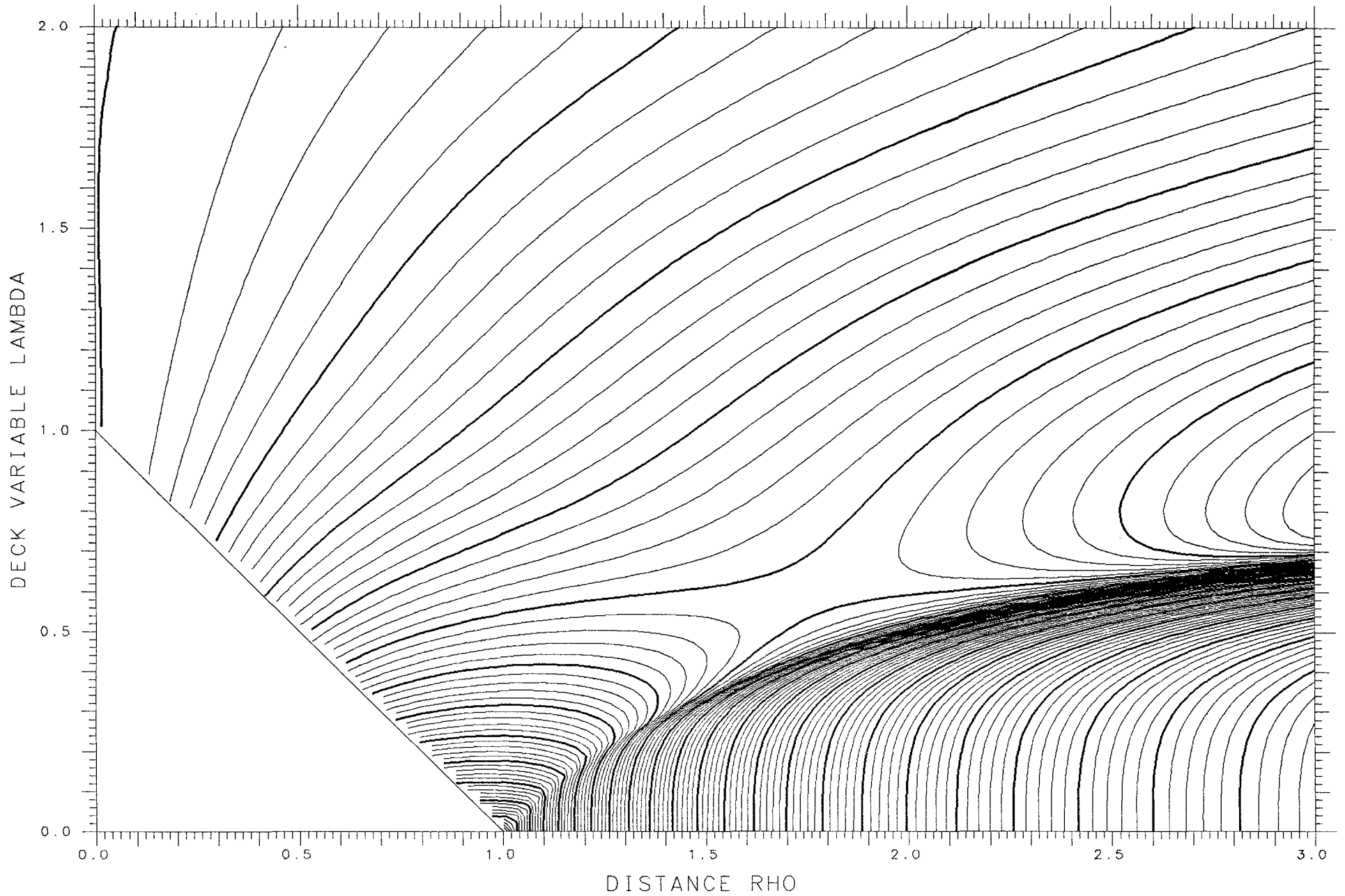

X= .825 ASYMMETRY DELTA= .475 FRACTIONAL= .9569

SPHERES -.01414 TANGENT .07083 LENGTH 10.363 ENERGY 655.09 SPACING .002 SADDLE .05826

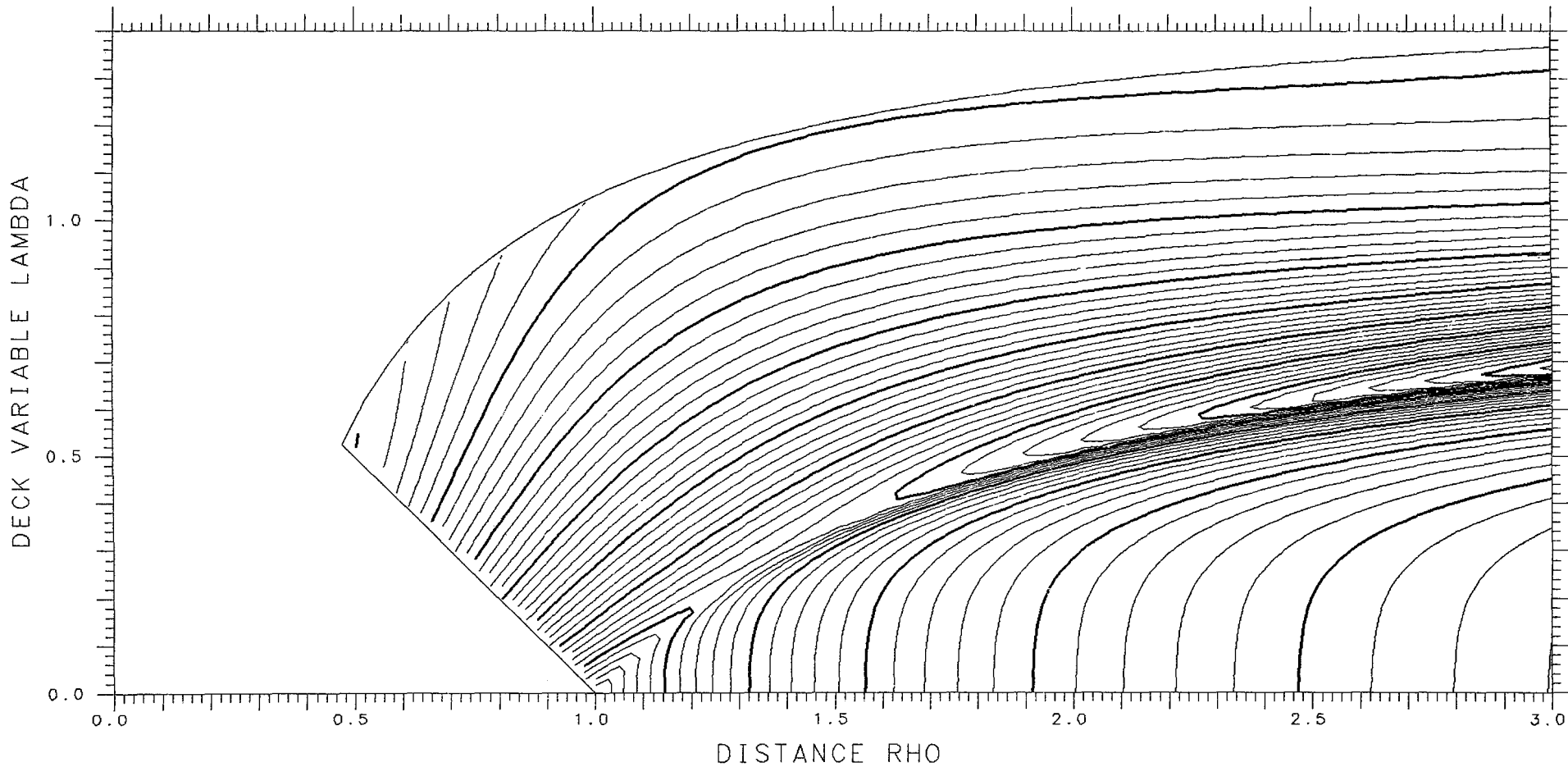

X= .650 ASYMMETRY DELTA= .025 FRACTIONAL= .5374

SPHERES -.21937 TANGENT .12016 LENGTH 11.179 ENERGY 553.46 SPACING .002 SADDLE .04109

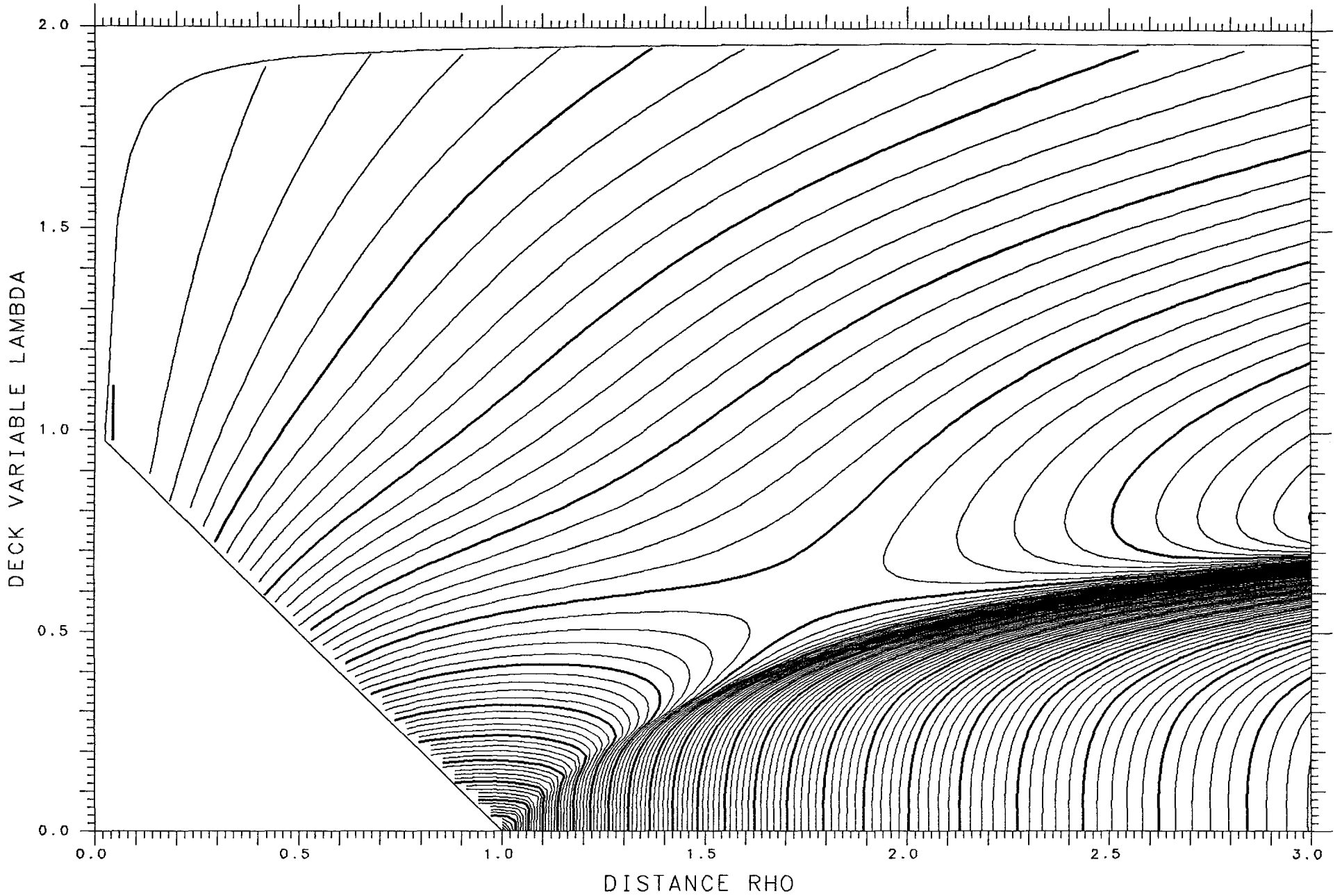

X= .825 ASYMMETRY DELTA= .450 FRACTIONAL= .9483

SPHERES -.02392 TANGENT .07566 LENGTH 10.510 ENERGY 655.09 SPACING .002 SADDLE .05953

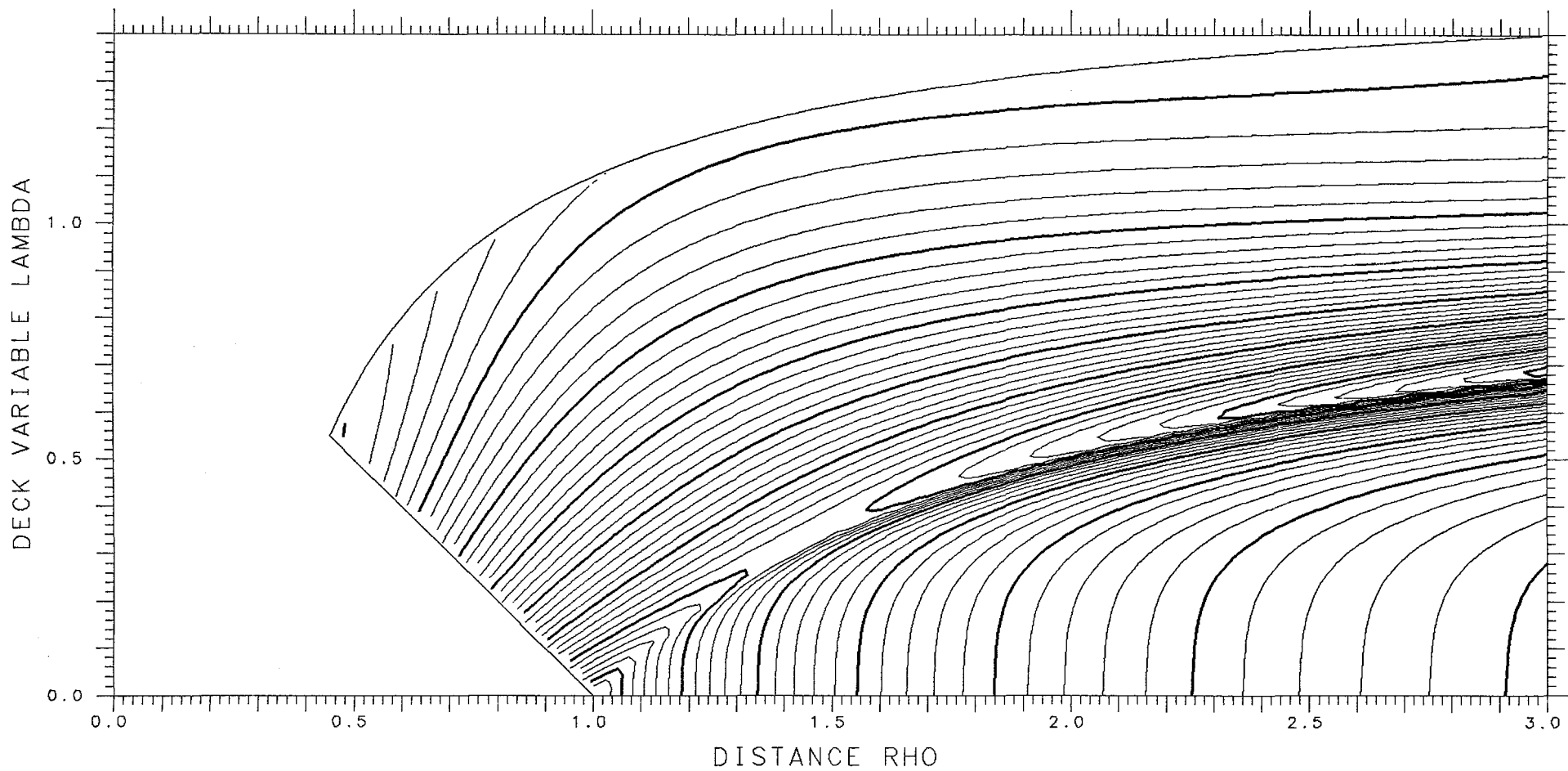

X= .650

ASYMMETRY DELTA= .050

FRACTIONAL= .5745

SPHERES -.21415

TANGENT .12034

LENGTH 11.158

ENERGY 553.46

SPACING .002

SADDLE .04225

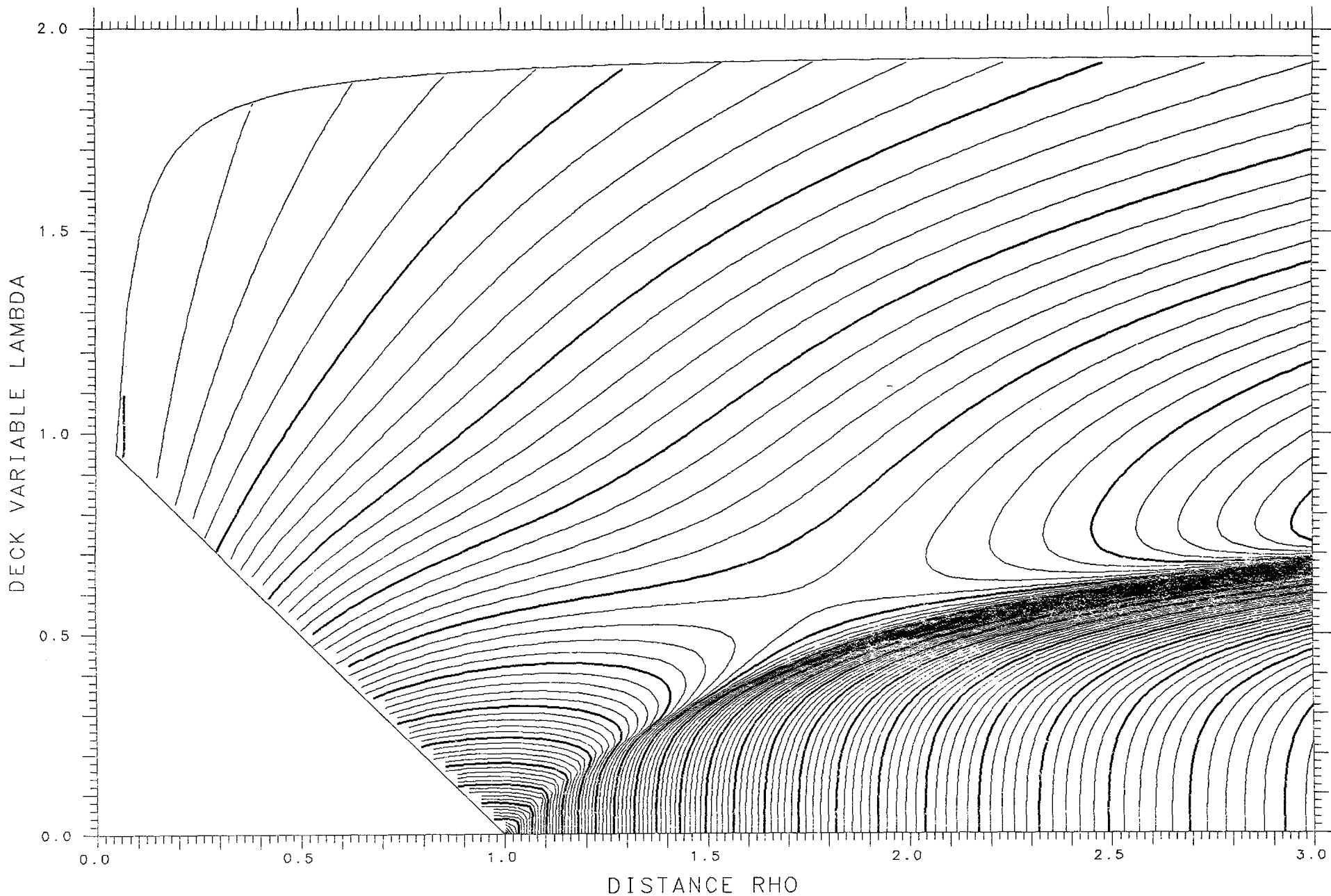

X= .825 ASYMMETRY DELTA= .425 FRACTIONAL= .9384

SPHERES -.03563 TANGENT .08015 LENGTH 10.657 ENERGY 655.09 SPACING .002 SADDLE .05975

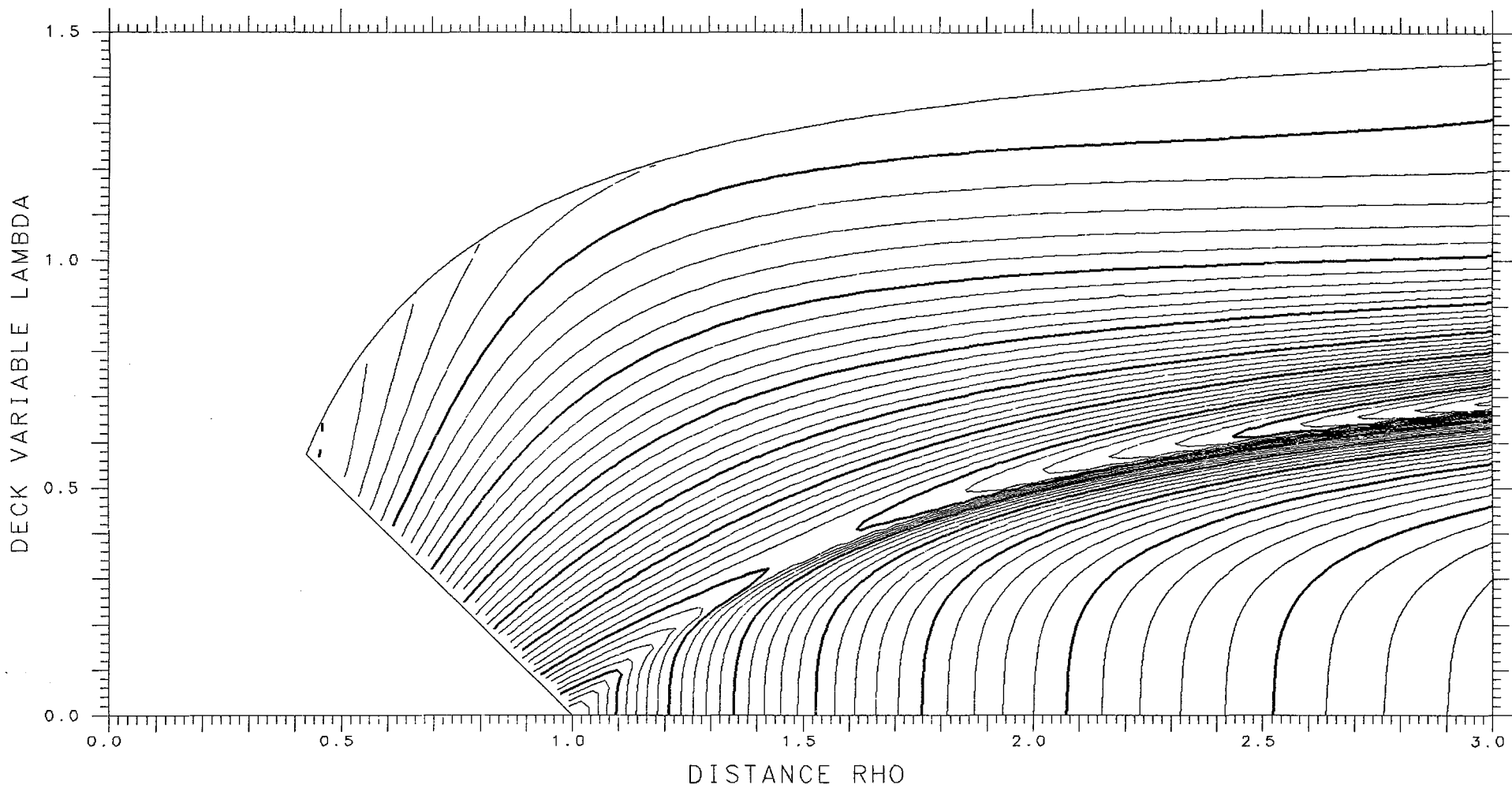

X= .650 ASYMMETRY DELTA= .075 FRACTIONAL= .6108

SPHERES -.20570 TANGENT .12057 LENGTH 11.123 ENERGY 553.46 SPACING .002 SADDLE .04421

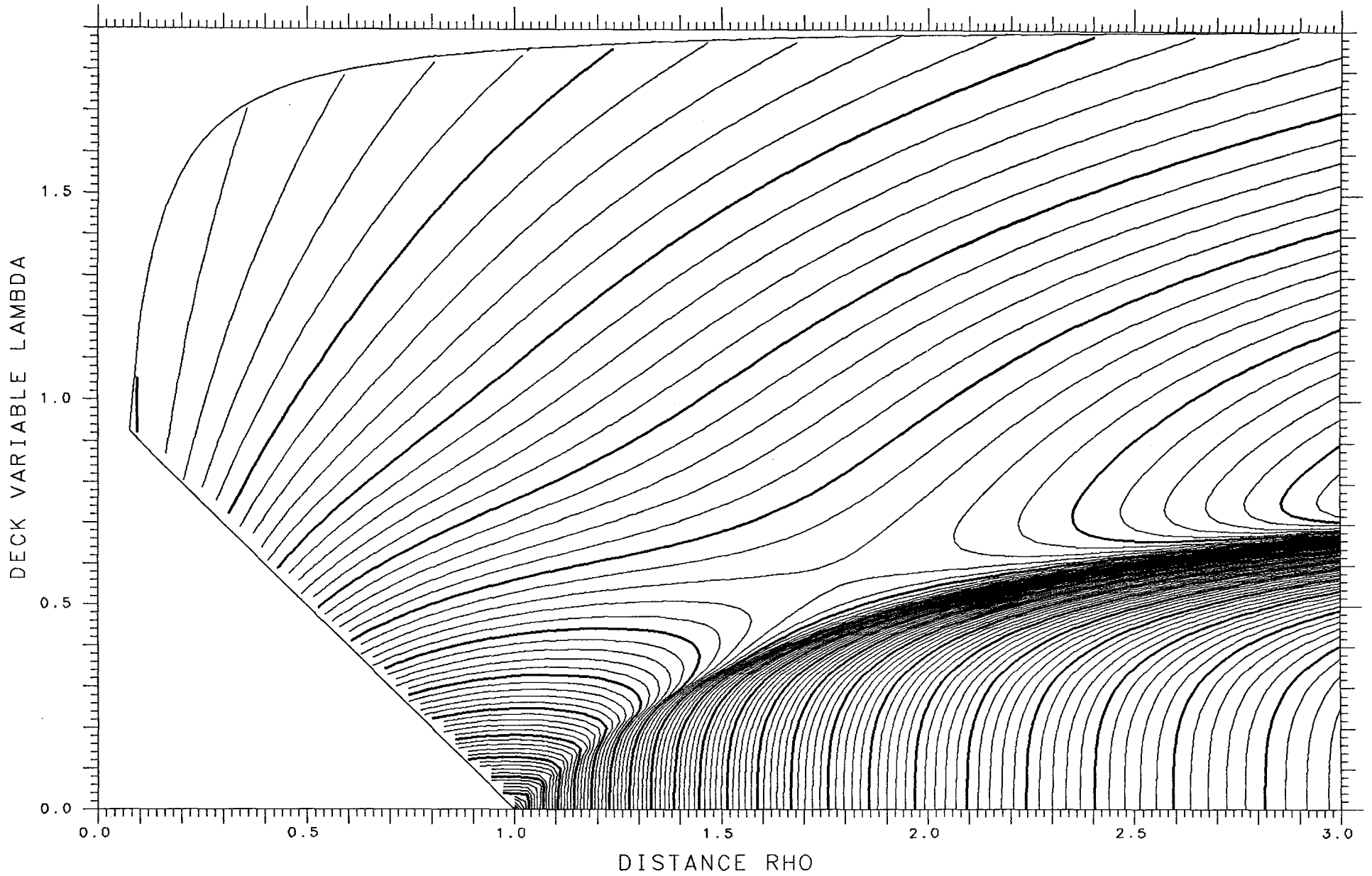

X= .825 ASYMMETRY DELTA= .400 FRACTIONAL= .9270

SPHERES -.04936 TANGENT .08419 LENGTH 10.803 ENERGY 655.09 SPACING .002 SADDLE .05876

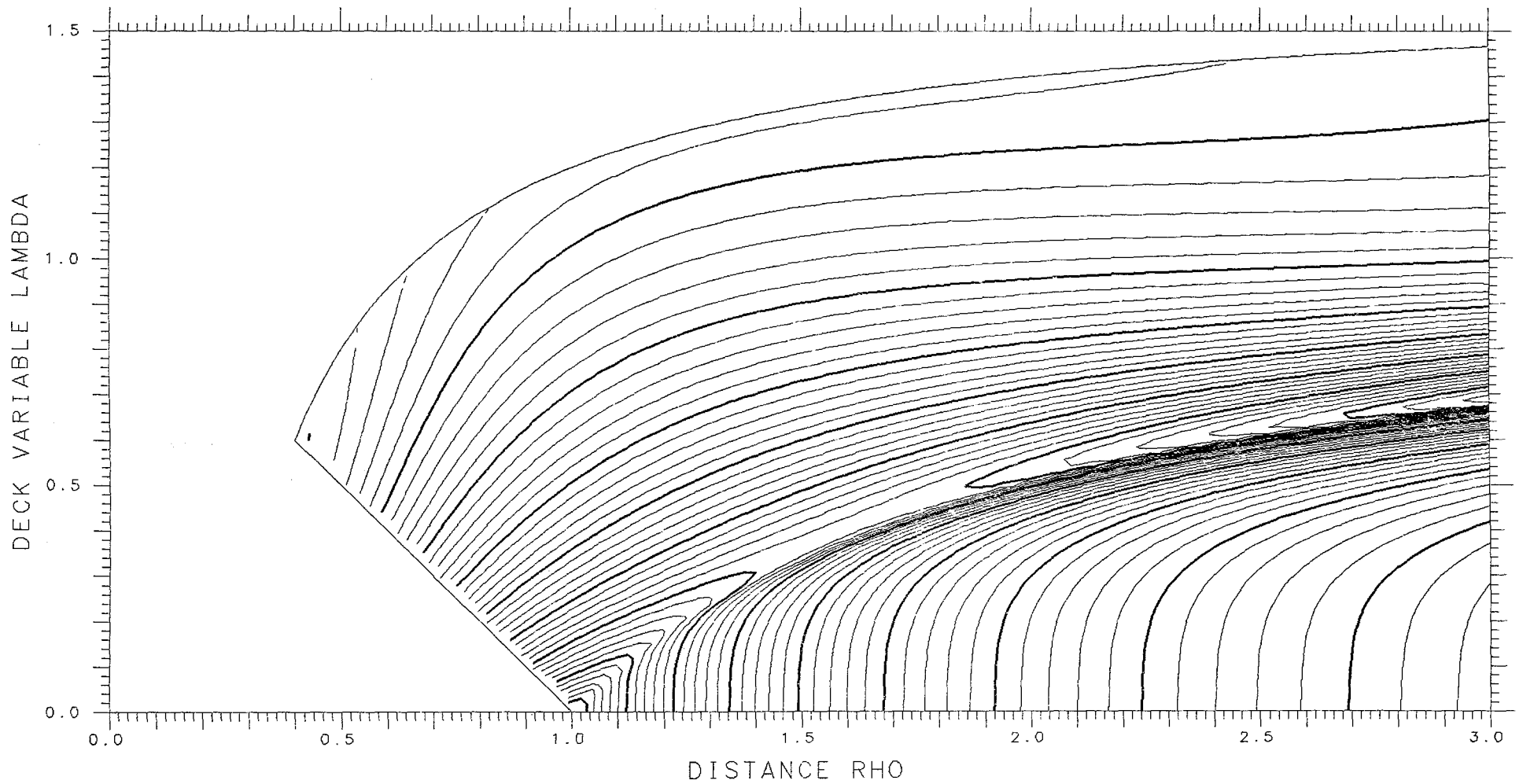

X= .650 ASYMMETRY DELTA= .100 FRACTIONAL= .6461

SPHERES -.19438 TANGENT .12080 LENGTH 11.076 ENERGY 553.46 SPACING .002 SADDLE .04695

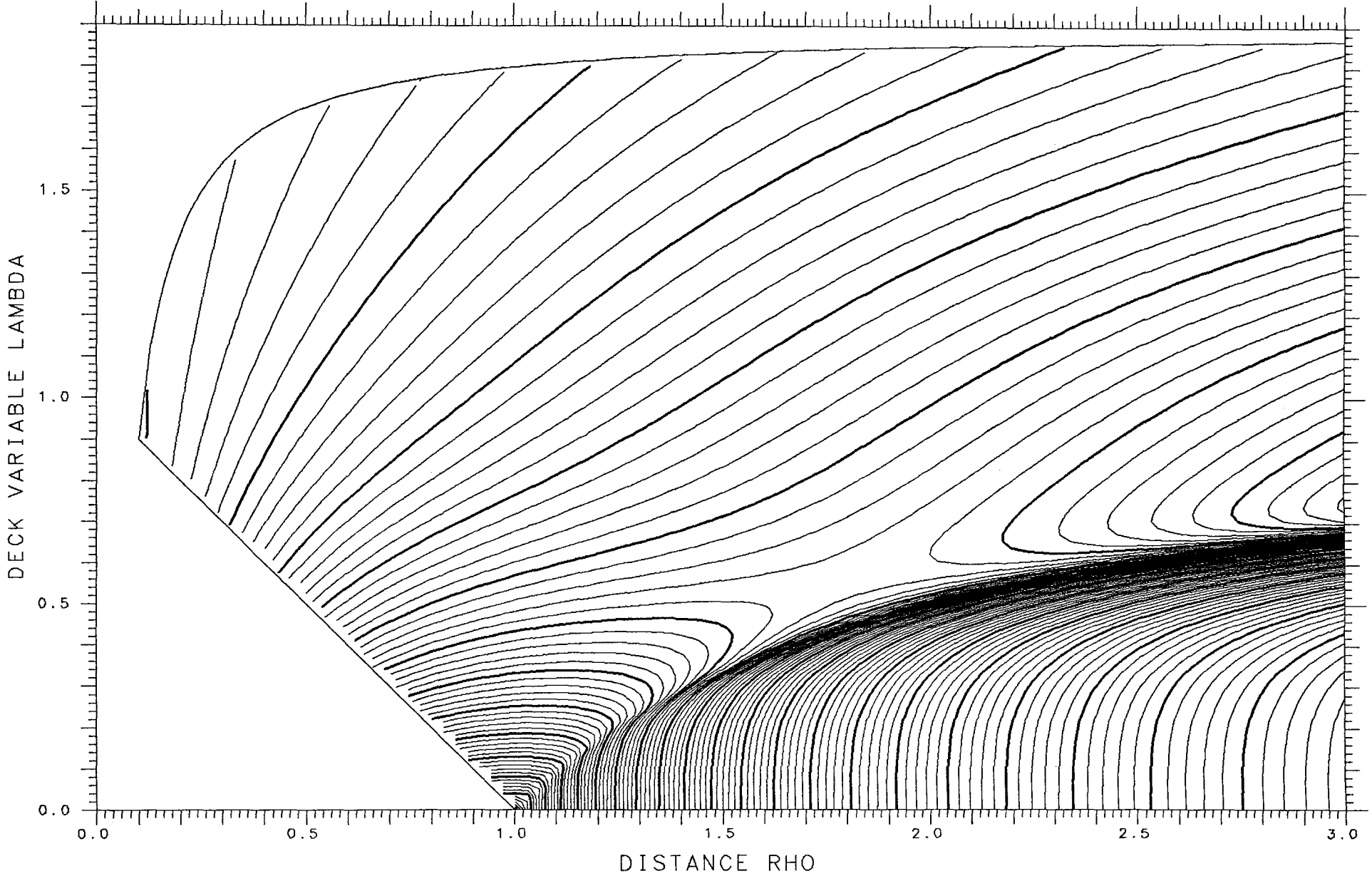

X= .825 ASYMMETRY DELTA= .375 FRACTIONAL= .9141

SPHERES -.06518 TANGENT .08771 LENGTH 10.948 ENERGY 655.09 SPACING .002 SADDLE .05641

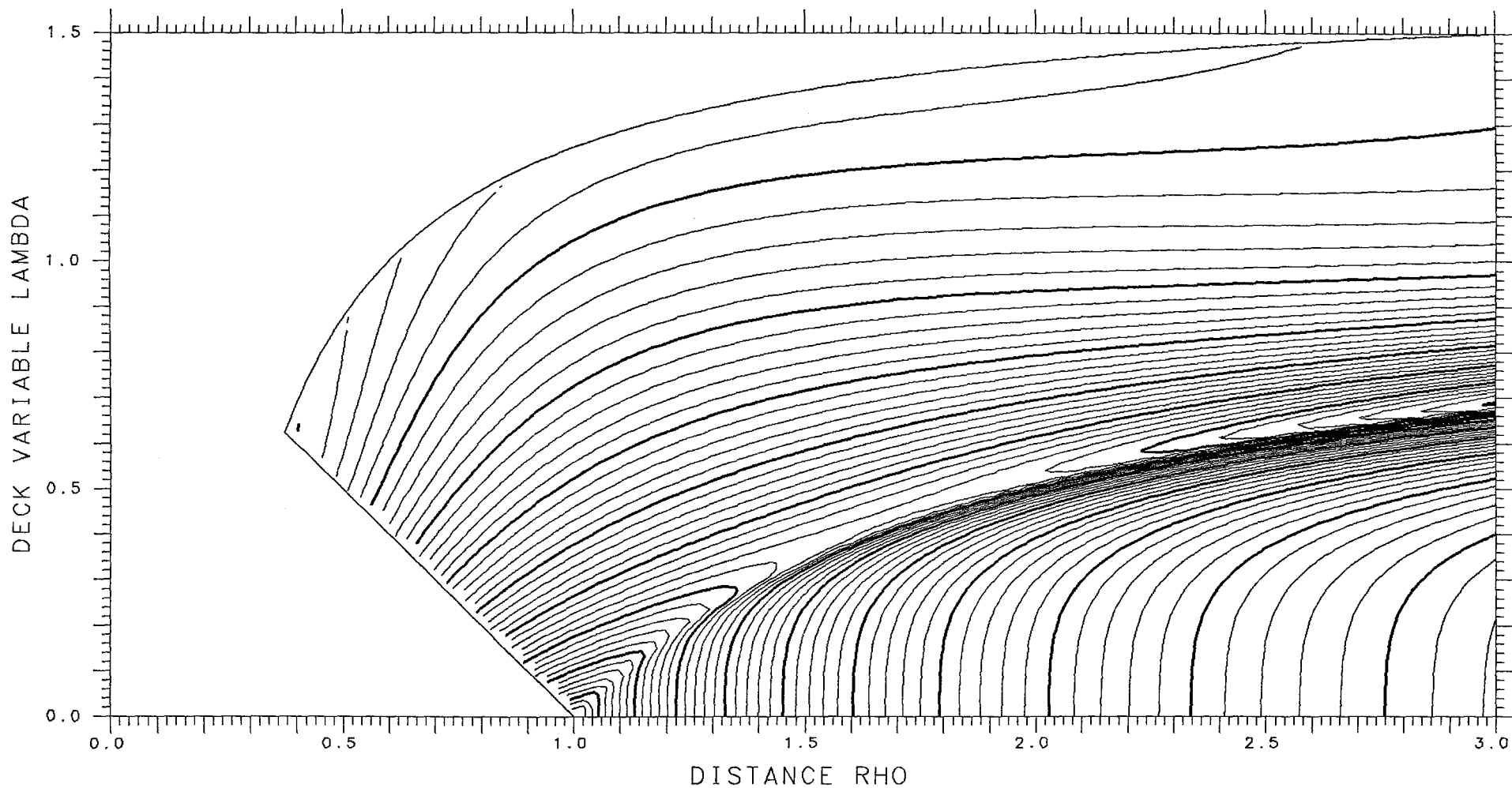

X= .650

ASYMMETRY DELTA= .125

FRACTIONAL= .6800

SPHERES -.18065

TANGENT .12091

LENGTH 11.016

ENERGY 553.46

SPACING .002

SADDLE .05040

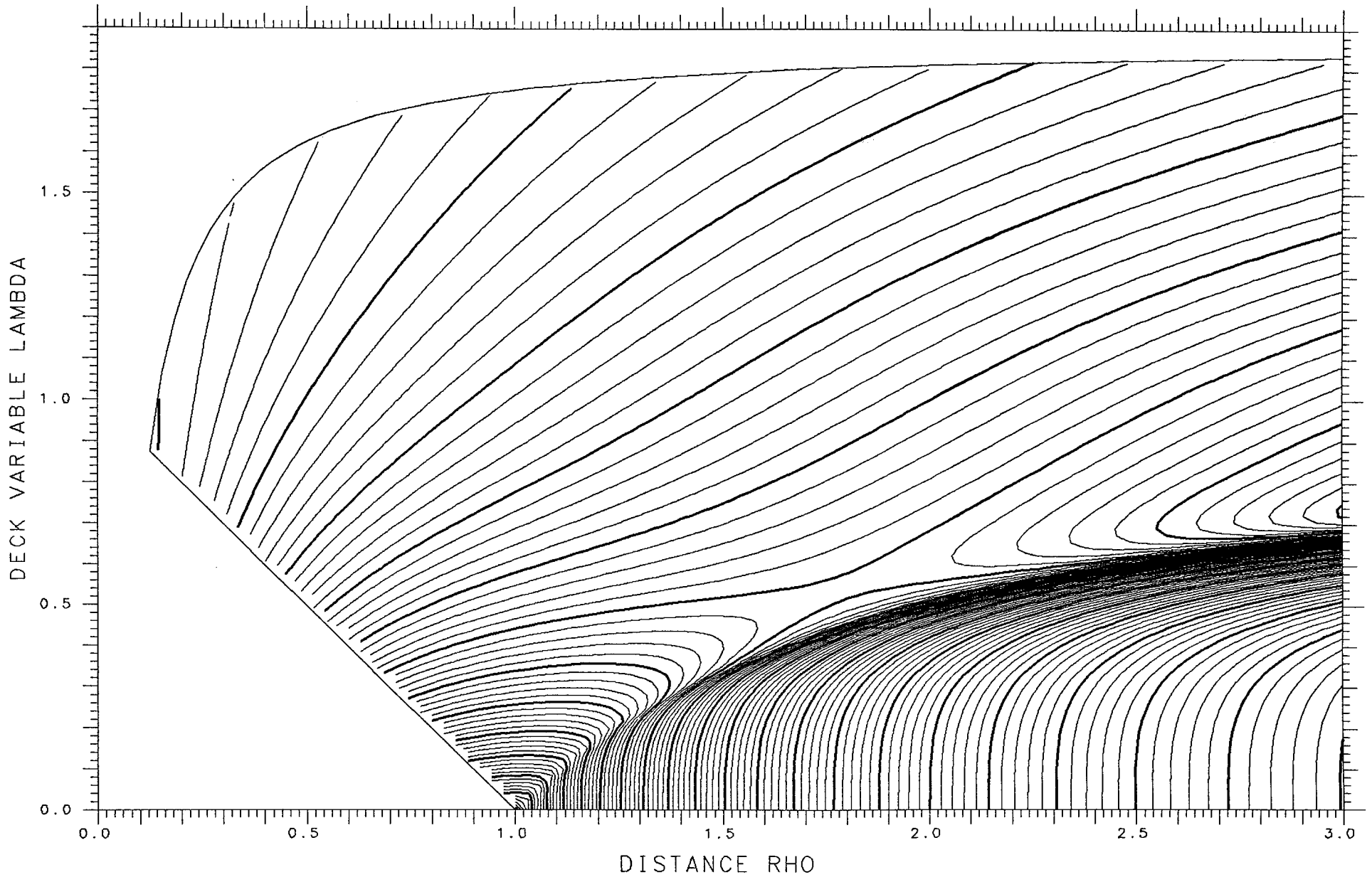

X = .825 ASYMMETRY DELTA = .350 FRACTIONAL = .8996

SPHERES - .08307 TANGENT .09062 LENGTH 11.092 ENERGY 655.09 SPACING .002 SADDLE .05264

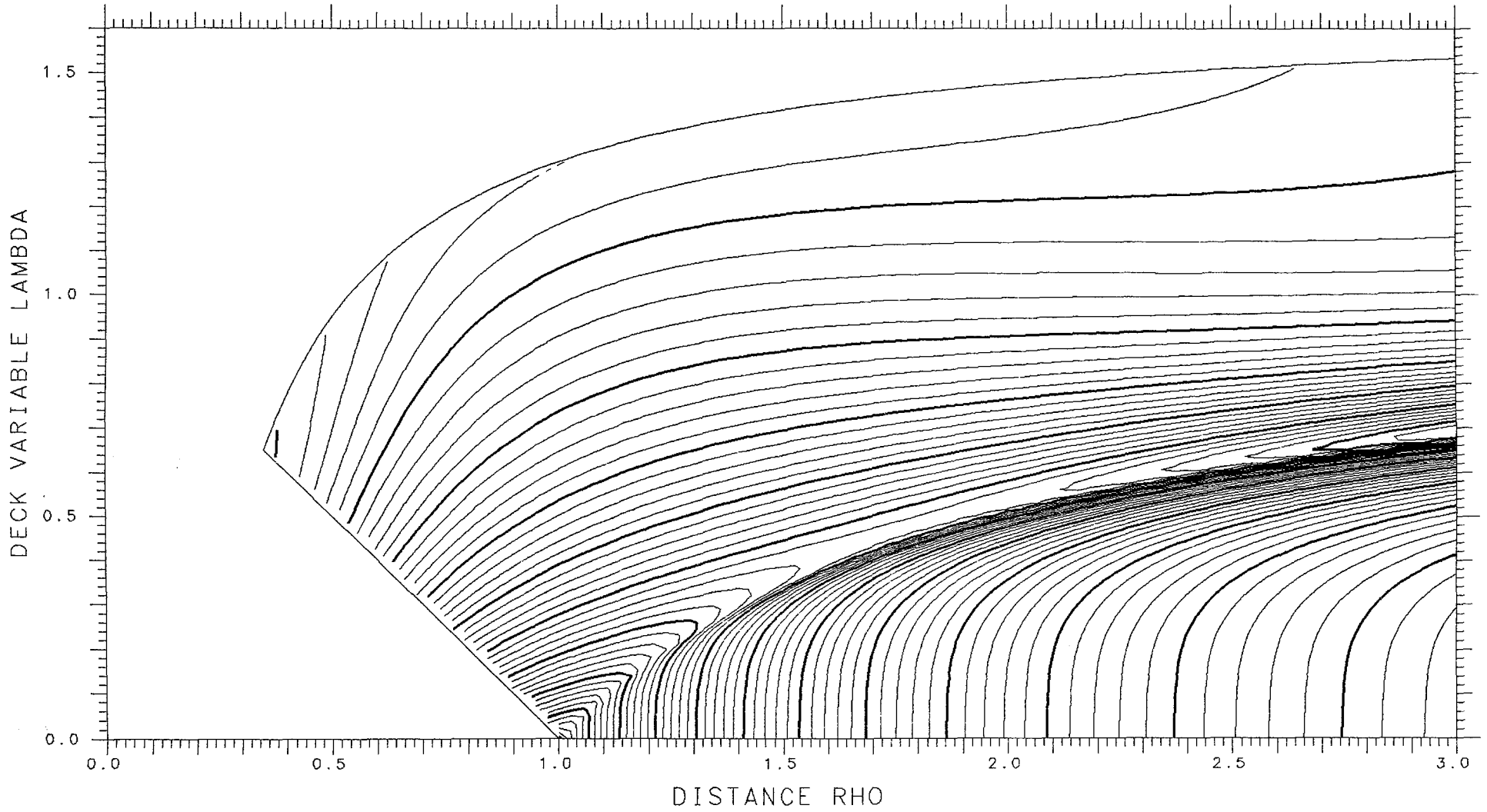

X= .650 ASYMMETRY DELTA= .150 FRACTIONAL= .7124

SPHERES -.16504 TANGENT .12080 LENGTH 10.945 ENERGY 553.46 SPACING .002 SADDLE .05441

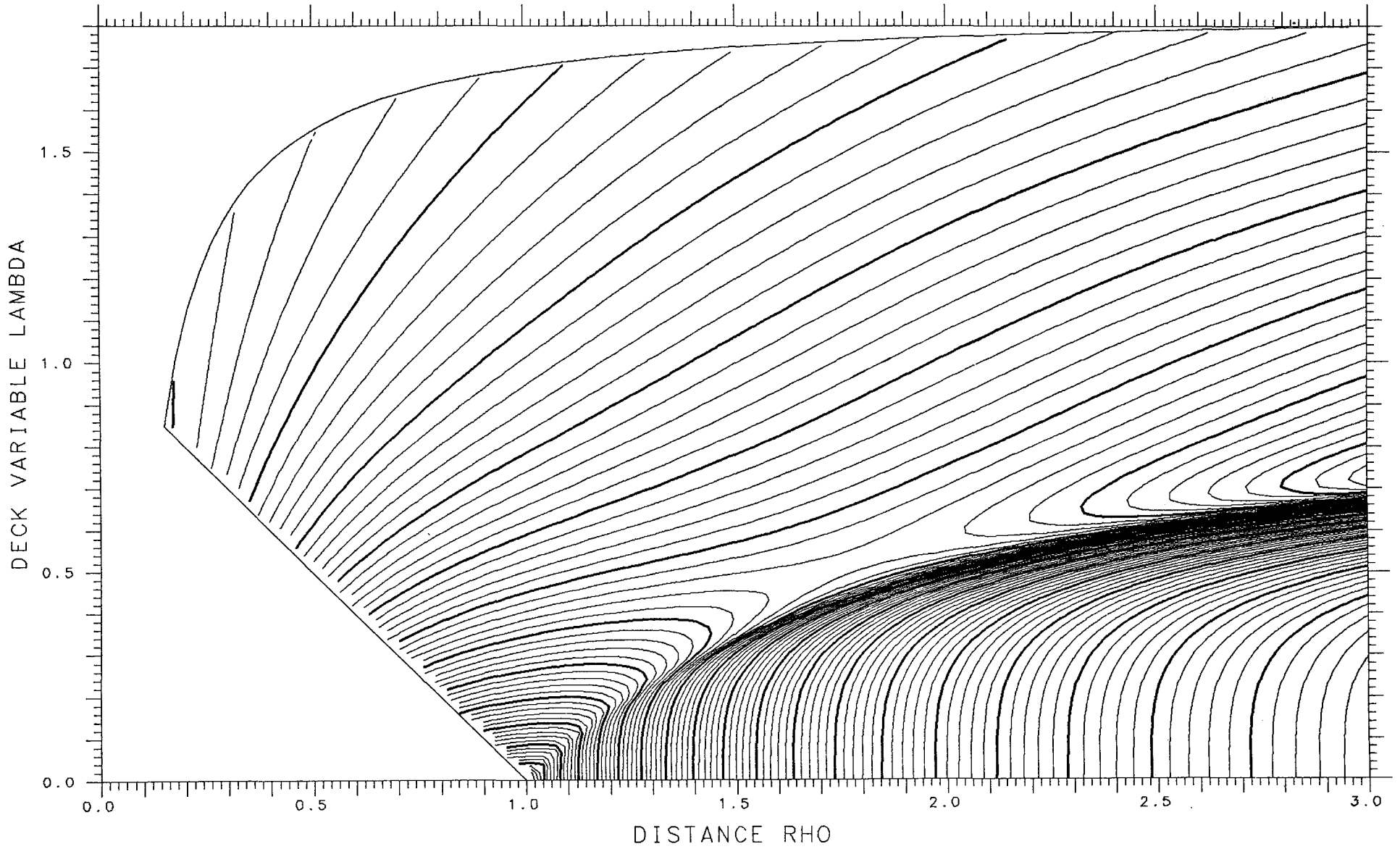

X= .825 ASYMMETRY DELTA= .325 FRACTIONAL= .8832

SPHERES -.10297 TANGENT .09288 LENGTH 11.232 ENERGY 655.09 SPACING .002 SADDLE .04743

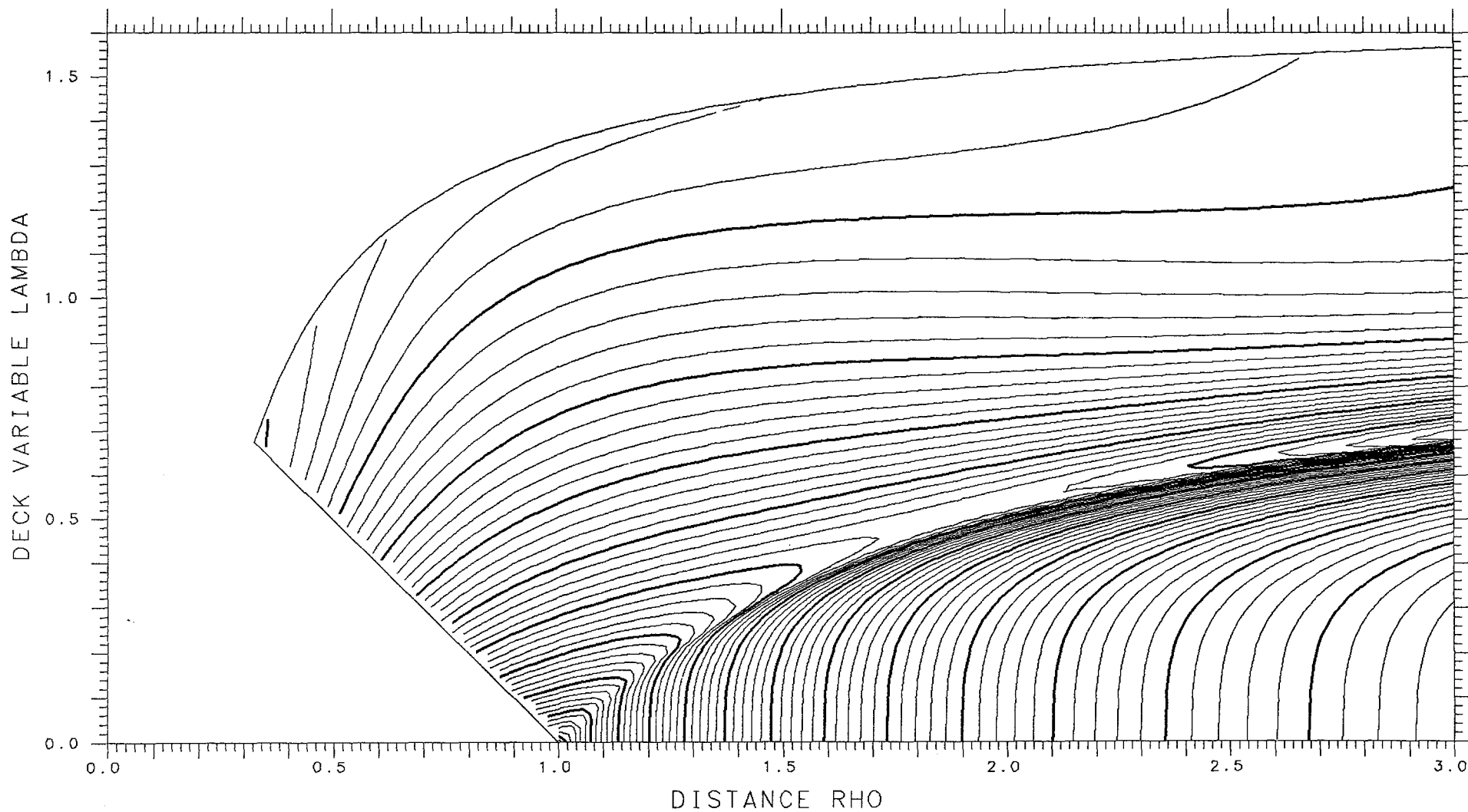

X= .650 ASYMMETRY DELTA= .175 FRACTIONAL= .7429

SPHERES -.14810 TANGENT .12037 LENGTH 10.863 ENERGY 553.46 SPACING .002 SADDLE .05876

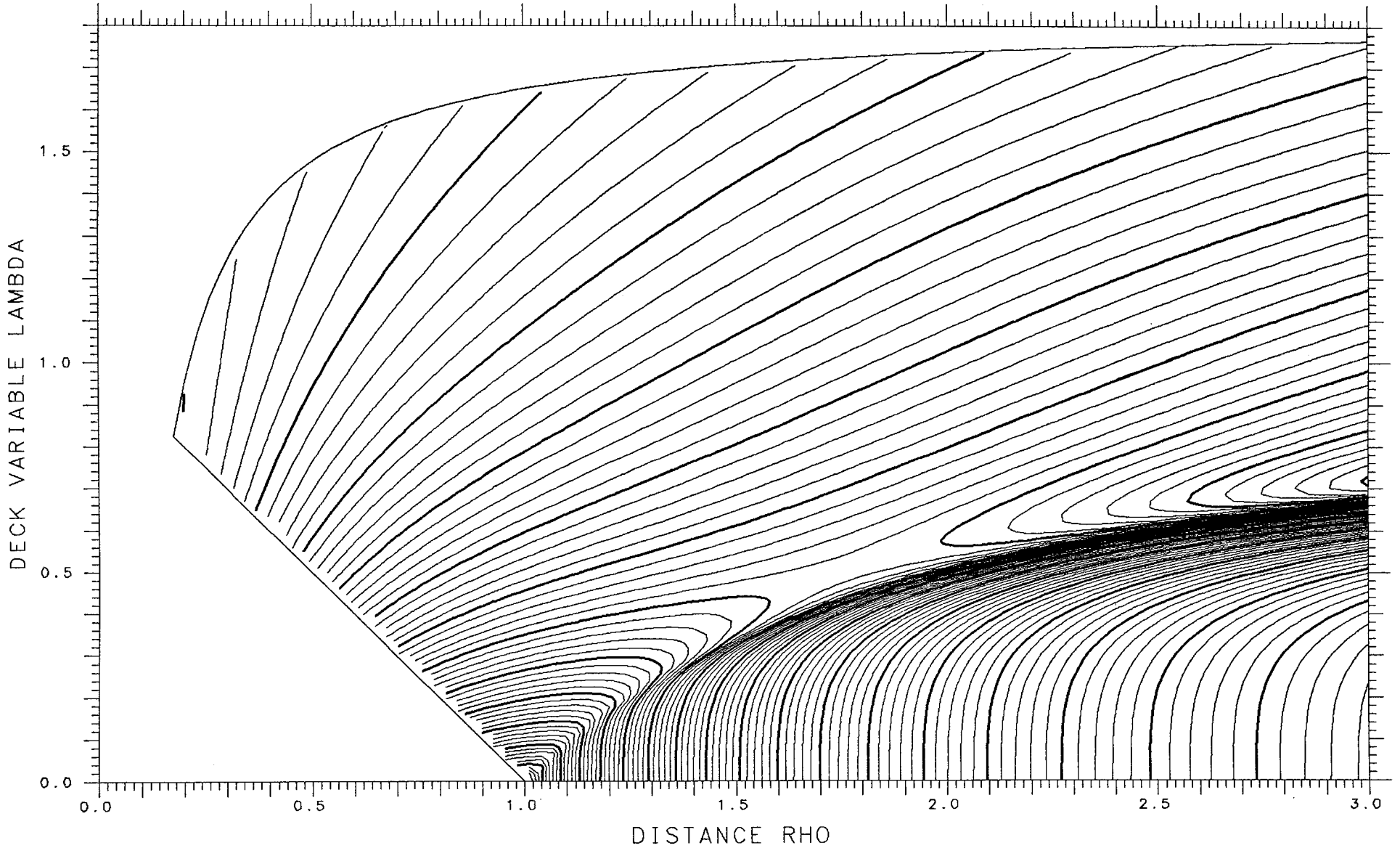

X= .825 ASYMMETRY DELTA= .300 FRACTIONAL= .8650

SPHERES -.12470 TANGENT .09443 LENGTH 11.368 ENERGY 655.09 SPACING .002 SADDLE .04088

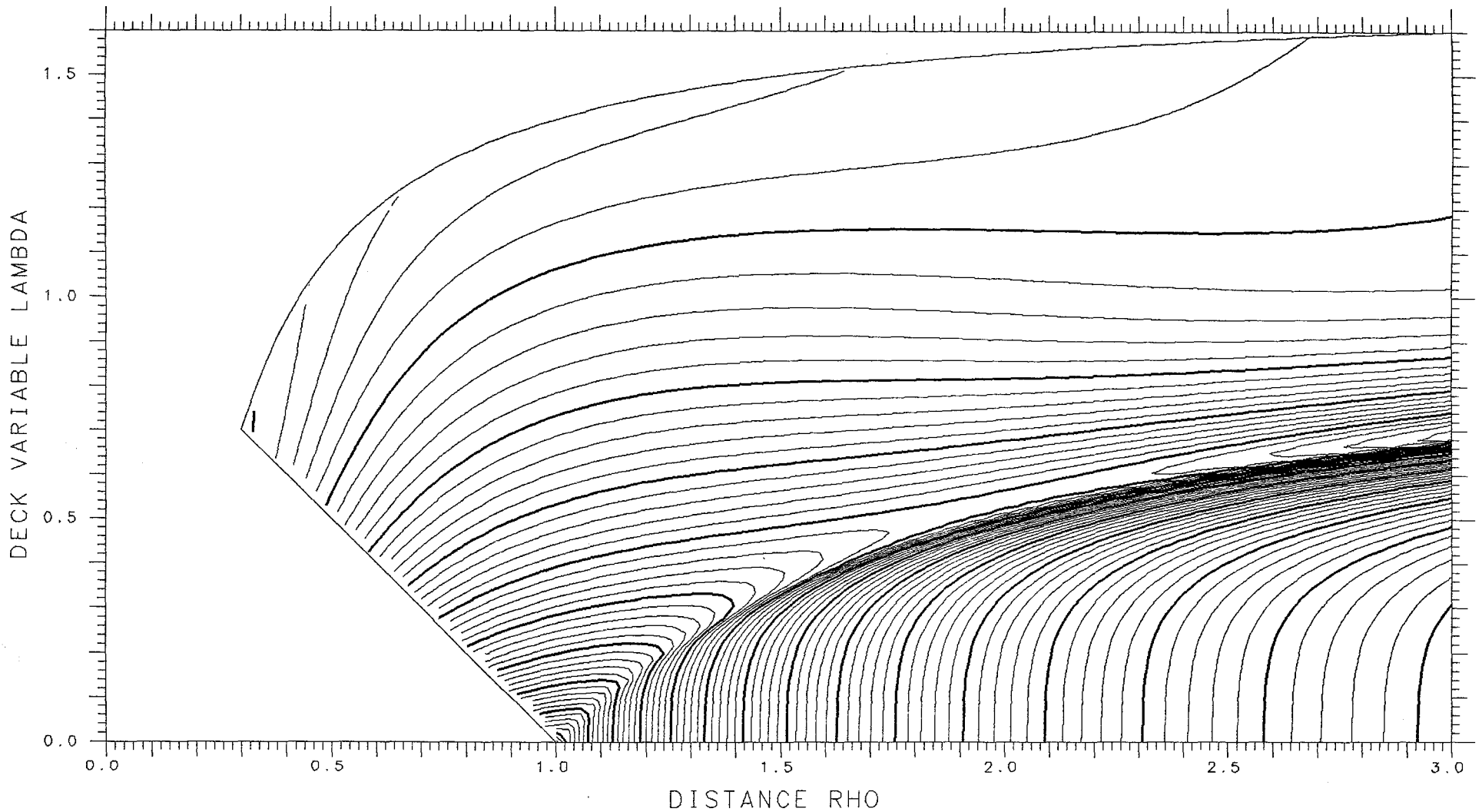

X= .650 ASYMMETRY DELTA= .200 FRACTIONAL= .7714

SPHERES -.13042 TANGENT .11952 LENGTH 10.771 ENERGY 553.46 SPACING .002 SADDLE .06318

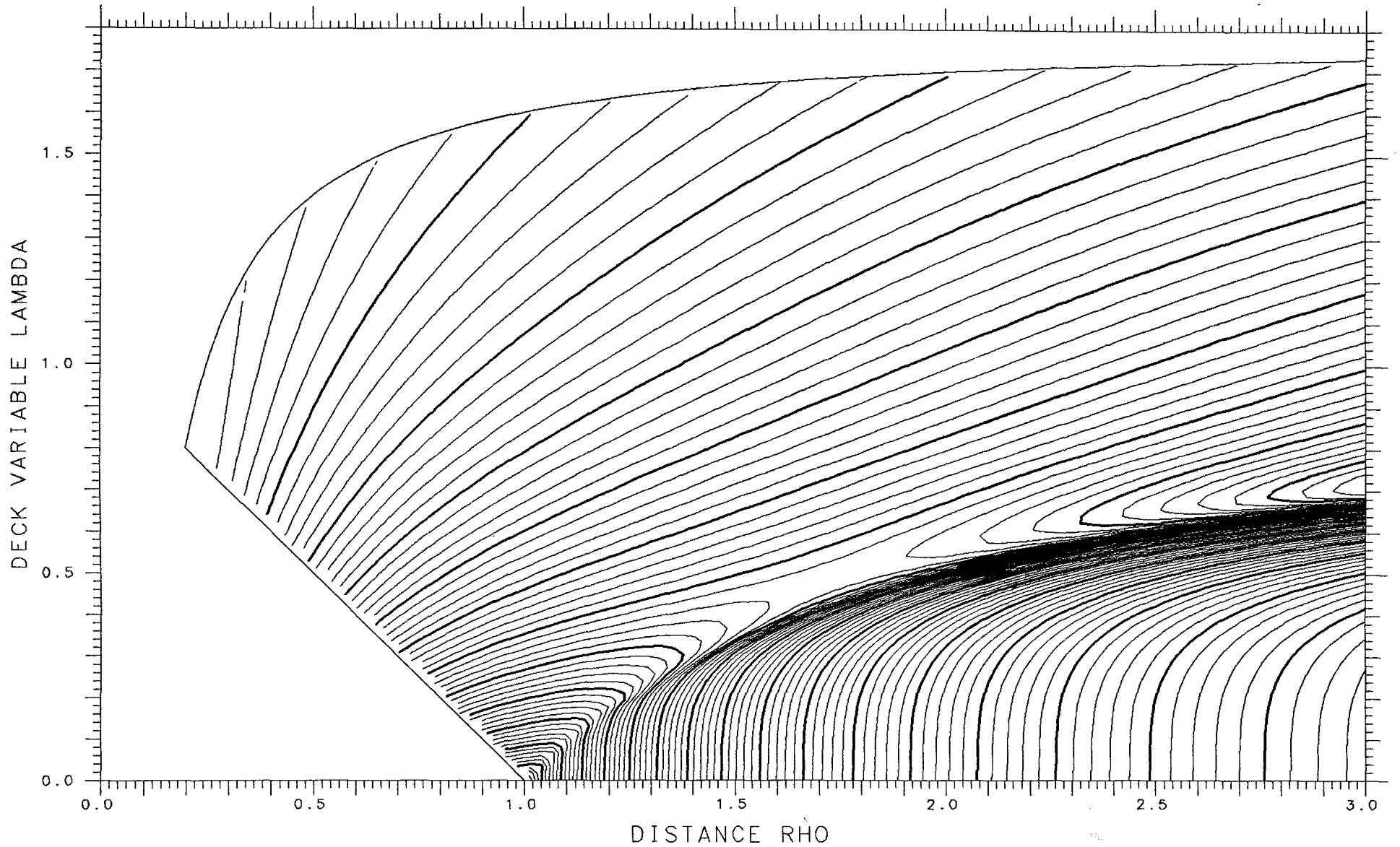

X= .825 ASYMMETRY DELTA= .275 FRACTIONAL= .8447

SPHERES -.14803 TANGENT .09526 LENGTH 11.500 ENERGY 655.09 SPACING .002 SADDLE .03315

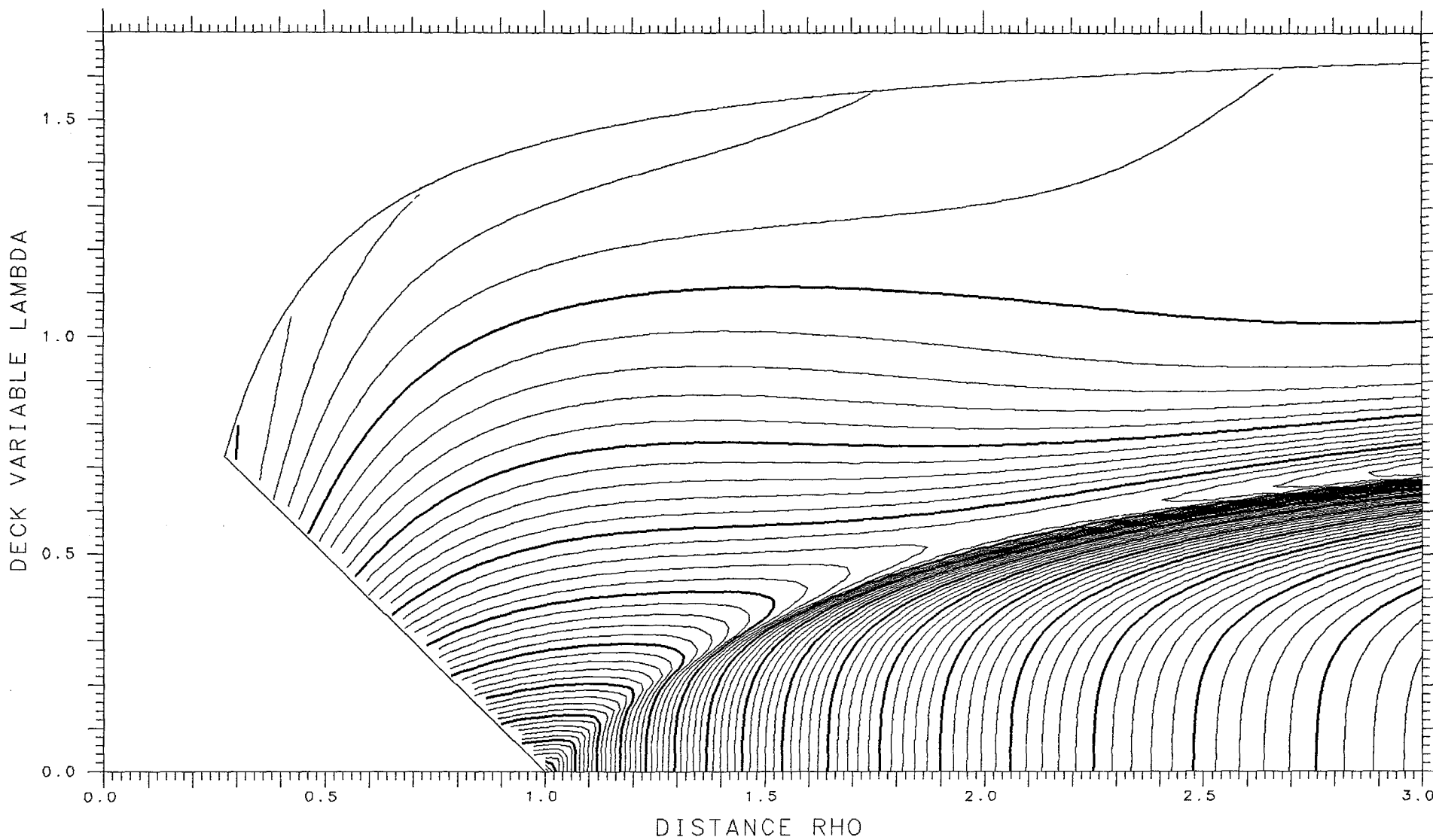

X= .650 ASYMMETRY DELTA= .225 FRACTIONAL= .7979

SPHERES -.11251 TANGENT .11817 LENGTH 10.671 ENERGY 553.46 SPACING .002 SADDLE .06740

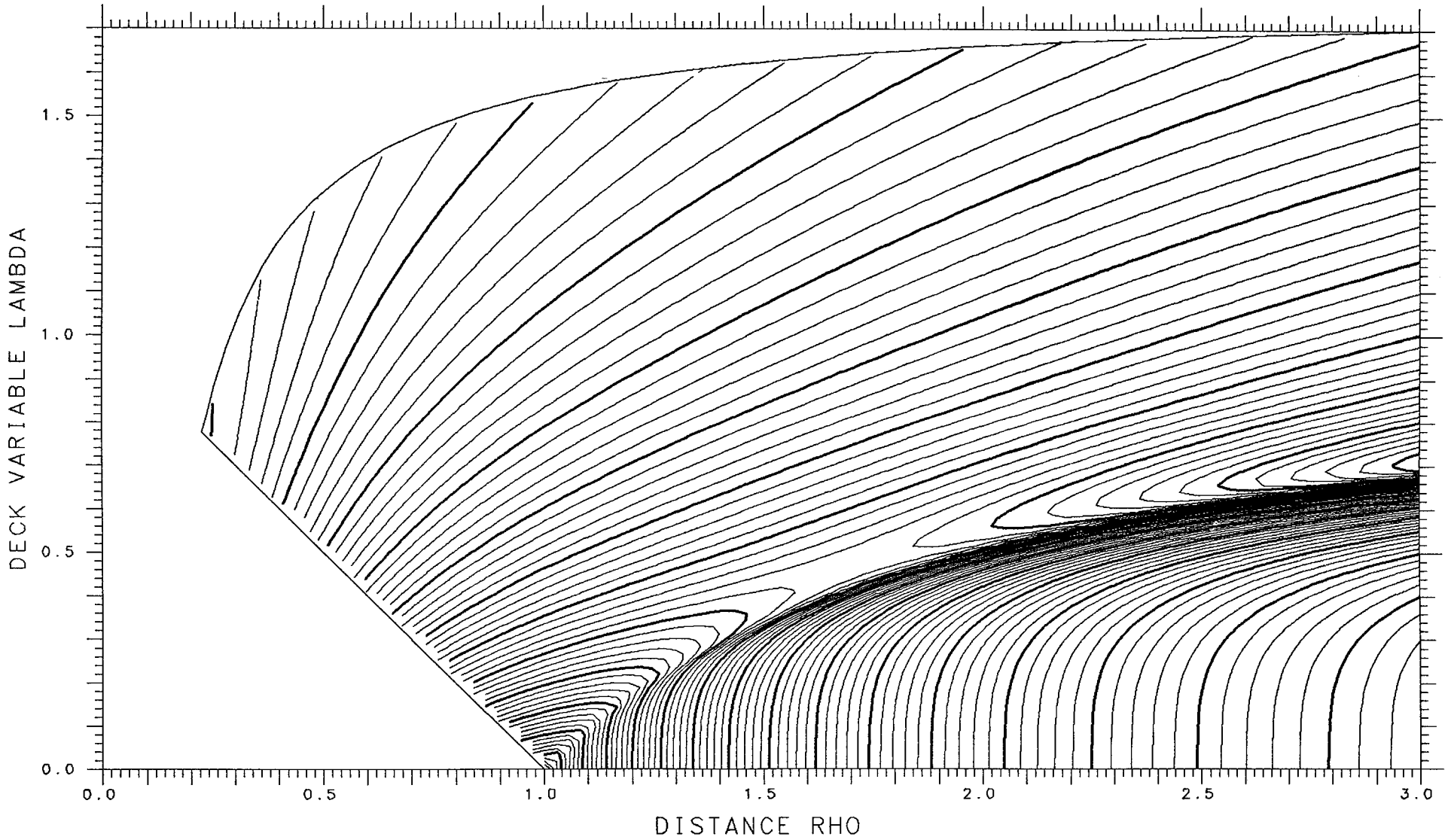

X= .825 ASYMMETRY DELTA= .250 FRACTIONAL= .8224

SPHERES -.17258 TANGENT .09540 LENGTH 11.626 ENERGY 655.09 SPACING .002 SADDLE .02449

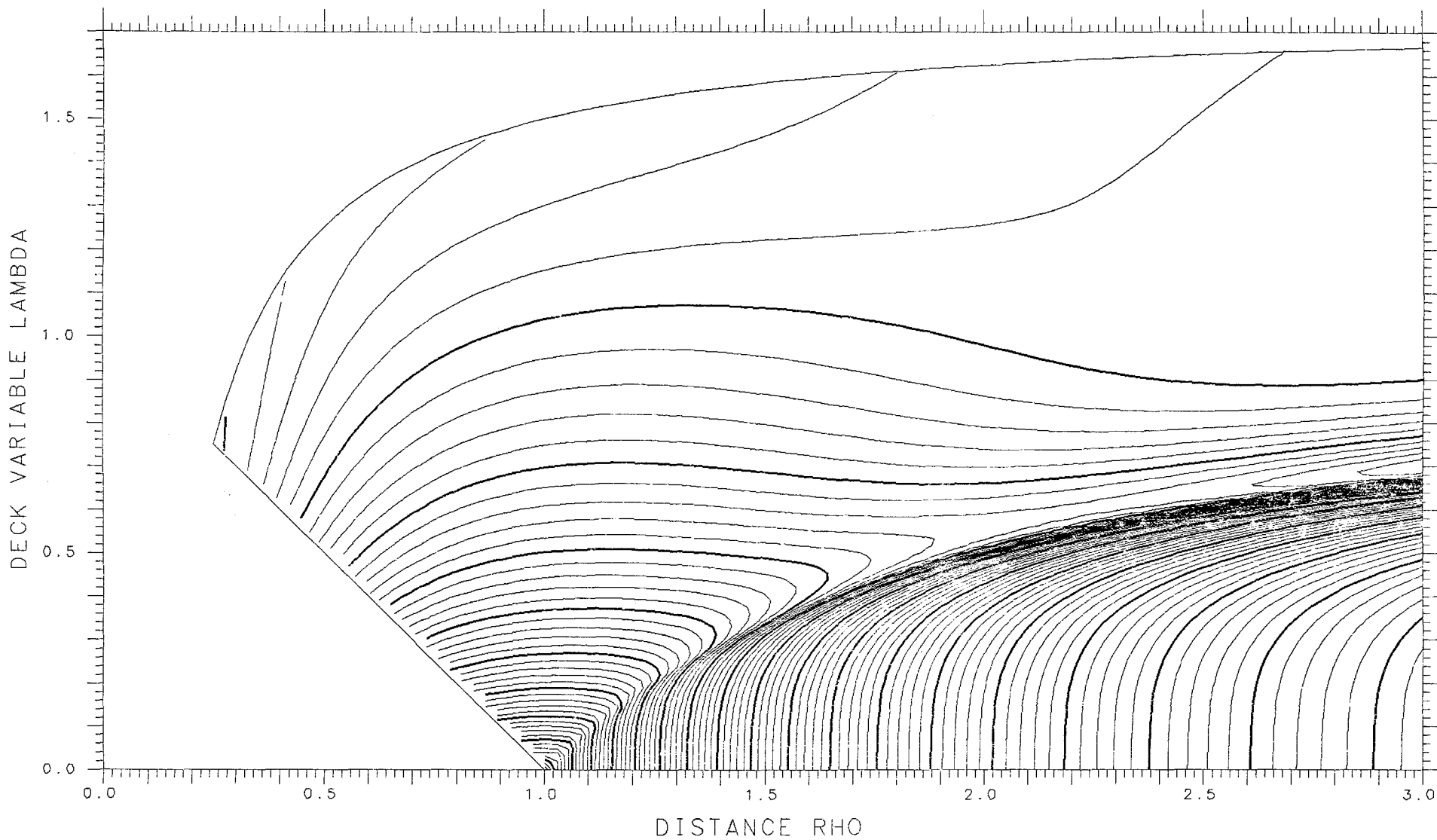

X= .650

ASYMMETRY DELTA= .250

FRACTIONAL= .8224

SPHERES -.09487

TANGENT .11627

LENGTH 10.563

ENERGY 553.46

SPACING .002

SADDLE .07118

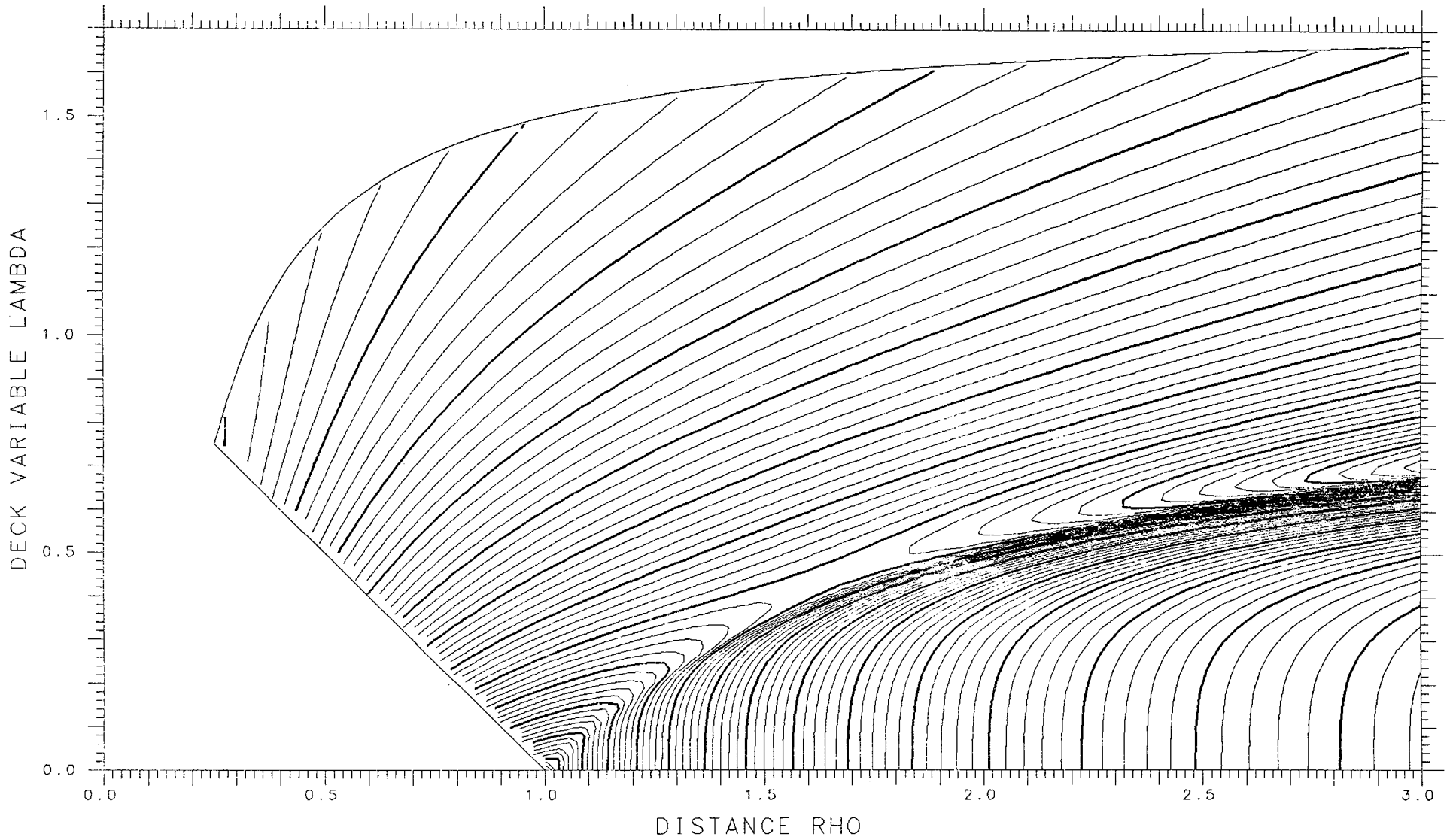

X= .825 ASYMMETRY DELTA= .225 FRACTIONAL= .7979

SPHERES -.19790 TANGENT .09490 LENGTH 11.744 ENERGY 655.09 SPACING .002 SADDLE .01527

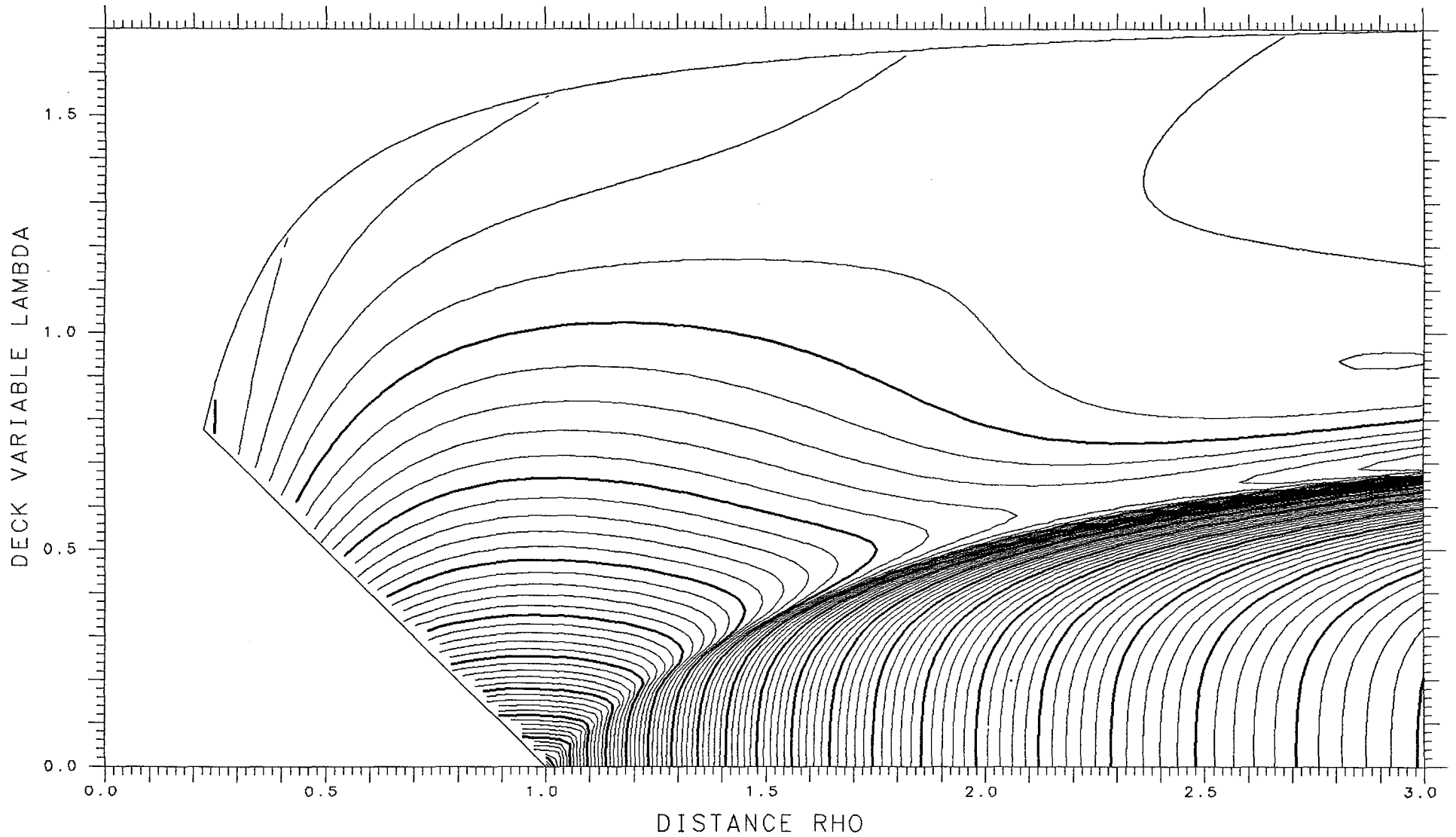

X= .650 ASYMMETRY DELTA= .275 FRACTIONAL= .8447

SPHERES -.07791 TANGENT .11377 LENGTH 10.449 ENERGY 553.46 SPACING .002 SADDLE .07431

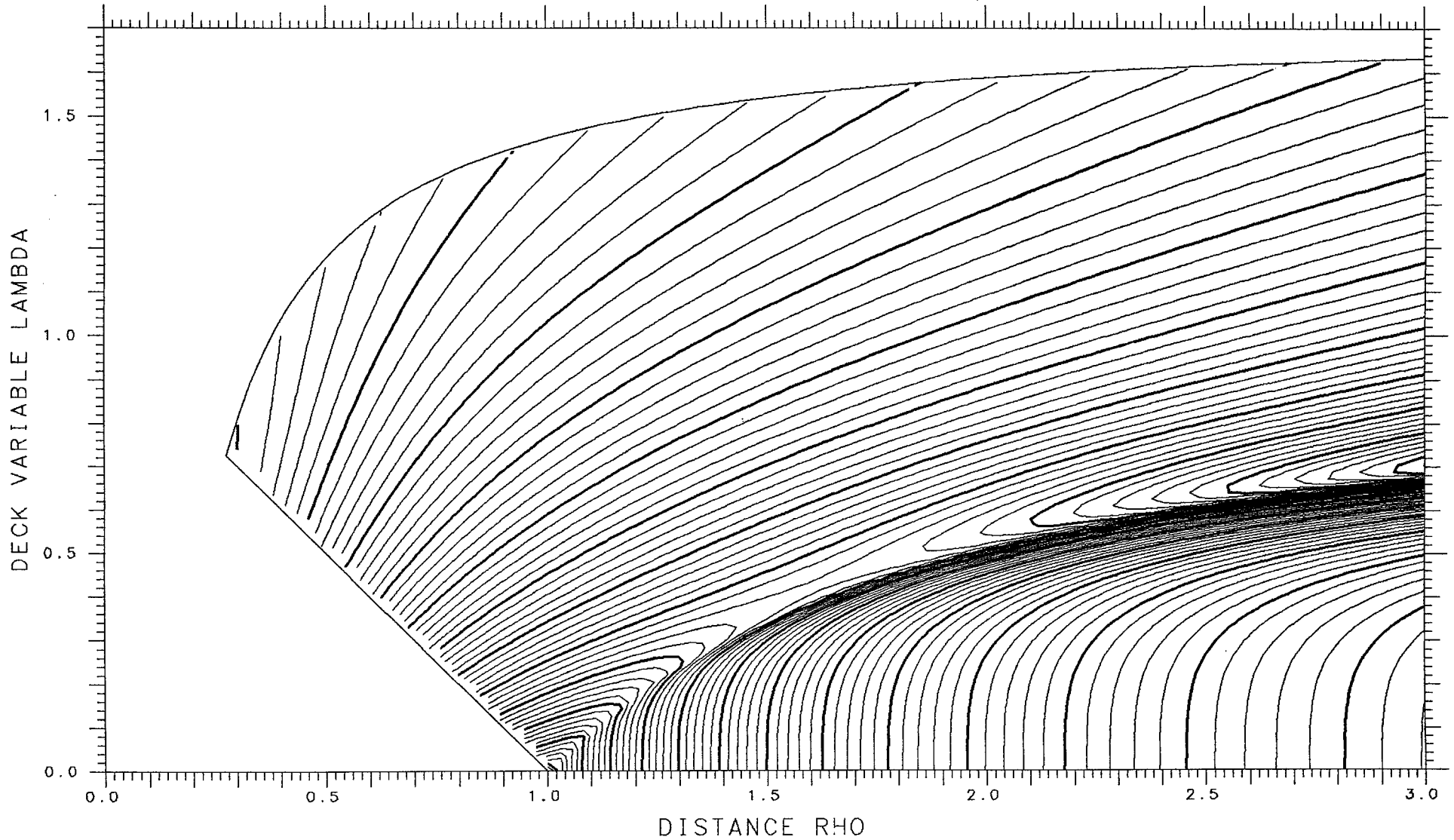

X= .825 ASYMMETRY DELTA= .200 FRACTIONAL= .7714

SPHERES -.22340 TANGENT .09382 LENGTH 11.855 ENERGY 655.09 SPACING .002 SADDLE .00595

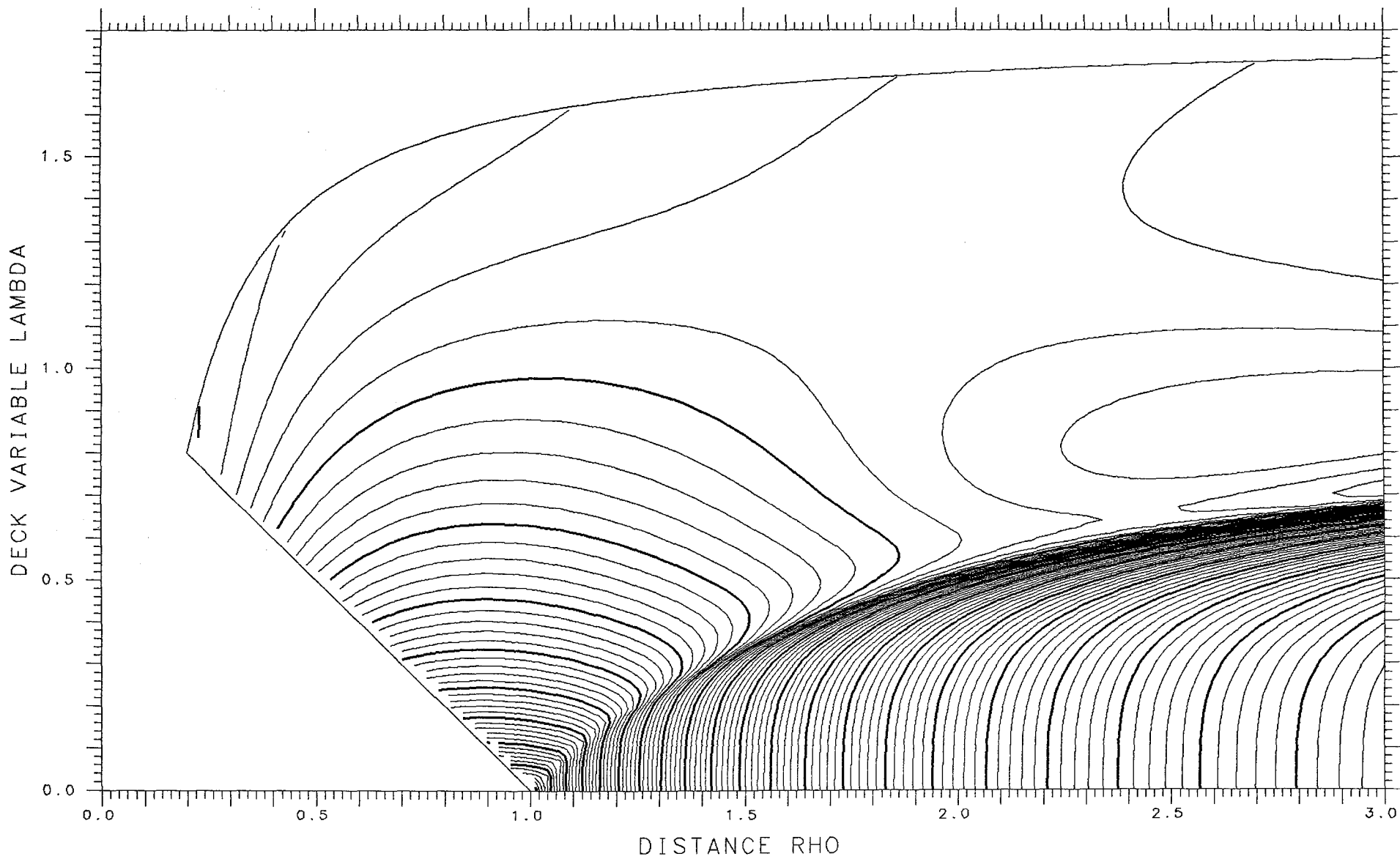

X= .650 ASYMMETRY DELTA= .300 FRACTIONAL= .8650

SPHERES -.06197 TANGENT .11068 LENGTH 10.329 ENERGY 553.46 SPACING .002 SADDLE .07662

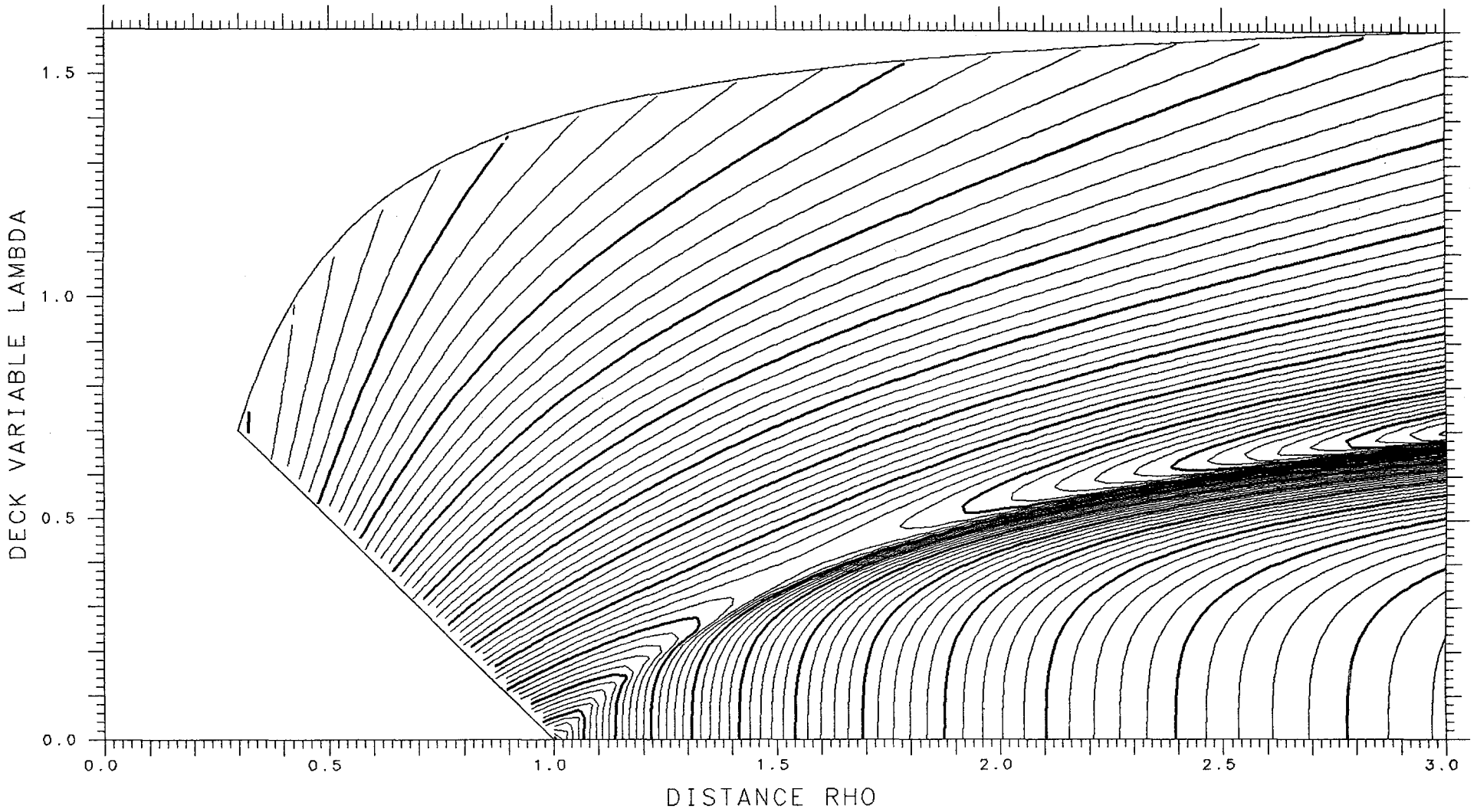

X= .825 ASYMMETRY DELTA= .175 FRACTIONAL= .7429

SPHERES -.24845 TANGENT .09231 LENGTH 11.956 ENERGY 655.09 SPACING .002 SADDLE -.00281

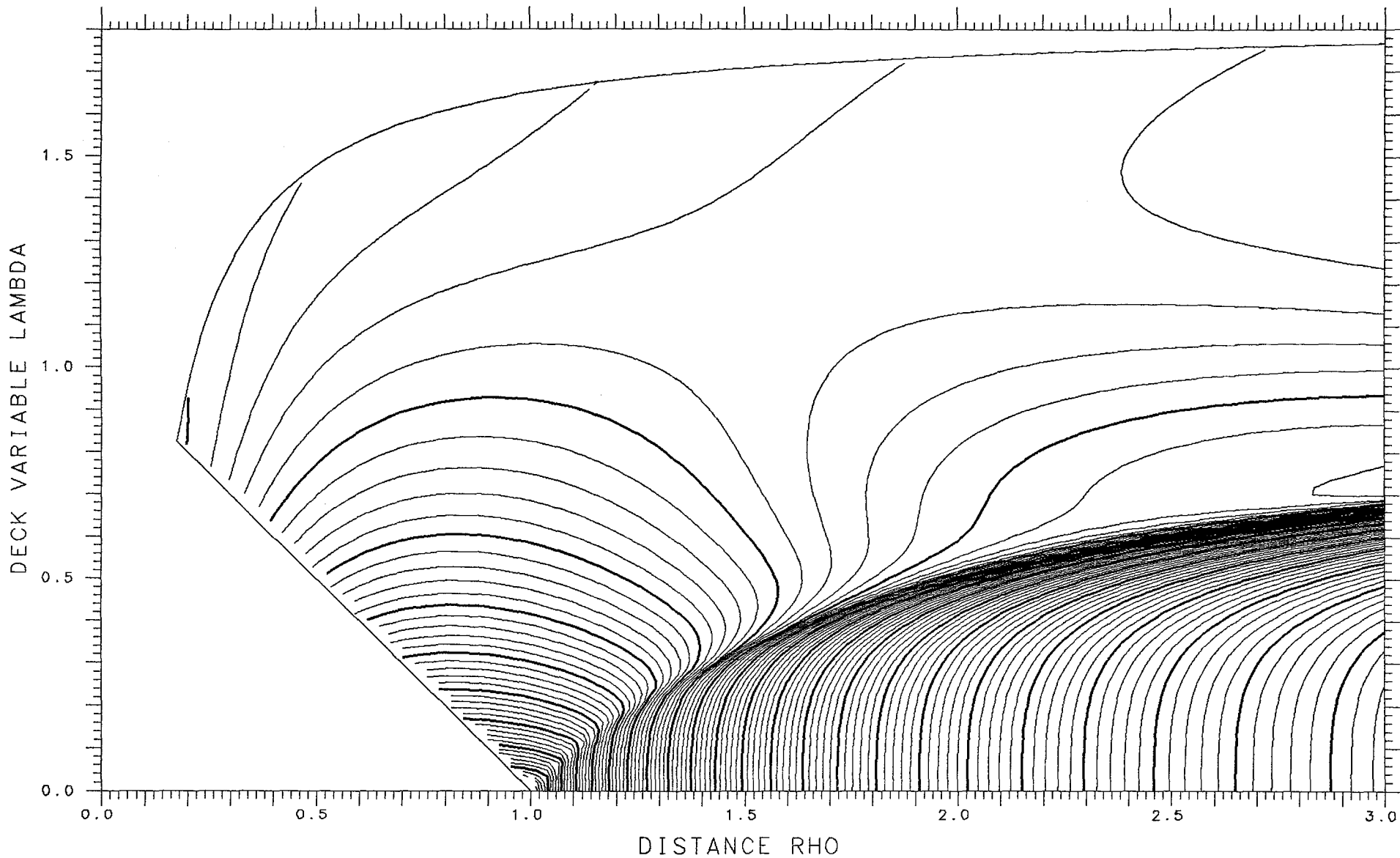

X= .650 ASYMMETRY DELTA= .325 FRACTIONAL= .8832

SPHERES -.04730 TANGENT .10700 LENGTH 10.205 ENERGY 553.46 SPACING .002 SADDLE .07802

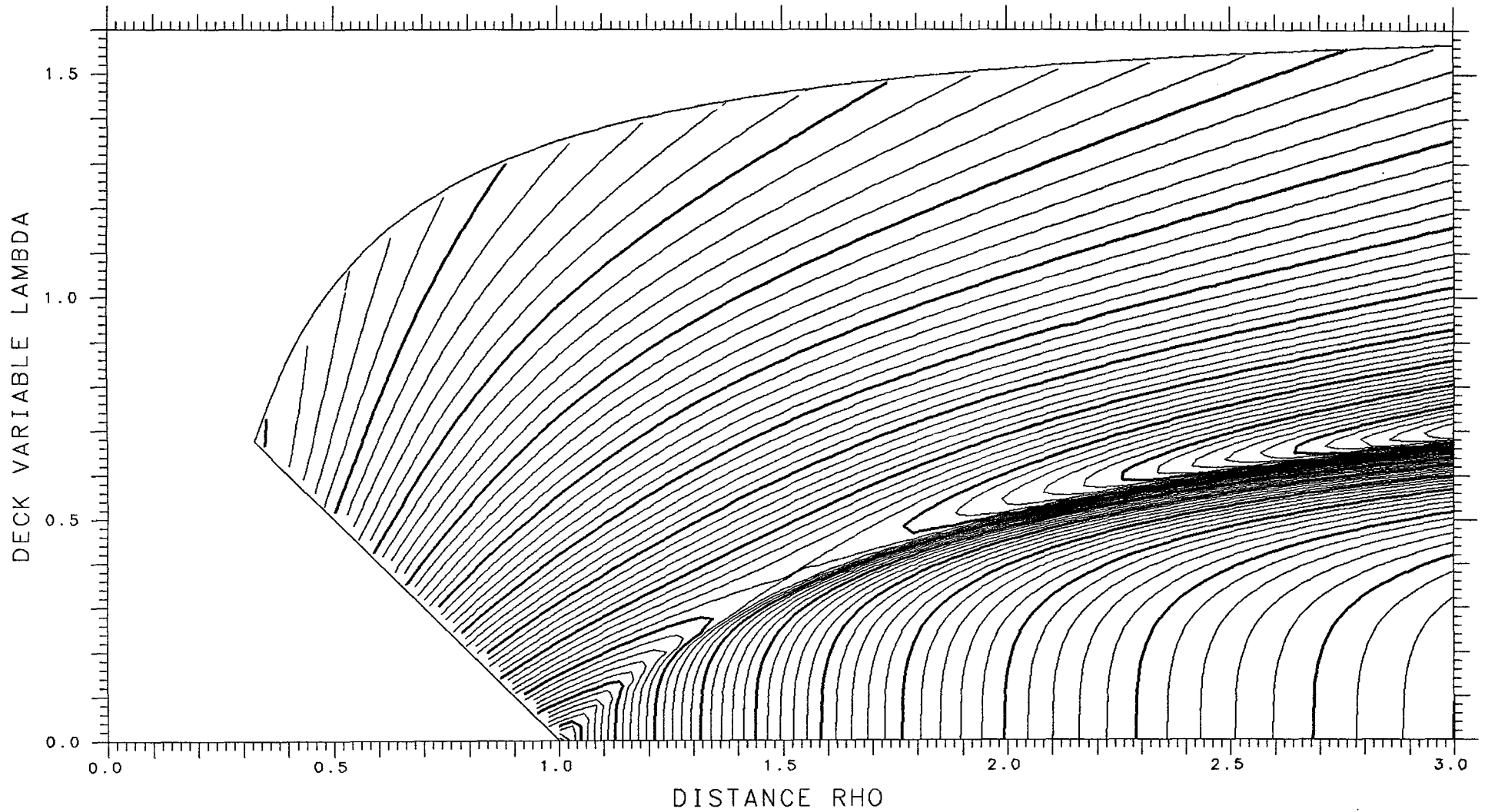

X= .825 ASYMMETRY DELTA= .150 FRACTIONAL= .7124

SPHERES -.27230 TANGENT .09049 LENGTH 12.046 ENERGY 655.09 SPACING .002 SADDLE .00616

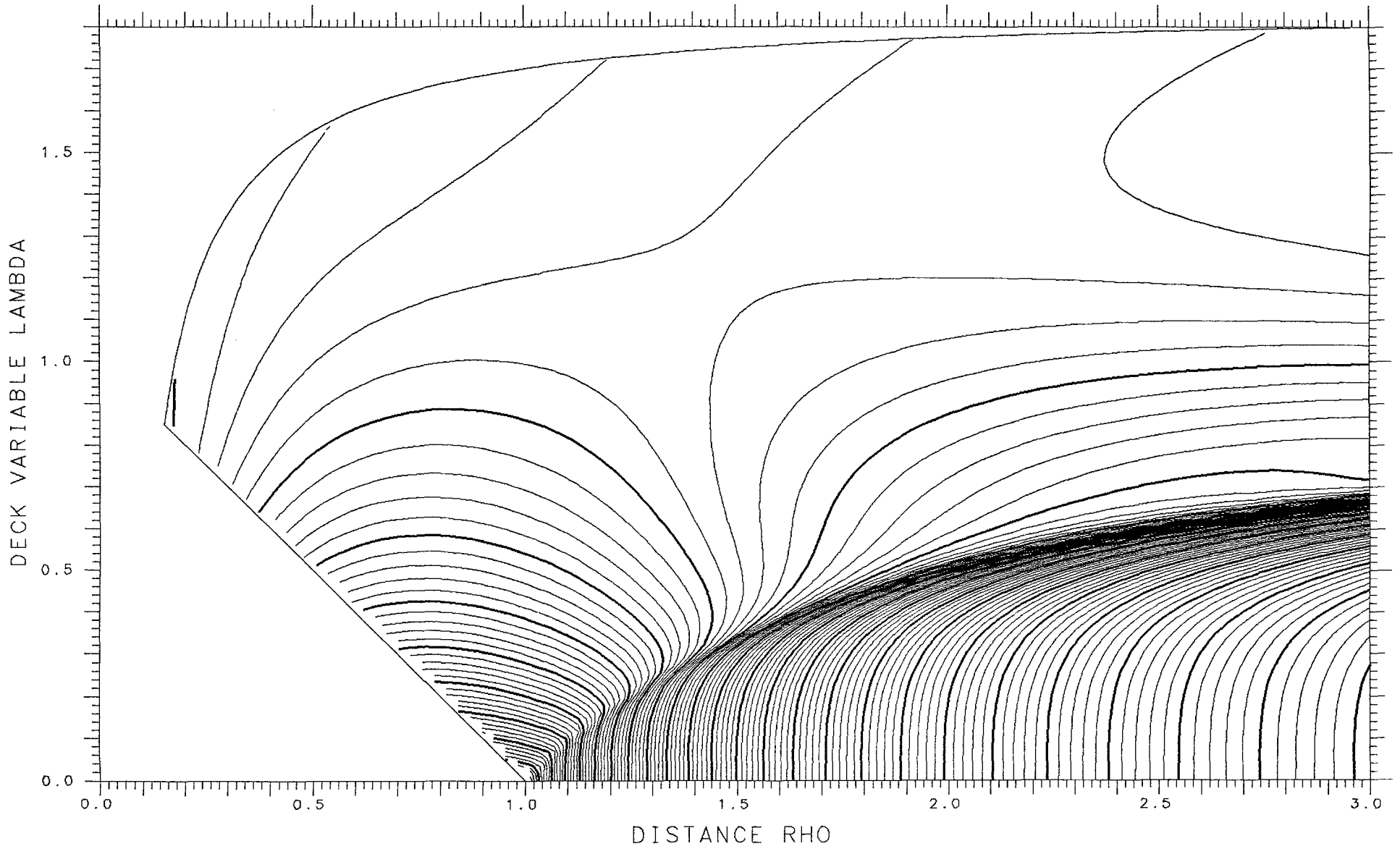

X= .650 ASYMMETRY DELTA= .350 FRACTIONAL= .8996

SPHERES -.03407 TANGENT .10278 LENGTH 10.077 ENERGY 553.46 SPACING .002 SADDLE .07845

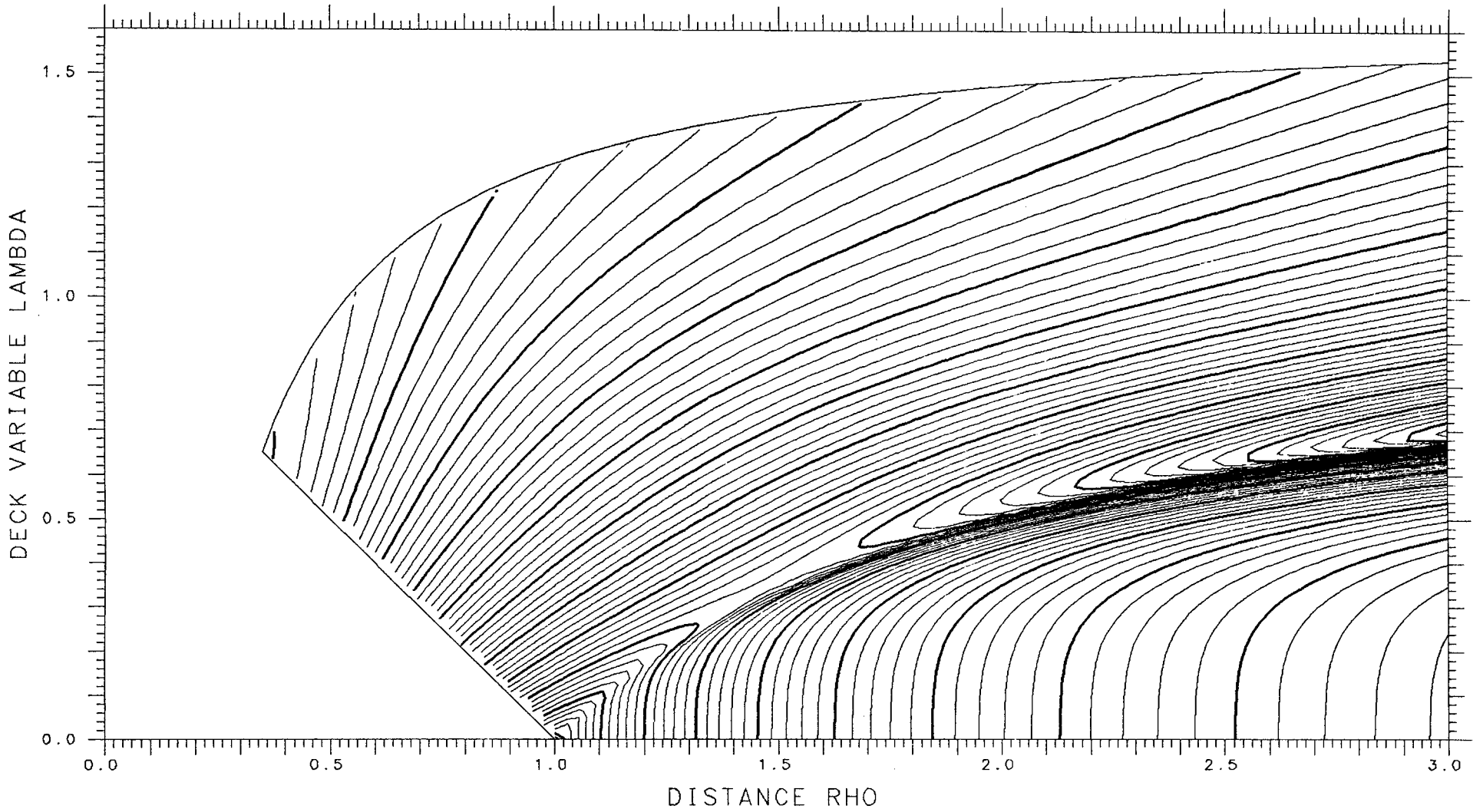

X= .825 ASYMMETRY DELTA= .125 FRACTIONAL= .6800

SPHERES -.29420 TANGENT .08854 LENGTH 12.125 ENERGY 655.09 SPACING .002 SADDLE .00571

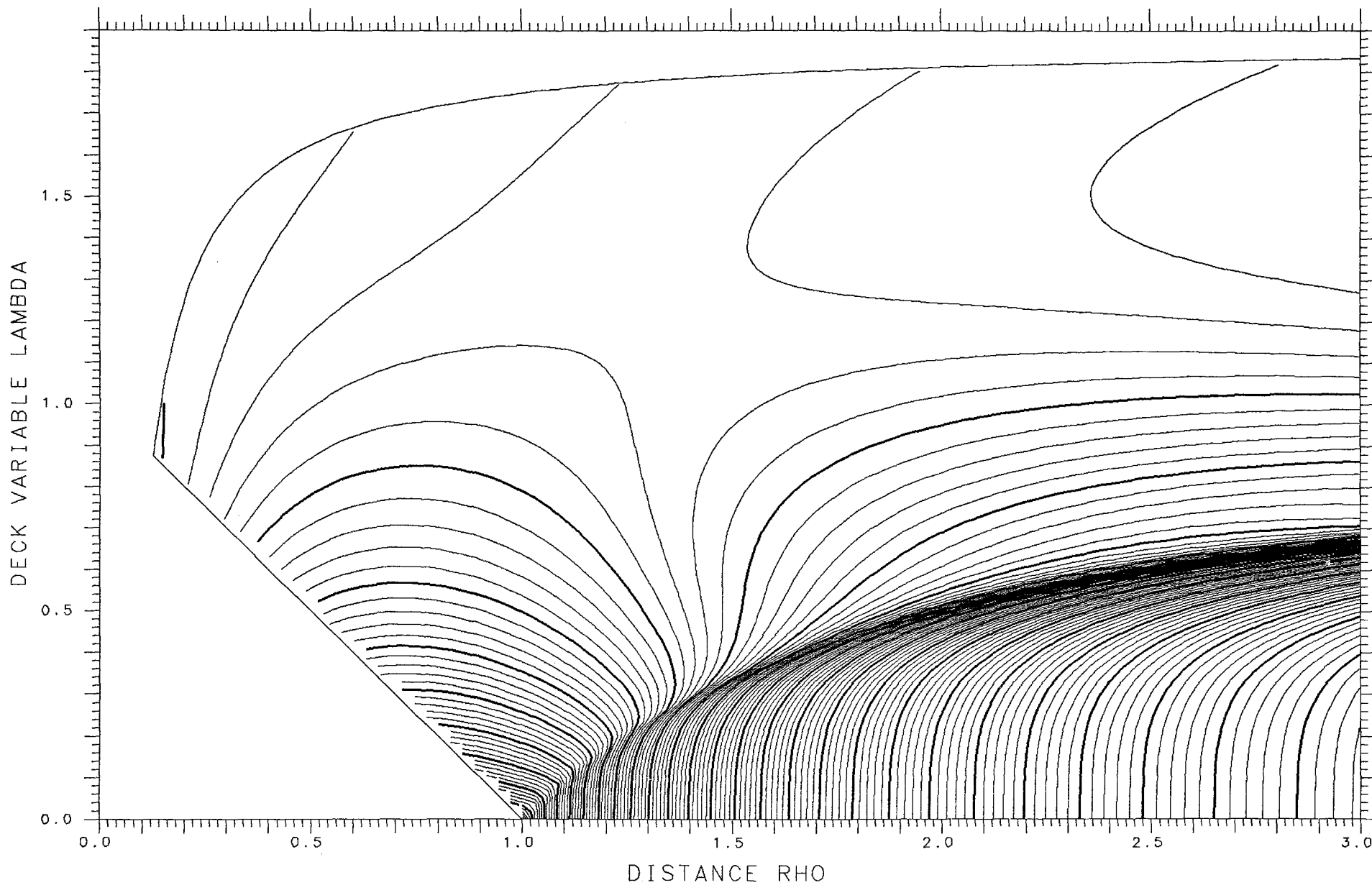

X= .650 ASYMMETRY DELTA= .375 FRACTIONAL= .9141

SPHERES -.02239 TANGENT .09806 LENGTH 9.947 ENERGY 553.46 SPACING .002 SADDLE .07792

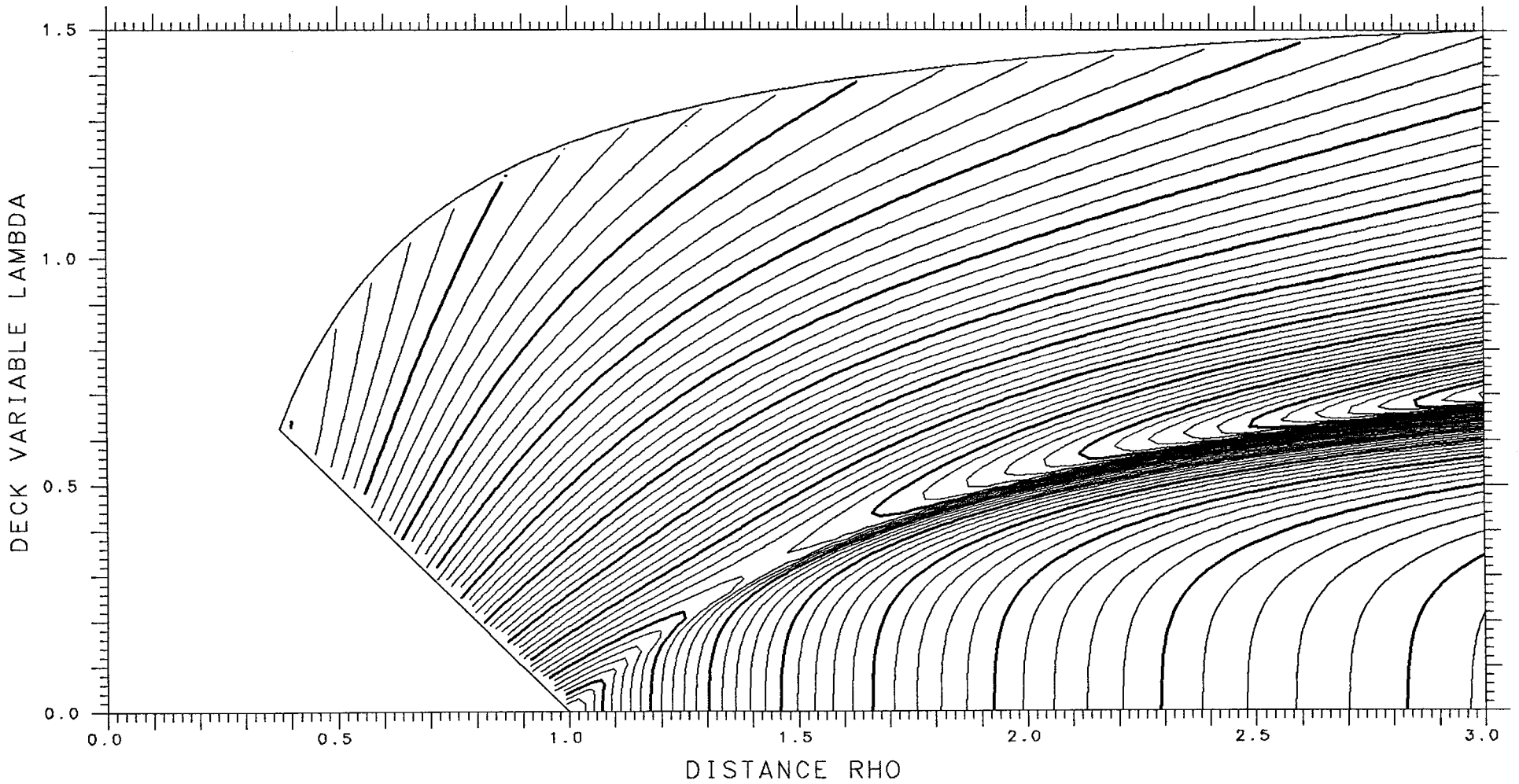

X= .825

ASYMMETRY DELTA= .100

FRACTIONAL= .6461

SPHERES -.31340

TANGENT .08663

LENGTH 12.191

ENERGY 655.09

SPACING .002

SADDLE .00531

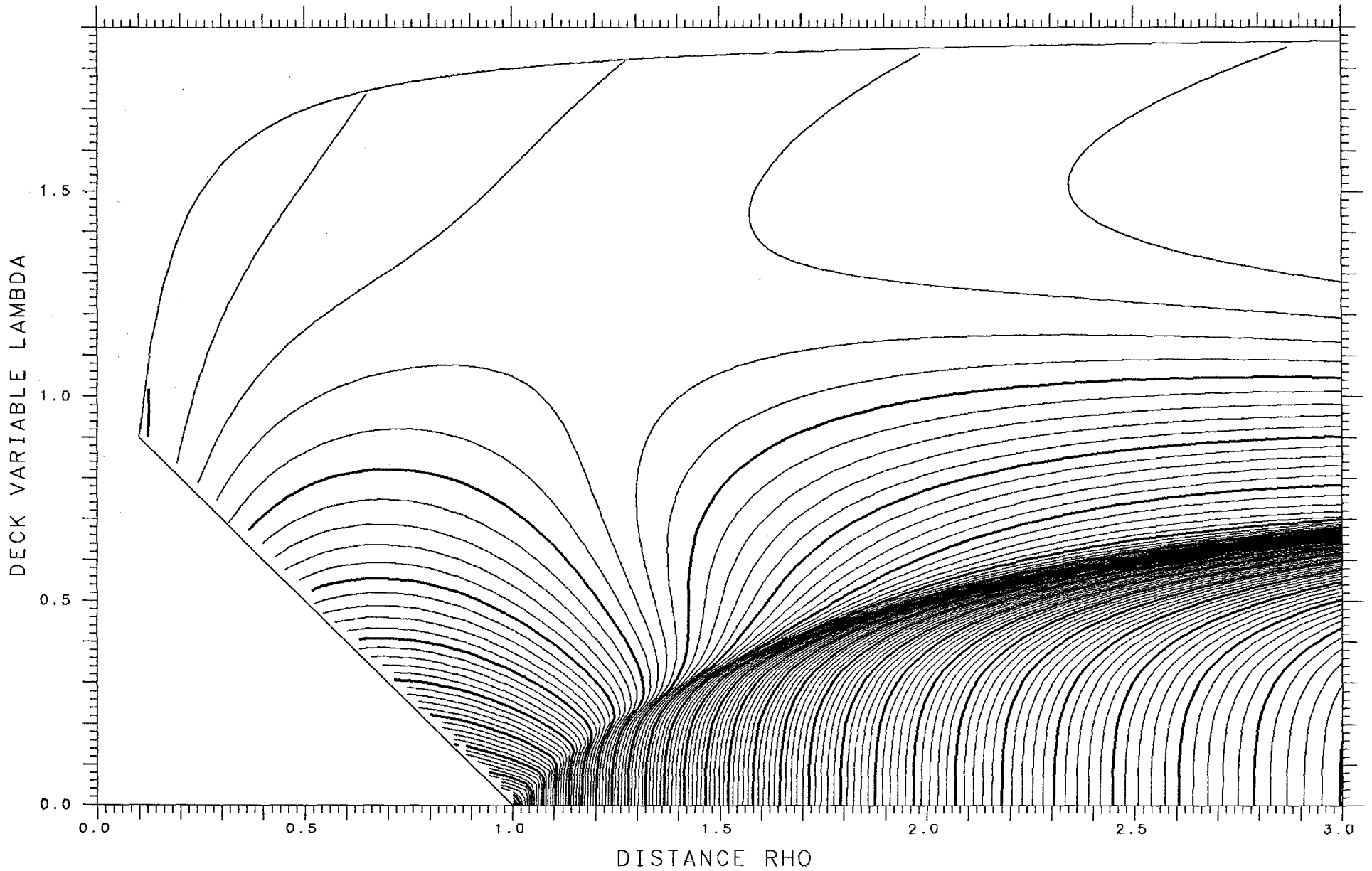

X= .650 ASYMMETRY DELTA= .400 FRACTIONAL= .9270

SPHERES -.01230 TANGENT .09292 LENGTH 9.815 ENERGY 553.46 SPACING .002 SADDLE .07648

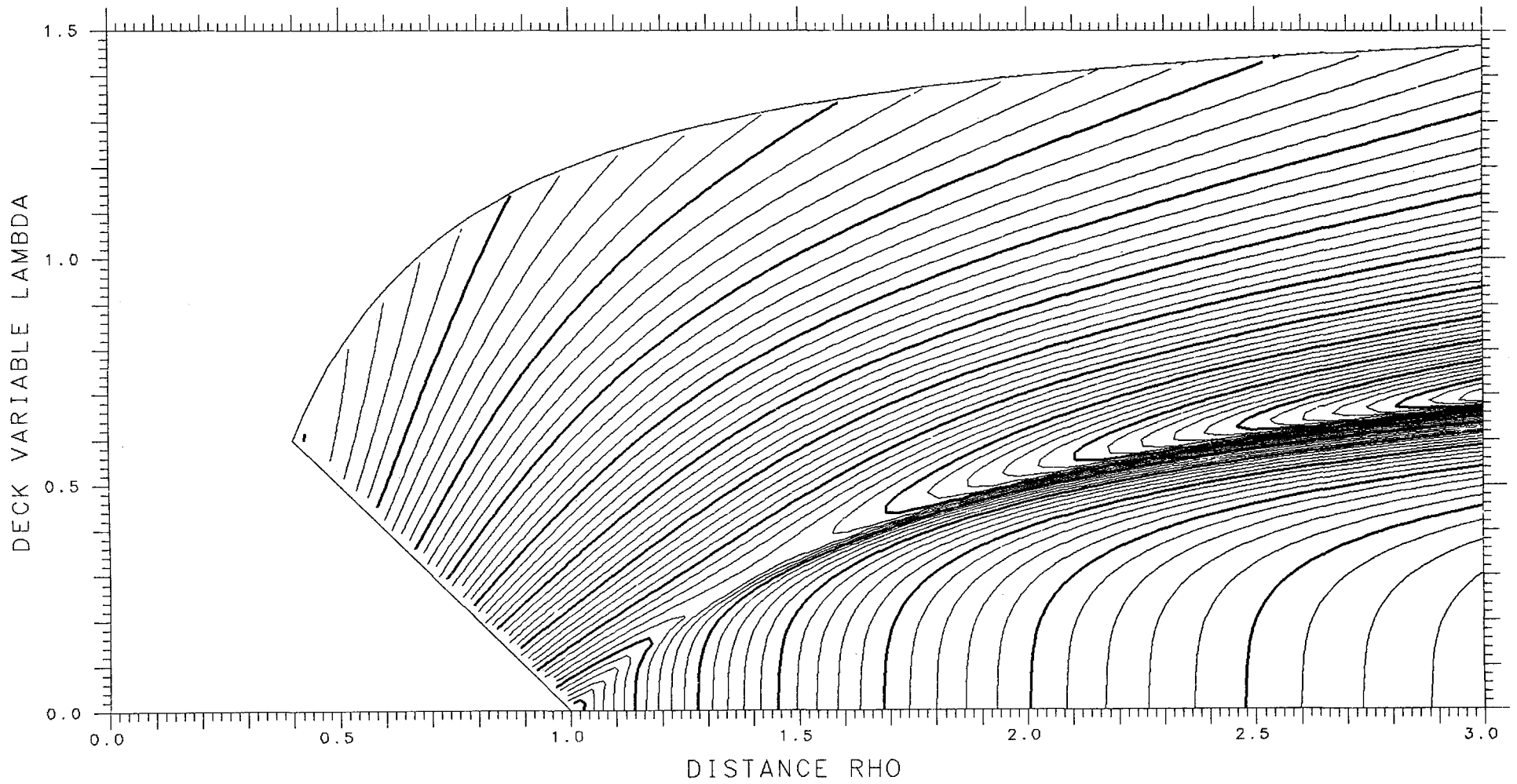

X= .825 ASYMMETRY DELTA= .075 FRACTIONAL= .6108

SPHERES -.32918 TANGENT .08493 LENGTH 12.243 ENERGY 655.09 SPACING .002 SADDLE .00497

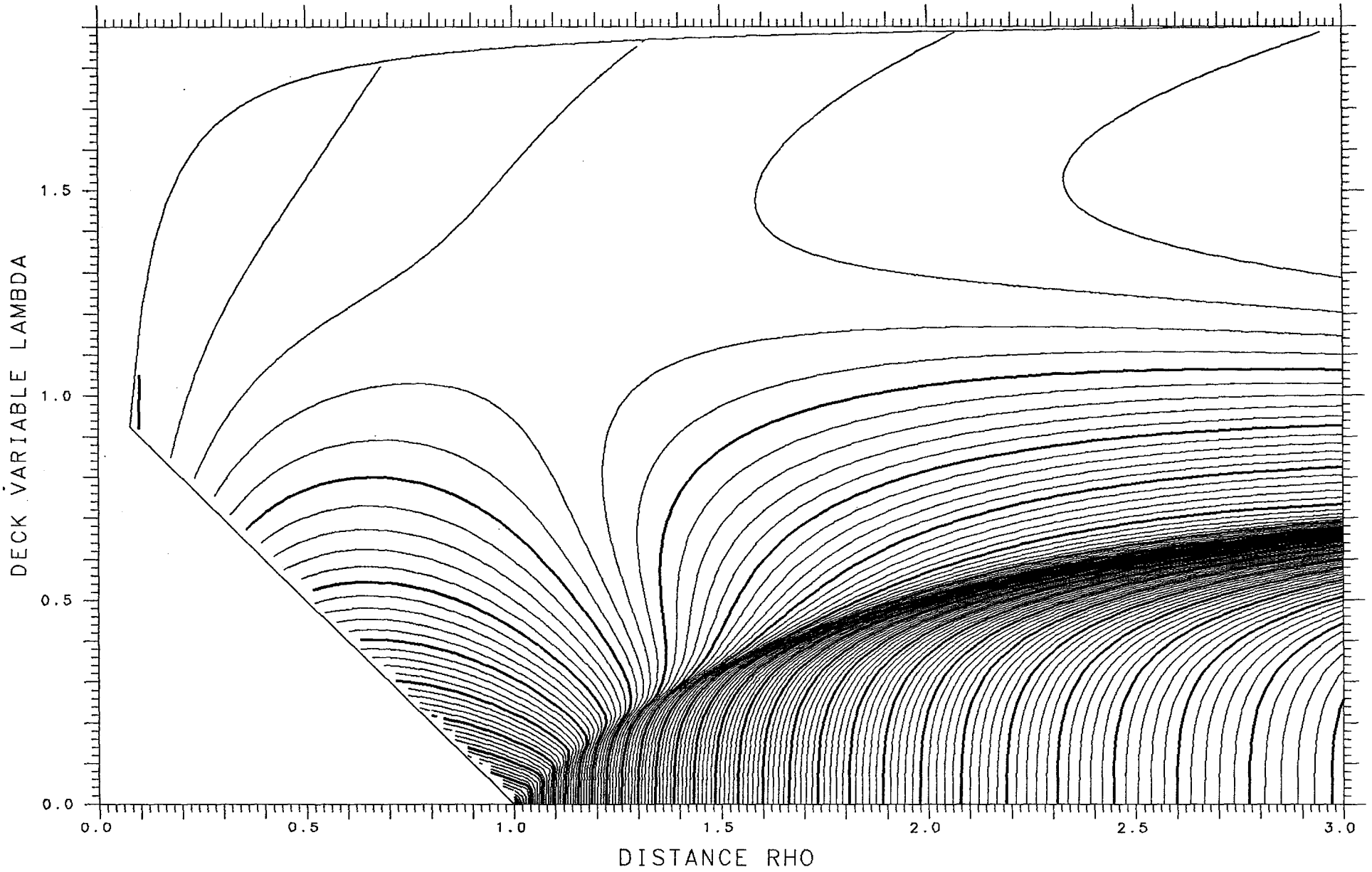

X= .650

ASYMMETRY DELTA= .425

FRACTIONAL= .9384

SPHERES -.00378

TANGENT .08744

LENGTH 9.682

ENERGY 553.46

SPACING .002

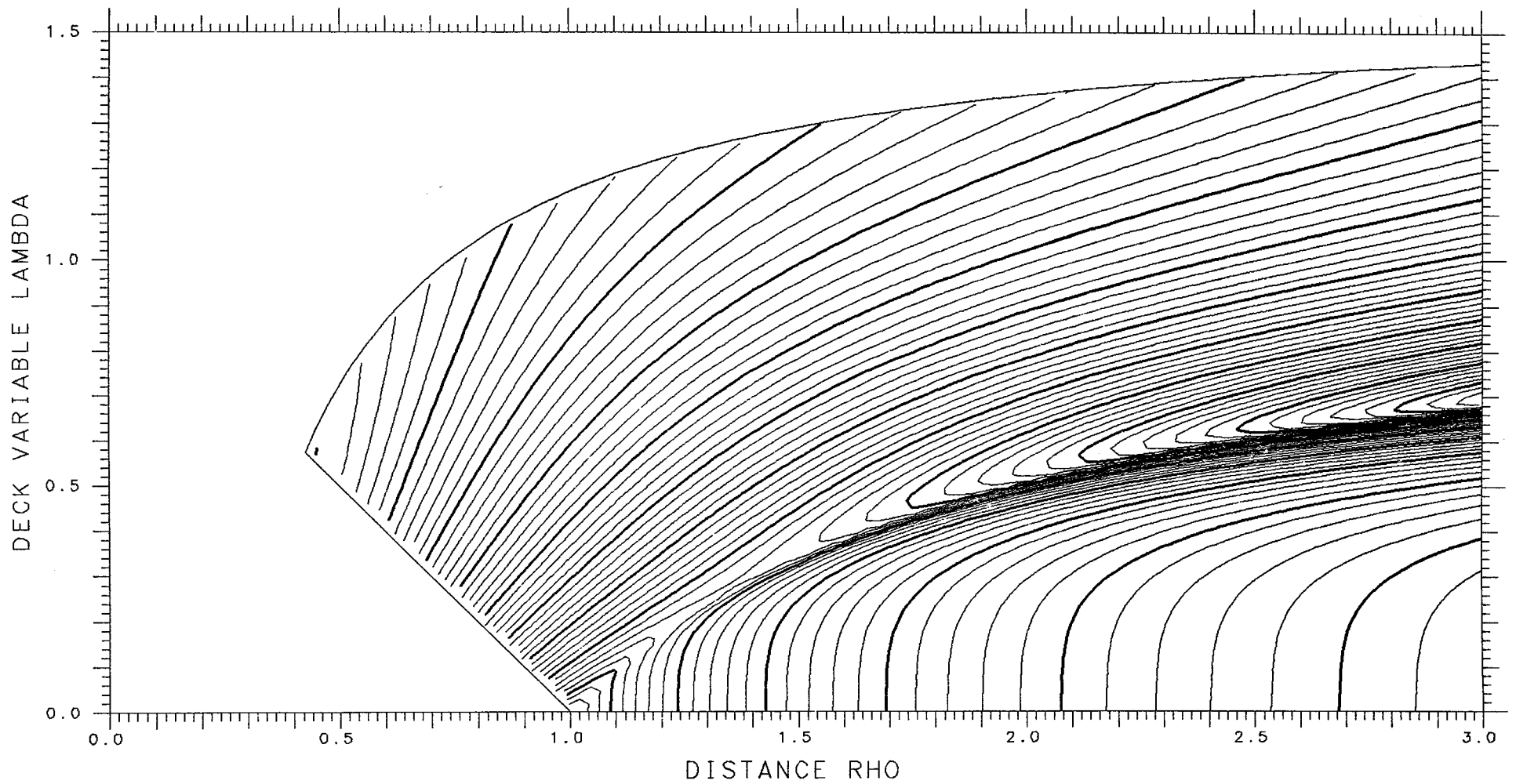

X= .825 ASYMMETRY DELTA= .050 FRACTIONAL= .5745

SPHERES -.34094 TANGENT .08360 LENGTH 12.281 ENERGY 655.09 SPACING .002 SADDLE .00471

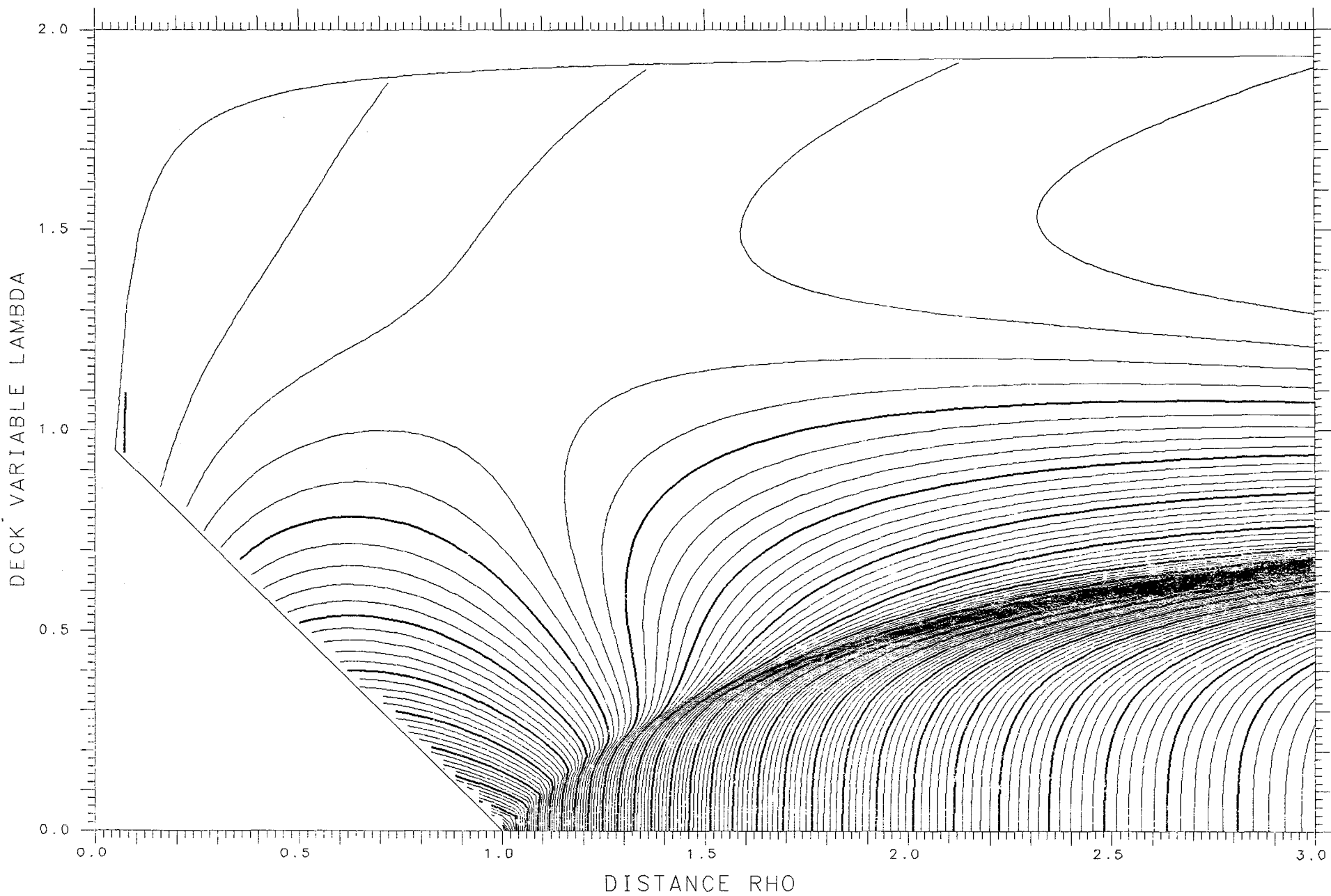

X= .650 ASYMMETRY DELTA= .450 FRACTIONAL= .9483

SPHERES .00323 TANGENT .08169 LENGTH 9.549 ENERGY 553.46 SPACING .002

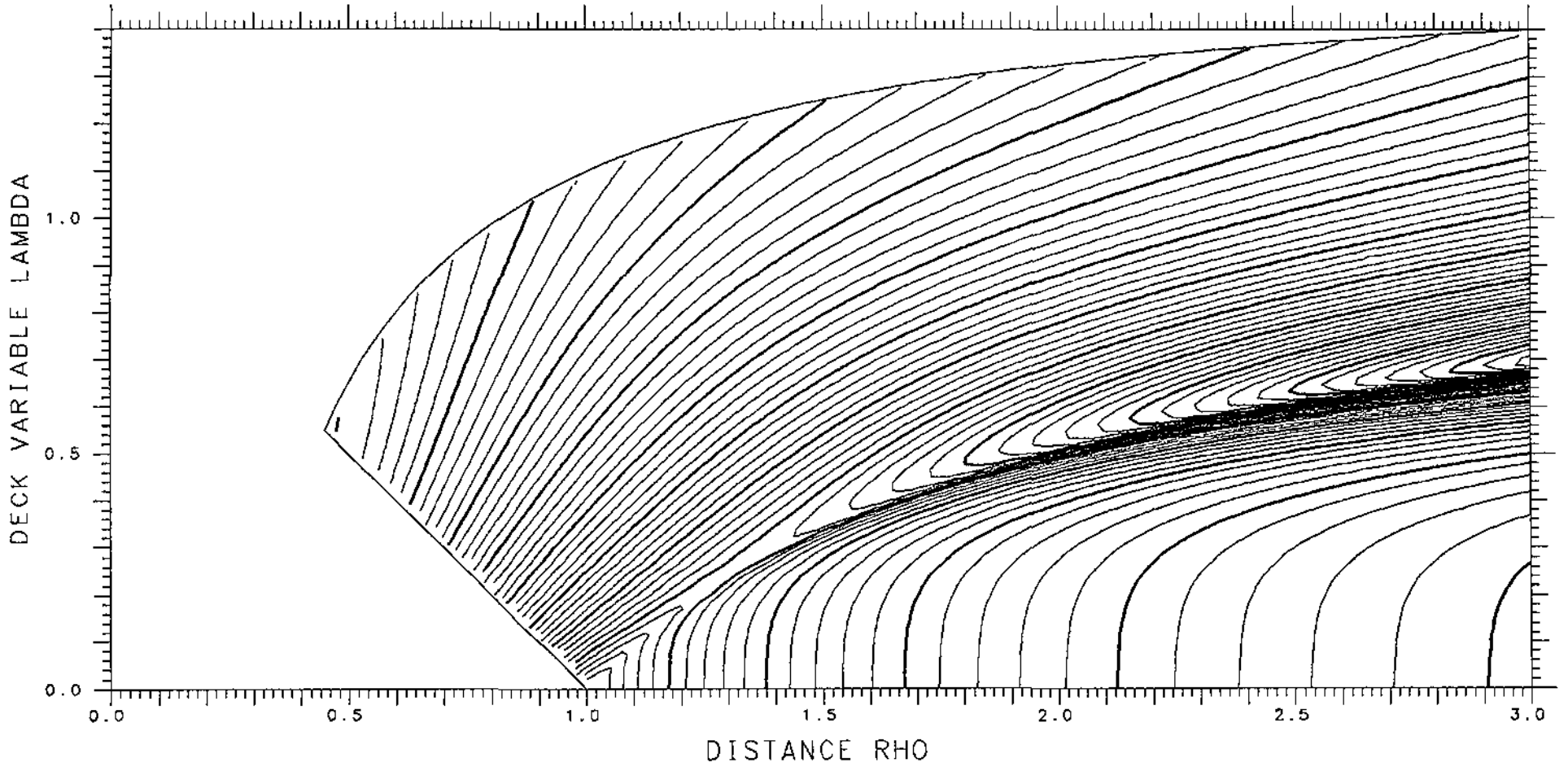

X= .825 ASYMMETRY DELTA= .025 FRACTIONAL= .5374

SPHERES -.34819 TANGENT .08275 LENGTH 12.304 ENERGY 655.09 SPACING .002 SADDLE .00455

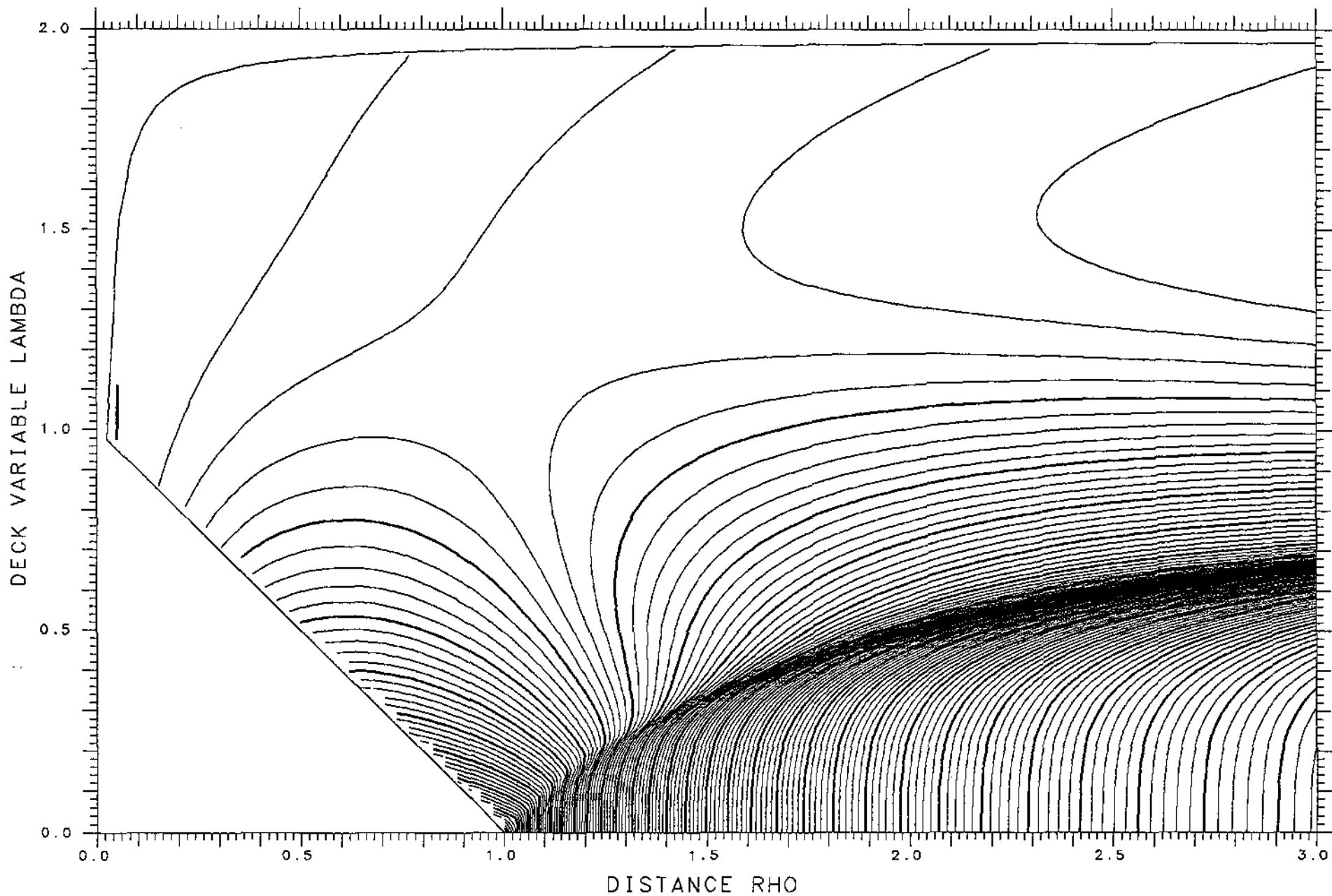

X= .650

ASYMMETRY DELTA= .475

FRACTIONAL= .9569

SPHERES .00881

TANGENT .07576

LENGTH 9.415

ENERGY 553.46

SPACING .002

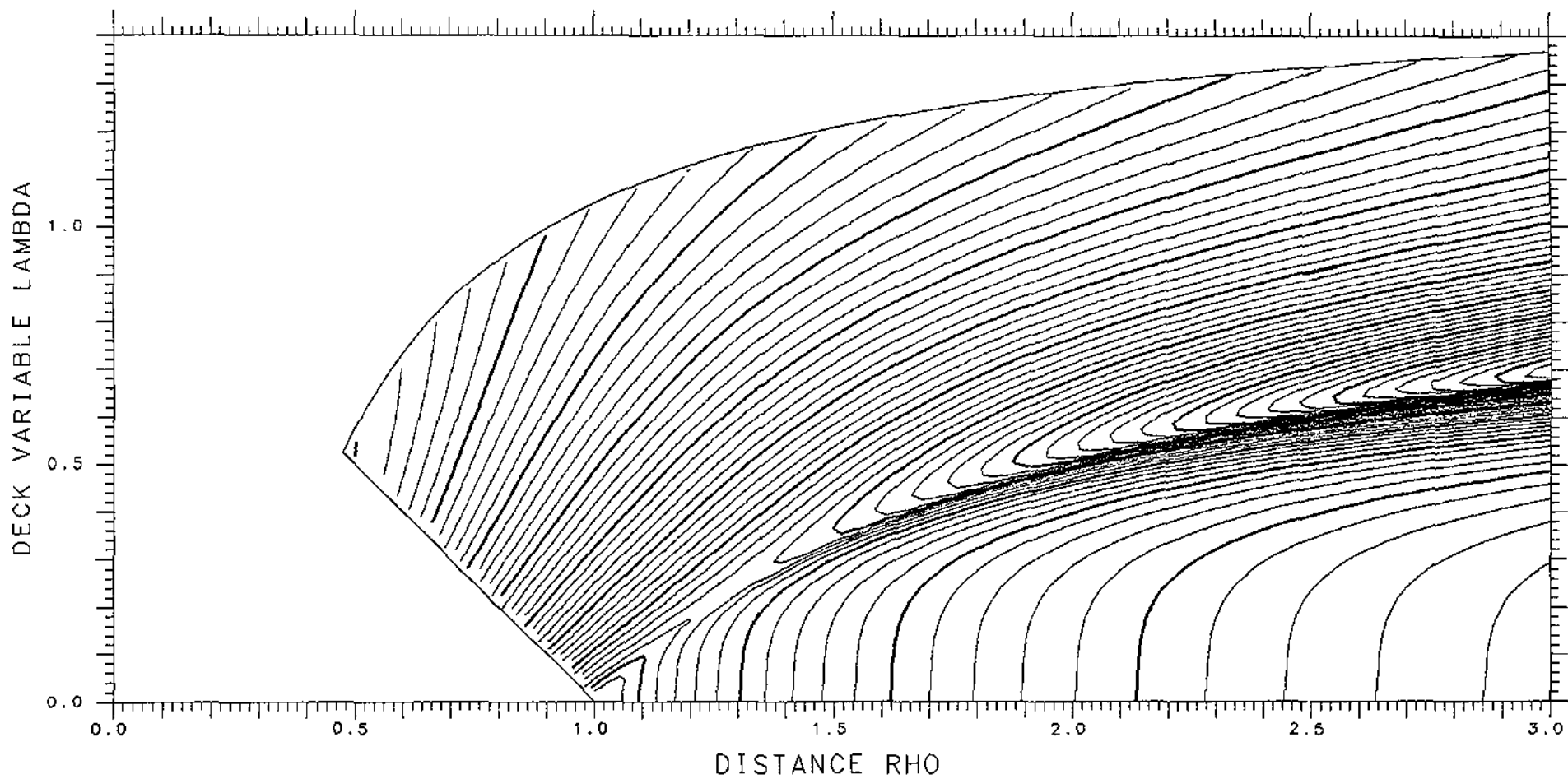

X = .825

ASYMMETRY DELTA=0.

FRACTIONAL = .5000

SPHERES = .35064

TANGENT .08245

LENGTH 12.311

ENERGY 655.09

SPACING .002

SADDLE .00449

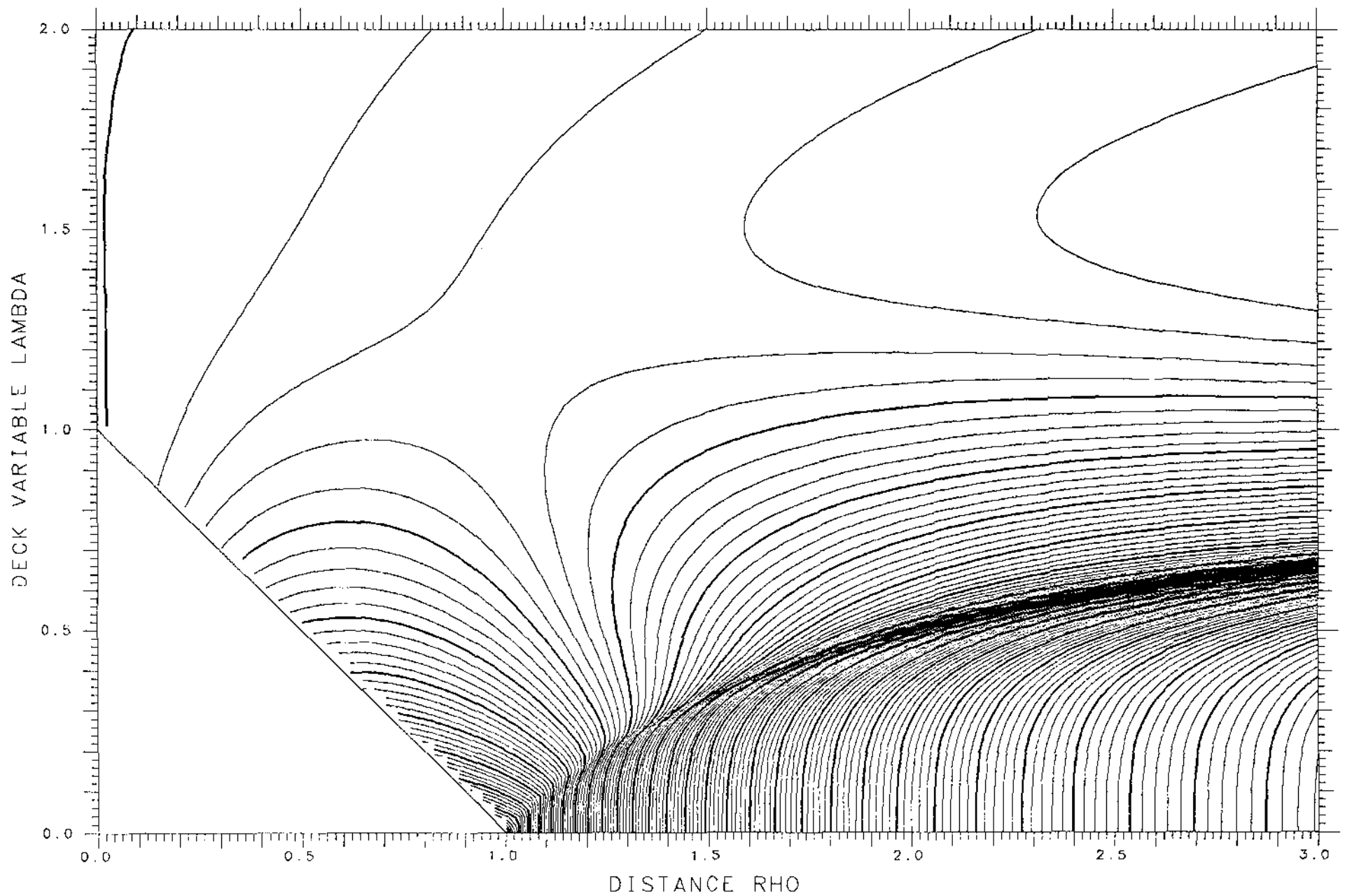

X= .650 ASYMMETRY DELTA= .500 FRACTIONAL= .9643

SPHERES .01308 TANGENT .06972 LENGTH 9.282 ENERGY 553.46 SPACING .002

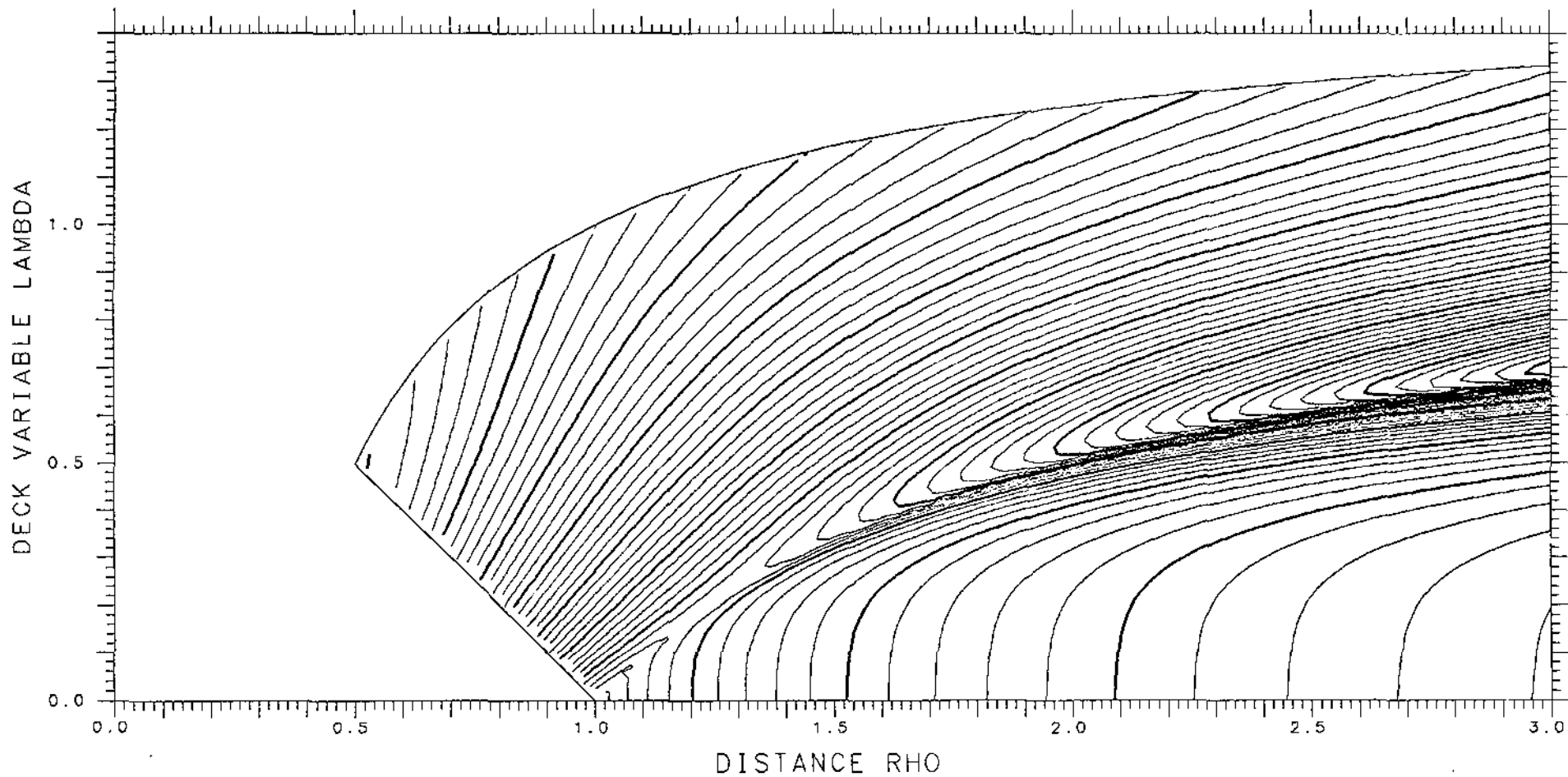

X= .800 ASYMMETRY DELTA= .600 FRACTIONAL= .9846

SPHERES .01228 TANGENT .04477 LENGTH 9.526 ENERGY 641.16 SPACING .002

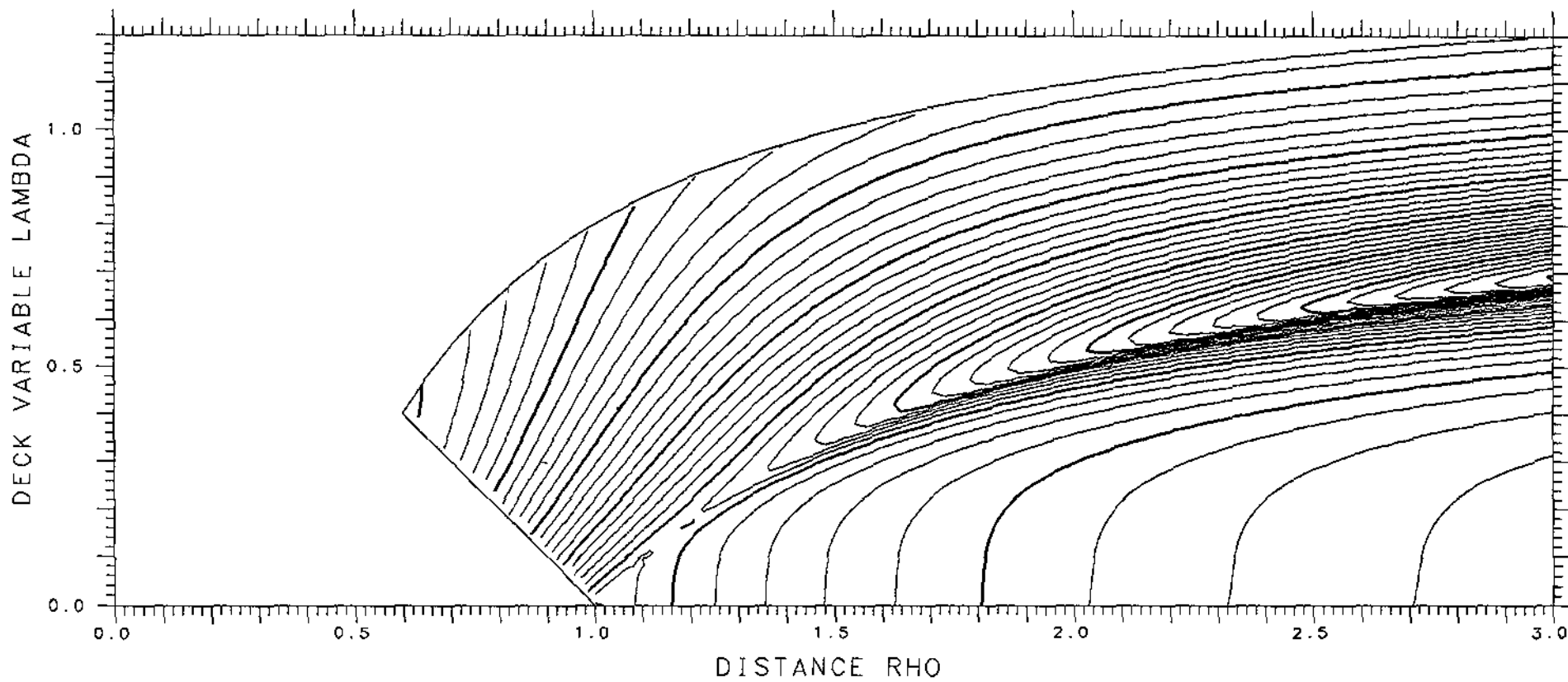

X= .650 ASYMMETRY DELTA= .525 FRACTIONAL= .9707

SPHERES .01616 TANGENT .06366 LENGTH 9.150 ENERGY 553.46 SPACING .002

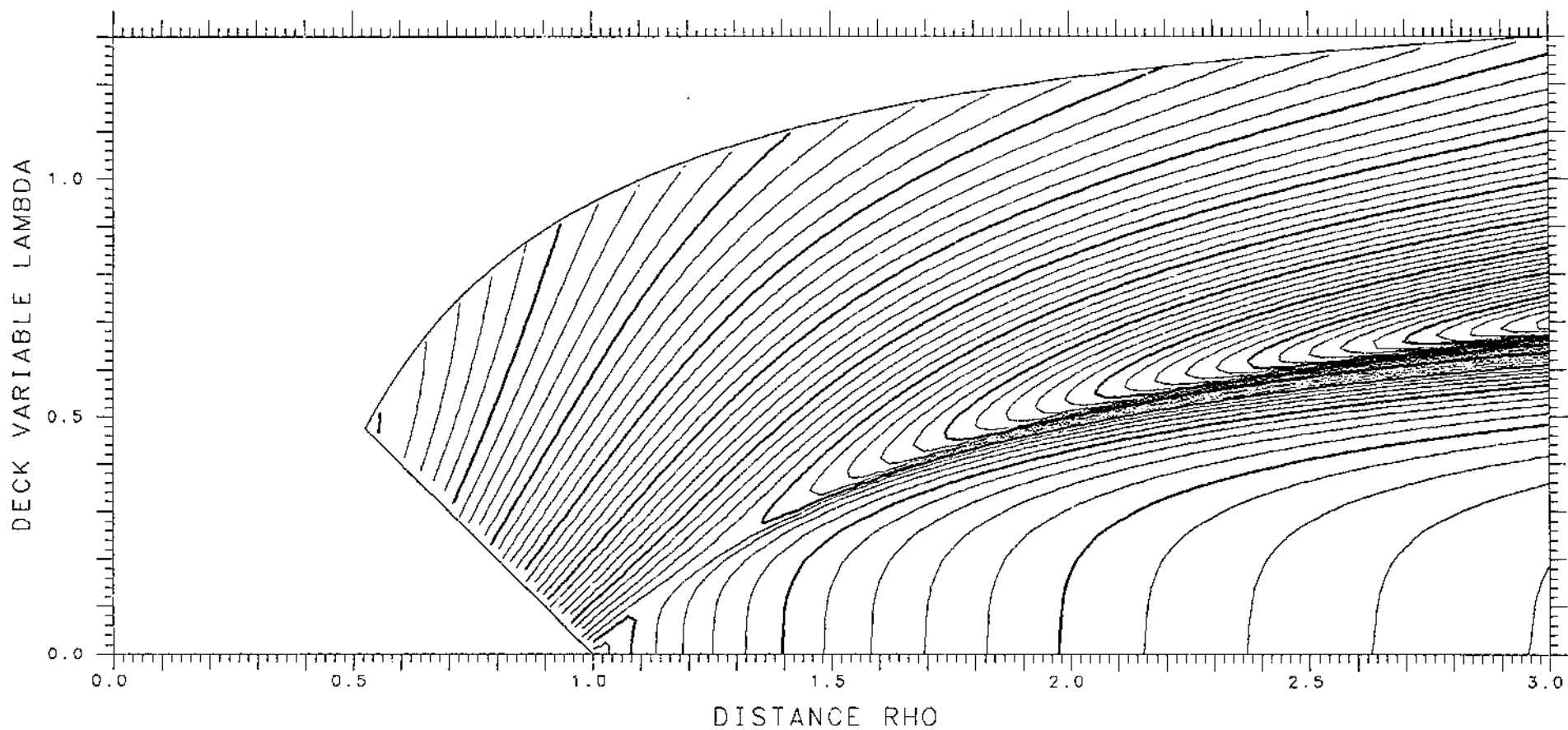

X= .800 ASYMMETRY DELTA= .575 FRACTIONAL= .9807

SPHERES .01015 TANGENT .05009 LENGTH 9.665 ENERGY 641.16 SPACING .002

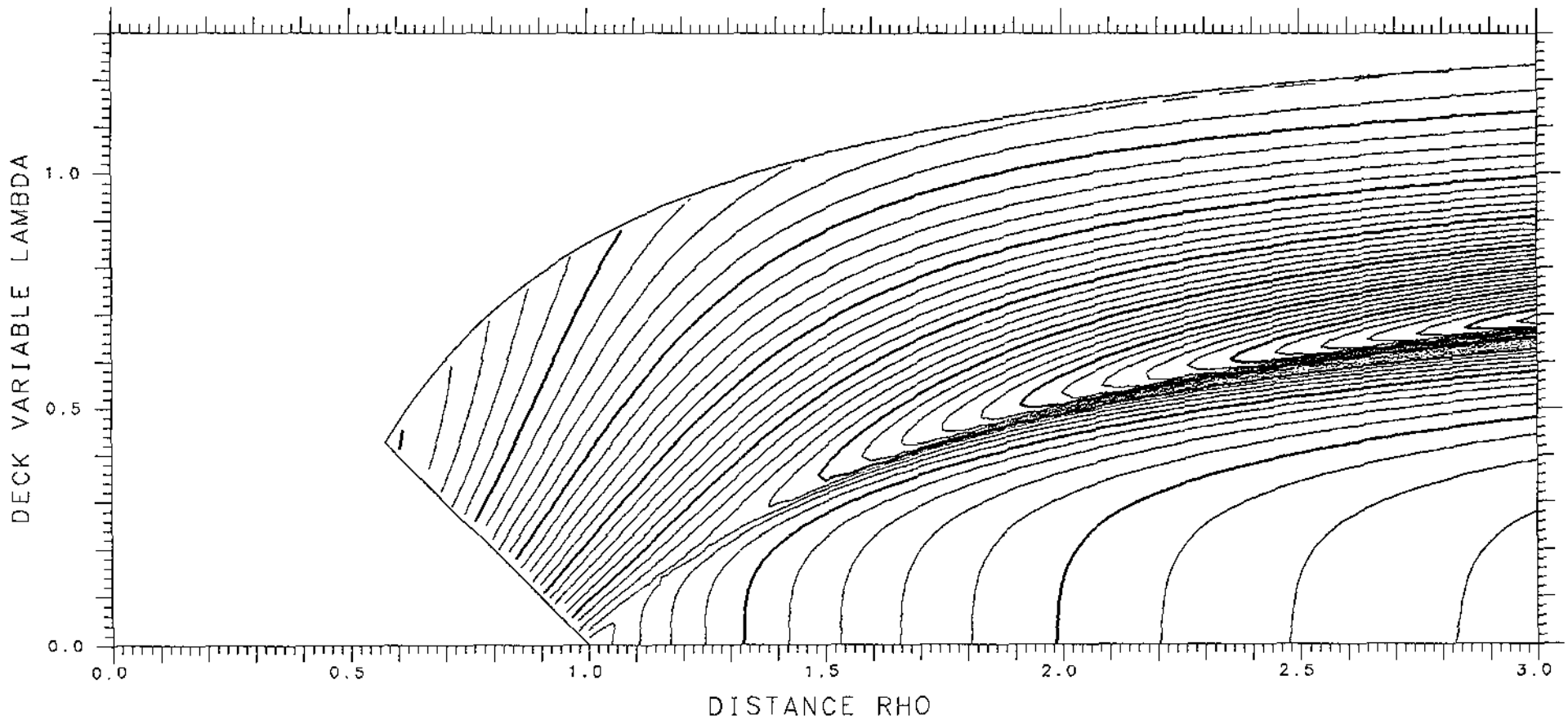

X= .650 ASYMMETRY DELTA= .550 FRACTIONAL= .9761

SPHERES .01819 TANGENT .05765 LENGTH 9.019 ENERGY 553.46 SPACING .002

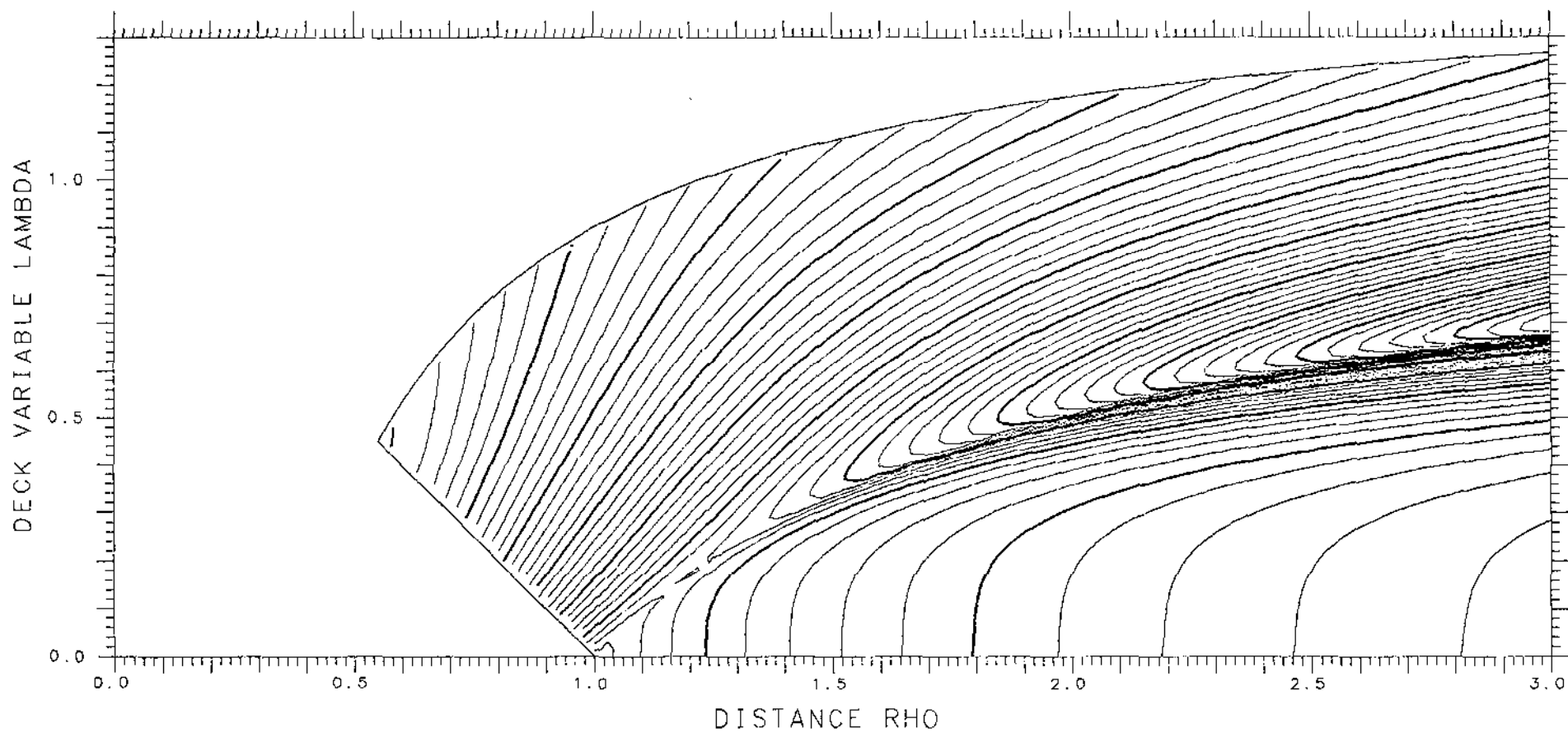

X = .800 ASYMMETRY DELTA = .550 FRACTIONAL = .9761

SPHERES .00693 TANGENT .05551 LENGTH 9.805 ENERGY 641.16 SPACING .002

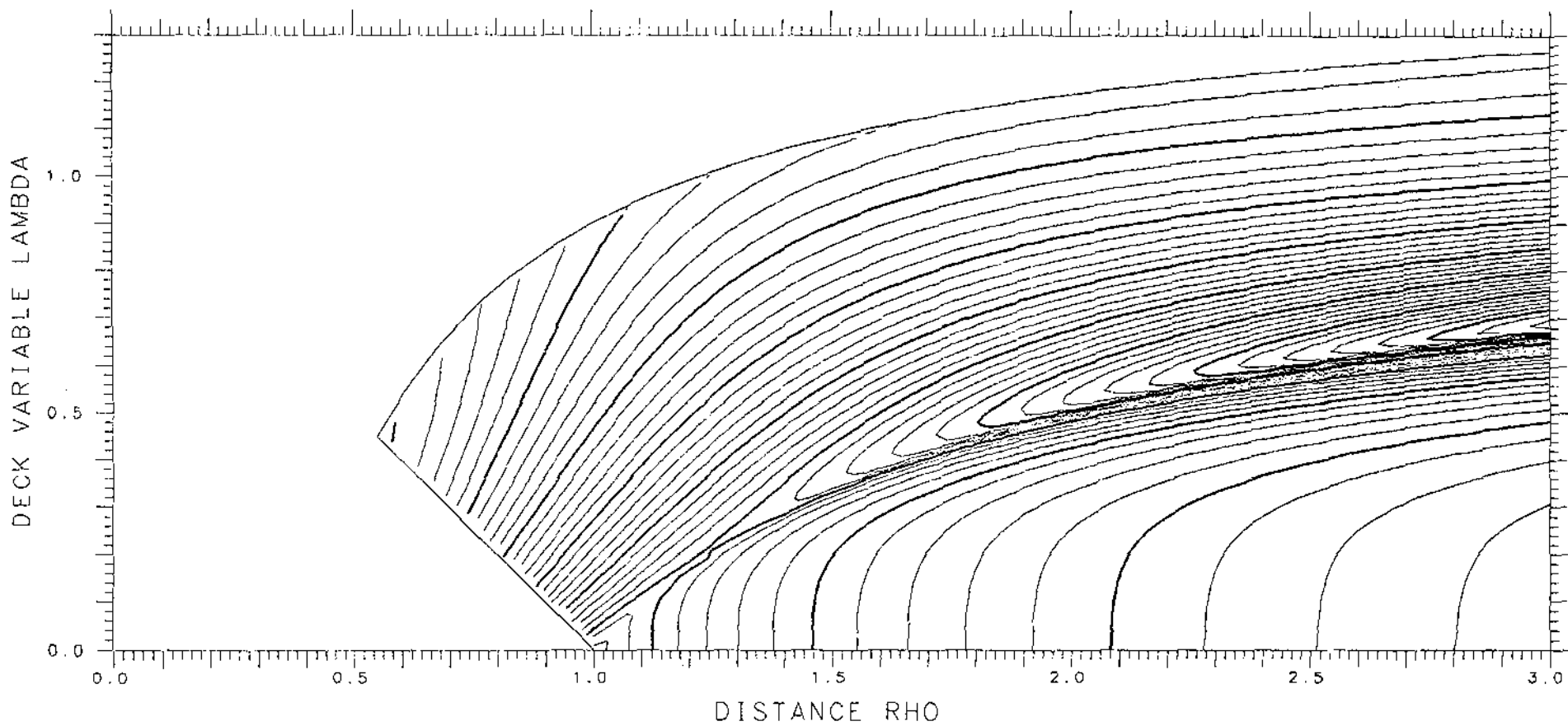

X= .675 ASYMMETRY DELTA=0. FRACTIONAL= .5000

SPHERES -.23963 TANGENT .11472 LENGTH 11.357 ENERGY 568.61 SPACING .002 SADDLE .03206

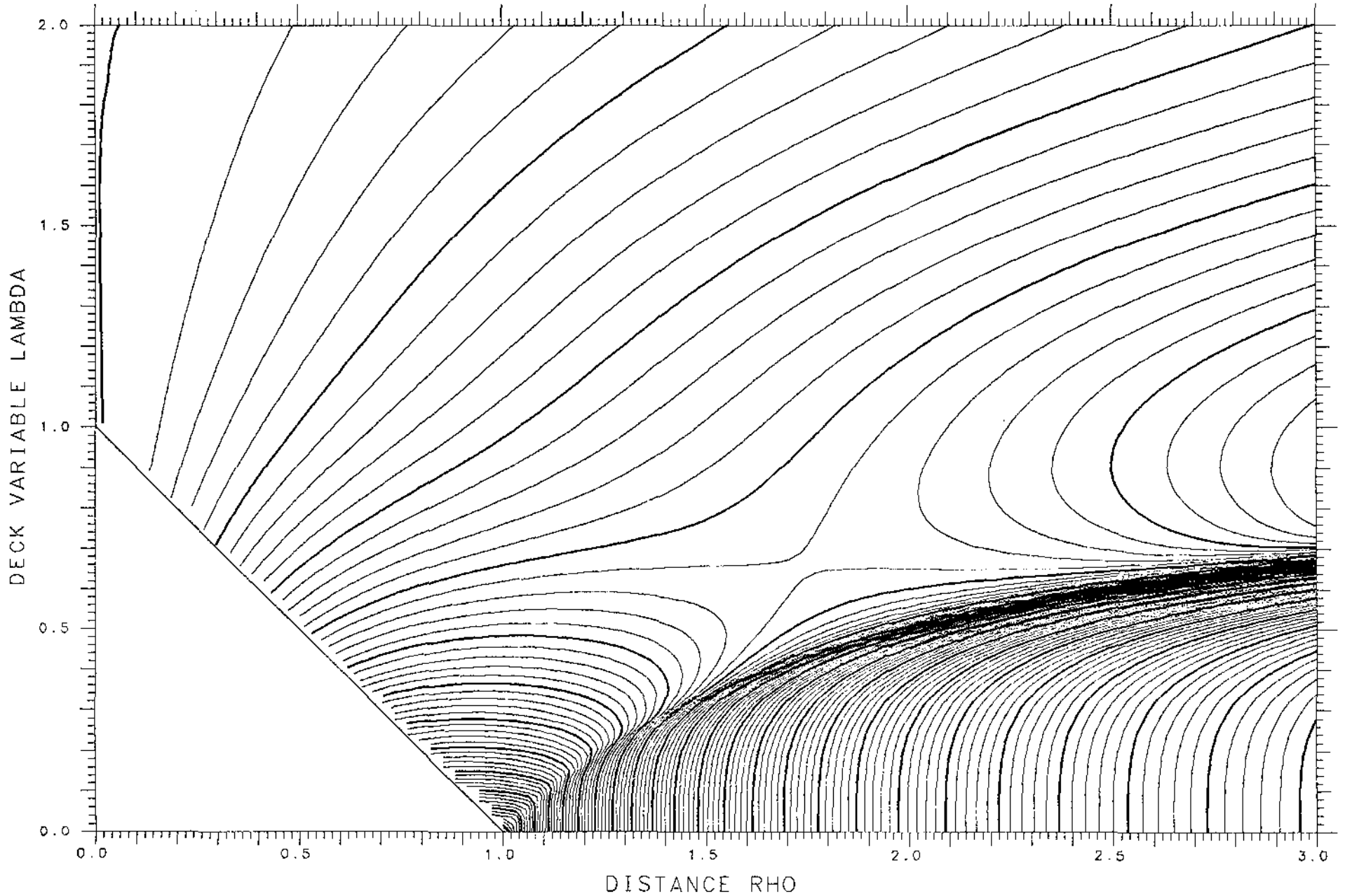

X = .800
SPHERES .00247 TANGENT .06094 LENGTH 9.947 ENERGY 641.16 SPACING .002
ASYMMETRY DELTA = .525 FRACTIONAL = .9707

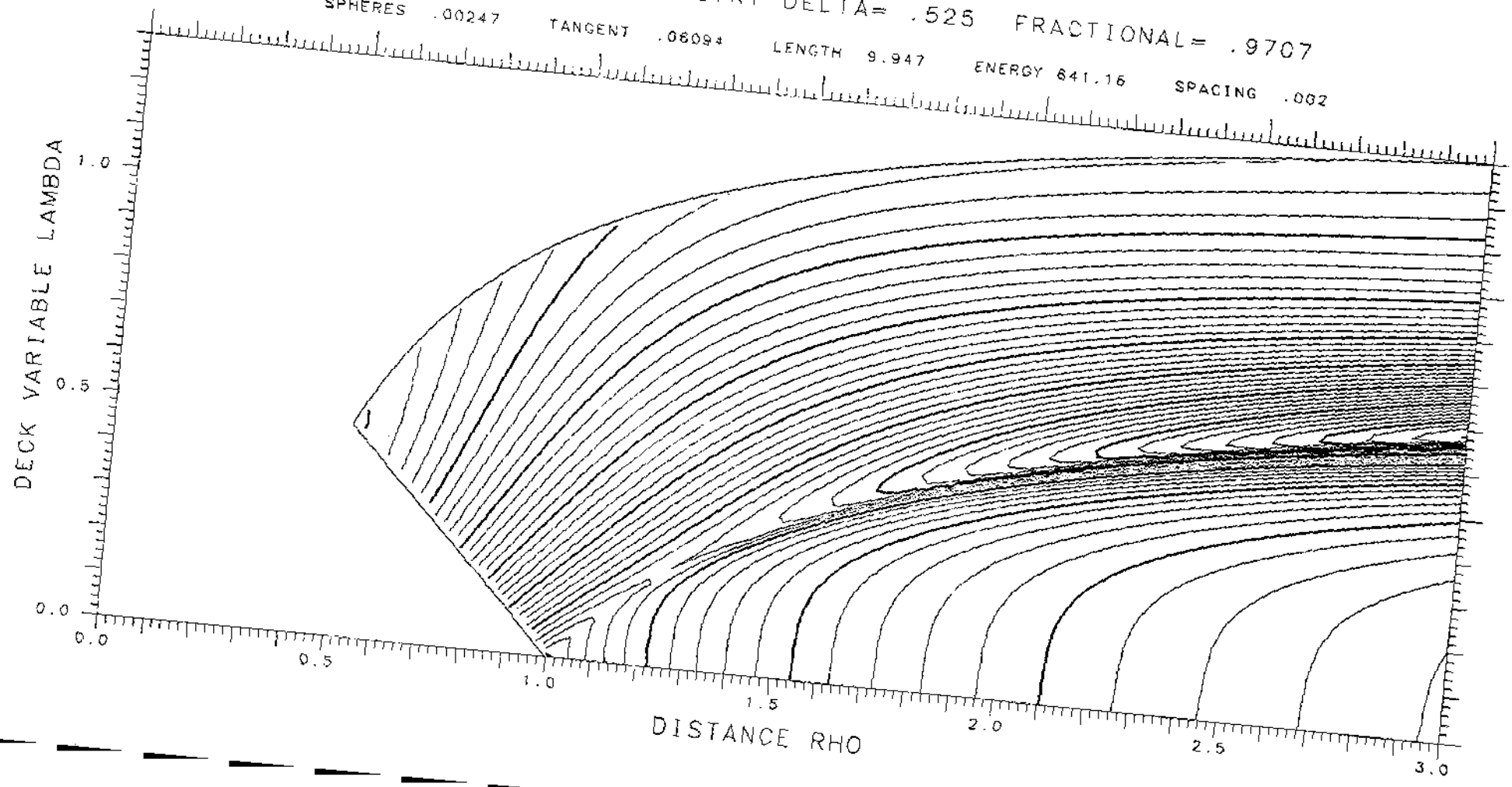

X= .675 ASYMMETRY DELTA= .025 FRACTIONAL= .5374

SPHERES -.23777 TANGENT .11482 LENGTH 11.350 ENERGY 568.61 SPACING .002 SADDLE .03240

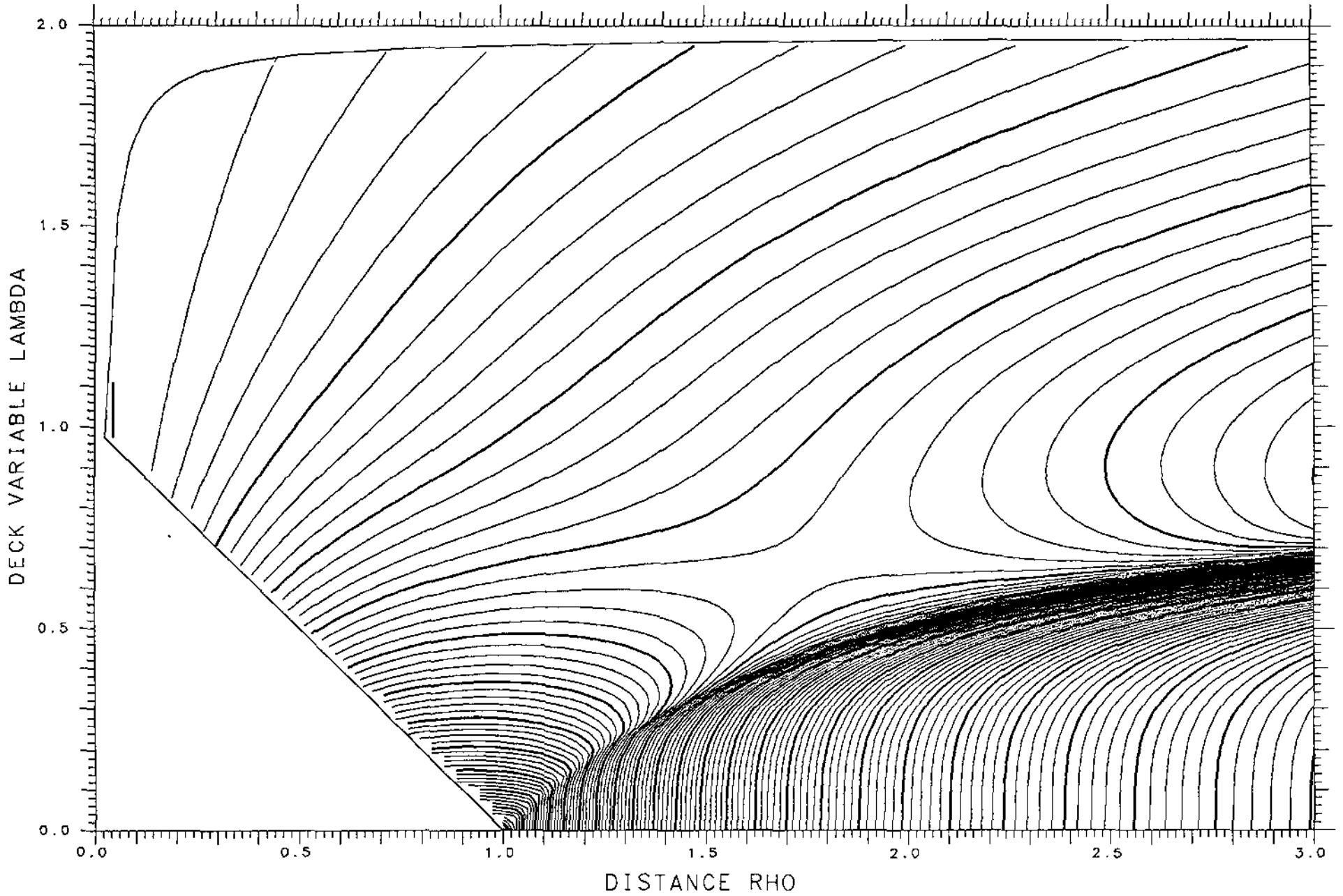

X= .800 ASYMMETRY DELTA= .500 FRACTIONAL= .9643

SPHERES -.00341 TANGENT .06631 LENGTH 10.091 ENERGY 641.16 SPACING .002

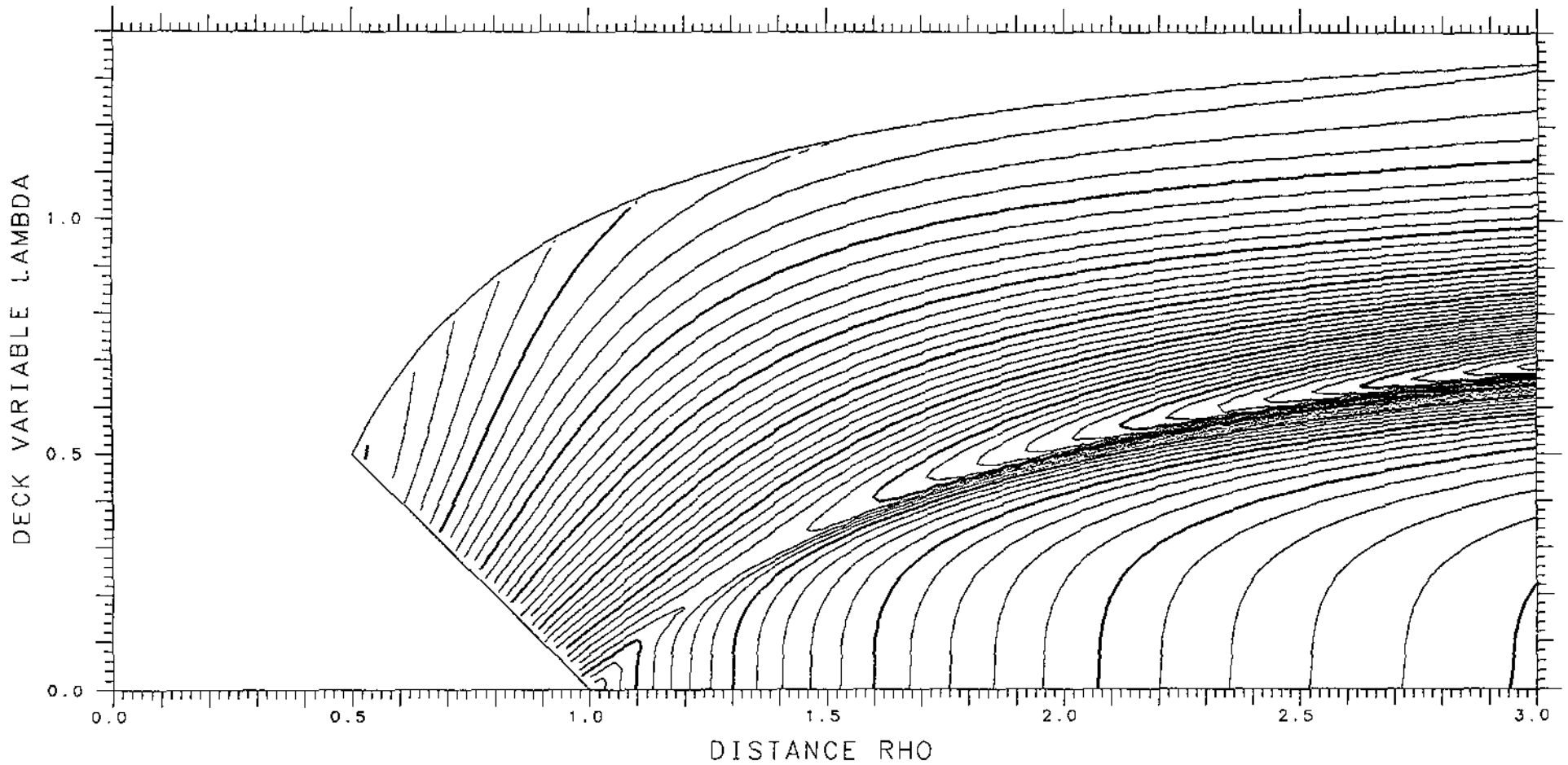

X= .675

ASYMMETRY DELTA= .050

FRACTIONAL= .5745

SPHERES -.23226

TANGENT .11509

LENGTH 11.329

ENERGY 566.61

SPACING .002

SADDLE .03345

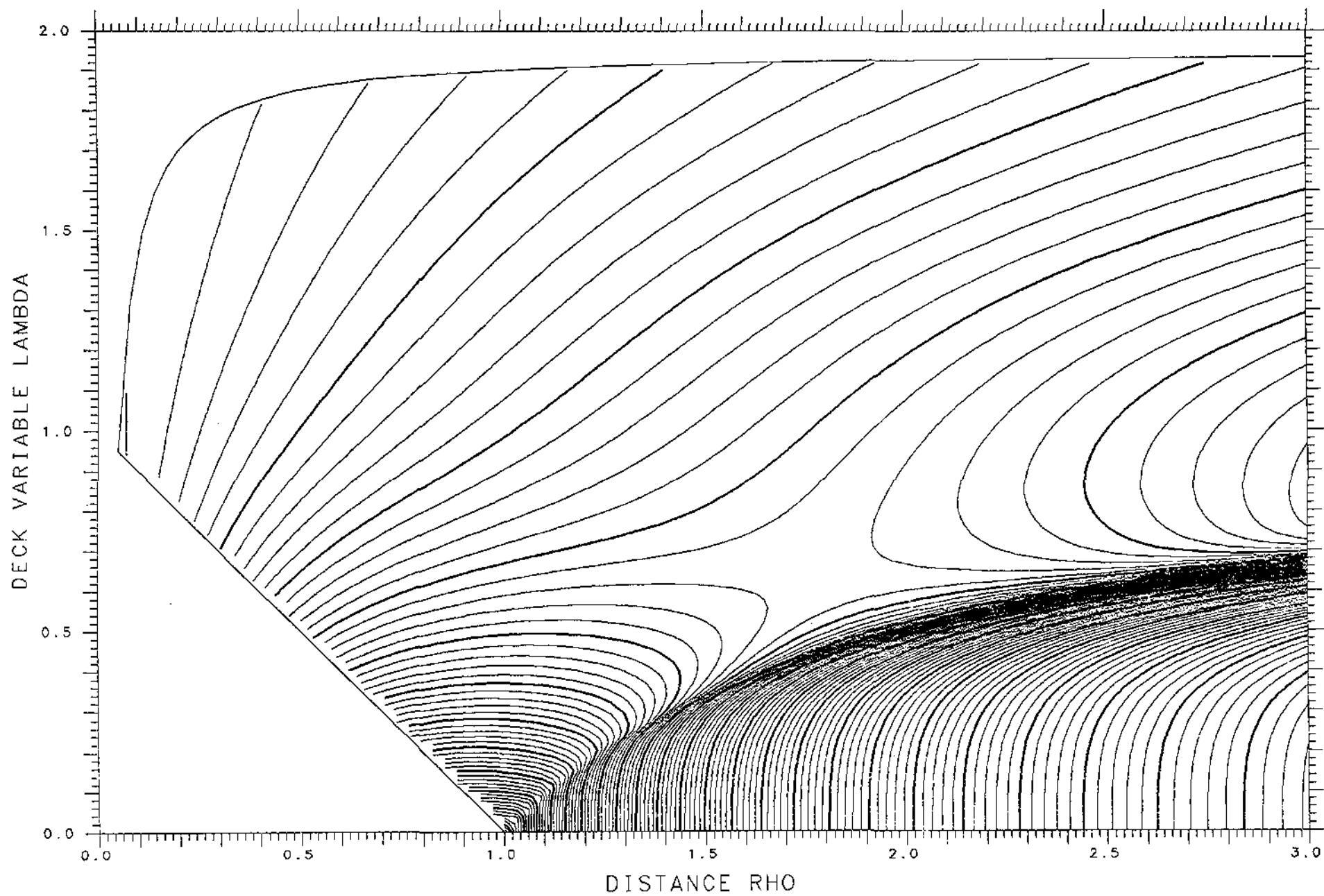

X= .800 ASYMMETRY DELTA= .475 FRACTIONAL= .9569

SPHERES -.01086 TANGENT .07154 LENGTH 10.236 ENERGY 641.16 SPACING .002

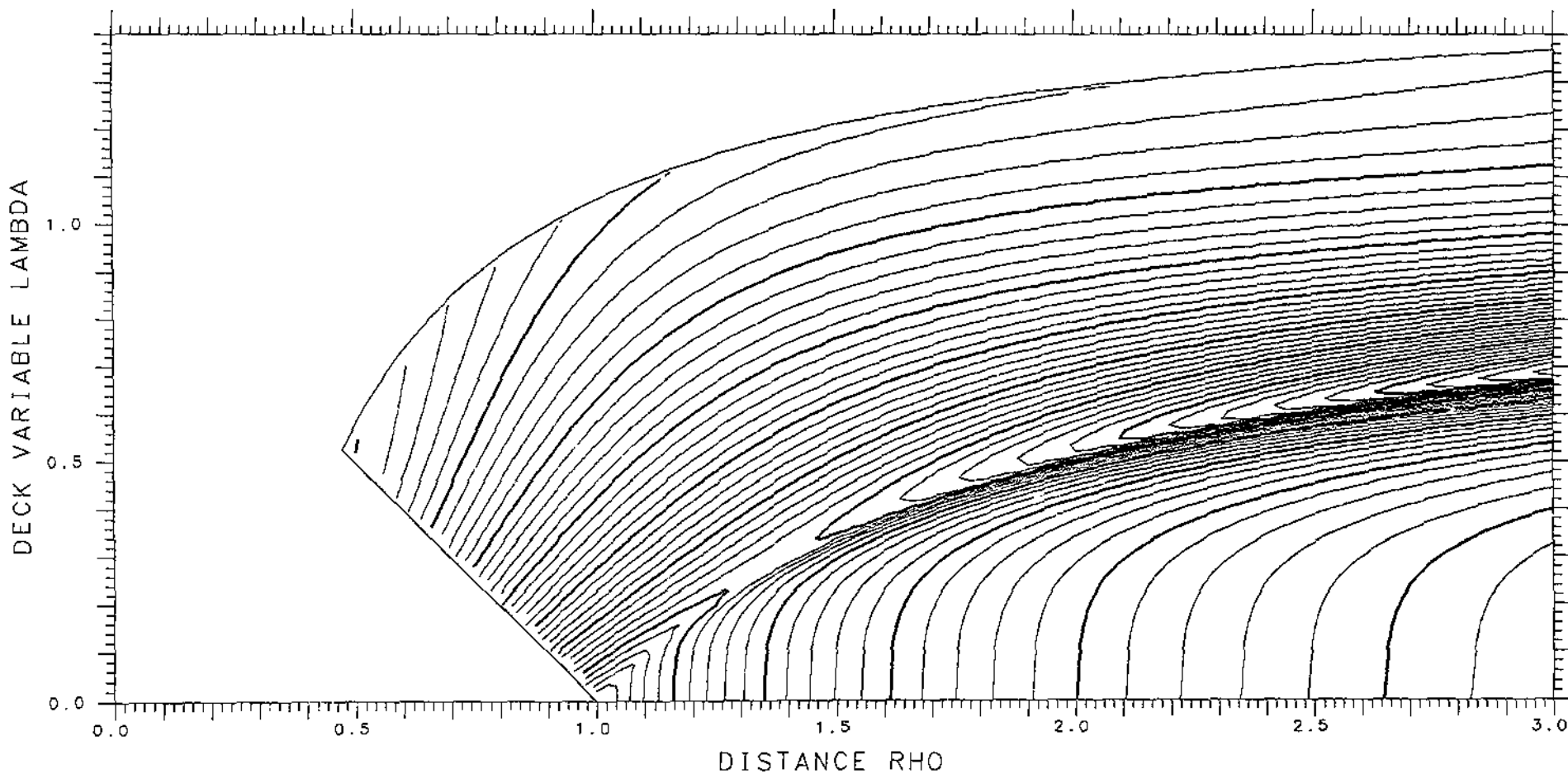

X= .675

ASYMMETRY DELTA= .075

FRACTIONAL= .6108

SPHERES -.22334

TANGENT .11548

LENGTH 11.294

ENERGY 568.61

SPACING .002

SADDLE .03530

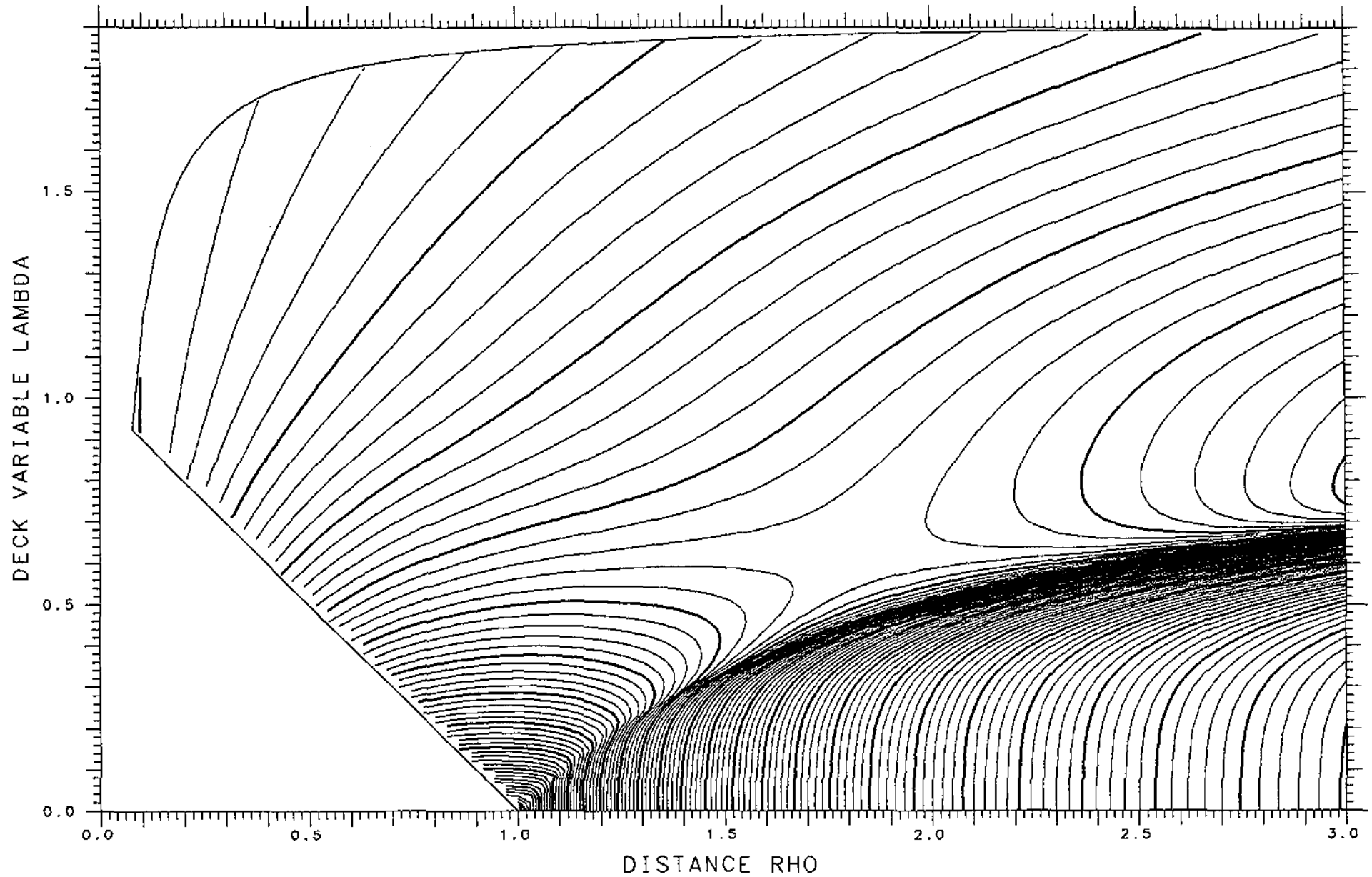

X= .800 ASYMMETRY DELTA= .450 FRACTIONAL= .9483

SPHERES -.02004 TANGENT .07653 LENGTH 10.381 ENERGY 641.16 SPACING .002 SADDLE .06131

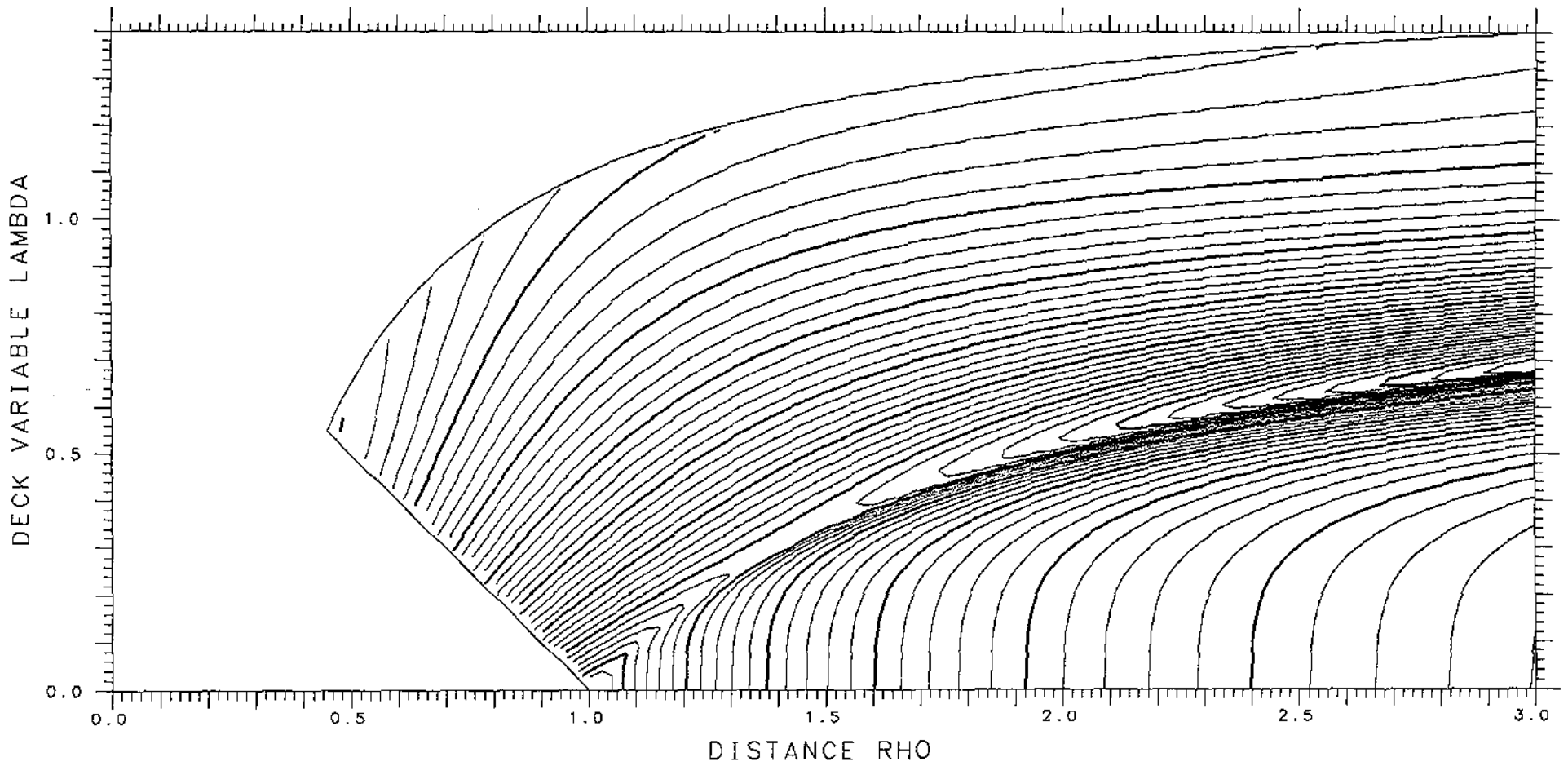

X= .675 ASYMMETRY DELTA= .100 FRACTIONAL= .6461

SPHERES - .21138 TANGENT .11592 LENGTH 11.246 ENERGY 568.61 SPACING .002 SADDLE .03803

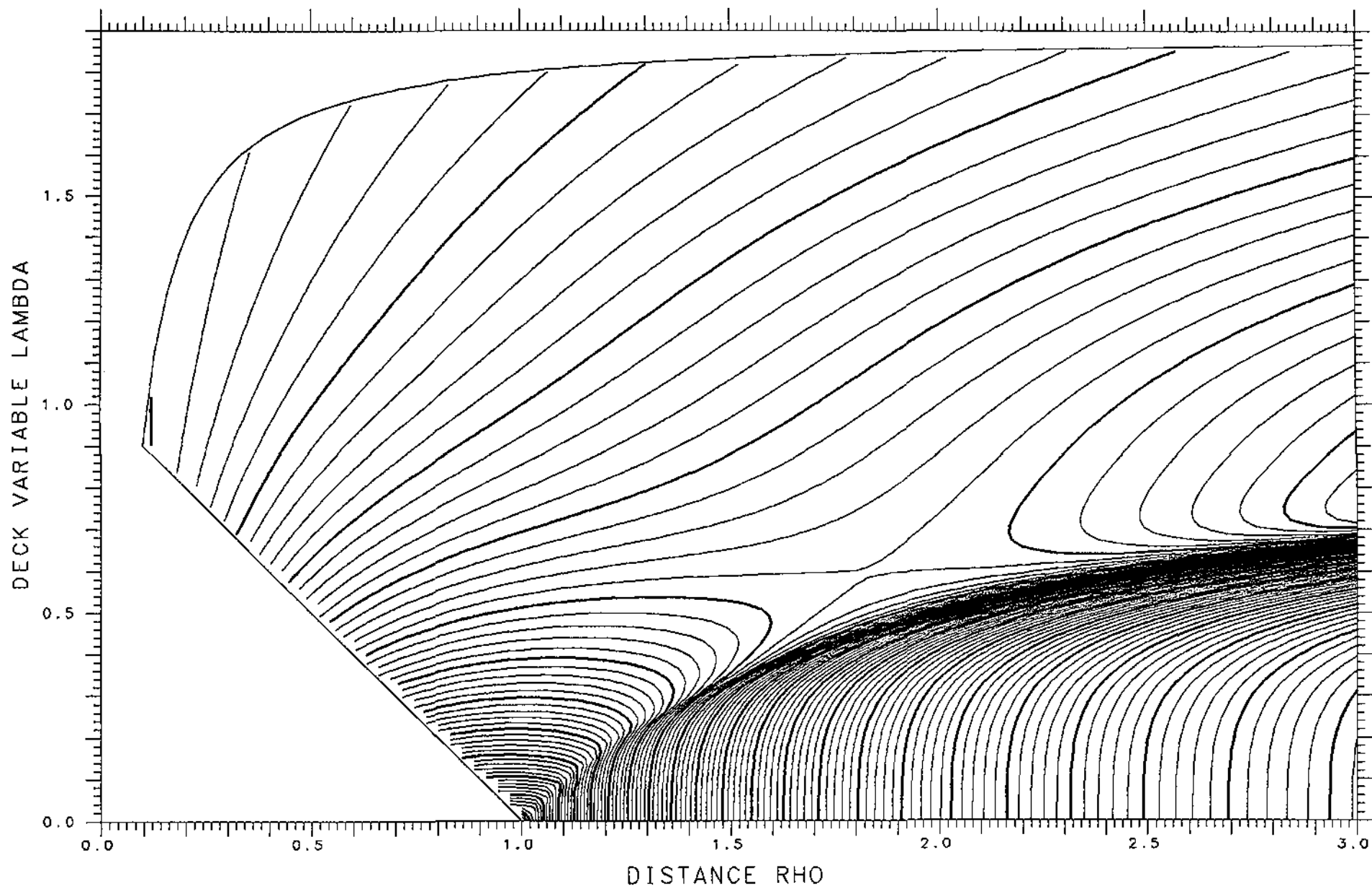

X= .800 ASYMMETRY DELTA= .425 FRACTIONAL= .9384

SPHERES -.03108 TANGENT .08119 LENGTH 10.526 ENERGY 641.16 SPACING .002 SADDLE .06197

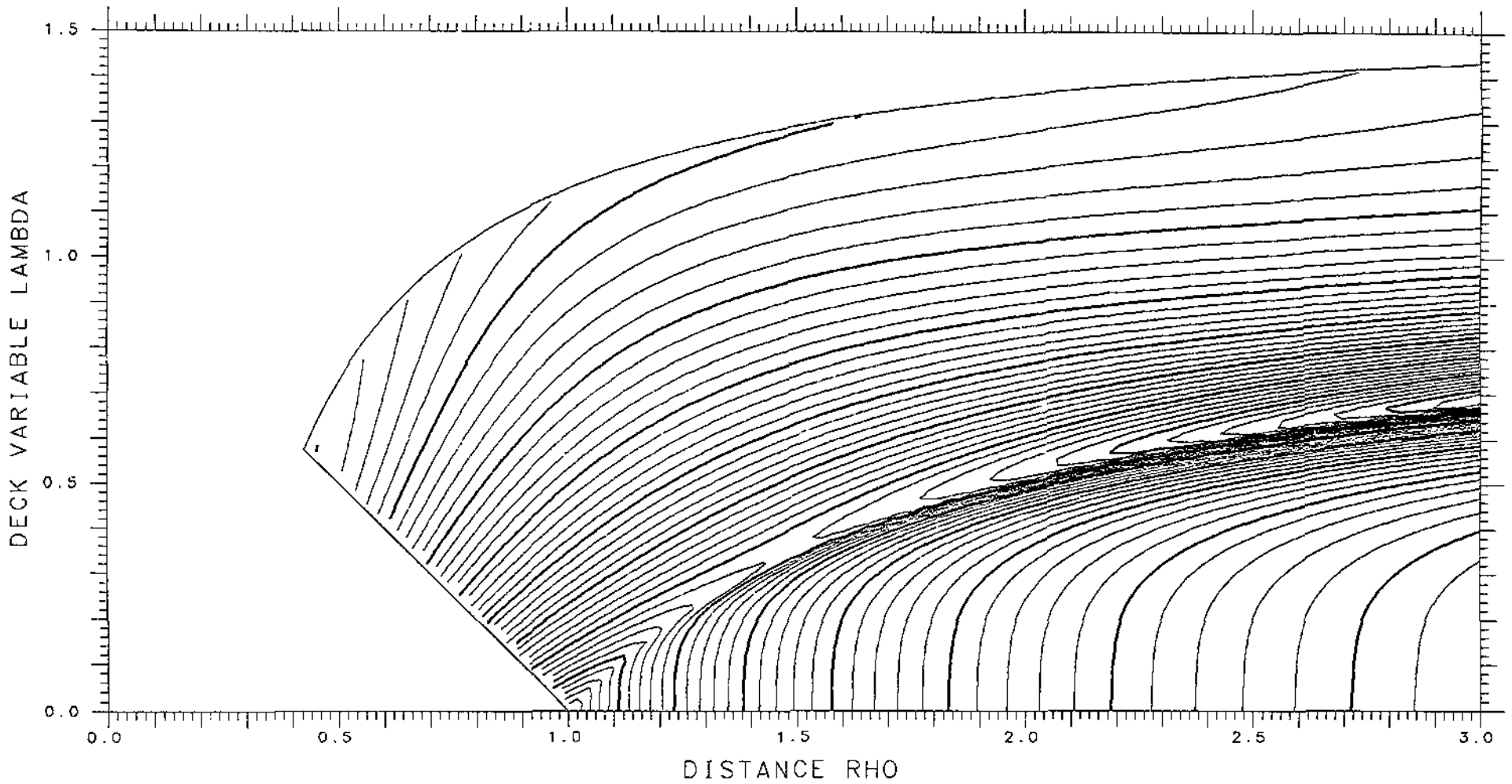

X= .675 ASYMMETRY DELTA= .125 FRACTIONAL= .6800

SPHERES -.19687 TANGENT .11628 LENGTH 11.185 ENERGY 568.61 SPACING .002 SADDLE .04165

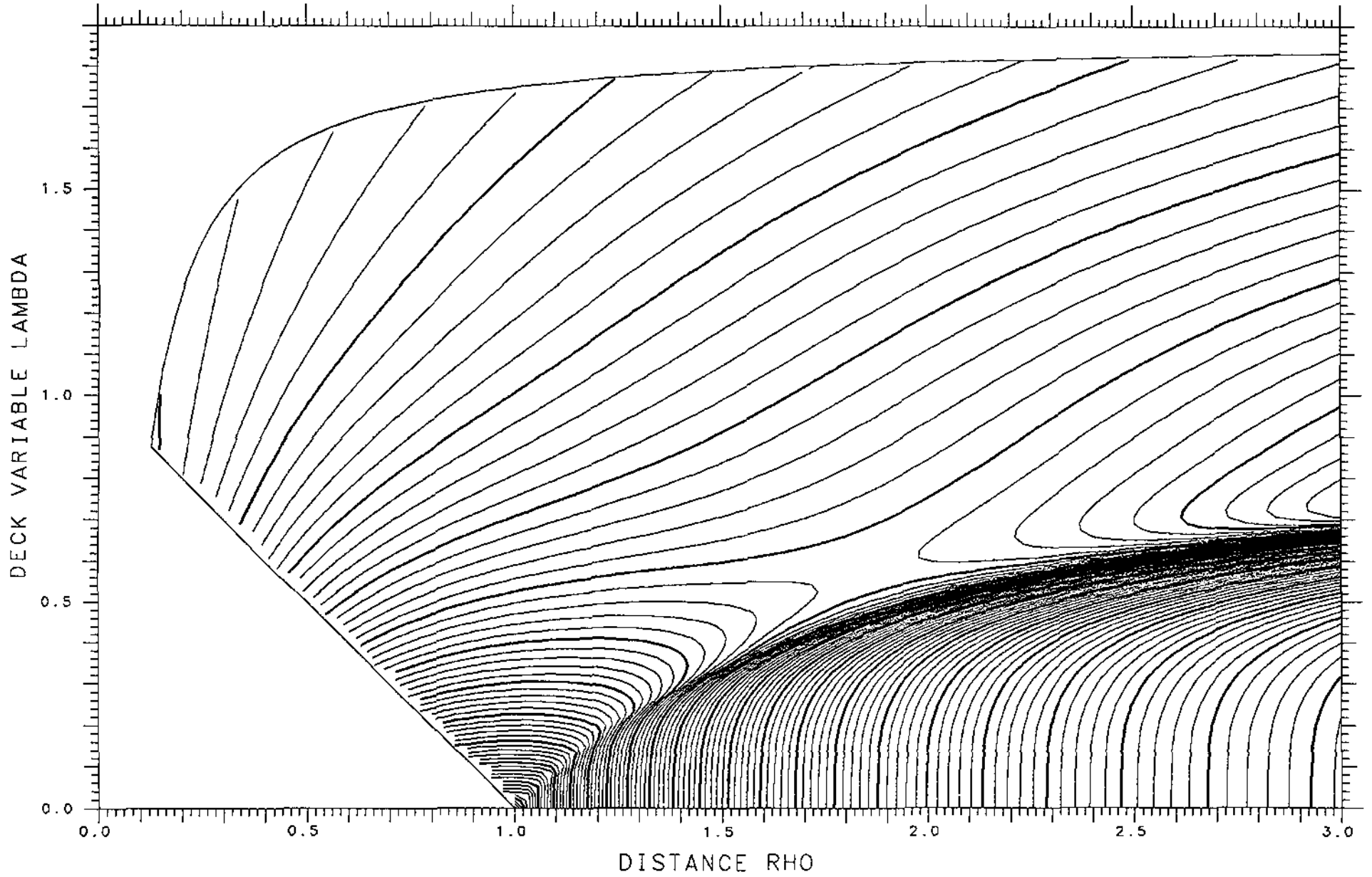

X= .800 ASYMMETRY DELTA= .400 FRACTIONAL= .9270

SPHERES -.04407 TANGENT .08544 LENGTH 10.671 ENERGY 641.16 SPACING .002 SADDLE .06150

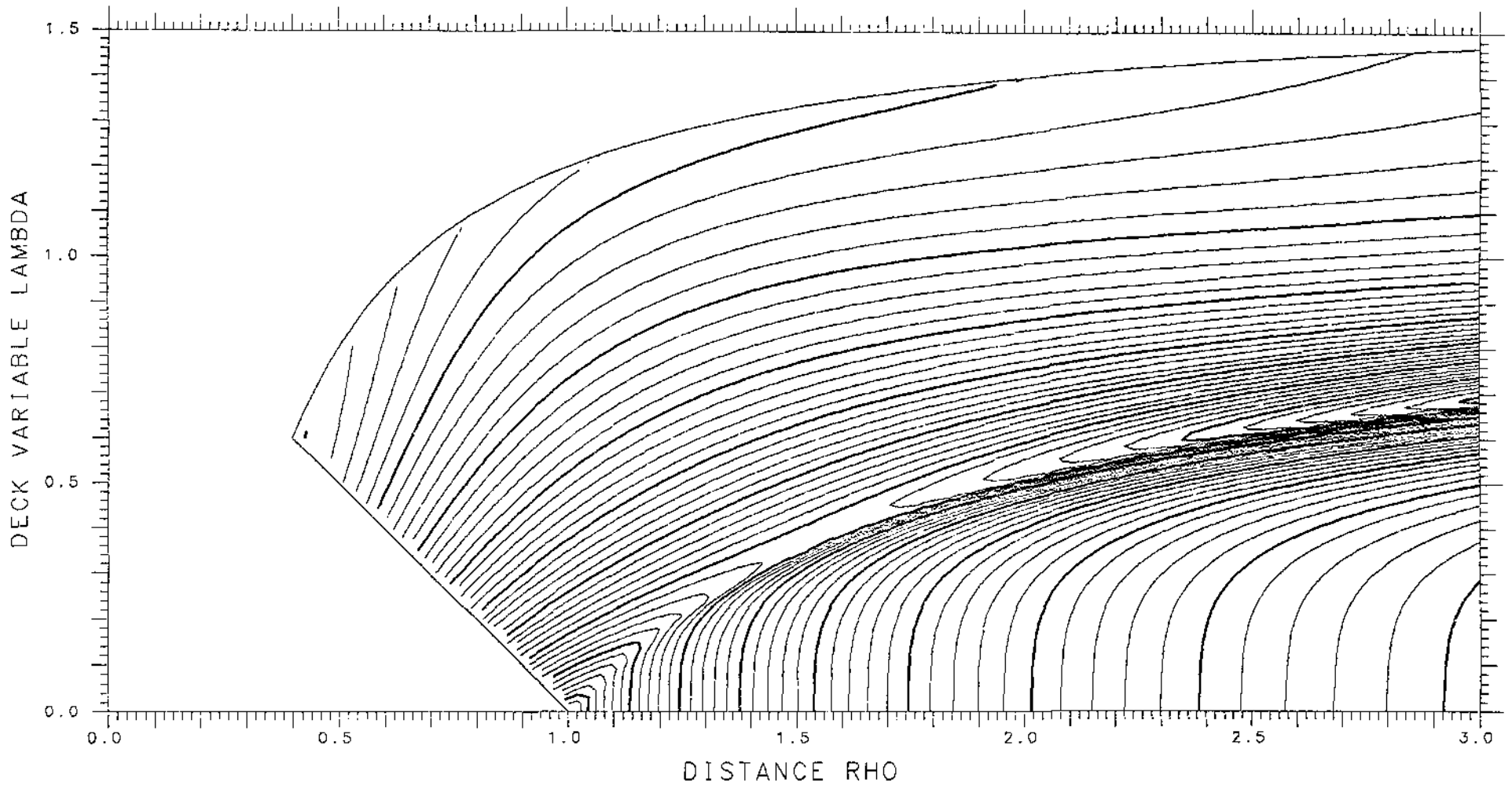

X= .675 ASYMMETRY DELTA= .150 FRACTIONAL= .7124

SPHERES -.18036 TANGENT .11647 LENGTH 11.112 ENERGY 568.61 SPACING .002 SADDLE .04599

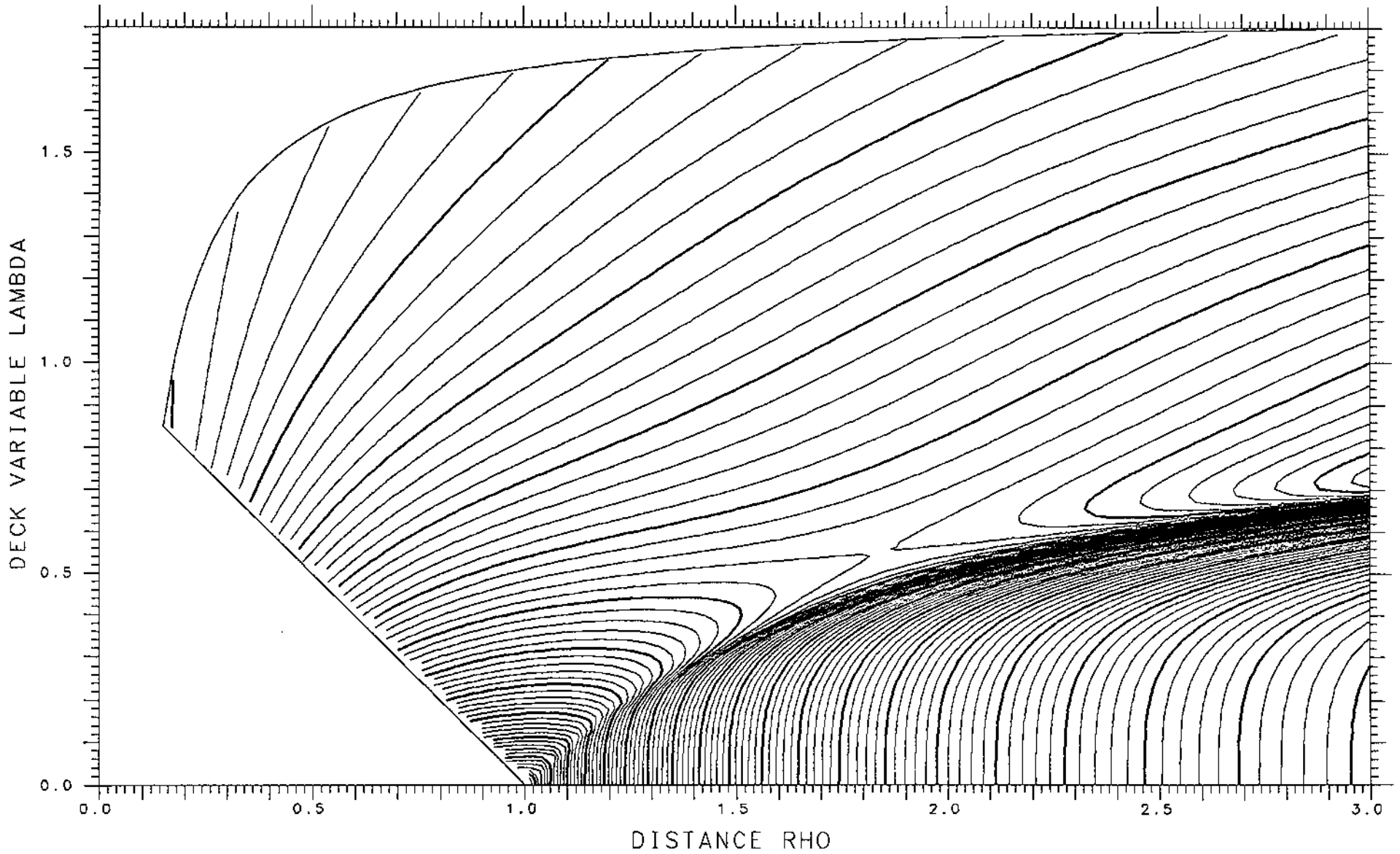

X= .800 ASYMMETRY DELTA= .375 FRACTIONAL= .9141

SPHERES -.05907 TANGENT .08919 LENGTH 10.814 ENERGY 641.16 SPACING .002 SADDLE .05977

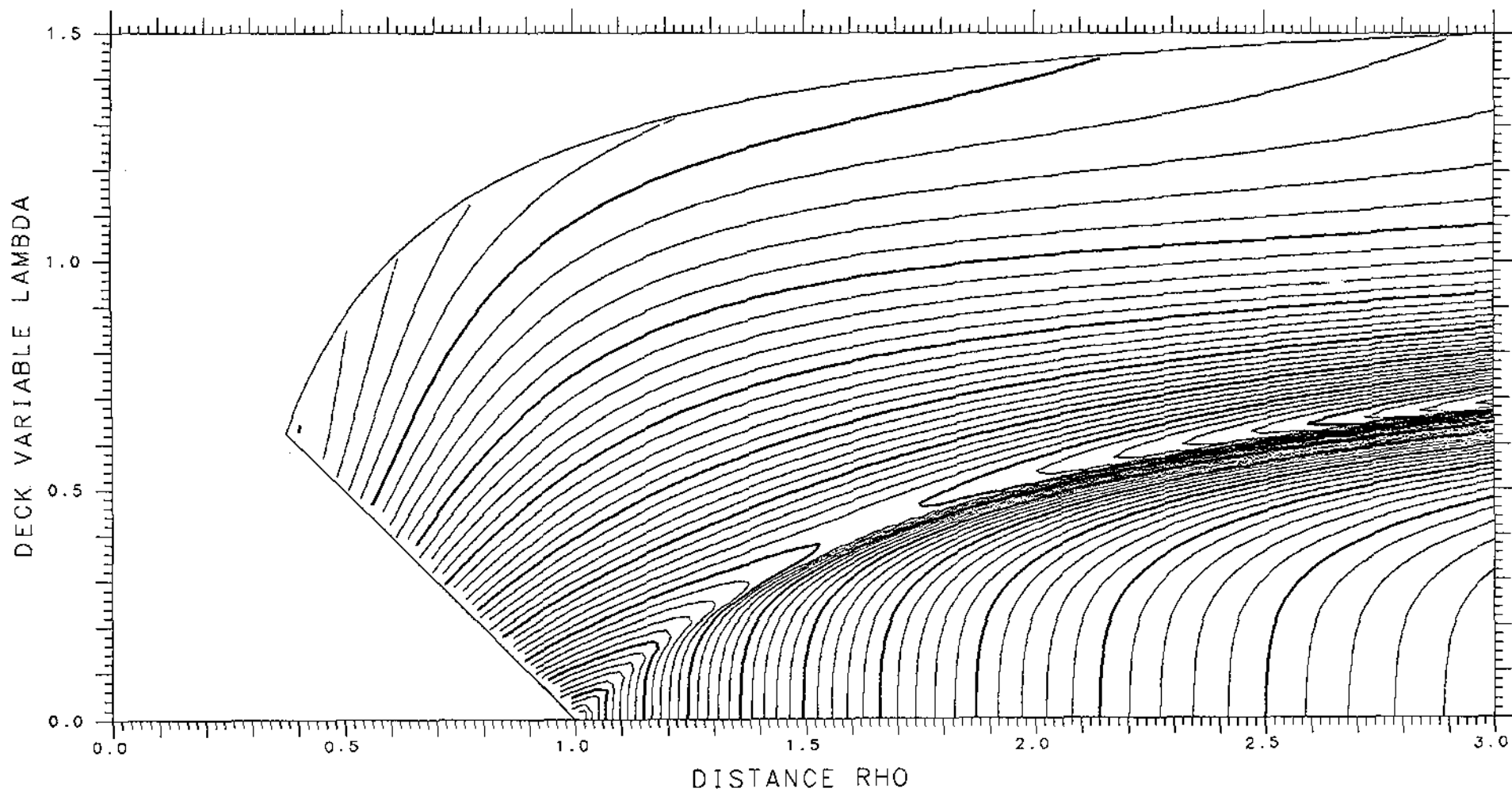

X= .675 ASYMMETRY DELTA= .175 FRACTIONAL= .7429

SPHERES -.16244 TANGENT .11636 LENGTH 11.029 ENERGY 568.61 SPACING .002 SADDLE .05081

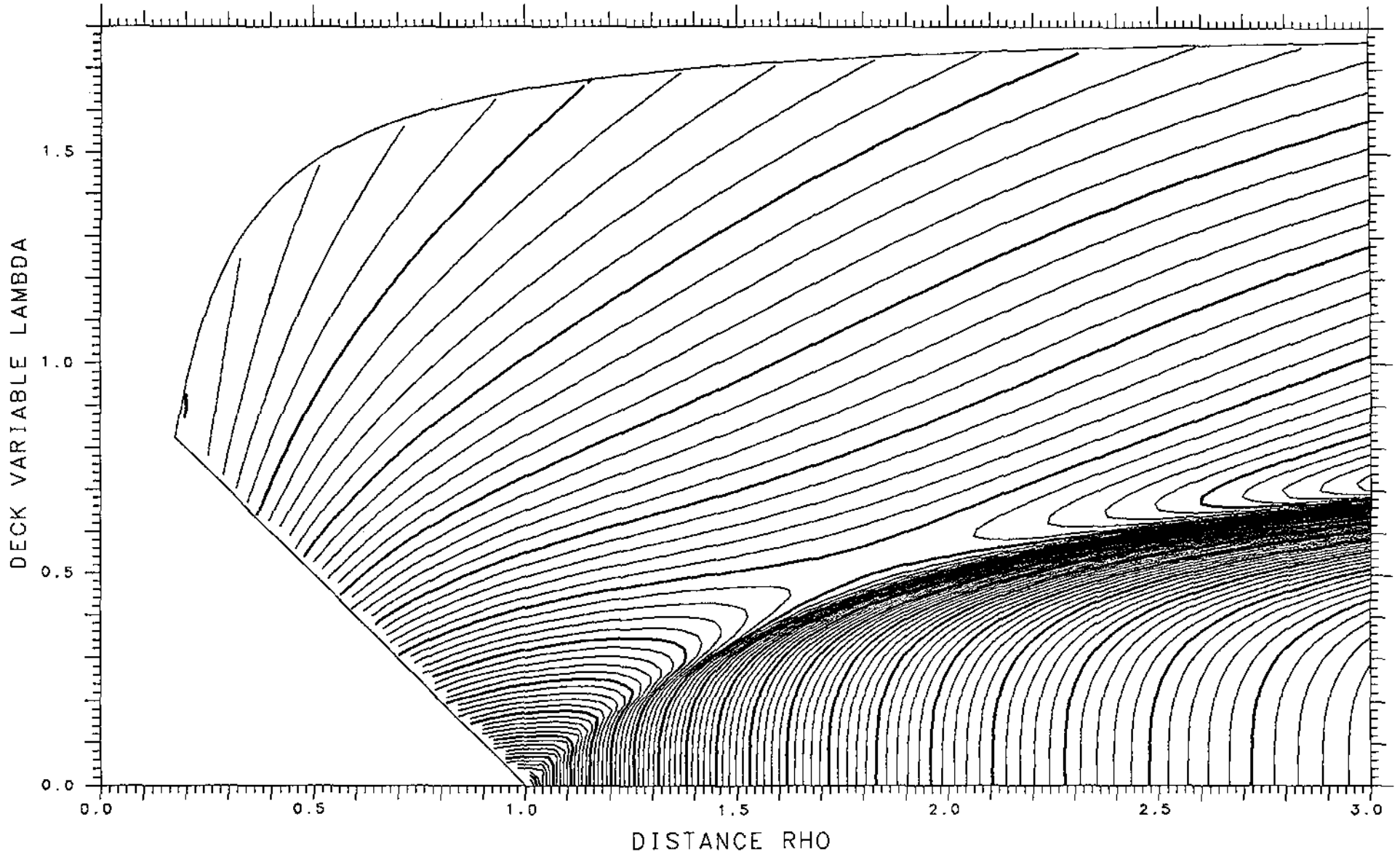

X= .800 ASYMMETRY DELTA= .350 FRACTIONAL= .8996

SPHERES -.07607 TANGENT .09236 LENGTH 10.956 ENERGY 641.16 SPACING .002 SADDLE .05671

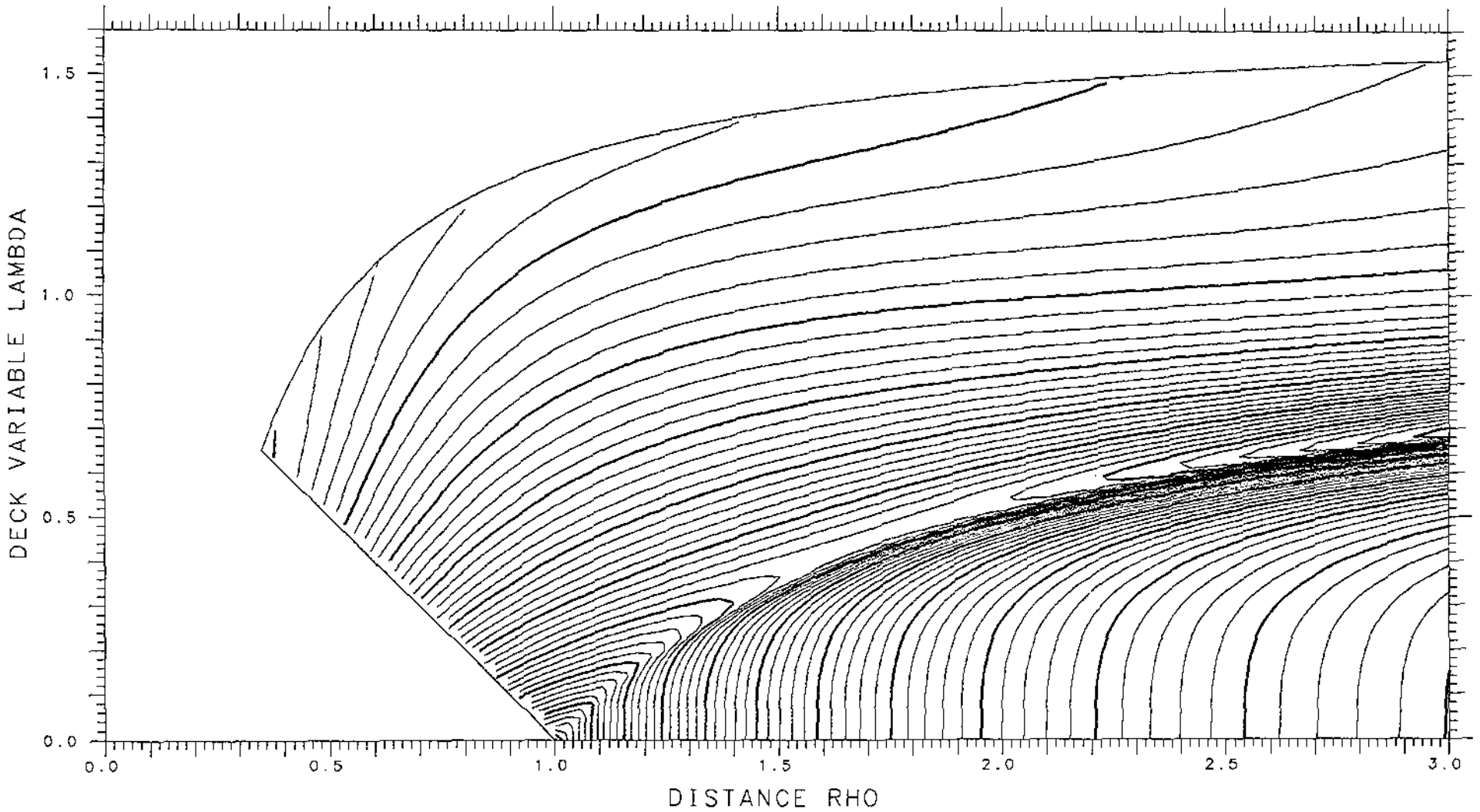

X= .675 ASYMMETRY DELTA= .200 FRACTIONAL= .7714

SPHERES -.14370 TANGENT .11585 LENGTH 10.936 ENERGY 568.61 SPACING .002 SADDLE .05582

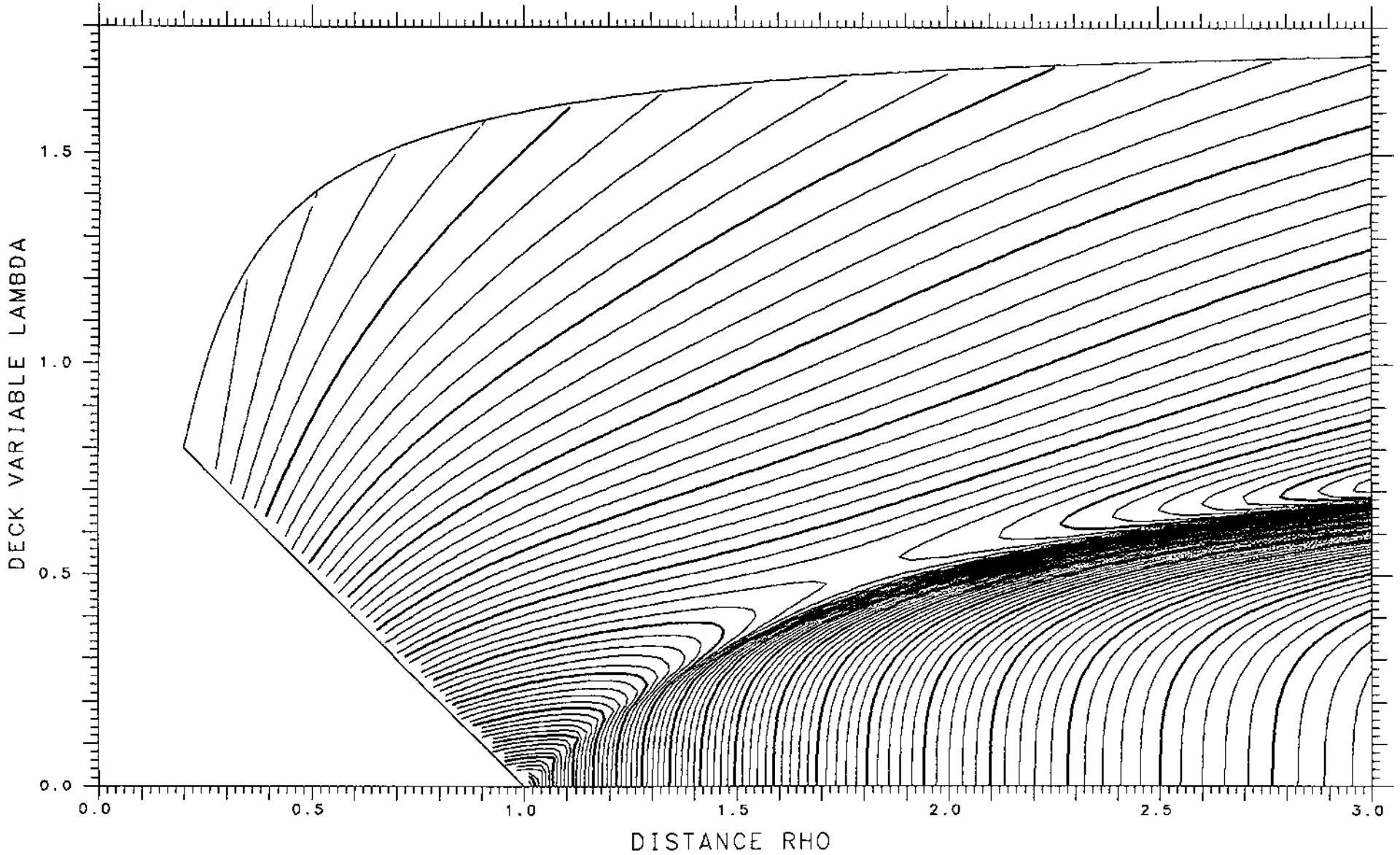

X= .800 ASYMMETRY DELTA= .325 FRACTIONAL= .8832

SPHERES -.09501 TANGENT .09489 LENGTH 11.094 ENERGY 641.16 SPACING .002 SADDLE .05229

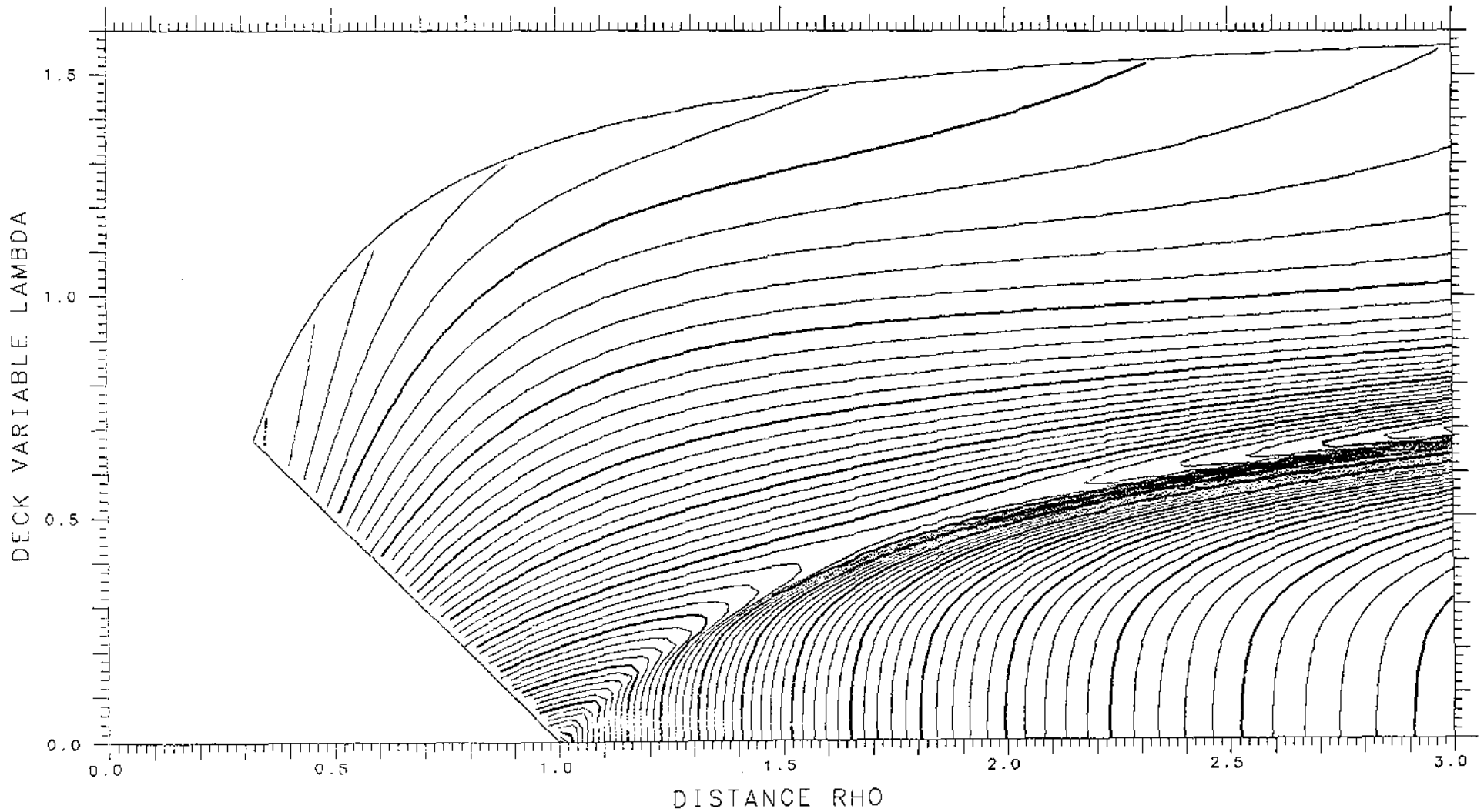

X= .675 ASYMMETRY DELTA= .225 FRACTIONAL= .7979

SPHERES -.12471 TANGENT .11485 LENGTH 10.834 ENERGY 568.61 SPACING .002 SADDLE .06070

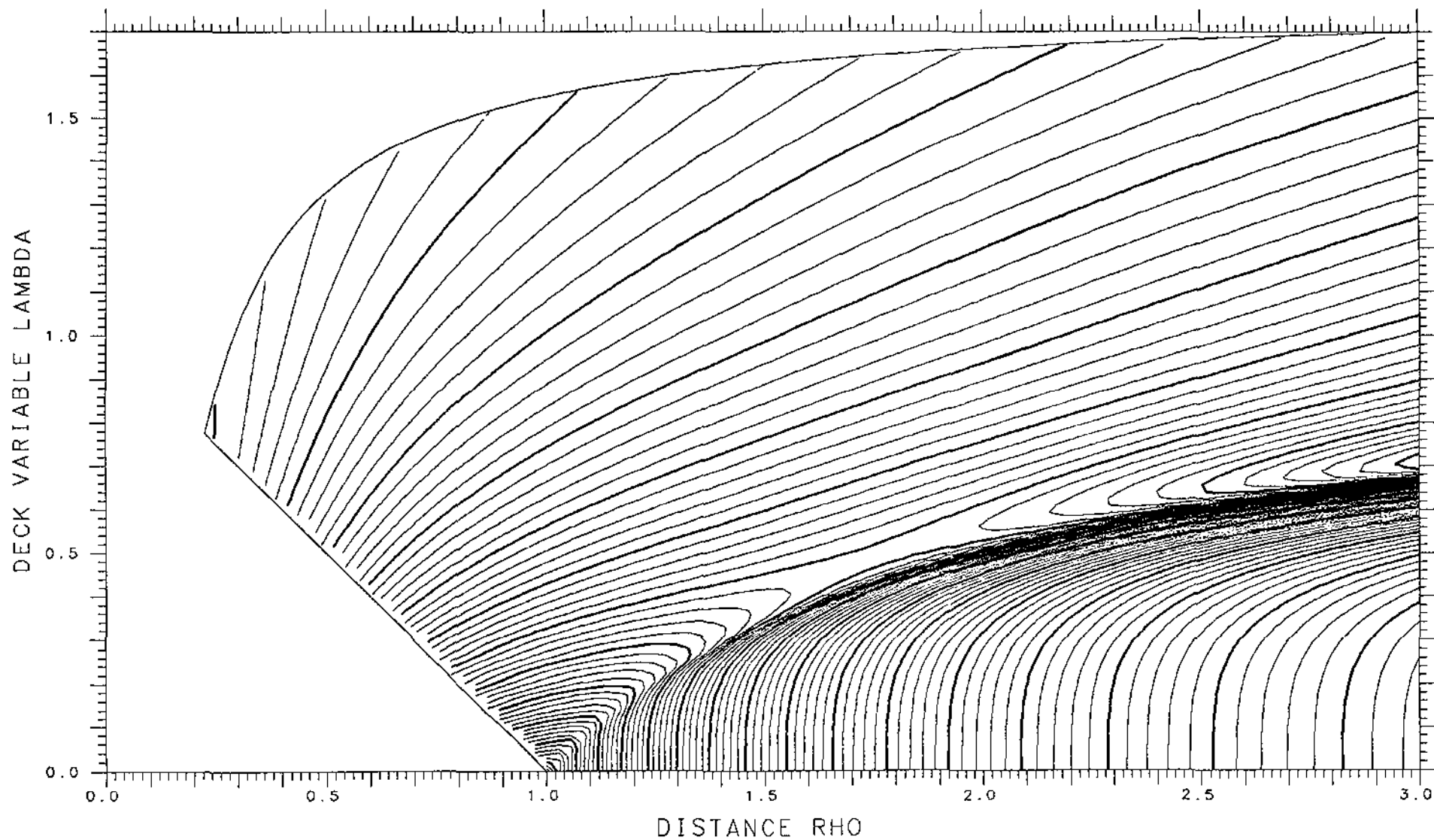

X= .800 ASYMMETRY DELTA= .300 FRACTIONAL= .8650

SPHERES -.11574 TANGENT .09675 LENGTH 11.229 ENERGY 641.16 SPACING .002 SADDLE .04658

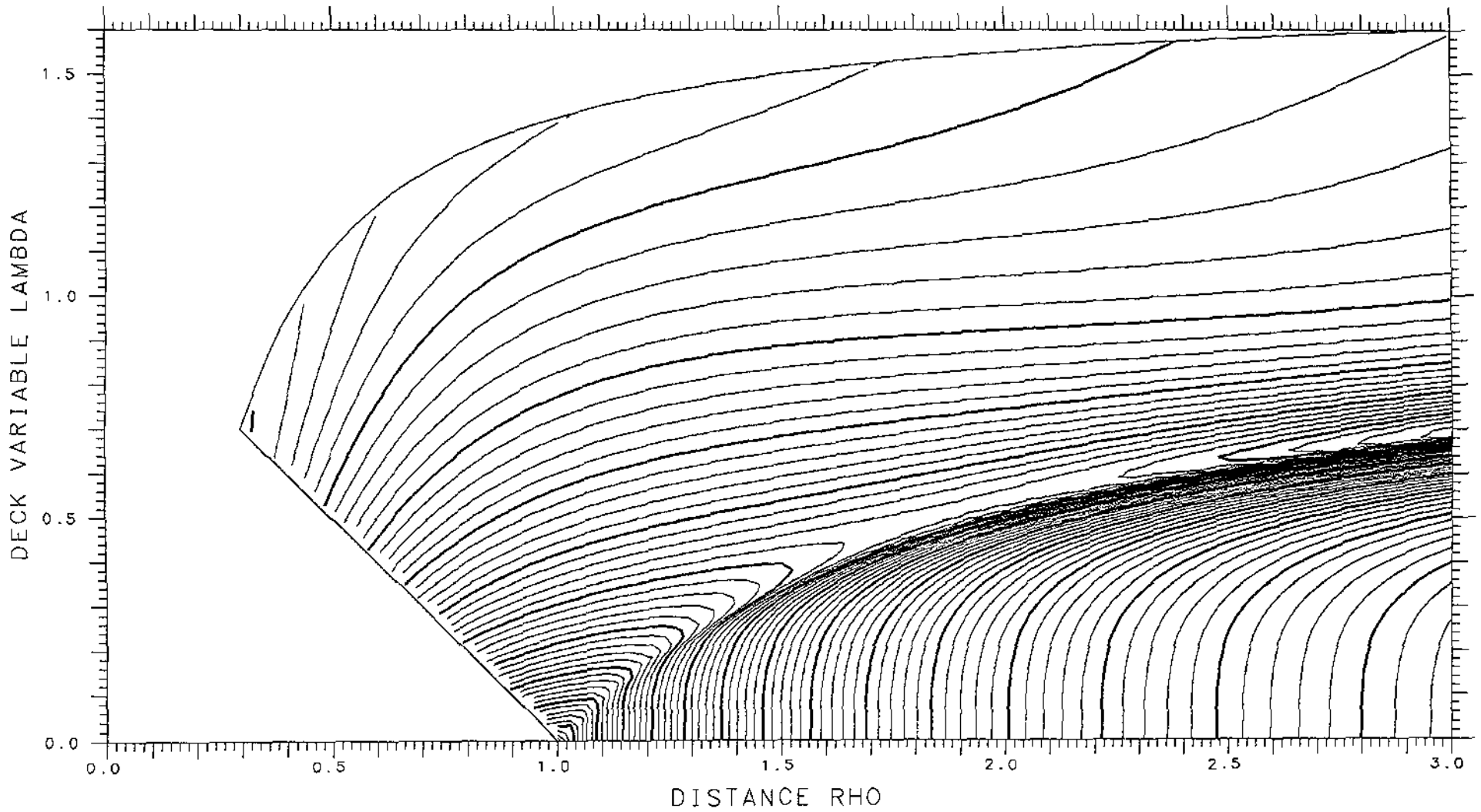

X= .675 ASYMMETRY DELTA= .250 FRACTIONAL= .8224

SPHERES -.10597 TANGENT .11329 LENGTH 10.725 ENERGY 568.61 SPACING .002 SADDLE .06517

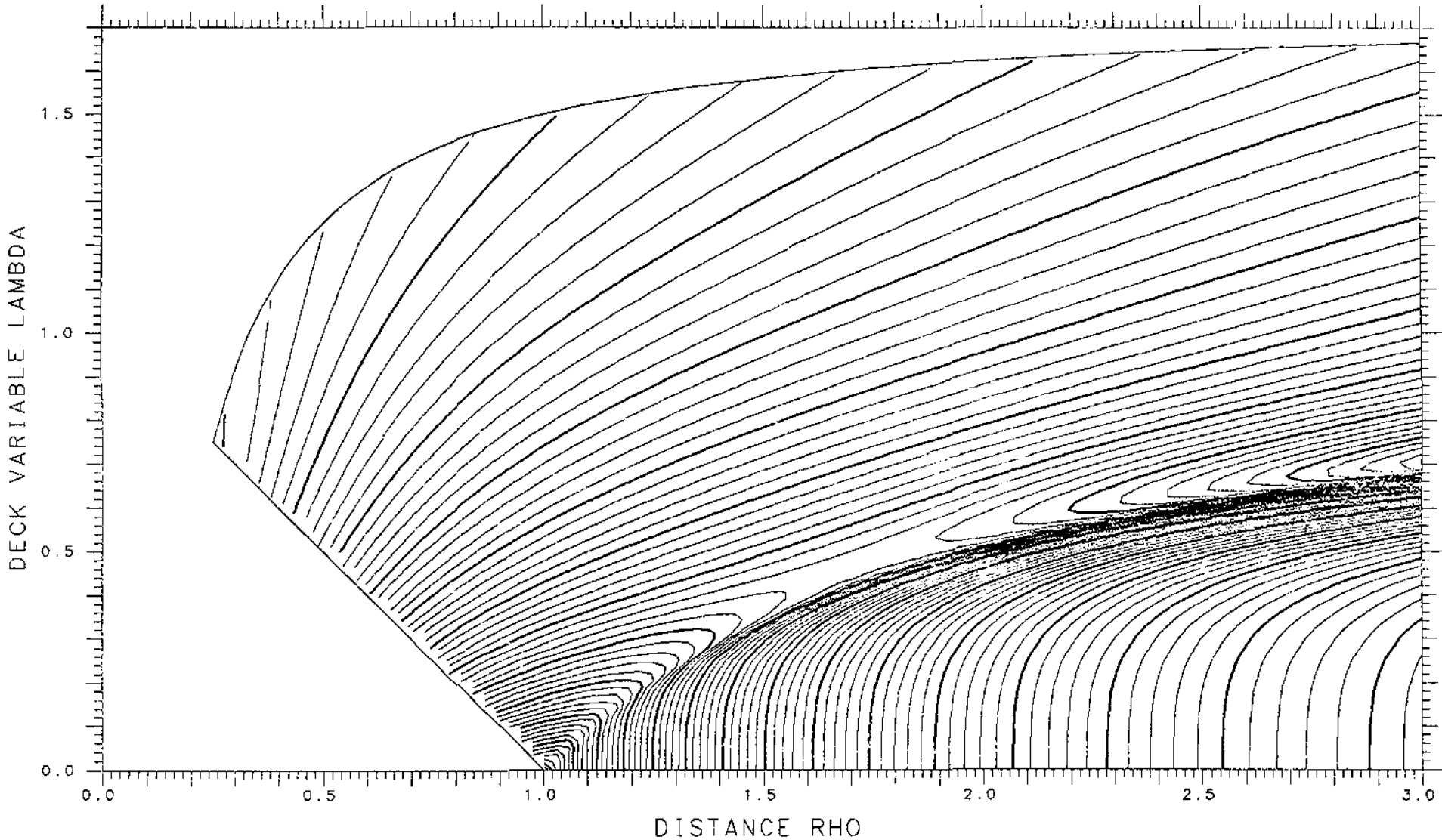

X= .800 ASYMMETRY DELTA= .275 FRACTIONAL= .8447

SPHERES -.13801 TANGENT .09791 LENGTH 11.359 ENERGY 641.16 SPACING .002 SADDLE .03973

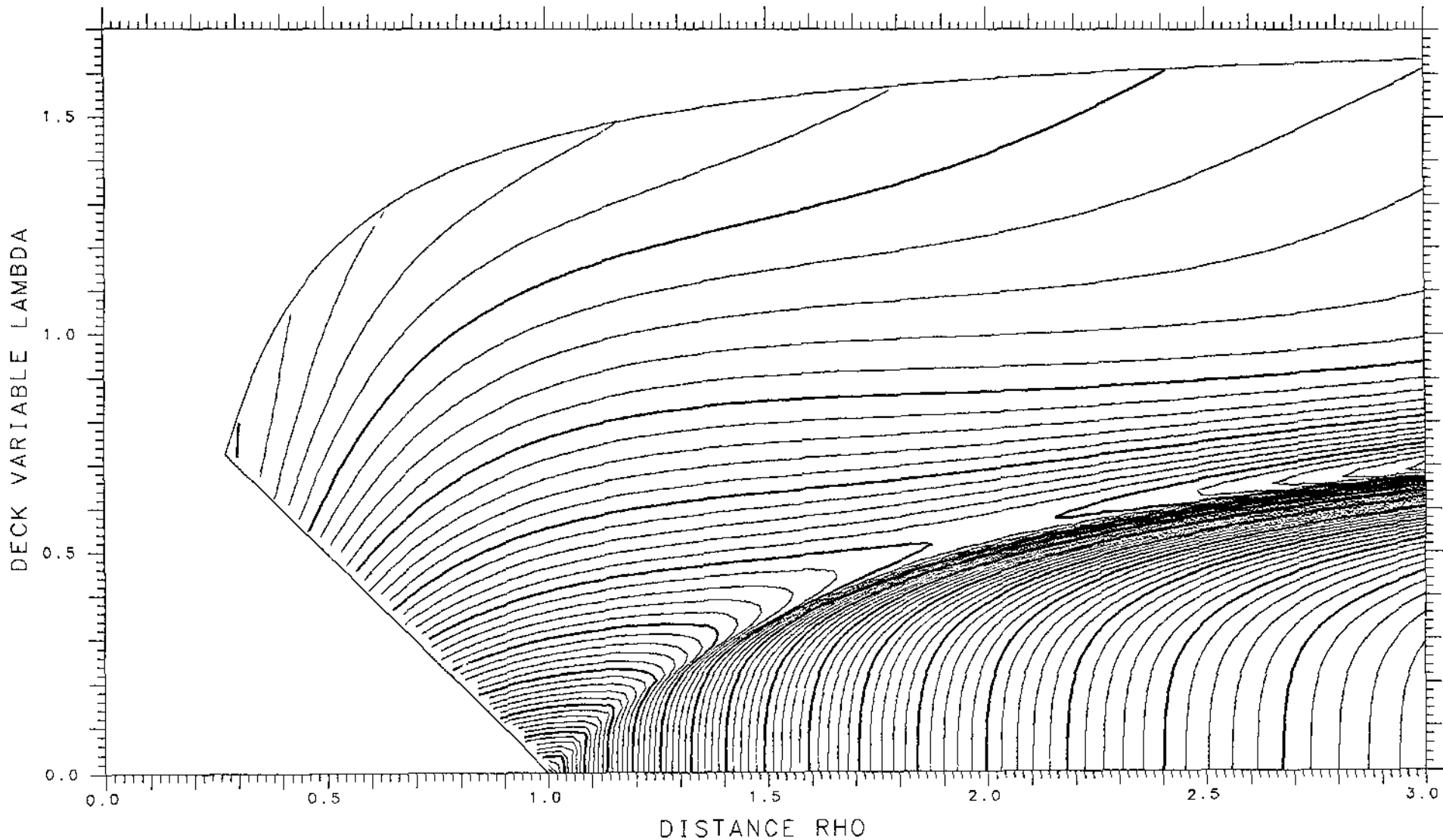

X= .675 ASYMMETRY DELTA= .275 FRACTIONAL= .8447

SPHERES -.08793 TANGENT .11113 LENGTH 10.609 ENERGY 568.61 SPACING .002 SADDLE .06900

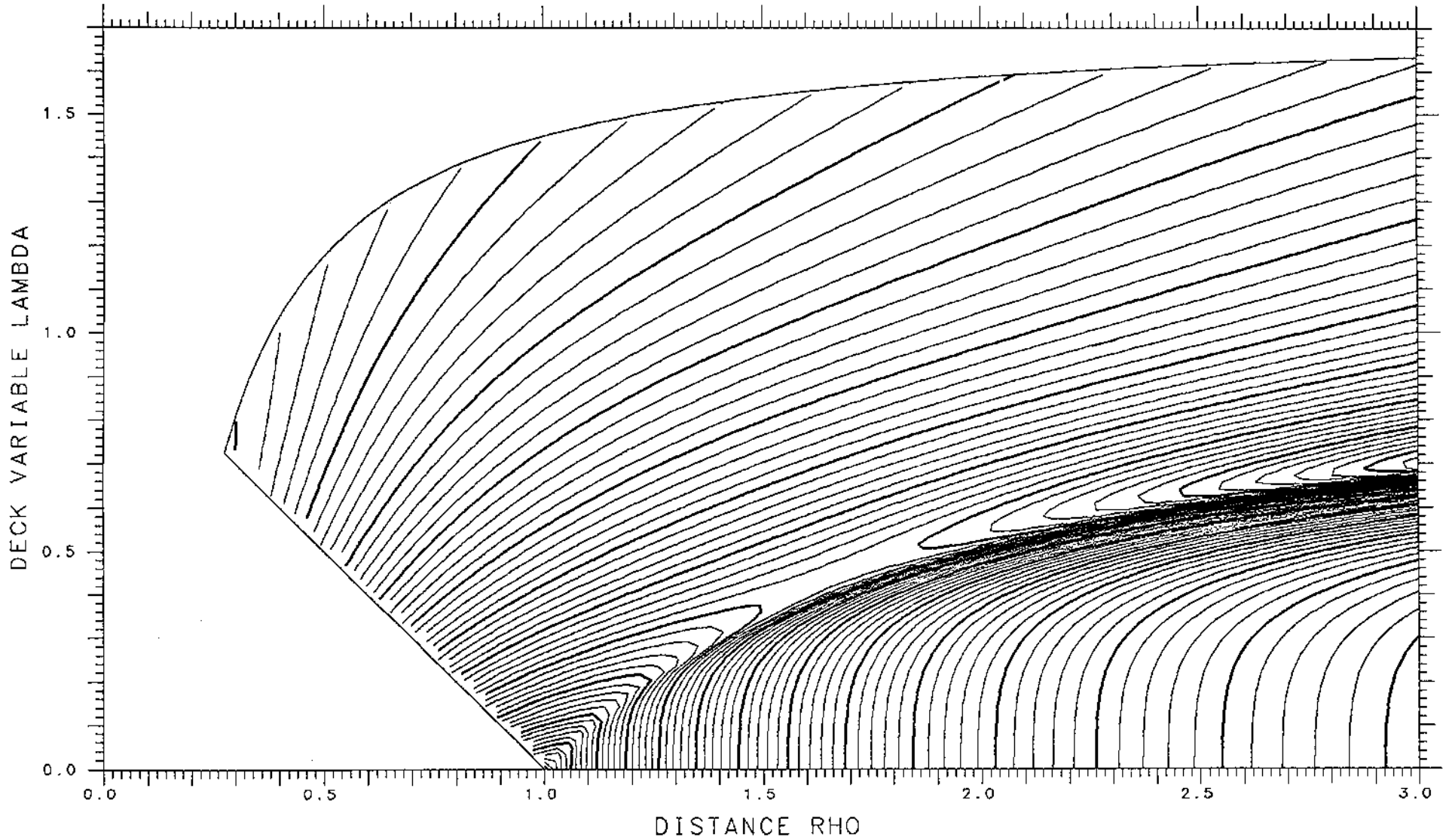

X= .600 ASYMMETRY DELTA= .250 FRACTIONAL= .8224

SPHERES -.16142 TANGENT .09638 LENGTH 11.483 ENERGY 641.16 SPACING .002 SADDLE .03198

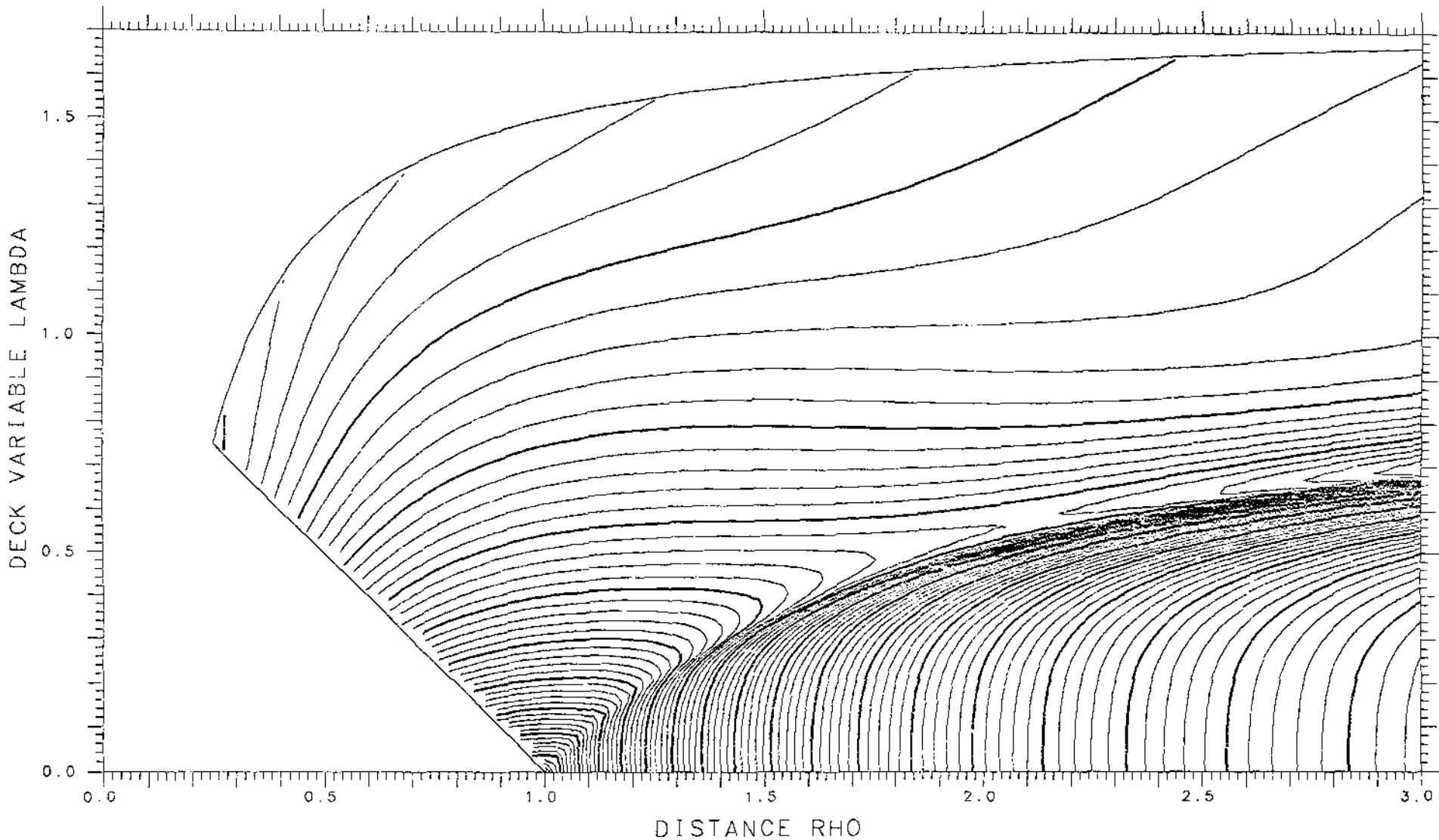

X= .675 ASYMMETRY DELTA= .300 FRACTIONAL= .8650

SPHERES -.07093 TANGENT .10836 LENGTH 10.487 ENERGY 568.61 SPACING .002 SADDLE .07199

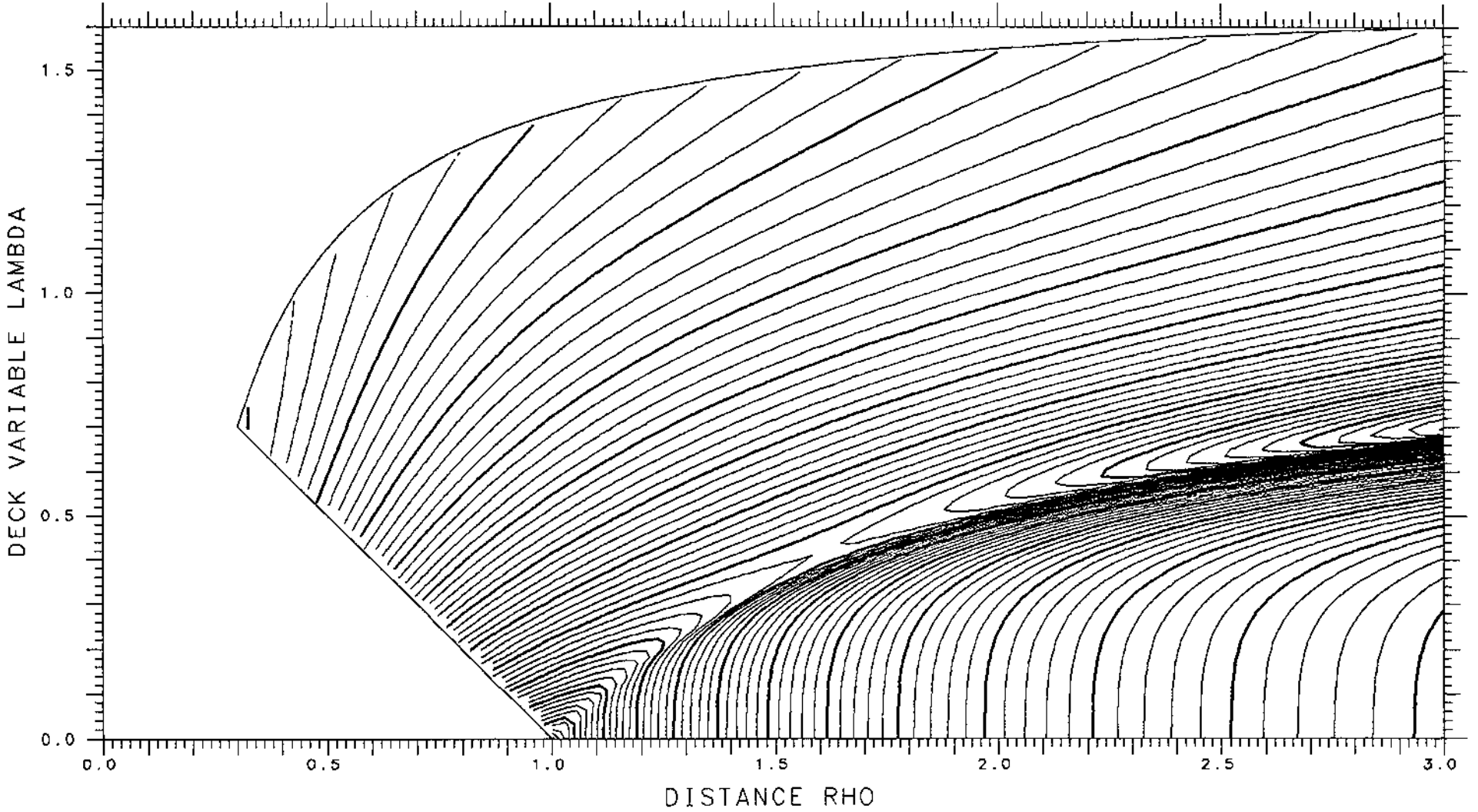

X= .800 ASYMMETRY DELTA= .225 FRACTIONAL= .7979

SPHERES -.18570 TANGENT .09822 LENGTH 11.601 ENERGY 641.16 SPACING .002 SADDLE .02364

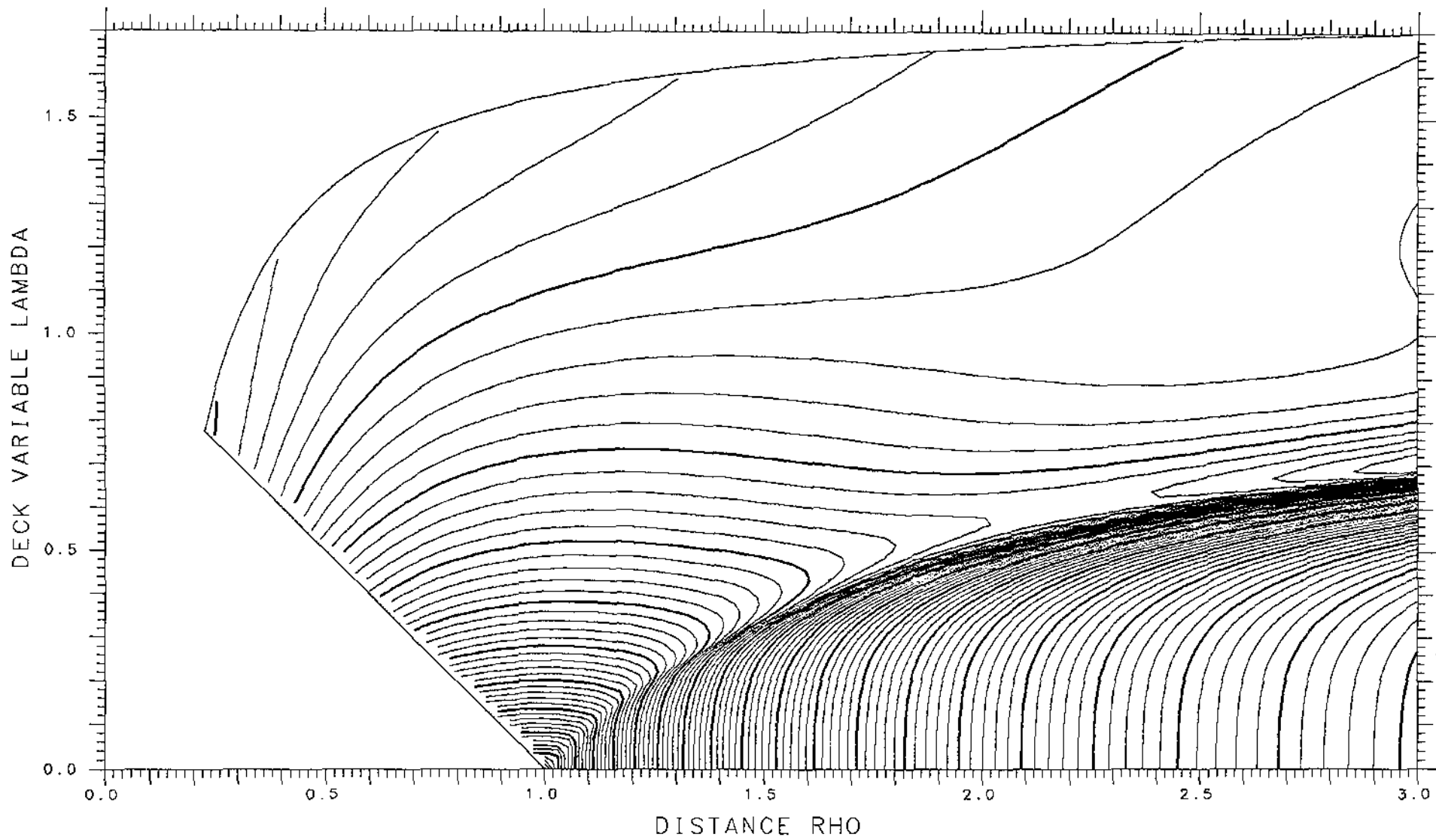

X= .675 ASYMMETRY DELTA= .325 FRACTIONAL= .8832

SPHERES -.05525 TANGENT .10498 LENGTH 10.361 ENERGY 568.61 SPACING .002 SADDLE .07403

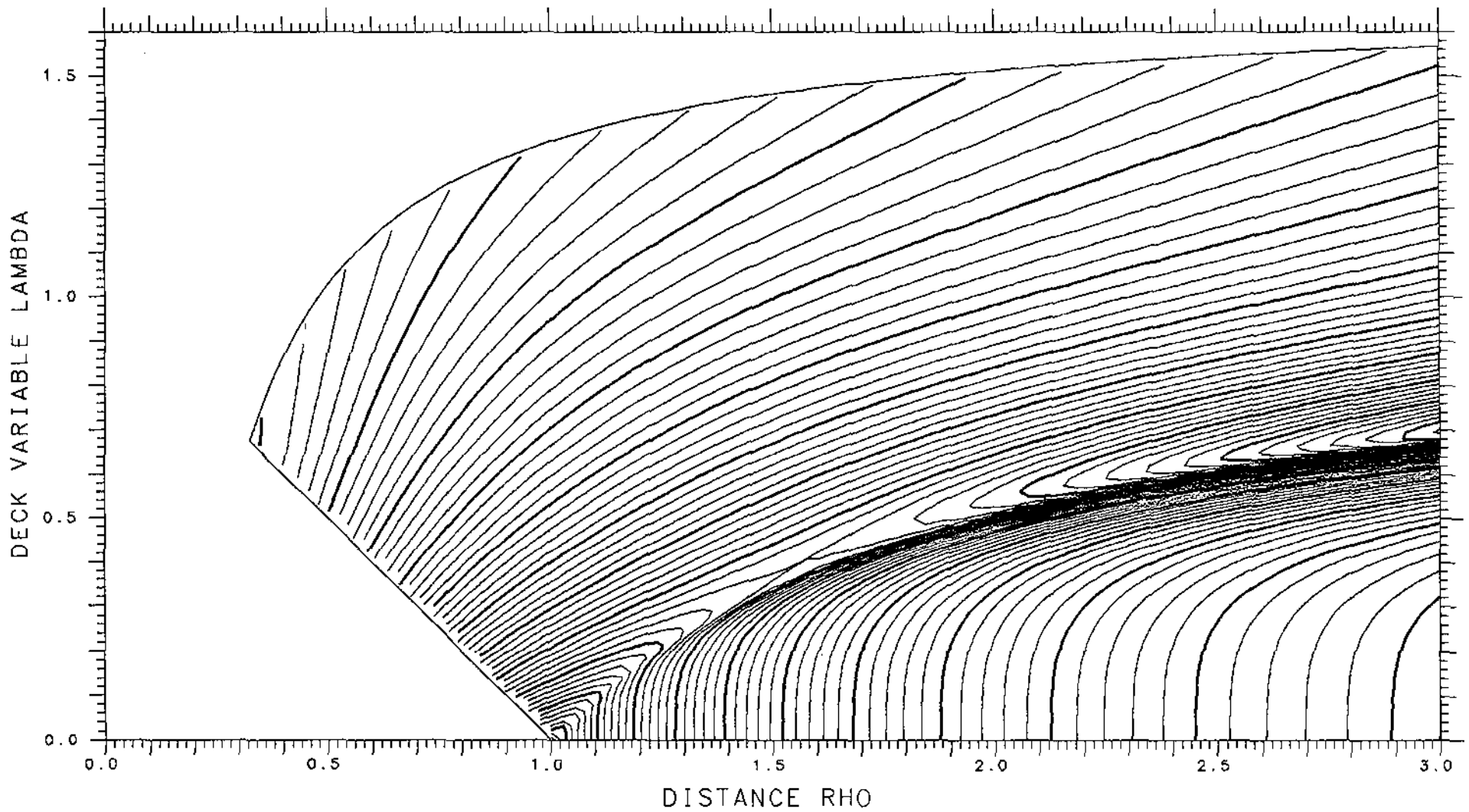

X= .800 ASYMMETRY DELTA= .200 FRACTIONAL= .7714

SPHERES -.21012 TANGENT .09749 LENGTH 11.710 ENERGY 641.16 SPACING .002 SADDLE .01515

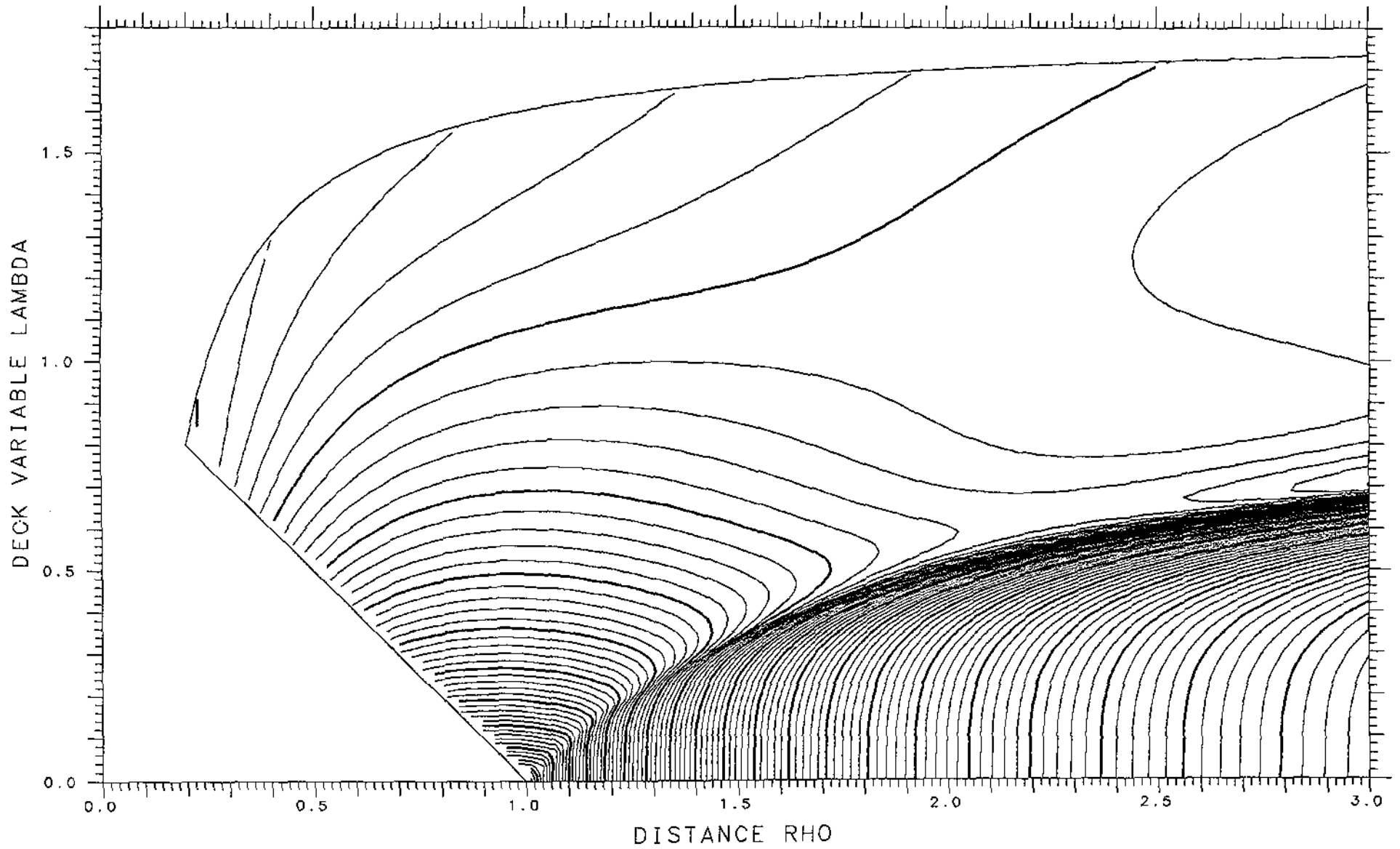

X= .675 ASYMMETRY DELTA= .350 FRACTIONAL= .8996

SPHERES -.04107 TANGENT .10104 LENGTH 10.232 ENERGY 568.61 SPACING .002 SADDLE .07506

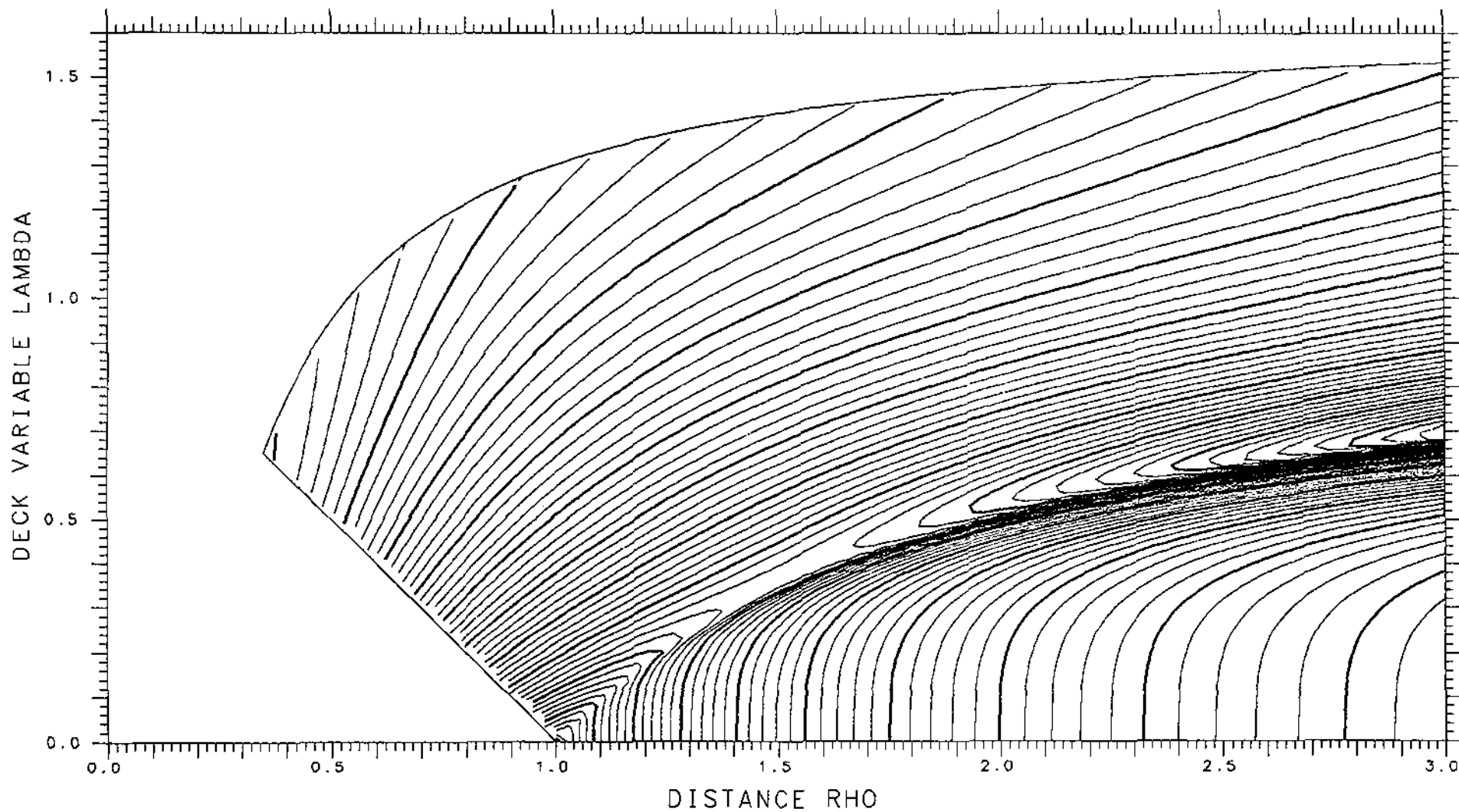

X= .800 ASYMMETRY DELTA= .175 FRACTIONAL= .7429

SPHERES -.23411 TANGENT .09632 LENGTH 11.809 ENERGY 641.16 SPACING .002 SADDLE .00713

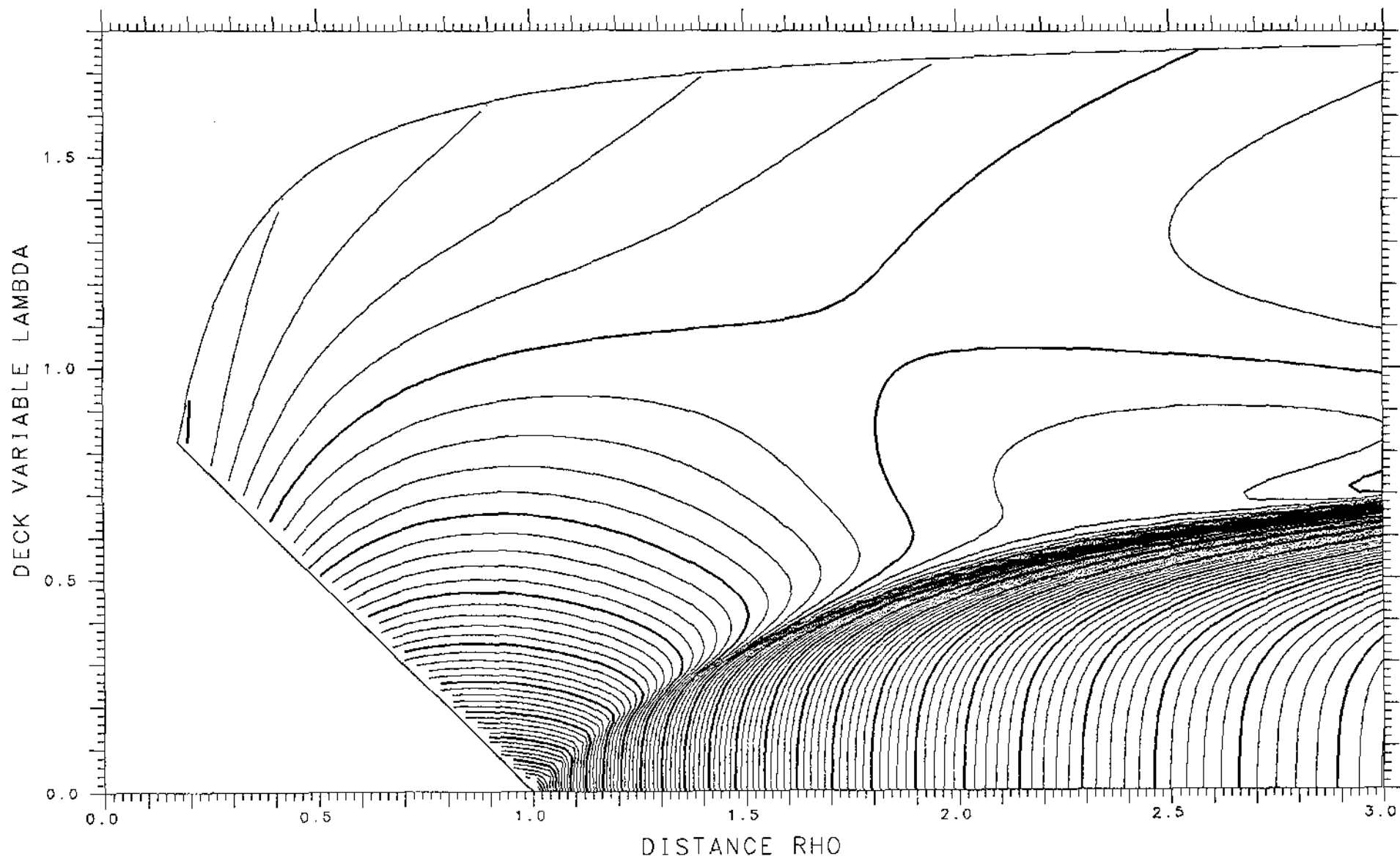

X= .675 ASYMMETRY DELTA= .375 FRACTIONAL= .9141

SPHERES -.02850 TANGENT .09658 LENGTH 10.100 ENERGY 568.61 SPACING .002 SADDLE .07507

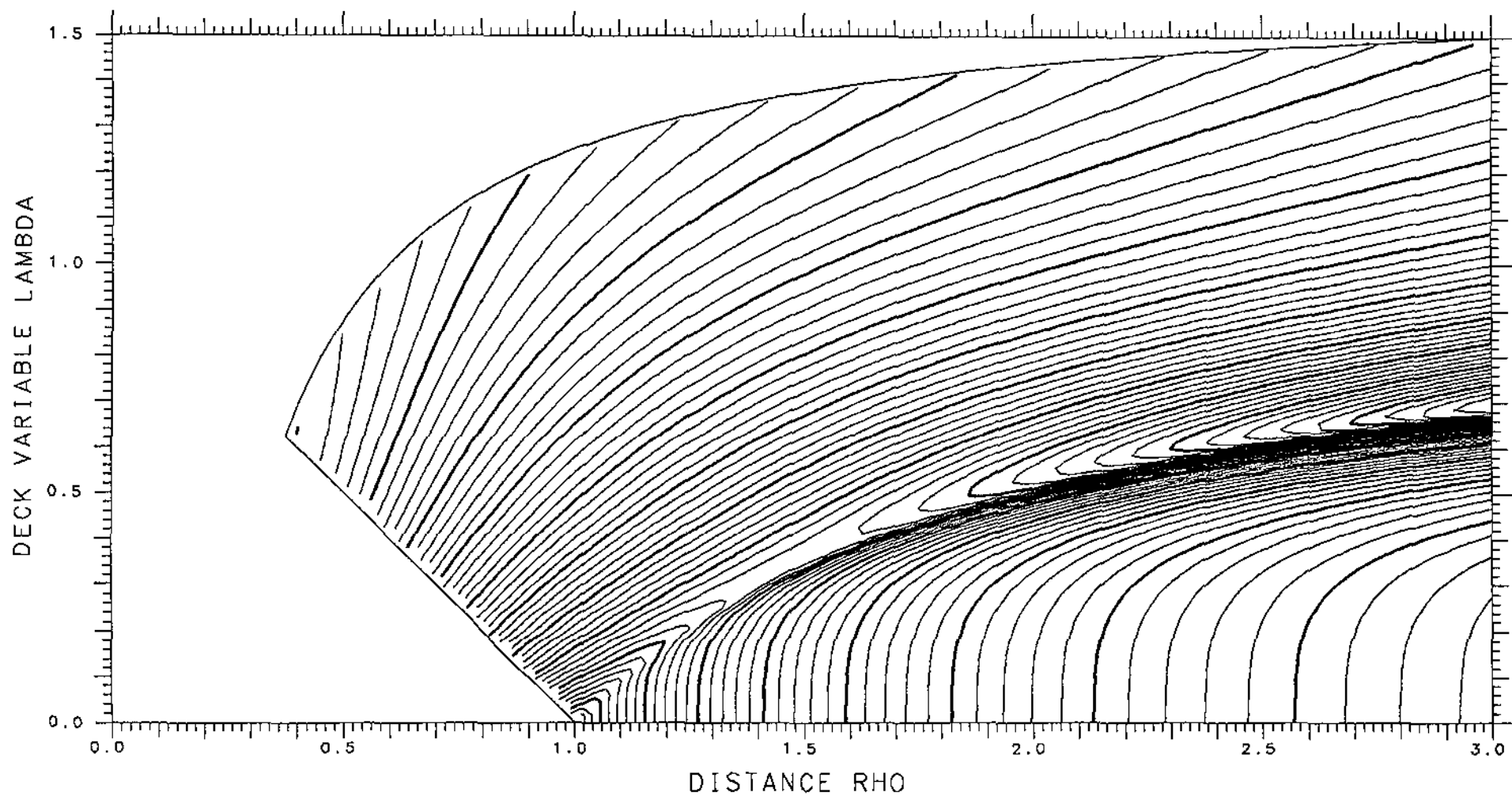

X= .800 ASYMMETRY DELTA= .150 FRACTIONAL= .7124

SPHERES -.25698 TANGENT .09462 LENGTH 11.898 ENERGY 641.16 SPACING .002 SADDLE .00927

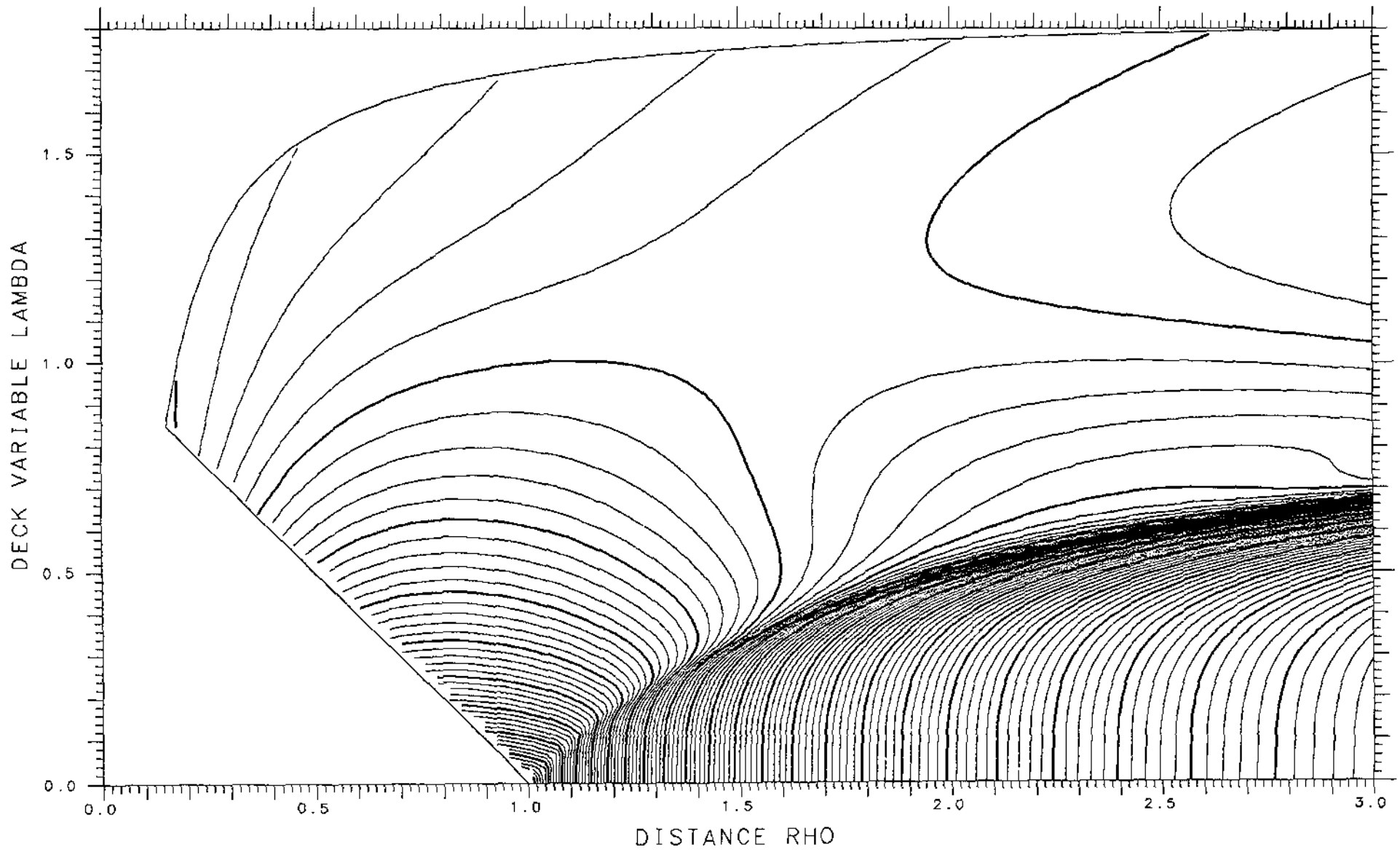

X= .675 ASYMMETRY DELTA= .400 FRACTIONAL= .9270

SPHERES -.01759 TANGENT .09168 LENGTH 9.966 ENERGY 568.61 SPACING .002 SADDLE .07412

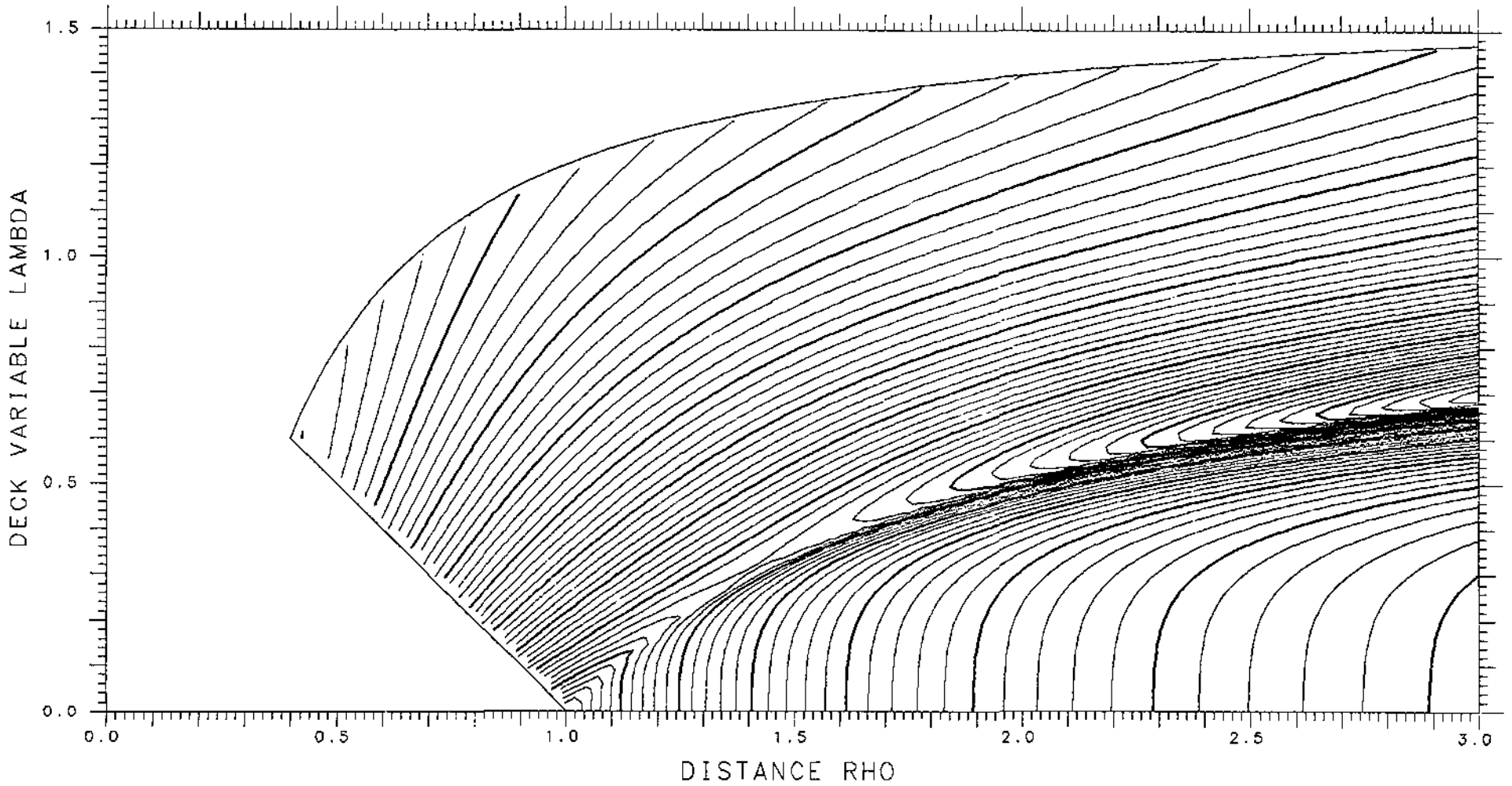

X= .800 ASYMMETRY DELTA= .125 FRACTIONAL= .6800

SPHERES -.27798 TANGENT .09317 LENGTH 11.976 ENERGY 641.16 SPACING .002 SADDLE .00852

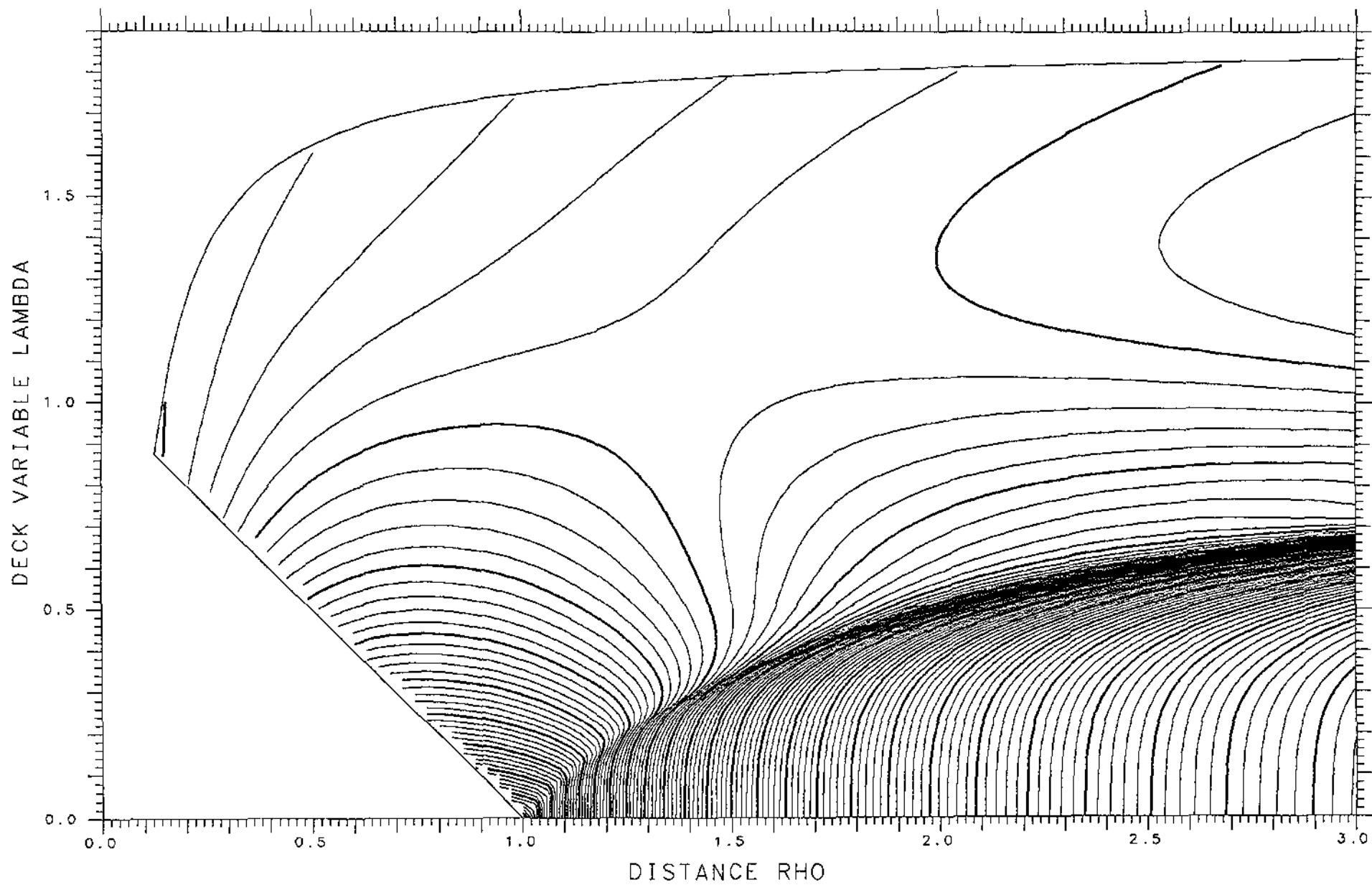

X= .675 ASYMMETRY DELTA= .425 FRACTIONAL= .9384

SPHERES -.00833 TANGENT .08640 LENGTH 9.831 ENERGY 568.61 SPACING .002 SADDLE .07227

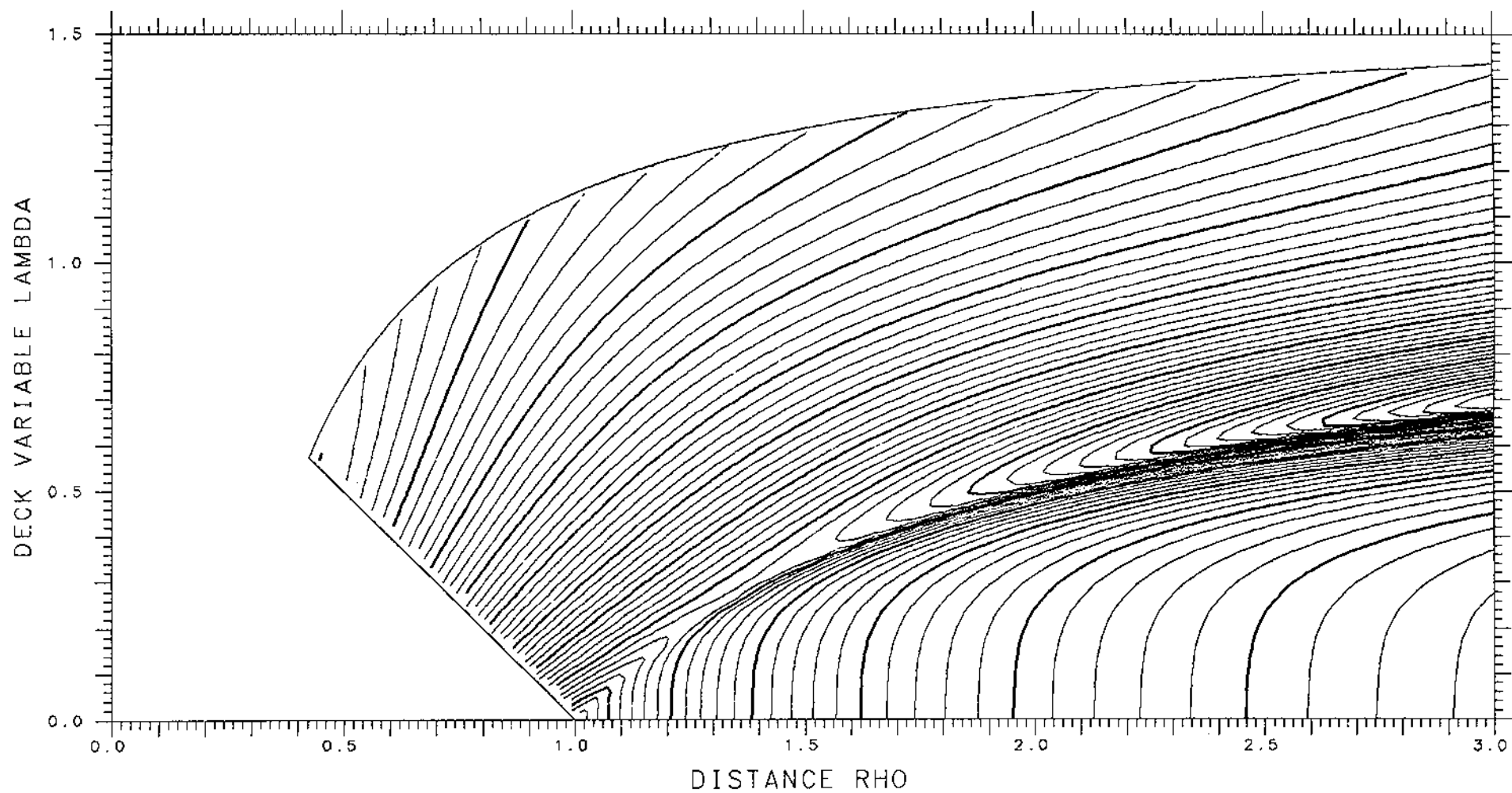

X= .800 ASYMMETRY DELTA= .100 FRACTIONAL= .6461

SPHERES -.29640 TANGENT .09151 LENGTH 12.041 ENERGY 641.16 SPACING .002 SADDLE .00791

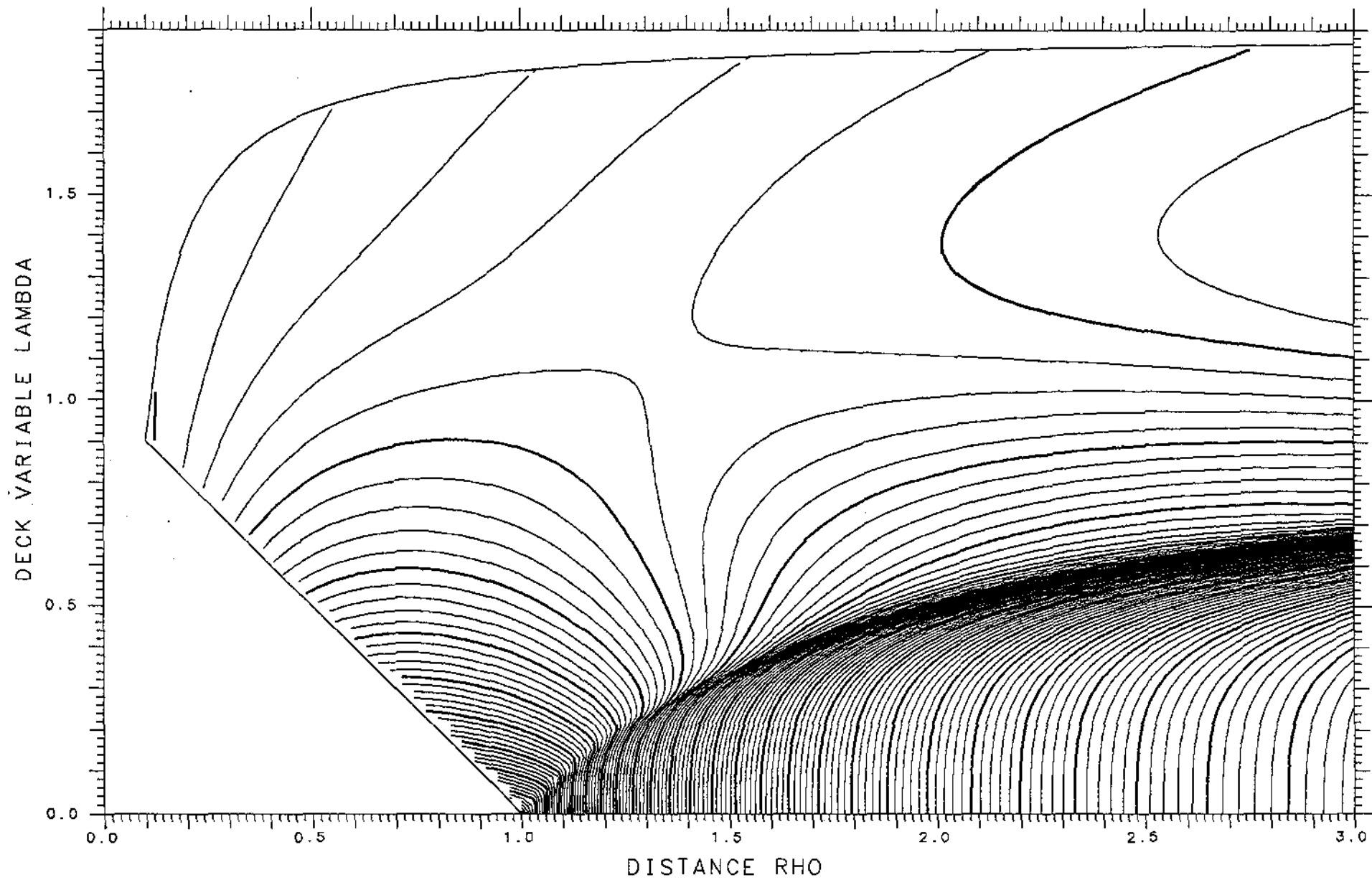

X= .675 ASYMMETRY DELTA= .450 FRACTIONAL= .9483

SPHERES -.00065 TANGENT .08083 LENGTH 9.695 ENERGY 568.61 SPACING .002

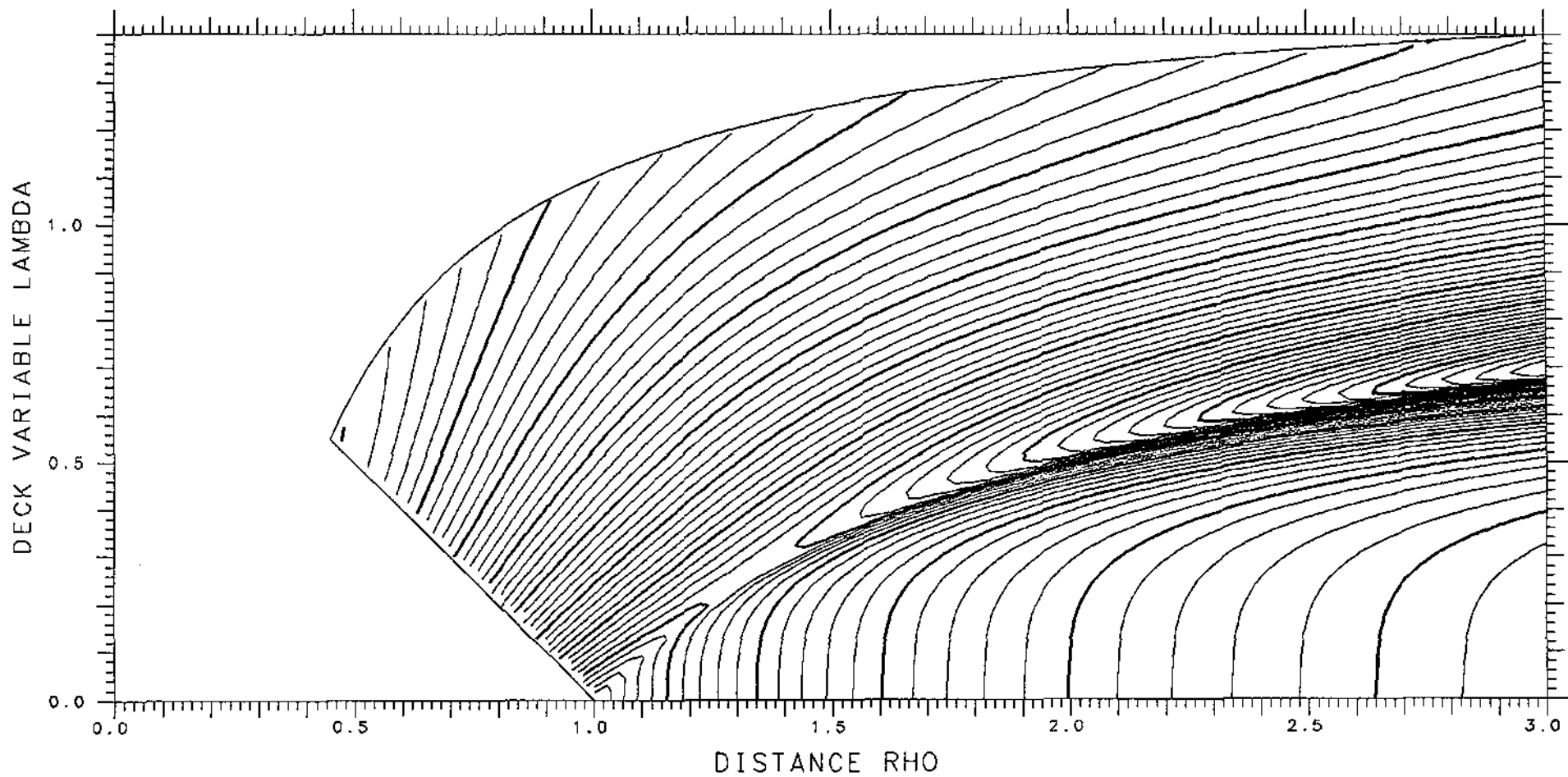

X= .800 ASYMMETRY DELTA= .075 _FRACTIONAL= .6108

SPHERES -.31154 TANGENT .09003 LENGTH 12.093 ENERGY 641.16 SPACING .002 SADDLE .00741

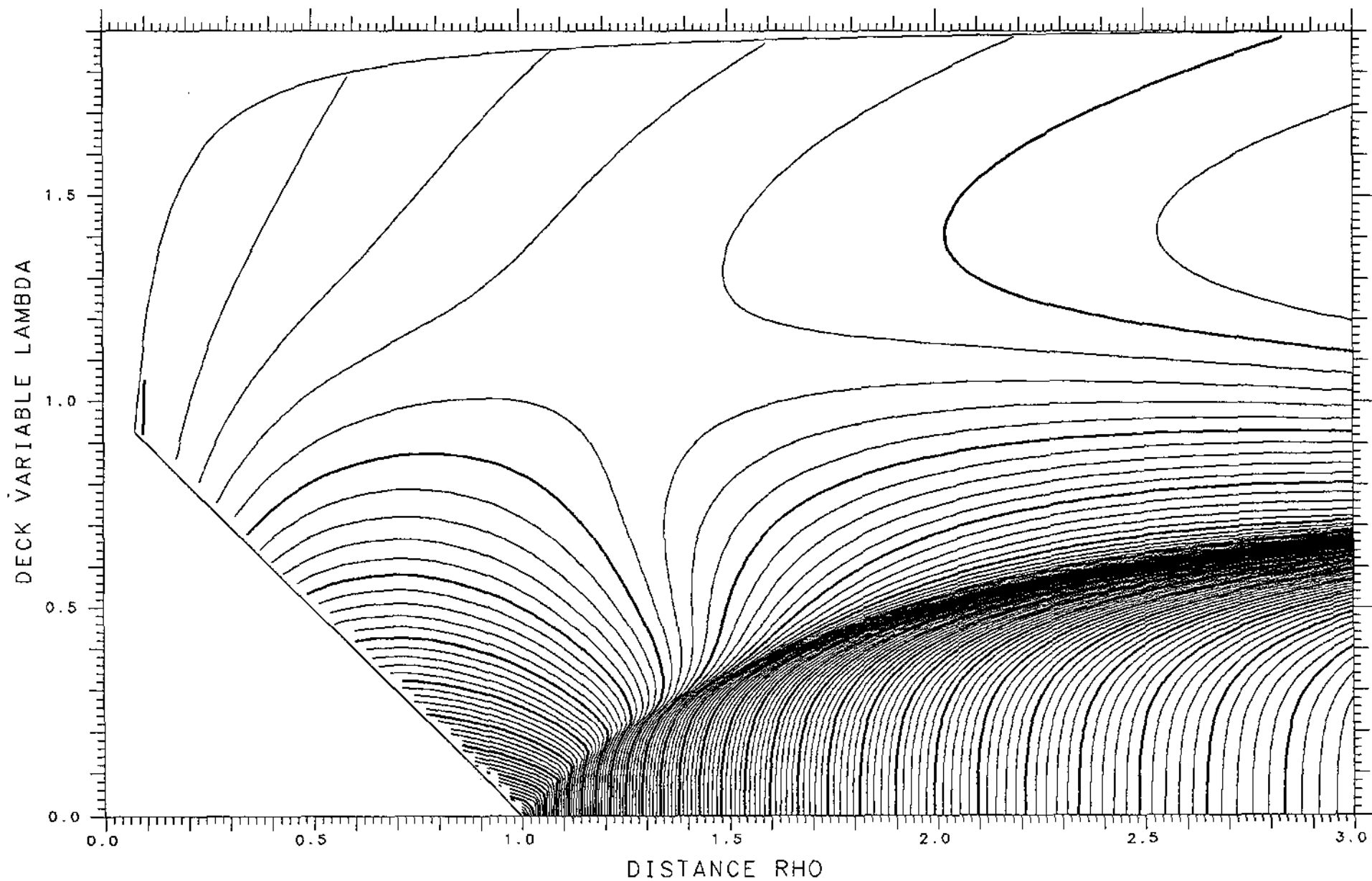

X= .675 ASYMMETRY DELTA= .475 FRACTIONAL= .9569

SPHERES .00553 TANGENT .07505 LENGTH 9.559 ENERGY 568.61 SPACING .002

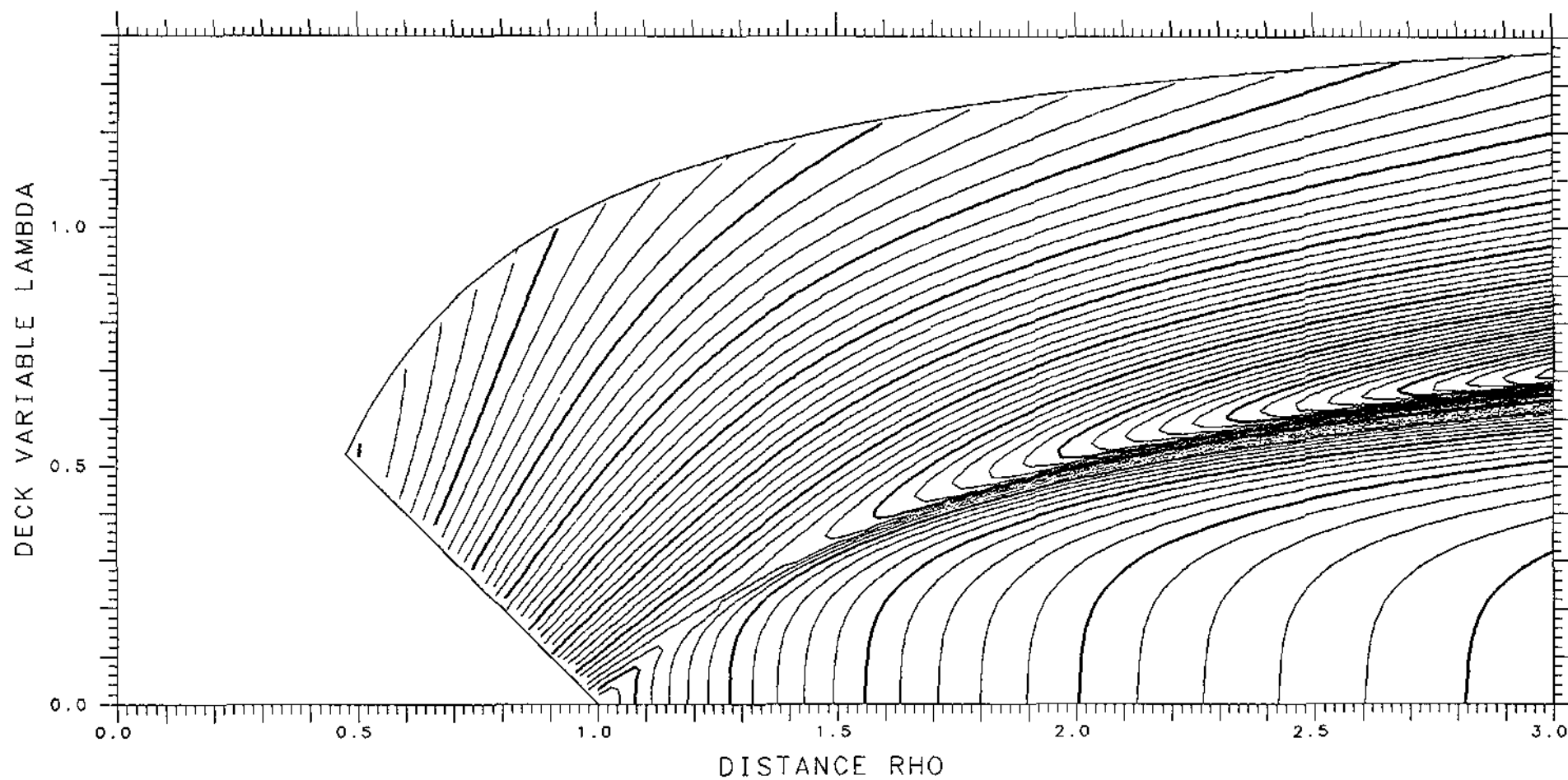

X = .800

ASYMMETRY DELTA = .050

FRACTIONAL = .5745

SPHERES = .32283

TANGENT .08885

LENGTH 12.130

ENERGY 641.16

SPACING .002

SADDLE .00704

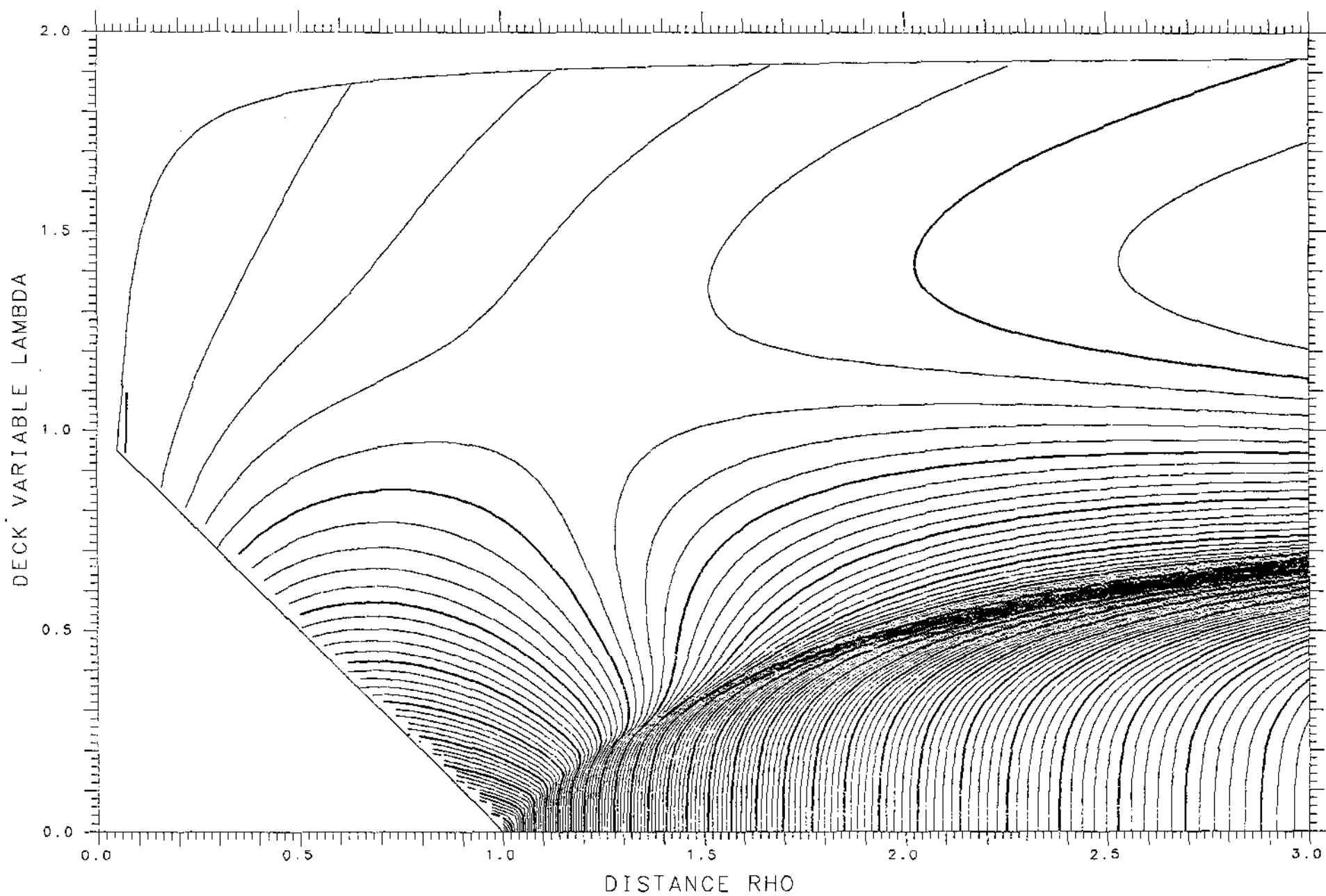

X= .675 ASYMMETRY DELTA= .500 FRACTIONAL= .9643

SPHERES .01033 TANGENT .06915 LENGTH 9.424 ENERGY 568.61 SPACING .002

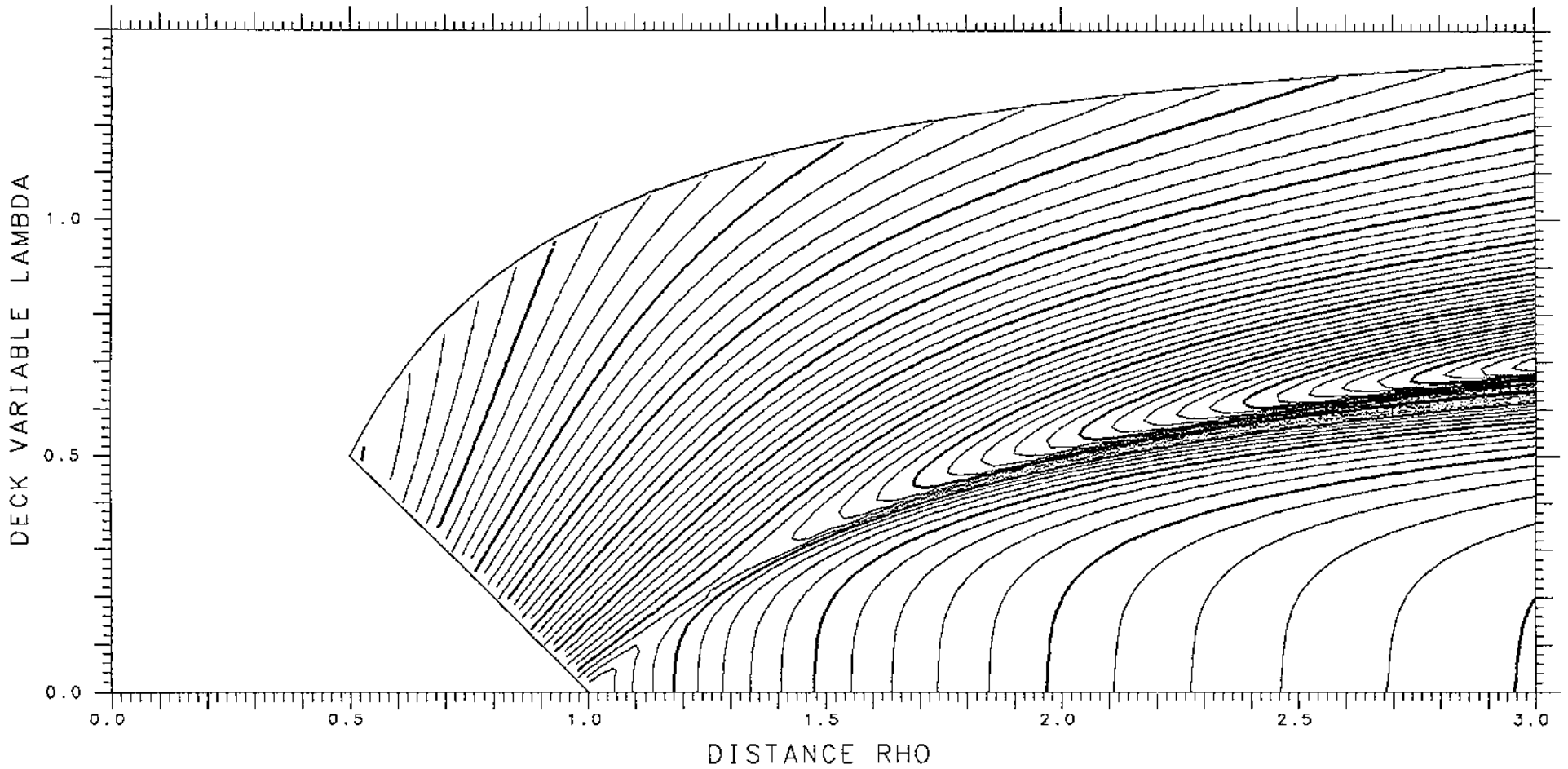

X= .800 ASYMMETRY DELTA= .025 FRACTIONAL= .5374

SPHERES -.32979 TANGENT .08809 LENGTH 12.153 ENERGY 641.16 SPACING .002 SADDLE .00682

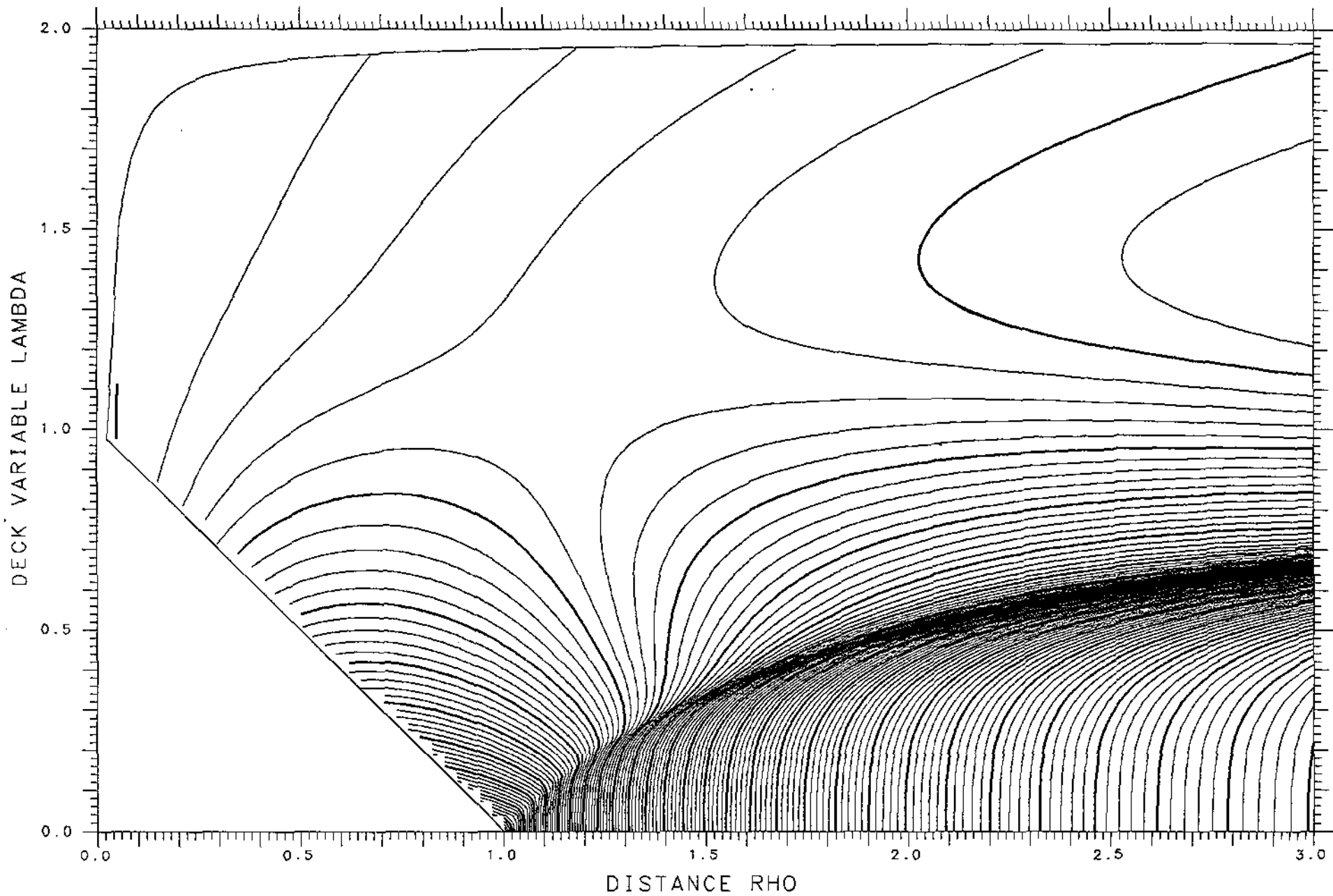

X= .675 ASYMMETRY DELTA= .525 FRACTIONAL= .9707

SPHERES .01388 TANGENT .06321 LENGTH 9.290 ENERGY 568.61 SPACING .002

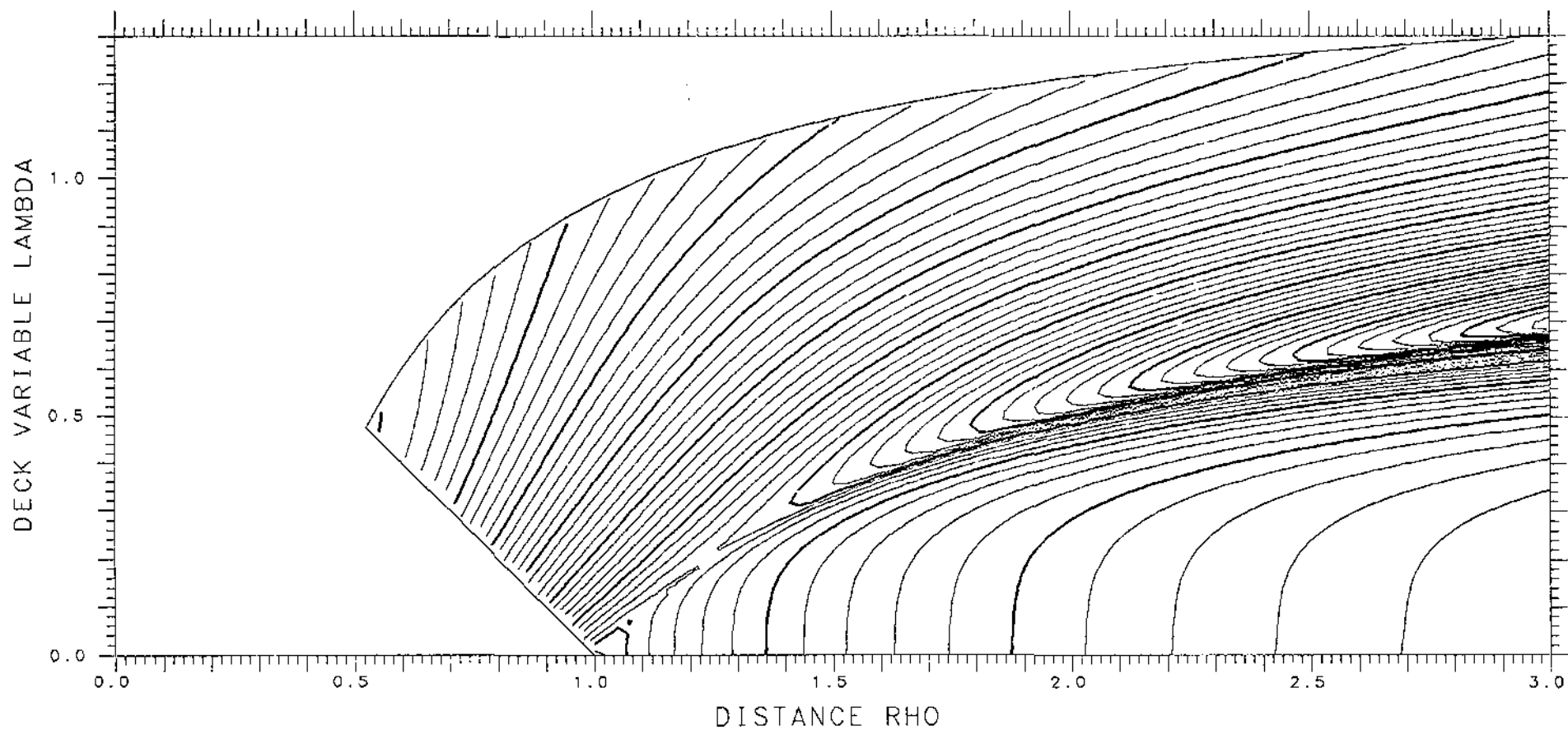

X= .800

ASYMMETRY DELTA=0.

FRACTIONAL= .5000

SPHERES -.33214

TANGENT .08783

LENGTH 12.160

ENERGY 641.16

SPACING .002

SADDLE .00674

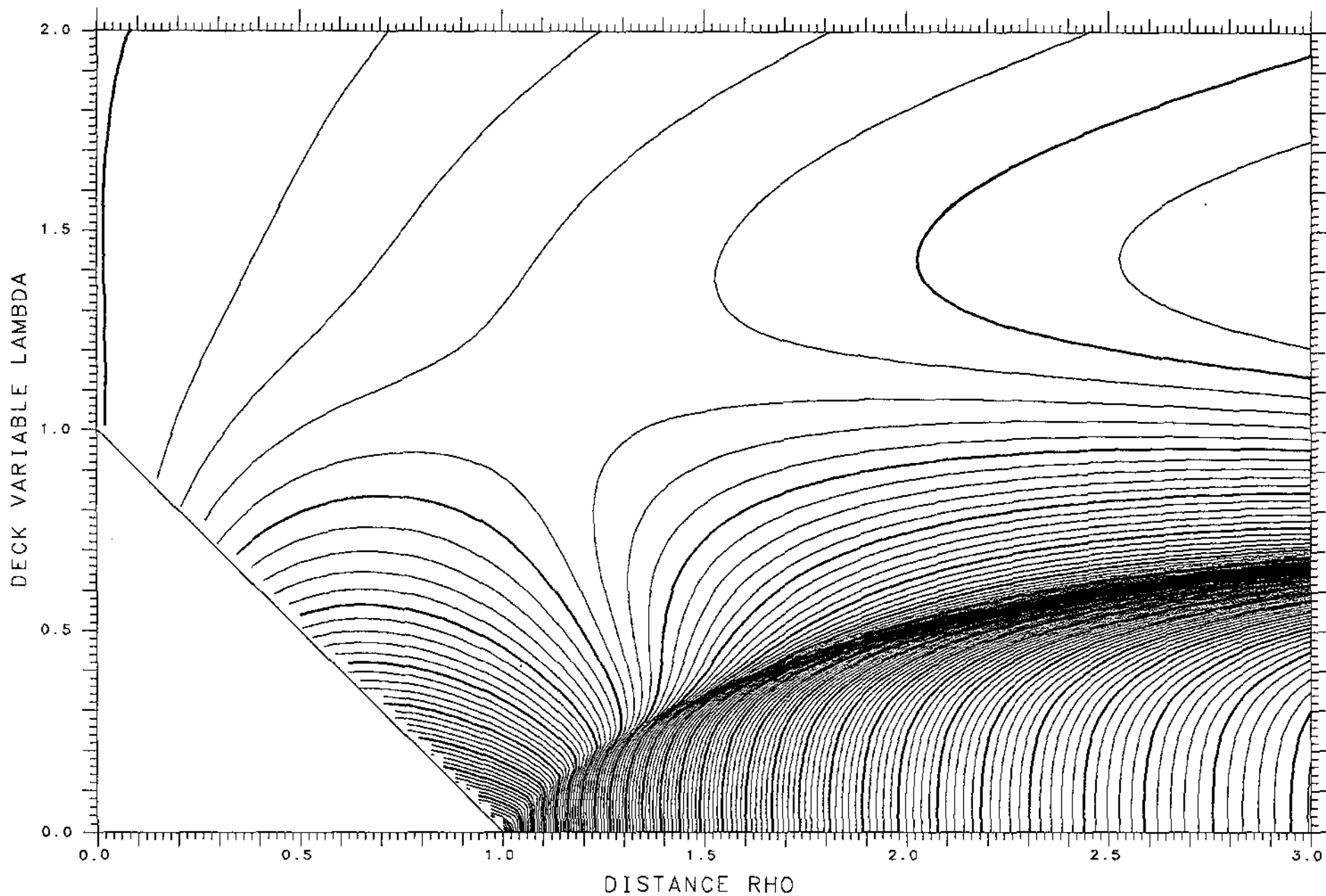

X= .675 ASYMMETRY DELTA= .550 FRACTIONAL= .9761

SPHERES .01631 TANGENT .05730 LENGTH 9.158 ENERGY 568.61 SPACING .002

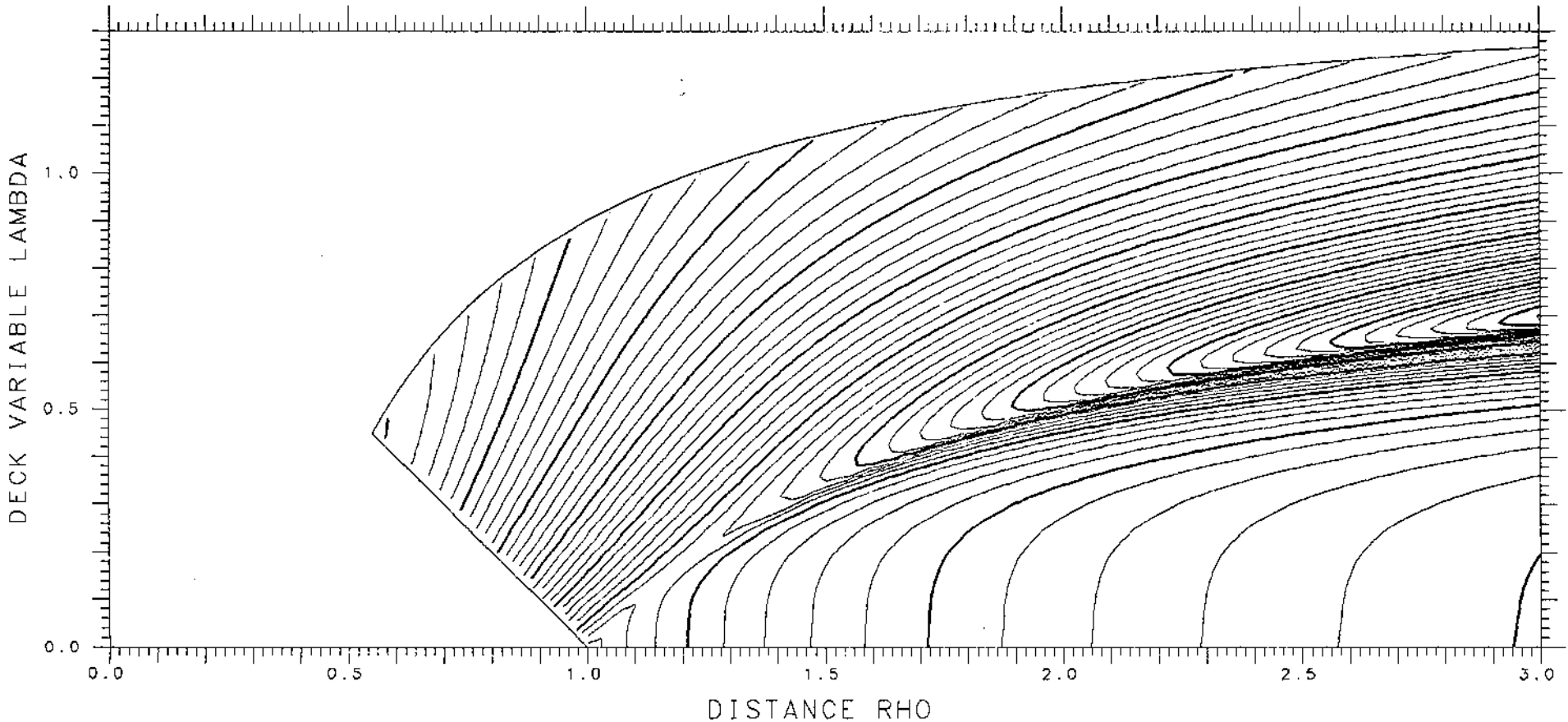

X= .775 ASYMMETRY DELTA= .600 FRACTIONAL= .9846
SPHERES .01351 TANGENT .04498 LENGTH 9.406 ENERGY 627.05 SPACING .002

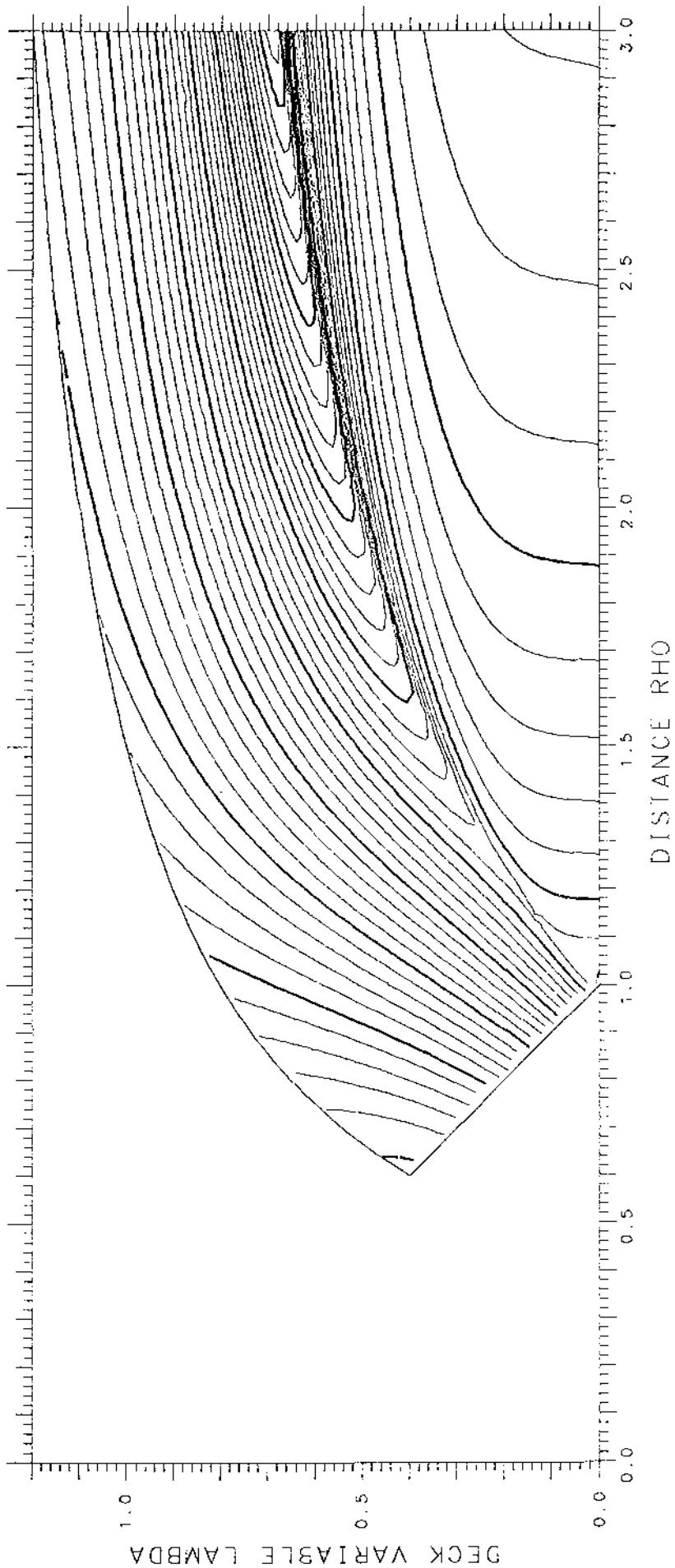

X= .675 ASYMMETRY DELTA= .575 FRACTIONAL= .9807

SPHERES .01778 TANGENT .05148 LENGTH 9.026 ENERGY 568.61 SPACING .002

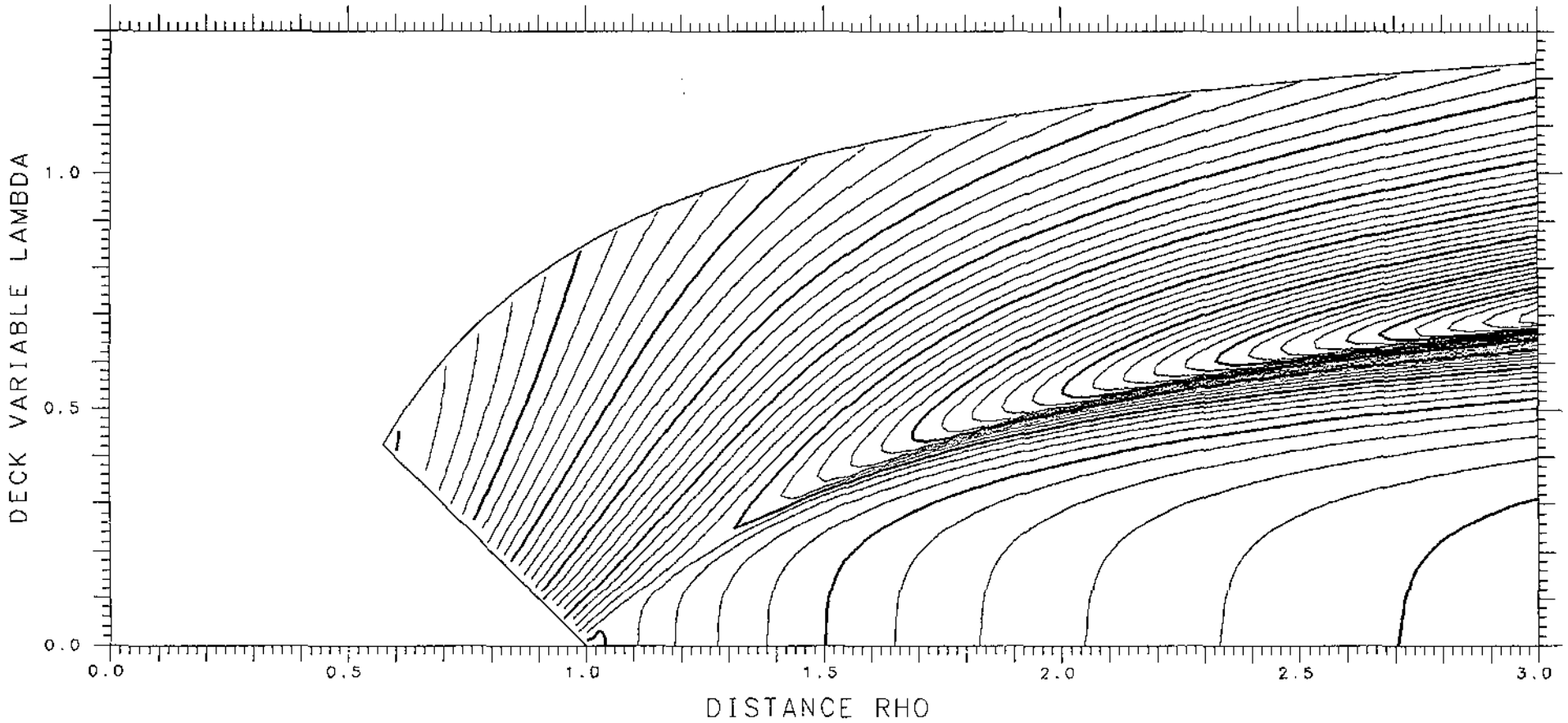

X = .775
SPHERES .01:67 TANGENT .05037 ASYMMETRY DELTA = .575 FRACTIONAL = .9807
LENGTH 9.542 ENERGY 627.06 SPACING .002

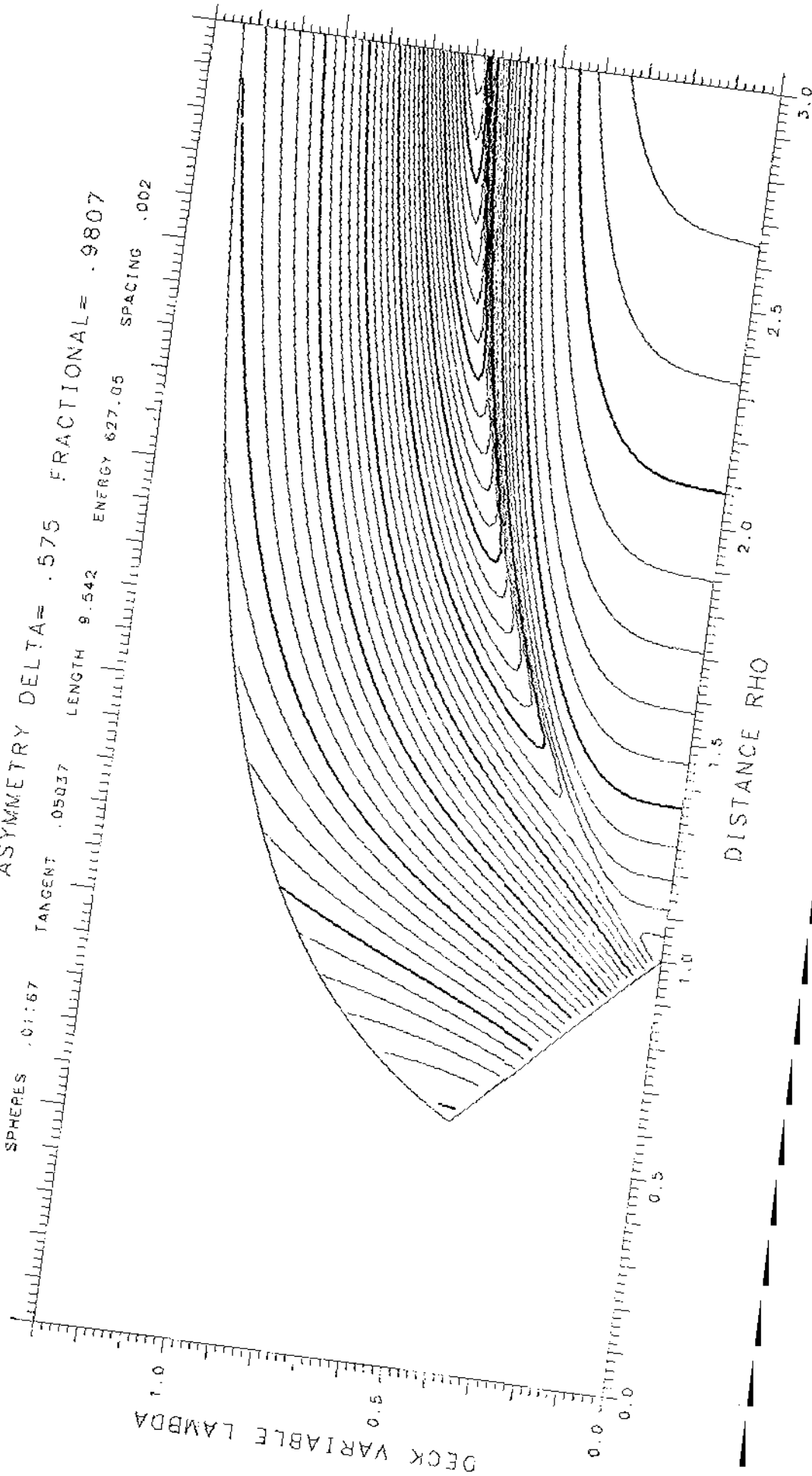

X= .700 ASYMMETRY DELTA=0. FRACTIONAL= .5000

SPHERES -.25813 TANGENT .10934 LENGTH 11.525 ENERGY 583.53 SPACING .002 SADDLE .02449

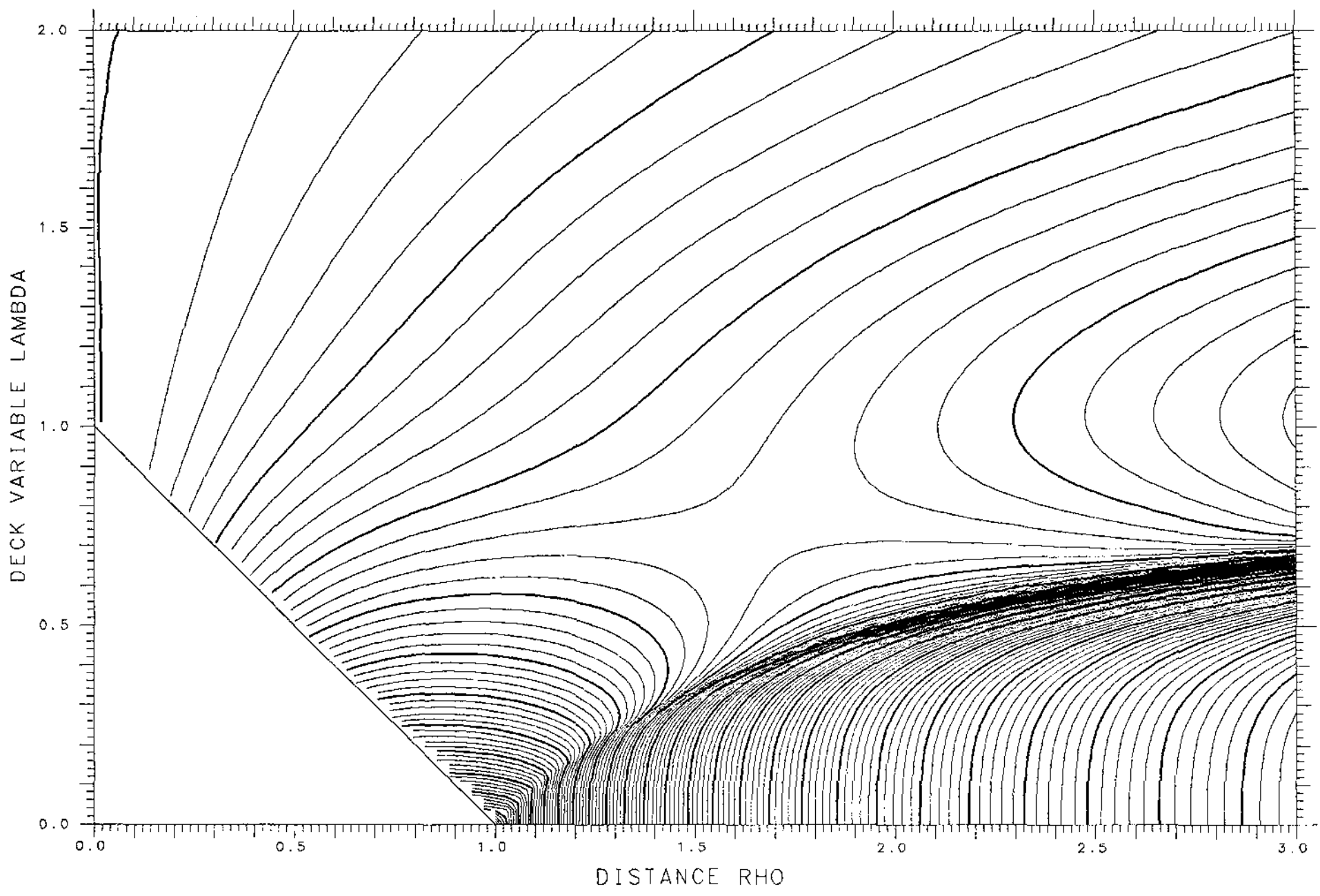

X= .775 ASYMMETRY DELTA= .550 FRACTIONAL= .9761

SPHERES .00881 TANGENT .05587 LENGTH 9.681 ENERGY 627.05 SPACING .002

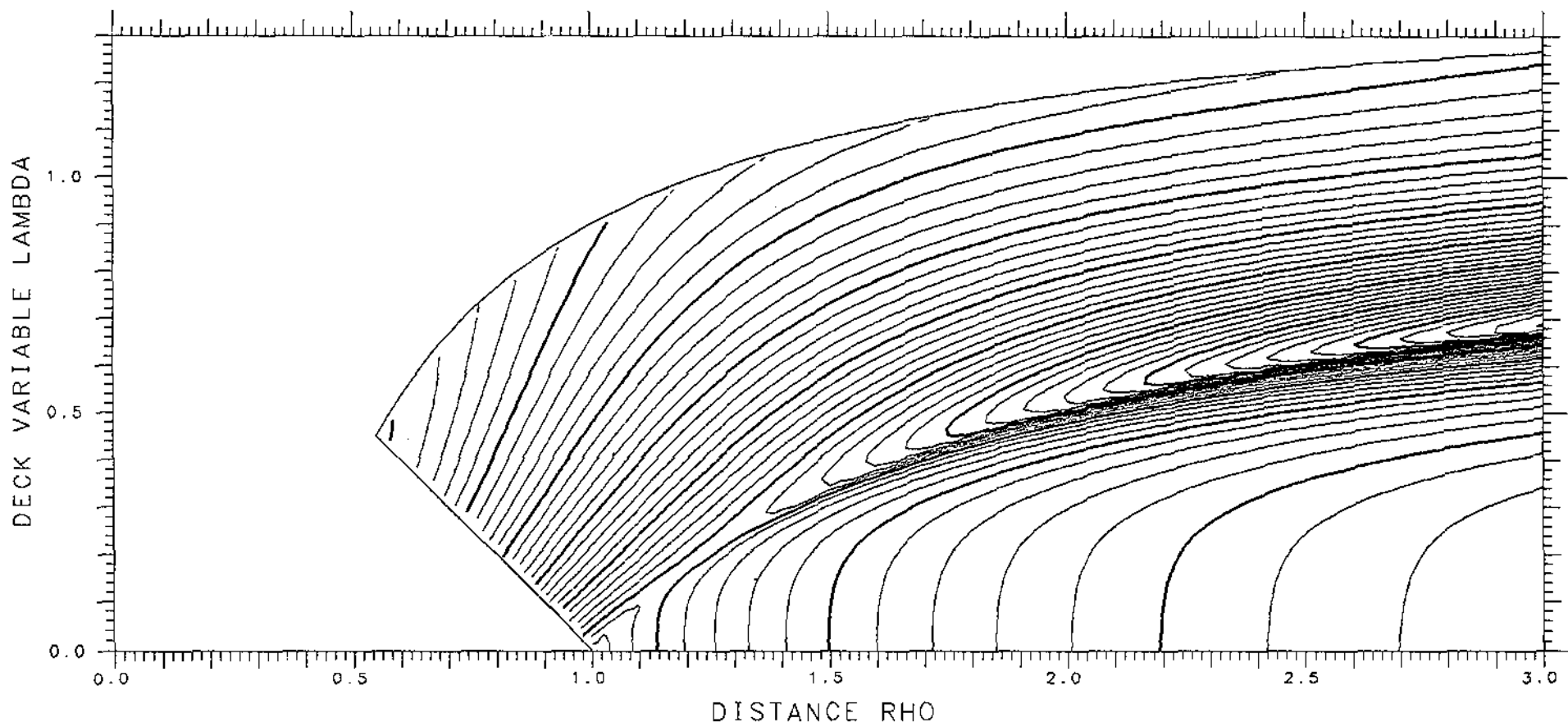

X= .700 ASYMMETRY DELTA= .025 FRACTIONAL= .5374

SPHERES -.25617 TANGENT .10947 LENGTH 11.518 ENERGY 583.53 SPACING .002 SADDLE .02475

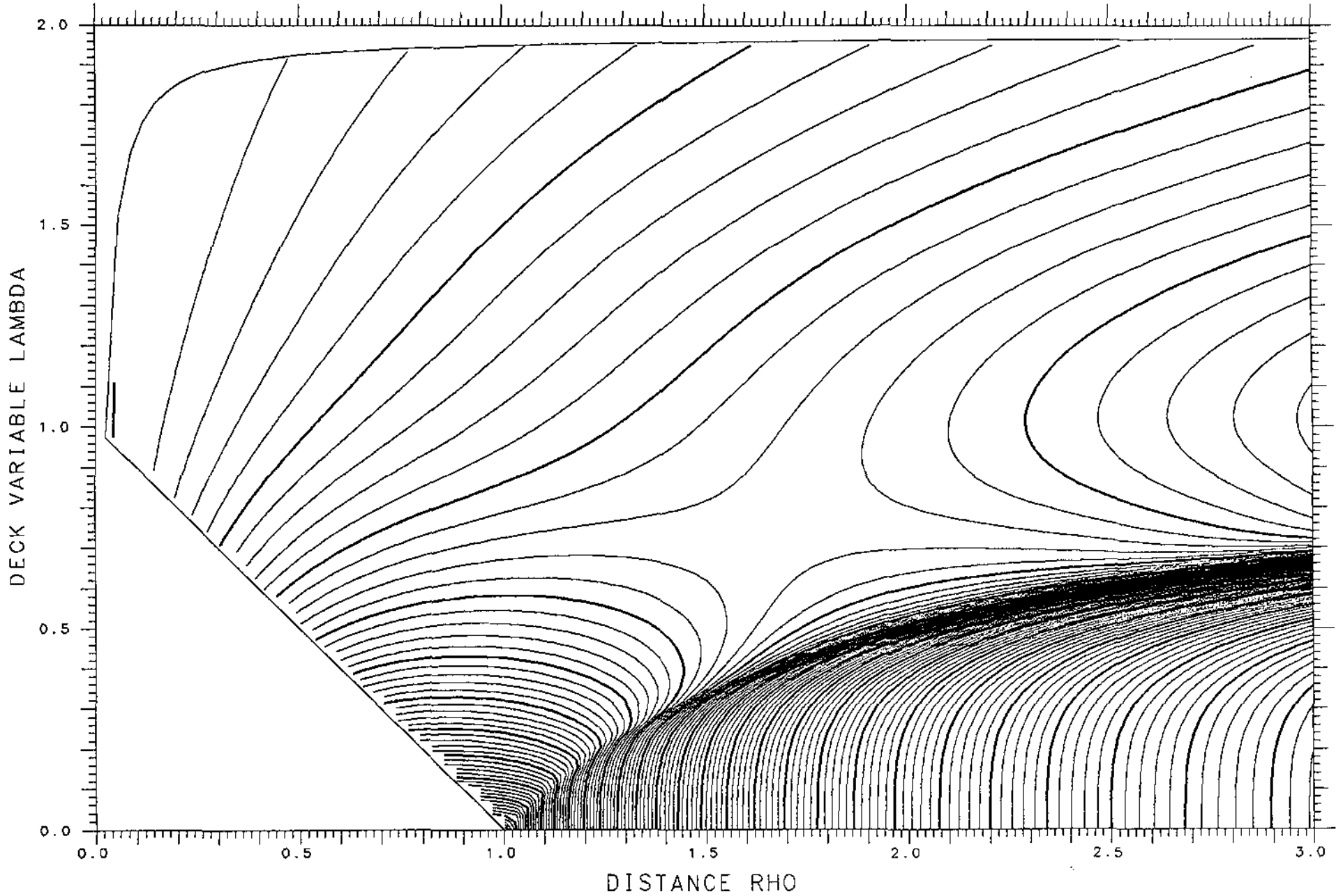

X= .775 ASYMMETRY DELTA= .525 FRACTIONAL= .9707

SPHERES .00475 TANGENT .06139 LENGTH 9.821 ENERGY 627.05 SPACING .002

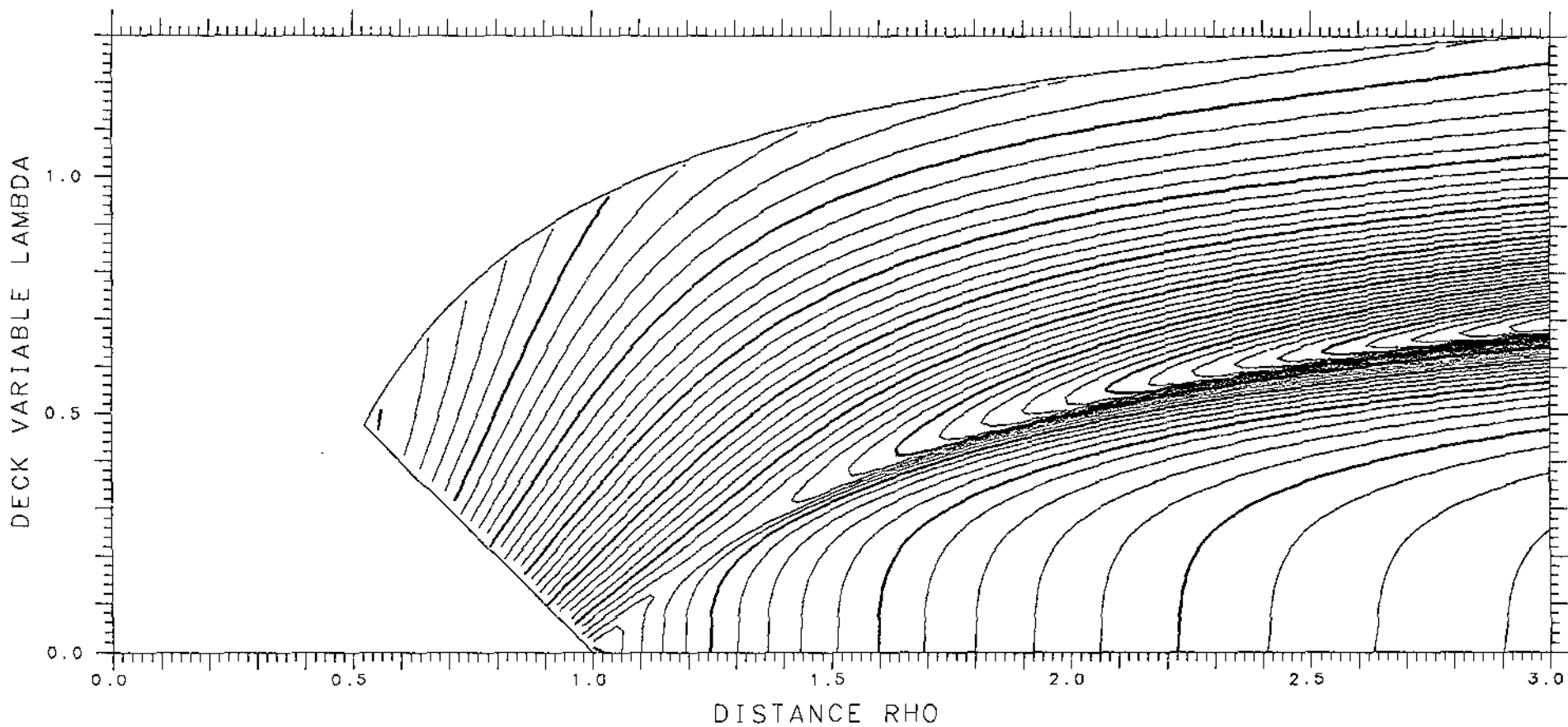

X= .700 ASYMMETRY DELTA= .050 FRACTIONAL= .5745

SPHERES -.25037 TANGENT .10984 LENGTH 11.496 ENERGY 583.53 SPACING .002 SADDLE .02554

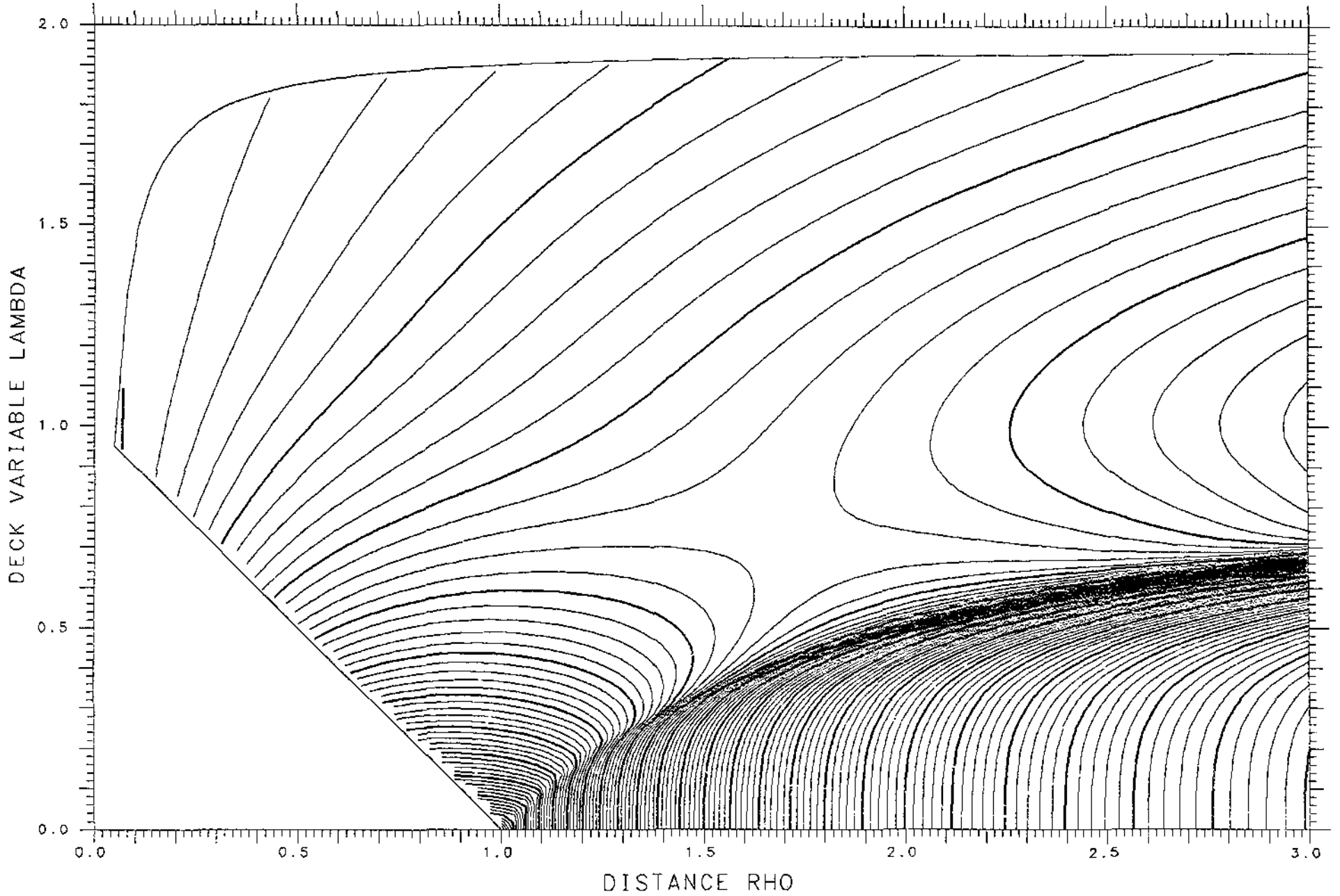

X= .775 ASYMMETRY DELTA= .500 FRACTIONAL= .9643

SPHERES -.00066 TANGENT .06688 LENGTH 9.963 ENERGY 627.05 SPACING .002

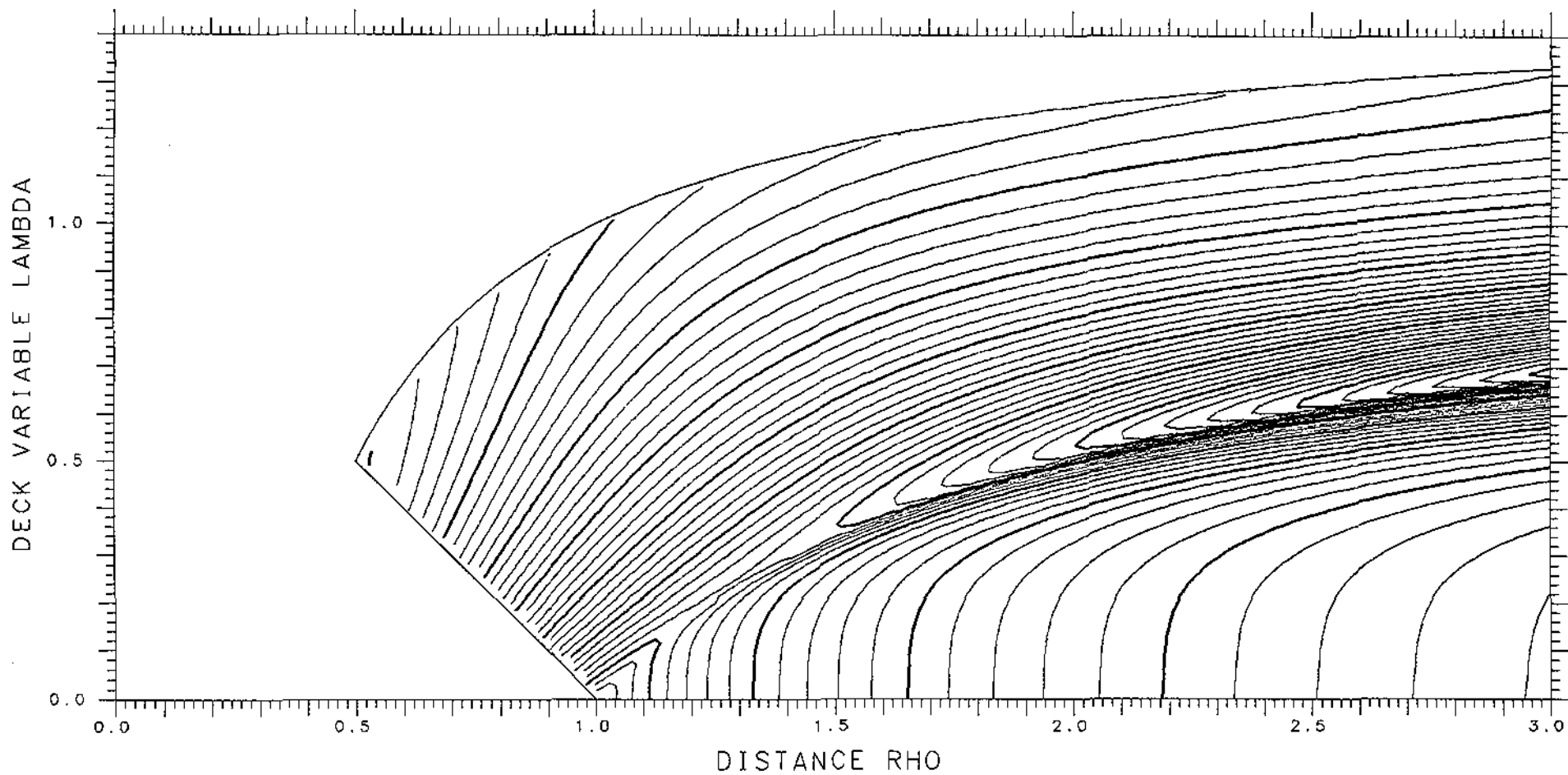

X= .700

ASYMMETRY DELTA= .075

FRACTIONAL= .6108

SPHERES -.24098

TANGENT .11039

LENGTH 11.461

ENERGY 583.53

SPACING .002

SADDLE .02699

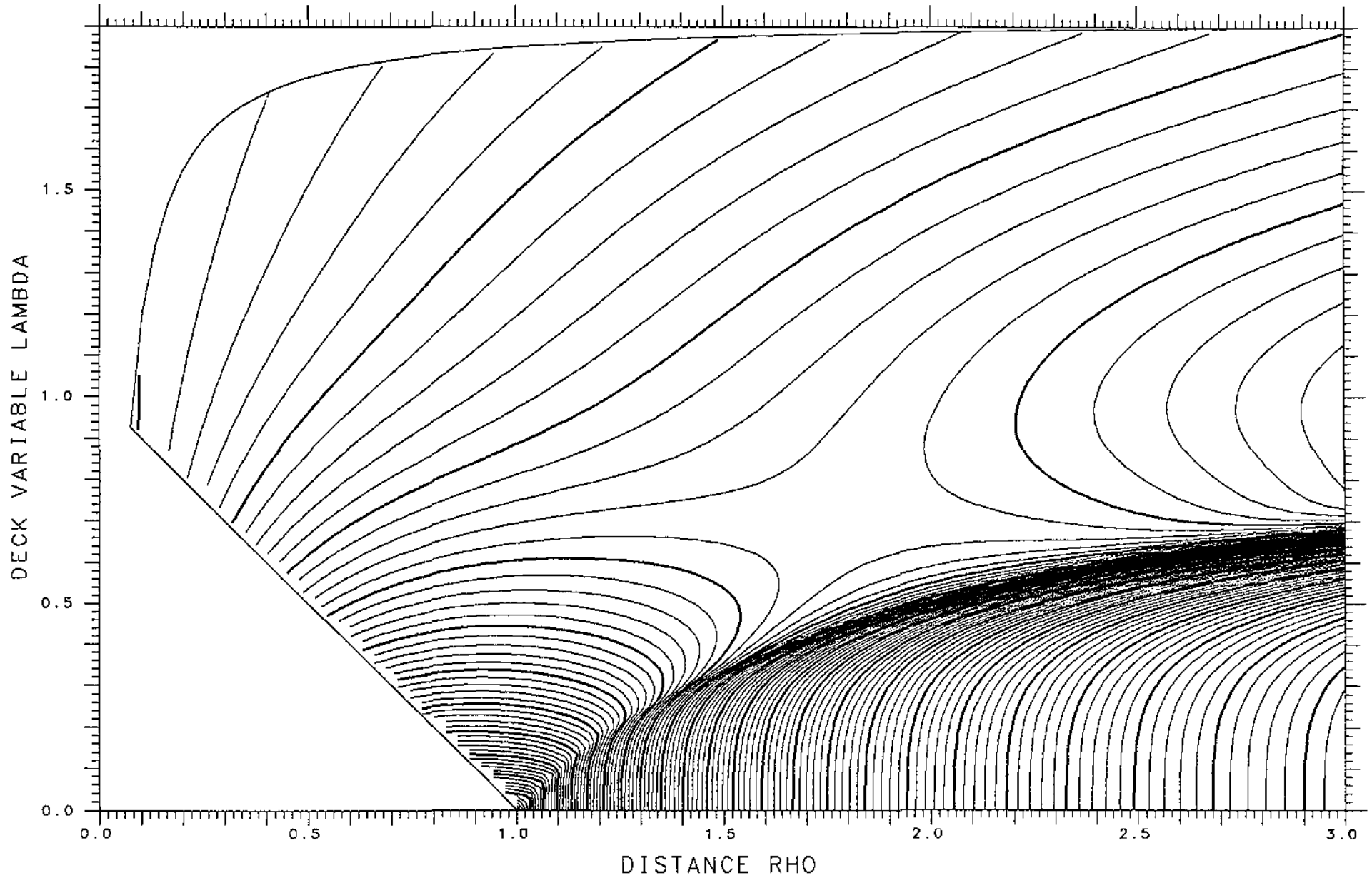

X= .775 ASYMMETRY DELTA= .475 FRACTIONAL= .9569

SPHERES -.00758 TANGENT .07224 LENGTH 10.106 ENERGY 627.05 SPACING .002

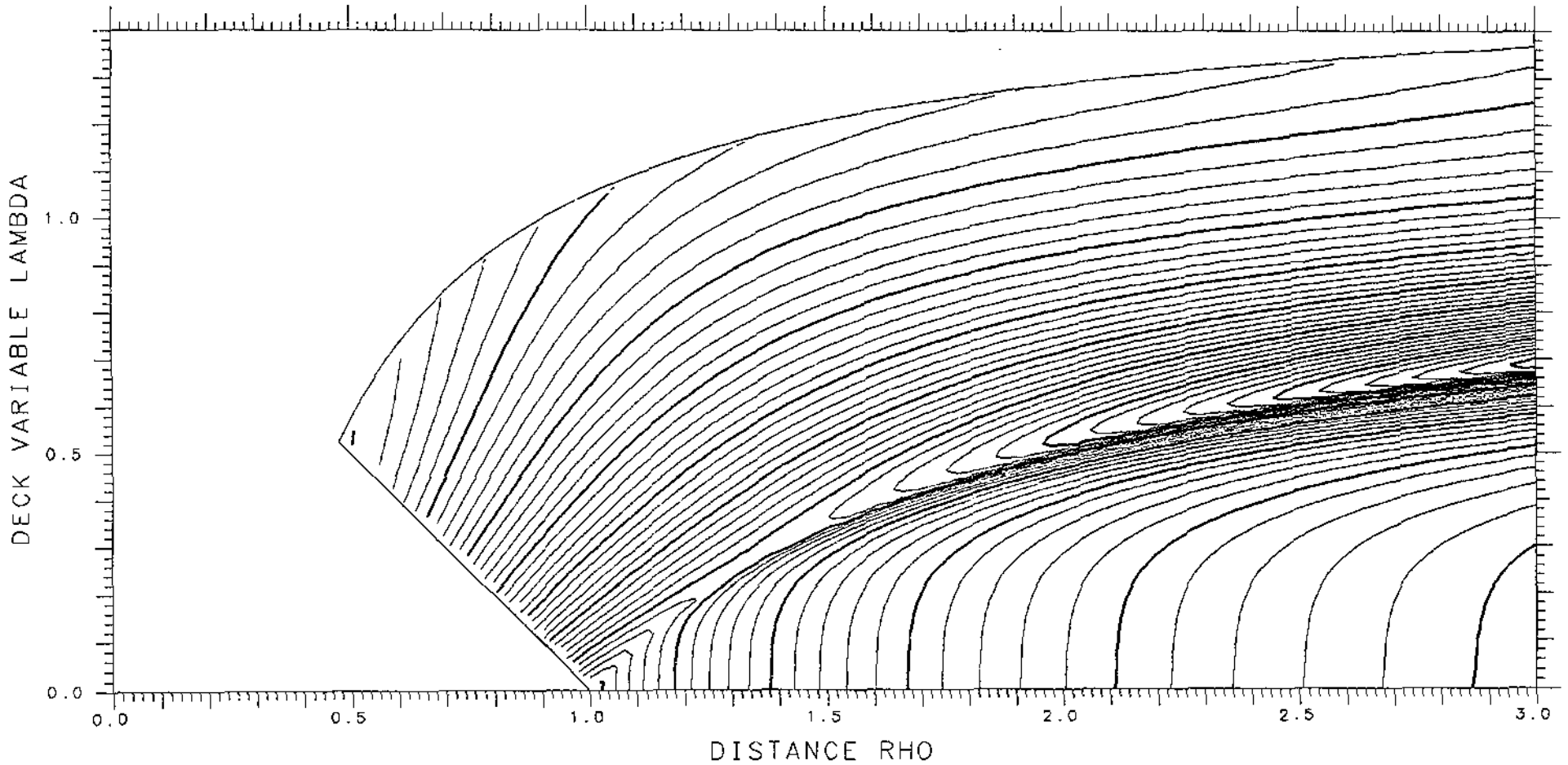

X= .700 ASYMMETRY DELTA= .100 FRACTIONAL= .6461

SPHERES -.22839 TANGENT .11104 LENGTH 11.412 ENERGY 583.53 SPACING .002 SADDLE .02933

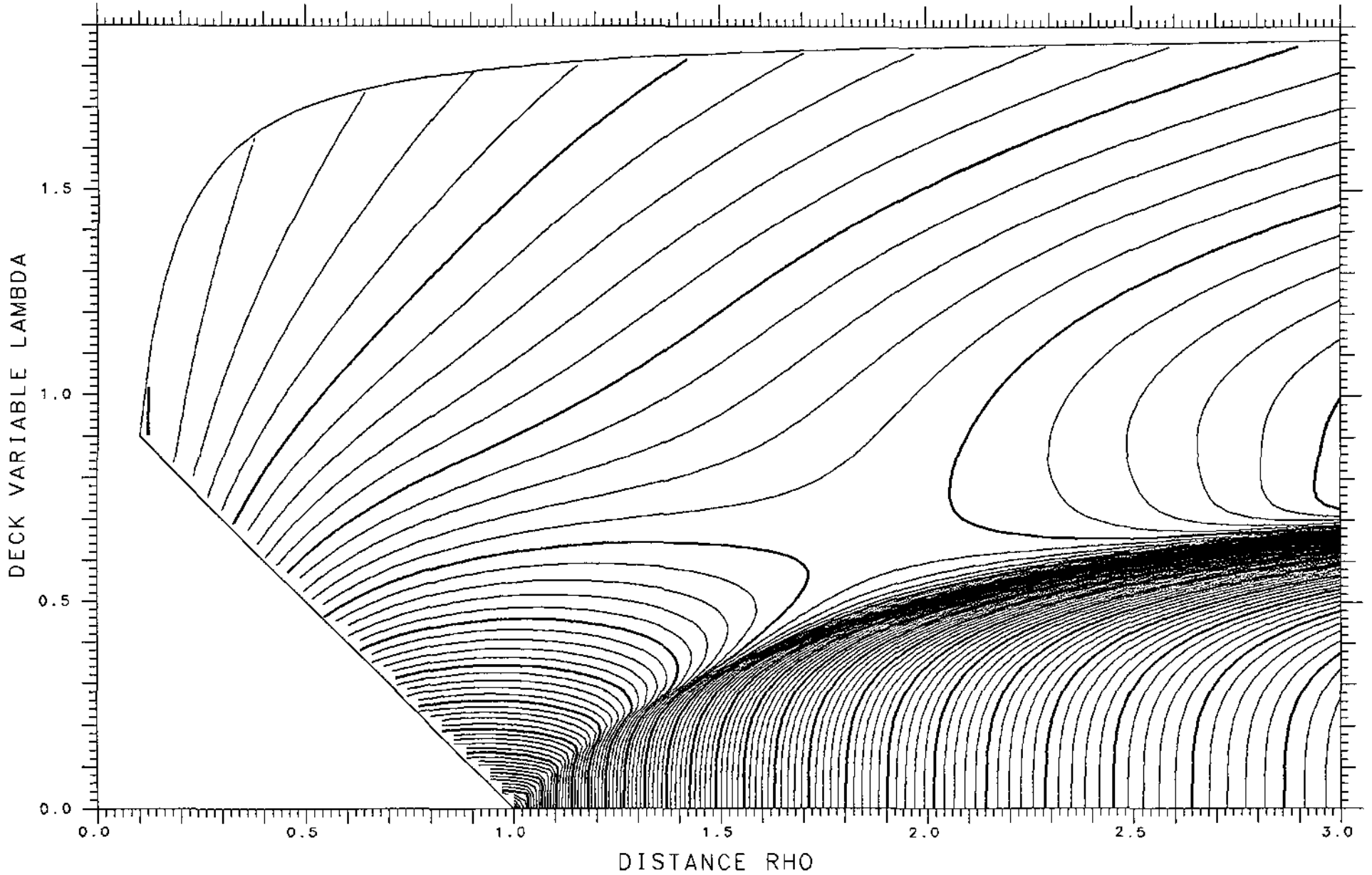

X= .775 ASYMMETRY DELTA= .450 FRACTIONAL= .9483

SPHERES -.01616 TANGENT .07739 LENGTH 10.249 ENERGY 627.05 SPACING .002 SADDLE .06304

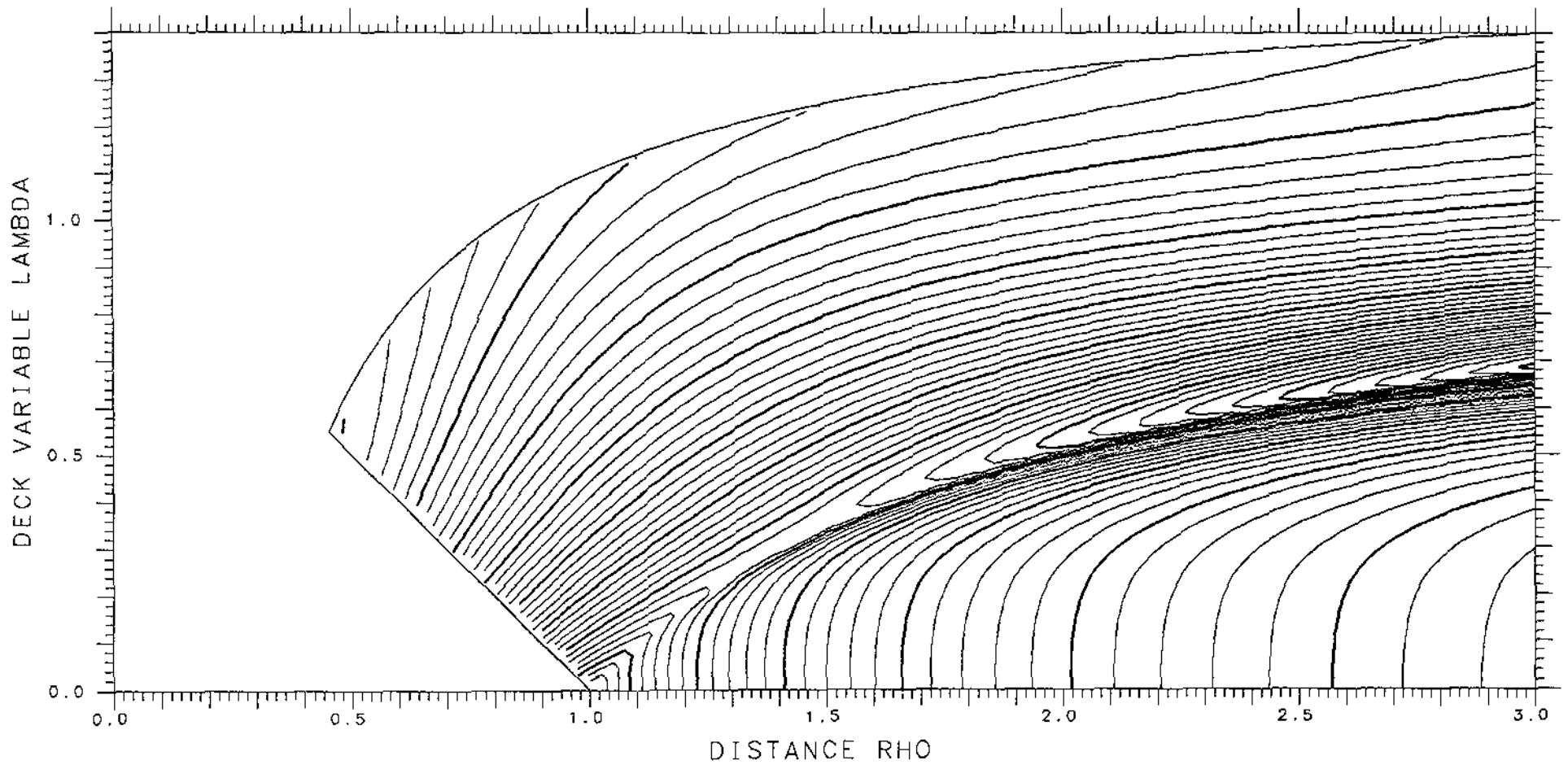

X= .700 ASYMMETRY DELTA= .125 FRACTIONAL= .6800

SPHERES -.21309 TANGENT .11166 LENGTH 11.350 ENERGY 583.63 SPACING .002 SADDLE .03284

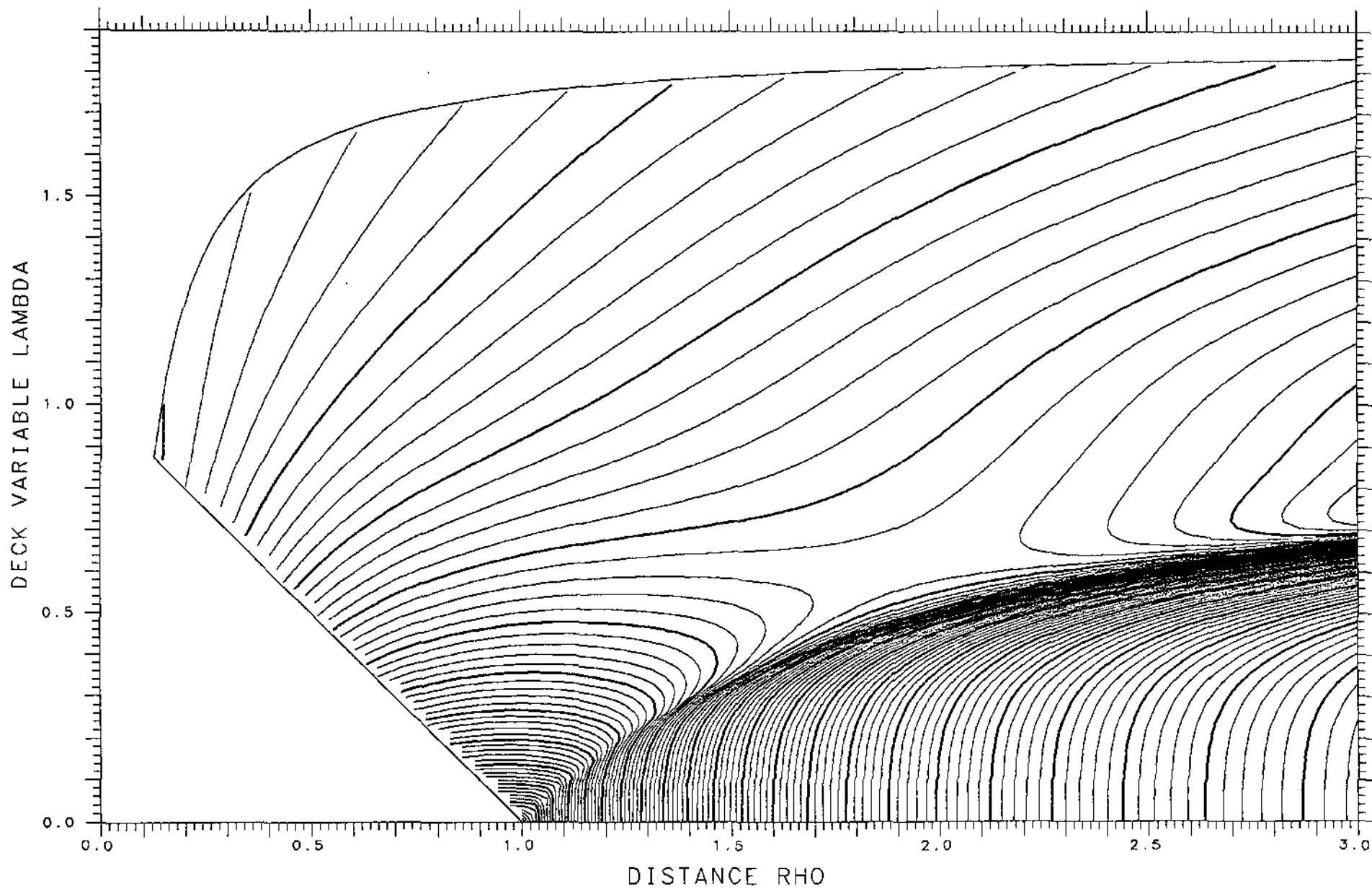

X= .775 ASYMMETRY DELTA= .425 FRACTIONAL= .9384

SPHERES -.02653 TANGENT .08223 LENGTH 10.393 ENERGY 627.05 SPACING .002 SADDLE .06412

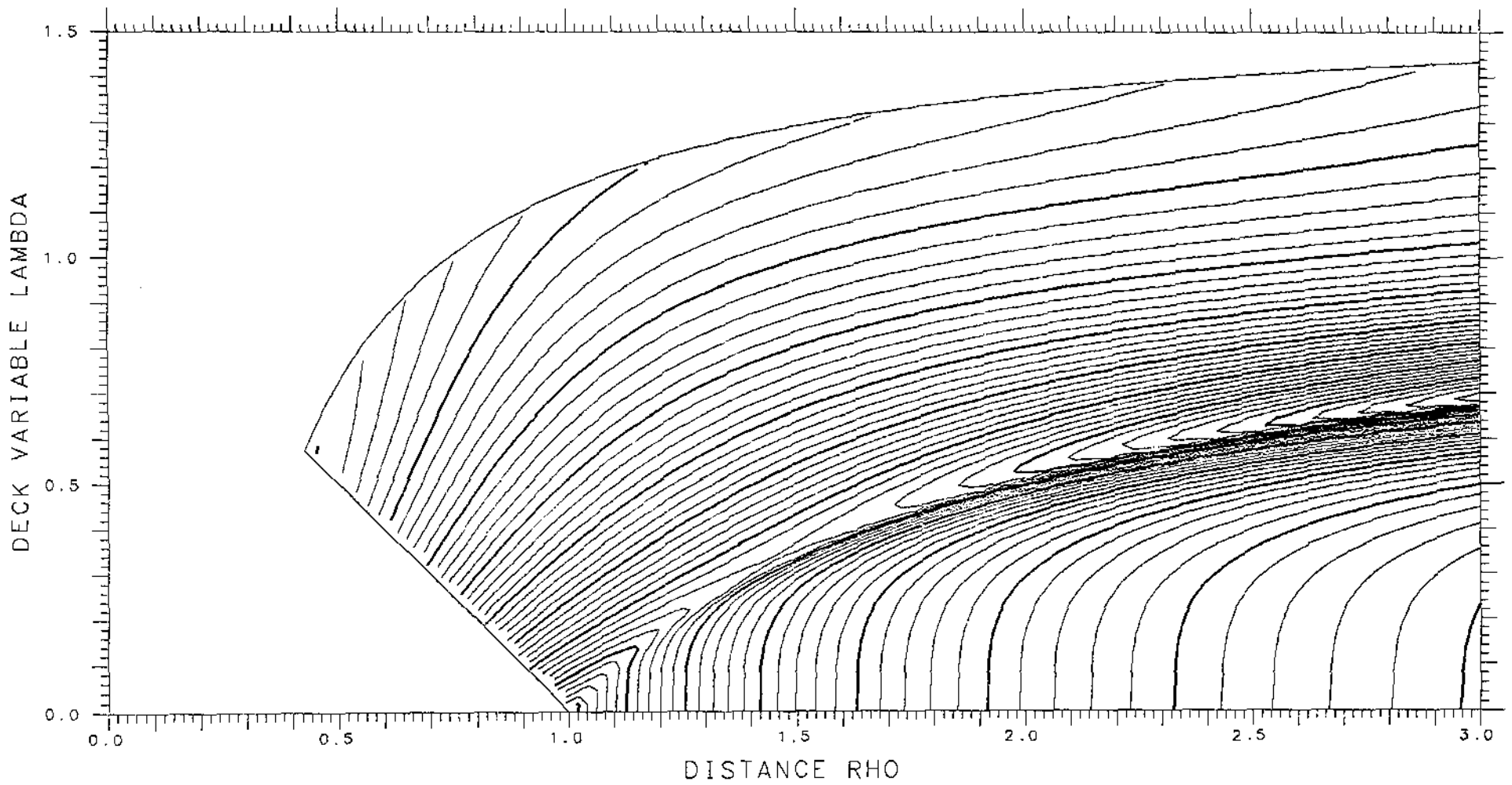

X= .700 ASYMMETRY DELTA= .150 FRACTIONAL= .7124

SPHERES -.19568 TANGENT .11214 LENGTH 11.277 ENERGY 583.53 SPACING .002 SADDLE .03740

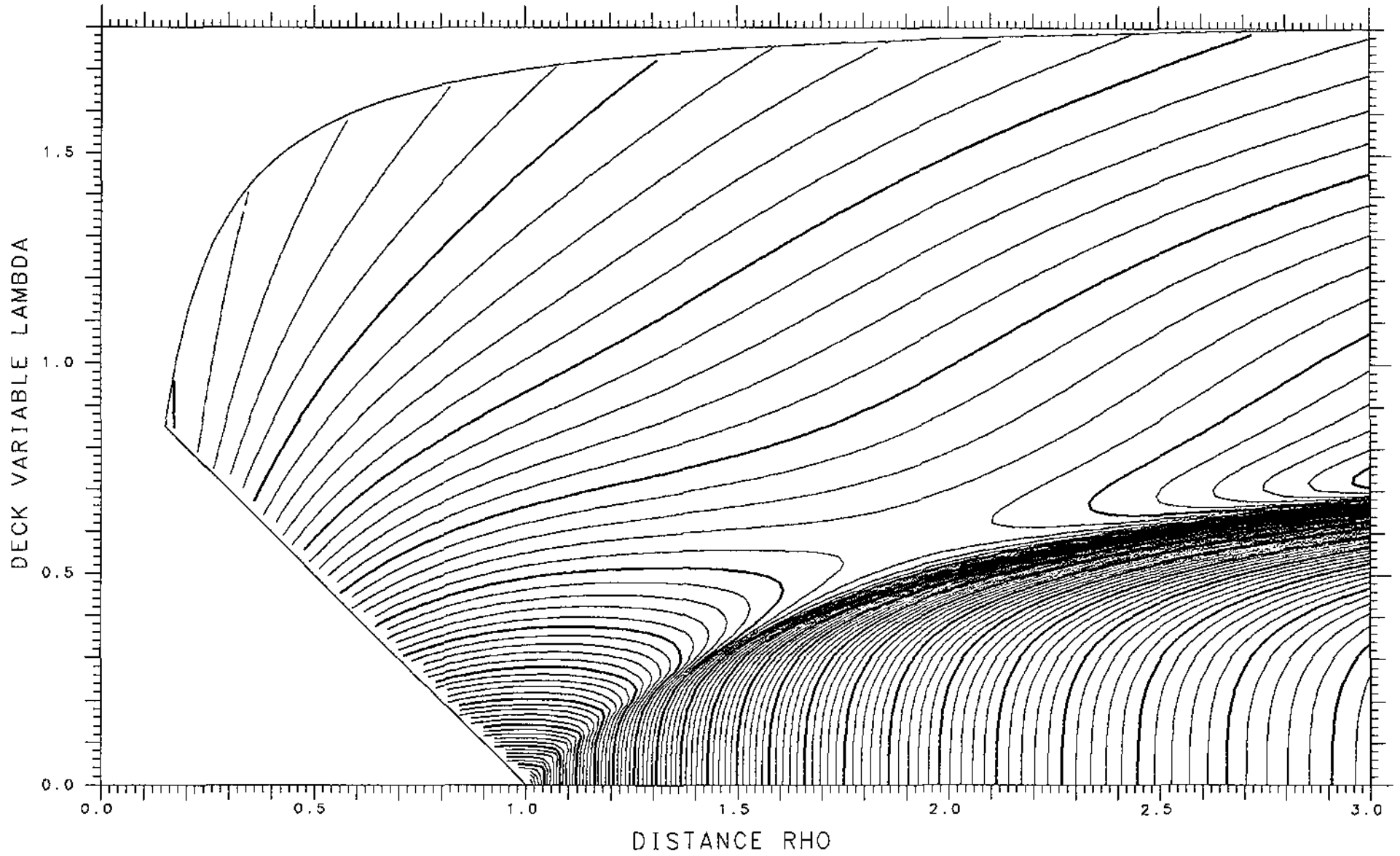

X= .775 ASYMMETRY DELTA= .400 FRACTIONAL= .9270

SPHERES -.03877 TANGENT .08669 LENGTH 10.536 ENERGY 627.05 SPACING .002 SADDLE .06415

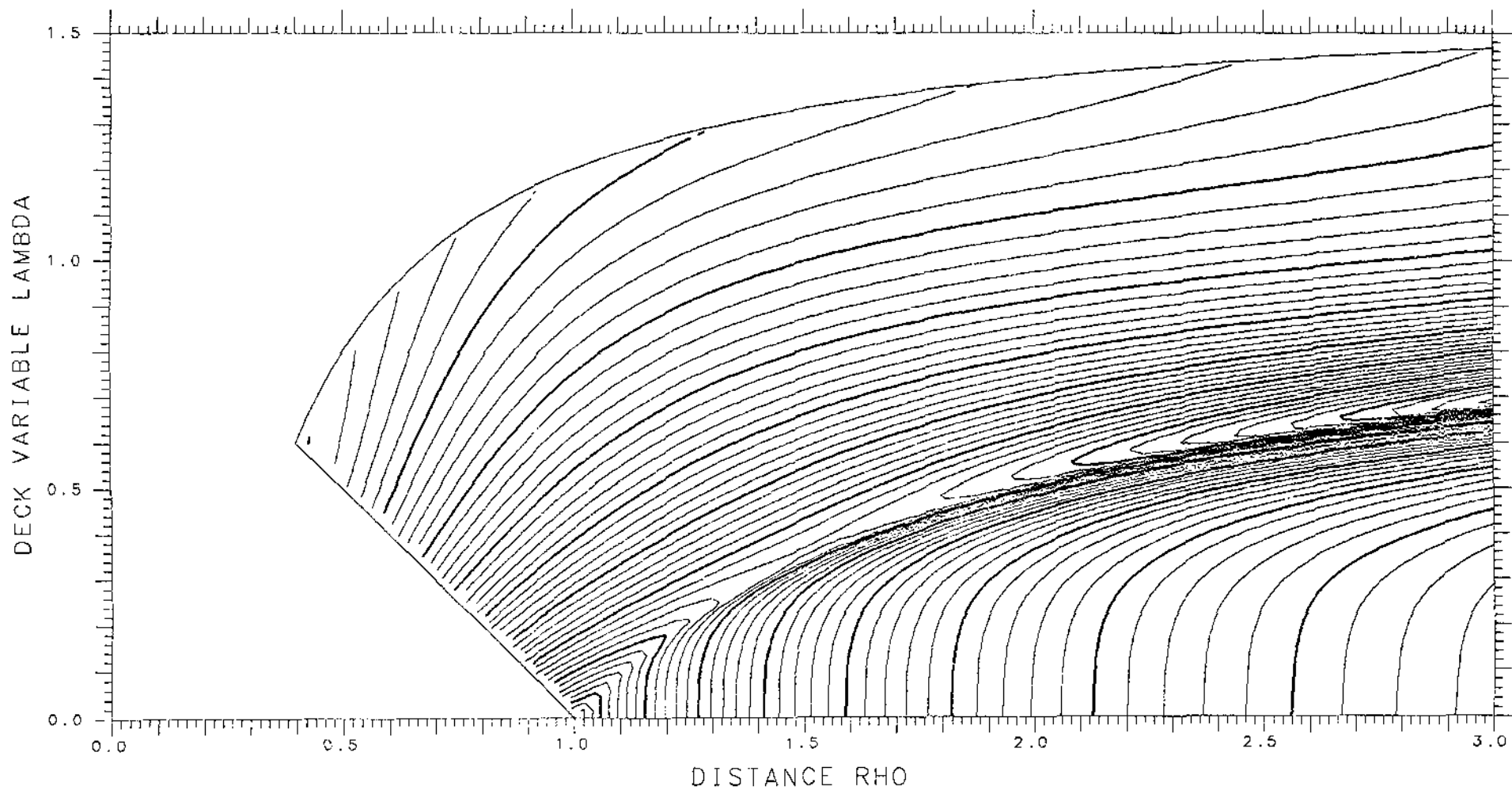

X= .700 ASYMMETRY DELTA= .175 FRACTIONAL= .7429

SPHERES -.17677 TANGENT .11235 LENGTH 11.192 ENERGY 583.53 SPACING .002 SADDLE .04267

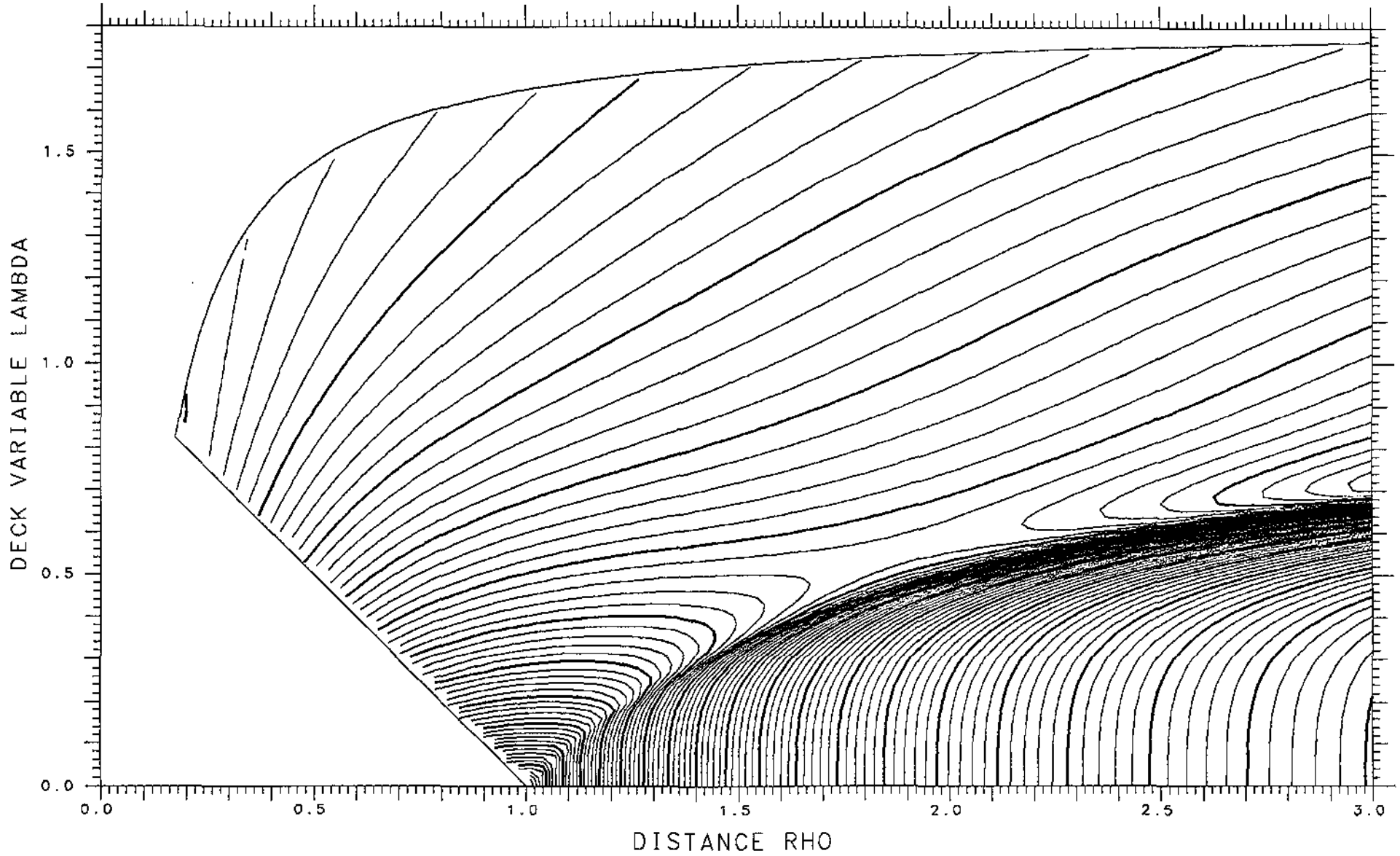

X= .775 ASYMMETRY DELTA= .375 FRACTIONAL= .9141

SPHERES -.05295 TANGENT .09067 LENGTH 10.677 ENERGY 627.05 SPACING .002 SADDLE .06301

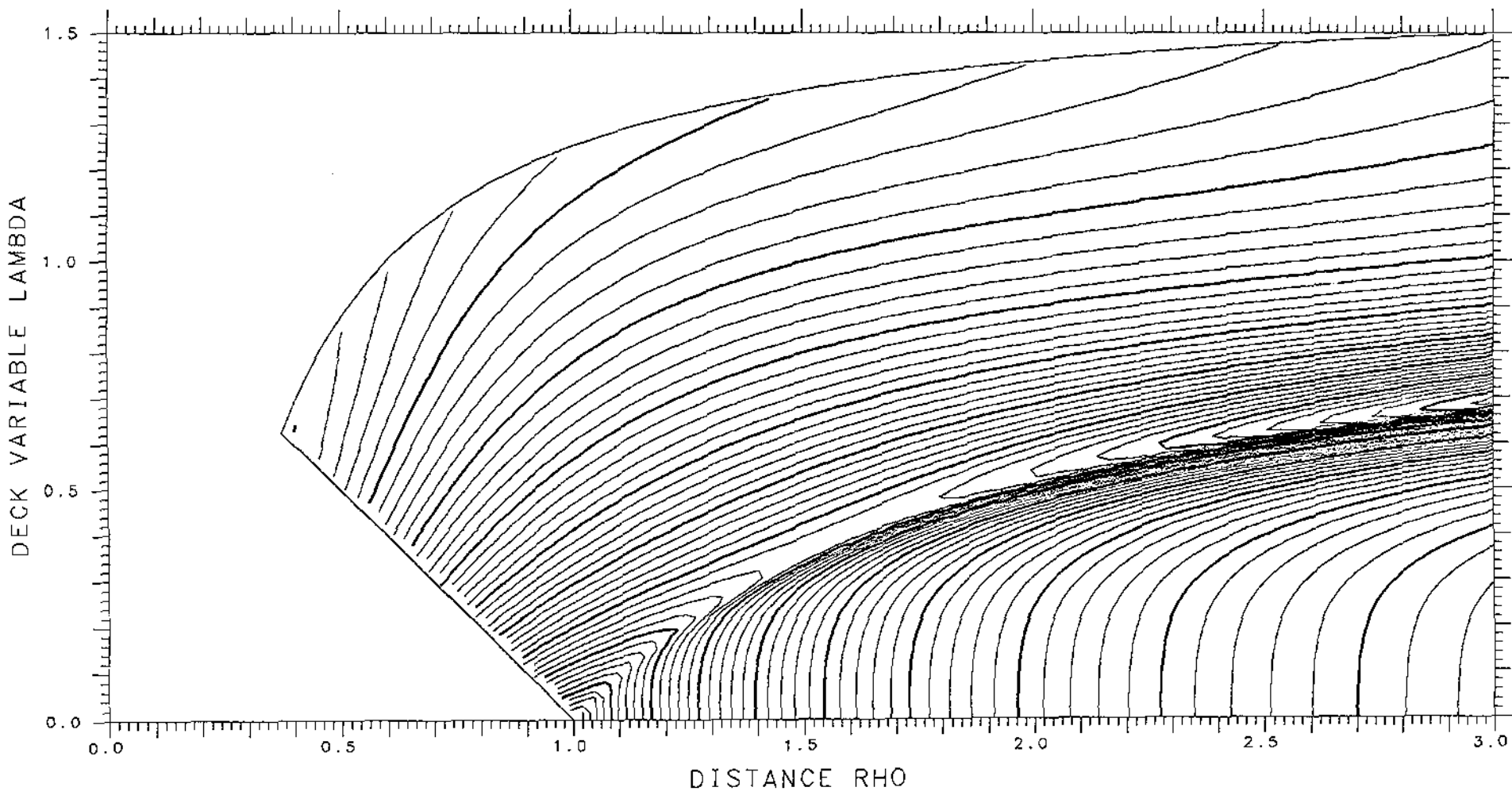

X= .700 ASYMMETRY DELTA= .200 FRACTIONAL= .7714

SPHERES -.15698 TANGENT .11218 LENGTH 11.097 ENERGY 583.53 SPACING .002 SADDLE .04826

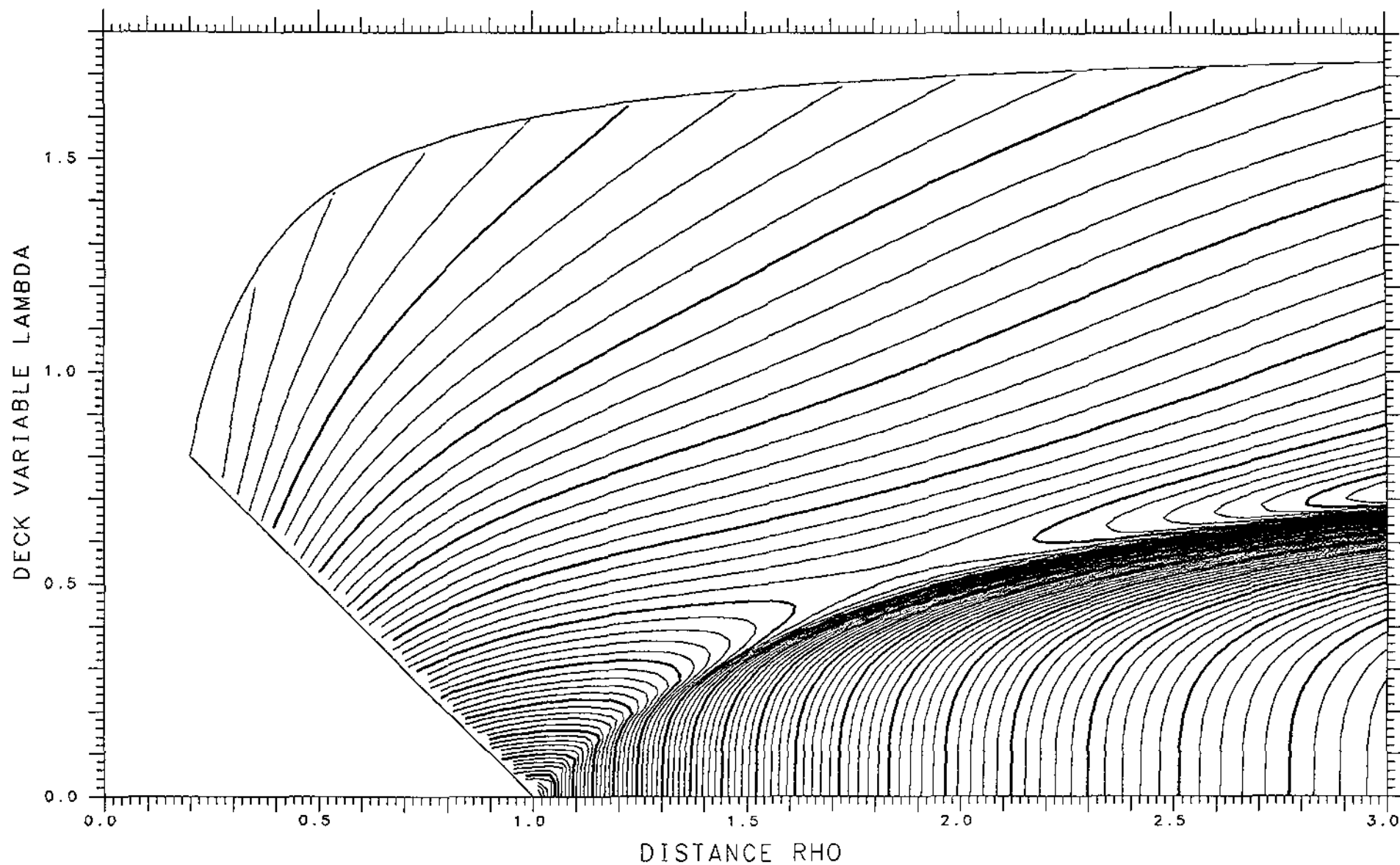

X= .775 ASYMMETRY DELTA= .350 FRACTIONAL= .8996

SPHERES -.06907 TANGENT .09409 LENGTH 10.817 ENERGY 627.05 SPACING .002 SADDLE .06062

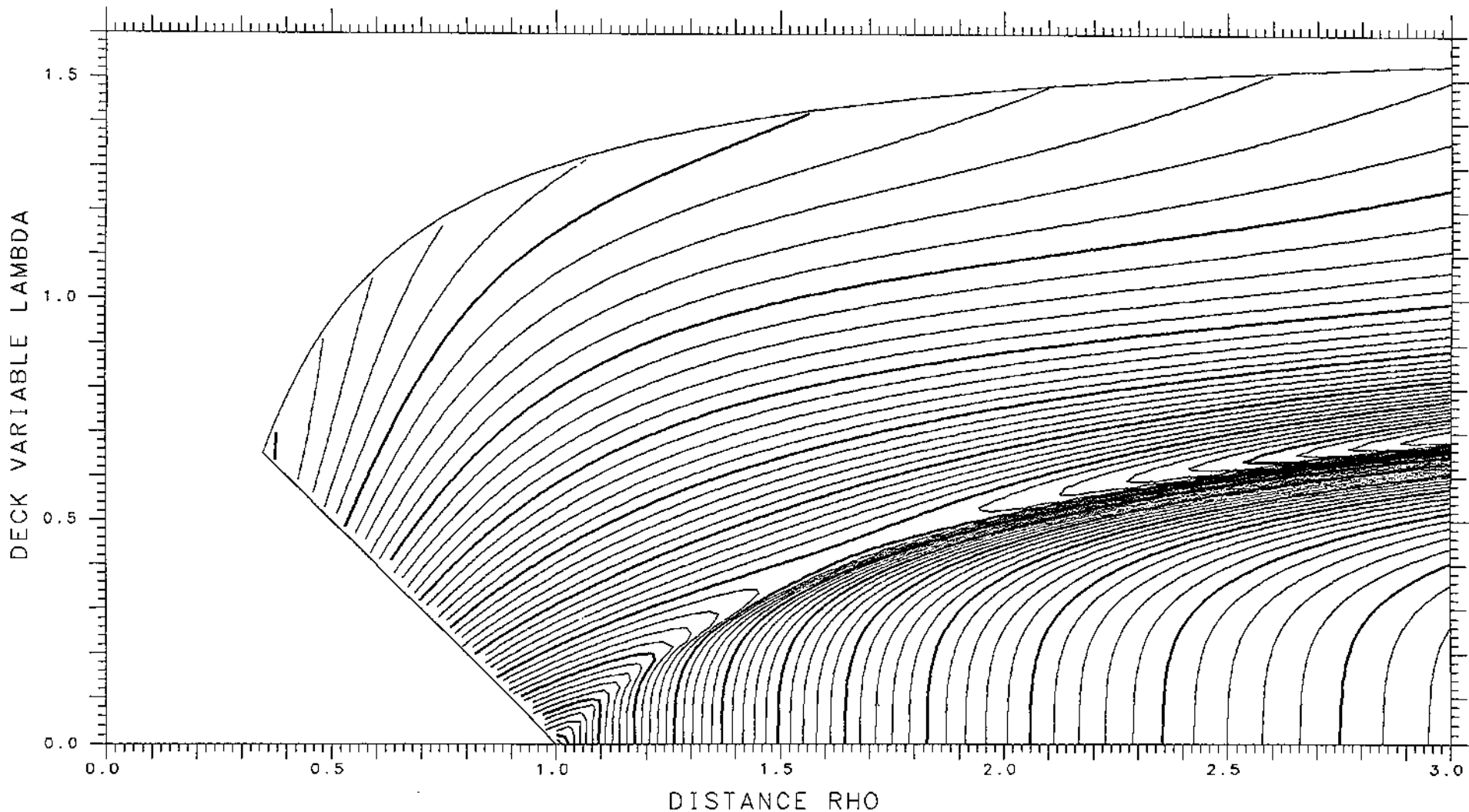

X= .700 ASYMMETRY DELTA= .225 FRACTIONAL= .7979

SPHERES -.13691 TANGENT .11152 LENGTH 10.994 ENERGY 583.53 SPACING .002 SADDLE .05361

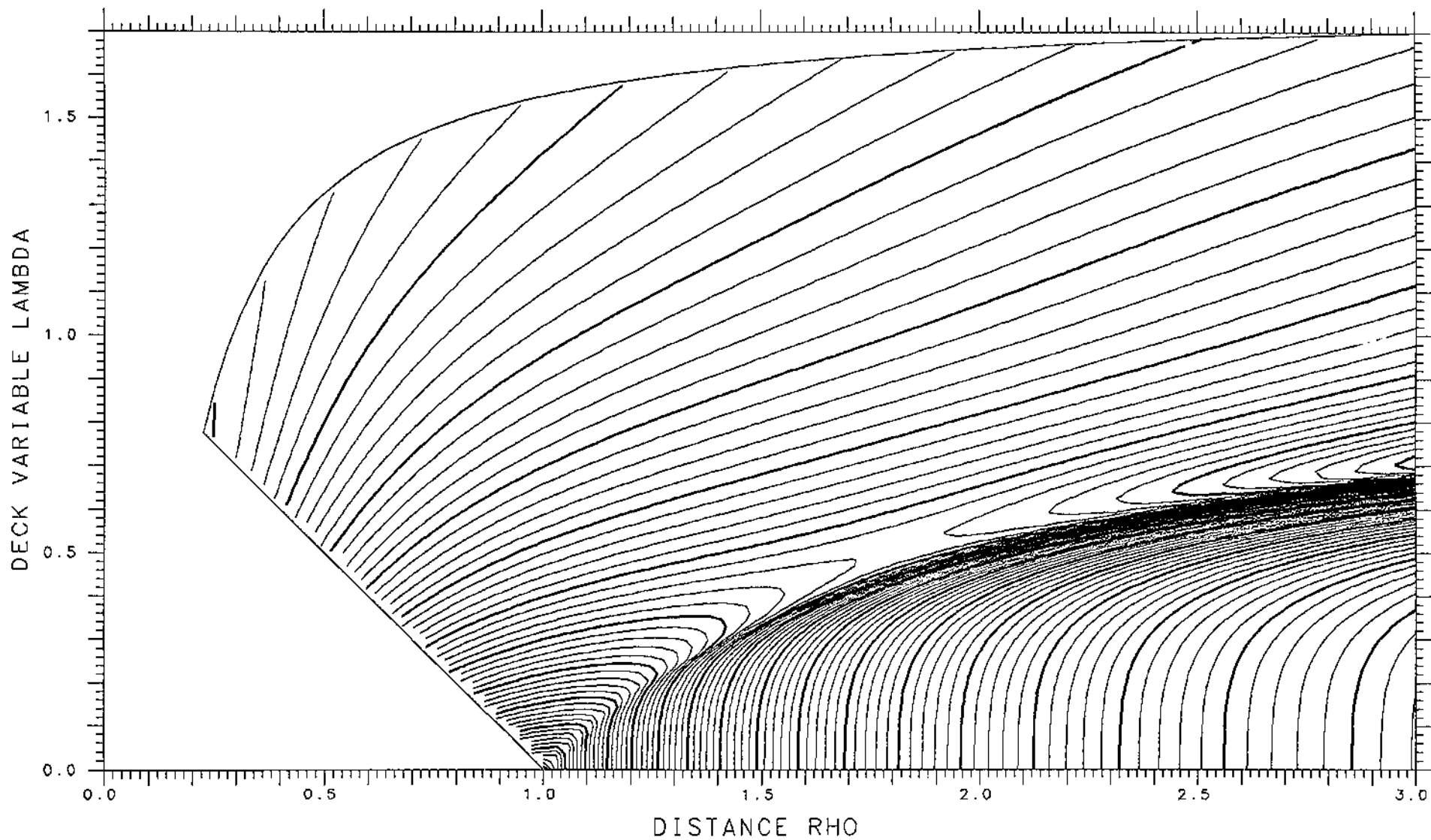

X= .775 ASYMMETRY DELTA= .325 FRACTIONAL= .8832

SPHERES -.08706 TANGENT .09691 LENGTH 10.954 ENERGY 627.05 SPACING .002 SADDLE .05695

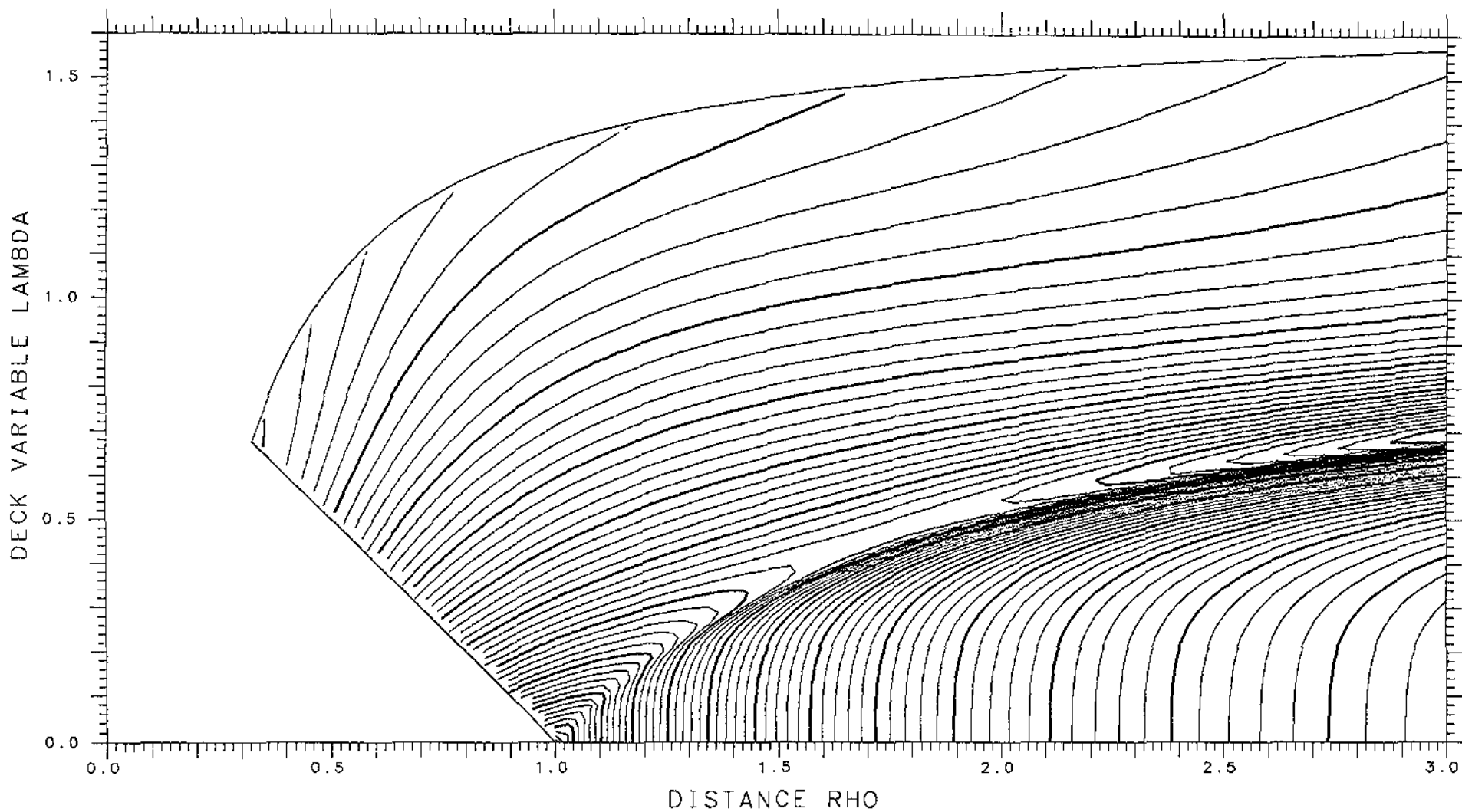

X= .700 ASYMMETRY DELTA= .250 FRACTIONAL= .8224

SPHERES -.11708 TANGENT .11031 LENGTH 10.883 ENERGY 583.53 SPACING .002 SADDLE .05899

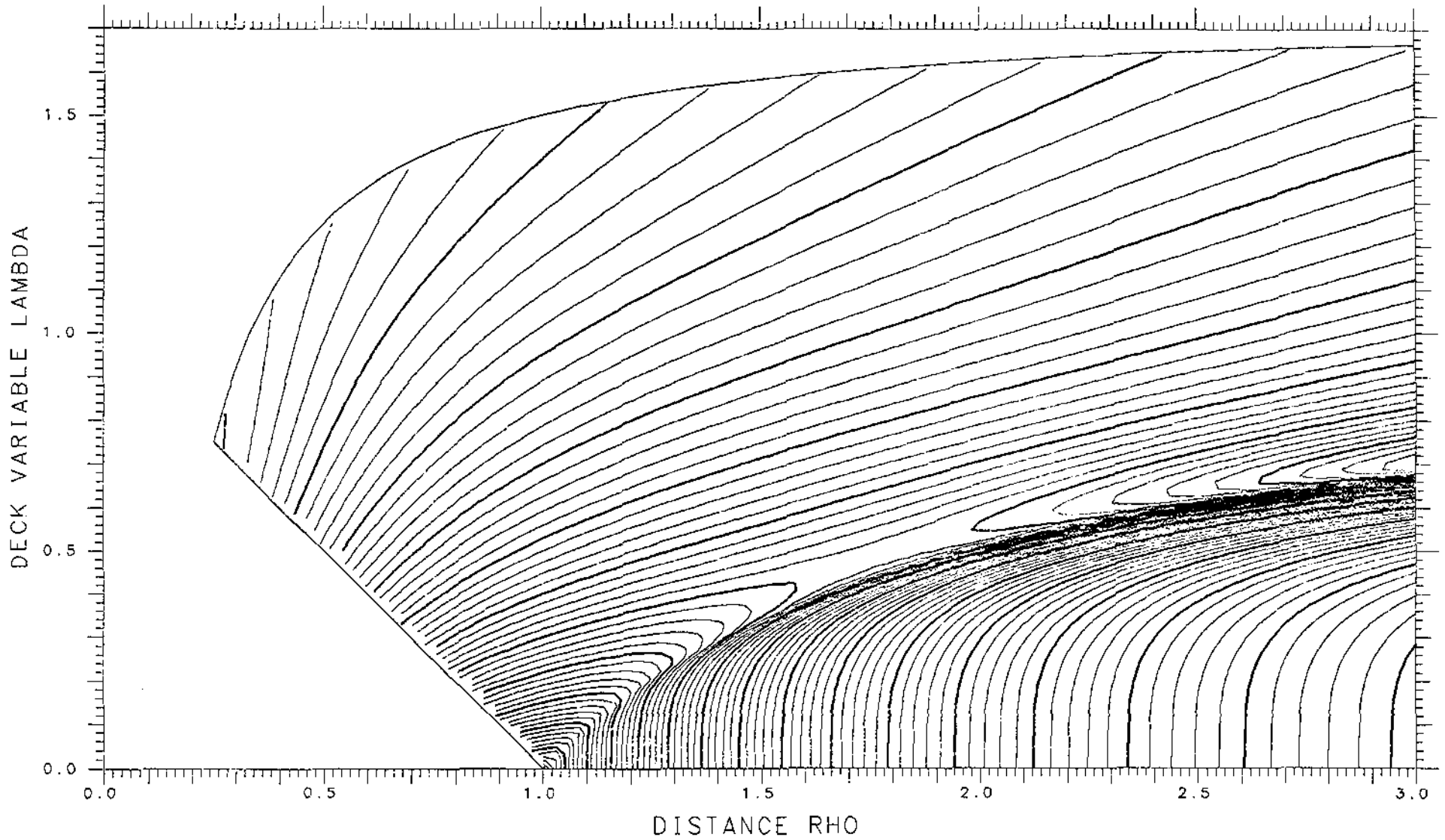

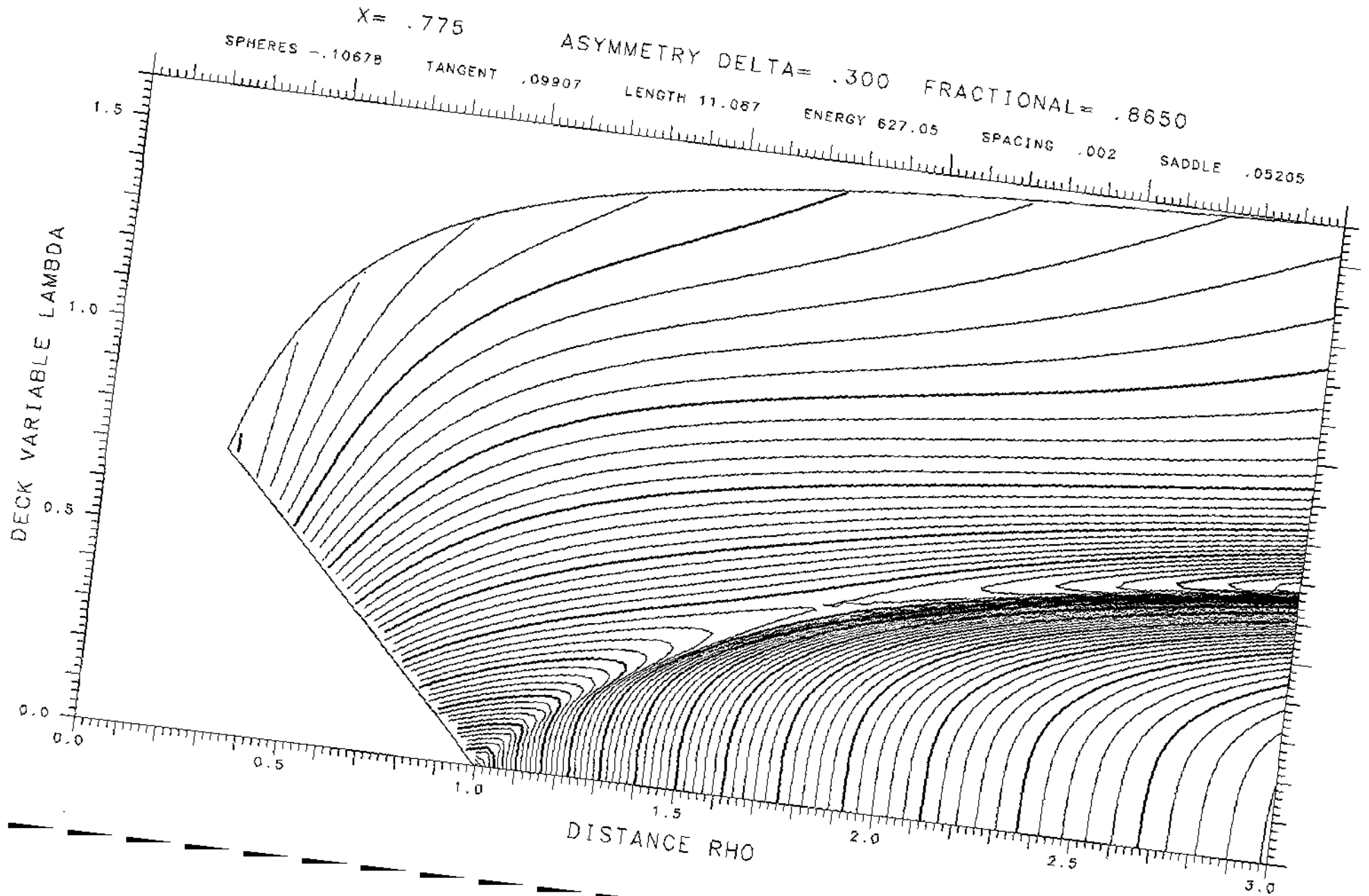

X= .700 ASYMMETRY DELTA= .275 FRACTIONAL= .8447

SPHERES -.09795 TANGENT .10848 LENGTH 10.765 ENERGY 583.53 SPACING .002 SADDLE .06354

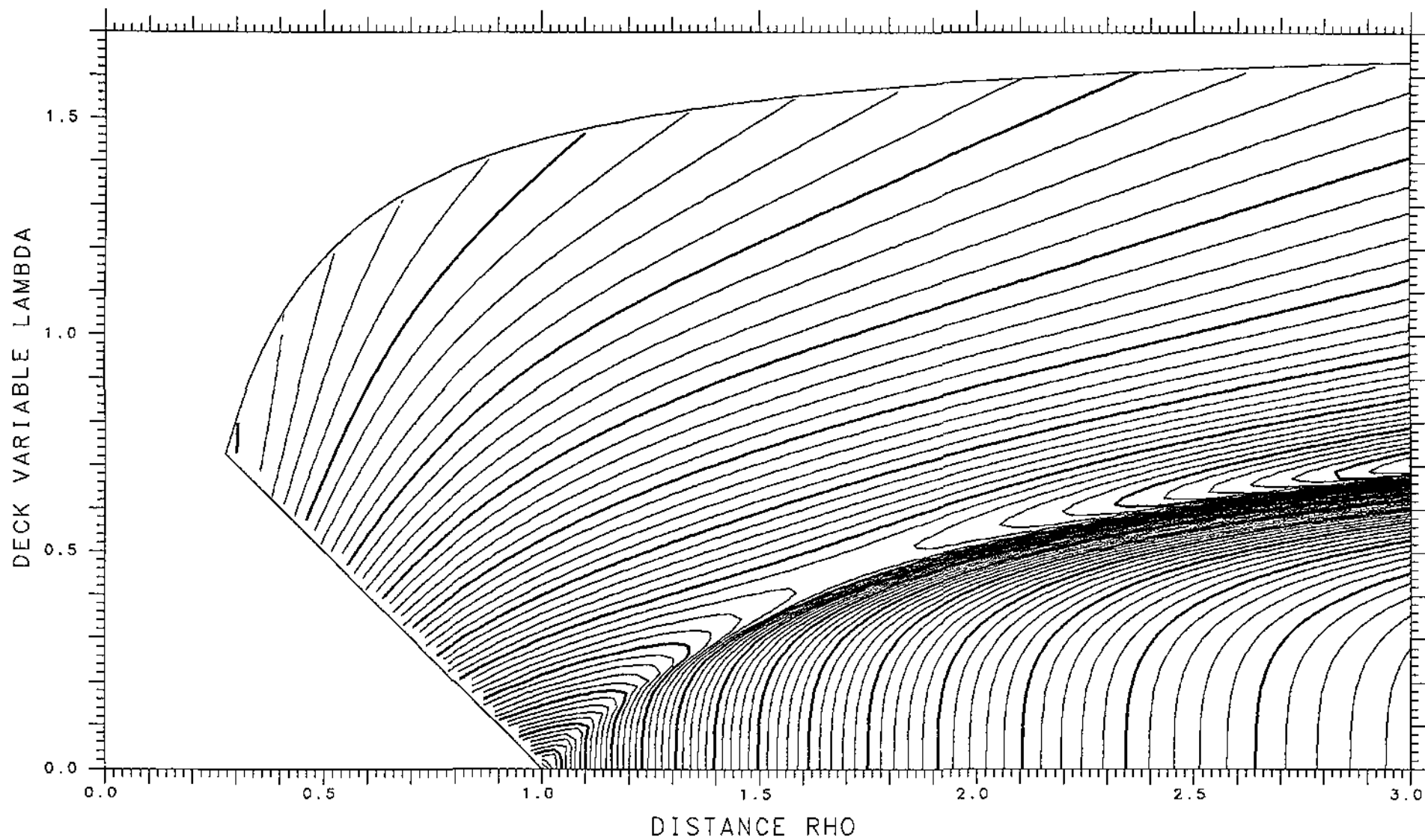

X= .775 ASYMMETRY DELTA= .275 FRACTIONAL= .8447

SPHERES -.12800 TANGENT .10055 LENGTH 11.215 ENERGY 627.05 SPACING .002 SADDLE .04604

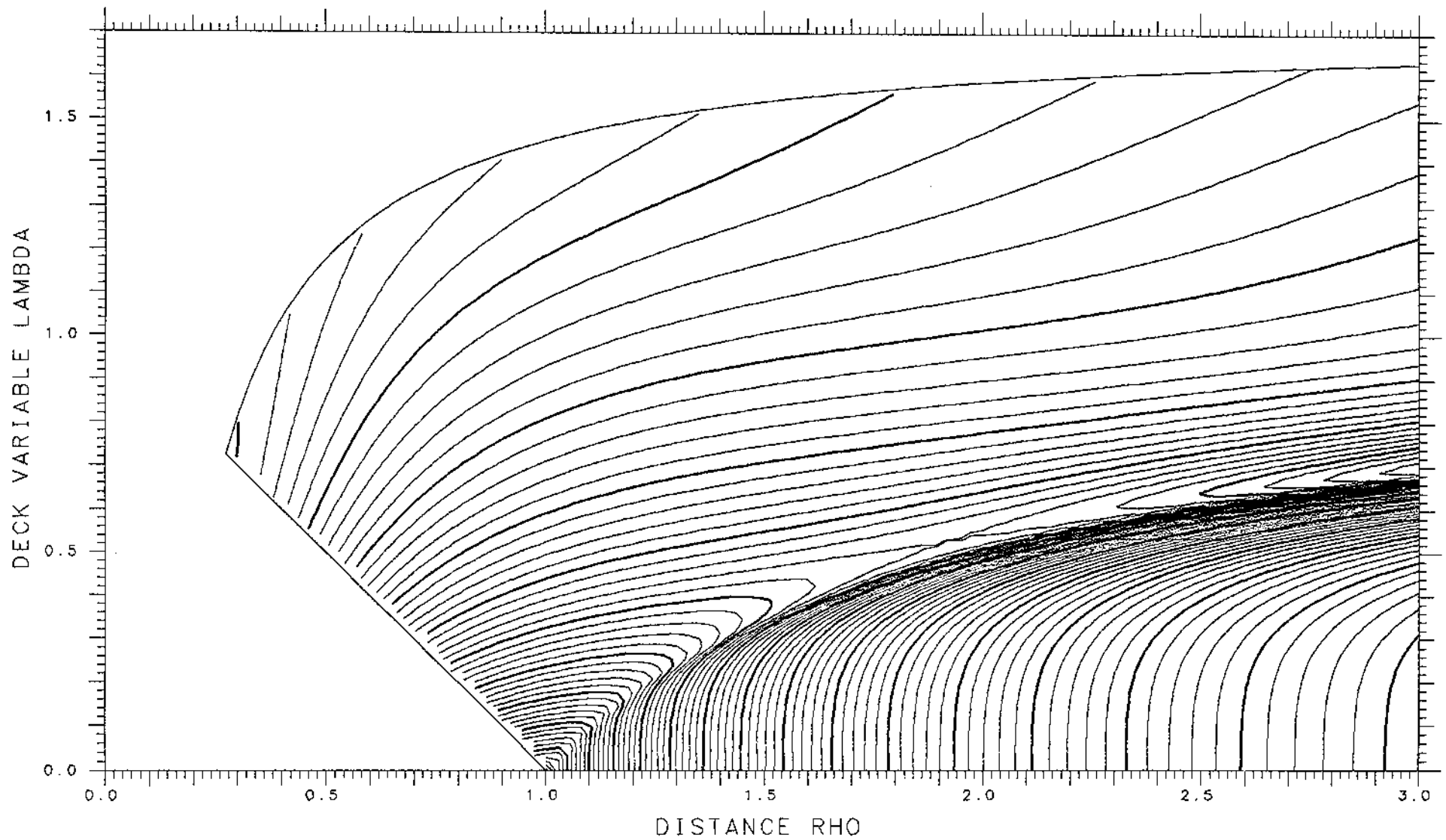

X= .700 ASYMMETRY DELTA= .300 FRACTIONAL= .8650

SPHERES -.07990 TANGENT .10603 LENGTH 10.642 ENERGY 583.53 SPACING .002 SADDLE .06724

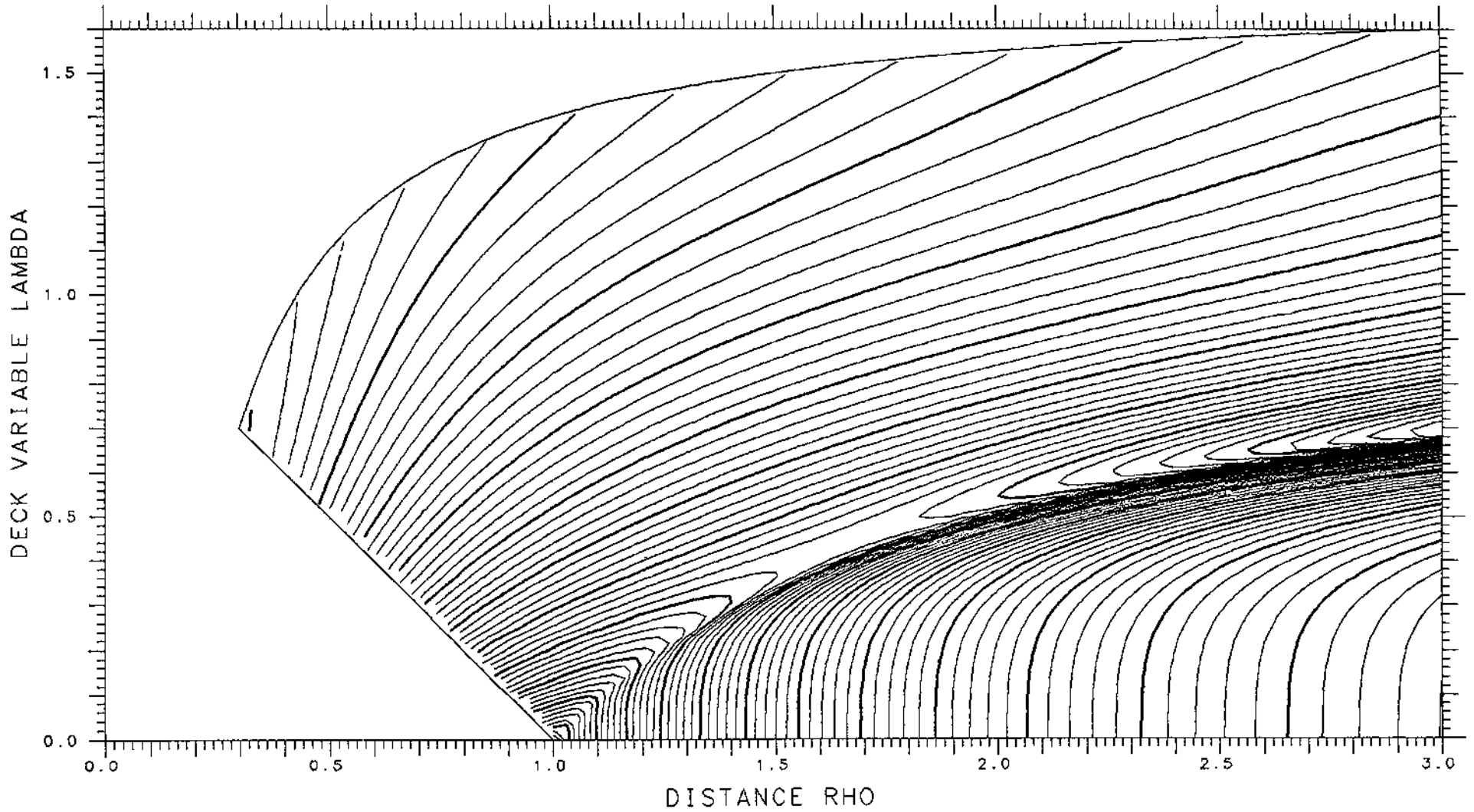

X= .775
SPHERES -.15038 ASYMMETRY DELTA= .250
TANGENT .10136 LENGTH 11.338 ENERGY 627.05
FRACTIONAL= .8224
SPACING .002 SADDLE .03814

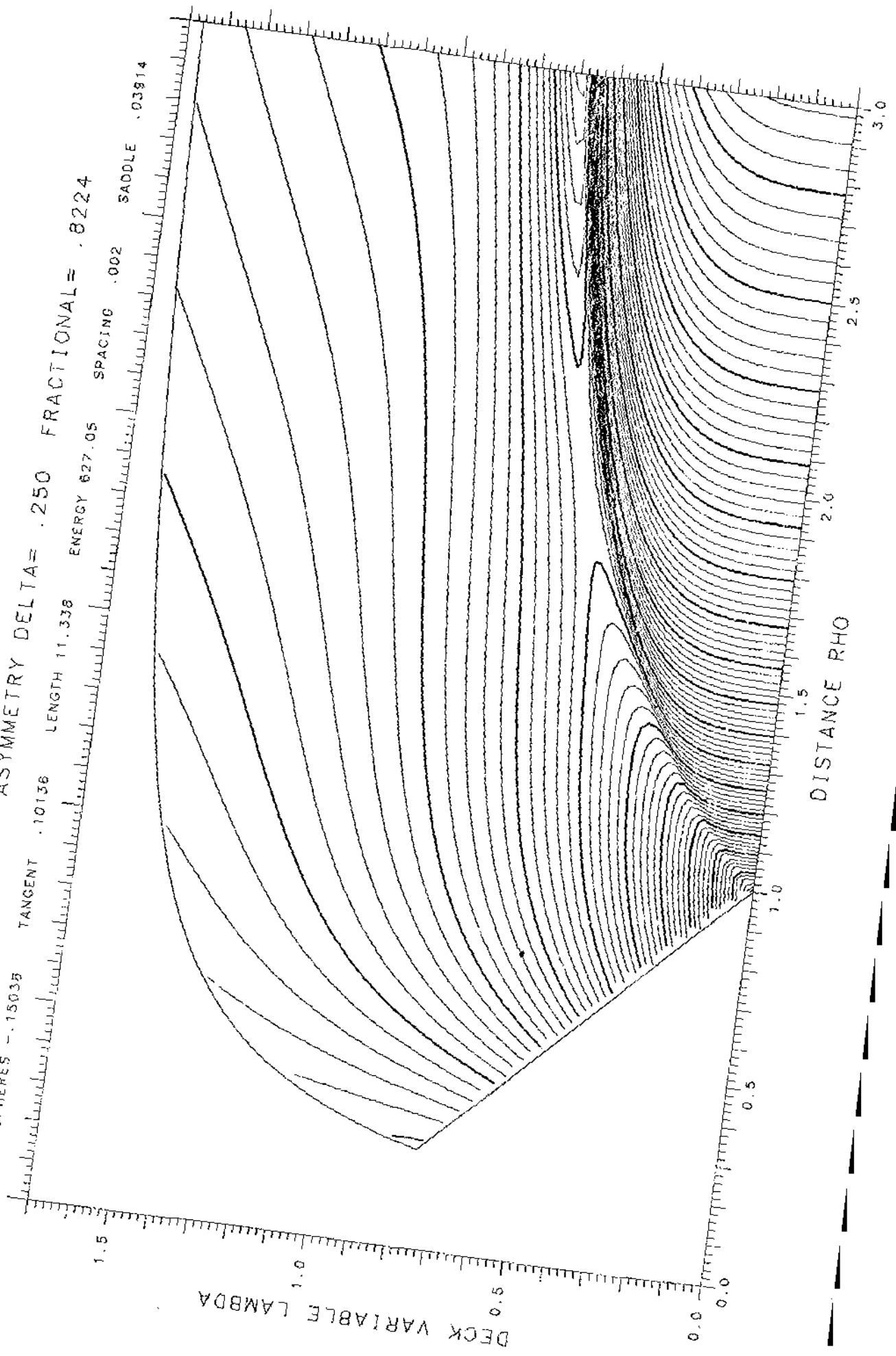

X= .700 ASYMMETRY DELTA= .325 FRACTIONAL= .8832

SPHERES -.06320 TANGENT .10296 LENGTH 10.514 ENERGY 583.53 SPACING .002 SADDLE .06995

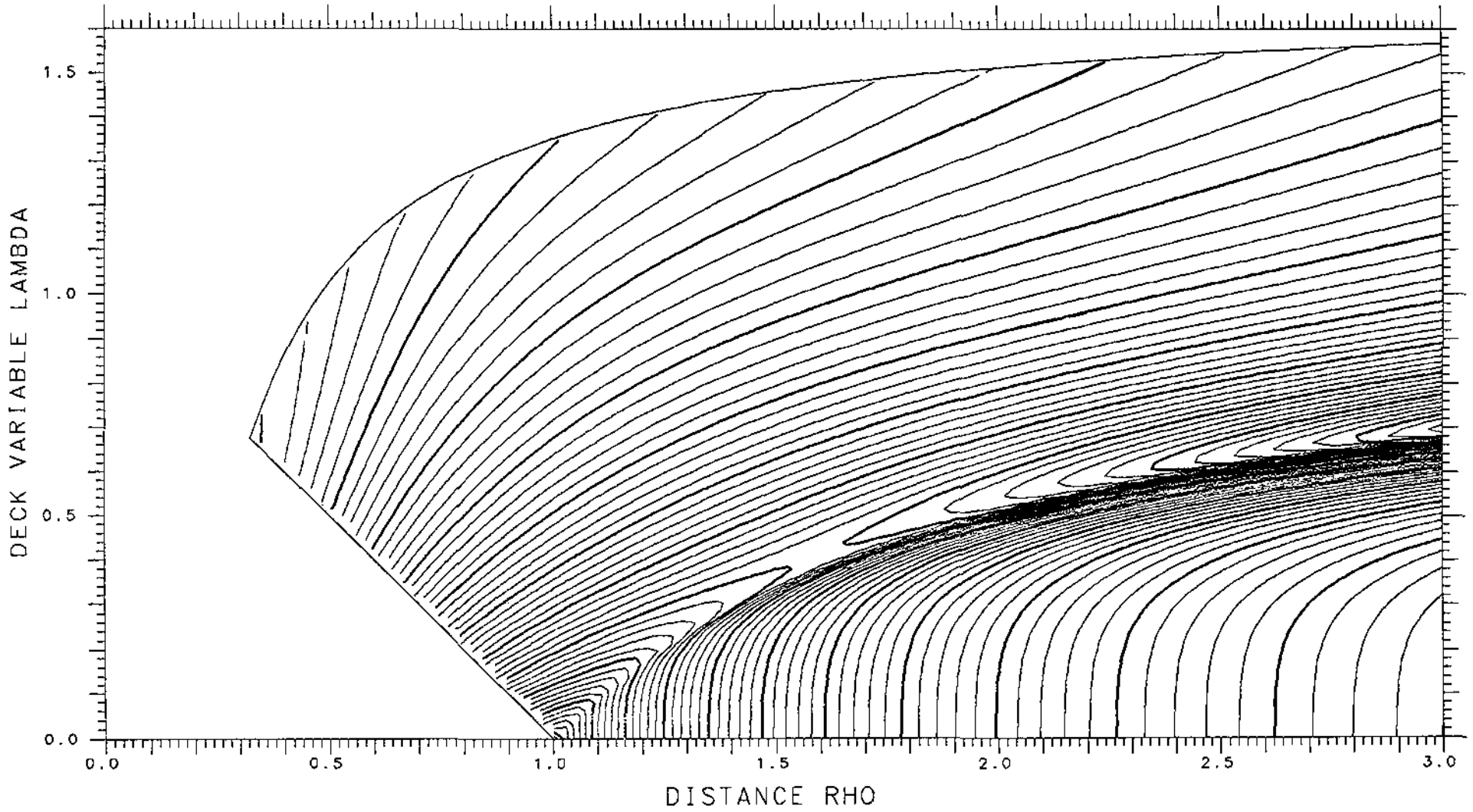

X= .775 ASYMMETRY DELTA= .225 FRACTIONAL= .7979

SPHERES -.17350 TANGENT .10155 LENGTH 11.454 ENERGY 627.05 SPACING .002 SADDLE .03185

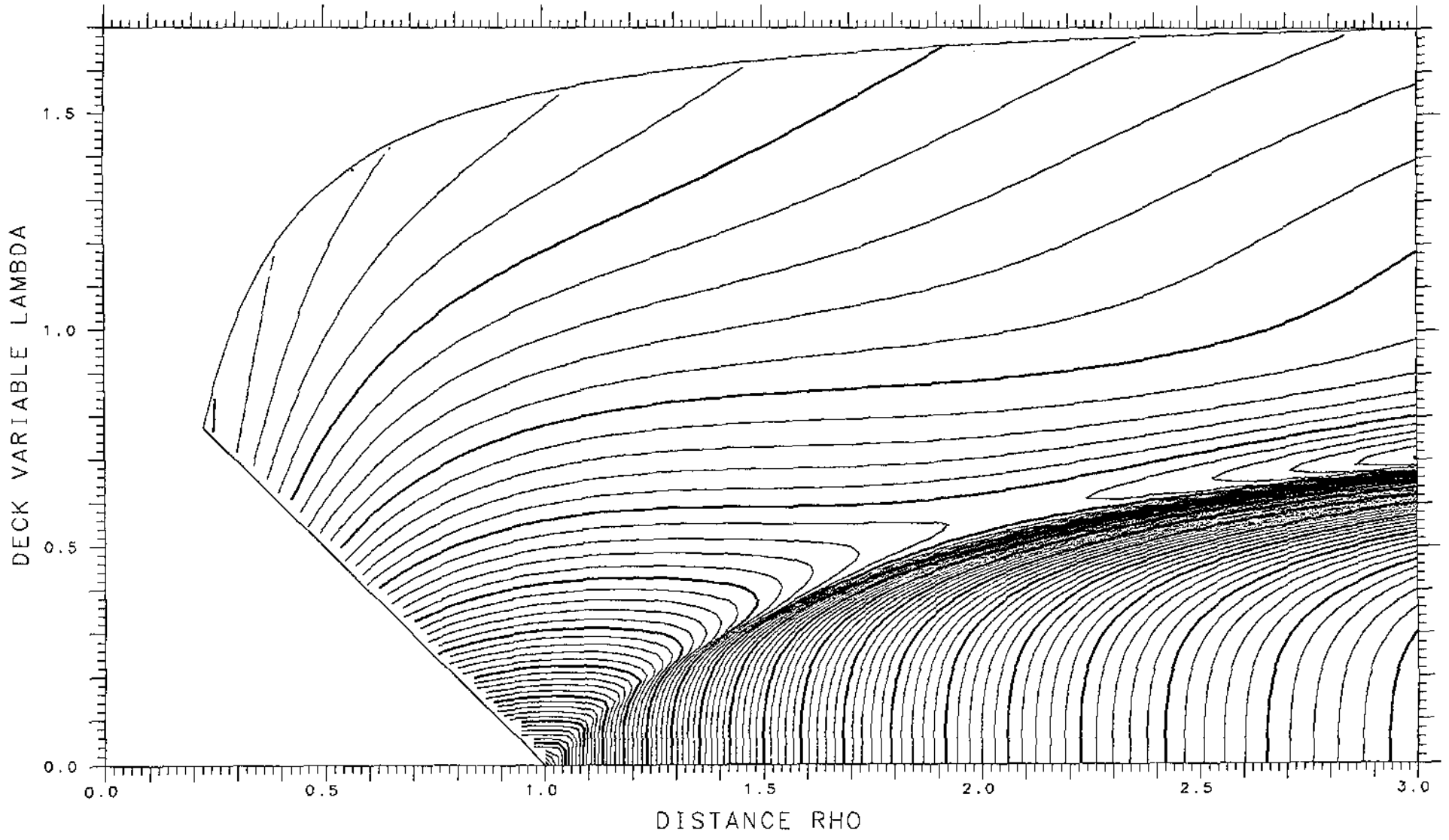

X= .700 ASYMMETRY DELTA= .350 FRACTIONAL= .8996

SPHERES -.04807 TANGENT .09930 LENGTH 10.383 ENERGY 583.53 SPACING .002 SADDLE .07160

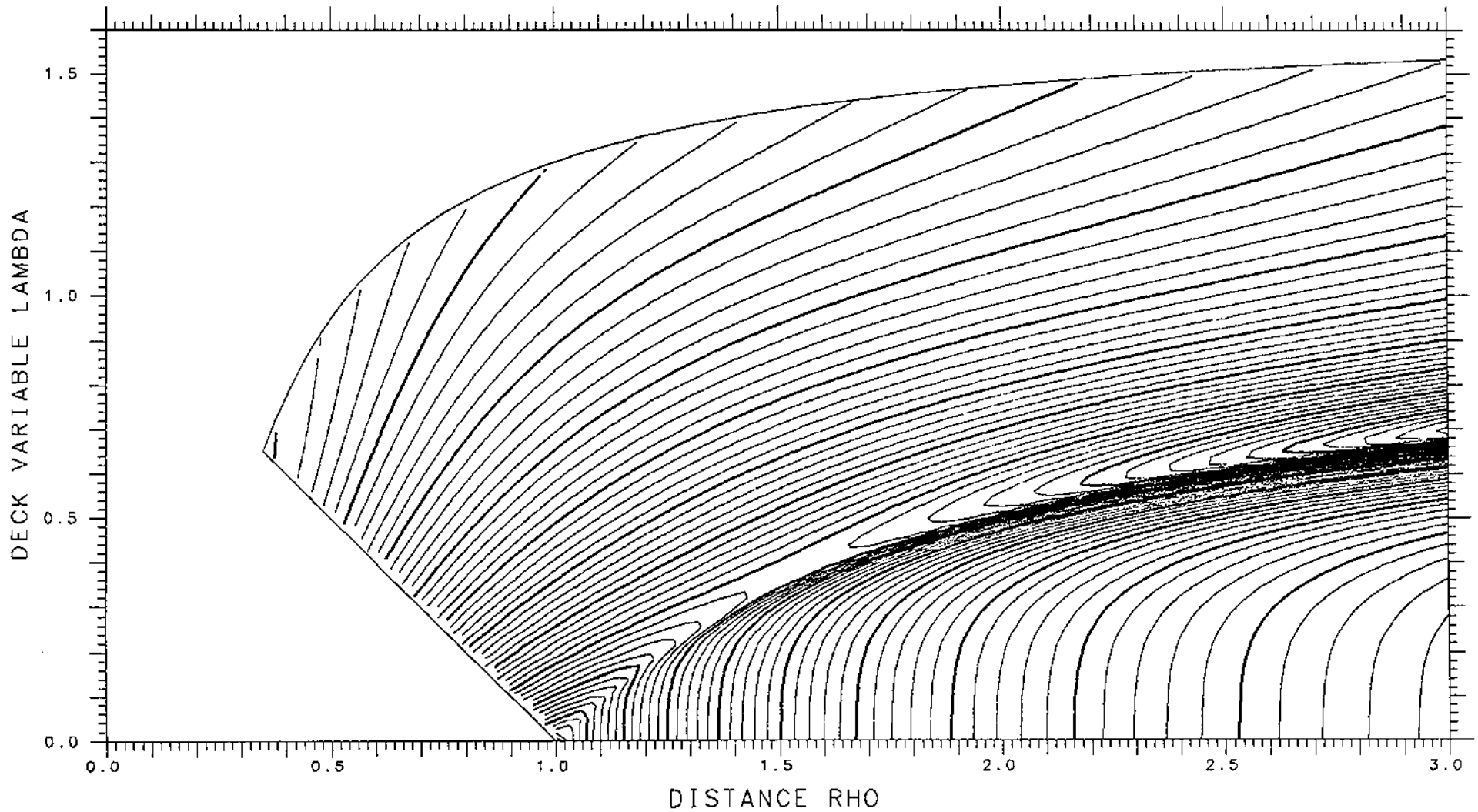

X= .775 ASYMMETRY DELTA= .200 FRACTIONAL= .7714

SPHERES -.19683 TANGENT .10117 LENGTH 11.561 ENERGY 627.05 SPACING .002 SADDLE .02395

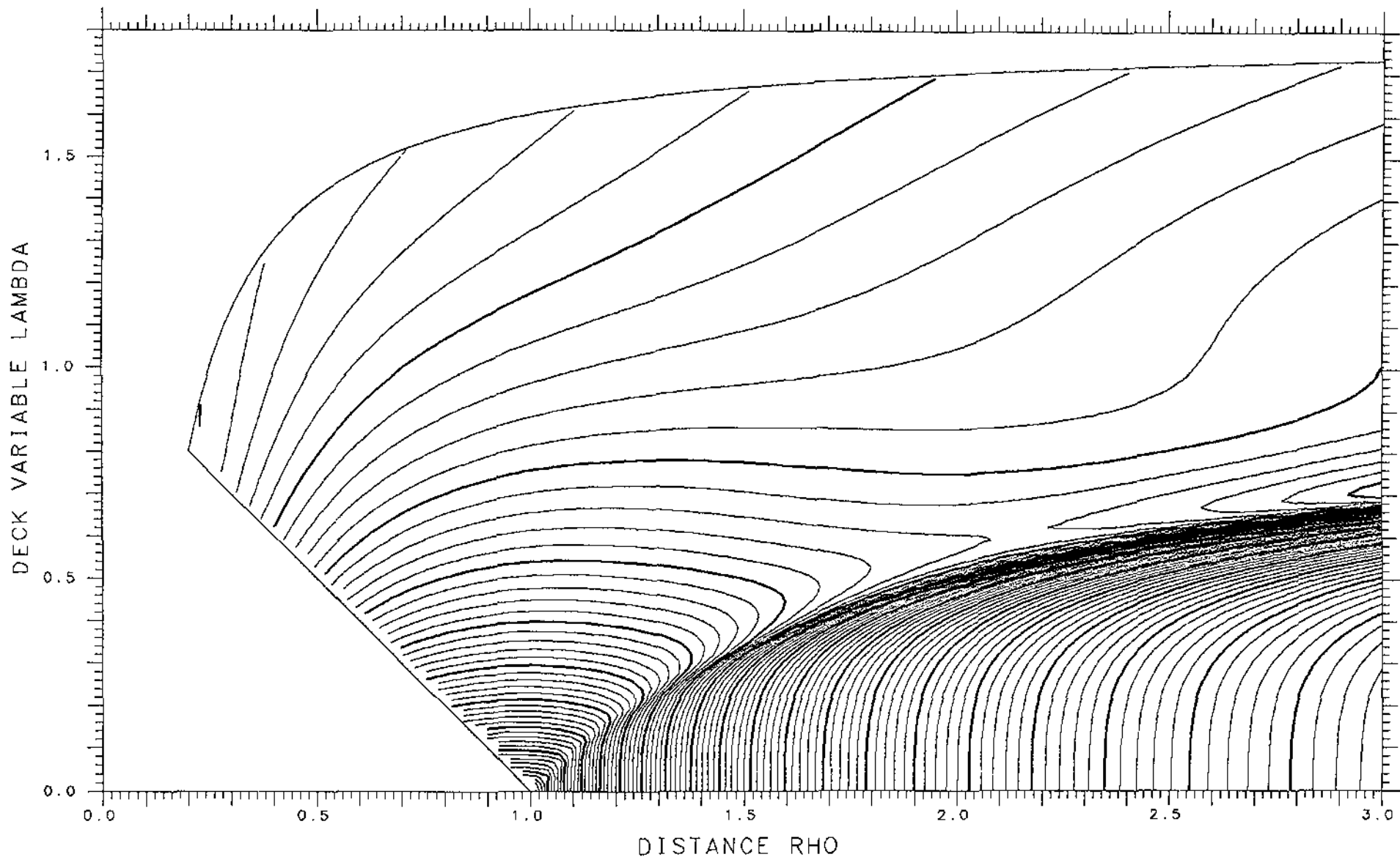

X= .700 ASYMMETRY DELTA= .375 FRACTIONAL= .9141

SPHERES -.03462 TANGENT .09510 LENGTH 10.249 ENERGY 583.53 SPACING .002 SADDLE .07217

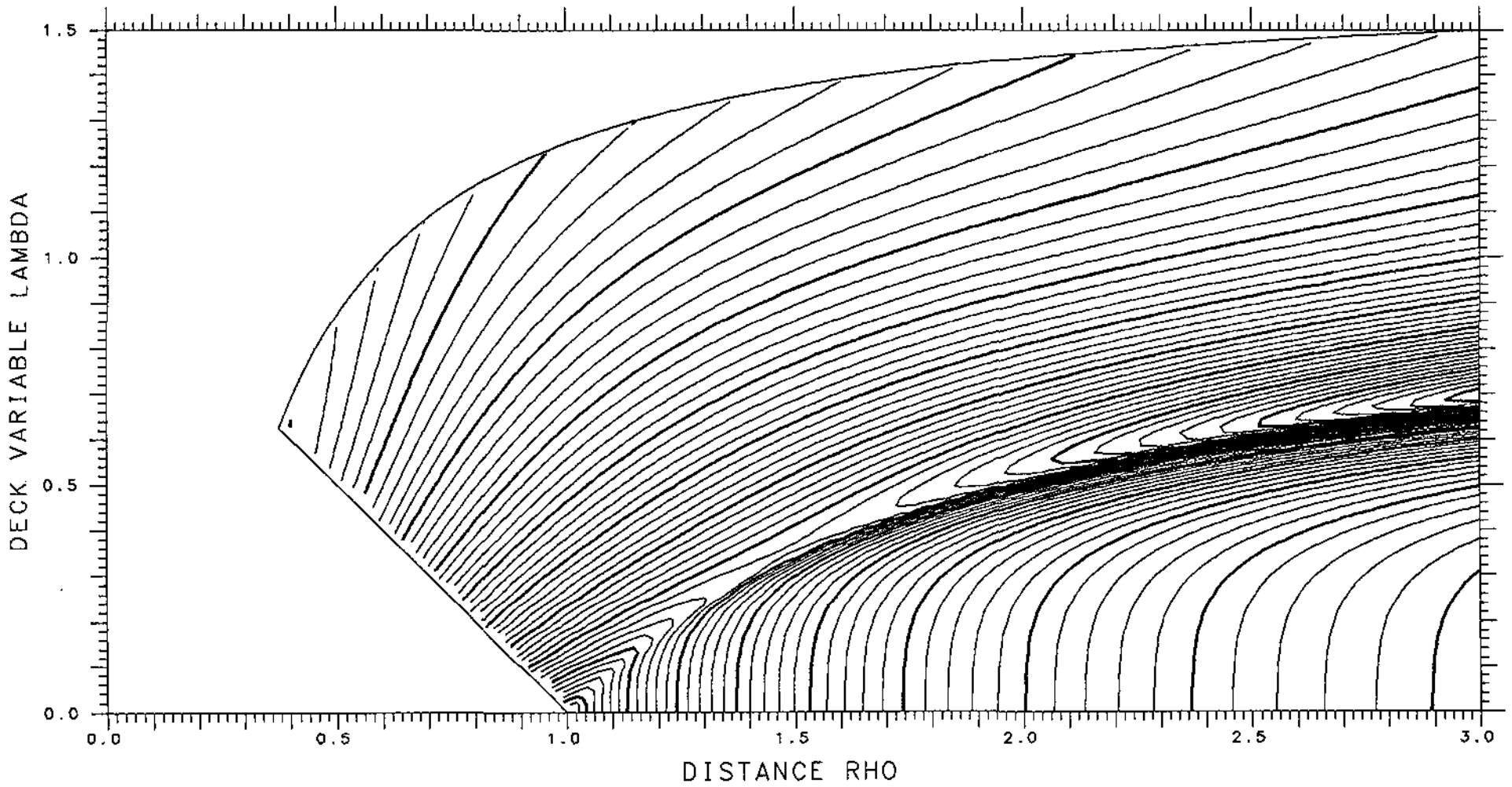

X= .775 ASYMMETRY DELTA= .175 FRACTIONAL= .7429

SPHERES -.21978 TANGENT .10033 LENGTH 11.660 ENERGY 627.05 SPACING .002 SADDLE .01658

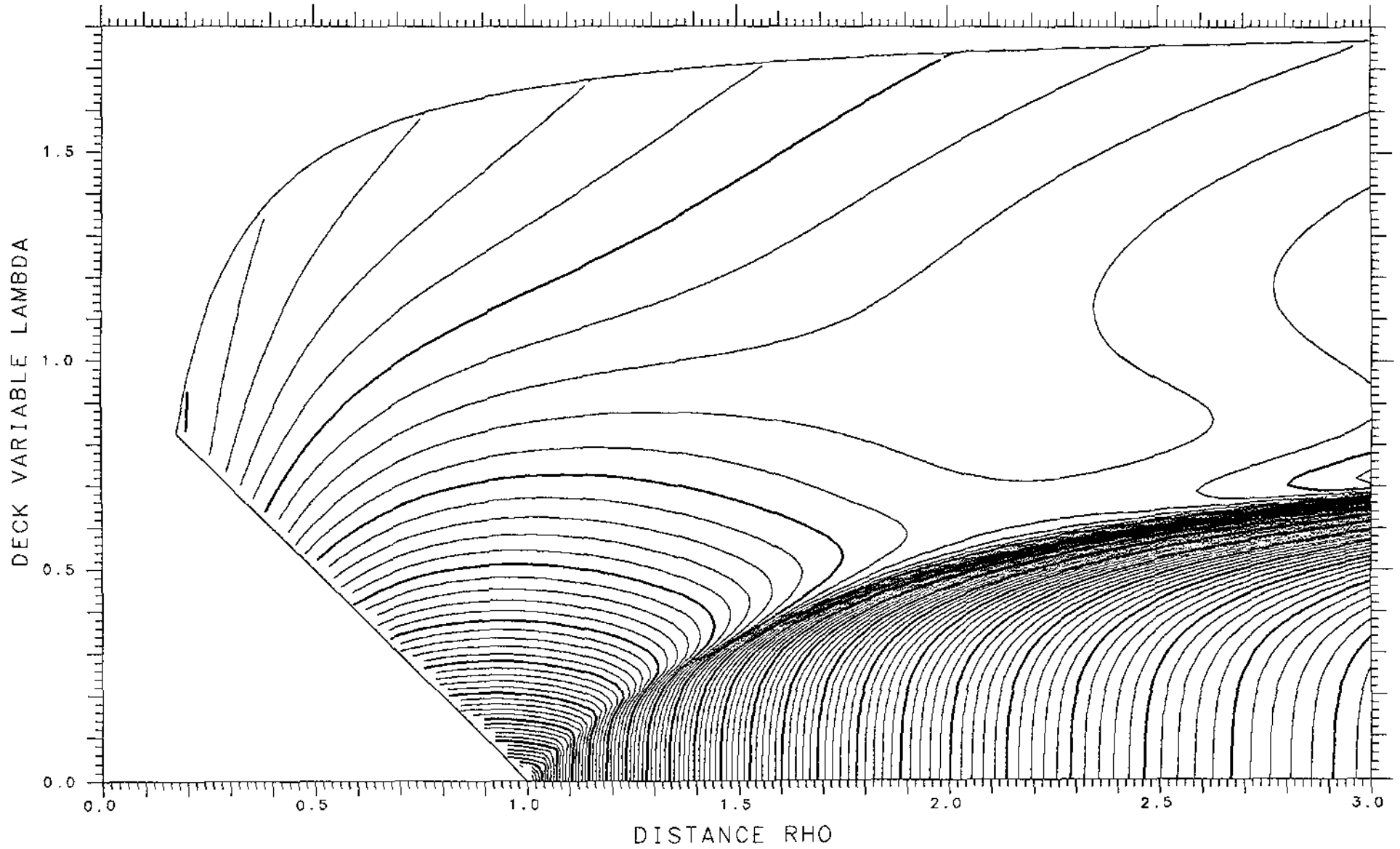

X= .700 ASYMMETRY DELTA= .400 FRACTIONAL= .9270

SPHERES -.02289 TANGENT .09043 LENGTH 10.113 ENERGY 583.53 SPACING .002 SADDLE .07171

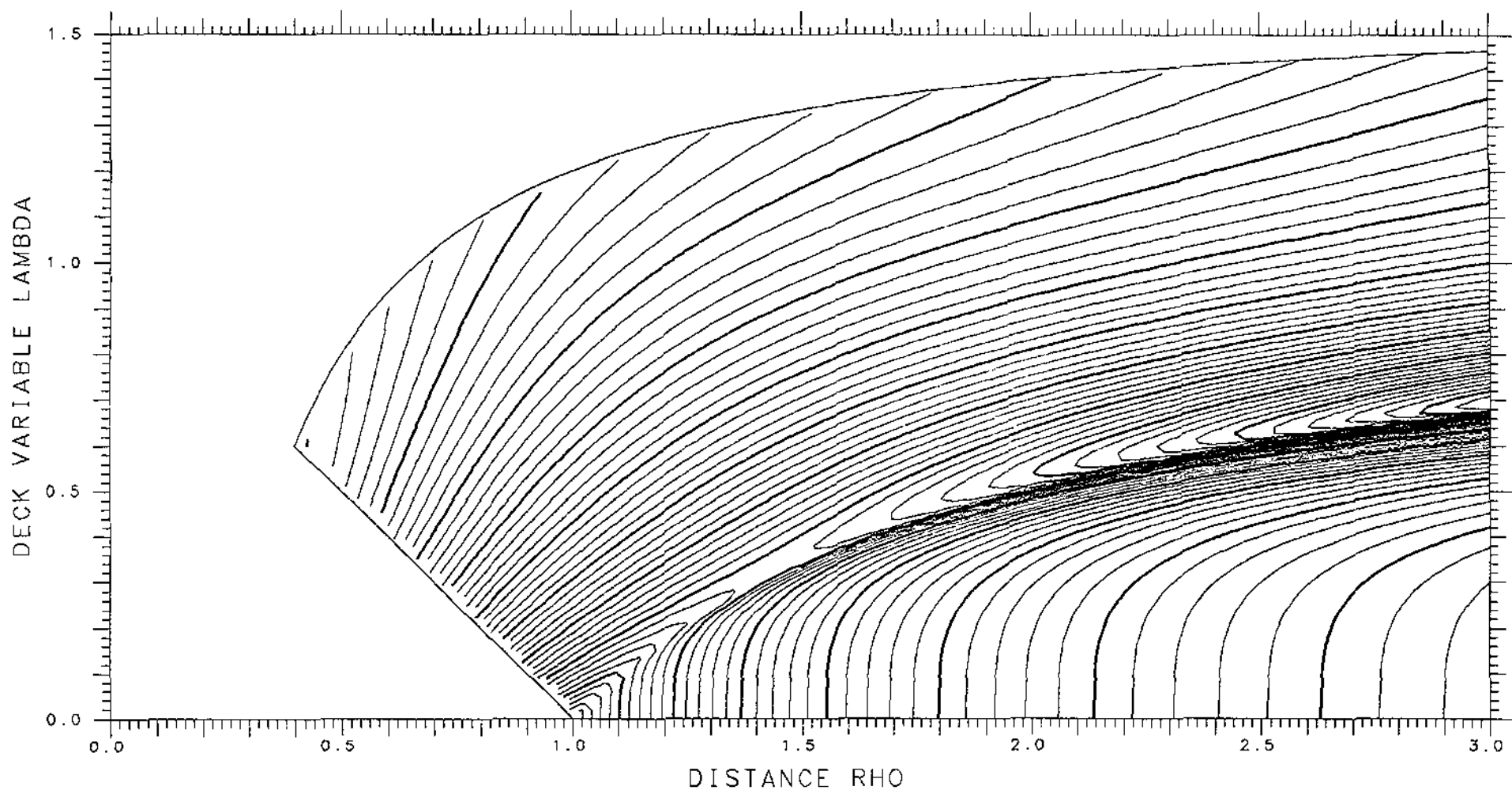

X= .775

ASYMMETRY DELTA= .150

FRACTIONAL= .7124

SPHERES -.24165

TANGENT .09915

LENGTH 11.748

ENERGY 627.05

SPACING .002

SADDLE .01346

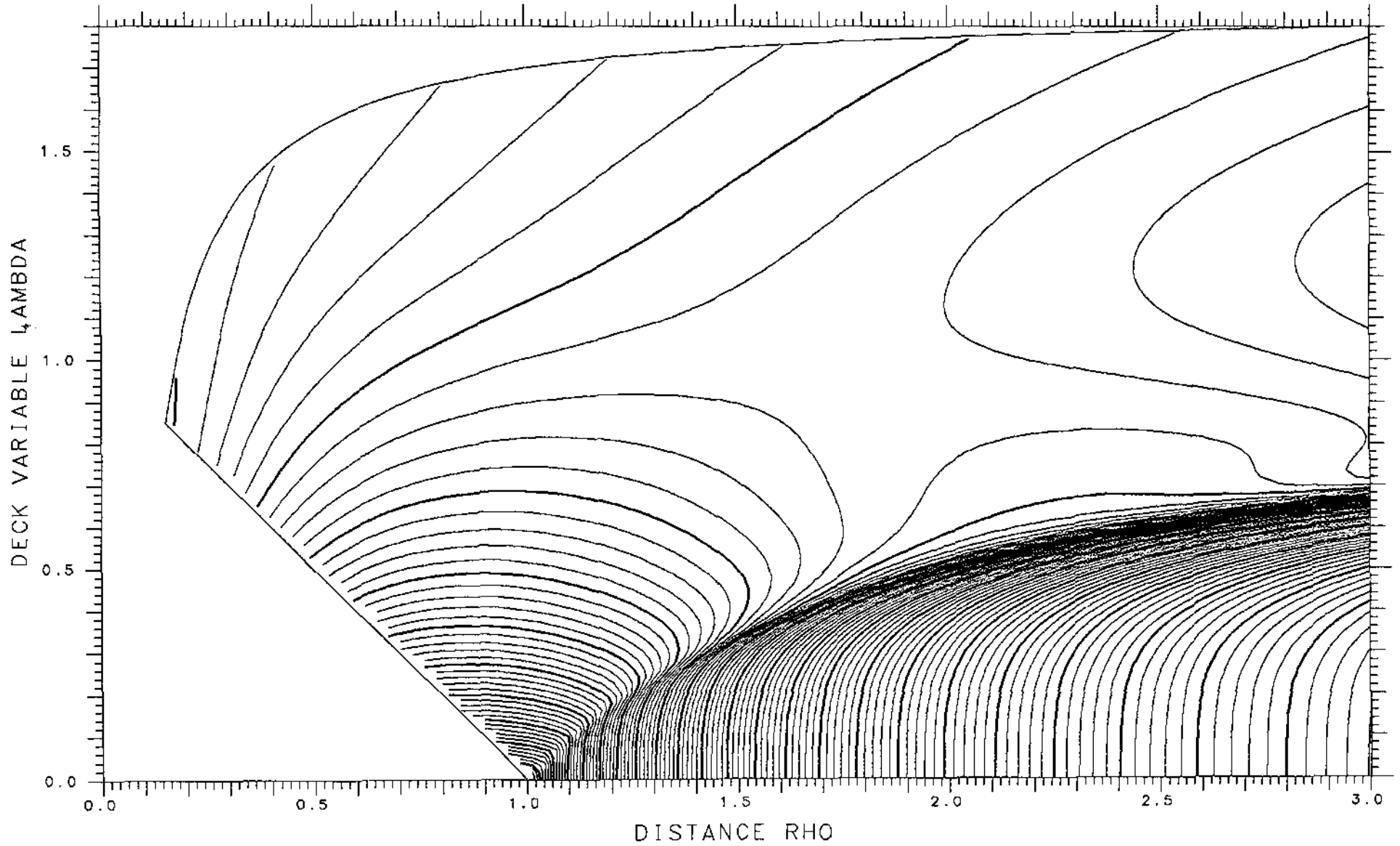

X= .700 ASYMMETRY DELTA= .425 FRACTIONAL= .9384

SPHERES -.01288 TANGENT .08536 LENGTH 9.976 ENERGY 583.53 SPACING .002 SADDLE .07029

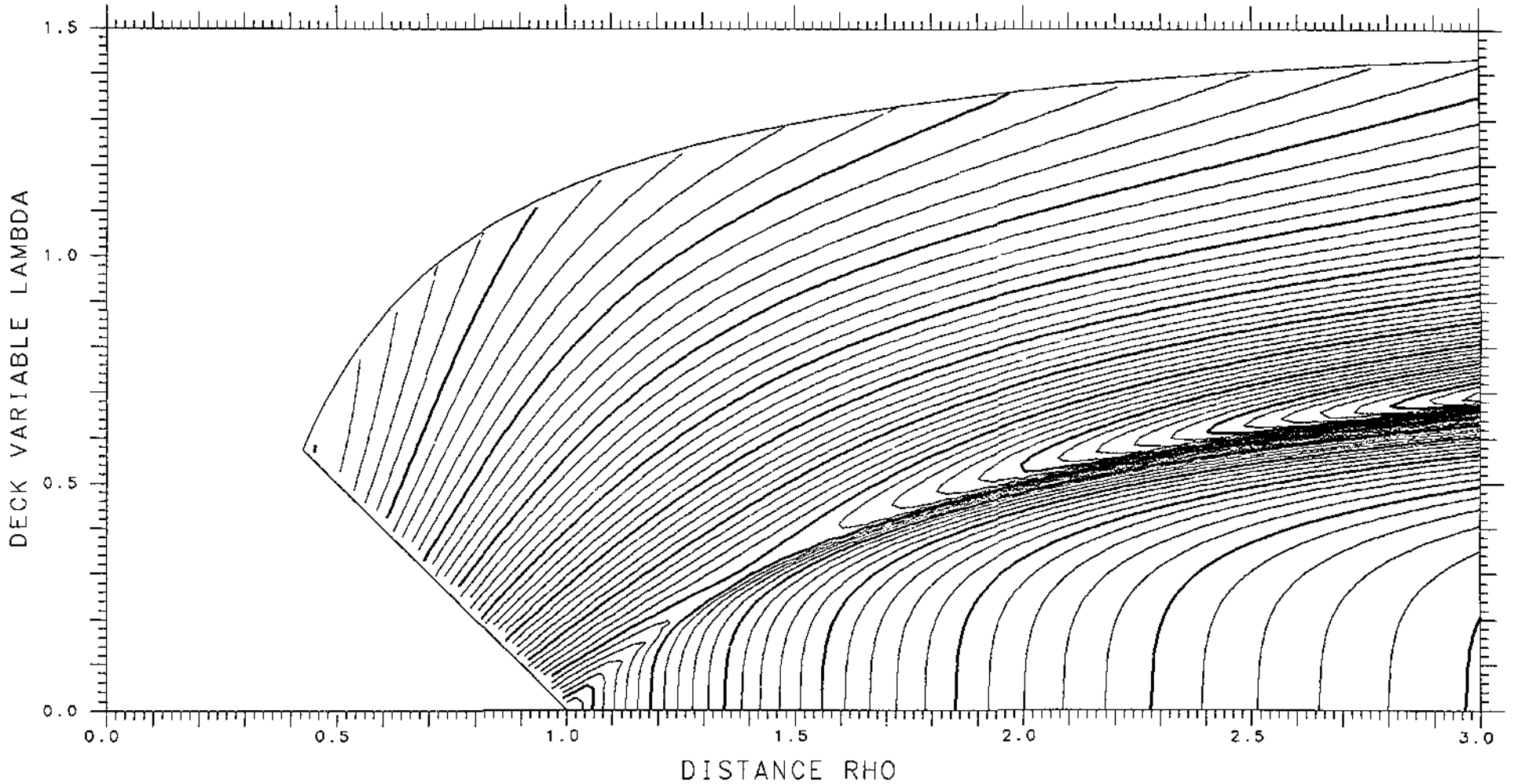

X= .775 ASYMMETRY DELTA= .125 FRACTIONAL= .6800

SPHERES -.26176 TANGENT .09779 LENGTH 11.824 ENERGY 627.05 SPACING .002 SADDLE .01225

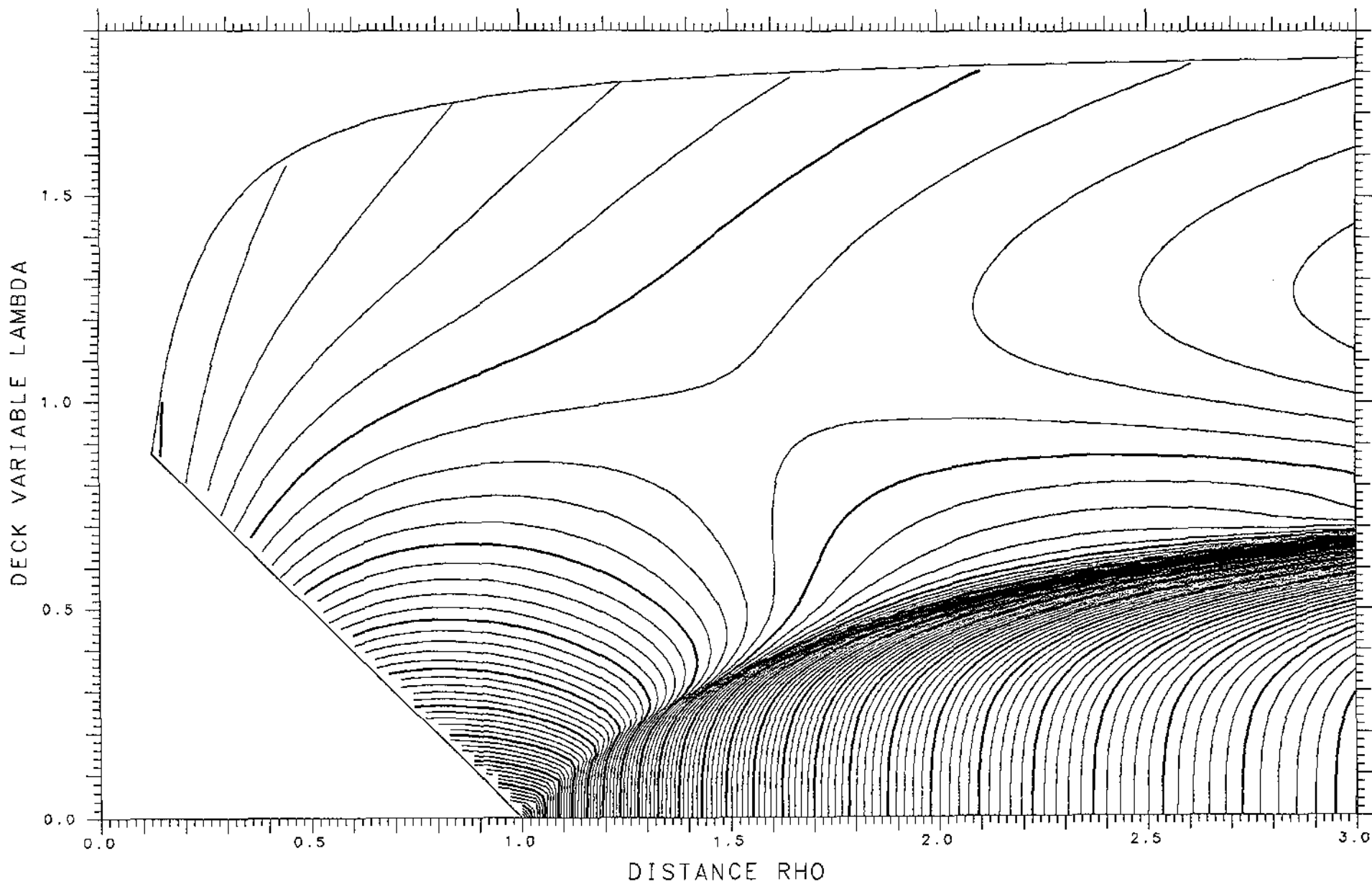

X= .700

ASYMMETRY DELTA= .450 FRACTIONAL= .9483

SPHERES -.00453

TANGENT .07997

LENGTH 9.838

ENERGY 583.53

SPACING .002

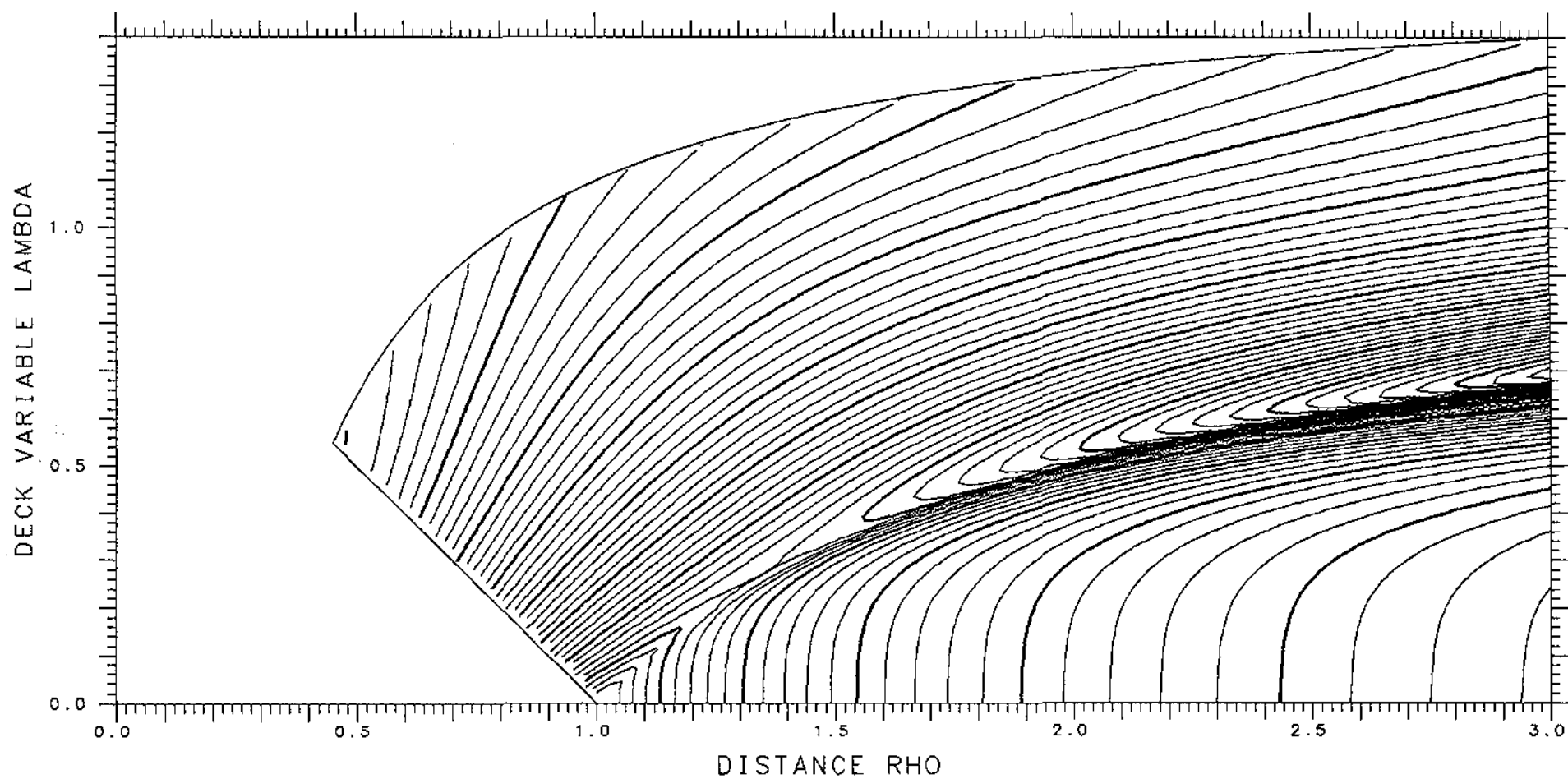

X= .775 ASYMMETRY DELTA= .100 FRACTIONAL= .6461

SPHERES -.27940 TANGENT .09639 LENGTH 11.889 ENERGY 627.05 SPACING .002 SADDLE .01132

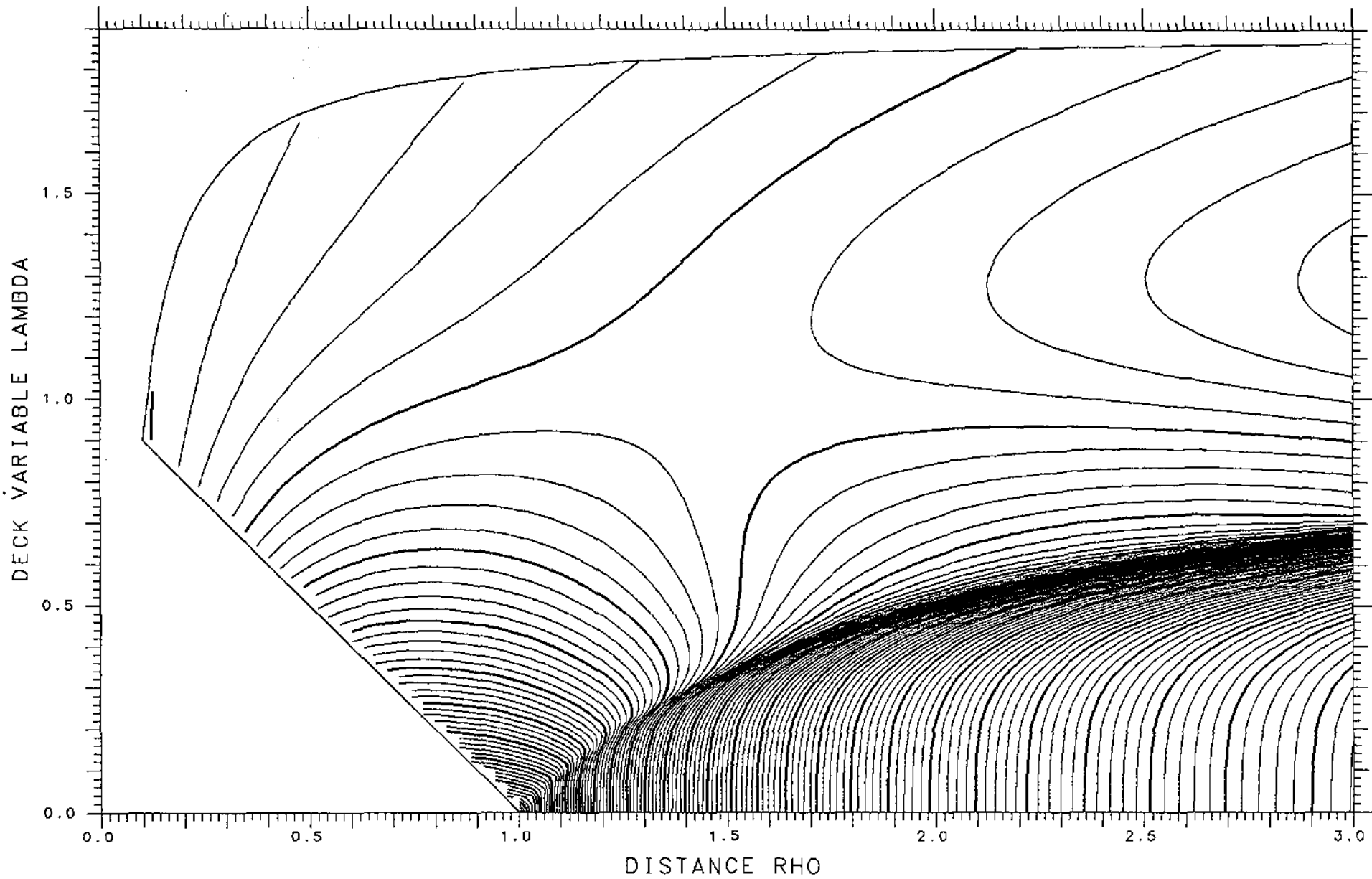

X= .700 ASYMMETRY DELTA= .475 FRACTIONAL= .9569

SPHERES .00225 TANGENT .07435 LENGTH 9.701 ENERGY 583.53 SPACING .002

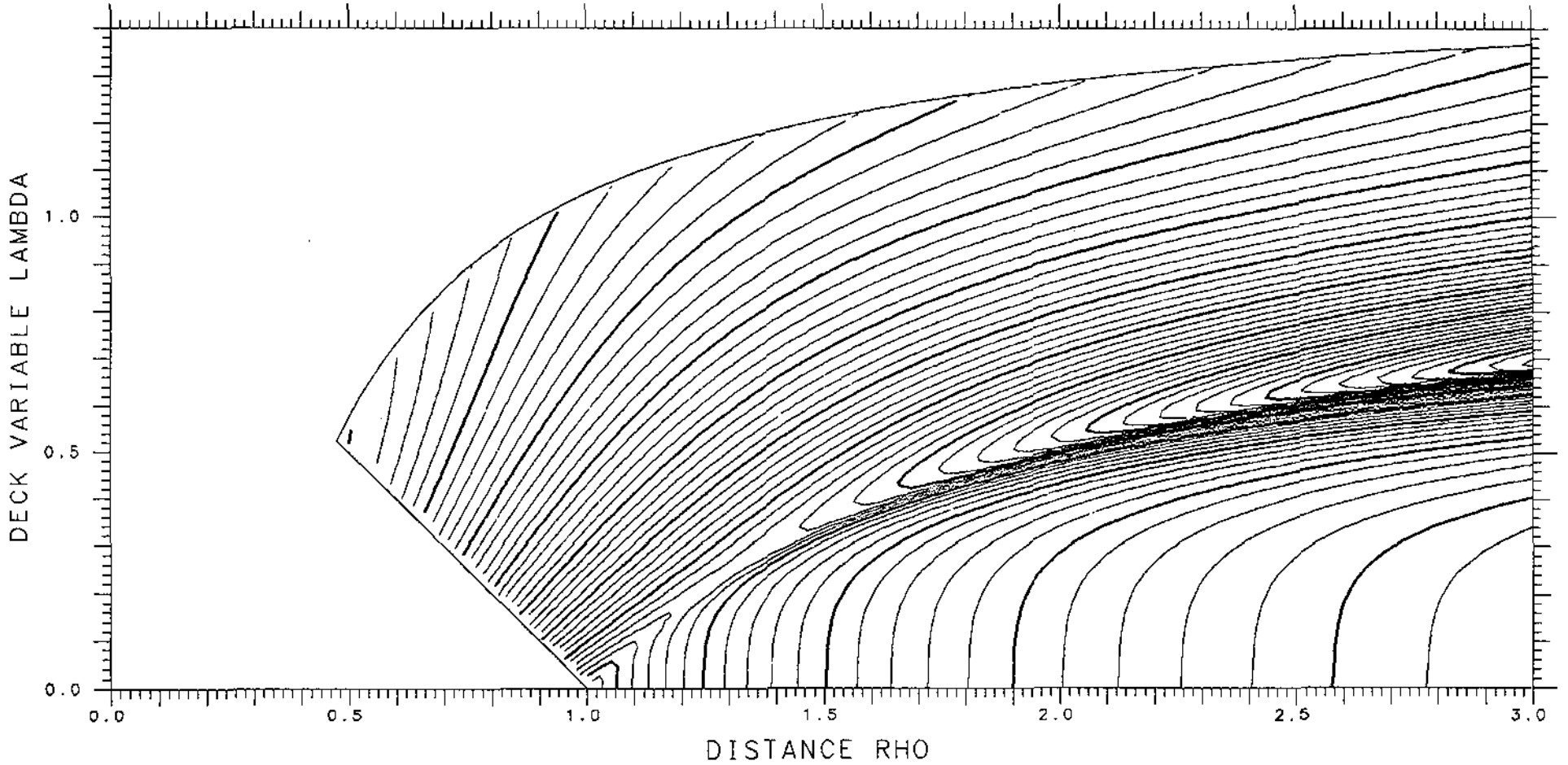

X= .775 ASYMMETRY DELTA= .075 FRACTIONAL= .6108

SPHERES -.29390 TANGENT .09512 LENGTH 11.940 ENERGY 627.05 SPACING .002 SADDLE .01061

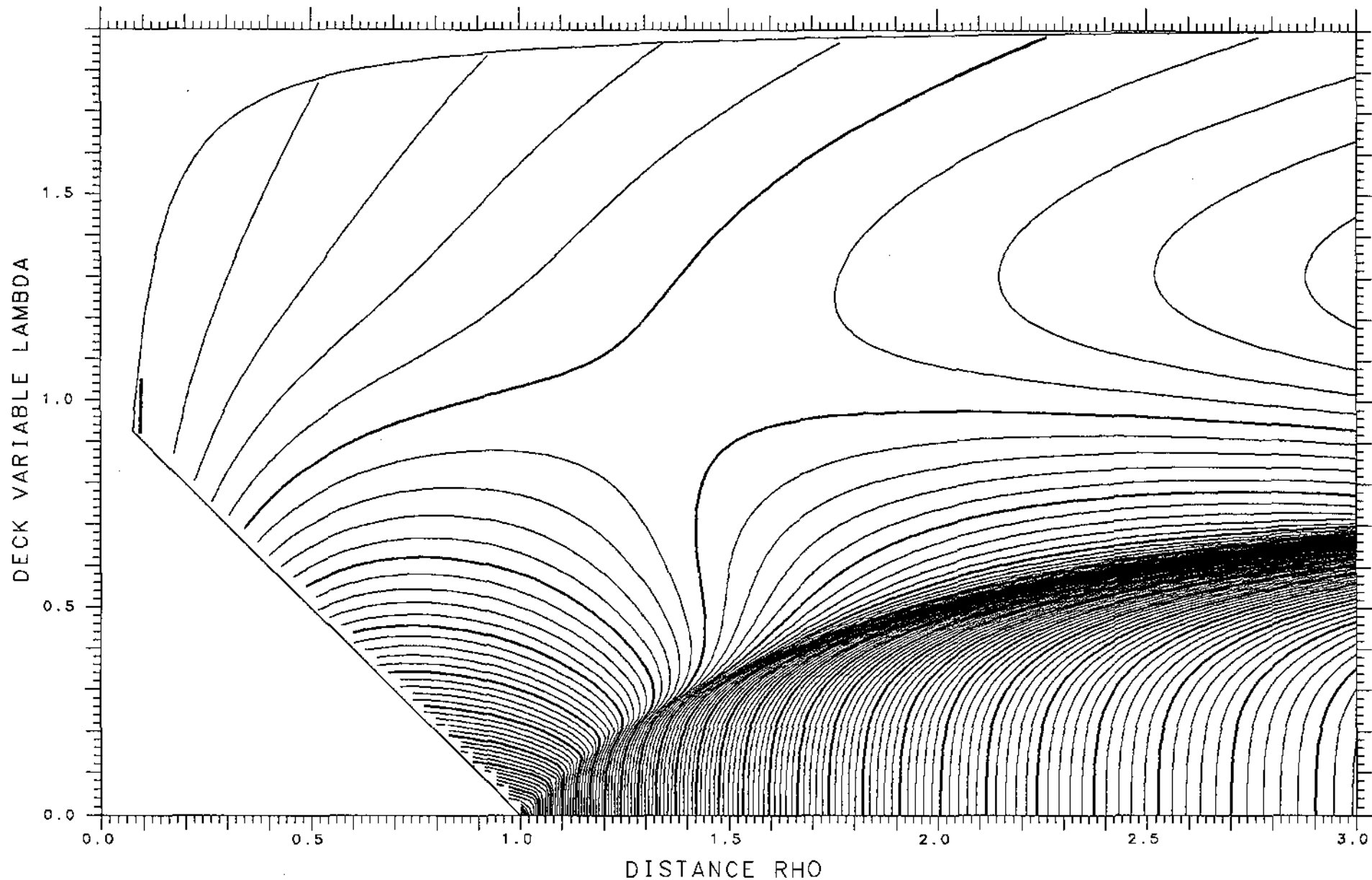

X= .700 ASYMMETRY DELTA= .500 FRACTIONAL= .9643

SPHERES .00758 TANGENT .06858 LENGTH 9.564 ENERGY 583.53 SPACING .002

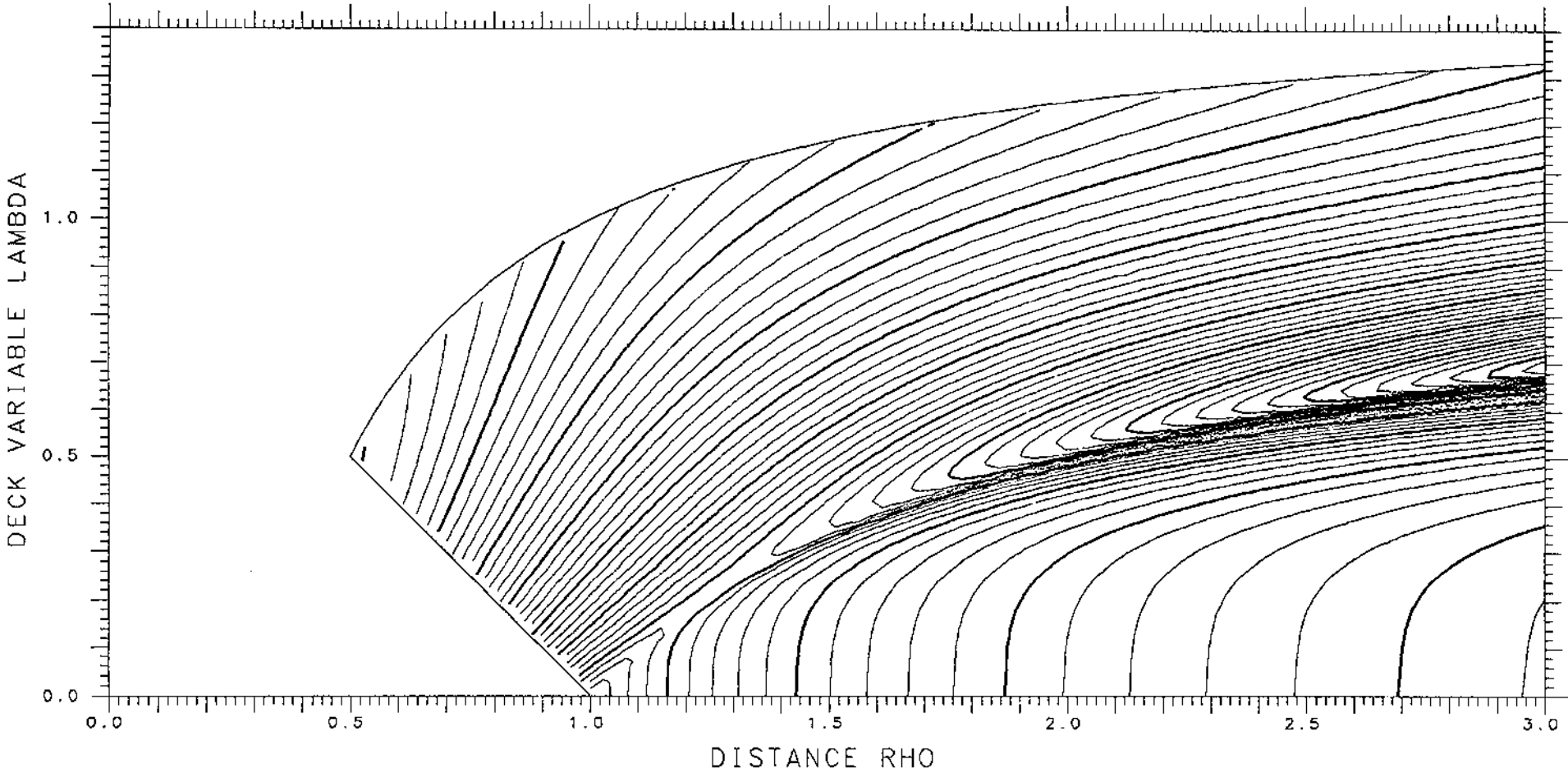

X= .775 ASYMMETRY DELTA= .050 FRACTIONAL= .5745

SPHERES - .3047 TANGENT .09410 LENGTH 11.977 ENERGY 627.05 SPACING .002 SADDLE .01010

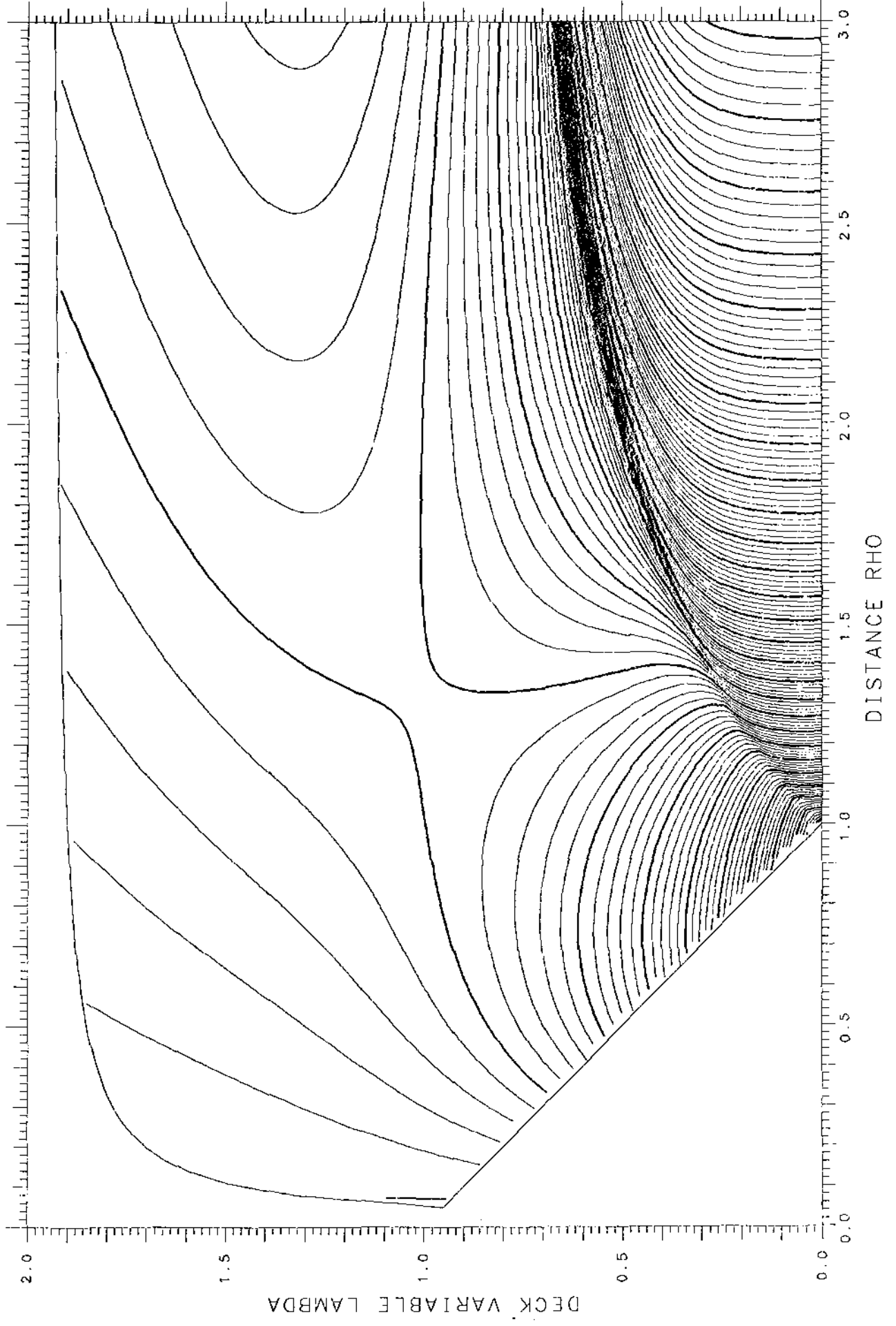

X= .700 ASYMMETRY DELTA= .525 FRACTIONAL= .9707

SPHERES .01159 TANGENT .06276 LENGTH 9.427 ENERGY 583.53 SPACING .002

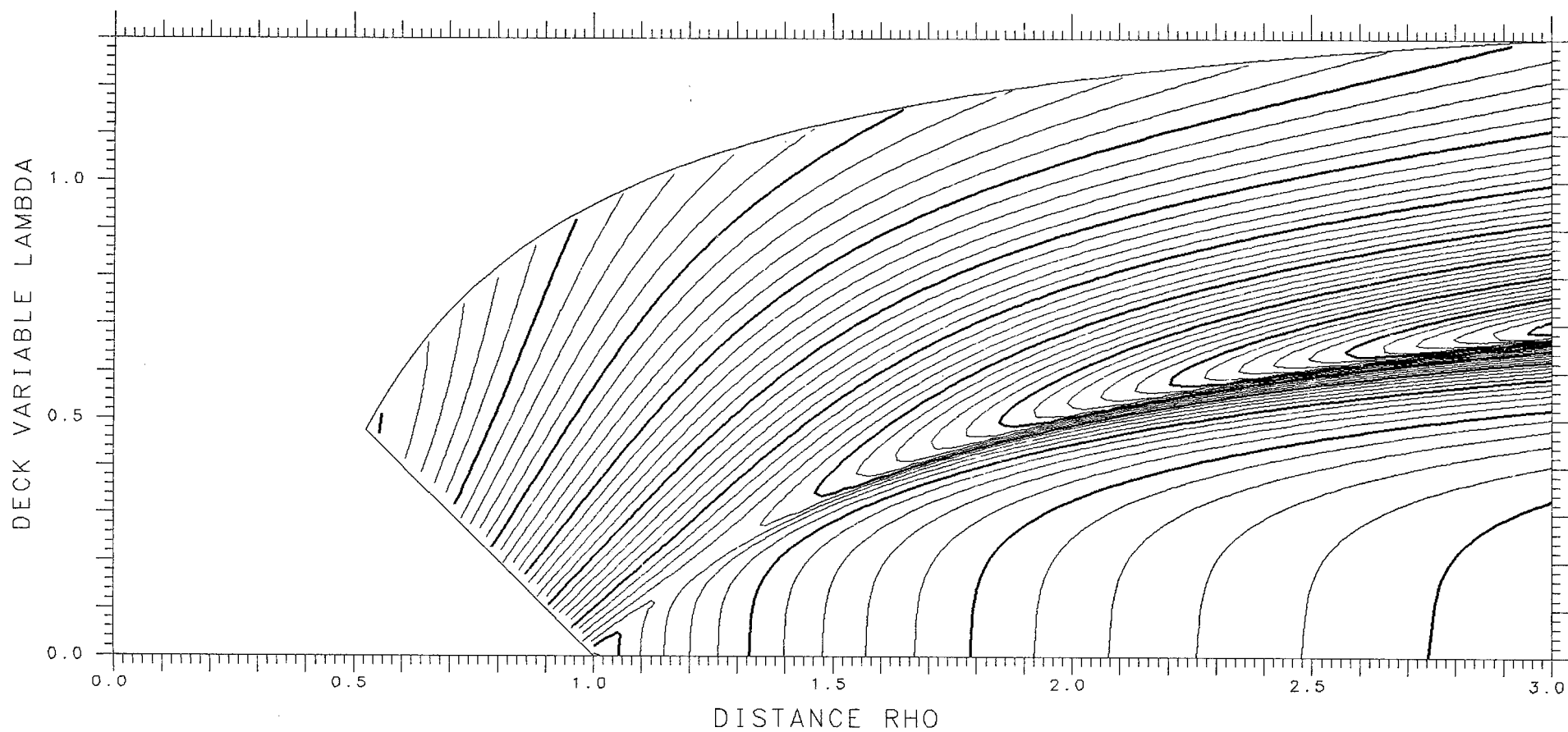

X= .775 ASYMMETRY DELTA= .025 FRACTIONAL= .5374

SPHERES -.31138 TANGENT .09344 LENGTH 11.999 ENERGY 627.05 SPACING .002 SADDLE .00980

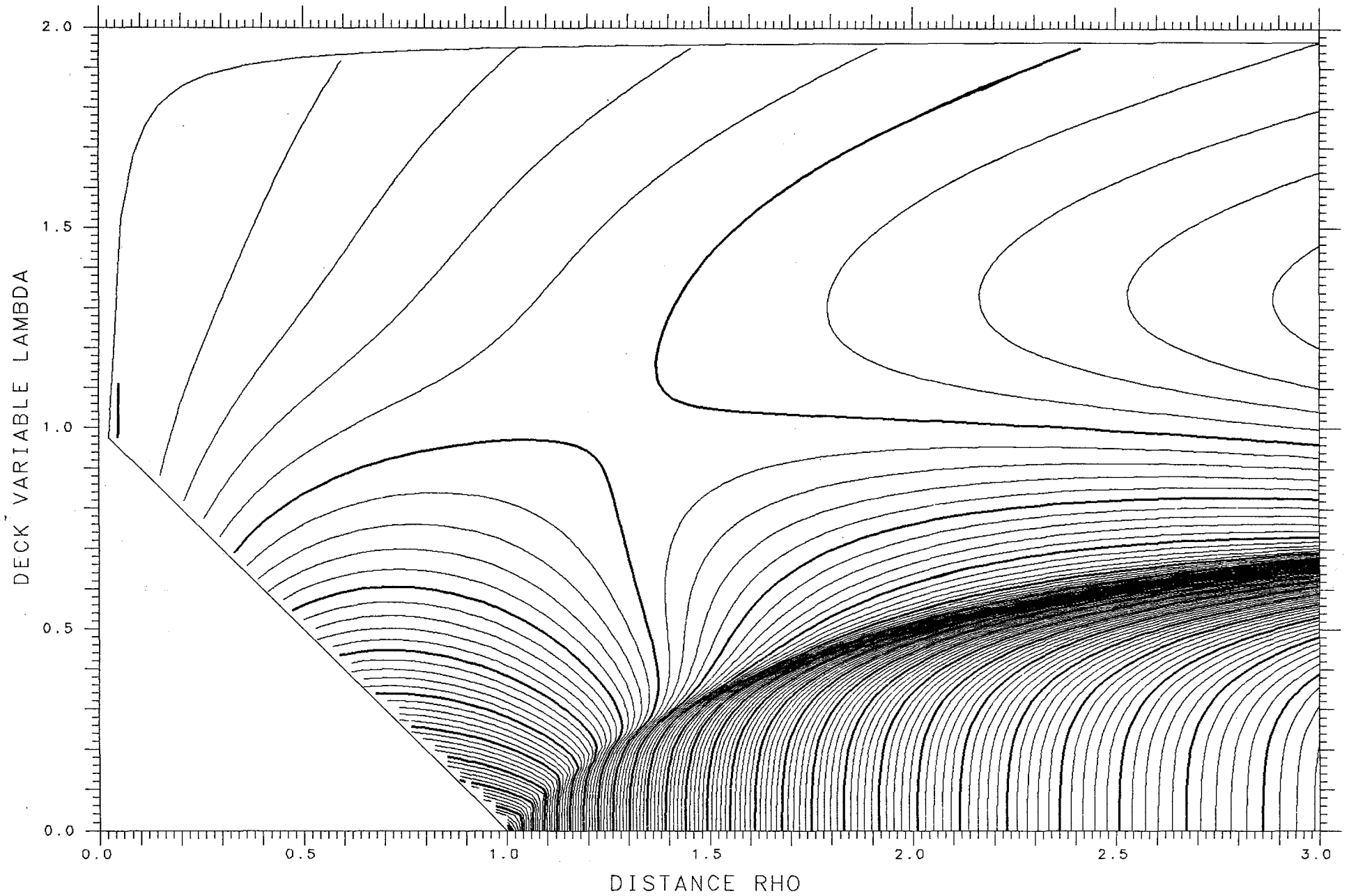

X= .700 ASYMMETRY DELTA= .550 FRACTIONAL= .9761

SPHERES .01444 TANGENT .05694 LENGTH 9.293 ENERGY 583.53 SPACING .002

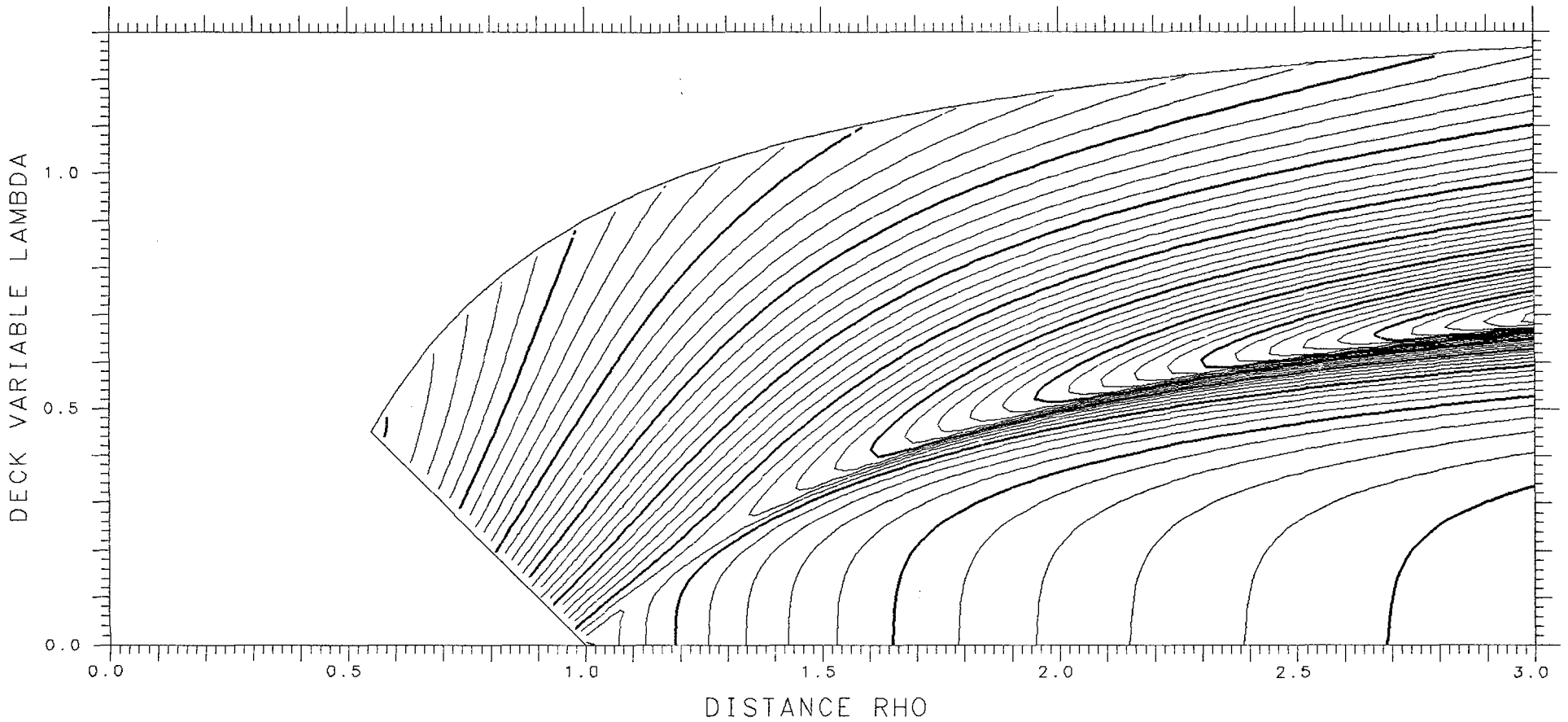

X= .775

ASYMMETRY DELTA=0.

FRACTIONAL= .5000

SPHERES -.31364

TANGENT .09321

LENGTH 12.006

ENERGY 627.05

SPACING .002

SADDLE .00969

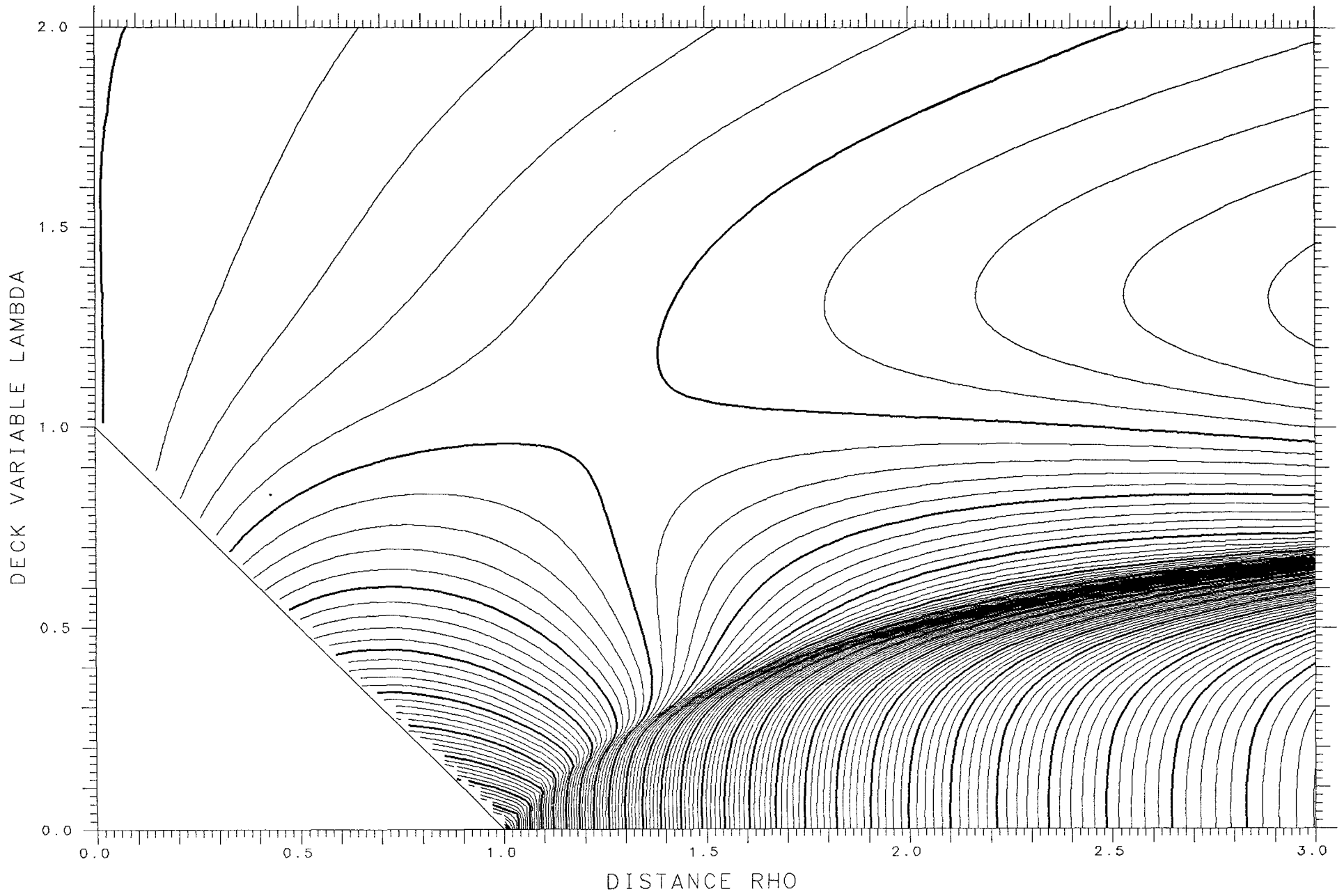

X= .700 ASYMMETRY DELTA= .575 FRACTIONAL= .9807

SPHERES .01625 TANGENT .05121 LENGTH 9.160 ENERGY 583.53 SPACING .002

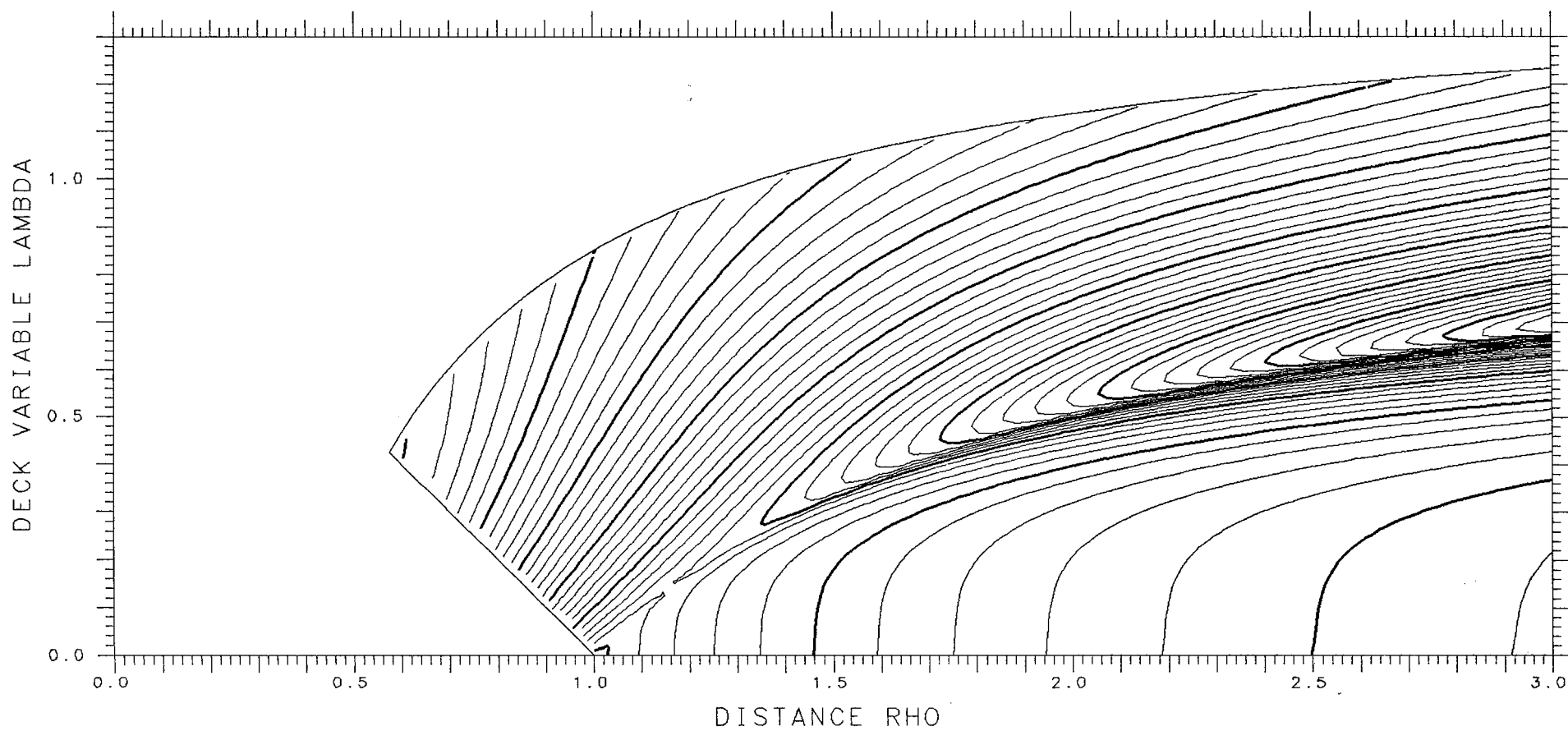

X= .750 ASYMMETRY DELTA= .575 FRACTIONAL= .9807

SPHERES .01320 TANGENT .05065 LENGTH 9.418 ENERGY 612.74 SPACING .002

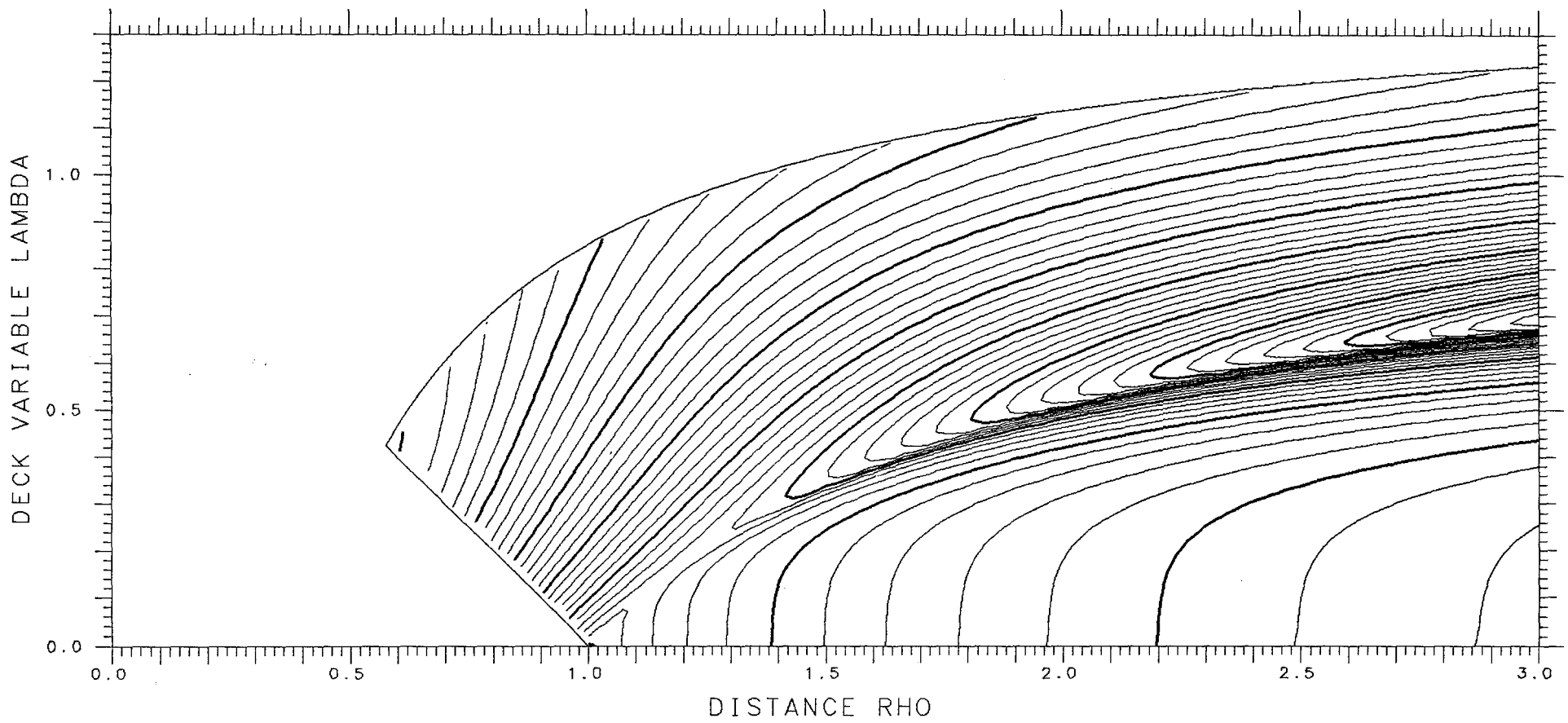

X= .725

ASYMMETRY DELTA=0.

FRACTIONAL= .5000

SPHERES -.27664

TANGENT .10396

LENGTH 11.689

ENERGY 598.24

SPACING .002

SADDLE .01835

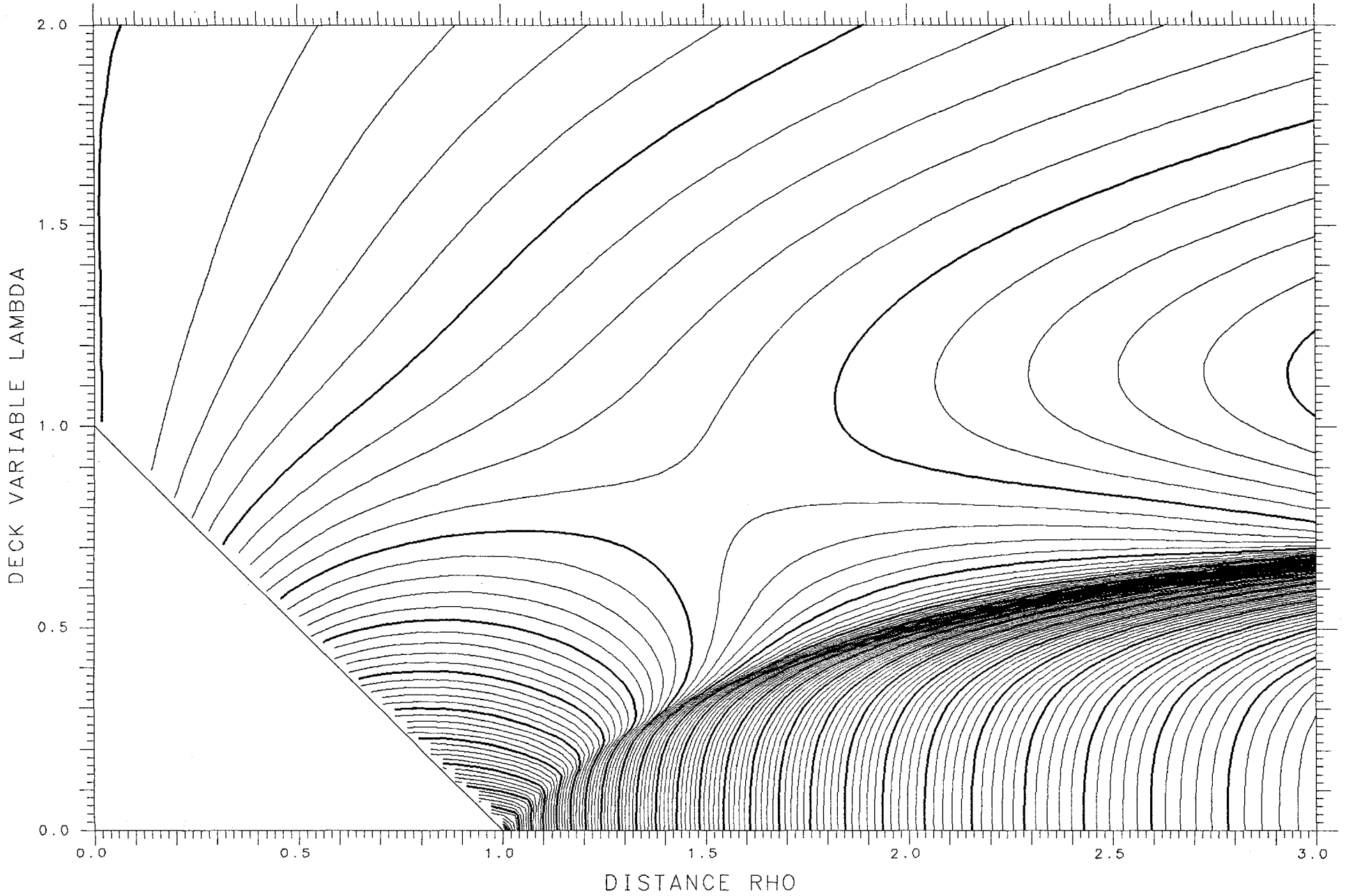

X= .750 ASYMMETRY DELTA= .550 FRACTIONAL= .9761

SPHERES .01068 TANGENT .05622 LENGTH 9.554 ENERGY 612.74 SPACING .002

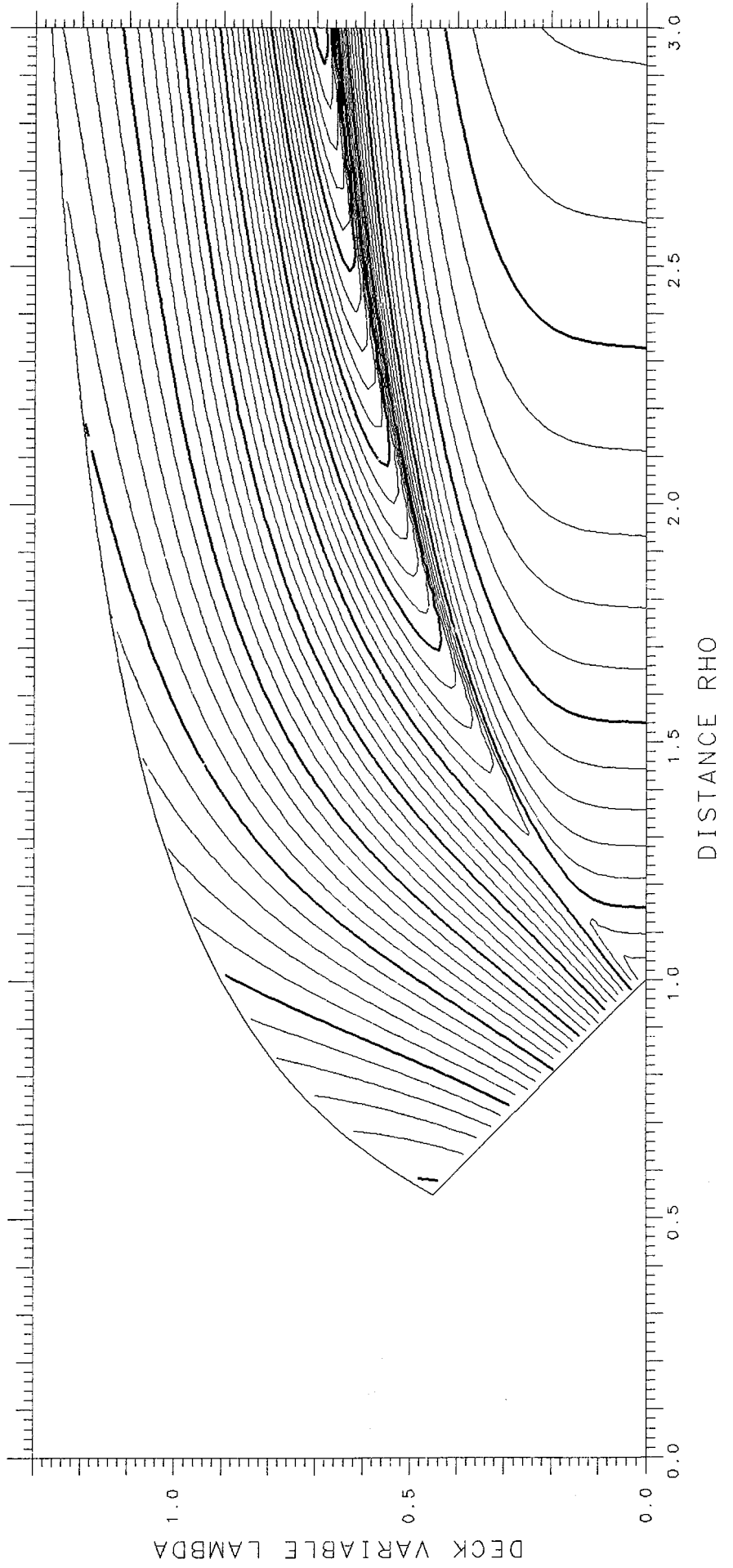

X= .725 ASYMMETRY DELTA= .025 FRACTIONAL= .5374

SPHERES -.27458 TANGENT .10413 LENGTH 11.681 ENERGY 598.24 SPACING .002 SADDLE .01854

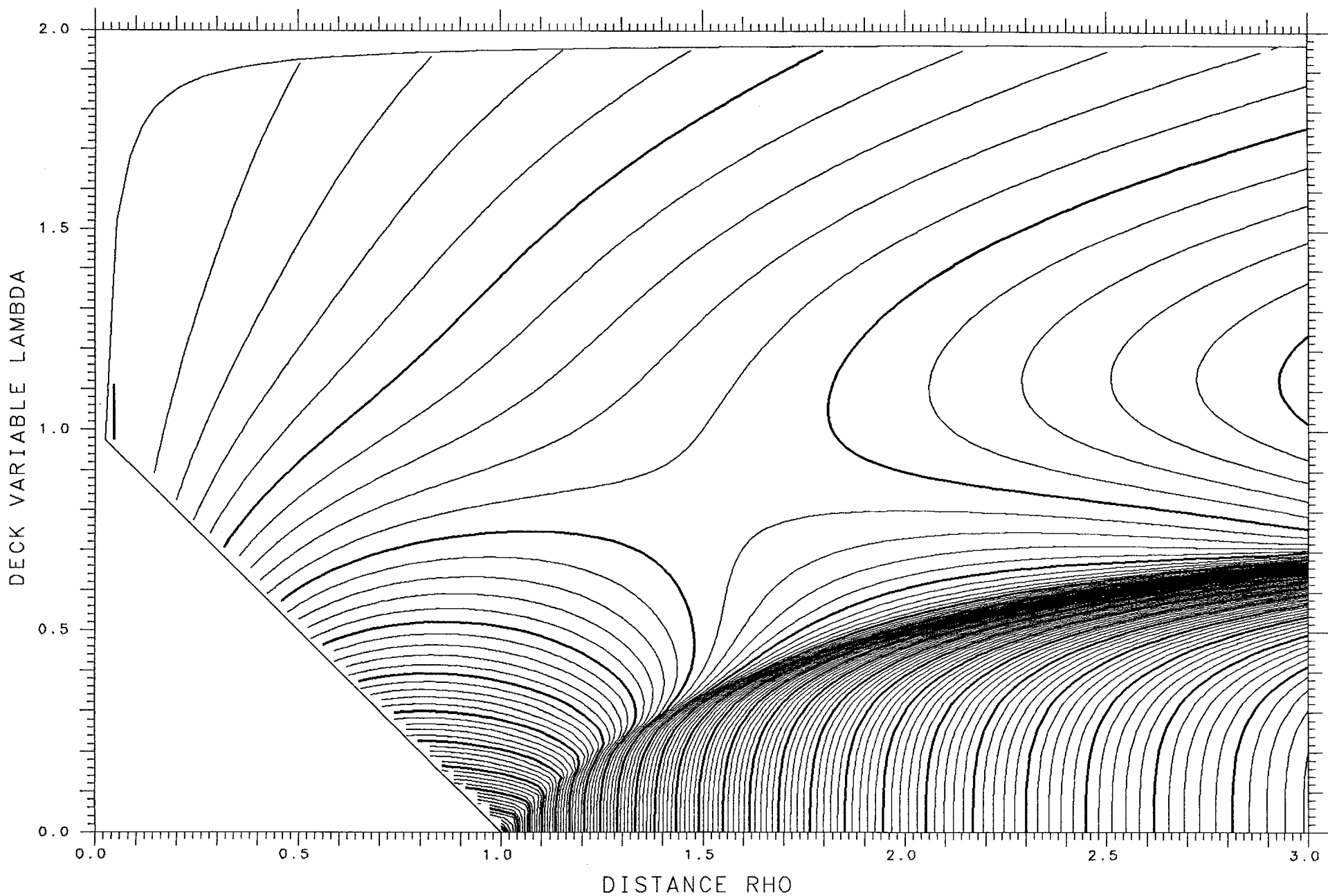

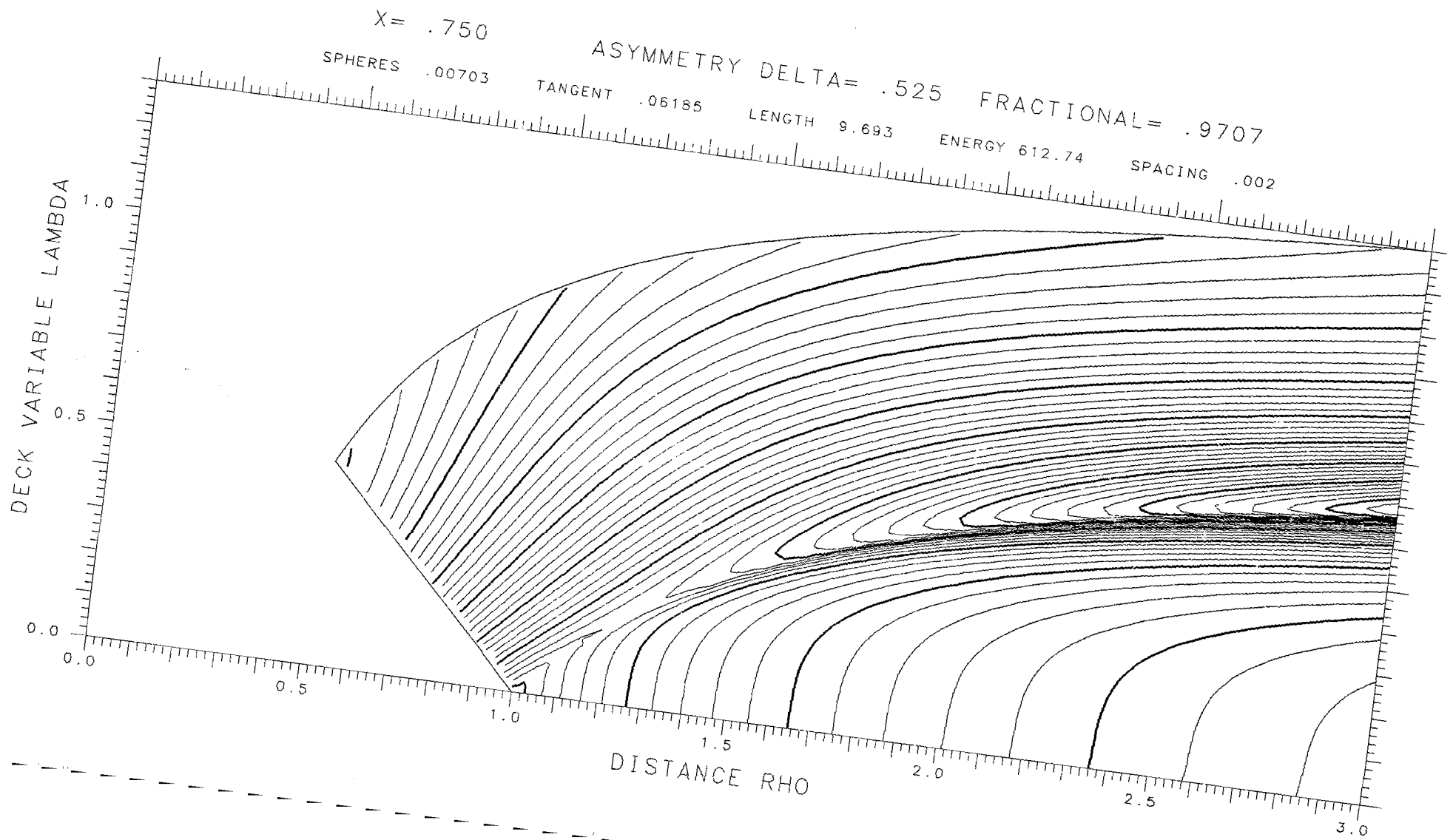

X= .725 ASYMMETRY DELTA= .050 FRACTIONAL= .5745

SPHERES -.26849 TANGENT .10459 LENGTH 11.660 ENERGY 598.24 SPACING .002 SADDLE .01910

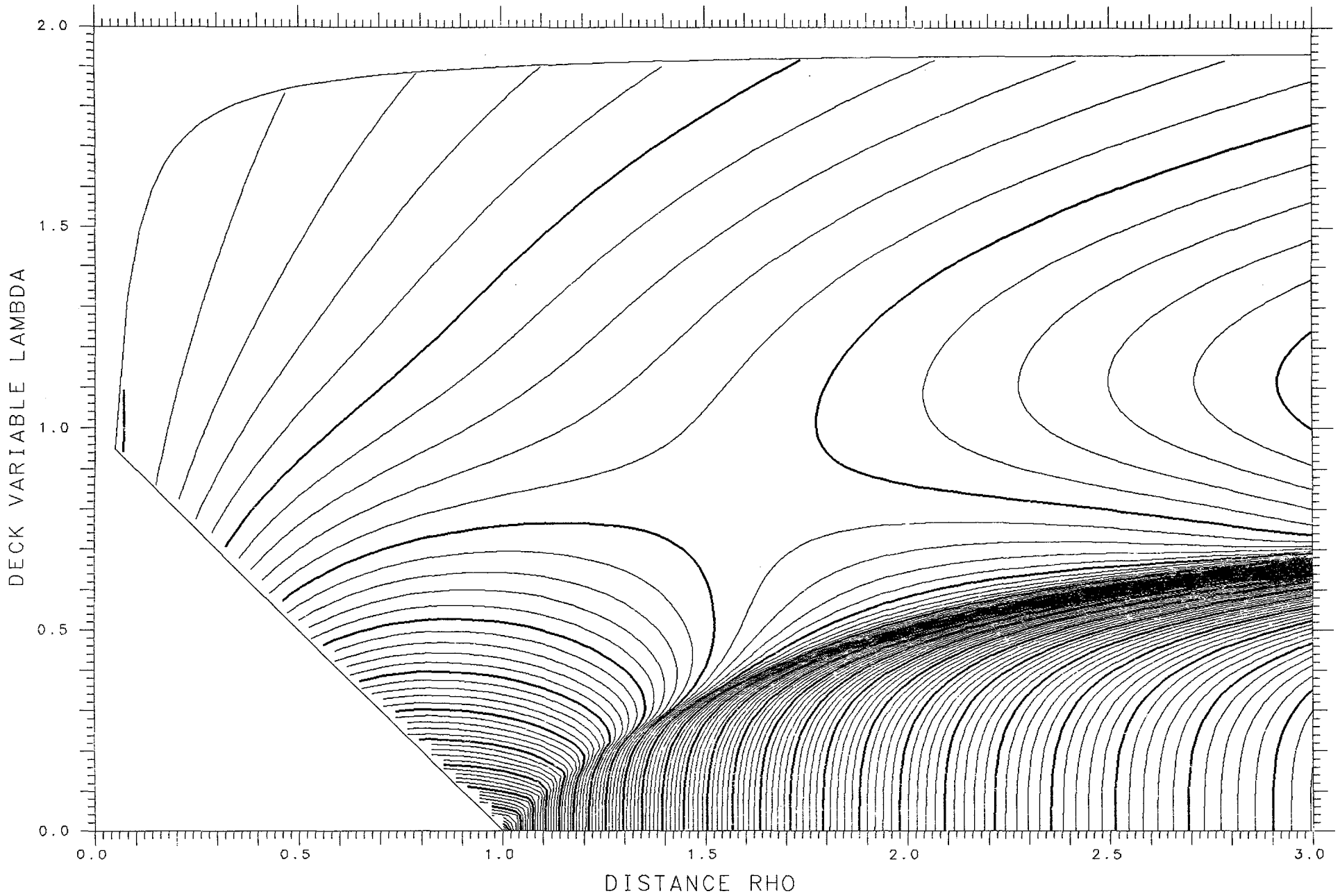

X= .750 ASYMMETRY DELTA= .500 FRACTIONAL= .9643

SPHERES .00209 TANGENT .06745 LENGTH 9.833 ENERGY 612.74 SPACING .002

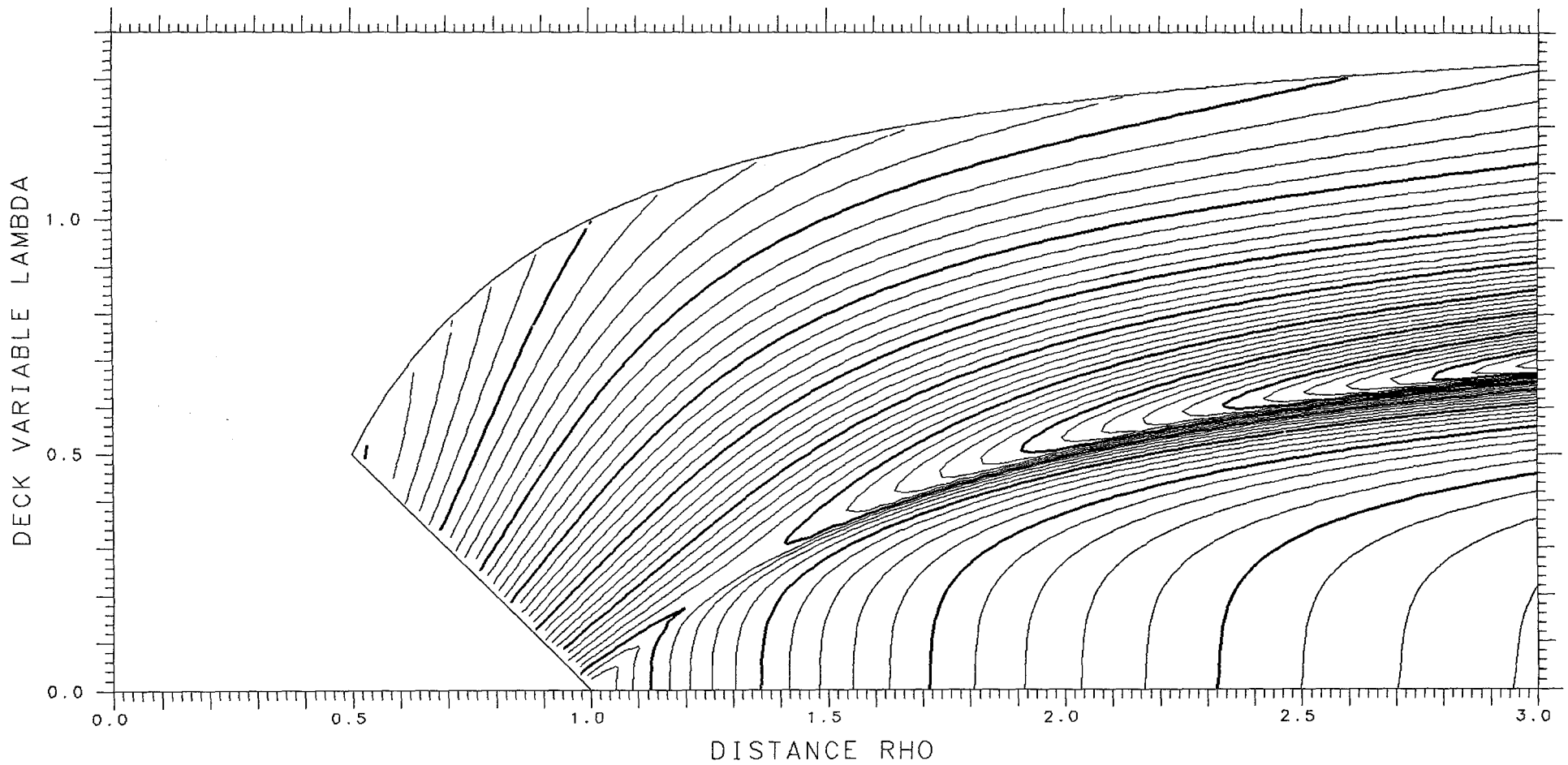

X= .725 ASYMMETRY DELTA= .075 FRACTIONAL= .6108

SPHERES -.25862 TANGENT .10530 LENGTH 11.624 ENERGY 598.24 SPACING .002 SADDLE .02010

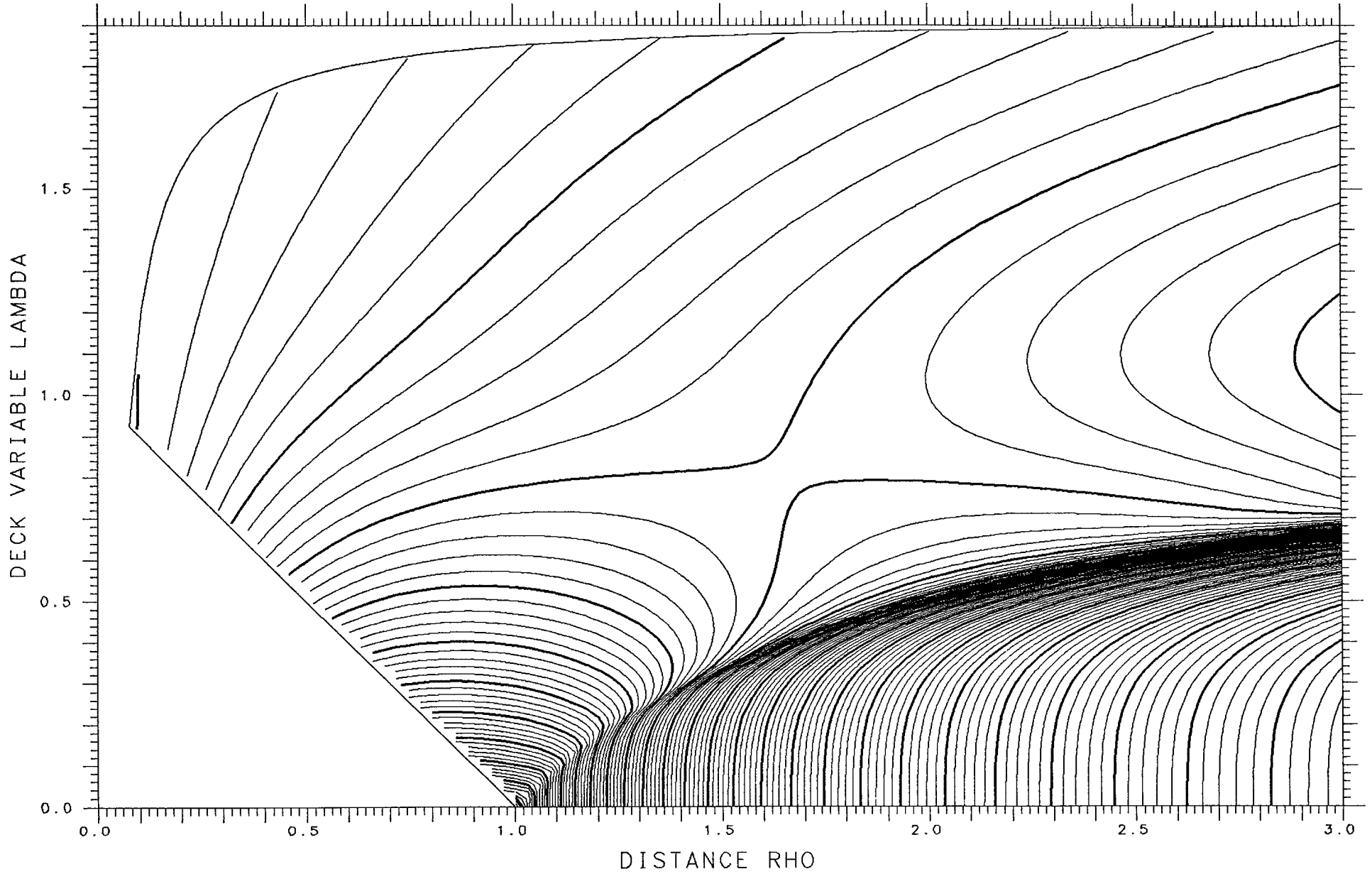

X= .750 ASYMMETRY DELTA= .475 FRACTIONAL= .9569

SPHERES -.00430 TANGENT .07294 LENGTH 9.974 ENERGY 612.74 SPACING .002

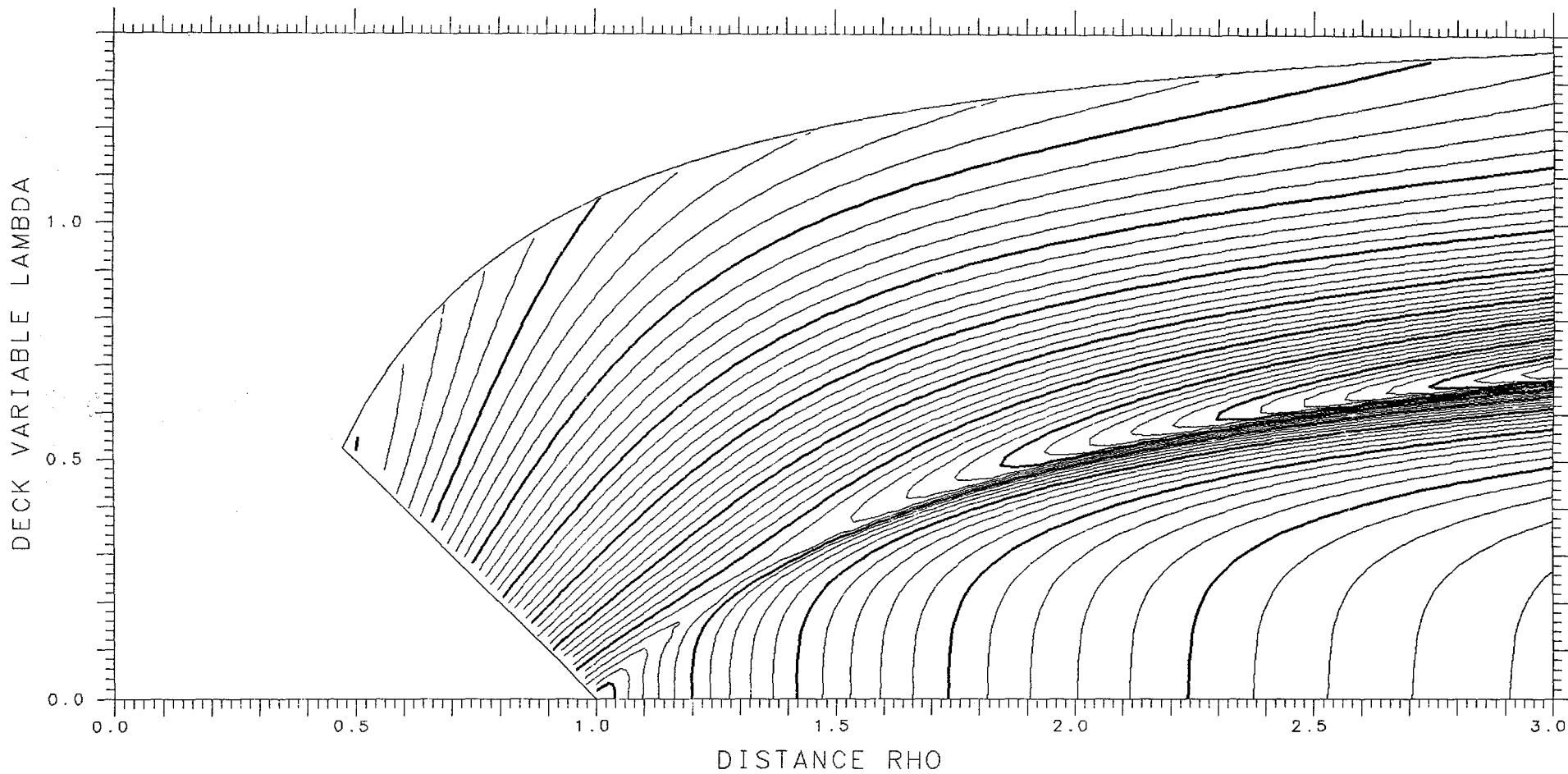

X= .725 ASYMMETRY DELTA= .100 FRACTIONAL= .6461

SPHERES -.24539 TANGENT .10615 LENGTH 11.574 ENERGY 598.24 SPACING .002 SADDLE .02164

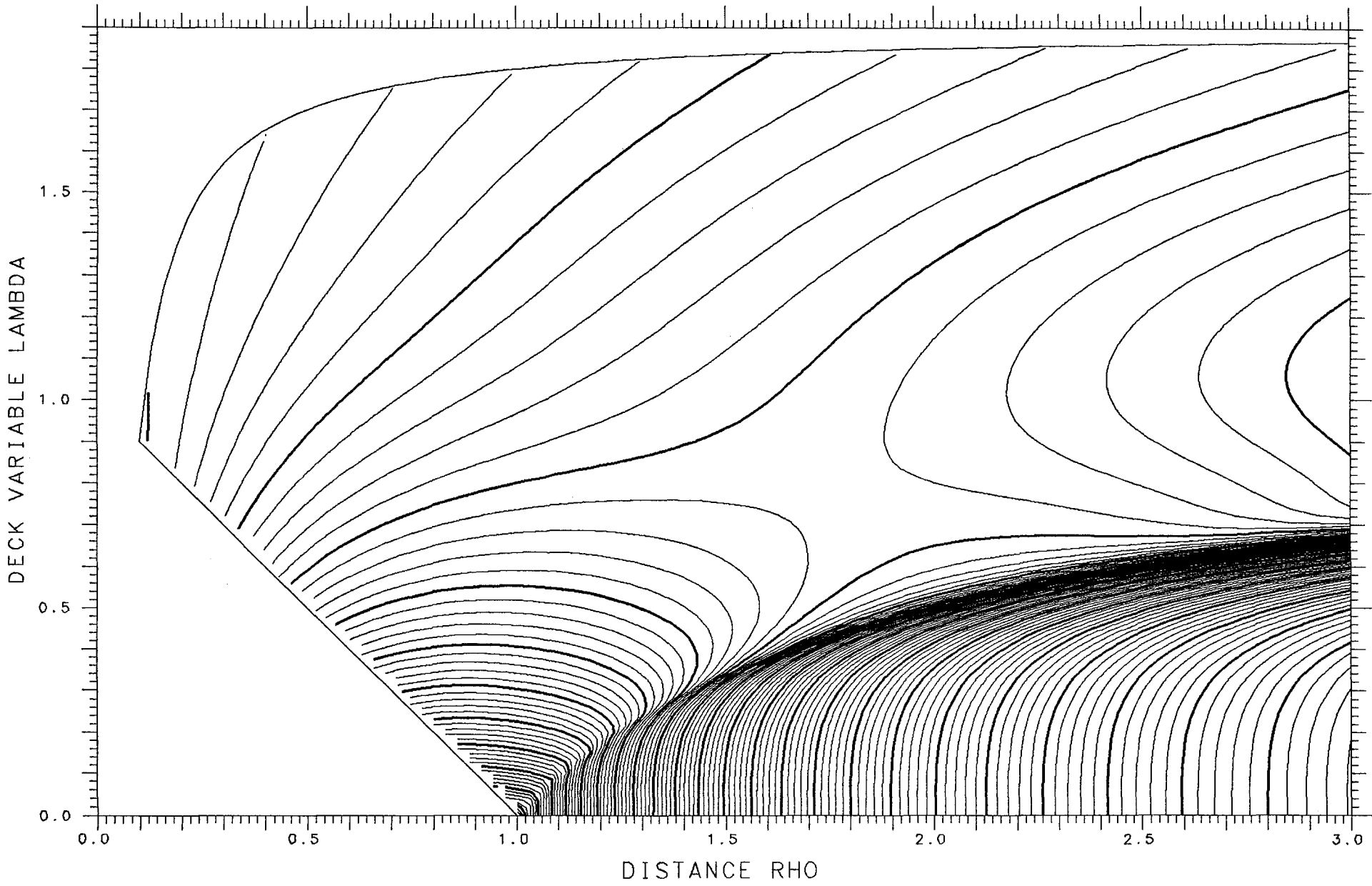

X= .750 ASYMMETRY DELTA= .450 FRACTIONAL= .9483

SPHERES -.01229 TANGENT .07825 LENGTH 10.115 ENERGY 612.74 SPACING .002 SADDLE .06473

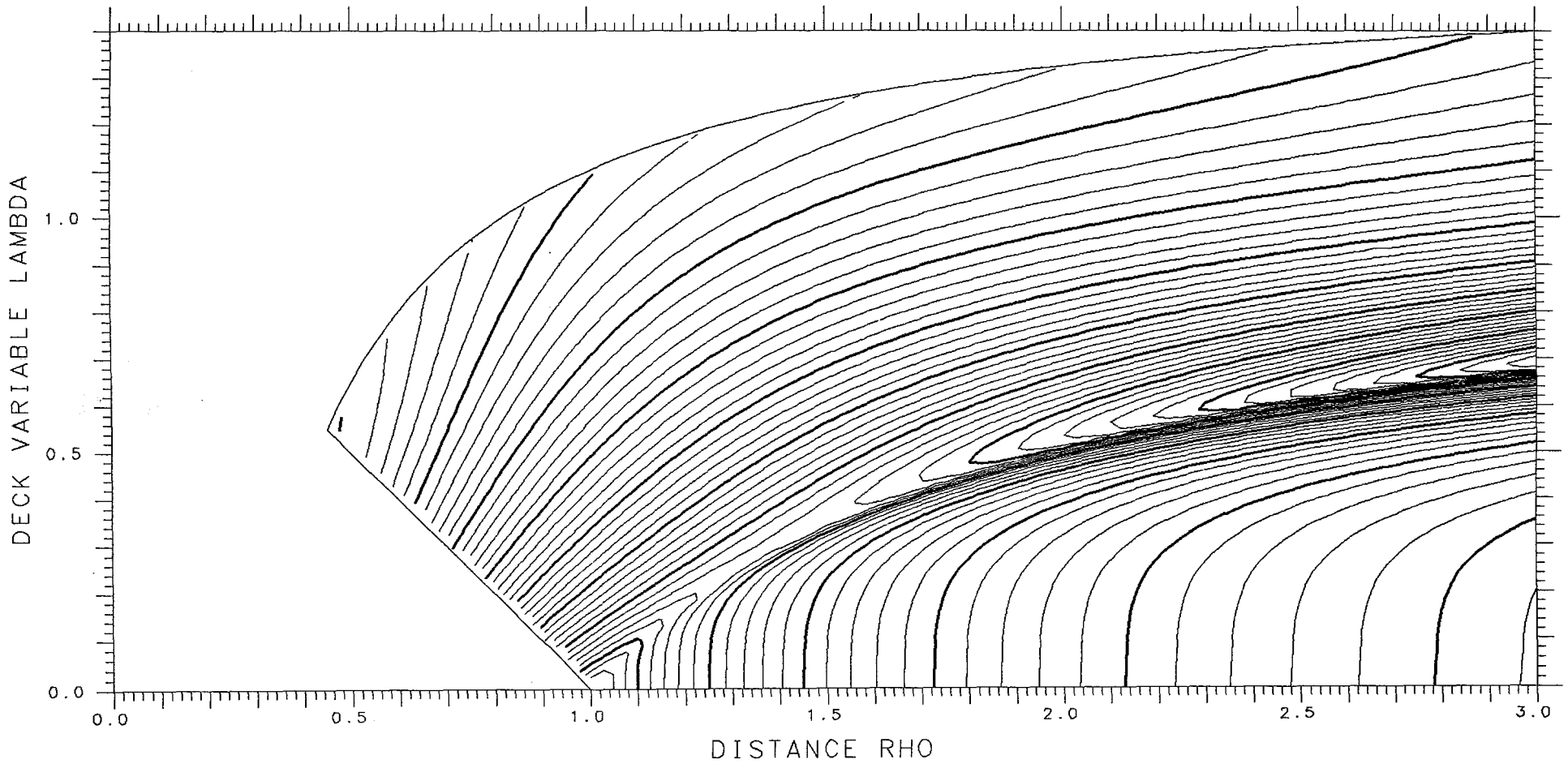

X= .725 ASYMMETRY DELTA= .125 FRACTIONAL= .6800

SPHERES -.22932 TANGENT .10704 LENGTH 11.512 ENERGY 598.24 SPACING .002 SADDLE .02418

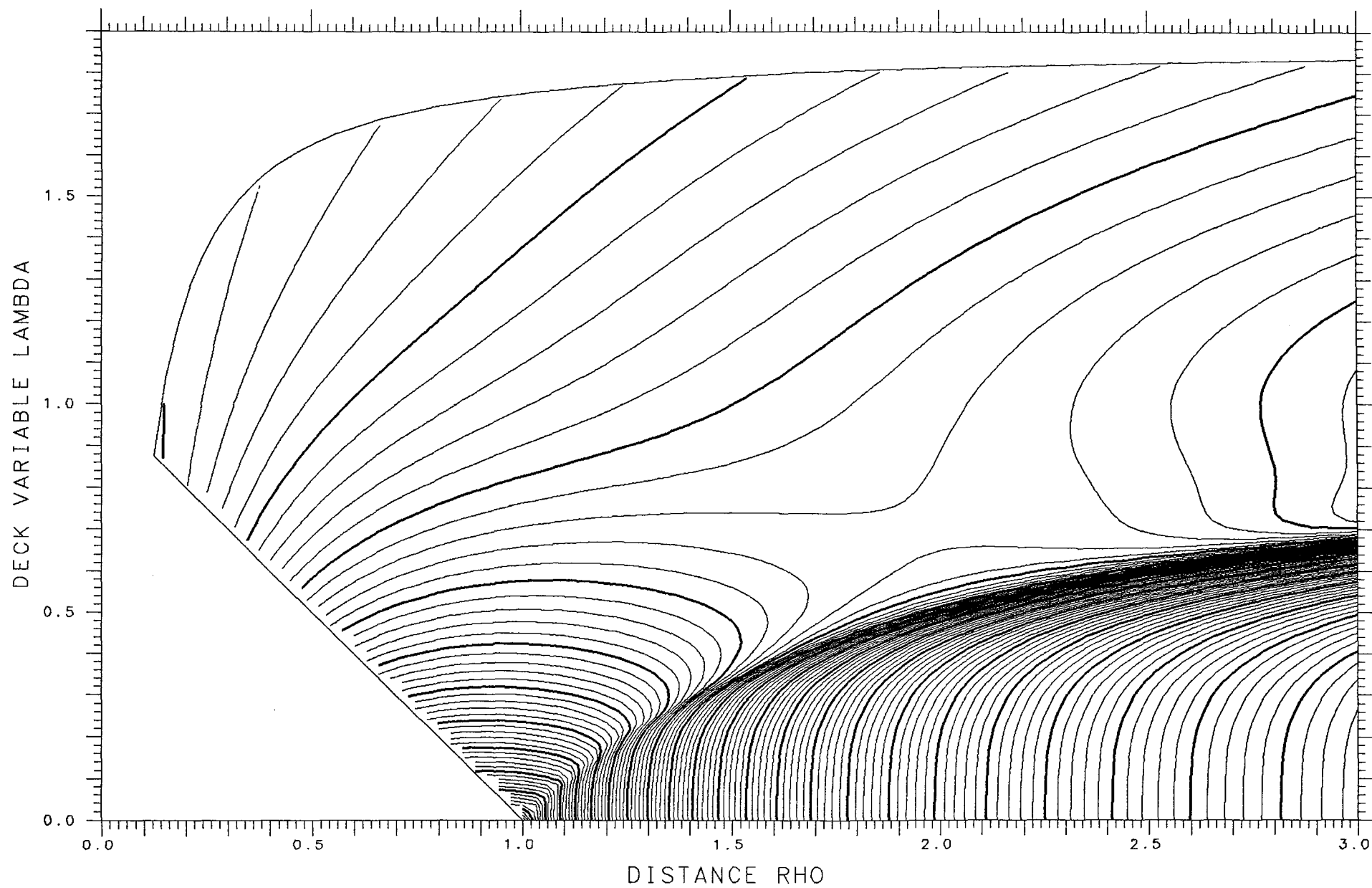

X= .750 ASYMMETRY DELTA= .425 FRACTIONAL= .9384

SPHERES -.02198 TANGENT .08327 LENGTH 10.257 ENERGY 612.74 SPACING .002 SADDLE .06622

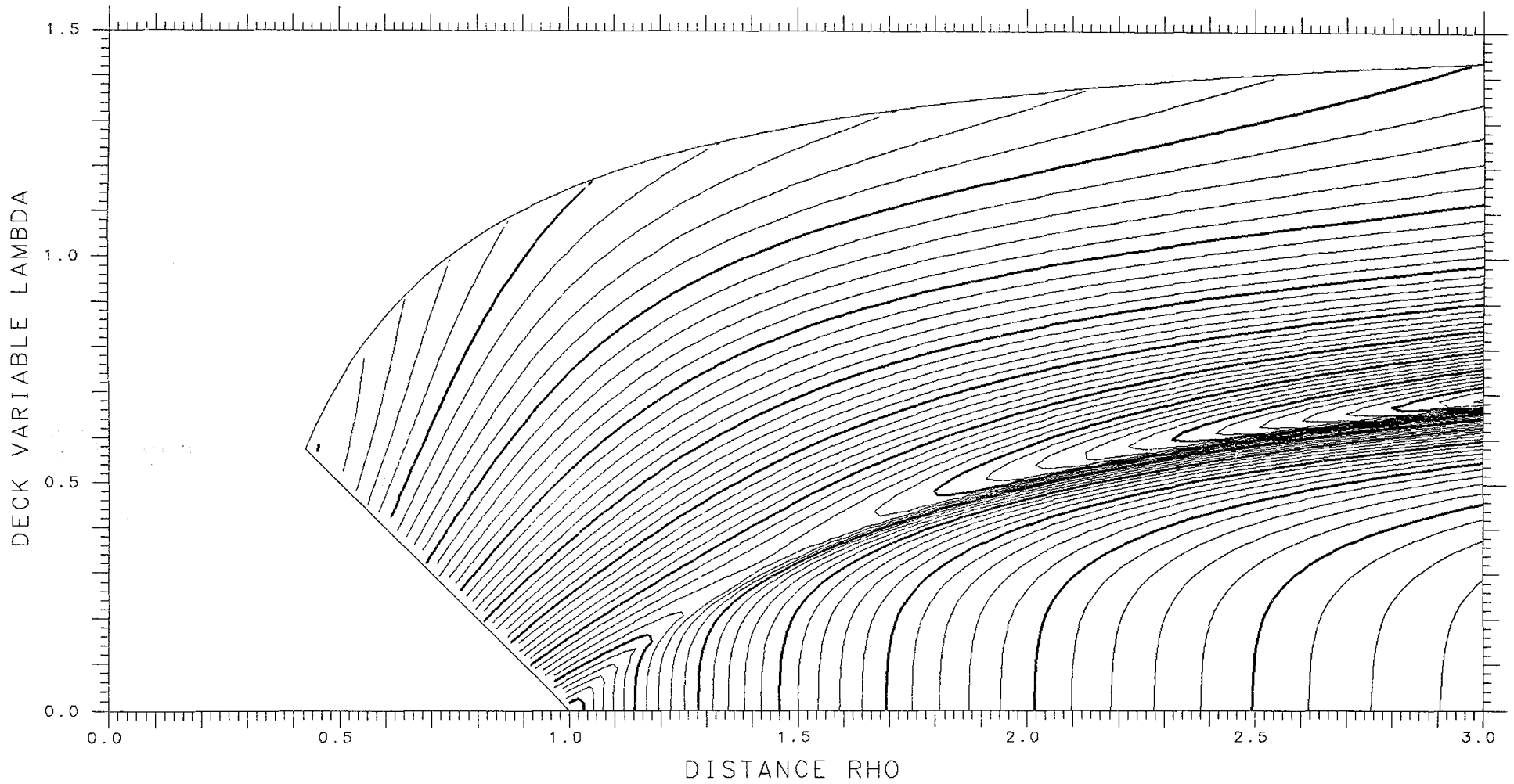

X= .725 ASYMMETRY DELTA= .150 FRACTIONAL= .7124

SPHERES -.21101 TANGENT .10781 LENGTH 11.437 ENERGY 598.24 SPACING .002 SADDLE .02864

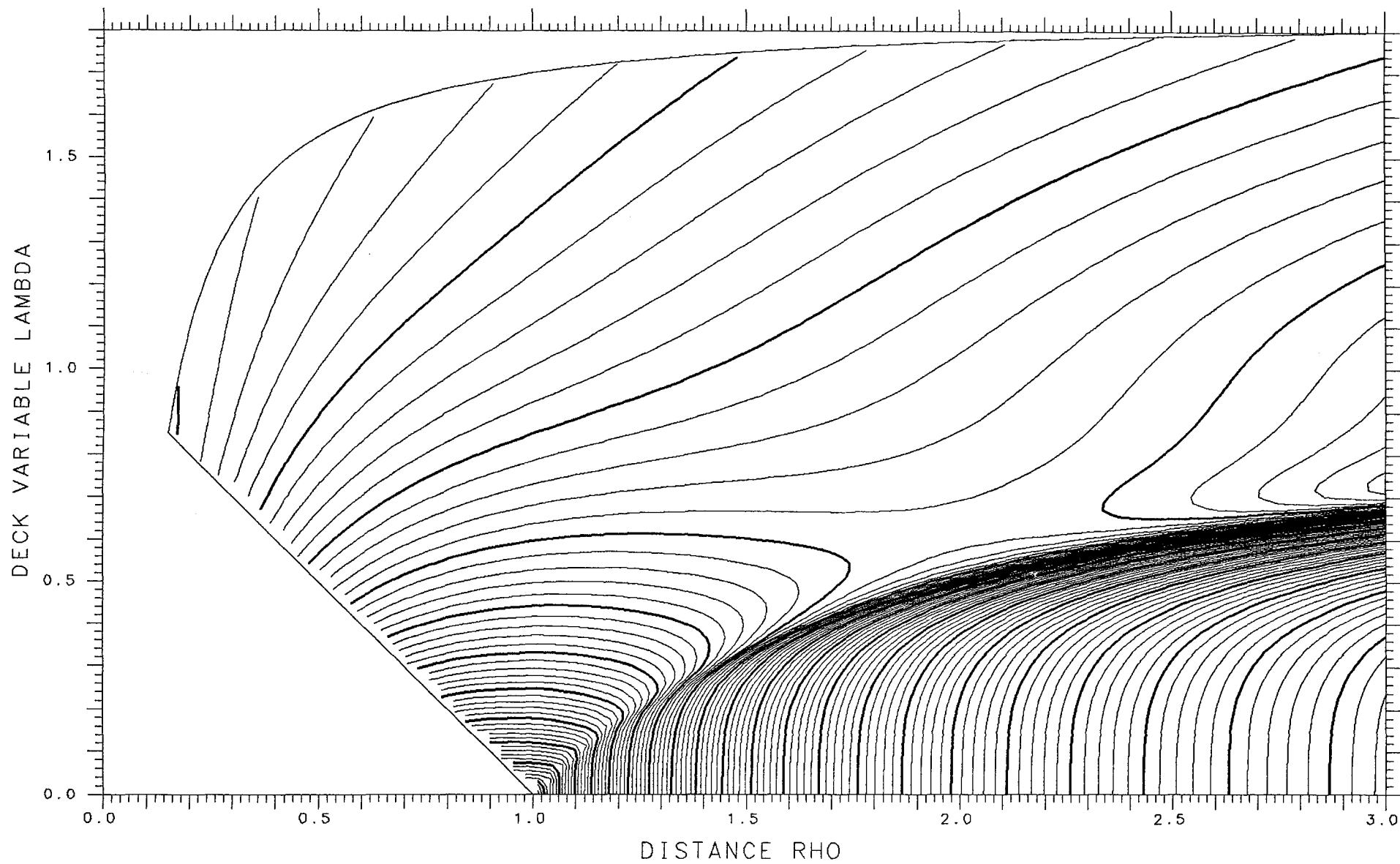

X= .750 ASYMMETRY DELTA= .400 FRACTIONAL= .9270

SPHERES -.03348 TANGENT .08793 LENGTH 10.398 ENERGY 612.74 SPACING .002 SADDLE .06673

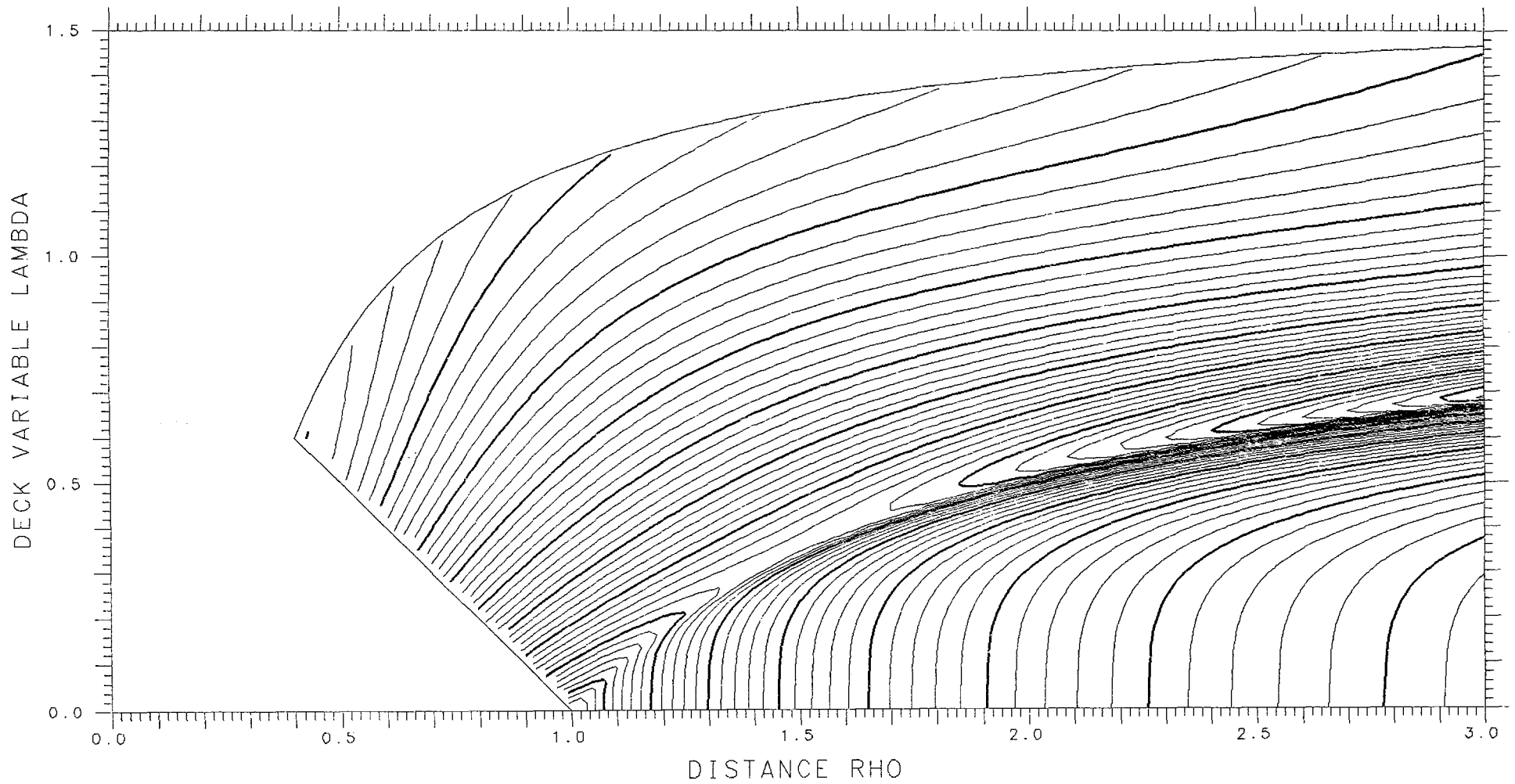

X= .725 ASYMMETRY DELTA= .175 FRACTIONAL= .7429

SPHERES -.19111 TANGENT .10834 LENGTH 11.351 ENERGY 598.24 SPACING .002 SADDLE .03429

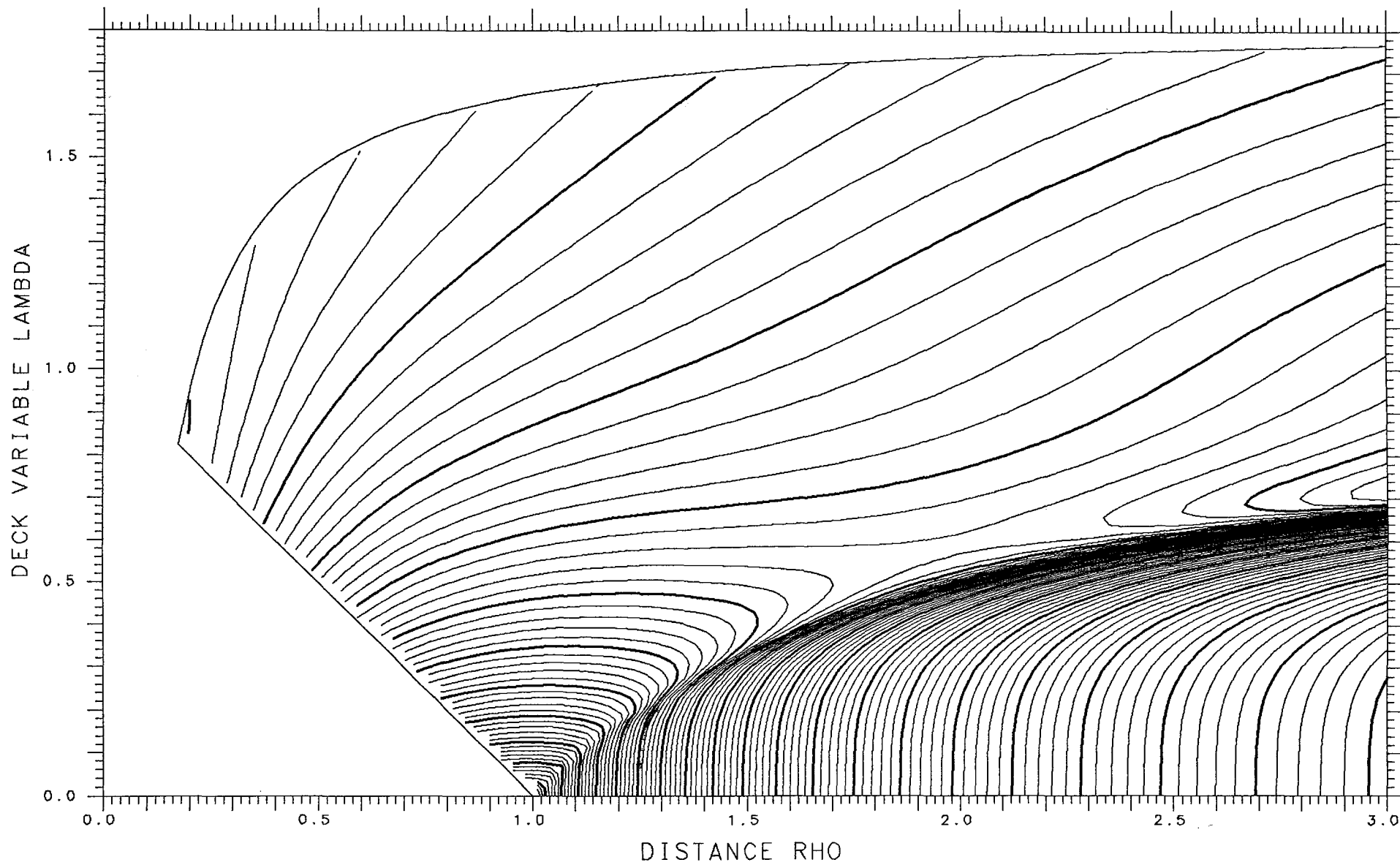

X= .750 ASYMMETRY DELTA= .375 FRACTIONAL= .9141

SPHERES -.04684 TANGENT .09215 LENGTH 10.537 ENERGY 612.74 SPACING .002 SADDLE .06615

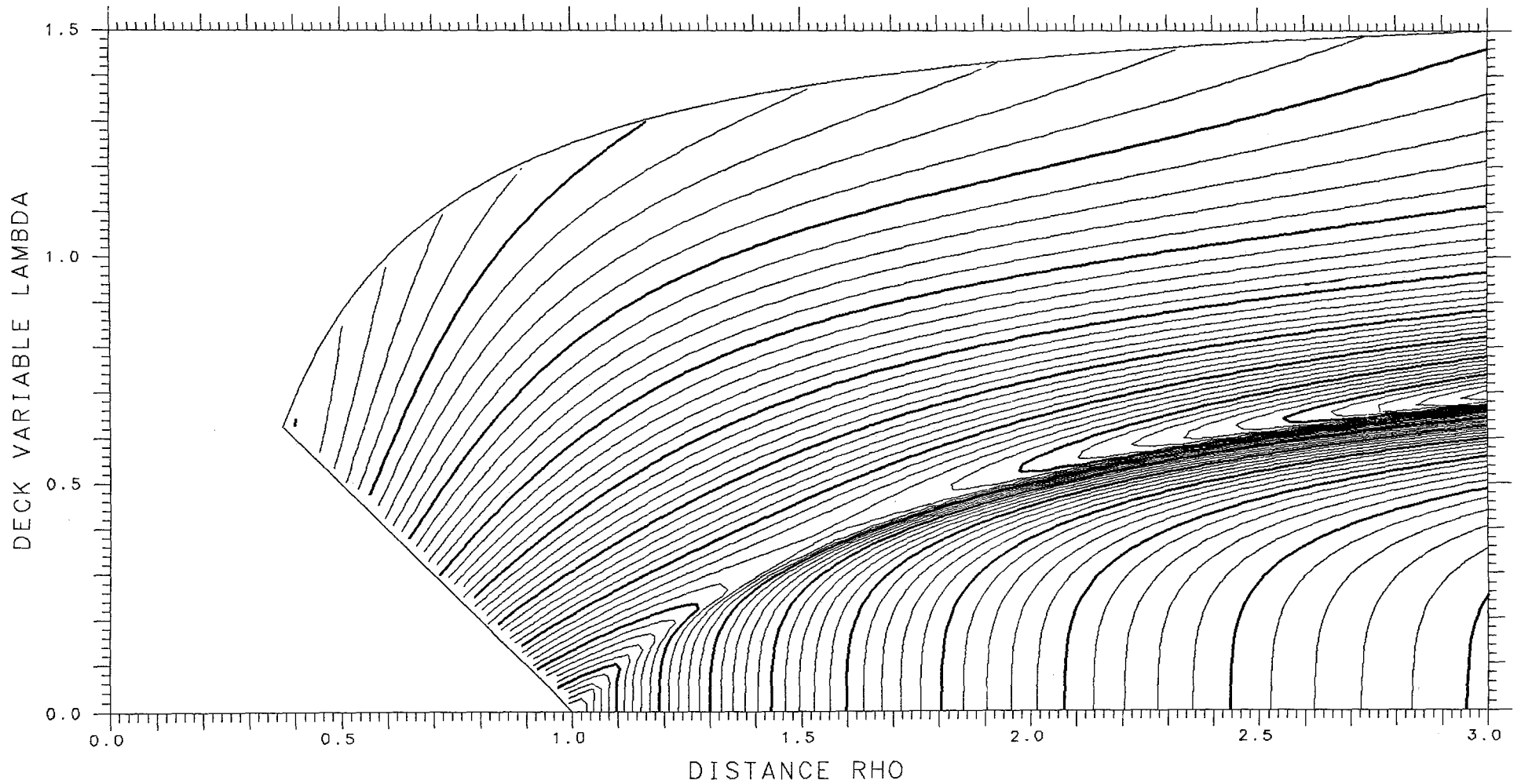

X= .725 ASYMMETRY DELTA= .200 FRACTIONAL= .7714

SPHERES -.17027 TANGENT .10851 LENGTH 11.255 ENERGY 598.24 SPACING .002 SADDLE .04046

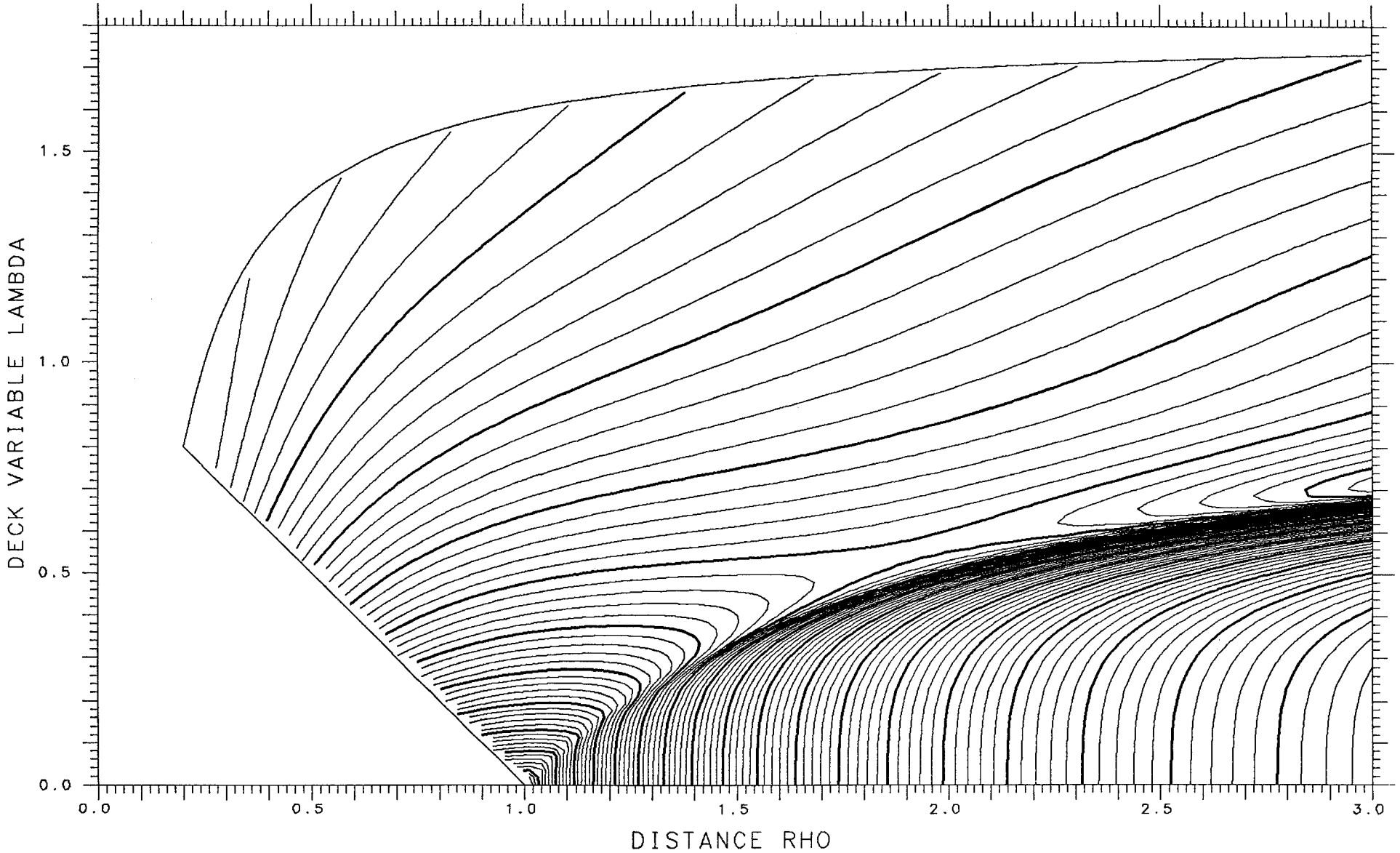

X= .750 ASYMMETRY DELTA= .350 FRACTIONAL= .8996

SPHERES -.06207 TANGENT .09583 LENGTH 10.675 ENERGY 612.74 SPACING .002 SADDLE .06439

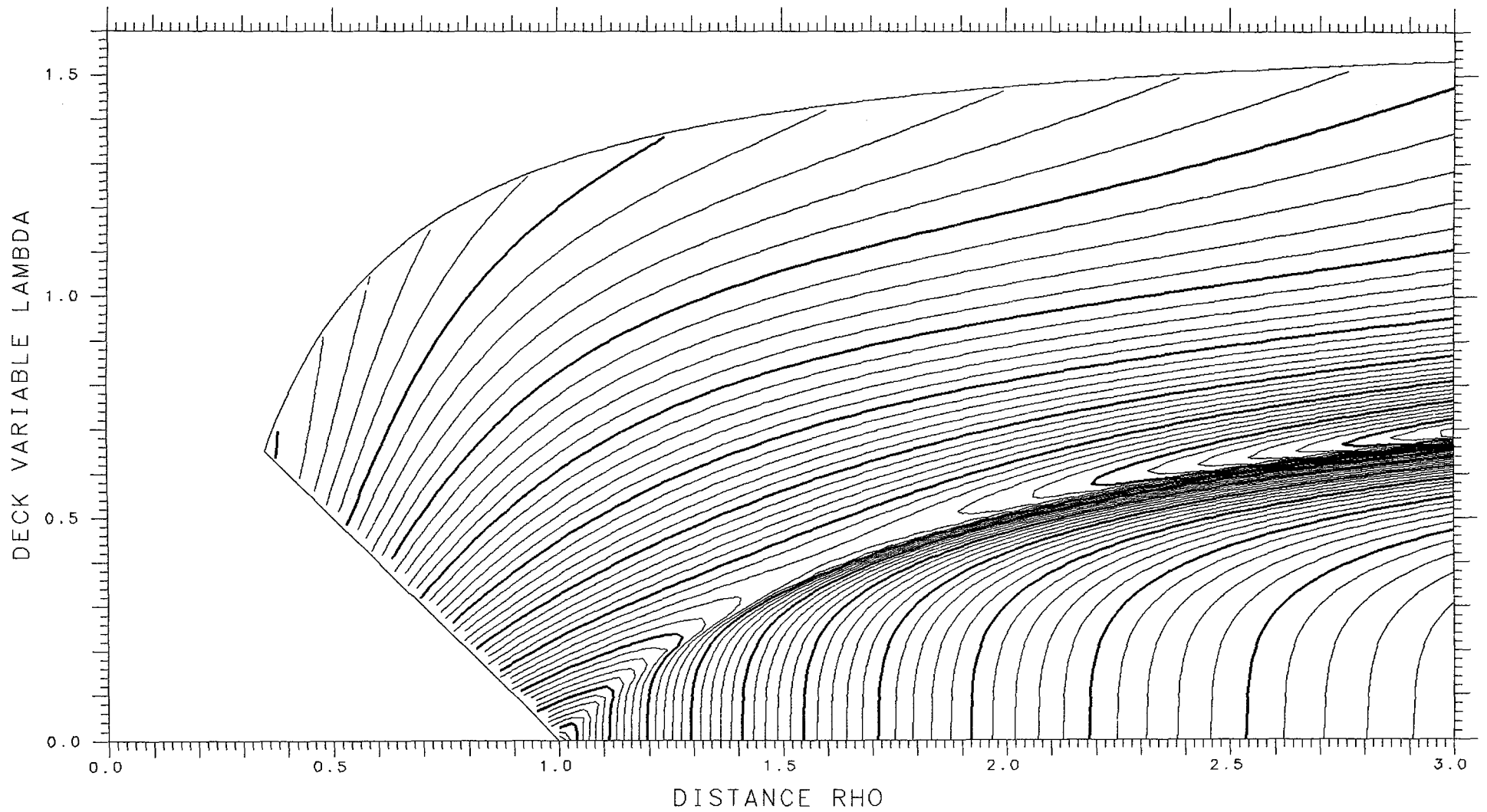

X= .725 ASYMMETRY DELTA= .225 FRACTIONAL= .7979

SPHERES -.14910 TANGENT .10820 LENGTH 11.151 ENERGY 598.24 SPACING .002 SADDLE .04669

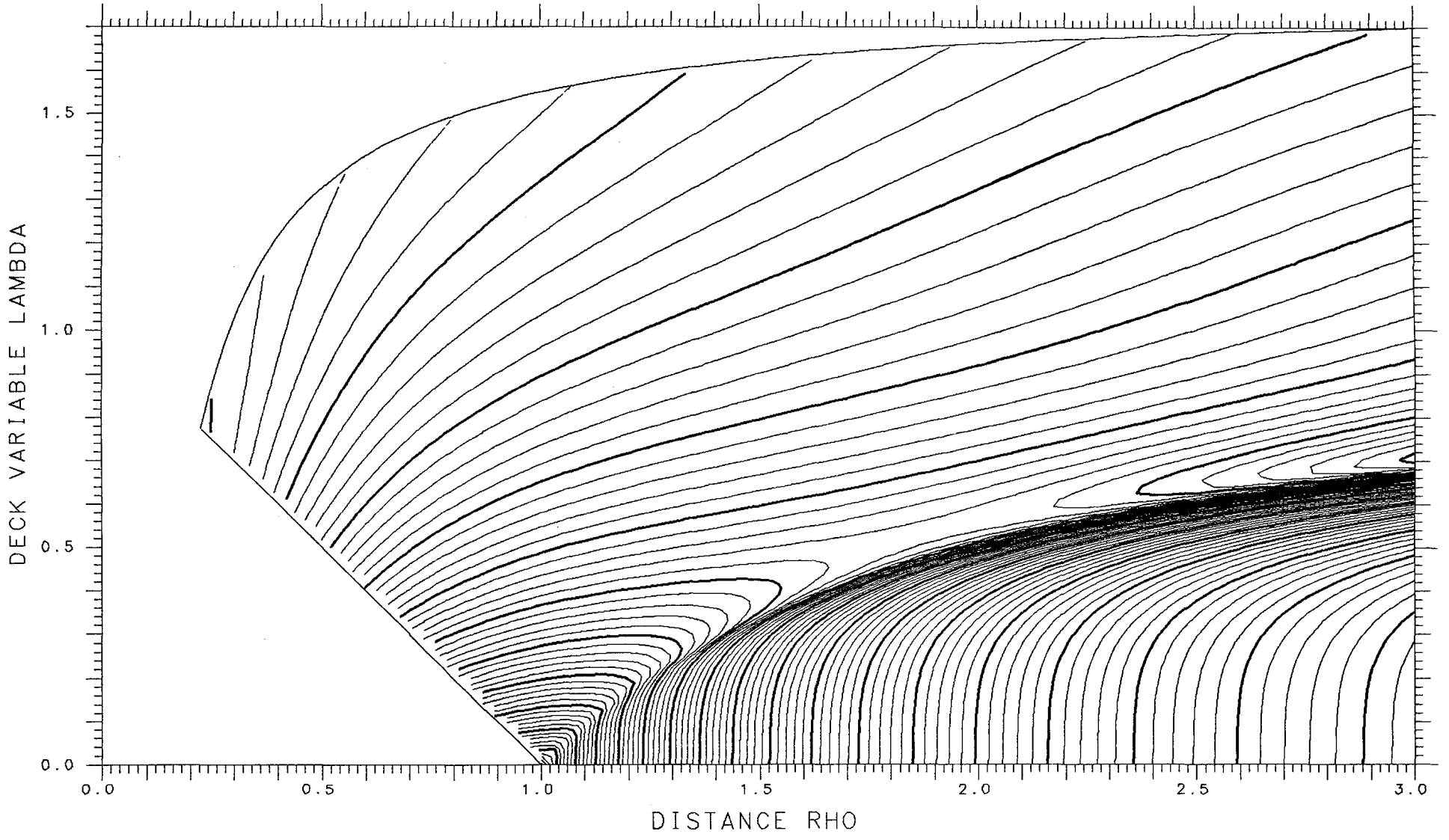

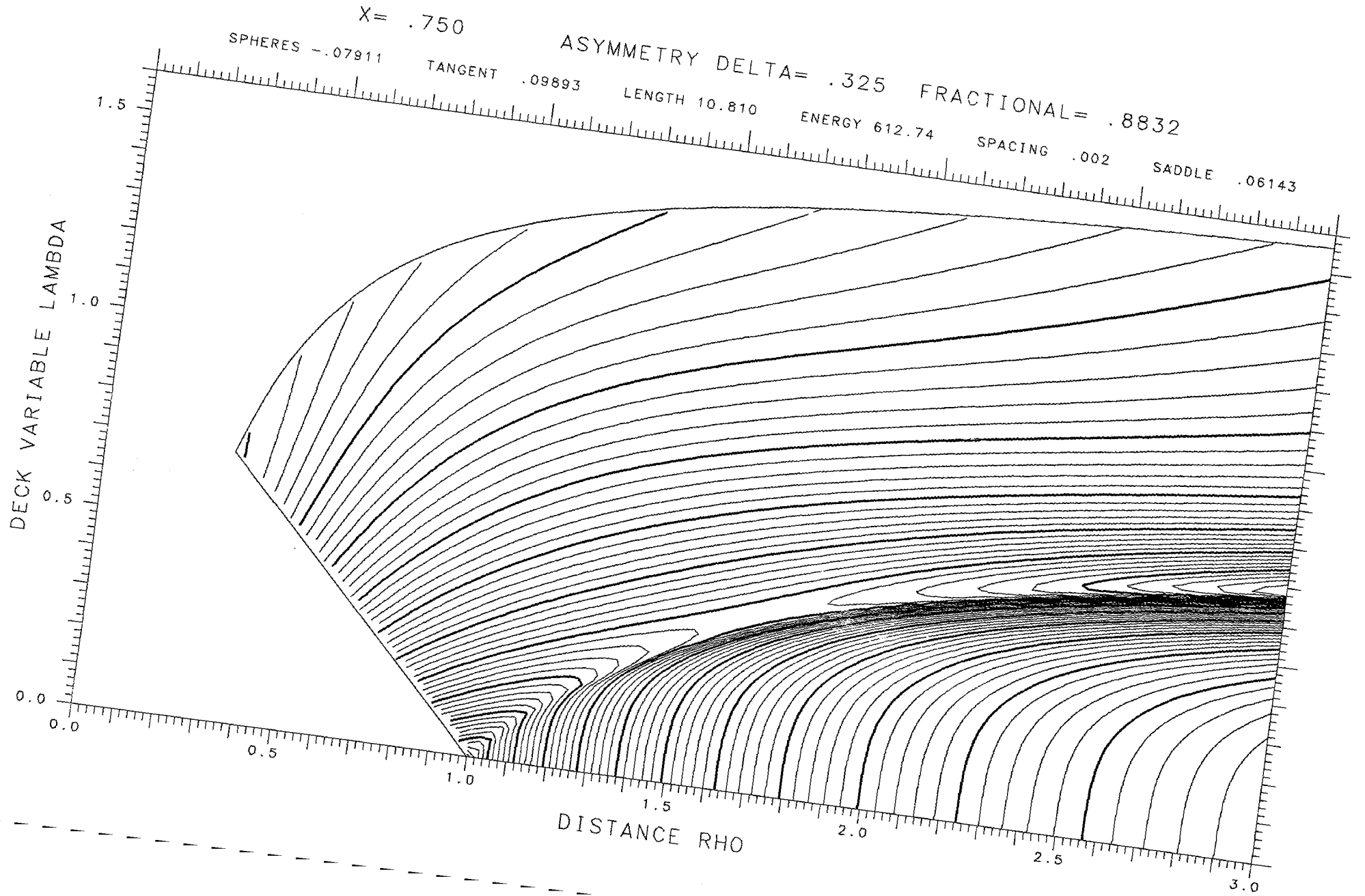

X = .725 ASYMMETRY DELTA = .250 FRACTIONAL = .8224

SPHERES - .12818 TANGENT .10733 LENGTH 11.038 ENERGY 598.24 SPACING .002 SADDLE .05261

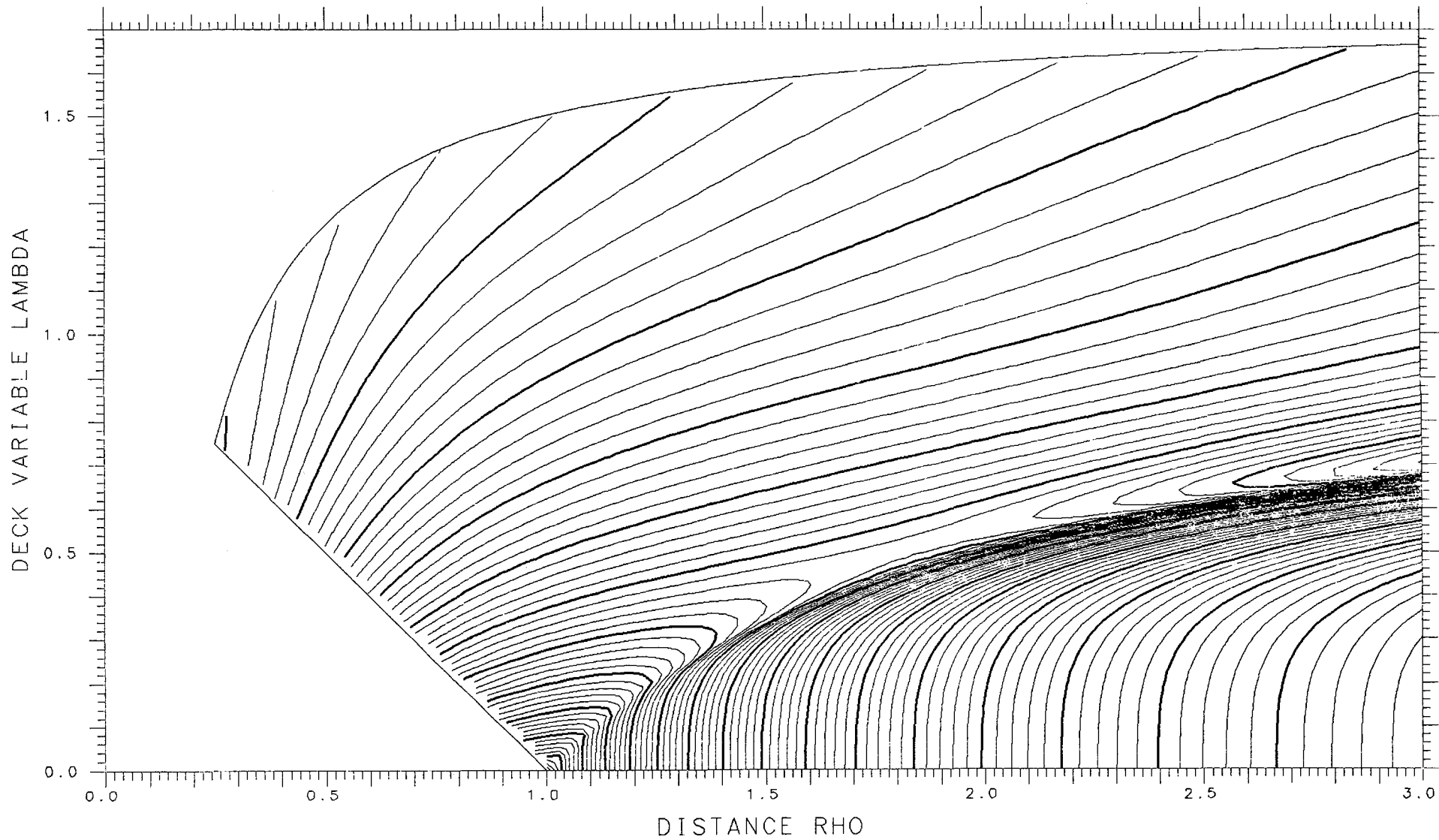

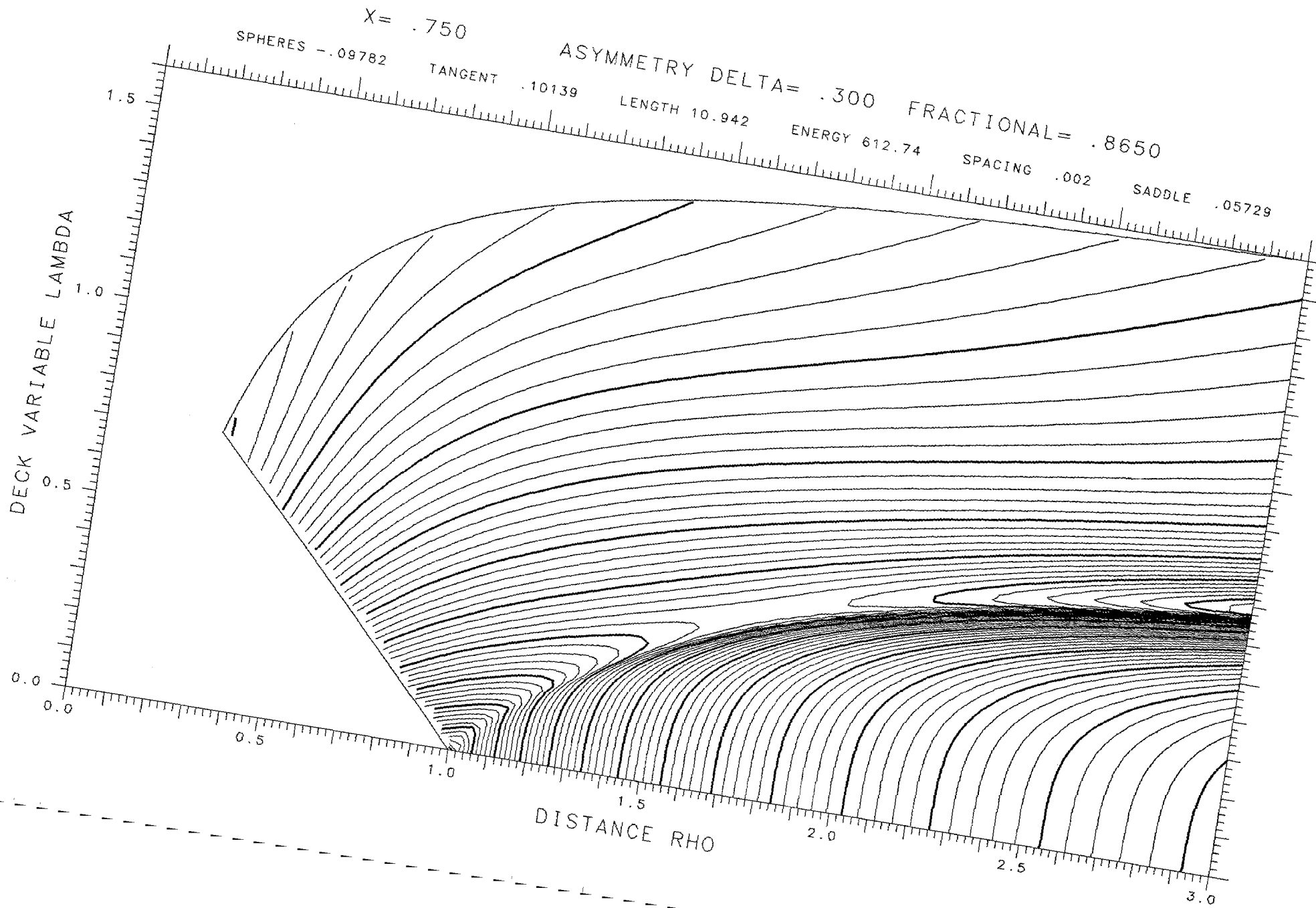

X= .725 ASYMMETRY DELTA= .275 FRACTIONAL= .8447

SPHERES -.10796 TANGENT .10584 LENGTH 10.919 ENERGY 598.24 SPACING .002 SADDLE .05791

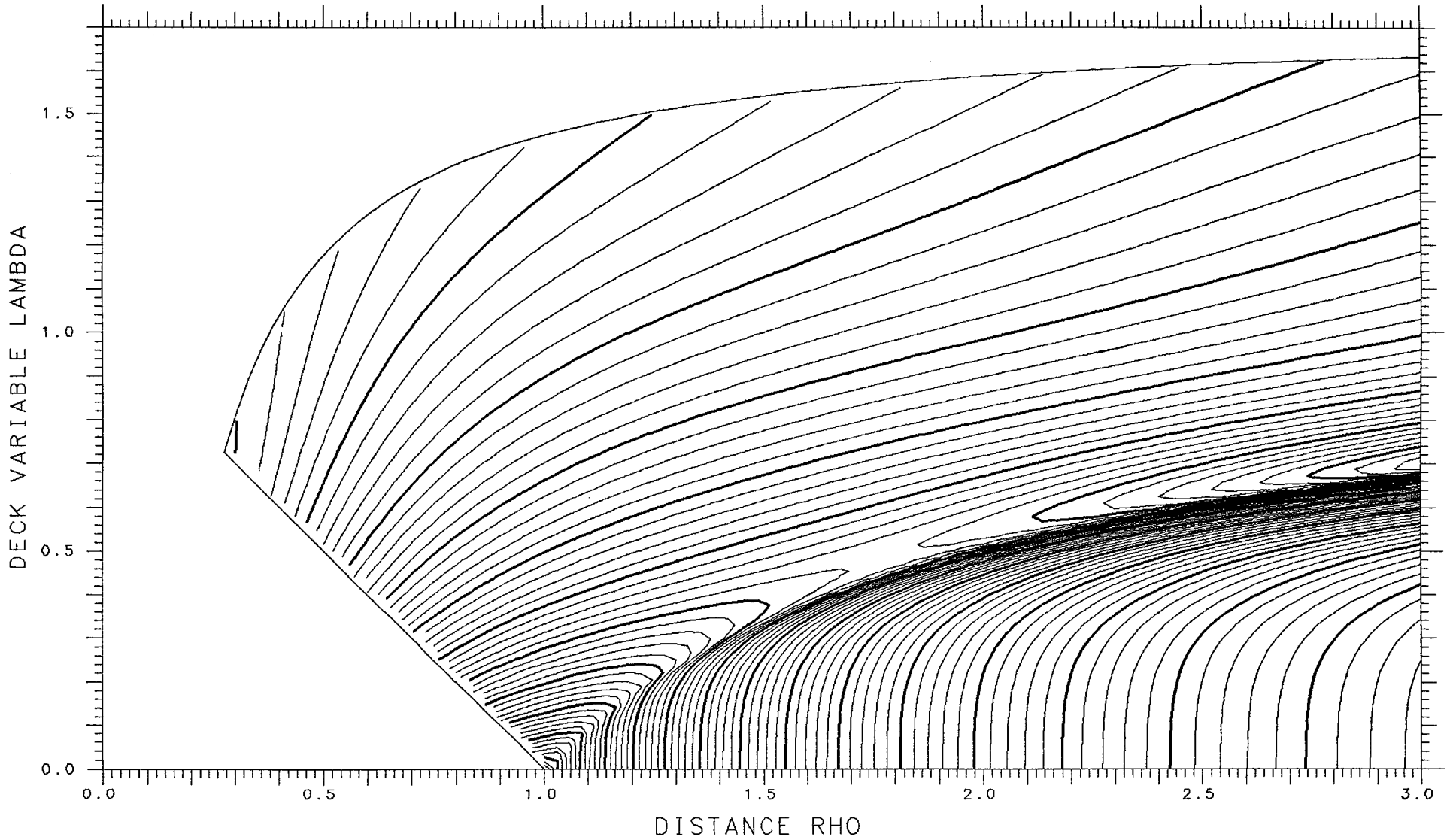

X= .750 ASYMMETRY DELTA= .275 FRACTIONAL= .8447

SPHERES -.11798 TANGENT .10320 LENGTH 11.069 ENERGY 612.74 SPACING .002 SADDLE .05209

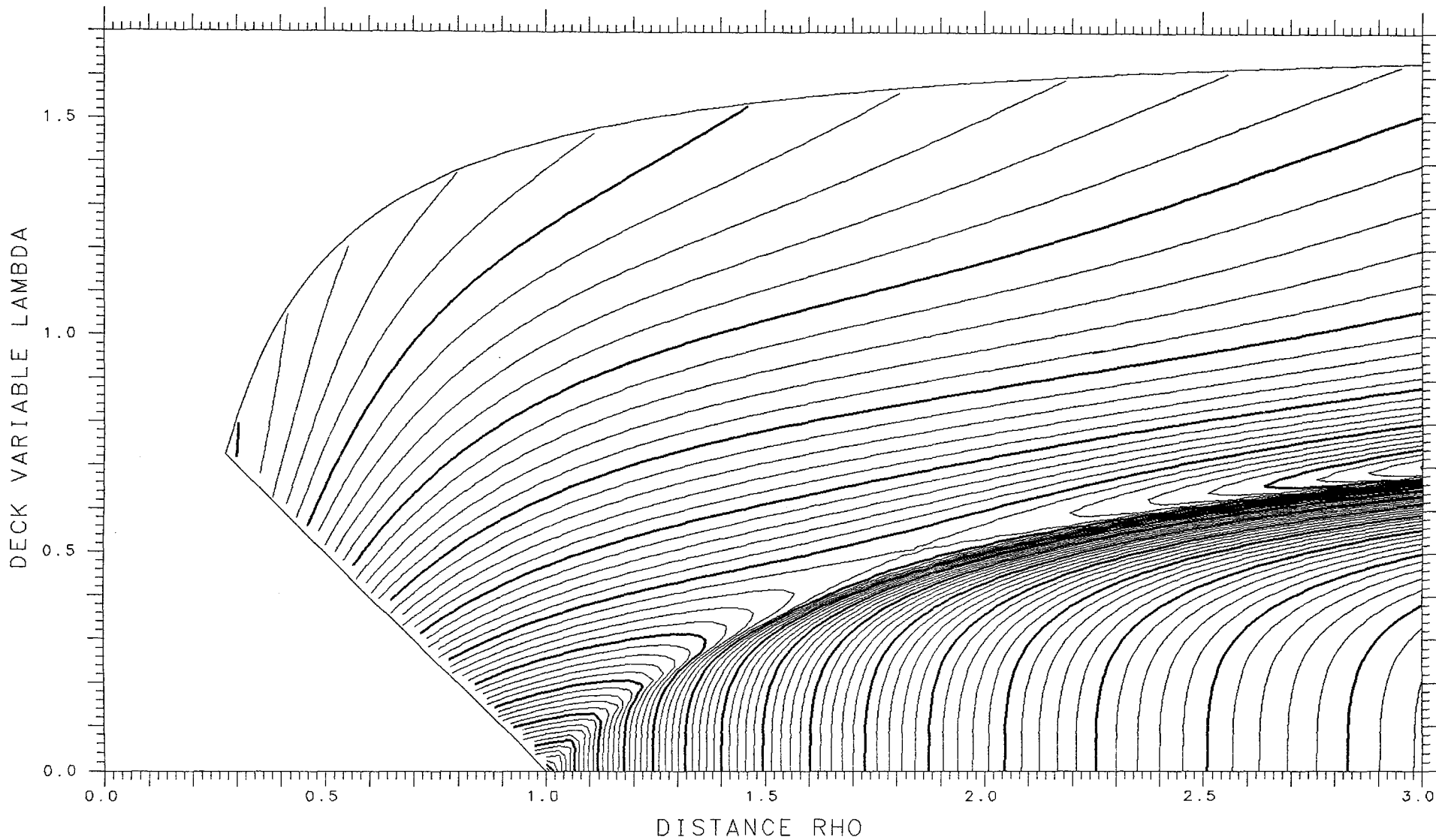

X= .725 ASYMMETRY DELTA= .300 FRACTIONAL= .8650

SPHERES -.08886 TANGENT .10371 LENGTH 10.794 ENERGY 598.24 SPACING .002 SADDLE .06234

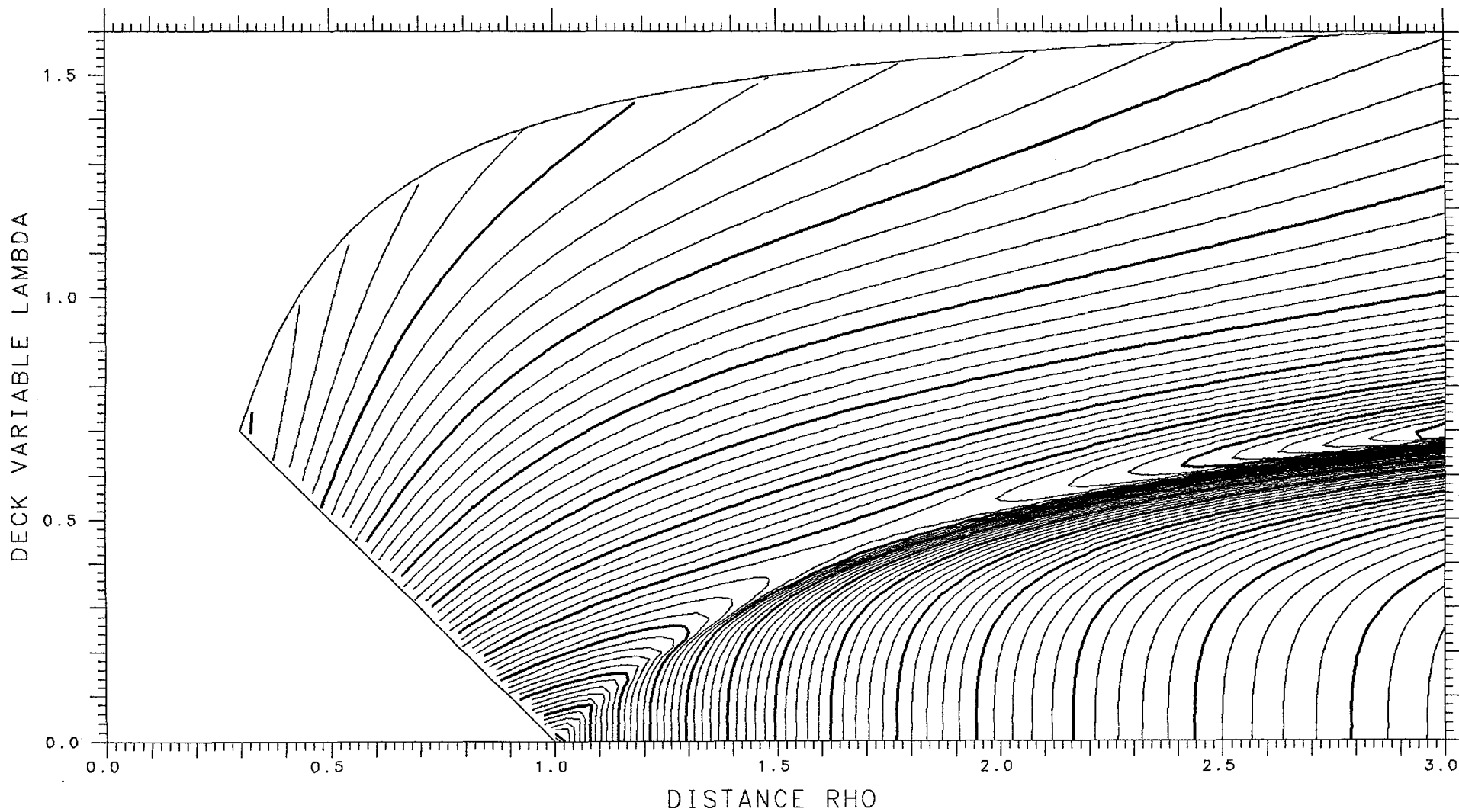

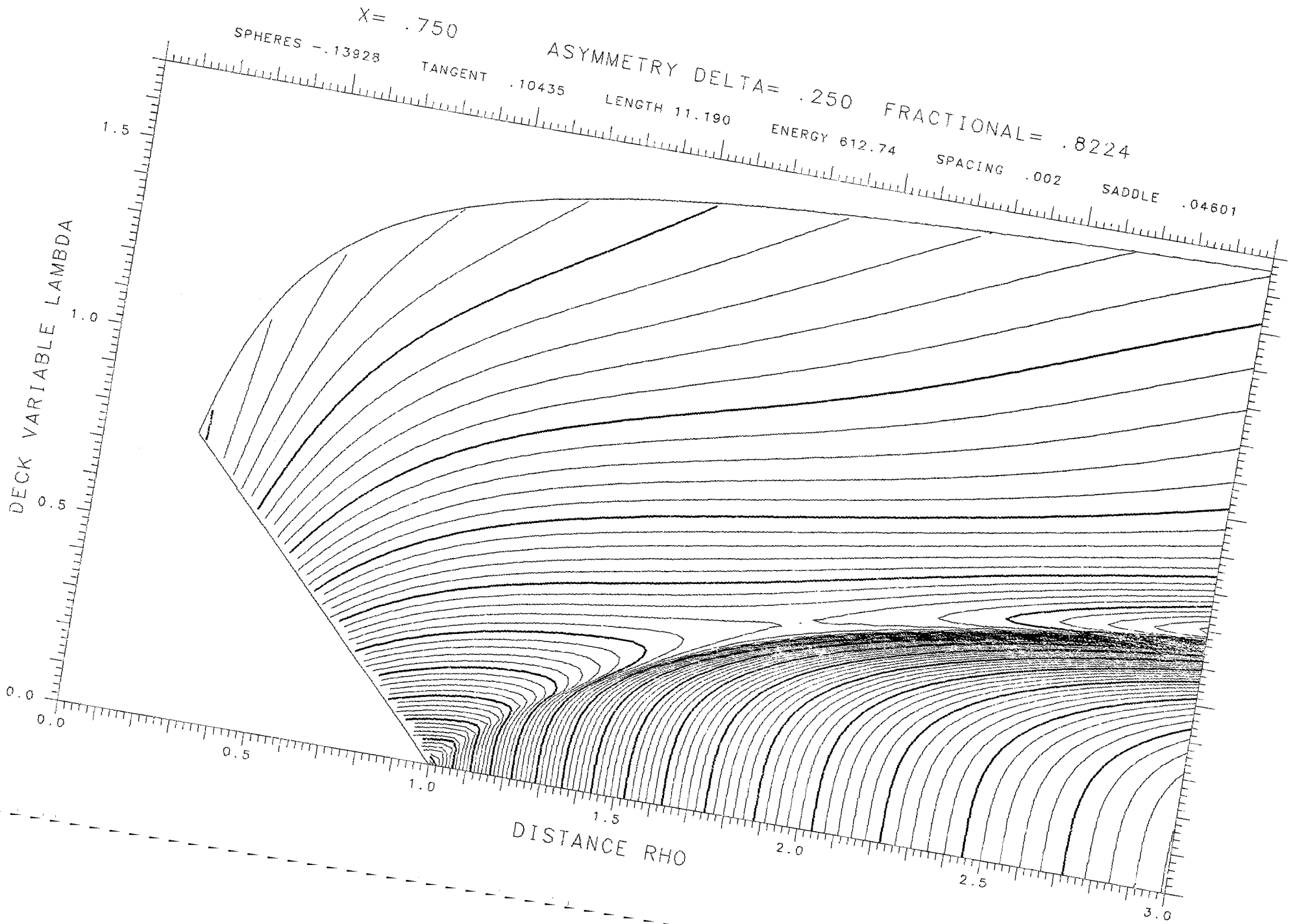

X= .725 ASYMMETRY DELTA= .325 FRACTIONAL= .8832

SPHERES -.07116 TANGENT .10095 LENGTH 10.664 ENERGY 598.24 SPACING .002 SADDLE .06575

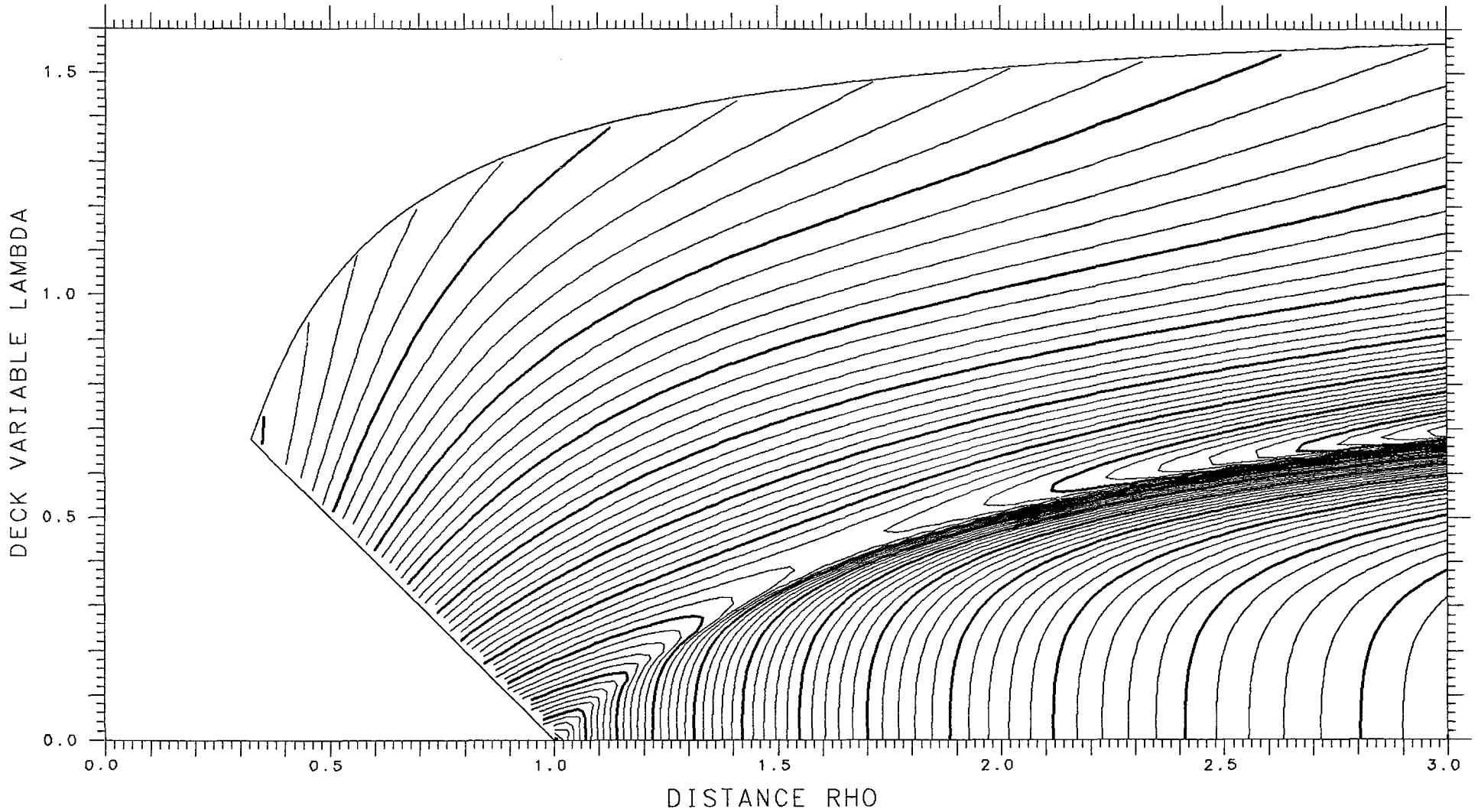

X= .750 ASYMMETRY DELTA= .225 FRACTIONAL= .7979

SPHERES -.16130 TANGENT .10487 LENGTH 11.304 ENERGY 612.74 SPACING .002 SADDLE .03932

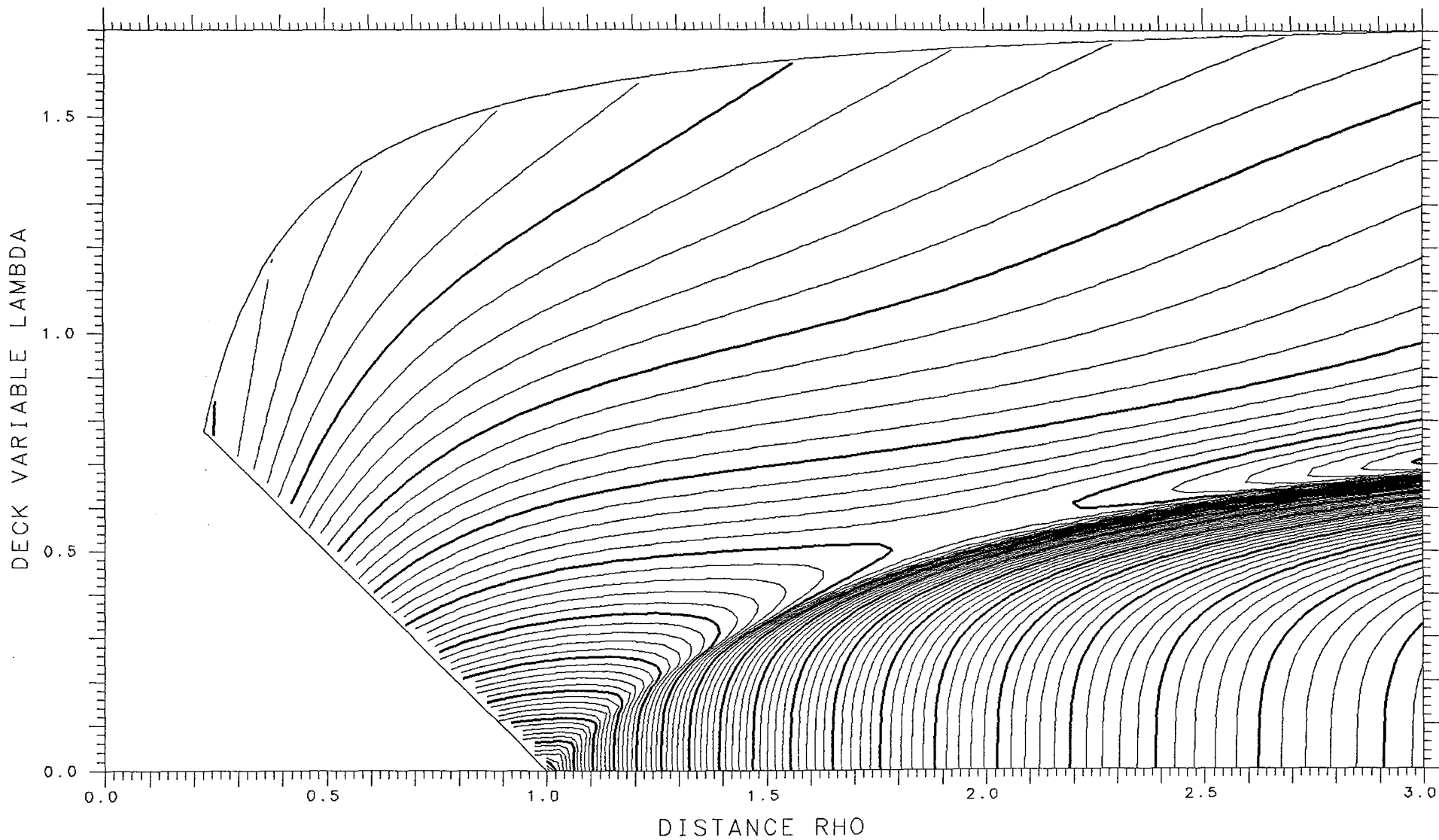

X= .725 ASYMMETRY DELTA= .350 FRACTIONAL= .8996

SPHERES -.05507 TANGENT .09757 LENGTH 10.531 ENERGY 598.24 SPACING .002 SADDLE .06804

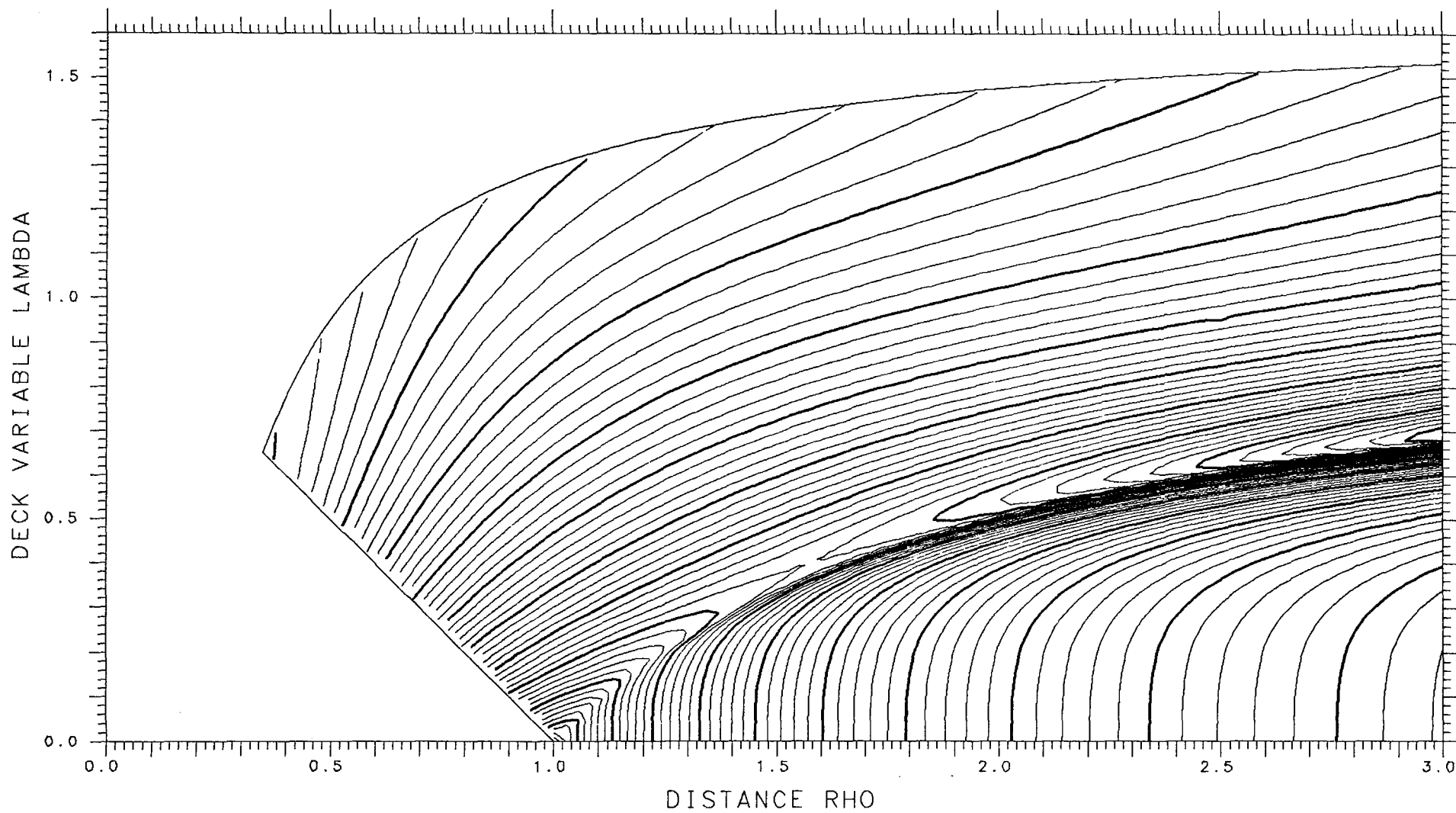

X= .750 ASYMMETRY DELTA= .200 FRACTIONAL= .7714

SPHERES -.18355 TANGENT .10484 LENGTH 11.410 ENERGY 612.74 SPACING .002 SADDLE .03237

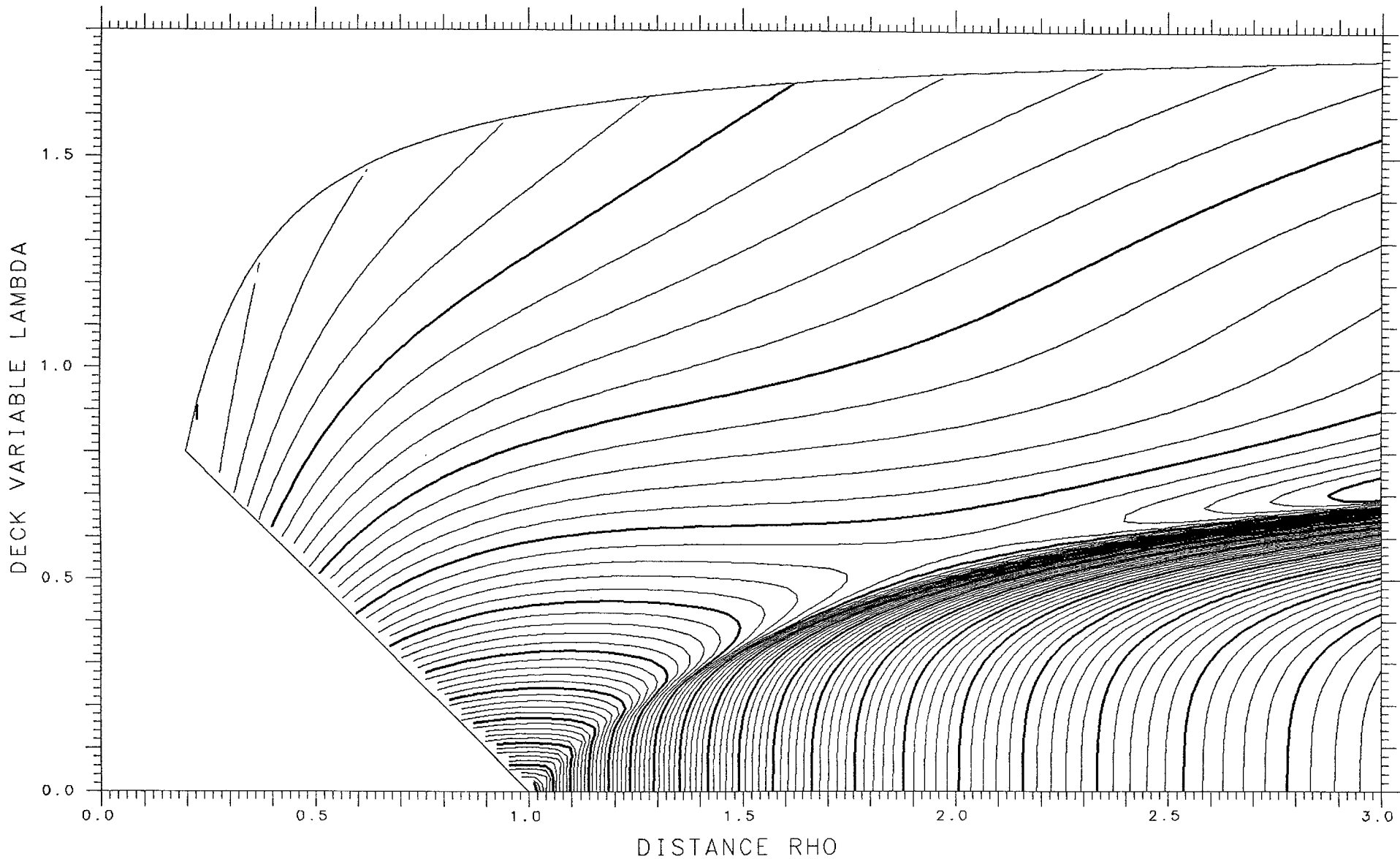

X= .725 ASYMMETRY DELTA= .375 FRACTIONAL= .9141

SPHERES -.04073 TANGENT .09362 LENGTH 10.395 ENERGY 598.24 SPACING .002 SADDLE .06920

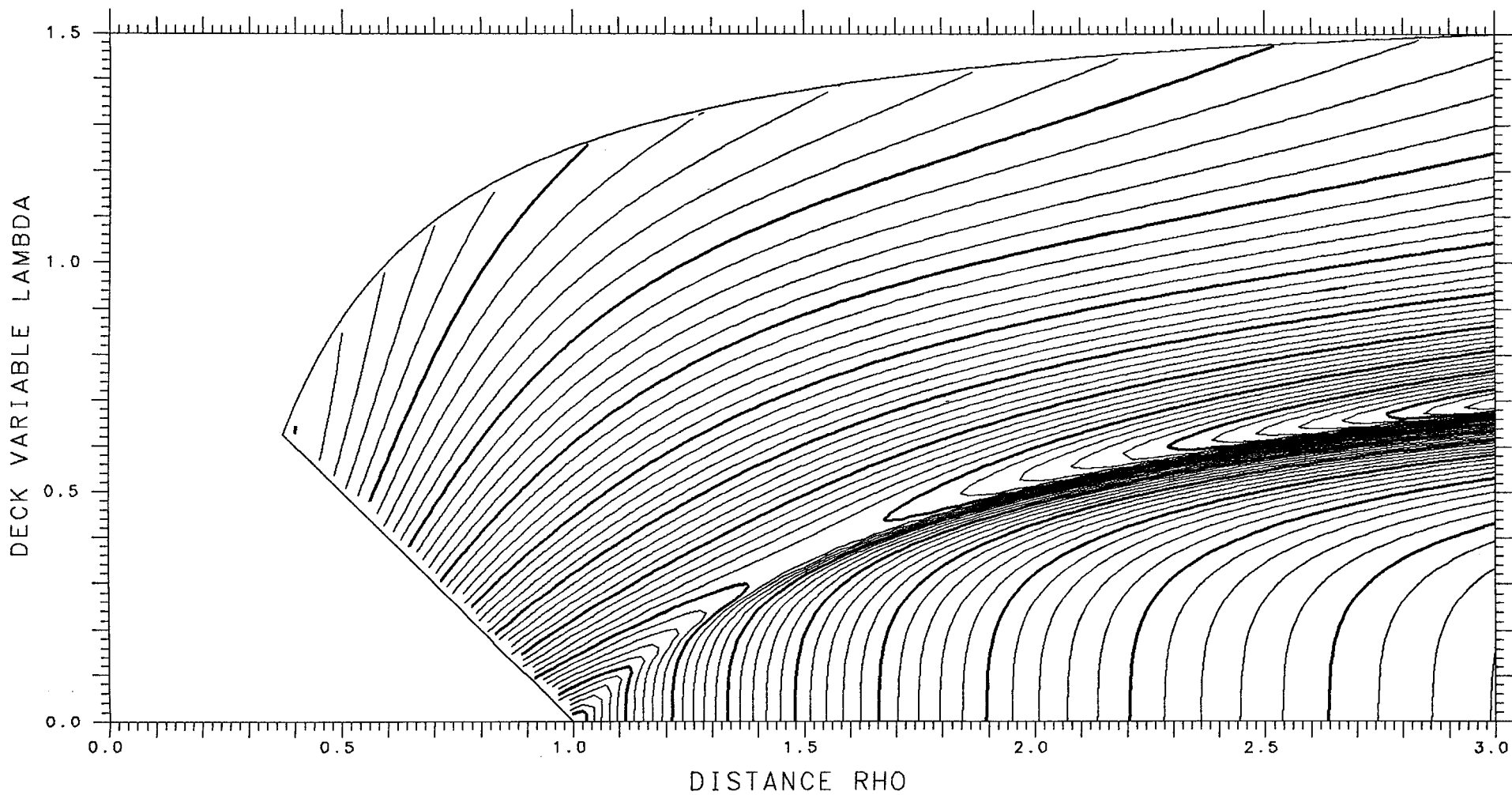

X= .750 ASYMMETRY DELTA= .175 FRACTIONAL= .7429

SPHERES -.20544 TANGENT .10433 LENGTH 11.507 ENERGY 612.74 SPACING .002 SADDLE .02561

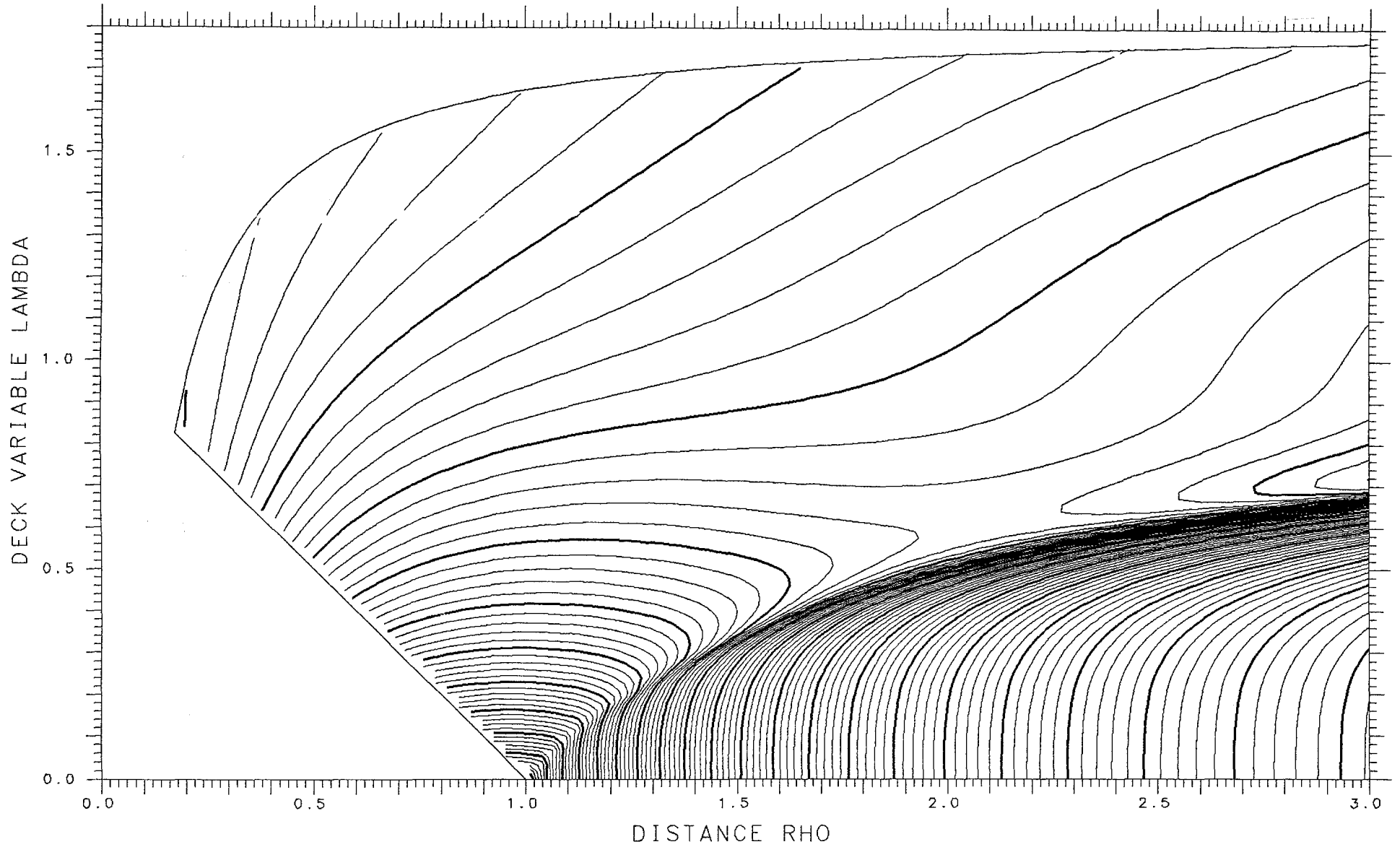

X= .725 ASYMMETRY DELTA= .400 FRACTIONAL= .9270

SPHERES -.02818 TANGENT .08916 LENGTH 10.257 ENERGY 598.24 SPACING .002 SADDLE .06925

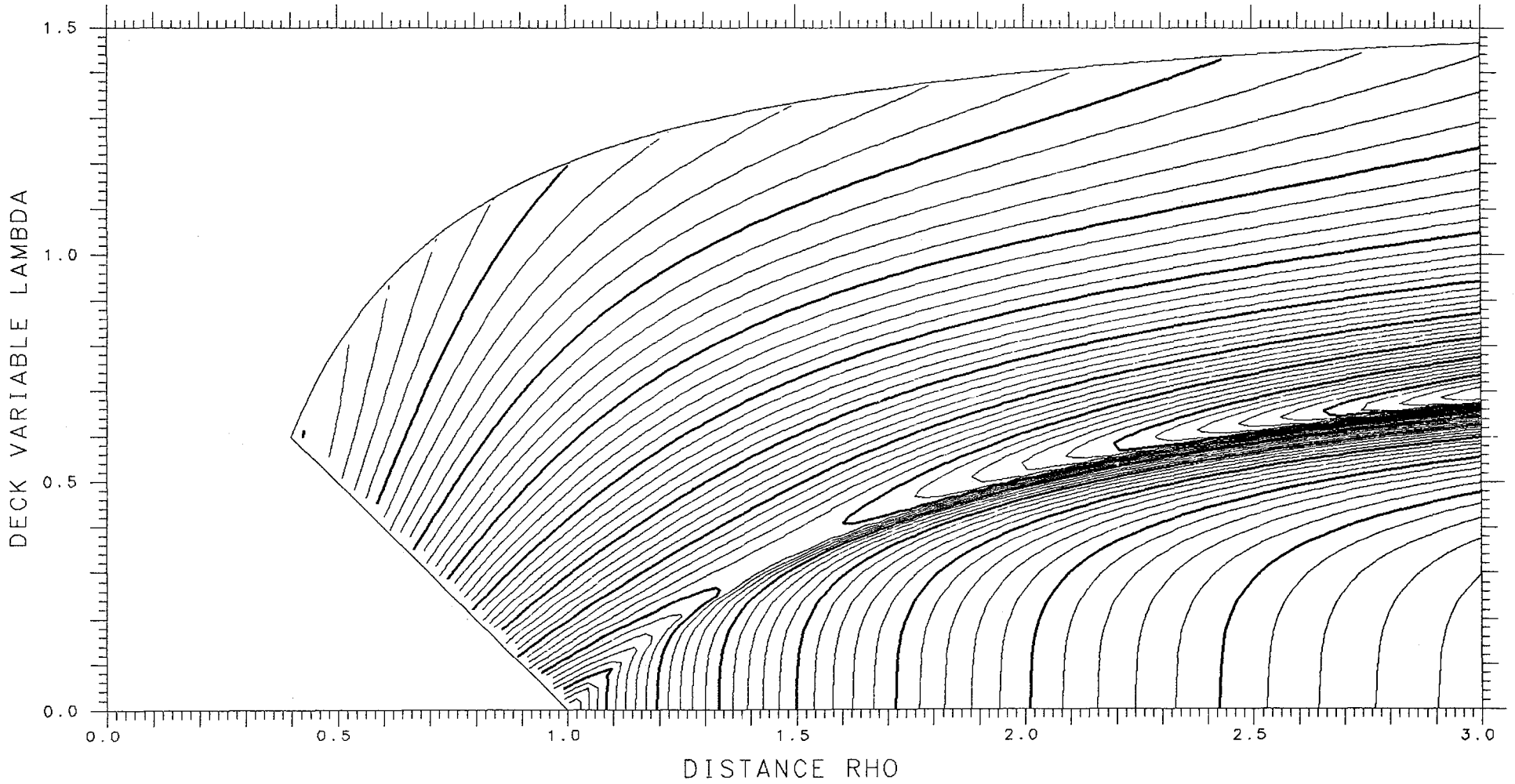

X= .750 ASYMMETRY DELTA= .150 FRACTIONAL= .7124

SPHERES -.22633 TANGENT .10348 LENGTH 11.594 ENERGY 612.74 SPACING .002 SADDLE .01973

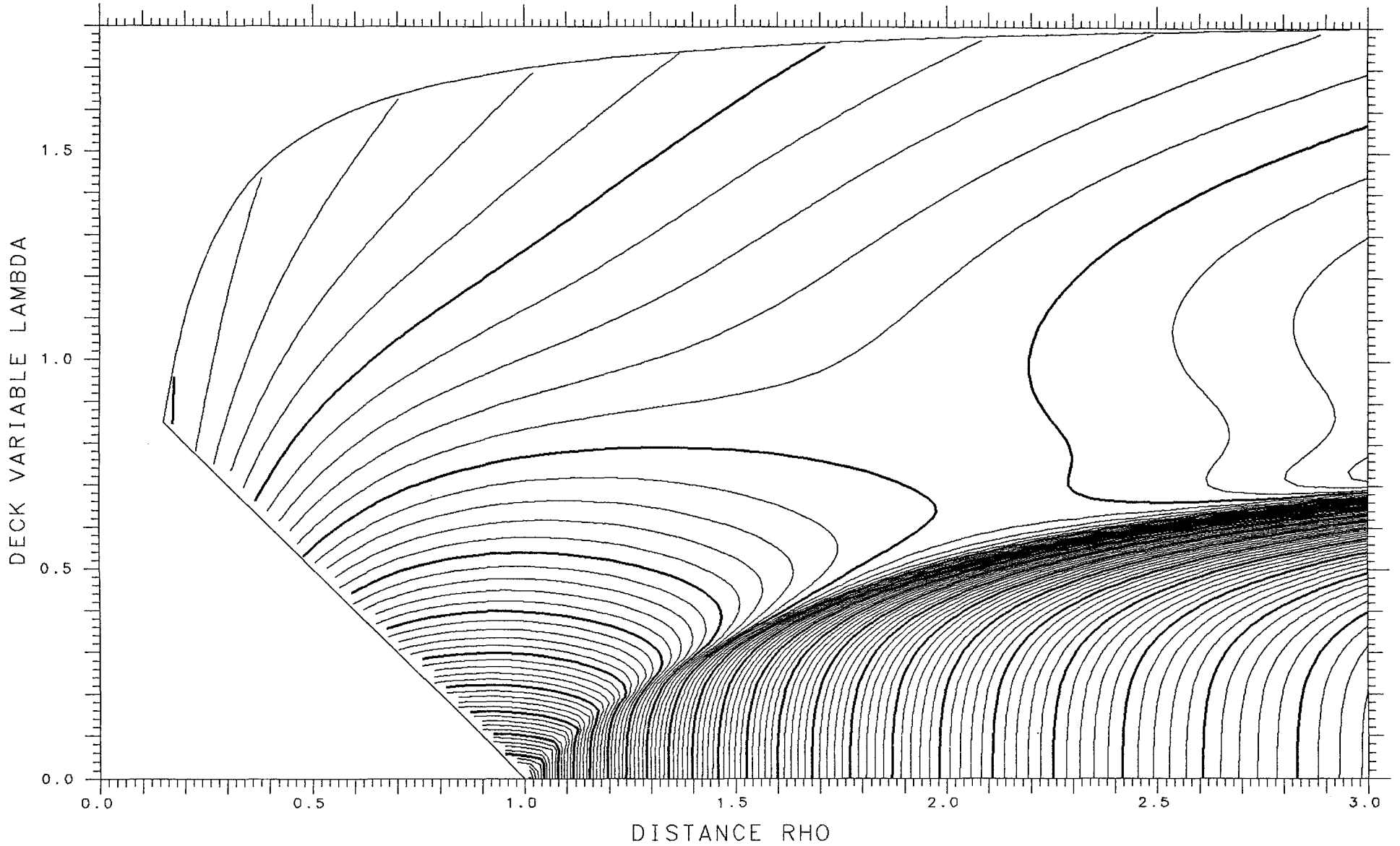

X= .725 ASYMMETRY DELTA= .425 FRACTIONAL= .9384

SPHERES -.01743 TANGENT .08431 LENGTH 10.118 ENERGY 598.24 SPACING .002 SADDLE .06828

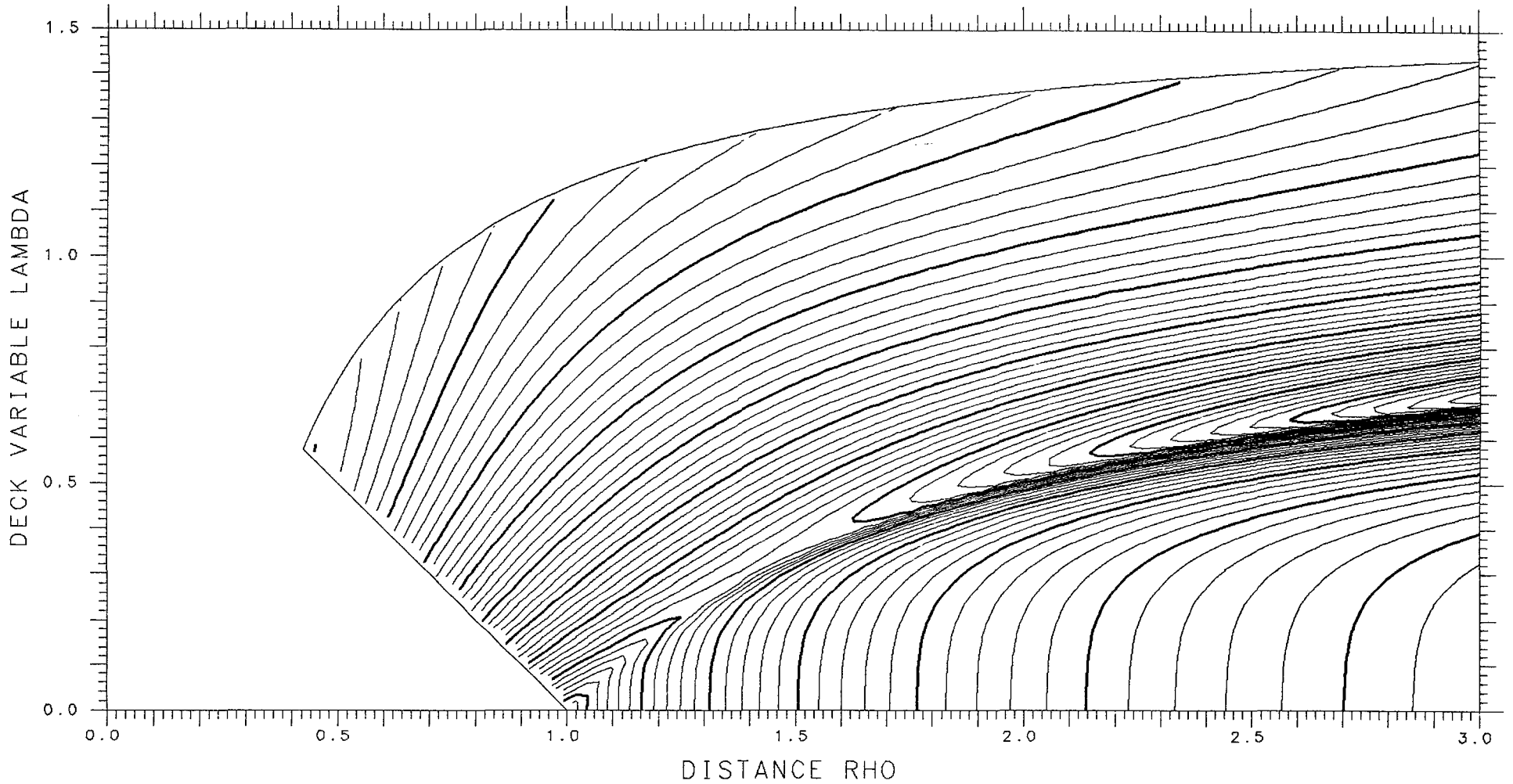

X= .750 ASYMMETRY DELTA= .125 FRACTIONAL= .6800

SPHERES -.24554 TANGENT .10241 LENGTH 11.670 ENERGY 612.74 SPACING .002 SADDLE .01721

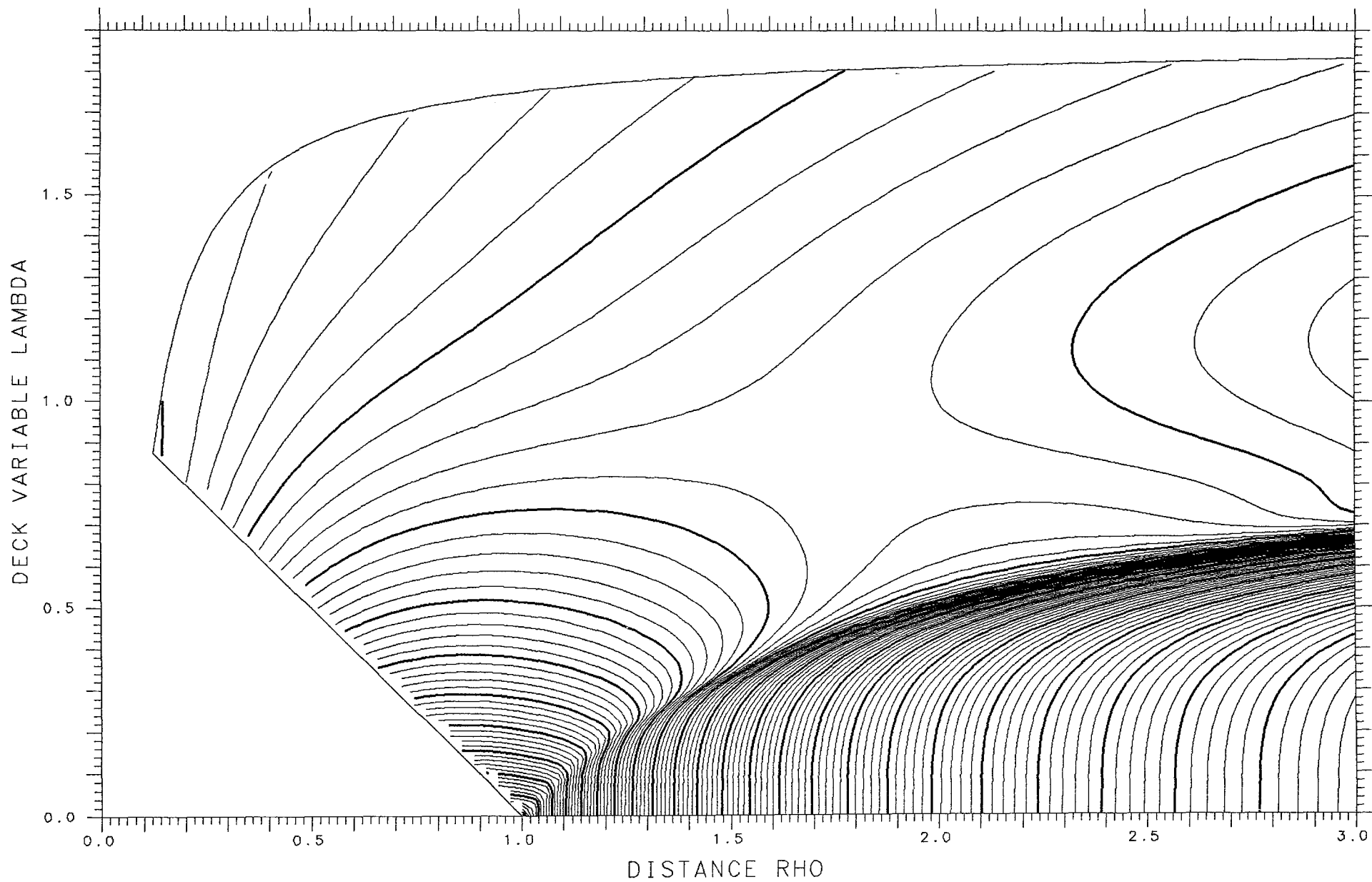

X= .725 ASYMMETRY DELTA= .450 FRACTIONAL= .9483

SPHERES -.00841 TANGENT .07911 LENGTH 9.978 ENERGY 598.24 SPACING .002

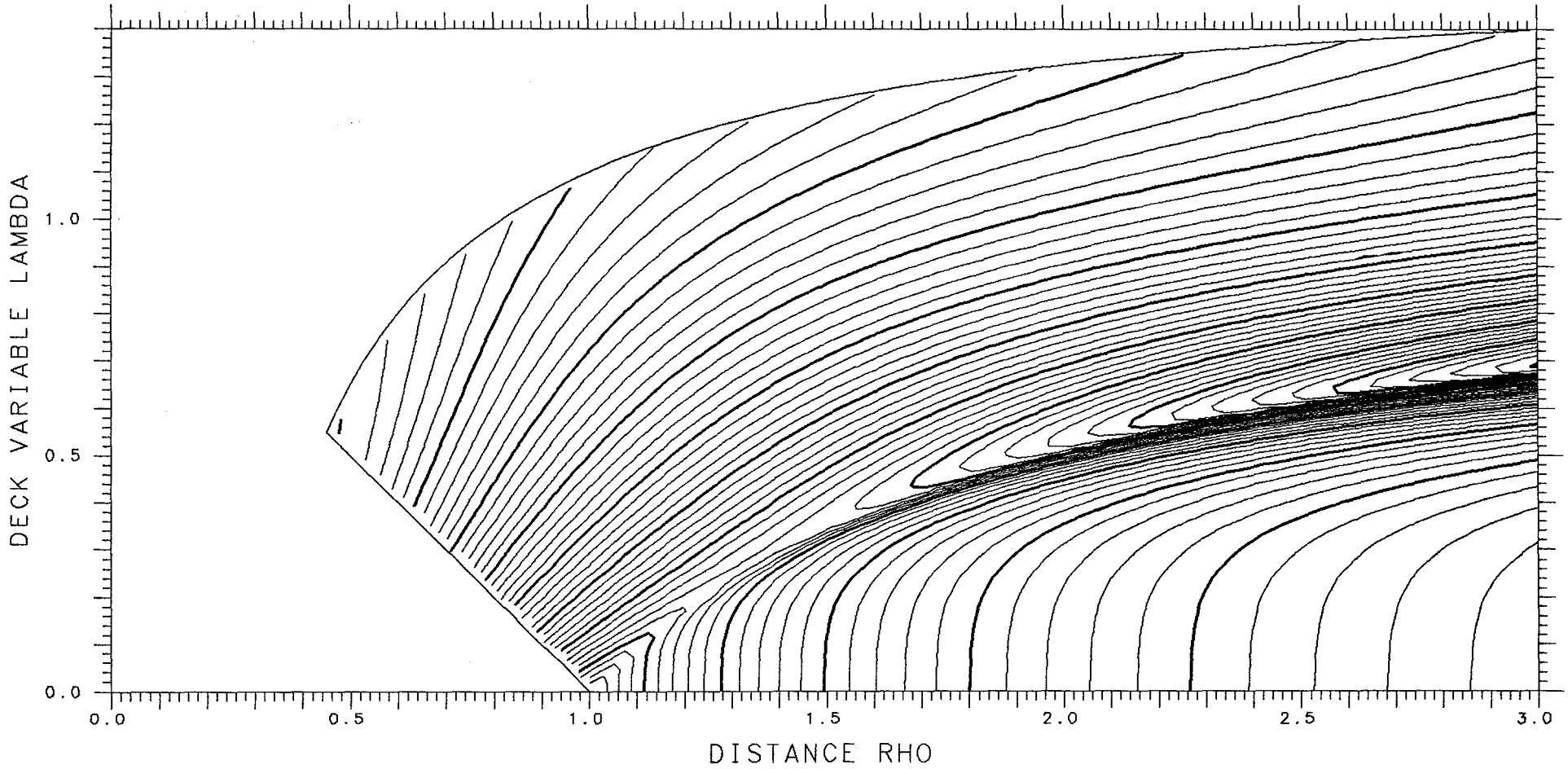

X= .750 ASYMMETRY DELTA= .100 FRACTIONAL= .6461

SPHERES -.26239 TANGENT .10127 LENGTH 11.733 ENERGY 612.74 SPACING .002 SADDLE .01577

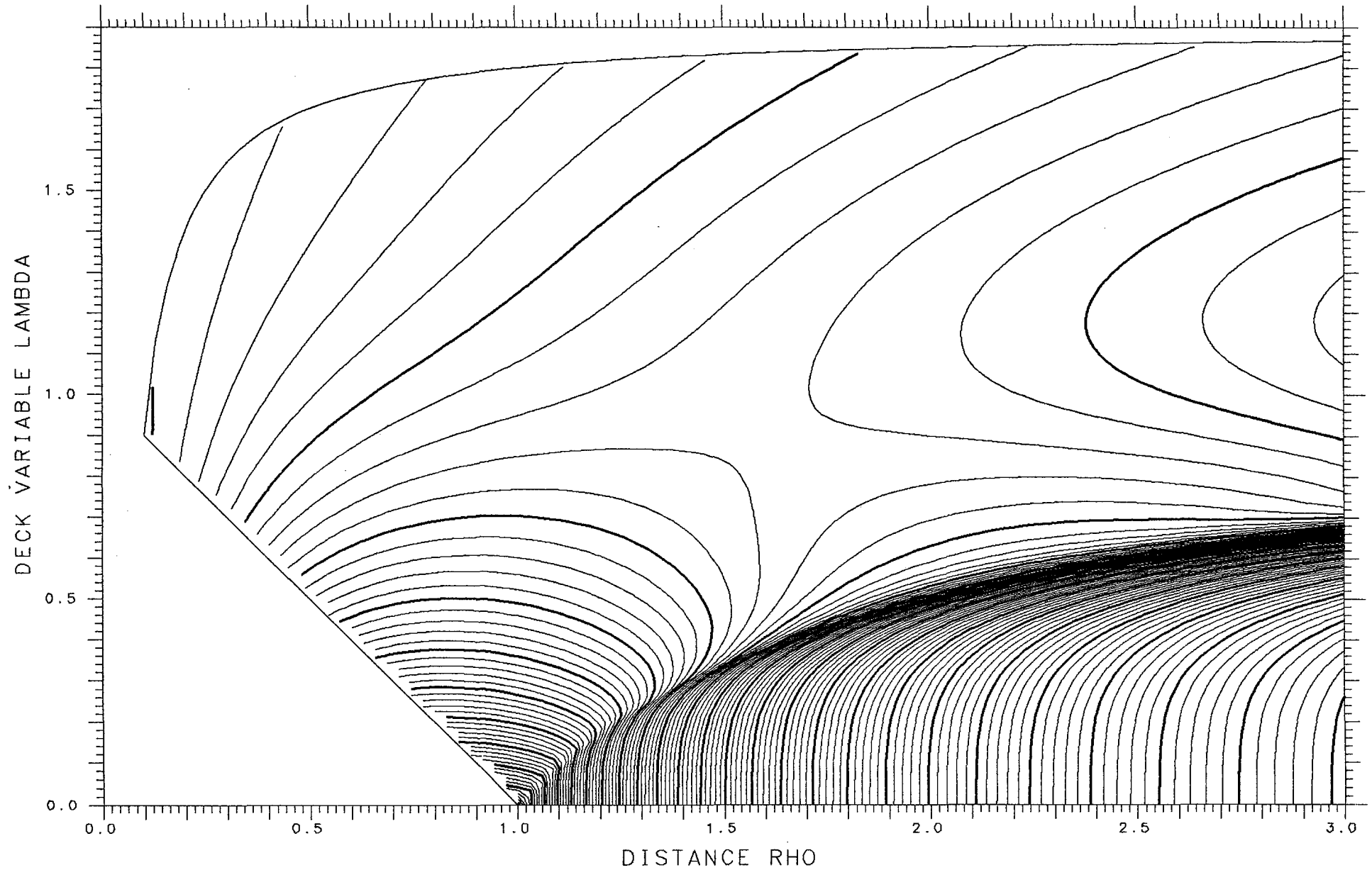

X= .725 ASYMMETRY DELTA= .475 FRACTIONAL= .9569

SPHERES -.00103 TANGENT .07365 LENGTH 9.839 ENERGY 598.24 SPACING .002

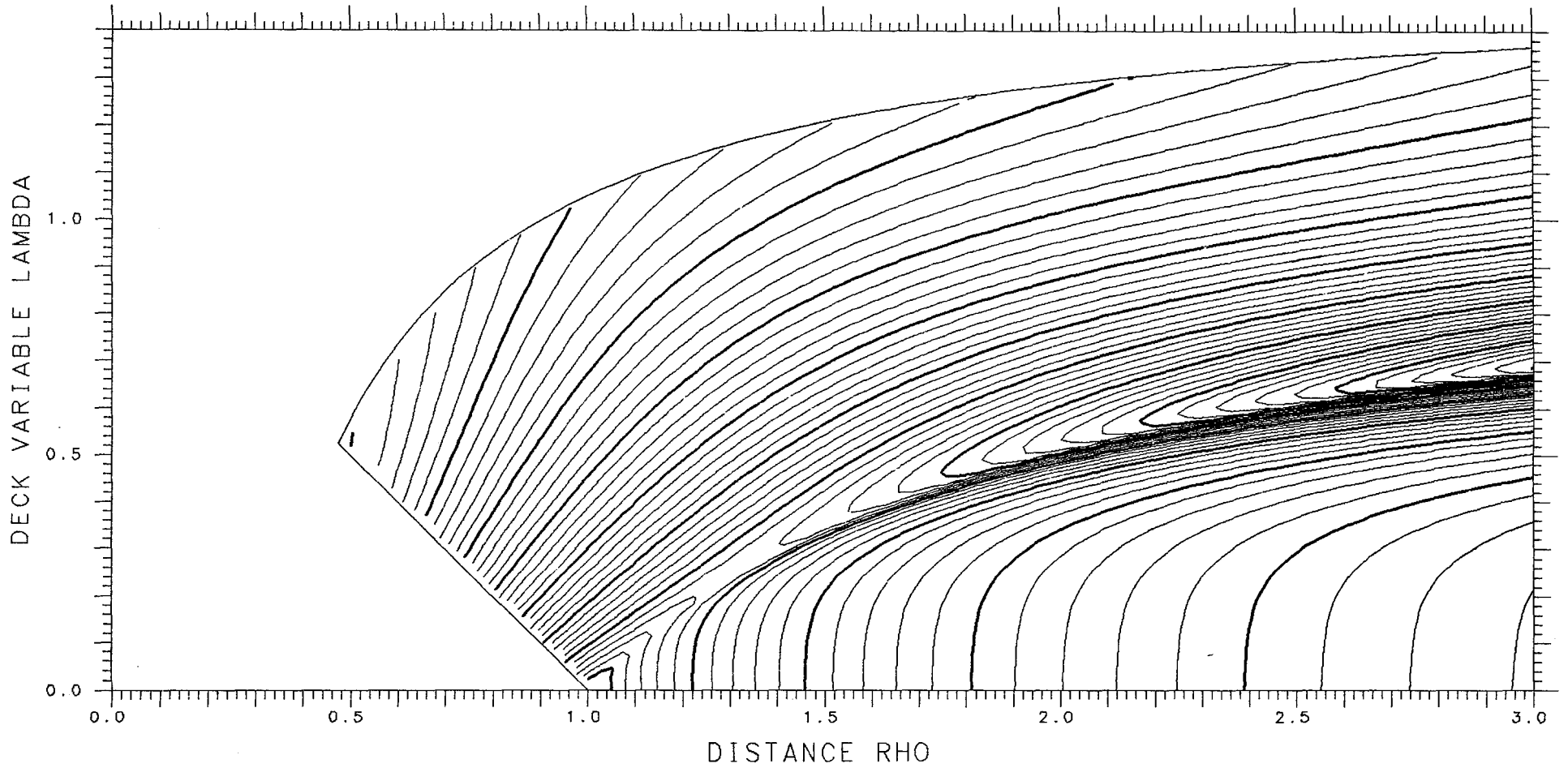

X= .750 ASYMMETRY DELTA= .075 FRACTIONAL= .6108

SPHERES -.27626 TANGENT .10021 LENGTH 11.783 ENERGY 612.74 SPACING .002 SADDLE .01475

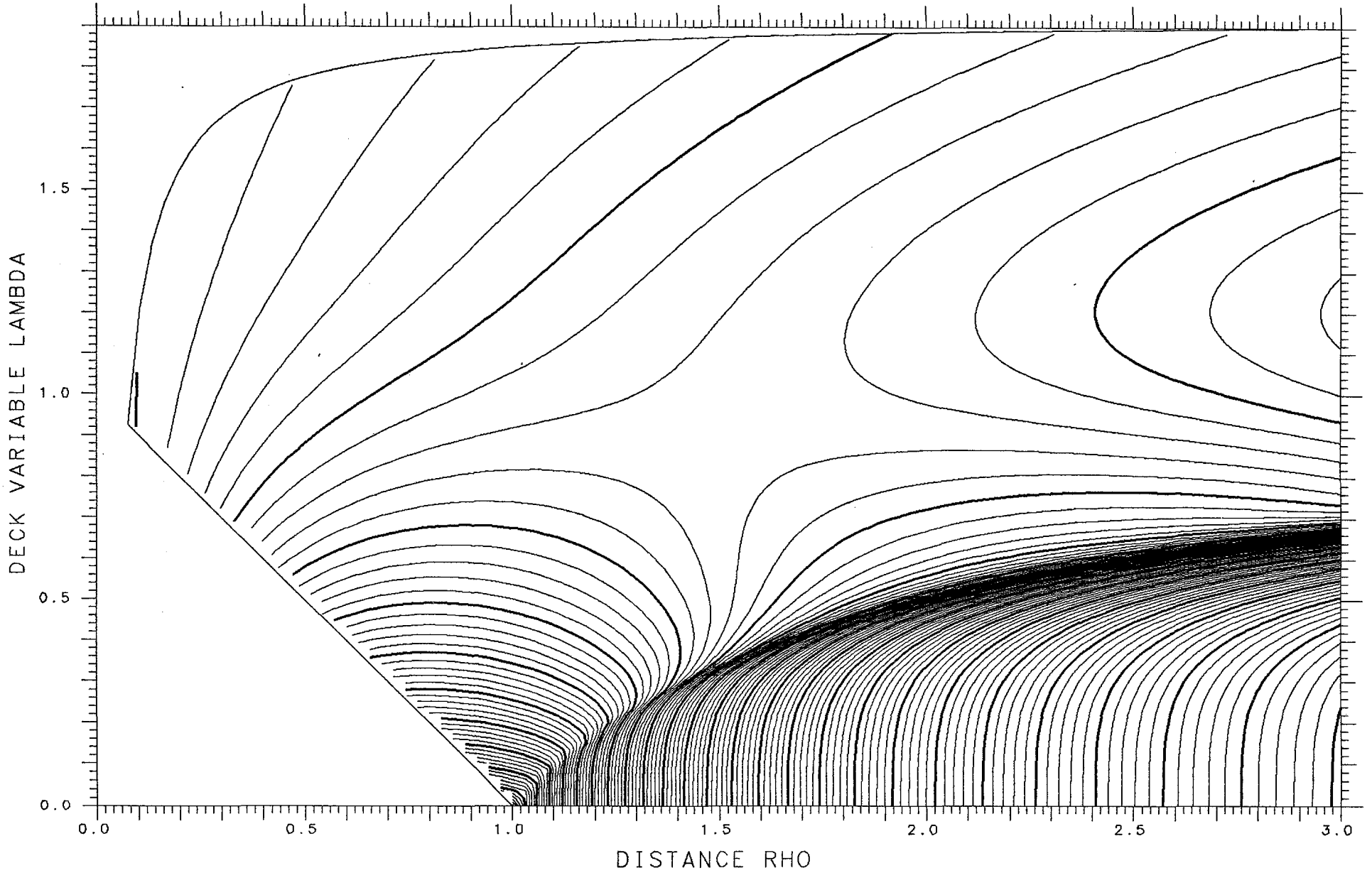

X= .725 ASYMMETRY DELTA= .500 FRACTIONAL= .9643

SPHERES .00483 TANGENT .06802 LENGTH 9.700 ENERGY 598.24 SPACING .002

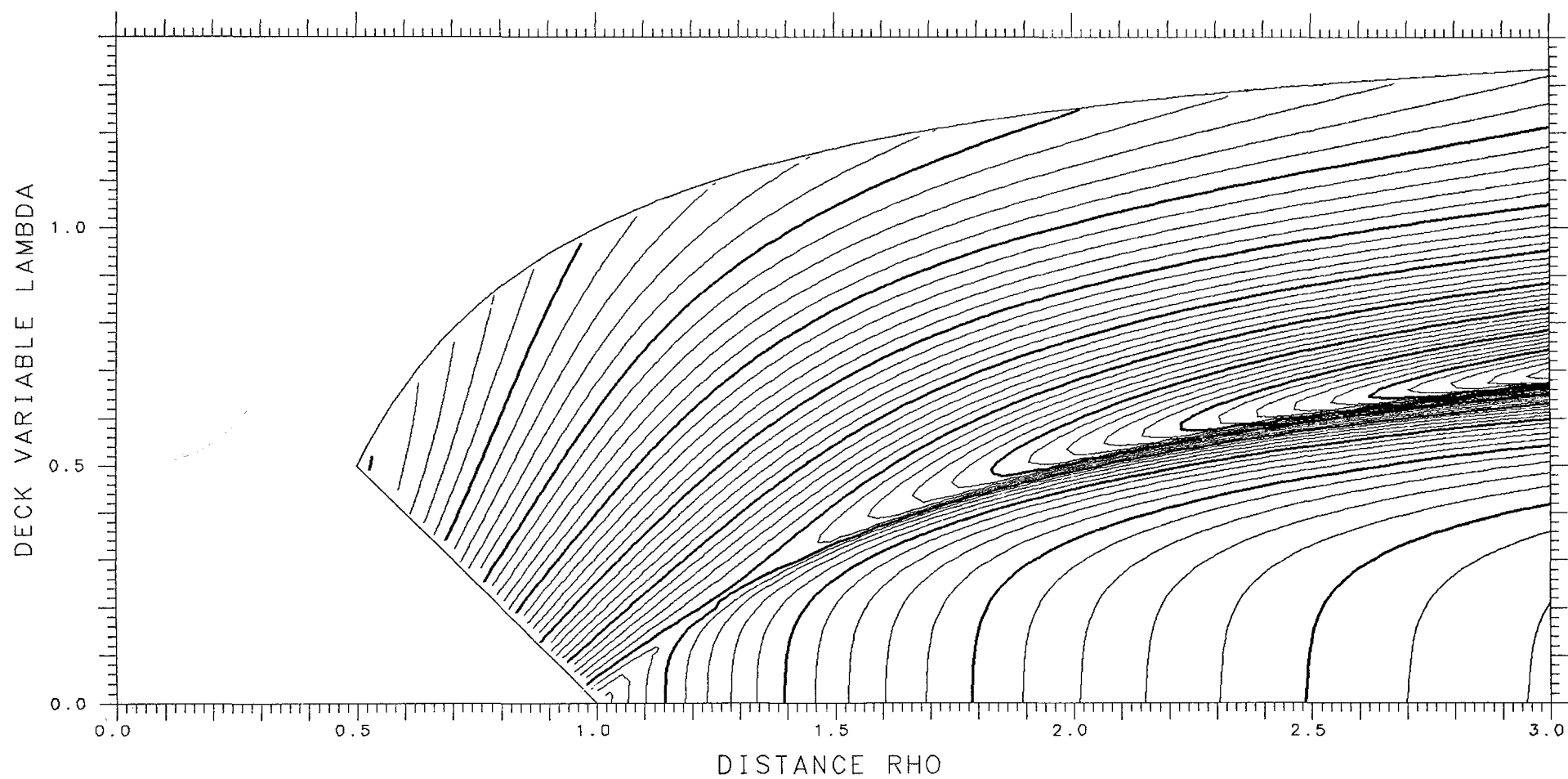

X= .750 ASYMMETRY DELTA= .050 FRACTIONAL= .5745

SPHERES -.28660 TANGENT .09934 LENGTH 11.820 ENERGY 612.74 SPACING .002 SADDLE .01405

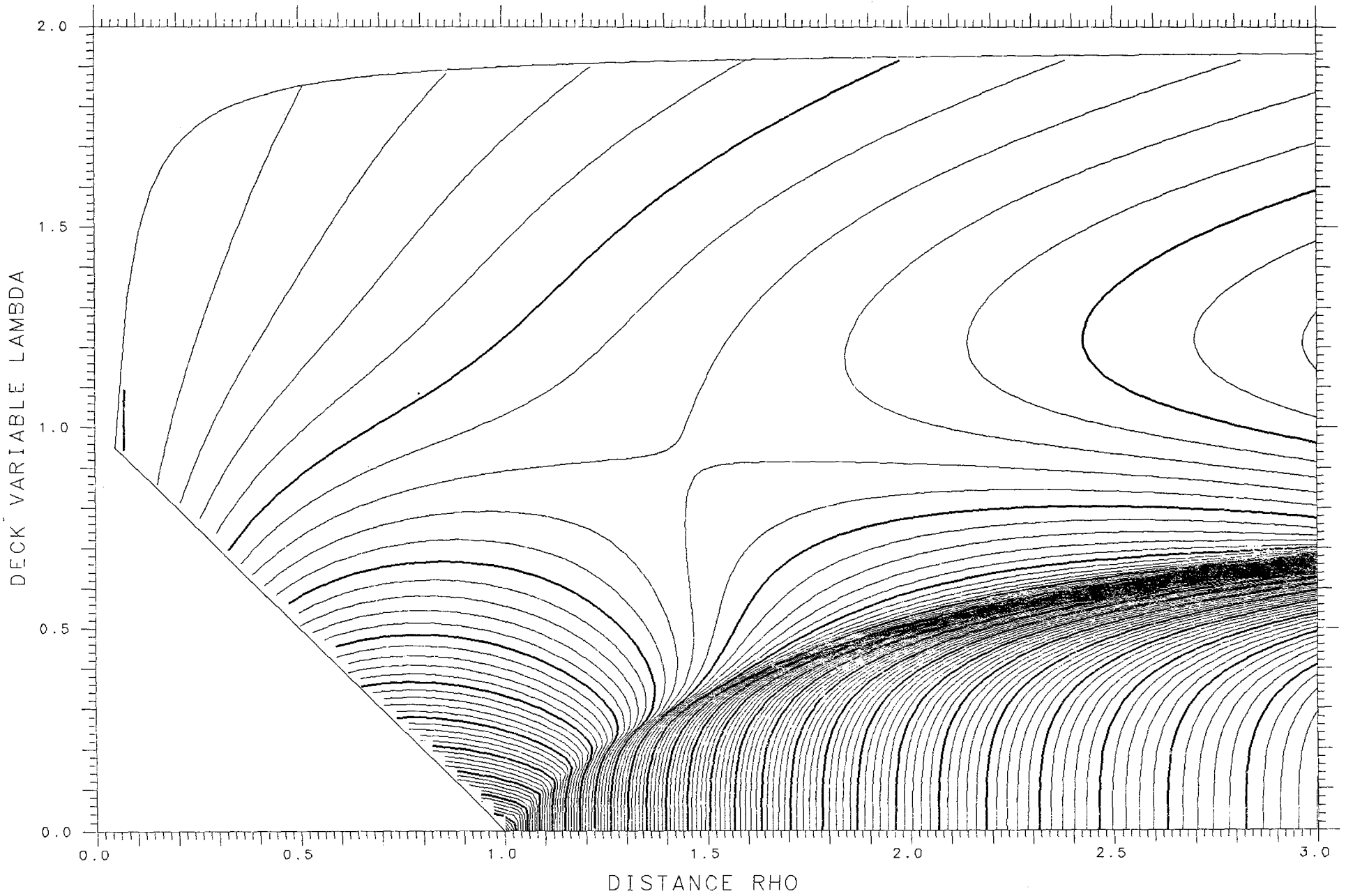

X= .725 ASYMMETRY DELTA= .525 FRACTIONAL= .9707

SPHERES .00931 TANGENT .06230 LENGTH 9.562 ENERGY 598.24 SPACING .002

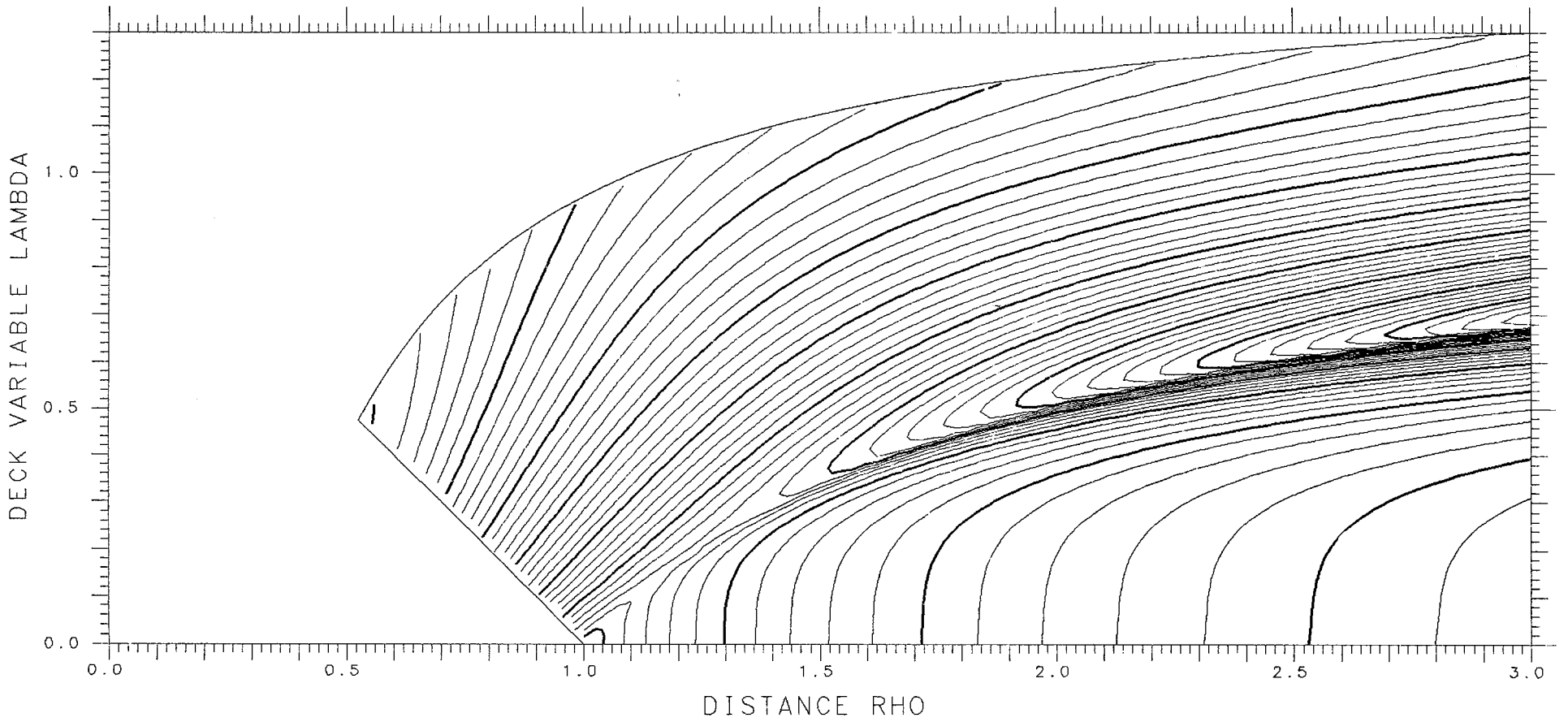

X= .750

ASYMMETRY DELTA= .025

FRACTIONAL= .5374

SPHERES -.29298

TANGENT .09878

LENGTH 11.842

ENERGY 612.74-

SPACING .002

SADDLE .01364

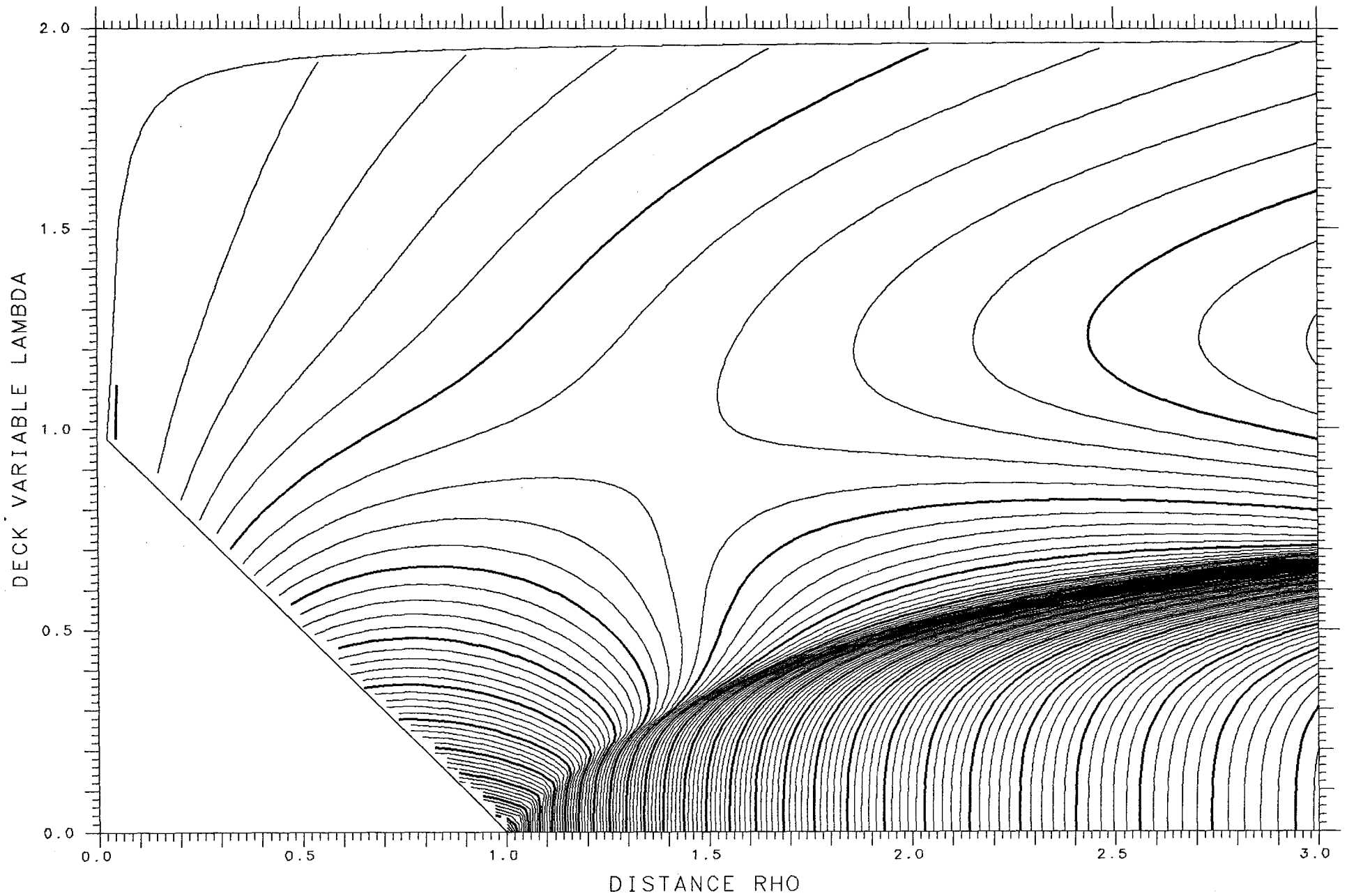

X= .725 ASYMMETRY DELTA= .550 FRACTIONAL= .9761

SPHERES .01256 TANGENT .05658 LENGTH 9.425 ENERGY 598.24 SPACING .002

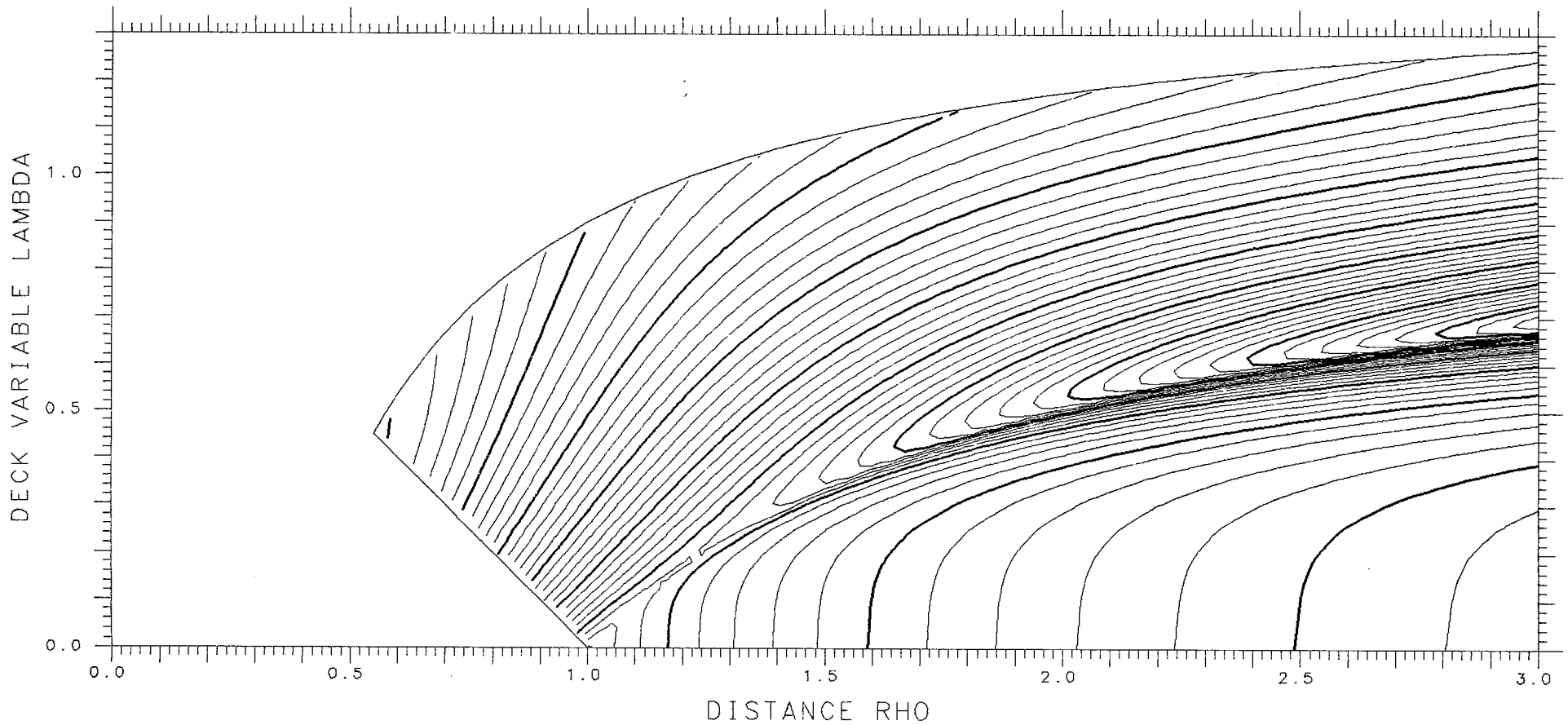

X= .750

ASYMMETRY DELTA=0.

FRACTIONAL= .5000

SPHERES -.29514

TANGENT .09859

LENGTH 11.849

ENERGY 612.74

SPACING .002

SADDLE .01350

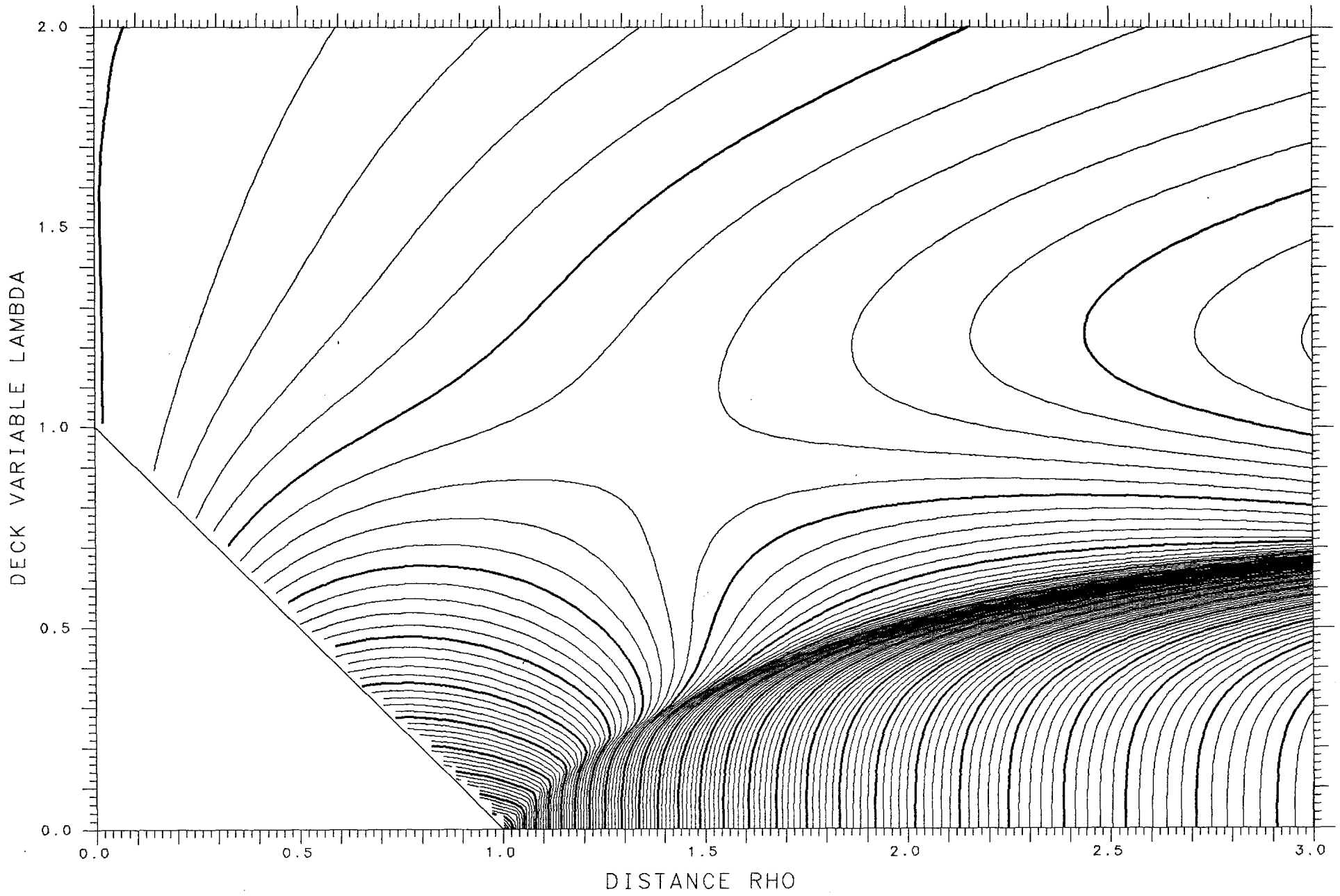

X= .725 ASYMMETRY DELTA= .575 FRACTIONAL= .9807

SPHERES .01473 TANGENT .05093 LENGTH 9.290 ENERGY 598.24 SPACING .002

