

Lawrence Berkeley National Laboratory

Lawrence Berkeley National Laboratory

Title

The Reduction of the Critical Currents in Nb₃Sn Cables under Transverse Loads

Permalink

<https://escholarship.org/uc/item/0wz1q4s7>

Author

Van Oort, J.M.

Publication Date

1992-08-01

THE REDUCTION OF THE CRITICAL CURRENT IN Nb₃Sn
CABLES UNDER TRANSVERSE LOADS

J.M. van Oort, R.M. Scanlan,
Lawrence Berkeley Laboratory,
Accelerator and Fusion Research Division,
Superconducting Magnet Group,
1, Cyclotron Road, Berkeley, CA 94720, USA.

H.W. Weijers, S. Wessel, H.H.J. ten Kate
University of Twente,
Applied Superconductivity Center,
P.O. Box 217, 7500 AE Enschede, the Netherlands.

Abstract-- The degradation of the critical current of impregnated Rutherford type Nb₃Sn cables is investigated as a function of the applied transverse load and magnetic field. The cable is made of TWCA modified jelly-roll type strand material and has a keystone angle of 1.0 degree. The voltage-current characteristics are determined for the magnetic field ranging from 2 to 11 tesla and transverse pressure up to 250 MPa on the cable surface. It is found that the 48-strand cable, made of strands with 6 elements in the matrix, shows a larger critical current degradation than the 26-strand cable with 36 elements per strand. The global degradation of the 48-strand cable is 63% at 150 MPa, and 40% at 150 MPa for the 26-strand cable. Micro-analysis of the cross-section shows permanent damage to the sharp edge of the cable. The influence of the keystone angle on the critical-current degradation is currently under investigation.

I. INTRODUCTION

An important factor in the design of a high field superconducting dipole magnet is the presence of large compressive forces. These forces can significantly reduce the current carrying capability of the superconducting material in the windings, which is especially important when Nb₃Sn is used. In the case of the 13T Nb₃Sn dipole magnet D20, currently under design at LBL [1], no room is available for a support structure, so the windings will have to support the entire Lorentz force. This will result in transverse compressive stresses in the conductors up to 140 MPa at 13 T.

As a part of the design of a 13 T Nb₃Sn accelerator type dipole magnet, the voltage-current characteristics of two types of cables made of strand material supplied by Teledyne Way Chang Albany (TWCA) are investigated. The strands are of the Modified Jelly Roll type (MJR). The measurements are performed using the test facility at the University of Twente (UT), which is especially designed to test Nb₃Sn cables in a magnetic field up to 11 T and applied stress up to 300 MPa [2]. The variations of the critical current density j_c with the applied axial strain ϵ_f , have been investigated thoroughly, and can be described with scaling laws [3],[4]. The effect of transverse stress on the critical current of multi-filamentary

Nb₃Sn wires has also been investigated recently [5],[6]. However, when looking at transverse compression in Rutherford-type Nb₃Sn cables a larger degradation is observed. Several experiments have been done to investigate this degradation, both on bare, soldered and impregnated cables [2],[7],[8]. From these experiments it was observed that the reduction in the critical current strongly depends on the geometry of the cable and whether or not the cable is filled with epoxy or solder. In the case of a bare cable all the transverse stress is concentrated at the points where the strands cross each other, thus creating local stress concentrations, whereas in the case of a soldered or epoxy-impregnated cable a large portion of the force is transmitted through the filling material, thus creating a much more uniform stress distribution.

This paper gives a brief description of the measurement setup. Next the results of the measurements of the critical current versus applied transverse load are presented, followed by a possible explanation for the difference between the two cables. Finally, a SEM analysis of the cable before and after compression is presented, showing significant permanent damage to the superconducting strands.

II. EXPERIMENTAL SETUP

The experiments on the two samples were performed using the cryogenic pressure test facility of the Applied Superconductivity Center of the University of Twente in the Netherlands. This facility is designed to measure critical current versus magnetic field and perpendicular pressure for currents up to 50 kA in a background field up to 11 T under compressive force up to 250 kN. For the size of the pressure block used, this corresponds to a compressive stress up to 350 MPa. A schematic view of the mounted sample is shown in fig.1. The sample with a length of about 70 cm is bent in a U-shape and inserted in an 11 tesla solenoid with 80 mm bore. The sample has a section perpendicular to the magnetic field of 55 mm. In this section a compressive force is applied over a length of 40 mm. This force is generated by a set of two superconducting coils repelling each other, and transferred to the cable via a replaceable pressure block, which is adapted to the dimensions and keystone angle of the samples. By controlling the current through these coils and measuring the displacement of the set the force on the sample can be deduced. A more detailed description of the system can be found in references [2] and [9].

This work was supported by the Director, Office of Energy Research, Office of High Energy and Nuclear Physics, High Energy Physics Division, U.S. Department of Energy, under contract No. DE-AC03-76SF0098.

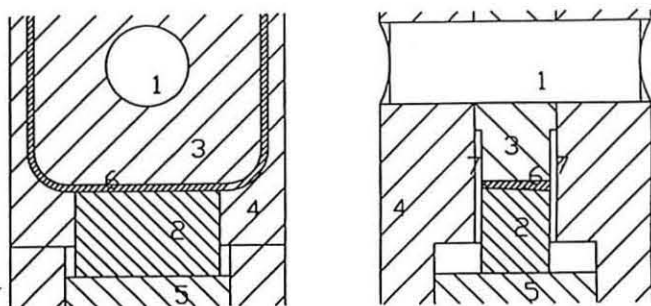

1 Lock pin 4 Press mount 7 Alignment plates
2 Pressure block 5 Push pin
3 Sampleholder 6 Cable sample

Fig. 1. Cross section of the sample mounted in the cable press.

The current through the sample is generated by a superconducting transformer circuit [10],[11]. The maximum current through the sample is about 50 kA and the accuracy of the current measurement is within 1%. The compressive force on the sample is calculated from the current through the pressure coils and is corrected for the additional field of the 11 T solenoid.

Two samples were prepared of different TWCA MJR strand material. The first cable (I) has 48 strands, dimension 15.8x1.070/1.290 mm² and a keystone angle of 0.8°, and is made of 0.65 mm diameter wire. The second cable has 26 strands, dimension 17.0x2.212/2.508 mm² and a keystone angle of 1.0° and is made of 1.29 mm wire. The number of elements per strand is 6 for sample I and 36 for sample II. Fig. 2 shows a cross-section of the two strands. The cables were used in a preliminary design, since modified, of a 13 T accelerator dipole magnet currently under construction [1].

48 STRAND CABLE
6 ELEMENTS

26 STRAND CABLE
36 ELEMENTS

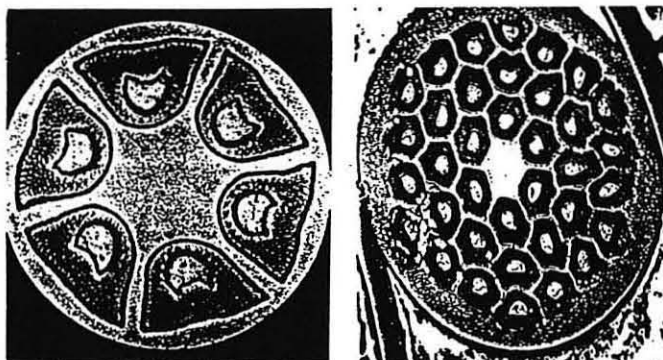

Fig. 2a. Cross section strand of sample I. b. Cross section strand of sample II.

Both samples are prepared using the same method. A short piece of the cable is bent in a U-shape and clamped on a stainless steel reaction holder. The sample holder is then cleaned and encapsulated in a glass tube. The tube is flushed with argon and evacuated, then filled with argon. Next the sample is reacted. For the heat treatment a reduced scheme has been used, which seems to result in a slightly higher current density according to tests done at BNL [12]. The reaction time at 650°C has been shortened to 48 hours. After reaction the samples were sent to the Applied Superconductivity Center at

the UT for testing. There they were impregnated with Stycast 2850FT epoxy after several voltage taps were connected at different positions on the same strands. Two different types of strands can be distinguished here, strands that run straight in the compressed area, and strands that fold around the edge of the cable under the pressure block. For the last type a separation has to be made between strands folding at the small side of the cable and strands folding at the wide side. Strands on the small side are likely to show more degradation due to the keystone of the cable. The pressure blocks are shaped to accommodate for the different keystone angles of the two samples.

III. RESULTS

The voltage current characteristics of the 26 strand sample at various pressures and B=11 T are shown in fig. 3. The curves show little difference between the several strands, thus only one strand is plotted for each pressure. Voltages up to 16 μV are measured over the strands before a quench occurs.

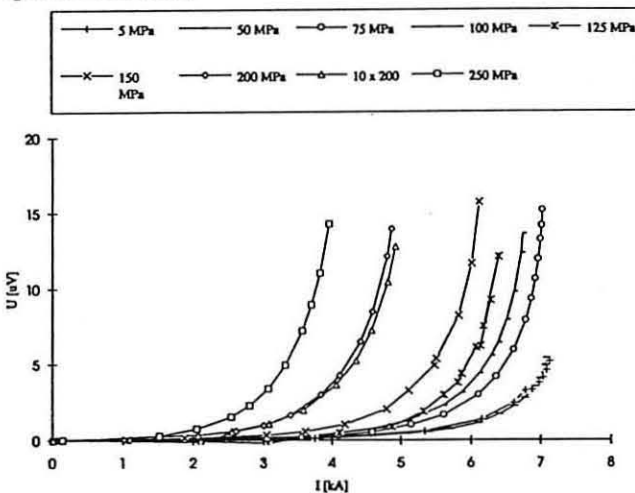

Fig. 3. Voltage current characteristics for the 26 strand sample.

The voltage current curves are recorded at several values for the applied transverse pressure while the field is varied between 5 and 11 tesla, and quench currents are recorded for fields down to 2 tesla. This allows the extrapolation to higher fields using a scaling law [3] for $F_1 - I_c B$ given by

$$F_1 - I_c B = A \left(\frac{B}{B_{c2}} \right)^p \left(1 - \frac{B}{B_{c2}} \right)^q \quad (1)$$

where F_1 is the Lorentz force, I_c the critical current, B the applied magnetic field, B_{c2} the upper critical field and A, p and q fit parameters. The curves were corrected for the self-field produced by the cable by integrating the contribution of each separate strand and adding this to the background field. The total field obtained for the side of the cable where the self-field adds to the background field is taken as the value for the magnetic field in the calculation of the fit parameters. In fig. 4 the fit curve is given for both samples against the reduced magnetic field, from which the critical current

degradation at 13 T can be deduced. Fig.5 shows the critical current and quench current versus pressure for both samples using the $\rho = 10^{-13} \Omega\text{m}$ and $\rho = 10^{-14} \Omega\text{m}$ criteria. It can be seen that sample I shows a more pronounced degradation in critical current than sample II. Also the threshold point where the degradation becomes irreversible is lower for the 48 strand cable. Irreversibility starts at about 50 MPa for the 26 strand cable, and at about 20 MPa for the 48 strand cable. Moreover, for the 48 strand cable, the critical current after the cable has been compressed to 200 MPa only reaches 68% of its original value, whereas it returns to 90% for the 26 strand cable. The top curve shows the permanent degradation of I_c .

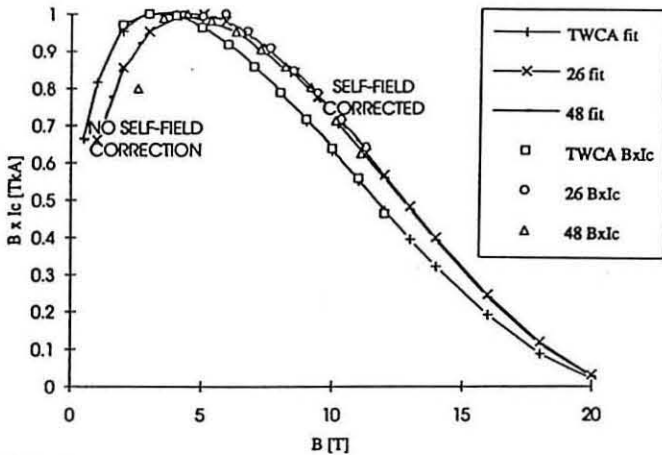

Fig.4. Fit curves for both the samples.

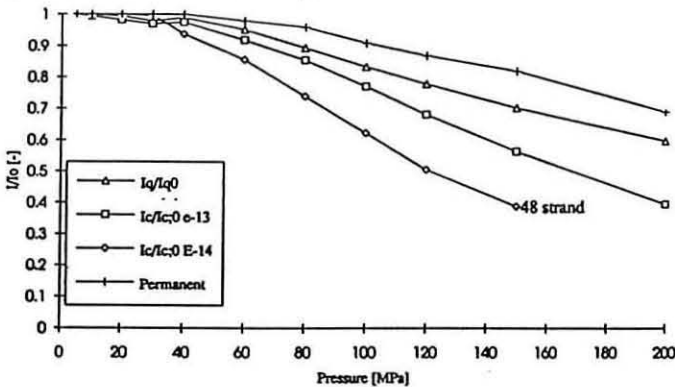

Fig.5.a. Reduction of the critical - and quench current as a function of the applied pressure, 48 strand cable

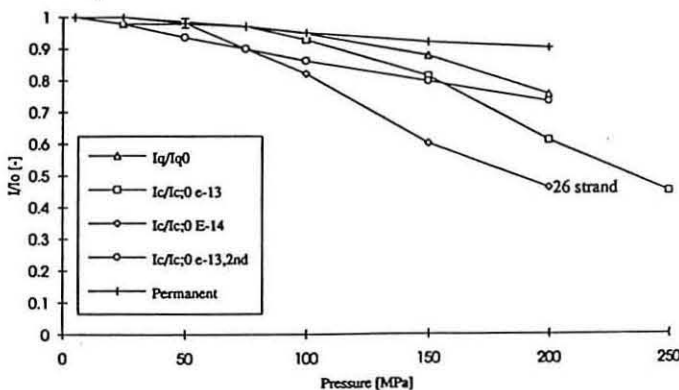

Fig.5.b. 26 strand cable

When the pressure is increased to 200 MPa the $\rho = 10^{-14} \Omega\text{m}$ criteria cannot be used for the 48 strand cable, since the initial section already shows a resistive behaviour. This causes the corresponding line for $\rho = 10^{-14} \Omega\text{m}$ to intersect at a very small angle, resulting in a large error in the determination of the critical current. The critical current reduction is about 44% for the 48 strand sample and 20% for the 26 strand cable at 150 MPa using the $\rho = 10^{-13} \Omega\text{m}$ criteria. The reduction in the 26 strand cable is found to be in good agreement with results found earlier on impregnated Nb_3Sn cables [2],[4], however, the permanent damage done to the cable starts at significantly lower stress levels. Fig.6 shows a comparison of the data obtained in these experiments with literature.

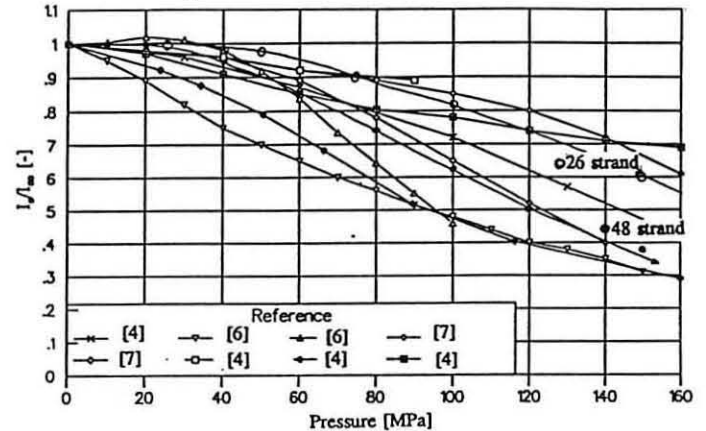

Fig.6. Experimental data compared with literature.

A second 26 strands sample has been prepared and tested at the University of Twente using the same preparation method and reaction scheme. This test was performed to verify the large degradation was not due to shipping or other causes, or due to a difference in the sample preparation. In this test, the cable was impregnated in between two thin sheets of G10 to prevent to bare cable from touching the stainless steel pressure block and sample holder. The idea behind this is to reduce the amount of stress concentrations on the cable, which could result in less critical current degradation and permanent damage. This situation also represents the real case better, where the cable will be wrapped in insulating glass-mica tape before impregnation. This sample shows a more linear degradation, but a similar recovery after releasing the pressure. The degradation at 200 MPa is less than found in the bare sample.

IV. MICROANALYSIS OF THE STRAND DAMAGE

To investigate the possible cause of the permanent degradation of the critical current, the samples were investigated using a Scanning electron Microscope (SEM). Fig.7 and 8 show the damage done to the strands after the samples have been compressed to 250 MPa. A possible explanation for the difference in reduction of the critical current for the two samples can be found in the difference of the conductors used. For the 48 strand cable, a conductor with 6 large elements was used, whereas the 26 strand cable was made of wire with 36 elements. It is likely that the larger elements will crack sooner than the thinner elements due to the fact that the deformation in the elements due to the cabling is larger.

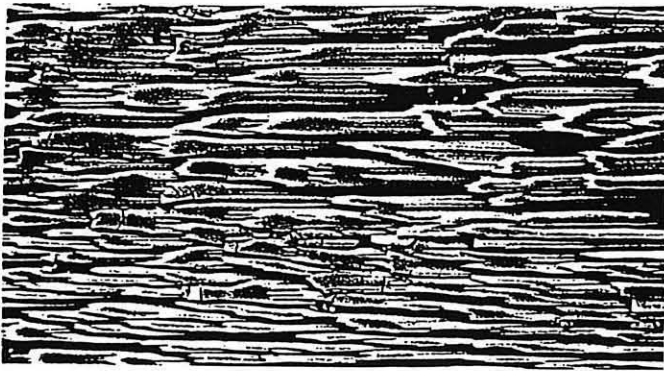

Fig.7. Damage to the strands of the 26 strands cable.

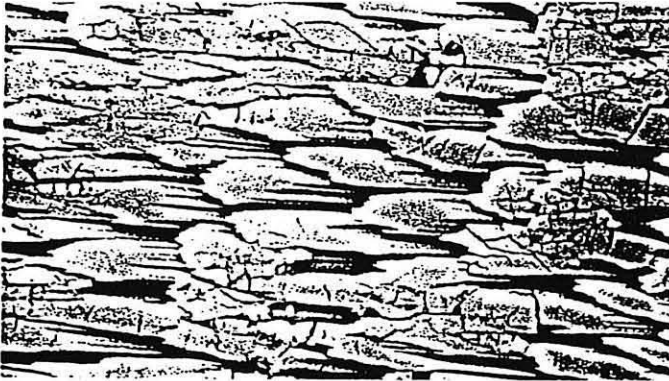

Fig.8. Damage to the strands of the 48 strands cable.

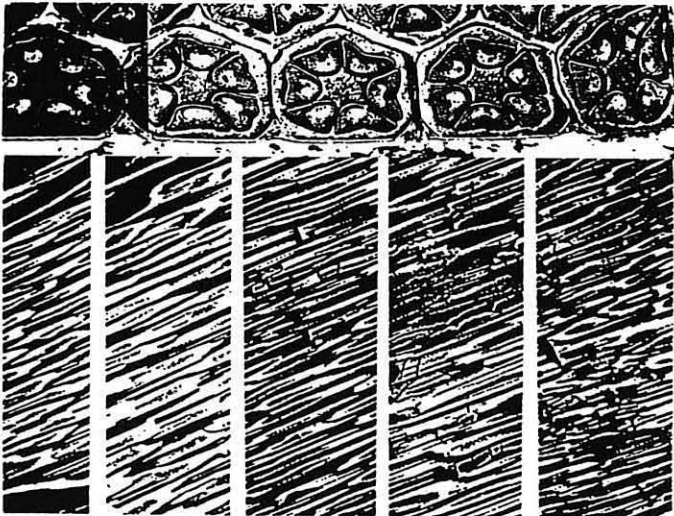

Fig.9. Damage to the thin edge of the keystone cable.

In fig. 9 the thin edge area of the cable is shown, where the compaction is the largest. Most of the visible damage to the strands can be found in this region.

V. DISCUSSION AND CONCLUSIONS

The number of experiments done on this kind of cables is still very limited, and it is difficult to make a comparison due to the differences in geometry of the cables, and whether the cable is keystone or rectangular. Also, the influence of the material used to compress the cable has to be investigated. In case of the experiments done here the cable

was compressed between two flat stainless steel plates, and a verification test was done with the cable clamped between thin G10 sheets. The difference between the first test without sheets and the second test with the sheets is too small to account for all the degradation, thus leading to the conclusion that the permanent damage in the thinner edge of the cable is causing the large permanent degradation in the critical current. This means that the keystone angle has to be kept small enough to prevent large stress concentrations in that area. An experiment to study the dependency of the critical current degradation on the keystone angle is planned in the near future.

REFERENCES

- [1] D. Dell'Orco, R. Scanlan and C.E. Taylor, "Design of the Nb₃Sn dipole D20", paper LD6, submitted to the ASC 92, Chicago, 1992.
- [2] H.Boschman, A.P.Verweij, S.Wessel, H.H.J.ten Kate and L.J.M. van de Klundert, "The effect of transverse loads up to 300 MPa on the critical currents of Nb₃Sn cables", *IEEE Transactions on Magnetics*, vol. 27, no. 2, pp.1831-1834, March 1991.
- [3] J.W. Ekin, "Four-dimensional *J-B-T-e* critical surface for superconductors", *Journal of Applied Physics*, vol. 54, no. 1, pp. 303-306, January 1983.
- [4] J.W. Ekin, "Effect of transverse compressive stress on the critical current and upper critical field of Nb₃Sn", *Journal of Applied Physics*, vol. 62, no. 12, pp. 4829-4834, December 1987.
- [5] H. Boschman, L.J.M. van de Klundert, "Effects of transverse stress on the current carrying capacity of multifilamentary wires", *Adv. Cryogenic Eng.*, vol. 36A, pp. 93-100, 1990.
- [6] W. Specking, W. Goldacker and R. Flukiger, "Effect of transverse compression on I_c of Nb₃Sn multifilamentary wire", *Adv. Cryogenic Eng.*, vol. 34, pp. 569-575, 1989.
- [7] B. Jakob and G. Pasztor, "Effect of transverse compressive stress on the critical current of cabled Nb₃Sn conductor", *IEEE Trans. on Magn.*, MAG-25, 1989, pp. 2379-2381.
- [8] H.W. Weijers, "Degradatie van de kritieke stroom van Nb₃Sn kabels door transversale druk tot 200 MPa in magneetvelden van 9-11 T", University of Twente, Enschede, The Netherlands, M.S. Thesis, 1991.
- [9] A.P. Verweij, "De invloed van transversale druk op de spanning-stroom karakteristiek van Nb₃Sn-kabels tot 340 MPa en tot 11 T", University of Twente, Enschede, The Netherlands, M.S. Thesis, 1990.
- [10] G.B.J. Mulder, H.H.J. ten Kate, H.J.G. Krooshoop, L.J.M. van de Klundert, "On the inductive method for maximum current testing of superconducting cables", *Proc. MT-11*, Tsukuba, Japan, 1989, pp. 479-484.
- [11] H.H.J. ten Kate, B. ten Haken, S. Wessel, J.A. Eikelboom and E.M. Hornsveld, "Critical current measurements of prototype cables for the CERN LHC up to 50 kA and between 7 and 13 tesla using a superconducting transformer circuit", *Proc. MT-11*, Tsukuba, Japan, 1989, pp. 60-65.
- [12] W.B.Sampson, memorandum to D.B.Smathers, TWCA, jan.18, 1990.