

Lawrence Berkeley National Laboratory

Lawrence Berkeley National Laboratory

Title

Analysis and Practices of Energy Benchmarking for Industry from the Perspective of Systems Engineering

Permalink

<https://escholarship.org/uc/item/4tf5n9vr>

Author

Ke, Jing

Publication Date

2013-06-01

DOI

<http://dx.doi.org/10.1016/j.energy.2013.>

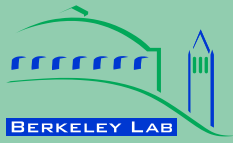

ERNEST ORLANDO LAWRENCE
BERKELEY NATIONAL LABORATORY

Analysis and Practices of Energy Benchmarking for Industry from the Perspective of Systems Engineering

**Jing Ke, Lynn Price, Michael McNeil, Nina Zheng Khanna,
Nan Zhou**

Environmental Energy Technologies Division
Lawrence Berkeley National Laboratory

***Reprint version of journal article published in “Energy”, Volume
54, Pages 32–44, June 2013***

March 2013

This work was supported by the China Sustainable Energy Program of the Energy Foundation through the U.S. Department of Energy under Contract No. DE-AC02-05CH11231.

Disclaimer

This document was prepared as an account of work sponsored by the United States Government. While this document is believed to contain correct information, neither the United States Government nor any agency thereof, nor The Regents of the University of California, nor any of their employees, makes any warranty, express or implied, or assumes any legal responsibility for the accuracy, completeness, or usefulness of any information, apparatus, product, or process disclosed, or represents that its use would not infringe privately owned rights. Reference herein to any specific commercial product, process, or service by its trade name, trademark, manufacturer, or otherwise, does not necessarily constitute or imply its endorsement, recommendation, or favoring by the United States Government or any agency thereof, or The Regents of the University of California. The views and opinions of authors expressed herein do not necessarily state or reflect those of the United States Government or any agency thereof, or The Regents of the University of California.

Ernest Orlando Lawrence Berkeley National Laboratory is an equal opportunity employer.

NOTICE: this is the author’s version of a work that was accepted for publication in Energy. Changes resulting from the publishing process, such as peer review, editing, corrections, structural formatting, and other quality control mechanisms may not be reflected in this document. Changes may have been made to this work since it was submitted for publication. A definitive version was subsequently published in Energy, Volume 54, Pages 32–44, June 2013.

Analysis and Practices of Energy Benchmarking for Industry from the Perspective of Systems Engineering

Jing Ke, Lynn Price, Michael McNeil, Nina Zheng Khanna, Nan Zhou

Environmental Energy Technologies Division
Lawrence Berkeley National Laboratory

Abstract

Benchmarking has been recognized to be an effective analysis methodology and management tool that helps to improve efficiency and performance in many areas for different objectives. Industrial energy benchmarking is a process of evaluating energy performance of an individual industrial plant or sector against a reference plant or sector. Energy benchmarking based on the performance of industry leaders or best practices is particularly useful for identifying energy inefficiencies in the production processes and estimating the potential for energy savings. This paper introduces industrial energy benchmarking and existing programs and practices and then provides a formal general system description of industrial energy benchmarking. Process-based energy benchmarking approach is further analyzed in detail from the perspective of systems engineering. The resulting system description and methodologies provide a general unified framework for analyzing and implementing industrial energy benchmarking. An industrial energy benchmarking prototype is analyzed to demonstrate the basic idea and practices of industrial energy benchmarking within this general system framework.

Keywords: *System analysis; Modeling; Energy performance; Energy intensity; Benchmarking; Industrial processes*

1. Introduction

Currently, industrial energy efficiency and potential are primarily analyzed through the application of energy indicators and energy benchmarking [1-11]. Energy benchmarking is useful for understanding energy use patterns, identifying inefficiencies in energy use, estimating potential for energy conservation, and designing policies to improve the energy economy. Energy benchmarking for industry is often defined as the process of measuring energy performance of an individual plant or industrial sector against a common metric that represents “standard” or “optimal” performance of a reference plant or industrial sector [7, 12, 13].

Benchmarking can also be designed to compare the energy performance of a number of plants against one another or to compare the plant against itself in different time periods or under different operating conditions. Comparing an individual plant or industrial sector against itself (i.e., itself as peer) in different periods or operational conditions is sometimes necessary, especially the following two situations: (1) the relevant information of other plants or industrial sectors is not available or insufficient due to intense competition or proprietary information, but the plant or industrial sector knows itself well and wants to evaluate its own performance in different operational conditions; (2) to evaluate the energy efficiency improvement of a plant or industrial sector. However, if more information is available, it is better to benchmark to the industry leaders to better understand how large the difference in performance is as well as what causes the differences. Benchmarking is often regarded as “the search for industry best practices that will lead to the superior performance” [12]. Energy benchmarking can also be viewed as the search for industry best practices in energy use that will lead to superior energy performance. “Only the comparison to and understanding of the best practices of industry or functional leaders will ensure superiority” [12]. Therefore, establishing targets and improving energy efficiency based on best practices is preferred and critical for improving the energy economy worldwide in terms of energy conservation and reducing emissions.

As an effective analysis methodology and management tool, benchmarking has been used in many areas for different objectives. The primary importance of industrial energy benchmarking is to help improve energy efficiency and reduce dioxide carbon emissions to protect the environment and to mitigate climate change, which may also generate important economic benefits through carbon trading and carbon taxes.

This paper generalizes and formalizes energy benchmarking from the perspective of systems engineering. This systematic general framework provides an analysis methodology and guidelines for designing and implementing industrial energy benchmarking. Because the major purpose of industry is production and industrial production usually consists of many inter-connected or related processes, this paper covers product- and process-based energy benchmarking with a focus on the more general process-based approach. This paper is organized as follows: Section 2 introduces industrial energy benchmarking and some existing programs and practices; Section 3 gives a general system description of energy benchmarking; Section 4 describes the general principle of designing and implementing energy

benchmarking from the perspective of systems engineering; Section 5 models process-based energy benchmarking in detail within the general system framework; Section 6 analyzes a process-based benchmarking prototype to demonstrate the basic idea and process of industrial energy benchmarking using best practices. Section 7 provides discussion and conclusions.

2. Overview of industrial energy benchmarking

Worldwide, energy benchmarking is well recognized to be effective in helping to improve industrial energy efficiency. An example of energy benchmarking practices is provided by the Dutch government and research institutions, which have been very active in developing and applying benchmarking methodologies to evaluate industrial energy use in the Netherlands and worldwide. The Dutch government and research institutions have developed benchmarks for understanding industrial energy consumption patterns and identifying good and best practices in order to assist in designing energy conservation and emission reduction-related policies, programs and initiatives [2, 7, 14, 15]. Benchmarking has been used for different objectives and tasks, such as establishing voluntary agreements between government and industry in Netherlands [14] and estimating potential energy savings in energy-intensive industries worldwide [2].

Industrial energy benchmarking is primarily practiced in the following two contexts, as illustrated by the examples presented below.

2.1. Evaluating an individual plant or an individual industrial sector

The first context for industrial energy benchmarking is to evaluate an individual plant or an individual industrial sector in order to (1) evaluate the energy performance of the plant or sector; (2) compare the performance of the plant or sector against the same or similar plants or sectors worldwide; and (3) estimate the potential for improving energy efficiency of the plant or sector based on best practice [16].

The petroleum refining and petrochemical industries pioneered the use of benchmarking to evaluate the performance of individual plants [7, 17]. A metric called the Energy Intensity Index (EII)¹ is employed to evaluate the energy efficiency of the industry [7, 17]. In this methodology, energy consumption standards, which include adjustment for feed quality and processing intensity, are set for each of the processes in the petroleum refining and petrochemical industries. The benchmark energy consumption is the sum of all appropriate energy standards for the plant, and EII is defined as ratio of the actual total energy consumption over the benchmark energy consumption, which is usually expressed in percentage² [7, 17].

¹ The term “Energy Efficiency Index (EEI)” is also widely used in the literature [2].

² The EII of the plant or sector that consumes the same amount of energy as the benchmark plant or sector is 100. For one specific plant or sector, the larger the EII is, the higher the energy intensity of the

ENERGY STAR is a joint energy efficiency program of the U.S. Environmental Protection Agency (EPA) and the U.S. Department of Energy (DOE) helping to improve energy efficiency and protect the environment through energy efficient products and practices [18]. The ENERGY STAR for Industry program provides guidance for effective energy management and tools to help industrial facilities evaluate and benchmark their energy performance. ENERGY STAR for Industry develops plant Energy Performance Indicators (EPIs) that are sector-specific energy benchmarking tools that compare plants to U.S. average performance for that sector [19]. The EPI provides a sector-specific ENERGY STAR score for energy efficiency on a scale of 1 to 100. This score is calculated using the annual energy and operating data of an individual plant compared to the average for similar plants in the U.S. [19]. An industrial plant that scores higher than the 75th percentile (i.e., within the top 25 percent) is regarded as energy efficient [19] and may apply for ENERGY STAR certification [20].

2.2. Setting company- or industry-wide energy efficiency goals

The second context for energy benchmarking is to set company- or industry-wide energy efficiency goals using benchmarking approaches [16]. Energy benchmarking in this context often requires first determining a baseline, which is usually set as the current energy intensity or energy performance of the company or industry, though using the past energy performance of the plant or sector is also possible. The energy efficiency goals are often expressed as the estimated potential reduction of the baseline energy intensity [16, 17, 21].

In China—now the world’s largest energy consumer—industry accounts for about 70% of the country’s energy consumption. Despite the achievements China has made in industrial energy efficiency, Chinese industry is still generally energy-intensive and inefficient compared to industry leaders worldwide. Therefore, setting energy efficiency goals for industry based on energy benchmarking against the Chinese and international advanced levels is often used in China. To some extent, reaching or approaching the Chinese or international advanced level is a general energy efficiency goal for Chinese industry, e.g., the energy efficiency goal-setting for the Top-1000 Enterprises Energy-Saving Program (Top-1000 Program) [21] and the Ten Key Energy Conservation Projects [22]. It is reported that the Top-1000 Program achieved total energy savings of about 4.40 exajoules (EJ) from 2006 to 2010 compared to a growth baseline [23]. Table 1 lists the reduction in final energy intensity of major energy-intensive products in China from 2006 to 2010.

Table 1. Reduction in final energy intensity of industrial products in China, 2006-2010.

Source: [24-26].

plant or sector is. For example, if the EII of one plant is 130, it means that the plant requires 30% more energy for the equivalent level of production or processing compared to the benchmark plant [18].

Energy intensity	2005	2006	2007	2008	2009	2010	Reduction rate by 2010 over the 2005 level (%)
Thermal power (MJ/kWh)	10.84	10.76	10.43	10.11	9.96	9.76	10.0
Steel (GJ/t) ^a	20.34	18.90	18.52	18.46	18.15	17.73	12.8
Cement (GJ/t)	3.72	3.52	3.37	3.03	2.81	2.81	24.6 ^b
Ethylene (GJ/t)	28.89	28.34	28.03	27.60	26.67	25.81	10.7
Synthetic ammonia (GJ/t)	42.58	43.45	41.80	41.80	40.75	39.75	6.6

Note: The abbreviation "t" denotes tonne. Energy intensity values listed in the table represent the average energy intensity levels of the Chinese enterprises above the designated size [25, 27]. All figures are reported or estimated according to the reported figures and care should be taken when interpreting the figures [25].

^a China adopts a conversion factor of 1 kilowatt-hour (kWh) to 3.6 megajoules (MJ) for electricity in its energy intensity calculation [25].

^b The clinker-to-cement ratio decreased from 73% in 2005 to 62% in 2010.

3. System description and analysis of energy benchmarking

The basic idea of energy benchmarking is to evaluate and compare the energy efficiency of two systems which can be as aggregate as industrial sectors or as disaggregate as specific industrial process-steps, and to identify the potential for improving energy efficiency based on the difference between the two systems. Therefore, a reference or benchmark system³ (i.e., the system against which is to be benchmarked) is necessary for energy benchmarking. Because the primary purpose of energy benchmarking is to identify inefficiencies in energy use and potential energy savings and to further improve energy efficiency based on best practices in the same or similar industries, the benchmark system should have some basic properties such as being physically realizable, highly energy-efficient, and comparable.

From the perspective of systems engineering, the basic idea of energy benchmarking can thus be generalized using the system diagram shown in Figure 1.

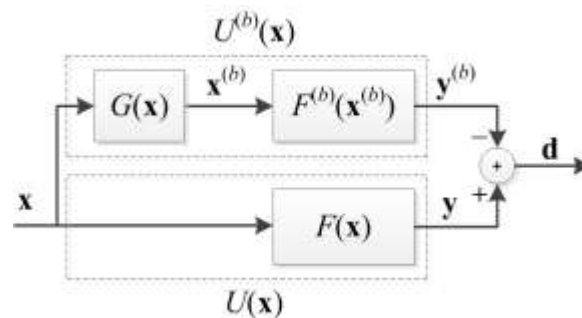

³ The benchmark system could be an existing system or a system in development or a hypothetical system.

Figure 1. System diagram of general energy benchmarking

Note: superscript ^(b) denotes the benchmark (reference) system.

The mathematical equations that describe the system shown in Figure 1 are:

$$\mathbf{y} = F(\mathbf{x}) = U(\mathbf{x}), \quad (1)$$

$$\mathbf{y}^{(b)} = F^{(b)}(\mathbf{x}^{(b)}) = F^{(b)}(G(\mathbf{x})) = U^{(b)}(\mathbf{x}), \quad (2)$$

$$\mathbf{d} = \mathbf{y} - \mathbf{y}^{(b)}, \quad (3)$$

where:

- i. $\mathbf{x} = (x_1, x_2, \dots, x_m)$ and $\mathbf{x}^{(b)} = (x_1^{(b)}, x_2^{(b)}, \dots, x_m^{(b)})$ are m -dimensional real vectors of which elements represent the energy-governing factors (e.g., material input, production volume, product type and grade, or the design of and operation of installed equipment) [28], or, more formally, control variables.
- ii. $G(\mathbf{x})$ is the function of translating the control variable \mathbf{x} to $\mathbf{x}^{(b)}$. As long as it is possible, we let benchmark system and the system to be evaluated have the same input⁴, which is denoted as $\mathbf{x}^{(b)} = \mathbf{x}$, i.e. $G(\mathbf{x}) = \mathbf{x}$. In case the system to be evaluated has different input from the benchmark system, $G(\mathbf{x})$ needs to be determined according to equivalence principle so that the two systems can be compared against each other at a reasonable basis. We note that the equivalence used to derive $G(\mathbf{x})$ depends on specific situation or application. One possible option is “functional equivalence”. For example, the benchmark system produces a high-quality and durable product A while the system to be evaluated produces a low-quality and short-life product B . Assume that producing one unit of product A requires the same amount of materials as producing one unit of product B . If one unit of the product A can replace two units of the product B for the same function and the life of the product A is two times that of the product B , one unit of product A can be regarded as functionally equivalent to four units of product B . If we further assume the amount of product is the only control variable for the two systems, i.e. $\mathbf{x} = (x)$ where x is the amount of product B produced by the system to be evaluated and $\mathbf{x}^{(b)} = (x^{(b)})$ where $x^{(b)}$ is the amount of the product A required to be produced by the benchmark system for the functional equivalence, $\mathbf{x}^{(b)} = (x^{(b)}) = G(\mathbf{x}) = 0.25 \cdot (x)$.
- iii. $\mathbf{y} = (y_1, y_2, \dots, y_n)$ and $\mathbf{y}^{(b)} = (y_1^{(b)}, y_2^{(b)}, \dots, y_n^{(b)})$ are n -dimensional real vectors of which elements represent different type of fuels (e.g., coal or natural gas) and electricity that are consumed (defined as positive number) or produced (defined as negative number) by the system and is measured in energy units (e.g., gigajoules or tonnes of oil equivalent).

⁴ It should be noted that it is very rare that two real industrial systems (e.g., plants or sectors) have homogeneous energy-governing factors [22]. However, in many cases, we can identify some major equivalent energy-governing factors for different industrial systems, especially when the benchmark system is modeled as a hypothetical system (e.g., a hypothetical plant modeled using best practices) which can have the same control variables as the system to be evaluated.

- iv. $\mathbf{y} = F(\mathbf{x})$ and $\mathbf{y}^{(b)} = F^{(b)}(\mathbf{x}^{(b)})$ is the mathematical energy model of the system of which energy efficiency is to be evaluated and the benchmark system, respectively;
- v. $\mathbf{d} = (d_1, d_2, \dots, d_n) = (y_1 - y_1^{(b)}, y_2 - y_2^{(b)}, \dots, y_n - y_n^{(b)})$ is an n -dimensional real vector of which each element (i.e., $d_i = y_i - y_i^{(b)}$, $i = 1, 2, \dots, n$) represents the difference in consumption or generation of one type of fuel or electricity between the system to be evaluated and the benchmark system.
- vi. $U(\mathbf{x}) = F(\mathbf{x})$; $U^{(b)}(\mathbf{x}) = F^{(b)}(G(\mathbf{x}))$ is a composite function.

Industrial production, especially heavy industry (e.g., iron and steel, chemicals, cement), consumes a large amount of energy. However, an industrial plant may also produce secondary energy (e.g. electricity) while consuming primary energy such as coal or natural gas. For example, a cement plant equipped with waste heat recovery power generation may produce electricity for its own use or to sell to the grid, even though it is consuming a large amount of fuels such as coal. In order to evaluate the overall energy efficiency of the plant, the total energy consumption E is defined as

$$E = \sum_{i=1}^n w_i y_i, \quad (4)$$

where w_i for any $i = 1, 2, \dots, n$, denotes the conversion factor of each type of fuel or electricity that is consumed or produced by the system and is measured in energy units. In industrial practices, if different types of fuels and electricity are directly summed up using the concept of energy equivalent (e.g., heat value equivalent) without accounting for energy conversion or transformation process, the resulting total energy consumption is usually called final energy consumption; if the energy conversion or transformation losses are accounted for, the resulting total energy consumption is usually called primary energy consumption. The calculation of final and primary energy consumption can be expressed explicitly by assigning different conversion factors to each type of fuel or electricity corresponding to energy conversion or transformation losses.

Similarly, the total benchmark energy consumption $E^{(b)}$ can be defined as

$$E^{(b)} = \sum_{i=1}^n w_i y_i^{(b)}. \quad (5)$$

Total energy consumption is often used for evaluating the overall energy performance as it is inconvenient to compare vectors \mathbf{y} and $\mathbf{y}^{(b)}$ directly.

Under the above assumptions and conditions, the often-used energy benchmarking can be simplified to the diagram shown in Figure 2.

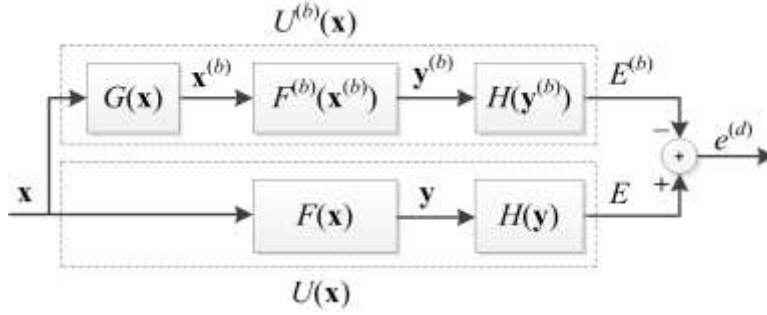

Figure 2. System diagram of simplified energy benchmarking

Note: superscript “ (b) ” denotes the benchmark (reference) system.

The mathematical equations that describe the system shown in Figure 2 are:

$$E = H(\mathbf{y}) = H(F(\mathbf{x})) = U(\mathbf{x}), \quad (6)$$

$$E^{(b)} = H(\mathbf{y}^{(b)}) = H(F^{(b)}(\mathbf{x}^{(b)})) = H(F^{(b)}(G(\mathbf{x}))) = U^{(b)}(\mathbf{x}), \quad (7)$$

$$e^{(d)} = E - E^{(b)}. \quad (8)$$

Where:

- i. Control variables $\mathbf{x} = (x_1, x_2, \dots, x_m)$ and $\mathbf{x}^{(b)} = (x_1^{(b)}, x_2^{(b)}, \dots, x_m^{(b)})$ are m -dimensional real vectors of which elements represent the energy-governing factors. $G(\mathbf{x})$ is the function of translating the control variable \mathbf{x} to $\mathbf{x}^{(b)}$.
- ii. \mathbf{y} and $\mathbf{y}^{(b)}$ are real vectors of which elements represent the different types of fuels and electricity that are consumed (defined as positive number) or produced (defined as negative number) by the system. $H(\cdot)$ is the function of calculating total energy consumption expressed by Equations (4) and (5).
- iii. E denotes the total energy consumption for the system to be evaluated and $E^{(b)}$ denotes the total energy consumption for the benchmark system.
- iv. The difference between E and $E^{(b)}$, i.e., $e^{(d)} = E - E^{(b)}$, reflects the difference in energy performance between the two systems: a positive $e^{(d)}$ indicates that the system to be evaluated is not as energy-efficient as the benchmark system and $e^{(d)}$ can be regarded the potential for energy savings; a negative $e^{(d)}$ indicates that the system to be evaluated is more energy-efficient than the benchmark system; a zero of $e^{(d)}$ indicates that the energy efficiencies of the two systems are same.
- v. $U(\mathbf{x}) = H(F(\mathbf{x}))$ and $U^{(b)}(\mathbf{x}) = H(F^{(b)}(G(\mathbf{x})))$ are two composite functions that describe the energy model of the systems. We note that, if the purpose of energy benchmarking is to evaluate the overall energy performance and the consumption or production of different types of fuels or electricity are not needed to be reported separately, it is often convenient to model $U(\mathbf{x})$ and $U^{(b)}(\mathbf{x})$ directly instead of modeling them as composite functions.

The above system description provides a general and formal framework for analyzing and implementing energy benchmarking.

4. Designing and implementing industrial energy benchmarking from the perspective of systems engineering methodology

It is ideal to design and implement energy benchmarking following a systems engineering methodology, especially for complicated industrial systems.

Industrial production usually consists of a number of processes (or stages) and each process can usually be further divided into a number of detailed process-steps. Different processes may have very different energy use and efficiency characteristics. In implementing effective energy benchmarking that accounts for production differences, it is necessary to look inside the production processes and take into account the various process used [7, 16].

The resulting energy benchmarking can be called process or process-step energy benchmarking [7, 16], depending on the definition of the process or process-steps. In this paper, we use process blocks to describe relatively aggregate sub-processes, and process-steps for disaggregated sub-processes within a process block. In other words, the production process of a plant is divided into a number of general process blocks and each process block is further divided into a number of specific process-steps⁵. The processes can then be analyzed at different levels to provide different levels of results and insights for understanding the energy performance of industrial production. From the perspective of systems engineering, this kind of process disaggregation and multi-level analysis can be viewed as top-down system decomposition and modular analysis of which the idea is illustrated in Figure 3. More formally, one process at level L is decomposed into a number of sub-processes at level $L-1$, which means one level lower than L , and each sub-process at level $L-1$ can be further decomposed into a number of sub-processes at level $L-2$.

⁵ The determination of process-blocks and process-steps depends on specific industrial production and how detailed the benchmark analysis needs to be. A process-block does not necessarily include more than one process-step.

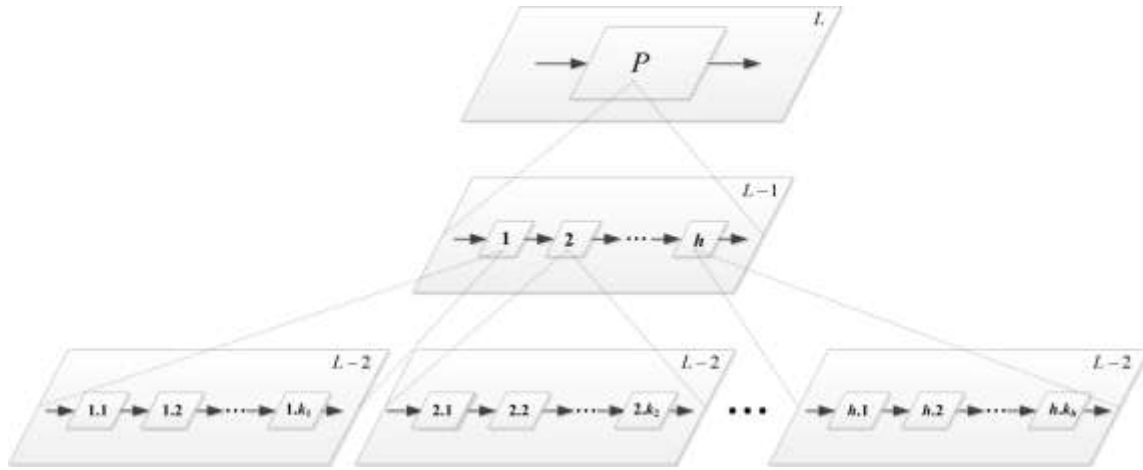

Figure 3. Top-down decomposition and modular analysis of production process

Generally speaking, the process-based energy benchmarking approaches involve two key procedures: identifying the key energy-consuming sub-processes for an industrial process and evaluating the performance of an industrial process at each of these key sub-processes [7, 16]. From the perspective of systems engineering [29, 30], the implementation of process-based energy benchmarking usually involves the following steps: system analysis, system modeling, system evaluation, and decision support. These steps are briefly described as follows.

4.1. System analysis – analyzing and decomposing the industrial processes

The process-based energy benchmarking approach begins with an understanding of the production processes used in the evaluated industry [16]. One key point in this step is to analyze the production pathways and identify the key energy-intensive sub-processes. Production pathways can generally be classified into three categories: from raw materials to intermediate products, from one intermediate product to another intermediate product, and from intermediate products to final products [16]. Often, there are a number of pathways that lead to the production of one central intermediate product (e.g., clinker production in cement industry) which usually encompasses the most energy-intensive sub-processes [16, 31]. There are then more pathways that lead from the central intermediate product to a number of final products (e.g., various grades of cement). These pathways and central intermediate products usually provide useful insights on how to decompose the industrial process into sub-processes. The sub-process can be further decomposed into a number of more disaggregated sub-processes if necessary for a better and deeper understanding of the production process. We note that a good analysis of production pathways and identification of key energy-intensive sub-processes is often the critical step to correctly building the benchmarking models.

4.2. System modeling – building the system model for energy benchmarking

This step usually involves the following tasks: setting boundaries of the analysis; defining the benchmark energy categories; building mathematical models for energy performance comparison and determining benchmarks. Setting boundaries of the analysis is the selection of sub-processes to be included in the benchmarking analysis. The most energy-intensive sub-processes should always be included. In benchmarking practices, the sub-processes in the analysis boundary are expected to have some sort of measureable physical output that can be used as the basis of an intensity measure [16]. Defining the benchmark energy categories is mainly related to the selection of energy sources in the benchmarking analysis and final or primary energy considerations. The industrial system modeling procedure is closely related to the individual industrial process, data availability, and required accuracy of the analysis. In industrial energy benchmarking practices, energy intensity-based models are often used due to their simplicity and acceptable accuracy. Benchmarks are required to set up the parameters of the benchmark system. For energy intensity-based methodologies, determining the benchmarks consists primarily of establishing the benchmark intensities for each of the sub-processes [16].

4.3. System evaluation – evaluating the energy performance of the industrial process

The energy performance of the industrial process is measured at each sub-process against the corresponding benchmark sub-process, i.e., making sub-process-specific comparisons between the energy used for each sub-process and that used for benchmark sub-process developed according to predetermined benchmark values [7, 16]. Energy-inefficient sub-processes are often identified in this step and the potential for energy savings of each sub-process can also be estimated. The overall energy performance of the process can be evaluated by aggregating the energy performance of all sub-processes. We note that energy performance comparisons and evaluations become complicated when multiple energy sources are involved in the process or sub-processes, especially when secondary energy such as electricity is involved.

4.4. Decision support – potential and cost-benefit analysis for energy efficiency improvement

The main purpose of process-based energy benchmarking is to identify the primary gaps in energy efficiency, how large the potential is, and how to improve energy efficiency at affordable cost. To support decision-making, a detailed analysis of the potential for energy-efficiency improvement as well as the costs and benefits of implementing energy efficiency measures is often needed. To be more specific, energy-efficient technologies and measures that could be implemented to improve the energy efficiency of the process or sub-process need to be evaluated, and the potential for improving energy

efficiency is estimated by calculating the energy savings that will result from adoption of these energy-efficiency technologies and measures [7, 32]. The costs and benefits of adopting these technologies and measures are estimated to support making reasonable and cost-effective decisions. The overall improvement in energy efficiency of the whole process should also be given to provide a general image of the effectiveness of adopting the energy-efficiency technologies and measures, which can be viewed as setting up a new hypothetical plant by using the energy-efficiency technologies and measures and then comparing this new hypothetical plant with the benchmark plant [7, 32].

We note that a product-based approach is also often used when the process information is not available or insufficient.

The basic idea and assumption behind product-based energy benchmarking is that the energy consumption of making one type and grade of product can be calculated by multiplying the throughput of that product by the energy intensity of making that product. These energy consumption values are then summed across all products to give the total energy consumption for the plant or sector to be evaluated and benchmark plant or sector [2, 7, 16].

Product-based energy benchmarking at the plant or sector level provides some general understanding of the energy efficiency of the plant or sector to be evaluated, which helps to determine the gap between the plant or sector to be evaluated and the benchmark systems and to estimate the overall potential for energy efficiency improvement. However, energy benchmarking as a whole at the plant or sector level usually does not help determine why the gap exists and where the potential is and how to effectively and significantly improve energy efficiency.

We note that if one industrial plant or sector is modeled as one process and making specific final products (commodities) are modeled as sub-processes, or in other words, the making of one specific final product (commodity) is modeled as one production sub-process of the plant or sector, product-based energy benchmarking at the plant or sector level can be viewed as a particular case of the process-based energy benchmarking.

5. System analysis of process-based energy benchmarking

The formal system description of the process-based energy benchmarking is given for analyzing the industrial energy benchmarking theoretically and systematically.

Given one specific process P that is composed of h sub-processes, denoted as $P = \{p_1, p_2, \dots, p_h\}$, the process-based energy benchmarking can be described by the diagram shown in Figure 4.

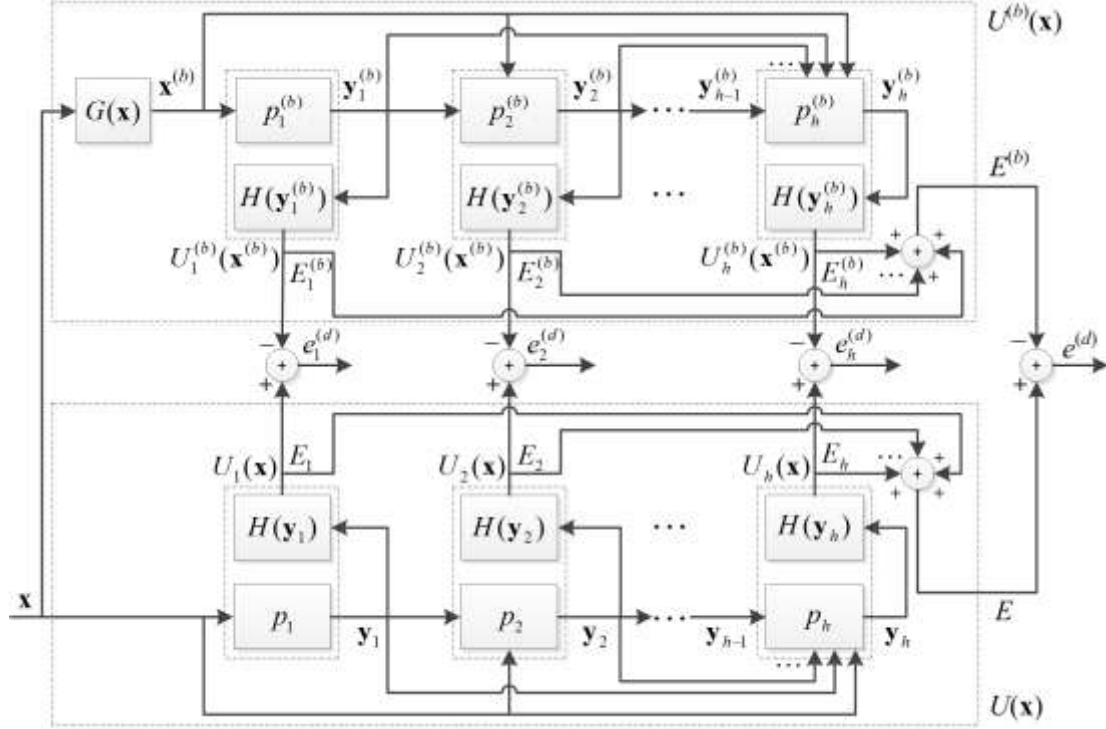

Figure 4. System diagram of process-based energy benchmarking

Note: superscript ^(b) denotes the benchmark (reference) system.

The mathematical equations that describe the system shown in Figure 4 are:

$$\mathbf{y}_1 = p_1(\mathbf{x}), \quad (9)$$

$$\mathbf{y}_i = p_i(\mathbf{x}, \mathbf{y}_1, \mathbf{y}_2, \dots, \mathbf{y}_{i-1}) \text{ for any } i = 2, 3, \dots, h, \quad (10)$$

$$\mathbf{y}_1^{(b)} = p_1^{(b)}(G(\mathbf{x})), \quad (11)$$

$$\mathbf{y}_i^{(b)} = p_i^{(b)}(G(\mathbf{x}), \mathbf{y}_1^{(b)}, \mathbf{y}_2^{(b)}, \dots, \mathbf{y}_{i-1}^{(b)}) \text{ for any } i = 2, 3, \dots, h, \quad (12)$$

$$E_i = H(\mathbf{y}_i) \text{ for any } i = 1, 2, \dots, h, \quad (13)$$

$$E_i^{(b)} = H(\mathbf{y}_i^{(b)}) \text{ for any } i = 1, 2, \dots, h, \quad (14)$$

$$e_i^{(d)} = E_i - E_i^{(b)} \text{ for any } i = 1, 2, \dots, h, \quad (15)$$

$$E = E_1 + E_2 + \dots + E_h, \quad (16)$$

$$E^{(b)} = E_1^{(b)} + E_2^{(b)} + \dots + E_h^{(b)}, \quad (17)$$

$$e^{(d)} = E - E^{(b)}. \quad (18)$$

The actual energy consumption of each sub-process, i.e., E_i for any $i = 1, 2, \dots, h$, and total energy consumption E of process P can usually be measured directly or calculated according to Equations (13) and (16), respectively. The difference between E_i and $E_i^{(b)}$, i.e., $e_i^{(d)} = E_i - E_i^{(b)}$ for any $i = 1, 2, \dots, h$, can be used to evaluate the difference in energy performance of the i th sub-process p_i : a positive $e_i^{(d)}$ means the sub-process to be evaluated consumes more energy than the benchmark sub-process for the

equivalent level of production or processing; and a negative $e_i^{(d)}$ means the sub-process to be evaluated is more efficient than benchmark sub-process⁶. If $e_i^{(d)}$ is positive, it is often regarded as the potential for energy savings of the sub-process to be evaluated. The difference between total energy consumption E and $E^{(b)}$, i.e., $e^{(d)} = E - E^{(b)}$, can be used to evaluate the difference in overall energy performance of process P .

We note that the above process energy benchmarking is a particular case of the system description of energy benchmarking shown in Figure 2. More specifically, this can be verified by defining:

$$U(\mathbf{x}) = \sum_{i=1}^h E_i = \sum_{i=1}^h H(\mathbf{y}_i) = H(p_1(\mathbf{x})) + \left(\sum_{i=2}^h H(p_i(\mathbf{x}, \mathbf{y}_1, \mathbf{y}_2, \dots, \mathbf{y}_{i-1})) \right), \quad (19)$$

$$U^{(b)}(\mathbf{x}) = \sum_{i=1}^h E_i^{(b)} = \sum_{i=1}^h H(\mathbf{y}_i^{(b)}) = H(p_1^{(b)}(G(\mathbf{x}))) + \left(\sum_{i=2}^h H(p_i^{(b)}(G(\mathbf{x}), \mathbf{y}_1^{(b)}, \mathbf{y}_2^{(b)}, \dots, \mathbf{y}_{i-1}^{(b)})) \right), \quad (20)$$

where \mathbf{y}_i and $\mathbf{y}_i^{(b)}$ for any $i=1,2,\dots,h$, are defined by Equations (9) to (12) and are all composite functions⁷ of vector \mathbf{x} of which elements are input variables.

In industrial energy benchmarking practices, energy intensity is often used as a metric that is irrespective of process scale or production volume. Specifically, the energy consumption of the process to be evaluated and benchmark process can be defined as:

$$E = \sum_{i=1}^h O_i \cdot V_i, \quad (21)$$

$$E^{(b)} = \sum_{i=1}^h O_i \cdot V_i^{(b)}, \quad (22)$$

where: O_i for any $i=1,2,\dots,n_p$, denotes the output (e.g., prepared raw materials, intermediate products or final products) of the i th sub-process; V_i and $V_i^{(b)}$ denotes the energy intensity of the sub-process to be evaluated and benchmark sub-process, respectively.

The above system description provides a general framework to analyze and design the process-based energy benchmarking.

The concept of EII (Energy Intensity Index) is also often used in process-based energy benchmarking. Specifically, according to Equations (21) and (22), the EII of the process can be defined as:

$$\text{EII} = 100 * \frac{E}{E^{(b)}} = 100 * \frac{\sum_{i=1}^h O_i \cdot V_i}{\sum_{i=1}^h O_i \cdot V_i^{(b)}}. \quad (23)$$

⁶ The benchmark system may be the process or sub-process itself in a past period, and the resulting benchmark indicates the past performance of the process or sub-process itself.

⁷ This can be verified by expanding the expressions in Equations (10) and (12).

By incorporating the top-down decomposition of production process shown in Figure 3, the definition of EII described by Equation (23) can be generalized to any specific process at any level, e.g., plant as a general process which is composed of a number of process-blocks, or a process-block which is composed of a number of process-steps.

6. An energy benchmarking prototype for cement industry

Cement is an important building material worldwide. In 2011, the world’s cement production was 3.6 billion tonnes [33]. China accounts for about 50 percent of global cement production [33, 34]. Cement production is energy-intensive and requires intense heat for the chemical combination of a mixture of raw materials [16]. Cement production also consumes a large amount of electricity for its raw material preparation and finish grinding. Furthermore, cement production is also a major CO₂ emissions source [35]. Figure 5 shows an overview of the key production processes in cement production. The importance and necessity of energy benchmarking in the cement industry is well recognized [36-39].

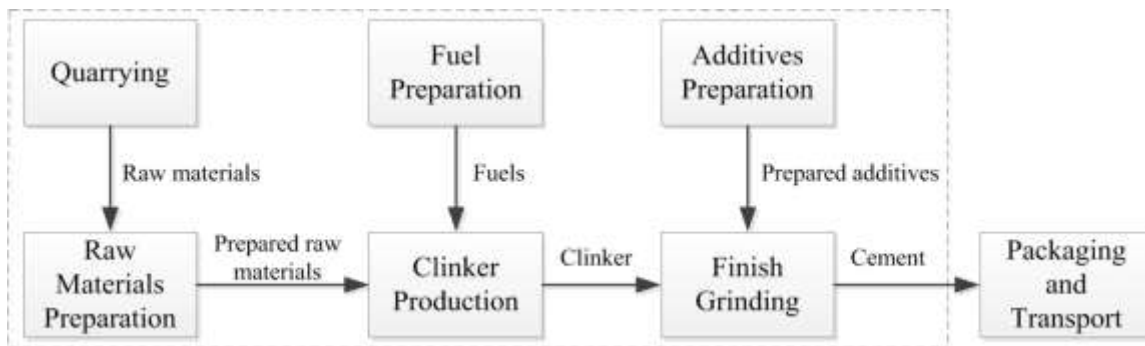

Figure 5. Overview of cement production process

Note: Dashed lines outline the processes addressed in the benchmarking prototype for cement production

To help the cement industry to evaluate and benchmark its energy efficiency and carbon emissions, a significant number of studies and tools have been developed worldwide, such as the Canadian cement industry energy benchmarking study [39, 40], the sectoral Clean Development Mechanism (CDM) benchmarking methodology developed by the Cement Sustainability Initiative (CSI) and Ecofys based on CSI’s global cement database on CO₂ and energy information (i.e., “Getting the Numbers Right”, the GNR database) [41], the cement manufacturing energy performance indicator developed by U.S. ENERGY STAR [19], the energy and carbon-based benchmarking for the cement industry in the European Union (EU) [37, 38, 42, 43], and the Benchmarking and Energy Savings Tool (BEST)-Cement developed by Lawrence Berkeley National Laboratory (LBNL) [32].

This section analyzes an energy benchmarking prototype derived from the LBNL’s BEST-Cement tool to demonstrate the process-based benchmarking approach within the general framework presented in previous sections.

The prototype provides process-based energy benchmarking at both the plant and process levels for cement production. The boundary for energy benchmarking is outlined by dashed lines in Figure 5. The prototype can benchmark the energy efficiency of a wide range of cement products. Specifically, the prototype can benchmark the energy efficiency of pure Portland cement, common Portland cement, slag cement, fly ash cement, *pozzolana* cement, and blended cement. The classification of process-blocks and process-steps is shown in Table 2. The system diagram of the process-based (process-block level) energy benchmarking is shown in Figure 6.

Table 2. Processes addressed in the prototype for benchmarking a cement facility

Process blocks	Process-steps
• (p_1) Raw materials preparation	• ($p_{1.1}$) Preblending ^a • ($p_{1.2}$) Crushing • ($p_{1.3}$) Grinding • ($p_{1.4}$) Homogenization
• (p_2) Fuel preparation	• ($p_{2.1}$) Fuel grinding and preparation
• (p_3) Additives preparation	• ($p_{3.1}$) Drying • ($p_{3.2}$) Additive grinding and blending ^b
• (p_4) Kiln system - machinery use (electricity)	• ($p_{4.1}$) Preheater & clinker cooler • ($p_{4.2}$) Precalciners & kiln
• (p_5) Kiln system - clinker making (fuel use)	• ($p_{5.1}$) Precalciners • ($p_{5.2}$) Kiln
• (p_6) Cement grinding (finish grinding)	• ($p_{6.1}$) Grinding by cement types and grades
• (p_7) Other production energy	• ($p_{7.1}$) Quarrying • ($p_{7.2}$) Auxiliaries • ($p_{7.3}$) Conveyors
• (p_8) Other non-production energy	• ($p_{8.1}$) Lighting, office equipment, miscellaneous

^a *Prehomogenization, proportioning and reclaiming.*

^b *In this analysis, the energy required by additive grinding and blending for blended cement production is included in the cement grinding (finish grinding).*

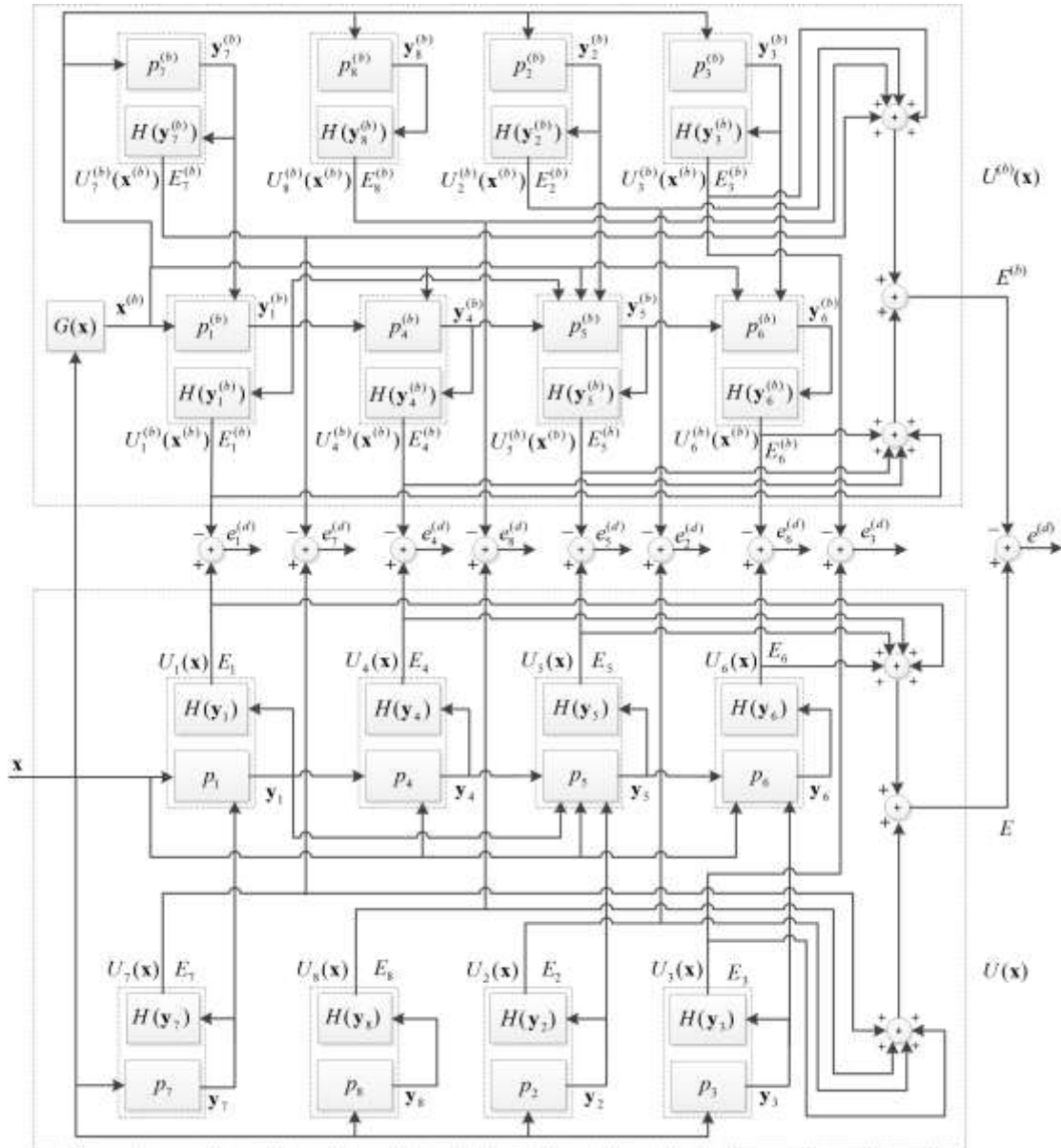

Figure 6. System diagram of process-based (process-block level) energy benchmarking in the prototype for cement production

Note: superscript ^(b) denotes the benchmark (best practice) system. The process-blocks are defined as: (p1) raw materials preparation; (p2) fuel preparation; (p3) additives preparation; (p4) kiln system - machinery use (electricity); (p5) kiln system - clinker making (fuel use); (p6) cement grinding (finish grinding); (p7) other production energy; (p8) other non-production energy. The more disaggregated process-steps are defined in Table 2.

The process control variables for the benchmarking prototype are defined as

$$\mathbf{x} = (x_1, x_2, \dots, x_{28}) \in R^{28},$$

where:

x_1 — amount of raw materials that are quarried and conveyed;

- x_2 —amount of raw materials that are preblended (i.e., prehomogenized, proportioned and reclaimed);
- x_3 —amount of raw materials that are crushed and ground;
- x_4 —amount of additives that are dried;
- x_5 —amount of blast furnace and other slags that are ground;
- x_6 —amount of fly ash that is ground;
- x_7 —amount of natural pozzolans that are ground;
- x_8 —amount of raw materials that are homogenized;
- x_9 —amount of fuels (coal) that are ground;
- x_{10} —amount of clinker produced;
- x_{11}, x_{12}, x_{13} —amount of 42.5/42.5R, 52.5/52.5R, and 62.5/62.5R pure Portland cement produced, respectively;
- x_{14}, x_{15}, x_{16} —amount of 32.5/32.5R, 42.5/42.5R, and 52.5/52.5R common Portland cement produced, respectively;
- x_{17}, x_{18}, x_{19} —amount of 32.5/32.5R, 42.5/42.5R, and 52.5/52.5R slag cement produced, respectively;
- x_{20}, x_{21}, x_{22} —amount of 32.5/32.5R, 42.5/42.5R, and 52.5/52.5R fly ash cement produced, respectively;
- x_{23}, x_{24}, x_{25} —amount of 32.5/32.5R, 42.5/42.5R, and 52.5/52.5R pozzolana cement produced, respectively;
- x_{26}, x_{27}, x_{28} —amount of 32.5/32.5R, 42.5/42.5R, and 52.5/52.5R blended limestone cement produced, respectively.

We note that the benchmarking prototype is a hypothetical system constructed using benchmarks and can adapt itself according to the production data of the system to be evaluated. Therefore, the translation function $G(\mathbf{x}) = \mathbf{x}$, i.e., $\mathbf{x}^{(b)} = \mathbf{x}$.

In the remainder of this section, if not otherwise noted, we denote:

- P —cement production system to be evaluated;
- $P^{(b)}$ —benchmark (usually best practice) cement production system;
- $E_i, E_i^{(b)}$ —energy consumption of the i th process-block for system P and $P^{(b)}$, respectively;
- $E_{i,j}, E_{i,j}^{(b)}$ —energy consumption of the j th process-step of the i th process-block for system P and $P^{(b)}$, respectively;
- $V_i, V_i^{(b)}$ —energy intensity of the i th process-block for system P and $P^{(b)}$, respectively;
- $V_{i,j}, V_{i,j}^{(b)}$ —energy intensity of the j th process-step of the i th process-block for system P and $P^{(b)}$, respectively;
- $V_{i,j,k}, V_{i,j,k}^{(b)}$ —energy intensity for making the k th type of product at the j th process-step of the i th process-block for system P and $P^{(b)}$, respectively.

The energy consumption of each subprocess can be calculated by the following formulas. For a clear view, we simplified the formulas by using aggregate energy intensity for each process-block or process-step. The actual calculation should handle different energy types (fuels and electricity) and give the results separately for final energy consumption and primary energy consumption.

(a) Process-block p_1 —preblending:

$$E_1 = E_{1,1} + E_{1,2} + E_{1,3} + E_{1,4} = x_2 \cdot V_{1,1} + x_3 \cdot V_{1,2} + x_3 \cdot V_{1,3} + x_8 \cdot V_{1,4},$$

$$E_1^{(b)} = E_{1,1}^{(b)} + E_{1,2}^{(b)} + E_{1,3}^{(b)} + E_{1,4}^{(b)} = x_2 \cdot V_{1,1}^{(b)} + x_3 \cdot V_{1,2}^{(b)} + x_3 \cdot V_{1,3}^{(b)} + x_8 \cdot V_{1,4}^{(b)}.$$

(b) Process-block p_2 —fuel preparation:

$$E_2 = E_{2,1} = x_9 \cdot V_{2,1},$$

$$E_2^{(b)} = E_{2,1}^{(b)} = x_9 \cdot V_{2,1}^{(b)}.$$

(c) Process-block p_3 —additives preparation:

$$E_3 = E_{3,1} = x_4 \cdot V_{3,1},$$

$$E_{3,2} = x_5 \cdot V_{3,2,1} + x_6 \cdot V_{3,2,2} + x_7 \cdot V_{3,2,3},$$

$$E_3^{(b)} = E_{3,1}^{(b)} = x_4 \cdot V_{3,1}^{(b)},$$

$$E_{3,2}^{(b)} = x_5 \cdot V_{3,2,1}^{(b)} + x_6 \cdot V_{3,2,2}^{(b)} + x_7 \cdot V_{3,2,3}^{(b)}.$$

In this analysis, the energy required by additive grinding and blending for blended cement production is included in the cement grinding (finish grinding).

(d) Process-block p_4 —kiln system—machinery use:

$$E_4 = E_{4,1} + E_{4,2} = x_{10} \cdot V_{4,1} + x_{10} \cdot V_{4,2} = x_{10} \cdot V_4,$$

$$E_4^{(b)} = E_{4,1}^{(b)} + E_{4,2}^{(b)} = x_{10} \cdot V_{4,1}^{(b)} + x_{10} \cdot V_{4,2}^{(b)} = x_{10} \cdot V_4^{(b)}.$$

(e) Process-block p_5 —kiln system—clinker making:

$$E_5 = E_{5,1} + E_{5,2} = x_{10} \cdot V_{5,1} + x_{10} \cdot V_{5,2} = x_{10} \cdot V_5,$$

$$E_5^{(b)} = E_{5,1}^{(b)} + E_{5,2}^{(b)} = x_{10} \cdot V_{5,1}^{(b)} + x_{10} \cdot V_{5,2}^{(b)} = x_{10} \cdot V_5^{(b)}.$$

(f) Process-block p_6 —cement grinding:

$$E_6 = E_{6,1} = \mathbf{x}_c \cdot \mathbf{V}_c,$$

$$E_6^{(b)} = E_{6,1}^{(b)} = \mathbf{x}_c^{(b)} \cdot \mathbf{V}_c^{(b)}.$$

Where: $\mathbf{x}_c = (x_{11}, x_{12}, \dots, x_{28})$ is a subvector of vector \mathbf{x} ; $\mathbf{V}_c = (V_{6,1,1}, V_{6,1,2}, \dots, V_{6,1,18})$ and

$\mathbf{V}_c^{(b)} = (V_{6,1,1}^{(b)}, V_{6,1,2}^{(b)}, \dots, V_{6,1,18}^{(b)})$ are two real vectors; centered dot “ \cdot ” denotes dot product (or scalar product) of vectors.

(g) Process-block p_7 —other production energy:

$$E_7 = E_{7,1} + E_{7,2} + E_{7,3} = x_1 \cdot V_{7,1} + x_{10} \cdot V_{7,2} + \left(\sum_{i=11}^{28} x_i \right) \cdot V_{7,3},$$

$$E_7^{(b)} = E_{7,1}^{(b)} + E_{7,2}^{(b)} + E_{7,3}^{(b)} = x_1 \cdot V_{7,1}^{(b)} + x_{10} \cdot V_{7,2}^{(b)} + \left(\sum_{i=11}^{28} x_i \right) \cdot V_{7,3}^{(b)}.$$

(h) Process-block p_8 —other non-production energy:

$$E_8 = E_{8,1} = \left(\sum_{i=11}^{28} x_i \right) \cdot V_{8,1},$$

$$E_8^{(b)} = E_{8,1}^{(b)} = \left(\sum_{i=1}^{28} x_i \right) \cdot V_{8,1}^{(b)} .$$

The total energy for system P is calculated by

$$E = \sum_{i=1}^8 E_i .$$

The total energy for system $P^{(b)}$ is calculated by

$$E^{(b)} = \sum_{i=1}^8 E_i^{(b)} .$$

The overall EII for the cement production system to be evaluated can be calculated by

$$EII = 100 * \frac{E}{E^{(b)}} .$$

The EII for process-block p_i ($i = 1, 2, \dots, 8$) can be calculated by

$$EII_i = 100 * \frac{E_i}{E_i^{(b)}} .$$

The total potential energy savings can be estimated by

$$e^{(d)} = E - E^{(b)} .$$

The potential energy savings for process-block p_i ($i = 1, 2, \dots, 8$) can be estimated by

$$e_i^{(d)} = E_i - E_i^{(b)} .$$

We note that: (1) the benchmarking at the process-step level is similar to the above calculations; (2) the above formulas demonstrate the basic calculations for benchmarking cement production, additional information (such as kiln type, fuel type, waste heat recovery, on-site generation and milling) is needed for the complete calculations required by benchmarking an actual cement facility.

The key benchmarks used for cement production are listed in Table 3.

Table 3. Key benchmarks for cement production.

Source: Estimated by the authors based on [31, 32, 44-50] and personal communications with other researchers and industry sources. Chinese data are mainly provided by the Energy Research Institute (ERI) of the National Development and Reform Commission (NDRC) and the China Cement Association.

Benchmarks	International best practices	Chinese best practices
$V_{1,1}^{(b)}$ —preblending (kWh/t raw material) ^a	0.7	0.7
$V_{1,2}^{(b)}$ —crushing (kWh/t raw material crushed)	0.38	0.7
$V_{1,3}^{(b)}$ —grinding (kWh/t raw material ground)	11.45 ^b	13.5
$V_{1,4}^{(b)}$ —homogenization (kWh/t raw material ground)	0.1	0.15
$V_{2,1}^{(b)}$ —fuel grinding and preparation (kWh/t coal)	18.6	22
$V_{3,1}^{(b)}$ —additive drying (GJ/t additive for drying)	0.25	0.61

$V_{3,2,1}^{(b)}$ —blast furnace and other slags grinding and blending (kWh/t) ^c	38	38
$V_{3,2,2}^{(b)}$ —fly ash grinding and blending (kWh/t)	20	20 ^d
$V_{3,2,3}^{(b)}$ —natural pozzolans grinding and blending (kWh/t)	20 ^e	20 ^e
$V_4^{(b)}$ —kiln mechanical electricity (kWh/t clinker)	22.5 ^f	26
$V_5^{(b)}$ —clinker making fuel (GJ/t clinker)	2.85	2.99
$V_{6,1,1}^{(b)}$ —42.5/42.5R pure Portland cement grinding (kWh/t cement)	25 ^g	28 ^g
$V_{6,1,2}^{(b)}$ —52.5/52.5R pure Portland cement grinding (kWh/t cement)	28 ^g	31 ^g
$V_{6,1,3}^{(b)}$ —62.5/62.5R pure Portland cement grinding (kWh/t cement)	29 ^g	32 ^g
$V_{6,1,4}^{(b)}$ —32.5/32.5R common Portland cement grinding (kWh/t cement)	23	26 ^g
$V_{6,1,5}^{(b)}$ —42.5/42.5R common Portland cement grinding (kWh/t cement)	25 ^g	28
$V_{6,1,6}^{(b)}$ —52.5/52.5R common Portland cement grinding (kWh/t cement)	28 ^g	31 ^g
$V_{6,1,7}^{(b)}$ —32.5/32.5R slag cement grinding (kWh/t cement) ^h	33 ^g	34 ^g
$V_{6,1,8}^{(b)}$ —42.5/42.5R slag cement grinding (kWh/t cement) ^h	34 ^g	35 ^g
$V_{6,1,9}^{(b)}$ —52.5/52.5R slag cement grinding (kWh/t cement) ^h	35 ^g	36 ^g
$V_{6,1,10}^{(b)}$ —32.5/32.5R fly ash cement ⁱ grinding (kWh/t cement)	29 ^g	29
$V_{6,1,11}^{(b)}$ —42.5/42.5R fly ash cement ⁱ grinding (kWh/t cement)	31 ^g	31 ^g
$V_{6,1,12}^{(b)}$ —52.5/52.5R fly ash cement ⁱ grinding (kWh/t cement)	34 ^g	34 ^g
$V_{6,1,13}^{(b)}$ —32.5/32.5R pozzolana cement ^j grinding (kWh/t cement)	30 ^g	30
$V_{6,1,14}^{(b)}$ —42.5/42.5R pozzolana cement ^j grinding (kWh/t cement)	32 ^g	32 ^g
$V_{6,1,15}^{(b)}$ —52.5/52.5R pozzolana cement ^j grinding (kWh/t cement)	35 ^g	35 ^g
$V_{6,1,16}^{(b)}$ —32.5/32.5R blended limestone cement ^k grinding (kWh/t cement)	24 ^g	27 ^g
$V_{6,1,17}^{(b)}$ —42.5/42.5R blended limestone cement ^k grinding (kWh/t cement)	26 ^g	29 ^g
$V_{6,1,18}^{(b)}$ —52.5/52.5R blended limestone cement ^k grinding (kWh/t cement)	29 ^g	32 ^g
$V_{7,1}^{(b)}$ —Quarrying (kWh/t ore)	- ^l	0.7
$V_{7,2}^{(b)}$ —Auxiliaries (kWh/t clinker)	4	4 ^d
$V_{7,3}^{(b)}$ —Conveyors (kWh/t cement)	1.5	1.5 ^d
$V_{8,1}^{(b)}$ —Lighting, office equipment, miscellaneous (kWh/t cement)	- ^m	- ^m

Note: all values in final energy. The abbreviation “t” denotes tonne. Because best practice energy intensities may depend strongly on the material inputs and the values presented here are estimated mainly based on literature and personal communications, the “best practice” values estimated in this paper should be considered as indicative. Care should be taken when making direct comparisons because of uncertainties in system boundaries and methodological issues.

^a Prehomogenization, proportioning and reclaiming.

^b Assume pre-heating of wet materials is negligible for this analysis, and do not include it here.

^c Separate grinding for blended cement production.

^d No Chinese data available, assume similar to international best practice.

^e Assume similar to fly ash.

^f Mechanical energy to power the fans, the kiln drive, the cooler and to transport materials to the top of the preheater tower requires, at a minimum, 22.5 kWh/t clinker (this does not include fuel grinding electricity).

^g Estimated by the authors.

^h Based on 65% slag (best practice). The values listed in the table are estimated according to Portland slag cement produced by separate grinding.

ⁱ Assume 30% fly ash.

^j Assume 35% pozzolans.

^k Assume 5% limestone is blended and the extra energy required is similar to fly ash grinding requirements.

^l If applicable to the cement facility, quarrying is estimated to use about 1% of the total electricity at the facility.

^m Lighting, office equipment, and other miscellaneous electricity uses are estimated to use about 1.2% of the total electricity at the facility.

7. Discussion and conclusions

Energy benchmarking is well recognized to be effective in helping to improve energy efficiency and to reduce carbon dioxide emissions. However, energy benchmarking is often challenging in real-world practice. A better understanding of the applicability, strengths, and limitations of industrial energy benchmarking is helpful for utilizing energy benchmarking more effectively and scientifically.

7.1. Discussion of process-based energy benchmarking

Process-based energy benchmarking is generally preferred for complex industrial production systems, which are usually composed of many highly interconnected processes and equipment, as it can provide insights into where the major inefficiencies are and which processes to focus on for improvement [7, 12, 16]. In other words, process-based benchmarking is very helpful for identifying the major potential for improving energy efficiency effectively.

In theory, process-based energy benchmarking can be applied to any industrial production system that can be decomposed to sub-processes. However, in real-world applications, it often requires great effort to design and implement processes-based energy benchmarking. The difficulty primarily lies in the three areas, discussed below.

First, the interconnections between sub-processes in an industrial production system are usually complex. Therefore, it is often difficult to decompose a complex system to sub-processes with clear boundaries. Furthermore, the relationships between sub-processes are often highly nonlinear and

varying, making it difficult to model this kind of complex system. In real-world benchmarking practices, decoupling, approximation, and linearization methods are often adopted to provide acceptable engineering analysis.

Second, it is very rare that two real industrial systems have exactly the same production processes and homogeneous energy-governing factors [28]. Reasonable assumptions and mathematical transformations and normalizations are often necessary to make benchmarking comparable.

Third, it is often difficult to acquire relevant and sufficient energy data for the processes. On one hand, energy performance measurement and verification is sometimes difficult, especially for those industrial facilities which lack energy measurement and management but need to improve their efficiencies. On the other hand, detailed energy information is often sensitive due to concerns about competitiveness, proprietary data or politically sensitive areas such as climate negotiations. Companies or industries are often reluctant to release detailed information on their energy use [16]. Therefore, data collection and availability is often a challenge for industrial energy benchmarking efforts. Large uncertainties in data are also a major concern [2]. To a large extent, high quality and sufficient data are the key to success of benchmarking analysis and practices [2].

The following are needed for wider application of process-based benchmarking in industries: (1) Greater involvement of more technicians and engineers in various industrial areas as they usually have in-depth understanding of the industrial production process and are the major potential users of benchmarking. The practical experiences and feedback from the technicians and engineers are very important for the application of process-based energy benchmarking. (2) More resources and tools should be available for in-house use in companies. Companies may want to evaluate their energy performance to estimate the potential energy savings without disclosing their detailed energy data. A comprehensive and user-friendly tool is helpful for such users to benchmark their energy performance by themselves or with only little outside help. (3) Demonstrations of the usefulness of benchmarking should be made for stakeholders (especially the leaders or managers of the industries) so that they can recognize the importance and advantages of benchmarking. In countries like China, support from government and governmental associations of industries are often critical for energy benchmarking programs and initiatives.

7.2. Discussion of product-based energy benchmarking

Compared to process-based approaches, product-based energy benchmarking is simple in terms of methodology and requires much less data. On one hand, product-based approaches greatly simplify the benchmarking process and reduce the burden to collect detailed production process-related data, which is very helpful in reducing the concerns of stakeholders regarding proprietary information. The applicability of the product-based energy benchmarking is thus much wider than process-based approaches. On the other hand, product-based approaches only give aggregate benchmarking results, which usually do not help determine why the inefficiency exists and where the major inefficiencies are

as the detailed information on the production processes is missing. It is difficult to effectively improve efficiency without a good understanding of the fundamentals behind a production process.

Aggregate energy intensity of the product is usually used as the major efficiency indicator for product-based energy benchmarking. For simplicity, energy intensity of the product is usually assumed to be a metric irrespective of plant size, scale of production line or production volume [16]. It should be noted that in real-world industrial production, energy intensity is often related to plant size, and scale of production lines as well as material input, production volume, and product type and grade. For example, producing a large quantity of one product on an advanced mass production line is very likely to be more energy-efficient in terms of energy consumption per unit of product than producing the same amount of the same product on a relatively outdated small scale production line. On the other hand, producing a small quantity of one product on an advanced mass production line (e.g., the production volume only accounts for five percent of the productive capacity of the production line) does not necessarily consume less energy than producing the same amount of the same product on a relatively outdated small scale production line which is operating at near-optimal capacity utilization rate. Therefore, care should be taken when using aggregate energy intensity indicator to make direct comparisons.

The EII of an industrial plant or sector is a very straightforward metric for energy intensity comparisons and is widely used in energy benchmarking practices [2, 17]. We note that the EII is a percentage that describes the relative energy performance, and this index can thus be used to compare the overall performance of different plants or sectors without revealing proprietary information, which is generally preferred by industrial plants or sectors in competitive markets [2, 13, 16, 17]. However, the information given by an EII value of an industrial plant or sector is very limited, especially if the relevant data of the benchmarks are not available. Furthermore, it is also difficult to interpret an overall EII value without information on production process and energy utilization. If different products (types or grades) and energy types (such as fuels and electricity) are involved in the industrial plant or sector, which is often the case, an aggregate EII number is not very informative for benchmarking.

We note that the attitude of stakeholders towards benchmarking is often critical due to the proprietary nature and data privacy of the industrial plants or sectors. Even so, the wide application of energy benchmarking in industry, especially for those energy-intensive heavy industries, could be very beneficial. Either relatively simple product-based benchmarking or relatively complex process-based benchmarking is helpful in identifying inefficiencies and estimating potential energy savings and carbon emissions reduction. Process-based benchmarking also helps determine major inefficiencies and improve energy efficiency more effectively.

Given the analyses and discussions conducted in this study, we conclude with the following remarks:

(1) The basic idea of energy benchmarking is to evaluate the energy performance of an individual system against a reference system. Energy benchmarking can be designed to compare the energy performance of an individual system against a reference system that represents best practice, or to compare the energy performance of a number of systems against one another or to compare the plant against itself

in different periods or operation conditions. Energy benchmarking based on best practice is particularly useful for identifying the energy inefficiencies in production processes to estimate the potential for energy savings.

(2) Product-based energy benchmarking at the plant or sector level helps to determine the gap between the plants or sectors and to estimate the overall potential for energy efficiency improvement. Process-based benchmarking provides insights into where the major energy saving potential actually is and which areas or processes should be focused on and improved. Product-based energy benchmarking can be viewed as a particular case of the process-based energy benchmarking.

(3) The formal general system description of energy benchmarking from the perspective of systems engineering and the resulting systems engineering methodologies presented in this paper provide a general unified framework for analyzing and implementing industrial energy benchmarking.

(4) The analysis of an energy benchmarking prototype demonstrates the process-based benchmarking approaches within the general framework presented in this paper are helpful in identifying the major inefficiencies and estimating the potential for energy savings.

Acknowledgments

This work was supported by the Energy Foundation and Dow Chemical Company (through a charitable contribution) through the Department of Energy under contract No.DE-AC02-05CH11231. The authors thank the three anonymous reviewers for their valuable and constructive comments and suggestions.

References

- [1] Fleiter T, Fehrenbach D, Worrell E, Eichhammer W. Energy efficiency in the German pulp and paper industry – A model-based assessment of saving potentials. *Energy*. 2012;40(1):84-99.
- [2] Saygin D, Worrell E, Patel MK, Gielen DJ. Benchmarking the energy use of energy-intensive industries in industrialized and in developing countries. *Energy*. 2011;36(11):6661-73.
- [3] Saygin D, Worrell E, Tam C, Trudeau N, Gielen DJ, Weiss M, et al. Long-term energy efficiency analysis requires solid energy statistics: The case of the German basic chemical industry. *Energy*. 2012;44(1):1094-106.
- [4] Ozawa L, Sheinbaum C, Martin N, Worrell E, Price L. Energy use and CO₂ emissions in Mexico's iron and steel industry. *Energy*. 2002;27(3):225-39.
- [5] Price L, Sinton J, Worrell E, Phylipsen D, Hu X, Li J. Energy use and carbon dioxide emissions from steel production in China. *Energy*. 2002;27(5):429-46.
- [6] Ke J, Zheng N, Fridley D, Price L, Zhou N. Potential energy savings and CO₂ emissions reduction of China's cement industry. *Energ Policy*. 2012;45:739-51.
- [7] Worrell E, Price L. An integrated benchmarking and energy savings tool for the iron and steel industry. *Int J Green Energy*. 2006;3(2):117-26.
- [8] Worrell E, van Heijningen RJJ, de Castro JFM, Hazewinkel JHO, de Beer JG, Faaij APC, et al. New gross energy-requirement figures for materials production. *Energy*. 1994;19(6):627-40.
- [9] Schipper L, Unander F, Murtishaw S, Ting M. Indicators of energy use and carbon emissions: Explaining the energy economy link. *Annu Rev Energ Environ*. 2001;26:49-81.
- [10] International Energy Agency (IEA). *Tracking Industrial Energy Efficiency and CO₂ Emissions*. Paris: International Energy Agency, 2007.
- [11] Martin N, Worrell E, Schipper L, Blok K. International Comparisons of Energy Efficiency. *Proc. International Comparisons of Energy Efficiency Workshop, Berkeley, California, USA*. 1994, p. 1-66.
- [12] Camp RC. *Benchmarking: The Search for Industry Best Practices that Lead to Superior Performance*. Milwaukee, Wisconsin: ASQC Quality Press, 1989.
- [13] Phylipsen GJM, Nyboer J, Oliver JT, Pape A, Worrell E, Blok K. Methodologies for International Comparisons of Industrial Energy Efficiency. *Proc. Workshop on Methodologies for International Comparisons of Industrial Energy Efficiency, Vancouver, BC, Canada*. 1996, p. 1-33.
- [14] Phylipsen D, Blok K, Worrell E, de Beer J. Benchmarking the energy efficiency of Dutch industry: an assessment of the expected effect on energy consumption and CO₂ emissions. *Energ Policy*. 2002;30(8):663-79.
- [15] Phylipsen GJM, Blok K, Worrell E. International comparisons of energy efficiency-Methodologies for the manufacturing industry. *Energ Policy*. 1997;25(7-9):715-25.
- [16] Ruth M, Worrell E, Price L. A process-step benchmarking approach to energy use at industrial facilities: examples from the iron and steel and cement industries. *Proc. 2001 ACEEE Summer Study on Energy Efficiency in Industry, Tarrytown, NY, USA*. 2001, p. 149-60.
- [17] Birchfield GS. Issues and challenges in energy benchmarking. *Energ Eng*. 2001;98(2):38-52.
- [18] ENERGY STAR. ENERGY STAR for Industry. 2011. <
http://www.energystar.gov/index.cfm?c=industry.bus_industry >

- [19] ENERGY STAR. ENERGY STAR Industrial Benchmarking Tools. 2011. <
<http://www.energystar.gov/index.cfm?c=industry.industrybenchmarkingtools> >
- [20] ENERGY STAR. ENERGY STAR Certification for Plants. 2011. <
http://www.energystar.gov/index.cfm?c=industry.bus_industry_plants >
- [21] Price L, Wang XJ, Jiang Y. The challenge of reducing energy consumption of the Top-1000 largest industrial enterprises in China. *Energ Policy*. 2010;38(11):6485-98.
- [22] National Development and Reform Commission (NDRC). Implementation Suggestions of the Ten Key Energy Conservation Projects during the Eleventh Five Year Plan Period. Beijing, China: National Development and Reform Commission; 2006.
- [23] National Development and Reform Commission (NDRC). The Thousand Enterprises Exceeded the Energy-Saving Target during the 11th Five Year Plan. 2011. <
http://zys.ndrc.gov.cn/xwfb/t20110314_399361.htm >
- [24] Center for Industrial Energy Efficiency (CIEE). China Industrial Energy Efficiency Report 2011 – Achievements and Lessons Learned in the 11th Five-Year Plan Period. Beijing, China: China Ocean Press, 2012.
- [25] Ke J, Price L, Ohshita S, Fridley D, Khanna NZ, Zhou N, et al. China's industrial energy consumption trends and impacts of the Top-1000 Enterprises Energy-Saving Program and the Ten Key Energy-Saving Projects. *Energ Policy*. 2012;50:562-9.
- [26] Energy Research Institute of China (ERI). Guidebook for the Financing of Energy Efficiency and Renewable Energy Projects. Beijing: China Environmental Science Press, 2010.
- [27] National Bureau of Statistics (NBS). China Statistical Yearbook 2011. Beijing: China Statistics Press, 2011.
- [28] Efficiency Valuation Organization (EVO). International Performance Measurement and Verification Protocol, Volume 1: Concepts and Options for Determining Energy and Water Savings. EVO 10000–1:2010. Washington, DC: Efficiency Valuation Organization; 2010.
- [29] Wang Y. Systems Engineering Theory, Methodology, and Applications, 2nd Edition. Beijing: Higher Education Press, 1998.
- [30] Wang Y. Systems Engineering, 4th Edition. Beijing: China Machine Press, 2011.
- [31] Worrell E, Price L, Neelis M, Galitsky C, Zhou N. World Best Practice Energy Intensity Values for Selected Industrial Sectors (Rev.2). Berkeley, CA: Lawrence Berkeley National Laboratory; 2008. <
<http://china.lbl.gov/publications/world-best-practice-energy-intensity-values-selected-industrial-sectors> >
- [32] Galitsky C, Price L, Zhou N, Zhou F, Xiong H, Zeng X, et al. Guidebook for Using the Tool BEST Cement. Berkeley, CA: Lawrence Berkeley National Laboratory.2008. <
<http://china.lbl.gov/publications/guidebook-using-tool-best-cement> >
- [33] European Cement Association (CEMBUREAU). Key facts & figures. 2012. <
<http://www.cembureau.eu/about-cement/key-facts-figures> >
- [34] China Cement Association (CCA). China Cement Almanac 2010. Nanjing: Jiangsu People's Publishing House, 2011.
- [35] Worrell E, Price L, Martin N, Hendriks C, Meida LO. Carbon dioxide emissions from the global cement industry. *Annu Rev Energ Environ*. 2001;26:303-29.
- [36] Zeng X. Cement industry fully launches energy efficiency benchmark. *China Cement*. 2010;(4):25-7.

- [37] European Environment Agency (EEA). Benchmarking in the cement industry. 2012. < <http://www.eea.europa.eu/data-and-maps/figures/benchmarking-in-the-cement-industry-1> >
- [38] Matthes FC, Repenning J, Worrell E, Phylipsen D, Müller N. Pilot on Benchmarking in the EU ETS. Berlin/Utrecht: Oeko-Institut/Ecofys.2008. < http://www.dehst.de/SharedDocs/Downloads/Archiv/Benchmark/BM_Pilot_OekoInst_Ecofys_EN.pdf?__blob=publicationFile >
- [39] Canadian Industry Program for Energy Conservation (CIPEC). Canadian Cement Industry Energy Benchmarking Summary Report. Ottawa, ON: Canadian Industry Program for Energy Conservation. 2009. < <http://www.cement.ca/images/stories/NRCan%20Report%20English%20Final.pdf> >
- [40] Canadian Industry Program for Energy Conservation (CIPEC). Benchmarking Guides. 2011. < <http://oee.nrcan.gc.ca/industrial/technical-info/benchmarking/general/10678> >
- [41] Cement Sustainability Initiative (CSI). Sectoral CDM Benchmarking Methodology. 2012. < <http://www.wbcscement.org/index.php/key-issues/climate-protection/cdm-benchmarking> >
- [42] Hermann H. Benchmarking in the EU. 2010. < http://www.ecy.wa.gov/climatechange/docs/GHGbenchmark_20100519_Hermann.pdf >
- [43] Centre for European Policy Studies (CEPS). Benchmarking in the EU ETS and Beyond. 2012. < <http://www.ceps.eu/taskforce/benchmarking-eu-ets-and-beyond> >
- [44] Wang Z. Grinding Technology for Cement Industry. Beijing: China Building Materials Press, 2000.
- [45] Wang Z, Zeng R. Cement Grinding Technology and Progress. Beijing: China Building Materials Press, 2008.
- [46] European Cement Association (CEMBUREAU). "Best Available Techniques" for the Cement Industry. Brussels, Belgium: CEMBUREAU; 1999.
- [47] European Commission, Joint Research Centre. Best Available Techniques (BAT) Reference Document for the Production of Cement, Lime and Magnesium Oxide. Seville, Spain: European Commission, Joint Research Centre; 2012.
- [48] Zeng X, Yu W, Hu Z, Tao C, Liu J, Chai X, et al. A guide to energy benchmarking for cement plants. *Cement*. 2009;(6):1-9.
- [49] Zhang Y, Wang Q, Wang Q. Advances in roller press combined grinding system. Proc. 2009 China Annual Conference on Cement Technology and the 11th China Technical Exchange Conference on Cement Technology, Chongqing, China. 2009, p. 50-7.
- [50] Deng X, Ye W, Wang G, Zhang W, Li J, Zhang X. Application of HRM4800 roller mill in 5000 tpd clinker production line. *China Cement*. 2009;(3):51-6.