

Lawrence Berkeley National Laboratory

Lawrence Berkeley National Laboratory

Title

Developing a next-generation community college curriculum for energy-efficient high-performance building operations

Permalink

<https://escholarship.org/uc/item/5x2110kc>

Authors

Crabtree, Peter
Kyriakopedi, Nick
Mills, Evan
[et al.](#)

Publication Date

2004-05-01

Developing a Next-Generation Community College Curriculum for Energy-Efficient High-Performance Building Operations¹

Peter Crabtree, Peralta Community College District
Nick Kyriakopedi, Laney College
Evan Mills, Philip Haves, Roland J. Otto, Mary Ann Piette, Peng Xu, Rick Diamond,
Lawrence Berkeley National Laboratory
Joe Deringer, The Deringer Group
Chuck Frost, Lawrence Livermore National Laboratory

ABSTRACT

The challenges of increased technological demands in today's workplace require virtually all workers to develop higher-order cognitive skills including problem solving and systems thinking in order to be productive. Such "habits of mind" are viewed as particularly critical for success in the information-based workplace, which values reduced hierarchy, greater worker independence, teamwork, communications skills, non-routine problem solving, and understanding of complex systems. The need is particularly compelling in the buildings arena. To scope the problem, this paper presents the results of interviews and focus groups—conducted by Oakland California's Peralta Community College District and Lawrence Berkeley National Laboratory—in which approximately 50 industry stakeholders discussed contemporary needs for building operator education at the community college level. Numerous gaps were identified between the education today received by building operators and technicians and current workplace needs. The participants concurred that many of the problems seen today in achieving and maintaining energy savings in buildings can be traced to inadequacies in building operation and lack of awareness and knowledge about how existing systems are to be used, monitored, and maintained. Participants and others we interviewed affirmed that while these issues are addressed in various graduate-level and continuing education programs, they are virtually absent at the community college level. Based on that assessment of industry needs, we present a new curriculum and innovative simulation-based learning tool to provide technicians with skills necessary to commission and operate high-performance buildings, with particular emphasis on energy efficiency and indoor environmental quality in the context of HVAC&R equipment and control systems.

Motivating Rationale, Broader Impacts, Goals, and Objectives

The initiative described in this paper addresses an acute need for higher levels of practical and conceptual engineering technology skills among graduates of community college programs in heating, ventilation, air conditioning, and refrigeration (HVAC&R) and related specializations. Our primary focus is on the increasingly complex field of building operations and management in which occupant comfort, indoor air quality, and energy

¹ The work described in this paper was sponsored by the Peralta Community College District, the U.S. Department of Energy Office of Science, and the Assistant Secretary for Energy Efficiency and Renewable Energy, Office of Building Technology, of the U.S. Department of Energy under Contract No. DE-AC03-76SF00098. Author for Correspondence: Evan Mills, LBNL, 510-486-6784, emills@lbl.gov. Available online at http://eetd.lbl.gov/emills/PUBS/Comm_College_Edn.html

management must be balanced. Lack of training is widely seen as one of the single most important barriers to improving the quality and performance of buildings. As the technological evolution of this field has accelerated over the past decade, programs in two-year colleges across the country have not always kept pace. The need for increased attention to vocational level college curriculum in this area is evidenced by our review of current offerings and from the minimal emphasis given to the topic by major sponsors of innovation in education.² This paper describes a new initiative to modernize curriculum and learning experiences in this arena. Particular emphasis is given to an innovative computer-based education strategy, employing real-time simulations of building mechanical systems.

The dramatic evolution of skill requirements for technicians has been apparent to observers for more than a decade. As described by Carnevale (1991), “[w]ith the assistance of flexible information technologies, technicians are assuming functions previously performed by scientists and engineers”. As a consequence, the education of technicians must provide solid academic *and* practical foundations, preparing them not only to be technically knowledgeable and capable but also to be quite comfortable with problem solving, creative thinking, working autonomously, and working effectively with others. The necessary transformation of technician education is widely recognized throughout the industrialized world, as are the challenges posed by the need to raise the status of technicians overall and to attract more capable students into technician-level fields (Mahoney and Barnett 1998). The link between the initiative described here and the practice of science in this arena derives from the recognition that within the building performance research community one of the greatest challenges is to design and effectively operate and maintain building energy management and control systems. This coincides with the fact that public and private energy management R&D portfolios are moving away from a “stovepipe” approach to an “integrated systems” approach. Those who successfully acquire new skills will be able to participate in associated emerging professional specialties such as commissioning and retrofitting buildings, managing building energy use and maintaining optimal performance, and analyzing and correcting all-too-common system faults. In fact, entirely new technical fields—e.g. “building commissioning”—have emerged and require additions to the labor force at all skill levels, yet today little or no community college-level training is available.

Industry Needs, Employment Opportunities, and Skills Required

Others have convened stakeholders to assess broad education needs in the energy sector (e.g. PETE and ATEEC 2000). To more precisely identify industry needs in our particular area of interest, on September 5, 2003 Peralta Community College District and Lawrence Berkeley National Laboratory held a half-day focus group meeting. The overarching aim was to advance understanding of industry needs and to obtain an informed critique of our initial curriculum plan.

² For example, based on a title and content search of over 500 abstracts of projects funded by the National Science Foundation, it appears that the subject of energy-efficient buildings has never before been the central focus. (Lane Community College, in Oregon, is said to have received related NSF funding in 1980).

Figure 1. A diversity of stakeholders have helped define the

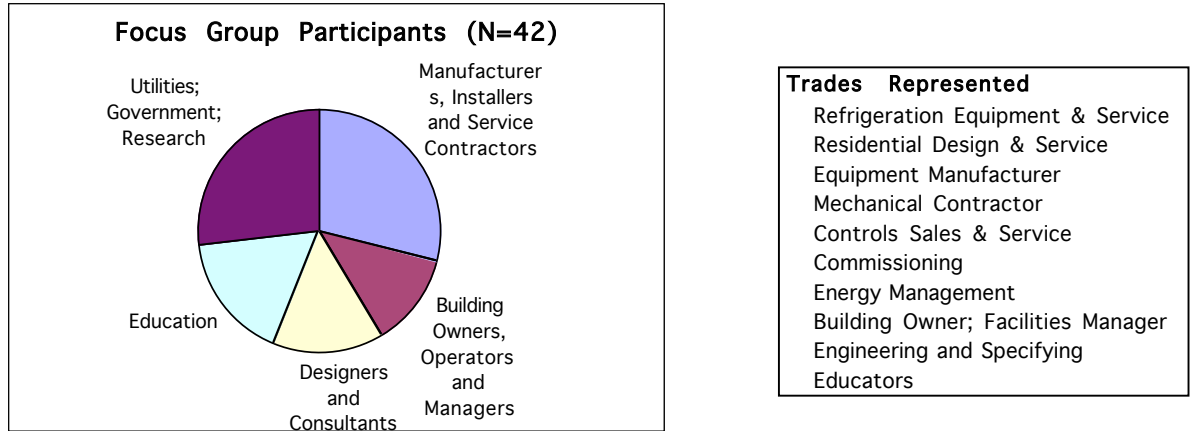

The 42 participants represented a broad spectrum of industry stakeholders (Figure 1), including contractors and consultants, facility owners and managers, equipment manufacturers, energy policymakers, energy providers, researchers, and educators (high school and community college). These groups also represent future employers of graduates of the community colleges that would utilize the curriculum we are developing.

The focus group considered three issue areas: (1) Industry Needs, Opportunities, and Skills Required; (2) Curriculum Analysis and Development; and (3) Learning Methods. Breakouts were held among five working groups representing various segments of the industry. The participants provided written and verbal reports, widely agreeing that many of the problems seen today in achieving and maintaining energy savings can be traced to inadequacies in the operation of facilities, and lack of awareness and knowledge about how existing systems are intended to be used. Successful operation of buildings requires understanding and preserving the “design intent” behind the systems, an ability to respond to changing conditions, appreciating the link between energy-using systems and human comfort and occupant satisfaction, productivity, etc. Participants and others we have interviewed confirmed that while these issues are addressed in various graduate-level programs, they are virtually absent at the community college level.

In addition to the aforementioned transition from a “components” to a “systems” perspective, a number of key market trends and drivers were identified, underpinning the need for evolutionary changes in Peralta Community College’s existing core curriculum (offered via one of its four campuses, Laney College). These include:

- emergence of new technologies and practices (which corresponds with an associated shift from mechanical to electronic equipment).
- growing awareness of the economic and non-economic costs of equipment performance problems, especially as relates to worker productivity.
- new “green building” mandates by local and state governments
- industry initiatives such as LEED (Leadership in Energy and Environmental Design).
- the role that sophisticated building operators can play in addressing macro-level energy system challenges such as peak demand management and reliability, rising concerns about indoor air quality and mold, and risk management.
- the trend towards increasing energy prices and more complex energy rate structures (e.g. time-of-use tariffs), which calls for a new awareness among building operators in order to understand and take advantage of cost-savings opportunities.

- the rapidly increasing importance of energy performance measurement and verification.
- an emerging recognition of the specialized performance problems and opportunities in high-tech facilities (laboratories, cleanrooms, data centers), ultra cold environments, and other specialized applications.

Numerous more specific gaps were identified between the education today received by building operators and current-day needs. Areas that were frequently (and sometimes universally) noted include:

Technical Skills: Basic building science: physics and math and theory of how buildings work; Diagnosing and trouble-shooting problems; Control system programming (e.g. sequences of operations); Sustainable design; green buildings; Performance measurement and analysis (e.g. collection *and* assessment of energy data); Information technology and networking; Safety and risk management.

Business Skills: Working with people, reporting, etc.; Economic and financial analysis (including assessment of non-economic benefits), Communicating analyses and recommendations to decision makers; Critical thinking; and problem solving.

Improved Laney College Curriculum & Learning Environment

In its current form, the 30-year-old the Environmental Control Technology (ECT) program offered by Peralta’s Laney College is similar in content to HVAC&R programs at community colleges around the country. Typical certificate tracks range in length from two to three semesters, with associates degree programs adding a fourth semester. Completing the program requires two full semesters plus one lighter semester.

The Focus Group helped refine a plan for major updates and revisions to Laney’s curriculum. The plan will “build in” through the adoption of new instructional technologies and methods; it will “build out” through the creation of new program strands associated with emerging occupational clusters, through the addition of physics, statistical methods, and communications courses, and through the addition of a rigorous associates degree option; it will “build up” through the addition of advanced courses associated with the new strands to serve both current students and incumbent workers needing skills upgrades; and it will “build through” by providing an articulated sequence of courses so that students may transition to 4-year institutions.

Table 1 summarizes the resulting revised curriculum matrix. The rows represent courses and the columns show occupational “strands” that will correspond to specific certificate and degree options. The matrix indicates which courses exist in the current curriculum, and which will be created or adapted through the proposed project. The result is a fundamental evolution of the curriculum: eighteen new courses have been identified, and all of the strands are new.

The projected complement of core and advanced courses differs significantly from that typically found at the community college level. Existing programs focus primarily on component-level technologies, but provide a superficial treatment of the broader energy and building performance issues. Nor are the key emerging issues such as the roles of performance monitoring, fault detection, and diagnostics widely addressed. Of note, the Building Operator Certification (BOC) program, operated by the Northwest Energy Efficiency Council and licensed to a number of organizations throughout the US, provides

community college credit in some cases, although primarily focused on continuing education and providing fewer hours of training per subject than the curriculum proposed here.

Table 1. Proposed curriculum

<----- Proposed Certificate and Degree Program Strands to Be Developed----->

Course	Course Status	Semester	Units	Proposed Certificate and Degree Program Strands to Be Developed						Comments
				REFRIGERATION TECHNICIANS	HVACR TECHNICIANS	BUILDING OPERATORS	CONTROLS TECHS	COMMISSIONING TECHS		
Core Courses										
Basic Environmental Control Technology	E	4	3 / 3	X	X	X	X	X		
Residential & Light Commercial HVAC&R Troubleshooting	E	4	3 / 3	X	X	X	R	X		
Mechanical & Electrical Devices	E	4	3 / 3	X	X	X	X	X		
Principles & Practices of Env. Control Tech.	E	4	3 / 3	X	X	X	X	X		
Special Processes & Devices	E	4	3 / 3	N/R	X	X	X	X		
HVAC Principles & Practices	E	4	3 / 3	N/R	X	X	X	X		
Physics for Building Science	E	4	3 / 3	X	X	X	X	X		To be adapted from existing course.
Fundamentals of Energy Mgt & Efficiency	N	1	1 / 0	R	X	X	X	X		Added to existing program core.
Electricity & Instrumentation	N	4	3 / 3	X	X	X	X	X		
Brazing & Soldering	E	1	.5 / 1.5	X	X	X	N/R	N/R		To be upgraded from existing.
Blue Print Reading & Interpretation	E	2	2 / 0	R	X	X	X	X		To be upgraded from existing.
Motors & Drives	N	2	1.5 / 1.5	X	X	X	X	X		Added to existing program core.
DDC Controls - I	N	2	1.5 / 1.5	N/R	X	X	X	X		Added to existing program core.
Building Commissioning - I	N	2	1 / 3	N/R	X	X	X	X		Added to existing program core.
Intro to Computer Information Systems	E	2	1 / 3	X	X	X	X	X		Added to core. To be customized to include introduction to networks.
Expanded Curriculum										
Intermediate Algebra	E	4	4 / 0	R	X	X	X	X		To be adapted from existing course.
Professional Communications	E	3	3 / 0	R	X	X	X	X		
Psychrometrics & Load Calculations	N	2	2 / 0	X	X	X	N/R	R		
HVAC System Design	N	2	2 / 0	N/R	R	R	X	X		
Mechanical & Electrical Codes	N	2	2 / 0	X	X	X	N/R	X		
Testing, Adjusting, & Balancing	N	2	1 / 3	N/R	X	X	N/R	X		
Intro To Bldg Energy Management Systems	N	1	1 / 0	N/R	X	X	X	X		
Energy Efficient Lighting Design & Application	N	2	2 / 0	N/R	N/R	X	X	X		
Statistical Methods for Data Analysis	E	4	3 / 3	R	X	X	X	X		To be customized from existing.
DDC Controls - II	N	2	1 / 3	N/R	X	R	X	X		
Building Commissioning - II	N	2	1 / 3	N/R	R	R	N/R	X		
Building Envelope & Indoor Air Quality	N	1	1 / 0	N/R	R	X	N/R	X		
Distributed Power Generation	N	1	1 / 0	N/R	R	X	X	R		
Eutectic Refrigeration	N	1	.5 / 1.5	R	N/R	N/R	N/R	N/R		
Ultra-low Refrigeration Systems	N	1	.5 / 1.5	R	N/R	N/R	N/R	N/R		
High-Tech Facilities	N	1	.5 / 1.5	R	X	X	R	R		

KEY

Required Course	X
Recommended Course	R
Course Not Required	N/R
Existing Course	E
To be Upgraded or Revised from Existing	E
New Course	N

1 Lecture unit is 17.5 clock hours
1 Lab unit is 52.5 clock hours

advanced digital control systems, data collection, analysis, and correlation with operating equipment and systems; fundamental emphasis on system-level analysis and troubleshooting; specialized courses on high-tech facilities, ultra-cold facilities, and eutectics; integration of indoor air quality analysis; analysis of peak-load responsiveness (as distinct from energy efficiency); and issues facing building operators when needing to respond to a threat of biological or chemical attacks. In addition, we have found no other program that utilizes computer simulation in the way we propose (described below).

Instructional Strategies

The challenges arising from the increased technological demands of today's workplace require virtually all workers to develop higher-order cognitive skills including creative thinking, problem solving, and systems thinking in order to be productive. For technicians such "habits of mind" are viewed as particularly critical for success in the "information-based workplace" which values reduced hierarchy, greater worker independence, teamwork, communications skills, non-routine problem solving, and understanding of complex systems (Grubb 2000). For building science technicians, the need for system thinking skills is even more compelling.

This shift in our thinking about what constitutes key dimensions of workplace basics has been the source of much deliberation by educators on how to teach the new skills, marked by a decided tilt toward constructivist teaching strategies, and a new emphasis on teaching for understanding (Wiggins and McTighe 1998). In this new model of less teaching and more learning, students must figure things out, be immersed in complex problems often with multiple solutions, and operate in a problem-solving context.

The work of Bransford (1999) on learning and cognition provides reference to the concept of "Anchored Instruction" through the use of multimedia materials that simulate realistic "macro-contexts" for learning and the construction of knowledge. Bransford's work is informed by Lave's conception of "Situated Learning" which emphasizes the importance of the social context of learning—learning that takes place within a "community of practice" and that develops problem-solving skills through the representation of authentic and realistic settings. Bransford's work on representational instructional strategies is also supported by the "Cognitive Flexibility" theory of Spiro and others according to which interactive instruction should avoid oversimplification of problem settings, build interactive context, and be case-based to support knowledge construction.

With these perspectives in mind, we have examined alternative teaching strategies and methods to extend the knowledge and understanding of students preparing for technical careers in the building sciences. To this, we have added another instructional tool, a computer-based simulator that will also immerse students in progressively more complex problem-solving scenarios—from components to systems.

In addition, we have begun to develop a strategy using field analysis of data and operating equipment to further immerse students in real-world problems and issues. The lead instructor at Peralta's Laney College and two of his students worked directly on a program to retro-commission buildings in Oakland (with The Oakland Energy Partnership) in the summer of 2003. Guided by LBNL scientists, they carried out building audits of indoor air quality issues, comfort concerns, and energy savings opportunities from operational improvements. We plan to continue the involvement of students and faculty in the program as it expands into other parts of California.

Focus Group participants validated and helped refine our proposed strategy of adopting a diversity of approaches to teaching, with a blend of laboratory, simulation, and real-world problem solving. These include in-field work such as internships with actual practitioners, teaching proficiency in computer tools (e.g., controls programming and energy analysis software), and the use of "flight simulator" types of tools to give students the ability

to diagnose and troubleshoot progressively more complex problems.³ There was a general consensus regarding a combined approach involving real buildings, laboratory experiences and computer simulations. Team learning was suggested as a way to reinforce systems-level thinking. Many participants suggested that practitioners be brought into the classroom, and quite a few volunteered to collaborate with us in this fashion and in providing internships.

Computer-Based Education (CBE) Tool for Building Environmental Control

Simulation tools can be very effective, transportable computer-based education method of instruction. If properly employed, retention is typically higher than for traditional teaching modes, and content can be mastered much faster. We are developing an HVAC CBE tool to support a broad range of curriculum objectives across all of the tracks show in Table 1. It encourages students to:

- Understand the operating principles of HVAC system components
- Diagnose basic equipment problems at the component level
- Use goal-oriented, problem-solving methods at a systems level to find solutions to more complex equipment problems
- Focus on problem-solving methodologies in finding system-level solutions
- Focus on case-study exercises and ‘project-based learning’

The proposed HVAC CBE tool has several key attributes, as follows:

- ***Goal-oriented, problem-solving methodology*** The tool demonstrates and explains problem-solving methodologies in order to encourage students to use a consistent problem-solving process. Typical steps include: (1) identify potential problems, (2) select problems to analyze, (3) examine root causes, (4) identify possible solutions, (5) select, test, and implement solutions, and (6) monitor the effectiveness of the solutions. The CBE tool is structured to so that this methodology can be applied to a series of case-study projects of varying complexity across a range of HVAC components and systems, climates and costs, and problem-solving situations such as commissioning of a building’s HVAC system at the end of construction, diagnosing HVAC problems that occur during building operations, diagnosing indoor air quality problems from many sources including mold and mildew, or improving the energy-efficiency of the HVAC system during building design or retrofit.
- ***Highly-interactive, animation-oriented Graphic User Interface (GUI)***: The GUI will provide clear animations and other graphics to explain concepts, and will allow (1) the user’s focus to alternate between component and system levels, (2) both structured exercises and open-ended exploration, and (3) open-ended solutions, where there is no single correct answer, but rather a range of possible acceptable solutions. The GUI will also provide feedback to students HVAC system status and components being examined, track student progress toward exercise objectives, provide or hide “Hints” and other assistance to support learning objectives, and allow recording of student progress and test scores. The GUI will be easy-to-use and will be able to provide a consistent interactive environment for both Web and CD use, and across a range of problem situations and graphical “look-and-feels” (which might vary by situation). The GUI will also be able to totally hide the

³ The Executive Director of the Partnership for Environmental Technology Education (PETE) has noted that stakeholder groups they have convened to discuss energy education at the community college level have repeatedly expressed interest in simulator-based learning experiences in which students are exposed to model-based training, followed by hands-on training in the field.

interface complexity of the simulation programs used.

- **Simulation Engine(s):** SPARK will be the basic simulation engine for the CBE tool, although other engines may also be used. SPARK is an object-based simulation program that uses graph-theoretic methods to find computationally efficient solutions to problems described by sets of non-linear differential and algebraic equations (Sowell and Haves 2001).
- **“Open-Source” Software Approach:** Using an “open-source” software approach will facilitate the refinement and expansion of the CBE tool, both by instructors and by other interested parties. To support this approach, we will utilize widely available software platforms and languages.
- **Major elements of the CBE tool already exist.** Members of our team have already produced working products containing many elements of the proposed CBE tool. For example, the underlying structure and features of the (1) goal-oriented, problem-solving paradigm, (2) GUI, and (3) database-driven structures and SQL calls for both technical and administrative applications within the CBE tools are now working in both CD and web-based environments (within the HVAC Energy Primer CD and at the HVAC portion of <http://www.ecoadvisor.com>). An illustrative example is shown in Figure 2, providing system status and feedback on actions taken. Likewise, the underlying simulation structure is already implemented in SPARK. Thus, this CBE tool will be developed very-cost-effectively for this project, starting from well-developed existing products. The challenge for this effort is to refine, extend and merge the existing elements most effectively to produce the best possible tool within available resources.

The specific capabilities of the simulation engine help the CBE Tool to support the Laney curriculum objectives include:

Figure 2. GUI and elements of a problem-solving exercise

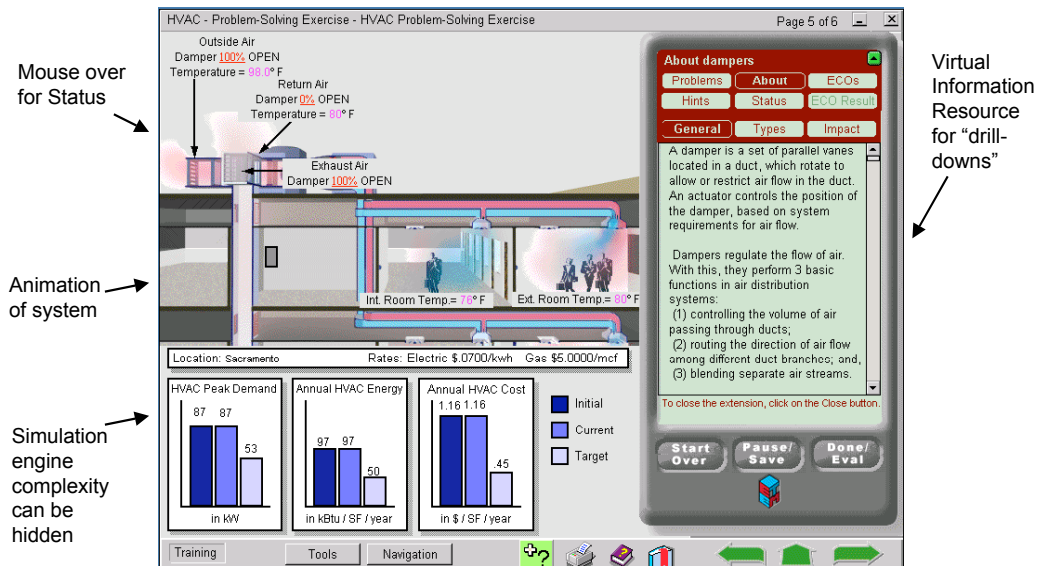

- **Simulating HVAC components:** Independent software-based models already exist for all major HVAC components (Bourdouxhe *et al.* 1994; Haves *et al.* 1998) and most have already been implemented in the SPARK equation-based simulation program. This includes chillers; cooling towers; pumps; fans; coils; terminal boxes; compressors; motors; dampers; valves; and actuators.

Figure 3 depicts an illustrative VAV control system that will be part of the CBE tool.

Figure 3. VAV control simulator example: hybrid software-hardware configuration

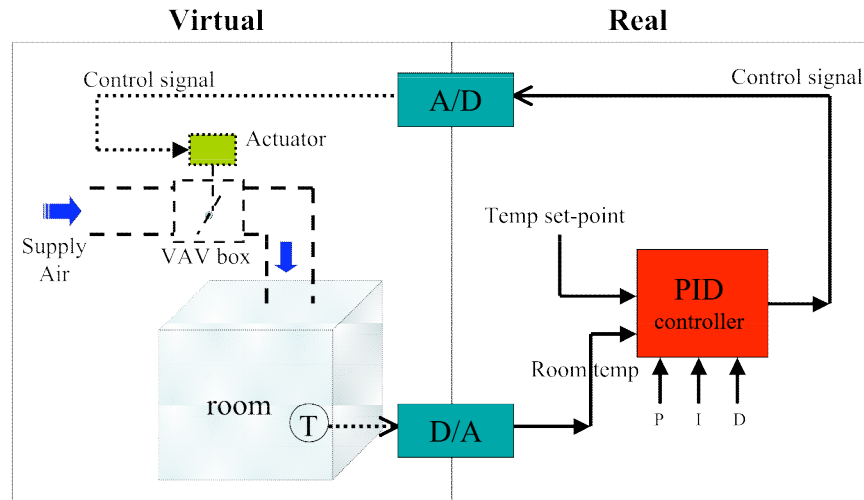

- **Simulating Control of HVAC Components:** The CBE tool will contain models of control functions for each HVAC component model within SPARK in order to simulate typical HVAC control loops (Haves *et al.* 1998). The simulation will be designed for two modes of use: (1) A *virtual* mode in which both the HVAC system and the controls for it are completely resident in software, and (2) a *hybrid* mode in which the controls are a “real” hardware interface to commercial control system components (Haves *et al.* 1991). Several HVAC control system manufacturers have agreed to donate equipment for use in the project. A prototype hybrid simulator has been developed at LBNL and will be used as the starting point for the development of a compact simulator that can be implemented as a simple extension to the personal computers in a computer-teaching laboratory.
- **Simulating System-level HVAC performance and control:** An HVAC simulation-based learning environment has the key advantage of offering a relatively low-cost, and low-risk, method of allowing students to explore and understand a range of behaviors of large and complex HVAC systems typically found in commercial buildings. It is usually impractical and prohibitively expensive to provide students with either laboratory or real environments for studying such problems. Also, if a student makes a serious error during a simulation, they can restart the simulation; but the same error on real equipment might cause damage. The exercises will be structured to allow students to handle progressively more complex problem situations as their learning and skills increase.
- **Diagnostics:** Testing and diagnosing building systems builds upon students’ understanding of the behavior of both components and systems. Simulation-based exercises will demonstrate the symptoms of faulty operation, ideally in relation to laboratory exercises using real equipment. Simulation-based exercises using blind faults can be used to develop and test students’ diagnostic abilities. A number of such extended component models have previously been developed by one of the authors (Haves 1997) and these extended models will be implemented in SPARK and/or EnergyPlus in order to allow the component and system simulations described above to treat faulty operation.

Outreach and Articulation with Pre-College Programs and 4-year Colleges

The existing Laney program serves approximately 50 new students each year. This number will be increased considerably to 600 students over three years via the following articulation and outreach activities:

- (1) We will support faculty-student teams from institutions across the country to participate in research experiences that expose them to advances in building energy sciences and career opportunities as building operators and technicians and build leadership at community colleges for curricular improvements.
- (2) We will educate and support community college faculty and students at colleges with environmental controls technology associate degree programs so they can use the updated curriculum including innovative tools and methods developed through this partnership. Fresno City College, Los Medanos College, San Jose City College, and Southern and Northern Maine Community Colleges have already committed to participating.
- (3) We will provide mentored summer research experiences in the building sciences at Berkeley Lab for students completing environmental control technology associate degree programs and interested in pursuing degrees at four-year institutions.
- (4) We will develop and implement a standards-based physics course that provides high school students with concurrent credit at Laney College and Oakland Unified School District. Developed in collaboration with high school teachers, the course will provide substantial instruction in core physics concepts wrapped around hands-on experiences in environmental controls and technology and will introduce students to careers in environmental control technologies and energy-efficient building sciences.

Community College Faculty and Student Internships: Faculty student teams have proven to be an effective way to update both community college faculty and students through participation in the research programs at Berkeley Lab through the Center for Science and Engineering Education. One objective of the program is to establish an ongoing partnership between the Berkeley Lab investigators and the community college faculty. Seven teams (with three teams returning from 2002) participated in the summer of 2003. Recruitment and selection of environmental control technology faculty for FaST appointments at Berkeley Lab will target potential regional leaders for the dissemination of the Environmental Control Technology programs innovative curriculum and tools. One team will be supported each summer under the DOE-NSF partnership FaST program. The faculty member will recommend two students to join a research group for a 10-week assignment at Berkeley Lab in the energy efficient buildings program. Faculty participants will participate in collaborative research and help field test the curriculum.

Community College Field Test Faculty Workshops: Workshops for community college faculty responsible for environmental control technologies programs will introduce successful innovative tools and methods piloted at Laney College. Faculty interested in updating their curricula will be targeted through mailings and the web. The first workshop to promote the dissemination of the tools will be held in the summer of 2005.

Mentored Research Internships for Students from Four-Year Institutions: We expect that a number of students in the Laney College program and at field test sites would be interested in pursuing four-year degree opportunities in the building sciences. Two strategies are planned.

The first is to provide 10-week summer or 15-week academic semester internships for these students at Berkeley Lab in the energy efficient buildings program. The second strategy is to develop articulation agreements with four-year institutions. A number of four-year colleges and universities have been identified and have expressed an interest in graduates of the expanded environmental control technologies program.

Physics Course for Pre-college Outreach and Academic Support: High school graduates from Oakland schools who enroll in Laney's ECT program often lack academic preparation in the principles of physics. A second issue is that many high school students are unaware of the career opportunities as building operators and technicians. We will address these issues by developing a 90-hour summer course to teach physics using the ECT lab at Laney College supplemented by special activities at Berkeley Lab. The course will be developed collaboratively with the participation of high school physics teachers from the Oakland Unified School District (OUSD). The course will be taught as a three-week summer institute for high school students. Students will receive one-year equivalent credit to fulfill the three-year science requirement for graduation. Teacher professional development and academic year support will be provided to encourage recruitment of students for the summer institute who are likely to continue in the Laney College ECT program. Over 70% of the students from Oakland Unified School District, with which there will be articulation agreements, are underrepresented minorities in the fields of science and technology. Course content will be standards-based. Both problem- and project-based methods of instruction will be used. Local high school teachers will develop the course in the first year during a summer 2004 workshop that will include participation of the Berkeley Lab scientists and Laney College faculty. One or more of these same teachers will participate as instructors during the summer concurrent enrollment physics course.

Replicability & Sustainability

Sustainability of the project is assured insofar as Laney College has made a commitment to implement the curriculum developed under the project. Moreover, all curriculum and tools developed will be made available at no charge to other learning institutions. Through outreach activities, community college teachers around the country will become familiar with the material. New courses and computer-based tools will be highly portable, test site colleges will not only try out the curriculum and tools but will also provide valuable feedback to the project on ways to enhance these project work products. Our use of the simulator approach to education will bring the benefits of laboratory-type experiences to students, without the high cost and other complications associated with establishing physical laboratories. This factor will in itself speed diffusion of the material to other colleges. Moreover, the software will be published in "open-source" format, so that others can obtain and modify the program to meet their own needs. This strategy avoids any proprietary or other economic barriers to diffusion.

Conclusions

The initiative described here will help community college education catch up with the rapidly changing technical and economic realities of building energy management. The broader impacts of the project include: providing high-level technical and analytical skills

acutely needed by technicians in this field; raising the diversity and status of technicians, significantly improving and expanding existing curriculum, methods, and tools for local use and widespread dissemination; synchronizing the community college program with the frontier of research in this field; providing faculty development at a scientific research laboratory; and addressing the need for a significantly larger workforce with the skills to improve operational efficiency of buildings and saving energy while ensuring high indoor environmental quality and improving the productivity of building occupants.

References

- Bourdouxhe, J-P.H., Grodent, M., Lebrun, J., Saavedra, C. 1994a. "A Toolkit for Primary HVAC System Energy Calculation - Part 1: Boiler Model". *ASHRAE Trans.* Vol.100, Part 2, 759-773.
- Bransford, J. A. L. Brown, R. R. Cocking (eds). 1999. *How People Learn: Brain, Mind, Experience, and School*. National Research Council, Committee on Developments in the Science of Learning, 346pp. See <http://www.nap.edu/catalog/6160.html>
- Carnevale, A.P. 1991. *America and the New Economy: How New Competitive Standards Are Radically Changing American Workplaces*, Jossey-Bass Publishers, San Francisco.
- Grubb, N. 2000. "Issues and Linkages for an Information-Based Workplace," in *Learning Now: Skills for an Information Economy*, S. Rosenfeld (ed.), Community College Press, Washington D.C.
- Haves, P. 1997. "Fault Modelling in Component-based HVAC Simulation," *Proceedings of Building Simulation '97*, Prague, Czech Republic.
- Haves, P., Dexter, A.L., Jorgensen, D.R., Ling, K.V., and Geng, G. 1991. "Use of a Building Emulator to Develop Techniques for Improved Commissioning and Control of HVAC Systems," *ASHRAE Trans*, **97**, Pt 1.
- Haves, P., Norford, L.K., and DeSimone, M.. 1998. "A Standard Simulation Testbed for the Evaluation of Control Algorithms & Strategies," *ASHRAE Trans*, **104**, Pt 1.
- Mahoney, J.R., Barnett, L. 1998. *Developing Technicians: Successful International Systems*, Community College Press, Washington DC.
- PETE and ATEEC. 2000. "Energy Services Careers". Partnership for Environmental Technology Education and Advanced Technology Environmental Education Center, Bettendorf, Iowa.
- Sowell, E.F., and Haves, P. 2001. "Efficient Solution Strategies for Building Energy System Simulation." *Energy and Buildings*, **33**, 309-317.
- Wiggins, G. and McTighe, J. 1998. *Understanding by Design*. ASCD, Alexandria, Virginia.