

Lawrence Berkeley National Laboratory

Lawrence Berkeley National Laboratory

Title

The TE Wave Transmission Method for Electron Cloud Measurements at Csr-TA

Permalink

<https://escholarship.org/uc/item/9819s1kd>

Author

Desantis, S.

Publication Date

2009-05-04

Peer reviewed

THE TE WAVE TRANSMISSION METHOD FOR ELECTRON CLOUD MEASUREMENTS AT CESR-TA*

S. De Santis[#], J. Byrd, LBNL, Berkeley, CA 94720, U.S.A.
J. Sikora, M. Billing, CLASSE, Ithaca, NY 14853, U.S.A.

Abstract

We report on the optimization of TE Wave measurements at the Cesr-TA ring at Cornell University. The CESR storage ring is currently used as a test bed for technologies to be used in the damping rings of the International Linear Collider. The TE Wave measurement method utilizes capacitive buttons (BPMs) in the ring to excite and detect a propagating electromagnetic wave corresponding to the beampipe's fundamental TE mode. The presence of low-energy electrons along the wave path changes its propagation characteristics, which can be detected by analyzing the received signal. By choosing the machine fill pattern (gaps and bunch trains length) it is possible to modulate the density of the electron cloud and derive information on its rise and fall times by observing the detected signal spectrum. The possibility of circulating both electron and positron beams in the ring enabled us to separate the contribution of primary photoelectrons, which are independent on the circulating particle nature, from the transverse resonant mechanism, which can increase the primary electron density many times over and which only takes place with a circulating positron beam.

INTRODUCTION

The study of the electron cloud effect, its measurement and mitigating techniques experimentation, constitutes one of the main activities in the Cesr-TA research program [1]. Several techniques have been proposed, and implemented to some level, in order to characterize the electron cloud density (ECD) [2-5]. In this paper we present the initial results obtained using the TE transmission technique described in Ref.5. This technique offers the advantage of being easily implemented in any sector of an accelerator where BPM's are available, therefore not requiring any dedicated installation. Other techniques (RFA, witness bunch, and shielded pick-up, in the near future) are being simultaneously used on Cesr-TA and the comparison of results obtained can be usefully applied to a better understanding of each individual method peculiarities and for crosschecks.

Besides the TE transmission method in its initial formulation, we also present some results obtained with two alternative procedures, the so called "resonant BPM" and direct phase measurement, which can possibly help in circumventing some problems encountered in the

application of the traditional scheme using a propagating wave.

A general theory and the principles behind a practical realization of this method are illustrated in [5]. Ordinary BPM buttons are used to excite a propagating TE wave in the beampipe, below the cut-off frequency of the first high-order mode, and to detect the signal at some distance along the accelerator. By measuring the phase delay of the wave it is possible to infer the maximum value of the ECD, averaged along that portion of beampipe.

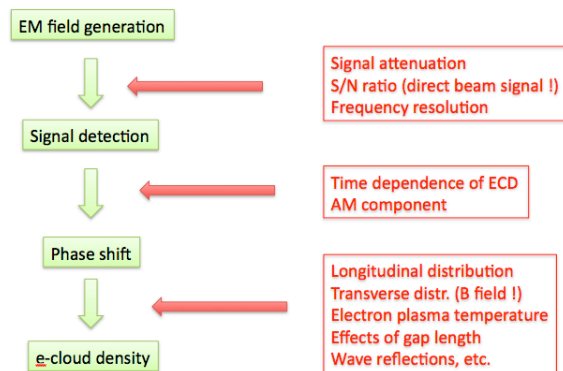

Figure 1. Block diagram of a TE wave measurement procedure, with its sources of error/uncertainty.

While, conceptually, this is a rather simple technique, the actual calculation of a good estimate for the ECD is not a trivial endeavour, due to peculiarities of the electron cloud phenomenon and of the electromagnetic environment in a real accelerator itself.

In Fig.1 we show the four basic steps in the measurement procedure and a number of elements that affect a final evaluation of the ECD. Some of them can be taken care of with ordinary methods, while the effect of others is still an open question and require further studies and a refinement of the experimental procedure, if one wants to obtain more and more precise measurements.

Overall, the method is already at a stage where its results have certainly an absolute qualitative validity and can definitely compete with other experimental procedures, from a quantitative point of view.

EXPERIMENTAL SETUP IN THE CESR-TA RING

Two different areas of the Cesr ring have been used for the initial measurements: a 4 meter long pipe section running inside a dipole magnet and a 17.6 meter straight

* Work supported by the U.S. Department of Energy under Contract No. DE-AC02-05CH11231.

[#] sdesantis@lbl.gov

around the former CLEO interaction region, which is currently occupied by six wiggler modules. In this second region an extra BPM set is available at mid-length in addition to the two sets at the region extremities (East and West). This set was used as the signal input port, to propagate the TE wave towards the East and West end BPM's, thus allowing us to compare the two halves of the straight, and also as the single port used in the resonant BPM scheme illustrated later on in this section.

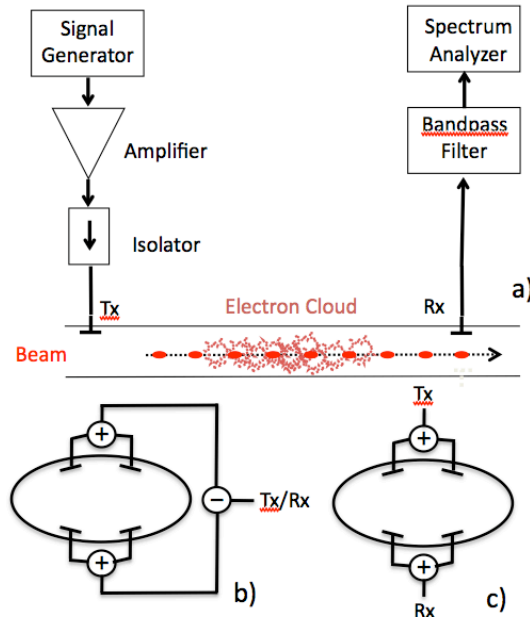

Figure 2. a) Instrumentation setup b) Button arrangement for transmission measurements c) Button arrangement for "resonant BPM" scheme.

The standard setup for transmission is shown in Fig.2. Two separate BPM modules are used, one for exciting the TE wave (Tx) and the other for its detection (Rx). Fig.2b shows how the individual buttons in each module are connected, in such a way to increase coupling to the TE mode and, instead, minimize coupling to the circulating beam signal.

Resonant BPM

An element of uncertainty connected to the traditional transmission method is to be found in the actual propagation of the wave: rather than simply travelling from the transmitter to the receiver BPM, it is conceivable that reflections from discontinuities in the vacuum chamber may reflect back into the receiver BPM waves that have travelled substantially farther, either upstream from the transmitter, or downstream from the receiver.

The so-called resonant BPM scheme (Fig.2c) is immune to this effect. A single BPM module is used, with a pair of buttons connected to the transmitter and the opposite pair connected to the receiver. By using a carrier frequency slightly below the beampipe cutoff a trapped mode is generated in a portion of vacuum chamber around the BPM: It can be shown that pipe and the BPM act as a resonant cavity and the overall signal loss between

transmitter and receiver is small. The trapped mode does not propagate and its extension into the pipe, away from the BPM can be increased or decreased by slightly changing the generator frequency. We show in the next section that this electromagnetic field is also sensitive to the ECD level, although we are still working on a complete analytical model of this configuration and we don't have yet quantitative measurements.

Direct phase measurements

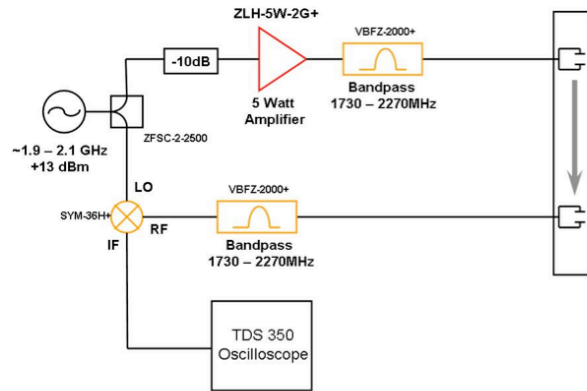

Figure 3. RF mixing circuit used for direct measurements of the phase delay.

Figure 3 shows the hardware used to realize a direct measurement of the TE wave phase delay. The generated signal is split and used as a reference for the received signal. The IF output of the mixer is observed on an oscilloscope and, not shown in figure, a trombone is used to change the phase of the LO mixer input. While the frequency domain measurement can only measure the magnitude of the phase delay, this setup allows to also determine its sign. We will see how this is an important factor when a direct phase measurement is used in the resonant BPM.

MEASUREMENTS RESULTS

Transmission measurements

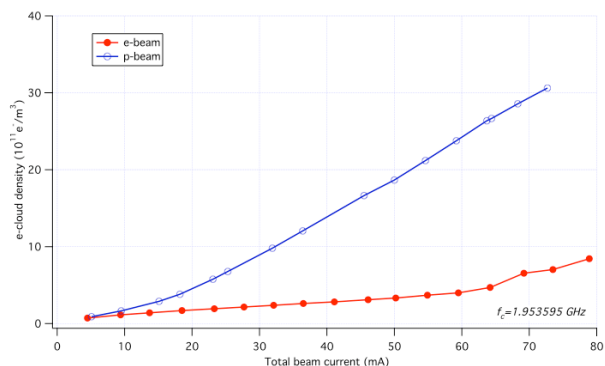

Figure 4. Transmission measurements in the dipole region. 45-bunch train positron and electron beam.

A special feature of the Cesr-TA ring is the availability of both electron and positron beams, which circulate in opposite directions. We have therefore performed measurements with both beams in order to separate the contribution of primary photoelectrons to the ECD. Figure 4 shows the difference in the measured ECD generated by a 45-bunch train of electrons or positrons (14 ns bunch spacing), as a function of total beam current.

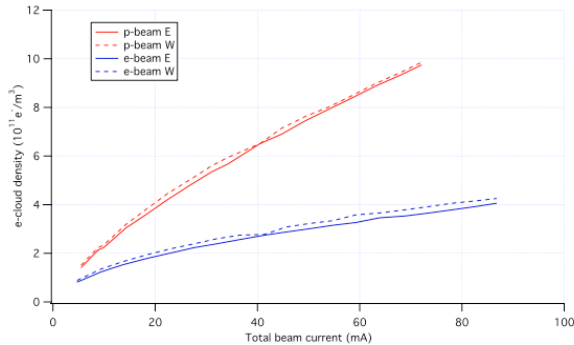

Figure 5. Transmission measurements in the CLEO wiggler straight. Central BPM to East end (solid) and to West end (dashed).

An example of measurements in the CLEO straight is given in Fig.5: once again, as the current increases, the positron beam generates substantially more low-energy electrons due to the transverse resonant extraction mechanism typical of the electron cloud. There is basically no difference in the ECD measured in the East and West halves of the straight, which in fact have very similar beampipe geometries.

Resonant BPM measurements.

The centre BPM in the CLEO straight has also been used to try the resonant BPM procedure detailed above.

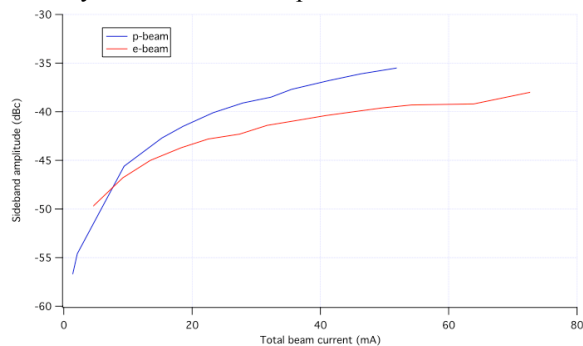

Figure 6. First sideband amplitude measured with the resonant BPM with positron and electron beam.

With this scheme also modulation sidebands are generated when the beam current increases. In Fig.6 we report the amplitude of the first sideband relative to the carrier. At this point only qualitative considerations are possible (once again the positron beam generates larger sidebands) due to the lack of a definitive analytical model, which we are currently developing. By mixing the transmitted signal with the received one it is possible to measure their relative phase shift and study how this

depends on the beam conditions. Again, deriving a value for the ECD from the measured phase shift needs a more thorough understanding of the physics of this particular methodology. Figure 7 is an example of our first results: phase shift is proportional to the measured voltage and once can see how it increases during the bunch passage and decays afterwards.

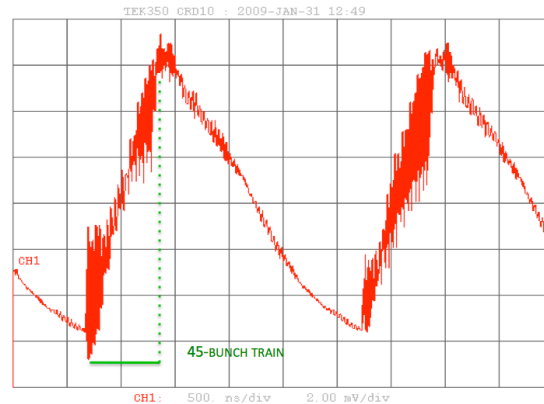

Figure 7. Example of direct phase measurement in the resonant BPM configuration.

SUMMARY

We have presented the first measurements of the electron cloud density in two regions of the Cesr-TA ring performed using the TE wave transmission measurement. We have identified a number of issues in the quantitative determination of the ECD based on this method and are working on eliminating as many uncertainties as possible. To this end we have conceived an alternative configuration for the measurement setup.

Experimental results, with an estimate of the ECD have been obtained with both positron and electron beams, in a variety of fill configurations and current values.

REFERENCES

- [1] M. Palmer, et al. "Plans for Utilizing the Cornell Electron Storage Ring as a Test Accelerator for ILC Damping Ring", in Proc. of PAC07, p. 42 (2007).
- [2] R. Rosenberg and K. Harkay, "A Rudimentary Electron Energy Analyzer for Accelerator Diagnostics", NIM-A 453, 507 (2000).
- [3] E. Mahaner, T. Kroyer and F. Caspers, "Electron Cloud Detection and Characterization in the CERN Proton Synchrotron" PRST-AB 11, 094401 (2008).
- [4] M. Kireeff Covo, et al. "Absolute Measurements of Electron Cloud Density" in Proc. of PAC07, p. 754 (2007).
- [5] S. De Santis, J Byrd, et al. "Measurement of Electron Cloud in Large Accelerators by Microwave Dispersion", PRL 100, 094801 (2008).

This document was prepared as an account of work sponsored by the United States Government. While this document is believed to contain correct information, neither the United States Government nor any agency thereof, nor The Regents of the University of California, nor any of their employees, makes any warranty, express or implied, or assumes any legal responsibility for the accuracy, completeness, or usefulness of any information, apparatus, product, or process disclosed, or represents that its use would not infringe privately owned rights. Reference herein to any specific commercial product, process, or service by its trade name, trademark, manufacturer, or otherwise, does not necessarily constitute or imply its endorsement, recommendation, or favoring by the United States Government or any agency thereof, or The Regents of the University of California. The views and opinions of authors expressed herein do not necessarily state or reflect those of the United States Government or any agency thereof or The Regents of the University of California.