

# Lawrence Berkeley National Laboratory

## Lawrence Berkeley National Laboratory

### **Title**

PERFORMANCE OF RESIDENTIAL AIR-TO-AIR HEAT EXCHANGERS: TEST METHODS AND RESULTS

### **Permalink**

<https://escholarship.org/uc/item/0kh846cf>

### **Author**

Fisk, William J.

### **Publication Date**

1980-09-01



# Lawrence Berkeley Laboratory

UNIVERSITY OF CALIFORNIA

## ENERGY & ENVIRONMENT DIVISION

PERFORMANCE OF RESIDENTIAL AIR-TO-AIR HEAT  
EXCHANGERS: TEST METHODS AND RESULTS

William J. Fisk, Gary D. Roseme, and  
Craig D. Hollowell

September 1980

RECEIVED  
LAWRENCE  
BERKELEY LABORATORY

MAY 21 1981

LIBRARY  
DOCUMENTS

### TWO-WEEK LOAN COPY

*This is a Library Circulating Copy  
which may be borrowed for two weeks.  
For a personal retention copy, call  
Tech. Info. Division, Ext. 6782*



LBL-11793  
c. 2

## DISCLAIMER

This document was prepared as an account of work sponsored by the United States Government. While this document is believed to contain correct information, neither the United States Government nor any agency thereof, nor the Regents of the University of California, nor any of their employees, makes any warranty, express or implied, or assumes any legal responsibility for the accuracy, completeness, or usefulness of any information, apparatus, product, or process disclosed, or represents that its use would not infringe privately owned rights. Reference herein to any specific commercial product, process, or service by its trade name, trademark, manufacturer, or otherwise, does not necessarily constitute or imply its endorsement, recommendation, or favoring by the United States Government or any agency thereof, or the Regents of the University of California. The views and opinions of authors expressed herein do not necessarily state or reflect those of the United States Government or any agency thereof or the Regents of the University of California.

LBL-11793  
EEB-Vent 80-18

PERFORMANCE OF RESIDENTIAL AIR-TO-AIR HEAT EXCHANGERS:  
TEST METHODS AND RESULTS

William J. Fisk, Gary D. Roseme and Craig D. Hollowell

Energy Efficient Buildings Program  
Energy and Environment Division  
Lawrence Berkeley Laboratory  
University of California  
Berkeley, California 94720

September 1980

This work was supported by the Assistant Secretary for Conservation and Solar Energy, Office of Buildings and Community Systems, Buildings Division of the U.S. Department of Energy under Contract no. W-7405-ENG-48.

A condensed version of this report will be presented at the First International Energy Agency Conference on New Energy Conservation Technologies and Their Commercialization, Berlin, Germany, April 6-10, 1981.



TABLE OF CONTENTS

Introduction . . . . . 1

General Description of Air-to-Air  
Heat Exchangers . . . . . 3

Installation of Residential Heat Exchangers . . . . . 4

Heat Exchanger Performance . . . . . 4

Heat Exchanger Test Facility . . . . . 13

Testing Procedure. . . . . 23

Mass and Energy Balance Ratios  
from Test Data . . . . . 25

Methods of Presenting Test Results . . . . . 26

Heat Exchanger Descriptions and Test Results . . . . . 28

Conclusions . . . . . 38

Acknowledgements . . . . . 39

References . . . . . 40

Table 1 . . . . . 42

Figures . . . . . 43



## ABSTRACT

The Lawrence Berkeley Laboratory has constructed a facility for testing various performance aspects of residential air-to-air heat exchangers. When used in conjunction with a mechanical ventilation system, a heat exchanger permits adequate ventilation with outside air while recovering most of the energy normally lost when no heat exchanger is used. By constructing or retrofitting a home to lower the natural infiltration rate, and installing a heat exchanger-ventilation system, a homeowner can save energy, reduce heating and cooling costs, and prevent the buildup of indoor-generated air contaminants.

In this paper we present the test results obtained on five different residential heat exchangers and describe the performance criteria, the test facility, and the test procedures used. The performance parameters measured were heat exchanger effectiveness (a measure of heat transfer ability), airstream static pressure drop, net cross-stream leakage, and fan system performance. The performance of the five heat exchangers differed greatly. The ability to transfer heat ranged from 43 percent to 75 percent of the theoretical maximum. The resistance to air flow varied by a factor of two. One of the heat exchangers was highly susceptible to leakage between airstreams and one had an unstable performance. In the future, additional heat exchangers will be tested, a new test system will be used to measure cross-stream leakage, and the possibility and consequences of freeze-up within the heat exchangers will be investigated.

keywords: air-to-air heat exchanger, energy recovery, heat recovery, indoor air quality, mechanical ventilation, performance testing, residential buildings.





## INTRODUCTION

### Lawrence Berkeley Laboratory Heat Exchanger Program

The heat exchanger program at LBL was initiated in October, 1978. The program focuses on three main areas of investigation: the cost-effectiveness of heat exchangers as an energy-conservation measure, field testing in residences located throughout the United States, and laboratory testing of commercially available units.

We have shown in a preliminary economic analysis<sup>1</sup> that constructing an airtight house and installing an air-to-air heat exchanger is a cost-effective energy-conservation measure in many areas of the United States. This economic analysis will be updated as we accumulate more data from our field and laboratory testing.

In the field project being undertaken during the winter of 1980-81, we will install air-to-air heat exchangers in a number of homes throughout the United States and measure pollutant concentrations versus ventilation rate as well as actual operating problems encountered in installed units.

Our laboratory studies have focussed on measuring the thermal performance and fan performance of commercially available air-to-air heat exchangers.

### Rationale for Residential Mechanical Ventilation with Heat Recovery

In the past most homes have relied on the leakage of air into and out of the structure for ventilation. Residences were and are still being built that are not well sealed against the infiltration of outside air into the structure. Recently, however, because of high energy costs and recognition that the infiltration of outside air constitutes a large fraction of the heat load of a house, some builders are developing and implementing procedures to reduce the influx of outside air.<sup>2,3,4</sup> In some homes, natural air infiltration rates have been reduced to as low as 0.1 to 0.25 air changes per hour (ach), even during severe weather,

by installing high-quality windows and doors as well as plastic air/vapor barriers in the outside walls and ceilings, and by caulking and sealing plumbing, electrical and other penetrations to the outside. By reducing the infiltration of outside air and constructing well insulated houses, builders have greatly reduced the energy required for heating and cooling. Unfortunately, this reduction of outside air entering the structure can lead to problems with the quality of the indoor air. In tightly sealed homes, humidity can rise to uncomfortable levels because the moisture generated indoors from occupants, cooking, bathing, and groundwater in basements cannot escape fast enough. High levels of indoor-generated pollutants have been found in some of these homes -- NO<sub>2</sub> from gas appliances, radon gas from the soil surrounding building basements and foundations, and formaldehyde from building materials, furnishings and some types of insulation.<sup>5</sup>

One means of alleviating these air quality problems, without sacrificing all of the gains of energy-conserving measures, is to install a mechanical ventilation system that incorporates an air-to-air heat exchanger. An air-to-air heat exchanger is a device that brings two airstreams of differing temperature into thermal contact for the purpose of transferring the heat between them. This process is accomplished by breaking the larger incoming airstreams into many smaller streams and constructing the unit so that on either side of each cold airstream there is a hot stream and vice versa. In winter, cold outside air is brought into the exchanger where it is warmed by the heat transferred to it from the warm air that is exhausted from the house. In summer the heat exchanger can cool and, in some cases, dehumidify the hot outside air that is passed through it and into the house for the purpose of ventilation. By providing controlled ventilation, this system flushes out indoor-generated pollutants. While many general and specific strategies can be used to control indoor air quality problems (filters, air washers, electrostatic air cleaners, etc.), in this report, we will address only the use of mechanical ventilation with air-to-air heat exchangers for energy-efficient indoor pollution control.

The essential aim of this report is to describe the results obtained on performance tests of five commercially available air-to-air heat exchangers used in residential mechanical ventilation systems. The description of our findings is preceded by general background information on the design and installation of heat exchangers, our test facility, and the criteria and methods used for these performance tests.

#### GENERAL DESCRIPTION OF AIR-TO-AIR HEAT EXCHANGERS

Heat exchangers are generally classified by their flow configuration. In a counterflow exchanger (Figure 1) the hot and cold airstreams flow parallel to one another but in opposite directions. A similar type of heat exchanger is the parallel-flow exchanger in which the hot and cold airstreams flow in the same direction. In a crossflow exchanger, (Figure 2) the flow paths are perpendicular to one another.

Another type of heat exchanger is a heat wheel (Figure 3). In this type of exchanger, the air flows are generally in opposite directions with the cold and hot airstreams each flowing through one half of the wheel. The wheel slowly revolves on its axis and, as the part of the wheel that has been heated by the hot stream turns into the cold stream, it heats the air and then turns into the hot stream again to adsorb more heat.

Many other types of heat exchangers are available in large sizes for commercial and industrial use. Some heat exchangers are designed to transfer water vapor as well as heat from one airstream to the other. The advantages and disadvantages of the transfer of water vapor are discussed later in this report.

The part of the heat exchanger where the heat is actually transferred is called the core of the exchanger. Heat exchanger cores are made from a number of different materials such as metals, plastics, and treated paper. Some manufacturers supply small ventilation/heat exchanger systems containing a core, fans, and filters all mounted in an insulated sheet-metal case. Other manufacturers supply just a core.

## INSTALLATION OF RESIDENTIAL HEAT EXCHANGERS

Mechanical ventilation systems using air-to-air heat exchangers can be installed in a number of different ways. Figure 4 shows a window- or wall-mounted unit that is installed much like a window air conditioner. Figure 5 shows an attic installation where the unit is connected to an extensive duct work system that draws stale air from the kitchen, bathroom, and utility room of the house and distributes the warmed outside air to the bedrooms and the living room. This type of system is generally more expensive because of the extensive duct work required. In the United States, where central forced air heating and cooling systems predominate, the existing duct systems can be utilized. In these homes, the conditioned outside air from the heat exchanger can be supplied to the return duct for distribution.

When installing a ducted heat exchanger system, damper valves should be placed in each duct so that the air flow rates can be adjusted and balanced. Suitable equipment to measure the air flow rates (such as a pitot tube and sensitive pressure gauge) is required to adjust the flow rates.

Other factors related to the installation of heat exchangers, such as insulating the heat exchanger and ducting, providing drains for condensate, and balancing the airstream flow rates, are discussed in the following section on heat exchanger performance.

## HEAT EXCHANGER PERFORMANCE

In a residential heat exchanger, leakage of air, condensation and freezing of water vapor, internal heat sources (such as fan motors), and heat transfer to and from the surroundings all affect performance. The effect of each of these factors is discussed later in this report. In a classical (textbook) analysis of a heat exchanger, none of these complications is considered and performance is characterized by "heat exchanger effectiveness," as defined below.

## Theoretical Performance Criteria

Heat exchanger effectiveness is defined as the ratio of actual heat transfer to that which is theoretically possible--i.e., the heat transfer that would occur in an infinitely large counterflow heat exchanger.

The heat transfer that occurs between the two airstreams in a heat exchanger causes each airstream to change temperature. The airstream with the smallest capacitance undergoes the greatest temperature change. (Airstream capacitance is defined as the product of the airstream mass flow rate and airstream specific heat and can be considered the thermal inertia of the airstream.) In an infinitely large counterflow heat exchanger, the minimum capacitance airstream changes from its initial temperature to the inlet temperature of the other airstream, and heat exchanger effectiveness is 100 percent. In a real (finite size) heat exchanger, the effectiveness equals the ratio of the temperature change of the airstream with the smallest capacitance to the temperature difference between the two entering airstreams. The equation for effectiveness is:

$$\epsilon = \frac{\Delta T'}{(T_{hs} - T_{cs})} \quad (1)$$

where:

$\Delta T'$  = the temperature change of the minimum capacitance airstream

$T_{hs}$  = the temperature of the hot airstream supplied to the heat exchanger

$T_{cs}$  = the temperature of the cold airstream supplied to the heat exchanger

If the heat exchanger effectiveness and the two inlet airstream temperatures are known, Equation 1 can be used to calculate the temperature change of the minimum capacitance airstream.

If the airstream entering the residence does not have the minimum capacitance, then the effectiveness will not directly characterize the temperature change of the air supplied to the residence. However, if no condensation occurs in the core of the heat exchanger and if the leakage of air (cross-stream leakage and leakage to and from the surroundings) is small, the temperature change of the two airstreams in a heat exchanger can be related by the equation

$$(\dot{m}C_p\Delta T)_{\text{HOT}} = (\dot{m}C_p\Delta T)_{\text{COLD}} \quad (2)$$

where:  $\dot{m}$  = the airstream mass flow rate

$C_p$  = the airstream specific heat at constant pressure

$\Delta T$  = the airstream temperature change

HOT = the hot airstream

COLD = the cold airstream

The ratio  $(\dot{m}C_p)_{\text{HOT}}/(\dot{m}C_p)_{\text{COLD}}$  is called the "capacity ratio" and relates the temperature change of the two airstreams. Ideally, the specific heat in Equation 2 should be the specific heat of the air-water vapor mixture that we commonly think of as air. Actually, the airstream water vapor content has only a small effect on the airstream specific heat.

The effectiveness of a heat exchanger decreases with increasing flow rates due to the smaller airstream temperature changes that occur at high flow rates. Airstream temperatures and humidity have only a minor effect on heat exchanger effectiveness as long as no condensation or freezing occur within the heat exchanger.

The rate of heat transfer "Q" between the two airstreams can be calculated from the effectiveness using the following equation:

$$Q = \epsilon(\dot{m}C_p)_{\text{MIN}} (T_{\text{hs}} - T_{\text{cs}}) \quad (3)$$

where:

$\epsilon$  = the heat exchanger effectiveness

MIN = refers to the minimum capacitance airstream

$T_{hs}$  = the temperature of the hot air supplied to the heat exchanger

$T_{cs}$  = the temperature of the cold air supplied to the heat exchanger

Equation 3 is valid if no condensation occurs within the core, no air leakage occurs, and no heat transfer takes place between the heat exchanger and its surroundings.

### Factors Affecting Actual Performance

Fan Heat. Heat exchanger performance is affected by the quantity of fan heat that is added to the airstreams and the location at which the heat is added. Because the small fans and fan motors used in heat exchangers typically have a low efficiency, most of the electrical energy consumed by the heat exchanger fans is immediately released as heat. The fan heat will cause an increase in the temperature change of the cold airstream; therefore, during winter use, some fraction of the fan's energy consumption is saved and supplied to the residence. To maximize the fraction of fan heat delivered to the residence, the supply air fan (for air supplied to the residence) should be downstream of the heat exchanger core and the exhaust air fan (for air exhausted from the residence) should be upstream of the core. This method of fan placement will cause an imbalance in pressures in the heat exchanger, however, and will promote cross-stream leakage if the core is not well sealed. (Cross-stream leakage is discussed later in this report.) The fan heat that is saved and delivered to the residence will cost as much per unit of heat as electrical resistance heating, which is an expensive method of home heating. The fan heat also reduces the temperature change of the hot airstream and therefore has a detrimental effect in the summer. In the summer, the optimal location for the fans would be the opposite of that in the winter. An efficient fan system and a heat exchanger with a low frictional resistance to air flow are desirable from an energy-conservation viewpoint; however, the trade-off between fan (and fan



motor) efficiency and initial cost remains to be investigated.

Condensation/Freeze-up. The performance of a heat exchanger will be affected whenever water vapor from the hot airstream condenses as the hot air is cooled in the heat exchanger core. The temperature of the airstreams entering the heat exchanger, the humidity of the hot entering airstream, and the performance of the heat exchanger determine whether condensation will occur. Condensation causes a reduction in the temperature drop of the hot airstream and thus an increase in the average temperature difference between the two airstreams within the heat exchanger core. As a result, the rate of heat transfer between the two airstreams is increased when condensation occurs. Condensation first occurs on the heat exchanger wall (the surface separating the two airstreams) if the wall is below the hot airstream dewpoint temperature. The condensed water will either drain out of the heat exchanger or re-evaporate at some location where the wall temperature is higher than the dewpoint temperature. Condensation in the airstream will occur if the airstream is cooled to below its dewpoint temperature.

If condensation occurs during the winter season, it will occur in the air being exhausted from the house, and the temperature change of the cold airstream entering the house will be increased. This beneficial effect can be significant if the house air is fairly humid, the outside air is cold, and the heat exchanger is effective.

An examination of weather data for the United States<sup>6</sup> indicates that condensation will occur only rarely during summertime use of a heat exchanger. When condensation does occur in the summer, it can prevent the large temperature reductions in the incoming airstream, which are desirable; however, an advantage is that undesirable water vapor will be removed from the incoming airstream.

A heat exchanger should be provided with an outlet for drainage of condensate (unless it is a type for which this is not required). Typically a condensate drainage line (a length of small diameter tubing) is run from the heat exchanger to a suitable location. This line should not be placed in a location where freezing of the condensed water is possible.

Whenever condensation occurs, the performance of the heat exchanger will depend on the entering air temperature, the entering hot-air humidity, and the airstream flow rates. The effectiveness calculated from the inlet and outlet airstream temperatures is useful only in representing the temperature change that occurs for a specific set of inlet airstream temperatures, humidities, and flow rates. It would take a prohibitively large number of tests to investigate performance for all airstream inlet conditions. One potential method of characterizing heat exchanger performance when condensation occurs is to use a theoretical model for heat exchanger performance. This method is currently being investigated and will be discussed in a future report. All results reported here involve tests where no condensation occurred.

If the outside air temperature is sufficiently below 0 °C (32 °F), condensed water may freeze inside the heat exchanger core and obstruct all or some portion of the airflow. Some of the manufacturers include electric resistance heating elements in their systems to preheat the cold air before it enters the heat exchanger core. Preheating of the cold airstream should be kept to the minimum necessary because it causes a reduction in the amount of energy recovered by the heat exchanger. The consequences of freeze-up and conditions under which it occurs are different for each type of heat exchanger. In general, a more effective heat exchanger may have more freeze-up problems than a less effective heat exchanger. The freeze-up problem will be investigated experimentally and in field trails at a future date.

Cross-Stream Air Leakage. Air leakage can occur between the airstreams in a heat exchanger; this is called "cross-stream leakage". The effect of cross-stream leakage on the measured effectiveness of a heat exchanger depends on the location and amount of the leakage. Air leakage can cause the heat exchanger performance to appear much better than it actually is and, in some cases, the cross-stream leakage cannot be detected by measurements of air flow rates; therefore, the performance results presented in this paper should be considered preliminary until accurate cross-stream leakage measurements can be made. Based upon preliminary test results the amount of cross-stream leakage is expected to be small in most of the heat exchangers.

External Leakage and Heat Transfer. Two other factors that can affect heat exchanger performance are the leakage of air between the heat exchanger and its surroundings and heat transfer between the heat exchanger and its surroundings. For the heat exchangers tested to date, the leakage of air is small and can be easily minimized by taping or caulking the heat exchanger case. Measurements and simple calculations indicate that the magnitude of the heat transfer between the heat exchanger and its surroundings will also be small in most cases, and can be minimized by insulating the heat exchanger. However, the heat transfer between the surroundings and long ducts used to direct the air may be significant unless the ducts carrying air that has a temperature significantly different from the surroundings are well insulated. If the heat exchanger is installed in a heated space, insulation of the heat exchanger and ducts that carry cold air may also be necessary to prevent condensation from their cold external surfaces.

Fouling. An additional factor that may affect heat exchanger performance is the "fouling" of heat-transfer surfaces. If a film of dirt builds up on the heat transfer surfaces, the resistance to heat transfer will increase and the effectiveness will deteriorate. The use of air filters upstream of the heat exchanger core should help to minimize this problem. No direct investigation of this problem has been made for residential heat exchangers.

Ratio of Mass Flow Rates. The ratio of airstream mass flow rates through the heat exchanger affects both the temperature change of the airstream supplied to the residence and the amount of air leakage through the house envelope. If more air is exhausted through the heat exchanger than supplied, the temperature change of the supply airstream will be increased (which is beneficial); however, an amount of air equal to the difference between the exhaust and supply airstream flow rates must leak into the house and be heated or cooled. It will take more energy to heat or cool this air than is saved as a result the increased temperature change of the supply airstream.

In the reverse situation, where more air is supplied through the heat exchanger than exhausted, conditioned (heated or cooled) air will be forced out through the house envelope. Again, this will cause an increase in energy consumption compared to the case of balanced mass flow rates through the heat exchanger.

Unfortunately, in actual use of a residential heat exchanger, it is very difficult to maintain balanced mass flow rates. Changes in air density and viscosity (due to temperature changes), unequal clogging of airstream filters, and freezing within the heat exchanger core inevitably cause imbalances. Because of these imbalances, the energy saved by using a heat exchanger system will not be as high as that indicated by the heat exchanger effectiveness. (Increased heat exchanger performance due to condensation may counteract this effect.) Further study is needed to investigate the magnitude and consequences of flow rate imbalances and to determine whether periodic balancing of flow rates is required.

Transfer of Moisture. Some heat exchangers transfer moisture (water vapor) as well as sensible heat. A Japanese company markets cross-flow heat exchangers with cores made of a special (treated) paper. Water vapor is transferred across the porous paper from the airstream with a high water vapor concentration to that with the lower concentration. In other heat exchangers the hot and cold airstreams alternately flow over the same surfaces. In these units, if water vapor is condensed from the hot airstream when it cools, the water can later re-evaporate in the cold airstream. Still other heat exchangers are constructed from a material that adsorbs water from the high humidity airstream and later releases it to the lower humidity airstream as it passes over the surface.

The ability to transfer water vapor is advantageous during hot humid summer weather. During these weather conditions, air conditioning systems must remove water vapor from the conditioned air, otherwise; very high indoor relative humidity values would result. The energy consumed to remove this water vapor (latent load) can be a very significant portion of an air conditioning system's total energy consumption. A heat exchanger that transfers water vapor can reduce this latent portion of

the air conditioning load as well as precool the incoming air.

In the winter, indoor moisture sources cause the indoor air to have a higher concentration of water vapor than outside air. In very low infiltration residences and in homes that have strong indoor moisture sources, humidity levels can become uncomfortably high and condensation on windows can become a problem. Ventilation through a heat exchanger that does not transfer water vapor is most effective in reducing these high humidity levels.

Some homes have uncomfortably low humidity levels in the winter and, in such cases, humidification is often required. In these homes, ventilation through a heat exchanger that transfers water vapor will help to maintain indoor humidity levels and reduce the need for humidification.

One of the disadvantages of using a heat exchanger that transfers water vapor is that it may also transfer some indoor air contaminants from the exhaust airstream to the airstream entering the residence and therefore be less effective at reducing indoor contaminant levels. Further research is needed to determine the magnitude of this effect in different heat exchangers.

#### Fan System Performance

The total energy performance of a heat exchanger system depends on both the rate of heat transfer within the heat exchanger core and the rate of energy consumption by the fan system. The fan power consumption, for a given air flow rate, depends on the efficiency of the fan and fan motor and the resistance to air flow in the heat exchanger and attached ducting. If the resistance to air flow is high, it will take more fan energy and larger fans to provide a given ventilation rate than when the resistance to air flow is low. To minimize the frictional resistance of the ducting, the duct lengths should be kept as short as possible. In addition, abrupt changes in the cross-sectional area of the duct should be avoided. Diffusers located at the duct inlets and outlets can significantly reduce the energy required to produce a given air flow rate. The characteristics of the duct system immediately downstream of the fan

discharge also can affect the fan performance. Bends or changes in the duct cross sections within five pipe diameters downstream of the fans should be avoided if possible, since they are particularly detrimental to the performance of the fans.

#### HEAT EXCHANGER TEST FACILITY

The Heat Exchanger Test Facility, located in Richmond, CA, currently contains two major systems for testing commercially available heat exchangers: the Thermal Performance Test System and the Fan Performance Test System. These systems will be augmented in the future by a cross-leakage measurement system that uses tracer gas techniques.

##### Thermal Performance Test System

The Thermal Performance Test System is designed to control and measure the pressure, temperature, humidity, and flow rate of the airstreams entering and leaving a heat exchanger. In some cases, the power consumption of the heat exchanger fans and the flow rate of condensed water from the heat exchanger are also measured with this system. These measurements are used to evaluate heat exchanger performance.

Figure 6 shows a side and top view of the Thermal Performance Test System. In this system, air is directed to and from the heat exchanger in sheet metal ducting and 15.2 cm (6 in.) diameter (nominal) PVC ducts. Large centrifugal blowers with one horsepower motors are used to power the air flow. The hot and cold air flows are ducted through two independent flow loops. Each flow loop consists of a supply side (for air supplied to the heat exchanger) and a return side (for the return of air to the blowers). The ducting in the central portion of the test system is made from PVC pipe to facilitate easy installation and removal of the heat exchangers.

In the cold-side flow loop (Figure 7), the air flow rate and pressure is controlled by varying the position of two butterfly valves and one bypass gate valve. Four liquid-to-air cooling coils are installed in the cold side loop to cool the air. A chilled ethylene-glycol and water mixture (coolant) is pumped from a 3.64 m<sup>3</sup> (800 gallon) insulated storage tank through the cooling coils and back to the storage tank. The coolant is chilled in a commercial brine chiller. The chiller draws coolant from and returns it to the storage tank. The use of a large storage tank ensures that the temperature of the coolant supplied to the cooling coils remains stable so that the temperature of the cold air supplied to the heat exchanger will be stable. A three-kilowatt electric heating unit is also installed in the cold flow loop to heat the air if necessary.

In the hot-side flow loop (Figure 8) air enters the blower through an opening for the shaft connecting the motor and the blower. Air is exhausted from the hot-side flow loop through a butterfly valve located in the supply air ductwork. This valve and a second butterfly valve in the return ductwork are used to control the flow rate and pressure in the hot-side loop. Two electric heaters, controlled by voltage regulators, are located in the hot loop and are used to heat the air. A steam humidifier is placed in the hot return ductwork to humidify the hot-side air.

#### Description of Measurement System

For the purposes of measurement, there are four distinct airstreams: two supply airstreams (for air flowing to the heat exchanger) and two return airstreams (for air leaving the heat exchanger). In each of the airstreams, the pressure, humidity, flow rate, and mixed mean temperature are measured.

The volumetric flow rate of the airstreams is measured with orifice plate flowmeters constructed and installed in accordance with American Society of Mechanical Engineers (ASME) specifications.<sup>7</sup> Pressure taps are located one-pipe diameter upstream, and one-half pipe diameter

downstream of the orifices. The airstream pressure drop between these taps is a function of the air flow rate. The pressure drops are measured with large inclined manometers that are calibrated with a sensitive micromanometer. One of three different-sized orifice plates are used, the selection depending on the air flow rate.

The air temperature at the heat exchanger inlets and outlets is measured by means of air-flow mixers and grids of 20-gauge copper-constantan thermocouples. The air-flow mixers subdivide the flow and deflect many small portions of the air in both vertical and horizontal directions. The air mixing assures that the airstream temperature will be nearly uniform at the thermocouple grid. Five thermocouples are placed across the vertical duct diameter. Each thermocouple represents an approximately equal portion of the cross-sectional area of the duct. The thermocouple wires are passed downstream through the air for approximately 30.5 cm (1 ft) before exiting from the ductwork. This arrangement minimizes temperature measurement errors due to heat conduction along the length of the wires. An icebath is used for the thermocouple reference junctions and a digital voltmeter with a one-microvolt sensitivity is used for the voltage readout. The entire temperature measurement system was constructed and then calibrated by comparison to a National Bureau of Standard (NBS) traceable Platinum Resistance Thermometer. Figure 9 illustrates a typical heat exchanger installation showing the location of air mixers, thermocouples, and pressure taps for this installation.

The humidity of the airstreams is measured using a dry- and wet-bulb psychrometer. The dry- and wet-bulb temperature sensors are located in a short section of 7.6 cm (3 in) diameter pipe which is placed in parallel with the 15.2 cm (6 in) diameter pipe as shown in Figure 6. By opening and closing a butterfly valve in the 15.2 cm (6 in) diameter pipe, the air velocity across the dry- and wet-bulb sensors can be controlled. The air velocity is measured with a pitot tube and is maintained at approximately 5.1 m/s (1000 ft/min) as recommended in the Temperature Measurement Standards of the American Society of Heating, Refrigerating and Air-Conditioning Engineers (ASHRAE).<sup>8</sup> At each humidity measurement location, there are two pairs of temperature sensors, each pair



containing a dry- and wet-bulb sensor. One pair of sensors consists of 30-gauge copper-constantan thermocouples with a small brass washer soldered to the thermocouple junction. The use of a brass washer helps to assure good contact between the thermocouple and the wet-bulb wick. The small-diameter thermocouple wire (30 gauge) minimizes temperature measurement errors due to heat conduction along the length of the wire. The thermocouple junctions are held rigidly in place by passing the wires through a two-hole ceramic insulator which is mounted in a rubber stopper. The dry- and wet-bulb thermocouples are used with an icebath reference and a digital voltmeter with a one-microvolt sensitivity. The second set of dry- and wet-bulb temperature sensors consists of precision mercury in glass thermometers with 0.1 °C subdivisions. The thermometers are held in place with rubber stoppers. A commercial cotton wet-bulb wick is used for all of the wet-bulb sensors. The wick material is replaced periodically to prevent errors due to dirt accumulation on the wick.

In many wet-bulb systems the wick material is suspended continuously in a water reservoir. The water diffuses up the wick from the reservoir to the temperature sensor. With such a system it is difficult to ensure that saturation conditions develop at the temperature sensor for all air-flow conditions (temperature, humidity and velocity). In addition, the temperature of the water in the reservoir may affect the indicated wet-bulb temperature. To circumvent these problems, at the test facility, we have used an intermittently wetted wick system, which has yielded much more satisfactory test results (i.e., better water-mass balances) than a previously constructed system utilizing water reservoirs for continuous wetting of the wicks. When the wet-bulb temperature is required, the sensor and surrounding wick is dipped in water and then placed in the airstream. Within a few minutes, a steady-state wet bulb temperature is obtained and this value is recorded.

Pressure taps, used to measure airstream pressure, are located close to the inlets and outlets of the heat-exchangers. Various pressure tap locations are tried with each heat exchanger installation to minimize errors due to tap location. The pressure is measured with calibrated inclined manometers and, in some cases, with a sensitive micromanometer.

Some heat exchanger manufacturers include fan systems with their heat exchangers. For these units, tests are run with and without the fans operating. When the fans are operating, their power consumption is measured with a wattmeter.

In certain tests, not reported here, condensation of water occurs within the heat exchanger and the condensate drips out through a drain. The condensate is collected in a graduated cylinder and the time elapsed during condensate collection is recorded. A condensate flow rate can be calculated from the graduated cylinder reading and the time measurement.

As discussed earlier, the temperature of the air surrounding the heat exchanger can affect its performance because heat can conduct into or out of the heat exchanger case. In most cases the effect is small. At the test facility, the air surrounding the heat exchanger is maintained at approximately 21 °C (70 °F). During testing, the ducting to and from the heat exchanger is insulated; however, the heat exchanger is tested as received from the factory with or without insulation.

#### Capabilities of the Thermal Performance Test System

The maximum air flow rates achievable at the test facility depend on the flow resistance of the particular heat exchanger installed. In most cases, the maximum possible air flow rate is approximately 408 m<sup>3</sup>/hr (240 ft<sup>3</sup>/min), which corresponds to slightly over one air change per hour in a 140 m<sup>2</sup> (1500 ft<sup>2</sup>) house with 2.4 m (8 ft) high ceilings.

The maximum air temperature that can be supplied to the heat exchanger is in excess of 43 °C (110 °F). The humidity ratio of the hot air can be controlled from ambient (room) air levels to saturation conditions. For instance, if ambient air is 21 °C (70 °F) and its relative humidity is 50%, then the relative humidity of supply air with a temperature equal to 35 °C (95 °F) can be controlled between 18 and 100%.

The minimum possible temperature for the cold supply air is 0 °C to 4.4 °C (35 °F to 40 °F) depending on the air flow rate. For the cold supply airstream, the humidity is not controlled and typical relative humidity values vary between 50 and 80 percent. It is not important to control the cold airstream humidity since no condensation can occur in this airstream.

The pressures of the airstreams supplied to the heat exchanger can generally be controlled to any desired value within the range of -1.3 to +1.3 cm of water (-0.5 to +0.5 inches of water), while maintaining the desired air flow rates.

### Accuracy of Measurements

This section discusses the accuracy of the specific measurements made with the Thermal Performance Test System.

Airstream Flow Rate. The accuracy of the orifice plate flowmeters used for measuring airstream flow rate is affected by uncertainties in pressure measurement, pipe diameter, orifice diameter and eccentricity, air viscosity and density, and pressure tap location. In addition, it is critical that the orifice plate be made with a very sharp edge if flow rate measurements are to be accurate. A calculation of the orifice flow coefficient and expansion factor is required for each flow rate measurement. The expected uncertainty in the values of the flow coefficient and expansion factor is published in Reference 7 along with a procedure for estimating the total uncertainty in flow rate measurement. With the recommended technique of error analysis, the uncertainty in the airstream volumetric flow rate measurements was determined to be  $\pm 1.3\%$ .

Airstream Temperature Measurements. Davis, Faison, and Achenbach<sup>9</sup> have examined the errors in the temperature measurement of moving air using thermocouples, thermistors, and thermometers. They demonstrated that maximum errors of 0.11 °C (0.2 °F) are possible even when conditions are almost ideal and great care is taken. The magnitude of these errors could not be explained by predictions of the effects of heat conduction or radiation to and from the temperature sensor, or any other

foreseeable cause. Under less ideal conditions, even larger temperature measurement errors would be likely. An 0.14 °C (0.25 °F) unexplained temperature measurement error was assumed for temperature measurements at the test facility. Two additional sources of temperature measurement error, discussed below, add to the unexplained temperature measurement error.

Thermocouples have a very low voltage output signal. The signal is subject to interference or noise from surrounding electrical equipment as evidenced by small erratic fluctuation in the voltage signal. During testing, signal fluctuations of approximately four microvolts (corresponding to 0.11 °C (0.2 °F) were common; therefore, we assumed an additional temperature measurement error of 0.11 °C (0.2 °F). This problem has subsequently been corrected; therefore, for future measurements this error component will not exist.

It is more difficult to determine the true mixed-mean temperature of an airstream than to make an individual temperature measurement. The airstream leaving some heat exchangers may have large spatial temperature variations (3 ° to 6 °C). Mixing the air just upstream of the thermocouples (used for temperature measurement) reduces the maximum difference between the five thermocouple readings to less than 0.28 °C (0.5 °F) in almost all cases. The error that occurs in mixed-mean temperature measurement because of imperfect knowledge of airstream temperature variations should be less than the maximum indicated temperature variation. Accordingly, a maximum error of 0.11 °C (0.2 °F) attributable to airstream temperature variations is also assumed. By adding the three components of airstream temperature measurement error discussed above, a total maximum airstream temperature measurement error of 0.36 °C (0.65 °F) results. We believe this value represents an over-estimate of the temperature measurement error since, in many cases, the different error components would cancel each other out. Energy balances based on actual test data generally indicate much smaller errors in airstream temperature measurement.

Airstream Humidity Measurements. Dry- and wet-bulb temperature sensors are used in the humidity measurement system at the test facility. Small errors in the dry- and wet-bulb temperature measurements can lead to significant errors in humidity measurement. The dry- and wet-bulb thermocouples used at the test facility have a stable signal that indicates no interference (noise) from surrounding electrical equipment. Accordingly, errors due to signal noise are not a factor in the humidity measurement system. Ideally, the dry- and wet-bulb sensors should be located at the same point. In practice, however, the wet bulb is located a few inches downstream and in line with the dry bulb. Because the sensors are in line, the measurement error due to variations in airstream temperature should be small; an additional error of 0.05 °C (0.1 °F) was thus assumed. If an unexplained temperature measurement error of 0.14 °C (0.25 °F) is added to this (the same unexplained error assumed in airstream temperature measurements), then the total maximum wet- or dry-bulb temperature measurement error is 0.19 °C (0.35 °F). Table 1 illustrates the errors in humidity ratio (the ratio of mass of water vapor to mass of air) and relative humidity that would result, in six different cases, if the dry-bulb temperature measurement is 0.19 °C (0.35 °F) high and the wet bulb measurement is 0.19 °C (0.35 °F) low. As illustrated in this table, the magnitude of the errors in humidity measurement depend on the temperature and humidity of the air.

Other factors that affect the accuracy of a dry- and wet-bulb humidity measurement system include the velocity of the airstream, the rate of conduction and radiation heat transfer to and from the temperature sensors, the characteristics of the wet-bulb wick material, and the purity of the water used to wet the wick. Precautions have been taken at the test facility to minimize the effects of each of these factors (see earlier description of humidity measurement system). Errors in dry and wet bulb temperature measurement should be the dominant source of error in the humidity measurement system.

Airstream Pressure Measurements. The accuracy of the airstream pressure measurements is affected by pressure tap location, tap yaw angles (the angle between the pressure tap and the air flow), the size and shape of the pressure tap, and the accuracy of the pressure measurement device.

At the test facility, a quality commercial static pressure tap is used to eliminate any significant errors due to tap size and shape. As noted earlier, for each heat exchanger installation, a variety of pressure tap locations were tried, each time measuring pressure with a sensitive micromanometer. This procedure minimizes errors due to improper tap location or installation (yaw angle). Based upon the observed difference in pressure measurements at various tap locations, the maximum error in airstream pressure measurement due to tap location and yaw angle is estimated to be 0.013 cm (.005 in) of water. The calibrated manometers used for airstream pressure measurement have a rated accuracy of  $\pm 0.05$  cm ( $\pm .02$  in) of water. By summing the two error components, the maximum error in each pressure measurement is estimated to be 0.063 cm (0.025 in) of water. A sensitive micromanometer can be used in place of the inclined manometers to provide more accurate pressure measurements. With this instrument, the maximum estimated pressure measurement error is 0.018 cm (0.007 in) of water. This procedure has been adopted for future tests.

#### Fan Performance Test System

Some heat exchanger manufacturers include fan systems with their heat exchangers. In some cases the fans are mounted inside a sheet-metal box which also contains the heat exchanger core. In other systems the fans are mounted externally. For a given air flow rate, the energy consumption of the fan system depends on the efficiency of the fans and fan motors, the frictional resistance to air flow in the heat exchanger, and the frictional resistance to flow in the ductwork attached to the heat exchanger.

The performance of the heat exchanger fan system is assessed with the Fan Performance Test System which measures the power consumption of the fans, the airstream flow rates, and the static pressure drop in the piping system attached to the heat exchangers. The static pressure drop is a measure of the flow resistance in the duct system attached to the heat exchanger. The test results can be used to predict the power consumption and airstream flow rates for a heat exchanger system during actual

residential operation, as well as to size the ducting for a particular air flow rate.

Figure 10 presents a drawing of the Fan Performance Test System used at the test facility. As illustrated, air flows to and from the heat exchanger through 10.2 cm (4 in) diameter (nominal) PVC piping. Sheet-metal transitions are used to attach the piping to the heat exchanger. Diffusers are located at the inlets and outlets of the PVC pipe to reduce the entrance and exit losses at these locations. Butterfly valves located approximately eleven pipe diameters downstream of the heat exchanger can be opened or closed to vary the frictional resistance of the duct system. The butterfly valves located upstream of the heat exchanger are left in the fully open position during testing.

Static pressure is measured at locations approximately three pipe diameters upstream and six pipe diameters downstream of the heat exchanger. The six-pipe-diameter length is sufficient to allow a full pressure recovery downstream of the fans. Pitot-static tubes are used as the static pressure taps. A micromanometer with a sensitivity of 0.051 mm (0.002 in) of water is used to measure pressure.

Airstream flow rate is measured at a location twenty pipe diameters downstream of the butterfly valves. The twenty-diameter length ensures a smooth velocity profile in the air at the measurement location. Eight air velocity measurements are made along both the horizontal and vertical pipe diameters for a total of sixteen velocity measurements in each airstream. Each velocity measurement represents an approximately equal portion of the cross-sectional area of the airstream. The air velocities are measured with pitot-static tubes and a micromanometer with the same sensitivity as that used to measure pressure. The air flow rate is calculated by summing the velocity-area products obtained from the measurements. The pitot tube manufacturer indicates that air flow rate can be measured within two percent using this technique.

Total fan power consumption is measured with a sensitive ac wattmeter with full-scale ranges of 150 and 300 watts and a rated accuracy of 0.5% of full scale.

It should be noted here that the actual "as installed" fan performance may differ from the measured performance depending on the specific mounting arrangement employed by the manufacturer or the installer.

## TESTING PROCEDURE

### Thermal Performance Tests

The following eight test procedures apply to all thermal performance tests. Any exceptions to these procedures are noted under test results for the individual heat exchangers.

1. The volumetric flow rate of the supply airstreams (air supplied to the heat exchanger) are balanced (equalized) within 5%.
2. The pressures of the supply airstreams are set equal to zero (gauge pressure) with-in 0.13 cm (0.05 in) of water.
3. The pressures of the supply airstreams are balanced (equalized) with-in 0.13 mm (0.005 in) water.
4. Test data are recorded only after steady-state conditions are reached. (A rate of temperature change of  $0.42^{\circ}$  ( $0.75^{\circ}\text{F}$ ) per hour or less is considered steady state.) For most tests reported here, the rate of temperature change was less than  $0.28^{\circ}\text{C}$  ( $0.5^{\circ}\text{F}$ ) per hour.
5. All data are recorded manually. Approximately four minutes are required to record test data. Test data are immediately recorded a second time and the two sets of data are compared to eliminate any large errors in instrument reading.
6. Tests are run with six different volumetric flow rates ranging from 85 to  $425\text{ m}^3/\text{hr}$  (50 to  $250\text{ ft}^3/\text{min}$ ).



7. The temperature of the supply airstreams are controlled so that no condensation occurs within the heat exchanger. The actual temperatures required to prevent condensation depend on the room air humidity ratio and the heat exchanger effectiveness. Typical temperatures for the hot and cold supply airstreams are 26.7 °C and 10 °C (80 °F and 50 °F) respectively. (Additional tests have been run under inlet airstream conditions that cause condensation to occur; however, the test results are not described in this report.)
8. For those heat exchangers with internal fan systems, tests are run both with and without the heat exchanger fans operating.

#### Net Cross-Stream Leakage Tests

In testing the net cross-stream leakage of each heat exchanger, the pressures of the supply airstreams are intentionally imbalanced. If the heat exchanger is subject to internal leakage, air will leak from the high-pressure airstream to the low-pressure airstream and the extent of the leakage can be measured with the orifice plate flowmeters. This type of leakage test detects only the net cross-stream leakage. Even when the pressures of the supply airstreams are balanced, there may be air leakage from the high-pressure (upstream) side of the heat exchanger core to the low-pressure (downstream) side. Two equal leaks of this type would counteract each other and thus would not be detected by air flow rate measurements. Cross-leakage tests are run with balance-supply volumetric flow rates of 128 and 254 m<sup>3</sup>/hr (75 and 150 ft<sup>3</sup>/min). The pressure difference of the supply airstreams is varied between 0 and 0.64 cm (0.25 in) of water. The tests are run with room temperature air flowing through both sides of the heat exchanger.

#### Fan Performance Tests

In the fan performance tests, the heat exchanger fans power the flow of ambient (unconditioned) air through the heat exchanger and attached ducting. Butterfly valves located downstream of the fans are opened or

closed until the static pressure produced by each fan is equal, yielding approximately balanced flow rates. Once the static pressure is balanced, the volumetric flow rate of each airstream is measured with a 16-point pitot tube traverse. The total fan power consumption of the heat exchanger fans is read from a sensitive ac wattmeter with the same accuracy as the wattmeter used in the Thermal Performance Test System. The outlet temperature of the airstreams (used for determining air density) is measured with a precision thermometer. The test procedure is repeated for a range of static pressures produced by opening and closing the butterfly valves. (It should be noted that the fan performance tests are actually a test of the fans and the flow resistance of the heat exchanger. The test results will not be the same as those from a classic fan test where fan performance is measured under ideal conditions. Also, the static pressure drop in the piping system is not the same as the "fan static pressure" measured in a classical fan test.)

#### MASS AND ENERGY BALANCE RATIOS FROM TEST DATA

This section describes the mass and energy balance ratios that are calculated from the data for each test.

Mass balance ratios for both air and water, i.e., the ratios of mass flow of air and water out of the heat exchanger to the mass flow into the heat exchanger, are calculated. If no leakage occurred and if measurements were exact, the ratios would have values equal to unity.

An enthalpy balance ratio can be calculated by comparing the total enthalpy of all air leaving the heat exchanger to that entering the heat exchanger. However, enthalpy is not an absolute quantity and is arbitrarily set equal to zero at some reference temperature. The value of the enthalpy balance ratio would change if one chose a different reference temperature. A typical enthalpy balance ratio, based on the tests described in this report, is within 0.005 of unity. It is more meaningful to compare the "unexplained energy gain or loss" of the heat exchanger to the measured rate of heat transfer, as explained below.

If  $Q_{\text{HOT}}$  is the measured rate of energy transfer from the hot airstream and  $Q_{\text{COLD}}$  is the measured rate of energy transfer to the cold airstream, then  $Q_{\text{HOT}}$  minus  $Q_{\text{COLD}}$  is the unexplained energy gain or loss of the heat exchanger. The energy balance ratio is calculated by taking the ratio of the unexplained energy gain or loss to the average of  $Q_{\text{HOT}}$  and  $Q_{\text{COLD}}$ . If there were no leakage of air to and from the heat exchanger, if the heat exchanger were perfectly insulated, and if all measurements were exact, the energy balance ratio would equal zero. A very small air leak or a small error in air flow rate measurement can have a large effect on the energy balance ratio. For instance, if one percent of the hot supply airstream with a temperature of 26.6 °C (80 °F) leaked from the heat exchanger before entering the core, and all measurements were exact, the energy balance ratio for a typical non-condensation test would have a value of 4.4%. If the same amount of air at 21 °C (70 °F) leaked into the heat exchanger, the energy balance ratio would be 3.6%. If the heat exchanger has a low effectiveness, a small leak will have a larger effect on the energy balance ratio.

The range of mass and energy balance ratios calculated from each test series are reported in the discussion of test results for each heat exchanger.

#### METHODS OF PRESENTING TEST RESULTS

In this section of the report, the methods used to present test results are described. The actual test results for each heat exchanger are presented in the report section entitled "Heat Exchanger Descriptions and Test Results."

For each heat exchanger, a plot of effectiveness versus flow rate is given. The effectiveness is based on tests without condensation and without the fans operating. The flow rate value is the average volumetric flow rate of the two airstreams supplied to the heat exchanger. The effectiveness curves are based on tests with balanced volumetric flow rates. For these tests, the capacity ratio was approximately 95 percent with the hot airstream having the smaller capacitance. If the capacity ratio were unity, the effectiveness would be slightly

lower.

If the heat exchanger was tested with its fans operating, plots of "apparent cold airstream effectiveness" versus flow rate are given. The apparent cold airstream effectiveness is the temperature change of the cold airstream divided by the temperature difference between the two airstreams entering the heat exchanger. The word "apparent" is used because the cold airstream did not have the minimum capacitance and, therefore, the cold airstream effectiveness is not a true effectiveness value. Apparent effectiveness values are presented for tests in which the heat exchanger fans were not operating and for tests in which the fans were operating. Also presented are "corrected apparent cold airstream effectiveness values" which are described below.

The expected temperature change of the cold airstream resulting from the addition of fan heat can be calculated if the amount of fan heat added to the airstream is known. This calculated temperature change can be subtracted from the actual temperature change of the cold airstream and the result used to produce a "corrected apparent cold airstream effectiveness." For the two heat exchangers tested with fans, the fans and fan motors were located in the airstreams downstream of the heat exchanger core. Therefore, all of the heat from the cold airstream fan and none of the heat from the hot airstream fan will be added to the cold airstream. The corrected apparent effectiveness values are calculated by assuming that the total fan power consumption immediately becomes heat. Actually, a portion of the fan energy will be converted to potential energy when the fan increases the airstream pressure. This potential energy is eventually converted to heat because of friction between the flowing air and the piping. Because the fans and fan motors are generally inefficient, most of the power consumed by the fans is immediately given off as heat.

A plot of airstream static pressure drop versus flow rate is presented for each heat exchanger except the Genvex Heat Exchanger. The pressure drop is the average decrease in static pressure of the two airstreams flowing through the heat exchanger. The flow rate is the average volumetric flow rate of the two airstreams supplied to the heat

exchanger.

The results of the net cross-stream leakage tests are presented in plots of net cross-stream leakage versus pressure difference. The net cross-stream leakage is defined as the change in volumetric flow rate of an airstream divided by its inlet flow rate. The average of the values for the two airstreams is plotted against the static pressure difference between the two airstreams entering the heat exchanger.

The results of the fan system tests are presented in plots of the static pressure drop in the piping system and fan power consumption versus airstream flow rate. The flow rate is the average flow rate of the two airstreams when the static pressures produced by the fans are balanced. The fan power consumption is the total power consumption for both fans.

#### HEAT EXCHANGER DESCRIPTIONS AND TEST RESULTS

##### VMC Genvex Heat Exchanger - Description

The Genvex Heat Exchanger (Figure 11) has a crossflow core, two fans, and two filters all mounted in an insulated sheet metal case. One side of the case is removable for access to the core, fans, and filters. The core can be easily removed and replaced. The fans are forward-curved centrifugal units with capacitor start-capacitor run fan motors. The 220-volt, single-phase fan motors can be wired for two-speed operation by switching the capacitor in and out of the electrical circuit. When the capacitor is out of the circuit (low fan speed), the fan motor efficiency is reduced. The manufacturer supplies a fan speed control system which was not used for our tests. The motors are designed for use with 50-cycle power typical of European countries but will operate with the 60-cycle power supplied in the United States.

The heat exchanger core is made from parallel plates of aluminum sheet metal. The air passages in the core are formed by the spaces between adjacent sheet metal plates. The sides of these passages are sealed by bending and overlapping the edges of the adjacent plates. In this

design, there is a potential leakage site in the thin crack between the overlapped plate edges. The seals between the heat exchanger core and the case are made from foam-rubber and hard-rubber seals. There are no seals between the core and the metal tracks that support the front and rear edges of the core.

The total heat transfer area in the core is  $8.622 \text{ m}^2$  ( $92.8 \text{ ft}^2$ ). The heat exchanger weighs approximately 68 kg (150 lb). It is manufactured in Denmark. This unit has no known distributor in the United States, and a unit price is not available at this time.

#### VMC Genvex Heat Exchanger - Test Results

Figure 12 shows the effectiveness versus flow rate curve for the Genvex Heat Exchanger. The effectiveness was 64% at  $102 \text{ m}^3/\text{hr}$  ( $60 \text{ ft}^3/\text{min}$ ) and 45.5% at  $391 \text{ m}^3/\text{hr}$  ( $230 \text{ ft}^3/\text{min}$ ). The test results should be considered preliminary because this model exhibited considerable cross-stream leakage.

For these tests, the airstream pressures were set equal to zero at the heat exchanger outlets; therefore the pressure in the heat exchanger was slightly positive in contrast to typical operating conditions in which the pressure would be slightly negative. (The usual test procedure is to set the pressure equal to zero at the heat exchanger inlets, but this procedure caused considerable cross-stream leakage in this heat exchanger.)

The air mass balance ratios for the tests ranged from 0.987 to 1.002 and the water mass balance ratios ranged from 0.962 to 1.11. The energy balance ratios were in the range of  $-0.0163$  to  $-0.196$  and the average energy balance ratio was  $-0.113$ . In general, the test results indicated that air, water, and energy leaked out of the heat exchanger. The mass and energy balance ratios for tests on this heat exchanger had generally much poorer values than those encountered in tests of other heat exchangers. The poor water and energy balance ratios were from the tests with poor air mass balance ratios. Air leakage was evident from around the heat exchanger's removable cover and from several other

locations, and probably accounted in large measure for the poor mass and energy balances.

A plot of airstream static pressure drop versus flow rate is not available for this heat exchanger. The tests were run with the fans removed from the heat exchanger case. The airstream pressure drop for this heat exchanger is increased when the fans are removed; therefore, the data does not accurately represent the true pressure drop characteristics of the heat exchanger.

Figure 13 is a plot of "apparent cold airstream effectiveness" versus flow rate for the Genvex Heat Exchanger. When the fans are operating, the temperature change of the cold airstream is increased by as much as 25 percent at low air flow rates and by a smaller percentage at high flow rates.

The "corrected apparent cold airstream effectiveness" data points are close to the uncorrected data points from tests in which the fans were not operating; therefore, the operation of the fans did not change the rate of heat transfer within the heat exchanger core. It was thought that the operation or lack of operation of the fans would affect the air-flow distribution within the core and, in turn, affect the heat-transfer rate. Since this is not the case, the effectiveness measured without the fans operating is a true measure of the heat-transfer performance of this heat exchanger.

The Genvex Heat Exchanger had the highest amount of net cross-stream leakage of any of the heat exchangers tested.\* Figure 14 contains plots of the net cross-stream leakage versus inlet airstream pressure difference for inlet flow rates of 128 and 255 m<sup>3</sup>/hr (75 and 150 ft<sup>3</sup>/min). When the inlet pressure difference was 6.35 mm of water (0.25 inches of water) and the inlet flow rate was 128 m<sup>3</sup>/hr (75 ft<sup>3</sup>/min), approximately 27% of the air from the high pressure airstream leaked to the low pressure stream. Pressure differences of this magnitude could be

---

\*Net cross-stream leakage test results are presented for this heat exchanger only. For all other heat exchangers, the leakage was too small to be accurately measured with the present system.

encountered in actual use if the duct system for one airstream had a greater flow resistance than that for the other airstream, or if a high wind was directed at an inlet or outlet of the piping system.

The results of the fan performance tests on the Genvex Heat Exchanger are presented in Figure 15 and 16. In the high-fan-speed tests, the air flow rate was varied from 116 to 192 m<sup>3</sup>/hr (68 to 159 ft<sup>3</sup>/min) and the total fan power consumption ranged between 132 and 148 watts. In the low-fan-speed tests, the fan power ranged between 96 and 129 watts as the flow rate was varied between 99 and 196 m<sup>3</sup>/hr (58 and 115 ft<sup>3</sup>/min). The amount of fan power required for a given air flow rate was greater when the low fan speed was used. When the static pressures produced by the fans were balanced, the flow rates of the two airstreams were virtually equal for both the high and low fan speeds.

#### Flakt RDAA Heat Exchanger - Description

The Flakt Heat Exchanger (Figure 17) is a crossflow unit similar in basic design to the Genvex Heat Exchanger. Only the major differences between the two units will be described here.

The air passages in the Flakt Heat Exchanger contain "fins" to increase the heat-transfer and maintain the plate spacing. The fins are thin sheets of aluminum that criss-cross the flow passages and divide the space between the parallel plates into small triangular passages, as shown in Figure 17. There is no bond (adhesive, weld, etc.) between the fins and the parallel plates.

The sides of the parallel-plate air passages are well sealed to prevent air leakage. The seals between the core and the case are made from a soft, pliable rubber material.

This heat exchanger contains an electric resistance heating element to preheat the outside air before it enters the core. The heating element is used to prevent freezing and to insure that the temperature of the air supplied to the residence does not fall below 11 °C (52 °F). The preheating of the outside air should prevent freeze-up in the core;



however, it will reduce the amount of heat recovered from the exhausted airstream.

The total area for heat transfer between airstreams is  $7.80 \text{ m}^2$  ( $84 \text{ ft}^2$ ). The unit weighs approximately 36.3 kg (80 lbs). The heat exchanger is manufactured in Sweden and is available in the United States through Flakt Products, Inc., P.O. Box 21500, Fort Lauderdale, Fla. 33335. The most recent price quotation from the distributor is \$850 per unit.

#### Flakt RDAA Heat Exchanger - Test Results

The effectiveness versus flow rate curve for the Flakt Heat Exchanger is presented in Figure 18. The effectiveness was 67.5 % at  $102 \text{ m}^3/\text{hr}$  ( $60 \text{ ft}^3/\text{min}$ ) and 56 % at  $39 \text{ m}^3/\text{hr}$  ( $230 \text{ ft}^3/\text{hr}$ ).

The air mass balance ratios for the tests ranged between 0.996 and 1.011, the water mass balance ratios ranged between 0.991 and 1.010, and the energy balance ratios ranged between  $-0.024$  and  $+0.088$ . The average energy balance ratio for all the tests was  $.038$ .

Figure 19 is a plot of airstream static pressure drop versus flow rate for this heat exchanger. The pressure drop was 2.5 mm of water at  $102 \text{ m}^3/\text{hr}$  and 25.7 mm of water at  $391 \text{ m}^3/\text{hr}$  (0.1 in of water at  $60 \text{ ft}^3/\text{min}$  and 1.0 in of water at  $230 \text{ ft}^3/\text{min}$ ).

The "apparent cold airstream effectiveness" is plotted versus flow rate in Figure 20 for the Flakt Heat Exchanger. The fan heat increases the temperature change of the cold airstream by as much as 15 percent at low flow rates and by a smaller percentage at higher flow rates. The "corrected apparent cold airstream effectiveness" data points are very close to the uncorrected data points from tests in which the fans were not operating. Therefore, as in the Genvex Heat Exchanger, the operation of the fans does not affect the rate of heat transfer within the core, and the effectiveness measured without the fans operating is a valid measure of heat exchanger performance.

The results of the fan performance tests are presented in Figure 21. In the high-fan-speed tests, the total fan power consumption ranged from 139 to 160 watts as the flow was varied from 105 to 292 m<sup>3</sup>/hr (61 to 172 ft<sup>3</sup>/min). When the static pressures produced by the fans were balanced, the volumetric flow rate of the exhaust air stream (for air that would be exhausted from the residence) was from 4% to 10% greater than the flow rate of the supply airstream.

For the low-fan-speed tests, the rotational speed of the fan was very low and there is an apparent breakdown in fan performance; however, we did not use the fan speed control system that is supplied by the manufacturer. The low-fan-speed test results are not presented because the fans did not perform well in the low-speed mode.

#### Plastic-Sheet Heat Exchanger - Description

The Plastic-Sheet Heat Exchanger (Figure 22) was fabricated at Lawrence Berkeley Laboratory. It is similar to a Canadian model which was specifically designed so that it could be constructed cheaply and easily by a homeowner.

In this heat exchanger, the air flows in a counterflow arrangement throughout most of the core. The core is constructed from parallel sheets of 0.015 cm (0.006 in) thick polyethylene plastic. The plastic sheets are separated by 1.90 cm (0.75 in) thick wood strips that form the exterior frame of the heat exchanger. All junctions between the plastic and the wood strips are sealed with a silicone sealant. The outside of the heat exchanger is covered with 0.318 cm (1/8 in) thick finished plywood. Short sections of sheet metal ducting are attached to the heat exchanger inlets and outlets. The heat exchanger was tested without fans.

This heat exchanger has much larger outer dimensions than the other units tested; its outer dimensions are approximately 200 by 50 by 36 cm (78 by 20 by 14 in). The unit weighs approximately 63.5 kg (140 lbs). The total heat transfer area is 19.3 m<sup>2</sup> (208 ft<sup>2</sup>).

This unit is not available commercially, but a similar Canadian unit is available from D.C. Heat Exchangers, Rural Route 3, Saskatoon, Saskatchewan, Canada for approximately \$425. In the Canadian heat exchanger, the air passages are 1.27 cm (0.5 in) thick; therefore, the heat-transfer area is greater and the effectiveness is expected to be higher. The Canadian unit comes with external fans and sheet metal for attachment to round ductwork. In the most recent model, all connections are made on one side of the heat exchanger so that the unit can be placed in a corner to save space. A set of construction plans are available for \$2 from Division of Extension, University of Saskatchewan, Saskatoon, Canada.

#### Plastic-Sheet Heat Exchanger - Test Results

The Plastic-Sheet Heat Exchanger had the lowest effectiveness of all the units tested. In addition, it was impossible to maintain steady pressures and flow rates during testing. The flexible plastic sheets that form the air passages deform with even a slight imbalance in airstream pressure. (The air channels for the high-pressure airstream expand and those for the low-pressure airstream contract.) Even after very carefully balancing the pressures, the airstream pressures and flow rates fluctuated for no apparent reason. Since slightly more stable conditions were obtained by balancing the airstream pressures at the heat exchanger outlets, this procedure was used for all tests. The pressure in the heat exchanger was slightly positive during testing -- the typical operating condition for this heat exchanger.

Figure 23 is the plot of effectiveness versus flow rate for this heat exchanger. The effectiveness was 56% at 102 m<sup>3</sup>/hr (60 ft<sup>3</sup>/min) and 44% at 391 m<sup>3</sup>/hr (230 ft<sup>3</sup>/min). The air mass balance ratios for the tests ranged between 0.992 and 0.999 and the water mass balance ratios ranged between 0.972 and 0.997. The minimum and maximum energy balance ratios were -.130 and +.032 with an average value of -.053.

The pressure drop versus flow rate curve for the Plastic Sheet Heat Exchanger is presented in Figure 24. The static pressure drop of the airstreams was 0.5 mm of water at 102 m<sup>3</sup>/hr and 15.3 mm of water at 391 m<sup>3</sup>/hr (0.02 in of water at 60 ft<sup>3</sup>/min and 0.6 in of water at 230 ft<sup>3</sup>/min).

#### Aldes VMPI Heat Exchanger - Description

Figure 25 presents a drawing of the Aldes VMPI Heat Exchanger. This heat exchanger has a complicated plastic core. The air flow arrangement is mostly counterflow; however, near the heat exchanger ends, the air flows are perpendicular (crossflow). The flow passages in the counterflow section of the core are diamond-shaped. The diamond-shaped passages for supply air (air supplied to the residence) are separated into two sections by a vertical plastic divider. The plastic air channels are rigid enough to hold their shape even when the airstream pressures are imbalanced. The plastic core is contained in an insulated sheet metal case.

The heat exchanger was tested without fans. It is normally sold as part of a complete system containing the heat exchanger, two fans mounted in small fan boxes, flexible ducting, and diffusers. The manufacturer recommends installing the exhaust air fan upstream of the heat exchanger and the supply air fan downstream in order to assure that the maximum amount of fan heat will be delivered to the residence. The fans are 220 volt and are designed for 50-cycle operation but will run on 60-cycle power.

The total area for heat transfer within the heat exchanger is 19.3 m<sup>2</sup> (208 ft<sup>2</sup>). This unit weighs approximately 22.7 kg (50 lb). The manufacturer installs a complete system in Europe for a total (installed) cost of approximately \$2500. Much of this cost is due to the extensive system of duct work supplied with the heat exchanger.

### Aldes VMPI Heat Exchanger - Test Results

The Aldes Heat Exchanger has a high effectiveness compared to the first three units described. It also has a low airstream pressure drop.

The effectiveness of the Aldes Heat Exchanger, presented in Figure 26, was 74% at 102 m<sup>3</sup>/hr (60 ft<sup>3</sup>/min) and 63% at 391 m<sup>3</sup>/hr (230 ft<sup>3</sup>/min). The air mass balance ratios ranged from 0.998 to 1.008 and the water mass balance ratios ranged from 0.990 to 1.039. The minimum and maximum energy balance ratios were -.049 and +.046 and the average value was -.008.

The airstream static pressure drop versus flow rate curve is presented in Figure 27. The static pressure drop was 1.3 mm of water at 102 m<sup>3</sup>/hr and 10.7 mm of water at 391 m<sup>3</sup>/hr (0.05 in of water at 60 ft<sup>3</sup>/min and 0.42 in of water at 230 ft<sup>3</sup>/min). This is the lowest overall static pressure drop of all the heat exchangers tested to date.

The relatively high effectiveness and low pressure drop of this heat exchanger would make it an attractive unit if it were available at low cost.

### Des Champs Model 74 Heat Exchanger - Description

The final heat exchanger described in this report (Figure 28) is predominately a counterflow unit. The air passages are formed by folding a single sheet of aluminum sheet metal back and forth. The use of a single sheet in place of many distinct parallel plates eliminates many paths for potential air leakage. The air-channel spacing is maintained by rows of indentations and protrusions stamped in the sheet metal at regular intervals. The sheet metal core is mounted in an uninsulated sheetmetal case with provisions for attachment to rectangular ducting. The ends of the sheet metal core are sealed with a refractory cement.

The heat exchanger is supplied with externally mounted fans but the fans were removed before testing. The fans are forward-curved centrifugal units with shaded-pole motors.

The heat exchanger has  $10.7 \text{ m}^2$  ( $115 \text{ ft}^2$ ) of heat-transfer area. It weighs approximately  $31.8 \text{ kg}$  ( $70 \text{ lb}$ ) with the fans installed. The heat exchanger is manufactured in the United States by Des Champs Laboratories, Inc., P. O. Box 348, East Hanover, NJ, 07936. This heat exchanger is currently available from the manufacturer for \$250; however, a firm marketing strategy has not been developed and the price may be subject to change.

#### Des Champs Model 74 Heat Exchanger - Test Results

The Des Champs Model 74 Heat Exchanger has the highest overall effectiveness of all the units described in this report. Its effectiveness is higher than that of the Aldes Heat Exchanger for most of the flow rate range; however, its static-pressure-drop is greater than that of the Aldes.

The effectiveness versus flow rate curve for this heat exchanger is presented in Figure 29. The effectiveness was 73% at  $102 \text{ m}^3/\text{hr}$  ( $60 \text{ ft}^3/\text{min}$ ) and 68% at  $391 \text{ m}^3/\text{hr}$  ( $230 \text{ ft}^3/\text{min}$ ). The air mass balance ratios for the tests ranged between 1.000 and 1.016. The water mass balance ratios ranged from 0.973 to 1.008. The minimum and maximum energy balance ratios for the tests were  $-0.018$  and  $+0.079$  and the average value was  $+0.027$ .

The pressure drop versus flow rate curve for this heat exchanger is presented in Figure 30. The airstream static pressure drop was 2.2 mm of water at  $102 \text{ m}^3/\text{hr}$  and 24.7 mm of water at  $391 \text{ m}^3/\text{hr}$  (0.09 in of water at  $60 \text{ ft}^3/\text{min}$  and 0.97 in of water at  $230 \text{ ft}^3/\text{min}$ ).

The manufacturer of the Des Champs Model 74 Heat Exchanger is now producing a larger heat exchanger that is expected to have a higher effectiveness and a lower pressure drop. We will test this model in the near future.

## CONCLUSIONS

The accuracy of the test results on the five heat exchangers described in this report has been demonstrated by the repeatability of our findings and the good mass and energy balances obtained.

Based on the performance criteria of effectiveness, airstream static pressure drop, and net cross-stream leakage, several acceptable heat exchanger models have been identified. We believe, however, that heat exchangers with performance characteristics superior to those found here can be manufactured for a reasonable cost, and we have identified at least one promising model.

The fan power consumption for a residential heat exchanger can be quite low. For instance, the two heat exchangers tested for fan performance required approximately 150 watts to produce a ventilation rate of 255 m<sup>3</sup>/hr (150 ft<sup>3</sup>/min); however, these heat exchangers were equipped with more efficient fan motors than those typically used in the United States.

In the future, thermal performance tests will be conducted on other heat exchangers. In addition, low-temperature thermal performance tests will be run in order to measure the increased performance when condensation occurs and to identify the conditions under which freezing occurs within the heat exchangers. Fan performance testing will continue for additional heat exchangers. Finally, leakage tests will be performed using a new leakage test system that employs a tracer gas to distinguish between airstreams and to accurately indicate the rate of total cross-stream leakage.

## ACKNOWLEDGEMENTS

This report and the work that supports it was accomplished through the efforts of many. Professors Ralph Seban and Ralph Greif aided in the design of the test facility, and John Shively provided us with a site for the test facility. Lloyd Davis, Frank Vilao, Ron Wong, and Brian Pepper constructed the test facility and provided additional assistance. Pipon Boonchanta, Keith Archer, Dennis Cates, Rakefet Bitton, Ron Haynes, Mohammed Zarringhalam, and Ali Rostami ran the tests and also provided additional assistance. John Rudy has been a valuable consultant throughout this project, and Bob Harvey constructed and calibrated the temperature measurement system. James Koonce assisted in many aspects of this test program. Badia El-Adawy made the drawings in this report and Jeana McCreary typed its various drafts and the final manuscript. Finally, special thanks to our editor, Laurel Cook.



## REFERENCES

1. Roseme, G.D., Berk, J.V., Boegel, M.L., Halsey, H.I., Hollowell, C.D., Rosenfeld, A.H., and Turiel, I., Residential Ventilation with Heat Recovery: Improving Indoor Air Quality and Saving Energy, University of California, Lawrence Berkeley Laboratory Report, LBL-9749, May 1980. Presented at the American Society of Heating, Refrigerating and Air Conditioning Engineers/DOE Conference on the Thermal Performance of the Exterior Envelopes of Buildings, Orlando, FL, December 3-5, 1979.
2. Besant, R.W., Dumont, R.S., and Schoenau, G., "Saskatchewan House: 100 Percent Solar in a Severe Climate," Solar Age, 4 (5):18-21, May 1979.
3. Grimsrud, D.T., and Diamond, R.C., Building Energy Performance Standards: Infiltration Issues, University of California, Lawrence Berkeley Laboratory Report, LBL-9623, January 1979.
4. Liebl, J., Talbott, D., and Johnson, R., Feasibility Study for Using Mechanical Ventilation Systems with Air-To-Air Heat Exchangers to Maintain Satisfactory Air Quality Without Losing the Energy Efficiency of a Tightly Constructed House, NAHB Research Foundation, Inc., August 20, 1979 through April 30, 1980.
5. Hollowell, C.D., Berk, J.V., and Traynor, G.W., Impact of Reduced Infiltration and Ventilation on Indoor Air Quality in Residential Buildings, University of California, Lawrence Berkeley Laboratory Report, LBL-8470, November 1979. Also published in ASHRAE Journal, 21 (7):49-53, July 1979.
6. American Society of Heating, Refrigerating, and Air-Conditioning Engineers (ASHRAE), ASHRAE Handbook, Fundamentals, 1977.
7. The American Society of Mechanical Engineers (ASME), Fluid Meters, Their Theory and Application. 1971.

8. The American Society of Heating, Refrigerating, and Air-Conditioning Engineers (ASHRAE), ASHRAE Standard, Standard Measurements Guide: Section on Temperature Measurements, 1974.
9. Davis, J.C., Faison, T.K., Achenbach, P.R., "Errors in Temperature Measurement of Moving Air under Isothermal Conditions using Thermocouples, Thermistors, and Thermometers," ASHRAE Transactions 73, 1967.

TABLE 1. ERRORS IN HUMIDITY MEASUREMENT IF THE DRY BULB TEMPERATURE MEASUREMENT IS 0.19°C (0.35°F) HIGH AND THE WET BULB TEMPERATURE MEASUREMENT IS 0.19°C (0.35°F) LOW.

ACTUAL DRY BULB TEMP. °C(°F)	ACTUAL WET BULB TEMP. °C(°F)	ACTUAL HUMIDITY RATIO	ACTUAL RELATIVE HUMIDITY	MEASURED HUMIDITY RATIO	MEASURED RELATIVE HUMIDITY	% ERROR IN HUMIDITY RATIO	ACTUAL MINUS MEASURED REL. HUMIDITY
37.78 (100)	23.89 (75)	0.01297	0.300	0.01260	0.288	2.9	0.012
37.78 (100)	36.11 (97)	0.03846	0.890	0.03785	0.866	1.6	0.024
21.11 (70)	11.66 (53)	0.00470	0.297	0.00443	0.277	5.7	0.020
21.11 (70)	20.00 (68)	0.01428	0.903	0.01394	0.870	2.4	0.033
4.44 (40)	-0.56 (31)	0.00160	0.308	0.00139	0.263	13.1	0.044
4.44 (40)	3.89 (39)	0.00479	0.918	0.00456	0.863	4.8	0.055

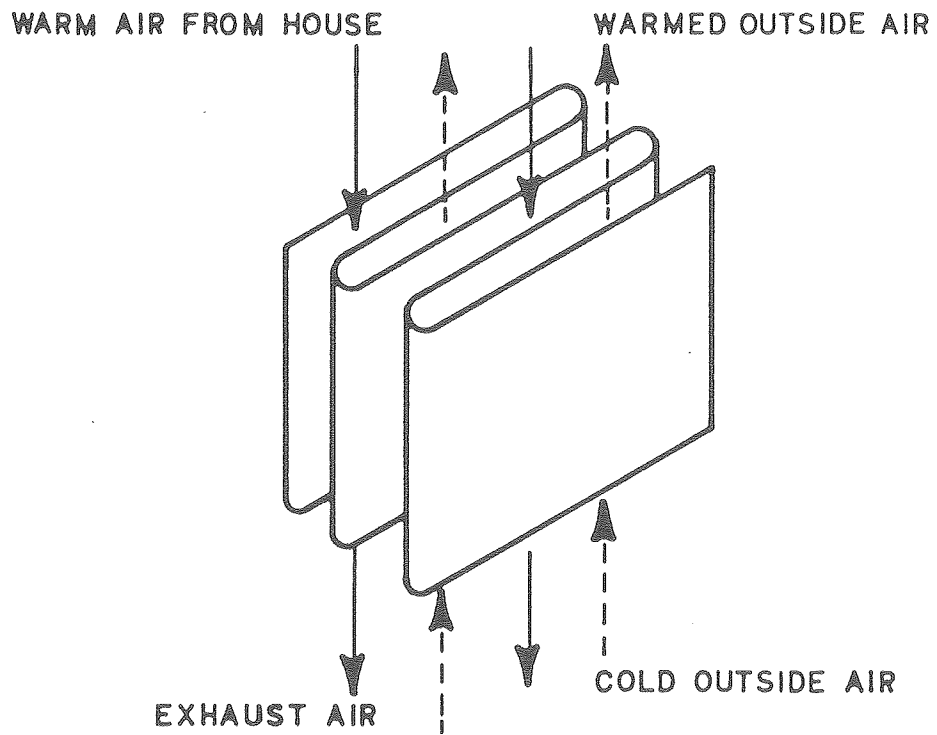

XBL 809-11957

FIGURE 1. SCHEMATIC DIAGRAM OF A COUNTERFLOW HEAT EXCHANGER.

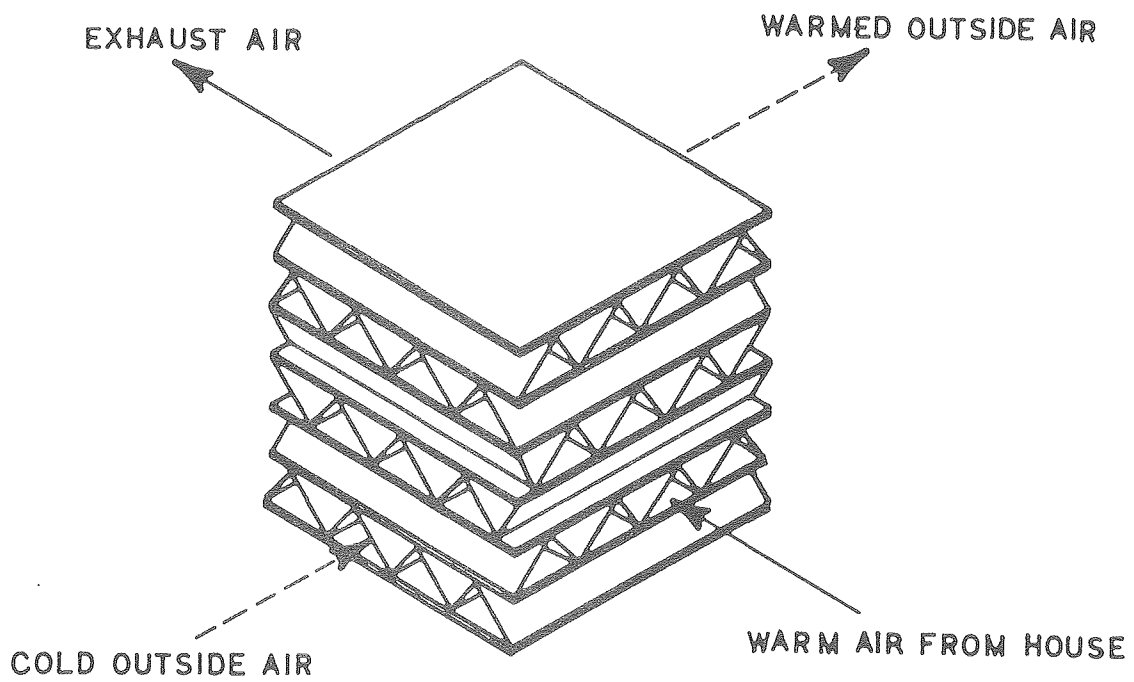

XBL 809-11956

FIGURE 2. SCHEMATIC DIAGRAM OF A CROSSFLOW HEAT EXCHANGER.

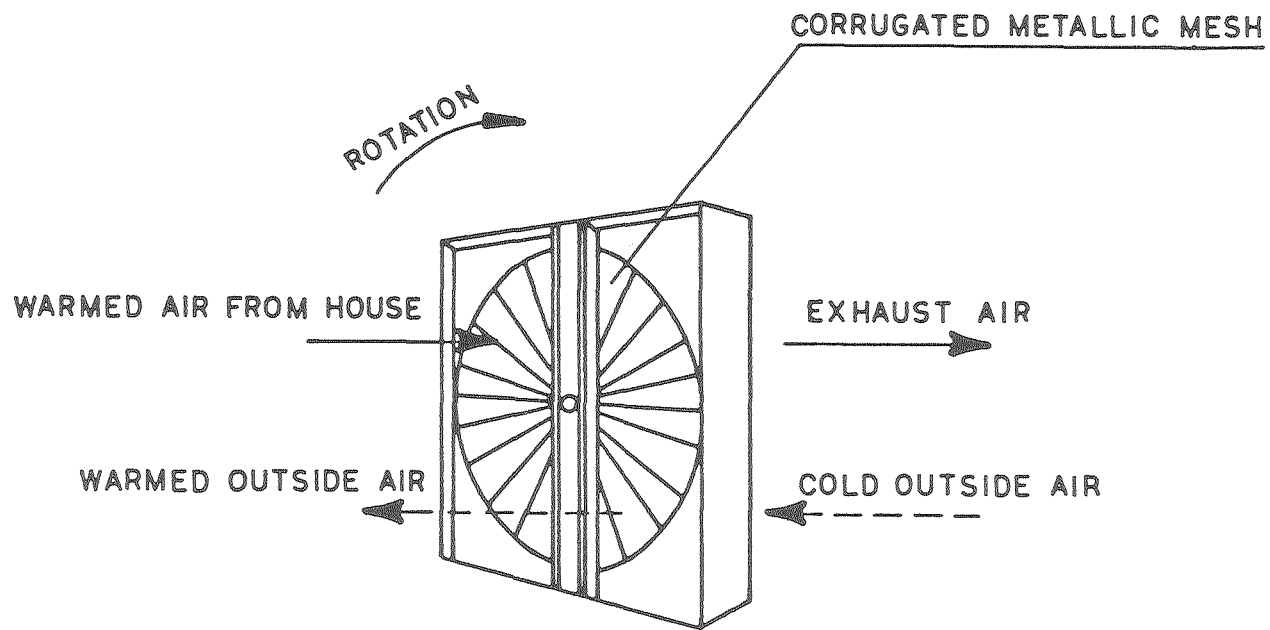

FIGURE 3. SCHEMATIC DIAGRAM OF A HEAT WHEEL HEAT EXCHANGER.

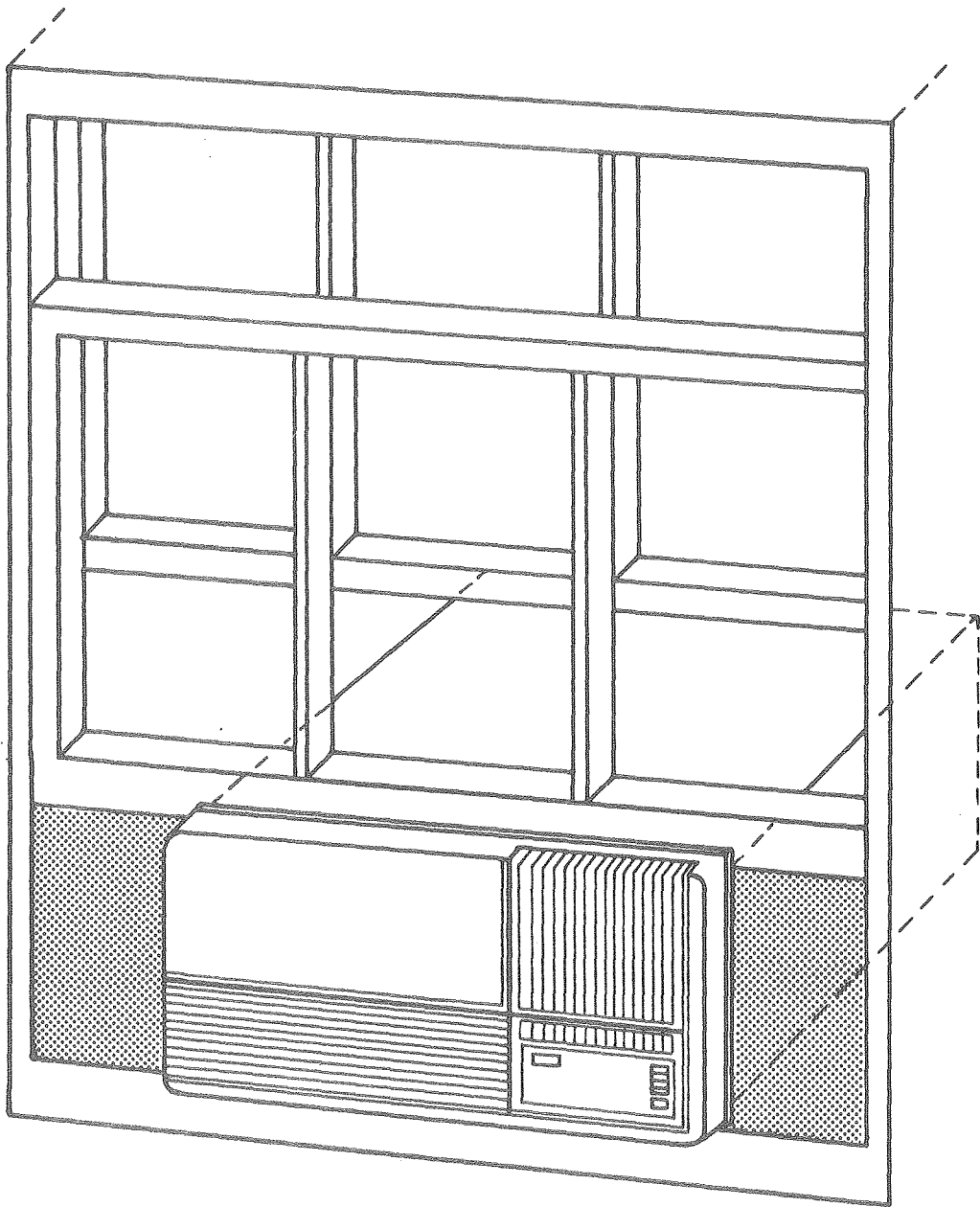

FIGURE 4. WINDOW INSTALLATION OF  
HEAT EXCHANGER

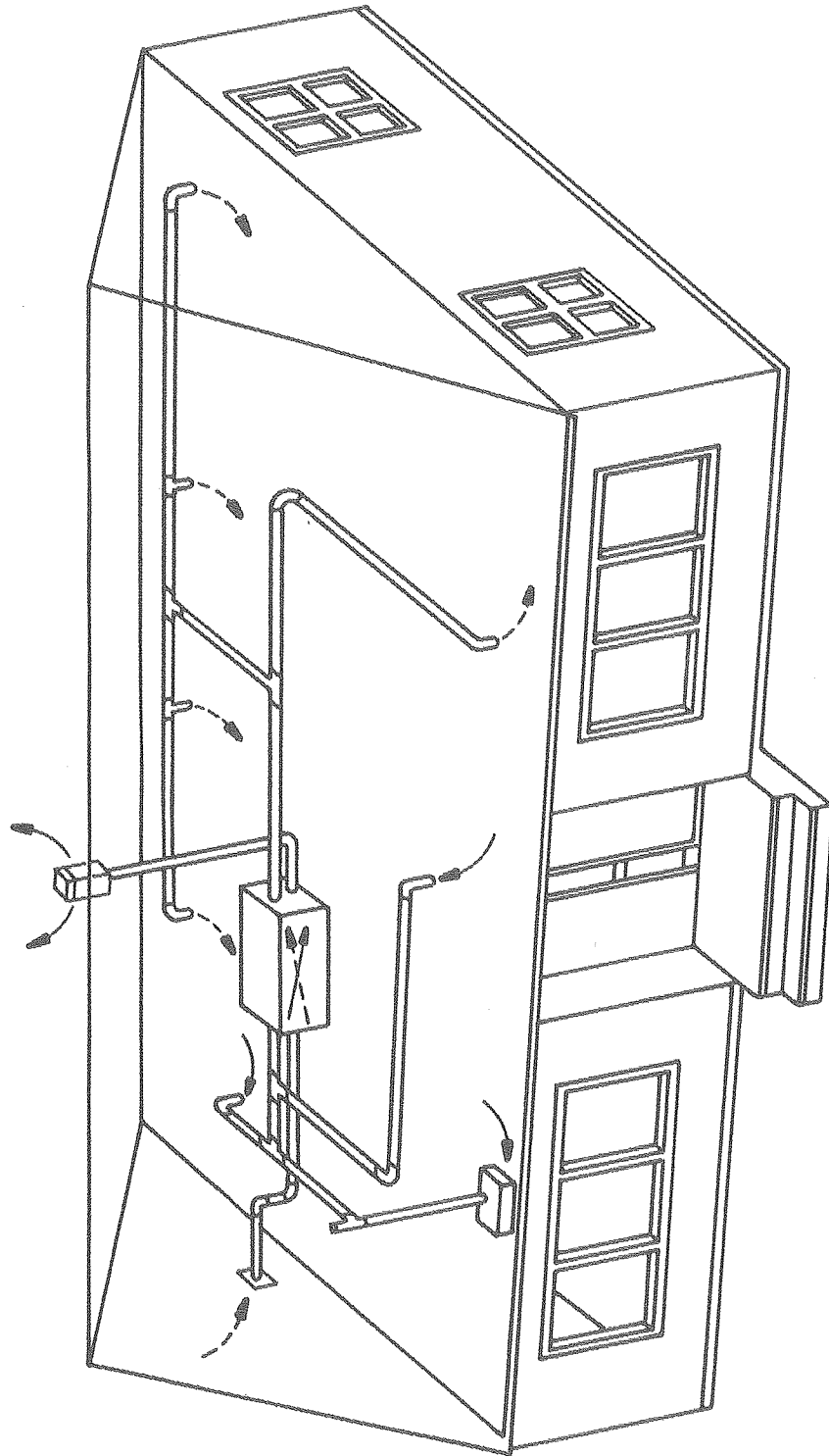
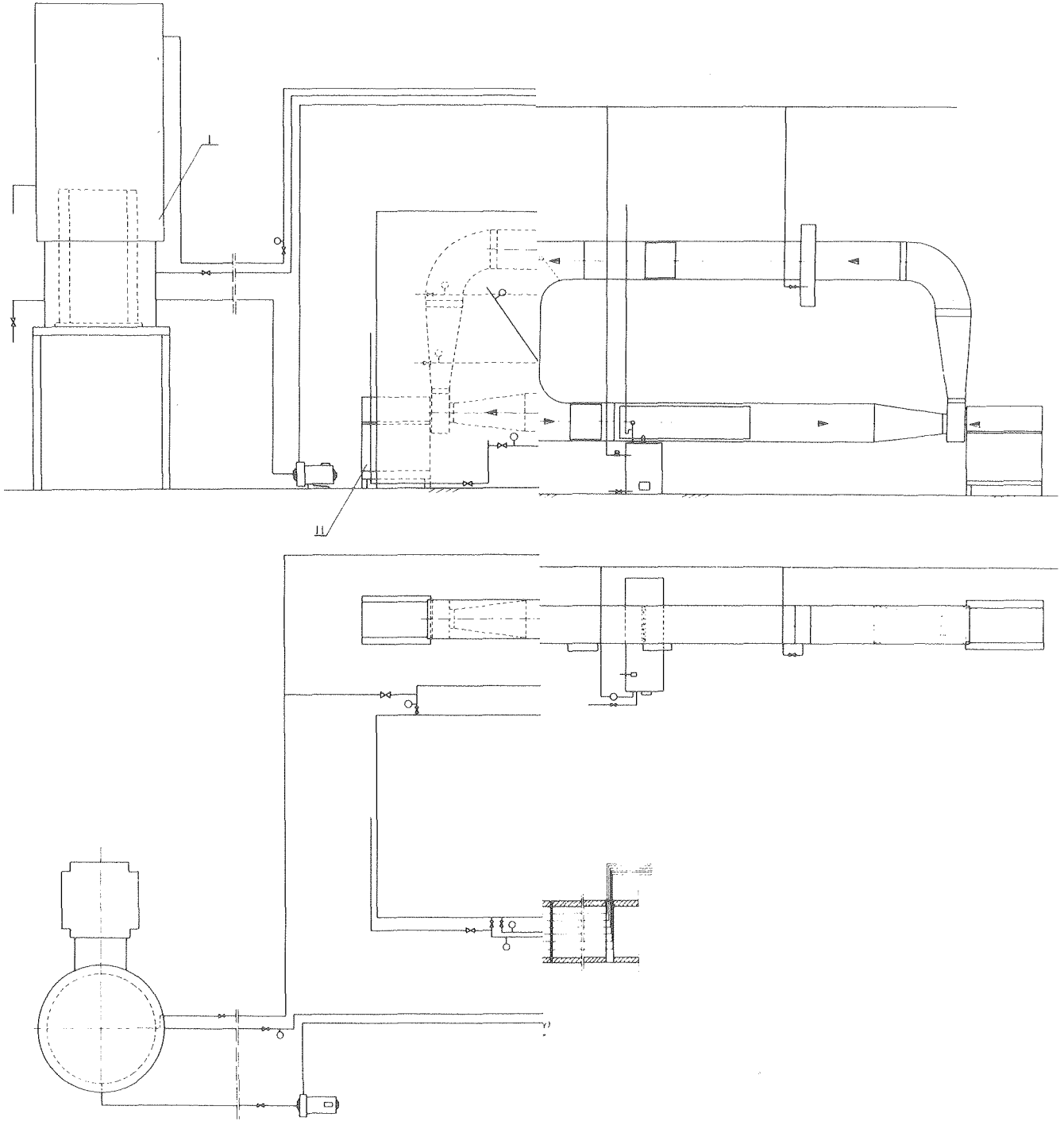

FIGURE 5. FULLY DUCTED INSTALLATION OF HEAT EXCHANGER









IDENTIFICATION OF COMPONENTS FOR FIGURE 6

1. Cooling Tower
2. Duct, Sheetmetal 30.48 cm square
3. Butterfly Valve
4. Reducer -- 15.24 cm to 7.62 cm P.V.C.
5. Orifice Plate Flow Meter, with Aluminum Flanges
6. Pressure Tap
7. Heat Exchanger
8. Transition, Sheetmetal 30.48 cm square to 15.24 cm round
9. Orifice Plate Flow Meter, with PVC Flanges
10. Pump
11. Blower, High Pressure with 1 HP Motor.
12. Storage Tank, 3.64 m<sup>3</sup> (800 gal) -- Ethylene Glycol -- Water
13. Chiller, for Ethylene Glycol-Water, 8790 Watts at -17.8°C
14. Thermometer, Precision, 0.1°C Subdivision, Dry Bulb
15. Thermocouple, 30 gauge, Copper-Constantan, Dry Bulb
16. Thermometer, Precision, 0.1°C Subdivisions, Wet Bulb
17. Thermocouple, 30 gauge, Copper-Constantan, Wet Bulb
18. Pitot Tube
19. Inclined Manometer

20. Mixer, Air Flow

21. Thermocouples, 20 gauge, Copper-Constantan

22. Pressure Tap

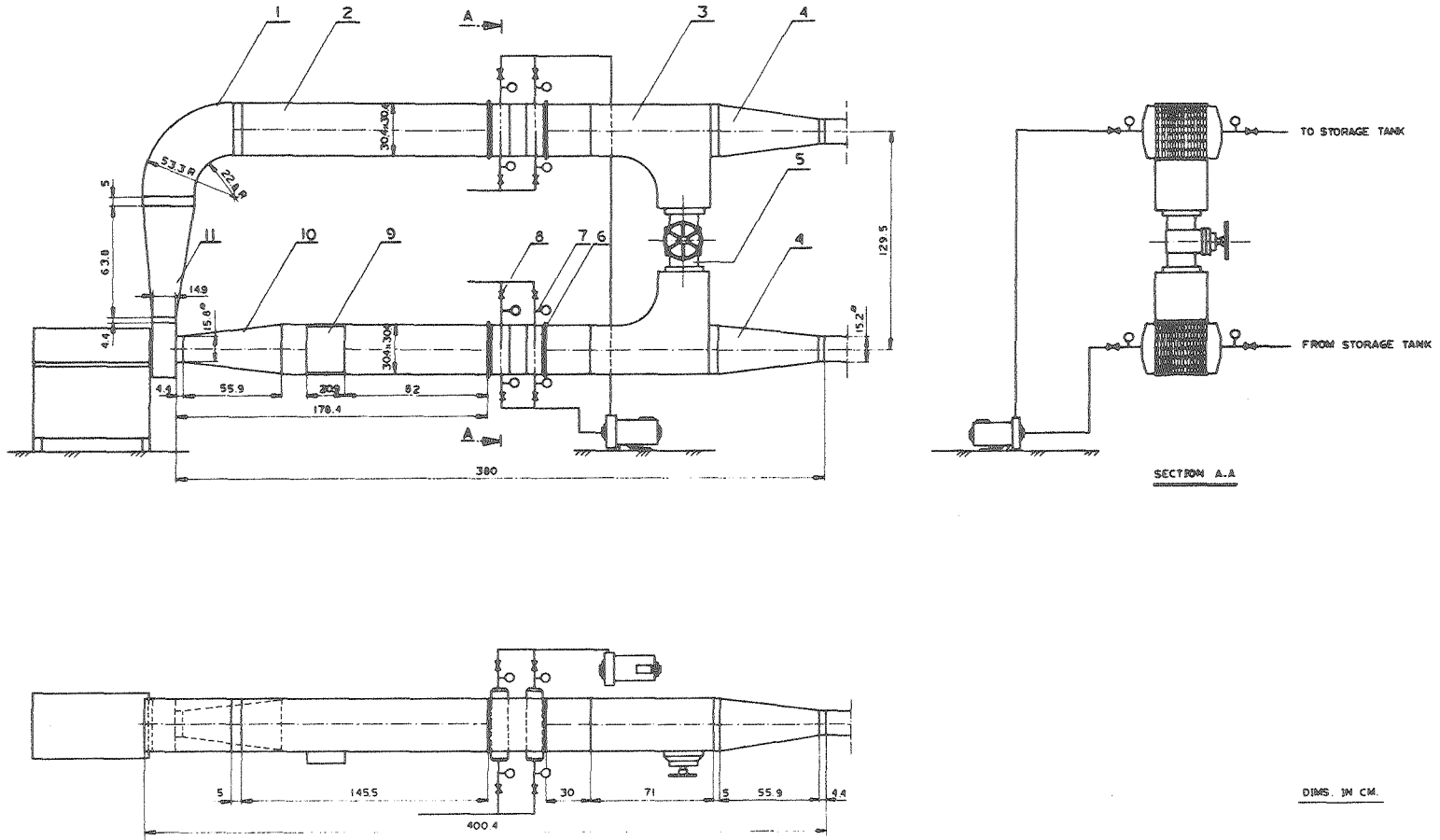

FIGURE 7. COLD-SIDE FLOW LOOP OF THERMAL PERFORMANCE TEST SYSTEM, HEAT EXCHANGER TEST FACILITY

XBL 808-11484

IDENTIFICATION OF COMPONENTS - FIGURE 7

1. Elbow, Sheetmetal, 30.48 cm square
2. Duct, Sheetmetal, 30.48 cm x 30.48 cm
3. Splitter, Sheetmetal, 30.48 cm square to 30.48 cm square to 30.48 cm square
4. Transition, Sheetmetal, 30.48 cm square to 15.24 cm round
5. Valve, Gate, 10.16 cm, PVC
6. Coil, Cooling
7. Gauge, Pressure
8. Valve, Gate, 5.08 cm, PVC
9. Heater, Electric, 2 kW Max.
10. Transition, Sheetmetal, 30.48 cm square to 15.8 cm round
11. Transition, Sheetmetal, 14.9 cm round to 30.48 cm square

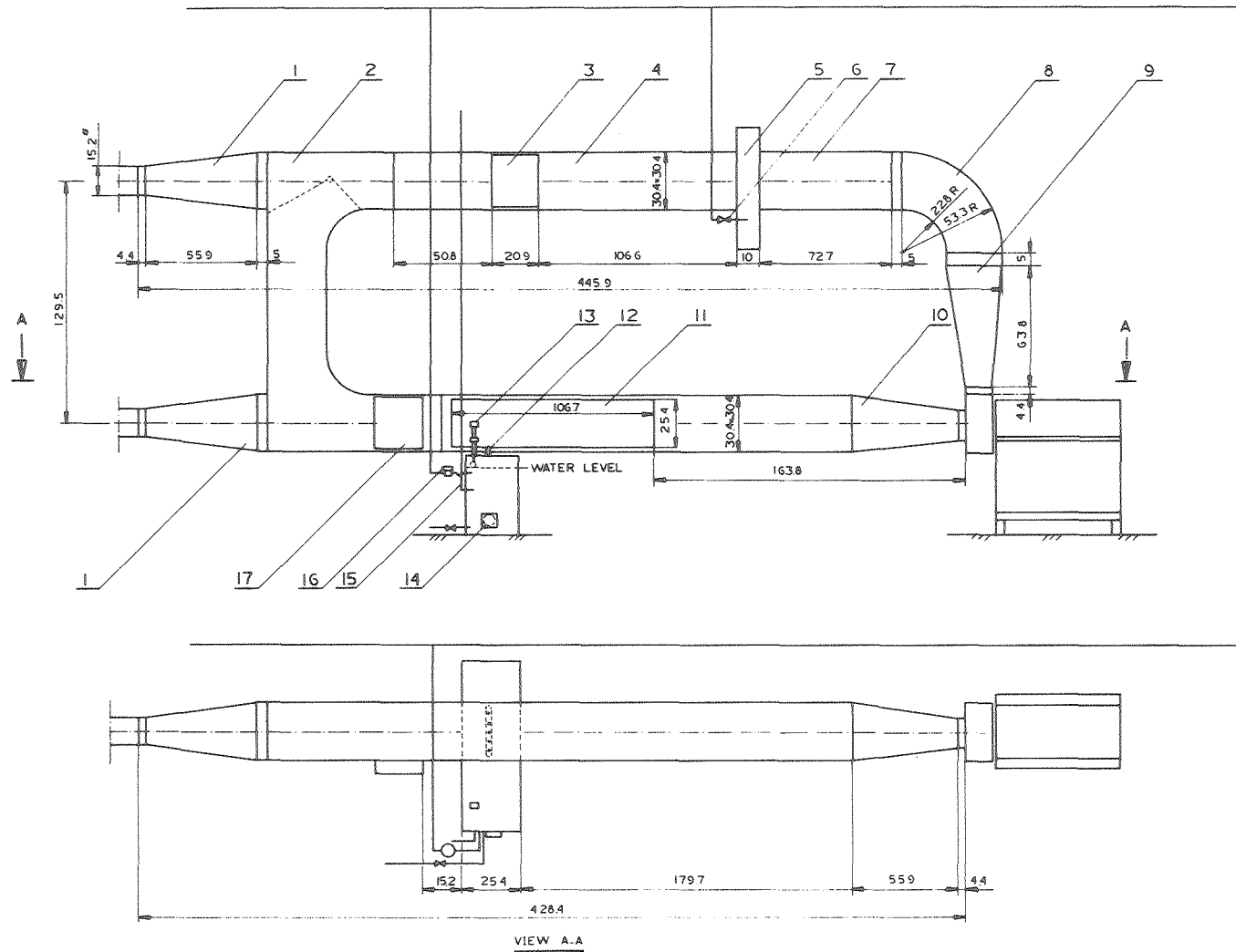

FIGURE 8. HOT-SIDE FLOW LOOP OF THERMAL PERFORMANCE TEST SYSTEM,  
HEAT EXCHANGER TEST FACILITY

DIMS IN CM



IDENTIFICATION OF COMPONENTS FOR FIGURE 8

1. Transition, Sheetmetal, 30.48 cm square to 15.24 cm round
2. Splitter, Sheetmetal, 30.48 cm square to 30.48 cm square to 30.48 cm square
3. Heater, Electric, 2 kW Max
4. Duct, Sheetmetal, 30.48 cm square
5. Humidifier, Drip Type
6. Valve, Shutoff
7. Duct, Sheetmetal, 30.48 cm square
8. Elbow, Sheetmetal, 30.48 cm square
9. Transition, Sheetmetal, 30.48 cm square to 15.24 cm round
10. Transition, Sheetmetal, 15.8 cm round to 30.48 cm square
11. Window, Acrylic Plastic
12. Injector, Steam
13. Valve, Water Level Control, Float Actuated
14. Heating Element, 13 kW Max
15. Pressure Relief Line
16. Valve, Shutoff
17. Heater, Electric, 8 kW Max

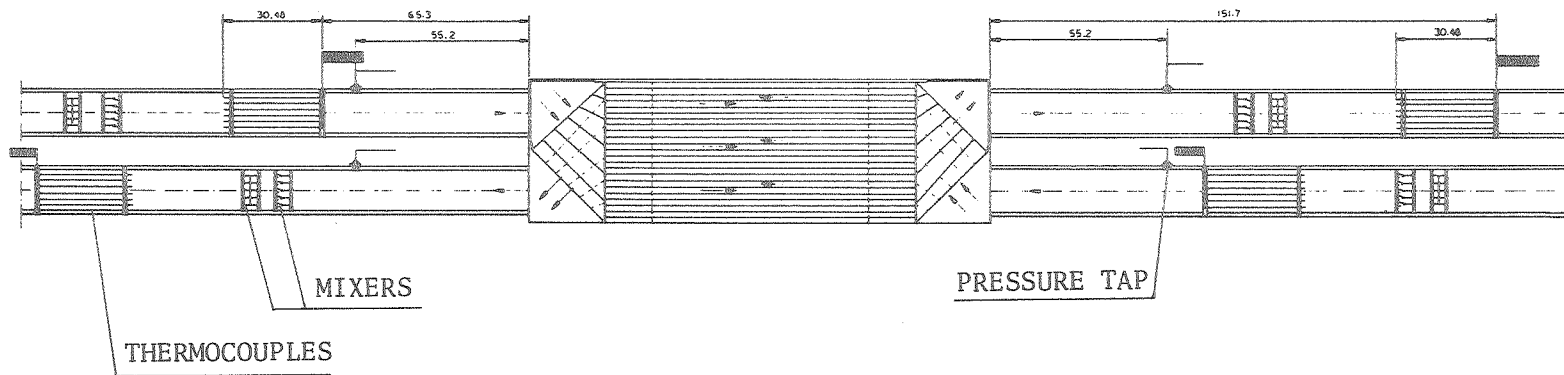
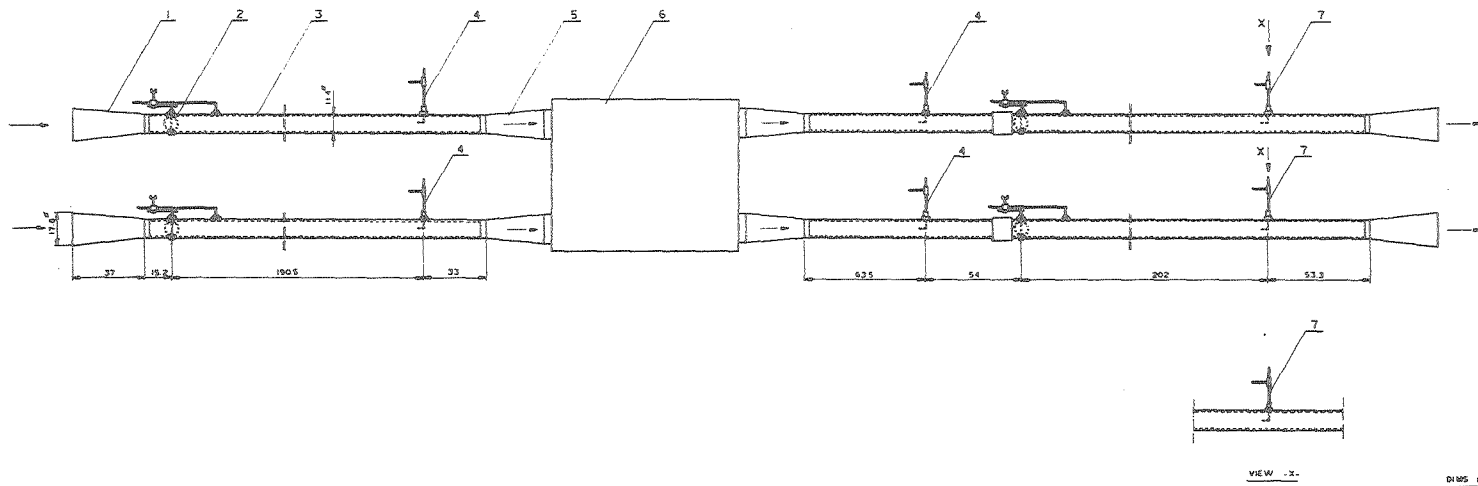

FIGURE 9. LOCATION OF MIXERS, THERMOCOUPLES AND PRESSURE TAPS FOR TYPICAL HEAT EXCHANGER INSTALLATION



D195 IH CL

XBL 809-11736

FIGURE 10. FAN PERFORMANCE TEST SYSTEM, HEAT EXCHANGER TEST FACILITY

IDENTIFICATION OF COMPONENTS FOR FIGURE 10

1. Diffuser, Sheetmetal, 17.8 cm round to 10.16 cm round
2. Valve, Butterfly
3. Pipe, 10.16 cm dia., PVC
4. Static Pressure Tap, Pitot Tube
5. Transition, Sheetmetal
6. Heat Exchanger with Fans
7. Pitot Tube

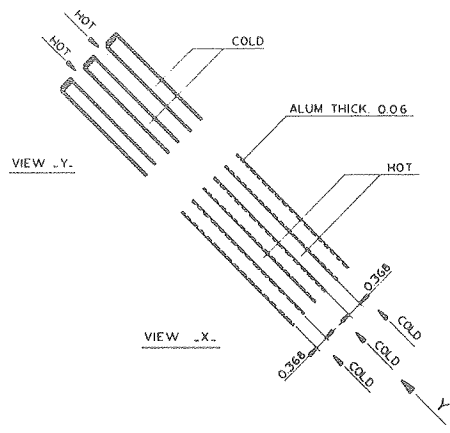
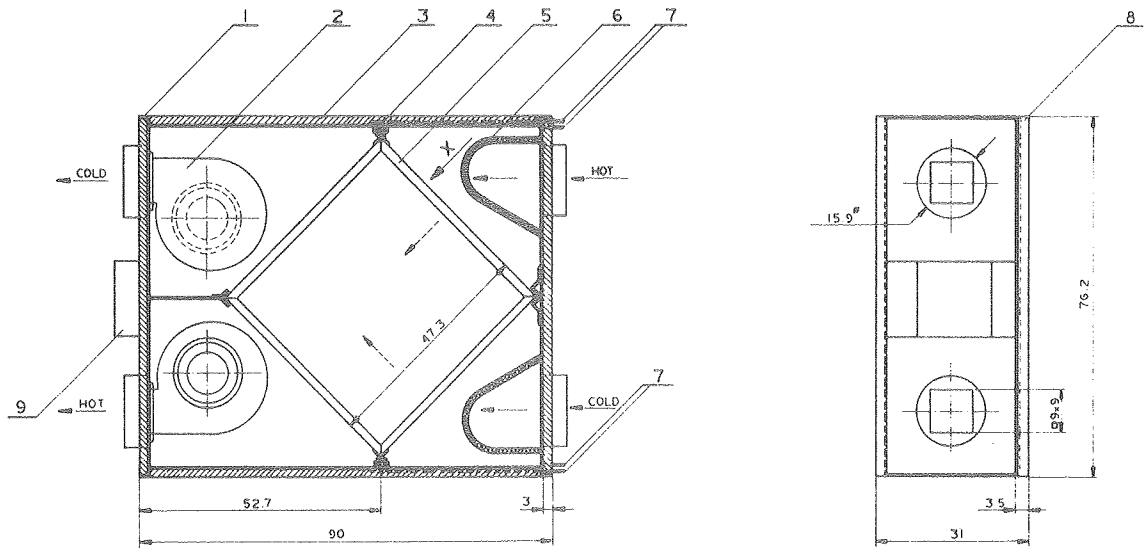

DIMS. IN CM.

XBL 809-11726

PATENTED PRODUCT

FIGURE 11. VMC GENVEX HEAT EXCHANGER

IDENTIFICATION OF COMPONENTS FOR FIGURE 11

1. Mainframe of Case
2. Fan and Motor
3. Insulation
4. Seal, Rubber
5. Core
6. Filter
7. Drain, Condensate
8. Cover, Removable
9. Box, Electrical

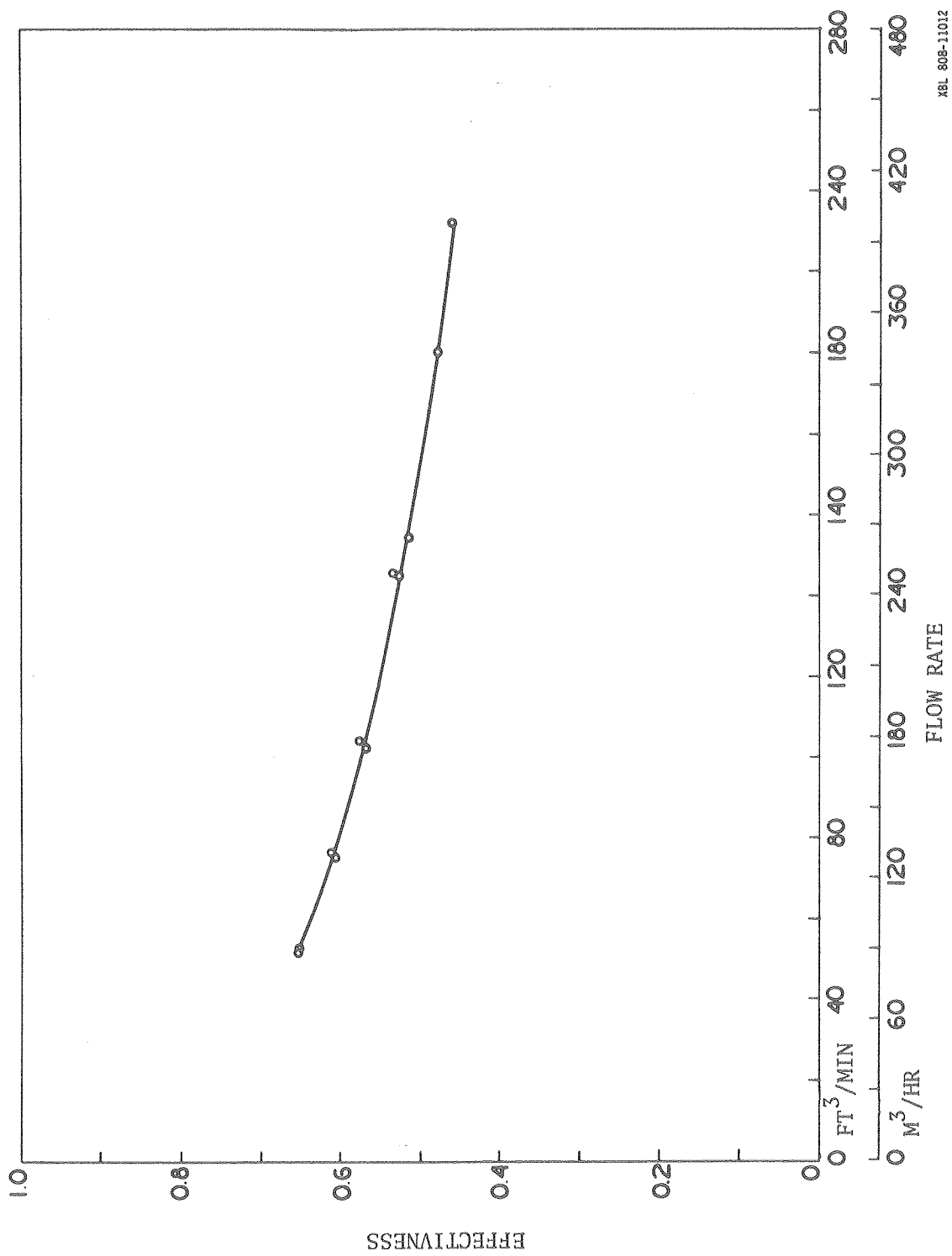

XBL 808-11012

FIGURE 12. EFFECTIVENESS VERSUS FLOW RATE FOR THE VMC GENVEX HEAT EXCHANGER

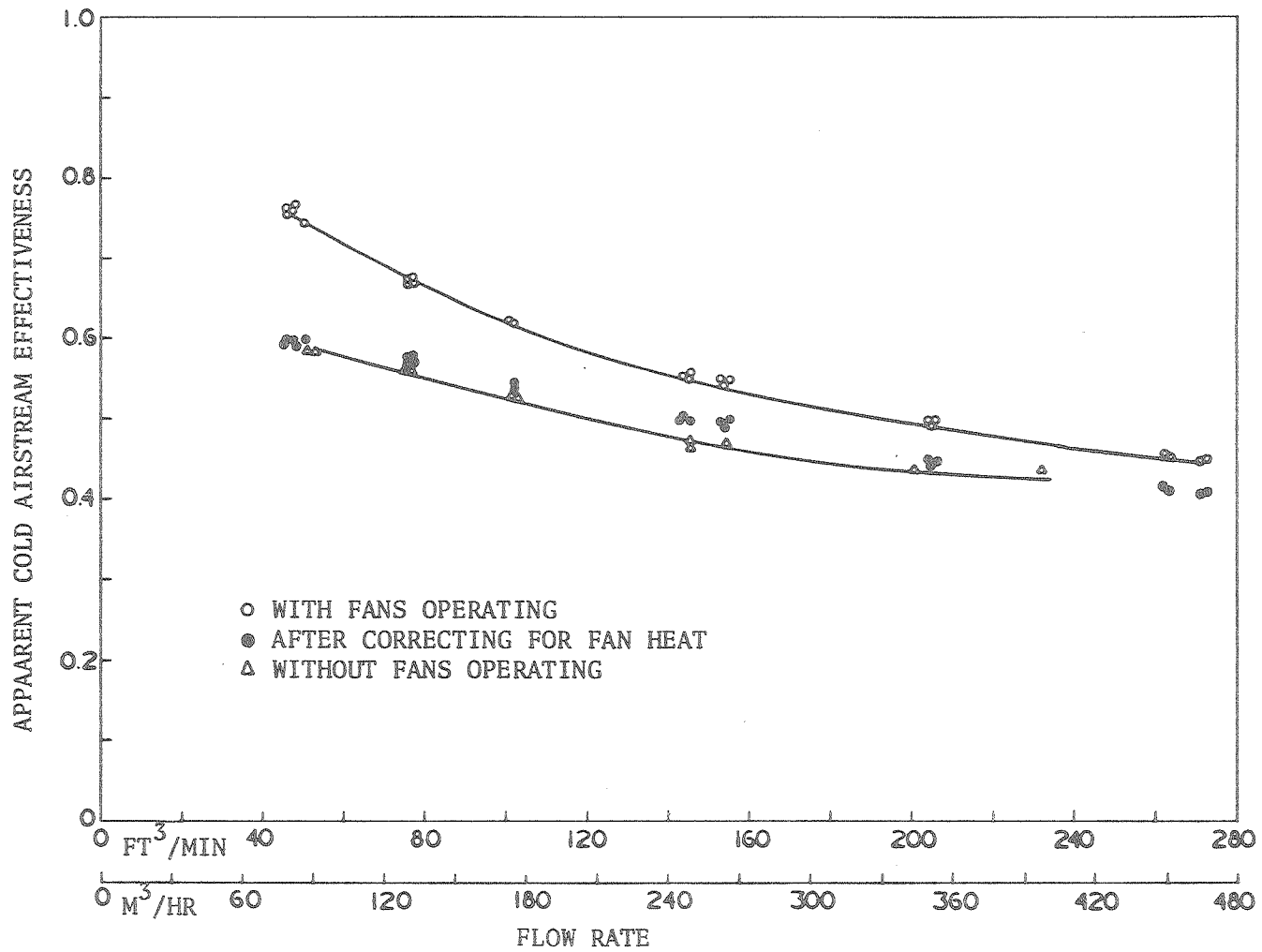

FIGURE 13. APPARENT COLD AIRSTREAM EFFECTIVENESS FOR THE VMC GENVEX HEAT EXCHANGER

XBL 809-11728



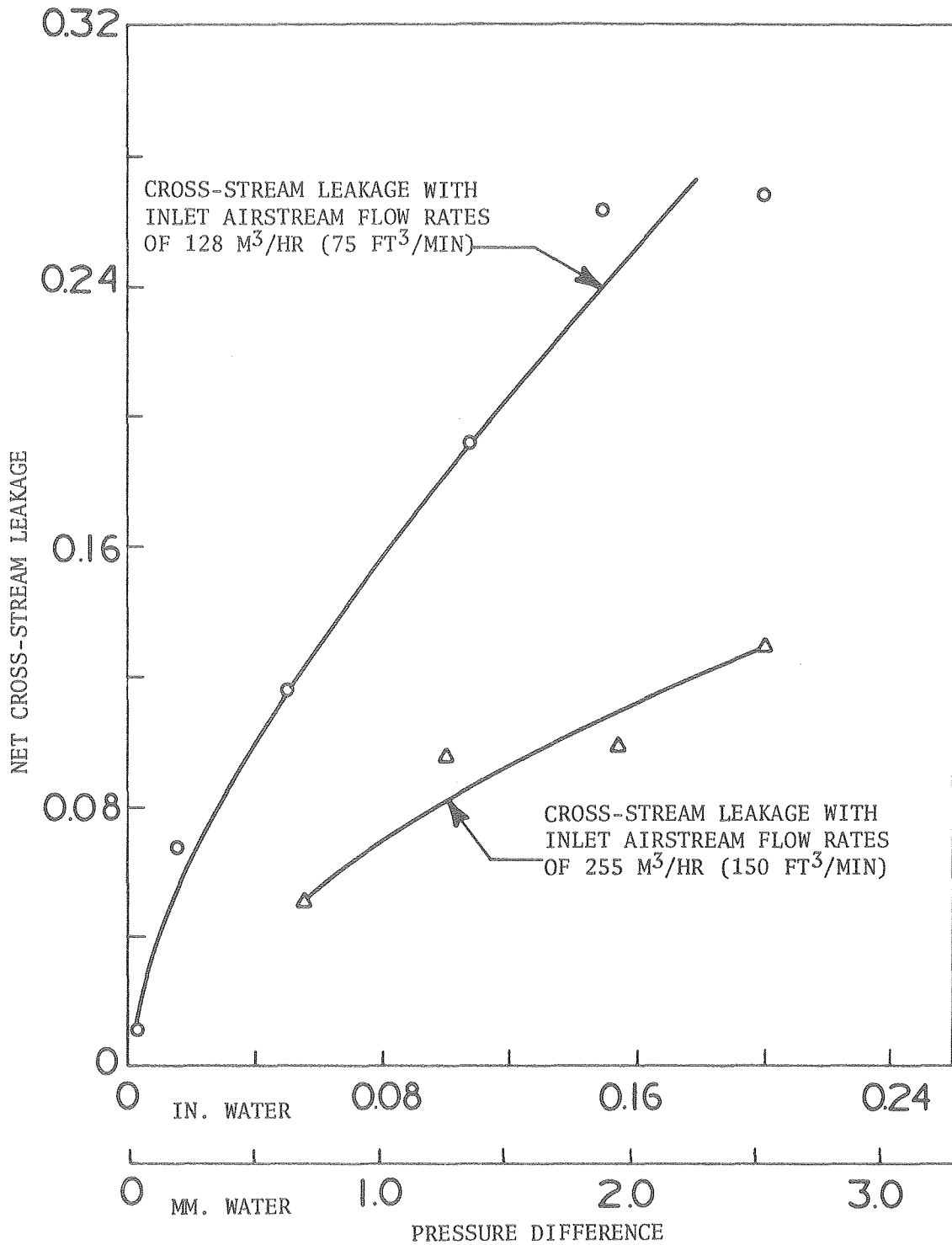

FIGURE 14. NET CROSS-STREAM LEAKAGE VERSUS PRESSURE DIFFERENCE FOR THE GENVEX HEAT EXCHANGER

XBL 809-11735

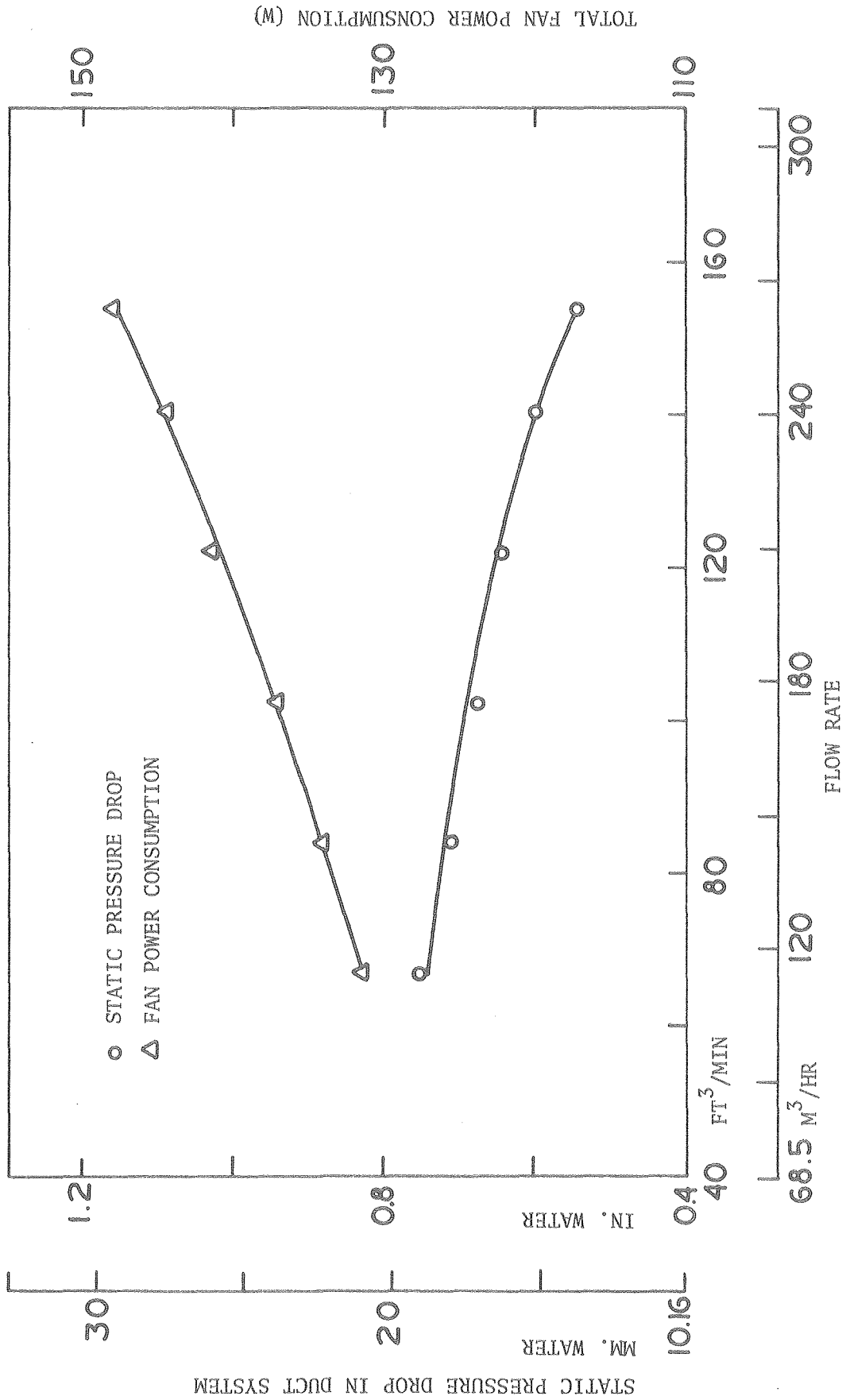

FIGURE 15. STATIC PRESSURE DROP IN DUCT SYSTEM AND TOTAL FAN POWER CONSUMPTION VERSUS FLOW RATE FOR THE VMC GENVEX HEAT EXCHANGER-HIGH FAN SPEED

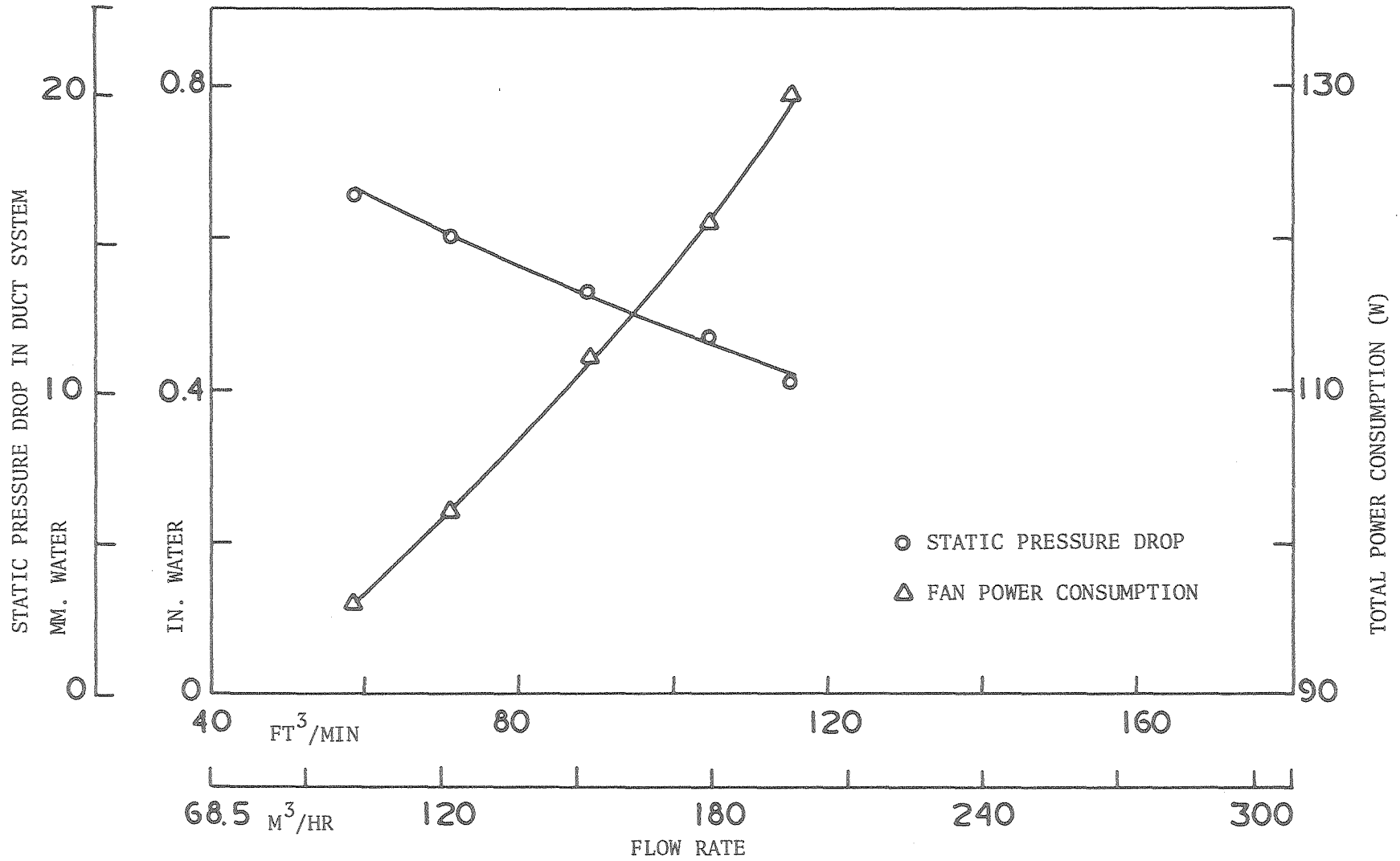
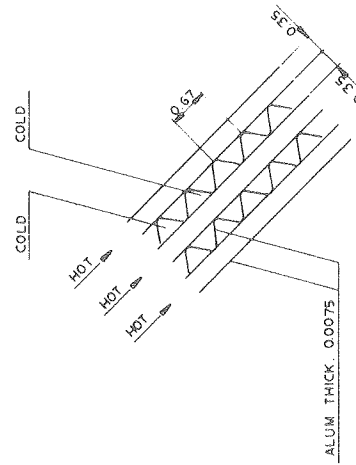
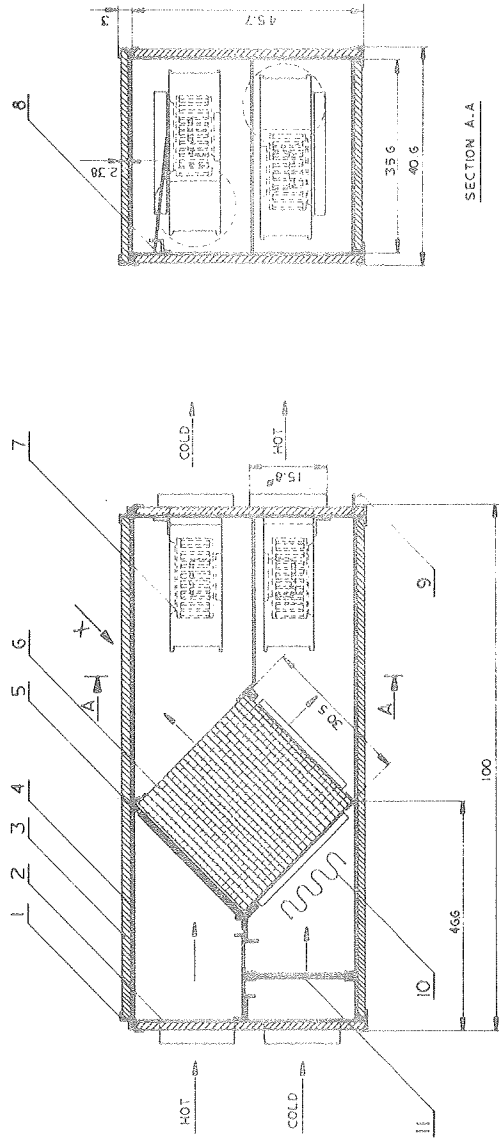

FIGURE 16. STATIC PRESSURE DROP IN DUCT SYSTEM AND TOTAL FAN POWER CONSUMPTION VERSUS FLOW RATE FOR THE VMC GENVEX HEAT EXCHANGER-LOW FAN SPEED



DIMS. IN CM

PATENTED PRODUCT

XBL 809-11480

FIGURE 17. FLAKT RDAA HEAT EXCHANGER

IDENTIFICATION OF COMPONENTS FOR FIGURE 17

1. Cover, Removable
2. Mainframe of Case
3. Insulation
4. Gasket, Rubber
5. Filter
6. Core
7. Fan and Motor
8. Sensor, Temperature
9. Drain, Condensate
10. Heating Element
11. Filter

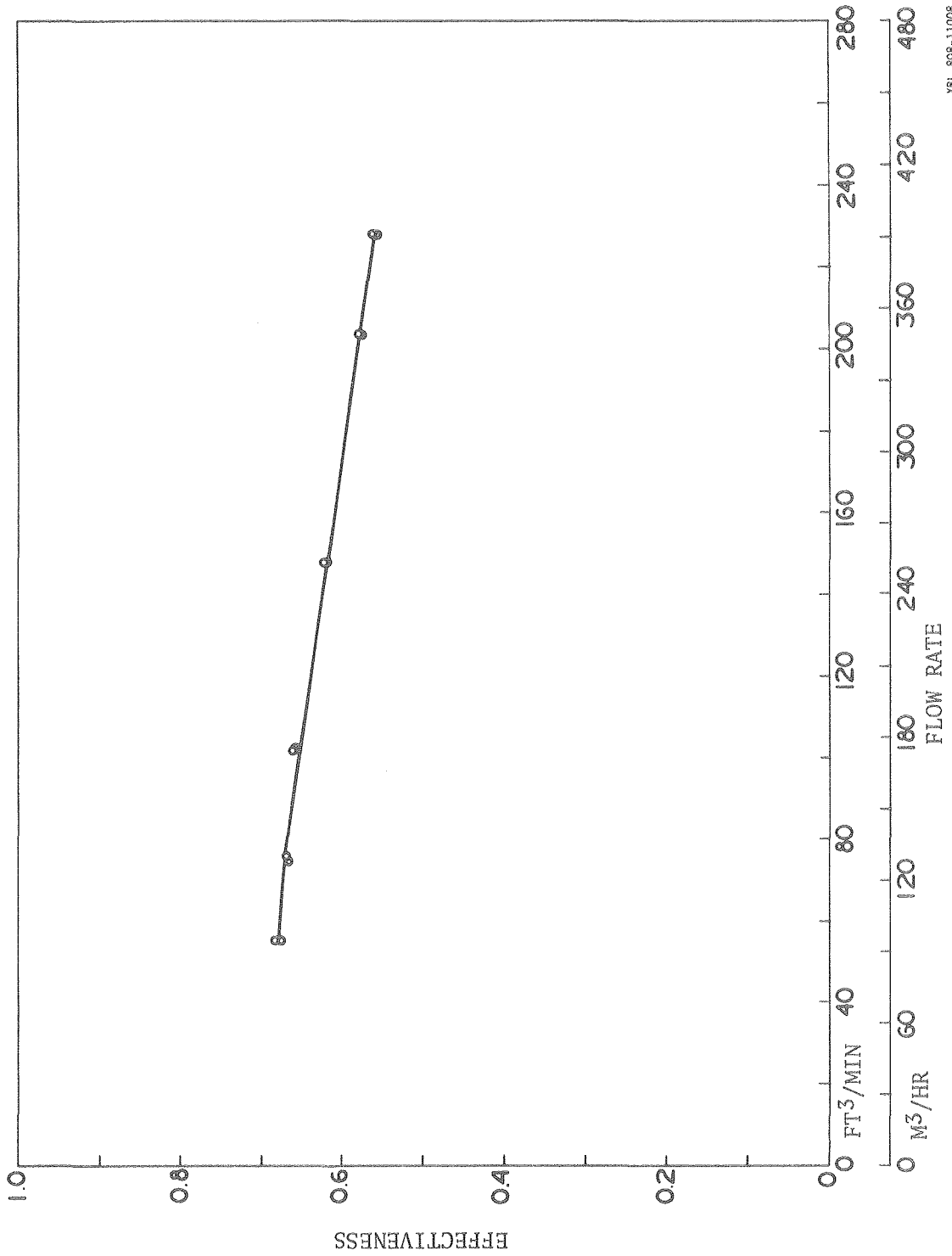

XBL 808-11008

FIGURE 18. EFFECTIVENESS VERSUS FLOW RATE FOR THE FLAKT RDA HEAT EXCHANGER

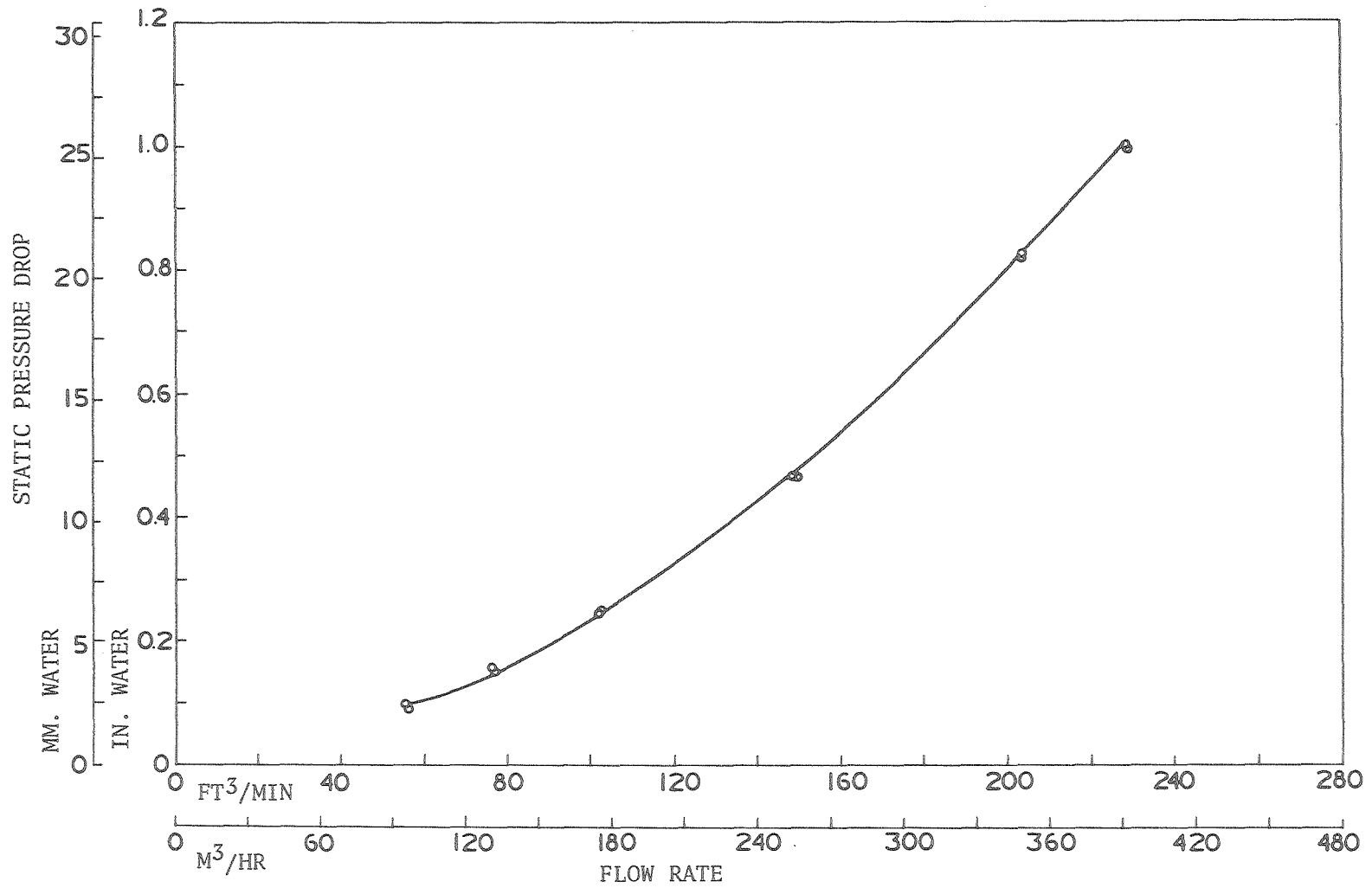

FIGURE 19. STATIC PRESSURE DROP VERSUS FLOW RATE FOR THE FLAKT RDAA HEAT EXCHANGER XBL 809-11742

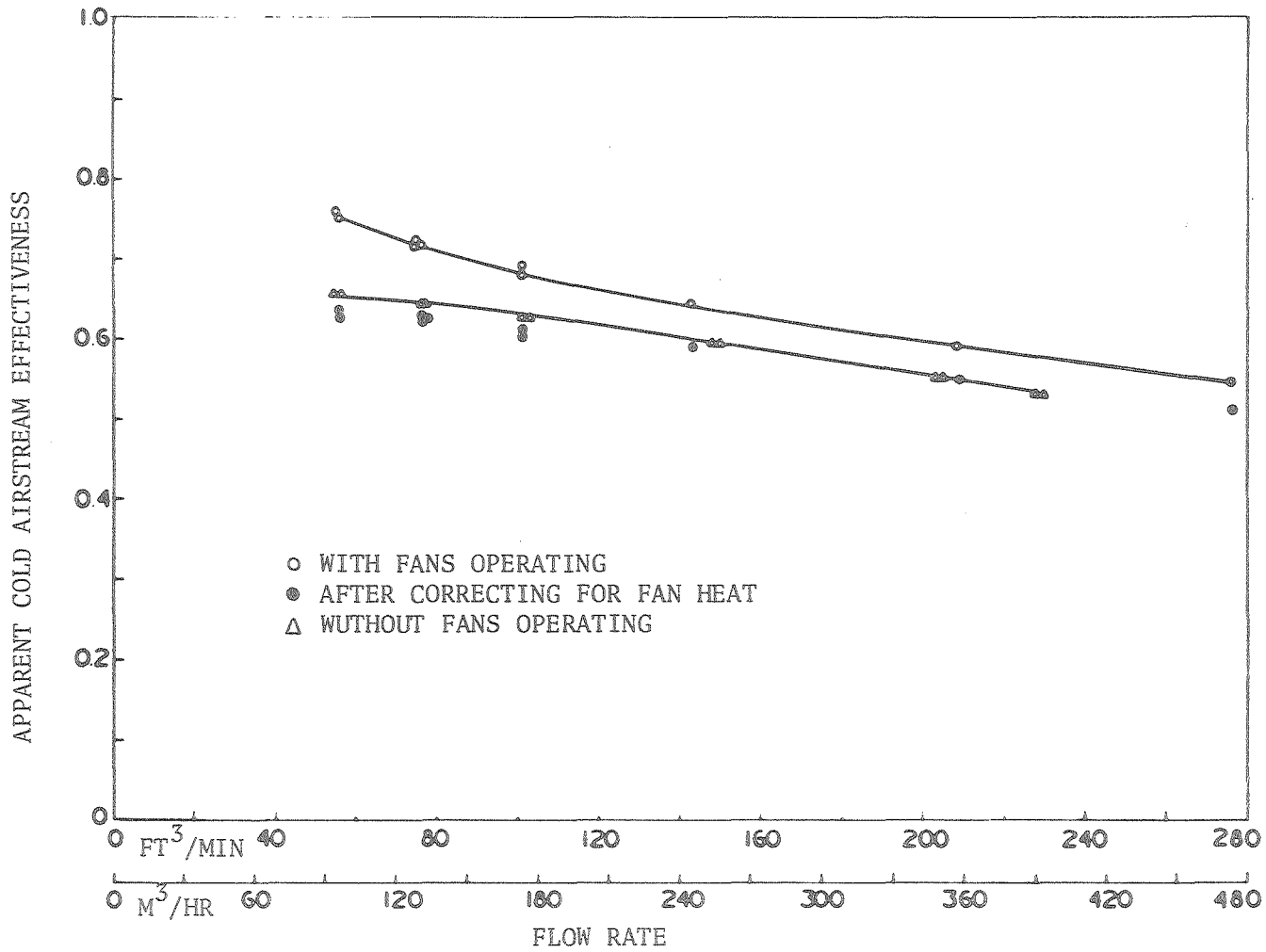

FIGURE 20. APPARENT COLD AIRSTREAM EFFECTIVENESS VERSUS FLOW RATE FOR THE FLAKT RDA heat EXCHANGER

XBL 809-11729



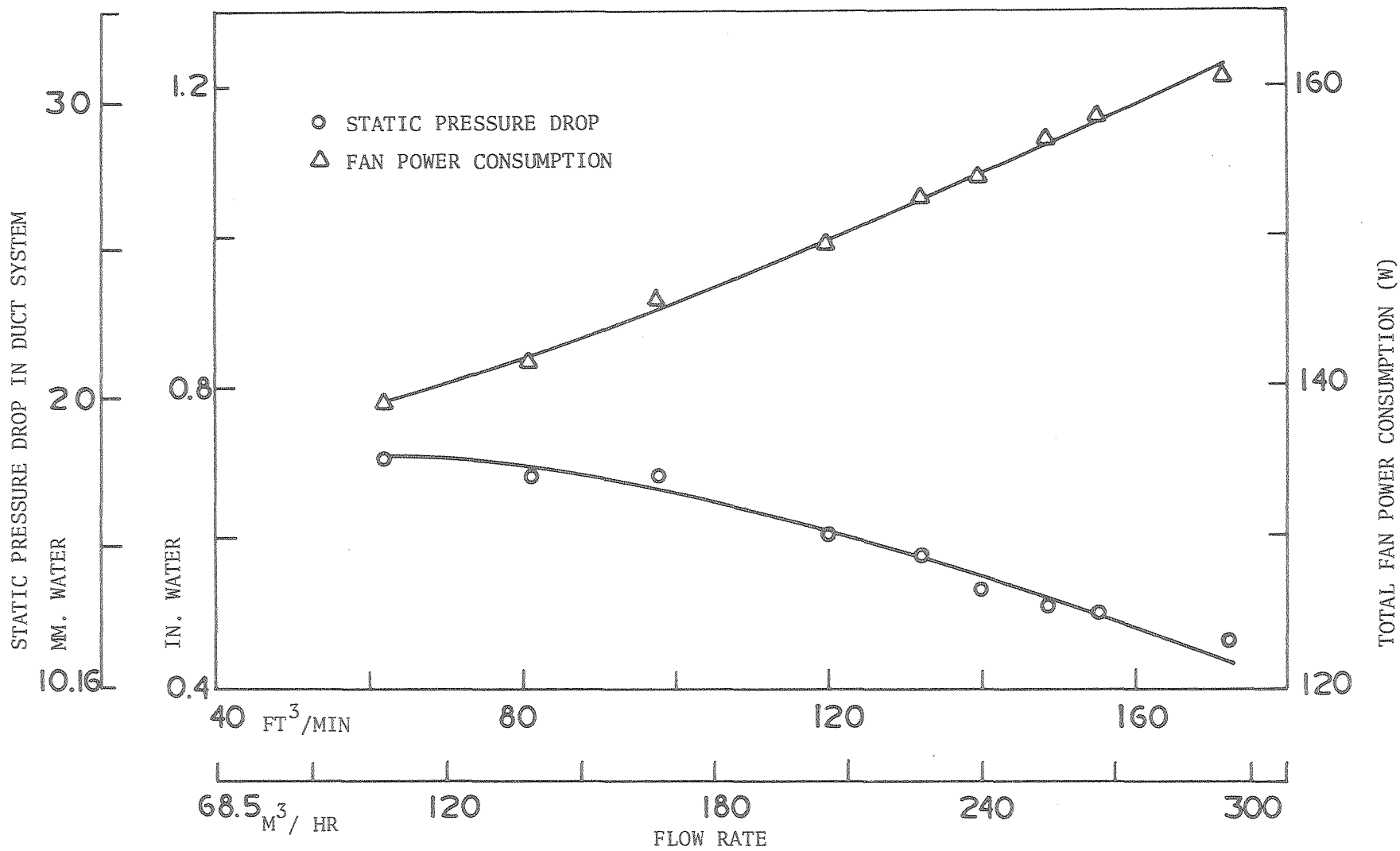

FIGURE 21. STATIC PRESSURE DROP IN DUCT SYSTEM AND TOTAL FAN POWER CONSUMPTION VERSUS FLOW RATE FOR THE FLAKT RDAA HEAT EXCHANGER-HIGH FAN SPEED

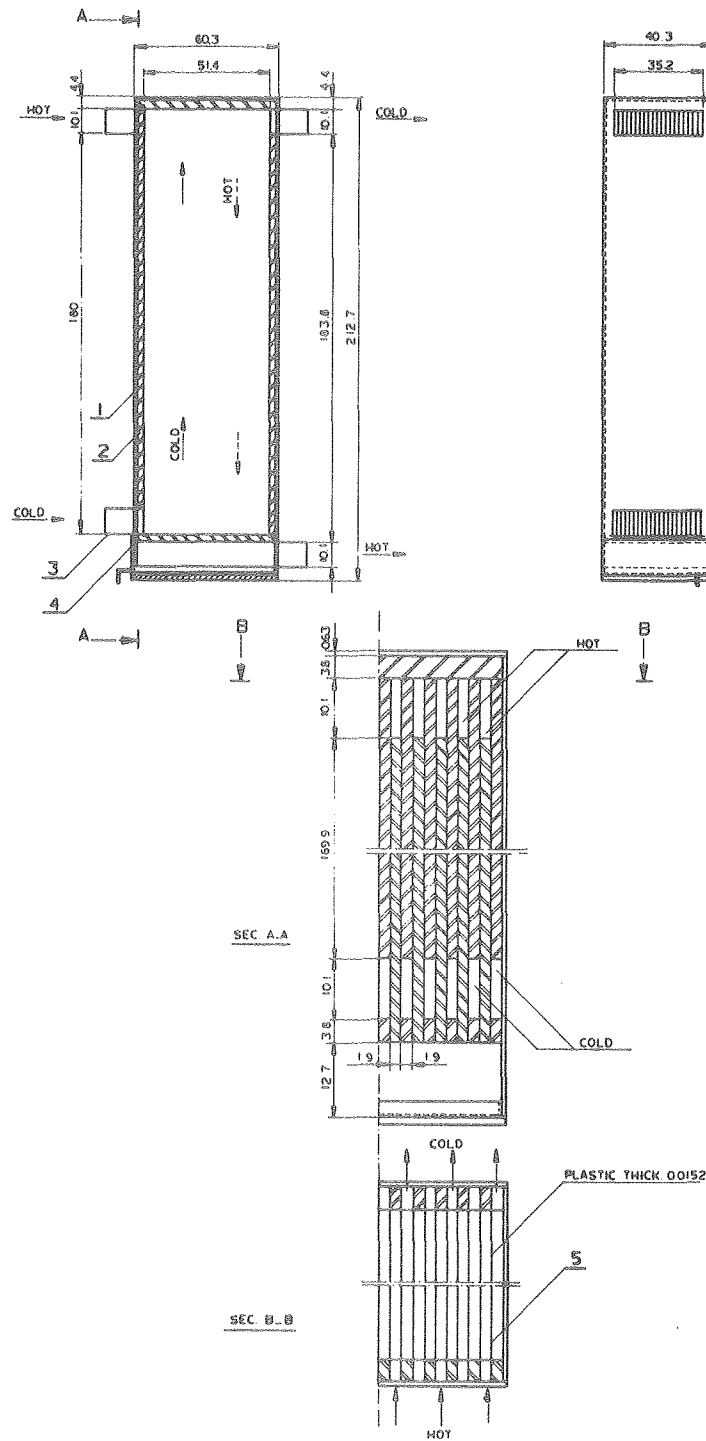
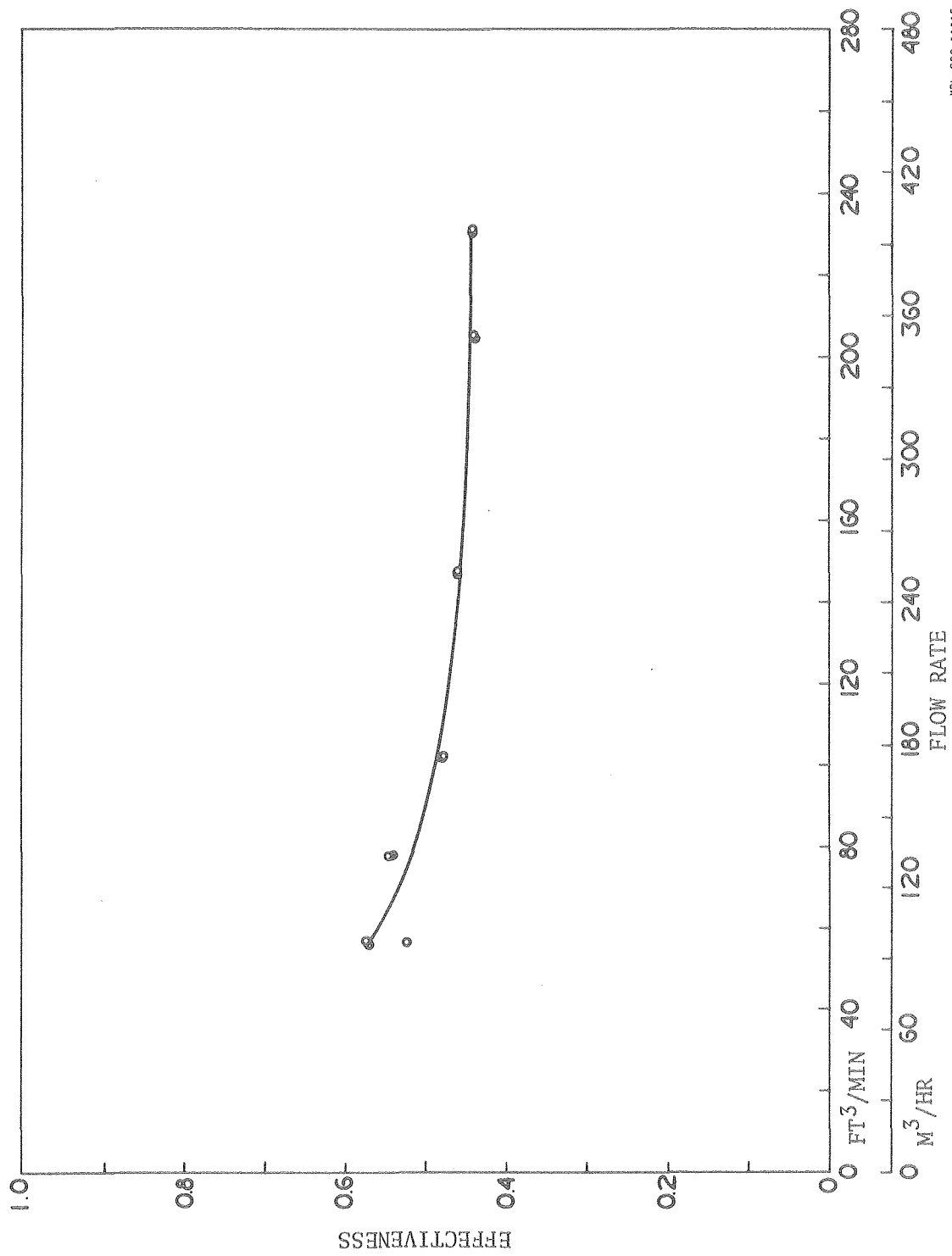

FIGURE 22. PLASTIC SHEET HEAT EXCHANGER

XBL 809-11727

IDENTIFICATION OF COMPONENTS FOR FIGURE 22

1. Pine Strip, 1.91 cm by 3.81 cm
2. Plywood Cover
3. Duct, Sheetmetal
4. Pan, Condensate Drain
5. Plastic Sheet



XBL 608-11015

FIGURE 23. EFFECTIVENESS VERSUS FLOW RATE FOR THE PLASTIC-SHEET HEAT EXCHANGER

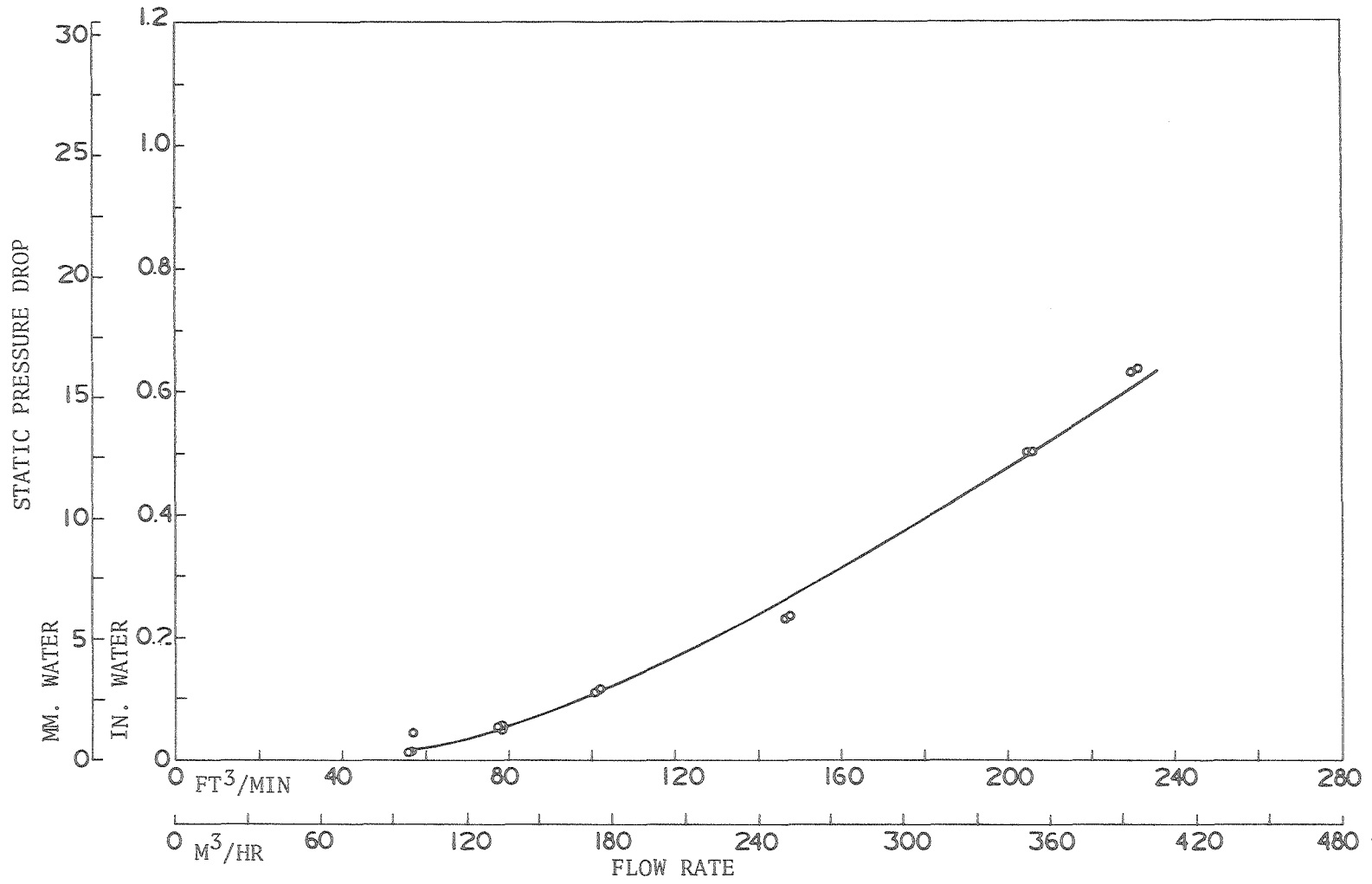
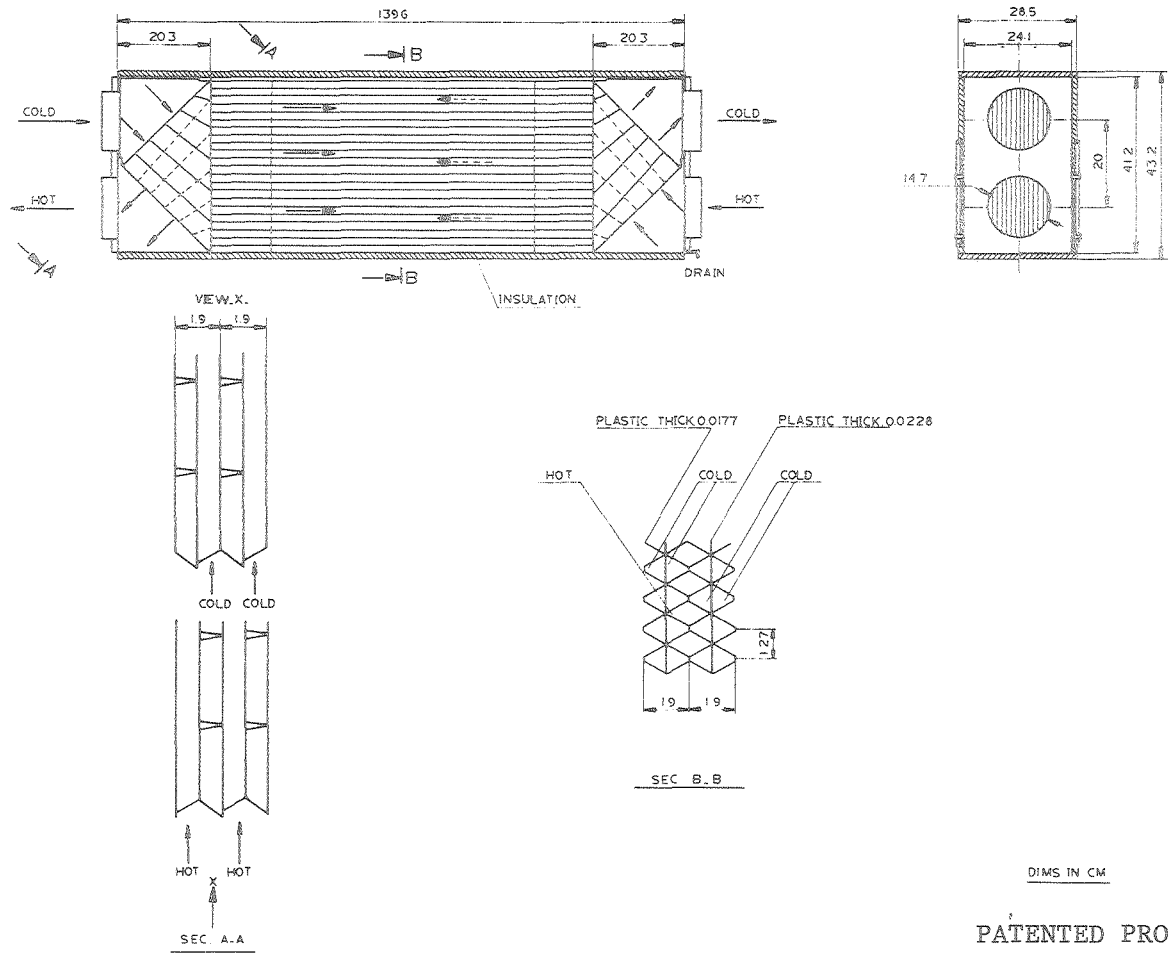

FIGURE 24. STATIC PRESSURE DROP VERSUS FLOW RATE FOR THE PLASTIC SHEET HEAT EXCHANGER

XBL 809-11739



DIMS IN CM  
PATENTED PRODUCT

XBL 809-11730

FIGURE 25. ALDES VMPI HEAT EXCHANGER

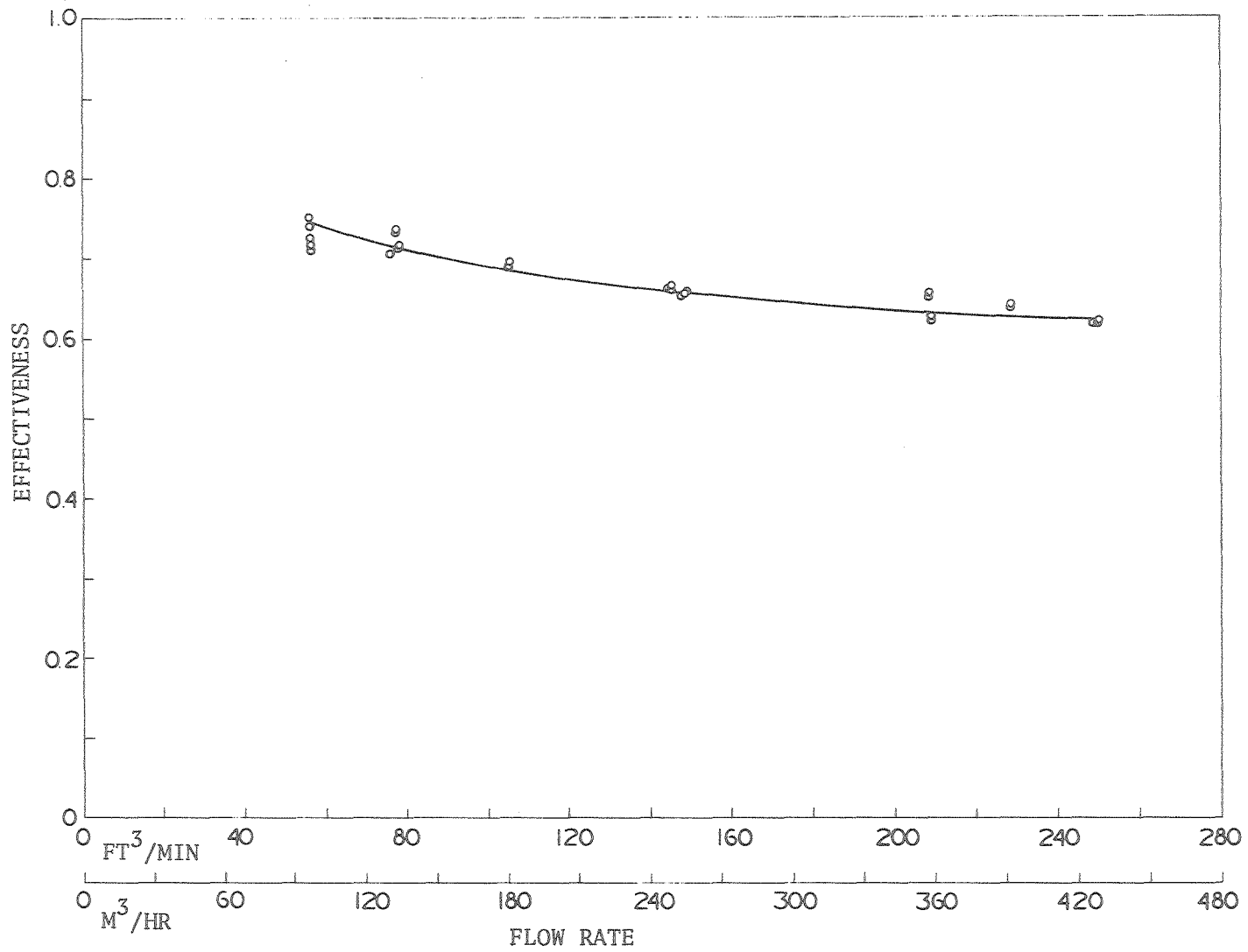

FIGURE 26. EFFECTIVENESS VERSUS FLOW RATE FOR THE ALDES VMPI HEAT EXCHANGER

XBL 808-11478

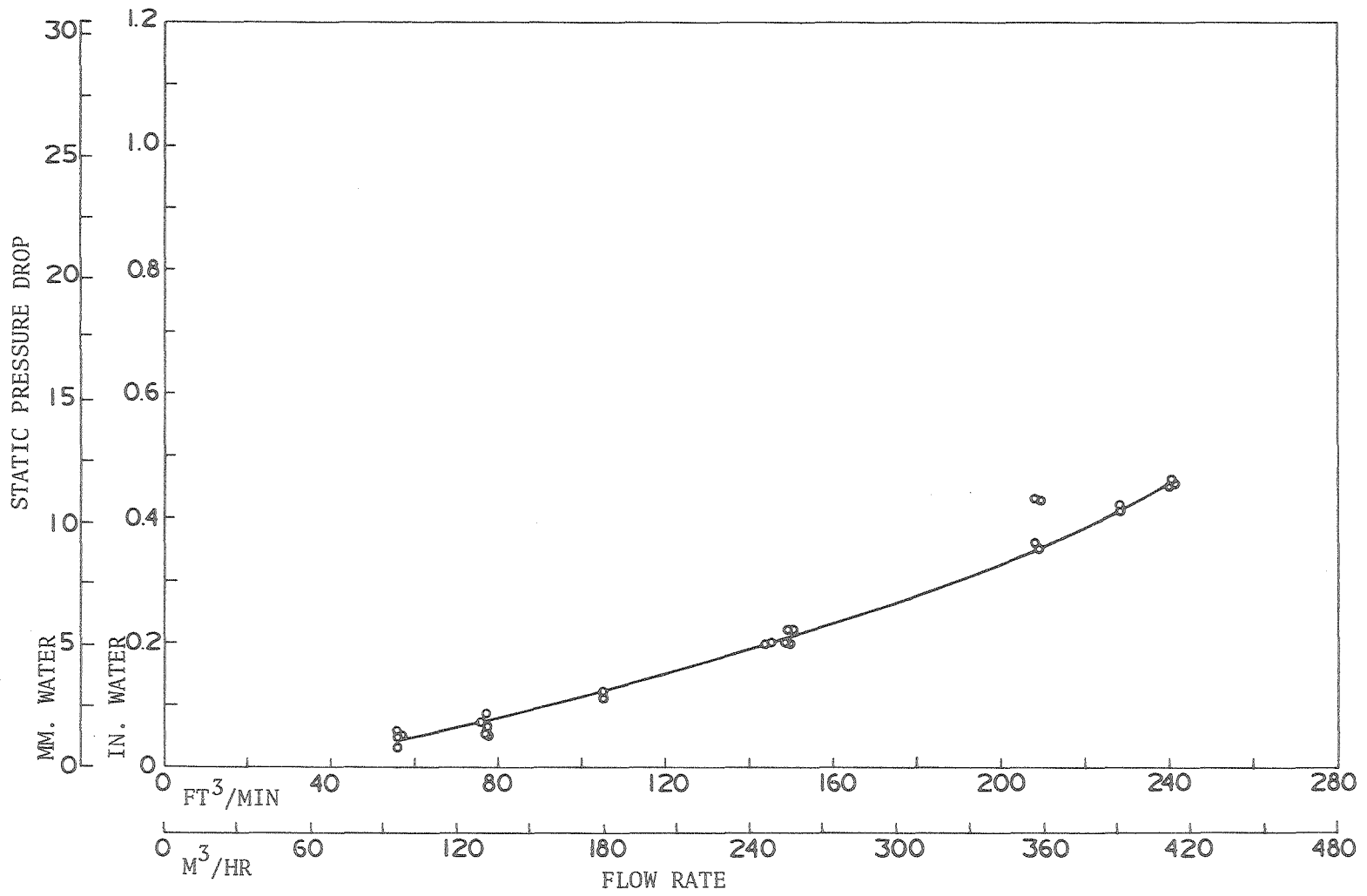
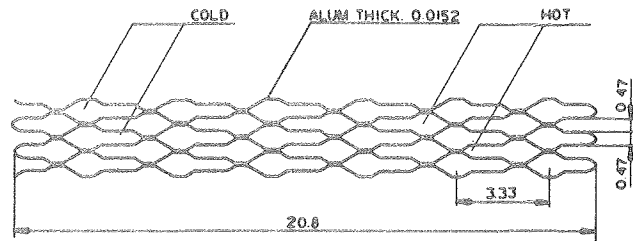
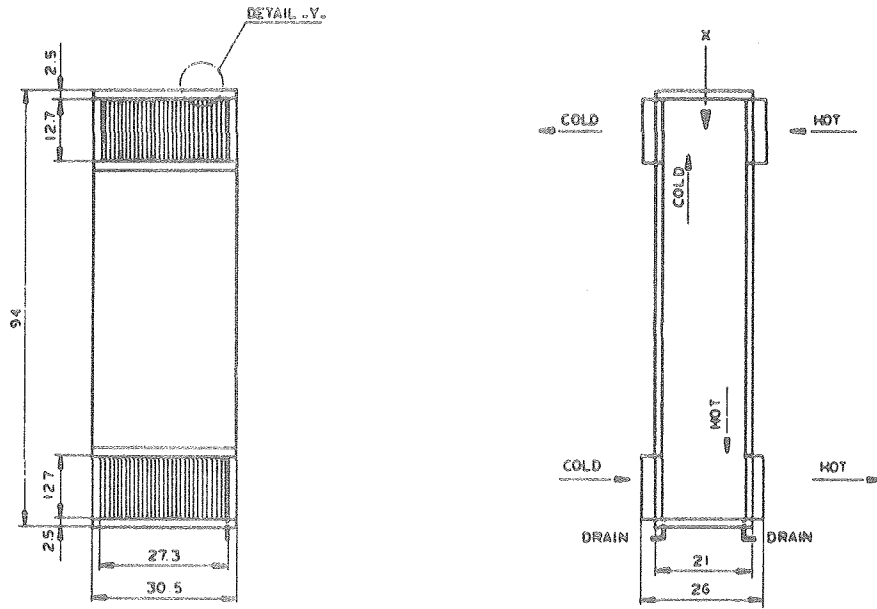

FIGURE 27. STATIC PRESSURE DROP VERSUS FLOW RATE FOR THE ALDES HEAT EXCHANGER

XBL 809-11740





VIEW .X.

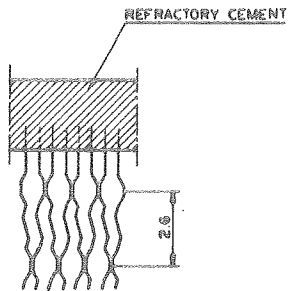

DETAIL .V.

DIMS IN CM

PATENTED PRODUCT

XBL 809-11725

FIGURE 28. DES CHAMPS MODEL 74 HEAT EXCHANGER

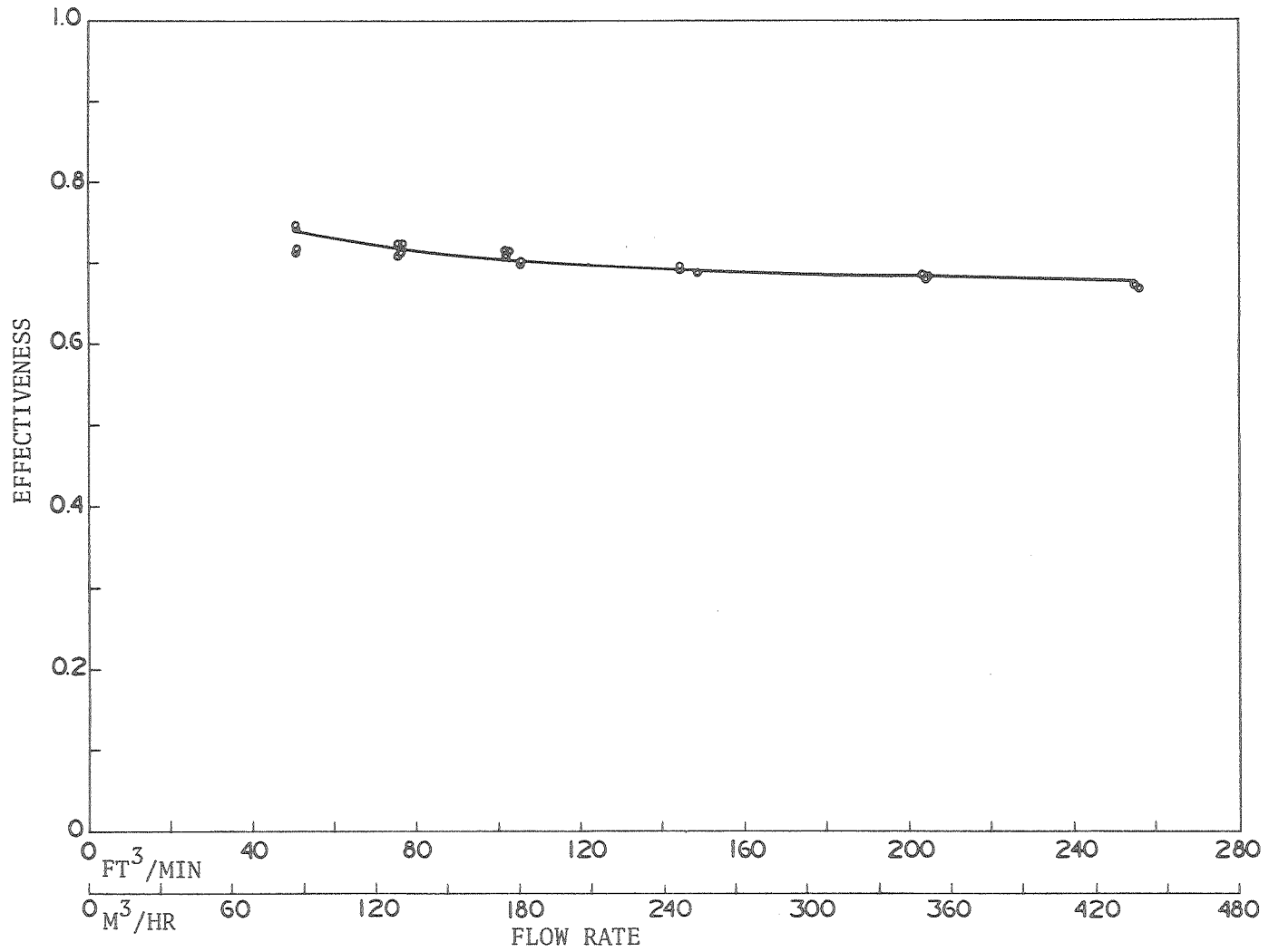

FIGURE 29. EFFECTIVENESS VERSUS FLOW RATE FOR THE DES CHAMPS XBL 809-11780 MODEL 74 HEAT EXCHAGER

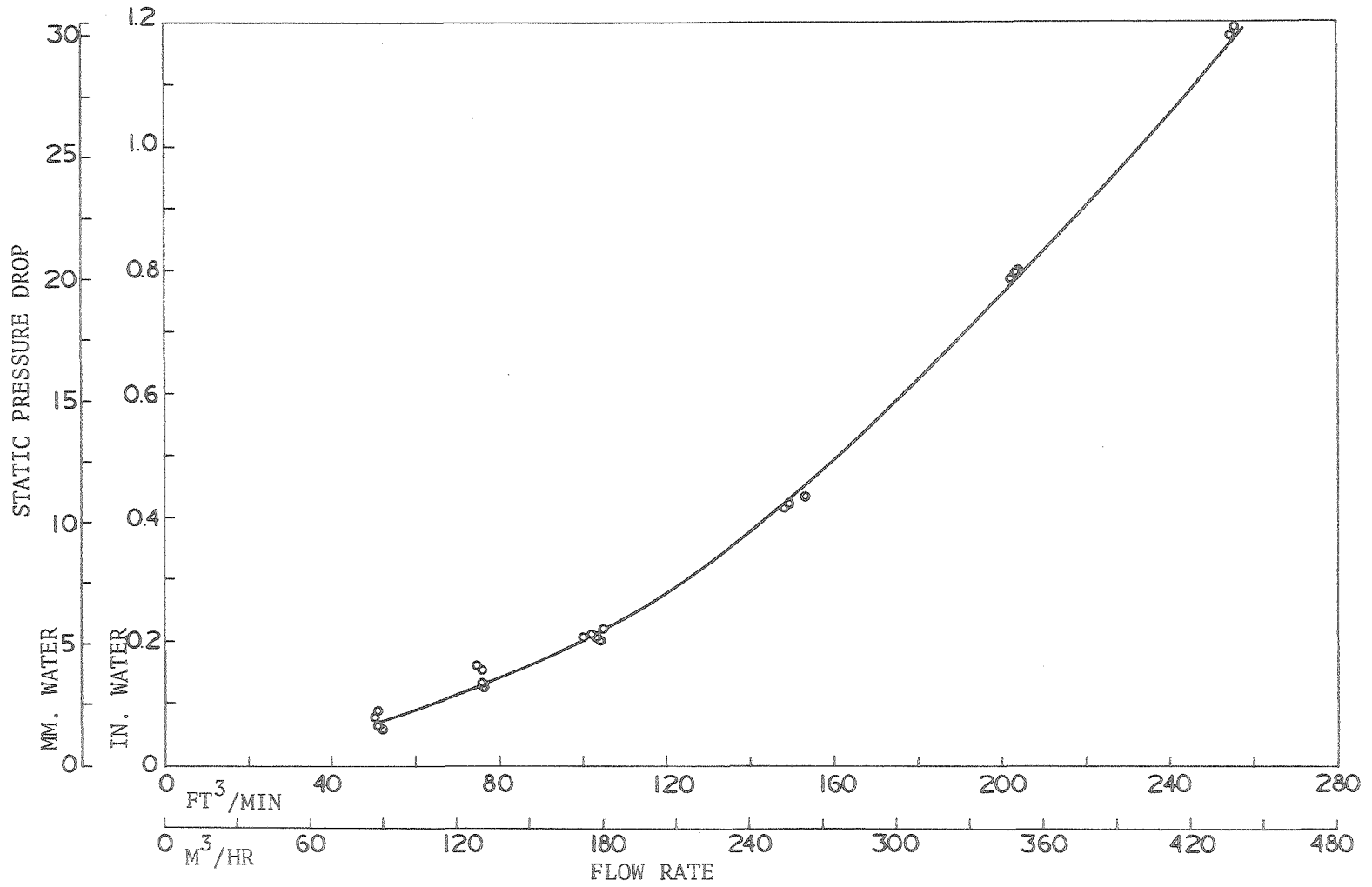

FIGURE 30. STATIC PRESSURE DROP VERSUS FLOW RATE FOR THE DES CHAMPS MODEL 74 HEAT EXCHANGER

XBL 809-11741