

Lawrence Berkeley National Laboratory

Recent Work

Title

The Advanced Light Source--Status Report

Permalink

<https://escholarship.org/uc/item/08q8m9c8>

Author

Jackson, A.

Publication Date

1991-05-01



Lawrence Berkeley Laboratory

UNIVERSITY OF CALIFORNIA

Accelerator & Fusion Research Division

Presented at the IEEE Particle Accelerator Conference,
San Francisco, CA, May 6-9, 1991, and to be
published in the Proceedings

The Advanced Light Source—Status Report

A. Jackson

May 1991

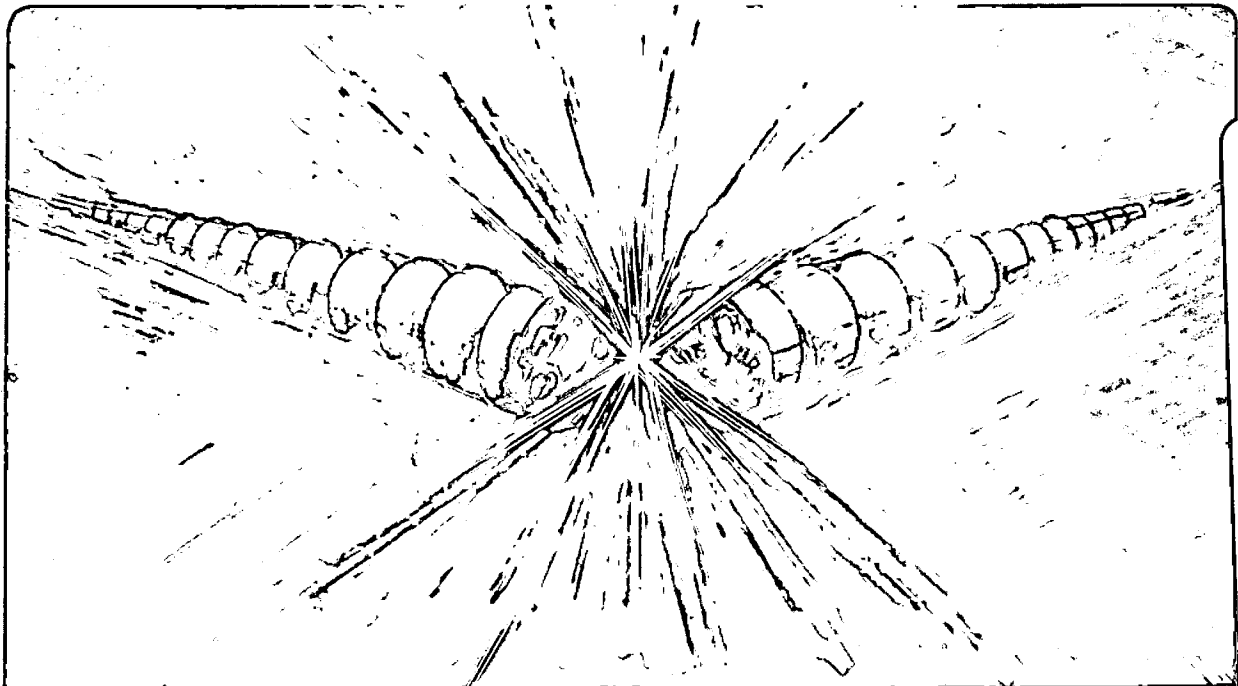

1 LOAN COPY 1
 1 Circulates 1
 1 for 4 weeks 1
 Bldg. 50 Library.
 LBL-29947
 Copy 2

DISCLAIMER

This document was prepared as an account of work sponsored by the United States Government. While this document is believed to contain correct information, neither the United States Government nor any agency thereof, nor the Regents of the University of California, nor any of their employees, makes any warranty, express or implied, or assumes any legal responsibility for the accuracy, completeness, or usefulness of any information, apparatus, product, or process disclosed, or represents that its use would not infringe privately owned rights. Reference herein to any specific commercial product, process, or service by its trade name, trademark, manufacturer, or otherwise, does not necessarily constitute or imply its endorsement, recommendation, or favoring by the United States Government or any agency thereof, or the Regents of the University of California. The views and opinions of authors expressed herein do not necessarily state or reflect those of the United States Government or any agency thereof or the Regents of the University of California.

The Advanced Light Source — Status Report

Alan Jackson

Accelerator Fusion Research Division
Lawrence Berkeley Laboratory
University of California
Berkeley, CA 94720

May 1991

Presented at the Particle Accelerator Conference, 6-9 May 1991,
San Francisco, CA

This work was supported by the Director, Office of Energy Research, Office of Basic Energy Sciences, Material Sciences Division, U.S. Department of Energy, under Contract No. DE-ACO3-76SF00098.

The Advanced Light Source - Status Report

Alan Jackson
 Lawrence Berkeley Laboratory
 Berkeley, CA 94720

Abstract

The Advanced Light Source (ALS), a national user facility currently under construction at the Lawrence Berkeley Laboratory (LBL), is a third-generation synchrotron light source designed to produce extremely bright beams of synchrotron radiation in the energy range from a few eV to 10 keV. The design is based on a 1-1.9-GeV electron storage ring (optimized at 1.5 GeV), and utilizes special magnets, known as undulators and wigglers (collectively referred to as insertion devices), to generate the radiation. The facility is scheduled to begin operating in April 1993. In this paper we describe the progress in the design, construction, and commissioning of the accelerator systems, insertion devices, and beamlines. Companion presentations at this conference give more detail of specific components in the ALS, and describe the activities towards establishing an exciting user program.

1. INTRODUCTION

The Advanced Light Source (ALS) construction project is now within two years of its scheduled completion date of March 31, 1993. The project includes a new building, accelerator systems, wigglers and undulators (collectively known as insertion devices), and beamlines.

Occupancy of the new building was taken in two parts in order to permit phased installation (and commissioning) of the technical components. The refurbished "Building 6," which once housed the historic 184-inch cyclotron, was finished in

early 1990 to permit installation of the ALS injector accelerators (a 50-MeV linac and 1.5-GeV booster synchrotron). The new 50,000-ft² addition to that building, which will house the storage ring, insertion devices, and experimental area, was completed in March 1991. Figure 1 is an aerial photo of the ALS building and its environs. The only major outstanding activity being coordinated by our conventional construction engineers is fabrication of the outer shielding walls and roof of the storage ring.

Table 1
 ALS Technical Facilities

Facility	Progress
Conventional Facilities	
Buildings	Complete
Shielding	In progress
Injection System	
Linac	Operational
Booster	Installed
Storage Ring	Installation started
Insertion Devices	Assembly started
Beamlines	Designs complete

By the end of 1990 the linac had been installed and the booster synchrotron was well on its way to completion. On February 20, 1991, a 33-MeV beam was successfully accelerated in the linac and transported down a diagnostics line. Two

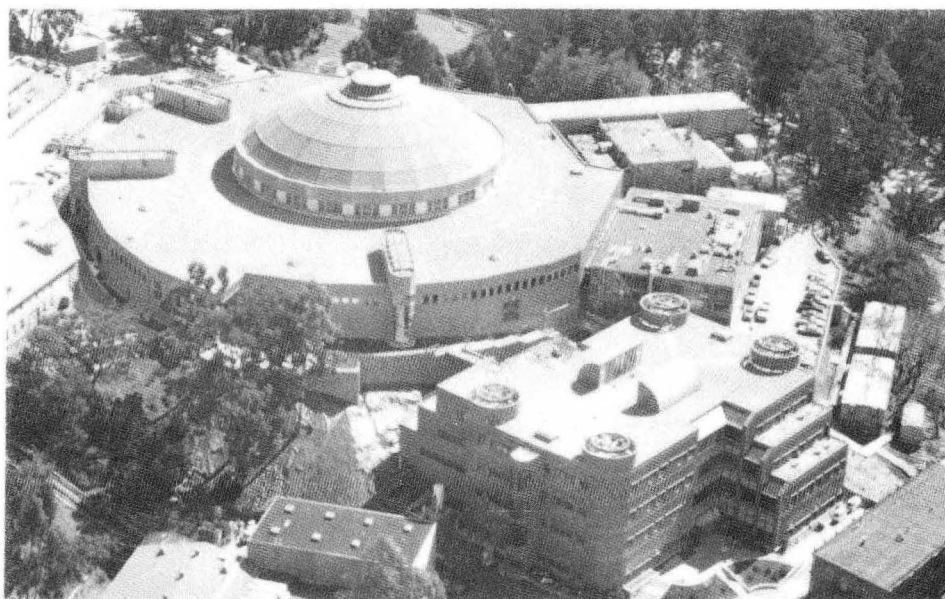

Fig. 1. The newly completed building housing the ALS. The Advanced Materials Laboratory is visible in the foreground.

weeks later the linac met its energy specification of 50 MeV. The booster synchrotron is now fully installed and we have begun commissioning with beam. Almost all components for the storage ring are on-site and are being readied for installation. Storage ring commissioning will start in early 1992.

Four insertion devices are being built with construction project funds: two U5.0s, one U8.0 and one W16.0. U denotes "undulator," W is for "wiggler," and the number is the period length in centimeters. Designs for the insertion devices being built in-house (two U5.0s and one U8.0) are complete, and assembly of components has begun. All 4600 permanent magnet blocks for the U5.0 undulators are on site and are being measured and characterized. The physics/engineering specifications for W16 have been sent to potential vendors for comments, together with a request for letters of interest. The conceptual designs for the front ends and beamlines associated with the U5.0 and U8.0 devices have been finalized, as has the design for a bend-magnet beamline to be used for storage ring diagnostics. Table 1 summarizes the status of the ALS technical facilities.

2. ACCELERATOR SYSTEMS

2.1 The Injection System

The injection system for the ALS comprises two accelerators: a 50-MeV linac, and a 1.5-GeV, 1-Hz "booster" synchrotron. All subsystems for these two accelerators have been installed in the refurbished domed building that once housed the 184-inch cyclotron. A phased approach to installing and commissioning the accelerators is being taken, with installation activities occurring during normal working hours and commissioning taking over in the evening. Commissioning activities on the linac are at an advanced stage, with the accelerator achieving its design energy on March 6, two weeks after beam was first accelerated. Details of the linac low-level rf system are given by Lo, Taylor, and Lancaster in paper HRA73. Emphasis is now on establishing routine linac operation and improving beam intensity and energy spread. A more detailed account of linac commissioning is given in a

paper by Selph and Massoletti (XRA11). Installation of the booster components began last summer when the first girder full of magnets was rolled into place. Since then, all systems have been installed, surveyed, aligned, and power-tested. The vacuum envelope was established at the end of April, when the final spool piece connecting the booster to the linac transport line was installed. Beam injection studies started May 3.

A paper describing a novel wideband, slot-coupled, beam-sensing electrode to be used in the booster is given by Hinkson and Rex (KRA34).

2.2 The Storage Ring

All major components for the ALS storage ring are either complete, undergoing final checks (e.g., magnetic measurements), or are in assembly, with the expectation that installation will begin this summer.

Magnets. All the gradient bend magnets, quadrupole, and sextupole magnets have been built and are in the process of magnetic measurements. To date all magnets that have been measured (a mix of all three types mentioned above) have fallen well within their permitted tolerances. Details of the measurements are given by Keller in paper PPH2. The fast kickers and septum magnets used for injection are almost identical to those used for booster extraction. One critical difference is the requirement on field penetration in the injection septum magnet. The solution to this, utilizing a copper-iron-copper sandwich, is discussed by Gabor et al. in paper PSC1.

Vacuum. The massive machined aluminum parts for the twelve novel-arc-section vacuum chambers are on site and being assembled. The first full-length prototype was used for R&D activities, including different methods of bakeout. This chamber (see Fig. 2) reached a base pressure of 2×10^{-10} torr. At this time the first production chamber is complete, the second is welded and assembled with its ancillary components (pumps, photon stops, etc.), the third is being welded, and the fourth is being cleaned in preparation for welding.

RF. Four nearly identical rf cavities are being built as part of the project: two for the storage ring, one for the booster, and a spare. The booster cavity has been power-tested and installed.

The spare cavity is being used to establish the viability of the cylindrical window (necessary for the higher power requirements of the storage ring cavities) and other specific features, prior to releasing the order for the storage ring cavities.

2.3 Controls

The thread (web?) that links all accelerator components in the ALS is its computerized control system. This is based on a highly distributed architecture (see Fig. 3) utilizing more than 600 intelligent local controllers (ILCs) providing most of the processing power at the controlled equipment. Operator control is achieved through IBM 386 PCs (recently updated to 486 processors), or, for the more complex control algorithms, via a workstation. The

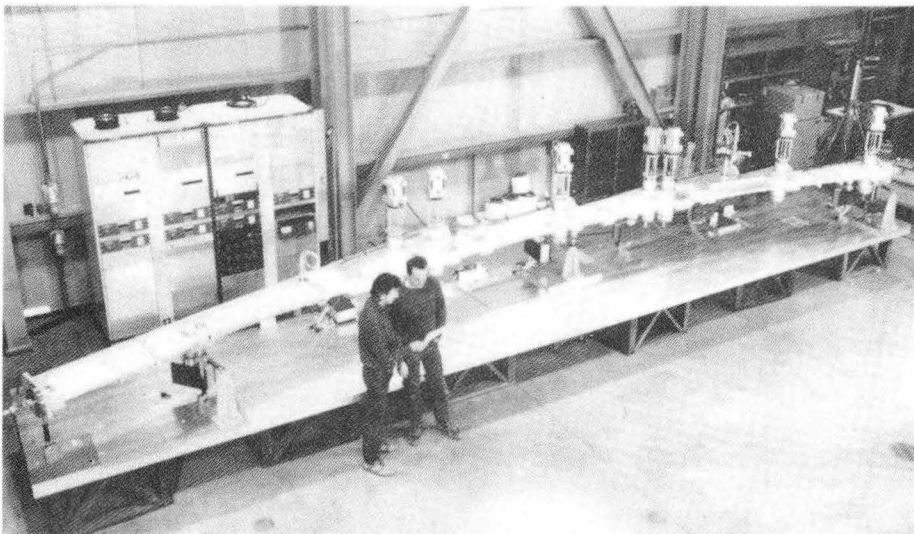

Fig. 2. Twelve of these curved vacuum chambers will be interspersed with twelve straight sections to form the complete storage ring.

CBB 8912-10805

system has been fully implemented for booster commissioning, and will be expanded as more controlled devices are added to the accelerator systems. Control and modelling software is described by Bengtsson et al. in paper KTP1.

3. INSERTION DEVICES

Four insertion devices are being built: three undulators (two U5.0s and one U8.0) and a wiggler (W16.0). Their main parameters and spectral coverage are shown in Table 2. Engineering details of the U5.0 are described by Hoyer et al., in TRA31, and other features of the magnetic elements are given in TRA37 (Hassenzahl et al.) and TRA38 (Marks et al.). The undulators are to be built in-house and the wiggler by industry. The time scale for fabrication shows the devices being ready for installation in the storage ring by the end of 1992.

Table 2
Main Parameters and Spectral Coverage of Insertion Devices

U5.0	
Period Length	5.0 cm
Number of Periods	89
Spectral Coverage (fundamental*)	52-380 eV
U8.0	
Period Length	8.0 cm
Number of Periods	55
Spectral Coverage (fundamental*)	8-237 eV
W16.0	
Period Length	16.0 cm
Number of Poles	33
Critical Energy	3.1 keV

*3rd and 5th harmonics give useful output because of the high quality of the undulator structures.

4. BEAMLINES

Three beamlines will be constructed, one each associated with the U5.0 and U8.0 undulators and a bend-magnet beamline to be used for machine diagnostics.

The beamlines can be logically divided into two sections: the front ends, which provide the safety functions and aperturing, and define the vacuum boundary between the storage ring and the remainder of the beamline; and the optical transport line (containing mirrors, filters, focusing elements, and monochromators), which delivers the tailored photon beam to the experimental stations. The designs of the front ends for both insertion-device beamlines and the diagnostic beamline

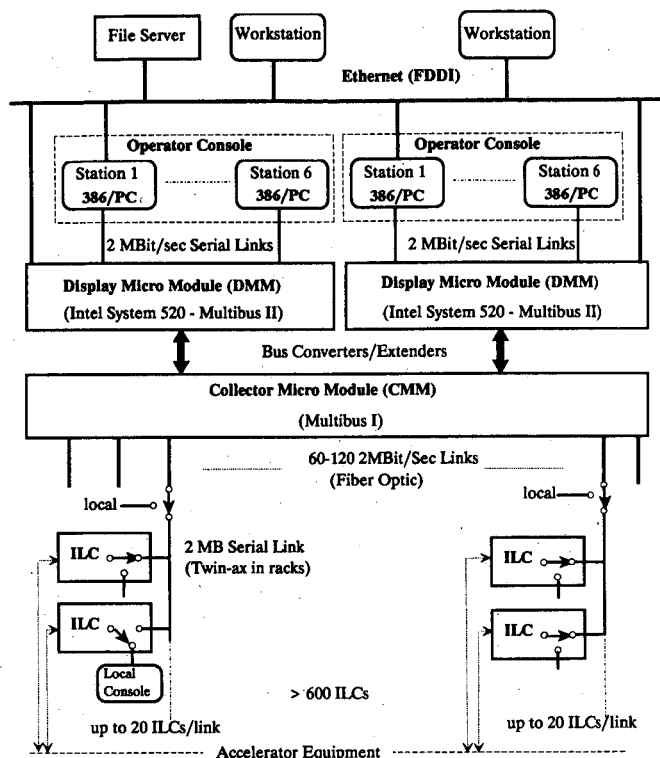

Fig. 3. The highly distributed architecture of the ALS computerized control system.

are in progress, and fabrication has begun. The optical transport lines are in an earlier stage of design. However, the long lead items for these beamlines, namely the water-cooled optics, have been expedited and are in fabrication in industry. A significant R&D program is also under way to support the beamline design effort. The main thrusts of these programs are: metrology, for the evaluation of optical surfaces; beam feedback, to assure photon beam stability at the sample under study; and finite-element analysis, to assess the impact of the high thermal loads and high power densities on optical components.

ACKNOWLEDGEMENT

This work was supported by the Director, Office of Energy research, Office of Basic Energy Sciences, Material Sciences Division, U.S. Department of Energy, under Contract No. De-AC03-76SF00098.

LAWRENCE BERKELEY LABORATORY
UNIVERSITY OF CALIFORNIA
INFORMATION RESOURCES DEPARTMENT
BERKELEY, CALIFORNIA 94720