

Lawrence Berkeley National Laboratory

LBL Publications

Title

Chemical and Photochemical Reactions of Thiocetic Acid and Related Disulfides

Permalink

<https://escholarship.org/uc/item/0nq6f1vr>

Author

Calvin, Melvin

Publication Date

1954-06-01

Copyright Information

This work is made available under the terms of a Creative Commons Attribution License, available at <https://creativecommons.org/licenses/by/4.0/>

UCRL-2607

UNCLASSIFIED

UNIVERSITY OF CALIFORNIA - BERKELEY

TWO-WEEK LOAN COPY

*This is a Library Circulating Copy
which may be borrowed for two weeks.
For a personal retention copy, call
Tech. Info. Division, Ext. 5545*

RADIATION LABORATORY

DISCLAIMER

This document was prepared as an account of work sponsored by the United States Government. While this document is believed to contain correct information, neither the United States Government nor any agency thereof, nor the Regents of the University of California, nor any of their employees, makes any warranty, express or implied, or assumes any legal responsibility for the accuracy, completeness, or usefulness of any information, apparatus, product, or process disclosed, or represents that its use would not infringe privately owned rights. Reference herein to any specific commercial product, process, or service by its trade name, trademark, manufacturer, or otherwise, does not necessarily constitute or imply its endorsement, recommendation, or favoring by the United States Government or any agency thereof, or the Regents of the University of California. The views and opinions of authors expressed herein do not necessarily state or reflect those of the United States Government or any agency thereof or the Regents of the University of California.

UNIVERSITY OF CALIFORNIA

Radiation Laboratory

Contract No. W-7405-eng-48

CHEMICAL AND PHOTOCHEMICAL REACTIONS OF
THIOCTIC ACID AND RELATED DISULFIDES

Melvin Calvin

June 10, 1954

Berkeley, California

Unclassified Chemistry Distribution

CHEMICAL AND PHOTOCHEMICAL REACTIONS OF
THIOCTIC ACID AND RELATED DISULFIDES*

Melvin Calvin

Department of Chemistry and Radiation Laboratory,**
University of California, Berkeley

ABSTRACT

June 10, 1954

The carbon cycle of photosynthesis is briefly reviewed in its entirety and the experiments involving it which led to the implication of disulfide rupture in photosynthesis are indicated. A review of the organic, physical and photochemistry of disulfides, with particular reference to the five-membered disulfide rings as they appear in thioctic acid, is given.

For publication in Federation Proceedings

-
- (*) Presented at symposium on "Metabolic Role of Lipoic Acid", Federation Meetings, Atlantic City, New Jersey, April 15, 1954.
- (**) The work described in this paper was sponsored by the U. S. Atomic Energy Commission.
-

CHEMICAL AND PHOTOCHEMICAL REACTIONS OF
THIOCTIC ACID AND RELATED DISULFIDES*

Melvin Calvin

Department of Chemistry and Radiation Laboratory, **
University of California, Berkeley, Calif.

Introduction

We have arrived at a fairly complete picture of the route by which carbon dioxide is converted into carbohydrate and other plant constituents. You may recall that the driving force for this reductive sequence of steps was a single reduction in which phosphoglyceric acid was reduced to phosphoglyceraldehyde. This and the other steps in the creation of the proper carbon skeletons are shown diagrammatically in Figure 1. We have called this the "photosynthesis cycle", and we shall use this term later in the discussion. It is driven by a single gear, the reducing power $[H]$, which has its origin somewhere in the photochemical reaction which splits water into active hydrogen, $[H]$, in some particular form, and active oxygen, $[O]$, which eventually finds its way into oxygen gas.

(*) Presented at symposium on "Metabolic Role of Lipoic Acid", Federation Meetings, Atlantic City, New Jersey, April 15, 1954.

(**) The work described in this paper was sponsored by the U.S. Atomic Energy Commission.

The basic form of this cycle was devised entirely on the basis of analytical, degradation, and kinetic studies with intact organisms using $C^{14}O_2$. (1) This has pointed the way for the search for simplified systems (cell-free enzymes, etc.) which might carry out one or another part of, or reaction in the cycle. The reduction of phosphoglyceric acid and the aldolase condensation to hexose have, of course, long been known in separated systems, and more recently since our discovery (2) of the widespread distribution of the sedoheptulose phosphate and ribulose phosphates, the transketolase system involved in the interconversions of triose, hexose, heptose and pentose has been separated and studied. (3,4,5) Finally, it may be of interest to point out that we have succeeded in demonstrating the presence in a cell-free preparation of an enzyme (or system of enzymes) capable of carrying out the carboxylation reaction specifically from ribulose diphosphate to phosphoglyceric acid. (6) This can be done with either of the reactants labeled and the distribution of the label in the resulting phosphoglyceric acid (PGA) indicates the carboxylation takes place as proposed. (1)

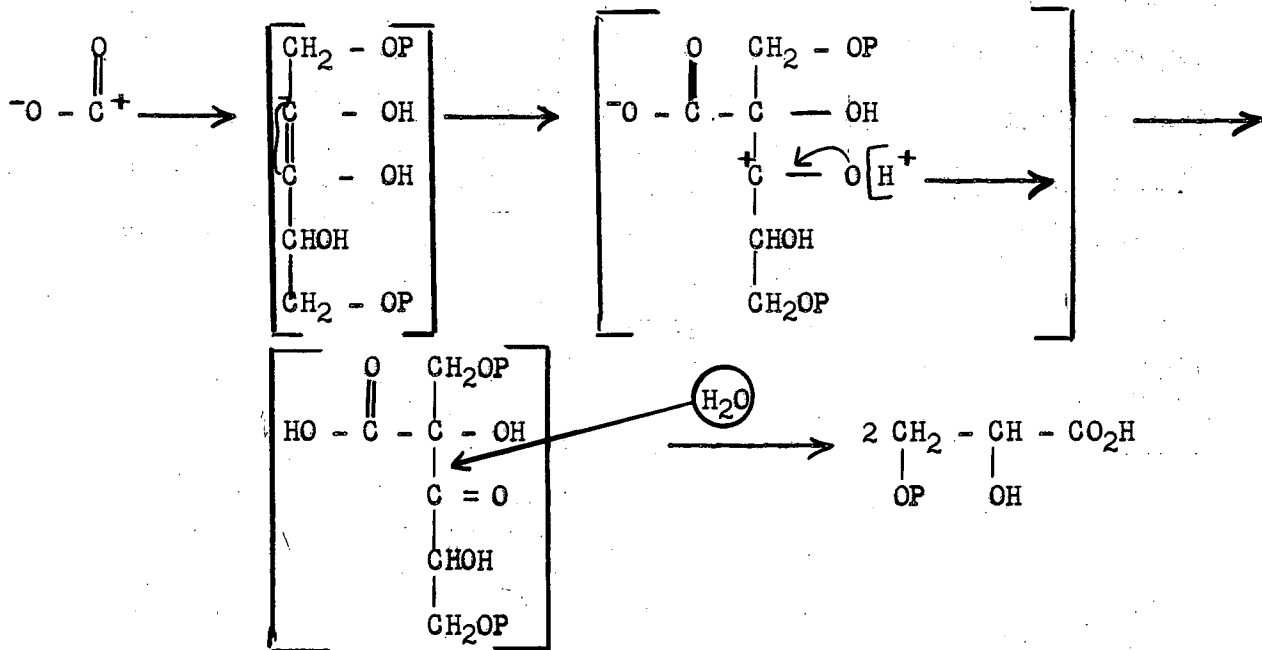

In order to understand our interest in cyclic disulfides and to justify my presence on this program, I want to amplify, or, if you like, use a high-power microscope on that square box marked **E** in Figure 1 and see if we can build it up in some detail which will be comparable to the one for the path of carbon.

It so happens that during the course of our study of the path of carbon some years ago, we encountered an experimental fact which required interpretation and gradually led us into the upper left-hand corner of this diagram. This fact was the following: While the light is on and we have algae in a steady state of photosynthesis and feed them radioactive carbon dioxide, that radioactive CO_2 does not appear in the compounds which normally are used for the generation of respiratory energy -- the so-called tricarboxylic acid cycle compounds (Krebs cycle compounds). Immediately the light is turned off after the radioactive carbon has gotten into some three-carbon compound such as phosphoglyceric acid, then radioactive carbon does find its way into the compounds of the tricarboxylic acid cycle. The tricarboxylic acid cycle is a sequence of reactions by which pyruvic acid, which is isoximeric with glyceric acid, is converted into useful energy and CO_2 by animal and plant organisms (citric acid or Krebs cycle). It is first converted to CO_2 plus an active acetyl which then condenses with oxalacetic acid to form citric acid. The citric acid goes on to aconitic acid, to isocitric acid, to oxal-succinic acid, to ketoglutaric acid, and back again to oxalacetic acid, through succinic, fumaric and malic acids. So we have the completed cycle (Figure 2). And in going through the cycle two atoms of carbon (the active acetyl) have been converted into carbon dioxide and useful energy has been made available to

the organisms, mostly in the form of so-called high energy phosphate -- the phosphoric anhydride bonds of ATP (adenosine triphosphate). Let us not be concerned with the details of this process except to recognize that it is a well-known one, and that in order to get radioactive carbon which is incorporated in phosphoglyceric acid into the citric acid cycle, one has to pass through the active acetyl stage. The important observation is that while the light is on, we don't see radioactivity appearing in these compounds (Figure 2) very rapidly. It gets into pyruvic acid, glyceric acid and the compounds we discussed earlier -- the photosynthesis cycle (Figure 1). However, when the light is turned off, there is immediate appearance of radioactive carbon from phosphoglyceric acid into the compounds of the Krebs cycle and their close relatives. This phenomenon is shown for two different types of experiment in Figure 3 (7) and Figure 4.

Thus, we can say, without any ambiguity, that there must exist a connection between the photosynthesis cycle, which you saw in Figure 1, and the respiratory, or citric acid cycle, in Figure 2, which is blocked in some way when the light is on. This can be represented schematically in Figure 5. Normally, when the light is on, most of the radioactive carbon which enters via photosynthesis has to pass through the large pool of fats, proteins and carbohydrates before it gets to the tricarboxylic acid cycle and makes energy available to the plants or animals. However, as soon as the light is turned off, there is made available at least, in part, a new connection, and a much shorter one (the dotted line in Figure 5) between the photosynthesis cycle and the tricarboxylic acid cycle. It behooves us to determine what the nature of that connection is, behaving as it does, like a valve opening in the dark and closing in the light.

About two years ago, the enzyme system which carries the three-carbon piece across this gap into the citric acid cycle was recognized. The coenzyme required to get pyruvic acid over into the citric acid cycle was given the name "pyruvic acid oxidase factor", and it was recognized as a specific type of sulfur compound in late 1951. This was really the only way that was known, then, of carrying pyruvic acid over into the citric acid cycle. The experimental fact that light blocked this carry-over focussed our attention on the relationship of light and the "pyruvic acid oxidase factor". Figure 6 will show in some detail the nature of that pyruvic acid oxidase factor as it was determined both by the group at Lederle Laboratories and at the University of Illinois and Lilly Laboratories. It is a five-membered cyclic disulfide -- 6,8-dithio-octanoic acid -- and the pyruvic acid coming from the photosynthesis cycle, i.e. from phosphoglyceric acid (because this is the first three-carbon compound to form) is decarboxylated to form acetyl thioctic acid. The factor appeared in four other places under four other different names. They were all finally recognized to be one and the same thing. The names are shown in Figure 6. The term thioctic acid is the one I prefer since it most nearly describes the chemical and has been used by the first people to synthesize it, namely, the group at Lederle. (They have invented the term thioctic acid to describe the synthetic material and this is the term I shall use.) Acetyl thioctic acid is thus formed by the reaction of pyruvic acid and thioctic acid (with the cooperation of a thiamin compound) giving off CO_2 . This active acetyl, then, undergoes a thiol exchange with coenzyme A (CoA) to form dithiooctanoic acid and acetyl CoA. (I shan't trouble you with the whole structure of CoA here, except to point out that the sulfur of CoA is on the tail-end of a nucleotide-

like structure, being the SH group of a mercapto ethanolamide residue.) This, then, is the active acetyl which condenses with oxalacetate and brings the two-carbon fragment from pyruvic acid into the citric acid cycle. These appear to be the essential features of the reaction by which the "pyruvic acid oxidase factor" functions.

Our first proposal was that the reducing power generated by the light simply reduced the disulfide to the dithiol and thus shifted the steady-state ratio of the forms of thioctic acid in favor of the dithiol form. The dithiol is incapable of oxidizing pyruvic acid to form acetyl thioctic and CO_2 , and so in the presence of high intensities of light, since there was very little disulfide (most of it was in the form of dithiol) the connecting direct route between pyruvic and the citric acid cycle is closed, or at least is narrowed down. As soon as the light is turned off, however, the disulfide is not being reduced by the action of the light -- it is rather being oxidized, with the oxidizing agent being a pyridine nucleotide which itself is then reduced. Since it is being oxidized, the steady-state amount of disulfide is higher in the dark and therefore there is more of it to carry the pyruvate over into the citric acid cycle. The direct connection between the photosynthesis cycle and the citric acid cycle is thus made in the dark.

This was our suggestion, then, in the summer of 1952 without being any more specific as to how the light might achieve this shift of steady-state -- this shift of equilibrium -- from disulfide to dithiol.

About that time, I received from Dr. T. H. Jukes at the Lederle Laboratories, some samples of this thioctic acid. The history of that is rather interesting, and I thought I might take a minute to tell you about the sequence

of events which brought up the whole question of thioctic acid again. It is as follows: Dr. Jukes had sent me 20-30 mg. of what they believed to be the pyruvic acid oxidase factor -- synthetic thioctic acid -- in February 1952. I had opened the package and looked at the 20 mg. of nice colorless crystals and thought someday we would figure out something to do with these crystals and tucked them away in the icebox. Some weeks later, there appeared a note in The Journal of the American Chemical Society (8) saying (this is again from the Lederle group), "We were wrong". The first proposal that the pyruvic acid oxidase factor was a six-membered ring of this character

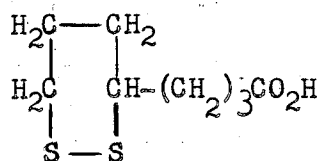

(I)

5-thioctic acid

was in error; that the really active material was a five-membered ring, the isomer of 6,8-thioctic acid, having this structure:

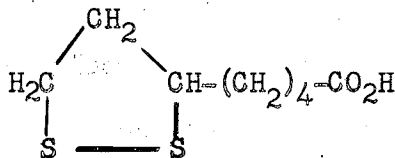

(II)

6-thioctic acid

(I) was not the active principal but (II) was. I wrote to Jukes asking which sample he sent me, and to please send the other one now. So, he did -- he sent me another sample -- and it turned out that the first one he had sent me was

indeed (I), and when he sent me (II) it was quite a different thing. (II) was not white crystalline material which looked pretty much like naphthalene (that's what the first sample had looked like); it consisted of nice yellow crystals. Now to an organic chemist, the pale yellow color of crystals generally doesn't mean very much -- the yellow could be there for a whole variety of reasons, having little to do with the nature of the principal compound present. On the bare chance that it might be significant, I suggested that we had better determine the quantitative absorption spectrum of each of the samples. The spectra were quite different, indicating that the yellow color which appeared in (II) was perhaps a genuine difference of (II) from (I).

About that time also we had a visitor in our laboratory, Dr. John A. Barltrop from Oxford University, and he was starting to do some experiments with radiocarbon in the usual fashion which visitors do in our laboratory. We discussed this spectroscopic observation with the view of obtaining a small sample of a disulfide ring, without any side chains, and with only three carbons in it, to see what its spectroscopic properties were -- to see if there was something really queer about this five-membered disulfide ring. He said he could do that -- it would just take a day or so -- and what he did was to make the trimethylene disulfide by heating together trimethylene dibromide and sodium disulfide, in alcoholic solution. Upon distilling off the alcohol, he got a clear yellow distillate. That yellow stuff in the spectrophotometer gave exactly the same spectrum that we had for the 6-thioctic acid which we had obtained from Lederle. Dr. Barltrop didn't touch carbon-14 for the rest of the year. He spent all his time on the chemistry of this five-membered ring and the six-membered ring which he also

made, to define precisely the difference between them -- what were the essential characteristics of the five- and six-membered rings which seemed to make the five-membered important in pyruvic acid oxidase while the six-membered ring didn't function well at all.

Physics of the Cyclic Disulfides

Figure 7 shows a model of 6-thioctic acid; these are photographs of scale models of thioctic acid, showing the relation of the carboxyl group and the five-membered disulfide. The second molecule is there simply because the 8-methyl-6,8-thioctic acid happens to be the only antagonist we have today, as yet, to 6,8-thioctic acid. If we have time, we will discuss something of the chemistry of that as well. The spectra are shown in Figure 8. Here you see the spectrum of the 6,8-thioctic acid, the five-membered ring (It's a little confusing. The 6,8-thioctic is the five-membered ring, and the 5,8-thioctic is the six-membered ring, and the 4,8-thioctic is the seven-membered ring.) compared with an open-chain disulfide spectrum. You can see quite a pronounced trend, both in the position of the absorption peak and its intensity. This shifting of the absorption spectra from the ultraviolet toward the visible, as we make the ring smaller, has important consequences. It immediately suggested to us that as we made the ring smaller we introduced into the ring a strain which was more or less located in the sulfur-sulfur bond. It was this strain, introduced in some way and for reasons as yet undetermined, which was responsible for the peculiar position of thioctic acid

(the five-membered ring) in biochemistry. It also went one step further. It suggested -- why it suggested this I'm not exactly sure, but it did -- that perhaps the thioctic acid was itself acting as the acceptor of the energy from the chlorophyll molecule without the intervention of any intermediary conversion: i.e. that it was the converting agent. Why this should be will appear in a little while.

The problem, then, was to understand, if possible, the nature of the spectral changes, and examine the physical and organic chemistry of these disulfide compounds, both the chain and ring alike, and find out what the unique characteristics of these ring compounds might be. In order to do this, we proceeded to make use of the five-, six-, and seven-membered rings which had no side chains on them to confuse the issue and the models of these are shown in Figure 9. It shows the open chain, and the six-membered and the five-membered ring -- the seven-membered ring isn't shown here. One outstanding characteristic was immediately apparent in this series. The dihedral angle between the carbon-sulfur bonds, which in the open-chain disulfide can have any value, must be very near to zero degrees in the five-membered ring. This suggested a search of the literature to see if any information was available by any method of observation with respect to the introduction of strain into such a ring as this. I might say first of all that there is in cyclopentane an amount in strain energy which is about 5 Kcals. and so one might expect a similar strain energy here, although the two sulfur atoms change the geometry of the ring a great deal. There was, however, available in the literature information about the barrier to rotation about the sulfur-sulfur bond in some simple disulfides. Heat capacity measurements (9) on dimethyl disulfide and

diethyl disulfide indicated that there was a rotational barrier to the coplanar position -- in other words, the 180° dihedral angle -- of between 10-15 Kcals. This is a very large rotational barrier for what purports to be a single s-type bond. Figure 10 shows the geometry of the C-S-S-C system (10) and shows a possible reason for the rotational barrier in the disulfide; it is an overlap of the p_{1z} and p_{2z} orbitals on the two sulfur atoms (11) -- I don't think we want to go into that at the moment. The evidence is then that the stable configuration of a disulfide has a 90° dihedral angle, and that any departure therefrom involves an introduction of strain energy which could amount to 10 or 12 Kcals. in the 180° position and would be expected to be larger in the zero degree position, because of not only the rotational barrier of the disulfide but also the shift of the carbon-sulfur bond angles themselves. One could estimate this in a variety of ways; we tried to do it with infrared frequencies which were measured for the trimethylene disulfide, the tetramethylene disulfide and the pentamethylene disulfide, but this did not prove to be easily and unequivocally possible.

Another mode of estimating the strain energy in the trimethylene disulfide, and the tetra-, for that matter, might be the ultraviolet spectrum itself. If one makes the assumption that upon the absorption of light in these first absorption bands the excited state is one in which the bond between the two sulfur atoms is broken, then it would make little difference to the energy of the excited state how many carbon atoms lay between the two sulfur atoms. One could then, for a first approximation, suppose that most of the energy difference in the spectra of the three compounds was due to difference in the energy of the ground state. Figure 11 is a diagrammatic representation of this,

with a calculation on that basis. Thus, if we assume as a first approximation that the excited state (U) for all of the disulfides has very much the same configuration, that is, the sulfur-sulfur bond is no longer present, then using the r subscript for the ring compound and the o subscript for the open-chain we may represent the energy of the various states as a function of S-S distances by ordinary Morse Curves. Thus the transition at the absorption maximum for the five-membered ring (3300 \AA) corresponds to 86 Kcals., while that for the open-chain compound (2500 \AA) is 113 Kcals. Using our first approximation that the excited states are the same, i.e. $\Delta_U = 0$, then the difference between 86 Kcals. and 113 Kcals. would all be assigned to the difference in the ground states. This amounts to 27 Kcals. That would make the strain energy in the five-membered ring as high as 27 Kcals. This is certainly a maximum or upper limit value, since Δ_U is surely not zero. Thus we have at least one way of estimating the upper limit of the strain energy in the five-membered ring as 27 Kcals. Now we have two estimates -- one from the ultraviolet spectrum giving 27 as a maximum (something less than that, in other words); and another estimate from the heat capacity data giving a minimum of somewhere between 10-15 Kcals. Now, let us see if we can find some direct experimental demonstration of this strain energy.

Chemistry of Cyclic Disulfides

There are several ways in which this can be done. We proceeded to examine, for example, the reducibility of these disulfides. We found that zinc in hydrochloric acid was really the only reducing agent we could use --

borohydride doesn't reduce the disulfide. Zinc and acid, a heterogeneous reducing system, reduces the five-membered disulfide almost instantly at room temperature. The six-membered disulfide takes longer; the open-chain disulfide actually must be heated. Another anomalous property of the trimethylene disulfide is its inability to react with HCN.

But these are qualitative observations, and we would much prefer to have a quantitative measurement, if possible, of this manifestation. Another reaction which we examined for this five-membered disulfide is the reaction with mercaptans. We found that any mercaptan at pH's approaching 8, where it was really mercaptide anion, would react with the five-membered disulfide, opening it, to form an open-chain disulfide of this character:

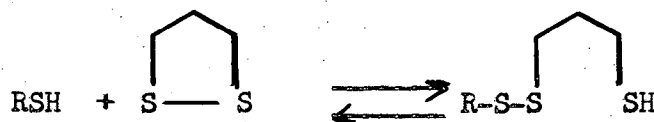

This reaction was found to be rapid, at pH's around 8, and reversible. An equilibrium was established. We measured that equilibrium at two temperatures, 25° and 35°, and got a ΔH for this reaction of about - 7 Kcals. Now that isn't a very accurate measurement and it might even be twice that, since we had only a ten degree temperature difference to work with. You will notice that the only difference between the reaction on the left-hand side and the right-hand side is that on the left-hand side the disulfide is in the five-membered ring, in the right-hand side the disulfide is an open chain. Otherwise, the bonds are the same; one mercaptan and one disulfide

on each side. So the ΔH , then, presumably, represents the strain energy, to a first approximation, of this cyclic disulfide. That was one measurement; it was disappointingly small compared to the two other estimates that we had made, but it was the only one -- and still is the only one -- that was a direct equilibrium measurement.

Another thermal reaction -- before we come to the photochemistry of the disulfides -- was the reaction of the disulfide with a peroxide, to be specific with ammonium persulfate, to form a thioisulfonic ester (or sulfenic anhydride):

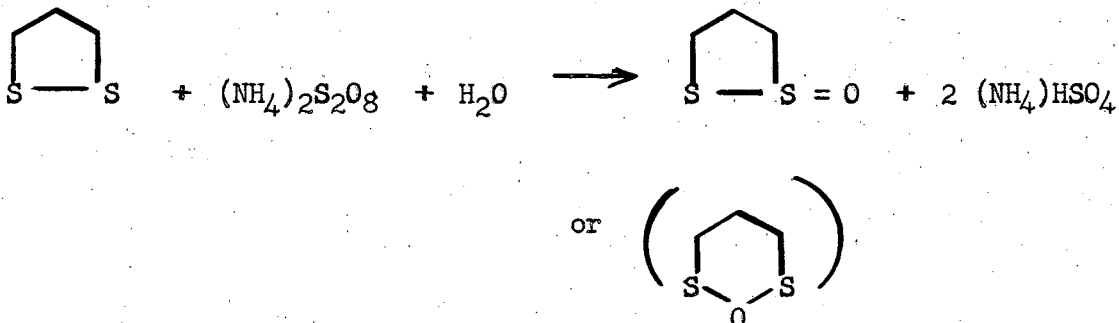

This turned out to be a very nice reaction, easily susceptible of quantitative measurement. The method was again a spectroscopic one, depending upon the disappearance of the 3300 Å cyclic disulfide absorption band. Figure 12 shows the oxidation of the disulfide carried out by ammonium persulfate. Curve 1 is the absorption spectrum of the initial disulfide and then curves 2,3,4,5,6,7 are a series of successive spectra at different times, after ammonium persulfate is added to the reaction mixture. Curve 8 is the same reaction mixture as gives curve 7 diluted ten-fold so that we can see the absorption spectrum of the monoxide perfectly clearly defined.

It's not immediately obvious that the reaction is uncomplicated, but here we have an isobestic point, a very clean-cut one, which indicates that for every disulfide molecule which disappears a monoxide molecule is formed, and there are no unstable or transient intermediates which would throw off the stoichiometric relationship.

Kinetically this appears to be a bimolecular reaction, and we thus were able to measure quantitatively the rate constants for the oxidation of the disulfide to the disulfide monoxide for two different five-membered rings -- the 6-thioctic acid and the 8-methyl-6-thioctic acid -- for a six-membered ring -- 5-thioctic acid -- and for an open-chain compound. The results are shown in Figure 13. k is the rate constant for the bimolecular reaction and you see that the 6-thioctic acid has a rate constant of approximately 140; the six-membered ring only 4; the 8-methyl thioctic, with a methyl group on the end, actually oxidizes more rapidly than the thioctic itself; and the open-chain disulfide seems to be stable to persulfate, at least under the conditions that we did it. Undoubtedly it reacts with persulfate, but not appreciably in twenty-four hours. This represents a set of very rough measurements in fact at one temperature, and it wasn't even thermostatted. The only thermostating was the cell house of the Cary spectrograph. The temperature coefficients will have to be determined. A wider variety of structures should be studied, the pH dependence determined, and so on. None of these have been done and we hope to do that in the very near future. Here, again, we have very clear-cut evidence of the remarkably greater reactivity of the strained five-membered disulfide ring.

Photochemistry of the Cyclic Disulfides

Finally, I want to say something about the photochemistry of the disulfide. Since it absorbs in the visible, or on the edge of the visible, and since we believe that the absorption of light, in effect, opens the disulfide bond, or at least loosens it up markedly, we examined some of the photochemical reactions of the trimethylene disulfide. Figure 14 shows the result of photolysis of the disulfide in petroleum ether, in the presence of diphenylpicrylhydrazyl. Now diphenylpicrylhydrazyl is a stable free radical which presumably will catch any transient free radicals which would be formed in the photolysis of the disulfide. You will notice that it is only while the light is on in the presence of the disulfide that we get a fading of the picrylhydrazyl. This was done with a suitable set of filters so that the light that was absorbed was only the light absorbed by the disulfide and not by the picrylhydrazyl. This might be taken as evidence that the photo-excited state of the disulfide is a free radical. However, there is a catch to this, as we found later. The ordinary mercaptans will bleach picrylhydrazyl, perhaps not as rapidly as this, but we couldn't eliminate that possibility, even though in general in petroleum ether photolysis of the disulfide led to polymerization if there was no picrylhydrazyl present. This is an important observation which can be generalized -- that photolysis of the disulfide in neutral media, even hydroxylic media but in neutral solution and fairly concentrated (0.01 M or thereabouts) leads to polymerization. This was just another reason for supposing that the photolysis led to a diradical which then could polymerize by reaction with more disulfide.

The picrylhydrazyl was presumed to react with this diradical to prevent polymerization and bleach out picrylhydrazyl.

Now a similar set of reactions was the sensitized photooxidation of disulfide. This is really not anything specially limited to the disulfide, but I thought we would have a look at it in any case. It has interpretations possible other than the one it was designed to test, i.e. that light absorbed by the porphyrin could be transferred to the disulfide and bring it to a biradical form. However, the net reaction is the one in which the disulfide reacts with molecular oxygen, under the influence of light absorbed by a porphyrin:

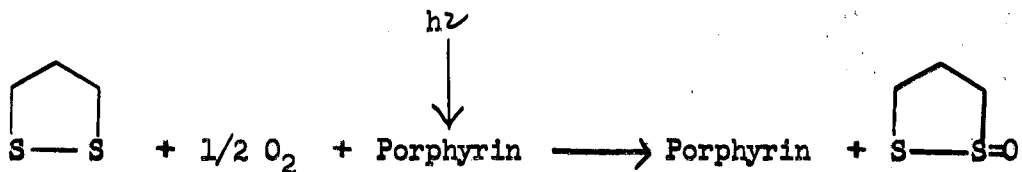

Light from the porphyrin will sensitize the photooxidation of the disulfide to the monoxide. This is demonstrated in Figures 15 and 16 which simply show that only when you have the porphyrin and disulfide in light do you get oxygen absorption. Figure 15 shows all the control experiments and there is only one that has all three reagents -- porphyrin, disulfide and light -- and that is the only one that shows oxygen absorption leading to photooxidation. Figure 16 shows the quantitative character of the reaction indicating that one atom of oxygen is absorbed per mole of disulfide. The solid horizontal line is the quantitative estimate which corresponds to the amount of oxygen which would be required to oxidize the disulfide to the monoxide. You see it's very nearly that, especially in curves 3 and 4, which are done at 4° , so that follow reactions do not take place.

Photolysis

The next observation is perhaps the most important of them all. This is the one which involves the photolysis of the disulfide in alcoholic solutions, or aqueous alcohol, in acid, basic and neutral media. The reason this experiment was done is as follows: We found, for example, that if you illuminate the disulfide in alcohol with near ultraviolet light, it would polymerize; it would turn milky and the polymer precipitates out. This was one of the big problems in the isolation, I might say, of the trimethylene disulfide. As soon as you began to concentrate the solutions, getting it beyond 0.01 M, it acted like a photographic plate; it seemed as if one quantum was almost enough to make the reaction mixture polymerize. With the addition of water to the alcohol solution of the trimethylene, you get an emulsion of the trimethylene disulfide in the aqueous alcohol, and each one of those little droplets is a concentrated solution. If one (?) quantum gets into that droplet, it polymerizes; this is very much like the silver grain of a photographic emulsion in that one respect. However, the next thing was to see if we could find out how the disulfide reacted with pyruvic acid -- either thermal or photochemical reactions. So we added pyruvic acid to the alcoholic solution and then illuminated it. There were no polymers formed. We thought that was fine -- presumably the free radicals reacted with the pyruvic acid. An examination of the phenomenon showed that this was really not the case at all, that any acid would prevent the polymerization. All that was required was that the solution be acidified to a pH around 1 or 2 with hydrochloric acid, then the polymerization was prevented, and something else happened. But what else happened was unknown to us and really occupied us for about a year -- to

try to determine what the reaction was in the photolysis of an acid solution of trimethylene disulfide. Since it was not polymerization, what was formed:

Figures 17 and 18 show the nature of the spectral changes during the photolysis. It is a rather complex series of arguments that is involved. Curve 1, Figure 17, shows the spectrum of the original trimethylene disulfide in acid alcohol, and curve 2 is after fifteen minutes of photolysis -- the disulfide is disappearing but no polymer is formed -- and after sixty minutes of photolysis the trimethylene disulfide is all gone. Figure 18 shows the absorption spectra carried out further into the ultraviolet. Curve 1, Figure 18, is the photolysis mixture itself right after photolysis, and curves 2, 3, 4 represent changes with time in the photolysis mixture. This set of absorption spectra is presented simply to demonstrate that whatever is primarily formed (curve 3) is unstable and is changing constantly with time (curve 4). Chemically we examined this photolysis mixture within a few hours after it was made, and we were able to establish five important facts about the photolysis mixture. (1) In the photolysis a single thiol group was formed per disulfide molecule disappearing. And that this was not the result of an average of dithiol with some non-thiol containing substance. (2) There was no dithiol in the photolysis solution -- no molecules with two SH's in them. (3) There was no acid consumed and no acid formed. In other words, there was no change in the hydrogen ion concentration, pH 2. The mercaptan concentration was finally determined by silver titration. When it was also attempted with iodine it was found that more iodine was absorbed than corresponded to the number of mercaptan groups. (4) So that there was something formed that was

susceptible to iodine oxidation other than mercaptans. This demonstrated the presence of some other reducing power in addition to the mercaptan itself which could reduce iodine. In addition to that, we were able to demonstrate the simultaneous presence of oxidizing power in this solution. The way we did that was to add to the photolysis solution some genuine trimethylene dithiol ($\text{HS-CH}_2\text{-CH}_2\text{-CH-SH}$). The photolysis solution converts it to the cyclic disulfide. (5) There was oxidizing power present. What that oxidizing power is, then, is really the problem we had from the start. These are some of the experimental facts -- not all -- which were available to us in order to decide what was happening in the photolysis of the trimethylene disulfide.

To make a long story short, the final conclusion to which we came was that the photolysis of the trimethylene disulfide in the presence of acid led to a very simple reaction, as a primary process,

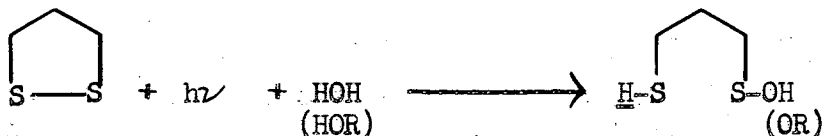

to form a thiol and a sulfenic acid (or ester). An examination of the literature on sulfenic acids is not very rewarding. As a matter of fact, there is only one claim for the preparation of a pure sulfenic acid and it is a very special case. It's an anthraquinone sulfenic acid and even that one is subject to some argument. I might say that here is a field of chemistry which is worthy of the best of us. The sulfenic acid might be viewed in another way, and as soon as you do that you begin to recognize some of the properties that are listed above. It can be viewed as the

sulfur analog of an alkyl hydroperoxide. When you do that, you see the possible reason for additional reducing power, besides the mercaptan, as well as the oxidizing power that is present.

Now, we may go a little further and try to estimate what the energy requirements of the primary reaction might be. We are breaking a sulfur-sulfur link -- one which we have studied a good deal now; we are breaking an O-H bond and forming an S-H bond also and an S-O bond. The net change in bond energies for the reaction would thus be

$$\Delta E = -E(\text{cyclic S-S}) - E(\text{H-O}) + E(\text{H-S}) + E(\text{S-O})$$

There are available fairly reliable kinetic values for E(H-O) (118 Kcals.) and E(S-H) (95 Kcals.), but such is not the case for E(S-S) and E(S-O). We are thus left with

$$\Delta E = -23 + [E(\text{S-O}) - E(\text{cyclic S-S})]$$

and we need only estimate the difference between the sulfenic acid S-O, and the cyclic disulfide bond energies. Since in whatever estimates are available, the peroxide O-O is always reported as 10-25 Kcals. less than the disulfide S-S, it is not unreasonable to suppose the difference in the bracket above will be negative or approach zero.

Although this involves much in the way of "guesstimation" it comes out that the energy requirement for the primary reaction might be expected to be of the order of +30 or +35 Kcals. This, may I remind you, corresponds to somewhat less than the energy of the quanta that are available at 7000 Å from chlorophyll, and even at 9000 Å from bacteriochlorophyll. So, we took the next step in our discussion, and suggested that the quantum

absorbed by chlorophyll (or also by bacteriochlorophyll in the cases where that is functioning) is handed on directly to the disulfide which then reacts with water, or some very close relative of it, to form a thiol-sulfenic acid. In doing this, it has utilized almost the entire energy available in the quantum. In doing it, it has also achieved what for years has been written in a formalistic way by most workers in photosynthesis as the primary action of the light, namely, the photolysis of water, sensitized by chlorophyll to give active hydrogen (in a bracket) and active oxygen (in a bracket). What we are suggesting now is that the

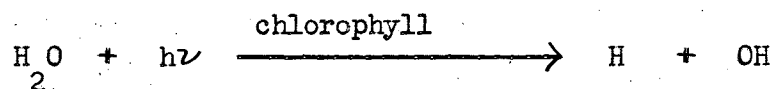

active hydrogen is the thiol and the active oxygen is specifically the sulfenic acid corresponding to the photolyzed thioctic acid.

The follow reactions from this, leading to substances which can reduce carbon dioxide, are straightforward. Thiol-sulfenic acid (I) being both oxidizing and reducing agent, can undergo a dismutation reaction via catalytic electron or hydrogen carriers leading to a dithiol plus an oxidized compound. Here, one can write a variety of compounds, I should like

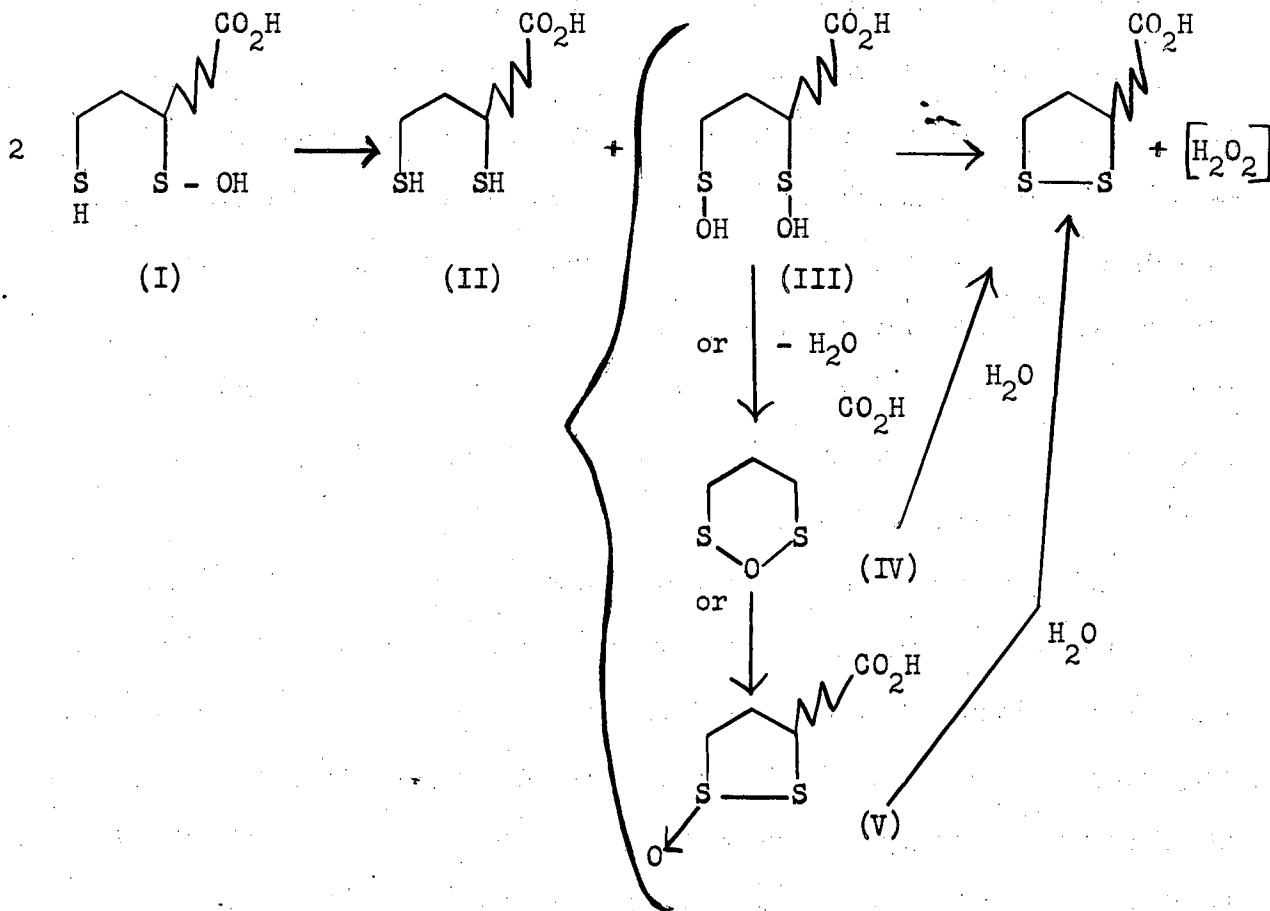

to write it as a sulfenic anhydride (IV) which could then do a number of things -- either rearrange to the monoxide (V) or react directly with water to form the disulfide and hydrogen peroxide. The hydrogen peroxide, then, if it is decomposed irreversibly (catalase (?)) would lead to molecular oxygen in a process requiring somewhat more than four quanta. If it is used as a reducing agent, which it could be, if the proper catalyst were found (perhaps excess catalase or copper enzyme with peroxide concentrations below $10^{-8} - 10^{-9}$ M) molecular oxygen might be produced in a process requiring somewhat more than three quanta. It has a pretty good reduction potential; as a matter of fact, it may have a good enough reduction potential to be used with an oxidizing agent of this sort (sul-

fenic acid). So much, then, for the model work on the disulfides.

Let us have one last fling at biology this afternoon and see if these ideas can be supported in any way by some direct biological experiments. You will remember that this whole notion arose from a biological experiment. There resulted, then, a series of physical and chemical studies on the disulfides, an examination of their peculiarities. Now we turn back again to see if we can't devise an experiment which would lend some support to the actual function of this sort of reaction in the primary quantum conversion act.

One might expect that if we could set up a system in which light absorbed by chlorophyll photolyzes water, evolves oxygen, and reduces something besides carbon dioxide, such as quinone, and if we could arrange the system so that the quantum conversion act is rate determining -- i.e. the fraction of absorbed quantum which is chemically effective is the bottleneck -- then by adding more quantum converting agent (acceptor) from outside you should be able to improve the quantum yield and the rate of oxygen evolution. Only under these limiting conditions can one expect such an effect. Only under the conditions in which the system is such that the rate-limiting step is the quantum conversion act, due to a shortage of quantum acceptors -- at present supposed to be the thioctic acid -- may we hope to observe an improvement in the quantum yield of oxygen production upon the addition of exogenous thioctic acid. We have fairly good evidence that the chlorophyll exists in a heterogeneous system in the plant in the form of a concentrated ordered arrangement in the plastids (grana). We are supposing that the thioctic acid which functions as the quantum converter is situated in or around this ordered array of

chlorophyll molecules. Direct analysis indicates that the chlorophyll/thioctic acid ratio in the chloroplasts is of the order of $1 - 5 \times 10^3$. Some interaction presumably exists between certain chlorophyll molecules and the thioctic acid and it may be quite small (< 1 Kcal.). Now a quantum may be absorbed by almost any one of the chlorophyll molecules in the granum, at which time it becomes available to most of the others in that array by a process like resonance transfer. The precise electronic state of the chlorophyll molecules at which this energy migration takes place is not crucial to the present discussion. At some time, presumably short with respect to the lifetime of the excited state within the granum, the quantum will find itself in a chlorophyll molecule adjacent to a thioctic acid molecule. It then makes the transition and since there is no π -bond system in the thioctic acid to hold it, reaction takes place with an OH group as proposed.

The transformation of electromagnetic energy from the excited state of chlorophyll into chemical energy in the excited state of the disulfide is the primary quantum conversion act, and if we can set it up so that this is the limiting thing, then by adding more quantum converter from outside and allowing it to be properly incorporated, we should improve the quantum yield of oxygen production. This we have succeeded in doing with Scenedesmus, reducing quinone and evolving oxygen. (12). By first treating the algae with 6-thioctic acid in air it was possible to increase the quantum yield for oxygen production with quinone reduction by about 50%, all other things being equal (Figure 19). The effect is specific for 6-thioctic acid. Unfortunately, this result does not constitute an unequivocal confirmation of the suggestion, since it is not

impossible to interpret the results in terms of a specific acceleration of dark hydrogen transfer reactions to the quinone. Nevertheless, it is still one more bit of supporting evidence. We hope that these suggestions may stimulate a search for more or less unequivocal experiments which will either confirm or deny the notion. For example, an attempt must be made to distinguish the oxygenated (sulfoxide (?)) from the non-oxygenated (disulfide and dithiol) forms of thiocctic acid in the plastids, and the effect of light and other controllable conditions on the relative amounts of these. Also, a search should be made for possible catalysts which might function in the dismutation reaction* of the thiol-sulfenic acid. The apparent concentration of both Cu and Fe in the chloroplasts, together with their known predisposition to function in hydrogen and oxygen activation reactions respectively, makes enzymes involving these elements very likely candidates for the job.

Irrespective of what the final outcome of such a search may be concerning this particular suggestion, it cannot fail to contribute to our basic understanding of this most important process.

(*) Reactions on page 25 of this manuscript.

References

1. Bassham, J. A. et al., J. Am. Chem. Soc. 76:1760, 1954.
2. Benson, A. A. et al., J. Biol. Chem. 196:703, 1952.
3. Dische, Z. Naturwiss. 26:252, 1938; Phosphorus Metabolism, Vol. I, pp. 171-199, 1951; Dische, A. and Pollaczek, paper presented at Second International Congress of Biochemistry, Paris, France, 1952.
4. Horecker, B. L. and Smyrniotis, P. Z., J. Am. Chem. Soc. 75:1009, 1953.
5. Racker, E. J., de la Haba, G. and Leder, I., Arch. Biochem. Biophys. 48:238, 1954.
6. Quayle, J. R., Fuller, R. C., Benson, A. A., and Calvin, M., J. Am. Chem. Soc., In press.
7. Calvin, M. and Massini, P., Experientia, 8:455, 1952.
8. Brockman, J. A., Jr., et al., J. Am. Chem. Soc. 74:1868, 1952.
9. Waddington, E. et al., J. Am. Chem. Soc. 72:2424, 1950; ibid. 74:2478, 1952.
10. Yakel, H. L. and Hughes, E. W., J. Am. Chem. Soc. 74:6302, 1952.
11. Pauling, L., Proc. Nat. Acad. Sci. 35:495, 1949.
12. Bradley, D. F. and Calvin, M., Arch. Biochem. Biophys., In press.

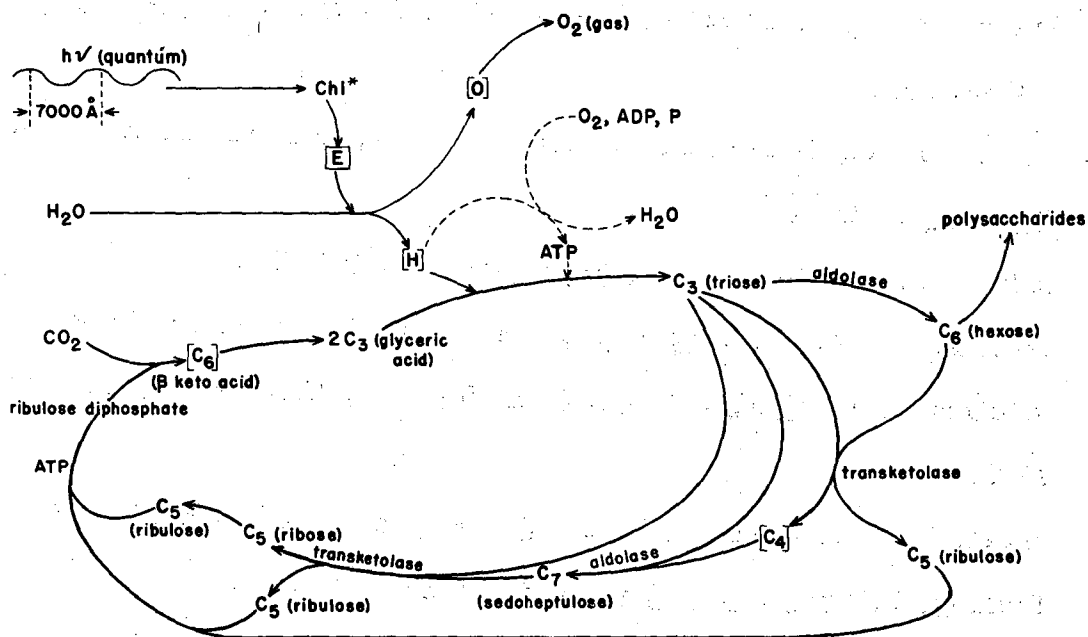

PROPOSED CYCLE FOR CARBON REDUCTION
IN PHOTOSYNTHESIS

MU-6600

Fig. 1

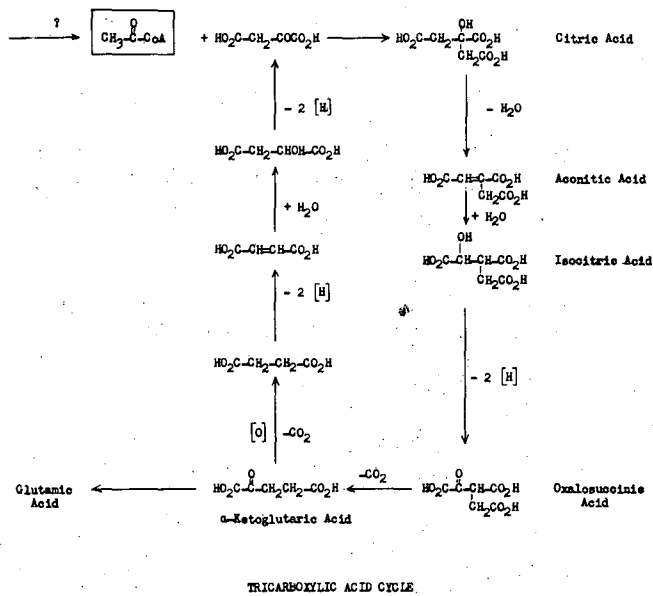

Fig. 2

(correct fig)

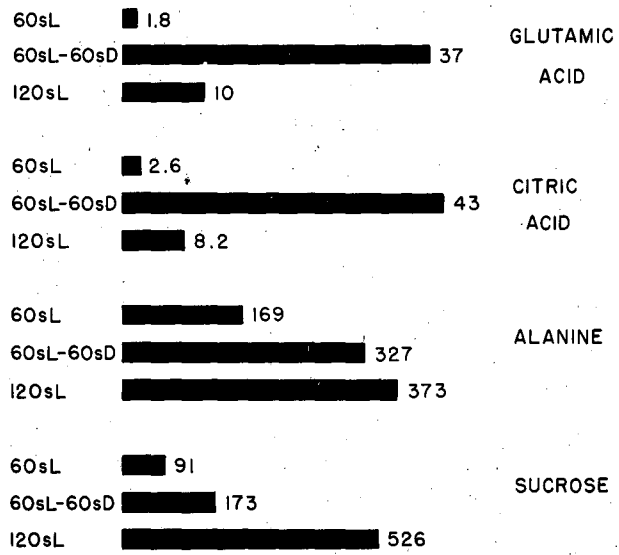
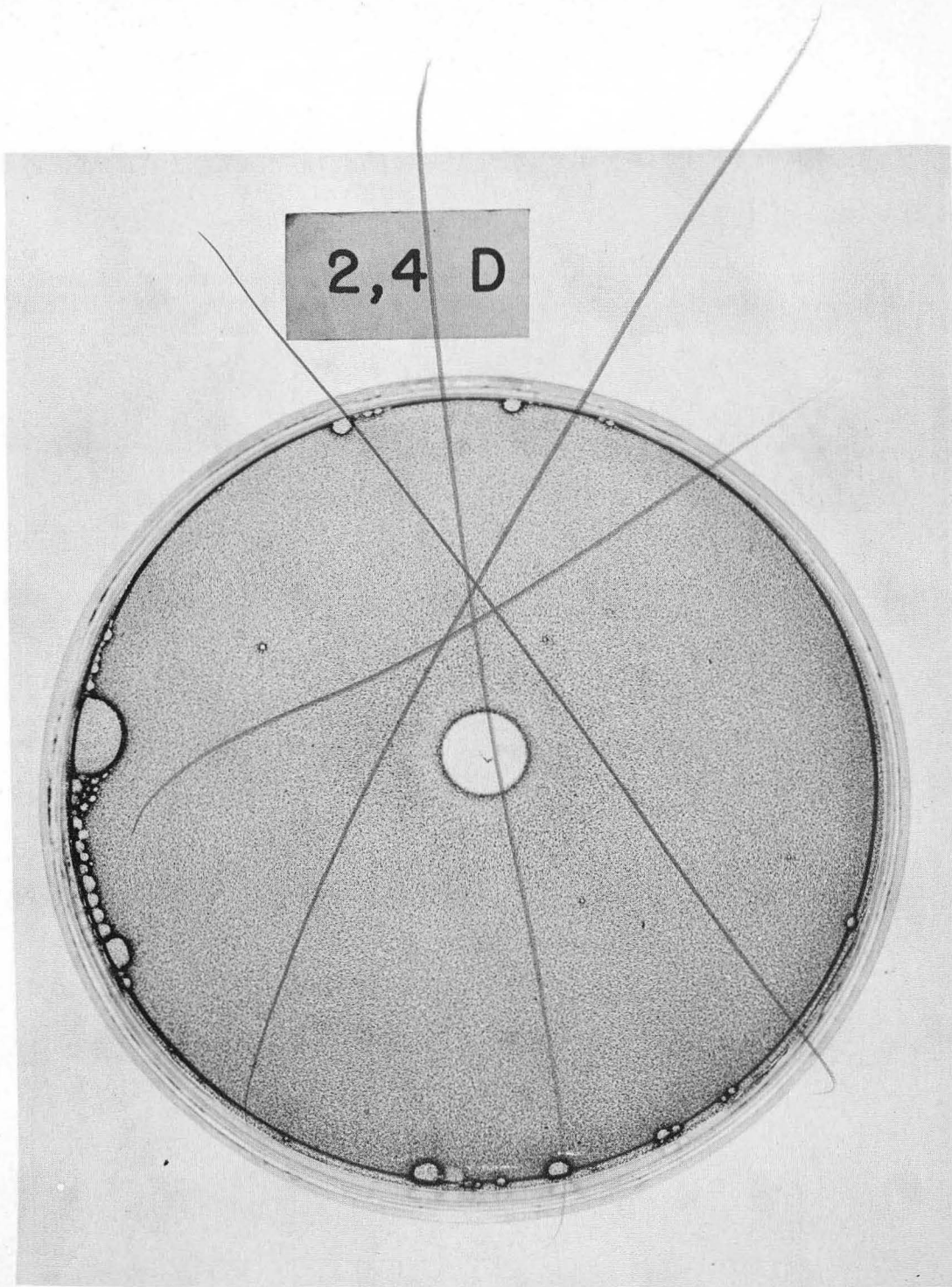

Fig. 3



ZN-993

Fig. 2

obsolete

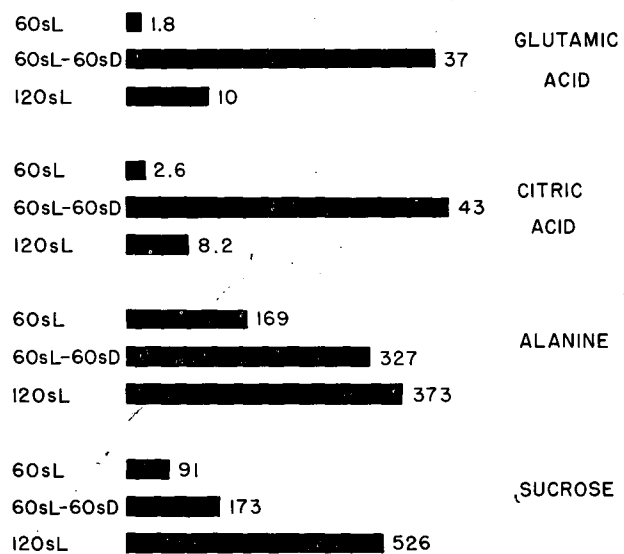

Fig. 3

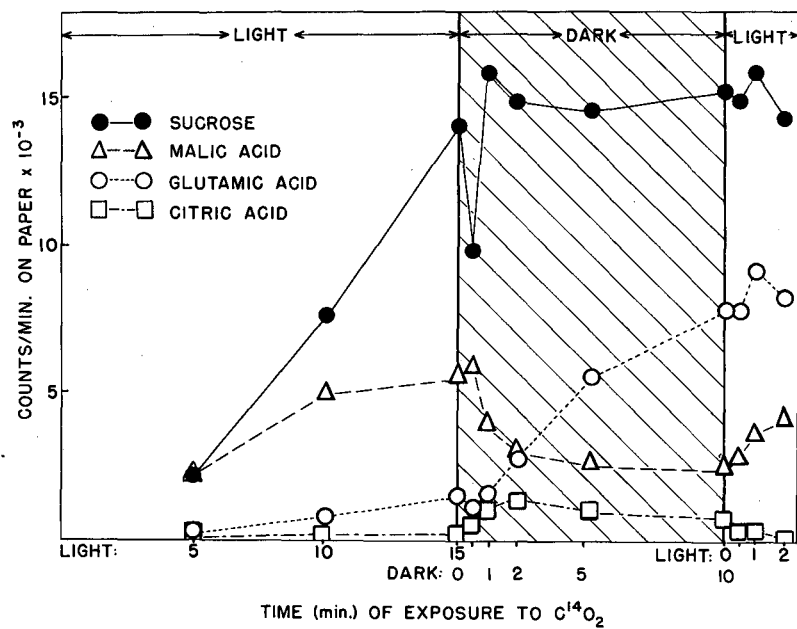

Fig. 4

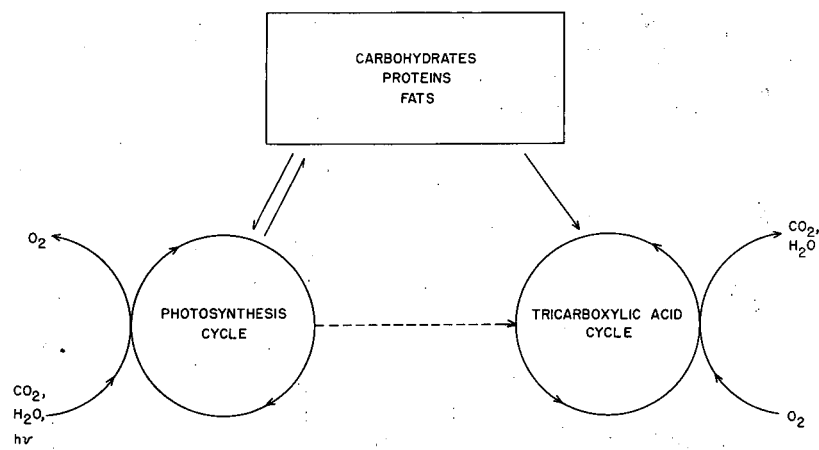

Fig. 5

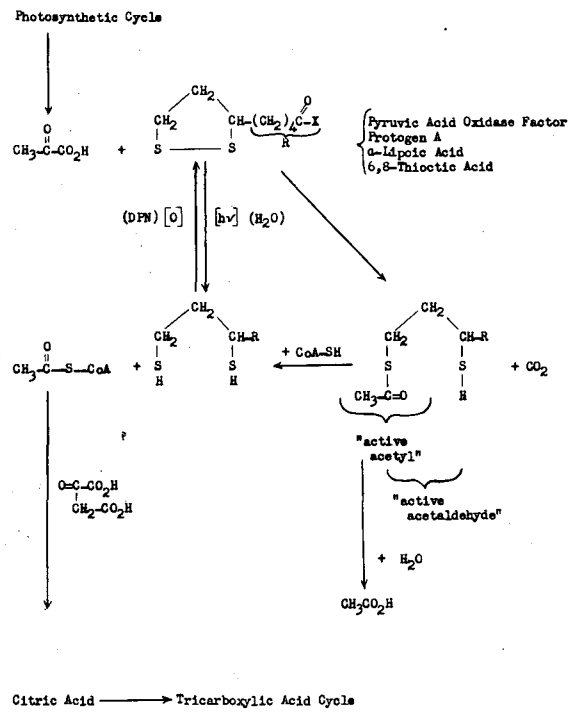
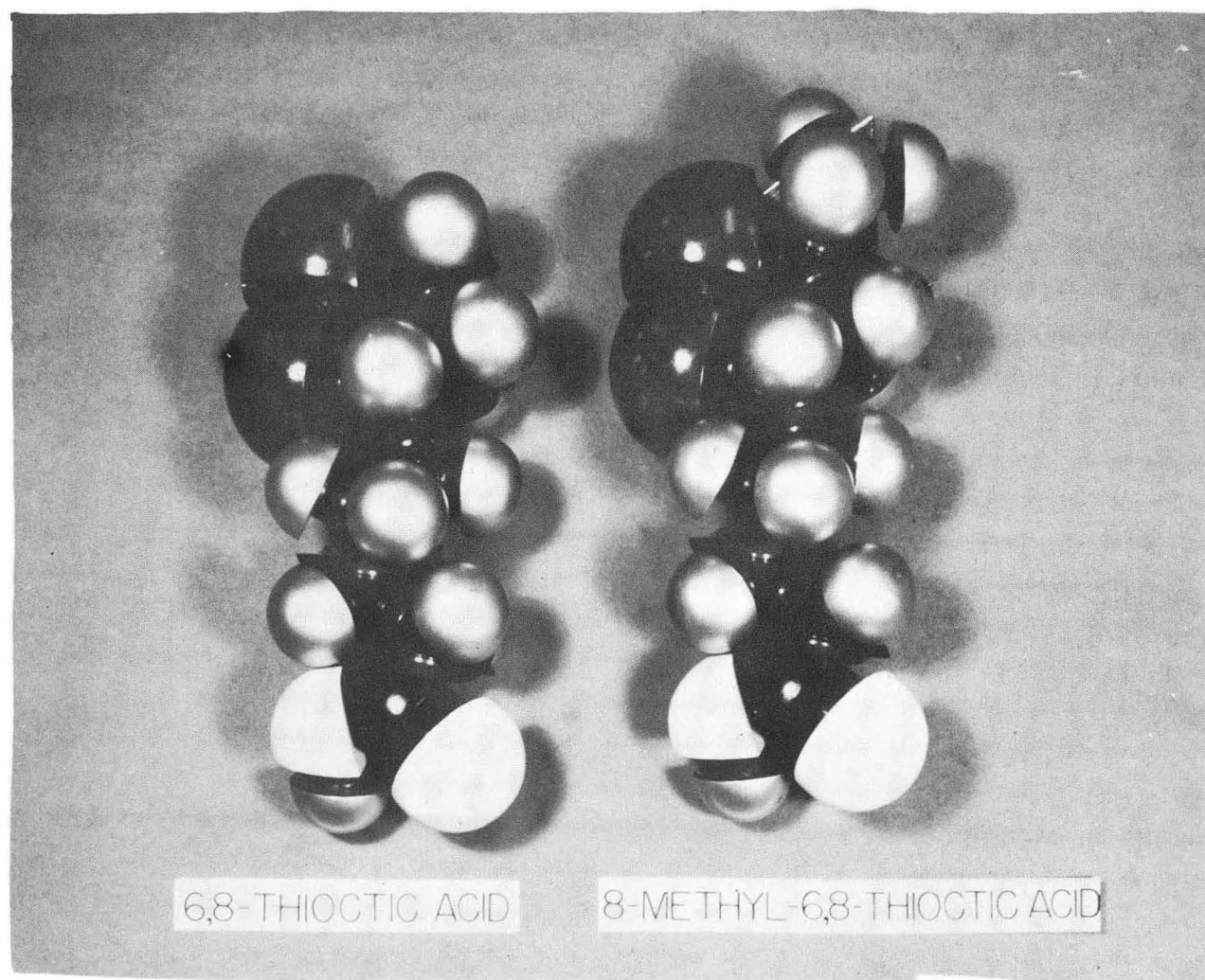

Fig. 6



ZN-995

Fig. 7

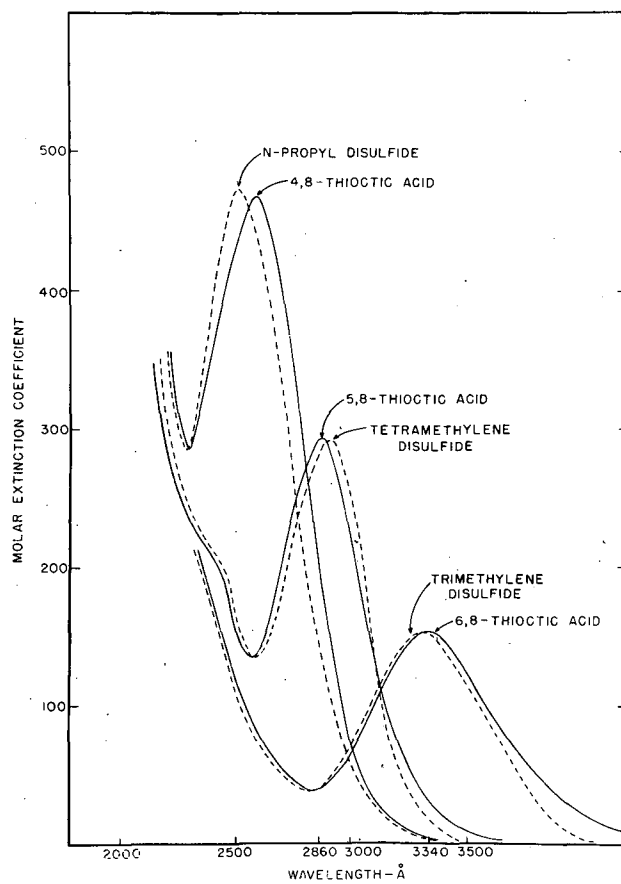

Fig. 8

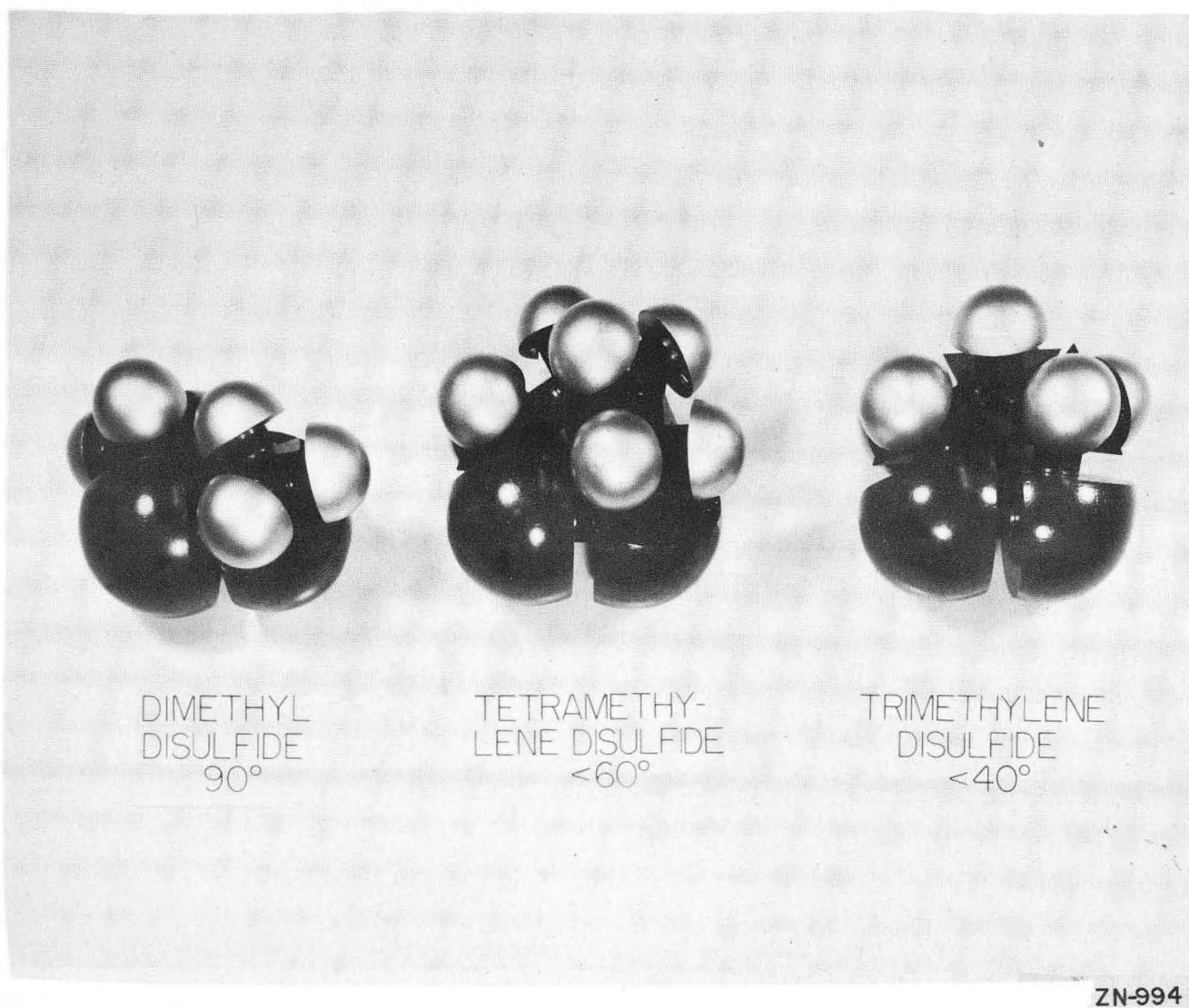
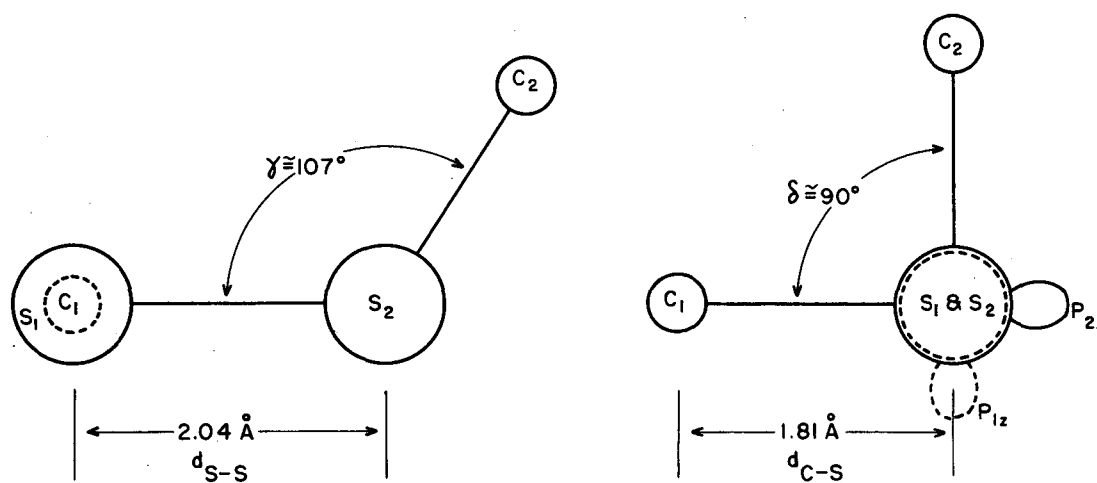

Fig. 9



GEOMETRY OF THE C-S-S-C SYSTEM

MU-6877

Fig. 10

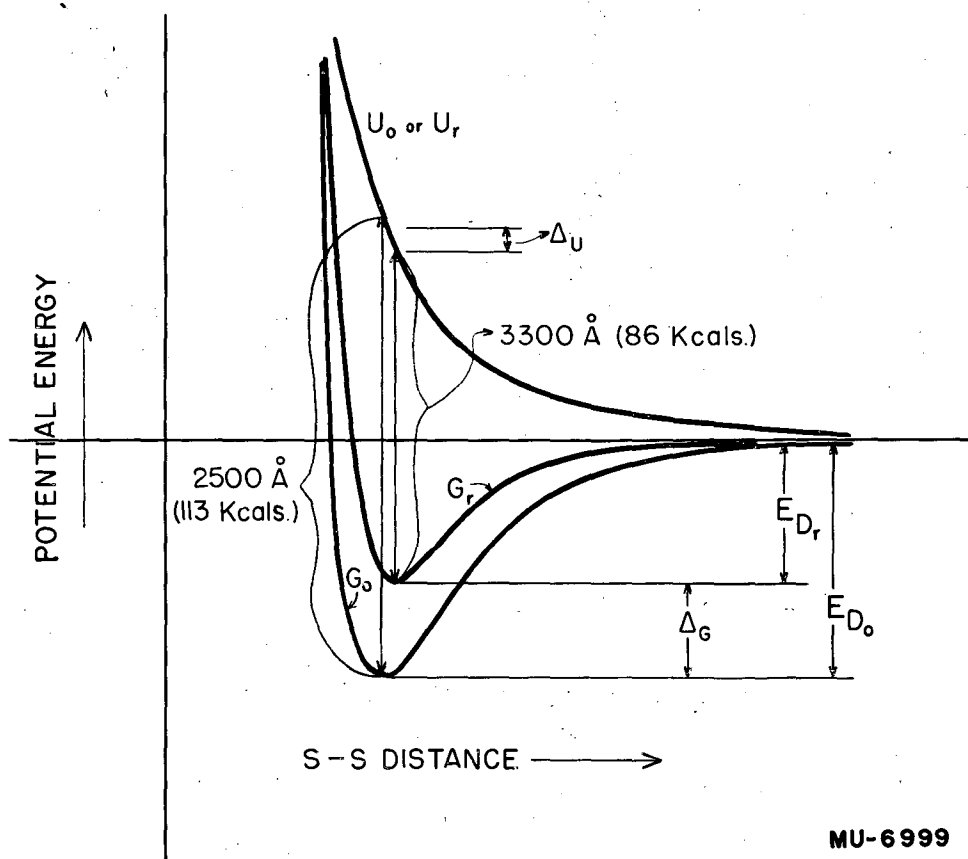

MU-6999

Fig. 11

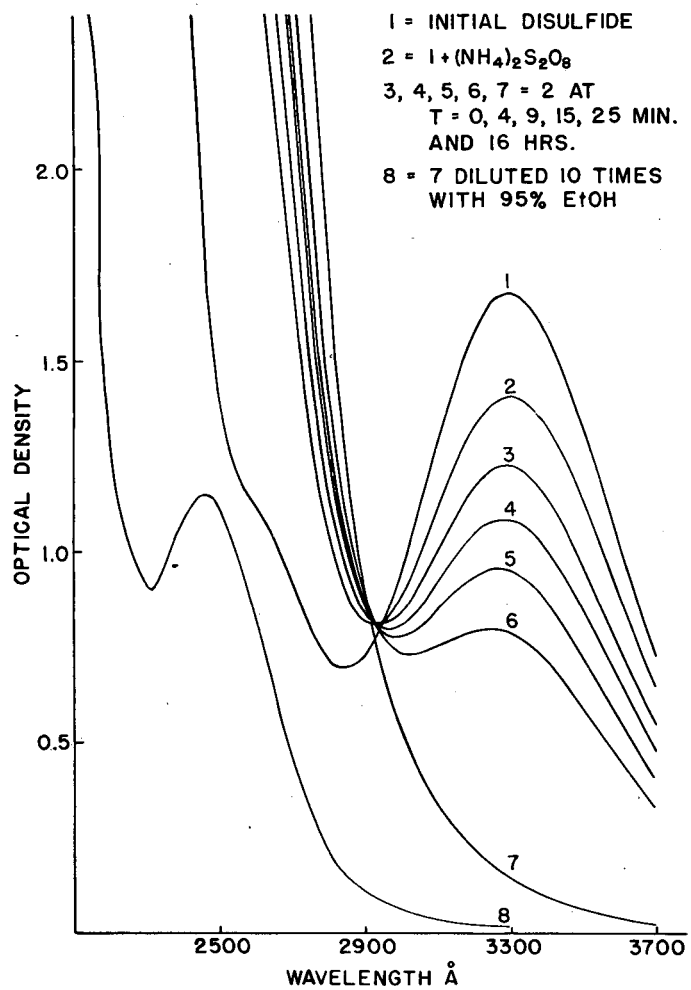

OXIDATION OF TRIMETHYLENE DISULFIDE BY AMMONIUM PERSULFATE

MU-6990

Fig. 12

OXIDATION OF $\begin{array}{c} \text{R} \quad \text{R} \\ | \quad | \\ \text{S}-\text{S} \end{array}$ BY $(\text{NH}_4)_2\text{S}_2\text{O}_8$ TO $\boxed{\text{S}-\text{S}} = 0$
 AT -25°C . IN H_2O ($.01 \text{ N H}^+$)

	$k(\text{m}^{-1} \text{ l min}^{-1})$
6,8-thioctic	141
5,8-thioctic	4.2
8-methyl-6,8-thioctic	220
Open chain S-S	0

$$-\frac{d(\text{S-S})}{dt} = k [\text{S-S}] [\text{S}_2\text{O}_8^{=}]$$

MU-7300

Fig. 13

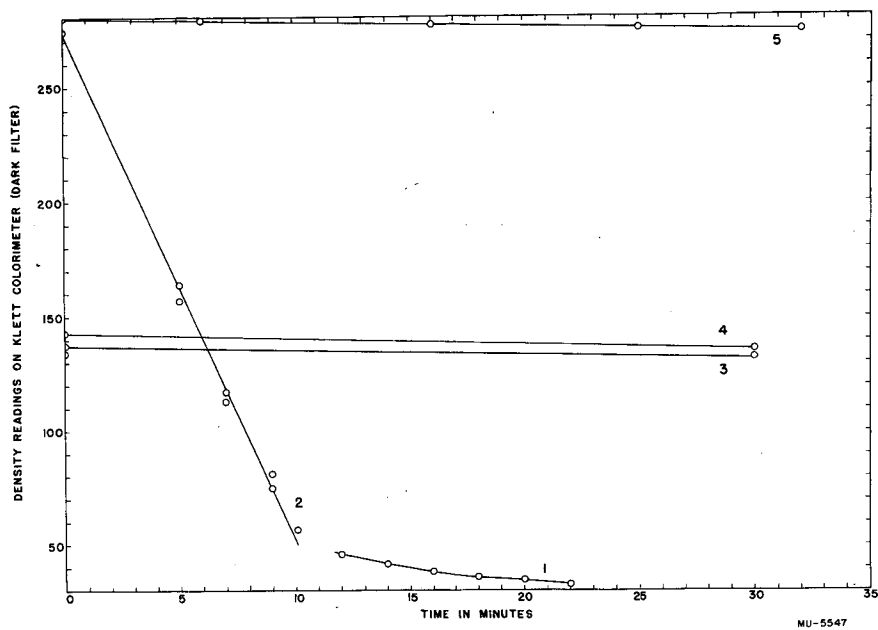

PHOTOLYSIS OF DIPHENYL PICRYL HYDRAZYL IN THE PRESENCE OF TRIMETHYLENE DISULFIDE

1. IN DARK AFTER ILLUMINATION
2. PICRYL HYDRAZYL + c1ccccc1 IN LIGHT
3. PICRYL HYDRAZYL IN DARK
4. PICRYL HYDRAZYL IN LIGHT
5. PICRYL HYDRAZYL + c1ccccc1 IN DARK

Fig. 14

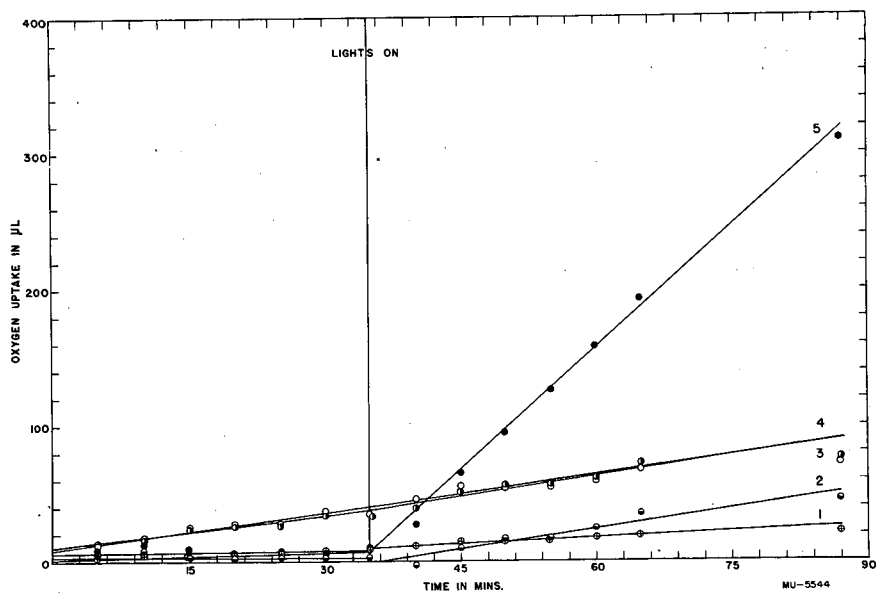

PHOTO-OXIDATION OF C1=CC=C(C=C1)S(=O)(=O)S1=CC=CC=C1 CATALYZED BY ZINC TETRAPHENYL PORPHIN

- 1. C1=CC=C(C=C1)S(=O)(=O)S1=CC=CC=C1 + P.E.
- 2. PORPHIN + P.E.
- 3. PORPHIN + Bz
- 4. C1=CC=C(C=C1)S(=O)(=O)S1=CC=CC=C1 + Bz
- 5. PORPHIN + C1=CC=C(C=C1)S(=O)(=O)S1=CC=CC=C1 + Bz + P.E.

Fig. 15

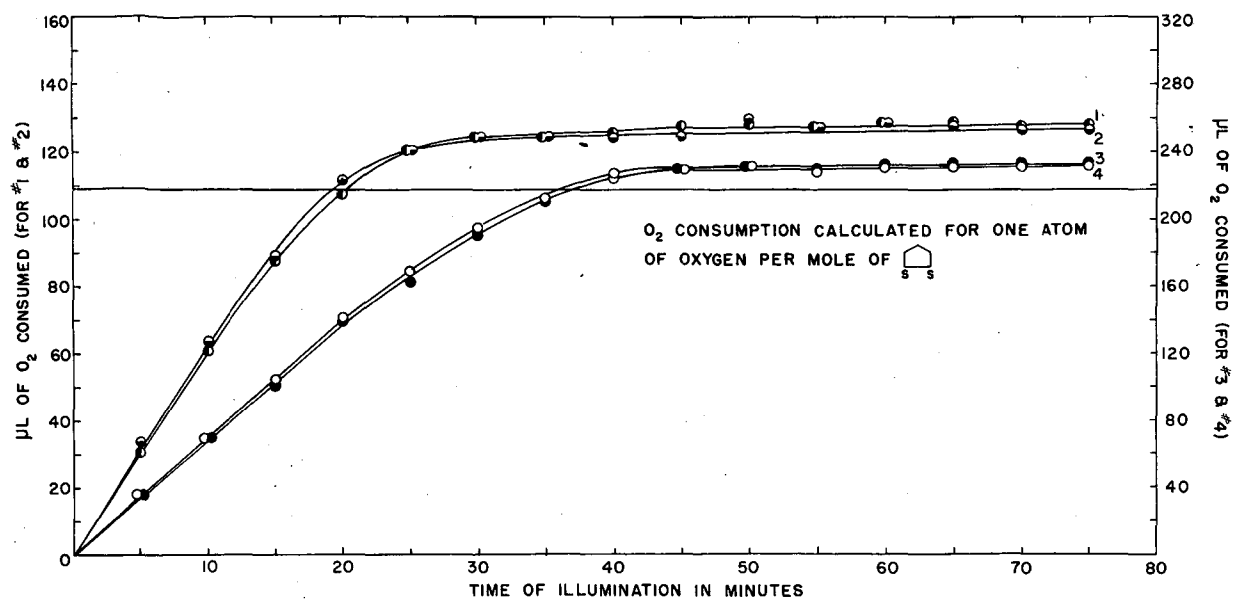
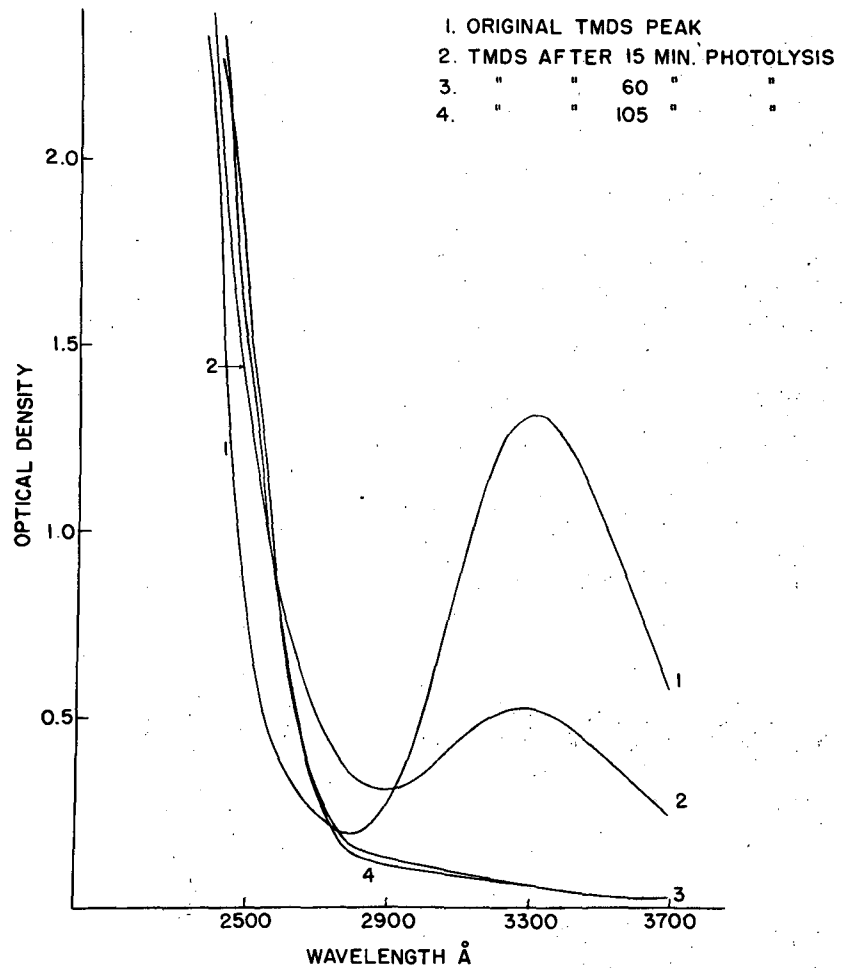

PHOTO-OXIDATION OF S-S CATALYZED BY ZINC TETRAPHENYL PORPHIN

MU-5543

Fig. 16



MU-6991

Fig. 17

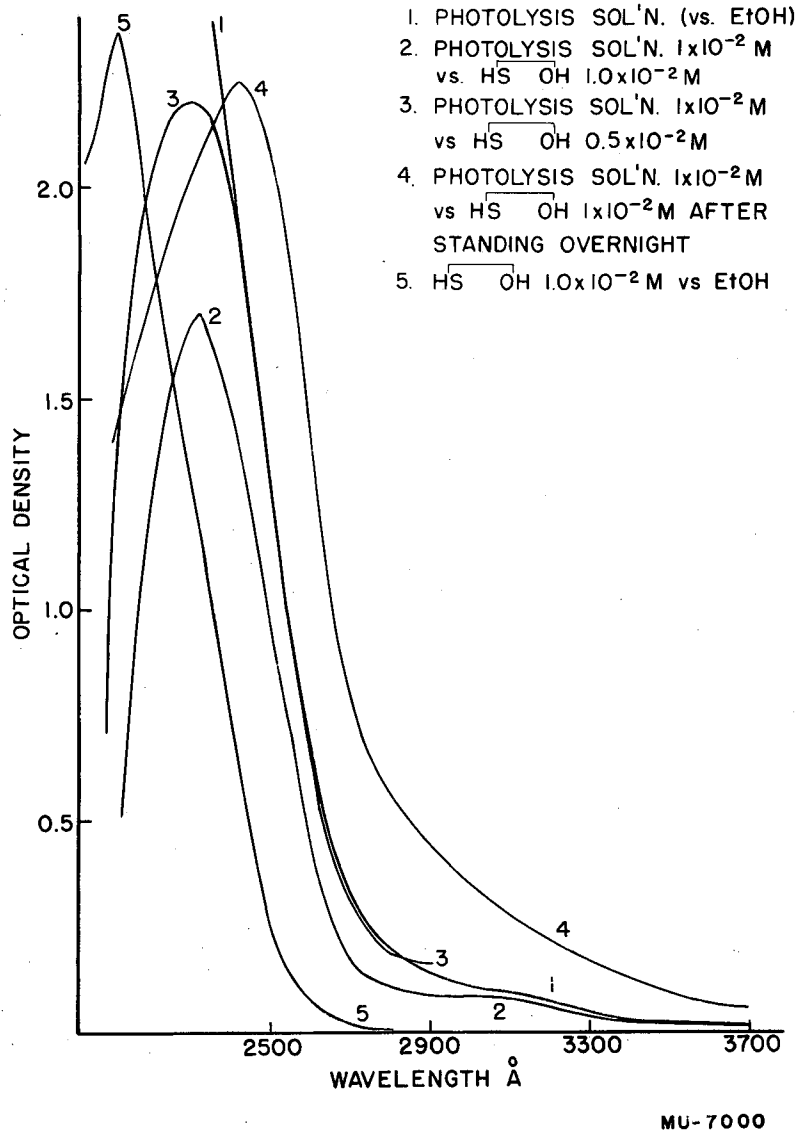

Fig. 18

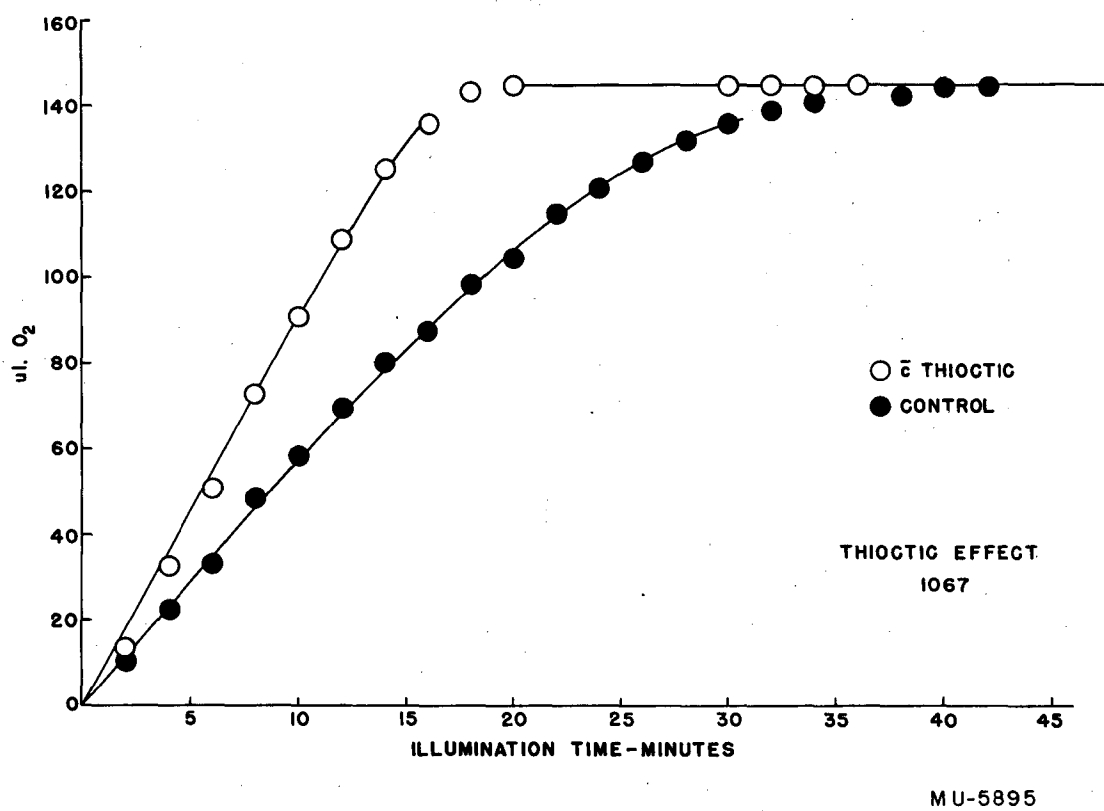

Fig. 19