

# Lawrence Berkeley National Laboratory

## LBL Publications

### Title

A Building Life-Cycle Information System for Tracking Building Performance Metrics

### Permalink

<https://escholarship.org/uc/item/0rn7j5x8>

### Authors

Hitchcock, R J

Piette, M A

Selkowitz, S E

### Publication Date

1999-04-01



# ERNEST ORLANDO LAWRENCE BERKELEY NATIONAL LABORATORY

## A Building Life-Cycle Information System for Tracking Building Performance Metrics

R.J. Hitchcock, M.A. Piette, and S.E. Selkowitz

**Environmental Energy  
Technologies Division**

April 1999

To be presented at the  
*Eighth International Conference  
on Durability of Building  
Materials and Components,*  
May 30-June 3, 1999,  
Vancouver, BC,  
and to be published in  
the Proceedings

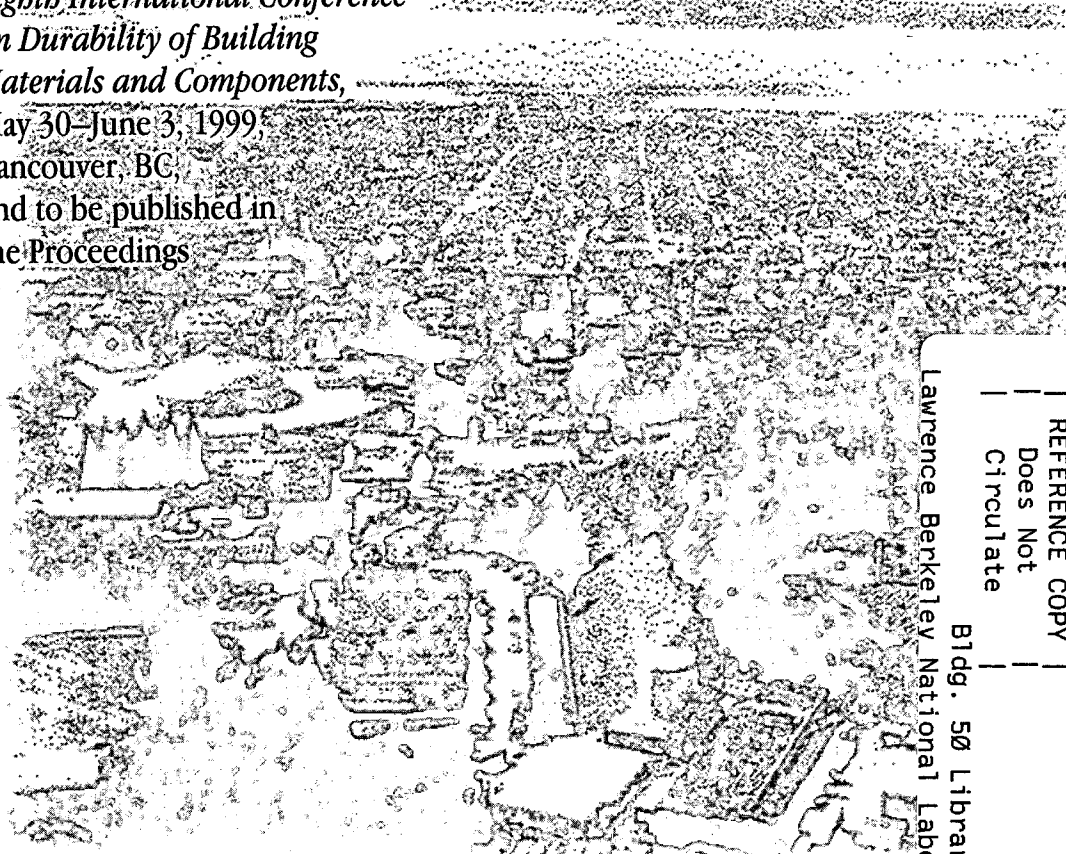

Lawrence Berkeley National Laboratory  
Bldg. 50 Library - Ref.  
| REFERENCE COPY |  
| Does Not |  
| Circulate |  
Copy 1

## **DISCLAIMER**

This document was prepared as an account of work sponsored by the United States Government. While this document is believed to contain correct information, neither the United States Government nor any agency thereof, nor the Regents of the University of California, nor any of their employees, makes any warranty, express or implied, or assumes any legal responsibility for the accuracy, completeness, or usefulness of any information, apparatus, product, or process disclosed, or represents that its use would not infringe privately owned rights. Reference herein to any specific commercial product, process, or service by its trade name, trademark, manufacturer, or otherwise, does not necessarily constitute or imply its endorsement, recommendation, or favoring by the United States Government or any agency thereof, or the Regents of the University of California. The views and opinions of authors expressed herein do not necessarily state or reflect those of the United States Government or any agency thereof or the Regents of the University of California.

Proceedings of the 8<sup>th</sup> International Conference on Durability of Building Materials and Components, May 30 - June 3, 1999, Vancouver, BC

## **A Building Life-Cycle Information System For Tracking Building Performance Metrics**

R. J. Hitchcock, M. A. Piette, and S. E. Selkowitz

Commercial Building Systems  
Building Technologies Department  
Environmental Energy Technologies Division  
Ernest Orlando Lawrence Berkeley National Laboratory  
University of California  
1 Cyclotron Road  
Berkeley, California

April 1999

This work was supported by the Laboratory Directed Research and Development Funds of Lawrence Berkeley National Laboratory and by the U.S. Environmental Protection Agency, Office of Atmospheric Programs, Atmospheric Pollution Prevention Division; through the U.S. Department of Energy under Contract No. DE-AC03-76SF00098.

# **A Building Life-Cycle Information System For Tracking Building Performance Metrics**

R. J. Hitchcock, M. A. Piette, and S. E. Selkowitz

## **Abstract**

Buildings often do not perform as well in practice as expected during pre-design planning, nor as intended at the design stage. While this statement is generally considered to be true, it is difficult to quantify the impacts and long-term economic implications of a building in which performance does not meet expectations. This leads to a building process that is devoid of quantitative feedback that could be used to detect and correct problems both in an individual building and in the building process itself. One key element in this situation is the lack of a standardized method for documenting and communicating information about the intended performance of a building. This paper describes the Building Life-cycle Information System (BLISS); designed to manage a wide range of building related information across the life cycle of a building project. BLISS is based on the Industry Foundation Classes (IFC) developed by the International Alliance for Interoperability. A BLISS extension to the IFC that adds classes for building performance metrics is described. Metracker, a prototype tool for tracking performance metrics across the building life cycle, is presented.

## **Introduction**

Buildings often do not perform as well in practice as expected during pre-design planning, nor as intended at the design stage, nor even as measured during commissioning and maintenance operations. While this statement is generally considered to be true, it is difficult to quantify the impacts and long-term economic implications of a building in which performance does not meet expectations. This leads to a building process that is devoid of quantitative feedback that could be used to detect and correct problems both in an individual building and in the building process itself.

A key element in this situation is the lack of a standardized method for documenting and communicating information about the intended and actual performance of a building. This deficiency leads to several shortcomings in the life-cycle management of building information. Planners have no means of clearly specifying their expectations. Designers cannot concisely document their design intent. Commissioning personnel have no standardized method for documenting the results of performance testing. Post-occupancy building performance cannot readily be compared to expectations in an attempt to evaluate and improve design and operation decisions. Lastly, without quantification of the magnitude of performance problems it is difficult to motivate building process participants to alter their current practice.

This paper describes the Building Life-cycle Information System (BLISS); designed to manage a wide range of building related information across the life cycle of a building project. An initial implementation of BLISS is based on the International Alliance for Interoperability's (IAI) Industry Foundation Classes (IFC), an evolving data model under development by a variety of architectural, engineering, and construction (AEC) industry firms and organizations (IAI 1998). A BLISS extension to the IFC that adds classes for building performance metrics is

described. Metracker, a prototype tool for tracking performance metrics across the building life cycle, developed to address the shortcomings identified above, is presented.

### **A Building Life-Cycle Information System (BLISS)**

The overall concept behind a building life-cycle information system is to provide a distributed computing environment for managing, archiving, and providing access to the wide variety of data that are generated across the complete life cycle of a building project. One goal of providing such a system is to initiate the industry-wide development and standardization of an interoperable set of tools to address a variety of information transfer problems in the building life cycle. Each individual tool must be tailored to respond to the needs of project participants within a specific phase of the project life cycle. Yet the data used and produced by each of these tools must also be standardized to allow interconnection through a common information infrastructure.

Figure 1 shows a high-level representation of the key elements of our Building Life-cycle Information System (BLISS). One element of such an information system is a detailed data model describing the physical components and systems contained within a building design, such as walls, windows, spaces, and HVAC and lighting equipment. This type of data model is commonly referred to as a product model. We believe that in addition to a product model, the system must also contain a clear and concise representation of the performance objectives for a building project, discussed in more detail in the following section. Furthermore, by capturing the relationship between performance objectives and the product components selected to achieve these objectives, we have a means of documenting the rationale behind design decisions. Within BLISS, this combination of informational elements is maintained for various building versions as the project moves through its life cycle. This provides an historical record of previous versions along with the current version.

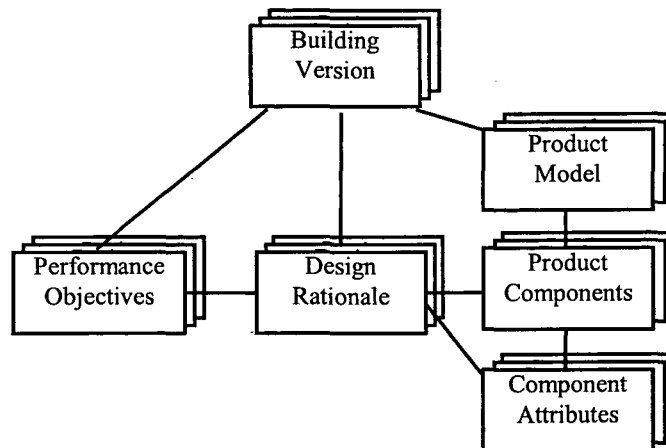

**Fig. 1: Key elements of a building life-cycle information system.**

#### *Performance Objectives and Metrics*

A building project begins with a consideration of the various performance objectives of interest to building stakeholders. While primary attention is generally given to space requirements and construction costs, a wide spectrum of objectives may be at least informally

considered at this stage, including: life-cycle economics; energy-efficiency; environmental impact; occupant health, comfort and productivity; and building functionality, adaptability, durability, and sustainability. The process of identifying the objectives for a given building project is often referred to as programming. The outcome of programming is most commonly recorded in text that becomes part of design and construction documentation. This documentation may be frequently referenced during design, and occasionally referenced during construction, but then most often collects dust from that time forward.

Performance metrics are designed to explicitly represent project objectives, using quantitative criteria, in a dynamic, structured format that provides value across the life cycle of a building project. One or more metrics may be defined for any given performance objective that building process participants (e.g., owners, designers, operators, occupants) wish to specify and track. A guiding principle in defining a performance metric is to identify a critical variable that measures, reflects, or significantly influences a particular performance objective. To be useful across the building project life cycle, each metric must also be capable of being either predicted or measured at various stages of the project so that the achievement of each objective can be evaluated.

In most instances, a high-level performance objective will need to be delineated by multiple metrics that influence its overall satisfaction. This delineation can be organized hierarchically. The hierarchy in Figure 2 shows one possible subset of performance metrics that could be used to specify, track, and maintain energy-efficiency in a building. Note that each performance metric is not necessarily a simple arithmetic sum of its constituent metrics. The hierarchical organization logically groups metrics that are important to track because of their impact on their parent metric. For example, one component of whole-building energy performance is the cooling system energy use intensity (Cooling EUI) which in turn is influenced by chiller and cooling tower efficiencies and building cooling load, among other possible elements.

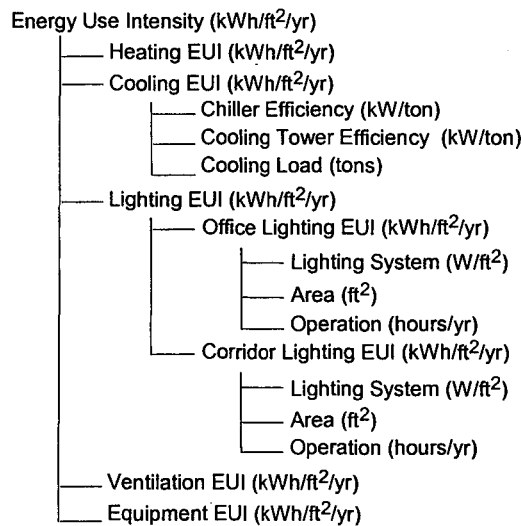

**Fig. 2: Performance metric breakdown for energy use intensity.**

Performance metrics come in a variety of forms for which there is presently little standardization. For example, chiller efficiency can be specified in numerous ways including: a

single value parameter (e.g., coefficient of performance (COP) or integrated part load value (IPLV)), multiple data points representing a two-dimensional part load curve for specific operating conditions or a three-dimensional part load surface across the full operating regime, or a mathematical curve or surface function representing these same data. Moreover, the preferred method for documenting a performance metric may change over the life cycle of a project. Following the chiller efficiency example, pre-design planning might specify a desired chiller IPLV. Detailed design simulation might employ a mathematical representation (e.g., a curve fit) of the performance of the selected chiller, based on manufacturer specifications. Commissioning and O&M measurements might subsequently collect multiple time series data points during the chiller's actual operation. The specification of a performance metric must therefore be flexible enough to accommodate this variety of forms.

Our data definition for a performance metric includes the following parameters: name, specifier, date of specification, description, benchmark value and source, and assessment value(s) and source. The metric *name* is a text identifier which we intend in the future to supplement with a standardized code for predefined sets of performance metrics. These sets will be drawn from work in this area by the industry associations such as the Green Building Challenge (GBC), the American Society of Heating, Refrigerating, and Air-conditioning Engineers (ASHRAE), and the Illuminating Engineering Society (IES) (Larsson 1993; ASHRAE/IES 1989). We also intend to solicit input from a variety of industry participants in generating these predefined metrics. The *specifier* and *date of specification* document the building process participant concerned with each building performance objective. The *benchmark value* documents the intended level of performance. The *benchmark source* archives the origin of the benchmark value (e.g., code, standard, simulation, manufacturer data). One or more *assessment values* record the performance of a building design, or an operating building, over time. The *assessment source* indicates the means by which a performance level has been assessed (e.g., simulation, measurement, estimation).

Sets of both benchmark and assessment values are archived for each performance metric over the life cycle of a building project. There may be an initial benchmark value established in pre-design planning, updated benchmark values and predicted assessment values determined during design, short-term measurements from commissioning, and long-term monitored values.

#### *A Scenario for BLISS*

One of the challenges in the development and use of tools to archive performance metrics is that the metrics cannot stand on their own. They are linked, as discussed above, to design details and operating conditions that generate the specified, predicted or measured performance that is to be evaluated against a benchmark. Thus, the concept in BLISS is to ensure that there is a product model of the building that can be used to predict design performance through the use of simulation tools.

Figure 3 outlines a possible scenario for the use of performance metrics and a building life-cycle information system. The scenario begins in the programming phase (Step 1), where a set of performance metrics are selected and recorded in BLISS to represent building performance objectives. In Step 2, computer aided design tools are used for the architectural and engineering design of the building, and the resulting data are used as input to various simulation tools to predict the performance of the current design for evaluation against the desired performance. Results from the final design simulations are summarized in an updated set of performance



metrics, which establish a set of benchmarks for use in commissioning. Modifications to the building design due to construction changes, or to the building operation due to occupancy or use changes, must be consistently documented in the product model to provide as-built information. Note that the impacts of these changes can be evaluated more easily and comprehensively given the data contained in BLISS. As installation of each building system is completed, commissioning tests are conducted to determine if the design intent was met (Step 3). Also at this stage, in-situ test results are used to re-calibrate simulation models and update the appropriate performance metrics. In this manner consistent up-to-date documentation of both the building and its expected performance is maintained for use during building occupancy.

In Step 4 the building automation system (BAS) is used to continuously monitor the building and provide diagnostics with real-time simulation that checks actual operation against current performance benchmarks. These data are also used in Step 5 to track operations and maintenance (O&M) actions. One benefit of such integrated information systems is that one can readily identify the energy impact of O&M actions. For example, when the chillers are cleaned, the efficiency is improved and the new energy performance readily measured. O&M can therefore be optimized. The system is also linked to a retrofit simulation tool that allows the facility manager to explore the energy savings from possible major or minor system changes (Step 6). Each step involves the generation of metrics, which are archived and accessed in the common database format. The facility manager has a clear record of the design, as-built, and as-operated equipment, along with the performance of the building. Furthermore, the history of building design decisions and the resulting performance can be used to undertake post-occupancy evaluation of the building in order to better inform future designs.

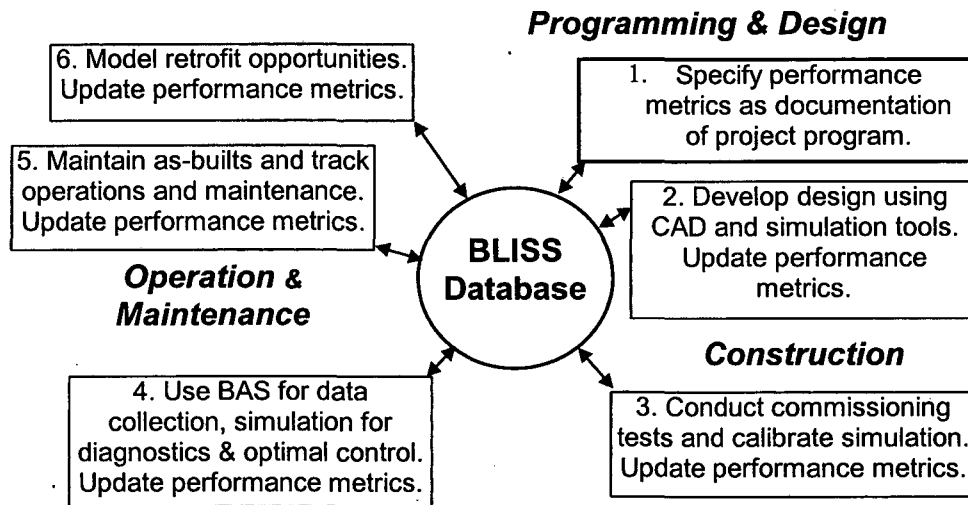

Fig. 3: Use of performance metrics through the building life cycle.

### A Prototype Tool for Tracking Performance Metrics (Metracker)

We are developing a prototype implementation of a performance metric tracking tool, called Metracker, using the BLISS concepts described above. Metracker consists of a standardized data model and data exchange mechanism, and a user interface.

The Metracker prototype is built upon the IAI Industry Foundation Classes Release 1.5.1 (IFC1.5.1) data model extended with our definition of building performance metrics. The performance metric extensions to the IFC1.5.1 data model conform to IAI prescribed methods, enabling IFC-compliant tools to exchange data with the prototype. The data exchange mechanism uses the IFC method of writing and reading STEP Express files, an international standard for the exchange of product data. We are working to incorporate the performance metric data classes in future releases of the IFC. In the meantime, only those tools that are cognizant of the performance metric extensions will be able to interpret these data. However, any IFC-compliant tool will be able to read and pass on the data intact to other tools.

The user interface for Metracker focuses attention on the specification, tracking, and visualization of performance metrics. This is accomplished through a data browser that displays the organization and details of a BLISS archive, and graphical visualization of performance metric data comparing intended and actual performance across the building life cycle. Figure 4 shows an example of the Metracker data browser interface.

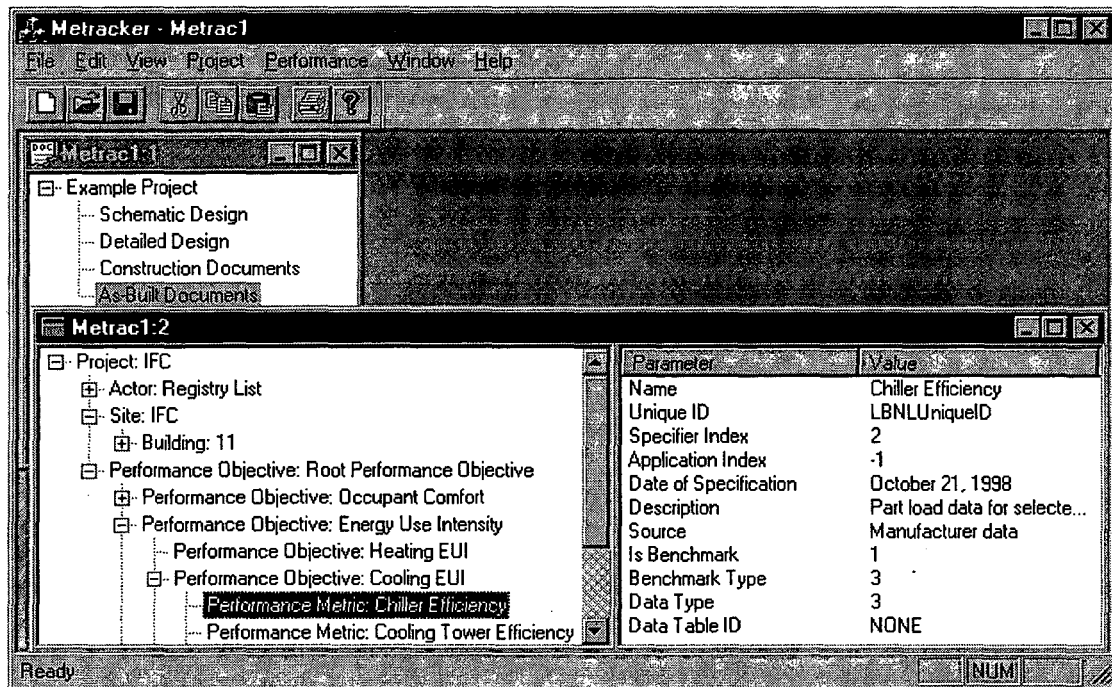

Fig. 4: Metracker data browser.

The smaller window in the upper left lists multiple building versions that have been archived in a hypothetical BLISS project named Example Project. The left pane of the lower window displays a hierarchical tree of the various objects (e.g., Actor, Site, Building, Performance Objective, and Performance Metric) that have been instantiated as part of the selected building version (As-Built Documents as shown here). The right pane of the lower window displays the parameters of the selected object and their values.

In this figure, the parameters for the performance metric Chiller Efficiency are shown. In this instance, this is a metric benchmark that will contain manufacturer data for the part load

efficiency of a chiller. The zero-based index values for several enumerated types are shown here instead of more descriptive values. These include Specifier and Application indexes which denote the actor and application that created this particular performance metric. The details of each actor and application are contained in separate lists within the archive. Also, Benchmark and Data Type indexes identify the type of benchmark and the type of data defined for this metric. We are still in the process of determining the most appropriate types for these metric parameters. As of this writing, benchmark types include minimum, maximum, range, target with tolerance, and distribution. Data types presently include scalar, vector, two-dimensional matrix, three-dimensional matrix, frequency distribution, and time series.

Metracker is still under development and in-house testing. We are now working on the data visualization portion that will graphically display the metric data. We plan to field test the prototype this year and enhance both the tool and the underlying data model through the lessons learned. As previously stated, we are also working within the framework of the IAI to incorporate performance metric data classes in future releases of the IFC.

By making this type of data broadly available to a variety of building industry software tools and end-users, we hope to continue toward our goal of a new generation of buildings that perform as intended by design.

### **Acknowledgments**

This work was supported by the Laboratory Directed Research and Development Funds of Lawrence Berkeley National Laboratory and by the U.S. Environmental Protection Agency, Office of Atmospheric Programs, Atmospheric Pollution Prevention Division; through the U.S. Department of Energy under Contract No. DE-AC03-76SF00098.

### **References**

- ASHRAE/IES (1989) *Standard 90.1-1989: Energy Efficient Design of New Buildings Except Low Rise Residential Buildings*. American Society of Heating, Refrigeration, and Air-Conditioning Engineers, Atlanta, GA, (cosponsored by Illuminating Engineering Society, New York, NY).
- Hitchcock, R.J., Selkowitz, S., Piette, M.A., Papamichael, K., and Olken, F. (1997) Building performance assurance through improved life-cycle information management and interoperable computer tools. *Proceedings of the Fifth National Conference on Building Commissioning*, April 28-30, Long Beach, CA.
- IAI. (1998) International Alliance for Interoperability. <http://iajweb.lbl.gov/>
- Larsson N. (Editor) (1993) *C-2000 Program Requirements*. CANMET, Natural Resources Canada, October 1993.

**ERNEST ORLANDO LAWRENCE BERKELEY NATIONAL LABORATORY  
ONE CYCLOTRON ROAD BERKELEY, CALIFORNIA 94720**