

Lawrence Berkeley National Laboratory

LBL Publications

Title

Cost of High Field Nb₃Sn and Nb-Ti Accelerator Dipole Magnets

Permalink

<https://escholarship.org/uc/item/0rv9f3v5>

Author

Hassenzahl, W V

Publication Date

1983-06-01

Copyright Information

This work is made available under the terms of a Creative Commons Attribution License, available at <https://creativecommons.org/licenses/by/4.0/>



Lawrence Berkeley Laboratory

UNIVERSITY OF CALIFORNIA

Accelerator & Fusion Research Division

RECEIVED
LAWRENCE
BERKELEY LABORATORY

AUG 20 1983

LIBRARY AND
DOCUMENTS SECTION

Presented at the 1982 Applied Superconductivity
Conference, Knoxville, TN, November 28 -
December 3, 1982

COST OF HIGH FIELD Nb₃Sn AND Nb-Ti ACCELERATOR
DIPOLE MAGNETS

W.V. Hassenzahl

June 1983

TWO-WEEK LOAN COPY
*This is a Library Circulating Copy
which may be borrowed for two weeks.
For a personal retention copy, call
Tech. Info. Division, Ext. 6782.*

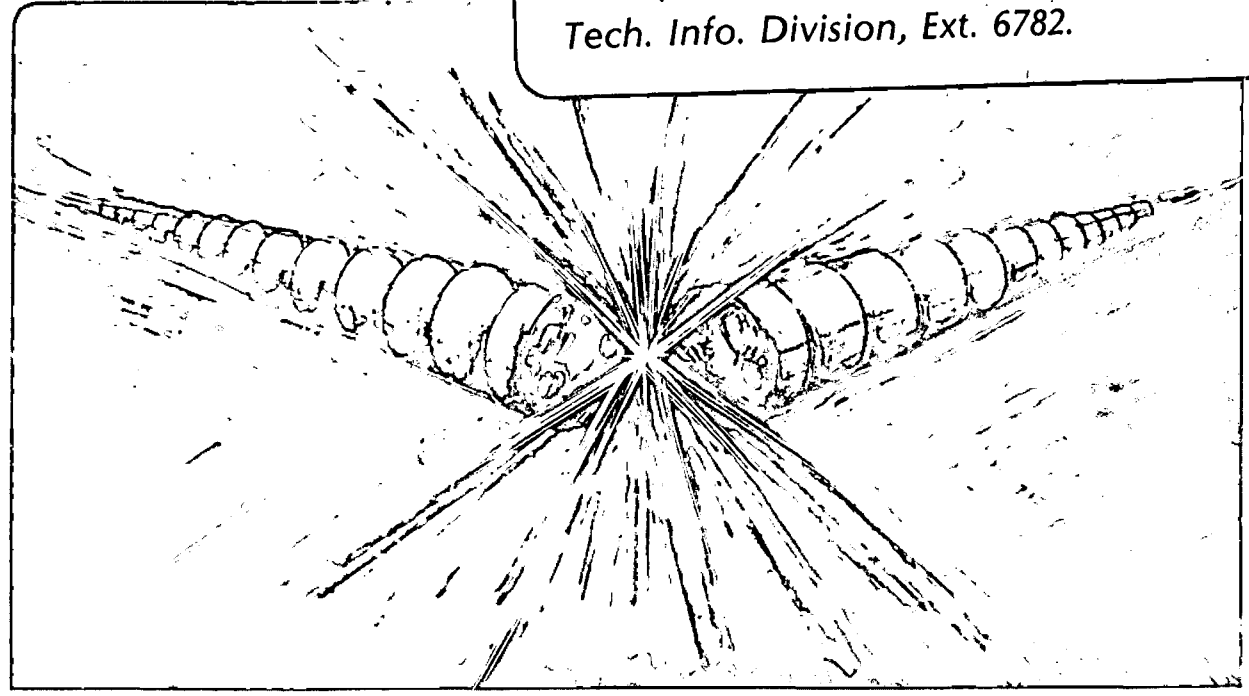

LBL-14918 RW.
c.2

DISCLAIMER

This document was prepared as an account of work sponsored by the United States Government. While this document is believed to contain correct information, neither the United States Government nor any agency thereof, nor the Regents of the University of California, nor any of their employees, makes any warranty, express or implied, or assumes any legal responsibility for the accuracy, completeness, or usefulness of any information, apparatus, product, or process disclosed, or represents that its use would not infringe privately owned rights. Reference herein to any specific commercial product, process, or service by its trade name, trademark, manufacturer, or otherwise, does not necessarily constitute or imply its endorsement, recommendation, or favoring by the United States Government or any agency thereof, or the Regents of the University of California. The views and opinions of authors expressed herein do not necessarily state or reflect those of the United States Government or any agency thereof or the Regents of the University of California.

LBL-14918
Revised 6/28/83

COST OF HIGH FIELD Nb₃Sn AND Nb-Ti
ACCELERATOR DIPOLE MAGNETS*

W.V. Hassenzahl

June 1983

Accelerator and Fusion Research Division
Lawrence Berkeley Laboratory
University of California
Berkeley, California 94720

*This work was supported by the Director, Office of Energy Research, Office of High Energy and Nuclear Physics, High Energy Physics Division, U. S. Dept. of Energy, under Contract No. DE-AC03-76SF00098.

COST OF HIGH-FIELD Nb₃Sn AND Nb-Ti
ACCELERATOR DIPOLE MAGNETS*

W. V. Hassenzahl

Future high-energy proton accelerators will likely require very high magnetic fields if the size of the accelerator and associated experimental areas are to be limited to dimensions that can be accommodated by the terrain at convenient sites. For example, the circumference of a 20 TeV, 10 T accelerator will be about 60 km. Two commercially available superconductors can be used to produce fields of 10 T or greater. The first is Nb₃Sn, which can operate in pool boiling helium at 4.4 K, the second is Nb-Ti, which must be cooled to about 1.9 K in superfluid helium. In this paper the costs of 7 to 11 T, 5 cm bore, 6 m long magnets made of these materials are compared. At 10 T the capital cost of Nb-Ti coils operating in superfluid helium is 35% less than the cost of Nb₃Sn coils and the cost is still 10% less after the differential operating costs over the life of the accelerator are included.

I. Introduction

The Energy Doubler/Saver at Fermilab will produce protons at about 1 TeV, which is almost twice as high as has been possible in the existing Fermilab accelerator. This energy is possible in the same tunnel because of

*This work was supported by the Director, Office of Energy Research, Office of High Energy and Nuclear Physics, High Energy Physics Division, U. S. Dept. of Energy, under Contract No. DE-AC03-76SF00098.

the higher operating field of the superconducting magnets. Future high-energy proton accelerators will require even higher magnetic fields unless new acceleration techniques are invented and developed or very large expanses of land are used. Though it may be possible to use lower fields in a large accelerator, about 10 T appears to be a reasonable goal considering the present capabilities of commercial superconductors. Two types of superconductors may be considered for operation at 10 T. The first is Nb_3Sn operating in pool boiling helium, at about 4.4 K. The second is Nb-Ti operating in superfluid helium at about 1.9 K. The ternary alloy Nb-Ti-Ta is not considered here because it is quite expensive and did not appear attractive in an earlier study.¹ This ternary may be effective in a hybrid magnet where it is used in only the highest field regions, in which case the costs developed here would be changed only slightly.

The design of the actual dipole magnets for future accelerators can only be guessed at here. However, at fixed field and fixed length, the cost of a dipole magnet will be roughly proportional to the inside diameter of the windings. Though the Fermilab doubler/saver has a 3" bore, smaller coils can be built. A 2" i.d. is certainly possible (two geometrically different 2" bore, 10 T dipoles are now under development at LBL), and even smaller coils could be built. At present the trade-offs between aperture and beam intensity are not known. However, because they appear feasible for an accelerator, only 2" bore dipoles are considered here.

The doubler/saver coils are almost 7 m long, and detailed information on component cost has been made available by Fermilab. The magnet cost can be broken down in several ways, one of which is to separate out the cost of the ends and then vary the length of the coil as desired. At 6 m there will be about 10,000 magnets in a 20 TeV accelerator. Clearly, reducing this

number would be desirable, and longer magnets will probably be used in a real accelerator if the problem of protection can be solved. To simplify this study, however, the coils considered here are 6 m long and the Fermilab costs are used directly. This approach allows for a reasonable comparison of the different fields and conductors, a comparison that will not change significantly with length.

As a further comparison, costs of Nb-Ti coils operating at 4.4 K are also included in this study. These coils are limited to about 9 T, at which field they are quite expensive. In addition, a 5 T coil is included to provide a link to existing accelerator magnets. No attempt is made to include or estimate the other costs of an accelerator.

II. Superconductor Costs

Good estimates can be made of production costs of Nb₃Sn and Nb-Ti because these materials have already been produced in relatively large quantities. In the case of Nb₃Sn some slight extrapolation to larger production runs is needed, but well developed rules can be satisfactorily applied to the existing production data to predict future costs.

A total of about 10⁵ kg of Nb-Ti cable having a copper to superconductor ratio of 1.8 was produced for the doubler/saver by several manufacturers. The actual cost of raw materials and fabrication of this conductor are given in Table I. These costs were supplied by Adam et al. of Airco² but are very similar to costs reported by Fermilab³ and those obtained from other manufacturers during an economic evaluation of superconducting magnetic energy storage.⁴ Recent studies^{5,6} of Nb-Ti superconductors have shown that some specially processed materials have current densities considerably higher than the Fermilab specifications. The

Table I

Production Costs of Nb-Ti Superconducting Wire
Based on 82% Yield of the Extrusion

Nb-Ti rod	($\rho = 6.05$)		\$80.00/lb
Cu	($\rho = 8.94$)		\$3.50/lb
Materials	Cu/SC = 1.8:1		\$29.90/lb
	Cu/SC = 1.0:1		\$41.90/lb
Fabrication			\$17.00/lb
Fabricated Conductor Costs			
FNAL Specification	}	1.8:1	\$46.90/lb
Conductor		1:1	\$59.00/lb
High Current	}	1.8:1	\$49.40/lb
Density Conductor		1:1	\$61.50/lb

special processing includes an additional heat treatment during wire drawing to improve the micro structure of the Nb-Ti filaments. These conductors will be somewhat more expensive because the handling and fabrication costs may increase by as much as 15%, the incremental increase used here. Assuming an 82% yield and special processing, the 1.8:1 conductor will cost about \$51/lb and the 1:1 about \$63/lb.

The fabrication and raw materials costs for Nb₃Sn multifilamentary wire made with the bronze process are given in Table II. Whereas the raw materials were the major cost in the Nb-Ti conductor, the fabrication costs are the largest for the bronze process Nb₃Sn. The Nb₃Sn bronze process conductor requires 10 to 30 anneals during processing to maintain ductility and avoid damage; by comparison the Nb-Ti conductor requires only one (or for the specially processed materials two) heat treatment near the final strand size to insure good copper resistance and to enhance J_c. The fabrication costs in Table II are somewhat less than the actual costs of the LCP conductor,⁷ because they are adjusted to reflect production of Nb₃Sn conductors in quantities comparable to those already fabricated for the Fermilab doubler/saver.

The LCP conductor has a niobium barrier between the bronze matrix and the copper stabilizer. After reaction a superconducting layer exists on the inside surface of this barrier and could be a source of large ac losses in a rapidly cycled magnet. An alternative barrier material is tantalum, which is both more dense and more expensive than niobium. A conductor similar to the LCP conductor but with a Ta barrier would cost \$75/lb instead of \$62/lb and the proposed 1:1 conductor would cost \$78/lb instead of \$66/lb.

The production cost of bronze process conductor made in large quantities is used in this study even though several other production

Table II

Production Costs for Bronze Process Nb₃Sn Superconducting
Wire Based on Large Scale Production

Nb rod	($\rho = 8.4$)	\$80/lb
Nb sheet	($\rho = 8.4$)	\$80/lb
Cu	($\rho = 8.94$)	\$3/lb
Bronze	($\rho = 8.7$)	\$10/lb
Materials	Cu/S.C. = 1.7:1	\$21.80/lb ^a
	Cu/S.C. = 1:1	\$25.60/lb
Fabrication Cost		\$40.00/lb
Fabricated Conductor	at 1.7:1	\$61.80/lb ^b
Fabricated Conductor	at 1:1	\$65.60/lb ^b

a. Area fractions from LCP conductor (60% Cu, 5% Nb Barrier, 9% Nb filaments, 26% Bronze). A tantalum barrier will increase the cost considerably.

b. Assumes 80% yield in each of 2 extrusions

methods have been proposed for multifilamentary Nb_3Sn . The hope for these methods is that they will provide a high current density and that both material and fabrication costs will be lower than for bronze process Nb_3Sn . Though a breakthrough is possible, it cannot be predicted and any potentially lower costs may be introduced easily to the component costs included here and then new estimates made of total magnet costs. Thus the costs for large scale production of bronze process conductor are used in this study.

Recently several Nb_3Sn conductors with tin rich regions have been developed and are now commercially available.⁸⁻¹⁰ Because production costs are not available these materials are not used in this evaluation, but they are expected to be less expensive to produce than the bronze process materials as there is no need for extrusion or intermediate heat treatments.

The costs of superconductors are frequently given in the unit ($\$/kAm$), which reflects the current carrying capacity of the conductor and is thus a better measure of the value or effectiveness of a given conductor. To obtain the cost of various materials in this unit it is necessary to measure or estimate the working current density in the proposed superconductors. Either conservative or optimistic estimates of the current densities can be used in cost estimates. Because this study is aimed at magnets that will be constructed in five to ten years somewhat optimistic current densities have been used for both Nb-Ti and Nb_3Sn . The current densities used and some comparative values are given in Fig. 1 and Table III. The current densities for Nb-Ti are based on some recent measurements on small-scale, commercially produced conductors.^{5,6} The Nb_3Sn current densities are based on projections of current densities that could be possible supposing one of the new processes mentioned above that use higher Nb and Sn content

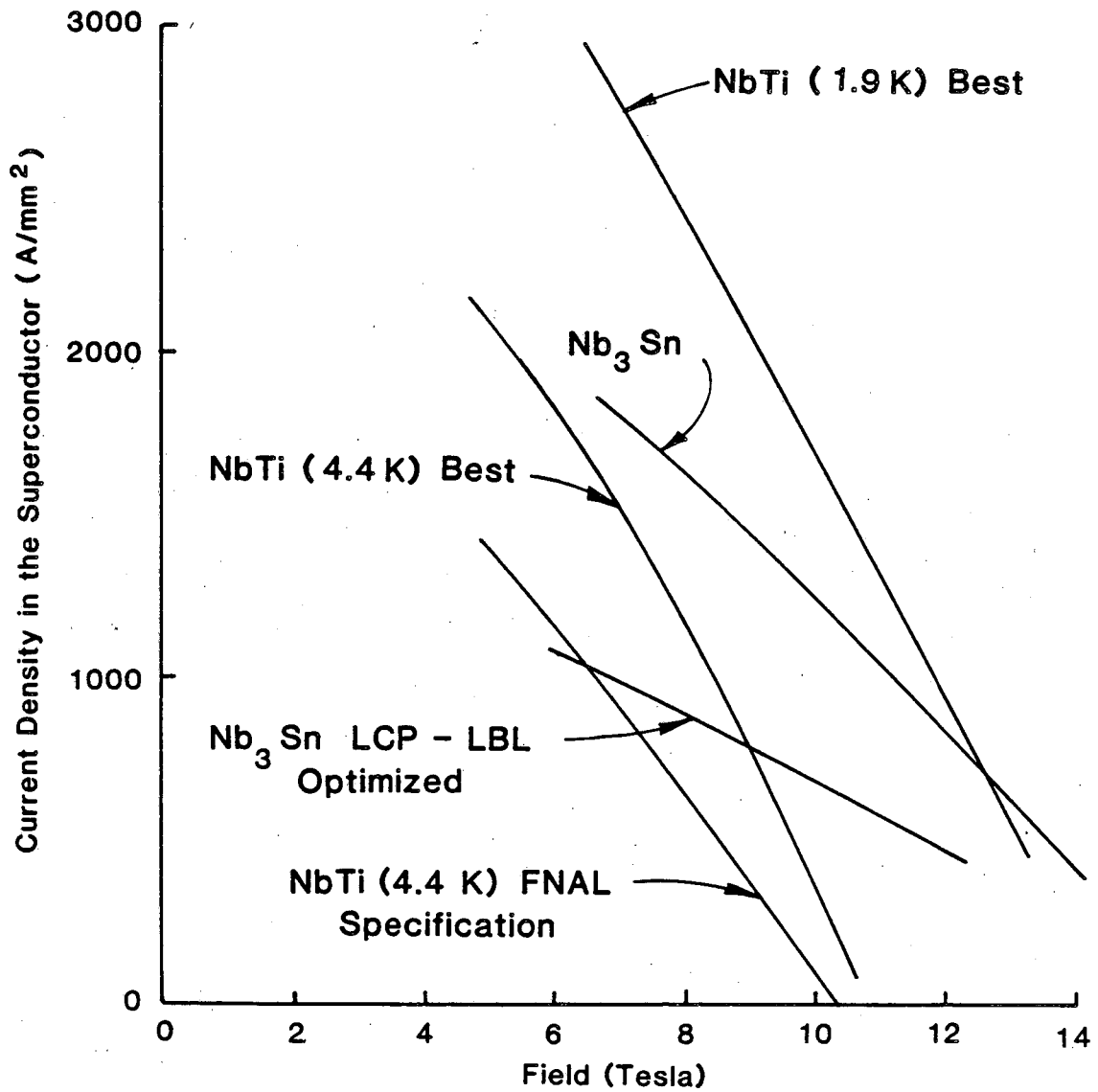

XBL 8210-3095

Fig. 1. Critical Current Density as a Function of Magnetic Field for Various Conductors. The Three Highest Curves Were Used for Estimating Magnet Material Requirements in this Study

Table III

Current Densities A/mm^2 in the Superconductor
for Conductors Made of Nb-Ti and Nb_3Sn

Field (T)	Nb-Ti (4.5 K)		Nb-Ti (1.9 K)		Nb_3Sn (4.5 K)		
	FNAL	Best ^a	FNAL ^c	Best ^a	LCP ^d	Proposed ^b	
145	1400	2100	-	-	-	-	
	7	900	1450	2060	2800	1000	1790
	8	660	1200	1710	2300	900	1610
	9	340	760	1360	1960	800	1450
	10	100	350	1050	1620	700	1250
	11	-	-	700	1250	580	1040
	12	-	-	380	900	470	840

a. Best values are based on current densities observed in a few samples

b. Proposed values are based on increasing the A15 cross sectional area

c. Estimated from 4.2 K data

d. Optimized heat treatment for LCP conductor $700^\circ C-2$ days + $730^\circ C-2$ days;
 J_c in LCP is $\approx 500 A/mm^2$ at 10T

is developed. The current densities in Table III and the costs in Tables I and II are used to calculate the cost of materials in \$/kAm as given in Fig. 2 and Table IV.

SUPERCONDUCTOR REQUIREMENTS FOR MAGNETS

The amount of superconductor required for a coil depends on the working current density in the conductor, the coil design, and the placement of iron, if it is used. Each of these items is discussed separately below and then the material requirements for specific coil configurations using Nb-Ti and Nb₃Sn are developed.

The possible current densities available in conductors were given in Table III and Fig. 1. Though it may be possible to achieve a given current density in a conductor sample, to approach that same current density in a real magnet may be very difficult if not impossible, and a working current density must be established. The working current density is set below the critical current density by 20% for Nb₃Sn and 10% for Nb-Ti. The current density in the coil windings will be further decreased by the stabilizer, insulation, and helium cross section. For the conductors in this study, which have 50% stabilizer, the maximum possible current density in the winding will be about 38% of that in the superconductor. This "packing fraction" is used for both Nb-Ti and Nb₃Sn conductors though the actual maximum current densities in fabricated magnets may vary by a few percent. Adjusting the current densities by the factors mentioned above results in the working current densities in the coil winding given in Table V.

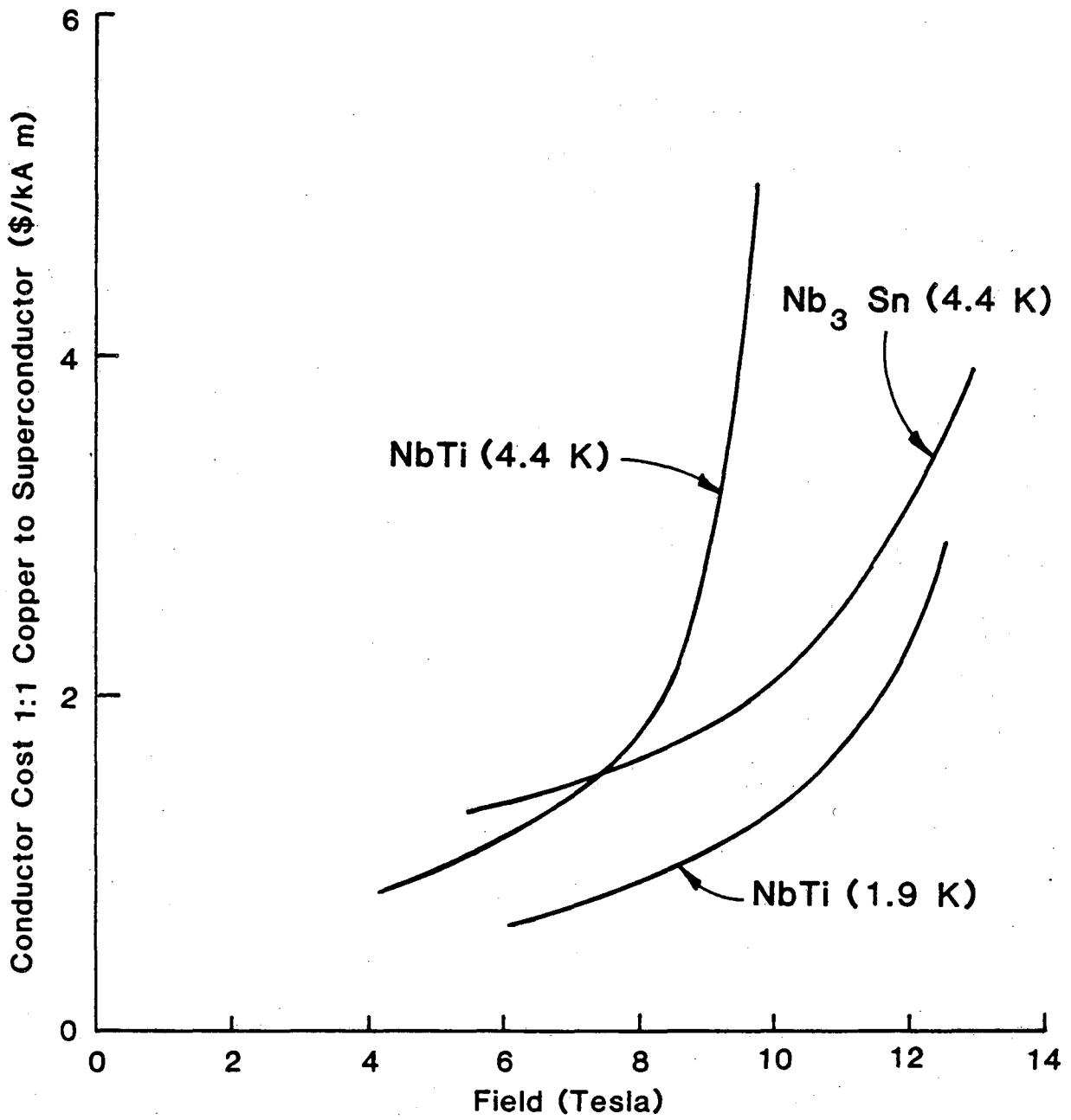

XBL 8210-3093

Fig. 2. Unit Conductor Cost for the Three Materials Used in this Study

Table IV

Conductor Cost /in ($\$/kAm$) as a Function of Field for Nb-Ti and Nb₃Sn
 Conductors with 50% Stabilizer Cross Section

Field (T)	Nb-Ti		Nb ₃ Sn
	4.2 K	1.9 K	4.2 K
5	1.00		
7	1.44	0.75	1.45
8	1.74	0.91	1.62
9	2.75	1.07	1.79
10	5.98	1.29	2.08
11		1.67	2.50
12		2.32	3.10

Table V

Working Current Densities in Superconducting Magnet Windings (A/mm^2)

Field (T)	Nb-Ti		Nb ₃ Sn
	4.2 K	1.8 K	4.2 K
5	718		
7	496	958	544
8	410	787	489
9	260	670	440
10	119	554	380
11		428	316
12		308	255

Because conductor at a large radius contributes proportionately less to the central field than conductor close to the bore a high current density reduces the total conductor (ampere turn) requirements.

The effectiveness of a quantity of superconductor in terms of producing a given field is also affected by the coil design. On the average the conductor in the block design, Fig. 3a, is farther from the bore than the conductor in the layer design, Fig. 3b. Assuming the same current density is possible in the conductor, this effect requires that about 5 to 10% more conductor be used for a block coil than for a layer coil. The cause of this difference is that the block design requires a central support system to oppose the external compressive forces of the structure while these forces are intrinsically supported in the layer design.

In comparing the Nb-Ti vs Nb_3Sn coils the different conductor characteristics that determine coil geometry become important. Though Nb-Ti can be used in both configurations and the brittle nature of Nb_3Sn may require the construction techniques associated with the block geometry, only layer magnets are considered in this study. Small adjustments (10%) to the cost figures can be used to account for the difference if necessary, but it appears that the numbers at present do not warrant a more accurate calculation. Field calculations for the two designs show that both can produce acceptable field quality.

The superconducting dipoles for the Fermilab doubler/saver ring use warm iron and the Isabelle magnets at Brookhaven use cold iron to increase the internal field, to shield the beam from external fields, to limit the effects of the field outside the coils, and to reduce the forces between the coil and any external ferromagnetic material that is not symmetrically distributed with respect to the beam. Surprisingly, the

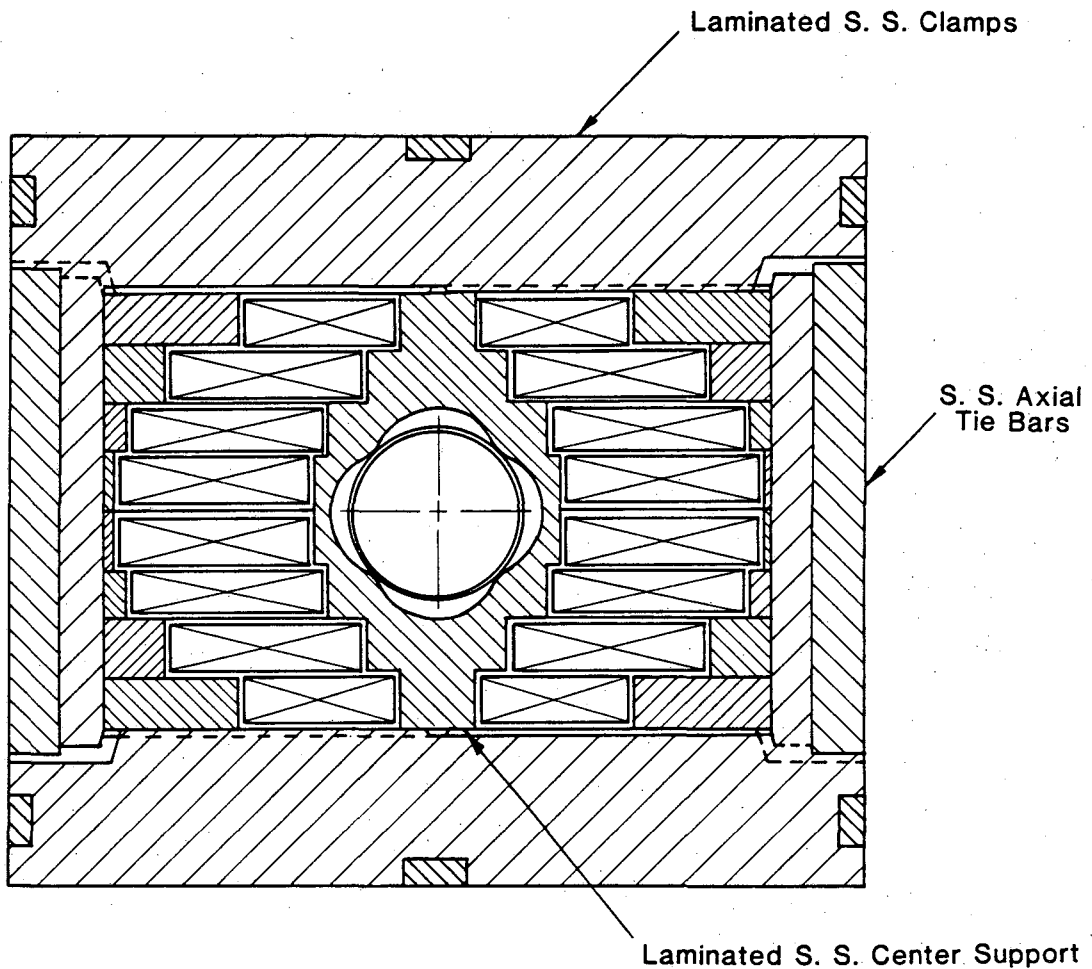

10 TESLA DIPOLE MAGNET BLOCK WINDING

XBL 825-9774

Fig. 3a. Cross Section of a Block Design Coil that Could Be Used for a 10 T Accelerator Dipole

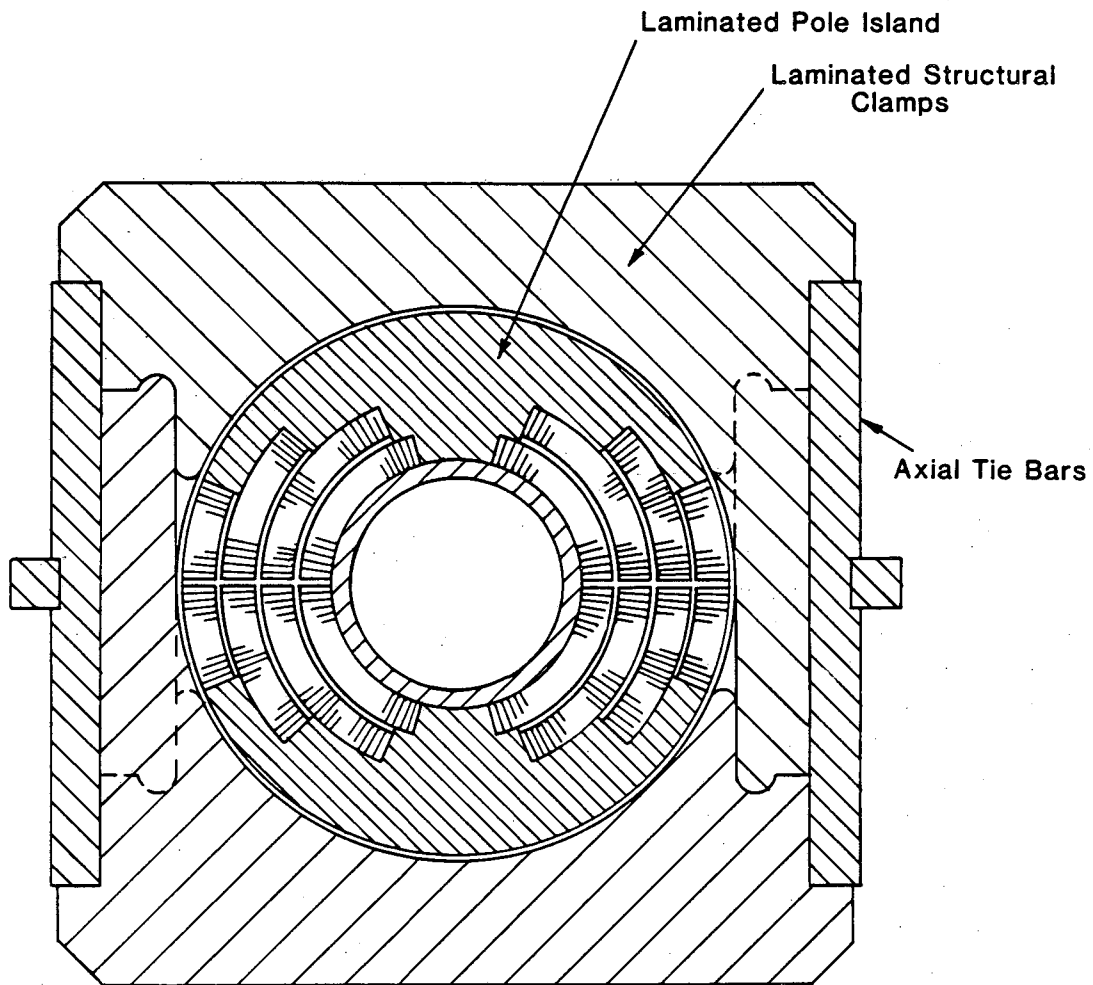

10 TESLA DIPOLE MAGNET LAYER WINDING

XBL 825-9775

Fig. 3b. Cross Section of a 4 Layer Coil that Could Be Used for a 10 T Accelerator Dipole

quantity of iron required to achieve complete shielding is almost independent of the distance between the inside of the iron and the coil.⁸ This means that the iron can be cold or warm or even some combination of the two and still have about the same volume and mass, and therefore cost, for a given magnet. Though magnetic iron or mild steel is relatively brittle at low temperature it can be used in low stress conditions to support some of the magnetic load and thus replace other structural material such as aluminum or stainless steel. On the other hand the use of cold iron will increase the size and therefore the cost of the cryostat.

The effect of iron on a "normalized" dipole load line for a layer coil capable of producing about 10 T is given in Table VI and shown in Fig. 4. Because the iron saturates and has little effect after about 4 T, the field enhancement of 0.36 T in a 10 T magnet is about a factor of 3 less than the 1 T expected in a 4 T magnet. The distance of the iron from the coil affects not only the dipole field magnitude, but also the field quality, in particular the sextupole component. The effect on the sextupole component of iron having infinite permeability is given in Table VI. About 0.5% sextupole can be produced if the iron is close to the coil, and the windings have been designed for zero sextupole with no iron. (Note that the coil may be designed to have zero sextupole at low field or at high field but not both.) This effect has not been calculated here for saturable iron so the true effect in a magnet is not precisely known, but the effect of saturation will probably be to push the effective iron radius out as the field increases so one would expect the change of the sextupole to be less, maybe about about 0.3% at 10 T.

Two, three, and four layer magnet designs were studied to determine the quantity of superconductor required to achieve fields between 7 and 12 T. A

Table VI

The Effect of Iron Having an Infinite Permeability on the Load Line Before Saturation, the Operating Field, and the Sextupole Field of a Layer Coil. The Outside of the Conductor is at 73 mm.

Iron Inside Radius (mm)	Load Line (Arbitrary Units)	Operating Dipole Field (T)	Sextupole* (% of dipole)
80	1.43	10.36	0.487
100	1.27	10.23	0.450
130	1.16	10.16	0.340
∞	1.00	10.0	$< 10^{-4}$

*This coil's shape was optimized for no iron, and the shape was not changed as the iron was moved towards the coil. The optimization could have been for iron at 80 mm in which case the sextupole would have been 0.49% when the iron was at ∞ .

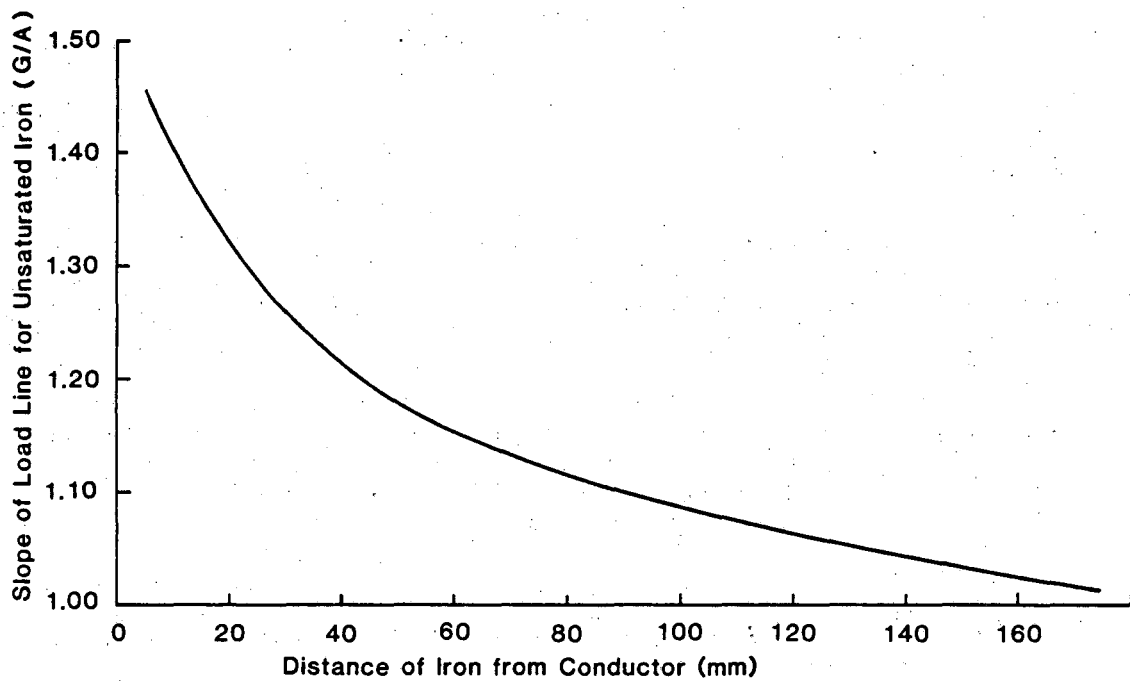

XBL 8210-2094

Fig. 4. The Effect of Iron Position on the Slope of the Load Line for a 10 T Dipole Magnet

single point at 5 T for Nb-Ti at 4.4 K has been included to relate this study to existing accelerator magnet designs.^{9,10} In addition, some recent calculations by Peters¹¹ of the field near the pole region of multilayer magnets indicate that at high fields the maximum enhancement will be about 4%. These same calculations included a determination of the fields at the pole region of the outer layers so that load lines can be established for coils with graded conductors. Good field quality was required for these magnets, but, for the 2 layer coils in particular, the harmonics were minimized but not made zero. Smaller harmonics could be achieved with the addition of wedges in the coil cross section. The conductor requirements established by this analysis are shown in Fig. 5 and presented in Table VII. Both cross sectional area and Ampere turn requirements are included in Table VII. The conductor requirements for coils with cold iron are shown in Table VIII and Fig. 6.

The conductor costs for 6-m long magnets are found directly by combining the unit conductor costs in Table IV and the conductor requirements in Table VII and are listed in Table IX and shown in Fig. 7. Similarly the conductor costs for 6-m long magnets with cold iron are found in Table X and Fig. 8.

The effect of the use of cold iron on the total conductor requirement is given in Table XI and Fig. 9, where the values listed are the ratios of the amount of conductor required with iron to the amount required without iron, or equivalently with warm iron. Because warm iron contributes so little to the field, the terms warm iron and no iron are used interchangeably. The ratio increases with field showing that the effectiveness of the iron decreases.

The cost of iron, cryostat, refrigeration system and fabrication for high field magnets can be related to the cost of these items for the

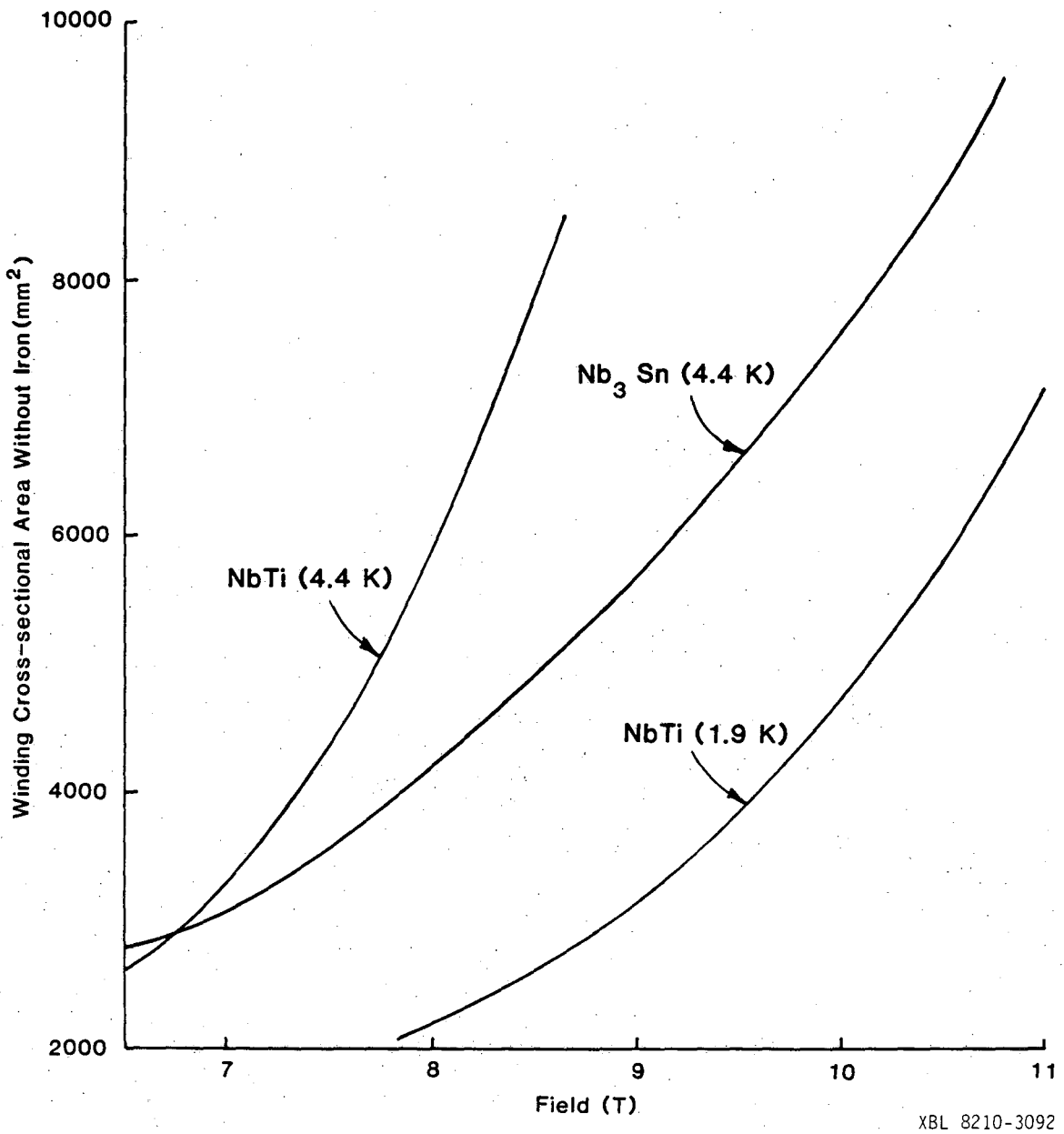

Fig. 5. Cross Sectional Area of the Windings as a Function of Magnetic Field

Table VII

Cross Sectional Area and Ampere Turn Requirements for
Nb-Ti and Nb₃Sn Coils Operating at Various Fields without Iron

Field (T)	Nb-Ti (4.2 K)		Nb-Ti (1.9 K)		Nb ₃ Sn (4.2 K)	
	Area (mm ²)	A Turns x 10 ⁶	Area (mm ²)	A Turns x 10 ⁶	Area (mm ²)	A Turns x 10 ⁶
5	1300	0.47	-	-	-	-
7	3300	0.82	-	-	3100	0.843
8	5900	1.21	2200	0.87	4200	1.03
9	11000	1.43	3150	1.06	5700	1.25
10	-	-	4800	1.33	7600	1.45
11	-	-	7200	1.54	10200	1.61

Table VIII

Cross Sectional Area and Ampere Turn Requirement at Various Fields
for Nb-Ti and Nb₃Sn Coils with Iron Close to the Conductor (Cold Iron)

Field (T)	Nb-Ti (4.2 K)		Nb-Ti (1.9 K)		Nb ₃ Sn (4.2 K)	
	Area (mm ²)	Ampere Turn x 10 ⁶	Area (mm ²)	Ampere Turns x 10 ⁶	Area (mm ²)	Ampere Turns x 10 ⁶
5	1000	0.36	-	-	-	-
7	2520	0.62	-	-	2350	0.64
8	4300	0.88	1670	0.66	3250	0.80
9	8900	1.16	2500	0.84	4650	1.02
10	-	-	3950	1.09	6500	1.24
11	-	-	6350	1.36	9150	1.45

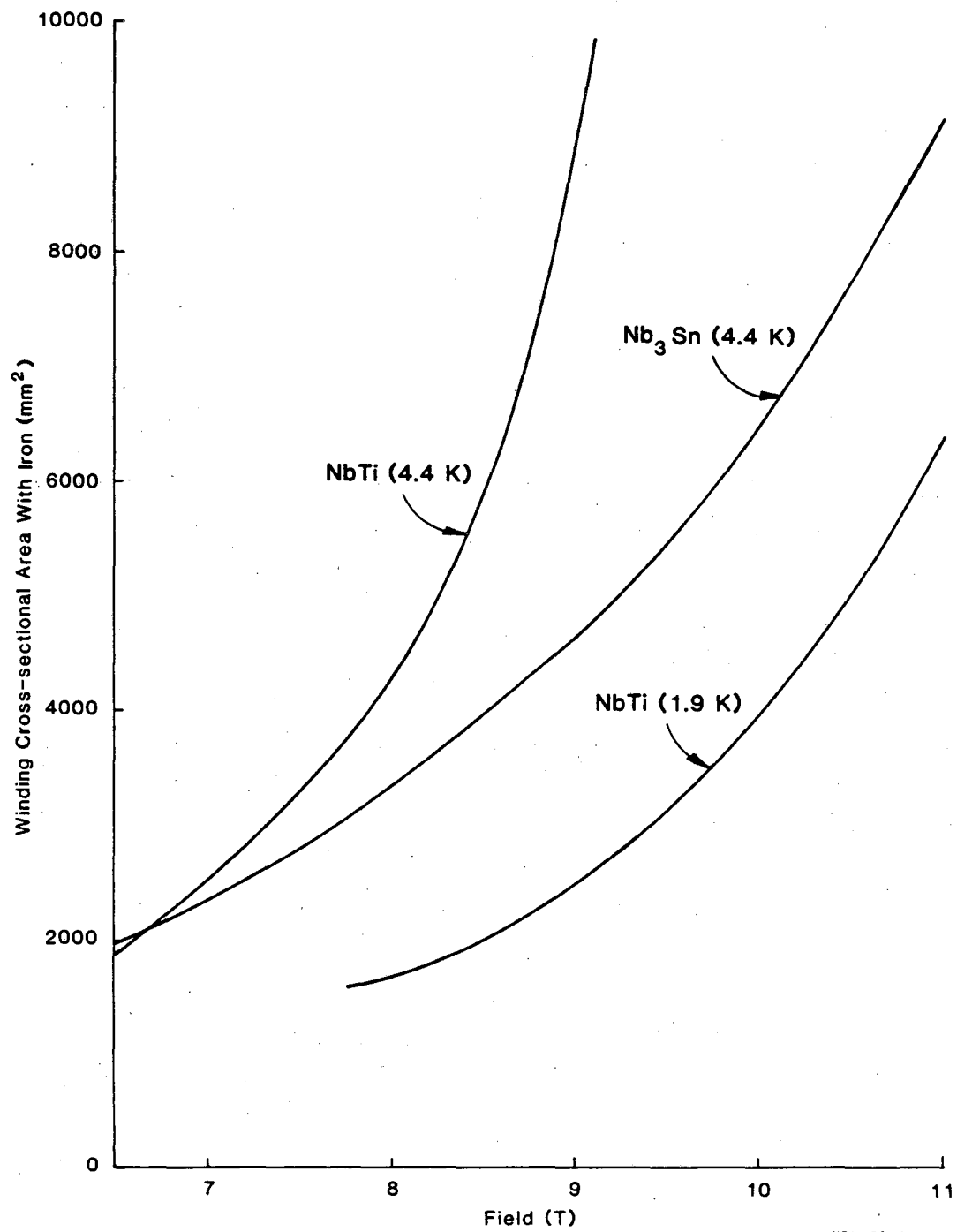

XBL 8210-3086

Fig. 6. Conductor Requirements as a Function of Field for Coils Having Cold Iron

Table IX

Cost in Dollars for the Superconductor in 6 m Long Dipoles Having Warm Iron

	Nb-Ti	Nb-Ti	Nb ₃ Sn
Field	4.2 K	1.9 K	4.2 K
5	5640	-	-
7	14170	-	14670
8	25260	9500	20020
9	47190	13610	26850
10	-	20590	36190
11	-	31260	48300

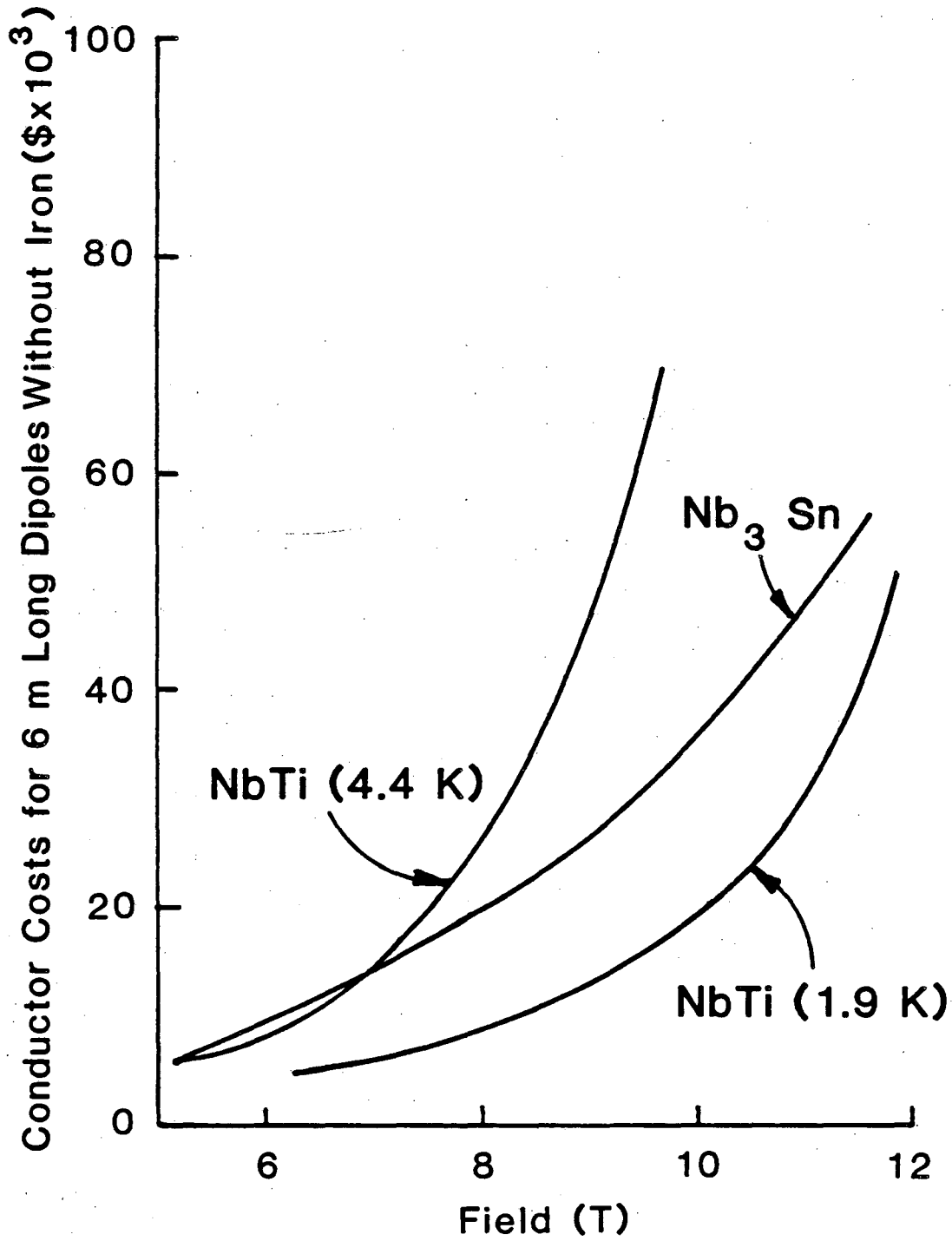

XBL 8210-3087

Fig. 7. Conductor Costs for 6-m Long Dipoles without Iron as a Function of Field

Table X

Cost in Dollars of the Superconductor for 6-m Long Dipoles Having Cold Iron

Field (T)	Nb-Ti		Nb ₃ Sn
	4.2 K	1.9 K	42 K
5	4300	-	-
7	10710	-	11140
8	18370	7210	15550
9	38280	10790	21910
10	-	16870	30950
11	-	27250	43500

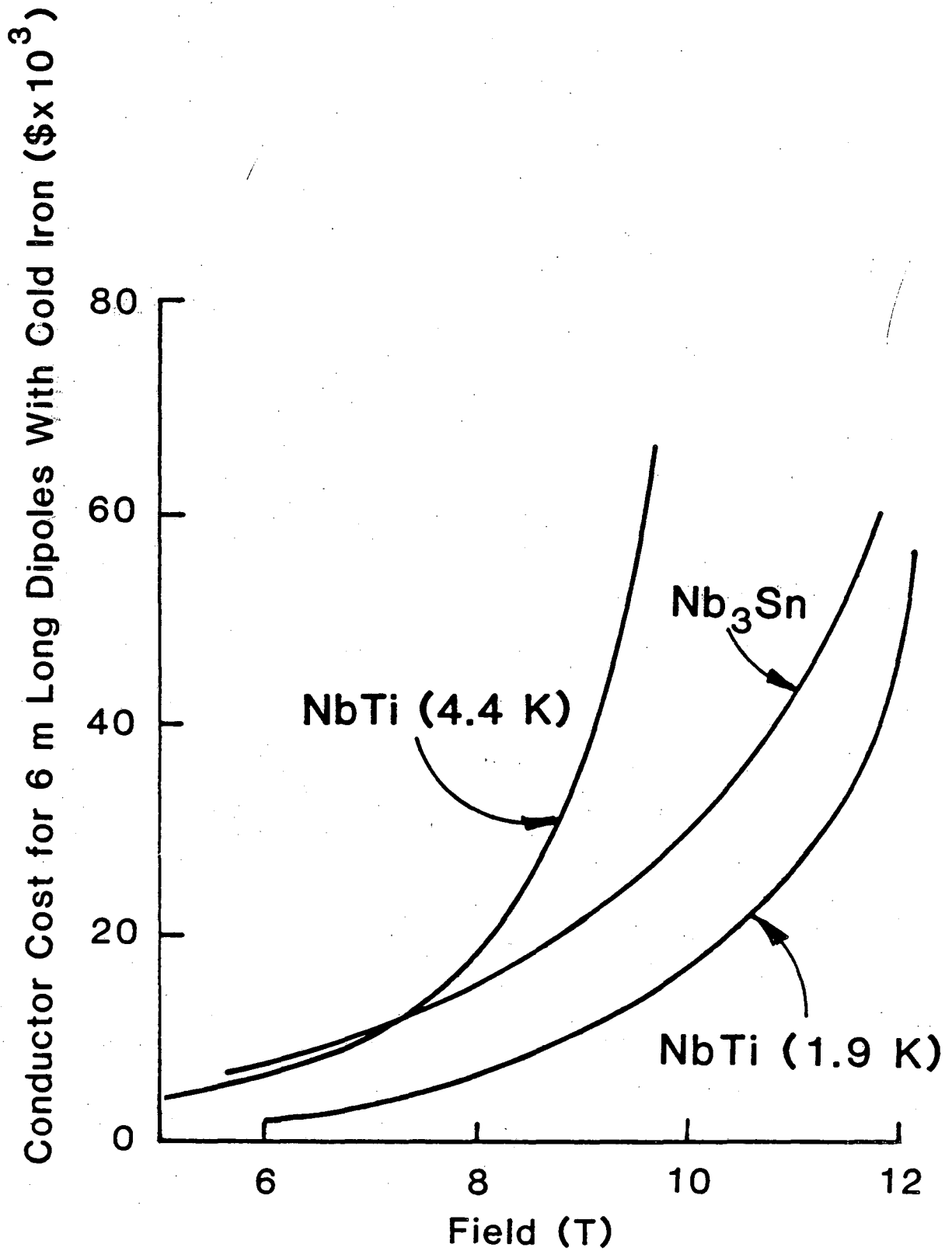

XBL 8210-3086

Fig. 8. Conductor Costs for 6-m Long Dipoles with Cold Iron as a Function of Field

Table XI

A Comparison of the Conductor Requirements for Coils Having Cold Iron and Coils Having No Iron. The Values Listed are the Ratios of the Ampere Turns Required in Coils without and with Iron

Field (T)	4.2 K	1.9 K	Nb ₃ Sn 4.2 K
5	0.76	-	-
7	0.76	-	0.76
8	0.79	0.76	0.78
9	0.81	0.79	0.82
10	-	0.82	0.86
11	-	0.88	0.90

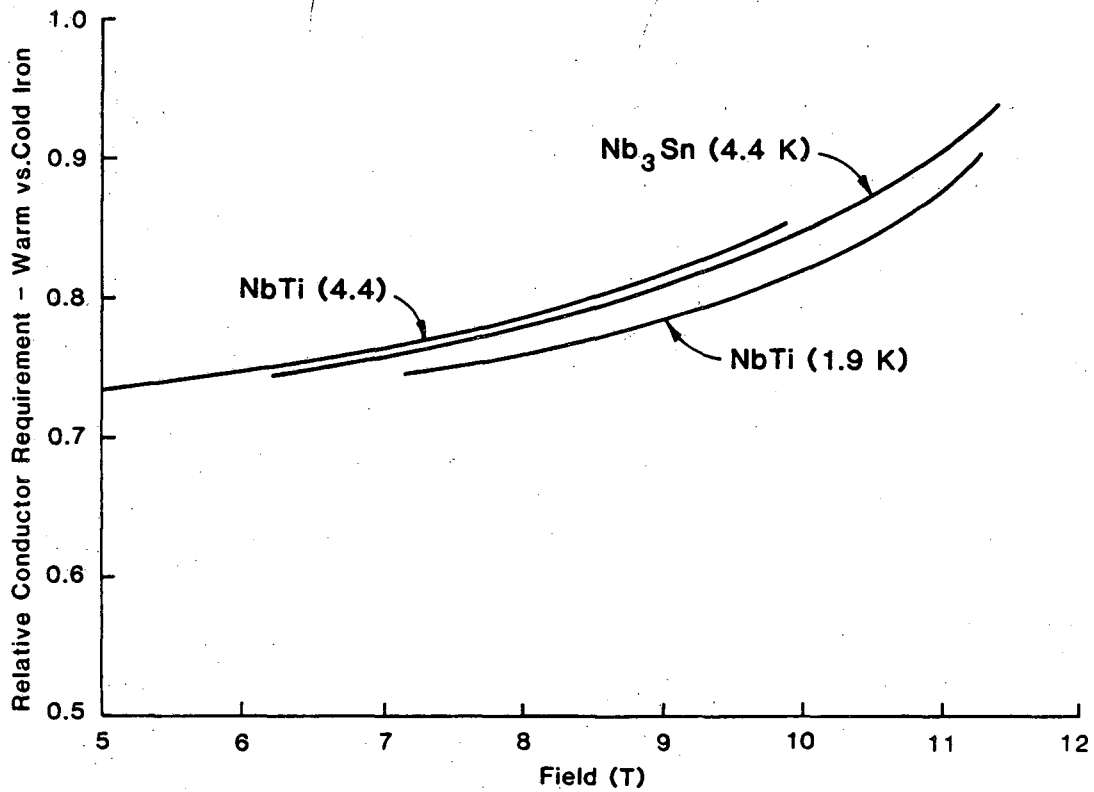

XBL 8210-3091

Fig. 9. A Comparison of the Conductor Requirements for Coils with and without Iron. The Ratio of the Conductor Needed for a Cold Iron Magnet to that Needed for a Warm Iron Magnet is Given. The Ratio Approaches 1 as the Field Increases.

Fermilab energy saver/doubler. The cost of each component of the FNAL dipole as assembled in a cryostat is given in Table XII.⁹

The conductor comprises about half of the materials costs and about 30% of the total magnet cost. The extrapolation of the 4.4 K Nb-Ti costs in Fig. 6 to 4.5 T gives a conductor cost of \$6.5 k, which is about one half of the cost of the conductor for the FNAL doubler/saver coils. The factor of two can be accounted for almost exactly by: the difference in conductor required for a 2.0" and a 3.0" bore magnet, the slightly different coil length, the different current densities, and the use of copper to superconductor ratio of 1 in this study rather than the FNAL conductor ratio of 1.8.

The cost of superconductor in a cold iron magnet was given in Table X. The cost of coil parts in the Fermilab magnets are about 37% of the conductor cost. Because there are higher stress levels at higher fields a larger fraction of other materials might be required. However, the current density decreases as field increases, which tends to offset the effect of stress, as more conductor is also required. In addition, the use of cold iron will further offset any increased materials costs as it will replace some of the stainless steel support. Without a strong reason to change this proportion, the cost of coil parts is assumed to be 37% of the cost of conductor for 4.4 K Nb-Ti coils. The cost of parts for Nb₃Sn coils will be greater because of the lower allowable strains and additional supports, such as internal structure needed in the block design. This effect is estimated to increase the coil parts cost by at least 30% (Nb₃Sn = 0.3). In the Nb-Ti coils at 1.9 K the forces will be greater per unit volume of superconductor so a 10% increase in cost is estimated for the 1.9 K Nb-Ti magnets (1.9 K = 0.1). The cost of coil parts is then

Table XII

Component Costs and Manpower Requirements for the
Fermilab Energy Double/Saver Dipoles

Conductor	13,000
Coil Parts	4,800
Cryostat Parts	4,000
Iron	3,500
Misc.	<u>2,000</u>
Total Parts	\$27,300
Coil Winding and Assembly	200
Cryostat Assembly	200
Iron Assembly	80
Final Assembly	<u>120</u>
	600 hrs

$$C_{\text{coil parts}} = 0.37 \times C_{\text{conductor}} \times (1 + C_{\text{Nb}_3\text{Sn}} + C_{1.9 \text{ K}})$$

The cost of the cryostat parts will depend somewhat but not strongly on diameter. The major effect will be due to the use of cold or warm iron. Assuming cold iron is used, the cost can be approximated by

$$C_{\text{cryostat}} = \left(5000 + 1000 \frac{B}{5} \right) (1 + C'_{1.9 \text{ K}})$$

where $C_{1.9 \text{ K}}$ is 0.25 for 1.9 K operation and is otherwise zero. The 25% increase in cost includes heat exchangers and additional heat shields required for 1.9 K operation.

The amount of iron can be determined from the size of the bore, the coil thickness, and the distance from the conductor to the iron. Though the quantity of iron required at a given field will decrease somewhat as the current density increases, this is a secondary effect. Thus

$$C_{\text{Fe}} = 2000 + \frac{B}{10} 2000$$

The miscellaneous costs are assumed to be proportional to the field and to be slightly higher for the coils operated at 1.9 K and Nb_3Sn coils.

$$C_{\text{Misc}} = \$2000 \frac{B}{5} \left(1 + C'_{1.9 \text{ K}} + C_{\text{Nb}_3\text{Sn}} \right)$$

The hours for assembly and fabrication given in Table XII are based on the last doubler/saver magnets constructed at FNAL. They provide a basis for a cost comparison of Nb₃Sn and Nb-Ti coils. The early production magnets fabricated in 1980 required about 1000 hrs for completion.

The coil winding will be roughly proportional to the number of layers. Thus 200h > 400 h for the Nb-Ti coils at 10 T. An additional 30% is charged to the Nb₃Sn coils because of reaction costs, etc. The coil fabrication and assembly and labor cost will increase with field. The dependence would have been on total conductor as given earlier in Figs. 5 and 6. The higher field magnets would then have a slightly higher relative fabrication cost. However, the greater the total effort the more likely it is to be fractionally decreased. The expression for the coil manufacturing and assembly cost is thus

$$C_{\text{winding}} = 400 \frac{B}{10} \left(1 + C_{\text{Nb}_3\text{Sn}} \right) W$$

The cryostat assembly cost will be almost independent of size, shape, use of Nb-Ti or Nb₃Sn, etc. but will depend somewhat on the operating field and the operating temperature:

$$C_{\text{cryo assy.}} = \left(125 + 100 \frac{B}{10} \right) \left(1 + C_{1.9 K} \right) W$$

The cost of the iron assembly will depend on the quantity of iron used, which depends on field and current density.

$$C_{\text{iron assy.}} = \left(60 + 40 \frac{B}{10} \right) W$$

The final assembly and the testing and measuring should not be much different for a 3" or a 2" bore magnet nor should the operating field make much difference. Thus \$2400 is used for all coils.

Using these values the total hours required to fabricate, assemble and test Nb-Ti and Nb₃Sn magnets are given in Table XIV and Fig. 8.

Combining all these individual costs and using a labor rate of \$20/hr, the costs of the various magnet components and the total costs for the different types of magnets are given in Tables XIII, XIV, and XV. In a previous study the effect on refrigeration cost of operating at 1.9 K was shown to contribute about 25% to the total magnet cost, based on the magnet and refrigerator costs for Isabelle. The 1.9 K magnet costs in Table XIV are increased by this same factor to obtain an adjusted total cost that can be compared with the cost of other coils. Each of these costs is shown in Fig. 10.

Table XIII

Cost of Cold Iron Nb-Ti Magnets Operated at 4.4 K

	5	7	8	9
Conductor	\$ 4300	\$10710	\$18370	\$38280
Coil Parts	1590	3960	6800	14160
Cryostat Parts	6000	6400	6600	6800
Iron	3000	4100	4400	4700
Misc.	<u>2000</u>	<u>2800</u>	<u>3200</u>	<u>3600</u>
Total Parts	\$16890	\$27970	\$39370	\$67540
Coil Winding & Assy.	\$ 4000	\$ 5600	\$ 6400	\$ 7200
Cryostat Assy.	3300	3900	4100	4300
Iron Assy.	1600	1760	1840	1920
Final Assy.	<u>2400</u>	<u>2400</u>	<u>2400</u>	<u>2400</u>
	\$11300	\$13660	\$14740	\$15820
	\$28190	\$41630	\$54110	\$82820

Table XIV

Cost of Nb-Ti Magnets Operated at 1.9 K

Field (T)	8	9	10	11
Conductor	\$ 7210	\$10790	\$16870	\$27250
Coil Parts	2960	4390	6870	11090
Cryostat Parts	8250	8500	8750	9000
Iron	4400	4700	5000	5300
Misc.	<u>3520</u>	<u>3960</u>	<u>4400</u>	<u>4840</u>
Total Parts	\$26340	\$32340	\$41890	\$57480
Coil Winding & Assy.	6400	7200	8000	8800
Cryostat Assy.	5130	5380	5630	5880
Iron Assy.	1840	1920	2000	2080
Final Assy.	<u>2400</u>	<u>2400</u>	<u>2400</u>	<u>2400</u>
	15770	16900	18030	19160
Total	\$42110	\$49240	\$59920	\$76640
Total w 25% Extra for Refrig.	\$52640	\$61550	\$74900	\$95800

Table XV

Cost of Nb₃Sn Magnets Operated at 4.4 K

Field (T)	8	9	10	11T
Conductor	\$15550	\$21910	\$30950	\$43500
Coil Parts	7480	10540	14890	20920
Cryostat Parts	6600	6800	7000	7200
Iron	4400	4700	5000	5300
Misc.	<u>4160</u>	<u>4680</u>	<u>5200</u>	<u>5720</u>
Total Parts	\$38190	\$48630	\$63040	\$82640
Coil Winding & Assy.	\$ 8320	\$ 9360	\$10400	\$ 11440
Cryostat Assy.	4100	4300	4500	4700
Iron Assy.	1840	1920	2000	2080
Final Assy.	<u>2400</u>	<u>2400</u>	<u>2400</u>	<u>2400</u>
	\$16660	\$17980	\$19300	\$ 20620
	\$54850	\$66610	\$82340	\$103260

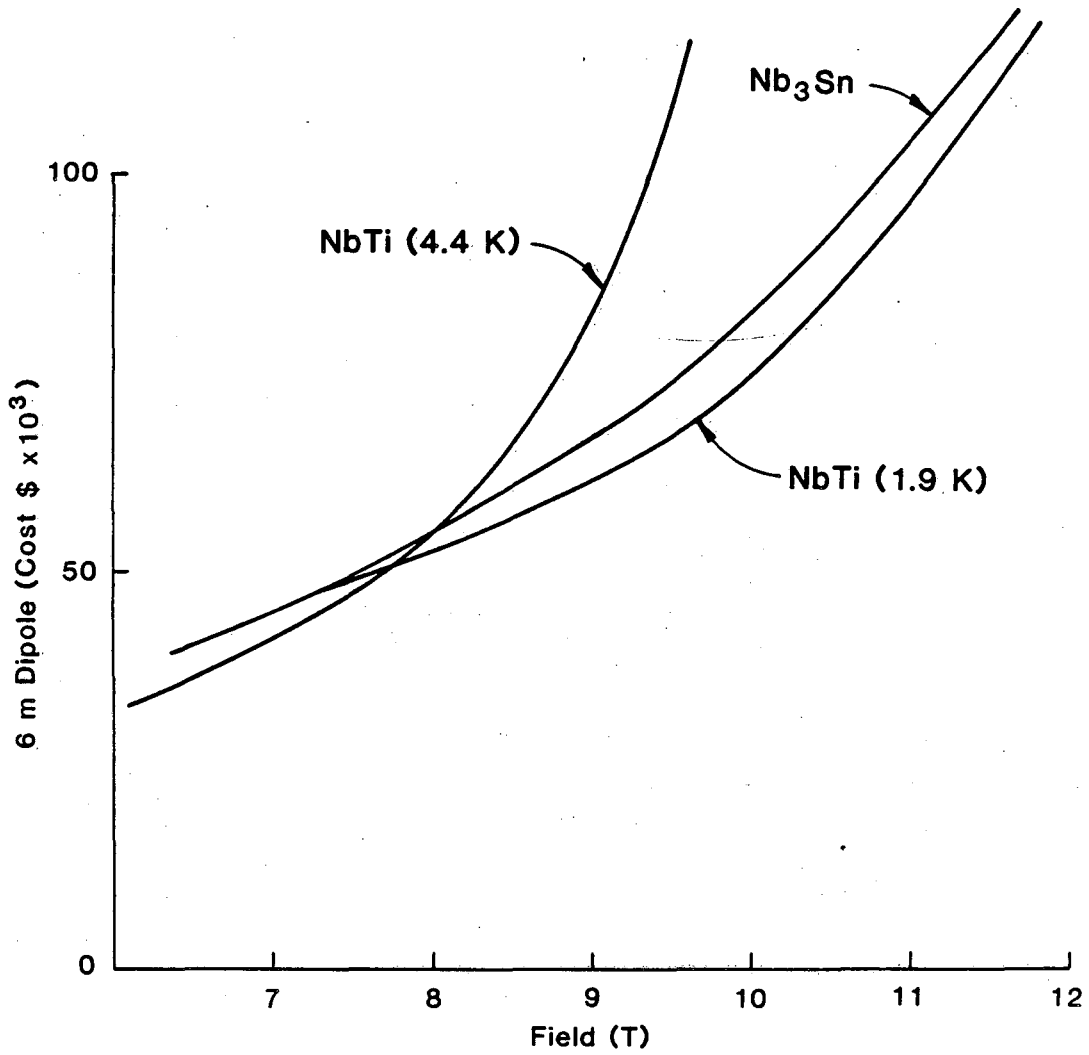

XBL 8210-3089

Fig. 10. Total Cost of 6-m Long Dipole Magnets Including the Differential Operating Costs for the Entire Life of 1.9K Nb-Ti Magnets

UNIT COSTS OF ACCELERATOR DIPOLES

The coil costs given above provide a comparison between different materials at the same field. Another way to compare these magnets is based on the bending power, which is the cost in units (\$/Teslameter). In this form a comparison can be made from one field to another not just from one material to another. The unit cost of magnets on this basis are given in Table XVI and Fig. 11. The minimum magnet costs are at the lowest fields, but the increased costs of land, trenching or tunneling, piping services, concrete, etc., should more than offset this effect.

Table XVI

Unit Costs of Accelerator Magnets in \$/Tm.

	Nb-Ti 4.4 K	Nb-Ti 1.9 K	Nb ₃ Sn 4.4 K
5	940	-	-
7	991	-	-
8	1127	1097	1142
9	1534	1140	1233
10	-	1248	1372
11	-	1452	1565

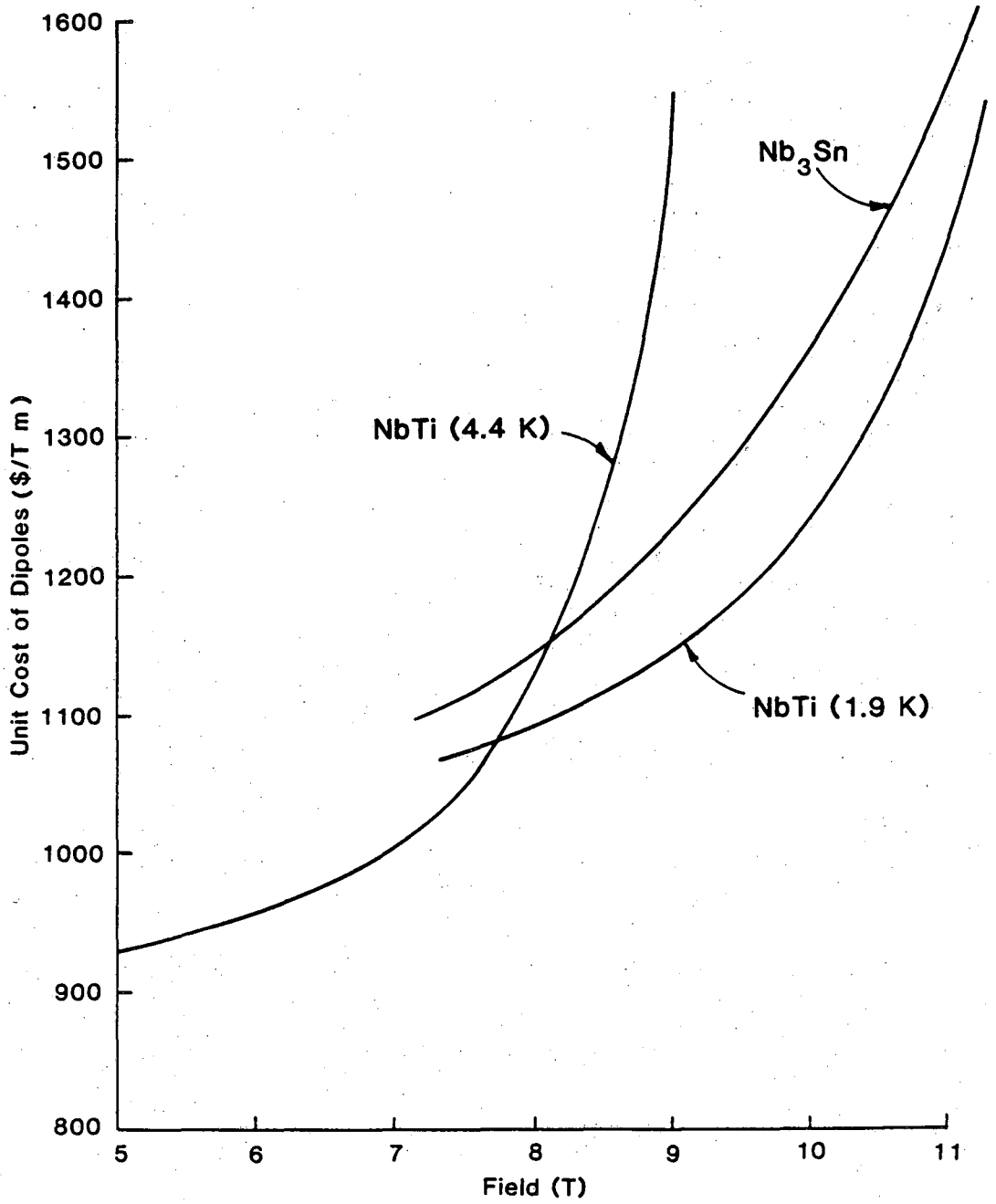

XBL 8210-3090

Fig. 11. Unit Cost of Accelerator Dipoles as a Function of Field

References

1. E. Adam, E. Gregory, D. Koop, and W. Marancik, "Practical Superconductors for High Energy Physics Magnets," IEEE Trans. on Nucl. Science, Vol. NS-28, No. 3, 3286, 1981, and private communication E. Adam, Mar. 1982
2. Private Communication - R. Lundy, Fermilab, Mar. 1981.
3. Private Communication - John Alcorn, General Atomic Corp., San Diego, CA.
4. D. C. Larbelestier, "Niobium Titanium Superconducting Materials," in Superconductor Material Science, S. Foner and B. Schwartz ed., Plenum Press, New York, 1981.
5. H. Hirabayashi, "8-10 T Dipole Magnets at KEK," paper from the ICFA Workshop IHEP, Serpukhov (1981).
6. E. Gregory, E. Adam, W. Marancik, S. Richards, and P. Sanger, Quantity Production of Multifilamentary Nb₃Sn Superconductors for Small and Large Applications Presented at ICEC 9, Kobe, Japan, 1982.
7. M. Hony, I. W. Wu, J. W. Morris, Jr., W. Gilbert, W. V. Hassenzahl, and C. Taylor, "An Investigation for the Enhancement of the Critical Current in Bronze-Procured Nb₃Sn, Adv. in Cryo. Eng. Mat., Vol. 28, 435-444, 1981.
8. R. B. Meuser, Magnetic Shields for Superconducting Bending and Quadrupole Magnets, LBL Report UCRL-18318, June 1968.
9. Robert B. Palmer, J. Gary Cottingham, Richard C. Fernow, Carl L. Goodzeit, Eugene R. Kelly, Mordechai Montag, Joseph Pasciak, Serban D. Protopopescu, David C. Rahm, William, Ralph P. Shutt, Alan J. Stevens, Iuliu Stumer and Donald Tuttle, "The Two Layer Isabelle Cable Magnet - Description and Test Results," BNL Internal Report, September 1981.
10. A Report on the Design of the Fermi National Accelerator Laboratory Superconducting Accelerator, Fermilab Report, May 1979, Editors - F. T. Cole, M. B. Donaldson, D. A. Edwards, H. T. Edwards, and P. F. M. Kochler.

This report was done with support from the Department of Energy. Any conclusions or opinions expressed in this report represent solely those of the author(s) and not necessarily those of The Regents of the University of California, the Lawrence Berkeley Laboratory or the Department of Energy.

Reference to a company or product name does not imply approval or recommendation of the product by the University of California or the U.S. Department of Energy to the exclusion of others that may be suitable.

TECHNICAL INFORMATION DEPARTMENT
LAWRENCE BERKELEY LABORATORY
UNIVERSITY OF CALIFORNIA
BERKELEY, CALIFORNIA 94720