

Lawrence Berkeley National Laboratory

Recent Work

Title

STOP THE DRAFT, INCREASE COMFORT AND SAVE ENERGY BY
TIGHTENING UP YOUR HOUSE

Permalink

<https://escholarship.org/uc/item/0w86q7pj>

Author

Diamond, R.C.

Publication Date

1978-11-01

STOP THE DRAFT

Increase comfort
and save
energy by
tightening
up your house

RECEIVED
LAWRENCE
BERKELEY LABORATORY

FEB 27 1979

LIBRARY AND
DOCUMENTS SECTION

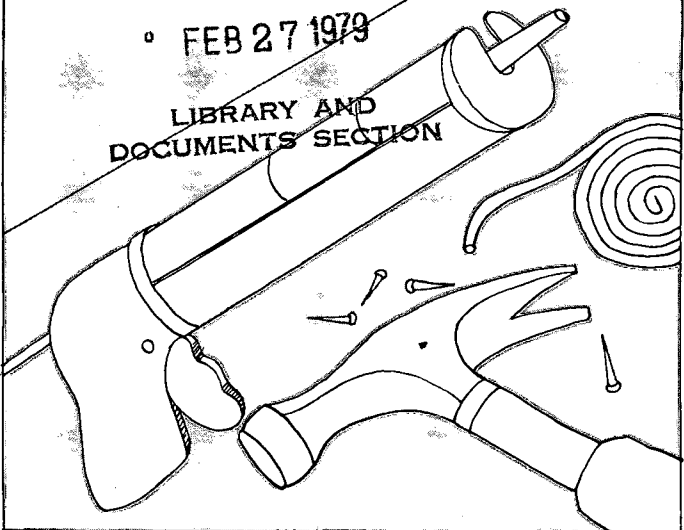

PUB 266 C.1

DISCLAIMER

This document was prepared as an account of work sponsored by the United States Government. While this document is believed to contain correct information, neither the United States Government nor any agency thereof, nor the Regents of the University of California, nor any of their employees, makes any warranty, express or implied, or assumes any legal responsibility for the accuracy, completeness, or usefulness of any information, apparatus, product, or process disclosed, or represents that its use would not infringe privately owned rights. Reference herein to any specific commercial product, process, or service by its trade name, trademark, manufacturer, or otherwise, does not necessarily constitute or imply its endorsement, recommendation, or favoring by the United States Government or any agency thereof, or the Regents of the University of California. The views and opinions of authors expressed herein do not necessarily state or reflect those of the United States Government or any agency thereof or the Regents of the University of California.

INTRODUCTION

Air infiltration, or air leakage, is the largest single component of your house's heating and air conditioning load; it may account for 1/3 to 1/2 of your winter heating and summer cooling bill. At a time when fuel prices are rising, this loss represents an unnecessary expense and a waste of our energy resources. Once you have identified the air leaks in your home, reducing air leakage is one of the cheapest and simplest energy conservation projects you can undertake.

This booklet will answer your questions on air leakage, telling you what you can do to upgrade your house, and describing step by step how to do it. Most of the steps are very inexpensive, and all of them are easy to do. They can be done safely, by someone with no previous experience in home repairs.

Do these steps before you insulate your house. Insulation is much more effective in a house that is well sealed against the weather. If you have already insulated your house, these steps will allow you to lower energy costs even more.

Major renovations done by a contractor should include the weatherstripping and caulking described here. Understand what is involved and get a commitment in writing to insure these steps are included.

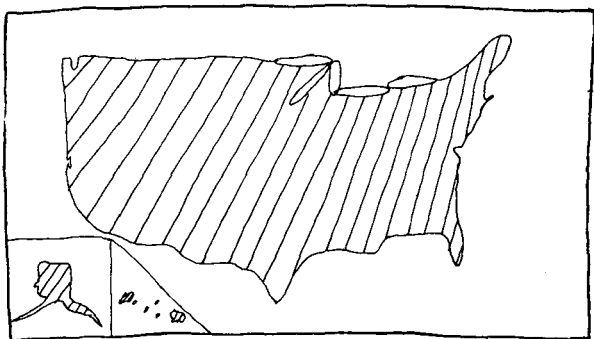

Homeowners in any part of the country can save energy. If you rent your house read the sections on finding the leaky areas and see if your landlord will do the repairs. Doing them yourself will lower your heating costs and increase the comfort of your home.

AIR LEAKAGE

INFILTRATION Infiltration is the uncontrolled leakage of outside air coming into your house. Air enters through cracks and bad joints in the exterior walls of the building — around doors, windows, chimneys, or any other opening.

VENTILATION Ventilation is the controlled exchange of air necessary for providing fresh air, combustion air for furnace systems, and for removing odors from household activities, including cooking.

What Causes Air Leakage

WEATHER Weather influences air leakage in two ways. First, wind blowing directly on a wall forces air into the house through any available opening, while on other walls, warm air is sucked out of the house. Second, because of temperature differences between the inside and outside, buoyant warm air rises to the top of the building, escapes, and is replaced by cold incoming air.

PEOPLE People cause air leakage by opening windows and doors, and by operating ventilating fans in kitchens, bathrooms, and laundry rooms. Everyone in the house should recognize that these activities cause heat loss.

How Air Leakage Affects Your House

HEAT LOSS Air leakage is a burden on your furnace. Whenever warm air escapes, it is replaced by cold outside air which must be heated. In most houses, the entire volume of air in the house is exchanged every hour, requiring the furnace to run far more often than if the air leakage were reduced.

HUMIDITY When leaks are reduced, dry cold winter air is kept out, and you can maintain a comfortable relative humidity inside the house without using a humidifier.

MOISTURE

Bathing, washing, cooking, house plants, and normal respiration and perspiration produce moisture inside your house, keeping a comfortable humidity level in the winter. After being tightened up, your house will have increased moisture levels. If this bothers you, simply running any exhaust fan or opening a window for a short time should clear up the problem. It is unlikely that any of the simple measures described here will result in high moisture levels.

Save Money

The simple measures described here are good investments, with initial costs returned in a few years, through lower fuel bills.

Comfort

A sealed house is a more comfortable home. Keeping the cold air out will result in fewer drafts and cold wall surfaces, and higher indoor relative humidity.

Energy Conservation

With a well-sealed house, you can lower your thermostat without decreasing comfort, which gives extra energy savings. If you are considering using solar energy, sealing air leaks is the necessary first step; it decreases fuel needs, which lowers the size and cost of a solar system.

KNOW YOUR HOUSE

First:

- ❑ Do a quick check of your house, making a list of the obvious leaks.
- ❑ Fix broken windows; don't forget basement windows.
- ❑ Check fireplace damper and make sure it is closed. Remember to open it before you use the fireplace. A pocket mirror held at an angle is an easy way of seeing the damper.
- ❑ See that the basement and attic doors are kept tightly closed. Leaving the basement door open creates a large updraft throughout the house.
- ❑ Pull drapes at night to cut down on drafts.
- ❑ Keep the track of sliding glass doors clean. Dirt here can throw the doors out of alignment, causing air leakage.
- ❑ Teach your children the need for keeping doors and windows closed when you are heating or air conditioning your home.

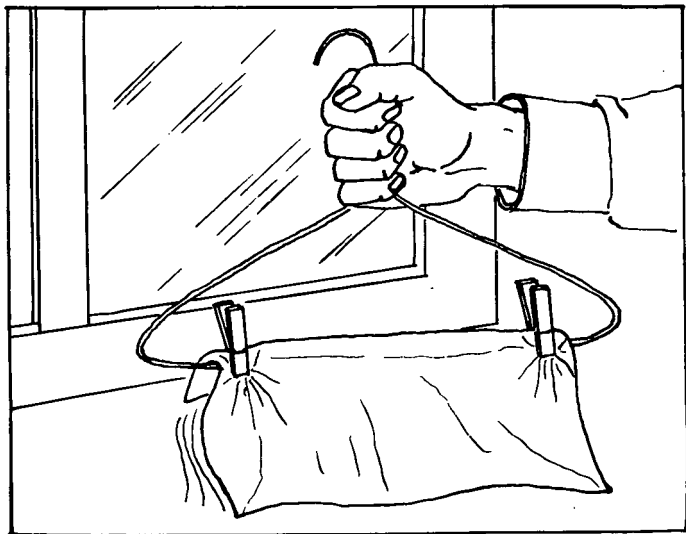

A hand made draft gauge can find many leaky areas. (Canadian Dept. of Energy Mines and Resources)

Then:

Make a thorough inspection of your house, looking for the small leaks. Air can enter through any crack or space; to effectively keep the heat in you will have to seal many small cracks. Keep a list of all cracks and leaks you find, so you can caulk and repair these areas later. *There are pages for this at the back of the booklet.*

How To Look

- DRAFT GAUGE** On a cold windy day you will be able to find many leaks by feeling with your hand. You can make a simple leak detector by clipping a piece of tissue paper or light plastic to a coat hanger. Hold the coat hanger in front of a suspected crack and any movement of the paper will indicate air leakage.
- SMOKE TESTS** You can also hold a lighted match up to the crack to see if air is leaking in, or use the smoke from a candle or cigarette to see air currents. Take care when using candles or matches, especially near flammable materials such as curtains.

Where To Look

- WINDOWS AND DOORS** Check how tightly windows and doors seal when closed. Inspect the framing of the window: frames often shift, leaving cracks between the frame and the wall.
- PIPES AND WIRES** Check holes cut into the walls for pipes or electrical wiring. Pipes under sinks in kitchens and bathrooms are often poorly sealed into the floor or wall.
- ELECTRICAL OUTLETS** Hold your draft gauge up to electrical wall outlets to test for leakage. Remember these outlets are just holes cut into the walls, and are seldom sealed.
- FOUNDATION SEAL** A major leakage area is around the foundation seal. Wherever different materials come together, they can shrink and pull apart, causing leaks.
- MAIL CHUTES** Don't overlook a mail chute in your front

door. If the flap doesn't close tightly, a lot of cold air can be entering the house. A little oil on the hinges can help.

FIREPLACES

Fireplaces not only lose heat up the chimney, but also have cracks where the masonry meets the wall. A wood panel across the opening will reduce air leakage when the fireplace is not in use.

EXHAUST FANS

Exhaust fans in the kitchen and bathroom should be sealed into the wall or ceiling. Make sure the filter in your kitchen fan is kept clean, so odors and smoke move out more quickly and you can turn off the fan sooner. Use fans only when necessary, as they quickly vent heated or cooled air out of your house.

ATTICS

Even if your attic is insulated, it is especially important to check for all leaks here. Holes in the ceiling from pipes and electrical wires should be sealed. When working in the attic, use a board placed across the stringers so you won't fall through the ceiling.

GARAGE DOORS

Attached garages act as a buffer in keeping air from leaking into the house. Garage doors, however, are often quite leaky. Check to see if the bottom edge is adequately weatherstripped, and that it seals tightly.

SIDING CRACKS

Split and broken siding will eventually cause substantial air leakage. Damaged siding should be replaced; small cracks can be nailed closed.

MASONRY CRACKS

Mortar joints in masonry walls deteriorate with age. While the weight of the masonry itself is usually sufficient to seal small cracks, some gaps may require caulking.

OLD CAULK AND WEATHER- STRIPPING

All caulk and weatherstripping should be inspected. Even though most weatherstripping materials last many years, it is important to keep them in good shape.

CHECK LIST OF HOUSE LEAKS

Starting at the basement of your house and working your way up, don't overlook the following areas:

- Basement windows
- Basement ceiling—holes cut for wires and plumbing
- Basement door/crawlspace access door
- Heating ducts in crawl space
- Exterior lights, electrical outlets, and water pipes
- Windows—sashes, frames, and trim
- Doors—mail slots and glass panels
- Sliding glass doors
- Fireplaces, dampers
- Electrical wall outlets
- Attic floors—holes cut for wires and plumbing

WHAT TO DO

Caulking and weatherstripping, which are easy and inexpensive, will effectively seal most leaks. However, it must be done carefully to insure good performance.

Caulking

Caulk is a versatile sealant which can be used to seal almost any crack or small opening. There are dozens of caulking materials you can choose from. They differ in durability, adhesion, shrinkage and, naturally, cost.

All caulk can be applied with a caulking gun (using disposable cartridges), or with a putty knife. The caulking gun costs a few dollars and lasts for years. Knife-grade caulk, applied with a putty knife, is used for wide cracks.

Table of Caulking Materials

Oil base	the standard all purpose caulk, can be used on almost any surface, is inexpensive, but will shrink and harden with time.
Latex	a fast drying water based caulk which is durable, cleans up easily, and has little shrinkage.
Silicone	more expensive, and will last for many years. Can be used on most surfaces, but cannot be painted over.
Butyl rubber	used mainly between metal and brick or stone. Fairly expensive, it will last for years.
Polyvinyl acetate	fairly inexpensive, and can be used on any surface.

Where to Caulk:

Use a solvent or a small chisel to free area to be caulked of dirt, loose paint, and deteriorated caulk.

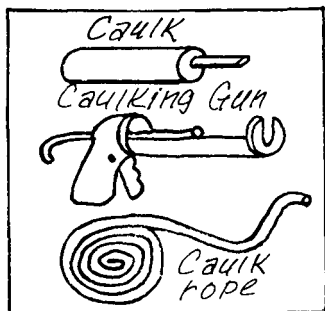

Caulking Materials

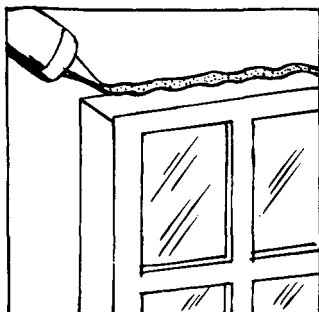

Around Windows

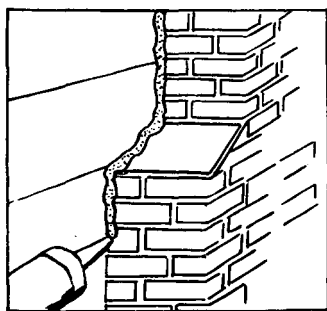

*Where Two Different
Materials Join*

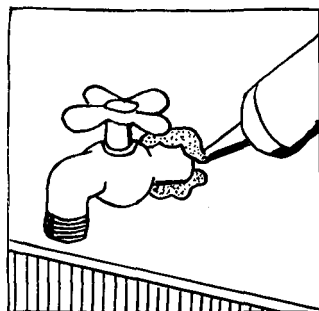

Outside Water Faucets

Weatherstripping

Weatherstripping is applied around doors and the moveable parts of windows to insure a good seal. A self adhesive pliable gasket weatherstripping is available that is easily applied to basement windows. When installing the spring metal type, care must be taken not to crush or damage the piece. Work slowly and replace damaged pieces. The drawings indicate where to install the weatherstripping; follow the manufacturer's directions for complete installation.

Types of Weatherstripping

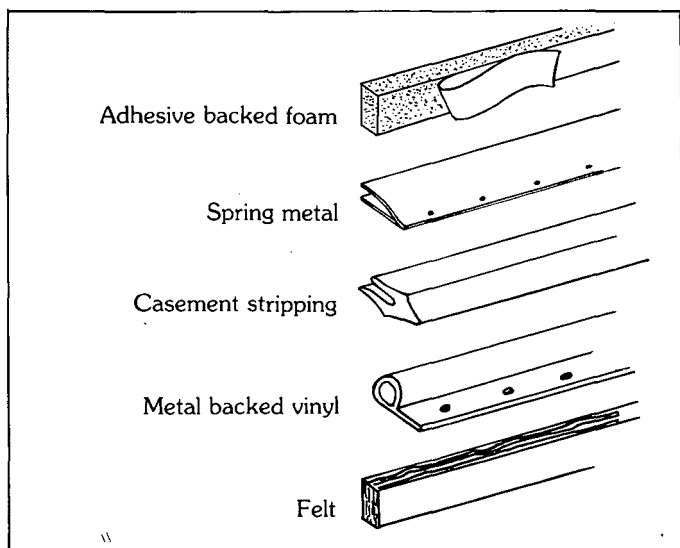

Weatherstripping windows:

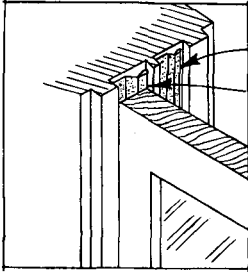

Double Hung

Spring metal
in track for
Upper and
Lower Sash

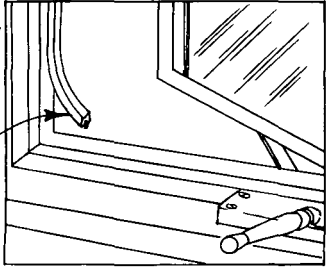

Casement

Vinyl
Gasket

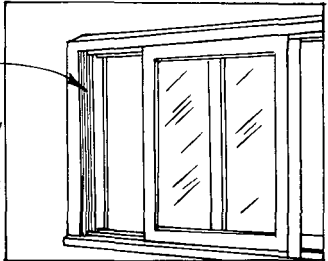
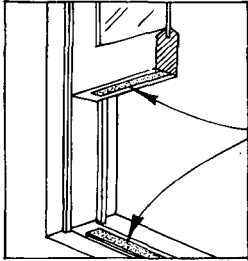

Sliding Window

Spring
metal

Felt or foam
applied to
top of sill,
or underside
of sash

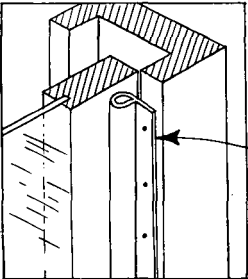

Vinyl
tubing

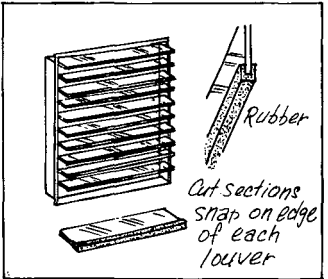

Loured Window

Rubber

cut sections
snap on edge
of each
louver

Weatherstripping doors:

Weatherstripping materials for doors are similar to those used for windows. Spring metal is perhaps the easiest to use. Special weatherstripping is used for thresholds between door and floor, and for garage doors. Illustrations show these different types.

Before weatherstripping your doors, it is important that they fit properly in their frame, without binding or sticking. So the first step is often truing the door. If the door sticks at top or bottom you must plane or sand the sticking edge. If the door binds or sags, the hinges may have worked loose, or the frame may have shifted.

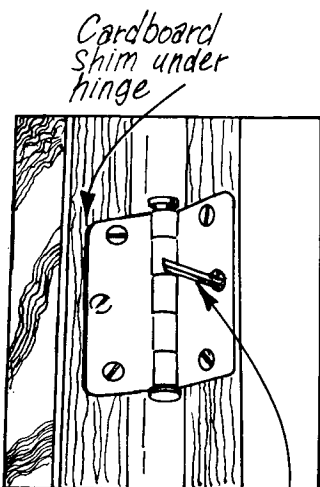

To correct loose door hinges, remove the door and fill the worn screw holes with match sticks dipped in glue, or with steel wool. Replace the screws, and then the hinge should fit tightly.

If the door still binds, use shims of cardboard under the hinge to allow the door to close.

DOOR TOP VIEWS

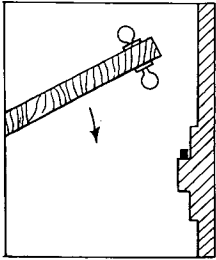

*Adhesive Backed
Foam*

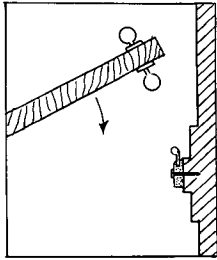

*Rolled Vinyl with
Metal Backing*

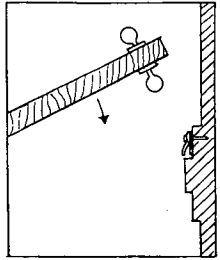

Spring Metal

DOOR SIDE VIEWS

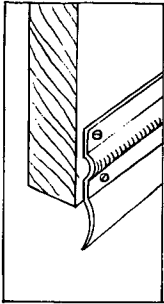

Sweeps

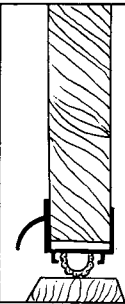

Door Shoe

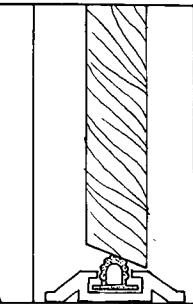

*Vinyl Bulb
Threshold*

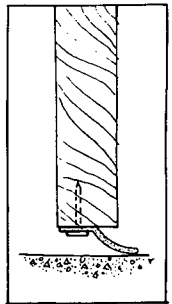

Garage Doors

Storm Windows and Doors

You can make your own storm windows with inexpensive plastic sheet and wood molding, or you can buy ready made glass windows at a building supply store.

Plastic storm windows are more effective when placed on the outside of the window, but they can also be placed inside, where they are simpler to install and protected from the weather.

To make plastic storm windows for the outside, measure around the frame and buy the right length of $\frac{1}{2}$ -inch wooden molding. Place the plastic over the window frame, then tack the molding to hold it in place. Caulk all the way around the edge of the molding to make a good seal. A staple gun is an inexpensive and useful tool for tacking (see illustration). Making frames for outside plastic windows is usually not worth the extra effort. Since the plastic degrades, it is unusable after a few winters anyway.

To make a plastic storm window for the inside of your window, cut a large enough piece of plastic (6 mil polyethylene is sufficient) to fit over the window frame, and use a good quality masking tape or magic tape to seal it in place. Keeping the tape out of direct sunlight will make it easier to remove later.

Storm windows are not easy to make, but they are readily available at building supply stores. An outside screen door can, however, be covered with polyethylene to make a storm door.

Storm windows:

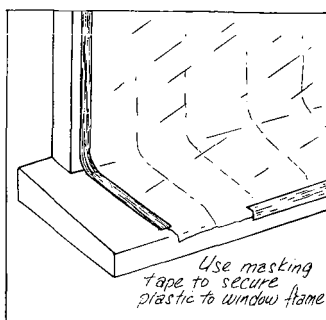
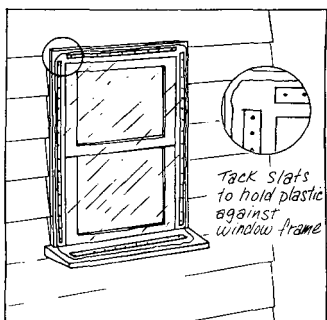

Other Measures

HEATING DUCTS

Ducts might not be easily accessible, and are a frequently overlooked source of heat loss. If your heating ducts pass through unoccupied spaces, like attics or crawlspaces, they should be well sealed with duct tape, and then wrapped with a batt of insulation.

WINDBREAKS

Fences, hedges, trees, garages, or sheds placed on the windward side of the house reduce the pressure distribution which is a driving force for air leakage. An effective barrier can reduce air leakage by as much as 45%.

VESTIBULES

Building a vestibule as an entranceway is very effective in reducing drafts around exterior doors. Common in Scandinavia and other northern regions, the vestibule acts as a buffer zone or air lock, reducing the outdoor air entering each time the door is used. A vestibule can be twice as effective as storm doors.

Windbreakers:

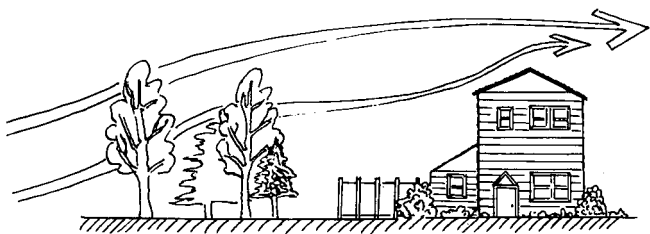

Trees, plantings, fences, and garages all block the wind from your house.

Seasonal House Check

These measures are not a one-time project—your house is constantly changing, weather effects and small shifts in the house are always opening new cracks and leaks.

Twice a year go over your entire house, inspecting all the potentially leaky areas. In the fall, make sure everything is well sealed before the winter heating season. In the spring it is important to look for damage done by winter weather.

In the fall:

Inspect all windows and doors to make sure caulking and weatherstripping are in good condition. If caulk has dried and cracked it should be scraped clean and redone. Weatherstripping should seal tightly against moving parts. Look for damaged or bent sections which need to be replaced. Remember, these are inexpensive materials which are effective only when well maintained.

Check and see that the fireplace damper hinge is operable and that the damper will close tightly when the fireplace is not in use.

Replace filter in furnace several times during the operating season to allow heating system to operate more efficiently. This is important in realizing the benefits of a comfortably sealed house.

In the spring:

Inspect windows and doors again for damaged caulk and weatherstripping and replace where necessary. It is important to keep an air-conditioned house well sealed against moisture-laden air during the summer months.

Plant shrubs, hedges, or trees to act as a windbreak and shelter the house in the winter.

RESEARCH

Researchers are measuring air leakage rates in typical residential houses in several parts of the country, using tracer gas techniques and pressurization tests.

GOALS

The goals of these studies are to determine the effects of various measures in stopping air leakage, and to establish new standards for comfortable, energy-efficient houses.

HEAT EXCHANGERS

Residential air-to-air heat exchangers are a promising development. These small, low-cost devices, now available in Japan and Northern Europe, allow a continuous supply of fresh outdoor air to enter the house. This air is preheated by warm air exhausted from the home. The high efficiency of the heat exchangers is realized only if the house is well sealed against air leakage.

Heat Exchanger:

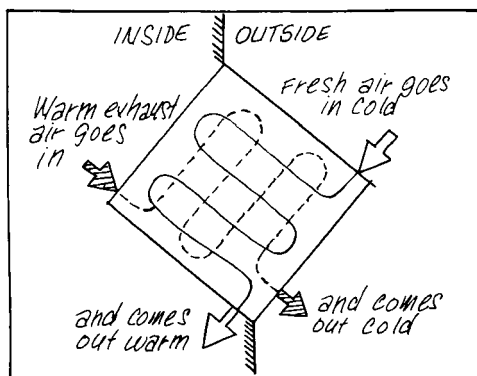

Heat exchangers can take as much as 90% of the heat from the exhaust air and transfer it to the fresh air.

ADDITIONAL READING

These books contain additional information. Check with the publisher for current prices.

Adams, Anthony, *Your Energy Efficient House*, Garden Way Publishing, Charlotte, VT. 05445 (1975) \$4.95.

American Institute of Architects Research Corp., *Energy Conservation in Building Design*, 1735 New York Ave. N.W., Washington, D.C. 20006 (1976).

Barnaby, C.S., Caeser, P., and Wilcox, B., *Solar for your Present Home*, California Energy Commission, 1111 Howe Ave., Sacramento, CA 95285 (1978).

Clegg, Peter, *New Low-Cost Sources of Energy for the Home*, Garden Way Publishing, Charlotte, VT. 05445 (1975) \$5.95.

Derven, Ronald and Nichols, Carol, *Cut Your Energy Bills*, Structures Publishing Co., P.O. Box 423, Farmington, MI. 48024 (1976) \$4.95.

Energy, Mines, and Resources, Canadian Dept. of, *Keeping the Heat In*, P.O. Box 900 Westmount Postal Station, Montreal, Quebec, Canada H322V1 (1976).

Housing and Urban Development, U.S. Department of, *In the Bank . . . or Up the Chimney*, GPO, Washington, D.C. 20402 (1975) \$1.70.

Leckie, Jim, et al., *Other Homes and Garbage*, Sierra Club Books, 530 Bush St., San Francisco, CA. 94108 (1975) \$9.95.

Murphy, J.A., *Homeowner's Guide to Saving Energy*. Thomas Y. Crowell Company, 666 Fifth Ave., New York, NY 10019 (1976) \$6.95.

Nunn, Richard V. *Saving Home Energy*, Oxmoor House, P. O. Box C-59, Birmingham, AL 35283 (1975) \$1.95.

Price, B.L. and Price. T.P., *Homeowner's Guide to Saving Energy*, Tab Books, Blue Ridge Summit, PA 17214 (1976) \$5.95.

Time-Life, *Weatherproofing*, Time-Life Books, Alexandria, VA. (1977).

REPAIRS TO BE MADE

1. _____

2. _____

3. _____

4. _____

5. _____

6. _____

7. _____

8. _____

9. _____

10. _____

11. _____

12. _____

13. _____

14. _____

15. _____

16. _____

17. _____

18. _____

19. _____

20. _____

21. _____

22. _____

23. _____

24. _____

25. _____

Address all inquiries to the author:

Richard C. Diamond
Building 90, Room 3078
Lawrence Berkeley Laboratory
University of California
Berkeley, California 94720

For Reference

Not to be taken from this room

LEGAL NOTICE

This report was prepared as an account of work sponsored by the United States Government. Neither the United States nor the United States Department of Energy, nor any of their employees, nor any of their contractors, subcontractors, or their employees, makes any warranty, express or implied, or assumes any legal liability or responsibility for the accuracy, completeness or usefulness of any information, apparatus, product or process disclosed, or represents that its use would not infringe privately owned rights.



Lawrence Berkeley Laboratory
University of California
Berkeley, California 94720

Prepared for the U.S. Department of Energy under Contract W-7405-ENG-48

Technical Information Department/Pub. 266 5M/Nov. 1978