

# UC Riverside

## UC Riverside Previously Published Works

### Title

Machine Learning-Based Error Correction Codes and Communication Protocols for Power Line Communication: An Overview

### Permalink

<https://escholarship.org/uc/item/0xv3t2xd>

### Authors

Akinci, Tahir Cetin

Erdemir, Gokhan

Zengin, A Tarik

et al.

### Publication Date

2023

### DOI

10.1109/access.2023.3330690

### Copyright Information

This work is made available under the terms of a Creative Commons Attribution-NonCommercial-NoDerivatives License, available at

<https://creativecommons.org/licenses/by-nc-nd/4.0/>

Peer reviewed

## TOPICAL REVIEW

# Machine Learning-Based Error Correction Codes and Communication Protocols for Power Line Communication: An Overview

**TAHIR CETIN AKINCI**<sup>1,2</sup>, (Senior Member, IEEE),  
**GOKHAN ERDEMIR**<sup>3</sup>, (Senior Member, IEEE), **A. TARIK ZENGİN**<sup>2</sup>,  
**SERHAT SEKER**<sup>2</sup>, AND **ABDOULKADER IBRAHIM IDRİSS**<sup>4</sup>

<sup>1</sup>WCGEC, University of California at Riverside (UCR), Riverside, CA 92521, USA

<sup>2</sup>Electrical Engineering Department, Istanbul Technical University (ITU), 344690 İstanbul, Turkey

<sup>3</sup>Engineering Management and Technology, The University of Tennessee at Chattanooga, Chattanooga, TN 37403, USA

<sup>4</sup>Department of Electrical and Energy Engineering, Faculty of Engineering, Université de Djibouti, Djibouti City, Djibouti

Corresponding author: Tahir Cetin Akinci (tahircetin.akinci@ucr.edu)

**ABSTRACT** This study endeavors to investigate the effectiveness of machine learning-based methodologies in enhancing the performance and reliability of Power Line Communication (PLC) systems. PLC systems constitute a critical component within the domains of energy management, monitoring, and automation. The fundamental objective herein is to contribute significantly to the scholarly discourse by conducting a comprehensive review encompassing research investigations and practical applications documented in the extant literature. The primary motivation underpinning this research is predicated upon the necessity for a meticulous evaluation of machine learning techniques that hold the potential to enhance the efficacy and stability of PLC systems. The deployment of these techniques bears the promise of engendering heightened levels of efficiency across the spectrum of energy management, communication, and automation systems. Within this scholarly quest, the study posits a hypothesis: Machine learning-based methodologies possess the capacity to effect marked improvements in the performance and reliability of PLC systems. Methodological scrutiny is executed through a comprehensive evaluation of diverse machine learning techniques, including, but not limited to, deep learning, support vector machines, and random forests, facilitated by a series of empirical experiments and simulations. Empirical findings resoundingly corroborate the proposition, substantiating a significant enhancement in the operational performance of PLC systems when these machine learning methods are judiciously employed. In summation, this study assumes the role of a catalyst in exploring latent, untapped potential inherent within machine learning-based methodologies, customarily calibrated to resonate within the intricate matrix of PLC systems. The zenith of this rigorous investigation stands poised to illuminate the path toward transformative advancements in the domains of energy management, communication, monitoring, and automation systems. The findings contribute significantly to the academic discourse, offering a compass for future research inquiries and practical applications within this burgeoning and dynamic field.

**INDEX TERMS** Power line communication, error correction codes, machine learning, transmission control protocols, communication protocols, power networks.

## I. INTRODUCTION

The Power Line Communication (PLC) technology offers a reliable and cost-effective communication solution for

The associate editor coordinating the review of this manuscript and approving it for publication was Oussama Habachi<sup>1</sup>.

various applications such as Smart Buildings, Smart Cities, and Industry 4.0 [1], [2]. The broadband PLC technology development enables higher data rates and supports more protocols used in Smart Building applications [3], [4]. This technology is especially suitable for continuous power quality monitoring, electric vehicle charging, and microgrid

and distribution generation applications. The deployment of Broadband Over Power Lines (BPL) networks is expected to keep growing due to the increasing demand for energy efficiency and emissions reduction [5], [6].

PLC technology is a method to utilize electrical power transmission lines as a medium to convey data through a conductor [7]. This technology is known by various nomenclatures, including Power Line Server (PLS), Power Line Digital Subscriber Line (PDSL), grid communication, power line telecommunications (PLT), Power Line Network (PLN), or Broadband Over Power Lines (BPL). Electric power transmission occurs over high-voltage transmission lines, is subsequently distributed over medium-voltage lines, and is ultimately utilized within buildings at lower voltage levels. PLC systems can seamlessly transition between two distinct levels, such as the distribution network and plant cabling, albeit each PLC technology is constrained to a particular set of cables. To accommodate the creation of expansive networks, it is possible to amalgamate multiple PLC technologies, as the transmission of signals can be interrupted by transformers [8], [9].

Power networks are categorized into three types: DC sources used in industrial applications such as automotive, sinusoidal supply used for electrical distribution networks or domestic applications [10], and expansion units containing

converters and actuators pulse width modulated (PWM) networks [11], [12].

PLC technology is often used over sinusoidal and continuous electrical networks, guaranteeing several hundred megabit data rates. However, PLC modems cannot operate in PWM networks due to their wide spectral occupancy [13]. New PLC modems are deployed specifically for PWM networks based on a comprehensive review of the inverter spectrum. These modems achieve reliability and data rate capacity values. This technology eliminates additional cable length between the actuator and transducers, resulting in cost and size advantages.

**A. POWER LINE COMMUNICATION**

PLC technology enables data communication over the electrical grid [14]. This technology is an alternative solution to wireless or wired networks, particularly in indoor environments. PLC utilizes frequency ranges in the power grid to facilitate data transmission and can be used for various applications such as internet connectivity, IPTV, smart metering devices, smart home systems, and industrial automation [15], [16], [17].

PLC is widely used in many fields due to its communication quality, speed, cost, and ease of installation advantages. However, noise and signal distortions in the power grid

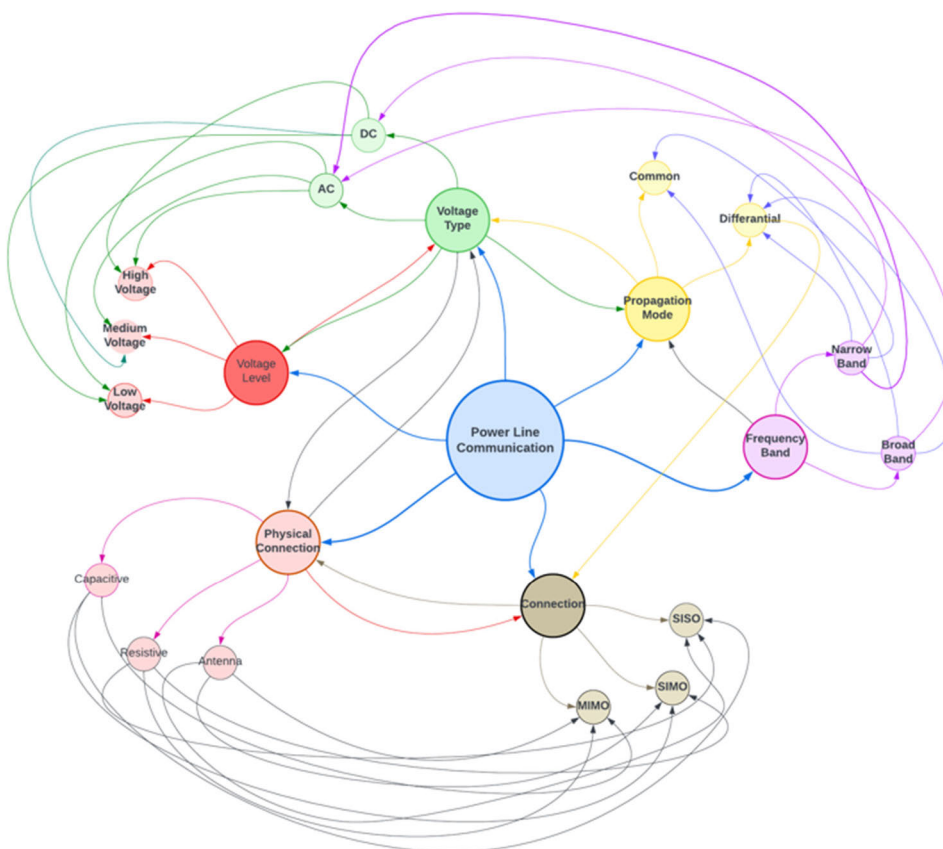

**FIGURE 1.** Categorization and network visualization of PLC system.

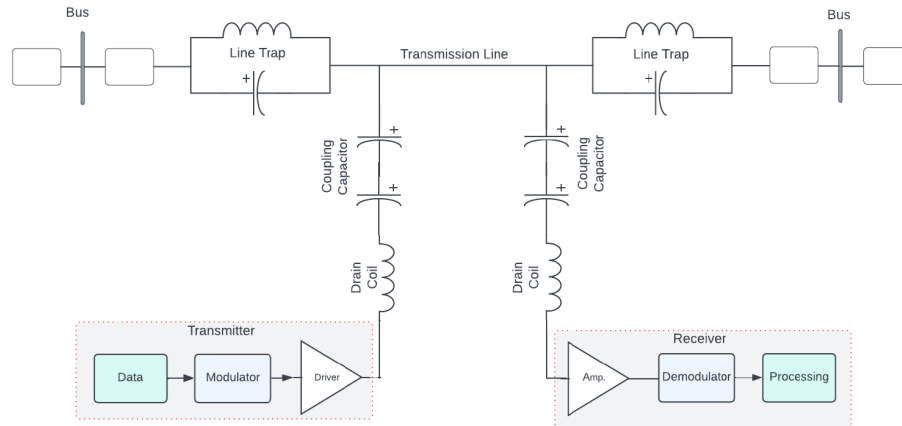

FIGURE 2. Essential components of a PLC system [23], [24].

can impact the communication quality of PLC [18], [19]. Different techniques are employed for the development and improvement of PLC. These techniques include error correction codes, artificial neural networks, deep learning, support vector machines, and random forests, among other machine learning-based methods.

PLC technology may find broader applications in the future, particularly in areas such as smart cities, intelligent transportation systems, and renewable energy [20].

In PLC systems, coupling plays a crucial role in PLC, and it is expected to be more involved in the next generation of PLC. The performance evaluation of PLC primarily focuses on how the Connectivity Unit (CU) is designed, interfaced, and connected to the Power Grid and its performance in a boisterous environment. In the literature, PLC couplers are classified based on six criteria: (1) Physical connection, (2) Voltage level, (3) Voltage type, (4) propagation mode, (5) frequency band, and (6) number of connections. Figure 1 illustrates the different types of PLC in each category. The physical link mentioned here involves integrating, injecting, and extracting the communication signals to and from the power line. Consequently, to establish a connection with the line, there are four ways of physical configuration: antenna, resistive, inductive, and capacitive [21], [22].

The schematic representation of a PLC network used in an electrical power system is shown in Figure 2 [23]. The power transmission line, Transmitter, and Receiver components are depicted here. PLC is a communication method that utilizes the existing electrical power infrastructure to transmit data from the sender to the receiver. The system operates in full duplex mode and consists of three fundamental parts. A component called “wave-trap” or “line-trap” is used in this system to prevent communication signals from entering the equipment through the power supply line and to allow signal division. This component provides high series impedance to the carriers’ frequencies, comprising different resonant circuits that block all communication currents while allowing

power frequency to pass. This system is also referred to as a connection element.

- *Terminal Devices*: The terminal section encompasses the essential components of the PLC network. Transceivers and protective relays are used for initiating and directing communication. Transceivers facilitate the transfer of data between the sender and receiver. On the other hand, protective relays are employed to ensure network security and provide protection in case of line faults.
- *Connection Equipment*: The connection section provides the physical connections for the PLC communication network. The line adjuster ensures the transmission of communication signals onto the power line and adjusts the line parameters accordingly. The connection capacitor allows for the injection of communication signals onto the power line and their transmission to the receiver. Additionally, a combination of components such as wave traps or line traps aims to block undesired frequency components on the transmission line, enhancing communication quality and mitigating *disturbances*.
- *50/60 Hz Power Transmission Line*: This section forms the transmission path for the PLC communication network. Existing 50/60 Hz power transmission lines are utilized for data transfer across the PLC bandwidth. Communication signals are transmitted over and delivered through the power lines within the 50/60 Hz frequency range. Consequently, data transmission is achieved without a separate communication infrastructure [1], [14], [25], [26], [27]. PLC is a highly effective communication method employed in transformer stations, leveraging the existing power infrastructure to reduce costs [28].
- *Coupling Capacitor*: The coupling capacitor connects the transmission line and terminal devices, facilitating the transmission of carrier signals [28]. It is designed to exhibit high impedance at power frequencies and low impedance at carrier signal frequencies [29]. These equipment systems are typically constructed using paper

or liquid dielectric materials, primarily for high-voltage applications. The rating of coupling capacitors varies based on IEEE guidelines, ranging from 0.004-0.01  $\mu\text{F}$  at 34 kV to 0.0023-0.005  $\mu\text{F}$  at 765 kV [30].

- *Drain Battery*: Figure 2 illustrates the role of the discharge coil, which provides high impedance for carrier frequencies and low impedance for power frequencies.

The limitations of PLC are as follows:

1. *Infrastructure Constraints*: PLC is constrained by the characteristics of the existing electrical infrastructure [31], which introduces various factors that impact power line channel parameters, including power attenuation, noise, impedance, and bandwidth [32], [33].
2. *Signal-to-Noise Ratio Requirements*: PLC communication necessitates a high Signal-to-Noise Ratio (SNR) for effective data transmission [31]. This implies that a strong signal is required while minimizing unwanted noise to ensure reliable communication [34]. The design and planning of power lines could be more suitable for high-frequency signals. In electric power transmission lines, attenuation, multipath due to impedance mismatches, and noise are the three most essential degradation factors that degrade PLC performance [35]. Noise in PLC channels is generated by all electrical devices connected to the Quality, which is a parameter of the receiver's noise level and the electrical signal's attenuation at different frequencies. The higher the noise level, the more difficult it is to detect the received signal. Suppose the signal is attenuated on its way to the receiver. In that case, it can make the decision even more difficult as the signal is further obscured by noise, expressed as the signal-to-noise ratio (SNR) level. SNR measures how much a signal is degraded by noise (Equation 1) [35], [36].
 
$$SNR_{dB} = 10 \log_{10} \left( \frac{P_{signal}}{P_{noise}} \right) \quad (1)$$
3. *Unmatched Loads and Variability*: The power line network often encounters unmatched loads and exhibits temporal variations [37]. This can lead to power carrier attenuation, a significant drawback of PLC, affecting the quality and reliability of the communication [38], [39].
4. *Reflection Losses*: Carrier frequencies in PLC systems experience reflection losses at different points along the transmission path, such as from the transmitter, through the coaxial cable, the line adjuster unit, the coupling capacitor, and the power line. These losses can result in signal degradation, loss, and distortion during transmission [37], [38].
5. *Security Concerns*: PLC faces security challenges as the power line infrastructure is susceptible to external interference and electromagnetic disturbances. This vulnerability poses potential security risks, requiring appropriate measures to ensure data confidentiality and integrity [1].

These limitations underscore the disadvantages [31] and challenges associated with using PLC as a communication method over power lines [40], [41].

## B. ERROR CORRECTION CODES AND COMMUNICATION

Protocols are employed for detecting and correcting errors during data transmission, with error correction codes serving as a critical component in this process [42]. Erroneous data transmission can arise due to channel noise, interference, parasitic elements, electromagnetic interference, and various other environmental factors [43]. Error correction codes facilitate the rectification or retransmission of erroneous data packets by appending additional information (parity bits) to the transmitted data [44], [45]. Fundamental error correction codes encompass the following:

- a. *Hamming Codes*: Hamming codes provide single-error correction and double-error detection capabilities. These codes are used to correct errors at the bit level during data transmission [46].
- b. *Reed-Solomon Codes*: Reed-Solomon codes are block-based error correction codes that can correct multiple-bit errors. They are mainly employed in applications such as optical and magnetic storage devices, wireless communication systems, and digital television broadcasting [47], [48].
- c. *Turbo Codes and LDPC (Low-Density Parity-Check) Codes*: These codes offer higher error correction performance, enabling efficient and reliable communication. They are commonly utilized in space and satellite communication systems [49], [50].

The classification of forward error codes is given in Figure 3. Here, under Block Codes and Convolution Codes, a general category can be made as Hamming, Golay, BCH, Rs, LDPC, Trellis, and Turbo Codes [22], [51].

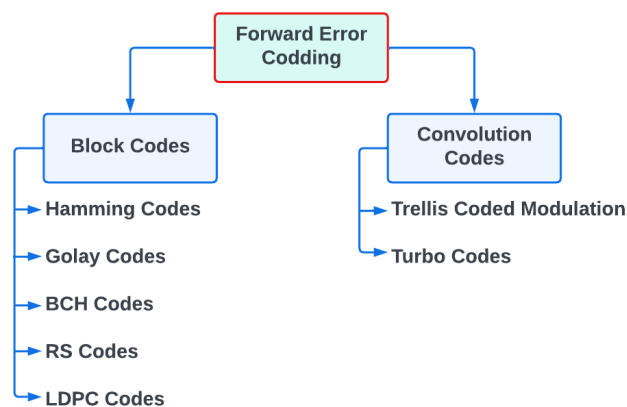

FIGURE 3. Classification of error coding [22], [51].

In addition to error correction codes, communication protocols are crucial in facilitating reliable and efficient data transmission. These protocols define the rules and procedures for communication, including data framing, error detection, flow control, and packet acknowledgment. Examples of

popular communication protocols include the Ethernet protocol, Wi-Fi protocols (e.g., IEEE 802.11 standards), and the Transmission Control Protocol/Internet Protocol (TCP/IP) suite [50], [51]. Error correction codes and communication protocols ensure accurate and robust data transmission in various applications [51].

Communication protocols facilitate synchronized and orderly data exchange among participants in data communication processes. These protocols define communication processes such as data formatting, timing, error control, and flow control. The main communication protocols include the followings:

- *TCP (Transmission Control Protocol)*: TCP is a reliable, connection-oriented protocol used for data transmission over the Internet. It provides error control and flow control mechanisms for ensuring proper delivery of data packets and retransmission of erroneous packets [50], [51].
- *UDP (User Datagram Protocol)*: UDP is a fast and lightweight communication protocol that operates connectionless. Unlike TCP, UDP does not provide error and flow control mechanisms, making it more prone to packet loss or errors. This protocol is suitable for real-time applications, video, and audio streaming [52].
- *IP (Internet Protocol)*: IP is a fundamental network protocol that enables routing of data packets from source to destination over a network. It works with TCP and UDP, operating at the network layer [53].
- *ARP (Address Resolution Protocol)*: ARP is a protocol that translates IP addresses at the network layer to physical addresses (MAC addresses) at the data link layer. This facilitates data transmission between devices on the network [54].
- *HTTP (Hypertext Transfer Protocol)*: HTTP is an application layer protocol that transmits web pages between web browsers and servers. It typically operates over TCP and can be used securely with the HTTPS (HTTP Secure) version [55], [56].
- *FTP (File Transfer Protocol)*: FTP is an application layer protocol used for file transfers. It provides a reliable and efficient method for uploading and downloading files between servers [57], [58].
- *MQTT (Message Queuing Telemetry Transport)*: MQTT is a lightweight and energy-efficient communication protocol designed specifically for Internet of Things (IoT) applications. MQTT enables message transmission with low bandwidth and power consumption between devices and servers [59], [60].

Error correction codes and communication protocols ensure data communication's reliability and performance [61]. A well-designed communication system utilizes effective error correction codes and protocols to correct errors and facilitate orderly and synchronized data exchange, leading to more reliable and efficient communication systems [62], [63].

The error correction analysis graph for a PLC model is given in Figure 4. Here, the Hamming (7,4) encoding matrix

is used to encode a 4-bit data string, the original data is represented by `input_data`, and the encoded data is obtained by multiplying the data with the encoding matrix and getting modulo 2.

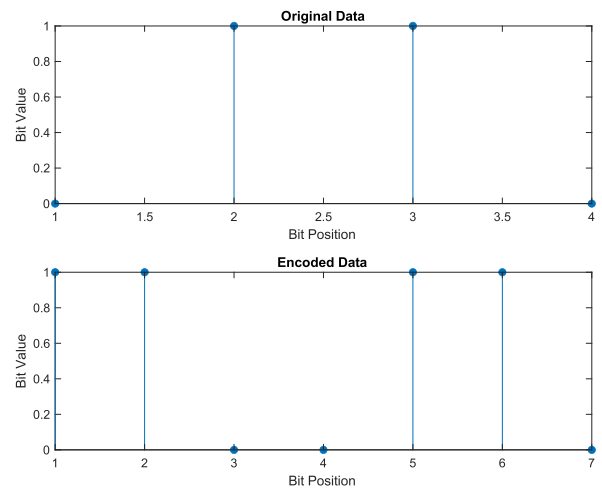

FIGURE 4. Error correction codes and communication.

The provided illustration serves as a fundamental demonstration of error-correcting code implementation. Real-world error correction codes and communication protocols exhibit greater intricacy, necessitating meticulous design and optimization tailored to precise requirements and application contexts.

### C. UTILIZATION OF MACHINE LEARNING-BASED METHODS

Machine learning (ML) is rapidly evolving as a significant tool in data analysis and pattern recognition [44]. In the field of communication systems, particularly in areas such as error correction codes and communication protocols, the utilization of machine learning-based methods has led to significant improvements [58], [59]. This section will discuss the impact and applications of machine learning-based methods on error correction codes and communication protocols.

*Machine Learning-Based Error Correction Codes*: Traditional error correction codes detect and correct errors using predefined algorithms and rules. In contrast, machine learning-based error correction codes aim to detect and correct errors by learning from a training dataset. This approach performs better error correction in noisy and complex communication environments [64].

Machine learning-based error correction codes can be developed using various ML algorithms such as deep learning, support vector machines, and random forests. These methods make error correction codes more flexible, scalable, and adaptable to new communication environments and challenges [65].

*Machine Learning-Based Communication Protocols*: Communication protocols regulate data communication processes and operate according to specific standards and rules.

Machine learning-based communication protocols enable more effective and compatible data exchange by analyzing network traffic and communication processes [66], [67].

Machine learning algorithms can optimize operations in communication protocols, such as flow control, error control, timing, and network routing. This allows communication protocols to respond more swiftly and effectively to changing network conditions and user demands [68], [69].

The utilization of machine learning-based methods contributes to enhancing reliability and performance in communication systems. Further research and applications in this field will develop more efficient and reliable communication systems such as energy management, monitoring, and automation systems. Moreover, using machine learning-based methods enables the development of error correction codes and protocols that can quickly adapt to new and complex communication environments [69], [70].

#### *Sample Application Areas:*

- *Wireless communication:* Machine learning-based methods can assist in detecting and correcting erroneous data packets in wireless communication systems. This enhances reliability and data transmission speed in wireless networks [71].
- *Voice and video communication over the Internet:* Protocols developed for real-time voice and video communication can benefit from machine learning algorithms to provide more effective error control and flow control. This ensures a higher-quality and uninterrupted communication experience [72].
- *Internet of Things (IoT) systems:* IoT devices typically operate with low power consumption and low bandwidth. Machine learning-based error correction codes and communication protocols can enhance data transmission reliability and energy efficiency in IoT systems [73].
- *Space and satellite communication systems:* Signals in space and satellite communication systems travel long distances and encounter various noise and interference. Machine learning-based methods can help prevent and correct erroneous data transmission in these systems, thereby improving communication reliability and efficiency [74].

As a result, using machine learning-based methods leads to significant advancements and improvements in error correction codes and communication protocols [75], [76], [77]. These methods enhance communication systems' reliability, performance, and energy efficiency, providing a better communication experience in diverse application areas. In the future, the continued use and development of machine learning-based methods will contribute to further advancements in communication technologies.

The primary motivation for this research is to explore the untapped potential of machine learning-based methods in enhancing the performance and reliability of Power Line Communication systems. The overarching goal is to contribute substantively to the scholarly field by

comprehensively reviewing existing research and practical applications in the literature. By synthesizing this knowledge, the study aims to pave the way for transformative advancements in energy management, communication, monitoring, and automation systems. Ultimately, this research aims to unlock the hidden capabilities of machine learning in PLC systems and to shape a future characterized by improved performance and unwavering reliability.

## II. MACHINE LEARNING-BASED ERROR CORRECTION CODES AND COMMUNICATION PROTOCOLS

Machine learning-based error correction codes and communication protocols are an enhanced version of error coding methods [71], [76]. These methods utilize machine learning techniques to detect and correct errors encountered during data transmission. These methods are more effective than traditional error correction coding because they perform error detection and correction based on the statistical properties of the data. Furthermore, machine learning-based error correction codes and communication protocols allow for selecting more suitable error correction codes by considering the characteristics of the transmission channel. Machine learning-based error correction codes and communication protocols are commonly employed in environments with high error rates, such as wireless communication systems. Data packets can be corrupted or lost in these systems due to atmospheric conditions or nearby obstacles. In such cases, machine learning-based error correction codes and communication protocols ensure secure and accurate data transmission.

### A. DIFFERENCES BETWEEN TRADITIONAL METHODS AND MACHINE LEARNING-BASED METHODS POWER LINE

PLC technology utilizes electrical power lines for data transmission. PLC systems often face challenges such as high levels of noise and signal distortion [78]. Therefore, error correction methods ensure accurate data transmission and reliability. Traditional error correction methods rely on pre-defined mathematical rules. Examples of conventional error correction methods used in PLC systems include duplication, parity checks, cyclic redundancy checks (CRC), and Reed-Solomon codes [79]. These methods employ specific mathematical formulas for error detection and correction. Machine learning-based error correction methods offer more effective error correction by automatically determining the characteristics and patterns of the data. In PLC systems, machine learning-based methods can detect and modify errors [51]. These methods perform error correction based on the statistical properties of the data. For instance, suitable error correction codes considering factors like channel characteristics can be selected using machine learning-based techniques. Machine learning-based error correction methods provide more effective error correction than traditional ones. However, they are more complex and have higher computational requirements. Additionally, machine learning-based methods require more data and may have longer training processes [77].

The academic literature has extensively employed PLC technology with various classification algorithms. Among the most frequently utilized methods are the following: the Naive Bayes (NB) algorithm, Linear Discriminant Analysis (LDA), Logistic Regression (LR), K-Nearest Neighbors (KNN), Support Vector Machine (SVM), Decision Tree (DT), Random Forest (RF), Adaptive Boosting (AdaBoost), Extreme Gradient Boosting (XGBoost), and various Rule-based classification algorithms. Beyond these, different other algorithms have also been integrated into practical applications. The Probability-based Logistic Regression algorithm has been deployed to estimate typical probabilities. Equation 1 herein presents the mathematical representation of the sigmoid function, also known as the logistic function (Eq2).

$$g(z) = \frac{1}{1 + \exp(-z)} \tag{2}$$

The Decision Tree (DT) is a widely recognized nonparametric supervised learning technique employed for classification and regression purposes. Within the framework of this algorithm, mathematical expressions for the ‘‘Gini’’ index, representing Gini impurity (E), and the entropy (Hx) metric for information gain are provided in Equations 3 and 4, respectively [79].

$$H(x) = - \sum_{i=1}^n p(x_i) \log_2 p(x_i) \tag{3}$$

$$E = 1 - \sum_{i=1}^c p_i^2 \tag{4}$$

Within the literature, the customary practice provides an overview of the typical architectural structure of Machine Learning (ML) applications utilizing PLCs.

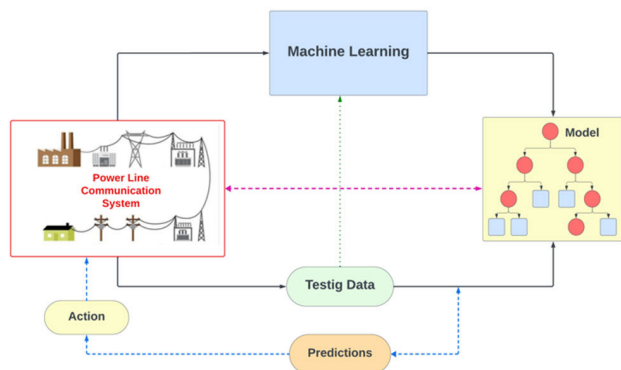

FIGURE 5. The architecture of machine learning-based PLC [79].

This structure typically delineates three fundamental components: the database, the testing data, and the model prediction pertaining to the data received by the PLC (Figure 5). The classification tree algorithm model is given in Figure 6.

**B. MACHINE LEARNING-BASED ERROR CORRECTION CODES**

PLC systems encounter challenges such as high noise and signal distortion levels, requiring error correction

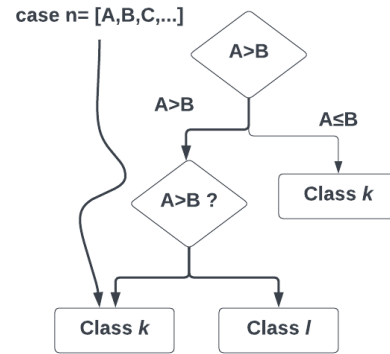

FIGURE 6. Classification tree algorithm model [79].

methods to ensure accurate data transmission and reliability. Traditional methods are based on pre-defined mathematical rules and employ specific mathematical formulas for error detection and correction. However, the effectiveness of traditional methods can be limited. Machine learning-based methods offer more effective error correction by automatically determining the characteristics and patterns of the data [77], [78]. These methods perform error correction based on the statistical properties of the data. For instance, suitable error correction codes can be selected considering factors such as channel characteristics. Machine learning-based error correction methods are more effective than traditional ones [80]. These methods automatically detect and correct errors, ensuring accurate and reliable data transmission [81]. However, these methods are more complex and have higher computational requirements.

Moreover, they require a greater data volume and may entail lengthier training processes. Machine learning-based error correction codes for PLCs can be harnessed to effectively detect and rectify errors within PLC systems [51], [80]. These methodologies can potentially enhance system performance and ameliorate data transmission quality. Machine learning-based error correction codes for PLCs hold substantial value in critical applications such as data transmission within intricate systems like smart grids and power distribution networks [61], [62].

In this study, a feedforward neural network with 10 hidden neurons was constructed using a synthetic dataset. The model was trained on this synthetic dataset to make predictions. By comparing these predictions with the actual data, we visualize the performance of the trained neural network. The legend in Figure 7 clarifies the distinction between the actual data points and the model’s predictions, allowing for a comprehensive evaluation of the neural network architecture.

The performance analysis for PLC based on synthetic data is presented in Figure 8. The results are categorized into training, validation, testing, and the best performance outcomes. The optimal validation performance achieved a value of 0.55432 at epoch 4.



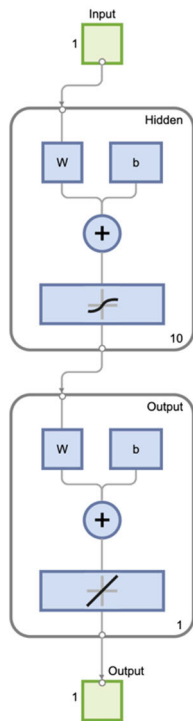

FIGURE 7. Feed-forward neural network architecture.

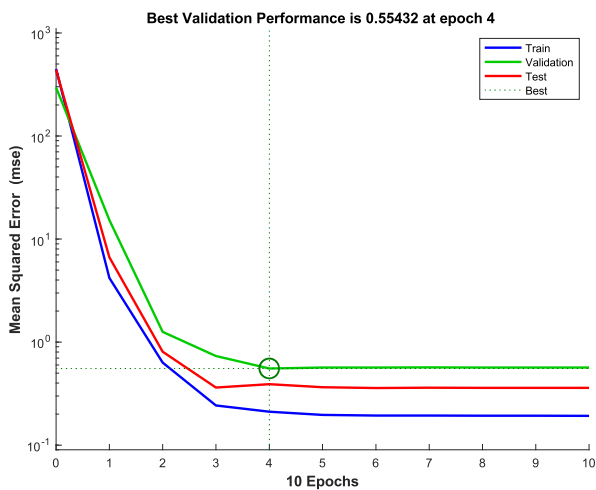

FIGURE 8. Performance analysis of the PLC model.

The Error-Target outputs plot for the PLC model is depicted in Figure 9. The graph displays the training, validation, test, and zero error variations over the training iterations.

In Figure 10, the training and regression analysis graph for the PLC model is given. Here, the values are 0.99687 for Training, 0.99115 for Validation, 0.99571 for Test, and 0.99575 for all.

Data division is randomly selected in the training algorithm, Training Levenberg-Marquardt, performance mean squared error and calculation max. The training process table is given in Table 1.

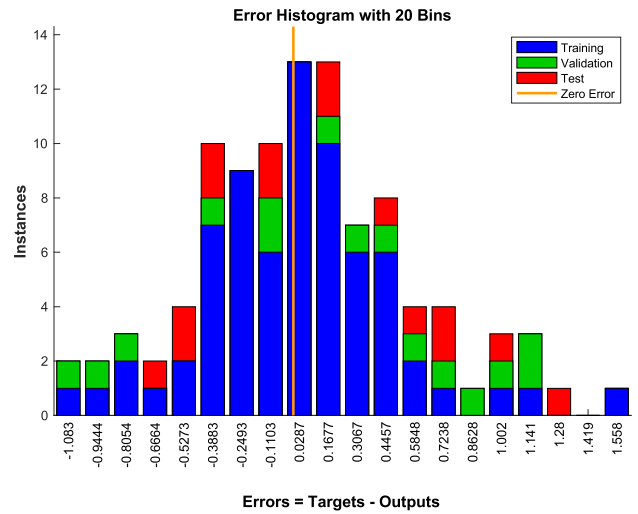

FIGURE 9. Error-Histogram graph for the PLC model.

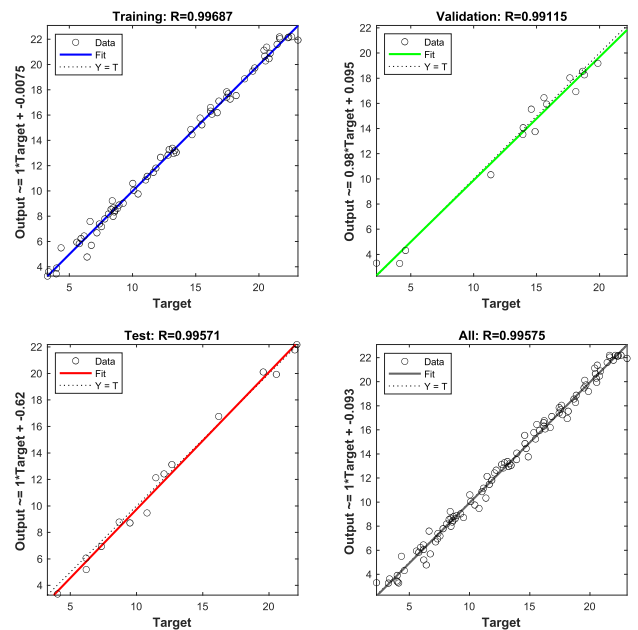

FIGURE 10. Training and Regression analysis for the PLC model.

TABLE 1. Training process.

Unit	Initial Value	Stopped Value	Target Value
Epoch	0	10	1000
Elapsed Time	-	00:00:00	-
Performance	447	0.193	0
Gradient	735		1e-07
Mu	0.001	0.001	1e+10
Validation Check	0	6	6

1) DEEP LEARNING-BASED ERROR CORRECTION CODES  
 Deep learning is a machine learning technique encompassing multi-layered learning processes over artificial neural networks to extract meaningful features from data [82].

This method has achieved significant success in various domains, with error correction codes among them. Deep learning-based error correction codes are employed in communication systems that contend with high levels of noise and signal degradation [83], [84]. These techniques enhance error correction efficiency by automatically discerning data characteristics and patterns.

Deep learning-based error correction codes primarily operate on specialized neural networks for encoding and decoding [84]. These neural networks can be of different types, such as convolutional neural networks or recurrent neural networks. These networks extract specific features from the data and use these features in error detection and correction. Deep learning-based error correction codes offer more effective error correction than traditional methods [85]. However, these methods are more complex and have higher computational requirements. Additionally, they require more data and may have longer training processes. In conclusion, deep learning-based error correction codes may have higher accuracy rates than traditional methods. However, different neural network models and appropriate hyperparameter tuning may be required depending on the application domain.

## 2) SUPPORT VECTOR MACHINES-BASED ERROR CORRECTION CODES

Support Vector Machines (SVM) are machine learning's widely used classification and regression methods [86]. SVM can achieve high accuracy rates in linear and non-linear problems, making SVM-based error correction codes applicable to error correction processes in PLC systems. SVM-based error correction codes rely on the assumption of linear separability in the data [87]. SVM positions data points in a multi-dimensional space and creates an optimal separating hyperplane for classification [86]. SVM ensures maximum margin separation while creating the hyperplane, allowing for determining boundaries in the widest possible manner [87], [88]. SVM-based error correction codes yield good results even in noisy data. SVM can automatically determine the features of the data, enabling the selection of the most suitable codes for error correction. SVM-based error correction codes can reduce the dimensionality of the data, thereby shortening the processing time [89], [90]. SVM-based error correction codes also have disadvantages similar to machine learning-based methods. SVM is a computationally intensive method that may need improvement for large datasets [91]. Moreover, SVM's premise of linear separability might only sometimes apply to specific problems. Error correction codes based on SVM can serve as a substitute for conventional methods used in PLC systems [92]. SVM can autonomously identify data features and select the most appropriate error correction codes [93]. Nonetheless, SVM can be computationally demanding, and the linear separability presumption might only sometimes be valid for specific issues.

In Figure 11, the process of estimating with the SVM is demonstrated. The code generates a synthetic dataset and

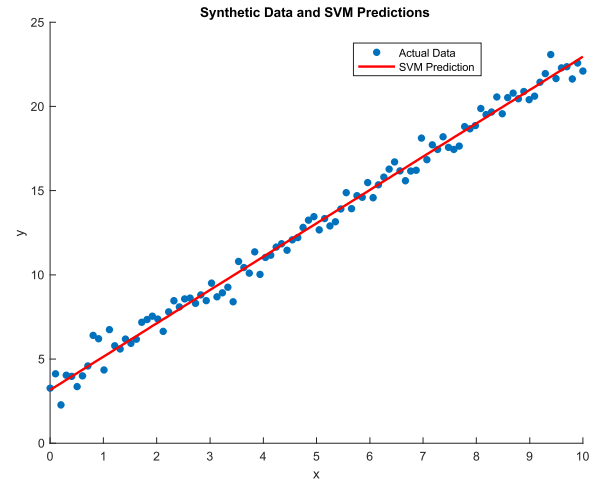

FIGURE 11. Synthetic data and SVM prediction.

constructs and trains the Support Vector Machine (SVM) model using the *fitrsvm* function. Subsequently, it plots the predictions made by the trained SVM model alongside the actual data points. This visualization clearly represents both the synthetic data and the model's estimations.

## 3) RANDOM FOREST-BASED ERROR CORRECTION CODES

Random Forests are commonly used algorithms in machine learning [94]. This algorithm combines multiple decision trees to create a classification or regression model. Random Forests perform well on high-dimensional and complex data. Random Forests can also be used for error correction codes [95]. In this case, the Random Forest algorithm analyzes the transmitted data to detect and correct errors [96]. This method yields better results than traditional error correction methods because the Random Forest algorithm can better determine relationships and patterns within the data. When used for error correction codes, the Random Forest algorithm first creates a model using sample data. This model is then used to detect errors in the data. Once errors are detected, the Random Forest algorithm corrects them using a specific error correction code. Random Forest-based error correction codes perform well on high-dimensional and noisy data. They also require less computational power than traditional methods and have a faster training process. However, Random Forest-based error correction codes require sufficient sample data to build the model. Otherwise, the model may need to be revised or provide misleading results.

Figure 12 illustrates the graph representing the synthetic data and the predictions made by the random forest algorithm. Upon examination of the graph, it becomes evident that the random forest predictions algorithm successfully accurately approximates the data.

## C. MACHINE LEARNING-BASED COMMUNICATION PROTOCOLS

PLC is a technology used for data transmission over electrical power lines. PLC systems face challenges such as high

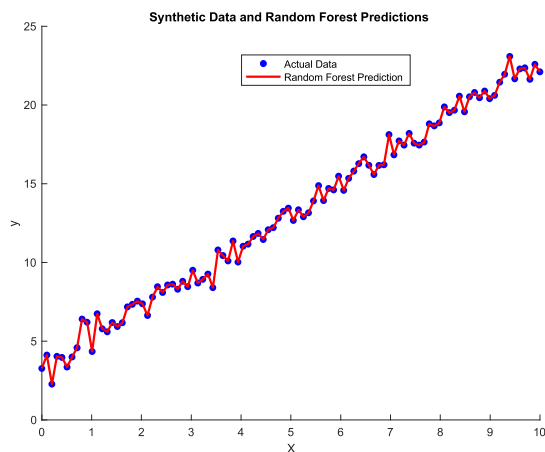

FIGURE 12. Synthetic data and random forest predictions.

levels of noise and signal distortion, necessitating specialized communication protocols to ensure accurate data transmission and reliability. Traditional communication protocols are rule-based and may need help to adapt to changing communication conditions [78].

Machine learning-based communication protocols learn communication conditions automatically to determine the most suitable communication strategies [51], [80]. These protocols analyze data using various machine learning algorithms and select the optimal protocol based on the communication conditions. This improves communication quality and enables communication protocols to adapt to changing conditions [81].

Machine learning-based communication protocols also ensure data security. Data encryption is crucial for data privacy and security. Machine learning-based protocols automatically detect security vulnerabilities and implement necessary measures to enhance security [97], [98], [99].

However, machine learning-based communication protocols typically begin with signal processing and feature extraction steps to analyze data characteristics and channel conditions. These steps involve extracting data features, reducing noise and signal distortion, analyzing frequency spectra, and feeding this data into machine learning algorithms [100]. Machine learning algorithms, particularly support vector machines, random forests, deep neural networks, and various clustering algorithms, can assist in accurate data classification and error correction processes in the transmission channel [77]. Machine learning-based communication protocols can provide higher reliability and efficiency for data transmission in PLC systems. However, implementing this technology may present practical challenges due to the need for high computational power and data resources, especially for data collection and processing steps.

#### 1) DEEP LEARNING-BASED COMMUNICATION PROTOCOLS

Deep learning-based communication protocols perform error correction based on the statistical characteristics of data,

distinguishing them from traditional protocols used in PLC systems [101]. These protocols can analyze data and select error correction codes suitable for channel characteristics. Additionally, deep learning algorithms can optimize data flow and perform data compression operations in power systems [101], [102].

Deep learning-based communication protocols in PLC systems can perform higher error correction than traditional protocols [102]. Moreover, due to their flexible and adaptable nature, they can better adapt to changing conditions in PLC systems. However, deep learning-based communication protocols are more complex and require higher computational requirements than traditional protocols [103]. Furthermore, these protocols require more data for training and have longer training processes. Therefore, selecting the most suitable communication protocol for PLC systems is done by considering the system's characteristics and requirements [104].

#### 2) SUPPORT VECTOR MACHINES-BASED COMMUNICATION PROTOCOLS

Support Vector Machines (SVM) based communication protocols are among the most effective methods for error correction and signal enhancement in PLC systems. SVM is a machine learning method used for data classification or regression analysis. SVM is highly successful in classifying data linearly or non-linearly, and it is also robust against noise [77], [78].

In PLC systems, SVM-based communication protocols are used for data categorization and selection of error correction codes [89], [90]. Here, SVM analyzes the statistical characteristics of data and determines the appropriate error correction codes. Additionally, SVM-based protocols improve signal quality and reduce noise [105].

Compared to other machine learning-based communication protocols, SVM-based communication protocols require less computational power and less data [106]. Thus, they are preferred in scenarios where computational resources are limited and a smaller amount of data is available.

#### 3) RANDOM FORESTS-BASED COMMUNICATION PROTOCOLS

Random Forests-based communication protocols are known for their significant efficacy in guaranteeing precise data transmission and proficient error detection and correction within PLC systems [107]. By leveraging the statistical attributes of the data, Random Forests excel at error correction and establish diverse decision trees for error detection purposes. Moreover, they can autonomously identify the distinctive features of the data [95], [96].

This approach performs better than conventional methods frequently used in PLC systems regarding error correction. However, it's crucial to remember that this protocol requires more processing power because of its computing needs and necessitates a more extensive set of data, which lengthens the training process compared to other protocols.

### III. EVALUATION OF MACHINE LEARNING-BASED METHODS IN PLC SYSTEMS

Machine learning-based error correction codes and communication protocols offer superior efficacy and efficiency in PLC systems compared to conventional approaches [108], [109]. Nevertheless, several factors must be considered when employing and evaluating these techniques. Primarily, the accurate implementation of machine learning algorithms necessitates ample and representative datasets [78]. These datasets should encompass various noise levels, signal distortions, and other variables encountered in PLC systems. Additionally, machine learning-based methods rely on the system's processing power and memory capacity. The training and implementation of these methods may require substantial computational resources. Consequently, carefully evaluating processor capacity and system requirements is imperative when selecting the appropriate method.

Machine learning-based error correction codes and communication protocols in PLC systems tend to be more intricate and place greater demands on processor power than traditional approaches [110], [111]. However, owing to their ability to deliver enhanced outcomes and higher data accuracy, they are expected to play a pivotal role in numerous applications within PLC systems.

#### A. SIMULATION EXPERIMENTS

A simulation experiment uses a dataset obtained from a PLC system, encompassing data collected under various speeds, noise levels, and signal distortion conditions [112], [113], [114]. This dataset can be a training set for diverse machine learning-based error correction methods. Once the training set is established, the performance of machine learning-based error correction methods is assessed using test data. These test data incorporate measurements from different speeds, noise levels, and signal distortion conditions. They evaluate error correction methods' accuracy, precision, and performance in specific scenarios.

Simulation experiments can also be carried out to evaluate different machine learning-based communication protocols [115], [116]. In these experiments, datasets and test data can be gathered explicitly for a given communication protocol, enabling the assessment of its performance. Essential features such as transmission rate, latency, and protocol reliability can be measured during these experiments. The outcomes of simulation experiments provide insights into the efficacy of machine learning-based error correction methods and communication protocols in real-world applications [117], [118]. Moreover, these experiments facilitate the comprehension of parameter effects and the optimization of parameters to achieve optimal results.

#### 1) SIMULATION EXPERIMENTS FOR ERROR CORRECTION CODES

Simulation experiments are conducted to assess the effectiveness of machine learning (ML) based error correction codes

in PLC systems. These experiments encompass the following stages:

*Data collection:* Data is acquired using systems such as Advanced Metering Infrastructure (AMI) or Electric Power Communication Networks (EPIC) [119].

*Data processing:* The collected data is processed into a format suitable for error correction algorithms. This involves preprocessing steps to eliminate noise, extract relevant features, and perform feature selection [120].

*Algorithm training:* ML-based error correction algorithms are trained using the collected data. The trained model analyzes the statistical properties of the data to identify and rectify errors [121].

*Performance evaluation:* The trained model is tested using real-time data to evaluate its performance. Performance metrics, including accuracy, precision, specificity, false positive rate, and false negative rate, are employed to assess the model's effectiveness [122].

The conducted research reveals that the results of simulation experiments demonstrate that ML-based error correction algorithms outperform traditional approaches. Additionally, it is possible to determine the most suitable error correction algorithm by comparing the performance of various algorithms.

#### 2) SIMULATION EXPERIMENTS FOR COMMUNICATION PROTOCOLS

Simulation experiments are conducted to evaluate the performance of communication protocols in PLC systems. The following simulation experiments are carried out:

*Channel Characterization:* Communication channels in PLC systems often operate in noisy environments with potential signal distortions. Therefore, channel characterization is crucial. Through simulation experiments, the characteristics of the communication channel, such as noise level and signal loss, are determined to assess the performance of communication protocols [123].

*Bit Error Rate (BER) Analysis:* Errors may occur during data transmission in PLC systems, and the rate of these errors is expressed as the Bit Error Rate (BER). Simulation experiments enable BER analysis for different communication protocols. These analyses evaluate the protocols' error tolerance and data accuracy [124].

*Data Flow Rate Analysis:* The data flow rate is a critical criterion in PLC systems. Simulation experiments are conducted to analyze the data flow rate for different communication protocols, measuring their data transmission speed and performance [125].

*Reliability Analysis:* Simulation experiments employing various communication protocols are conducted to test data reliability in PLC systems. These analyses assess the protocols' data accuracy, reliability, and error tolerance [126].

*Energy Efficiency Analysis:* Energy efficiency is a significant criterion for PLC systems operating through the power grid. Simulation experiments are used to analyze the energy

efficiency of different communication protocols, determining their energy consumption and performance [127], [128].

Based on the results of simulation experiments, a comparison can be made among different communication protocols, leading to the selection of the most suitable protocol. Additionally, simulation experiments are utilized to enhance the performance of protocols.

### B. REAL-WORLD EXPERIMENTS

Real-world experiments evaluate the efficacy of machine learning ML-based communication protocols and error correction codes in PLC systems [129]. These experiments are typically carried out within the context of energy distribution systems [130], [131].

Real-world experiments are commonly implemented as field tests or pilot applications [130], [131]. Multiple PLC systems are employed to assess the performance of ML-based communication protocols and error correction codes under real-world operational conditions [76], [132].

During these experiments, PLC systems are deployed in actual energy distribution networks, and the real-time data transmission is meticulously monitored. The experiments entail observing diverse factors, including noise levels, signal distortions, and other network-related parameters. The collected data is subsequently analyzed to evaluate the performance of ML-based communication protocols and error correction codes [133].

Despite the higher costs and more prolonged duration associated with real-world experiments than simulation experiments, the data obtained under real-world conditions tend to offer greater representativeness than simulation results. To accurately evaluate the effectiveness of ML-based communication protocols and error correction codes, real-world experiments are a crucial tool.

#### 1) REAL-WORLD EXPERIMENTS FOR ERROR CORRECTION CODES

Real-world experiments are typically conducted in industrial settings to evaluate the performance of PLC systems under realistic conditions [119]. These experiments involve an initial assessment of the system's current state and identifying performance improvement areas. Subsequently, the system's performance is assessed by employing different error correction codes [120], [121].

Real-world experiments are often conducted as field tests to measure the system's performance using various error correction codes and assess how PLC systems operate in real-world scenarios [122].

Although real-world experiments are more intricate and costly than simulation experiments, they allow one to consider factors that cannot be observed in simulations. Real-world experiments are also instrumental in evaluating the real-world performance of error correction codes.

### C. PERFORMANCE EVALUATION AND COMPARISON

In the realm of ML-based error correction codes and communication protocols, the research underscores the paramount

significance of performance evaluation and comparison as pivotal criteria for ascertaining these technologies' efficacy and practical utility [134].

Performance evaluation entails the systematic conduction of tests aimed at gauging the proficiency of an algorithm against predefined performance metrics [135]. These metrics encompass a wide array of parameters, including but not limited to accuracy, precision, specificity, F1 score, mean absolute error, and mean squared error, among others. It is imperative to acknowledge that the performance of an algorithm constitutes a variable parameter influenced by a multitude of factors, such as the nature of the datasets employed for testing, the chosen performance metrics, and other pertinent variables.

Conversely, comparison is a pivotal criterion employed to juxtapose and assess the performance of diverse algorithms. These comparative analyses entail the utilization of identical performance metrics in tandem with examining algorithms using the same datasets. This meticulous approach facilitates the discernment of superior or inferior algorithmic performance under specific contextual circumstances. Ultimately, performance evaluation and comparison, as applied to ML-based error correction codes and communication protocols, provide critical insights into how these technologies will likely perform in authentic, real-world applications.

The significance of performance evaluation and comparison is undeniable in the ML-based Error Correction Codes and Communication Protocols for Power Line Communication (PLC). However, several complex challenges and multifaceted considerations come into play, shaping the landscape of this research field.

*Diverse Data Sets:* The diversity of data sets employed for testing exerts a profound influence on the outcomes of performance evaluations. Researchers face the crucial task of meticulously curating representative data sets encompassing many real-world scenarios. This diversity is essential to ensure the robustness and generalizability of ML algorithms across various operational contexts.

*Performance Metrics Selection:* The selection of appropriate performance metrics demands thoughtful deliberation. Different metrics may hold varying degrees of relevance for specific applications within the PLC system. Researchers must carefully align their choice of metrics with the precise objectives and requirements of the PLC system under scrutiny.

*Real-World Variability:* Real-world PLC environments are characterized by their dynamic and unpredictable nature. Variations in noise levels, interference, network congestion, and other environmental factors pose significant challenges. Thorough evaluations of algorithm performance under such authentic conditions are indispensable to gauge practical applicability accurately.

*Scalability:* In the context of large-scale PLC systems, the scalability of ML-based error correction codes and communication protocols assumes paramount importance. Researchers must explore how these technologies fare as the scale of the

network expands, ensuring that their functionality remains effective and efficient.

*Computational Resources:* The computational resource requirements of ML-based algorithms warrant careful consideration, as they can significantly impact the feasibility of deployment. Developing algorithms that operate optimally within specified resource constraints is a coveted objective.

*Generalization:* Ensuring the robust generalization of algorithms to diverse PLC infrastructures and deployment scenarios is of utmost importance. Overfitting to specific data sets should be vigilantly avoided to guarantee consistent and reliable performance across diverse operational contexts.

*Security:* Security concerns come to the forefront with the increasing integration of ML-based algorithms into PLC systems. Comprehensive evaluations should encompass facets of algorithmic security, including vulnerability assessments pertaining to potential adversarial attacks.

The comprehensive assessment of ML-based Error Correction Codes and Communication Protocols for Power Line Communication demands a nuanced, multifaceted approach to performance evaluation and comparison. Researchers must navigate the intricate landscape defined by diverse data sets, metric selection, real-world variability, scalability considerations, computational efficiency, generalization requirements, and security concerns. Addressing these formidable challenges is instrumental in advancing and refining ML-based solutions within the realm of PLC systems.

#### IV. RELATED WORK ON ML BASED ERROR CORRECTION CODES AND COMMUNICATION PROTOCOLS

Machine learning-based error correction codes and communication protocols have become one of the most popular research topics in recent years [132]. There are numerous studies available in the literature on this subject. Deep Learning-Based Error Correction for Power-Line Communications”: This paper discusses the use of deep learning methods for error correction coding in PLC systems. The study combines coding methods used in PLC systems and deep learning methods to achieve higher accuracy rates [136].

Several important applications [137], [138] have been developed for accelerating the reinforcement learning-based channel estimation process in OFDM systems and for analysis, such as machine learning methods, deep learning, robust meta-learning, performance analysis, low complexity, and estimation methods [139], [140].

In studies conducted on Machine Learning-Aided Signal Processing for Power Communications, machine-learning methods have been used to achieve higher performance in signal processing operations such as channel estimation, signal detection, and code decoding [7], [141].

Powerline communication has transcended its conventional applications in the smart grid (SG) and found extensive use in various domains [142], [142]. Originally employed for two-way SG communication, advanced metering infrastructure (AMI) applications, demand response, and power system control, PLC now serves diverse purposes. These include

broadband Internet applications, consumer home automation, enabling grid-wide artificial intelligence (AI) applications, and utilizing PLC modems as sensors for monitoring grid health, among others. ML-based studies conducted in this field have investigated the impact on communication systems in narrow and wide-band applications [143], [144]. Moreover, the effectiveness of PLC network devices, commonly employed in these studies, has been enhanced through the deterministic data optimization approach [145]. Additionally, the suitability of PLC impedance estimation has been discussed [146], [147]. The performance of estimators was thoroughly analyzed and evaluated through numerical assessments [148].

In the challenging power line environment characterized by significant impulsive noise (IN), it is possible to achieve more precise channel estimation compared to conventional strategies. Instead of focusing on suppressing the IN-affected samples in the received signal, a more effective approach involves estimating the IN and integrating it into the channel estimation process [18]. This can be accomplished by utilizing signal processing schemes proposed in [19], [20], and [21] to estimate the sparse IN components present in the received signal. A likelihood function can be formulated to leverage the estimated IN and observations of the received signal. As a result, the channel coefficients can be determined by estimating parameter values that maximize the likelihood function [148].

#### A. A MACHINE LEARNING-BASED CHANNEL ESTIMATION METHOD FOR VEHICULAR COMMUNICATION SYSTEMS

This study deals with the use of machine learning methods in channel estimation in-vehicle communication systems. The study proposed a deep learning-based channel estimation method, and higher accuracy rates were obtained according to the simulation results compared to other methods. In addition, studies and applications are carried out for machine learning-based error correction codes and communication protocols in wireless networks, image and video compression, radar, and similar fields. Machine learning-based error correction codes and communication protocols are widely used in both academic and industrial applications [149]. Some examples are:

*Intelligent energy management:* Smart grids use machine learning-based communication protocols to collect, analyze, and manage data in electricity transmission and distribution systems [150].

*Automotive industry:* In the automotive industry, machine learning-based error correction codes are used to improve the accuracy of sensor data in vehicles [151].

*Telecommunications:* In the telecommunications industry, machine learning-based error correction codes are used to correct errors in both communication and PLC lines [152].

*Finance:* In the financial industry, machine learning-based communication protocols can help banks interact smarter with customers and increase the accuracy of financial data [153].

*Medicine:* In the medical industry, machine learning-based error correction codes are used to increase the accuracy and reliability of data in hospital systems. This area is one of the most important application areas [154].

*Agriculture:* In the agricultural industry, machine learning-based communication protocols are used to increase the accuracy of soil data and agriculture sensor data [155].

In the field of Machine Learning-based PLC systems, the utilization of the end-to-end learning process is prevalent. This process facilitates the autoencoder in discovering a robust representation of the input signal, thereby enabling the identification of optimal encoding and decoding strategies for stochastic channels. Notably, the autoencoder can achieve a solution that surpasses the performance of existing modulation and encoding methods [156], [157]. Moreover, the autoencoder approach operates without making any assumptions about the channel and, in theory, can comprehend the dynamics of the PLC channel without relying on its current manifestation as a linear periodic time-variable system [66], [156]. To implement this concept, an autoencoder has been developed using TensorFlow libraries [66], [158] specifically for integration into PLC systems. A schematic depiction of this implementation can be found in Figure 13.

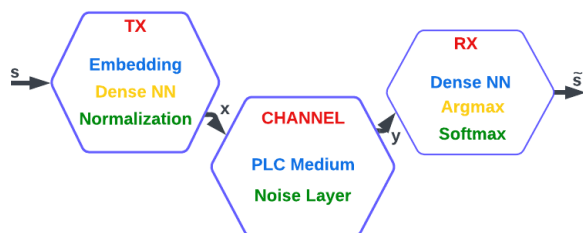

FIGURE 13. Semantic description of a PLC system via an autoencoder model [66].

## V. FUTURE DIRECTIONS

Machine learning-based error correction codes and communication protocols are widely used in electric power transmission systems, which are of paramount importance in all stages of electrical power transmission, distribution, and control. These technologies enhance energy efficiency by providing reliable and high-performance communication, facilitating system fault detection, and enabling error correction capabilities.

Current studies demonstrate that machine learning-based error correction codes offer high accuracy, sensitivity, and performance levels for PLC systems. Similarly, machine learning-based communication protocols represent a significant advancement in terms of efficiency, speed, and reliability within PLC systems.

However, challenges persist in this field. A better understanding of factors that may impact the performance of machine learning-based error correction codes and communication protocols in real-world applications is needed.

Concerns about installation and management costs and security and data privacy must also be addressed.

Research in this area is expected to focus on integrating advanced technologies, such as artificial intelligence and deep learning techniques. Furthermore, developing new methods by exploring additional application scenarios will likely render these technologies more suitable for industrial use.

It is evident that machine learning-driven error correction codes and communication protocols hold substantial promise in substantially augmenting the performance of PLC systems. Furthermore, their adoption is anticipated to experience further proliferation in the foreseeable future.

### A. POTENTIAL ADVANTAGES AND LIMITATIONS

Machine learning-based error correction codes and communication protocols are a major advance for PLC systems and other engineering applications. Potential advantages include [66], [70]:

*Higher efficiency:* Machine learning algorithms can quickly process data to generate error-correcting codes and communication protocols. This means higher efficiency and less downtime [159], [160].

*Lower cost:* Traditional error correction methods and communication protocols rely on manpower and are implemented manually. Machine learning-based approaches can reduce these costs and provide a more economical solution.

*Higher accuracy:* Machine learning algorithms can generate more accurate error correction codes and communication protocols. This means fewer bugs and better system performance [159], [160]. However, these approaches also have some limitations:

*Data constraints:* Machine learning algorithms need sufficient and representative data to achieve high accuracy. Sometimes, there may not be enough data, or the quality may be poor.

*Model complexity:* The complexity of machine learning models can slow down the learning process or reduce efficiency [70]. Also, very complex models may become impractical due to hardware constraints in their application area [159], [160].

*Reliability issues:* Machine learning models can be vulnerable to false data or attacks. Therefore, additional measures may be required to increase reliability.

*Situations requiring human intervention:* In some cases, the results of machine learning models may need human validation or intervention [70], [161].

Machine learning-based error correction codes and communication protocols may become more common in industrial applications. Advances in data collection technologies can enable the collection of more and better quality data. In addition, stronger hardware and software infrastructure can enable more complex machine learning models to be used. Although machine learning-based error correction codes and communication protocols have significant potential to improve the performance of communication systems, they

also come with some limitations. These limitations may include the need for high computational power, insufficient data sets, misleading data affecting the accuracy of algorithms, overfitting problems, model explainability, intelligibility, scalability, and security issues.

However, advanced algorithms and technologies may solve many of these limitations. For example, algorithms can run faster by using hardware with higher computing power. In addition, dataset creation and editing processes can be made more efficient and effective [14], [15]. More advanced algorithms and techniques can be developed to detect and process misleading data. Overfitting problems can be reduced by developing more complex models and improving model selection techniques [31], [66]. Model explainability and intelligibility problems can be addressed by making algorithms more transparent or by using interpretable models. Scalability issues can be reduced by developing algorithms that work with larger data sets and using more efficient hardware. Security issues can be resolved with more advanced encryption and authentication techniques [66], [70].

Future directions in this area could be the development of more complex and intelligent systems, using more data sets, using more advanced scalability and security techniques, and exploring more industrial applications. In addition, researchers and engineers working in this field should continue to work on the development of more effective, efficient, and optimized algorithms for machine learning-based error correction codes and communication protocols.

## B. SUGGESTIONS FOR FUTURE WORK

Several recommendations for prospective research directions within the realm of machine learning-based error correction codes and communication protocols are as follows:

*Data collection:* Extensive data collection and sampling efforts are imperative to assemble larger, more diversified datasets. This augmentation of data sources can substantially enhance the accuracy and efficiency of machine learning algorithms.

*Modeling:* Developing more intricate and advanced machine learning models is crucial for refining error correction and communication protocols. These models can be meticulously tailored and optimized to yield superior accuracy and efficiency in their outcomes.

*Enhanced Classification:* Employing superior feature selection techniques and advanced data preprocessing methods is essential for elevating the classification accuracy of machine learning algorithms.

*Implementation:* Efforts should be directed towards rendering machine learning-based error correction codes and communication protocols more universally applicable. This expansion will broaden their utility across a spectrum of industrial and commercial applications.

*Comparative:* Comparative evaluations should be undertaken to discern the performance disparities among diverse machine learning-based error correction codes and communication protocols. This comparative analysis can help

identify the technologies that offer optimal performance characteristics.

*Security:* Further research is required to fortify the security attributes of machine learning-based error correction codes and communication protocols, focusing on mitigating vulnerabilities.

*Optimal Design:* In-depth research endeavors are necessary to ascertain the optimal design parameters of machine learning-based error correction codes and communication protocols, ensuring their maximal effectiveness.

*Exploration of Novel Approaches:* The exploration of innovative approaches and techniques within the domain of machine learning-based error correction codes and communication protocols should be vigorously pursued. This exploration presents opportunities to surmount the limitations inherent in existing methodologies and to deliver superior performance outcomes

## VI. DISCUSSION

The originality of this article can be summarized under two main headings. Firstly, it represents an innovative application as a PLC-based machine learning error correction code algorithm, proposing a novel algorithm. Secondly, it provides a comprehensive literature overview and aligns with previous research endeavors.

Unsal and Yalcinoz [164] developed a novel model based on power line communication (PLC) in their study. Additionally, Huang et al. [165] employed the Q-learning algorithm to search for the optimal attack sequence against lines in a dependent power-communication network, leveraging a model to simulate stepwise faults that occur in the communication network. The system proposed by Hashim and Al-Mashhadani [166], engages with the IoT system and directly visualizes real-time data. Efforts have been made here to facilitate the distribution of the measurement network over the cloud environment. Practical results indicate that packet losses in the received data are approximately 0, 1, or 2 characters, and the time difference between the transmitter and receiver is approximately 5000 milliseconds. In the paper authored by Omaer et al. [167], a machine learning-based autonomous fault detection and fault classification system is proposed, where extreme machine learning is employed for fault detection and classification. A study conducted by Ramesh et al. [168] explored the outage probability performance of hybrid protocols in power line communication.

In the study conducted by Oliver et al., a deep learning approach is proposed for detecting trees encroaching on power and communication lines using street-level images. This approach further involves performing rapid quantitative and qualitative analyses based on the Grad-CAM++ method [169]. In the research conducted by Topaloglu [170], a novel approach based on Convolutional Neural Networks (CNN) has been developed to classify a specific power signal according to its relevant power quality condition. Utilizing the Attention Model approach, accuracy and error values for the Power Quality (PQ) in the electrical power



system were obtained, dependent on the absence or scarcity of direct power disturbances.

Other studies in the literature, as listed in Table 2, predominantly fall into either classical classification methods or fault detection methods or are based on Artificial Neural Networks (ANN) for fault identification and error code purposes. Across these studies, Machine Learning (ML) is commonly employed for data analysis in PLC systems. In this regard, the proposed method within our research framework effectively addresses a significant gap within the domain of Machine Learning-Based Error Correction Codes and Communication Protocols for Power Line Communication.

Some suggestions for future work in the field of machine learning-based error correction codes and communication protocols can be:

*Data collection:* More data collection and sampling should be done to create larger and more diverse datasets. This will help machine learning algorithms become more accurate and efficient.

*Modeling:* More sophisticated machine learning models should be developed for better error correction and communication protocols. These models can be optimized to produce more accurate and efficient results.

*Classification:* Better feature selection and data preprocessing techniques should be used to increase the classification accuracy of machine learning algorithms.

*Implementation:* Machine learning-based error correction codes and communication protocols should be made more widely applicable. This will provide a wider range of use in industrial and commercial applications.

*Comparison:* Comparisons should be made between different machine learning-based error correction codes and communication protocols. This will help identify technologies that provide the best performance.

*Security:* Machine learning-based error-correcting codes and communication protocols need further research to further protect against vulnerabilities.

*Optimal design:* Machine learning-based error-correcting codes and communication protocols require further research to determine their optimal design.

*New approaches:* New approaches and techniques should be explored in the field of machine learning-based error correction codes and communication protocols. This will present opportunities to overcome the limitations of existing methods and provide better performance.

This study investigated communication protocols and error correction codes in Machine Learning PLC [66]. ML techniques can be used in areas such as studies in this field, energy efficiency optimization, error detection and prediction, and power quality analysis [43], [70]. ML algorithms can optimize the data transmission of the PLC system, increase energy efficiency by monitoring and analyzing energy consumption, predict line faults, and improve power quality.

ML-based PLC studies are classified in Table 2 below with their references.

**TABLE 2.** Existing survey and literature review articles with the main focus highlighted and compared to this paper.

Group	References
Power Line Communications	[1], [2], [3], [5], [18], [26], [27], [28], [54], [61], [64], [75], [114], [133], [141]
Smart Grid Studies	[4], [10], [15], [40], [61], [65], [114], [145], [146], [162], [163], [164]
PLC with ML	[66], [67], [78], [83], [84], [107], [109], [115], [118], [140], [142], [143]
Error Correction Codes	[22], [48], [49], [79], [110], [126], [136], [137], [138], [139], [44], [165]
Decision Tree	[31], [34], [36], [79], [95], [96]
SVM	[79], [86], [87], [88], [89], [90], [91]
Deep Learning	[82], [83], [84], [169]

From a practical application perspective, when discussing potential deployment scenarios of Machine Learning for Error Correction Codes and Communication Protocols in Power Line Communication, several approaches can be outlined as follows:

*Data-Driven Error Correction Codes:* Machine learning can be leveraged to enhance the error correction codes of PLC systems. More effective codes can be devised using extensive historical data to address communication errors and corrections.

*Adaptive Communication Protocols:* Machine learning can be employed to create adaptive communication protocols that continuously monitor and assess network conditions. These protocols can dynamically adapt to changing noise levels, traffic patterns, and other factors within the network.

*Cybersecurity and Anomaly Detection:* Machine learning can be crucial in bolstering the cybersecurity of power line communication networks. Techniques such as anomaly detection and malicious software identification can be applied to enhance network security.

*Spectrum Efficient Utilization:* Machine learning can contribute to efficiently utilizing the spectrum. It can assist in selecting the optimal frequencies and channels for data transmission in the RF spectrum.

*Energy Efficiency:* Machine learning can contribute to the development of energy-efficient communication protocols, reducing the energy consumption of PLC systems.

These scenarios represent practical approaches that can be employed to evaluate the impact of machine learning on Error Correction Codes and Communication Protocols in Power Line Communication. However, it is essential to note that each scenario has unique challenges and application domains, and their feasibility should be carefully examined.

## VII. CONCLUSION

This paper examines the utilization and effectiveness of machine learning-based methods for error correction codes and communication protocols in PLC systems. The focus is on popular machine learning techniques such as deep learning, support vector machines, and random forests. Results obtained from simulations and real-world experiments demonstrate that machine learning-based methods can significantly improve the performance of PLC systems, especially in challenging communication environments and noisy channels.

Furthermore, it has emphasized the pivotal role played by machine learning-based error correction codes and communication protocols in enhancing the reliability and performance of PLC systems. By examining the existing academic research and industrial applications, it has been observed that research and applications in this field are rapidly advancing. Notably, machine learning techniques have been found to play a critical role in augmenting both the reliability and effectiveness of PLC systems.

The discussion and future directions section assesses the potential advantages and challenges of machine learning-based error correction codes and communication protocols. Recommendations for future research and potential application areas in this field are also provided.

Additionally, within the scope of this investigation, a feed-forward neural network comprising 10 hidden neurons was constructed and subjected to performance analysis in synthetic data testing. Remarkably, the optimal validation performance ascertained at epoch 4, attained a value of 0.55432. Furthermore, the Error-Target outputs for the PLC model were derived to discern variations across iterations for training, validation, testing, and zero errors, yielding the following values: 0.99687 for Training, 0.99115 for verification, 0.99571 for Testing, and 0.99575 for the aggregate dataset.

In conclusion, this article comprehensively reviews the utilization and effectiveness of machine learning-based methods for error correction codes and communication protocols in PLC systems. The findings highlight the potential of machine learning-based approaches to improve the performance and reliability of PLC systems. Consequently, further research and application in this domain will contribute to creating more efficient and reliable energy management, monitoring, and automation systems in the future.

## REFERENCES

- [1] J. P. A. Yaacoub, J. H. Fernandez, H. N. Noura, and A. Chehab, "Security of power line communication systems: Issues, limitations and existing solutions," *Comput. Sci. Rev.*, vol. 39, Feb. 2021, Art. no. 100331, doi: 10.1016/j.cosrev.2020.100331.
- [2] P. Mlýnek, M. Ruz, L. Beneš, J. Sláček, and P. Musil, "Possibilities of broadband power line communications for smart home and smart building applications," *Sensors*, vol. 21, no. 1, p. 240, Jan. 2021, doi: 10.3390/s21010240.
- [3] S. S. B. Sameon, S. Yusoff, and B. N. Jørgensen, "Comparison between communication technology used in smart building," in *Proc. 8th Int. Conf. Inf. Technol. Multimedia (ICIMU)*, Selangor, Malaysia, Aug. 2020, pp. 212–217, doi: 10.1109/ICIMU49871.2020.9243447.
- [4] S. Kirmani, A. Mazid, I. A. Khan, and M. Abid, "A survey on IoT-enabled smart grids: Technologies, architectures, applications, and challenges," *Sustainability*, vol. 15, no. 1, p. 717, Dec. 2022, doi: 10.3390/su15010717.
- [5] S. H. Mahmood, A. M. Salih, and M. I. Khalil, "Broadband services on power line communication systems: A review," in *Proc. 22nd Int. Conf. Control Syst. Comput. Sci. (CSCS)*, Bucharest, Romania, May 2019, pp. 465–470, doi: 10.1109/CSCS.2019.00085.
- [6] T. Zhang and W. Liu, "FFT-based OFDM in broadband-PLC and narrowband-PLC," in *Proc. Int. Conf. Cyber-Enabled Distrib. Comput. Knowl. Discovery*, Sanya, China, Oct. 2012, pp. 473–478, doi: 10.1109/CyberC.2012.86.
- [7] G. Prasad and L. Lampe, "Full-duplex power line communications: Design and applications from multimedia to smart grid," *IEEE Commun. Mag.*, vol. 58, no. 2, pp. 106–112, Feb. 2020, doi: 10.1109/MCOM.001.1900519.
- [8] E. C. Uwaezuoke and T. G. Swart, "Network attack analysis of an indoor power line communication network," in *Proc. IEEE Int. Symp. Power Line Commun. Appl. (ISPLC)*, Aachen, Germany, Oct. 2021, pp. 96–101, doi: 10.1109/ISPLC52837.2021.9628606.
- [9] M. Singh, A. Amruthakala, M. L. Sudheer, and A. S. Murthy, "Analysis of noise in broadband powerline communications (B-PLC) in frequency range of 150 kHz–30 MHz," in *Proc. 4th IEEE Uttar Pradesh Sect. Int. Conf. Electr., Comput. Electron. (UPCON)*, Mathura, India, Oct. 2017, pp. 101–106, doi: 10.1109/UPCON.2017.8251030.
- [10] S. T. Y. Alfalahi, A. A. Alkahtani, A. Q. Al-Shetwi, A. S. Al-Ogaili, A. A. Abbood, M. B. Mansor, and Y. Fazea, "Supraharmonics in power grid: Identification, standards, and measurement techniques," *IEEE Access*, vol. 9, pp. 103677–103690, 2021, doi: 10.1109/ACCESS.2021.3099013.
- [11] D. Joshi, D. Deb, and S. M. Muyeen, "Comprehensive review on electric propulsion system of unmanned aerial vehicles," *Frontiers Energy Res.*, vol. 10, May 2022, Art. no. 752012, doi: 10.3389/fenrg.2022.752012.
- [12] K. Sayed, A. Almutairi, N. Albagami, O. Alrumayh, A. G. Abo-Khalil, and H. Saleeb, "A review of DC–AC converters for electric vehicle applications," *Energies*, vol. 15, no. 3, p. 1241, Feb. 2022, doi: 10.3390/en15031241.
- [13] R. Sriharan, S. Dharaganthu, P. A. Francis, and G. Janakiraman, "A review on power line communication systems," *Int. J. Eng. Res. Technol.*, vol. 6, pp. 1–5, Apr. 2018, doi: 10.17577/ijertcon062.
- [14] L. Lampe and L. T. Berger, "Power line communications," in *Academic Press Library in Mobile and Wireless Communications*. Jan. 2016, pp. 621–659, doi: 10.1016/b978-0-12-398281-0.00016-8.
- [15] P. Rao and B. D. Deebak, "Role of power line communications in the smart grid: Applications, challenges, and research initiatives," in *Sustainable Networks in Smart Grid*. New York, NY, USA: Academic, Jan. 2022, pp. 73–98, doi: 10.1016/b978-0-323-85626-3.00001-6.
- [16] H. Habibzadeh, T. Soyata, B. Kantarci, A. Boukerche, and C. Kaptan, "Sensing, communication and security planes: A new challenge for a smart city system design," *Comput. Netw.*, vol. 144, pp. 163–200, Oct. 2018, doi: 10.1016/j.comnet.2018.08.001.
- [17] G. van de Kaa, T. Fens, J. Rezaei, D. Kaynak, Z. Hatun, and A. Tsilimeni-Archangelidi, "Realizing smart meter connectivity: Analyzing the competing technologies power line communication, mobile telephony, and radio frequency using the best worst method," *Renew. Sustain. Energy Rev.*, vol. 103, pp. 320–327, Apr. 2019, doi: 10.1016/j.rser.2018.12.035.
- [18] S. Vappangi and V. V. Mani, "A survey on the integration of visible light communication with power line communication: Conception, applications and research challenges," *Optik*, vol. 266, Sep. 2022, Art. no. 169582, doi: 10.1016/j.ijleo.2022.169582.
- [19] A. S. Menezes, Y. F. Coutinho, and M. V. Ribeiro, "Hybrid cooperative spectrum sensing for improving cognitive power line communication systems," *Comput. Electr. Eng.*, vol. 103, Oct. 2022, Art. no. 108286, doi: 10.1016/j.compeleceng.2022.108286.
- [20] X. Deng, L. Wang, J. Gui, P. Jiang, X. Chen, F. Zeng, and S. Wan, "A review of 6G autonomous intelligent transportation systems: Mechanisms, applications and challenges," *J. Syst. Archit.*, vol. 142, Sep. 2023, Art. no. 102929, doi: 10.1016/j.sysarc.2023.102929.
- [21] K. A. Abdulsalam, J. Adebisi, M. Emezirinwune, and O. Babatunde, "An overview and multicriteria analysis of communication technologies for smart grid applications," *e-Prime, Adv. Electr. Eng., Electron. Energy*, vol. 3, Mar. 2023, Art. no. 100121, doi: 10.1016/j.prime.2023.100121.

- [22] R. Kadel, K. Paudel, D. B. Guruge, and S. J. Halder, "Opportunities and challenges for error control schemes for wireless sensor networks: A review," *Electronics*, vol. 9, no. 3, p. 504, Mar. 2020, doi: [10.3390/electronics9030504](https://doi.org/10.3390/electronics9030504).
- [23] HardwareBee. (Oct. 3, 2021). *Understanding Power Line Communication*. Accessed: Jun. 2023. [Online]. Available: <https://hardwarebee.com/understanding-power-line-communication/>
- [24] Electronic Projects for Engineering Students. (May 17, 2020). *Power Line Carrier Communication: Circuit Diagram and Its Working*. Accessed: Jun. 2023. [Online]. Available: <https://www.elprocus.com/what-is-power-line-carrier-communication-working-its-applications/>
- [25] X. Yang, H. Zhang, Q. Xie, and S. Wang, "Methods for power line communication carrier equipment identity authentication and wiretapping equipment locating considering physical layer characteristics," *Energy Rep.*, vol. 9, pp. 628–637, Apr. 2023, doi: [10.1016/j.egy.2023.03.011](https://doi.org/10.1016/j.egy.2023.03.011).
- [26] Y. Chen, Q. Rao, M. Zhang, J. Xu, P. Zhan, and X. Li, "Research on EMI of UHV AC transmission line to power communication equipment along the line," in *Proc. 4th Inf. Commun. Technol. Conf. (ICTC)*, Nanjing, China, May 2023, pp. 178–182, doi: [10.1109/ICTC57116.2023.10154686](https://doi.org/10.1109/ICTC57116.2023.10154686).
- [27] C. U. Ndujuba, S. N. John, and O. Ogunseye, "Improving data transmission efficiency over power line communication (PLC) system using OFDM," *Int. J. Appl. Eng. Res.*, vol. 12, no. 5, 2017, Art. no. 705710.
- [28] X. Li, Z. Shi, X. Wang, and L. Lv, "Research on frequency resource allocation model for power line carrier service of integrated station, equipment and user," in *Proc. 7th Asia Conf. Power Electr. Eng. (ACPEE)*, Hangzhou, China, Apr. 2022, pp. 803–807, doi: [10.1109/ACPEE53904.2022.9783913](https://doi.org/10.1109/ACPEE53904.2022.9783913).
- [29] C. Xu, Z. Xiong, X. Kong, G. Zhao, and S. Yu, "A packet reception probability-based reliable routing protocol for 3D VANET," *IEEE Wireless Commun. Lett.*, vol. 9, no. 4, pp. 495–498, Apr. 2020.
- [30] S. Kasthala and R. Goru, "A review on power line communication and its applicability to cable fault monitoring," in *Proc. Int. Conf. Recent Trends Microelectron., Autom., Comput. Commun. Syst. (ICMACC)*, Hyderabad, India, Dec. 2022, pp. 212–217, doi: [10.1109/ICMACC54824.2022.10093617](https://doi.org/10.1109/ICMACC54824.2022.10093617).
- [31] C. Kotchasarn, "Performance analysis of broadband power line communications with OFDM transmission," in *Proc. 19th Int. Conf. Adv. Commun. Technol. (ICTACT)*, PyeongChang, South Korea, Feb. 2017, pp. 316–320, doi: [10.23919/ICTACT.2017.7890106](https://doi.org/10.23919/ICTACT.2017.7890106).
- [32] W. Song, J. Li, D. Duan, J. Li, and H. Liu, "Optimization of precoders and rate allocation for rate splitting multiple access over power line communication channel," *Energy Rep.*, vol. 8, pp. 507–513, Sep. 2022, doi: [10.1016/j.egy.2022.03.148](https://doi.org/10.1016/j.egy.2022.03.148).
- [33] O. Kolade, A. D. Familua, and L. Cheng, "Indoor amplify-and-forward power-line and visible light communication channel model based on a semi-hidden Markov model," *AEU, Int. J. Electron. Commun.*, vol. 124, Sep. 2020, Art. no. 153108, doi: [10.1016/j.aeu.2020.153108](https://doi.org/10.1016/j.aeu.2020.153108).
- [34] Y. Li, M. Zhang, X. Zhang, G. Li, and J. Lu, "An adaptive MIMO-OFDM modulation method for middle voltage power line communication," in *Proc. IEEE 20th Int. Conf. Commun. Technol. (ICCT)*, Nanning, China, Oct. 2020, pp. 203–207, doi: [10.1109/ICCT50939.2020.9295905](https://doi.org/10.1109/ICCT50939.2020.9295905).
- [35] S. Schaffenroth, H.-P. Schmidt, and A. Kölpin, "Mitigation of coloured impulsive noise in OFDM receiver," in *Proc. IEEE Int. Symp. Power Line Commun. Appl. (ISPLC)*, Aachen, Germany, Oct. 2021, pp. 43–48, doi: [10.1109/ISPLC52837.2021.9628650](https://doi.org/10.1109/ISPLC52837.2021.9628650).
- [36] M. Kashef, M. Abdallah, and N. Al-Dhahir, "Transmit power optimization for a hybrid PLC/VLC/RF communication system," *IEEE Trans. Green Commun. Netw.*, vol. 2, no. 1, pp. 234–245, Mar. 2018, doi: [10.1109/TGCN.2017.2774104](https://doi.org/10.1109/TGCN.2017.2774104).
- [37] Y. Liao, W. Li, K. Wang, J. Guo, Y. Shen, Q. Wang, Y. Zhang, C. Wu, X. Zhou, T. Guo, and T. W. Kim, "TENG-inspired LED-in-capacitors for smart self-powered high-voltage monitoring and high-sensitivity demodulation of power-line communications," *Nano Energy*, vol. 102, Nov. 2022, Art. no. 107698, doi: [10.1016/j.nanoen.2022.107698](https://doi.org/10.1016/j.nanoen.2022.107698).
- [38] G. Cao, X. Zhang, P. Li, F. Li, Y. Liu, and Z. Wu, "Load frequency regulation of multi-area power systems with communication delay via cascaded improved ADRC," *Energy Rep.*, vol. 9, pp. 983–991, Sep. 2023, doi: [10.1016/j.egy.2023.04.379](https://doi.org/10.1016/j.egy.2023.04.379).
- [39] E. F. Fuchs and M. A. S. Masoum, "Impact of poor power quality on reliability, relaying, and security," in *Power Quality in Power Systems, Electrical Machines, and Power-Electronic Drives*. New York, NY, USA: Academic, Jan. 2023, pp. 805–913, doi: [10.1016/b978-0-12-817856-0.00009-1](https://doi.org/10.1016/b978-0-12-817856-0.00009-1).
- [40] B. Li, P. Zhang, and Y. Liang, "Research on power communication mode under the architecture of mountain microgrid," in *Proc. 7th Int. Conf. Comput. Commun. Syst. (ICCCS)*, Wuhan, China, Apr. 2022, pp. 802–806, doi: [10.1109/ICCCS55155.2022.9845901](https://doi.org/10.1109/ICCCS55155.2022.9845901).
- [41] F. Fang and Z. Yang, "Adaptive suppression algorithm of narrow-band interference for OFDM-based power line communications," in *Proc. 5th Int. Conf. Comput. Sci. Netw. Technol. (ICCSNT)*, Dec. 2016, pp. 461–466.
- [42] Y. Liang, Z. Shi, X. Wang, and Z. Wu, "Research on optimization of modulation and coding mode for power line carrier communication," in *Proc. 4th Int. Conf. Adv. Comput. Technol., Inf. Sci. Commun. (CTISC)*, Suzhou, China, Apr. 2022, pp. 1–5, doi: [10.1109/CTISC54888.2022.9849752](https://doi.org/10.1109/CTISC54888.2022.9849752).
- [43] L. G. de Oliveira, G. R. Colen, M. V. Ribeiro, and A. J. H. Vinck, "Narrow-band interference error correction in coded OFDM-based PLC systems," in *Proc. Int. Symp. Power Line Commun. Appl. (ISPLC)*, Bottrop, Germany, Mar. 2016, pp. 13–18, doi: [10.1109/ISPLC.2016.7476279](https://doi.org/10.1109/ISPLC.2016.7476279).
- [44] *IEEE Standard for low-Frequency (Less Than 500 kHz) Narrowband Power Line Communications for Smart Grid Applications*, IEEE Standard 1901.2, Dec. 2013.
- [45] M. Liu, W. Lei, J. Sun, H. Lei, and H. Tang, "Power and rate control in wireless communication systems with energy harvesting and rateless codes," *Phys. Commun.*, vol. 59, Aug. 2023, Art. no. 102083, doi: [10.1016/j.phycom.2023.102083](https://doi.org/10.1016/j.phycom.2023.102083).
- [46] M. A. N. S. Raghavendra and U. S. Acharya, "Index modulation aided multi carrier power line communication employing rank codes from cyclic codes," *Phys. Commun.*, vol. 39, Apr. 2020, Art. no. 100975, doi: [10.1016/j.phycom.2019.100975](https://doi.org/10.1016/j.phycom.2019.100975).
- [47] A. Chattopadhyay, K. Sharma, and A. Chandra, "Error performance of RS coded binary FSK in PLC channels with Nakagami and impulsive noise," in *Proc. 18th IEEE Int. Symp. Power Line Commun. Appl.*, Glasgow, U.K., Mar. 2014, pp. 184–189, doi: [10.1109/ISPLC.2014.6812369](https://doi.org/10.1109/ISPLC.2014.6812369).
- [48] E.-H. Lu, T.-C. Chen, and P.-Y. Lu, "A new method for evaluating error magnitudes of Reed–Solomon codes," *IEEE Commun. Lett.*, vol. 18, no. 2, pp. 340–343, Feb. 2014, doi: [10.1109/LCOMM.2013.122713.132334](https://doi.org/10.1109/LCOMM.2013.122713.132334).
- [49] X. Wang, H. Hong, K. Wang, Y. Li, Q. Guo, Y. Zhang, and Q. Yang, "Performance of LDPC and turbo coded power line communication over multipath channel and narrowband noise," in *Proc. 2nd Asia-Pacific Conf. Commun. Technol. Comput. Sci. (ACCTCS)*, Shenyang, China, Feb. 2022, pp. 263–269, doi: [10.1109/ACCTCS53867.2022.00061](https://doi.org/10.1109/ACCTCS53867.2022.00061).
- [50] *IEEE Standard for Information Technology—Telecommunications and Information Exchange Between Systems—Local and Metropolitan Area Networks—Specific Requirements—Part 11: Wireless LAN Medium Access Control (MAC) and Physical Layer (PHY) Specifications—Redline*, IEEE Standard 802.11-2020 (Revision of IEEE Standard 802.11-2016), Feb. 2021, pp. 1–7524.
- [51] C. Panem, V. Gad, and R. S. Gad, "Polynomials in error detection and correction in data communication system," in *Coding Theory*. London, U.K.: IntechOpen, Mar. 2020, pp. 29–49, doi: [10.5772/intechopen.86160](https://doi.org/10.5772/intechopen.86160).
- [52] S. Ahmed, D. G. Lee, J. Yong, J. Kurone-Ghariban, C. J. Matchinsky, T. Kester, M. Cha, S. Dobbs, and Z. Yu, "Implementation and investigation of high endurance UAVs in a 4G LTE network for monitoring power lines," in *Proc. Wireless Telecommun. Symp. (WTS)*, Boston, MA, USA, Apr. 2023, pp. 1–9, doi: [10.1109/WTS202356685.2023.10131813](https://doi.org/10.1109/WTS202356685.2023.10131813).
- [53] M. Park, G. Jeong, H. Son, and J. Paek, "Performance of RPL routing protocol over multihop power line communication network," in *Proc. Int. Conf. Inf. Commun. Technol. Conver. (ICTC)*, Jeju, South Korea, Oct. 2020, pp. 1918–1920, doi: [10.1109/ICTC49870.2020.9289175](https://doi.org/10.1109/ICTC49870.2020.9289175).
- [54] A. Dua, V. Jindal, and P. Bedi, "Covert communication using address resolution protocol broadcast request messages," in *Proc. 9th Int. Conf. Rel., Infocom Technol. Optim. (Trends Future Directions) (ICRITO)*, Noida, India, Sep. 2021, pp. 1–6, doi: [10.1109/ICRITO51393.2021.9596480](https://doi.org/10.1109/ICRITO51393.2021.9596480).
- [55] N. Wehbe, H. A. Alameddine, M. Pourzandi, E. Bou-Harb, and C. Assi, "A security assessment of HTTP/2 usage in 5G service-based architecture," *IEEE Commun. Mag.*, vol. 61, no. 1, pp. 48–54, Jan. 2023, doi: [10.1109/MCOM.001.2200183](https://doi.org/10.1109/MCOM.001.2200183).
- [56] M. Selvi, A. Gayathri, S. K. Svn, and A. Kannan, "Energy efficient and secured MQTT protocol using IoT," *Int. J. Innov. Technol. Exploring Eng.*, vol. 9, no. 4, pp. 11–14, Feb. 2020, doi: [10.35940/ijitee.b6264.029420](https://doi.org/10.35940/ijitee.b6264.029420).

- [57] G. S. Karthick, "Energy-aware reliable medium access control protocol for energy-efficient and reliable data communication in wireless sensor networks," *Social Netw. Comput. Sci.*, vol. 4, no. 5, Jun. 2023, Art. no. 449, doi: [10.1007/s42979-023-01869-z](https://doi.org/10.1007/s42979-023-01869-z).
- [58] A. H. Beshir, S. Negri, X. Wu, X. Liu, L. Wan, G. Spadacini, S. A. Pignari, and F. Grassi, "Behavioral model of G3-powerline communication modems for EMI analysis," *Energies*, vol. 16, no. 8, p. 3336, Apr. 2023, doi: [10.3390/en16083336](https://doi.org/10.3390/en16083336).
- [59] M. Brandl and K. Kellner, "Performance evaluation of power-line communication systems for LIN-bus based data transmission," *Electronics*, vol. 10, no. 1, p. 85, Jan. 2021, doi: [10.3390/electronics10010085](https://doi.org/10.3390/electronics10010085).
- [60] L. Lampe, A. M. Tonello, and T. G. Swart, *Power Line Communications: Principles, Standards and Applications from Multimedia to Smart Grid*. Chichester, U.K.: Wiley, 2016.
- [61] H. C. Ferreira, L. Lampe, J. Newbury, and T. G. Swart, *Power Line Communications*. Hoboken, NJ, USA: Wiley, 2011.
- [62] J. Anatory and N. Theethayi, *Broadband Power-Line Communication Systems: Theory & Applications*. Boston, MA, USA: WIT, 2010.
- [63] E. Conrad, S. Misener, and J. Feldman, "Domain 4: Communication and network security," in *CISSP Study Guide*. Amsterdam, The Netherlands: Elsevier, Jan. 2023, pp. 225–293, doi: [10.1016/b978-0-443-18734-6.00003-9](https://doi.org/10.1016/b978-0-443-18734-6.00003-9).
- [64] M. Sanz, J. I. Moreno, G. López, J. Matanza, and J. Berrocal, "Web-based toolkit for performance simulation and analysis of power line communication networks," *Energies*, vol. 14, no. 20, p. 6475, Oct. 2021, doi: [10.3390/en14206475](https://doi.org/10.3390/en14206475).
- [65] Y. Huo, G. Prasad, L. Lampe, and C. M. V. Leung, "Smart-grid monitoring: Enhanced machine learning for cable diagnostics," in *Proc. IEEE Int. Symp. Power Line Commun. Appl. (ISPLC)*, Prague, Czech Republic, Apr. 2019, pp. 1–6, doi: [10.1109/ISPLC.2019.8693287](https://doi.org/10.1109/ISPLC.2019.8693287).
- [66] A. M. Tonello, N. A. Letizia, D. Righini, and F. Marcuzzi, "Machine learning tips and tricks for power line communications," *IEEE Access*, vol. 7, pp. 82434–82452, 2019, doi: [10.1109/ACCESS.2019.2923321](https://doi.org/10.1109/ACCESS.2019.2923321).
- [67] O. Simeone, "A very brief introduction to machine learning with applications to communication systems," *IEEE Trans. Cogn. Commun. Netw.*, vol. 4, no. 4, pp. 648–664, Dec. 2018.
- [68] N. A. Letizia and A. M. Tonello, "Capacity learning for communication systems over power lines," in *Proc. IEEE Int. Symp. Power Line Commun. Appl. (ISPLC)*, Aachen, Germany, Oct. 2021, pp. 55–60, doi: [10.1109/ISPLC52837.2021.9628415](https://doi.org/10.1109/ISPLC52837.2021.9628415).
- [69] C. Yang and Z. Zhang, "Intelligent home system design based on power line communication," in *Proc. 2nd Int. Conf. Telecommun. Commun. Eng.*, Nov. 2018, pp. 334–338, doi: [10.1145/3291842.3291852](https://doi.org/10.1145/3291842.3291852).
- [70] M.-S. Koh, "An end-to-end trainable power line communication system," in *Proc. 8th Int. Conf. Mach. Learn. Technol.*, Mar. 2023, pp. 257–263, doi: [10.1145/3589883.3589922](https://doi.org/10.1145/3589883.3589922).
- [71] N. Nayakwadi and R. Fatima, "Machine learning based handover execution algorithm for heterogeneous wireless networks," in *Proc. 5th Int. Conf. Res. Comput. Intell. Commun. Netw. (ICRCICN)*, Bengaluru, India, Nov. 2020, pp. 54–58, doi: [10.1109/ICRCICN50933.2020.9296169](https://doi.org/10.1109/ICRCICN50933.2020.9296169).
- [72] F. Nisar and S. Baseer, "A comprehensive survey on mobile communication generation," in *Proc. Int. Conf. Innov. Comput. (ICIC)*, Lahore, Pakistan, Nov. 2021, pp. 1–6, doi: [10.1109/ICIC53490.2021.9692972](https://doi.org/10.1109/ICIC53490.2021.9692972).
- [73] P. Liu, J. Luo, H. Liang, and Z. Wen, "Intelligent monitoring model of Internet of Things for power transmission corridor status in bad environment area," in *Proc. 13th Int. Conf. Measuring Technol. Mechatronics Autom. (ICMTMA)*, Beihai, China, Jan. 2021, pp. 188–192, doi: [10.1109/ICMTMA52658.2021.00049](https://doi.org/10.1109/ICMTMA52658.2021.00049).
- [74] G. Kumari and C. Selwal, "System analysis for optical inter-satellite link with varied parameter and pre-amplification," in *Proc. Int. Conf. Adv. Comput., Commun. Informat. (ICACCI)*, Jaipur, India, Sep. 2016, pp. 2157–2161, doi: [10.1109/ICACCI.2016.7732371](https://doi.org/10.1109/ICACCI.2016.7732371).
- [75] M. S. Ibrahim, W. Dong, and Q. Yang, "Machine learning driven smart electric power systems: Current trends and new perspectives," *Appl. Energy*, vol. 272, Aug. 2020, Art. no. 115237, doi: [10.1016/j.apenergy.2020.115237](https://doi.org/10.1016/j.apenergy.2020.115237).
- [76] S. A. A. Kazmi and M. S. Iqbal, "Machine learning assisted delay minimization in full duplex energy constrained cooperative communication network," *Ad Hoc Netw.*, vol. 149, May 2023, Art. no. 103208, doi: [10.1016/j.adhoc.2023.103208](https://doi.org/10.1016/j.adhoc.2023.103208).
- [77] I. H. Sarker, "Machine learning: Algorithms, real-world applications and research directions," *Social Netw. Comput. Sci.*, vol. 2, no. 3, pp. 1–21, Mar. 2021, doi: [10.1007/s42979-021-00592-x](https://doi.org/10.1007/s42979-021-00592-x).
- [78] Y. Zhang, T. Huang, and E. F. Bompard, "Big data analytics in smart grids: A review," *Energy Informat.*, vol. 1, no. 1, Aug. 2018, Art. no. 8, doi: [10.1186/s42162-018-0007-5](https://doi.org/10.1186/s42162-018-0007-5).
- [79] C. Liu, Z. H. Rather, Z. Chen, and C. L. Bak, "An overview of decision tree applied to power systems," *Int. J. Smart Grid Clean Energy*, vol. 2, no. 3, pp. 413–419, 2013, doi: [10.12720/sgece.2.3.413-419](https://doi.org/10.12720/sgece.2.3.413-419).
- [80] M. Bonavita and P. Laloyaux, "Machine learning for model error inference and correction," *J. Adv. Model. Earth Syst.*, vol. 12, no. 12, Nov. 2020, Art. no. e2020MS002232, doi: [10.1029/2020ms002232](https://doi.org/10.1029/2020ms002232).
- [81] I. H. Sarker, "Deep learning: A comprehensive overview on techniques, taxonomy, applications and research directions," *Social Netw. Comput. Sci.*, vol. 2, no. 6, Aug. 2021, Art. no. 420, doi: [10.1007/s42979-021-00815-1](https://doi.org/10.1007/s42979-021-00815-1).
- [82] N. Jariwala, C. L. Putta, K. Gatade, M. Umarji, S. N. R. Rahman, D. M. Pawde, A. Sree, A. S. Kamble, A. Goswami, P. Chakraborty, and T. Shunmugaperumal, "Intriguing of pharmaceutical product development processes with the help of artificial intelligence and deep/machine learning or artificial neural network," *J. Drug Del. Sci. Technol.*, vol. 87, Sep. 2023, Art. no. 104751, doi: [10.1016/j.jddst.2023.104751](https://doi.org/10.1016/j.jddst.2023.104751).
- [83] H. Chang, X. Liang, H. Li, J. Shen, X. Gu, and L. Zhang, "Deep learning-based bitstream error correction for CSI feedback," *IEEE Wireless Commun. Lett.*, vol. 10, no. 12, pp. 2828–2832, Dec. 2021, doi: [10.1109/LWC.2021.3118923](https://doi.org/10.1109/LWC.2021.3118923).
- [84] R. Zhang, G. Li, S. Bu, G. Kuang, W. He, Y. Zhu, and S. Aziz, "A hybrid deep learning model with error correction for photovoltaic power forecasting," *Frontiers Energy Res.*, vol. 10, Aug. 2022, Art. no. 948308, doi: [10.3389/fenrg.2022.948308](https://doi.org/10.3389/fenrg.2022.948308).
- [85] L. D. Colomer, M. Skotiniotis, and R. Muñoz-Tapia, "Reinforcement learning for optimal error correction of toric codes," *Phys. Lett. A*, vol. 384, no. 17, Jun. 2020, Art. no. 126353, doi: [10.1016/j.physleta.2020.126353](https://doi.org/10.1016/j.physleta.2020.126353).
- [86] R. Gholami and N. Fakhari, "Support vector machine: Principles, parameters, and applications," in *Handbook of Neural Computation*. New York, NY, USA: Academic, 2017, pp. 515–535, doi: [10.1016/b978-0-12-811318-9.00027-2](https://doi.org/10.1016/b978-0-12-811318-9.00027-2).
- [87] S. Ghosh, A. Dasgupta, and A. Swetapadma, "A study on support vector machine based linear and non-linear pattern classification," in *Proc. Int. Conf. Intell. Sustain. Syst. (ICISS)*, Palladam, India, Feb. 2019, pp. 24–28, doi: [10.1109/ISSI.2019.8908018](https://doi.org/10.1109/ISSI.2019.8908018).
- [88] S. Huang, J. Huang, Y. Ou, W. Ruan, J. Lin, X. Peng, and X. Wang, "Transmission line faults classification based on alienation coefficients of current and voltage waveform and SVM," in *Proc. 5th Asia Conf. Power Electr. Eng. (ACPEE)*, Chengdu, China, Jun. 2020, pp. 60–64, doi: [10.1109/ACPEE48638.2020.9136270](https://doi.org/10.1109/ACPEE48638.2020.9136270).
- [89] J. Xie, A. P. S. Meliopoulos, and B. Xie, "Transmission line fault classification based on dynamic state estimation and support vector machine," in *Proc. North Amer. Power Symp. (NAPS)*, Fargo, ND, USA, Sep. 2018, pp. 1–5, doi: [10.1109/NAPS.2018.8600658](https://doi.org/10.1109/NAPS.2018.8600658).
- [90] A. S. Nagane, C. H. Patil, and S. M. Mali, "Classification of brahmi script characters using HOG features and multiclass error-correcting output codes (ECOC) model containing SVM binary learners," in *Proc. Int. Conf. Intell. Innov. Technol. Comput., Electr. Electron. (IITCEE)*, Bengaluru, India, Jan. 2023, pp. 448–451, doi: [10.1109/IITCEE57236.2023.10091084](https://doi.org/10.1109/IITCEE57236.2023.10091084).
- [91] C. Shu, C. Yang, and P. An, "An online SVM based VVC intra fast partition algorithm with pre-scene-cut detection," in *Proc. IEEE Int. Symp. Circuits Syst. (ISCAS)*, Austin, TX, USA, May 2022, pp. 3033–3037, doi: [10.1109/ISCAS48785.2022.9937410](https://doi.org/10.1109/ISCAS48785.2022.9937410).
- [92] P. Santos, L. Villa, A. Reñones, A. Bustillo, and J. Maudes, "An SVM-based solution for fault detection in wind turbines," *Sensors*, vol. 15, no. 3, pp. 5627–5648, Mar. 2015, doi: [10.3390/s150305627](https://doi.org/10.3390/s150305627).
- [93] M. Awad and R. Khanna, "Support vector machines for classification," in *Efficient Learning Machines*. Amsterdam, The Netherlands: Elsevier, 2015, pp. 39–66, doi: [10.1007/978-1-4302-5990-9\\_3](https://doi.org/10.1007/978-1-4302-5990-9_3).
- [94] Y. Shen, J. Ruijsch, M. Lu, E. H. Sutanudjaja, and D. Karssenbergh, "Random forests-based error-correction of streamflow from a large-scale hydrological model: Using model state variables to estimate error terms," *Comput. Geosci.*, vol. 159, Feb. 2022, Art. no. 105019, doi: [10.1016/j.cageo.2021.105019](https://doi.org/10.1016/j.cageo.2021.105019).
- [95] X. Chen and H. Ishwaran, "Random forests for genomic data analysis," *Genomics*, vol. 99, no. 6, pp. 323–329, Jun. 2012, doi: [10.1016/j.ygeno.2012.04.003](https://doi.org/10.1016/j.ygeno.2012.04.003).
- [96] G. Biau, "Analysis of a random forests model," *J. Mach. Learn. Res.*, vol. 13, pp. 1063–1095, Apr. 2012.

- [97] H. Taherdoost, "Blockchain and machine learning: A critical review on security," *Information*, vol. 14, no. 5, p. 295, May 2023, doi: [10.3390/info14050295](https://doi.org/10.3390/info14050295).
- [98] A. Gerodimos, L. Maglaras, M. A. Ferrag, N. Ayres, and I. Kantzavelou, "IoT: Communication protocols and security threats," *Internet Things Cyber-Phys. Syst.*, vol. 3, pp. 1–13, Jan. 2023, doi: [10.1016/j.iotcps.2022.12.003](https://doi.org/10.1016/j.iotcps.2022.12.003).
- [99] M. I. Tariq, N. A. Memon, S. Ahmed, S. Tayyaba, M. T. Mushtaq, N. A. Mian, M. Imran, and M. W. Ashraf, "A review of deep learning security and privacy defensive techniques," *Mobile Inf. Syst.*, vol. 2020, pp. 1–18, Apr. 2020, doi: [10.1155/2020/6535834](https://doi.org/10.1155/2020/6535834).
- [100] C. Wen, D. Dematties, and S.-L. Zhang, "A guide to signal processing algorithms for nanopore sensors," *ACS Sensors*, vol. 6, no. 10, pp. 3536–3555, Oct. 2021, doi: [10.1021/acssensors.1c01618](https://doi.org/10.1021/acssensors.1c01618).
- [101] R. Maskeliūnas, R. Pomarnacki, V. K. Huynh, R. Damaševičius, and D. Plonis, "Power line monitoring through data integrity analysis with Q-learning based data analysis network," *Remote Sens.*, vol. 15, no. 1, p. 194, Dec. 2022, doi: [10.3390/rs15010194](https://doi.org/10.3390/rs15010194).
- [102] X. Huang, T. Hu, C. Ye, G. Xu, X. Wang, and L. Chen, "Electric load data compression and classification based on deep stacked auto-encoders," *Energies*, vol. 12, no. 4, p. 653, Feb. 2019, doi: [10.3390/en12040653](https://doi.org/10.3390/en12040653).
- [103] N. Rajkumar and E. Kannan, "Deep learning-based key transmission (DLKT) protocol for secured group communication in cloud," *Soft Comput.*, vol. 25, no. 16, pp. 10709–10721, Jul. 2021, doi: [10.1007/s00500-021-05959-z](https://doi.org/10.1007/s00500-021-05959-z).
- [104] *A Complete Overview of IoT Communication Protocols | Expanice*. Accessed: Jul. 2023. [Online]. Available: <https://expanice.com/article/iot-communication-protocols-comparison>
- [105] H. Lin, W.-Y. Shin, and J. Joung, "Support vector machine-based transmit antenna allocation for multiuser communication systems," *Entropy*, vol. 21, no. 5, p. 471, May 2019, doi: [10.3390/e21050471](https://doi.org/10.3390/e21050471).
- [106] R. K. Satyanarayana and K. Selvakumar, "Bi-linear mapping integrated machine learning based authentication routing protocol for improving quality of service in vehicular ad-hoc network," *e-Prime, Adv. Electr. Eng., Electron. Energy*, vol. 4, Jun. 2023, Art. no. 100145, doi: [10.1016/j.prime.2023.100145](https://doi.org/10.1016/j.prime.2023.100145).
- [107] S. D. D. Anton, S. Sinha, and H. D. Schotten, "Anomaly-based intrusion detection in industrial data with SVM and random forests," 2019, *arXiv:1907.10374*. Accessed: Jul. 29, 2023.
- [108] M. D. Lal and R. Varadarajan, "A review of machine learning approaches in synchrophasor technology," *IEEE Access*, vol. 11, pp. 33520–33541, 2023, doi: [10.1109/ACCESS.2023.3263547](https://doi.org/10.1109/ACCESS.2023.3263547).
- [109] A. Alayil, P. Sarkar, D. Bose, and C. K. Chanda, "Prediction of power outage during cyclone using machine learning," in *Proc. IEEE Calcutta Conf. (CALCON)*, Kolkata, India, Dec. 2022, pp. 255–260, doi: [10.1109/CALCON56258.2022.10060493](https://doi.org/10.1109/CALCON56258.2022.10060493).
- [110] X. Tang, P. Reviriego, W. Tang, D. G. M. Mitchell, F. Lombardi, and S. Liu, "Joint learning and channel coding for error-tolerant IoT systems based on machine learning," *IEEE Trans. Artif. Intell.*, early access, Jan. 10, 2023, doi: [10.1109/TAI.2023.3235778](https://doi.org/10.1109/TAI.2023.3235778).
- [111] S. Liu, P. Reviriego, X. Tang, W. Tang, and F. Lombardi, "Result-based re-computation for error-tolerant classification by a support vector machine," *IEEE Trans. Artif. Intell.*, vol. 1, no. 1, pp. 62–73, Aug. 2020, doi: [10.1109/TAI.2020.3028321](https://doi.org/10.1109/TAI.2020.3028321).
- [112] P. Mlynek, J. Misurec, P. Silhavy, R. Fudjak, J. Slacik, and Z. Hasirci, "Simulation of achievable data rates of broadband power line communication for smart metering," *Appl. Sci.*, vol. 9, no. 8, p. 1527, Apr. 2019, doi: [10.3390/app9081527](https://doi.org/10.3390/app9081527).
- [113] D. Liang, S. Ge, H. Guo, Y. Wang, Z. Liang, and C. Chen, "Monitoring power line faults using impedance estimation algorithms in power line communication equipment," in *Proc. 10th Int. Conf. Power Energy Syst. (ICPES)*, Chengdu, China, Dec. 2020, pp. 404–408, doi: [10.1109/ICPES51309.2020.9349656](https://doi.org/10.1109/ICPES51309.2020.9349656).
- [114] Z. Shi, J. Lu, and B. Li, "Research on power line carrier communication channel modeling for power distribution and consumption IoT," in *Proc. 3rd Int. Conf. Comput. Vis., Image Deep Learn. Int. Conf. Comput. Eng. Appl. (CVIDL ICCEA)*, Changchun, China, May 2022, pp. 322–325, doi: [10.1109/CVIDLICCEA56201.2022.9824830](https://doi.org/10.1109/CVIDLICCEA56201.2022.9824830).
- [115] J. P. A. León, L. J. de la Cruz Llopis, and F. J. Rico-Novella, "A machine learning based distributed congestion control protocol for multi-hop wireless networks," *Comput. Netw.*, vol. 231, Jul. 2023, Art. no. 109813, doi: [10.1016/j.comnet.2023.109813](https://doi.org/10.1016/j.comnet.2023.109813).
- [116] J. Chen, H. Chen, and Z. Li, "A double serial concatenated code using CRC-aided error correction for highly reliable communication," *Comput. Netw.*, vol. 216, Oct. 2022, Art. no. 109260, doi: [10.1016/j.comnet.2022.109260](https://doi.org/10.1016/j.comnet.2022.109260).
- [117] P. Ledesma, D. Gotti, and H. Amaris, "Co-simulation platform for interconnected power systems and communication networks based on PSS/E and OMNeT++," *Comput. Electr. Eng.*, vol. 101, Jul. 2022, Art. no. 108092, doi: [10.1016/j.compeleceng.2022.108092](https://doi.org/10.1016/j.compeleceng.2022.108092).
- [118] E. A. A. Alaoui, S. C. K. Tekouabou, Y. Maleh, and A. Nayyar, "Towards to intelligent routing for DTN protocols using machine learning techniques," *Simul. Model. Pract. Theory*, vol. 117, May 2022, Art. no. 102475, doi: [10.1016/j.simpact.2021.102475](https://doi.org/10.1016/j.simpact.2021.102475).
- [119] M. A. Kippke, "Technologies for data collection in power systems," in *Encyclopedia of Electrical and Electronic Power Engineering*. Amsterdam, The Netherlands: Elsevier, Jan. 2023, pp. 320–326, doi: [10.1016/b978-0-12-821204-2.00063-5](https://doi.org/10.1016/b978-0-12-821204-2.00063-5).
- [120] Y. Li, T. Bao, Z. Chen, Z. Gao, X. Shu, and K. Zhang, "A missing sensor measurement data reconstruction framework powered by multi-task Gaussian process regression for dam structural health monitoring systems," *Measurement*, vol. 186, Dec. 2021, Art. no. 110085, doi: [10.1016/j.measurement.2021.110085](https://doi.org/10.1016/j.measurement.2021.110085).
- [121] D. DeBonis, T. Estrada, R. E. Grant, K. T. Pedretti, J. H. Laros, III, and D. Arnold, "APE: Metrics for understanding application performance efficiency under power caps," *Sustain. Comput., Informat. Syst.*, vol. 34, Apr. 2022, Art. no. 100702, doi: [10.1016/j.suscom.2022.100702](https://doi.org/10.1016/j.suscom.2022.100702).
- [122] H. Sheng, H. Y. Zhang, F. Yang, C. H. Li, and J. Wang, "A CSMA/CA based MAC protocol for hybrid power-line/visible-light communication networks: Design and analysis," *Digit. Commun. Netw.*, Oct. 2022, doi: [10.1016/j.dcan.2022.09.019](https://doi.org/10.1016/j.dcan.2022.09.019).
- [123] M. Wolkerstorfer, B. Schweighofer, H. Wegleiter, D. Statovci, H. Schwaiger, and W. Lackner, "Measurement and simulation framework for throughput evaluation of narrowband power line communication links in low-voltage grids," *J. Netw. Comput. Appl.*, vol. 59, pp. 285–300, Jan. 2016, doi: [10.1016/j.jnca.2015.05.022](https://doi.org/10.1016/j.jnca.2015.05.022).
- [124] F. Krajcovic, M. Krajmer, M. Lipovsky, M. Majchrak, and P. Podhoransky, "Investigation of harmful interference to power line communication bit rate," in *Proc. 19th Int. Conf. Radioelektronika*, Bratislava, Slovakia, Apr. 2009, pp. 51–55, doi: [10.1109/RADIOELEK.2009.5158723](https://doi.org/10.1109/RADIOELEK.2009.5158723).
- [125] B. Yue, Z. Wei, C. Zheng, Y. Ding, B. Li, D. Li, X. Liang, and X. Zhai, "Power consumption prediction of variable refrigerant flow system through data-physics hybrid approach: An online prediction test in office building," *Energy*, vol. 278, Sep. 2023, Art. no. 127826, doi: [10.1016/j.energy.2023.127826](https://doi.org/10.1016/j.energy.2023.127826).
- [126] C. Huo, J. Yuan, G. Song, and Z. Shi, "Node reliability based multi-path routing algorithm of high-speed power line communication network," in *Proc. IEEE 4th Int. Conf. Cloud Comput. Big Data Anal. (ICC-CBDA)*, Chengdu, China, Apr. 2019, pp. 570–573, doi: [10.1109/ICC-CBDA.2019.8725798](https://doi.org/10.1109/ICC-CBDA.2019.8725798).
- [127] A. H. K. S. A. Saidi, S. A. Hussain, S. M. Hussain, A. V. Singh, and A. Rana, "Smart water meter using power line communication (PLC) approach for measurements of accurate water consumption and billing process," in *Proc. 8th Int. Conf. Rel., Infocom Technol. Optim. (Trends Future Directions) (ICRITO)*, Noida, India, Jun. 2020, pp. 1119–1122, doi: [10.1109/ICRITO48877.2020.9197956](https://doi.org/10.1109/ICRITO48877.2020.9197956).
- [128] H. Chiroma, P. Nickolas, N. Faruk, E. Alozie, I.-F.-Y. Olayinka, K. S. Adewole, A. Abdulkarim, A. A. Oloyede, O. A. Sowande, S. Garba, A. D. Usman, L. S. Taura, and Y. A. Adediran, "Large scale survey for radio propagation in developing machine learning model for path losses in communication systems," *Sci. Afr.*, vol. 19, Mar. 2023, Art. no. e01550, doi: [10.1016/j.sciaf.2023.e01550](https://doi.org/10.1016/j.sciaf.2023.e01550).
- [129] S. Singh, A. Trivedi, and D. Saxena, "Unsupervised LoS/NLoS identification in mmWave communication using two-stage machine learning framework," *Phys. Commun.*, vol. 59, May 2023, Art. no. 102118, doi: [10.1016/j.phycom.2023.102118](https://doi.org/10.1016/j.phycom.2023.102118).
- [130] A. Kumbhar, P. G. Dhawale, S. Kumbhar, U. Patil, and P. Magdum, "A comprehensive review: Machine learning and its application in integrated power system," *Energy Rep.*, vol. 7, pp. 5467–5474, Nov. 2021, doi: [10.1016/j.egyrs.2021.08.133](https://doi.org/10.1016/j.egyrs.2021.08.133).
- [131] M. Farhoumandi, Q. Zhou, and M. Shahidehpour, "A review of machine learning applications in IoT-integrated modern power systems," *Electr. J.*, vol. 34, no. 1, Jan. 2021, Art. no. 106879, doi: [10.1016/j.tej.2020.106879](https://doi.org/10.1016/j.tej.2020.106879).

- [132] P. Sanjeevikumar, T. Samavat, M. A. Nasab, M. Zand, and M. Khoobani, "Machine learning-based hybrid demand-side controller for renewable energy management," in *Sustainable Developments by Artificial Intelligence and Machine Learning for Renewable Energies*. Amsterdam, The Netherlands: Elsevier, Jan. 2022, pp. 291–307, doi: [10.1016/b978-0-323-91228-0.00003-3](https://doi.org/10.1016/b978-0-323-91228-0.00003-3).
- [133] T. Kaneko, R. Wada, M. Ozaki, and T. Inoue, "Hybrid physics-based and machine learning model with interpretability and uncertainty for real-time estimation of unmeasurable parts," *Ocean Eng.*, vol. 284, Sep. 2023, Art. no. 115267, doi: [10.1016/j.oceaneng.2023.115267](https://doi.org/10.1016/j.oceaneng.2023.115267).
- [134] N. A. Azhar, N. A. M. Radzi, K. H. M. Azmi, F. S. Samidi, and A. M. Zainal, "Criteria selection using machine learning (ML) for communication technology solution of electrical distribution substations," *Appl. Sci.*, vol. 12, no. 8, p. 3878, Apr. 2022, doi: [10.3390/app12083878](https://doi.org/10.3390/app12083878).
- [135] L. Pereira and N. Nunes, "An empirical exploration of performance metrics for event detection algorithms in non-intrusive load monitoring," *Sustain. Cities Soc.*, vol. 62, Nov. 2020, Art. no. 102399, doi: [10.1016/j.scs.2020.102399](https://doi.org/10.1016/j.scs.2020.102399).
- [136] S.-M. Tseng, W.-C. Hsu, and D.-F. Tseng, "Deep learning based decoding for polar codes in Markov Gaussian memory impulse noise channels," *Wireless Pers. Commun.*, vol. 122, no. 1, pp. 737–753, Aug. 2021, doi: [10.1007/s11277-021-08923-0](https://doi.org/10.1007/s11277-021-08923-0).
- [137] K. Mei, J. Liu, X. Zhang, K. Cao, N. Rajatheva, and J. Wei, "A low complexity learning-based channel estimation for OFDM systems with online training," *IEEE Trans. Commun.*, vol. 69, no. 10, pp. 6722–6733, Oct. 2021, doi: [10.1109/TCOMM.2021.3095198](https://doi.org/10.1109/TCOMM.2021.3095198).
- [138] H. Mao, H. Lu, Y. Lu, and D. Zhu, "RoemNet: Robust meta learning based channel estimation in OFDM systems," in *Proc. IEEE Int. Conf. Commun. (ICC)*, Shanghai, China, May 2019, pp. 1–6, doi: [10.1109/ICC.2019.8761319](https://doi.org/10.1109/ICC.2019.8761319).
- [139] K. Mei, J. Liu, X. Zhang, N. Rajatheva, and J. Wei, "Performance analysis on machine learning-based channel estimation," *IEEE Trans. Commun.*, vol. 69, no. 8, pp. 5183–5193, Aug. 2021, doi: [10.1109/TCOMM.2021.3083597](https://doi.org/10.1109/TCOMM.2021.3083597).
- [140] J. Liu, K. Mei, X. Zhang, D. Ma, and J. Wei, "Online extreme learning machine-based channel estimation and equalization for OFDM systems," *IEEE Commun. Lett.*, vol. 23, no. 7, pp. 1276–1279, Jul. 2019, doi: [10.1109/LCOMM.2019.2916797](https://doi.org/10.1109/LCOMM.2019.2916797).
- [141] J. H. Fernandez, A. Omri, and R. D. Pietro, "Power grid surveillance: Topology change detection system using power line communications," *Int. J. Electr. Power Energy Syst.*, vol. 145, Feb. 2023, Art. no. 108634, doi: [10.1016/j.ijepes.2022.108634](https://doi.org/10.1016/j.ijepes.2022.108634).
- [142] C. Tang, Z. Chang, H. Liang, L. Zhang, and B. Pang, "Feature extraction method of HPLC communication signal based on genetic algorithm," *IET Commun.*, vol. 17, no. 13, pp. 1553–1561, Jun. 2023, doi: [10.1049/cmu2.12641](https://doi.org/10.1049/cmu2.12641).
- [143] E. Oyekanlu and J. Uddin, "Random forest-based ensemble machine learning data-optimization approach for smart grid impedance prediction in the powerline narrowband frequency band," in *Deterministic Artificial Intelligence*. IntechOpen, May 2020, doi: [10.5772/intechopen.91837](https://doi.org/10.5772/intechopen.91837).
- [144] J. Slacik, P. Mlynek, M. Ruzs, P. Musil, L. Benesl, and M. Ptacek, "Broadband power line communication for integration of energy sensors within a smart city ecosystem," *Sensors*, vol. 21, no. 10, p. 3402, May 2021, doi: [10.3390/s21103402](https://doi.org/10.3390/s21103402).
- [145] T. Mazhar, H. M. Irfan, I. Haq, I. Ullah, M. Ashraf, T. A. Shloul, Y. Y. Ghadi, Imran, and D. H. Elkamchouchi, "Analysis of challenges and solutions of IoT in smart grids using AI and machine learning techniques: A review," *Electronics*, vol. 12, no. 1, p. 242, Jan. 2023, doi: [10.3390/electronics12010242](https://doi.org/10.3390/electronics12010242).
- [146] F. Marcuzzi and A. M. Tonello, "Topology-based machine learning: Predicting power line communication quality in smart grids," *IEEE Access*, vol. 11, pp. 24851–24862, 2023, doi: [10.1109/ACCESS.2023.3245361](https://doi.org/10.1109/ACCESS.2023.3245361).
- [147] A. Dogan and D. C. Dogan, "A review on machine learning models in forecasting of virtual power plant uncertainties," *Arch. Comput. Methods Eng.*, vol. 30, no. 3, pp. 2081–2103, Nov. 2022, doi: [10.1007/s11831-022-09860-2](https://doi.org/10.1007/s11831-022-09860-2).
- [148] D. Shrestha, X. Mestre, and M. Payaró, "On channel estimation for power line communication systems in the presence of impulsive noise," *Comput. Electr. Eng.*, vol. 72, pp. 406–419, Nov. 2018, doi: [10.1016/j.compeleceng.2018.10.006](https://doi.org/10.1016/j.compeleceng.2018.10.006).
- [149] I. Shakeel, "Machine learning based featureless signalling," in *Proc. IEEE Mil. Commun. Conf. (MILCOM)*, Los Angeles, CA, USA, Oct. 2018, pp. 1–9, doi: [10.1109/MILCOM.2018.8599694](https://doi.org/10.1109/MILCOM.2018.8599694).
- [150] T. Ç. Akinci and A. A. Martinez-Morales, "Cognitive based electric power management system," *Balkan J. Electr. Comput. Eng.*, vol. 10, no. 1, pp. 85–90, Jan. 2022, doi: [10.17694/bajece.1060998](https://doi.org/10.17694/bajece.1060998).
- [151] H. Soy and İ. Toy, "Design and implementation of smart pressure sensor for automotive applications," *Measurement*, vol. 176, May 2021, Art. no. 109184, doi: [10.1016/j.measurement.2021.109184](https://doi.org/10.1016/j.measurement.2021.109184).
- [152] Y. M. Chung, "Performance comparisons of broadband power line communication technologies," *Appl. Sci.*, vol. 10, no. 9, p. 3306, May 2020, doi: [10.3390/app10093306](https://doi.org/10.3390/app10093306).
- [153] M. Leo, S. Sharma, and K. Maddulety, "Machine learning in banking risk management: A literature review," *Risks*, vol. 7, no. 1, p. 29, Mar. 2019, doi: [10.3390/risks7010029](https://doi.org/10.3390/risks7010029).
- [154] O. Ali, W. Abdelbaki, A. Shrestha, E. Elbasi, M. A. A. Alryalat, and Y. K. Dwivedi, "A systematic literature review of artificial intelligence in the healthcare sector: Benefits, challenges, methodologies, and functionalities," *J. Innov. Knowl.*, vol. 8, no. 1, Jan. 2023, Art. no. 100333, doi: [10.1016/j.jik.2023.100333](https://doi.org/10.1016/j.jik.2023.100333).
- [155] K. Liakos, P. Busato, D. Moshou, S. Pearson, and D. Bochtis, "Machine learning in agriculture: A review," *Sensors*, vol. 18, no. 8, p. 2674, Aug. 2018, doi: [10.3390/s18082674](https://doi.org/10.3390/s18082674).
- [156] Z. Peiling and Z. Hongxin, "Measurement and modeling of indoor low voltage power distribution line channel," in *Proc. 6th Asia-Pacific Conf. Environ. Electromagn. (CEEM)*, Shanghai, China, Nov. 2012, pp. 396–398, doi: [10.1109/CEEM.2012.6410652](https://doi.org/10.1109/CEEM.2012.6410652).
- [157] M. Z. Nisar, M. S. Ibrahim, M. Usman, and J.-A. Lee, "A lightweight deep learning model for automatic modulation classification using residual learning and squeeze–excitation blocks," *Appl. Sci.*, vol. 13, no. 8, p. 5145, Apr. 2023, doi: [10.3390/app13085145](https://doi.org/10.3390/app13085145).
- [158] M. Abadi et al., "TensorFlow: Large-scale machine learning on heterogeneous distributed systems," 2016, *arXiv:1603.04467*.
- [159] H. Asghari, R. E. Newman, and H. A. Latchman, "Bandwidth-efficient forward-error-correction-coding for high speed powerline communications," in *Proc. IEEE Int. Symp. Power Line Commun. Appl.*, Jan. 2006, pp. 355–360, doi: [10.1109/ISPLC.2006.247488](https://doi.org/10.1109/ISPLC.2006.247488).
- [160] Microcontrollers Lab. (Oct. 8, 2019). *Introduction to Power Line Communication*. Accessed: Jul. 2023. [Online]. Available: <https://microcontrollerslab.com/introduction-to-power-line-communication/>
- [161] A. O. Aderibole, E. K. Saathoff, K. J. Kircher, S. B. Leeb, and L. K. Norford, "Power line communication for low-bandwidth control and sensing," *IEEE Trans. Power Del.*, vol. 37, no. 3, pp. 2172–2181, Jun. 2022, doi: [10.1109/TPWRD.2021.3106585](https://doi.org/10.1109/TPWRD.2021.3106585).
- [162] G. López, J. Matanza, D. De La Vega, M. Castro, A. Arrinda, J. I. Moreno, and A. Sendin, "The role of power line communications in the smart grid revisited: Applications, challenges, and research initiatives," *IEEE Access*, vol. 7, pp. 117346–117368, 2019, doi: [10.1109/ACCESS.2019.2928391](https://doi.org/10.1109/ACCESS.2019.2928391).
- [163] L. Lampe, A. M. Tonello, and T. Swart, *Power Line Communications: Principles, Standards and Applications From Multimedia to Smart Grid*, 2nd ed. Hoboken, NJ, USA: Wiley, 2016, doi: [10.1002/9781118676684](https://doi.org/10.1002/9781118676684).
- [164] D. B. Unsal and T. Yalcinoz, "Applications of new power line communication model for smart grids," *Int. J. Comput. Electr. Eng.*, vol. 7, no. 3, pp. 168–178, 2015, doi: [10.17706/ijcee.2015.7.3.168-178](https://doi.org/10.17706/ijcee.2015.7.3.168-178).
- [165] W. Huang, T. Zhang, and X. Yao, "Optimization for sequential communication line attack in interdependent power-communication network," *Phys. A, Stat. Mech. Appl.*, vol. 592, Apr. 2022, Art. no. 126837, doi: [10.1016/j.physa.2021.126837](https://doi.org/10.1016/j.physa.2021.126837).
- [166] S. M. Hashim and I. B. Al-Mashhadani, "Adaptation of powerline communications-based smart metering deployments with IoT cloud platform," *Indonesian J. Electr. Eng. Comput. Sci.*, vol. 29, no. 2, p. 825, Feb. 2023, doi: [10.11591/ijecs.v29.i2.pp825-837](https://doi.org/10.11591/ijecs.v29.i2.pp825-837).
- [167] M. O. F. Goni, M. Nahiduzzaman, M. S. Anower, M. M. Rahman, M. R. Islam, M. Ahsan, J. Haider, and M. Shahjalal, "Fast and accurate fault detection and classification in transmission lines using extreme learning machine," *e-Prime, Adv. Electr. Eng., Electron. Energy*, vol. 3, Mar. 2023, Art. no. 100107, doi: [10.1016/j.prime.2023.100107](https://doi.org/10.1016/j.prime.2023.100107).
- [168] R. Ramesh, S. Gurugopinath, and S. Muhaidat, "Hybrid protocols for relay-assisted non-orthogonal multiple access in power line communications," *IEEE Open J. Commun. Soc.*, vol. 4, pp. 1813–1825, 2023, doi: [10.1109/OJCOMS.2023.3289185](https://doi.org/10.1109/OJCOMS.2023.3289185).

- [169] A. A. Oliveira, M. S. Buckeridge, and R. Hirata, "Detecting tree and wire entanglements with deep learning," *Trees*, vol. 37, no. 1, pp. 147–159, May 2022, doi: [10.1007/s00468-022-02305-0](https://doi.org/10.1007/s00468-022-02305-0).
- [170] I. Topaloglu, "Deep learning based a new approach for power quality disturbances classification in power transmission system," *J. Electr. Eng. Technol.*, vol. 18, no. 1, pp. 77–88, Jan. 2023, doi: [10.1007/s42835-022-01177-1](https://doi.org/10.1007/s42835-022-01177-1).



**TAHIR CETIN AKINCI** (Senior Member, IEEE) received the bachelor's degree in electrical engineering, in 2000, and the master's and Ph.D. degrees, in 2005 and 2010, respectively. From 2003 to 2010, he was a Research Assistant with Marmara University, Istanbul, Turkey. He is currently a Full Professor with the Electrical Engineering Department, Istanbul Technical University (ITU), in 2020. He was the Vice Dean with the Graduate School, from 2020 to 2021, and the Electrical and Electronic Engineering Faculty, from 2020 to 2021. He assumed the role of a Visiting Scholar with the University of California at Riverside (UCR). His current research interests include artificial neural networks, deep learning, machine learning, cognitive systems, signal processing, power systems, power line communication, and data analysis.



**GOKHAN ERDEMIR** (Senior Member, IEEE) received the B.Sc., M.Sc., and Ph.D. degrees from Marmara University, Turkey. He was a Research Scholar with the Robotics and Automation Laboratory, Michigan State University, East Lansing, MI, USA, and the Health Management and Research Center, University of Michigan, Ann Arbor, MI, USA. He is currently an Associate Professor with the Engineering Management and Technology Department, The University of Tennessee at Chattanooga (UTC). His current research interests include control theory, robotics, industrial automation, AGVs, and engineering education.



**A. TARIK ZENGİN** received the B.S. degree in electrical and electronics engineering from Ege University, Turkey, in 2007, and the M.E. and Ph.D. degrees from the Department of Computer Science and Electrical Engineering, Kumamoto University, Japan, in 2010 and 2013, respectively. Currently, he is an Assistant Professor with Istanbul Technical University. His current research interests include autonomous systems and control theory.



**SERHAT SEKER** received the degree from the Electrical Engineering Department, Istanbul Technical University (ITU), and the master's and Ph.D. degrees from the Electrical Engineering Division, Science and Technology Institute, ITU. He studied the Ph.D. thesis with the Energy Research Centre of the Netherlands (ECN) and worked on signal analysis techniques. He was an Assistant Professor and an Associate Professor with ITU, in 1995 and 1996. He worked in industrial signal processing with the Maintenance and Reliability Centre, The University of Tennessee, Knoxville, TN, USA, in 1997. He was the Vice Dean with the Electrical and Electronic Engineering Faculty, from 2001 to 2004, and the Department Head of the Electrical Engineering, from 2004 to 2007. He was also the Dean of the Faculty of Electrical and Electronics, from 2013 to 2020.



**ABDOULKADER IBRAHIM IDRİSS** received the Ph.D. degree in photonic engineering from Université de Franche-Comté, Besançon, France, with specialization in optical nano-antennas for the inspection of photonic structures. He was the Director of the Logistic and Transport Centre (Centre of Excellence), financed by the World Bank, from 2019 to December 2021. He is currently a Professor with the Department of Electrical Engineering. He is the Dean of the Faculty of Engineering. He is also an Assistant Professor with the Faculty of Engineering, Université de Djibouti, Djibouti. His current research interests include materials, photonic, and nanomaterials for renewable energy. He is a Guest Editor for the Special Issue Big Data in Renewable Energy of *Renewable and Sustainable Energy Reviews* (Elsevier).

• • •