

UC Irvine

SSOE Research Symposium Dean's Awards

Title

AVA by Dispensus

Permalink

<https://escholarship.org/uc/item/11q12701>

Authors

Cetrola, Claudia
Shivkumar, Sneha
Noel, Erik
et al.

Publication Date

2016-04-01

Peer reviewed

dispensus

Team: Sneha Shivkumar, Erik Noel, Claudia Cetrola, Katrina Henrikson, Sepehr Zomorodian **Mentors:** Craig Lauer & Samir Shreim

OVERVIEW

Taking medication is an integral part of many people's lives, yet medication as a concept is heavily stigmatized in society. Patients tend to shy away from taking medication in public in an effort to keep from appearing "sick" or "ill" and will oftentimes skip doses when they are outside the comfort of their home. Ava by Dispensus aims to eliminate the discomfort coupled with taking medication, with the ultimate goal of improving drug adherence, by creating a device that makes it convenient and inconspicuous to take medication publicly.

PRODUCT

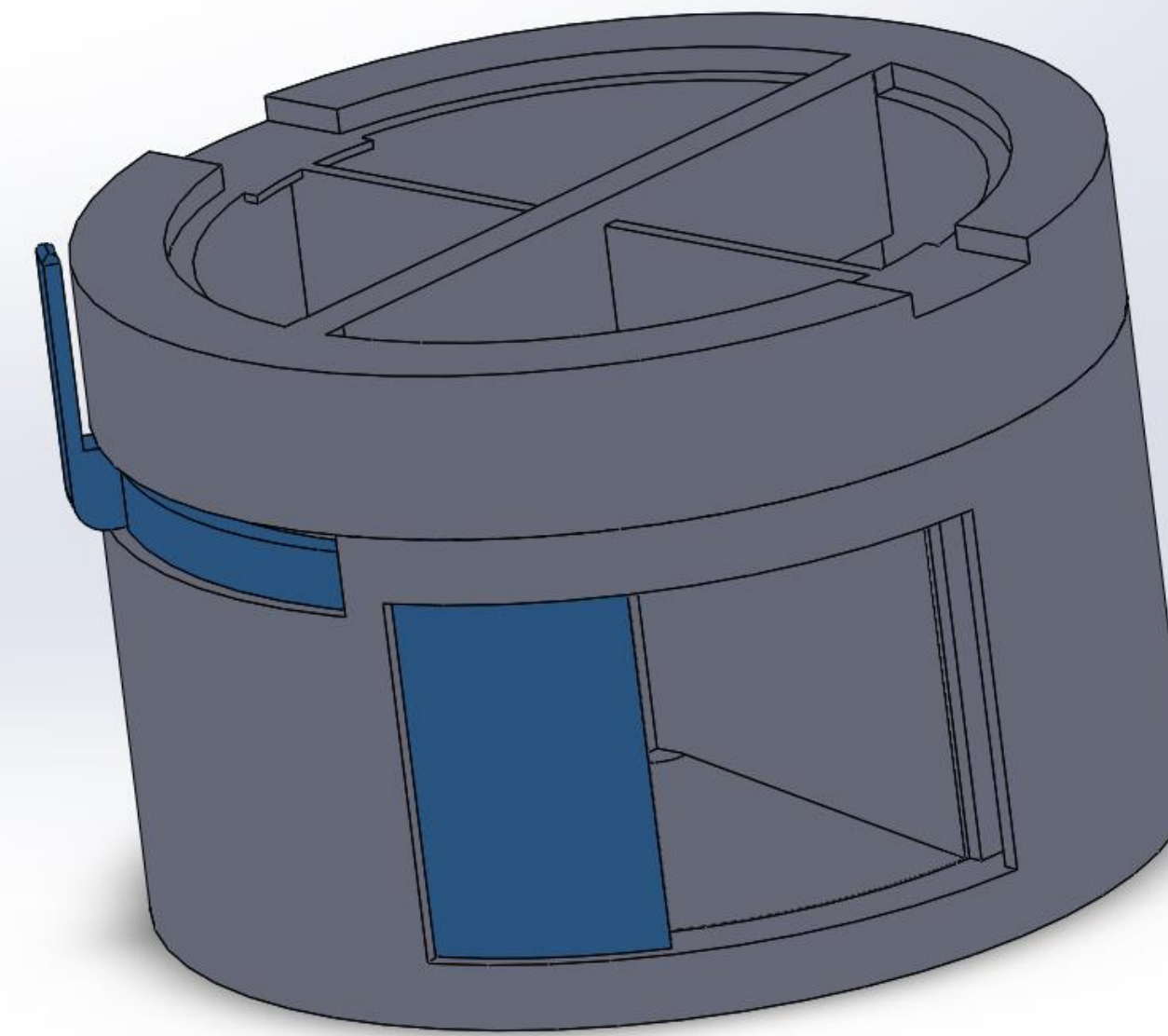

- Ava combines a strategically designed pill box and water bottle.
- The cap holds eight pills and allows users to store and administer medication in a private, efficient manner.
- Microcontroller and sensors built into the cap track drug adherence via Bluetooth communication with the user's phone.
- Phone correspondence enables scheduled reminders.
- Proximity sensing prevents medication from being left behind.

MARKET RESEARCH

Do You Have Reservations About Taking Medication in Public

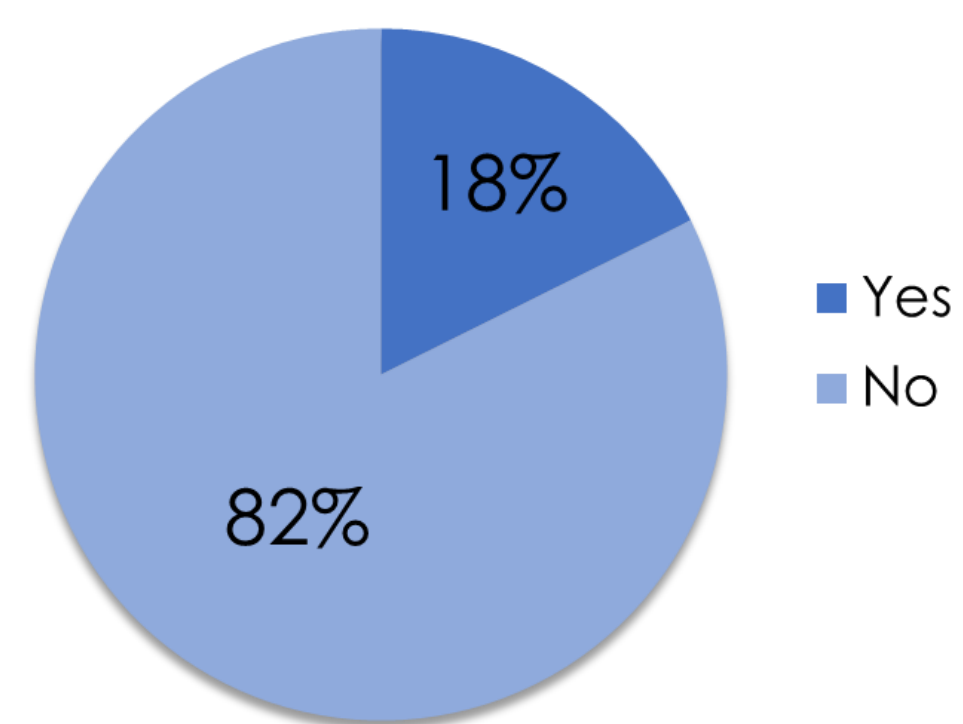

What Causes You to Miss Doses?

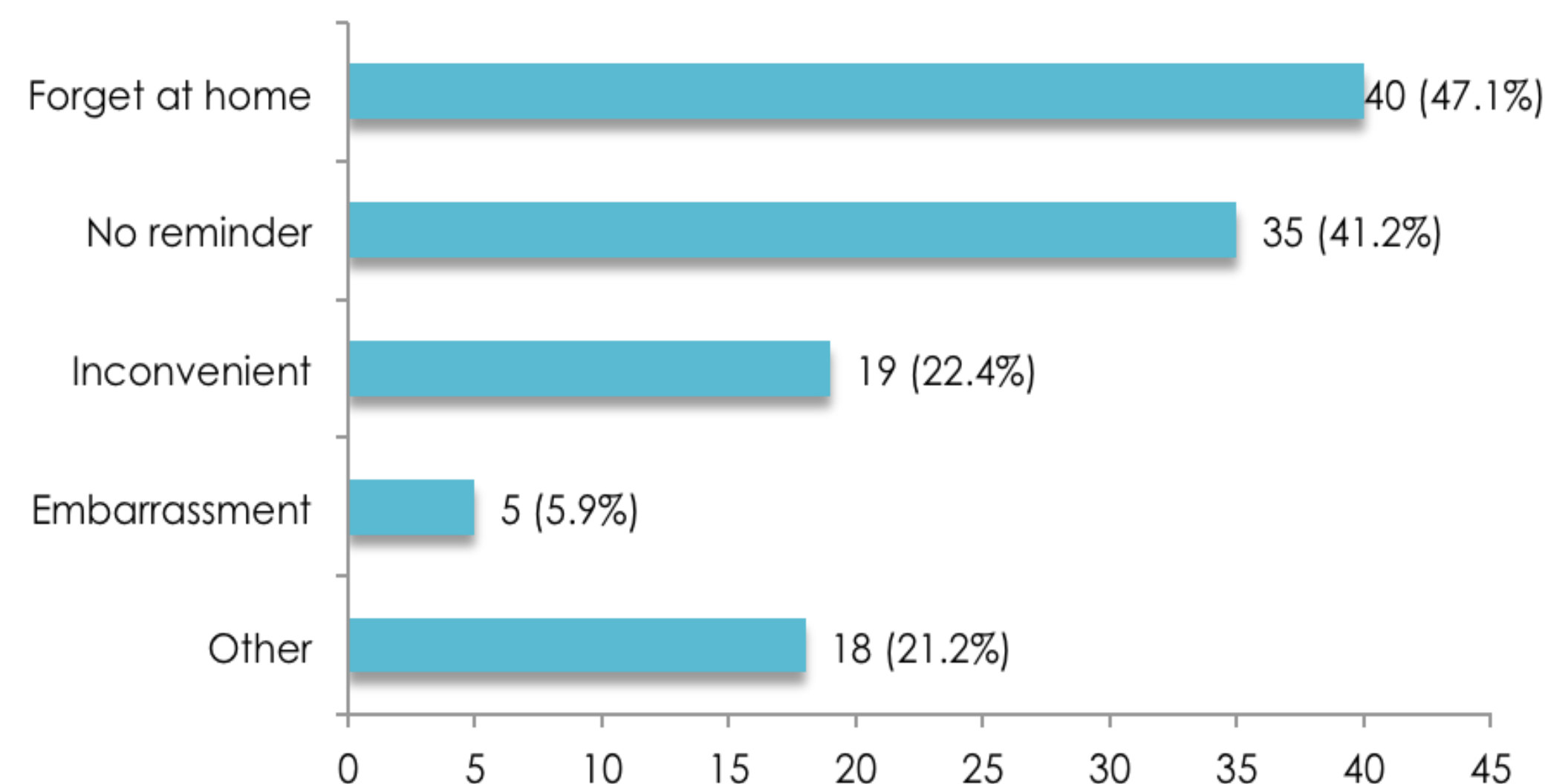

Why do you have reservations about taking medication in public?

"The stigma that something about your health is abnormal"

"Don't want people to know of your health issue"

"Fear of being ridiculed"

COMPETITIVE ADVANTAGE

Dispensus faces a competitive landscape comprised of simple water bottles to stand alone pill boxes that have the capability to communicate with the user's phone. Current market products fail to address the discomfort of public medication administration, as they lack privacy. Ava will eliminate the action of physically removing medication from the container, and substitutes it with the simultaneous administration of water and pill. Market research supports that a feature like this will greatly encourage people to take their medication outside the comfort of their home.

Product Name	Water Bottle	Reminder Notification	Inconspicuous	Feedback Mechanism
Dispensus	<input checked="" type="checkbox"/>	<input checked="" type="checkbox"/>	<input checked="" type="checkbox"/>	<input checked="" type="checkbox"/>
Nalgene	<input type="checkbox"/>	<input type="checkbox"/>	<input type="checkbox"/>	<input type="checkbox"/>
Asobu	<input type="checkbox"/>	<input type="checkbox"/>	<input type="checkbox"/>	<input type="checkbox"/>
PillPal	<input type="checkbox"/>	<input checked="" type="checkbox"/>	<input type="checkbox"/>	<input checked="" type="checkbox"/>