

Lawrence Berkeley National Laboratory

Recent Work

Title

ENERGY LEVELS OF PU239 POPULATED BY THE BETA DECAY OF NP239

Permalink

<https://escholarship.org/uc/item/1261z1wx>

Authors

Hollander, J.M.

Smith, W.G.

Mihelich, J.W.

Publication Date

1955-09-28

UNIVERSITY OF
CALIFORNIA

*Radiation
Laboratory*

TWO-WEEK LOAN COPY

*This is a Library Circulating Copy
which may be borrowed for two weeks.
For a personal retention copy, call
Tech. Info. Division, Ext. 5545*

BERKELEY, CALIFORNIA

DISCLAIMER

This document was prepared as an account of work sponsored by the United States Government. While this document is believed to contain correct information, neither the United States Government nor any agency thereof, nor the Regents of the University of California, nor any of their employees, makes any warranty, express or implied, or assumes any legal responsibility for the accuracy, completeness, or usefulness of any information, apparatus, product, or process disclosed, or represents that its use would not infringe privately owned rights. Reference herein to any specific commercial product, process, or service by its trade name, trademark, manufacturer, or otherwise, does not necessarily constitute or imply its endorsement, recommendation, or favoring by the United States Government or any agency thereof, or the Regents of the University of California. The views and opinions of authors expressed herein do not necessarily state or reflect those of the United States Government or any agency thereof or the Regents of the University of California.

UNIVERSITY OF CALIFORNIA

Radiation Laboratory
Berkeley, California

Contract No. W-7405-eng-48

ENERGY LEVELS OF Pu^{239} POPULATED BY THE
BETA DECAY OF Np^{239}

J. M. Hollander, W. G. Smith, and J. W. Mihelich

September 28, 1955

ENERGY LEVELS OF Pu²³⁹ POPULATED BY THE BETA DECAY OF Np²³⁹

J. M. Hollander, W. G. Smith, and J. W. Mihelich*
Radiation Laboratory and Department of Chemistry
University of California, Berkeley, California

September 28, 1955

ABSTRACT

The conversion electron spectrum arising from the beta decay of 2.3-day Np²³⁹ has been studied with three 180° permanent magnet photographic spectrographs. The following transitions, with multipolarities where known, were observed (energy in kev): 44.64 (M1 + E2), 49.40 (M1 + E2), 57.25 (E2), 61.4 (E1), 67.82 (E2), 106.1 (E1), 106.4, 181.8, 209.9 (M1), 226.4, 228.4 (M1), 254.6, 273.1, 277.7 (M1), 285.6, 316.1, and 334.5. Gamma-gamma coincidence experiments have also been performed. It is necessary in order to account for the present data to modify the previously accepted level scheme for Pu²³⁹; a revised scheme is presented, with spin and relative parity assignments. The energy and intensity data are discussed in terms of the Bohr-Mottelson unified nuclear model.

A rough measurement of the Auger coefficient in Z = 94 is reported, and also an experimental value for the K-electron binding energy in plutonium is given.

*On leave from the University of Notre Dame, Notre Dame, Indiana.

ENERGY LEVELS OF Pu²³⁹ POPULATED BY THE BETA DECAY OF Np²³⁹

J. M. Hollander, W. G. Smith, and J. W. Mihelich
Radiation Laboratory and Department of Chemistry
University of California, Berkeley, California

September 28, 1955

I. INTRODUCTION

Excited states of the Pu²³⁹ nucleus may be populated by three radioactive decay processes: beta decay of Np²³⁹, alpha decay of Cm²⁴³, and electron capture of Am²³⁹.

The beta decay of 2.3-day Np²³⁹ has been studied by several groups.¹⁻⁴ Although the results of these researches have been reported only briefly in the literature, it seems reasonably certain that there are four or five beta groups leading to levels in Pu²³⁹. In addition, Graham and Bell² have reported the existence of a metastable level with a half-life of 1.1×10^{-9} seconds. More recently, Engelkemeir and Magnusson⁵ have published their results on a metastable level of 0.19-microsecond half-life. In addition, there are a large number of gamma-ray transitions.⁶

The alpha decay of Cm²⁴³ has been investigated by Asaro, Thompson, and Perlman⁷ who employed a magnetic alpha spectrometer and alpha-gamma coincidence techniques. The results of their experiments also define several of the Pu²³⁹ levels.

There are at present few spectroscopic data on the electron-capture decay of Am²³⁹.

The level scheme of Pu²³⁹ would appear to present an interesting case for interpretation within the framework of the Bohr-Mottelson unified nuclear model. The ground-state spin of 1/2 for Pu²³⁹ (measured

by Bleaney et al.⁸⁾ suggests that in this case the spacings between rotational levels may be "anomalous."⁹ Such anomalous bands have not yet been identified among the odd-mass isotopes of the heavy ($Z > 92$) elements.

The existence of two levels with measured half-lives, and the advancement of the theory to the point where one can predict transition probabilities (the K selection rules, etc.) make the determination of multipole orders, the assignment of level spins and parities, and the determination of gamma ray transition intensities both interesting and vital.

II. EXPERIMENTAL PROCEDURE

The Np²³⁹ samples were prepared by irradiation of approximately one-gram amounts of U²³⁸ for eight hours in the Livermore reactor.

Three flat 180° permanent magnet spectrographs, which photographically record all the electron lines simultaneously, were used in this work. These spectrographs have moderately high resolution, a feature which was important because of the large number of electron lines per energy interval. The spectrographs have fields of approximately 53, 99 and 215 gauss, and have been described previously by Smith and Hollander.¹⁰ Calibration of the spectrographs consisted in the determination of the effective magnetic fields at various ρ values using conversion electron lines of gamma transitions whose energies have been accurately determined. Conversion lines of I¹³¹ and Am²⁴¹ were used in the calibration.^{11,12} A resolution $\Delta\rho/\rho$ of 0.13 percent has been obtained in the 53-gauss spectrograph and 0.17 percent in the 99-gauss spectrograph.

Eastman No-Screen x-ray film on $3/4 \times 15 \times 0.040$ in. glass backing was used to record the electron lines; the determination of the relative intensities of these lines has been done by a densitometer method described previously.¹⁰

The following procedure for neptunium purification was suggested by W. M. Gibson. The uranium target material was dissolved in concentrated hydrochloric acid with the addition of a minimum amount of concentrated nitric acid; zirconium, barium, strontium, and cadmium carriers were added. Neptunium was reduced to the tetrapositive state by the addition of ferrous ion. Phosphoric acid was added to precipitate zirconium phosphate, which carried the neptunium. The precipitate was dissolved in 1 M HNO_3 plus 4 M HF, and lanthanum fluoride was precipitated carrying the neptunium. The lanthanum fluoride was dissolved in boric acid plus nitric acid, and lanthanum hydroxide was precipitated with ammonia. The lanthanum hydroxide was dissolved in concentrated hydrochloric acid; 1 M NH_2OH , SnCl_2 , and 5 M KI were added, and the solution was heated in a water bath to ensure that the neptunium was in the tetrapositive state. The hydrogen-ion concentration was adjusted to 1 M, and the neptunium was extracted into thenoyltrifluoroacetone (TTA) for ten minutes. The neptunium was then back-extracted into 8 M HNO_3 .

The nitric-acid solution was evaporated to dryness, and the neptunium activity was dissolved in 0.5 ml of ammonium-oxalate solution (40 g/L) which had been made slightly acidic with nitric acid. The solution was placed in a platinum electrolysis cell which utilized a 10-mil platinum wire as the cathode upon which the neptunium was electrodeposited.¹⁰ The active wires were mounted in a source holder whose position in the camera could be adjusted and reproduced within several mils.

As a check on the radiochemical purity of the source, the decay of one of the purified neptunium fractions was followed for ten half-lives in a Geiger-Müller counter with no evidence of the presence of any activity except Np^{239} . The observed half-life was 2.3 days, in good agreement with previous measurements.⁶

III. EXPERIMENTAL RESULTS

A reproduction of one of the spectrograms is shown in Fig. 1. The electron data are summarized in Table I, which presents the measured electron line energies, their shell or subshell assignments, and their relative intensities as measured with the densitometer. (The absence of an intensity figure indicates that the line was too weak for quantitative measurement.) It is seen that the internal consistency of the transition energies (electron kinetic energy plus atomic binding energy¹³) is of the order of 0.1 percent; the absolute error is estimated to be < 0.3 percent. One is able to set up a series of energy sums of these transitions, given in Table II, which imply two partial level schemes, one being the inversion of the other. The coincidence data of Graham and Bell² and the coincidence and alpha particle data of Asaro, Thompson, and Perlman⁷ make one choice unique, in showing that the three intense transitions (210, 228, 278 keV) originate from a common level. This partial level scheme is shown in Fig. 2.

The 61- and 106-keV transitions have previously been assigned as E1 transitions on the basis of their total L shell conversion coefficients.⁵ From our present data on the L and M subshell conversion ratios it is

possible to assign the multipolarities and multipole mixing ratios (or limits) of the other strong transitions. From these data and the theoretical conversion coefficients of Rose¹⁴ one can then compute the total transition intensities. This information is summarized in Table III.

Table I
Conversion Electron Data for Np²³⁹

Electron Energy (kev)	Shell	Transition Energy (kev)	Visual Intensity Estimate†	Intensity (densitometer)	Remarks
21.56	L _I	44.66	m	100	--
22.40	L _{II}	44.65	w-m	50	--
26.58	L _{III}	44.64	w-m	50	--
38.70	M _I	44.63	w	--	--
	M _{II}	--	--	--	M _{II} line masked by 57.3 L _{III} line.
40.07	M _{III}	44.63	w	--	--
43.09	N _I	44.65	w	--	--
44.32	0	44.6	vw	--	E _γ = 44.64 kev.
26.28	L _I	49.38	m	100	--
27.13	L _{II}	49.38	s	120	--
31.34	L _{III}	49.40	s	120	--
43.46	M _I	49.39	m	--	--
43.85	M _{II}	49.41	m	--	--
44.82	M _{III}	49.38	m	--	--
47.80	N _I	49.36	w	--	--
48.08	N _{II}	49.36	w	--	--
48.29	N _{III}	49.42	w	--	--
49.11	0	49.4	vw	--	E _γ = 49.40 kev.

Table I (Continued)

Electron Energy (kev)	Shell	Transition Energy (kev)	Visual Intensity Estimate†	Intensity (densitometer)	Remarks
34.13	L _I	57.23	w	< 25	--
35.01	L _{II}	57.26	vvs	460	--
39.20	L _{III}	57.26	vvs	360	--
51.32	M _I	57.25	vvw	--	--
51.74	M _{II}	57.30	vs	180	--
52.71	M _{III}	57.27	vs	165	--
55.84	N _{II}	57.22	s	--	--
56.10	N _{III}	57.23	s	--	--
56.37	N _{IV(?)}	57.23	vvw(?)	--	--
56.98	O	57.3	m-s	--	--
57.22	P	~57.3	vvw	--	E _γ = 57.25 kev
38.32	L _I	61.42	vw	~10	Other L lines masked. E _γ = 61.4 kev
45.58	L _{II}	67.83	vs	275	--
49.81	L _{III}	67.87	vs	240	--
62.25	M _{II}	67.81	vs	115	--
63.25	M _{III}	67.81	vs	115	--
63.94	M _{IV}	67.92	vvw	--	--
66.41	N _{II}	67.79	m-s	--	--
66.70	N _{III}	67.83	m-s	--	--
67.57	O	67.9	m	--	E _γ = 67.82 kev

Table I (Continued)

Electron Energy (kev)	Shell	Transition Energy (kev)	Visual Intensity Estimate†	Intensity (densitometer)	Remarks
83.02	L _I	106.12	vs	140	--
83.87	L _{II}	106.12	vs	150	--
88.05	L _{III}	106.11	(m)	(~90)	Composite with 210.0 K line.
100.23	M _I	106.16	m	--	--
100.55	M _{II}	106.11	m	--	--
101.56	M _{III}	106.12	w	--	E _γ = 106.12 kev
84.18	L _{II}	106.43	vw	--	--
88.39	L _{III}	106.45	vvw	--	E _γ = 106.4 kev
102.2	L _I (?)	125.3	vvvw	--	Extremely weak line. E _γ = 125.3 kev (?)
59.86	K	181.7	w-m	--	L _{II} , L _{III} lines not seen.
158.8	L _I	181.9	w	--	E _γ = 181.8 kev
88.08	K	209.9	vvs	540	--
186.8	L _I	209.9	s	100	--
187.7	L _{II}	209.9	w	--	--
204.1	M _I	210.0	w	--	--
208.6	N _I	210.1	vw	--	E _γ = 209.9 kev
104.6	K	226.4	m-s	--	L _I line not seen. L _{II} and L _{III} lines would be masked. E _γ = 226.4 kev.

Table I (Continued)

Electron Energy (kev)	Shell	Transition Energy (kev)	Visual Intensity Estimate†	Intensity (densitometer)	Remarks
106.6	K	228.4	vvs	1520	--
205.3	L _I	228.4	s	325	--
206.1	L _{II}	228.4	m	--	--
222.3	M _I	228.2	m-s	--	--
222.9	M _{II}	228.4	vvw	--	--
226.8	N _I	228.4	w-m	--	--
228.1	O	228.4	vw	--	$E_{\gamma} = 228.4$ kev
132.8	K	254.6	w	--	--
231.2	L _I	254.3	vvvw	--	$E_{\gamma} = 254.6$ kev
151.3	K	273.1	vw	--	$E_{\gamma} = 273.1$ kev
156.1	K	277.9	vs	1080	--
254.5	L _I	277.6	s	190	--
255.5	L _{II}	277.8	w	--	--
259.6	L _{III}	277.7	w	--	--
271.6	M _I	277.5	m	--	--
275.8	N _I	277.4	w	--	--
277.2	O	277.5	vw	--	$E_{\gamma} = 277.7$ kev
163.8	K	285.6	vw	--	--
263.4	L _{II}	285.7	--	--	L _I line probably absent.
267.4	L _{III}	285.5	--	--	$E_{\gamma} = 285.6$ kev.

Table I (Continued)

Electron Energy (kev)	Shell	Transition Energy (kev)	Visual Intensity Estimate†	Intensity (densitometer)	Remarks
194.3	K	316.1	vvw	--	$E_{\gamma} = 316.1$ kev
212.7	K	334.5	vvw	--	--
310.9	L _I	334.0	--	--	--
312.1	L _{II}	334.4	--	--	$E_{\gamma} = 334.5$ kev
97.09	L _I	120.2	vvvw	--	Extremely weak line; could also be K-L _I -N _I Auger line.

Auger Lines

$E_{\text{experimental}}$	Vacancies	$E_{\text{theoretical}}^*$	Visual Intensity Estimate
75.19	K-L _I -L _I	75.2	w-m
76.07	K-L _I -L _{II}	76.0	m
80.29	K-L _I -L _{III}	80.2	vw
81.08	K-L _{III} -L _{II}	81.0	w
85.29	K-L _{III} -L _{III}	85.3	vvw
92.84	K-L _I -M _I	92.8	vvw
97.09	K-L _I -N _I	97.1	vvvw
109.9	K-M _I -M _I	110.0	vvvw

† w - weak
 m - moderate
 s - strong
 v - very

*I. Bergström and R. D. Hill, Arkiv Fysik 8, 2, 21 (1954).

Table II

Energy Sums of Transitions Following Beta Decay of Np^{239}

(a)	$49.4 + 228.4 = 277.8$
	$67.8 + 210.0 = 277.8$
	crossover = 277.7
(b)	$49.4 + 273.0 = 322.4$
	$67.8 + 254.6 = 322.4$
	$277.8 + 44.6 = 322.4$
(c)	$277.8 + 44.6 + 61.4 = 383.8$
	$277.8 + 106.1 = 383.9$
	$67.8 + 316.1 = 383.9$
	$49.4 + 334.5 = 383.9$
(d)	$277.8 + 226.4 = 504.2$
	$277.8 + 44.6 + 181.8 = 504.2$
(e)	$57.25 + 228.4 = 285.7$
	crossover = 285.6

Table III
Transition Data

Transition Energy (kev)	Total Electron Intensity ^a (relative)	Multipole Order ^b	Conversion Coefficient ^c	Transition Intensity $N_e + N_{\psi}$
44.64	~300	M1 (80%) + E2 (20%)	large ($\beta_L = 75$)	~300
49.40	475	M1 (70%) + E2 (30%)	large ($\beta_L = 55$)	475
57.25	1275	E2 (M1 < 5%)	large ($\alpha_L = 190$)	1275
61.4	~ 10(L _I)	E1	$\epsilon_{L_I} \sim 0.04^d$	~350
67.82	800	E2 (predominantly)	large ($\alpha_L = 85$)	800
106.1	500	E1	$\epsilon_L = 0.23^e$	2300
209.9	700 ^f	M1 (E2 < 30%)	($\beta_{\Sigma} = 5.0$)	840
228.4	1980	M1 (E2 < 20%)	($\beta_{\Sigma} = 3.8$)	2420
277.8	1400 ^f	M1 (E2 < 10%)	($\beta_{\Sigma} = 2.2$)	2000

a. We have taken $L/M + N \approx 3$.

b. Multipole orders and mixing ratios have been obtained from L subshell internal conversion data.

c. All conversion coefficients in parentheses are the theoretical values of Rose.¹⁴

d. Experimental value obtained using our observed ratio of $e_{L_I}(61)/e_K(\text{total}) = 0.003$ and the value $\alpha(61)/K \text{ x-ray}(\text{total})$ of 0.08 determined by Day, as reported by Engelkemeir and Magnusson.⁵

e. Experimental values of Engelkemeir and Magnusson.⁵

f. We have taken $K_{210}/K_{228}/K_{277} = 1.0/2.8/2.0$.

It should be pointed out that there is considerable uncertainty in the intensity values for electron lines of energy < 40 kev. However, the intensity ratio of any three L lines of a given transition should be fairly accurate. Since the emulsions employed are not yet fully calibrated, we also feel that the intensity ratio we obtain directly for the three high-energy transitions (210, 228, 278 kev) may not be reliable. But by combining the data of Slatis,¹ Schooley,¹⁵ and our ratios for electron lines close together in energy, we are able to arrive at K line intensities for these transitions which are probably reliable.

The level scheme of Fig. 2 can account for all the strong transitions observed in the decay of Np^{239} except the very intense 57.3 kev gamma ray. It had previously been assumed that this gamma ray fed the (x+) 278-kev level in parallel with the 44.6 kev gamma; however, in their study of the alpha decay of Cm^{243} , Asaro et al.⁷ have seen no indication from alpha particle energy differences of a level at (x+) 333 kev. But because of the wide variation of inherent alpha-decay rates in odd-A nuclei this fact in itself was not considered sufficient evidence that such a level does not exist. In the present study of Np^{239} several pieces of evidence, both experimental and theoretical, have been obtained which strongly suggest that the 57.3-kev gamma ray does not originate at a 333-kev level but that it is due to a direct transition from a 57.3-kev level to the ground state of Pu^{239} . This evidence can be summarized as:

1. Experimental. It is necessary in order to obtain an incoming-outgoing intensity balance at the level fed by the 228.4-kev gamma ray to postulate either that our intensity figures are wrong by a factor of five, or alternately that another transition several times the intensity of the 49.4-kev transition de-excites this level in parallel with the

49.4-keV gamma ray. Since we feel that our intensity measurements are reliable to better than a factor of two, the second alternative is preferred, and especially so since the 57.3-keV transition has enough intensity within the experimental error to effect such a balance. This new interpretation thus defines the first excited state of Pu^{239} to be 7.85 keV above the ground state and raises the energy of each of the previously known levels by that amount. Also, a weak gamma ray of 285.6 keV can now be assigned as the crossover from the $(277.8 + 7.9 =)$ 285.7 keV level, in competition with the 210.0-, 228.4-, and 277.7-keV gamma rays.*

2. Theoretical. With the level sequence 0, 7.85, 57.25, and 75.67 keV it is possible to obtain very good agreement with the energy ratios predicted by the Bohr-Mottelson formula for an "anomalous" $K = 1/2$ rotational band with ground-state spin $I = 1/2$. One cannot obtain agreement using the previous level sequence 0, 49.4, 67.8 keV. The interpretation of the present results in terms of the unified nuclear model will be discussed further in a later section.

Two weak gamma rays of energies 181.8 and 226.4 are seen whose energy difference, 44.6 keV, suggests that the 181.8 and 44.6 keV gamma rays are in coincidence and that the 226.4-keV ray is the crossover. Since the energy difference alone does not indicate the order of emission of the two gamma rays, the level so established could be located either at 512.1 keV or by inversion at 103.9 keV. In order to choose between these alternatives, D. Strominger has kindly examined the gamma-gamma coincidence spectrum of Np^{239} with a 50-channel scintillation coincidence spectrometer.¹⁷

* We have recently learned that a similar conclusion about the first excited state of Pu^{239} has been reached by J. O. Newton on the basis of Coulomb excitation experiments.¹⁶

The two sodium-iodide crystals were placed at 180° with respect to each other; 1.4 g/cm^2 of cadmium absorber were used on the single-channel side, and 0.7 g/cm^2 of cadmium absorber was used on the 50-channel detector. The chance rate was ~ 10 percent of the true coincidence rate. The coincidence curves are shown in Fig. 3. This experiment established that the 278-keV gamma ray is in coincidence with a gamma of ~ 230 keV. Also, with the gate set to accept ~ 230 -keV radiation, the coincidence spectrum showed peaks at ~ 230 and ~ 275 keV in the ratio of about two to one, which is the ratio expected if the 226-keV gamma originates at a 512-keV level and feeds the 286-keV level. The energies of the gammas which were observed to be in coincidence rule out the possibility that any of these are backscattered radiations. The existence of the 512-keV level thus seems well established. The amount of population of the 512-keV level relative to that of the 392-keV level was also determined from the ratio of 106-keV gammas to 226-keV gammas in the (278-keV gate) coincidence spectrum. The intensity of K x-rays (~ 100 keV) from the internal conversion of the 181.8- and 226.4-keV gammas is negligible compared to the intensity of the 106-keV gamma. The experimental ratio ($106\gamma/226\gamma$) was found to be ~ 40 , which when corrected for internal conversion, yields a population ratio (512-keV level/392-keV level) of ~ 0.1 .

The data presented above define seven excited states of Pu^{239} and allow the placement of sixteen transitions between these levels with an energy consistency of about 0.1 percent. The only gamma ray not included in the scheme is the weak 106.4-keV transition.

The level scheme which we feel best fits the present experimental data is presented in Fig. 4. The assignment of spins, parities, and the K-quantum numbers is discussed in the following sections.

IV. SPINS AND PARITIES

The ground state (A) of Pu²³⁹ has a spin 1/2. The level at 57.3 keV (C) depopulates directly to the ground state by a transition which is predominantly E2. By ordinary selection rules, the fact that M1 radiation is not observed would indicate $\Delta I = 2$ and hence the spin of level C would be 5/2. However, if other selection rules are operating to prohibit or greatly hinder M1 radiation then a spin of 3/2 is not impossible for level C. (One could not, however, invoke the K-selection rules to explain the prohibition of M1 radiation in a transition from a state $I = 3/2$ to a state $I = 1/2$, since K forbiddenness requires $\Delta K > L$ where L is the multipole order, and in this case the maximum possible ΔK is unity.) On the basis of present knowledge we prefer spin 5/2 (same parity as A) for level C.

The spin selection rules allow assignments of 3/2, 5/2, or 7/2 for level B because of the fact that transition CB is an M1 + E2 mixture. The spin of level D remains similarly undefined because one has multipolarity information only about transition DB.

Although one cannot obtain unique spin assignments of levels B and D on the basis of multipolarity information alone, it is tempting to postulate that states A, B, C, and D constitute a rotational band with the fundamental level at the ground state. Since the ground state spin is 1/2, the spins of B, C, and D would be 3/2, 5/2, and 7/2, respectively (same parity as ground state). One can then check the experimental data with the theoretical predictions of the Bohr-Mottelson formulation⁹ to see if a consistent picture is obtained.

The rotational energy levels for an "anomalous" $I = 1/2$ band are given by the equation:

$$E_i = \frac{\hbar^2}{2\mathcal{J}} [I(I+1) - 3/4 + a(-)^{I+1/2}(I+1/2)]$$

where \mathcal{J} = moment of inertia and I = spin of rotational level.

Using the values 7.85 and 57.25 kev, respectively, for the energies of the $3/2$ and $5/2$ levels, one obtains:

$$\begin{aligned} \frac{\hbar^2}{2\mathcal{J}} &= 6.25 \text{ kev} \\ a &= -0.58 \end{aligned}$$

Using these values for the coefficients one predicts an energy for the $I = 7/2$ level of 75.6 kev in excellent agreement with the experimental value 75.7 kev. It is interesting to note also that the value 6.25 kev for the splitting constant $\hbar^2/2\mathcal{J}$ is very similar to the value 6.20 kev found¹⁸ for the $K = 5/2$ band in Np^{237} , but is somewhat smaller than the value 7.37 kev found for the $K = 0$ band in Pu^{238} .¹⁰ This is in accord with the expectation that this quantity for odd- A nuclei should be less than for neighboring even-even nuclei.⁹

This value of $\hbar^2/2\mathcal{J}$ gives an additional measure of confidence in the interpretation of these levels in Pu^{239} as a $K = 1/2$ rotational band. If one makes a similar calculation using the previously accepted level scheme one finds $\hbar^2/2\mathcal{J} = 10.1$ kev which is decidedly high; further, one would predict from such an energy sequence that the $7/2$ level would lie at 183 kev; such a level has not been found.

Level E at 286 kev decays to levels B, C, and D by three gamma ray transitions which are predominantly (if not entirely) $M1$. If one assumes the correctness of the above spin assignments then the spin of state E is unambiguously $5/2$ (same parity). A gamma-gamma angular correlation

measurement on $\gamma(106)$ and $\gamma(278)$ would yield valuable data regarding the spin of level E.

The most intense transition leading from level F at 330 keV is FE (44.64 keV), which is an M1 + E2 mixture. In the absence of multipole order data for transitions FD (254.6 keV) and FC (273.0 keV), however, the configuration of level F cannot be specified further than $3/2$, $5/2$, or $7/2$ (same parity). Ordinarily, one might eliminate the choice of $3/2$ because of the absence of transition FD, but it is probably best not to over-extend such arguments. The spacing between levels E and F is about correct for a normal $K = 5/2$ rotational band with spins $5/2$, $7/2$, etc., and corresponds to a value 6.38 keV for the splitting constant, which is reasonably close to that found for the ground state band. We thus favor $I = 7/2$ for level F.

Transitions GF and GE have been assigned as electric dipoles on the basis of their experimental L conversion coefficients (see Table III). Thus level G must have spin $5/2$ or $7/2$ (opposite parity). This level is populated directly in about 50 percent of the Np^{239} beta disintegrations; if one accepts the measured¹⁹ spin of $1/2$ for Np^{239} , then level G in Pu^{239} cannot have so high a spin as $7/2$, and must be $5/2$. However, a serious discrepancy between the present data and the value $1/2$ for the spin of Np^{239} seems unavoidable; the fact that the parity of level G is different from that of level E means that beta decay to one or the other of these levels would be second forbidden; whereas, in fact, both beta branches proceed with log ft values in the range 6.5 - 7.0 and account for ~90 percent of the Np^{239} disintegrations. These difficulties would be removed if the spin of Np^{239} were $3/2$ or $5/2$, in which case the spin of level G in Pu^{239} could be either $5/2$ or $7/2$ (opposite parity from ground state).

It is also interesting to note the slowness of beta decay to the levels of the ground state rotational band. Using a figure of ~ 5 percent beta branching to the low lying states¹⁻⁴ one calculates a log ft of ~ 9 which is significant because states with such a wide range of spin values ($I = 1/2$ to $I = 7/2$) are available as final states in beta decay. Only if the spin of Np^{239} were $5/2$ could one explain the slowness of beta decay to the $K = 1/2$ band on the basis of the K selection rule which would allow only beta decays with $\Delta I \geq 2$.

Level H decays by two transitions which are probably dipoles, hence this state may have spin $5/2$ or $7/2$.

It should be emphasized that the above assignments of spins and parities are consistent with the multipolarity data but are by no means experimentally proved. The level scheme is based to a considerable extent on the fact that the lowest four levels seem to have the properties expected of a Bohr-Mottelson $K = I = 1/2$ rotational band.⁹

Finally, an obvious but crucial test of this decay scheme would be the search for strong M and N conversion lines of the 7.9-keV transition, which should take place in ~ 75 percent of the disintegrations.

V. GAMMA-RAY TRANSITION PROBABILITIES

The unified model, which describes the features of rotational states in strongly deformed nuclei, also implies definite and simple rules governing the relative strengths of gamma transitions within a rotational band or those from a given nuclear state to the various members of a rotational band. These rules are presented by Alaga, Alder, Bohr, and Mottelson.²⁰ In addition to the usual total angular momentum (I) and

parity (π) quantum numbers, each state is characterized by the projection value of I on the axis of nuclear symmetry; this new quantum number is called K , and is equal to or less than I . The extent to which K is a "good" quantum number will depend, in each instance, upon the degree of validity of the approximations made in the theoretical derivation, for example, the assumption that the rotational motion can be treated independently of the intrinsic motion. Since these approximations are expected to be most nearly valid in this region of large nuclear deformations, it is of interest to compare the experimental observations concerning the gamma ray transition rates in Pu²³⁹ with those predicted theoretically.

Rasmussen et al.²¹ in their study of the energy levels of the neighboring even-even nucleus Pu²³⁸ have found that the K selection rules are able to account for several observations which find no explanation by ordinary ΔI selection rules, for example, the absence of $M1$ radiation in a transition between states where $\Delta I = 0$, no. (In that instance, $\Delta K = 2$, and the selection rule $\Delta K \leq L$ therefore forbids $M1$ radiation, while $E2$ radiation is allowed.)

There are several places where the present data on Pu²³⁹ allow a comparison between theory and experiment. First, one can examine the transition rates within the ground state rotational band, which has $K = 1/2$. The intensity rules as given by Alaga et al.²⁰ for the reduced transition probability ratio for the emission of a given multipole radiation from a state i to different members, f , f' , of a rotational band are:

$$\frac{B(L, I_i \rightarrow I_f)}{B(L, I_i \rightarrow I_{f'})} = \frac{[I_i L K_i (K_f - K_i) | I_i L I_f K_f]^2}{[I_i L K_i (K_f - K_i) | I_i L I_{f'} K_{f'}]^2}$$

where $[I_i L K_i (K_f - K_i) | I_i L I_f K_f]$ is the vector addition coefficient for the

addition of the angular momenta I_i and L to form the resultant I_f . These coefficients have been tabulated by Simon.²² These rules predict that the E2 components of the 57.3- and 49.4-keV gamma rays from the 5/2 state to the 3/2 and 1/2 states, respectively, should compete with each other in the ratio 3.5. The experimental ratio of reduced gamma transition probabilities, obtained from the data of Table III by correction for conversion coefficients and by the removal of the fifth power energy dependence, is $3.2 \pm \sim 1.0$. The rules also predict that the ratio of intrinsic E2 gamma transition probabilities from the 7/2 state to the 3/2 and 5/2 states, respectively, should be ~ 10 . Correcting for the energy dependence, the observed ratio should be ~ 1000 . Although we do not know what to expect for the M1 transition rate between the 7/2 and 5/2 states, it is perhaps not surprising that we have not observed this transition (18.4 keV) while the 67.8-keV transition between the 7/2 and 3/2 states is quite strong.

One has next the very interesting level at 286 keV, which we have postulated (on the basis of multipolarity and energy data) to be the base state of a $K = 5/2$ rotational band. This level has a measured lifetime of 1.1×10^{-9} seconds.² If one calculates the partial gamma-ray lifetimes of the 210- and 278-keV M1 transitions which partially depopulate this level one finds that they are quite slow; in fact, the ratio of observed lifetime to that calculated from the Weisskopf single-proton formula is about 10^4 in each case. This hindrance of M1 radiation finds a natural explanation from the fact that transitions between the upper ($K = 5/2$) and lower ($K = 1/2$) bands involve a ΔK of two. Since the K selection rule demands that $\Delta K \leq L$, M1 transitions between these two bands are forbidden; if the selection rules were completely rigorous, only

E2 radiation would be observed. But as Alaga et al.²⁰ point out, small deviations from the rotational wave functions may serve to relax the K selection rule, which then acts to retard rather than completely eliminate the forbidden multipole.

We have attempted to explore, by means of the intensity rules, the nature of the small wave function admixtures by which the slow M1 radiation arises. It is possible that the M1 radiation proceeds because of a small amount of $K = 3/2$ character in the initial state or alternatively because of some $K = 3/2$ character in the (non-ground) levels of the $K = 1/2$ band. The theoretical reduced transition probabilities of the 210-, 228-, and 278-keV M1 transitions are calculated to be:

K_i	K_f	$B(210\gamma)/B(228\gamma)/B(278\gamma)$
3/2	1/2	0.3/1.0/0.9
5/2	3/2	0.2/1.0/2.3

The experimental ratio of reduced transition probabilities, 0.4/1.0/0.8, agrees fairly well with those calculated with $K_i = 3/2$ and $K_f = 1/2$. Thus, even though the upper band is principally $K = 5/2$, the M1 photons which (slowly) de-excite this level undergo branching as if they originated from a $K_i = 3/2$ level. (The second possibility, $K_i = 5/2$ and $K_f = 3/2$, seems unlikely in view of the disagreement with the experimental ratios. However, in this calculation we have assumed a constant mixing ratio in the three final states; since this is probably not a valid assumption²³ we cannot conclusively rule out this possibility.)

Level G is the only state of different parity from the ground state which has been identified in Pu²³⁹. This state de-excites principally by two gamma rays of 61.4 and 106.1 keV to the upper rotational band and by weak photons of 316 and 335 keV to the 5/2 and 7/2 levels of the

$K = 1/2$ band. The half-life of the level G is $0.19 \mu\text{sec}$,⁵ which corresponds to partial lifetimes for the 61- and 106-keV transitions of some 10^7 times the single proton estimate.²⁴ A further comment may be made about the 316- and 335-keV gamma rays: These high energy radiations are so weak relative to the 106-keV gamma ray that although we have no quantitative intensity estimates for them it is obvious that they are much more hindered than the 106-keV transition. This may indicate that the K quantum number of the odd parity state is $5/2$ or $7/2$, since in that event $E1$ transitions to any level in the $K = 1/2$ band will be K forbidden. An attempt was made to ascertain the K value of this state by a comparison of the experimental reduced $E1$ transition probabilities of the 61.4- and 106.1-keV transitions with those expected for various values of K_i (assuming $K_f = 5/2$), but the theoretical predictions were in this instance not sufficiently sensitive to K_i to overcome the large uncertainty in the experimental ratio.

VI. ESTIMATE OF AUGER COEFFICIENT FOR $Z = 94$

We have observed the K-X-Y Auger electrons resulting from the K conversion of the intense 210-, 228-, and 278-keV gamma rays. Because of the high fluorescence yield these lines are very weak compared with the conversion lines. However, by making a crude estimate of their intensities, we arrive at the figure:

$$(\text{total Auger int.})/(\text{total K-line int.}) = 0.02,$$

which is directly the Auger coefficient. This figure, although rough, is of the order of the expected value for high Z .²⁵

VII. BINDING ENERGY OF K ELECTRONS IN $Z = 94$

There is an appreciable uncertainty in the K shell electron binding energies for the very heavy elements.¹³ If we assume that the absolute uncertainty in the L shell binding energies is small, we can utilize our accurately measured K-L shell energy differences to arrive at a figure for the K shell energy. From the present data, our best value for the K shell binding energy in ${}_{94}\text{Pu}$ is 121.8 kev, which is the value given by Cauchois.²⁶

VIII. ACKNOWLEDGMENTS

We are deeply grateful to Professor John O. Rasmussen for the extensive assistance he has given us, especially with regard to the theoretical interpretation of the data. We wish to thank also Mr. D. Strominger for performing the coincidence experiments and Mr. F. J. Shon and others at the University of California Radiation Laboratory at Livermore for performing the pile irradiations. It is a pleasure to acknowledge the encouragement and interest of Professor Glenn T. Seaborg in this work. This work was performed under the auspices of the U. S. Atomic Energy Commission.

IX. REFERENCES

1. H. Slätis, Arkiv Mat., Astron. Fysik 35A, No. 3 (1948).
2. R. L. Graham and R. E. Bell, Phys. Rev. 83, 222 (1951).
3. Tomlinson, Fulbright, and Howland, Phys. Rev. 83, 223 (1951).
4. Freedman, Wagner, Engelkemeir, Huizenga, and Magnusson, private communication (Nov. 1952).
5. D. Engelkemeir and L. B. Magnusson, Phys. Rev. 99, 135 (1955).
6. Hollander, Perlman, and Seaborg, Rev. Mod. Phys. 25, 469 (1953).
7. Asaro, Thompson, and Perlman, Phys. Rev. 92, 694 (1953) and unpublished data.
8. Bleaney, Llewellyn, Pryce, and Hall, Phil. Mag. 45, 773, 991 (1954).
9. A. Bohr and B. R. Mottelson, Kgl. Danske Videnskab Selskab, Mat.-fys. Medd. 27, No. 16 (1953); K. Siegbahn, Editor, Beta and Gamma Ray Spectroscopy (Interscience Publishers, New York, 1955) p. 468.
10. W. G. Smith and J. M. Hollander, Phys. Rev. (in press).
11. H. C. Hoyt and J. W. M. Du Mond, Phys. Rev. 91, 1027 (1953).
12. P. P. Day, Phys. Rev. 97, 689 (1955).
13. Hill, Church, and Mihelich, Rev. Sci. Inst. 23, 523 (1952).
14. K. Siegbahn, Editor, Beta and Gamma Ray Spectroscopy (Interscience Publishers, New York, 1955), Appendix IV.
15. J. F. Schooley, University of California Radiation Laboratory Report UCRL-3038 (June, 1955).
16. J. O. Newton, private communication to J. O. Rasmussen (October 1955).
17. D. Strominger and J. O. Rasmussen, Phys. Rev. (in press).
18. W. G. Smith and J. M. Hollander, to be published.
19. J. G. Conway and R. D. McLaughlin, Phys. Rev. 96, 541 (1954).

20. Alaga, Alder, Bohr, and Mottelson, Kgl. Danske Videnskab Selskab, Mat.-fys. Medd. 29, No. 9 (1955).
21. Rasmussen, Stephens, Strominger, and Aström, Phys. Rev. 99, 47 (1955).
22. A. Simon, Oak Ridge National Laboratory Report ORNL-1718 Special (June 1954).
23. A. K. Kerman, Kgl. Danske Videnskab Selskab, Mat.-fys. Medd., to be published.
24. K. Siegbahn, Editor, Beta and Gamma Ray Spectroscopy (Interscience Publishers, New York, 1955), Chapter XIII.
25. P. R. Gray and G. T. Seaborg, to be published.
26. Y. Cauchois, J. Phys., Radium 13, 113 (1952).

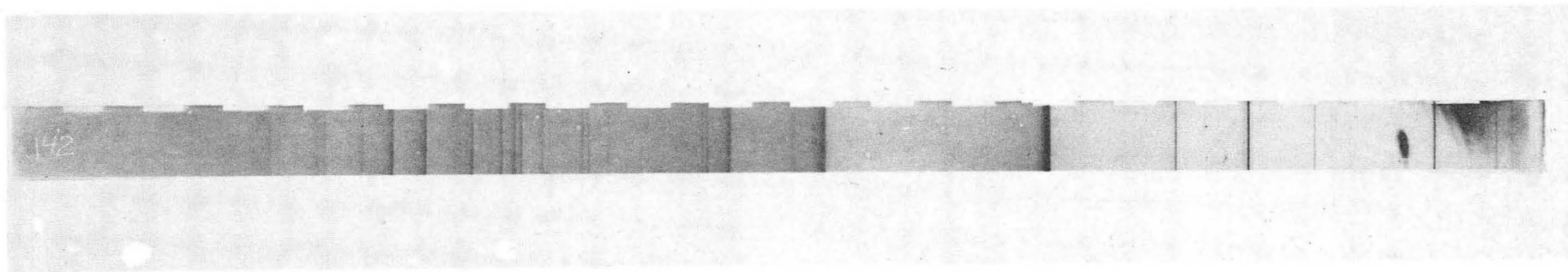

ZN-1407

Fig. 1. Reproduction of electron spectrogram of
Np²³⁹, taken on 100-gauss spectrograph.

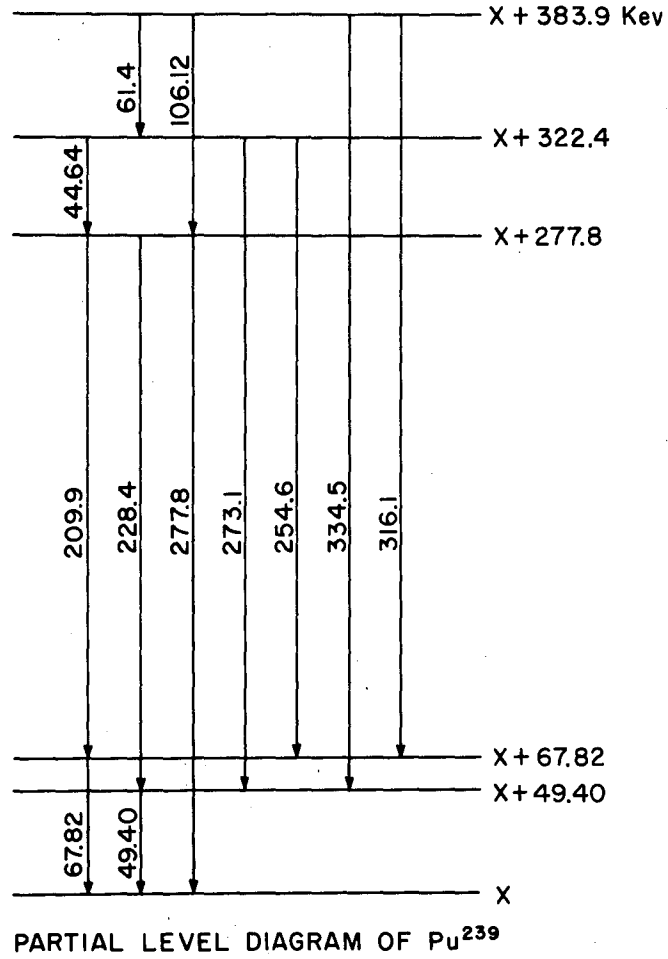

MU-10390

Fig. 2. Partial level scheme of Pu^{239}

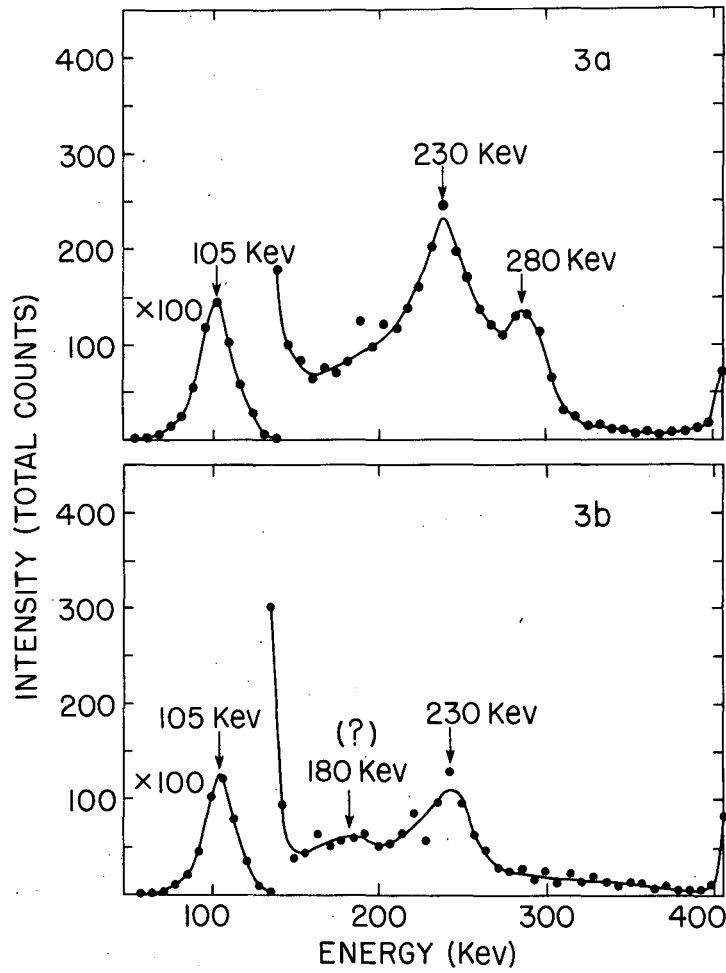

MU-10589

Fig. 3 Np^{239} gamma-gamma coincidence results.

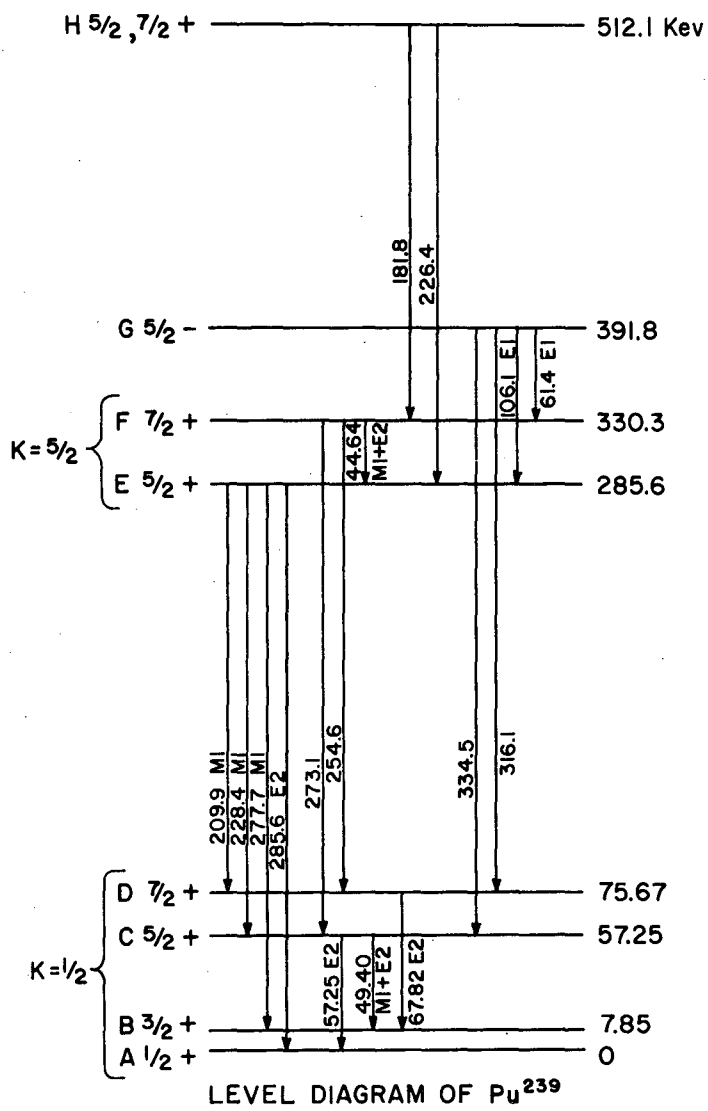

Fig. 4. Level scheme of Pu²³⁹.