

UC Irvine

UC Irvine Previously Published Works

Title

Droplet sizing interferometry: a comparison of the visibility and phase/Doppler techniques.

Permalink

<https://escholarship.org/uc/item/1298k8s8>

Journal

Applied Optics, 26(11)

ISSN

0003-6935

Authors

Jackson, TA
Samuelsen, GS

Publication Date

1987-06-01

DOI

10.1364/ao.26.002137

Copyright Information

This work is made available under the terms of a Creative Commons Attribution License, available at <https://creativecommons.org/licenses/by/4.0/>

Peer reviewed

Droplet sizing interferometry: a comparison of the visibility and phase/Doppler techniques

T. A. Jackson and G. S. Samuelsen

Spatially resolved measurements of droplet size and velocity are desirable to aid in matching fuel injectors to combustor flow fields and to support development of two-phase-flow modeling. Interferometric laser-based techniques have been available since the early 1970s. Successful application to practical sprays, however, has been hampered by numerous difficulties. In this paper, two interferometric techniques (visibility/intensity validation and phase/Doppler) are critically examined in characterizing the spray of an air-assist nozzle with Sauter mean diameter $< 35 \mu\text{m}$. The two techniques are compared to each other and evaluated against a Malvern diffraction unit. With the use of a rotating grating for frequency shifting, the interferometric techniques compare well with each other and to the diffraction method. Due to its broadened size and velocity ranges, the phase/Doppler technique is more easily applied to the spray than is visibility/intensity validation. The consistency of the interferometric results raises questions with regard to the use of Malvern's most frequently applied distribution model.

I. Introduction

The importance of detailed measurements within a spray field has become increasingly apparent. Traditional methods of spray characterization such as patternation, photography, and laser diffraction typically suffer from poor repeatability, are tedious to perform, or provide limited spatial resolution. Generally, they are inadequate for providing the detailed information required by those investigating two-phase phenomena such as spray combustion.¹

Laser interferometry has been suggested as a means of filling the measurement void.² In its original form the method relies on measuring the light scattered in the forward direction from a droplet (or particle) crossing the laser interference pattern. The visibility (or fringe contrast) of the collected signal varies as a function of the size of the scatterer. The technique can be successfully applied in conditions of low particle number density. However, in most sprays of practical interest the number density of the dispersed phase is unacceptably high for application of this method.

In 1980 a fundamental change in the visibility method was introduced.³ The modification called for an

off-axis collection of light refracted through non-opaque spheres. On the surface, the modification addressed two significant limitations of the original on-axis method. First, the detector could be used to control the size of the probe volume. Second, the off-axis collection circumvented the restriction imposed on the size range by the required beam stops of the forward scatter method. On a more fundamental level, other departures from the original technique emerged. First, since light is being transmitted by the droplet, the droplet cannot be opaque; the application of the sizing method becomes more narrowly directed. Second, the means of sizing is no longer based on a measure of the change in fringe contrast due to the presence of a scatterer in the interference pattern of the probe volume. Instead, the interference pattern is projected by the droplet toward the detector. The variation of the spacing of those fringes over the face of the detector provides a measure of the droplet size. The spatial variation of fringe spacing in the detector plane results from the relative phase shift that occurs between rays of light traveling through the droplet along paths of different lengths. The phase shift is directly proportional to the droplet diameter.³

Two instruments were introduced. The off-axis visibility instrument uses a single detector positioned 30° off the forward axis and out of the plane of intersection of the two transmitted beams. The spatial variation of projected fringe spacing over the detector face is integrated over the collection aperture. This integrated measurement of scattered intensity varies as the droplet moves, transmitting different sections of the probe

When this work was done both authors were with University of California, Department of Mechanical Engineering, Irvine, California 92717; T. A. Jackson is now with U.S. Air Force Aero Propulsion Laboratory, Wright-Patterson Air Force Base, Ohio 45433-6563.

Received 3 July 1986.

volume. This signal of oscillating intensity can be separated into its high-frequency (ac) and low-frequency (dc or pedestal) components. The ratio of these two components is the signal visibility and is analogous to the fringe contrast of the forward scatter interferometric instrument. Like its predecessor, the off-axis visibility is related to the droplet size through a Bessel function relationship. At a collection angle of 30° this limits the size range to $\sim 10:1$. The range can be moved by changing the optical setup.

Even with this improvement the technique suffers from nonuniform and random variations in the undisturbed interference pattern due to droplets interacting with the transmitted beams outside the probe volume.^{4,5} This, as well as other sources of error, prompted a further alteration to the original sizing method. A measurement of pedestal intensity (proportional to droplet diameter squared in the size range of interest) was incorporated as a check of the visibility measured size.⁶ Visibility/intensity validation (V/IV) has been tested and compared to the Malvern diffraction-based technique.⁷ Results indicated that V/IV can be successfully applied to a practical spray.

The second instrument, phase/Doppler (PD), utilizes the same scattering information on which the off-axis visibility is based. It is processed, however, to measure directly the phase shift of light encoded in the spatial variation of the fringes projected to the detector by the droplet. This is accomplished by utilizing three detectors to view simultaneously different portions of the collection lens. The output from each detector looks like a standard Doppler burst with high visibility. Their outputs, however, are slightly displaced in time because each is focused to a separate portion of the collection lens face. A more detailed description of the technique is available in the literature.⁸ Optically, the dynamic range of this method is 100:1. Detector gain limitations effectively restrict the range to 35:1, although this range can be positioned anywhere within the optically imposed limits.

In the work reported here, both techniques are applied to a water spray from an air-assist high-performance (low Sauter mean diameter) nozzle. A comparison of the performance of the techniques is presented. In addition, a diffraction-based droplet sizing instrument, the Malvern, is used to characterize the spray at identical operating conditions. A comparison of the interferometric systems to the diffraction system is made.

II. Experiment

A. Spray Facility

Tests were performed in a cold spray characterization facility. The arrangement is very flexible and has been described in detail.⁹ It consists of two major elements: fixed optics and a 2-degree of freedom nozzle fixture.

1. *Optics.* The pertinent optical paths used in this test are depicted in Fig. 1. For the interferometric instruments, a single transmitter is breadboarded. It

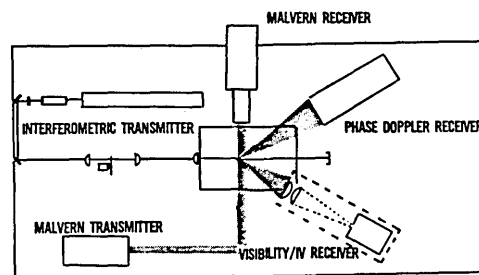

Fig. 1. Optical configuration.

utilizes a 5-mW He-Ne laser, a rotating diffraction grating (for frequency shifting and beam splitting), and appropriate lenses and mirrors. For a given lens arrangement, the grating (three tracks of different spatial frequencies) provides a choice of three different fringe spacings at the probe volume. The plane of polarization is normal to the plane of beam intersection. Detectors for both methods are placed in this plane at 30° off the forward axis. Figure 1 shows the detector arrangements for tests that could be performed without a spray confining chamber. The visibility detector is positioned to one side of the optic axis, the phase/Doppler detector to the other side. This enables both systems to operate simultaneously and in their preferred orientation. When confinement is necessary, both detectors are alternately positioned in the visibility detector location to utilize the only off-axis optical port of the confining chamber. In these cases simultaneity of measurement is sacrificed.

The optics are configured to give fringe spacings of $10.1 \mu\text{m}$ for all PD data, 7.5 and $14 \mu\text{m}$ for V/IV data. In all configurations, the beams are focused to a $100\text{-}\mu\text{m}$ diameter (to the $1/e^2$ intensity point) at the probe volume. The V/IV detector is fitted with a $100\text{-}\mu\text{m}$ diam aperture. Phase/Doppler uses a $50\text{-}\mu\text{m}$ by 1-mm rectangular slot; the long axis is normal to the optical axis. With 2:1 magnification within the receiver, however, the slot is effectively $100 \mu\text{m}$ wide.

The Malvern measurements are made using a model ST2200 along an optic path 90° from that of the radial point measurements (see Fig. 1). Only line of sight measurements through the spray center are made. The diffraction data are processed using the Rosin-Rammler (two-parameter) and model-independent (fifteen-parameter) algorithms. At the test condition, obscurations of 19–23% were typical at both axial stations reported.

2. *Nozzle Fixture.* The nozzle is a low-flow high-performance air-assist nozzle designed by Parker Hannifin. In making spray measurements, the nozzle is fitted to a 19-mm o.d. tube, plumbed with metered liquid and air circuits. This fixture sits vertically and concentric within a 34.3-cm inner diameter by a 152-cm long Plexiglas chamber. The annulus is supplied with metered air, and the chamber is evacuated at a rate to cause a slight suction across the open optical ports. Figure 2 illustrates schematically the spray chamber containing the nozzle fixture. For this test, the nozzle is operated with distilled water at a flow rate

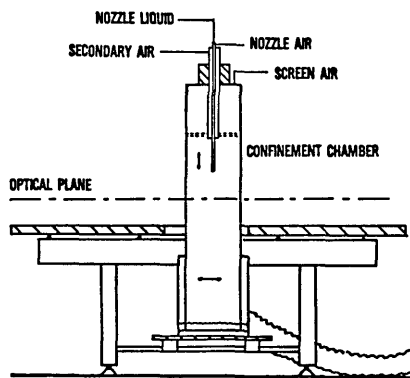

Fig. 2. Spray chamber.

of 3.02 kg/h and nozzle air-to-liquid mass ratio of 1.6:1. The velocity of screen air around the nozzle is 0.2 m/s.

B. System Calibration

The interferometric optics are checked utilizing a monodisperse droplet generator, the Berglund Liu. This device operates on the Rayleigh instability phenomena inherent to a column of liquid. The liquid flow rate and disturbance wavelength of the column are precisely controlled, permitting a high degree of control over the size of droplets broken off of the liquid column.¹⁰ Over a range of disturbance frequencies (corresponding to different droplet sizes) a stable stream of droplets of same diameter is produced and can be directed through the interferometric probe volume. This device is used to check the alignment of the optics and receiver parameters. Specifically, both techniques operate best when focused to the center of the probe volume. In addition, V/IV requires accurate setting of the gain to the photomultiplier tube (because of the intensity measurement); PD requires accurate specification of the spatial separation of the three regions of the receiver lens corresponding to the three detectors.

The Malvern diffraction instrument in principle does not require calibration. However, recent studies¹¹ with Laser Electro-Optics reticles quantified a source of error in some model ST2200s and older units in which variations in the response of the focal plane detectors to incident light were not adequately handled in software. This resulted in errors in the measurement of calibration reticles. The unit used in this effort was checked with these reticles and found to perform acceptably.

III. Results

Two sets of results are reported. Simultaneous interferometric measurements of an unconfined spray at ~15 mm from the spray center line and 50 mm off the nozzle face are presented. Then detailed characterization of the spray by all three instruments is discussed.

The interferometric instruments require corrections unique to their application. Furthermore, when com-

paring interferometric and diffraction data, adjustments to one or the other data set are required to make the comparison of the two types of data. In this paper, all corrections are made to the interferometric data. These are discussed.

First, the probe volume for the interferometric devices is formed by the intersection of two laser beams, each with a Gaussian energy profile. The resultant nonuniform probe volume energy distribution causes droplets of different diameters to be observable within probe volumes of different sizes. The instruments adjust the observed number of droplets of a given diameter to compensate for the probe volume differences. The V/IV technique relies on a theoretical description of the energy profile of the probe volume to generate the correction. The PD technique uses a proprietary real-time experimental-based correction. These corrections are applied to each run.

Second, the time required to collect the data at a given location in the spray varies with the droplet number density, size range, and velocity range; the spray field optical depth; and the memory capacity of the instrument. To compare data from one location to another, the number of droplets of each diameter are divided by the collection time of that run. Thus point-to-point comparisons are made on a frequency basis.

Third, if the instrument receiver gain changes appreciably in moving the probe volume from one location to another within the spray, comparisons between such points must account for the change in probe volume size resulting from the gain adjustment. The V/IV detector gain varies automatically to compensate for signal attenuation.⁹ During these tests, however, the variation of detector gain with probe volume radial position at a given axial location was insignificant. The PD instrument, however, uses the detector gain to optimize the position of its 35:1 sizing window imposed by the electronics within the 100:1 optically imposed dynamic range. Therefore, the detector gain of the PD unit is routinely adjusted at each probe volume position to optimize the sizing window for that spray location. The PD collection software generates a parameter representing the probe volume depth for each run. The probe volume width is set by the collection slit, and any variation in probe volume height is taken into account in the probe volume correction. The depth parameter (normalized by some convenient constant) is used in a manner analogous to the collection time to adjust the number counts of each measured diameter to a level consistent with having an equal size probe volume for all those runs to be grouped together.

Fourth, the interferometric data are temporal, while the Malvern data are considered spatial, consistent with recent ASTM definitions.¹² The primary flow direction of the spray is along the nozzle axis. It is this velocity component that the interferometric devices are oriented to measure. To convert the temporal interferometric data to the equivalent spatial measurements, the probe volume corrected count frequency of each diameter is divided by the mean velocity associated with that droplet diameter for each run.

Finally, the Malvern measurements for this evaluation are line-of-sight through the spray. A droplet size distribution is generated by a single run of this instrument through the center of the spray at both axial stations. (Note that each Malvern test point represents 1000 sweeps of the focal plane detector.) From the droplet size distribution, the Sauter mean diameter (SMD) and weight distribution of liquid can be computed. The equivalent information from the interferometric devices must be derived by making a series of point measurements along the path of Malvern measurement. The following expressions are used to compute line-of-sight spatial SMD and liquid weight distribution from the interferometric point measurements.

$$\text{SMD}_{\text{composite}} = \frac{\sum_j \sum_i d_{ij}^3 N'_{ij} / V_{ij} t_j}{\sum_j \sum_i d_{ij}^2 N'_{ij} / V_{ij} t_j}, \quad (1)$$

$$\text{WF}_{\text{composite}_i} = \frac{\sum_j d_{ij}^3 N'_{ij} / V_{ij} t_j}{\sum_j \sum_i d_{ij}^3 N'_{ij} / V_{ij} t_j}, \quad (2)$$

where d = drop diameter, μm ;
 N' = corrected number of drops with diameter d ;
 V = mean velocity of drops with diameter d , m/s ;
 t = time of collection for data set j , s ;
 i = index for drop diameters in each data set;
 j = index for the data sets being combined to form the composite.

A. Simultaneous Measurements

Measurements taken simultaneously with the two interference methods yielded similar results in both droplet size and velocity. Figures 3–5 are typical of the comparison. The size and velocity histograms of the two instruments have been replotted to the same scale. Both instruments observe similar spray characteristics. The profiles are not identical but overlap to a large degree. The dynamic range for droplet sizing with the PD unit is considerably broader than that of the V/IV technique, and the count frequency of the PD unit is substantially larger than that of V/IV. This is primarily due to the large rejection rate of V/IV (typically 99 vs. 30% rejections for V/IV and PD, respectively).

In Fig. 3, the size profiles have similar features. However, the V/IV unit (dynamic range of 8–85 μm) observes no droplets smaller than 32 μm . The PD device (size range 4.3–150 μm) observes a substantial number of droplets between 4.3 and 32 μm . The velocity histogram (Fig. 4) suggests a resolution of the measurement difference. The V/IV velocity measurements are sharply truncated at both the upper and lower ends of its range, indicating the velocity distribution of the observed drops is wider than the frequency band in use. The droplet size and velocity are highly

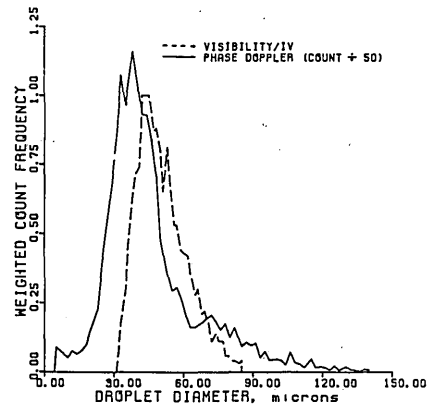

Fig. 3. Simultaneous interferometric measurements, size histogram.

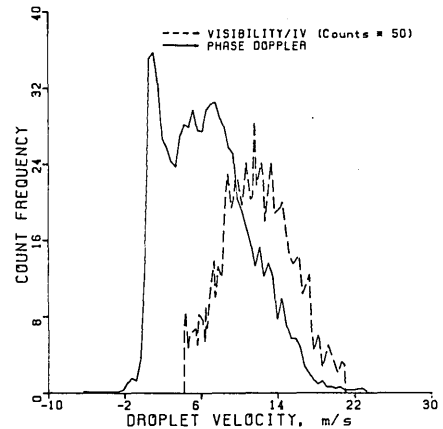

Fig. 4. Simultaneous interferometric measurements, velocity histogram.

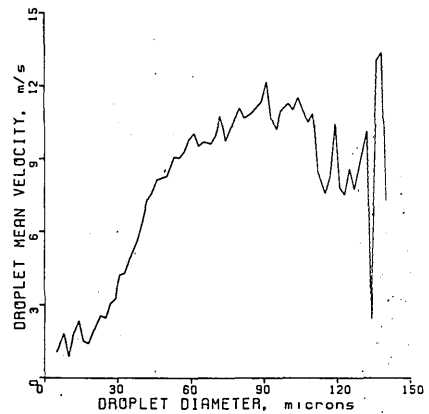

Fig. 5. Simultaneous interferometric measurements, size-velocity correlation (phase/Doppler only).

correlated at this location (Fig. 5). At ~ 4 m/s (the V/IV lower velocity limit) the droplet diameter is 32 μm . Thus V/IV was incapable of observing droplets between 8 and 32 μm because of the lower limit of its frequency band.

The size limitation of V/IV relative to PD is significant in this spray field. However, the apparent velocity range limitation of V/IV (i.e., Fig. 4) is somewhat

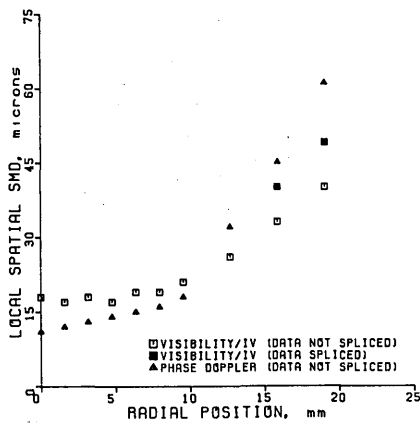

Fig. 6. Radial variation of droplet diameter, 30 mm axial.

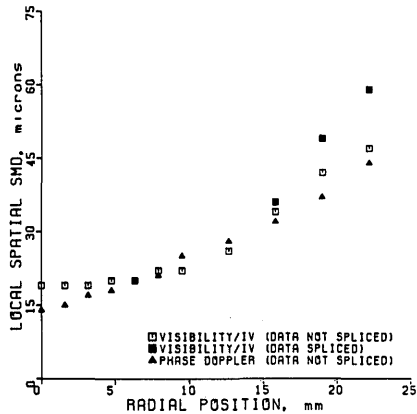

Fig. 7. Radial variation of droplet diameter; 50 mm axial.

misleading when the frequency shift is available. Shifting permits the use of broader higher-frequency band filters. For the spray conditions to be reported in the next section, neither instrument experienced a significant frequency dynamic range limitation.

B. Spray Characterization

The radial variation of the spatial SMD of the spray is depicted in Figs. 6 and 7 for axial positions of 30 and 50 mm, respectively. The correspondence between the two interferometric measurements is very good at both axial stations. Differences that surface are realistic in light of the relative limitations of the instruments. For the optical arrangements used, the lower sizing limits for PD and V/IV are 1.1 and 6 μm , respectively. The smaller droplets of the spray core are more easily seen by the PD unit. The large sizes, typical of the outer regions of the spray, are captured by PD with only an electronic change; V/IV requires an optic change to increase the fringe spacing to measure the droplets with diameters above 63 μm .

To cover the broad size range of the spray, V/IV requires the splicing of two or more data sets (of different size ranges). At 30 mm the outer two data points are each composites of two separate measurements; at 50 mm the outer three points are each composites of two or more data runs. In addition to being somewhat tedious, the required splicing of data sets introduces

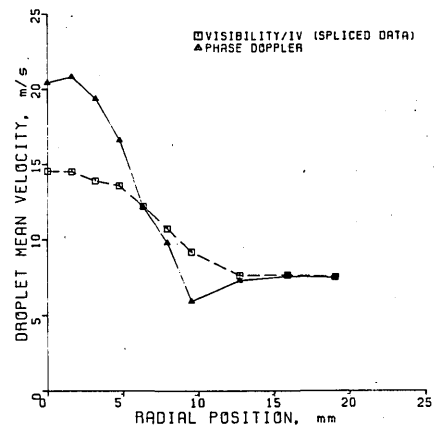

Fig. 8. Radial variation of droplet mean velocity, 30 mm axial.

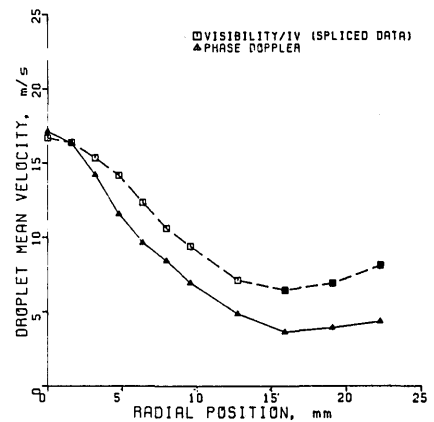

Fig. 9. Radial variation of droplet mean velocity, 50 mm axial.

potential error in that the method of splicing data points is uncertain. In this test, data are spliced by examining an overlap window of 23 μm (from 40 to 63 μm). A ratio is determined for each overlap diameter. That ratio represents the probe-volume-corrected number count frequency of drops of a given diameter for the run with a size range of 6–63 μm divided by the probe-volume-corrected number count frequency for the same diameter measured with the larger sizing window (11–118 μm). The arithmetic mean of all such ratios for the overlap region is determined. This mean value is multiplied by the probe-volume-corrected number count frequency of drops in each size group larger than 63 μm for the 11–118- μm data set; these data are spliced to the 6–63- μm information at the same location in the spray. This effectively creates a sizing window of 6–118 μm for the V/IV technique when required. At 30 mm the spliced points present no apparent problem. The spatial SMD varies smoothly outward. At 50 mm, however, there appears to be a shift in the data as the spliced sets are encountered. The shift is toward larger sizes.

Figures 8 and 9 depict the variation in droplet mean velocity with radial and axial position. Discrepancies between the instruments along the spray center line at 30 mm and near the spray edge at 50 mm are significant. There are three potential reasons for the differ-

ences. First, V/IV and PD may be observing different spray fields. The two measurements could not be performed simultaneously. Between the test series, the nozzle had to be disassembled and cleaned. It was not possible to be certain that on reassembly the nozzle components were in the same relative circumferential location. This nozzle is not fully axisymmetric.⁹ The V/IV and PD measurements may be along different radii of the spray.

Second, the velocity measurements may be biased by a limitation in the processing electronics. The advertised frequency limits of the PD and V/IV units were 3.2 and 5 MHz, respectively. Considering the fringe spacings and shift frequencies used along the spray center, the velocity limit of PD and V/IV should have been 32.2 and 28.1 m/s, respectively. The data indicate that the PD unit observed drops with velocity up to ~35 m/s. The V/IV unit generated velocity histograms with no evidence of velocities above its advertised limit. If the PD unit was exceeding its frequency limit, it should error by biasing the results toward low velocities. It does not. On the other hand, the spray is being ejected at velocities well in excess of the local ambient air velocity. Droplets at all locations are expected, in general, to decelerate as their axial distance from the nozzle increases. The V/IV measurement indicates the opposite (Figs. 8 and 9). Furthermore, the frequency response of both instruments has been checked. The PD unit behaves as expected. The V/IV instrument has a slight error at high frequencies. In checking the processor with a signal generator, the measured frequency is up to 10% lower than the input frequency when using the high end of the highest frequency bandpass filter. This error results in slightly lower measured velocities. However, the 10% error is not sufficient to explain fully the measurement discrepancy along the spray center line.

Finally, the velocity measurements may be biased by a limitation in the sizing window of an instrument. This would be true at a location where the droplet size and velocity are highly correlated and in which the range of drop diameters exceeds the measurement range of the instrument. Although the V/IV unit has a significantly smaller sizing window than does PD, the size velocity correlation along the spray center line is small; the V/IV sizing limitation is not a factor at this location.

The discrepancy in the edge measurements at 50 mm is likely due to the circumferential variation in the spray field and the fact that nozzle orientation in this regard is not repeatable after a nozzle disassembly and cleaning operation. Measurement differences along the center line are not fully explained. However, the V/IV measurements are suspect because the center line droplets appear to have accelerated in moving from 30 to 50 mm away from the nozzle, and a 10% processing error has been observed in the V/IV unit at high frequencies.

In Figs. 10 and 11 the spray data are examined in terms of their measured distribution of liquid weight. The Malvern results are included. Distributions from

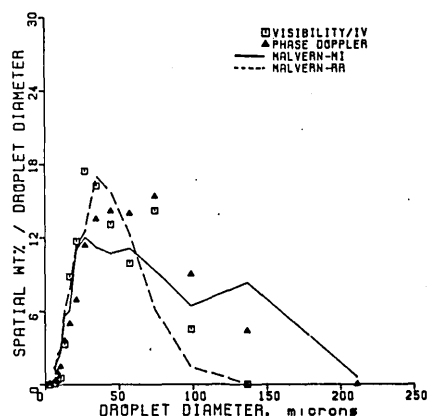

Fig. 10. Liquid weight distribution, 30 mm axial.

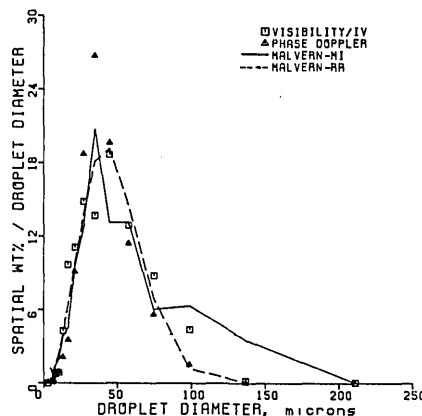

Fig. 11. Liquid weight distribution, 50 mm axial.

the point measurements are composites generated from Eq. (2). The Malvern curves are weight distributions generated from the far-field diffraction energy profiles using a two-parameter Rosin-Rammler (RR) and a fifteen-parameter model-independent (MI) algorithm. By Malvern standards, the fit of both models at both axial stations is acceptable. The distributions compare favorably to the point measurements; although the MI distributions seem to follow the interferometric generated forms more closely.

The two Malvern distributions are used to generate spatial SMDs at each axial station. In Table I, these are compared to the SMDs generated from a series of equispaced point measurements of the interferometric instruments. Correspondence between the interferometric composite values and the Malvern MI values is very good. Agreement with the Malvern RR SMDs is

Table I. Spatial SMD (microns) of the Spray as Measured by Diffraction and Interferometry

Instrument or algorithm	Axial position	
	(30 mm)	(50 mm)
Malvern RR	19.5	24.4
Malvern MI	28.3	30.7
Visibility/IV	31.3	31.9
Phase/Doppler	34.2	29.4

poorer, particularly at 30 mm. Since the interferometric values are generated from actual droplet counts and not based on a model of the distribution of liquid weight, as is the Malvern RR value, better agreement is expected between the MI value of SMD than with the RR value because of more degrees of freedom offered by MI. In previous work,⁷ the appropriateness of the Rosin-Rammler mode for the spray from this nozzle was questioned. Results in this program support the contention that this model does not fit this spray acceptably.

IV. Conclusions

The comparison of the phase/Doppler and visibility/intensity validation instruments indicates that both techniques yield very similar results in characterizing the spray of an air-assist nozzle. Also, both techniques yield measurements consistent with diffraction data. Specific conclusions of the test are as follows:

(1) PD and V/IV interferometric techniques can be successfully applied to a practical spray.

(2) The point techniques provide considerable information beyond that obtained with a diffraction unit. Droplet size and a single component of velocity can be obtained at precise locations within the spray.

(3) Point techniques can provide the ensemble-type measurements similar to the diffraction unit, although a series of point measurements are required along with suitable processing.

(4) Frequency shifting is an important feature of the point measurement systems. It enables most effective use of limited frequency bands (inherent in V/IV). Furthermore, it is essential in making comparisons to diffraction measurements. Flow regimes promoting significant droplet recirculation can be identified and avoided.

(5) The PD technique offers an advantage over the V/IV method in that it has a broader sizing capability, which generally precludes the need to splice data sets.

(6) The Rosin-Rammler treatment of diffraction data is not always appropriate. Point measurements may be used to determine the suitability of a distribution model for a particular spray.

This study is supported in part by the Air Force Engineering and Services Center, Research and Development Directorate, Environics Division (Air Force contract F0-8635-83-C-0052), and the Naval Air Propulsion Center (Navy contract N000140-83-C-9151). The United States government is authorized to repro-

duce and distribute reprints for governmental purposes notwithstanding any copyright notation hereon. The authors gratefully acknowledge (1) the assistance of H. Crum, V. McDonnell, R. Alexander, and M. Monroe in data collection and reduction, (2) the kindness of KVB Engineering and Aerometrics, Inc., for providing use of the Malvern and phase/Doppler units, respectively, (3) the cooperation of and technical discussions with W. D. Bachalo of Aerometrics, Inc., and C. F. Hess of Spectron Development Laboratories, Inc., and (4) Roma Bush for preparation of this manuscript.

References

1. A. A. Mostafa and S. E. Elghobashi, "Prediction of a Turbulent Round Gaseous Jet Laden with Vaporizing Droplets," Western State Section/Combustion Institute (1983).
2. W. M. Farmer, "Measurement of Particle Size, Number Density, and Velocity Using a Laser Interferometer," *Appl. Opt.* 11, 2603 (1972).
3. W. D. Bachalo, "Method for Measuring the Size and Velocity of Spheres by Dual-Beam Light-Scatter Interferometry," *Appl. Opt.* 19, 363 (1980).
4. A. J. Ferrenberg, "Liquid Rocket Injector Atomization Research," at ASTM Symposium on Liquid Particle Size Measurement Techniques (1983).
5. W. R. Seeker, W. D. Clark, and G. S. Samuelsen, "The Influence of Scale and Fuel Properties on Fuel-Oil Atomizer Performance," in *Proceedings, 1982 Joint Symposium on Stationary Combustion NO_x Control, Vol. 2*, Electric Power Research Institute Report, EPRI CS-3182,v2 (1982).
6. C. F. Hess, "A Technique Combining the Visibility of a Doppler Signal with the Peak Intensity of the Pedestal to Measure the Size and Velocity of Drops in a Spray," AIAA-84-0203, AIAA Twenty-second Aerospace Sciences Meeting, Reno, NV (1984).
7. T. A. Jackson and G. S. Samuelsen, "Spatially Resolved Droplet Size Measurements," *J. Eng. Gas Turbines Power* 108, 196 (1986).
8. W. D. Bachalo and M. J. Houser, "Development of the Phase/Doppler Spray Analyzer for Liquid Drop Size and Velocity Characterizations," AIAA-84-1199, AIAA/SAE/ASME Twentieth Joint Propulsion Conference, Cincinnati, OH.
9. T. A. Jackson, "Spatial Characterization of Droplet Size and Droplet Velocity in a Liquid Atomized Spray," Ph.D. Dissertation, U. California, Irvine (1985).
10. R. N. Berglund and B. Y. H. Liu, "Generation of Monodisperse Aerosol Standards," *Environ. Sci. Technol.* 7, 147 (1973).
11. E. D. Hirleman and L. G. Dodge, "Performance Comparison of Malvern Instruments Laser Diffraction Drop Size Analyzers," presented at the International Conference on Liquid Atomization and Spray Systems (ICLASS), London, England (1985).
12. ASTM STD E799-81, "Data Criteria and Processing for Liquid Drop Size Analysis," (1982).