

Lawrence Berkeley National Laboratory

LBL Publications

Title

Pathways to the Next-Generation Power System With Inverter-Based Resources: Challenges and recommendations

Permalink

<https://escholarship.org/uc/item/13j5p663>

Journal

IEEE Electrification Magazine, 10(1)

ISSN

2325-5897

Authors

Lin, Yashen
Eto, Joseph H
Johnson, Brian B
[et al.](#)

Publication Date

2022-03-01

DOI

10.1109/mele.2021.3139132

Peer reviewed

Pathways to the next generation power system with inverter-based resources

By Yashen Lin, Joseph H. Eto, Brian B. Johnson, Jack D. Flicker, Robert H. Lasseter, Hugo N. Villegas Pico, Gab-Su Seo, Brian J. Pierre, Abraham Ellis, Jeremiah Miller, and Guohui Yuan

1 Introduction

Managing the stability of today's electric power systems is based on decades of experience with the physical properties and control responses of large synchronous generators. Today's electric power systems are rapidly transitioning toward having an increasing proportion of generation from nontraditional sources, such as wind and solar (among others), as well as energy storage devices, such as batteries. In addition to the variable nature of many renewable generation sources (because of the weather-driven nature of their fuel supply), these newer sources vary in size—from residential-scale rooftop systems to utility-scale power plants—and they are interconnected throughout the electric grid, both from within the distribution system and directly to the high-voltage transmission system. Most important for our purposes, many of these new resources are connected to the power system through power electronic inverters. Collectively, we refer to these sources as inverter-based resources.

The operation of future power systems must be based on a combination of the physical properties and control responses of traditional, large synchronous turbine generators as well as those of inverter-based resources (see Figure 1). The major challenges stem from the recognition that there is no established body of experience for operating hybrid power systems with significant amounts of inverter-based resources at the scale of today's large interconnections.

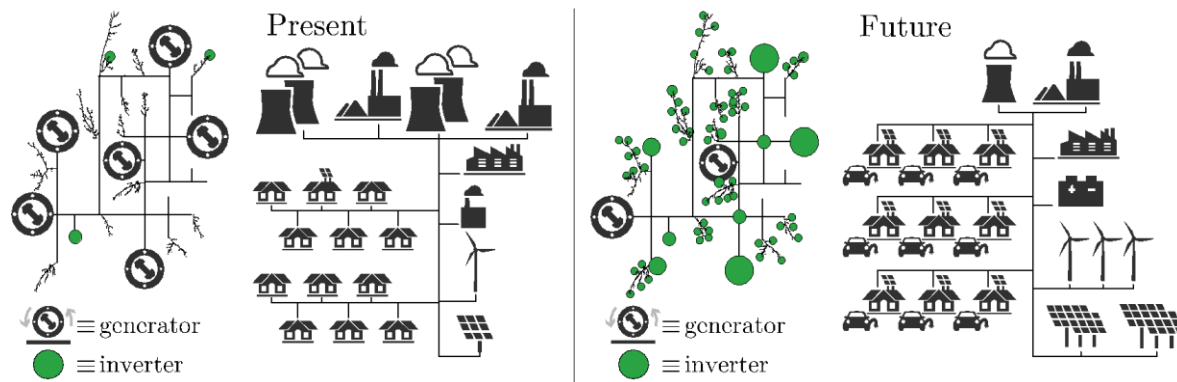

Figure 1. The present power system (left) has historically been dominated by synchronous generators having large rotational inertia with a relatively modest amount of inverter-based resources, such as PV, wind, and batteries. Future systems (right) will have a significant fraction of generation interfaced with power electronics and might be dominated by inverters. This implies a need for next-generation grid-forming controllers that ensure grid stability at any level of penetration with inverter-based resources.

To operate such large hybrid power systems, the assumptions that underlie current generation design and control approaches must be reexamined and, where appropriate, modified or even

redefined to take explicit account of the new challenges and opportunities presented by these inverter-based forms of generation. We should expect that new control approaches, operational procedures, protection, and planning tools and processes will be required.

Synchronous generators regulate their terminal voltages and respond to changes in grid frequency through changes in their power output. We refer to these generation sources as *grid-forming*. Today's inverter-based generation sources generally use phase-locked loops (PLLs), which rely on externally generated voltages from synchronous machines to operate. We refer to these types of inverter-based generation as *grid-following* inverters. In case of unintended separation of the power system or after a blackout, islanded systems comprised of only these types of inverters cannot operate autonomously. This limitation of the grid-following inverters has inspired an investigation into grid-forming control methods for power electronic inverters, which provide functionalities that are traditionally provided by synchronous machinery. Early work on this topic started in the 1990s focusing on power systems with small footprints (e.g., microgrids) and on small islands (such as Kauai, Hawaii). Today, grid-forming controls are being considered for deployment in bulk power systems because of their ability to enhance the stability of these grids when loads are largely being served by inverter-based resources.

This article reviews the challenges involved in integrating inverter-based resources into the electric power system and offers recommendations on technology pathways to inform the academic community, industry, and research organizations. In the following sections, we will (i) discuss the difference between grid-following and grid-forming control approaches for inverter-based resources; (ii) review relevant research and outline research needs related to five grid-forming inverter topics: frequency control, voltage control, system protection, fault ride-through (FRT) and voltage recovery, and modeling and simulation; and (iii) introduce a roadmap that outlines an evolutionary vision in which grid-forming inverters play a growing role in power systems that in turns leads to the identification of nearest term priorities for research. This article builds upon the Research Roadmap on Grid-Forming Inverters¹, interested readers are encouraged to read the roadmap for more detailed discussions.

2 Overview of Grid-Following and Grid-Forming Controllers for Inverter-Based Generation

In this section, we provide an overview of grid-following and grid-forming for inverters. Before delving into the characteristics of these two control types, we refer to Figure 2 which provides a functional overview of a conventional grid-following controller and a few implementations that provide grid-forming functions. Furthermore, Table 1 provides a convenient summary of the distinguishing characteristics between these two main control types.

¹ Lin, Y., Eto, J.H., Johnson, B.B., Flicker, J.D., Lasseter, R.H., Villegas Pico, H.N., Seo, G.S., Pierre, B.J. and Ellis, A., 2020. *Research Roadmap on Grid-Forming Inverters* (No. NREL/TP-5D00-73476). National Renewable Energy Lab.(NREL), Golden, CO (United States).

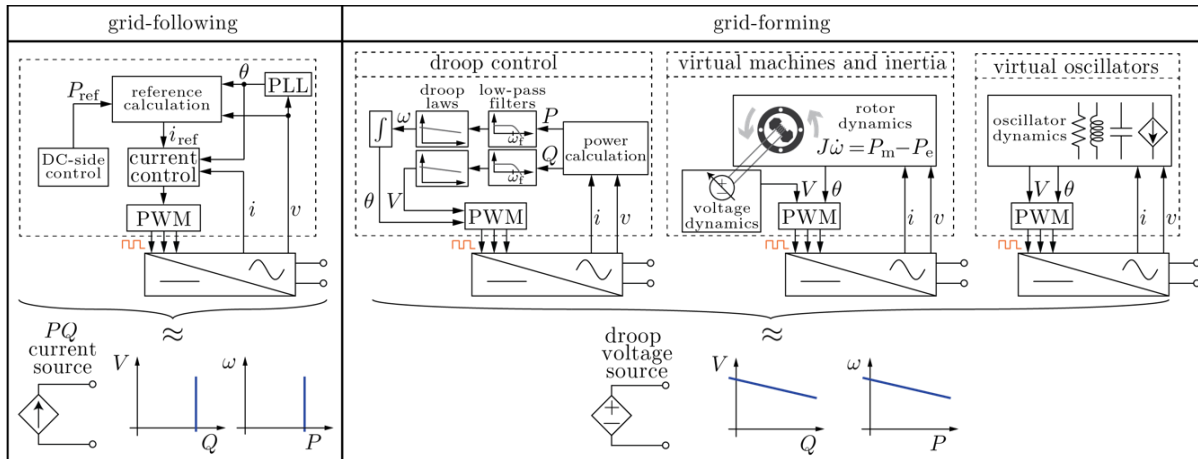

Figure 2. Functional diagrams of grid-following and grid-forming inverters. Grid-following inverters mimic current sources at their output terminals, whereas grid-forming inverters act like voltage sources whose output abides by droop laws.

Table 1. Comparison of Grid-Following and Grid-Forming Controls

| Grid-Following Control | Grid-Forming Control |
|--|---|
| Assumes grid already formed under normal operations | Assumes converters must actively form and regulate grid voltages |
| Control of current injected into the grid | Control of voltage magnitude and frequency/phase |
| Decoupled control of P and Q | Slight coupling between P and Q |
| Needs PLL | It may use PLL control to switch between modes |
| Needs voltage at the point of common coupling to deliver P and Q | Can black-start a power system |
| <i>Cannot operate</i> at 100% power electronics penetration; instability thresholds (tipping points) exist | <i>Can theoretically operate</i> at 100% power electronics penetration; can coexist with grid-following |
| | Not standardized, inadequate operational experience at a systems perspective |

2.1 Grid-following controllers

This control strategy is called grid-following since its functionality depends on a well-defined terminal voltage that a PLL can reliably measure. In this setting, it is assumed the system voltage profile and frequency are tightly regulated by external resources and grid equipment. As the proportion of the grid-following inverters on a grid increases, it might be necessary to embed additional functions, i.e., grid-support functions, to prevent excessive voltage and frequency deviation. Since almost all grid-connected inverters are grid-following today, their properties will be key to understanding grids at the moment and in the coming years.

2.2 Grid-forming controllers

From here forward, the term *grid-forming* acts as an umbrella for any inverter controller that (i) regulates terminal voltages, (ii) can coexist with other grid-following and grid-forming inverters and synchronous generation on the same system, and (iii) does not require a PLL or communications to operate together with multiple grid-forming assets. As shown in Figure 2, grid-forming controllers can be broadly categorized as droop, virtual synchronous machines, and virtual oscillator controllers. Droop control is the most well-established grid-forming method as it was conceived in the early 1990s. Its key feature is that it exhibits linear trade-offs, often called *droop laws*, between real power versus frequency and reactive power versus voltage. This mirrors how synchronous machines operate in steady state. They give rise to the following properties regardless of whether they are machines or inverters:

- system-wide synchronization: all units reach the same frequency;
- power sharing: each unit provides power in proportion to its capacity.

Virtual synchronous machine control replicates the dynamic behavior of a synchronous machine with an inverter. The complexity of the emulate virtual machine can vary greatly, from detailed models to simplified swing dynamics. Implementations that closely match machine characteristics have both Q-V and P- ω characteristics and are often called *Synchronverters*. Virtual inertia methods are simpler and capture only the dynamics of an emulated rotor and its steady-state P- ω droop.

Virtual oscillator control is another inverter control method that emulates nonlinear oscillators. As illustrated in Figure 2, the model takes the form of an oscillator circuit with a natural frequency tuned to the nominal ac grid frequency and its remaining parameters tuned to adjust the nominal voltage and control bandwidth. Despite its unconventional appearance, it exhibits the Q-V and P- ω droop laws in steady state that the other grid-forming methods also offer. However, its simple time-domain implementation and dynamical properties offer enhanced speed.

3 Inverter Control State-of-the-Art and Open Research Questions

In this section, we review relevant research and outline research needs related to the following five topics: frequency control, voltage control, system protection, fault ride-through (FRT) and voltage recovery, and modeling and simulation.

3.1 Frequency Control

Frequency control refers to generation control actions designed to maintain system frequency near the nominal value. In machine-based grids, system inertia strongly influences frequency dynamics and physically originates from the rotating masses of machine-based generators. Since inverter-based resources do not contribute inertia to a power system, it follows that the replacement of machines with inverters will reduce system inertia and may increase the risk of large frequency swings. Figure 3 illustrates the relationship between decreased machine capacity

and increased frequency deviations across time. To address this concern, grid-forming inverters may be used to counteract both the loss of inertia and primary frequency control provided by retired synchronous generation. Similar to the natural behavior of synchronous machines, grid-forming inverter-based resources would autonomously react to frequency swings and autonomously adjust their power injections during a low frequency event.

Reduced inertia may result in a larger rate of change of frequency and increasingly volatile system dynamics, and it also necessitates faster control actions to arrest frequency swings. Because the magnitude of the frequency swing after a disturbance is largely tied to the imbalance between generation and load, enough untapped capacity must be reserved as headroom for frequency control. A drawback is that unused capacity could represent an opportunity cost for both renewable and fossil-fueled generation because power output must be throttled to less than the available amount.

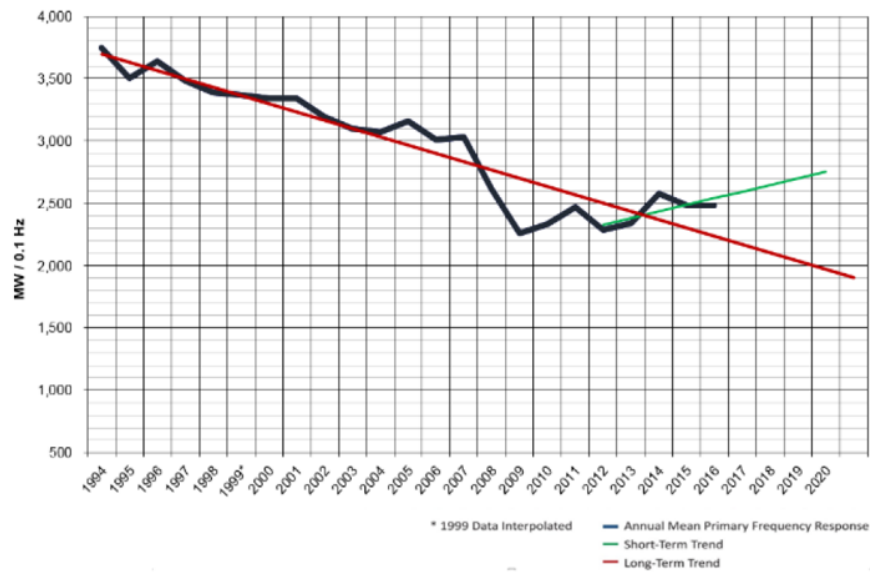

Figure 3. Decreasing total system inertia for the Eastern Interconnection²

Referring to the controllers shown in Figure 2, we provide a brief survey of existing frequency control strategies. P-omega droop offered by grid-forming units would govern the steady-state frequency deviation after initial transients have subsided. Typically, these relations are tuned such that the frequency stays within a narrow range near the nominal value. There are established control strategies for inverter-based microgrids, which are similar in spirit to hierarchical control methods in classic power systems. In particular, the droop slope at each inverter can be adjusted for the desired primary response at the timescale of tens of milliseconds to seconds, and schemes using low-bandwidth communications have been used for secondary frequency restoration within seconds to a few minutes, and, lastly, tertiary-level energy dispatch offers further control across

² Source: North American Electric Reliability Corporation (NERC). 2017. *State of Reliability 2017*. Atlanta, GA.

minutes to hours. This suite of methods can be used to manage energy on a microgrid using different types of inverter controls with setpoints.

Although grid-forming controllers have similar steady-state characteristics, distinctions arise when comparing how each grid-forming controller reacts dynamically at the shortest timescales. The most rapid response of a droop controller is dominated by filters, usually low-pass and/or notch filters, used to remove harmonics and pulsating components from the measured signals. Therefore, in droop designs, careful trade-offs must be made between harmonics and speed while ensuring stability. In a virtual synchronous machine, the underlying machine model parameters dictate its dynamic response. In particular, the damping, inertia, and flux-linkage parameters are virtual, and they can be designed for the desired response. The response of virtual oscillator control is tuned by the selection of the virtual circuit parameters. The virtual oscillator is relatively simple, and its parameters can be unambiguously computed from a set of AC system performance specifications, such as droop slopes, response time, and inverter rating. Grid-following inverters can be programmed to mitigate their contribution to frequency swings by supplementing the current controller with *frequency-watt* functions. They have been used in several grids including Hawaii's. This function, which mimics the P-omega droop law, has been compared directly to grid-forming droop control via simulation studies.

3.2 Voltage Control

Voltage control refers to generation control actions to increase or decrease real and/or reactive power production and network switching operations (either dynamic or static) that aim to maintain power system voltages within an acceptable range. The control requirements for these actions depend on the topology of the transmission or distribution system, the electrical distance between loads and generation, and the loading on the transmission or distribution system. Voltage control must be exercised through actions that are local to the voltage issues they seek to manage. Generally, voltage control via real power is not preferred given enhanced voltage sensitivity to reactive power control, and moreover generator revenue, which is mostly, if not entirely, via real power production.

Voltage regulation describes the ability of a system to provide near constant voltage over a wide range of variable load and generation conditions. Passive voltage change, a drop or rise, takes place under various load conditions. All conductors in power systems have intrinsic impedance that results in a variable voltage profile along the length of the line when current flows. Active voltage intervention (increasing or reducing voltage to preferred operational limits) might use electromechanical or electronic components, from generators to other devices. Such devices include load tap changers, voltage regulators, capacitor banks, synchronous condensers, and others, along with early-stage commercialization of solid-state technology (power electronics), e.g., static synchronous compensator.

For synchronous generators, their automatic voltage regulator (AVR) adjusts output voltage either by adjusting power delivery via the main field or real and reactive power output by modulating the exciter field current. Voltage stability and reactive power sharing among parallel-connected synchronous generators is achieved via Q-V droop control such that each machine follows a linear relationship between reactive power and voltage.

Grid-forming inverters natively provide voltage regulation via their Q-V droop laws, often called volt-volt ampere reactive (volt-VAR) control, which closely matches the behavior of synchronous machines. Mirroring terminology from frequency control, this is generally called primary voltage control to emphasize that these control actions are done locally, without communication. Thus, grid-forming inverters can be especially helpful in providing voltage support in weak grids.

Recent advances in voltage control for inverter systems are mostly concentrated in microgrid systems with droop control. Virtual impedances have been used to improve reactive power sharing and to mitigate parameter sensitivity. To further enhance reactive-power sharing and reduce steady-state errors, communications-based secondary-level controllers have been proposed. However, novel methods should be devised for deployment in bulk power systems to reduce communication dependency for scalability and resilience.

Recent findings have also uncovered adverse interactions between grid-forming inverters and synchronous machine excitation systems that regulate voltages, and similar issues have been observed on grid-following control types. These interactions can destabilize hybrid systems and appear to be common to both grid-following and grid-forming inverter controls.

Interactions and voltage oscillations may occur in systems of grid-following with grid-support functions. Here, the piecewise linear volt-VAR relations on grid-following inverters and the time delays and filters used to tune volt-VAR control actions are known to introduce undesired interactions between grid-following inverters and voltage regulation equipment. Methods to mitigate interactions between all types of inverter controls and other generation should be investigated for inverter-dominated grids.

3.3 System Protection

The effect of grid-forming inverters on power system protection is fundamentally different than that of grid-following inverters and has not been extensively studied. In theory, the fault current from grid-forming inverters, though it may vary by the control schemes, may have a subtransient behavior that more closely mimics synchronous machines and is significantly larger than that supplied by grid-following inverters. The short-circuit currents from grid-forming inverters can be equivalent to synchronous generation but are normally constrained to 4–6 p.u. for short time periods (<10 cycles) before steady-state limits (<2 p.u.) are imposed. Larger short-circuit subtransient response will be limited primarily by the short-circuit response of componentry in the grid-forming inverters, related to its internal impedance. Brief time period short-time response is limited by semiconductor ratings, whereas the steady-state response is by inverter hardware parameters, e.g., thermal management.

Traditional three-phase grid-tied inverter controls will not provide zero- or negative-sequence currents by design, which can be used to identify unbalanced fault conditions more easily; inverter controls are designed to suppress negative-sequence current. It is recommended to program grid-forming inverters to source zero- and negative-currents, mimicking a fault behavior of synchronous machines, in an unbalanced fault condition. This would yield an increase in the efficacy of traditional protection mechanisms compared to the pure grid-following control case and would significantly simplify the identification of unbalanced faults.

A protection issue unique to grid-forming inverters is operation in islanded/microgrid mode when a portion of the power system is disconnected from the bulk grid. Traditional grid-following inverters automatically shut off in an islanded condition, with absence of an external voltage, but grid-forming inverters can continue to operate islanded from the area grid (in many cases, such resilient microgrid operation is a primary benefit to grid-forming inverters). To maximize the benefit, some form of islanding protection will be still needed for grid-forming inverters to safely operate in islanded mode while ensuring the safety of electrical personnel and other bystanders. This must be balanced by the need for system resilience because islanded operation is a key benefit of grid-forming inverters as a response to widespread catastrophic events. A robust set of standards is necessary to balance autonomous grid-forming operation in grid-connected mode and islanded/microgrid operation as well as during line maintenance by electrical personnel.

Although synchronous generation has well-defined and predictable currents and voltages during transient events (or well-understood models/experimental testing) that allow for protection engineers to ensure subtransient and transient reactance are within system specifications, no well-defined set of models and tests are provided from inverter manufacturers. Detailed analytic modeling and simulation efforts, similar to those already underway for grid-following controls, are needed to examine the effects of grid-forming implementations on power system protection and provide a consistent framework for protection design for inverter installations. A robust standards ecosystem that can mandate the consistent behavior of grid-forming inverters from different manufacturers to the same contingency scenarios is needed to obtain reliable protection of grids. Without such a framework, protection engineering must carry out extensive studies on inverter behavior or extensive redesign of the protection system, which increases the risk, complexity, and cost of inverter installations. In addition, we must explore whether today's protection schemes are appropriate and effective long-term solutions for a grid with grid-forming and grid-following inverters or whether a paradigm shift is needed to fully benefit from the fast dynamics of power electronics inverters.

3.4 Fault Ride-Through Capability and Power System Voltage Recovery

Transmission faults can cause deleterious electromagnetic transients which propagate throughout a geographic area. During and after such events, it is desired that generating resources are capable of: (i) withstanding such deleterious transients and (ii) driving the grid to a new operating point by regulating terminal voltage magnitudes and frequency. This ability is referred to as voltage ride-through, disturbance ride-through, or fault-ride through capability. The North American Electric Reliability Corporation (NERC) standard PRC-024-3 mandates all generating resources to remain connected during defined voltage and frequency excursions to support the Bulk Electric System. Figures 4 and 5 illustrate classes of PRC-024-3 time-duration envelopes that enclose a set of positive-sequence voltage magnitudes and frequency that shall be tolerated by generation resources in a variety of interconnections. Notably, voltage and frequency requirements in the Quebec interconnection can be more challenging to satisfy than those for the Eastern, Western, and ERCOT interconnections because the Quebec envelopes are more permissible.

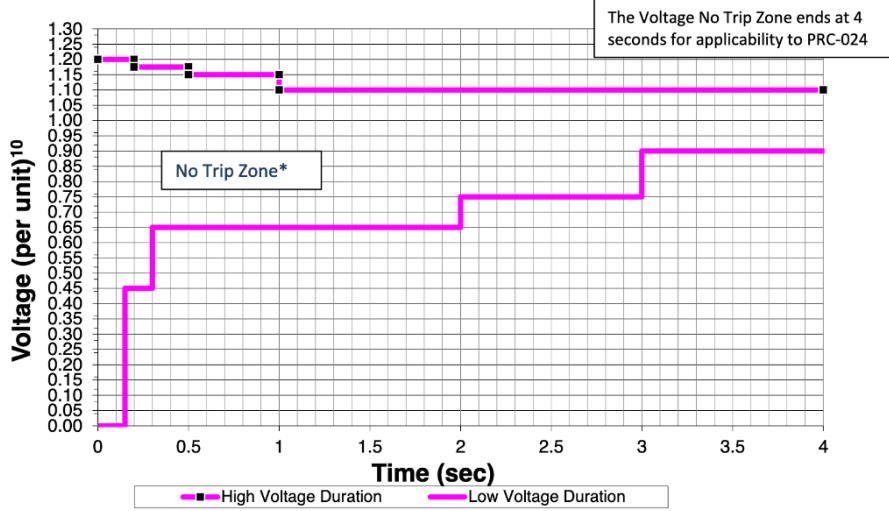

(a) Eastern, Western, and ERCOT

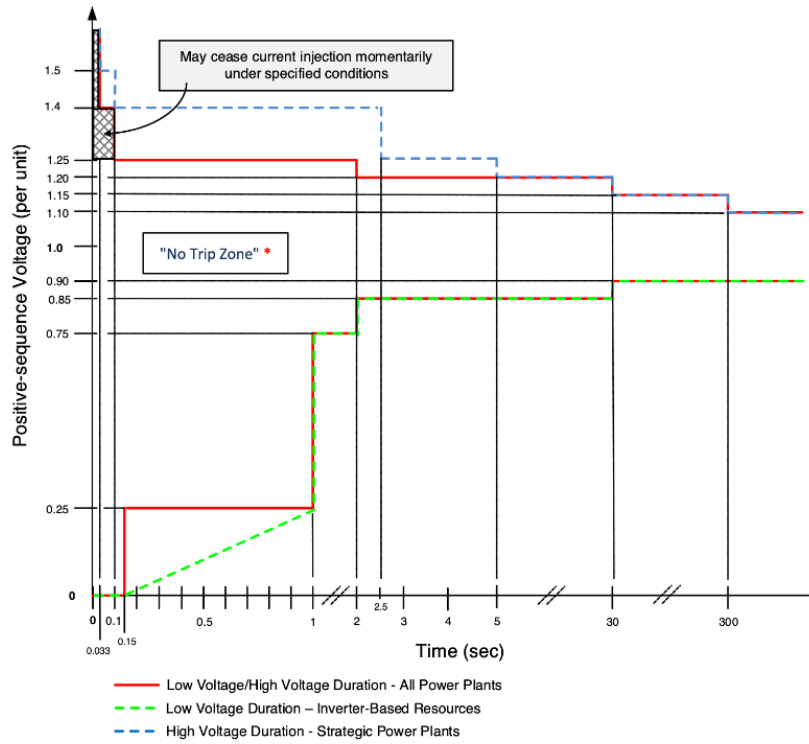

(b) Quebec

Fig. 4. Voltage No-Trip Boundaries of the North American interconnections³.

³ Source: North American Electric Reliability Corporation (NERC). 2020. *Std. PRC-024-3: Generator Frequency and Voltage Protective Relay Settings*. Atlanta, GA.

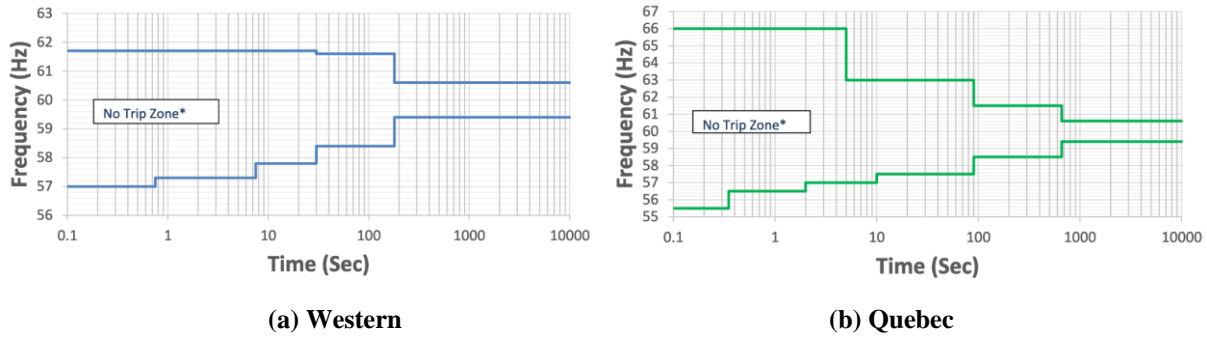

Fig. 5. Frequency No Trip Boundaries by Interconnection⁴.

A limitation of present grid codes is that they are conceptualized from observations of modern power system which are dominated by synchronous machines. If a significant number of inverter-based generation displaces synchronous machinery, such voltage recovery ability might be challenged. In contrast to synchronous generators that can supply relatively large off-nominal currents for short periods of time, power inverters have hard current limits that could greatly restrict the current dynamic voltage recovery capability of future power grids. For example, inverter-based generation might be limited to support the voltage recovery of grids with high penetrations of motor loads, which might slow down the voltage recovery because of high inrush current. Hence, inverter-based generation with grid-forming control might need to operate under low-voltage/high-current conditions for longer times than they do today.

To timely tackle the aforementioned problems, it is critical to investigate a suitable set of FRT envelopes that inverter-based systems might have to tolerate in the future. In particular, it could be beneficial to determine a current ride-through envelope that serves to engineer inverters that tolerate motor stalling events, for example. Other problems to address pertain to the development of analysis tools to ascertain compliance of grid-forming controls in the context of FRT codes, determining disturbances that drive a set of grid-forming inverters outside a non-tip zone, coordination with protective relays, and feasibility of communication-less protection systems for fast response.

3.5 Modeling and Simulation Approaches

A common assumption applied to a wide range of modern simulation tools is that a power system has a hypothetical synchronous reference speed—i.e., center-of-inertia speed—that remains relatively close to nominal (e.g., rad/s) during and after a transient. Consequently, the power transmission network has been classically represented by an abstract algebraic system in which electrical variables are sinusoids cycling at this reference speed.

Such an assumption is justifiable in classic systems because synchronous machinery with relatively large rotor inertia constants can maintain close to nominal rotor speed during and after

⁴ Source: North American Electric Reliability Corporation (NERC). 2020. *Std. PRC-024-3: Generator Frequency and Voltage Protective Relay Settings*. Atlanta, GA.

faults. Increased inverter-based generation might invalidate the constant frequency assumption because of the lack of rotating inertia. Specifically, the cycling speed of generated voltages by inverters with controls such as droop and virtual oscillator control might change abruptly during faults. This can occur because the cycling speed of these controllers depends on the instantaneous power/current. For example, AC power provided by an inverter could be as low as zero during faults.

Because of the high computational burden of large-scale electromagnetic transient simulations, synchronous model and positive-sequence simulations are a desirable tool for bulk power system studies. Thus, there is an important need for appropriate inverter-based generation models for existing positive-sequence simulation tools. Currently, such models are usually highly simplified and often are not able to accurately capture the behavior of the system. Recently, the importance of improving the grid-following model to capture this behavior has been recognized which also applies to grid-forming inverters.

An additional problem when simulating inverter-based generation in power system simulations is that the characteristics of primary energy sources, such as wind turbines and PV arrays, are typically omitted. Incorporating these energy sources is important in a simulation because they are useful to determining whether generation will be able to meet demand after a large transient. At present time, positive-sequence models such as the DER_A neglect primary energy sources.

Another challenge in modeling inverter-based generation is that compared to synchronous machines, many types of inverter-based generation are small, large in numbers, and connected to the grid at the distribution level. A research problem pertains to determining a suitable representation of many heterogeneous inverter-based generation in bulk power system simulations. One way to bridge this gap is to start with a small unit and design a scaling law to model a collection of units. Another approach is to use system identification methods to develop gray-box models directly at the feeder-head level.

An additional problem pertaining to the integration of inverter-based generation is that the primary energy sources are variable and thus uncertain. This implies that a framework is needed to assess uncertain dynamic simulations. If uncertainties are not considered in simulations, deterministic simulations might be unable to predict adverse dynamic behavior introduced by variable initial conditions and inputs. At the present time, a variety of tools have been proposed that are capable of handling uncertainties such as trajectory sensitivity, probabilistic collocation, semidefinite programming, Lyapunov function families, and Taylor polynomials. However, a common problem with these tools is the curse of dimensionality.

4 Roadmap for the Development and Deployment of Grid-Forming Inverters

Section 3 reviewed the present state of research on power system stability, protection, and modeling/simulation for grid-forming inverters. It outlined a wide range of open research questions that must be addressed. This section integrates and recasts these research questions in the form of a roadmap that outlines near- and long-term research priorities.

In the near term, significant additional research, development, and field trials of grid-forming inverters are needed to build on and expand early, promising research findings on the opportunities for increased grid control with inverter-based forms of generation and storage. In the midterm, priorities will begin to shift (and in some instances have already shifted) to focus on the opportunities for grid-forming inverters to contribute materially to the performance of specific types of grids whose performance cannot be improved through other, less expensive means (such as weak grids with low short-circuit strength). Through these early-stage deployments, consensus will begin to emerge around the best ways to use grid-forming inverters to improve grid operations and deployments will begin to standardize. At this stage, experimentation and one-off deployments will transition to an accepted set of standard design practices and with supporting tools that will enable widespread deployment. These key steps are outlined in Figure 6.



Figure 6. Key steps for maturing grid-forming inverter technologies

Our roadmap anticipates these transitions from development to deployment and links research needs to key stages in the evolution of these systems integration requirements for grid-forming inverters, starting from microgrids, to island or other smaller weak grids, and eventually to entire interconnections. This multiyear perspective recognizes that the scale and scope of the types of power systems for which inverters will be called on to provide grid-forming services will begin modestly. Specifically, it recognizes that the dominant form of inverter control today is grid-following and that future power systems will involve a mix of inverter-based sources with both grid-following and grid-forming control. Growth over time will be paced or enabled by how well grid-forming inverters perform and what advantages they bring. This recognition, in turn, establishes a natural sequence of priorities for the research questions that must be addressed.

4.1 From Microgrids to Isolated Power Systems to Continental-Scale Power Systems

Grid-forming implementation will occur through phased implementations of grid-forming inverters, starting with smaller, more constrained microgrids and eventually moving toward larger grids (Figure 7). Even within application areas, phased implementation is likely to take place, with initial grid-forming implementation being seasonal or taking place during situational periods when additional firm sources are needed (e.g., instantaneous inverter-based generation periods or to provide voltage regulation under local, specific contingencies) before the widespread adoption of grid-forming-dominated systems. Therefore, there is a staging of implementation between different usage levels as well as stages of usage within application areas (denoted by a color gradient within an application area).

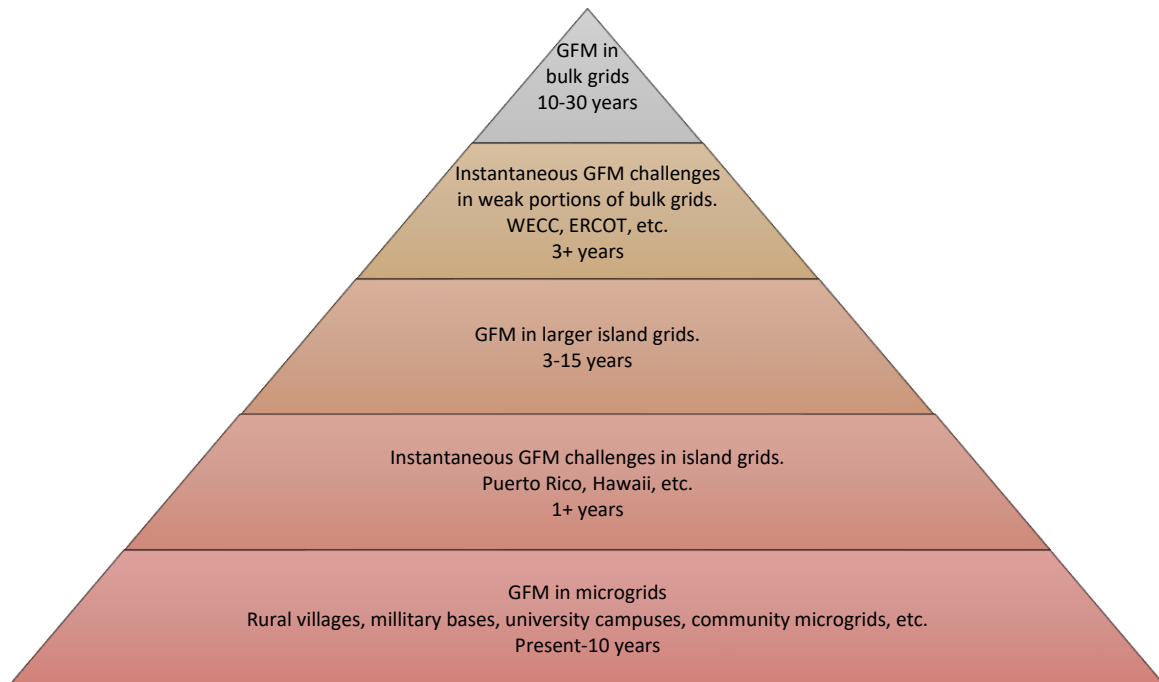

Figure 7. Incorporating grid-forming (GFM) controls into the bulk electric grid will take place gradually after key functionalities have been demonstrated and confidence has been gained by operating them in smaller microgrids and island power systems.

We are currently seeing (and will continue to see for the foreseeable future) the incorporation of grid-forming inverters in island microgrid environments. These microgrids, which are already being incorporated in a variety of areas (for example, rural villages in Alaska, university campuses, and military bases) run hybrid diesel-renewable grids with grid-forming inverters on energy storage. As the technology of grid-forming inverters matures, we will begin to see the emergence of 100% grid-forming islanded microgrids with scalable multi-inverter, multiple grid-forming-based architectures, and energy sources. Such microgrids, although small, can still provide a wealth of practical knowledge in the deployment of grid-forming inverters.

As the technology for grid-forming-based microgrids mature, grid-forming-based implementations will begin to appear in larger island grid settings (3–15 years), such as in Hawaii and the Caribbean. These grids have a larger number of interoperating sources and loads, are geographically larger, and exhibit much larger and more complex behavior compared to site-level microgrids. Additionally, although site-level islanded microgrids are primarily built at distribution-level voltages, many island grids have subtransmission-level voltages.

Validations through these comparatively smaller grids will contribute to the irreplaceable field and operational experience, along with supporting technical requirements and standards, needed to guide the large-scale implementation of grid-forming inverters within large interconnected, high-voltage transmission grids. These implementations will begin piecemeal and respond to specific operational problems created by increased inverter-based generation (relative to synchronous generation), such as the need to shore up weaker regions within the interconnection (7–20 years). Although operations in smaller grids will provide key insights about operational practices and interoperability, some fundamental research gaps still exist preventing widespread

implementation on large grids that are currently dominated by synchronous machines. A particularly challenging set of issues will involve adaptations or modifications to existing bulk power system control approaches—all of which have been based on comparatively slower acting electromechanical sources—to take advantage of the much faster acting control that is possible with inverter-based sources.

We conclude with short descriptions of two specific near-term research priorities: the review of regulatory and technical standards and the development of advanced modeling techniques. These priorities are foundational. We recommend immediate pursuit of them in parallel with and in direct support of the research outlined by our multiyear perspective.

4.2 The Need to Establish a Technical Standards Environment for Grid-Forming Inverters

Because grid-forming inverters exhibit voltage source-like behavior, they have distinct behaviors that require tailored standards. For instance, existing IEEE 1547 standards for distribution-level assets emphasize current harmonics limits, reactive power limits, and anti-islanding functions. In contrast, grid-forming units are predominantly used for voltage regulation instead of current regulation, reactive power can vary for voltage support, and grid-forming inverters natively provide uninterrupted power during islanded conditions.⁵

The following aspects should be considered in the context of ongoing efforts to modernize standards for grid-connected inverters within IEEE, the International Electrotechnical Commission, FERC, and NERC:

- Current versus voltage waveform quality: Under the existing regulatory paradigm, inverters are controlled to inject sinusoidal currents with minimal harmonic content. This aligns with prevailing practices in which harmonics demanded by nonlinear loads are provided by machines and reactive components, whereas inverters inject only 60-Hz components. If machines are displaced by grid-forming inverters, however, then inverters will need to provide these current harmonics, which some loads will require. In the future, the primary function of inverters will be to provide well-regulated system voltages for loads. The challenge is to devise a set of standards that emphasizes voltage control while recognizing the physical current-carrying limits of inverters.
- Standards for Q-V droop functions: Industry practice is largely predicated on grid-following inverters that operate at or near unity power factor. In recent years, this constraint has been relaxed with slow-acting volt-VAR controls that are intended to support system voltages. As machines are gradually displaced by grid-forming inverters, the burden of satisfying reactive power demanded by loads will shift further toward these inverters. In this future scenario, grid-forming inverters must be allowed to respond according to their autonomously executed and fast-acting Q-V droop functions to simultaneously satisfy loads and support system voltages. These Q-V droop functions for grid-forming inverters are distinct from the volt-VAR standards currently in place.

⁵ If the cumulative capacity of grid-forming inverters on a system exceeds the load, islanded operation can be sustained.

- Rethinking unintentional islanding functions: Because a grid-following inverter needs a well-defined voltage at its terminals, it can function in islanded settings only under specific conditions (e.g., inverter power must match load demand before the system is islanded). Because grid-forming inverters act like voltage sources, they generally continue operating during islanded conditions. This behavior departs from the existing regulatory framework. Future standards must reconcile the following questions:
 - How can distribution engineers de-energize systems before carrying out maintenance?
 - Should islanded subsystems within a larger grid remain energized to enhance reliability and facilitate a system black-start?

4.3 The Need to Begin Developing Appropriate Models for Existing Simulation Tools as Well as Enhanced Modeling and Simulation Tools

Modern state-of-the-art grid analysis tools have been tailored toward grids dominated by synchronous machines. A widely adopted assumption within these tools is that the synchronous speed of power systems remains relatively close to nominal during and after a transient; however, this widely adopted assumption might not be valid in systems with high penetrations of inverter-based generation because they lack synchronously connected rotor inertia. Hence, researching appropriate modeling and simulation tools that are suitable to study the transition from machine-based systems to inverter-based ones is a high priority. In fact, some independent system operators and developers require this capability immediately, highlighting the importance and urgency of appropriate modeling and simulation tools.

Another important challenge is to simulate inverter controllers as implemented in the field to accurately predict undesirable performance. This problem was highlighted during the recent Blue Cut Fire, Canyon Fire 2, and subsequent events, where disconnections of inverters were not predicted by current simulation. This problem can extend to the future incorporation of inverters with grid-forming controls; hence, appropriate models for existing transient simulation tools should be implemented.

5 Conclusion

For the next decade and beyond, the large interconnections will comprise both electromechanical and inverter-based resources. Inverter-based, grid-forming resources will be necessary for the stable operation of the bulk power grid. This article envisioned the key short- and long-term research-and-development needs for inverter-based resource grid-forming controls, protection, and modeling as part of hybrid grids. We also provided a comprehensive analysis of the challenges in integrating inverter-based resources and offer recommendations on potential technology pathways to inform the academic community, industry, and research organizations.

Additional short-term and long-term roadmapping, and detailed system performance metrics will need to be developed to support this transition to the next generation power system with inverter-based resources. Future assessment will also need to address the many areas beyond the scope of this article that more broadly correlate to long-term grid modernization efforts, for instance,

distribution system operations with grid-forming inverter controls, evolution of sensing and communications systems, economic analysis, and cybersecurity.

For Further Reading

Chandorkar, M.C., D.M. Divan, and R. Adapa. 1993. “Control of Parallel Connected Inverters in Standalone ac Supply Systems.” *IEEE Transactions on Industrial Applications* 29, no. 1 (January/February).

Institute of Electrical and Electronics Engineers (IEEE). 2018. “IEEE 1547 Standard for Interconnection and Interoperability of Distributed Energy Resources with Associated Electric Power Systems Interfaces.”

Johnson, B.B., et al. 2016. “Synthesizing Virtual Oscillators to Control Islanded Inverters.” *IEEE Transactions on Power Electronics* 31 no. 8: 6002–6015.

Lasseter, R.H. 1998. “Control of Distributed Resources.” *Proceedings of the 1998 International Conference on Bulk Power Systems Dynamics and Control IV-Restructuring*. 323–330.

Lin, Y., Eto, J.H., Johnson, B.B., Flicker, J.D., Lasseter, R.H., Villegas Pico, H.N., Seo, G.S., Pierre, B.J. and Ellis, A., 2020. *Research Roadmap on Grid-Forming Inverters* (No. NREL/TP-5D00-73476). National Renewable Energy Lab.(NREL), Golden, CO (United States).

Matevosyan, J., Badrzadeh, B., Prevost, T., Quitmann, E., Ramasubramanian, D., Urdal, H., Achilles, S., MacDowell, J., Huang, S.H., Vital, V. and O’Sullivan, J., 2019. “Grid-forming inverters: Are they the key for high renewable penetration?” *IEEE Power and Energy magazine*, 17(6), pp.89-98.

North American Electric Reliability Corporation (NERC). 2018. *Reliability Guideline: BPS-Connected Inverter-Based Resource Performance*. Atlanta, GA.

Yazdani, A., and R. Iravani. 2010. *Voltage-Sourced Converters in Power Systems: Modeling Control and Applications*. Hoboken, NJ: John Wiley & Sons, Inc.

Zhong, Q.C., 2016. “Virtual Synchronous Machines: A Unified Interface for Grid Integration.” *IEEE Power Electronics Magazine* 3 no. 4: 18–27.

Acknowledgements

This work was authored in part by the National Renewable Energy Laboratory, operated by Alliance for Sustainable Energy, LLC, for the U.S. Department of Energy (DOE) under Contract No. DE-AC36-08GO28308. Funding provided by the U.S. Department of Energy Office of Energy Efficiency and Renewable Energy Solar Energy Technologies Office. The views expressed herein do not necessarily represent the views of the DOE or the U.S. Government.

Biographies

Yashen Lin (yashen.lin@nrel.gov) is with the National Renewable Energy Laboratory, USA.

Joseph H. Eto (jheto@lbl.gov) is with the Lawrence Berkeley National Laboratory, USA.

Brian B. Johnson (brianbj@uw.edu) is with the University of Washington, USA.

Jack D. Flicker (jdflick@sandia.gov) is with the Sandia National Laboratory, USA.

Robert H. Lasseter (lasseter@engr.wisc.edu) is with the University of Wisconsin, USA.

Hugo N. Villegas Pico (hvillega@iastate.edu) is with the Iowa State University, USA.

Gab-Su Seo (Gabsu.Seo@nrel.gov) is with the National Renewable Energy Laboratory, USA.

Brian J. Pierre (bjpierr@sandia.gov) is with the Sandia National Laboratory, USA.

Abraham Ellis (aellis@sandia.gov) is with the Sandia National Laboratory, USA.

Jeremiah Miller (jeremiah.miller@ee.doe.gov) is with the U.S. Department of Energy Solar Technologies Office, USA.

Guohui Yuan (guohui.yuan@ee.doe.gov) is with the U.S. Department of Energy Solar Technologies Office, USA.