

UC Davis
Pediatrics

Title

Is it Possible to Grow B-ALL Primary Leukemia Cells In Vitro?

Permalink

<https://escholarship.org/uc/item/13w9229d>

Authors

Fujii, Quinn S

Prettyman, Jessica S

Satake, Noriko

Publication Date

2022

Data Availability

The data associated with this publication are not available for this reason: N/A



Is it Possible to Grow B-ALL Primary Leukemia Cells *In Vitro*?

Quinn S. Fujii¹, Jessica S. Prettyman², Noriko Satake²

¹School of Medicine, ²Department of Pediatrics, UC Davis

Background

B-ALL is the most common cancer in children, but B-ALL primary leukemia cells are not known to grow well *in vitro* (1,2). *In vitro* cell culture is a valuable tool used to craft therapies and run other studies without using *in vivo* models. Currently, Dr. Satake's lab has been working with B-ALL in xenograft models. Serum-free culture conditions, including those similar to hematopoietic progenitor cell media, have been used to proliferate ALL blasts previously (with FLT3, SCF, and IL3 growth factors) (3). Unfortunately, outside of co-culture with mesenchymal stem cells (MSCs), there is a "lack of suitable *in vitro* culture conditions" to culture primary B-ALL cells (2). Therefore, we will attempt to use hematopoietic stem cell (HSC) media to attempt to culture primary B-ALL cells.

Objective

Ascertain if hematopoietic stem cell (HSC) media can culture primary B-ALL cells.

Methods

Media Control Test (Figure 1)

Media 1 and 2 are different varieties of ThermoFisher's CTS™ StemPro™ HSC Expansion Medium – serum-free, xeno-free medium to culture human HSCs (proliferate CD34+ cells in bone marrow, cord blood, and peripheral blood). Similar serum-free media with growth factors has been shown to proliferate ALL blasts previously (see background, 3).

1. Mixed media 1 and 2 with growth factors (thrombopoietin - TPO, Fms-related tyrosine kinase 3 ligand - FLT3, stem cell factor - SCF, interleukin 6 - IL6, and interleukin 3 - IL3) and HSC supplement in the amounts specified by the manufacturer.
2. Plated each media with 20K and 200K previously frozen CD34+ HSCs on a 24-well plate.
3. Repeated 2 times per media
4. Counted the cells in each well on days 0, 5, 7, 8, and 12 to check growth progress.
5. Added more media with growth factors between days 7-9 as needed.

Methods (cont.)

B-ALL Leukemia Cell Proliferation (Primary Leukemia Cells (PLS) (Figure 2)

1. Used prepared media 2 (see control test step 1) to plate 20K and 200K of 6th generation xenograft B-ALL sample and CD34+ control cells on a 24-well plate.
2. Repeated for each cell type.
3. Counted the cells on each well on days 0, 2, 4, 7, 9, and 11.
4. Added more media with growth factor as needed.

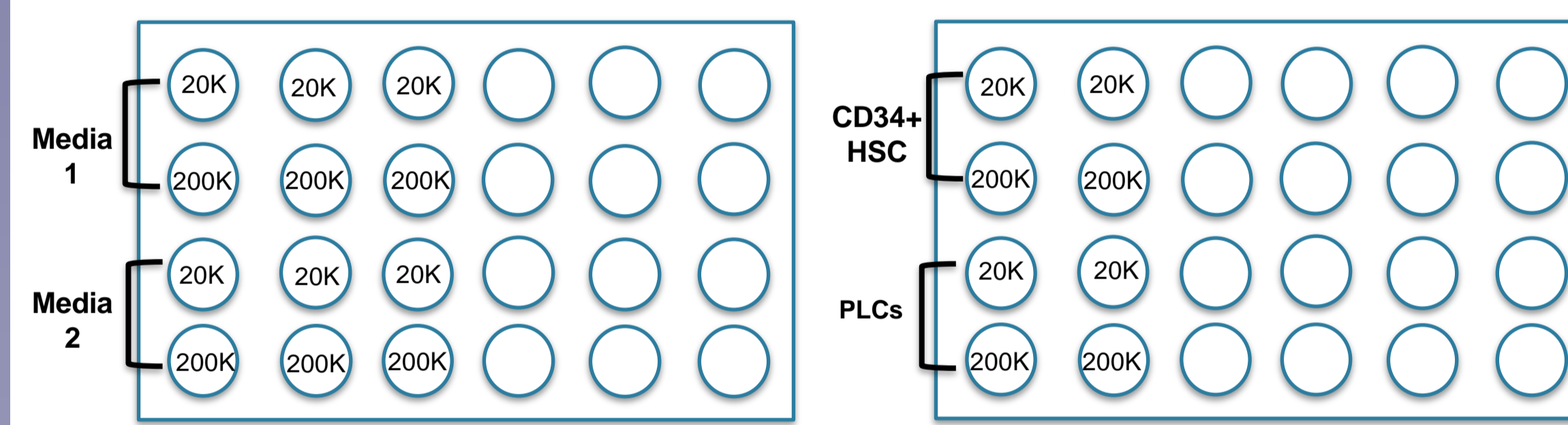

Figure 1. Media Control Test Setup with CD34+ HSCs

Figure 2. Primary Leukemia Cell Trial Setup using Media 2

Results

MEDIA 1&2 TESTS

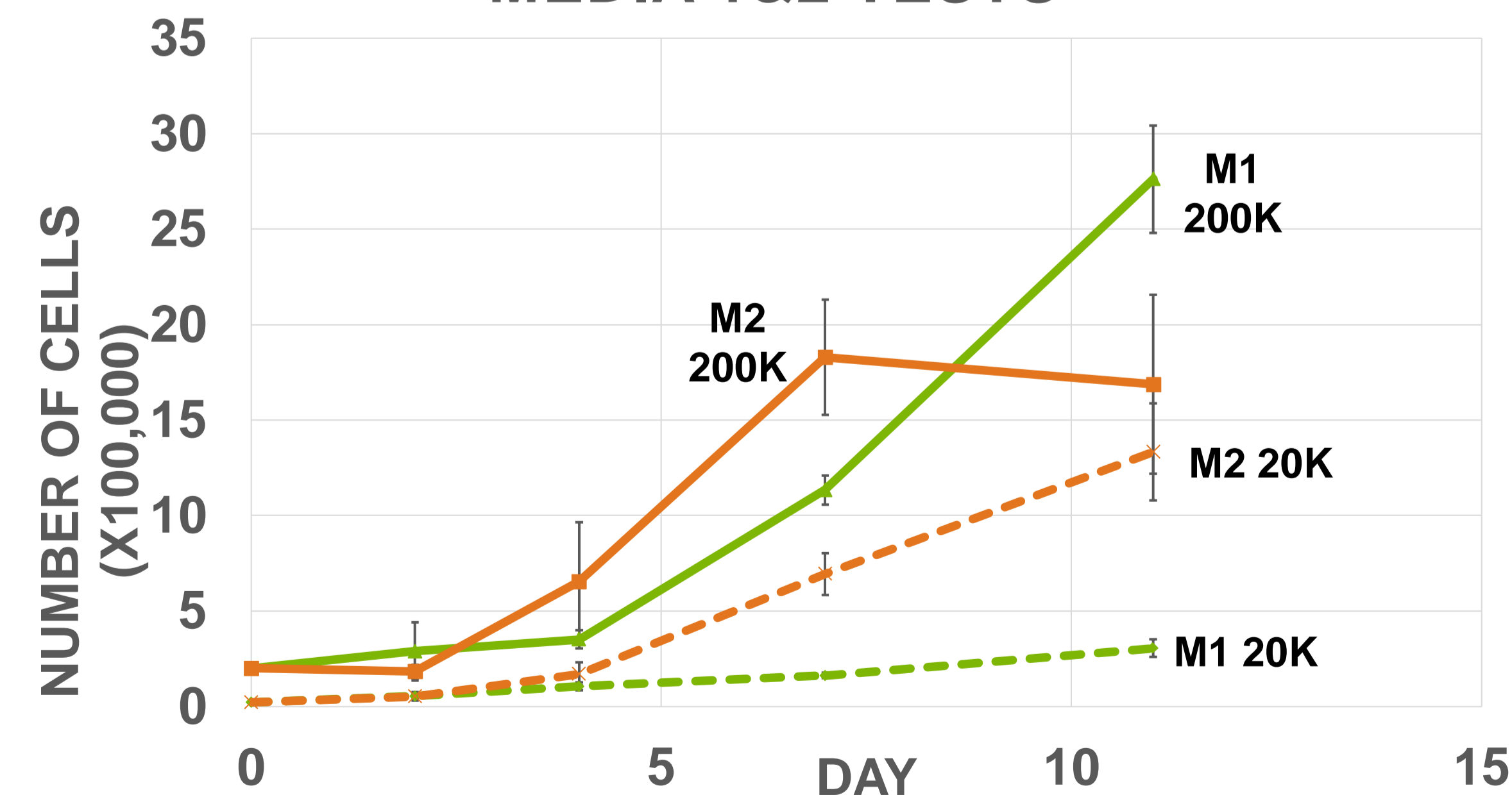

Figure 3. Media (1 and 2) Control Test Results with CD34+ HSCs

(1) Figure 3, results from media control test. Both media demonstrated CD34+ HSC proliferation. The media 2 200K cell wells show peak growth around day 7 before declining, while the other wells showed continued growth.

Results (cont.)

CD34+ VS. PLC GROWTH IN MEDIA 2

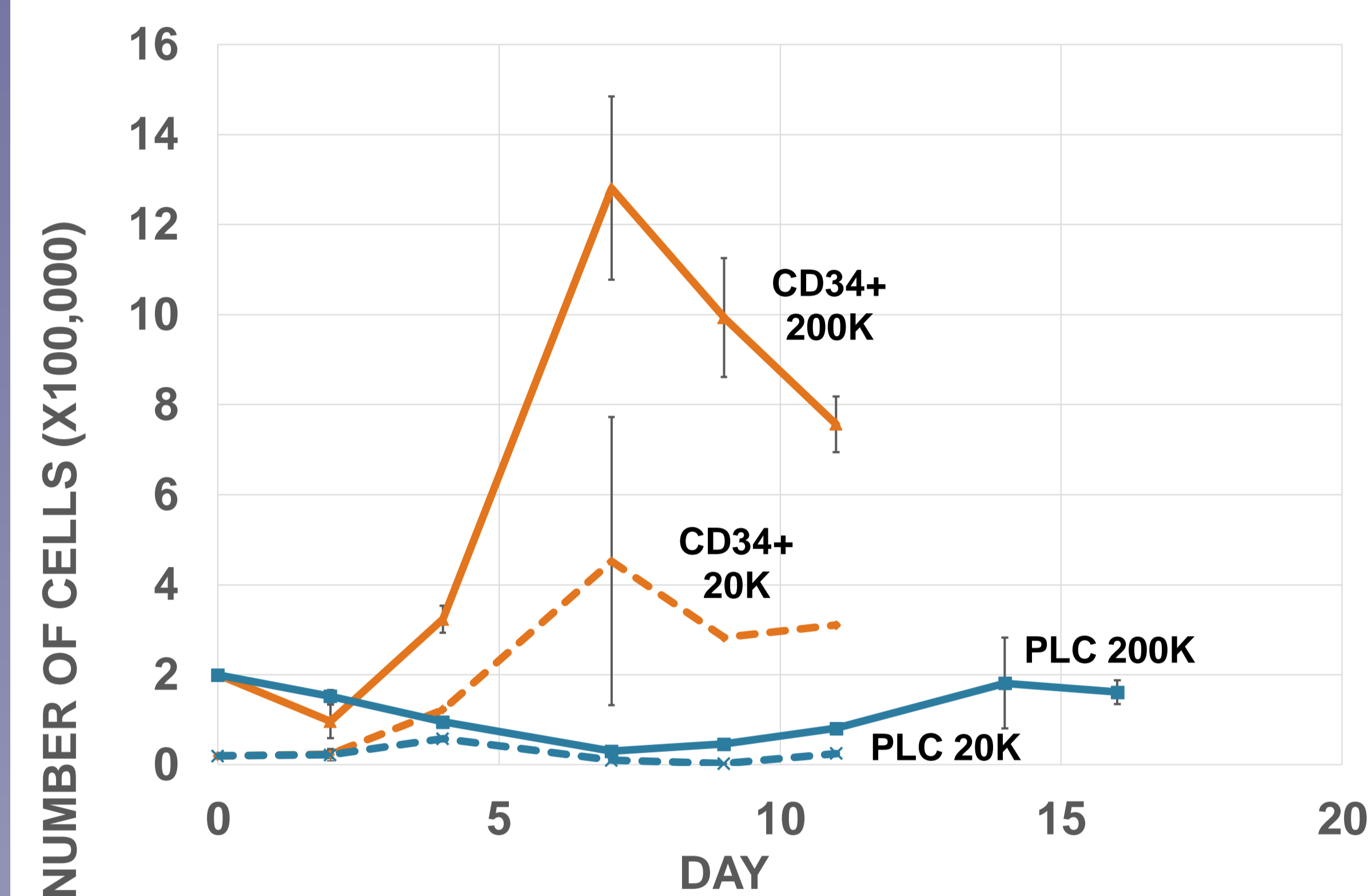

Figure 4. Primary Leukemia Cell (PLC) Proliferation Results in Media 2

(2) Figure 4, results from PLC test. As media 2 promoted a higher rate of growth in the previous trial, it was used for the initial PLC growth trial. CD34+ control HSCs grew as expected, peaking around day 7 before declining in growth. The PLC 20K experimental wells did not show significant proliferation, but the PLC 200K wells demonstrated initial decrease in cell count that began to increase after day 5.

Discussion

The media control test showed growth as expected, demonstrating that both media with the recommended growth factors are able to grow HSCs.

The late cell count increase from the 200K PLC test warrants further examination. It could be a characteristic of the primary B-ALL cells in the sample or it could be due to proliferation of a small amount of stem cells (such as leukemia stem cells or HSCs) in the sample. We will not know if this is a common growth pattern or what it represents without further testing.

Summary

Media 1 and 2 work as intended to grow HSCs and have an unclear potential to grow B-ALL PLCs.

Limitations/Next Steps

Limitations

- 1) Many of the cells were noted to be granular and dead-appearing (primarily in the PLC 20K wells), which affected the cell count. This can be improved through further trials with consistent protocols.
- 2) The sample size (N) is too small to make any conclusions from this study. Further trials are required.

Next Steps

- 1) Continue trials with primary B-ALL in media 2.
- 2) Repeat with media 1.
- 3) If those results are positive, attempt to ascertain if the media is culturing stem cells via flow cytometry for known stem cell markers (CD34+)
- 4) Attempt the study of quiescent leukemia stem cells (LSCs) as identified previously by Dr. Satake (manuscript pending publication).

Acknowledgements/References

Media 1, 2 and growth factors provided by ThermoFisher Scientific.

1. Hunger SP, Mullighan CG. Acute Lymphoblastic Leukemia in Children. *N Engl J Med.* 2015 Oct 15;373(16):1541-52. doi: 10.1056/NEJMra1400972. PMID: 26465987.
2. Pal, D., Blair, H., Elder, A. et al. Long-term *in vitro* maintenance of clonal abundance and leukaemia-initiating potential in acute lymphoblastic leukaemia. *Leukemia* 30, 1691–1700 (2016). <https://doi.org/10.1038/leu.2016.79>
3. Bruserud Ø, Glenjen N, Rynningen A, Ulvestad E. *In vitro* culture of human acute lymphoblastic leukemia (ALL) cells in serum-free media; a comparison of native ALL blasts, ALL cell lines and virus-transformed B cell lines. *Leuk Res.* 2003 May;27(5):455-64. doi: 10.1016/s0145-2126(02)00227-8. PMID: 12620297.