

# UC Merced

## Biogeographia - The Journal of Integrative Biogeography

### Title

Areas of endemism of Jamaica: inferences from Parsimony Analysis of Endemism based on amphibian and reptile distributions

### Permalink

<https://escholarship.org/uc/item/1842t3m0>

### Journal

Biogeographia - The Journal of Integrative Biogeography, 36(0)

### ISSN

1594-7629

### Authors

Stanely, Louis  
Murray, Christopher M  
Murray, Jon J  
[et al.](#)

### Publication Date

2021

### DOI

10.21426/B636052803

### Supplemental Material

<https://escholarship.org/uc/item/1842t3m0#supplemental>

### Copyright Information

Copyright 2021 by the author(s). This work is made available under the terms of a Creative Commons Attribution License, available at <https://creativecommons.org/licenses/by/4.0/>

Peer reviewed

# Areas of endemism of Jamaica: inferences from Parsimony Analysis of Endemism based on amphibian and reptile distributions

LOUIS STANLEY<sup>1</sup>, CHRISTOPHER M. MURRAY<sup>1</sup>, JON J. MURRAY<sup>2</sup>,  
BRIAN I. CROTHER<sup>\*1</sup>

<sup>1</sup>*Department of Biological Sciences, Southeastern Louisiana University, Hammond, Louisiana, 70402 (USA)*

<sup>2</sup>*Roxbury, Connecticut, 06783 (USA)*

*\* corresponding author, email: bcrother@selu.edu*

Keywords: Biogeography, Extinction, Dispersal, Ambiguous Apomorphies, Herpetofauna.

## SUMMARY

Islands represent interesting biogeographic features often defined by unique and dynamic geological and biological components. Such systems serve as examples of the basic fundamental units of biogeographical analyses: areas of endemism. The island of Jamaica is recognized as possessing a unique biota with a large number of herpetofauna species persisting only within the island. Further, Jamaica exhibits a dynamic geologic history characterized by an easterly migration and repeated inundation, resulting in a contemporary biota formed through dispersal. Here, we infer areas of endemism across Jamaica based on 57 amphibian and reptile distributions using Parsimony Analysis and Endemism (PAE). We recover 19 areas of endemism concentrated in two regions: The Blue Mountains region diagnosed by 8 taxa and the west/central limestone plateau region including Cockpit Country and the western Dolphin Head region, diagnosed by 9 taxa. Further discussion on the utility of ambiguous syntaxa in diagnosing extinction, dispersal and ecological patterns as they pertain to biogeographic units is provided.

## INTRODUCTION

As isolated fragments of terrain scattered throughout the vast, expansive hydrosphere of this planet, many islands have long presented an air of allure and intrigue, encompassing an enigmatic realm filled with their own mosaic of dynamic and interactive life forms. Their relative geographic insulation and their natural

constraints against dispersal and emigration make them ideal natural laboratories, and many have facilitated numerous landmark trials and experiments throughout history, delving into the underlying mechanisms behind geological and biological processes alike (Whittaker et al. 2017). Whether oceanic or continental in origin, polar or tropical in climate, each tends to hold its own cache of iconic defining features, and

many harbor a treasury of floras and faunas found nowhere else on Earth (Whittaker et al. 2007). The uniqueness and geographical isolation of these species bolsters their status not only as special individuals in and of themselves, but as characterizing features of the unduplicated realms they inhabit (e.g. Carlquist 1974, Kueffer et al. 2014). The lengthy chronology of fabled journeys and exploits revolving around these life forms and the mysteries surrounding them and their domain outlines, and sometimes obfuscates, the substantially longer and more confounding account of the geological processes that molded these territories into their current forms. For this reason, the geographical features formed from them are inevitably tied to these species' distributions, and together, they characterize all or part of these ranges as unique individuals themselves. Defined by both geographical and biological components shared with no other location, these areas form the basic fundamental units of many forms of biogeographical analysis: areas of endemism (Crisci et al. 2003, Parenti and Ebach 2009, Crother and Murray 2011). Discovery of these areas of endemism are therefore essential in these analyses (Parenti and Ebach 2009, Fattorini 2017), and islands often make ideal testing grounds not only for diagnosing them, but in tying together the biogeographical, ecological, and anthropogenic factors that both define them and relate them to other areas (Walter 2004, Fattorini and Fowels 2005, Fattorini 2007a).

## Jamaica

The island of Jamaica is recognized as possessing a unique biota (e.g. Farr 1984, Buskirk 1985, 1992), including its herpetofauna (Lynn and Grant 1940, Crombie 1999). Lynn (1940: 10) was matter of fact: "Examination of the list of species of Jamaican amphibians reveals that all (except the introduced forms) are peculiar to the island." In a recent analysis, Morrone (2001) formally diagnosed Jamaica as

an area of endemism based on arthropods, actinopterygians, and reptiles. Plants exhibit the same patterns of high numbers of faunal endemics, with Jamaica having over 2500 species of flowering plants, of which about 30% are endemics (Santiago-Valentin and Olmstead 2004).

Hypotheses of the origins of these endemics differ, depending if the biotas were pre- or post-inundation. Various, Jamaica has been cited to have been submerged from as early as the upper middle Eocene to as late as the early Miocene (Meyerhoff and Krieg 1977, Burke et al. 1980, Lewis and Draper 1990, Buskirk 1992). Pre-inundated Jamaica apparently possessed biotas from its Central American connection with the Chortis Block and/or southern Mexico/Yucatan (e.g. Crother and Guyer 1996, Domning et al. 1997, Pregill 1999, Graham 2003, MacPhee 2005, Valls Alvarez 2009). It is worth noting that inundation may have happened twice, first at the K-T boundary caused by an exogenous bolide (Hedges et al. 1992, Hedges 1996, but see Crother and Guyer 1996), and second in the later Tertiary as noted above. Post-inundation, the island's biotas originated via dispersal and subsequently have eclectic and diverse origins such as southern Hispaniola, Hispaniola, northern Lesser Antilles, Cuba, Puerto Rico, Central America, Mexico, and the Bahamas (Crother and Guyer 1996, Peck 1999, Lavin and Matos 2008, Matos-Maraví et al. 2014, Uit de Weerd et al. 2016, Weaver et al. 2016). While much has been done to understand the uniqueness and origins of the Jamaican biotas, interestingly, there has yet to be an evaluation of the areas of endemism across Jamaica. The goal of the present study is to infer areas of endemism across Jamaica based on amphibian and reptile distributions. Regarding such a study, Schwartz and Fowler (1973:128) gave a warning: "The seventeen species of native Jamaican frogs show a series of distributional patterns, which, when correlated with the island's geography and with data from other vertebrate groups, suggest that *the faunal*

*history of Jamaica has been far from simple (emphasis ours)."*

Modern Jamaica is situated approximately 200 km southeast of Cuba and at the same distance from Haiti's Tiburon Peninsula. With an expanse covering just over 11,000 Km<sup>2</sup>, it is the smallest of the Greater Antilles next to the Greater Puerto Rican Bank. It shares no seaboard or bank with any other landmass, and the deep waters surrounding it make a formidable barrier to benthic or subterranean dispersal (Crombie 1999). Its primary landmass is largely dominated by the massive limestone platform buttressed by the upshoot of igneous and metamorphic rocks which form its core. This central plateau ranges anywhere from 610-760 m above sea level. Slightly beneath is the Southern Alluvial Plain. Among both expansive landscapes, numerous series of ridges and uplifts arise, including the Santa Cruz Mountains, Dry Harbor, Portland Ridge, and Hellshire Hills. The famous Blue and John Crow Mountains, located on the eastern peninsula, are densely forested and high-rising, with the Blue Mountain Peak forming the highest elevation point on the island, at 2,256 m. They were formed from an uplift resulting from the jarring impact of a shale mass colliding with the limestone platform sometime during the Pliocene Period (Buskirk 1985). Three additional islets are also official national territories. Cabarita Island is located off the northern coast near St. Mary. Pedro and Morant Cays, located to the far south and southeast, respectively, are separated from the bank.

The Jamaican fauna includes approximately 60 species of reptiles and amphibians with 56 species considered island endemics (Crombie 1999 listed 58 endemics). This large diversity on the relatively small island covers the entirety of Jamaica geographically, making these groups ideal for diagnosing areas of endemism. Modern physiography along with geological history can be used as a basis to develop hypotheses

regarding areas of endemism, potentially in conjunction with ecological parameters. Here, we seek to test area of endemism hypotheses based on an intriguing observation made by Levy and Koenig (2009: 262): "Due to the island's geologic history of volcanic extrusion, subsidence, and tectonic uplift, the Blue and John Crow Mountains, Cockpit Country, and Dolphin Head are recognized as three "hotspots" of adaptive radiation and endemism".

This observation hypothesizes three areas of endemism in Jamaica based on modern geography and historical (geological) data; a mountainous eastern region (Blue and John Crow Mountains), a hilly central region (Cockpit Country), and a mountainous western region (Dolphin Head Mountains).

The present study seeks to test the existence of these and/or other areas of endemism (AEs) in Jamaica on the basis of amphibian and reptile distributions. We employ the Parsimony Analysis of Endemism (PAE) approach following Rosen (1988) and as modified by Morrone (2014), Crother and Murray (2013), and Murray and Crother (2018). Our interpretation of the PAE results follows our ontological conclusions on the nature of areas of endemism (Crother and Murray 2011). While many criticisms (see Murray and Crother 2018 for an exhaustive rebuttal to these) have been leveled at PAE, we agree with Fattorini (2017: 56) that "these critiques do not disprove its use to identify areas of endemism."

## MATERIALS AND METHODS

A total of 57 species of reptiles and amphibians residing within Jamaica (including its offshore islets) were selected for analysis. They were numerically labelled, from 1-57 (Table 1). The species distributions are from Schwartz and Henderson (1991) and from the database of CaribHerp (Hedges 2018, [www.caribherp.org](http://www.caribherp.org)), and include all species level taxa labeled as endemic on the website.

Table 1. Species List. Numbers correspond to those in the PAE analyses.

1. Jamaican Giant Anole *Norops garmani* (Stejneger, 1899)
2. Jamaican Turquoise Anole *Norops grahami* (Gray, 1845)
3. Stripe-footed Anole *Norops lineatopus* (Gray, 1840)
4. Jamaican Opal-bellied Anole *Norops opalinus* (Gosse, 1850)
5. Blue Mountains Anole *Norops reconditus* (Underwood & Williams, 1959)
6. Cuban Brown Anole *Norops sagrei* (Cocteau in Duméril & Bibron, 1837)
7. Jamaican Twig Anole *Norops valencienni* (Duméril & Bibron, 1837)
8. Jamaican Croaking Gecko *Aristelliger praesignis* (Hallowell, 1857)
9. Limestone Forest Galliwasp *Celestus barbouri* Grant, 1940
10. Jamaican Galliwasp *Celestus cruscus* (Garman, 1888)
11. Blue-tailed Galliwasp *Celestus duquesneyi* Grant, 1940
12. Bromeliad Galliwasp *Celestus fowleri* (Schwartz, 1971)
13. Red-spotted Galliwasp *Celestus hewardii* Gray, 1845
14. Small-eyed Galliwasp *Celestus microlepharis* (Underwood, 1959)
15. Portland Coast Galliwasp *Celestus molesworthi* Grant, 1940
16. Jamaican Giant Galliwasp *Celestus occiduus* (Shaw, 1802)
17. Jamaican Boa *Chilabothrus subflavus* (Stejneger, 1901)
18. Jamaican Iguana *Cyclura collie* Gray, 1845
19. Jamaican Peak Frog *Eleutherodactylus alticola* Lynn, 1937
20. Jamaican Rumpspot Frog *Eleutherodactylus andrewsi* Lynn, 1937
21. Portland Ridge Frog *Eleutherodactylus cavernicola* Lynn, 1954
22. Jamaican Rockfrog *Eleutherodactylus cundalli* Dunn, 1926
23. Jamaican Ear-spotted Frog *Eleutherodactylus fuscus* Lynn & Dent, 1942
24. Blue Mountain Rockfrog *Eleutherodactylus glaucoreius* Schwartz & Fowler, 1973
25. Jamaican Forest Frog *Eleutherodactylus gossei* Dunn, 1926
26. Jamaican Pallid Frog *Eleutherodactylus grabhami* Dunn, 1926
27. Cockpit Frog *Eleutherodactylus griphus* Crombie, 1986
28. Jamaican Bromeliad Frog *Eleutherodactylus jamaicensis* Barbour, 1910
29. Rock Pocket Frog *Eleutherodactylus junori* Dunn, 1926
30. Jamaican Masked Frog *Eleutherodactylus luteolus* (Gosse, 1851)
31. Jamaican Red-eyed Frog *Eleutherodactylus nubicola* Dunn, 1926
32. Jamaican Streamfrog *Eleutherodactylus orcutti* Dunn, 1928
33. Jamaican Yellow-bellied Frog *Eleutherodactylus pantoni* Dunn, 1926
34. John Crow Yellow-bellied Frog *Eleutherodactylus pentasyringos* Schwartz & Fowler, 1973
35. Leaf Mimic Frog *Eleutherodactylus sisypodemus* Crombie, 1977
36. Jamaican Giant Racer *Hypsirhynchus ater* (Gosse, 1851)
37. Jamaican Red Racer *Hypsirhynchus callilaemus* (Gosse, 1851)
38. Jamaican Black Racer *Hypsirhynchus funereus* (Cope, 1863)
39. Jamaican Long-tailed Racer *Hypsirhynchus polylepis* (Buden, 1966)
40. Jamaican Snoring Treefrog *Osteopilus crucialis* (Harlan, 1826)
41. Jamaican Yellow Treefrog *Osteopilus marianae* (Dunn, 1926)
42. Jamaican Laughing Treefrog *Osteopilus ocellatus* (Linnaeus, 1758)
43. Jamaican Green Treefrog *Osteopilus wilderi* (Dunn, 1925)
44. Jamaican Groundlizard *Pholidoscelis dorsalis* (Gray, 1838)
45. West Caribbean Ocellated Geckolet *Sphaerodactylus argus* Gosse, 1850
46. Jamaican Tail-spotted Geckolet *Sphaerodactylus dacnicolor* Barbour, 1910
47. Jamaican Forest Geckolet *Sphaerodactylus goniorhynchus* Cope, 1895
48. Jamaican Sharp-nosed Geckolet *Sphaerodactylus oxyrhinus* Gosse, 1850
49. Southern Jamaica Banded Geckolet *Sphaerodactylus parkeri* (Grant, 1939)
50. Northern Jamaica Banded Geckolet *Sphaerodactylus richardsoni* Gray, 1845
51. Cockpit Eye-spotted Geckolet *Sphaerodactylus semasiops* Thomas, 1975
52. Jamaican Skink *Spondylurus fulgidus* (Cope, 1862)
53. Jamaican Slider *Trachemys terrapen* (Lacépède, 1788)
54. Jamaican Brown Trope *Tropidophis jamaicensis* Stull, 1928
55. Jamaican Eye-spotted Trope *Tropidophis stejnegeri* Grant, 1940
56. Portland Ridge Trope *Tropidophis stullae* Grant, 1940
57. Jamaican Blindsnake *Typhlops jamaicensis* Shaw, 1802

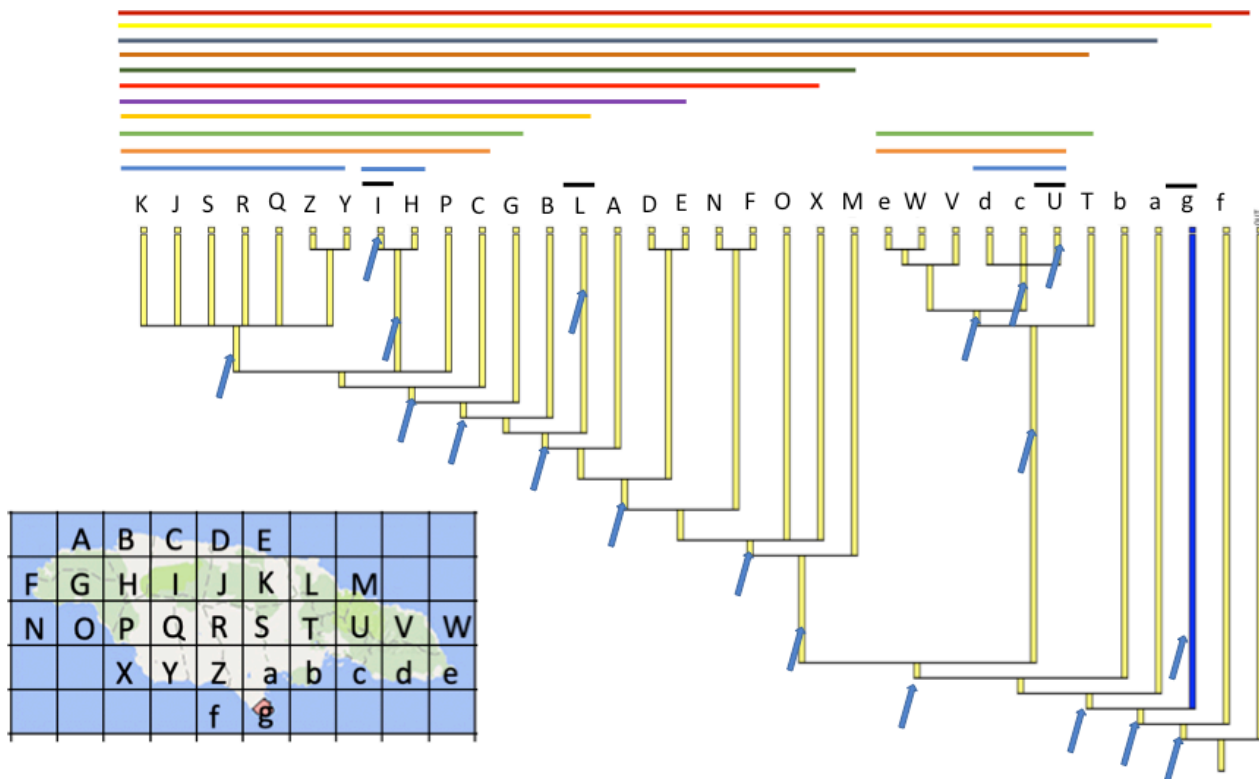

Figure 1. The strict consensus tree inferred from the analysis. The arrows point to diagnosed areas of endemism. The bars above the tree show the interested nature of the areas of endemism. The example of grid used to determine quadrats shows the distribution of *Tropidophis stullae* in quadrate g.

The list includes 35 squamates, 21 anurans, and 1 testudine. Excluded from the analysis were all human introduced species (*Norops sagrei* (Cocteau in Duméril & Bibron, 1837) was included because it is uncertain whether its introduction was human-mediated; Henderson and Powell 2009), all sea turtles, and the one crocodylian. The Jamaican Collared Geckolet (*Sphaerodactylus gilvitorques* Cope, 1862) and the Jamaican Giant Gecko (*Tarentola albertschwartzi* Sprackland & Swinney, 1998), also endemic to Jamaica, were excluded due to deficient data and no available distribution range.

A grid with completely congruent squares (approximately 0.5° edges) was superimposed over a map of Jamaica, dividing the main islands and its islets into 33 arbitrary

geographic sectors, labeled A-Z, and a-g (Fig. 1). The terrestrial fraction in some of the coastal sectors was very marginal, a detail that must be factored in when diagnosing endemism. The same grid map was replicated for every species, with the distribution range of each species displayed on the map. A presence/absence (0=absent, 1=present) data matrix (available as supplementary information) was constructed based on these distribution ranges and included an all 0 outgroup.

The analysis and interpretation followed the PAE method (Parsimony Analysis of Endemism), following Rosen (1988), Crother and Murray (2013), Morrone (2014), and Murray and Crother (2018). The data were analyzed within a parsimony framework using

PAUP\* (Swofford 2002). The most parsimonious hypothesis was inferred with random stepwise addition (used random starting trees) with 500 iterations and TBR branch swapping.

Species distributions (i.e. character states) were optimized using either accelerated

or delayed transformation (ACCTRAN and DELTRAN, respectively; Geraads 1998; Crother and Murray 2013). Area of endemism diagnosis was given for each cell based on the criteria of the distribution of a unique species, or a unique combination of species (Crother and Murray 2011, 2013).

Table 2. Diagnosed Areas of Endemism. Letter refers to grid area and the numbers refer to the species that diagnose that area. The \* denotes ambiguous apomorphies and are described below.

- 1) I: 12, 35
- 2) L: 14
- 3) U: 19, 31
- 4) g: 21, 56
- 5) HI: 27
- 6) Ucd: 5
- 7) UcdVWe: 20\*, 32\*, 34, 46\*
- 8) TUcdVWe: 24
- 9) JKRSQ: 29\*
- 10) CHIKRSQYZP: 9\*, 41\*
- 11) CHIKRSQYZPG: 26\*
- 12) BCHIKRSQYZPGL: 40\*
- 13) ABCHIKRSQYZPGLDE: 13\*
- 14) ABCHIKRSQYZPGLDEFNOX: 22
- 15) ABCHIKRSQYZPGLDEFNOXM: 6\*
- 16) ABCHIKRSQYZPGLDEFNOXMTUcdVWe: 43
- 17) ABCHIKRSQYZPGLDEFNOXMTUcdVWeba: 25\*
- 18) ABCHIKRSQYZPGLDEFNOXMTUcdVWebag: 1
- 19) ABCHIKRSQYZPGLDEFNOXMTUcdVWebagf: 2, 3, 4, 7, 10\*, 17, 36, 45, 53\*

- \*6 diagnosed A-M, with “a” as unique
- \*9, 41 diagnosed C-P, with d as unique and a loss in sister grids Y-Z
- \*10 diagnosed A-F, with a loss in M
- \*13 diagnosed A-E, with losses in A and S
- \*20 diagnosed U-e, with a loss in e
- \*25 diagnosed A-a, with a loss in sister grids F-N
- \*26 diagnosed C-G, with D unique
- \*29 diagnosed J-Q, with I unique and a loss in sister grids Y-Z
- \*32 diagnosed U-e, with a loss in sister grids W-e
- \*40 diagnosed B-L, with T unique and losses in B, C
- \*41 diagnosed C-P, with D unique and a loss in sister grids Y-Z
- \*46 diagnosed U-e, with a loss in sister grids U-c
- \*53 diagnosed A-f, with losses in d and sister grids W-e

## RESULTS

The analysis resulted in 44 equally most parsimonious trees (MPTs), each with a tree length of 149 steps, CI (consistency index) = 0.32 (excluding uninformative characters) and RI (retention index) = 0.7. A strict consensus

tree was constructed from the MPTs (Fig. 1). A total of 19 AEs were diagnosed. Fourteen taxa (refer to Table 1 for species; 1, 2, 3, 4, 5, 7, 17, 22, 24, 27, 34, 36, 42, 45) appeared on the tree as unambiguous synapomorphies (CI = 1.00) that diagnosed multigrad AEs. Six taxa (12, 14, 19, 21, 31, 35, 56) were inferred as

autapomorphies and diagnosed unique single grid areas of endemism. These unambiguous apomorphies (species) diagnosed 12 AEs (Table 2), from the size of the entire island (e.g. *Norops garmani* (Stejneger, 1899), *N. opalinus* (Gosse, 1850)), to small geographic areas such as the southern peninsula Portland Ridge tipped by Portland Point (*Tropidophis stullae* Grant, 1940, *Eleutherodactylus cavernicola* Lynn, 1954).

Ambiguous apomorphies (homoplastic distributions; see Murray and Crother 2018 for their use in PAE) diagnosed seven additional AEs. However, assumptions of dispersal/extinction are required. Species 6, 9, 15, 16, 18, 26, 30, 33, 37, 46 all exhibit contiguous distributions but the areas are unrelated on the tree. Species 10, 13, 20, 25, 32, 39, 47, 48, 50, 51, 53, 55 are also contiguous but the area clades on the tree are paraphyletic because of the absence of the species in a grid clade. Species 39, 47, 50, 54, and 57 have disjunct distributions with the absence in certain grids yielding the same paraphyly problem. Species 28 and 43 exhibit similar east-west distributions and diagnose two unrelated clades. Species 23, 41, and 42 have contiguous west-central distributions that exhibit both unrelated areas and paraphyletic clades, with regard to presence. Species 11 has two disjunct localities, which are unrelated, and a couple species have scattered, spotty distributions (16, 44).

These ambiguous apomorphies diagnosed 14 AEs, with seven of those unique, therefore not diagnosed by unambiguous apomorphies. In total, 19 AEs were diagnosed within Jamaica (Fig. 1).

## DISCUSSION

The geologic history of Jamaica reveals a landmass that persists as emergent no later than the early Miocene (ca. 20 mya) and is characterized by a rapid eastward migration given calculated rates of Caribbean Plate

movement (Buskirk 1985). Prominent and contemporary strike-slip faulting has culminated in a topographically dynamic landscape across a relatively small emergent landmass (Buskirk 1985). Biotic inhabitants of Jamaica, given its recent emergence, are predominantly a result of dispersal from older Greater Antillean sources (Crother and Guyer 1996). Nineteen (19) AEs were diagnosed in the present study using native amphibian and reptile species. The nineteen AEs predominantly nest in two general regions within the island; The Blue Mountains region [T((Ucd)(VWe)), (Ucd)(VWe), UCd, and U] diagnosed by 8 taxa and the west/central limestone plateau region [B(C((HI)(JKRSQ(YZ)))P)G)L, C((HI)(JKRSQ(YZ)))P, (JKRSQ(YZ)), G, I, (HI)] including Cockpit Country (HI) and the western Dolphin Head region (G), diagnosed by 9 taxa. Syntaxa from the lizard clades *Norops* and *Sphaerodactylus*, and frog clade *Eleutherodactylus*, predominantly diagnose these areas of endemism.

Murray and Crother (2018) introduced an exercise in the consideration of suboptimal species distributions (homoplastic species in this case) as informative regarding the diagnosis of areas of endemism. Their analogy used the presence of limbs (a homoplastic character via reversals or convergence on limblessness) to diagnose Tetrapoda, a parallel to ambiguous apomorphic taxa in PAE failing to provide unambiguous support for an area of endemism as a result of local extinction or dispersal to a peripheral quadrat. In Jamaica, 30 taxa fit this pattern. 17 taxa are absent from a quadrat (extinction) that would otherwise provide unambiguous support for an area of endemism, and 13 taxa are present in a peripheral quadrat outside of a diagnosed area of endemism (dispersal).

One lesson from this study is that looking at single distributions alone, without the PAE phylogenetic framework, would lead one to misinterpret the diagnosis of an AE and apparent dispersal/extinction events. For



example, taxon 26, the Jamaican Pallid Frog (*Eleutherodactylus grabhami* Dunn, 1926) has a continuous distribution across west/west-central Jamaica and based on the distribution

alone one could not predict an apparent dispersal event with the PAE tree (Fig. 2). With the phylogeny framework, quadrat D is unrelated to AE A-G.

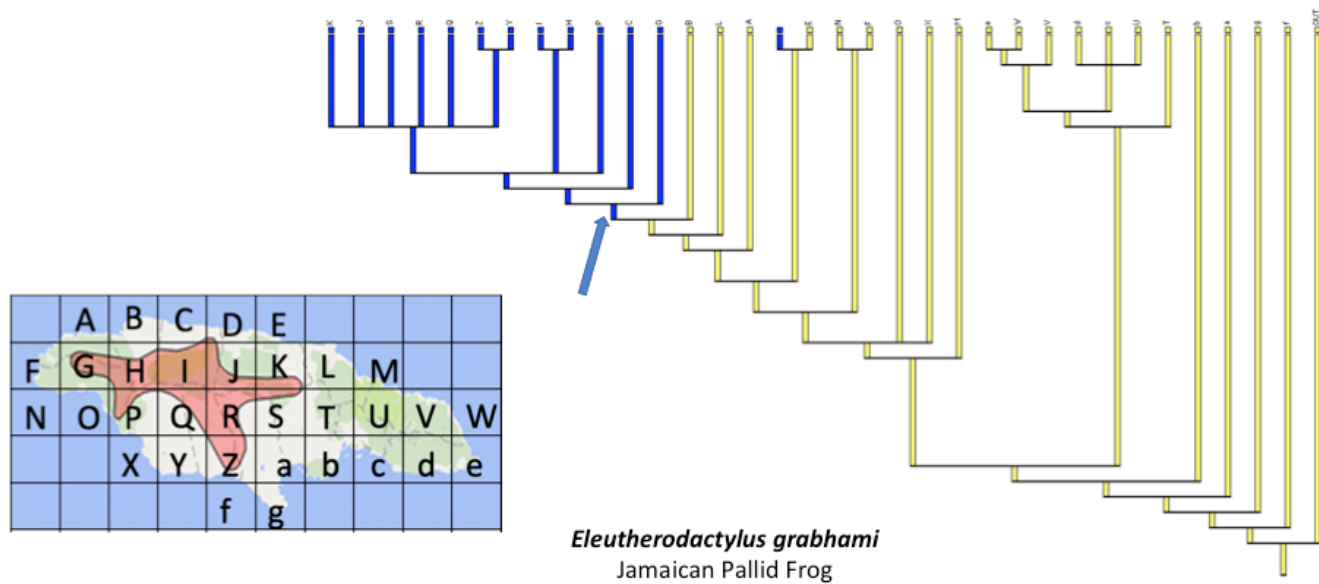

Figure 2. Distribution map and presence/absence states of *Eleutherodactylus grabhami* optimized on the PAE tree. The example illustrates the inference of dispersal to quadrat D. The arrow shows the clade diagnosed as an area of endemism.

A similar, but more obvious example is with taxon 10, the Jamaican Galliwasp (*Celestus cruscus* (Garman, 1888)) (Fig. 3). This species has a continuous widespread distribution across the island but is absent from a single grid (M). Looking at the distribution alone one may hypothesize that the species simply never reached that area of the island. However, when combining the distribution with the tree, quadrat M is in the middle of the PAE tree, rendering the island wide AE paraphyletic, and indicates to us an extinction event.

The Jamaican Forest Geckolet (*Sphaerodactylus dacnicolor* Barbour, 1910) provides an interesting example regarding the interpretation of hypotheses of extinction/dispersal (Fig. 4). The delayed

transformation (DELTRAN) of its specific cladogram indicates its appearance [46(1)] in quadrats V, W, e, and d, and its absence from Quadrats U and c. On the accelerated transformation (ACCTAN) diagram, the species is shown to appear on the collective clade [UcdVWe] - [46(1)] and then disappear from clade [Uc] - [46(0)]. Depending upon the transformation, the species can be interpreted as having appeared on the collective clade consisting of all six quadrats [UcdVWe] and then went extinct from clade [Uc] - a unique extinction event (ACCTAN) - or as having first appeared within clade [VWe] and subsequently appeared in quadrat d - a unique dispersal event (DELTRAN).

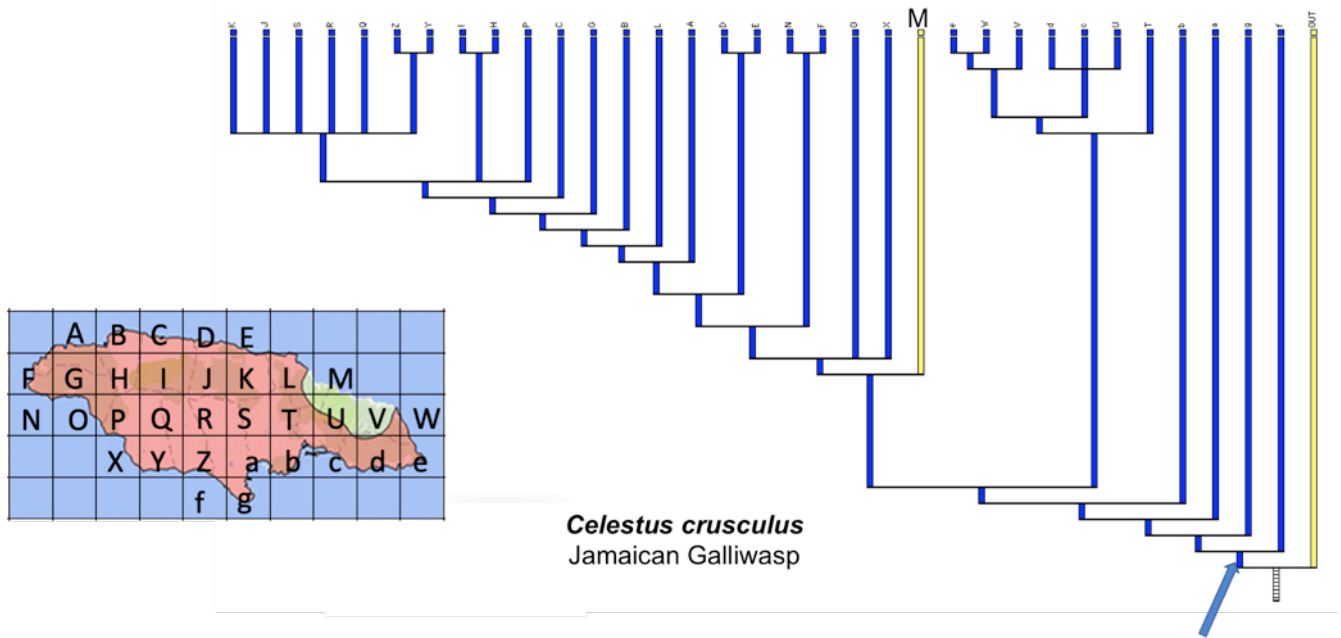

Figure 3. Distribution map and presence/absence states of *Celestus cruscus* optimized on the PAE tree. The example illustrates the inference of extinction in quadrat M. The arrow shows the clade diagnosed as an area of endemism.

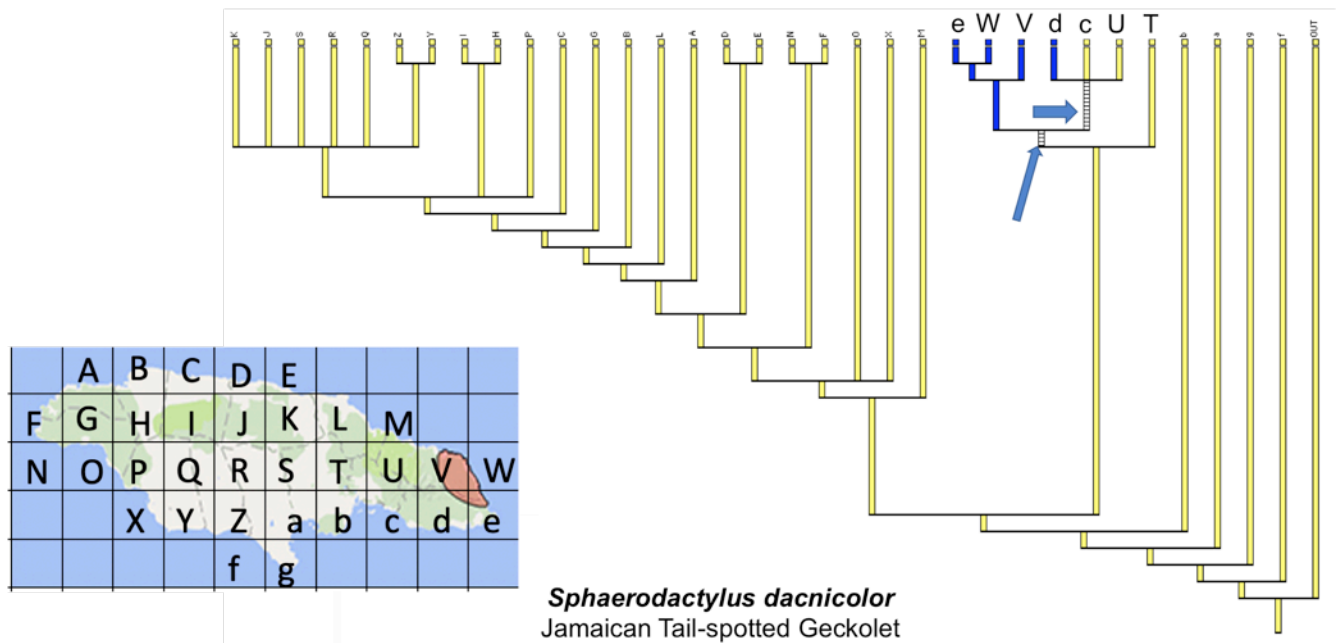

Figure 4. Distribution map and presence/absence states of *Sphaerodactylus dacnicolor* optimized on the PAE tree. The example illustrates how optimization method affects the inference of extinction or dispersal. The arrow at node UcdVWe is the diagnosed area of endemism with accelerated transformation and infers extinction in quadrats cU. The arrow at node VdWe is the diagnosed area of endemism with delayed transformation and infers dispersal to quadrat d.

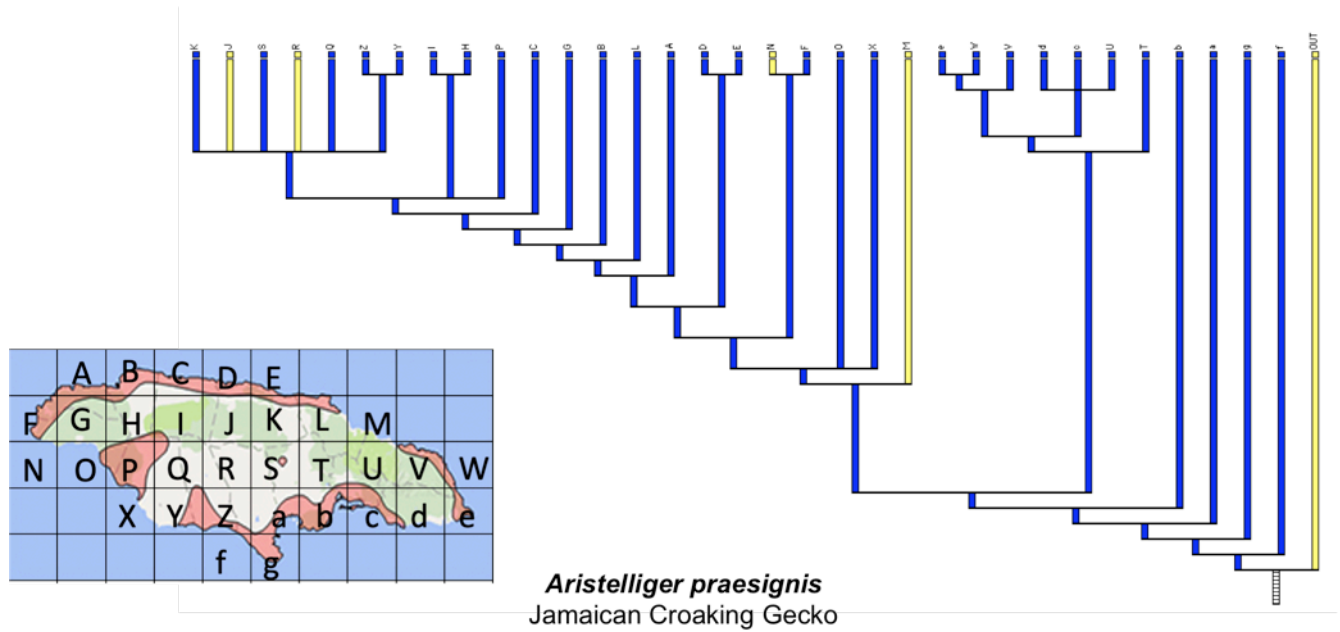

Figure 5. Distribution map and presence/absence states of *Aristelliger praesignis* optimized on the PAE tree. The example illustrates a taxon whose distributional patterns appear ecologically driven and do not contribute to the diagnosis of areas of endemism.

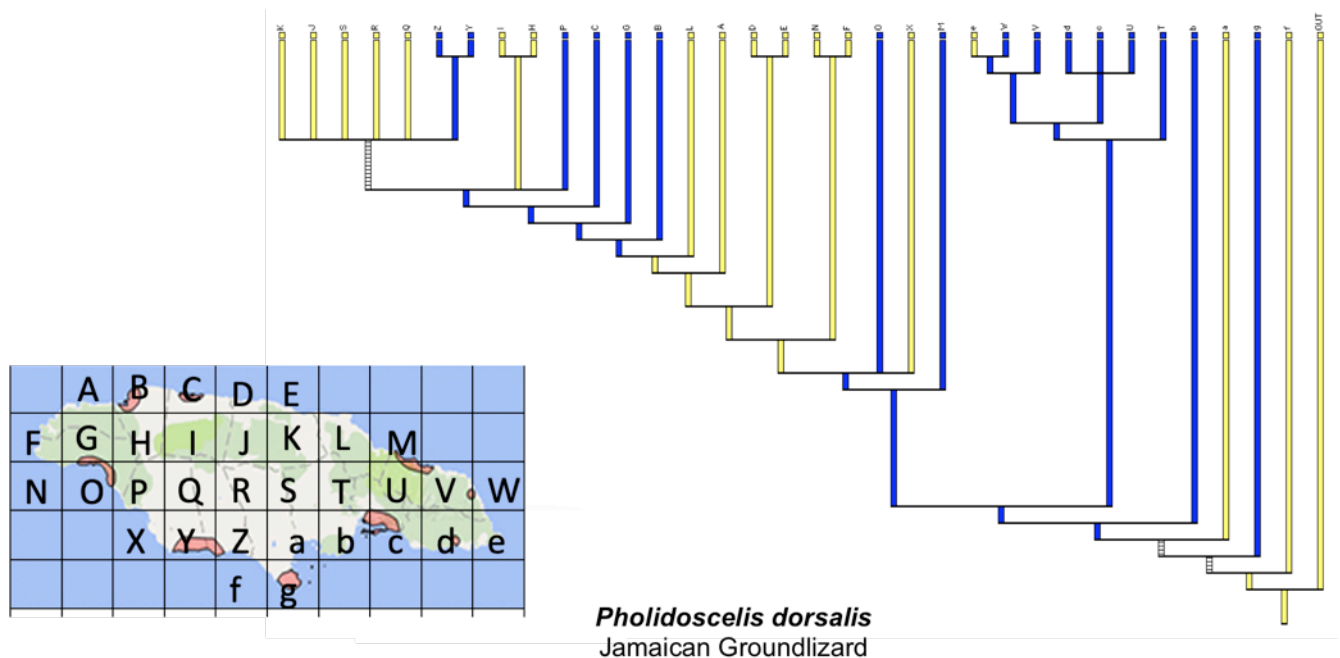

Figure 6. Distribution map and presence/absence states of *Pholidoscelis dorsalis* optimized on the PAE tree. This extreme example illustrates a taxon whose distributional patterns appear ecologically driven and do not contribute to the diagnosis of areas of endemism. See text for further discussion.

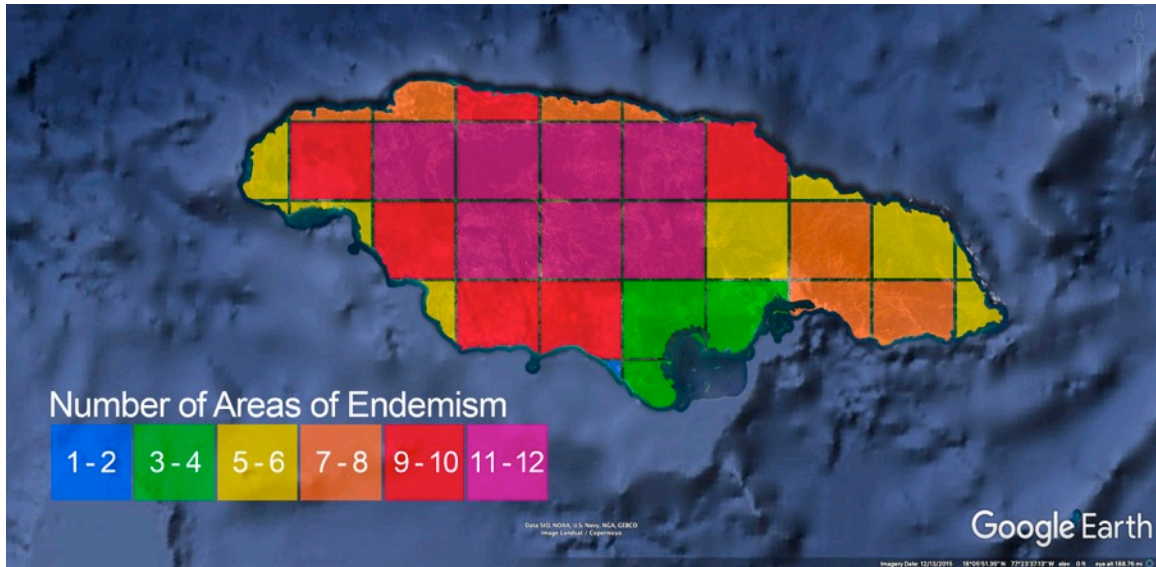

Figure 7. Number of hierarchically nested areas of endemism per grid.

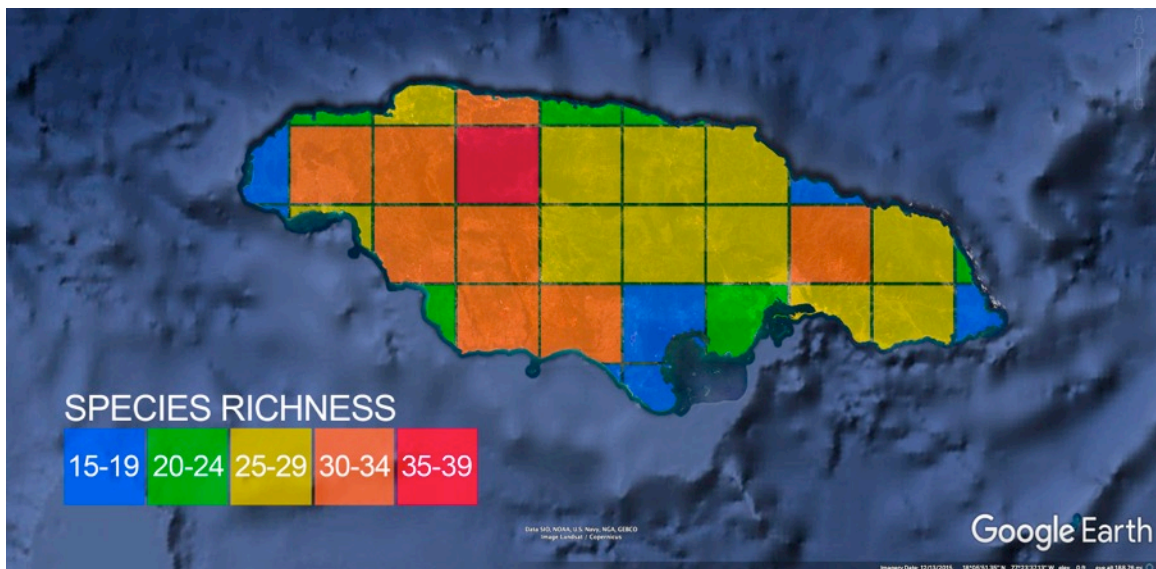

Figure 8. Total species richness per grid.

Inferences as to which is more likely often requires knowledge and insight into the environment of the region/area in question. The Blue Mountain Inlier, formed from Cretaceous sediments and volcanic/metamorphic rock, occupies the majority of the land area within the quadrat. The mountains are largely covered with thick primary and secondary tropical forests, which house a large number of the island's endemic species, but this knowledge

does not help in choosing which ad hoc claim, dispersal or extinction, is a better explanation. At minimum, however, recognizing such distributions as diagnostic reveals novel hypotheses available for testing.

Another common distributional pattern, that is less common in Cuba (Murray and Crother 2018), is highly peripheral around Jamaica, with taxa inhabiting coastal habitats, like taxon 8, the Jamaican Croaking Gecko

(*Aristelliger praesignis* (Hallowell, 1857)) (Fig. 4), and taxon 44, the Jamaican Groundlizard (*Pholidoscelis dorsalis* (Gray, 1838)) (Fig. 5). *Aristelliger praesignis* occupies five separate disjunct distributions around the coast of the island, with one inland locality. *Pholidoscelis dorsalis* occupies nine disjunct coastal distributions. Five other taxa share similar patterns and do not contribute to the diagnosis of any areas of endemism. These distributions are clearly ecologically driven, as opposed to historical, and may reflect an interesting biogeographic snapshot in time. This ecologically driven pattern may reflect the geologic history of the island, sourced in fauna by recent dispersal from neighboring islands, in that these distributions may reflect current progress in historical integration between lithosphere and biosphere. Therefore, at smaller spatial scales, such a distribution pattern may dissolve over time. Those ecologically distributed taxa are diagnostic, of course, at larger spatial scales, like Jamaica itself.

Patterns of species distributions across Jamaica can be viewed through areas of endemism or through more traditional species richness graphics. We find the comparison of the two approaches revealing because it presents the difference in patterns based on contemporary ecological processes versus patterns developed over evolutionary time. Figure 6 shows the number of areas of endemism per grid. This analysis is based on the idea that areas of endemism are nested hierarchically (Crother and Murray 2011). Essentially, the west-central two-thirds of the island have the most areas of endemism, thus the most species with unique distributions. In comparison, Figure 7, which shows species richness across the grids, reveals more isolated pockets of high species richness in the western and in the area of the Blue Mountains, with a drop of numbers in the central region. This disparity suggests both analyses are required for conservation oriented decisions and/or the disparity is simply a matter of scale and would

disappear at the correct scale (e.g. Daru et al. 2020).

Much like the purpose the photos and thermal imaging scans of a crime scene serve for forensics teams, the diagrams provided by the static method of PAE are meant to provide biogeographers with a reliable outline of a sequence of diverging events that convergently tie the defining significant characteristics of an area together - as single snapshots in time. In this way, they can serve as a platform for follow-up investigations such as CADE (Cladistic analysis of distributions and endemism; Porzecanski et al. 2005, Fattorini 2007b) or Brooks Parsimony Analysis (e.g. Brooks 1981, Brooks et al. 2001) which include phylogenetic history and can infer species area relationships in sectors or regions where differences in ranges, dispersal capability, and widespread to endemic species ratios are less pronounced than in other areas, or in larger scope analyses that relate multiple islands in the Caribbean or multi-regional landscapes to one another.

## ACKNOWLEDGEMENTS

Susan Koenig and Catherine Levy kindly shared their knowledge of Jamaica. Junior Darsan is thanked for his knowledge of Jamaican geography. The research was partially funded by the Edward G. Schlieder Foundation.

## AUTHOR CONTRIBUTIONS

LS, CM, and BC contributed equally to the conception, development, analysis, and writing of the manuscript. DM provided expert technical assistance with the development and production of figures.

## REFERENCES

- Brooks, D.R. (1981) Hennig's parasitological method: a proposed solution. *Systematic Zoology*, 30, 299–307. DOI: 10.2307/2413247.

- Brooks, D.R., Van Veller, M.G.P., & McLennan, D.A. (2001). How to do BPA, really. *Journal of Biogeography*, 28, 345–358. DOI: 10.1046/j.1365-2699.2001.00545.x
- Burke, K., Grippi, J., & Sengor, A.M.C. (1980) Neogene structures in Jamaica and the tectonic style of the northern Caribbean plate boundary zone. *Journal of Geology*, 88, 375–386. DOI: 10.1086/628522.
- Buskirk, R.E. (1985) Zoogeographic patterns and tectonic history of Jamaica and the northern Caribbean. *Journal of Biogeography*, 12, 445–461. DOI: 10.2307/2844953.
- Buskirk, R.E. (1992) Zoological and plate tectonic relationships of Jamaica to Central America. In: *Biogeography of Mesoamerica* (ed. by S.P. Darwin and A.L. Welden), pp. 9–16. Tulane University, New Orleans, LA.
- Carlquist S. (1974) *Island biology*. Columbia University Press, New York.
- Crisci, J.V., Katinas, L. & Posadas, P. (2003) *Historical Biogeography*. Harvard University Press, Cambridge.
- Crombie, R.I. (1999) Jamaica. In: *Caribbean amphibians and reptiles* (ed. by B.I. Crother), pp. 63–2. Academic Press, San Diego, CA. DOI: 10.1016/b978-012197955-3/50015-x.
- Crother, B.I. & Guyer, C. (1996) Caribbean historical biogeography: was the dispersal-vicariance debate eliminated by an extraterrestrial bolide? *Herpetologica*, 52(3), 440–465.
- Crother, B.I. & Murray, C.M. (2011) Ontology of areas of endemism. *Journal of Biogeography*, 38(6), 1009–1015. DOI: 10.1111/j.1365-2699.2011.02483.x.
- Crother, B.I. & Murray, C.M. (2013) Parsimony analysis of endemism under the “areas of endemism as individuals” thesis. *Cladistics*, 29(6), 571–573. DOI: 10.1111/cla.12023.
- Daru, B.H., Farooq, H., Antonelli, A. & Faurby, S. (2020) Endemism patterns are scale dependent. *Nature Communications*, 11, 2115. DOI: 10.1038/s41467-020-15921-6.
- Domning, Daryl P., Emry, R.J., Portell, R.W., Donovan, S.K. & Schindler, K.S. (1997) Oldest West Indian land mammal: rhinocerotoid ungulate from the Eocene of Jamaica. *Journal of Vertebrate Paleontology*, 17, 638–641. DOI: 10.1080/02724634.1997.10011013.
- Farr, T.A. (1984) Origins and endemism. *Jamaica Journal*, 17, 38–48.
- Fattorini, S. (2007a) Levels of endemism are not necessarily biased by the co-presence of species with different size ranges: A case study of Vilenkin and Chikatunov’s models. *Journal of Biogeography*, 34, 994–1007. DOI: 10.1111/j.1365-2699.2006.01678.x.
- Fattorini, S. (2007b) Historical relationships of African mountains based on cladistic analysis of distributions and endemism of flightless insects. *African Entomology*, 15, 340–355. DOI: 10.4001/1021-3589-15.2.340.
- Fattorini, S. (2017) Endemism in historical biogeography and conservation biology: concepts and implications. *Biogeographia – The Journal of Integrative Biogeography*, 32(1), 47–75. DOI: 10.21426/b632136433.
- Fattorini, S. & Fowles, A.P. (2005) A biogeographical analysis of the tenebrionid beetles (Coleoptera, Tenebrionidae) of the island of Thasos in the context of the Aegean islands (Greece). *Journal of Natural History*, 39, 3919–3949. DOI: 10.1080/00222930500533443.
- Geraads, D. (1998) Biogeography of circum-Mediterranean Miocene/Pliocene rodents; a revision using factor analysis and parsimony analysis of endemism. *Palaeogeography, Palaeoclimatology, Palaeoecology*, 137, 273–288. DOI: 10.1016/s0031-0182(97)00111-9.
- Graham, A. (2003) Historical phylogeography of the Greater Antilles. *Brittonia*, 55, 357–383. DOI: 10.1663/0007-196x(2003)055[0357:hpotga]2.0.co;2.
- Hedges, S.B. (1996) Vicariance and Dispersal in Caribbean Biogeography. *Herpetologica*, 52, 466–473.
- Hedges, S.B., Hass, C.A. & Maxson, L.R. (1992) Caribbean biogeography: molecular evidence for dispersal in West Indian terrestrial vertebrates. *Proceedings of the National Academy of Science USA*, 89, 1909–1913. DOI: 10.1073/pnas.89.5.1909.

- Hedges, S.B. (2018) Caribherp: amphibians and reptiles of Caribbean Islands. <http://www.caribherp.org/>. Philadelphia, Pennsylvania.
- Henderson, R.W. & Powell, R. (2009) Natural History of West Indian reptiles and Amphibians. University Press of Florida, Gainesville.
- Kueffer C, Drake D.R., Fernández-Palacios & J.M. (2014) Island biology: looking towards the future. *Biology Letters*, 10, 20140719. DOI: 10.1098/rsbl.2014.0719.
- Lavin, M. & Matos, A.B. (2008) The Impact of Ecology and Biogeography on Legume Diversity, Endemism, and Phylogeny in the Caribbean Region: A New Direction in Historical Biogeography. *Botanical Review*, 74, 178–196. DOI: 10.1007/s12229-008-9006-8.
- Levy, S. & Koenig, S. (2009) Jamaica. In: Important Bird Areas Americas - Priority sites for biodiversity conservation (ed. by C. Devenish, D.F. Díaz Fernández, R.P. Clay, I. Davidson & I. Yépez Zabala), Pp 261–268. BirdLife International (BirdLife Conservation Series No. 16), Quito, Ecuador.
- Lewis, J.F. & Draper, G. (1990) Geology and tectonic evolution of the northern Caribbean margin. In: The Caribbean Region (ed. by G. Dengo & J.E. Case), pp. 77–140. Geological Society of America, Boulder, Colorado. <https://doi.org/10.1130/dnag-gna-h.77>.
- Lynn, W.G. (1940) Amphibians. In: The Herpetology of Jamaica (ed. by W.G. Lynn & C. Grant), pp. 3–60. The Institute of Jamaica, Kingston.
- Lynn, W.G. & Grant, C. (1940) The Herpetology of Jamaica. The Institute of Jamaica, Kingston.
- MacPhee, R.D.E. (2005) 'First' Appearances in the Cenozoic Land-Mammal Record of the Greater Antilles: Significance and Comparison with South American and Antarctic Records. *Journal of Biogeography*, 32, 551–564. DOI: 10.1111/j.1365-2699.2005.01231.x.
- Matos-Maraví, P., Águila, R.N., Peña, C., Miller, J., Sourakov, A. & Wahlberg, N. (2014) Causes of endemic radiation in the Caribbean: evidence from the historical biogeography and diversification of the butterfly genus *Calisto* (Nymphalidae: Satyrinae: Satyrini). *BMC Evolutionary Biology*, 14, 199. DOI: 10.1186/s12862-014-0199-7.
- Meyerhoff, A.A. & Kreig, E.A. (1977) Jamaican petroleum potential; 2, five major cycles make up Jamaican tectonic and structural history, Part 2. *Oil Gas Journal*, 75, 141–146.
- Morrone, J.J. (2001) Toward a cladistic model for the Caribbean subregion: delimitation of areas of endemism. *Caldasia*, 23(1), 43–76.
- Morrone, J.J. (2014) Parsimony analysis of endemism (PAE) revisited. *Journal of Biogeography*, 41(5), 842–854. DOI: 10.1111/jbi.12251.
- Murray, C.M. & Crother, B.I. (2018) Squamate areas of endemism in Cuba as determined by parsimony analysis of endemism. *Cladistics*, 35(4), 426–434. DOI: 10.1111/cla.12358.
- Parenti, L.R. & Ebach, M.C. (2009) Comparative biogeography: discovering and classifying biogeographical patterns of a dynamic Earth. University of California Press, Berkeley and Los Angeles. DOI: 10.1643/ot-10-026
- Peck, S.B. (1999) Historical biogeography of Jamaica: evidence from cave invertebrates. *Canadian Journal of Zoology*, 77, 368–380. DOI: 10.1139/z98-220.
- Porzecanski, A.L., & Cracraft, J. (2005) Cladistic analysis of distributions and endemism (CADE): using raw distributions of birds to unravel the biogeography of the South American aridlands. *Journal of Biogeography*, 32, 261–275. DOI: 10.1111/j.1365-2699.2004.01138.x
- Pregill, G.K. (1999) Eocene Lizard from Jamaica. *Herpetologica*, 55, 157–161.
- Rosen, B.R. (1988). From fossils to earth history: applied historical biogeography. In: Analytical Biogeography (ed. by A.A. Myers & P.S. Giller), pp. 437–481. Springer, Dordrecht. DOI: 10.1007/978-94-009-1199-4\_17.
- Santiago-Valentin, E. & Olmstead, R.G. (2004) Historical biogeography of Caribbean plants: introduction to current knowledge and possibilities from a phylogenetic perspective. *Taxon*, 53, 299–319. DOI: 10.2307/4135610.
- Schwartz, A. & Henderson, R.W. (1991) Amphibians and reptiles of the West Indies:

- descriptions, distributions, and natural history. University of Florida Press, Gainesville.
- Schwartz, A. & Fowler, D.C. (1973). The Anura of Jamaica: a progress report. *Studies on the Fauna of Curacao and other Caribbean Islands*, 142, 51–142.
- Swofford, D.L. (2002) PAUP\*. Phylogenetic Analysis Using Parsimony (\*and Other Methods). Version 4.159. Sinauer Associates, Sunderland, MA.
- Uit de Weerd DR, Robinson DG, Rosenberg G. (2016) Evolutionary and biogeographical history of the land snail family Urocoptidae (Gastropoda: Pulmonata) across the Caribbean region. *Journal of Biogeography*, 43, 763–777. DOI: 10.1111/jbi.12692.
- Valls Alvarez, R.A. (2009) Geological evolution of the NW corner of the Caribbean Plate. In: *The Origin and Evolution of the Caribbean Plate* (ed. by K.H. James, M.A. Lorente & J.L. Pindell), pp. 205–218. The Geological Society of London, Special Publication 328. London, UK. DOI: 10.1144/sp328.10.
- Walter, H.S. (2004) The mismeasure of islands: implications for biogeographical theory and the conservation of nature. *Journal of Biogeography*, 31, 177–197. DOI: 10.1046/j.0305-0270.2003.00989.x.
- Weaver, P.F., Cruz, A., Johnson, S., Dupin, J. & Weaver, K.F. (2016) Colonizing the Caribbean: biogeography and evolution of livebearing fishes of the genus *Limia* (Poeciliidae). *Journal of Biogeography*, 43(9), 1808–1819. DOI: 10.1111/jbi.12798.
- Whittaker, R.J., Fernández-Palacios, J.M., Matthews, T.J., Borregaard, M.K., Triantis, K.A. (2017) Island biogeography: Taking the long view of nature's laboratories. *Science*, 357(6354), eaam8326. DOI: 10.1126/science.aam8326.
- Whittaker, R.J., Fernández-Palacios, J.M. (2007) *Island Biogeography: Ecology, Evolution, and Conservation*. Oxford University Press, Oxford.

*Submitted: 14 April 2021*

*First decision: 2 May 2021*

*Accepted: 11 May 2021*

*Edited by Simone Fattorini*