

Lawrence Berkeley National Laboratory

Recent Work

Title

THE ACTIVATION AND COVALENT BINDING OF A CHEMICAL CARCINOGEN TO DNA

Permalink

<https://escholarship.org/uc/item/19z0h81g>

Author

Straub, K.M.

Publication Date

1979-04-01

THE ACTIVATION AND COVALENT BINDING
OF A CHEMICAL CARCINOGEN TO DNA

Kenneth Marshall Straub
(Ph. D. thesis) ✓

April 1979

RECEIVED
LAWRENCE
BERKELEY LABORATORY

MAY 30 1979

LIBRARY AND
DOCUMENTS SECTION

Prepared for the U. S. Department of Energy
under Contract W-7405-ENG-48

TWO-WEEK LOAN COPY

This is a Library Circulating Copy
which may be borrowed for two weeks.
For a personal retention copy, call
Tech. Info. Division, Ext. 6782

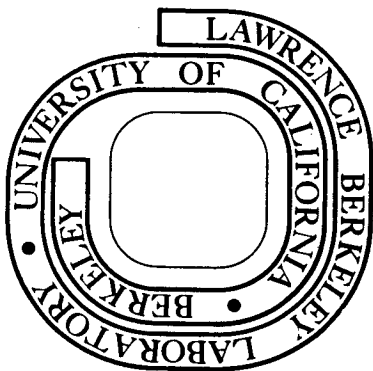

DISCLAIMER

This document was prepared as an account of work sponsored by the United States Government. While this document is believed to contain correct information, neither the United States Government nor any agency thereof, nor the Regents of the University of California, nor any of their employees, makes any warranty, express or implied, or assumes any legal responsibility for the accuracy, completeness, or usefulness of any information, apparatus, product, or process disclosed, or represents that its use would not infringe privately owned rights. Reference herein to any specific commercial product, process, or service by its trade name, trademark, manufacturer, or otherwise, does not necessarily constitute or imply its endorsement, recommendation, or favoring by the United States Government or any agency thereof, or the Regents of the University of California. The views and opinions of authors expressed herein do not necessarily state or reflect those of the United States Government or any agency thereof or the Regents of the University of California.

The Activation and Covalent Binding
of a Chemical Carcinogen to DNA

By

Kenneth Marshall Straub

ABSTRACT

Trace environmental chemical contaminants are now known to be significant factors in the induction of neoplasia in humans. Most chemical carcinogens are not active as the parent compound, but require conversion in vivo to proximate or ultimate carcinogenic forms by metabolism. The activated carcinogen can then undergo reactions in the cell, including covalent binding to informational macromolecules such as DNA, RNA, and protein. Based largely on correlative evidence, it has become axiomatic that this covalent binding to cellular macromolecules is a necessary, initial step in the process of carcinogenesis. Experimentally, it is observed that carcinogens become covalently bound to a greater extent than do non-carcinogens.

The work described in this dissertation involved a study of the activation and covalent binding to DNA of a widespread environmental carcinogen, benzo(a)pyrene (BaP, structure I). An in vitro DNA-binding assay based on purified rat liver microsomes was used to isolate picomole quantities of the bound carcinogen-nucleic acid complex. The products of this reaction were studied by fluorescence spectroscopy and allowed identification of the activated hydrocarbon as a 7,8-dihydroxy-7,8,9,10-tetrahydrobenzo(a)pyrene. These results, along with current literature studies on the metabolism of benzo(a)pyrene and on

the mutagenic activity of its metabolites suggested the identity of the active form as a 7,8-dihydroxy-9,10-epoxy-7,8,9,10-tetrahydrobenzo(a)pyrene (BaP-diol epoxide, structure II). This material was synthesized and reacted with a variety of DNA's (calf thymus, SV40, ØX174) in vitro; the products were observed to be chromatographically identical to the hydrocarbon-nucleoside adducts obtained from microsomal enzyme-mediated binding of benzo(a)pyrene to DNA.

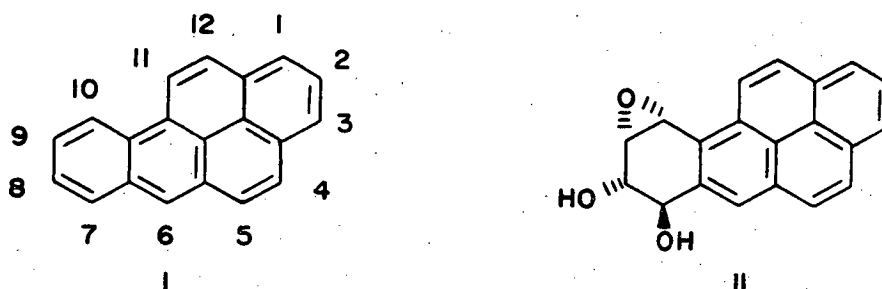

The structures of the DNA-diol epoxide adducts (available in microgram quantities) were investigated by high resolution electron-impact mass spectrometry, field desorption mass spectrometry, and double labelling ($^3\text{H}/^{14}\text{C}$) studies. This allowed identification of the nucleoside moieties of the adducts as deoxyguanosine (92%), deoxyadenosine (5%), and deoxycytidine ($\leq 3\%$). Binding to deoxyguanosine and deoxyadenosine residues involves the N^2 or N^6 exocyclic amino groups with linkage to the hydrocarbon at C-10.

Resolution of the (+) *r*-7, *t*-8-dihydroxy-*t*-9,10-epoxy-7,8,9,10-tetrahydrobenzo(a)pyrene into its optical antipodes and subsequent reaction of each enantiomer with DNA allowed the observation of stereoselective binding of a chemical carcinogen to native duplex DNA. That is, the (+) enantiomer (7R,8S,9R,10R) binds much more efficiently (20:1 ratio) to native, double-stranded DNA than does the (-) enantiomer (7S,8R,9S,10S).

This difference in binding between enantiomers is dependent upon the secondary structure of the nucleic acid; with single-stranded or denatured DNA, stereoselective binding of enantiomers is abolished. A model to account for these observations is proposed, involving stereoselective physical interactions (intercalation) prior to covalent binding. An analysis of literature data on the mutagenic and tumorigenic activities of optically active benzo(a)pyrene metabolites indicates that the biological activity of the enantiomeric diol epoxides parallels their DNA-binding activity.

The implications of these results are discussed, with reference to the effects of xenobiotic-modified residues on the structure and function of DNA. In addition, the analytical techniques developed as part of this research program should prove useful in the general areas of drug metabolism and the structural elucidation of chemically modified biopolymers.

Melvin Calvin
April 10, 1979

The Activation and Covalent Binding
of a Chemical Carcinogen to DNA

Copyright c 1979

by

Kenneth Marshall Straub

ACKNOWLEDGMENTS

When writing acknowledgments it is impossible to include everyone to whom one is indebted. However, the following individuals made substantial contributions which made the completion of this dissertation possible, and it is to these contributors that I express my deepest gratitude:

Dr. Melvin Calvin, whose continued enthusiasm, support, and advice made much of the work possible;

Dr. Thomas Meehan, with whom many of the ideas and experiments reported in this dissertation originated and were carried out;

Dr. A.L. Burlingame, whose enthusiastic support for mass spectrometry led to the use of this technique as a major structure-solving tool in the work reported in this dissertation;

Dr. Susan Hawkes, who attempted to balance out the chemical bias in this work by continual references to cell biology, and whose constant reminders led to the completion of this dissertation;

Drs. Howard Gamper, Gordon Parry, Joseph Landolph, Joseph Becker, and James Bartholomew for many useful and stimulating conversations;

Mrs. Marilyn Taylor, for providing invaluable personal advice and assistance;

Ms. Brenda Megerle, for typing this dissertation and for identifying potentially embarrassing errors in grammar and spelling.

The work reported in this dissertation was supported in part by the Department of Chemistry, University of California at Berkeley; by the Department of Energy, Office of Health and Environmental Research, under contract # W-7405-ENG-48; and by the National Cancer Institute, under contract # Y01-CP 50203.

TABLE OF CONTENTS

	<u>Page Number</u>
Chapter 1: Introduction	1
Chapter 2: Preliminary Structural Studies	15
Chapter 3: Synthesis of Benzo(a)pyrene Derivatives	42
Chapter 4: DNA Binding Studies	103
Chapter 5: Stereoselective Binding of Proximate Carcinogens to DNA	149
Chapter 6: Conclusions	173
References	181
Appendix: Analysis of (+)anti-Diol Epoxide-DNA Adducts by Field Desorption Mass Spectrometry	195

Chapter I: Introduction

The recognition that trace environmental contaminants can have a significant effect on human health is one of the profound changes that has occurred in biomedical science over the past twenty-five years. One example of this is the induction of cancer by exposure to chemicals. Both synthetic and naturally occurring chemicals have been implicated in the etiology of a wide variety of cancers: for example, benzidine (I), a synthetic dye intermediate, has been shown to be a major causative factor in the induction of carcinomas involving the urinary bladder.¹ Aflatoxin B₁ (II), in contrast, is a naturally occurring fungal metabolite that is known to be a potent hepatocarcinogen.² The list of known or suspected carcinogens

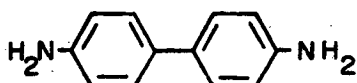

I

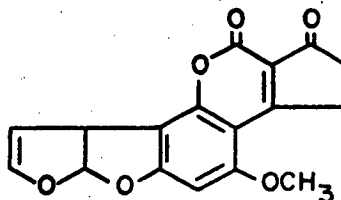

II

continues to grow, as evidenced by such recent additions as vinyl chloride,³ methyl chloromethyl ether,⁴ and hexamethyl phosphoramide.⁵ A further incrimination of chemicals as primary causative agents in cancer has been demonstrated by epidemiological studies involving migrant populations, where the incidence of cancer changes to that of the adopted country in the course of one or two generations.^{6,7} Thus

Japan has a high incidence of stomach cancer and a low incidence of colon cancer, with the reverse situation being true for the United States. First generation offspring of Japanese immigrants to the United States show an increased incidence of colon cancer and a decreased incidence of stomach cancer, while second generation offspring show incidences of colon and stomach cancer essentially identical to that of the United States population as a whole. Clearly the environment (presumably diet) is playing a major role with respect to cancer type and incidence. Some epidemiological studies have suggested that as much as 80% of all human cancers have environmentally determined causes or contributing factors.⁸ Of course, it must be realized that "cancer" describes a great many disease states, and that genetic, viral, and metabolic effects can all be involved through complex interactions in mediating the response of an organism to the environment.

A vast number of different chemical structures have been shown to be capable of causing cancer in test animals or in humans (Table I).⁹ It is apparent that no single molecular feature is common to all of these chemicals. One of the more intriguing chemical types is the class of compounds known as polycyclic aromatic hydrocarbons (PAH's). Probably the first report attributing the induction of neoplasia to an environmental agent concerned PAH's: in 1775, Percival Pott, a London surgeon, attributed the occurrence of scrotal cancer in chimney sweeps to their occupational exposure to soot, a material now known to contain PAH's.¹⁰ The first defined chemical structure to be identified as a chemical carcinogen was also a PAH: in 1933 Cook, Hewett, and Hieger were able to fractionate coal tar and isolate a pure chemical compound

(benzo(a)pyrene, BaP, structure III) that exhibited carcinogenic activity in test animals.¹¹

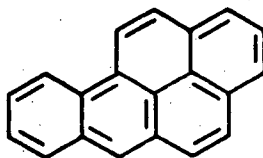

III

It was only after this work proved that a single pure chemical compound was capable of inducing cancer that detailed work on the biochemistry of tumor induction could begin.

Table I
Known Chemical Carcinogens⁹

Chemical	Target Tissue
2-Naphthylamine	Urinary bladder
Benzidine	Urinary bladder
4-Aminobiphenyl	Urinary bladder
Chloromethyl methyl ether	Lungs
Aflatoxins	Liver
Diethyl Stilbestrol	Vagina
Vinyl chloride	Liver
Nitrosamines	Liver, kidney, stomach, esophagus
Hexamethyl phosphoramide	Mucosa
Bis(2-chloroethyl)sulfide	Lungs
Soot, tar, oil	Skin, lungs

Research on chemical carcinogenesis over the next twenty years was largely concerned with determining what interactions these compounds could participate in with the test organism. Preliminary

investigations were able to determine that injected PAH's rapidly disappeared from the site of injection and underwent changes in their fluorescent properties.¹² Whole animal studies using rats showed that a variety of different fluorescent products appeared in the urine and bile after administration of the carcinogen.¹³ The availability of ³H and ¹⁴C-labelled carcinogens in the 1940's and 1950's made possible studies on the metabolism of a number of chemical carcinogens. PAH's such as benzo(a)pyrene were shown to undergo transformation to more polar species such as phenols, dihydrodiols, and water-soluble conjugates with sugars and amino acids.¹⁴ It was also observed that carcinogenic PAH's became covalently bound to mouse skin proteins, DNA, and RNA after repeated topical application of the compound to a shaved area of the mouse.¹⁵⁻²¹ Parallel work by the Millers at the University of Wisconsin demonstrated that another class of chemical carcinogens, aromatic amines, could also undergo biotransformation and covalent binding to cellular macromolecules.²²⁻²³ In most instances (the exception being highly reactive alkylating agents such as ethyl methane sulfonate or nitrosamines) chemical carcinogens do not undergo covalent binding to cellular constituents when incubated with purified DNA, RNA, or protein, so that metabolism of the compound appears to be required to effect such binding.²⁴ These two conclusions, the need for metabolic activation of most carcinogens, and the correlation between macromolecule binding and biological activity provided a framework within which further investigations could be carried out.

Once the importance of metabolic activation had been established,

researchers began to emphasize work that would lead to a detailed understanding of the metabolism of different classes of carcinogens. Studies on PAH metabolism up to 1965 had mostly served to establish the overall pattern of biotransformation--- i.e., parent compounds underwent conversion to more polar materials, including phenols, diols, and conjugates with sugars, amino acids, and other small molecules. With few exceptions, the detailed chemical structures proved to be based on marginal evidence, such as absorption spectra or chromatographic behavior. The main reason for this state of affairs was a lack of pure reference compounds. Nevertheless, the overall pattern of metabolism as illustrated in Figure 1 has proven to be quite general.²⁵

PAH Metabolism

The nature of the metabolites observed with a number of PAH's led Boyland in 1950 to postulate that epoxides were the initially formed intermediates which could then undergo rearrangement to phenols or reaction with nucleophiles (H_2O , glutathione, etc.) to other products.²⁶ The arene oxides thus formed were an unknown class of compounds at the time of this proposal; the challenge to synthetic chemistry thus posed and a discussion of arene oxide chemistry is presented in chapter 3. A further impetus to research on arene oxides was the discovery of the "NIH shift" in 1966; this rearrangement concerns the migration and retention of a substituent "X" that occurs during the monooxygenase-catalyzed formation of phenols from aromatic substrates:²⁷

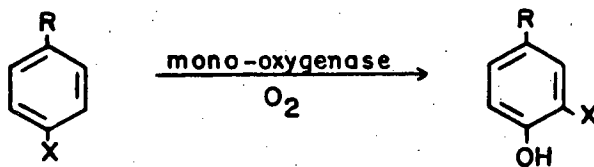

The occurrence of this shift suggested that such aromatic hydroxylations are actually epoxidations, and that the intermediate arene oxides undergo isomerization to phenols with concomitant migration and retention of the substituent "X":²⁸

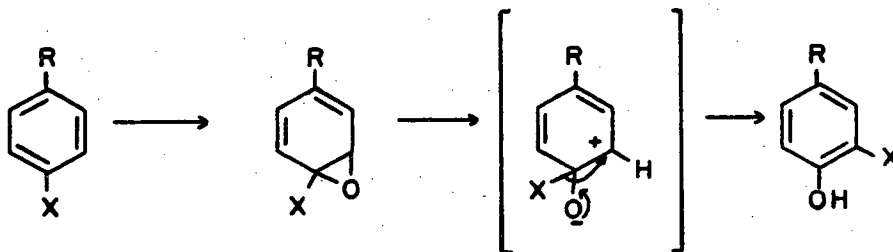

In 1970 Jerina and coworkers were able to demonstrate conclusively that an arene oxide was an obligatory intermediate in the microsomal hydroxylation of naphthalene.²⁹ This work involved isolation of the intermediate formed by incubating naphthalene with a cell-free microsomal enzyme preparation and comparison of its properties with synthetic naphthalene-1,2-epoxide. Figure 2 outlines the results obtained for the metabolism of naphthalene by a crude liver homogenate. The generality of this oxidative pathway in aromatic substrate metabolism has been established for a variety of cases, and several indirect criteria are now accepted as evidence that arene oxides are involved: i) the occurrence of the NIH shift during the formation of a phenol; ii) the formation of glutathione conjugates

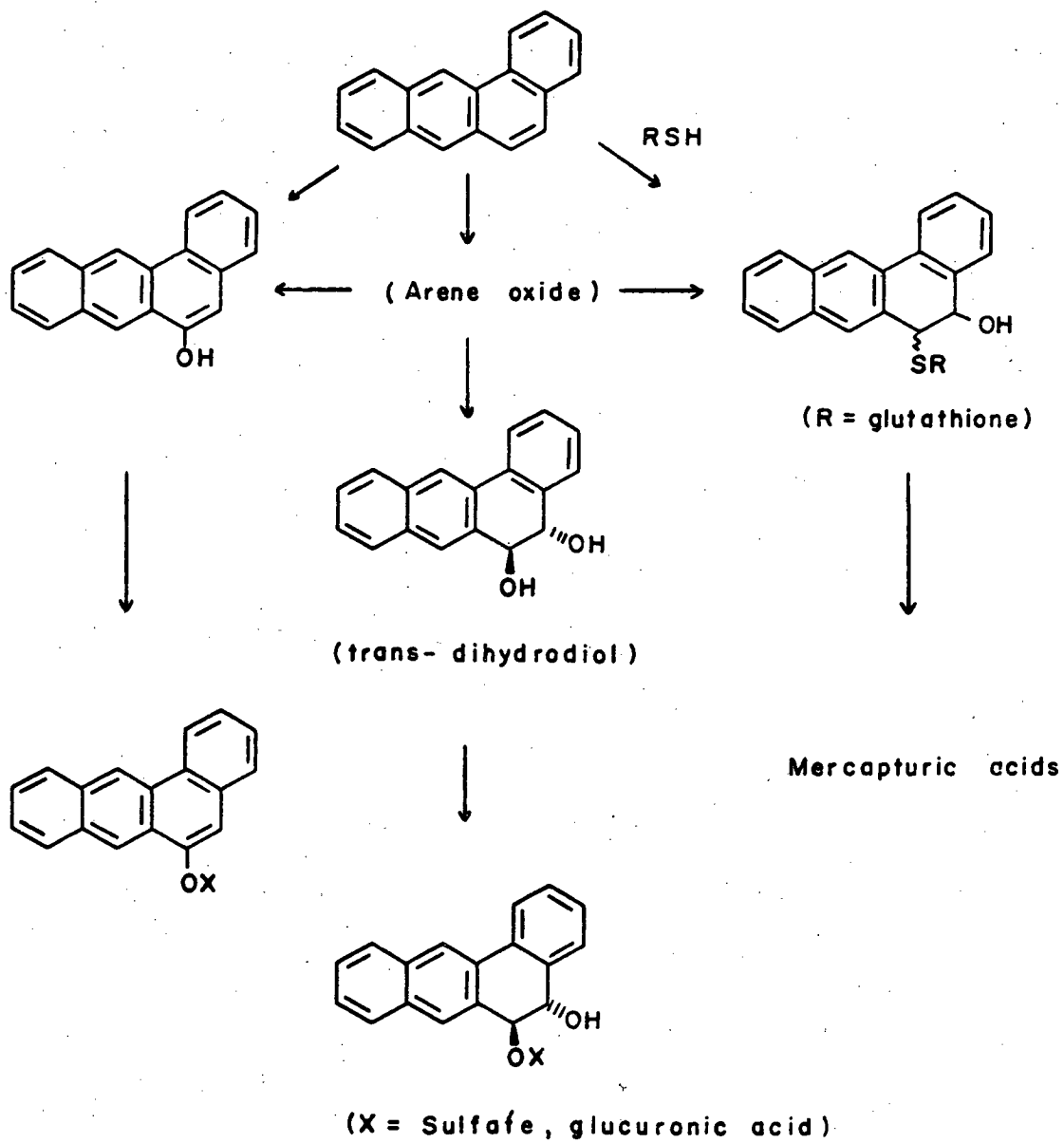

Figure 1: PAH Metabolism in the rat ²⁵

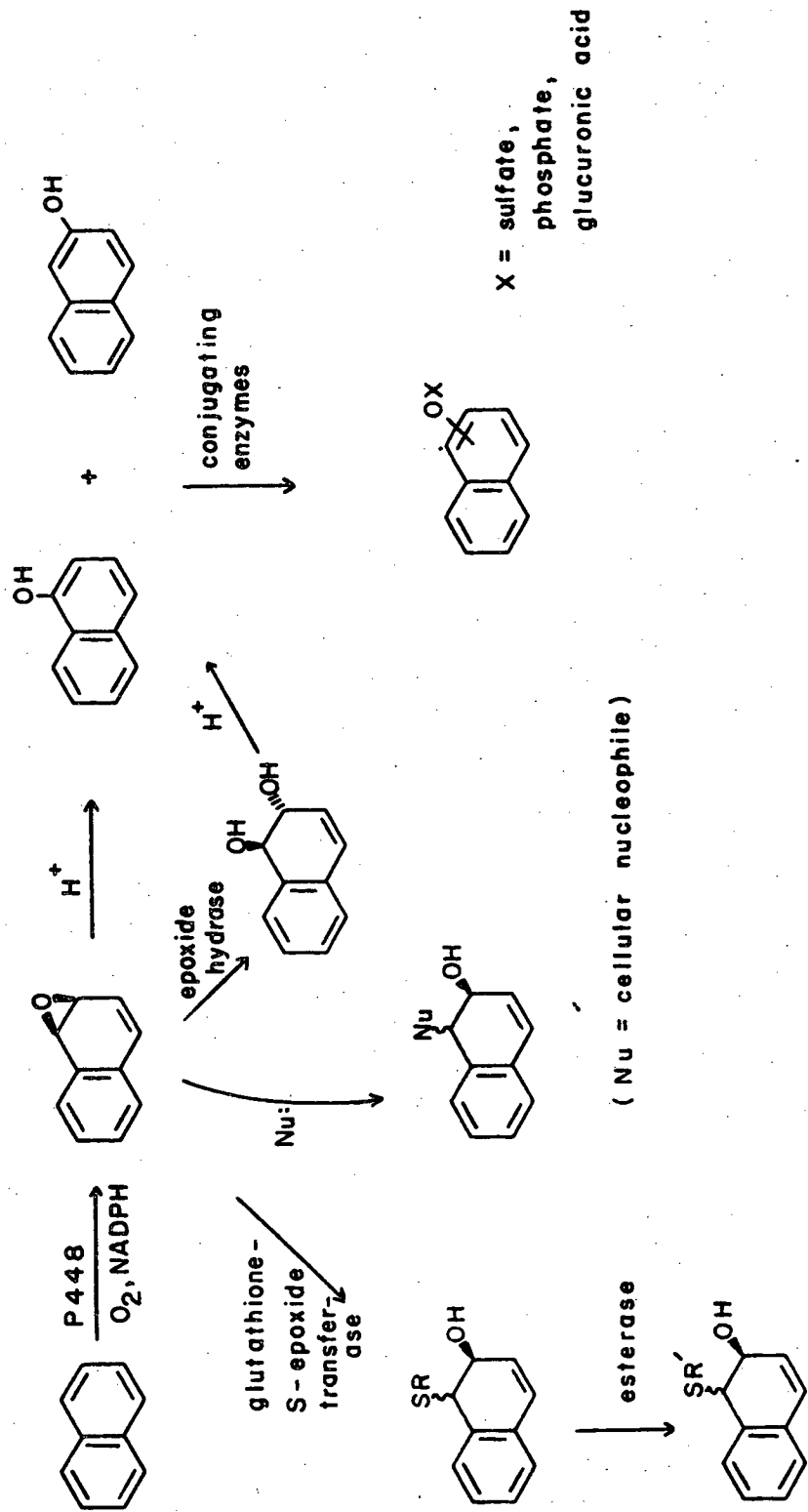
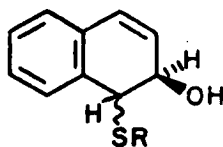

Figure 2: Microsomal enzyme-mediated metabolism of naphthalene 29

or mercapturic acids of general structure IV, and iii) the formation of trans-dihydrodiols and their conjugates.³⁰



IV

The recognition of the general importance of arene oxides in the metabolism of aromatic substrates led to an intensive investigation of the enzymes involved in microsomal hydroxylations. These reactions are catalyzed by a class of non-specific mono-oxygenases localized in the endoplasmic reticulum of the cell, referred to as cytochrome P-450 type oxidases.³¹ Activity is found in a wide variety of tissue types, but is highest in the liver. The enzyme is highly inducible; in rat liver the induced level can account for as much as 6% by weight of the total cellular protein. Prior to 1975, two distinct enzymes were recognized: P-450 (so-called because its absorption spectrum in the presence of CO has a maxima at 450 nm), induced by exposure to phenobarbital; and P-448 (absorption maxima at 448 nm in the presence of CO), inducible by exposure to 3-methylcholanthrene, benzo(a)pyrene, or 2,3,7,8-tetrachloro-p-dioxin (TCDD). The purified enzyme has a molecular weight of between 26,000 and 60,000 daltons and requires lipid for activity.³² Figure 3 shows a schematic representation of the oxidation mechanism.³³ Molecular oxygen and two electrons (provided by NADPH and its carrier protein, cytochrome P-450 reductase) are made to react with the aromatic substrate, resulting in oxidized substrate and water. The arene oxide thus formed is a

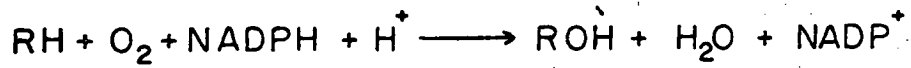
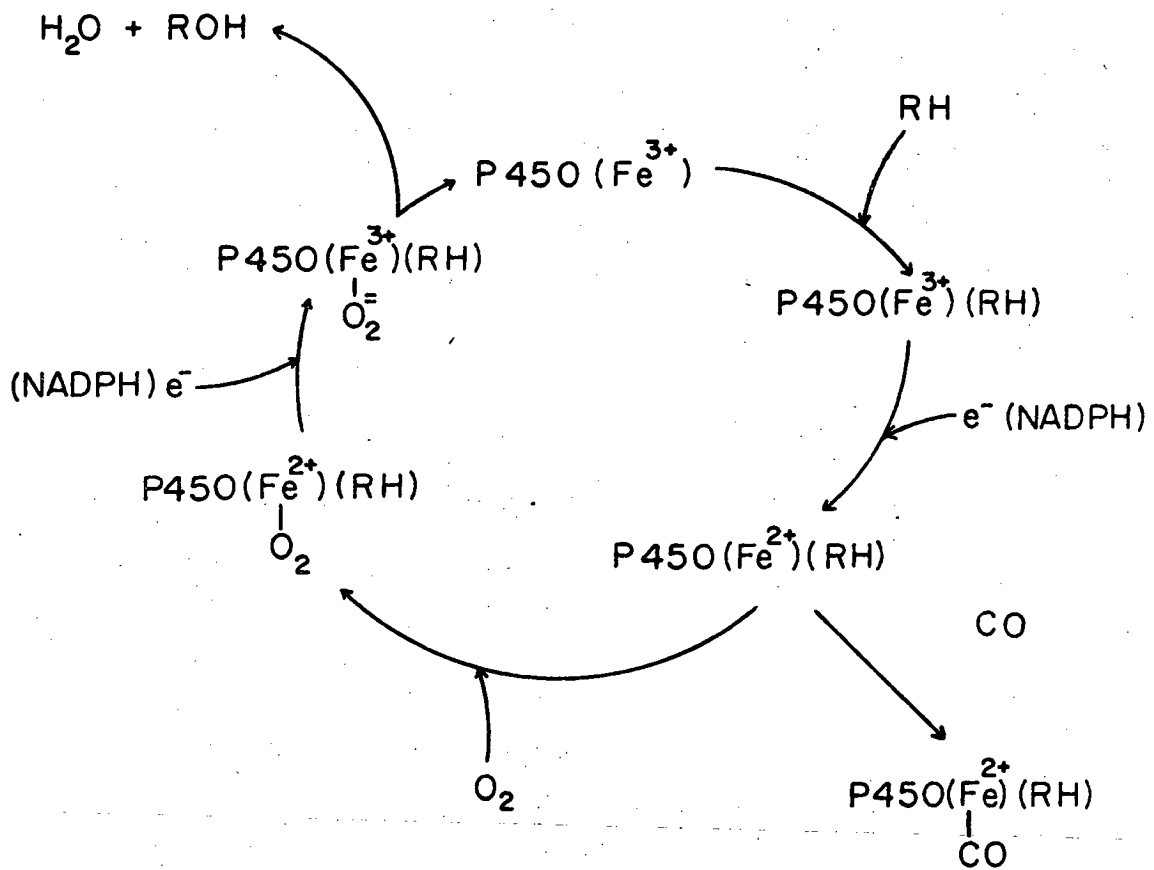
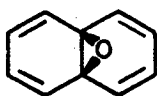
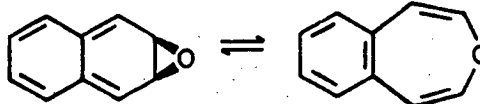

Figure 3: Cytochrome P450 - mediated oxidation ³³

highly labile species, and may undergo further enzymatic transformation or reaction with available nucleophiles. The reactivity of different substrates with the mono-oxygenase enzyme varies considerably, as does enzyme activity in different tissues or species. The explanation for this is the large number of different isoenzymes present in a given tissue; a discussion of this complicating feature is delayed until chapter 6. The reaction of the initially formed arene oxide with certain nucleophiles such as water or glutathione is also enzyme-mediated. Epoxide hydrase catalyzes the reaction with water to generate a trans-dihydrodiol, and glutathione-S-epoxide transferase catalyzes the addition of reduced glutathione to the epoxide.³⁴ A suite of energy-requiring conjugating enzymes regulates the formation of glucuronides and sulfates.^{35,36} These various enzymatic pathways are outlined in Figure 2, using naphthalene as an example. With naphthalene, only the 1,2-oxide is formed; oxepin tautomers which would be generated by epoxidation of the 3,4 or 8a, 4a bonds are not observed (structures V, VI).²⁹ In general, epoxidation of a large multi-ring PAH such as benzo(a)pyrene would be expected to yield a large number of products, since epoxidation can potentially occur at any site on the molecule.



V



VI

Covalent Binding to Macromolecules: A General Description of the Research Problem

The advent of radioactive isotopes in the late 1940's enabled researchers to begin mapping out the metabolic fate of carcinogens in the test organism.⁹ Almost immediately, it was observed that a small but detectable level of radioactivity became permanently bound to various cellular components. This observation has been verified for a wide variety of chemical carcinogens.³⁷ Based largely on correlative evidence, it has become axiomatic that this covalent binding to cellular macromolecules is a necessary, initial step in the process of carcinogenesis. The experimental observation is that biologically active (i.e., tumorigenic, either by topical application, injection, or oral feeding) compounds become bound to a greater degree than do biologically inactive compounds.²⁴ These results apply to the three major classes of biomolecules involved in information storage, processing, and control--DNA, RNA, and protein. The binding to DNA is significant for a variety of reasons. DNA is, of course, the genetic material, and non-regulated reactions involving DNA would be expected to have an effect on growth properties and metabolic regulation within the cell. The importance of RNA and protein to the integrity of the cell is also paramount; nevertheless, the simplifying appeal of somatic mutational theories of tumorogenesis lend some support to DNA as a critical target molecule of chemical carcinogens. Investigations of the comparative binding efficiency of carcinogens with all three target molecules also tend to emphasize the significance of DNA binding: carcinogens bind to DNA to a greater extent than do non-carcinogens, and the amount of binding correlates in a linear fashion

with tumorigenicity (as defined by quantities such as the "Iball Index," equal to the number of animals with tumors divided by the latency period).^{9,19} The covalent binding that occurs to RNA and protein is also of potential significance, but correlations with tumorigenic activity are not as good as for DNA binding, and in some cases show no binding specificity or relation to tumorigenic activity.³⁸

A final supporting argument for the involvement of DNA binding with tumorigenic behavior is the close correlation between mutagenic activity and carcinogenic activity. DNA is known to be the target molecule in many mutagenesis test systems, such as the his ⁺S. typhimurium system of Ames,³⁹ or the systems based on resistance to the toxic effects of 8-azaguanine in certain eukaryotic cell lines.⁴⁰ Neoplasia is, of course, a complicated disease process, involving a constellation of diverse biological effects. There no doubt are instances where viral, epigenetic, or other causative factors are involved. Nevertheless, the phenomenon of covalent binding to DNA is an observation deserving of further investigation.

The research effort we undertook, then, had the following goals:

- 1) To define the nature of the active alkylating species formed by metabolic activation of a PAH-derived carcinogen.
- 2) To define the structure of the stable, covalent adducts formed between this activated carcinogen and DNA.
- 3) To define and investigate the effects of the covalently bound carcinogen on DNA structure and function.

The PAH we chose to study was benzo(a)pyrene (BaP, structure III), the first isolated PAH shown to possess carcinogenic activity. This compound is widely distributed in the environment, and undergoes complex

metabolic transformations in eukaryotic cells. Most importantly, it was known to undergo covalent binding to DNA in vivo (at the level of $1:10^5$ base pairs) and there existed an in vitro DNA-binding assay for the compound. In addition, a biologically inactive isomer (benzo(e)pyrene, structure IIIa) was available for comparison.

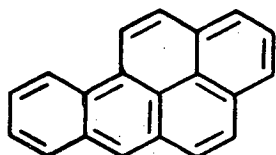

III

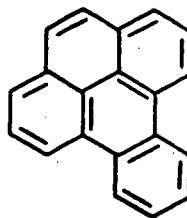

IIIa

As will be demonstrated, complete answers to 1) and 2) above have been obtained, and a partial answer to 3). The results obtained by ourselves and other research groups over the past five years (1973-1978) have led to a further set of questions, centering on the effects of xenobiotic-modified residues on the structure of DNA, the role of DNA repair in maintaining the biological integrity of the cell, and the effects of chemical carcinogens on cell cycle parameters and growth control. In addition, the analytical techniques developed as part of this research program should prove useful in the general areas of drug metabolism and structural elucidation of chemically modified biopolymers.

Chapter 2: Preliminary Structural Studies

In 1969 Gelboin⁴¹ and Grover and Sims⁴² independently showed that an in vitro system containing rat liver microsomes, NADPH, and oxygen was capable of catalyzing the covalent (i.e., non-extractable) binding of ³H-benzo(a)pyrene to calf thymus DNA. Binding levels were extremely low (similar to those observed in vivo), at between one hydrocarbon per 50,000 to 500,000 base pairs. The reaction was shown to require NADPH and oxygen. Total binding per mg of protein in the incubation mixture was increased when microsomes from rats pretreated with 3-methylcholanthrene (a potent inducer of P-448 type cytochromes) were used. Further studies with this system showed that binding of benzo(a)pyrene to RNA synthetic homopolymers could also occur, and that binding was most efficient with guanosine-containing polymers.⁴³ Using poly(G) as the nucleic acid substrate, Meehan and coworkers were able to increase the binding level to approximately 1:30,000 base pairs.⁴⁴ In addition to this, the use of double-labelled benzo(a)pyrene [7,10-¹⁴C; 1,3,6-³H] demonstrated that both labels were retained on binding. This result suggested that a radical cation mechanism for binding (involving formation of a 6-oxy radical) proposed by Nagata et al.⁴⁵ and Lesko et al.⁴⁶ was probably not a major contributing factor in enzyme-mediated binding. Inhibitors of P-450-type cytochromes, such as 7,8-benzoflavone, decreased the amount of binding. It was also shown that the modified poly(G) could be either

enzymatically or chemically (base hydrolysis) hydrolyzed to mononucleotides, and a $^{14}\text{C}/^3\text{H}$ -containing material with the chromatographic properties of a nucleotide was isolated.

It was decided that an attempt would be made to define the overall hydrocarbon structure of this isolated material. If the structure of the reactive hydrocarbon metabolite responsible for poly(G) binding could be determined, synthesis of larger quantities might become feasible. This would then allow a detailed investigation of the nucleic acid-hydrocarbon structures, as well as studies on the effects of such material on cellular functions. The extremely low level of binding meant that only picomolar quantities of material would be available for analysis. This necessitated the use of indirect methods of analysis, principally fluorescence spectroscopy and spectral comparisons with model compounds.

One of the unique properties of PAH's is their intense fluorescence; indeed, it was this property alone that allowed Cook and co-workers to isolate benzo(a)pyrene from coal tar.¹¹ Furthermore, the fluorescence spectrum of the hydrocarbon is primarily a function of its π -system; an alkyl-substituted aromatic hydrocarbon will have essentially the same fluorescence excitation and emission spectra as the parent compound, with only a minor shift (ca. 6nm) to longer wavelengths. With a modern spectrofluorometer, it is possible to obtain a corrected fluorescence spectrum on as little as 1 ng of material. This selectivity and sensitivity immediately suggested fluorescence spectroscopy as an analytical tool for investigating the structure of the BaP-poly(G) complex.

The corrected fluorescence excitation and emission spectra of benzo(a)pyrene are shown in Figure 1a; spectra of the isolated BaP-poly(G) adduct are shown in Figure 1b and 1c (see "Experimental" for a discussion of the various hydrolysis procedures). Since metabolism by microsomal enzymes is required for formation of this adduct, the metabolic scheme outlined in Figures 1 and 2 of Chapter 1 should have some relevance to the presumed metabolic activation of benzo(a)pyrene that takes place prior to binding. Metabolism at a particular bond of the hydrocarbon should result in a spectral change characteristic of the modified aromatic system. For example, metabolism at the 4,5-bond of BaP and subsequent binding of a nucleophile at that position should result in a chrysene-like spectrum, easily distinguishable from that of BaP:

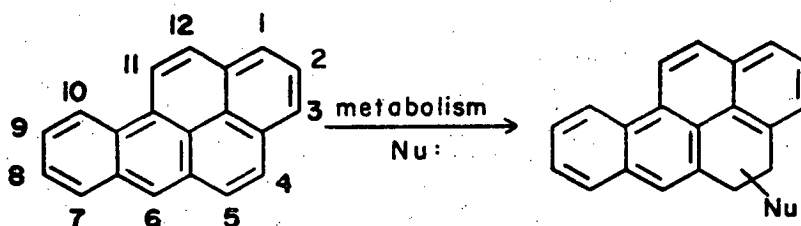

An example of this is seen in Figure 2, where the fluorescence spectra of chrysene and cis-4,5-dihydroxydihydrobenzo(a)pyrene are represented. A comparison with Figure 1a demonstrates that the 4,5-substituted benzo(a)pyrene is easily distinguished from that of the parent compound and has a red-shifted chrysene-like spectrum. Thus identification of the binding sites on the hydrocarbon should be possible by comparing the fluorescence excitation and emission spectra of the BaP-poly(G) complex with those of a number of reduced benzo(a)pyrene derivatives. This, of course, assumes that metabolism of a given π -bond results in

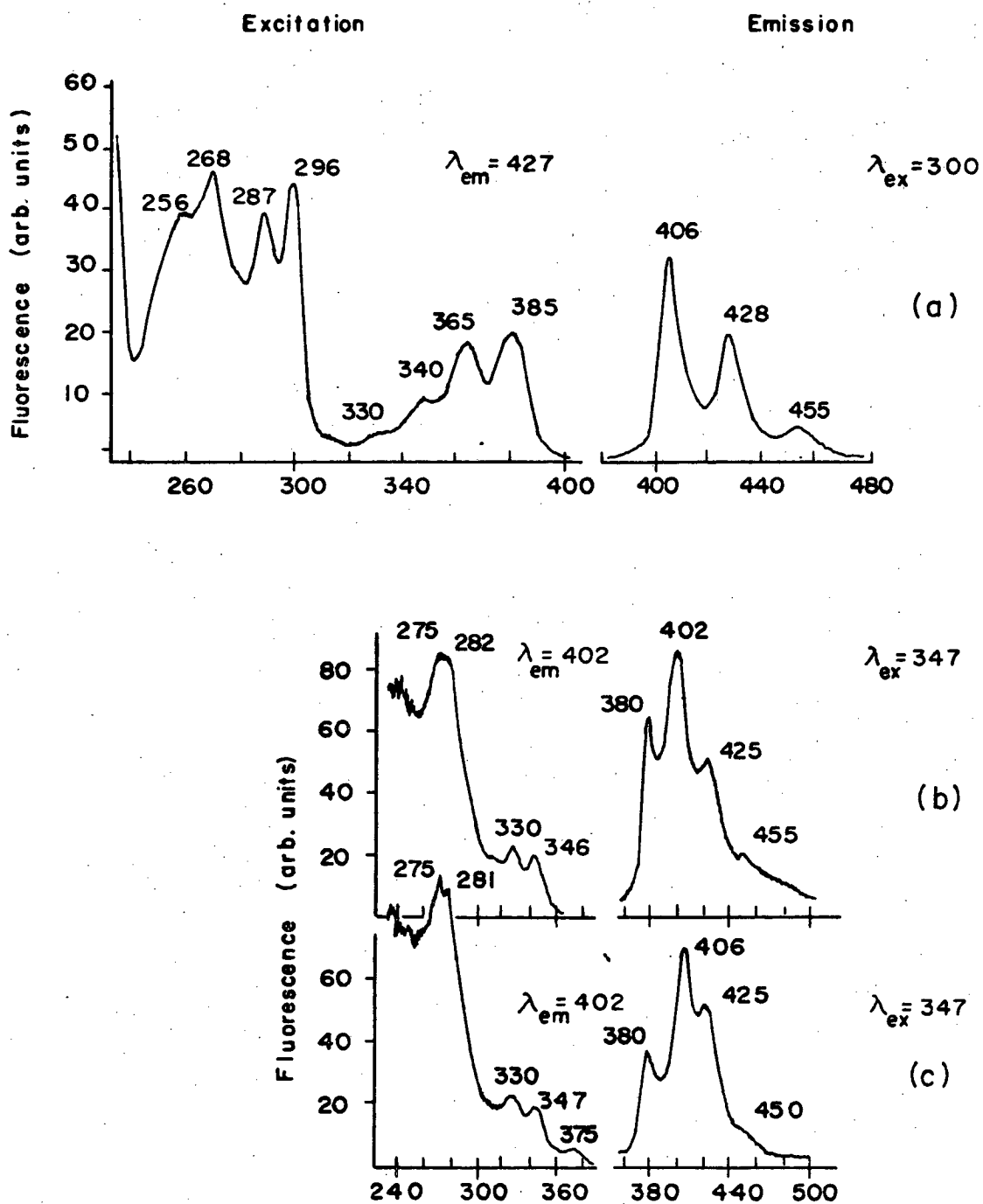

Figure 1: Fluorescence spectra of (a) benzo(a)pyrene, 7.42×10^{-7} M; (b) enzyme-hydrolyzed BaP-poly(G) complex; (c) NaOH-hydrolyzed BaP-poly(G) complex. Solvent: ethanol; em. 10 x ex. scale.

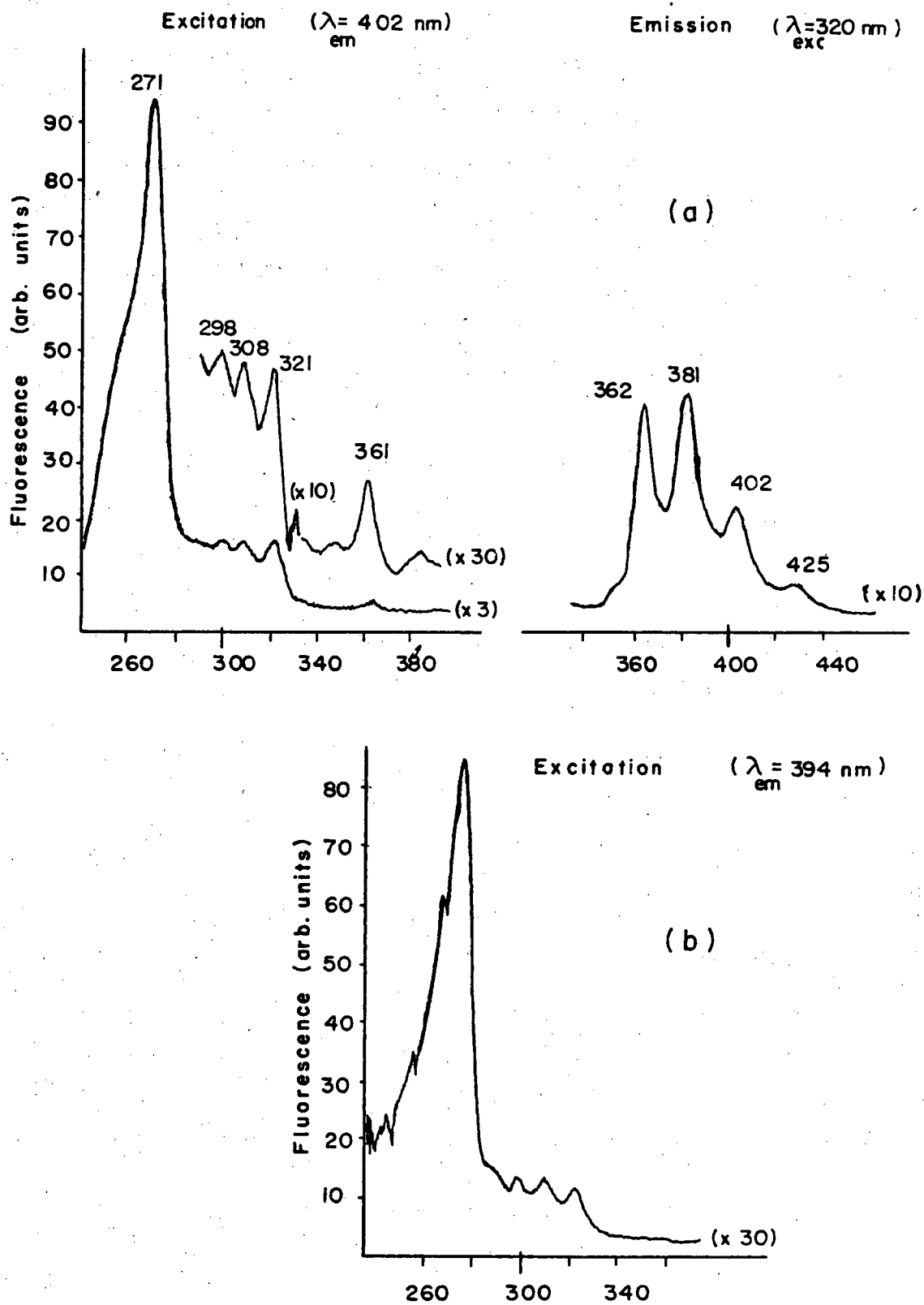

Figure 2: Fluorescence spectra of (a) chrysene, $1 \times 10^{-6} \text{ M}$
(solvent: ethanol) (b) cis-4,5-dihydroxy-dihydroBaP
($1.01 \times 10^{-6} \text{ M}$)

the removal of that bond from interaction with the remaining aromatic system; subsequent rearomatization could occur; in which case the spectrum would resemble that of benzo(a)pyrene. Conjugation with a chromophore present on the nucleophile could also occur, resulting in a perturbed spectrum of some sort. Another possibility is that oxidation of the aromatic system could occur to generate a quinone-type structure (the benzo(a)pyrene-quinones that have been studied have very low quantum yields for fluorescence relative to the parent hydrocarbon).

As Figure 1 demonstrates, the fluorescence excitation and emission spectra of the BaP-poly(G) complex are easily distinguishable from that of benzo(a)pyrene; they do, however, resemble that of a red-shifted pyrene. The spectra of a number of partially reduced benzo(a)-pyrene chromophores are represented in Figure 3a-3e; comparison of these spectra with those of Figure 1 shows that the BaP-poly(G) adduct and 7,8,9,10-tetrahydrobenzo(a)pyrene have nearly identical excitation and emission spectra. The spectra of the other derivatives are easily distinguishable from each other and from that of the BaP-poly(G) adduct. Absorbance spectra of 7,8,9,10-tetrahydrobenzo(a)pyrene, cis-7,8-dihydroxy-7,8,9,10-tetrahydrobenzo(a)pyrene, and the BaP-poly(G) adduct are shown in Figure 4a-c, and correspond very closely to each other. Results similar to these were obtained on in vivo bound benzo(a)pyrene by Daudel et al.⁴⁷ (using a photon-counting technique) and by Weinstein et al.⁴⁸ (using low-temperature fluorescence) at about the same time. These results indicate that metabolism at the 7,8,9 and 10-positions of the hydrocarbon has occurred during the enzyme-mediated binding.

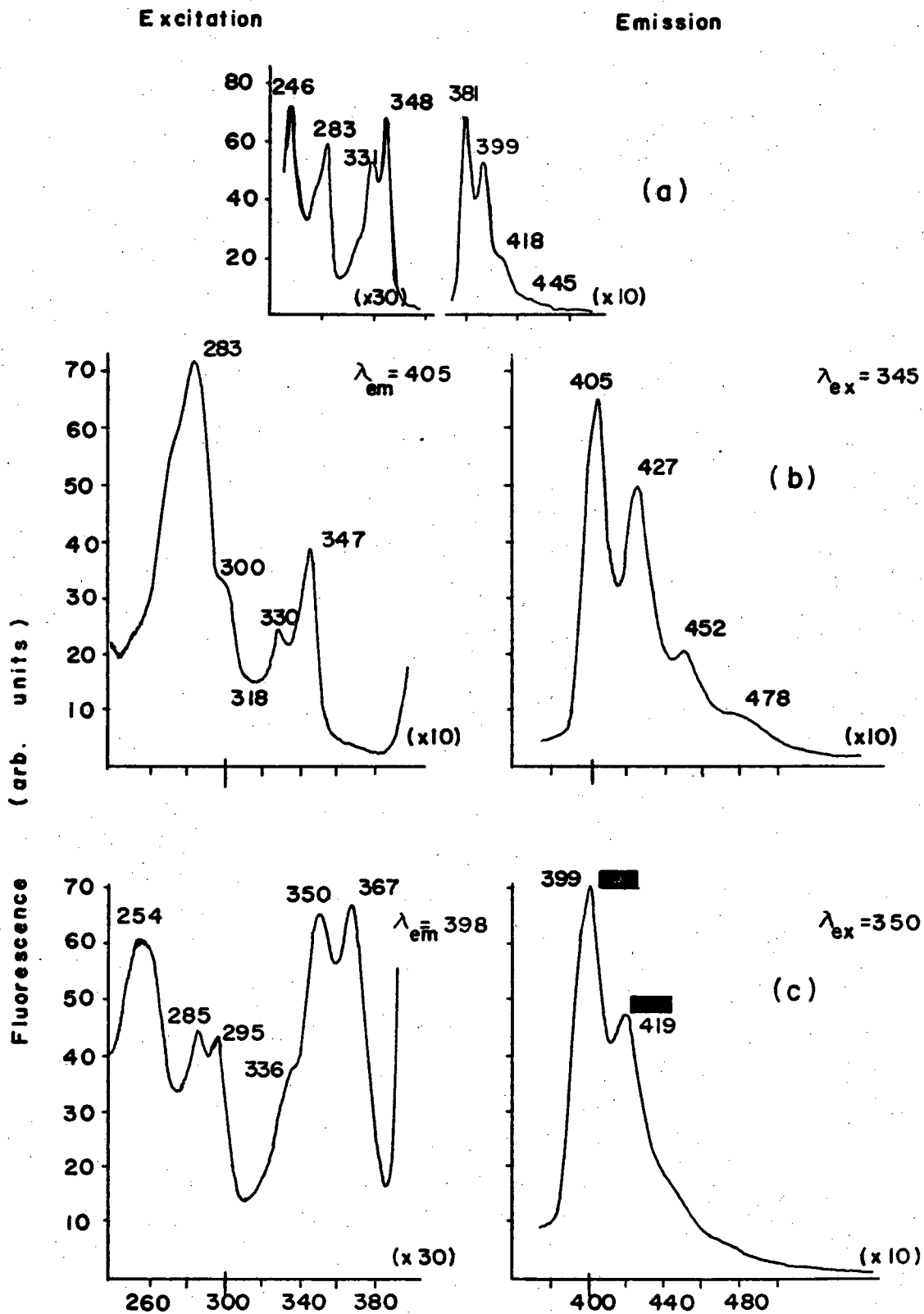

Figure 3: (a) 7,8,9,10-tetrahydroBaP, 3.40×10^{-7} M; (b) 9,10-dihydroBaP, 6.19×10^{-7} M; (c) 7,8-dihydroBaP, 1.64×10^{-7} M [ethanol].

Figure 3: Fluorescence spectra of (d) 10-hydroxy-7,8,9,10-tetrahydrobenzo(a)pyrene, 3.24×10^{-7} M in ethanol (em 10x ex scale).

(e) NaOH-hydrolyzed BaP-poly(G) products, treated with HCl (0.1N/ 37°/ 1 hr.), in 50% ethanol-water (em 3.33x ex scale).

Figure 4: Absorbance spectra of (a) 7,8,9,10-tetrahydrobenzo(a)pyrene, 1.75×10^{-5} M in ethanol.

(b) cis-7,8-dihydroxy-7,8,9,10-tetrahydrobenzo(a)pyrene, 2.95×10^{-5} M in ethanol.

(c) enzyme-hydrolyzed BaP-poly(G) products, in 50% ethanol-water.

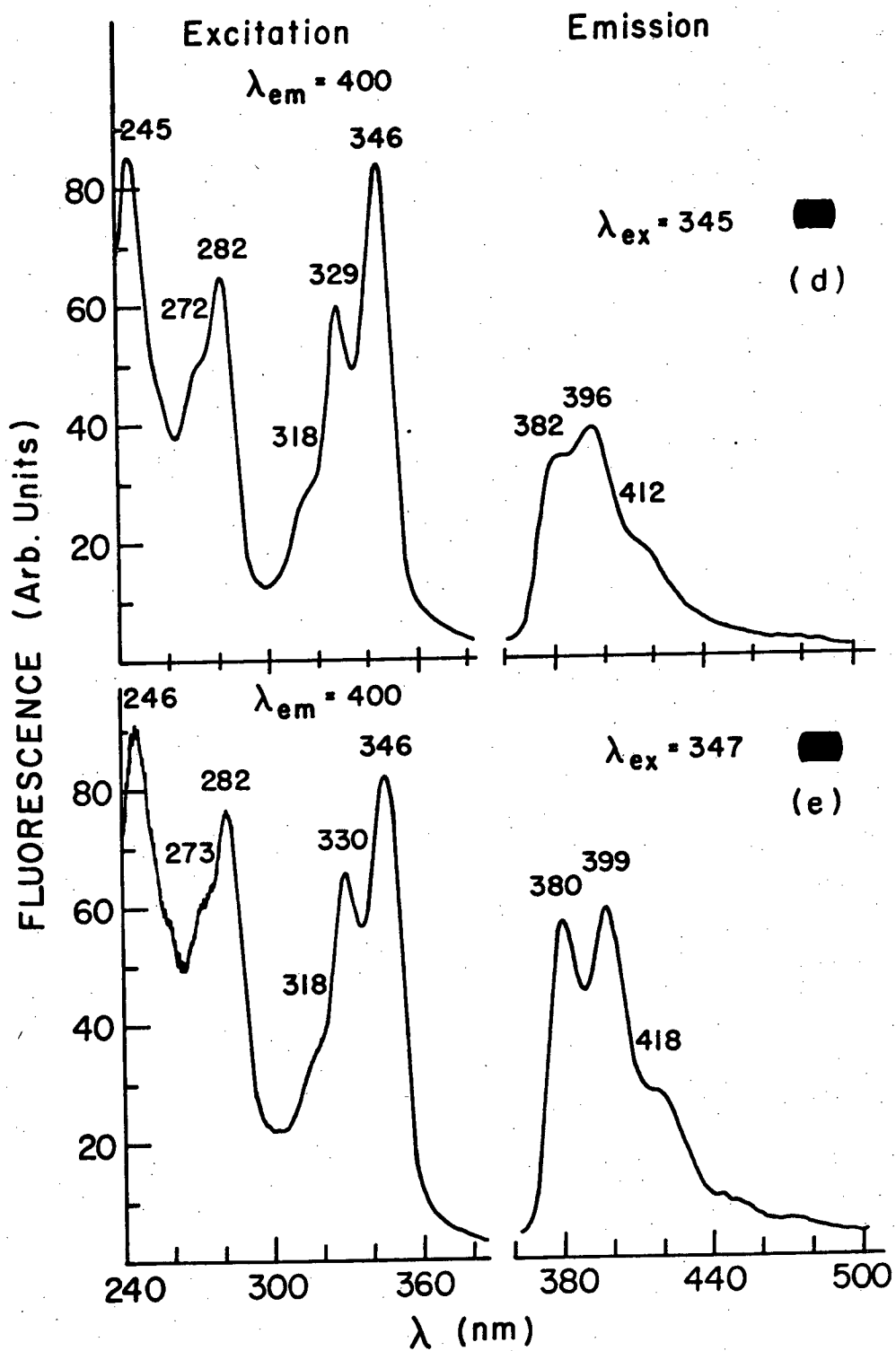
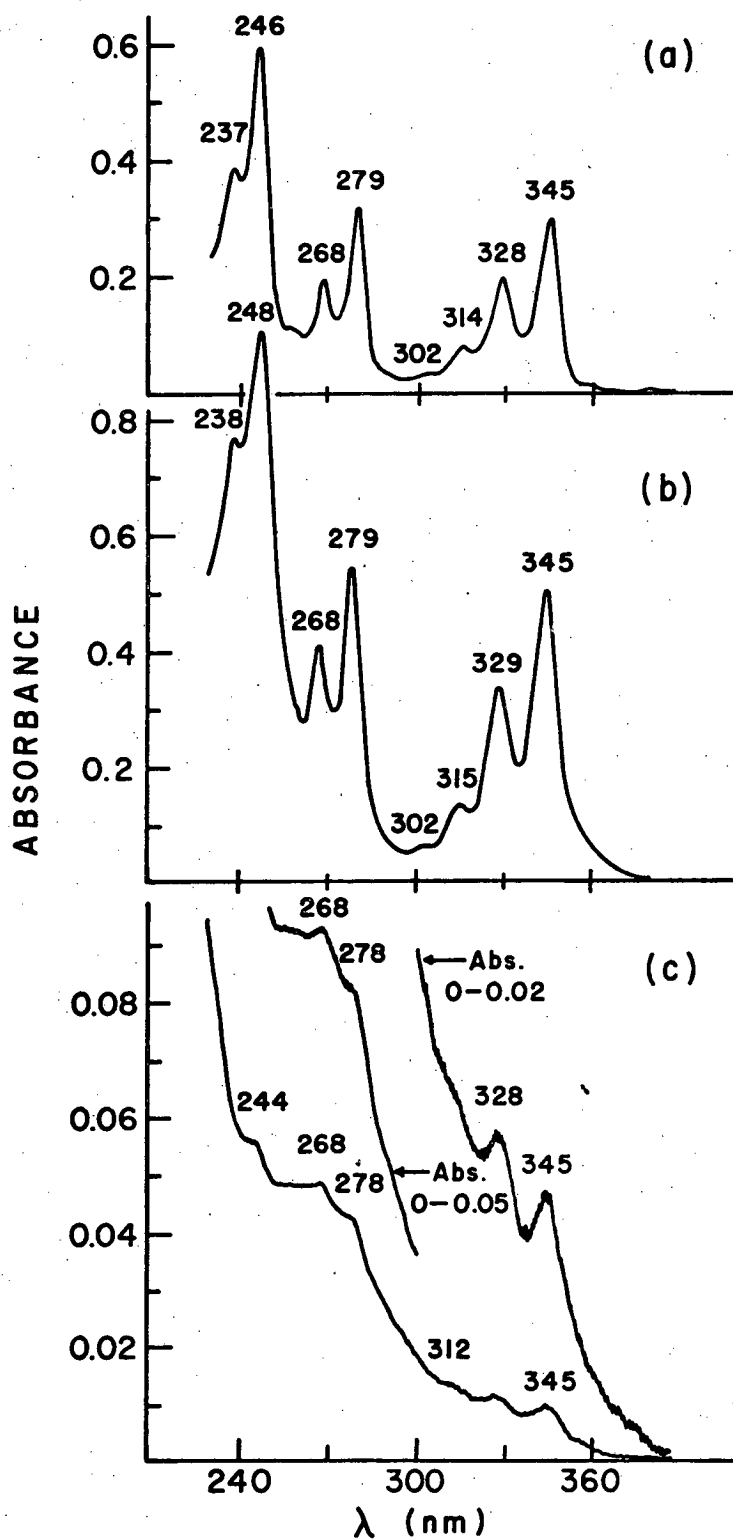

Figure 3 d, e

XBL7512-8789



XBL7512-8794

Figure 4

The enzyme-hydrolyzed BaP-poly(G) adduct was shown by Meehan et al. to be sensitive to treatment by alkaline phosphatase (see "Experimental"), suggesting that the hydrocarbon was covalently attached to the ribonucleotide.⁴⁴ However, there is no evident contribution from the nucleotide to the fluorescence or absorbance spectra of the adduct. This is presumably because of the low fluorescence intensity generally found for purine or pyrimidine nucleotides; any contribution to the total fluorescence spectrum is small relative to the contribution from the hydrocarbon. Similarly, one would expect a negligible contribution from the ribonucleotide to the absorbance spectrum, since its ϵ_{max} is less than 10% of that of a chromophore such as 7,8,9,10-tetrahydrobenzo(a)pyrene (see Chapter 3). Also, the relatively featureless absorption spectrum of guanosine would be expected to change only the relative intensities of the absorption bands in a spectrum like that of 7,8,9,10-tetrahydrobenzo(a)pyrene, but not to alter the overall pattern. Comparison of a number of substituted 7,8,9,10-tetrahydrobenzo(a)pyrene derivatives showed that all exhibited the same basic spectra. The structure of the adduct can therefore be represented as

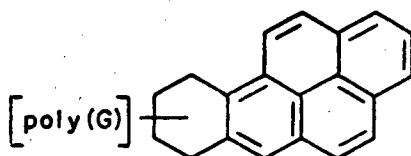

As discussed in Chapter 1, metabolism of benzo(a)pyrene by microsomal enzymes is known to involve ring epoxidation and hydroxylation. Since only picomolar quantities of the BaP-poly(G) adduct were availa-

ble for study, we attempted to use a chemical probe along with fluorescence spectroscopy to investigate the nature of the substituents on the hydrocarbon moiety of the adduct. The probe we chose to utilize was acid-catalyzed dehydration; any resulting changes in the nature of the aromatic chromophore could be monitored by fluorescence spectroscopy. If hydroxyls occur at the 7,8,9, or 10- positions of the tetrahydro-BaP moiety, acid-catalyzed dehydration could result in a number of possibilities: (1) a single hydroxyl at positions 7 or 10 would be expected to undergo dehydration and yield either 7,8-dihydrobenzo(a)pyrene or 9,10-dihydrobenzo(a)pyrene, respectively; (2) a

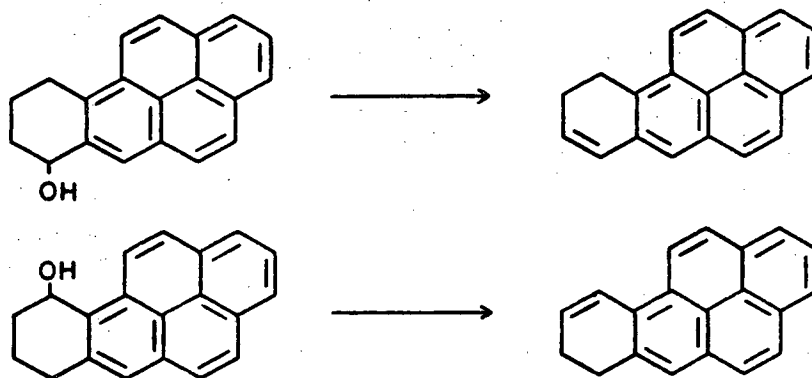

dihydroxyl at positions 7,8 or 9,10 would be expected to yield 8- or 9-oxo-7,8,9,10-tetrahydrobenzo(a)pyrene (see below); (3) a tri- or tetrahydroxy derivative might be expected to result in a fully aromatized benzo(a)pyrene chromophore. Dehydration reactions were carried out in either ethanol or benzene using p-toluenesulfonic acid (p-TsOH) as the reagent. With model systems, this reagent was found to give clean reaction products. A series of model compounds was investigated first to test the above predictions and confirm whether or not such an approach was feasible.

Dehydration of 7-hydroxy-7,8,9,10-tetrahydrobenzo(a)pyrene under these conditions resulted in exclusive formation of 9,10-dihydrobenzo(a)pyrene, confirmed by its unique fluorescence spectrum as well as by analysis of the reaction products with HPLC and mass spectrometry. Similarly, 10-hydroxy-7,8,9,10-tetrahydrobenzo(a)pyrene gave only 7,8-dihydrobenzo(a)pyrene as the reaction product. These results confirm prediction (1), above. Dehydration of cis-9,10-dihydroxy-7,8,9,10-tetrahydrobenzo(a)pyrene gave mainly 9-oxo-7,8,9,10-tetrahydrobenzo(a)pyrene, with no evidence of any 10-oxo isomer (the unique fluorescence spectrum of 10-oxo-7,8,9,10-tetrahydrobenzo(a)pyrene is shown in Figure 7b). Dehydration of cis-7,8,-dihydroxy-7,8,9,10-tetrahydrobenzo(a)pyrene gave predominantly 8-oxo-7,8,9,10-tetrahydrobenzo(a)pyrene, along with a small amount (<5%) of 7-oxo-7,8,9,10-tetrahydrobenzo(a)pyrene (identified by HPLC retention time and mass spectrometry of the isolated material). Formation of the 7-oxo-isomer but not the 10-oxo compound is presumably due to the difference in benzylic carbonium ion stability between the 7- and 10-positions of the tetrahydrobenzo(a)pyrene. Molecular orbital calculations predict greater stabilization by the aromatic system of a carbonium ion at C-10 than at C-7.⁴⁹ This situation leads to exclusive formation of 9-oxo-7,8,9,10-tetrahydrobenzo(a)pyrene by a 1,2 hydride shift. The decreased stabilization of a benzylic carbonium ion at C-7 in the case of the 7,8-dihydroxy compound results in the formation of a small amount of 7-oxo isomer:

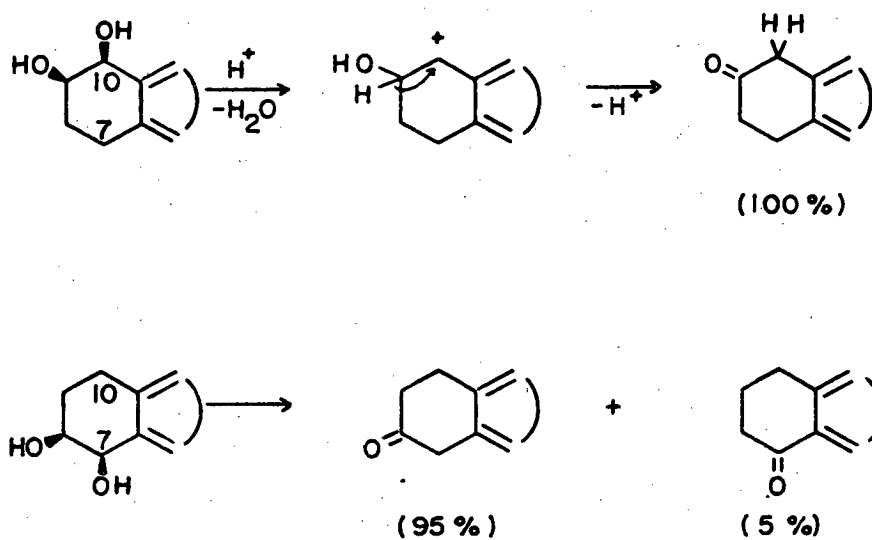

Figure 5 shows the fluorescence spectra obtained by dehydration of the cis-7,8-diol. The presence of the 7-oxo dehydration product is indicated by the small relative maxima at 478 nm and at 498 nm. HPLC of this reaction mixture and mass spectrometry of the products confirmed the presence of 7-oxo-7,8,9,10-tetrahydrobenzo(a)pyrene. Dehydration of the BaP-poly(G) adduct under identical conditions resulted in the fluorescence spectra shown in Figure 6b. The similarity to the results obtained with dehydration of cis-7,8-dihydroxy-7,8,9,10-tetrahydrobenzo(a)pyrene is striking, and suggests that hydroxyls are present at positions 7- and 8- of the hydrocarbon. Since epoxides were known to be intermediates in the metabolism of PAH's, this dihydroxyl functionality could have arisen by hydrolysis of an epoxide at the 7,8-positions of the hydrocarbon. The nucleotide residue is then presumably linked to C-9 or C-10; a single hydroxyl at C-10 is not indicated since such a species would be expected to dehydrate to a fully aromatized benzo(a)pyrene chromophore. However, the lack of a suitable model compound (tri- or tetrahydroxy-7,8,9,10-

Figure 5: Fluorescence spectra of (a) cis-7,8-dihydroxy-7,8,9,10-tetrahydrobenzo(a)pyrene, 1.67×10^{-7} M in ethanol; em 3.33 x ex scale.

(b) 7-oxo-7,8,9,10-tetrahydrobenzo(a)pyrene, 1.85×10^{-6} M in ethanol; em 10x ex scale.

(c) emission spectrum of tosic-acid (pTsOH)-dehydrated cis-7,8-dihydroxy-7,8,9,10-tetrahydrobenzo(a)pyrene after LH20 chromatography.

Figure 6: Fluorescence spectra of (a) 7-oxo-7,8,9,10-tetrahydrobenzo(a)pyrene isolated by HPLC from dehydration of cis-7,8-dihydroxy-7,8,9,10-tetrahydrobenzo(a)pyrene (em 3.33x ex scale).

(b) NaOH-hydrolyzed BaP-poly(G) complex after dehydration with pTsOH, as described in "Experimental" (em 10x ex scale).

Figure 7: Fluorescence spectra of (a) 8-oxo-7,8,9,10-tetrahydrobenzo(a)pyrene, 1.40×10^{-6} M in ethanol (em 3.33x ex scale).

(b) 10-oxo-7,8,9,10-tetrahydrobenzo(a)pyrene, 3.61×10^{-6} M in ethanol (em 3.33x ex scale).

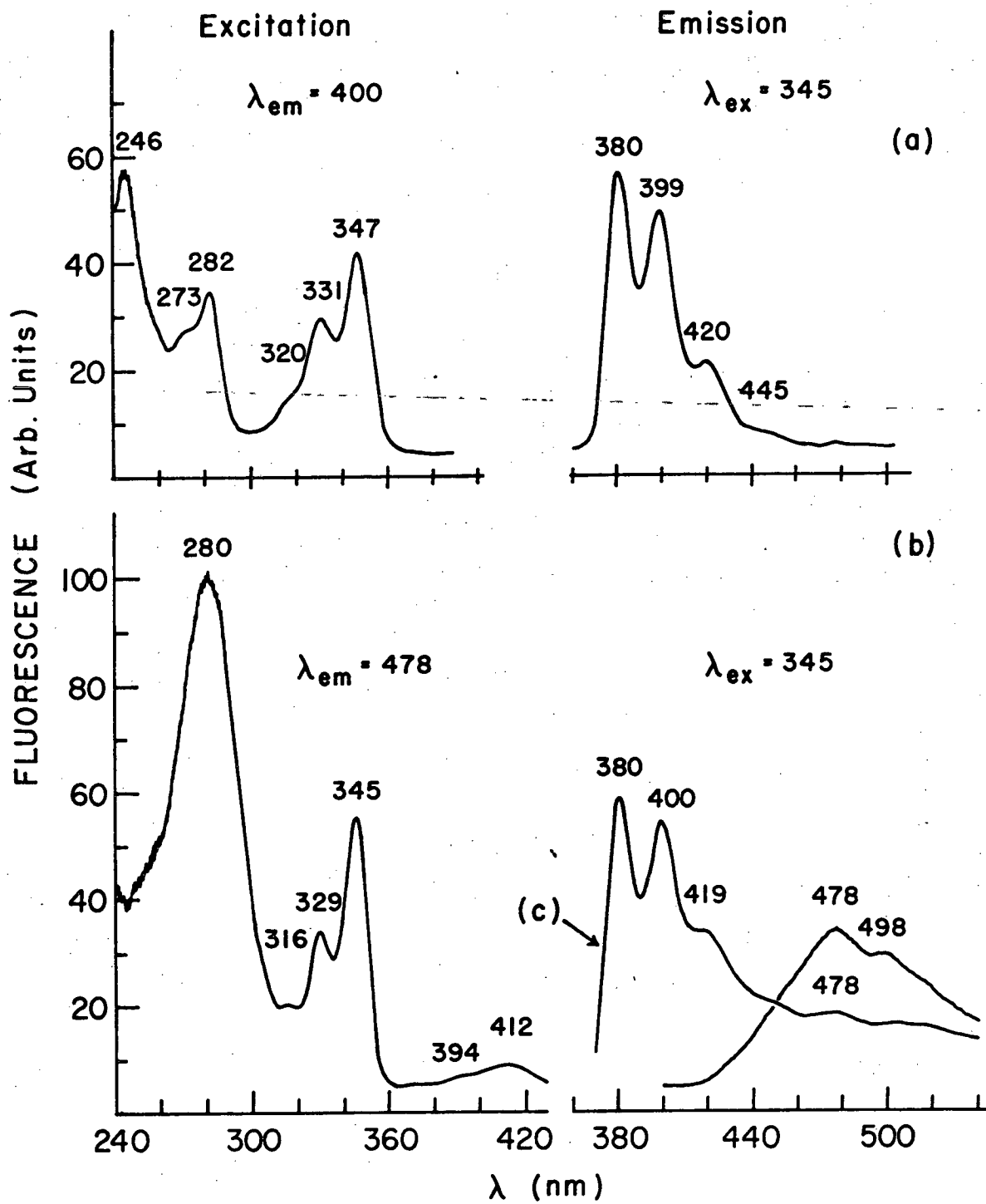
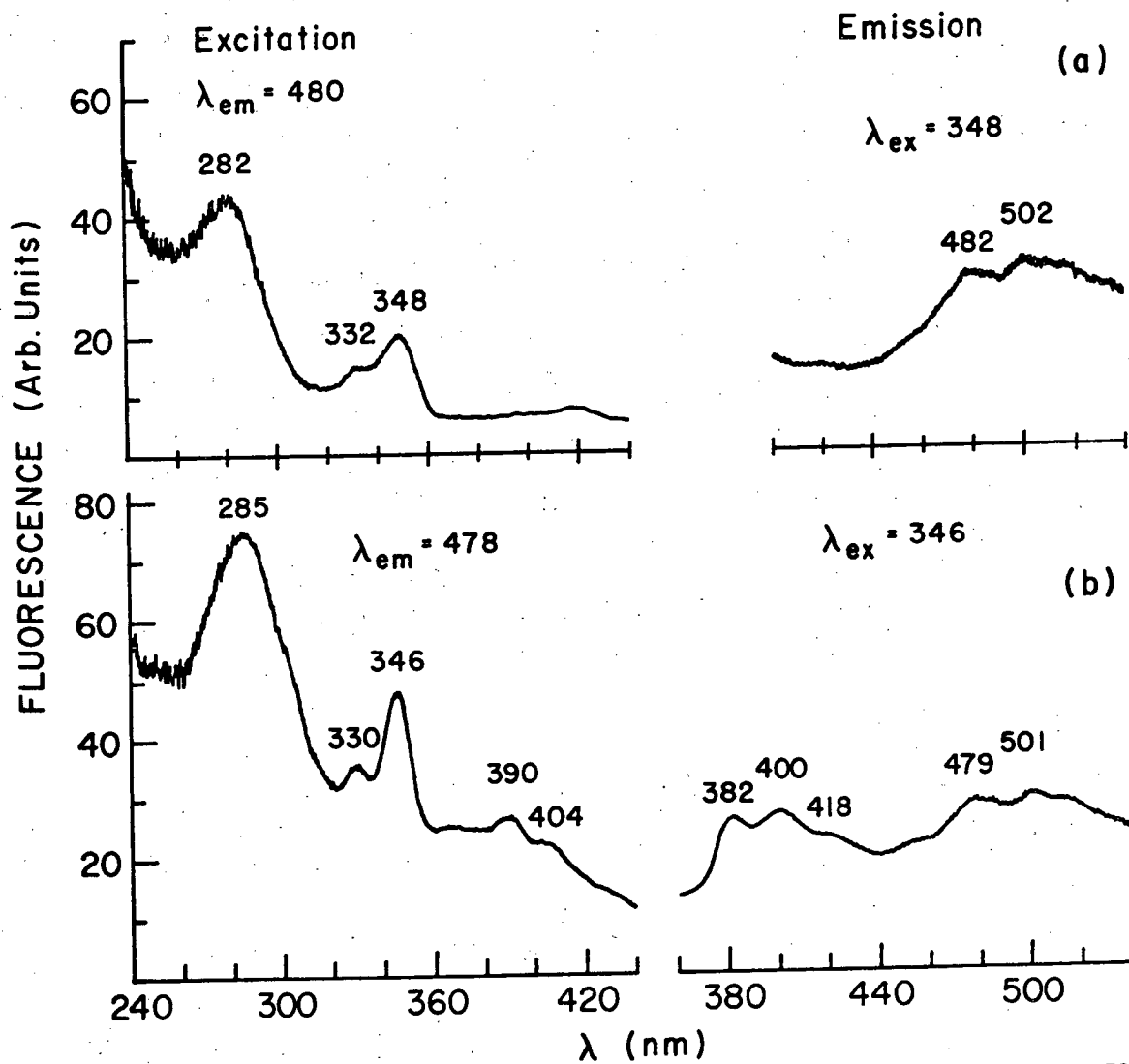

Figure 5

XBL7512-8791



XBL7512-8792

Figure 6

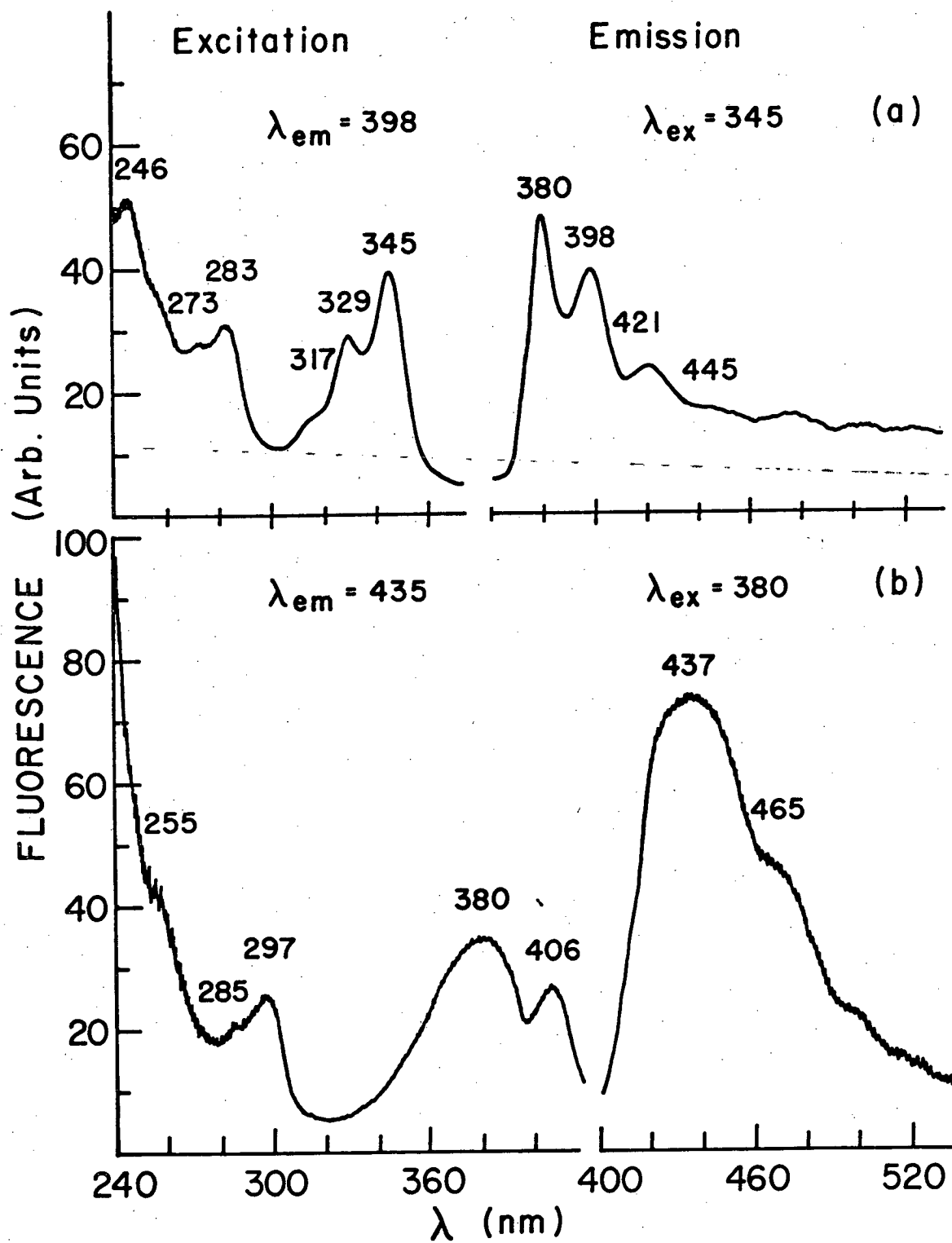

XBL7512-8788

Figure 7

tetrahydrobenzo(a)pyrene) to test this hypothesis meant that we really had no information about the substituents at C-9 or C-10. Our hypothetical structure, then, can be represented as

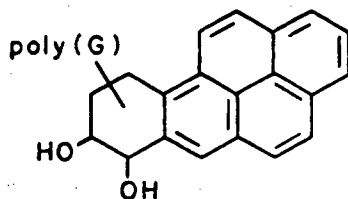

It must be emphasized that this type of study was designed to provide preliminary evidence about the nature of the hydrocarbon metabolite involved in covalent binding to poly(G). The extremely low quantities of adduct available for analysis ruled out other, more direct techniques. The presence of a 7,8,9,10-tetrahydrobenzo(a)-pyrene chromophore is indicated, although the evidence for hydroxyls at positions 7 and 8 is not as definitive (the substituents could in fact be other acid-labile leaving groups). Also, the adduct as isolated could well consist of a number of components; the only criterion of purity we had was that the emission spectrum of the complex was the same irrespective of the excitation wavelength, and that the excitation spectrum did not vary with emission setting. Thus the possibility that more than one compound was present with identical fluorescence spectra could not be ruled out.

Parallel investigations into the metabolism of PAH's with both microsomal systems⁵⁰⁻⁵⁴ and with cultured cell lines⁵⁵ had at this point identified a large number of primary and secondary metabolites. These included dihydrodiols, phenols, quinones, and arene oxides. Table 1 lists a number of known benzo(a)pyrene metabolites:

Table 1
Identified Benzo(a)pyrene Metabolites

Metabolite	Reference
<u>trans</u> -7,8-dihydrodiol	50, 51, 53
<u>trans</u> -9,10-dihydrodiol	50, 51, 53, 55
<u>trans</u> -4,5-dihydrodiol	50, 51, 53
4,5-oxide	50
1,6-quinone	50, 51, 53, 55
3,6-quinone	50, 51, 53, 55
6,12-quinone	50, 51, 53, 55
phenols (exact number unknown)	50, 51, 53, 55
glutathione conjugates (uncharacterized)	56
glucuronic acid conjugates (uncharacterized)	57

An important line of research undertaken at this time was cytotoxicity and mutagenesis testing of known or potential metabolites of benzo(a)pyrene. Only the K-region 4,5-oxide was found to be mutagenic in bacterial tester systems.⁵⁸ Similar studies with metabolites of 7,12-dimethylbenz(a)anthracene and 7-methylbenz(a)anthracene yielded identical results: only the K-region oxides had appreciable mutagenic activity.⁵⁹ It was found, however, that the RNA-nucleoside adducts obtained from cells exposed to the parent hydrocarbon did not co-chromatograph with the nucleoside adducts obtained by reacting RNA with K-region oxides in vitro.⁶⁰ At this point two key experiments involving benzo(a)pyrene primary metabolites were performed. Borgen et al. monitored the in vitro binding of these metabolites to DNA, with

negative results for all compounds (except the 4,5-oxide).⁶¹ But when binding of these metabolites in the presence of the NADPH-microsomal incubation system was monitored, it was found that the 7,8-dihydrodiol possessed high binding activity. That is, it appeared that further metabolism of the primary metabolites was necessary in order for binding to DNA in vitro to occur. A second set of critical experiments was carried out by Conney et al., who monitored mutagenic activity of the primary benzo(a)pyrene metabolites in the presence of the microsomal incubation system.⁶² It was found that the 7,8-dihydrodiol had high mutagenic activity when tested in this fashion; a number of other metabolites (including 9-hydroxybenzo(a)pyrene) also showed greatly enhanced activity. This data correlated with the results obtained in the fluorescence study of the BaP-poly(G) complex--our preliminary evidence suggested the presence of hydroxyls at C-7 and C-8, which is compatible with a 7,8-dihydrodiol as a precursor to a DNA-binding species. The fluorescence data also indicated the presence of a fully reduced benzo-"A" ring. This suggested that the active DNA-binding species generated from the 7,8-dihydrodiol involved metabolism of the 9,10-bond:

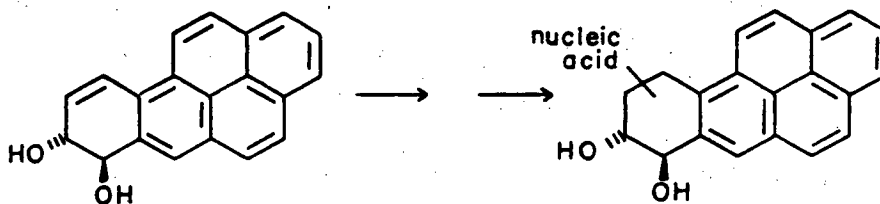

Since the P-448-containing microsomal enzyme mixture was required for activation of the 7,8-dihydrodiol, the most likely active species that could be generated in this system is a 7,8-dihydroxy-9,10-epoxide:

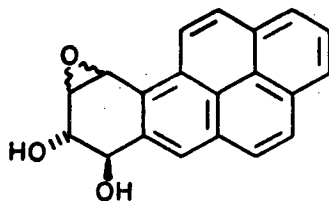

Sims and coworkers arrived at a similar conclusion:⁶³ they trapped out metabolically formed [$G-^3H$]-7,8-dihydrodiol, oxidized this material with *m*-chloroperbenzoic acid to an uncharacterized product (presumably containing a diol epoxide of undefined stereochemistry) and incubated it with DNA *in vitro*. This modified DNA was then enzymatically digested, and the products compared chromatographically with DNA obtained from primary hamster embryo cells which were exposed to ^{14}C -benzo(a)pyrene. The 3H -diol/DNA products were observed to co-chromatograph with the ^{14}C -BaP/DNA products on Sephadex LH20 (a lipophilic, dextran-based gel). These results, together with the fluorescence studies described above, strongly implicated a diol epoxide-type compound as an active DNA-binding species. As described in Chapters 3-5, the high mutagenic activity found for the synthetic diol epoxides fully supported this idea. We therefore undertook a research effort to synthesize the diol epoxides of benzo(a)pyrene and compare the products obtained by modifying DNA with synthetic diol epoxide and microsome-activated benzo(a)pyrene. A report of the results of this effort is contained in Chapters 3-6.

Experimental

Chemicals. Sephadex LH20 was obtained from Pharmacia (Piscataway, New Jersey). Ribonuclease T₁ (EC 3.1.4.8), bovine spleen phosphodiesterase type I, alkaline phosphatase (EC 3.1.3.1), poly (G), and NADPH were supplied by Sigma (St. Louis, Missouri). 3-Methylcholanthrene was purchased from Calbiochem (La Jolla, California) and used without further purification. Benzo(a)pyrene was obtained from Aldrich (Milwaukee, Wisconsin) and further purified by chromatography on Woelm Grade 1 neutral alumina, using benzene as eluant, and followed by recrystallization from benzene-isopropanol. HPLC solvents were obtained from Burdick and Jackson Laboratories (Muskegan, Michigan). [G-³H] benzo(a)pyrene (1-5 cc/mmol) was obtained from Amersham-Searle (Arlington Heights, Illinois).

Microsomes. Male Sprague-Dawley rats (Simonsen Laboratories, Gilroy, California) weighing approximately 200 g were given 3-methylcholanthrene in corn oil by intraperitoneal injection at a dose of 25 mg/kg body weight, forty-eight hours before sacrifice. Animals were sacrificed by decapitation and the livers were immediately removed and chilled in ice-cold 0.9% NaCl. Subsequent operations were carried out at 4°. The tissue was minced, suspended in two volumes Tris-sucrose buffer (0.05 M Tris-base, 0.25 M sucrose, 0.1 mM dithiothreitol at pH 7.5), and a cell extract was prepared with a glass-Teflon tissue homogenizer. The extract was then centrifuged at 1500 x g for ten minutes, 10,000 x g for thirty minutes, and finally at 100,000 x g for ninety minutes. This 100,000 x g pellet was dispersed in Tris-sucrose buffer at a protein concentration of 16 mg/ml, and stored at -70°.

Analytical Procedures. Protein concentration was determined by the method of Lowry with bovine serum albumin as reference standard. Counting of ^3H was carried out on a Packard liquid scintillation spectrometer (model 3380). Efficiency quench curves were constructed with the use of sealed standards. Samples were counted in solution or as a gel, using Aquasol-2 as a cocktail (New England Nuclear, Boston, Massachusetts). High pressure liquid chromatograph (HPLC) was carried out with a Varian model 8500 liquid chromatograph (Walnut Creek, California) using reverse phase (octadecyl silane) columns (Micropak CH-10, 25 cm x 2.1 mm), eluted at room temperature with water-methanol. A standard flow rate of 1 ml/min. was used, and the effluent monitored for absorbance at 254 nm.

[G- ^3H] BaP-poly(G) Complex. Formation, hydrolysis, and isolation of the covalently linked [G- ^3H] BaP-poly(G) complex was essentially as described previously by Meehan *et al.*⁴⁴ The standard reaction contained 6 nmol of benzo(a)pyrene (ca. 1 μCi total after dilution), 500 μg poly(G), 0.45 μmol NADPH, 400 μg microsomal protein, and 20 μl ethanol in a total volume of 1.5 ml of 0.01 M phosphate buffer (pH 7.5). Assays were incubated at 37^o for thirty minutes, and the reaction stopped by addition of 3 ml of phenol reagent (500 ml phenol, 70 ml m-cresol, 50 ml water, 0.5 g 8-hydroxyquinoline); NaCl was added to bring the assay concentration to 0.1 M and the sample volume to 2 ml. The samples were extracted by the method of Leaver and Key. The phenol phase was extracted with 2 ml of 0.01 M phosphate buffer (pH 7.5); the aqueous phases were then combined and extracted twice with one volume of ethyl acetate. Two volumes of ethanol were then added to the aqueous phase and the sample immersed in a boiling water bath

for ten minutes. The poly(G) precipitate was then collected by centrifugation (ca. 10,000 x g), redissolved in 0.1 M NaCl, and the ethanol procedure repeated. The final precipitate was then taken up in 0.01 M phosphate buffer (pH 7.51) and analyzed for radioactivity. Assays were scaled up twenty-fold for hydrolysis and chromatographic analyses. Typical binding levels using this procedure were 125 ± 10 pmol BaP bound per 500 μ g poly(G). Assuming a molecular weight of ~ 500 for the monomeric adduct, this would correspond to ca. 60 ng of BaP-poly(G) adduct per standard assay.

Hydrolysis. The phosphodiester linkages of poly(G) were hydrolyzed either enzymatically or chemically. Enzymatic hydrolyses were carried out at 37⁰ in 0.1M tris buffer (pH 7.5) 2 mM in EDTA. The BaP-poly(G) complex was first treated for three to six hours with ribonuclease T₁ (10,000 units per mg of poly(G)), followed by additional ribonuclease T₁ and spleen phosphodiesterase (0.3 units per mg nucleic acid) for twenty to twenty-four hours. The pH of the solution was then adjusted to 8.5 with NaOH and alkaline phosphatase (10 units/mg poly(G)) added to remove the 3'-monophosphate. Chemical hydrolysis of the poly(G) complex was carried out with 0.1 M NaOH at 37⁰ for twenty to twenty-four hours.

The chemical or enzymatic digest was then applied to a micro (1 x 5 cm) Sephadex LH20 column, eluted with one column volume of water followed by one column volume of methanol. The radioactive material which eluted with methanol was then analyzed by thin layer chromatography (silica gel G eluted with butanol-acetone-water (60:38:2 v/v/v). The ³H-containing band (fractions of the TLC plate were scraped and counted as a gel) was then analyzed by fluorescence

spectroscopy, as well as by HPLC.

Spectroscopy. Corrected fluorescence spectra were recorded on a xenon source spectrophotofluorometer (Perkin Elmer, Model MPF-3, Norwalk, Connecticut). The instrument automatically records corrected excitation and emission spectra (intensity versus wavelength variations due to source, monochromators, and detectors are eliminated) by signal ratioing between sample and reference (rhodamine B) channels. Anthracene was used to test the correction. Spectra were recorded under the following conditions: (i) band pass 10 nm (slit width 1.29 mm) for both excitation and emission scans; (ii) path lengths: excitation 10 mm and emission 3 mm; (iii) absorbance < 0.05 at all excitation wavelengths; (iv) self-absorption effects not observed; (v) temperature, 25^o; (vi) samples equilibrated with air; and (vii) solvents, redistilled ethanol and/or distilled deionized water.

Absorption spectra were recorded on a Cary model 118 (Cary/Varian, Palo Alto, California) spectrophotometer.

Dehydration Reactions. Samples were treated with a large (ca. 100 molar equivalents) excess of p-toluenesulfonic acid in dry ethanol at 70^o for sixteen-twenty hours; the acid was removed by LH20 column chromatography. Alternatively, the reaction was carried out in benzene and the acid removed by extraction with buffer. Solvents were evaporated in vacuo and the residue taken up in ethanol or 50% ethanol-water for fluorescence assay.

The large excess of p-TsOH was used because only picomolar quantities of the BaP-poly(G) adduct was available for analysis. Model compounds described in the discussion were analyzed where necessary by HPLC, before and after treatment with p-TsOH. For example, in the

dehydration of cis-7,8-dihydroxy-7,8,9,10-tetrahydrobenzo(a)pyrene, both 8-oxo-7,8,9,10-tetrahydrobenzo(a)pyrene (95%) and 7-oxo-7,8,9,10-tetrahydrobenzo(a)pyrene were detected by collecting the eluted material and comparing it with synthetic standard by absorption, fluorescence, and mass spectra, as well as by HPLC (coinjection) with standard. See Chapter 3 for a discussion of the synthetic standards.

Chapter 3: Synthesis of Benzo(a)pyrene Derivatives

The fluorescence spectral and dehydration studies on the isolated poly(G)-BaP complex indicated to us the importance of developing synthetic approaches to 7,8,9,10-substituted derivatives of benzo(a)pyrene. The discussion in Chapter 2 describes a number of synthetic derivatives of benzo(a)pyrene; an explanation of the synthetic methodology behind them has been delayed until now. Synthetic approaches to the polycyclic aromatics can be broadly divided into two categories--those directed towards synthesis of the parent hydrocarbon, and those directed towards synthesis of potential metabolites (oxides, diols, phenols, etc.) of the hydrocarbon. Interest in the latter category has been relatively recent, with the majority of experimental work taking place from 1973 to the present.

During the period 1930-1950 a major effort was made in developing synthetic approaches to the complex multi-ring systems of polycyclic aromatic hydrocarbons. This work has been summarized by E. Clar in his two-volume work, "Polycyclic Hydrocarbons."⁶⁴ A number of the synthetic intermediates developed during this period are of use in preparing the more complex PAH metabolites. For example, the original synthesis of benzo(a)pyrene by Cook, Hewett and Hieger involved construction of the benzo-"A"-ring onto a preformed aromatic system, pyrene:¹¹

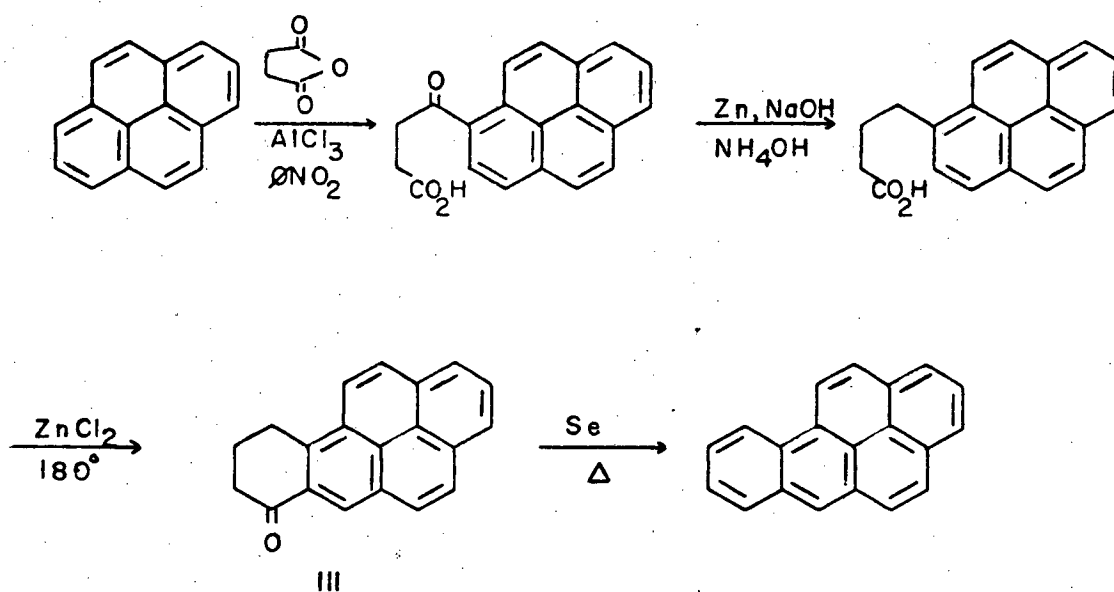

Ketone III is an obvious intermediate that could be used to introduce additional functionalities into the benzo-a ring. This approach was used by Sims in 1968 to prepare a number of 7,8,9,10-substituted benzo(a)pyrene derivatives.⁶⁵ Key intermediates first reported by Sims include 9,10-dihydrobenzo(a)pyrene (V) and 7,8-dihydrobenzo(a)pyrene (IX):

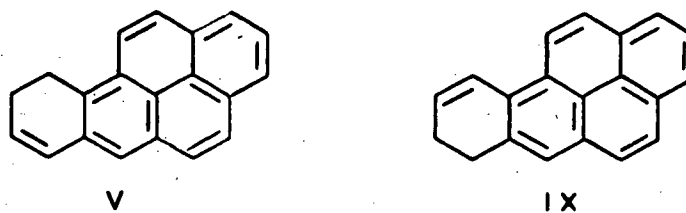

Both of these intermediates proved to be of subsequent value in preparing benzo-ring derivatives such as phenols, diols, and epoxides. A brief description of the various synthetic approaches to these derivatives follows; the diol epoxide synthesis involves work done in this laboratory.

Synthetic Dehydration Standards. As outlined in Chapter 2, our initial fluorescence studies on the covalent BaP-poly(G) complex required a number of benzo(a)pyrene derivatives for spectral comparison. The majority of these derivatives were known compounds, having been prepared in the 1940's as part of a large research effort directed towards the synthesis of complex, multi-ring systems (see reference 64 for a review of this work). However, none of these compounds were available commercially, and no physical data (aside from melting point and elemental analysis) were reported in the literature. Consequently, we undertook to repeat many of these syntheses, using modern synthetic methods where appropriate. Two key papers were of particular use in this work--one by Fieser and Novello,⁶⁶ and one by Cook, Hewett, and Hieger.¹¹ In addition, Sims reported in 1968 the preparation of a number of benzo-"A"-ring derivatives of benzo(a)pyrene.⁶⁵

I. Benzo-"A"-ring derivatives: 7,8,9,10-substituted benzo(a)-pyrenes. Figure 1 outlines the route used by Fieser and Novello to prepare 7-oxo-7,8,9,10-tetrahydrobenzo(a)pyrene (III). This material is a key intermediate for all 7,8,9,10-tetrahydrobenzo(a)pyrene derivatives; its method of preparation is essentially identical to that reported by Fieser. The Huang-Minlon modification of the Wolff-Kishner reduction⁶⁷ is used instead of the original Clemmensen reduction for preparing acid II; this results in higher yields (75% versus 60%) as well as being much more adaptable to large-scale (molar) preparative reactions. Several hundred grams of ketone III were eventually prepared for use in the syntheses and experiments reported here

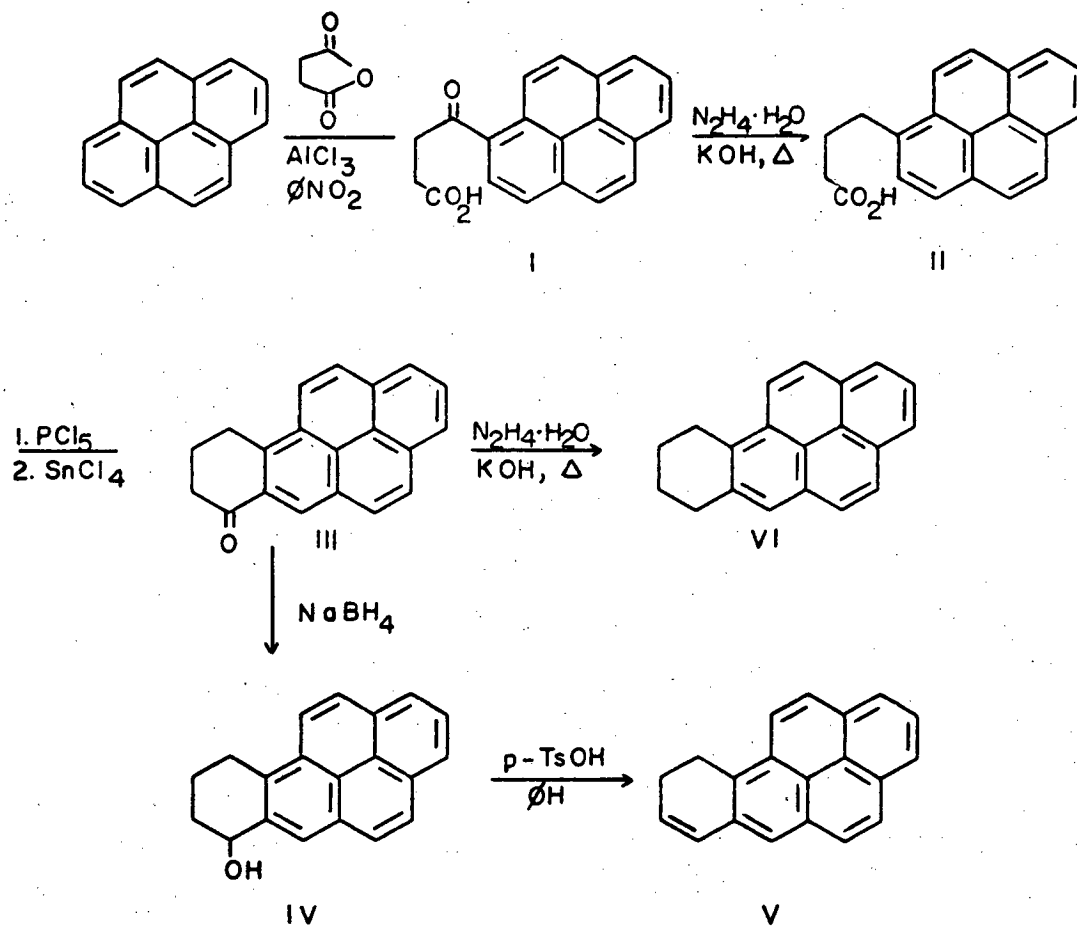

Figure 1

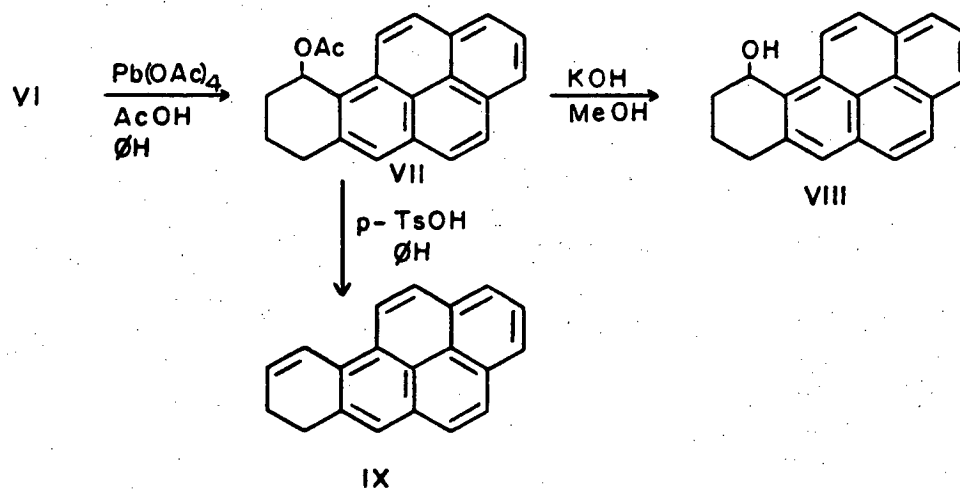

Figure 2

(Note 1). Ketone III was then transformed into a number of products, conveniently divided into hydrobenzo(a)pyrenes, monohydroxy-7,8,9,10-tetrahydrobenzo(a)pyrenes, and dihydroxy-7,8,9,10-tetrahydrobenzo(a)pyrenes. Figures 1 - 4 outline these various interconversions.

A second key intermediate was 9,10-dihydrobenzo(a)pyrene (V), formed by reduction of III with sodium borohydride and subsequent dehydration (p-toluenesulfonic acid/ ϕ H). Relatively mild dehydration conditions (temperature $< 80^{\circ}$) were found to be essential; the procedure of Sims⁶⁵ (AcOH/118 $^{\circ}$ /15 min.) was found to yield fully aromatized material (benzo(a)pyrene) as a side product (ca. 5%, analysis by HPLC). 7,8,9,10-Tetrahydrobenzo(a)pyrene (VI) was prepared by Wolff-Kishner reduction of ketone III, followed by chromatography on alumina.

Derivatization of the 9,10-positions of 7,8,9,10-tetrahydrobenzo(a)pyrene was accomplished via free radical acetoxylation as first reported by Kon and Roe.⁶⁸ The acetoxy derivative VII was isolated by repeated recrystallization of the crude product; conversion to 10-hydroxy-7,8,9,10-tetrahydrobenzo(a)pyrene was then accomplished via basic hydrolysis (KOH/MeOH) and subsequent recrystallization of the product. 7,8-dihydrobenzo(a)pyrene (IX) was obtained by acid-catalyzed dehydration (p-toluenesulfonic acid/ ϕ H) of compound VII, followed by column chromatography on activated alumina.^{65,69}

Note 1: Ketone III has recently become commercially available from Aldrich Chemical Company, Milwaukee, Wisconsin at \$30/5 gm (1978 listing).

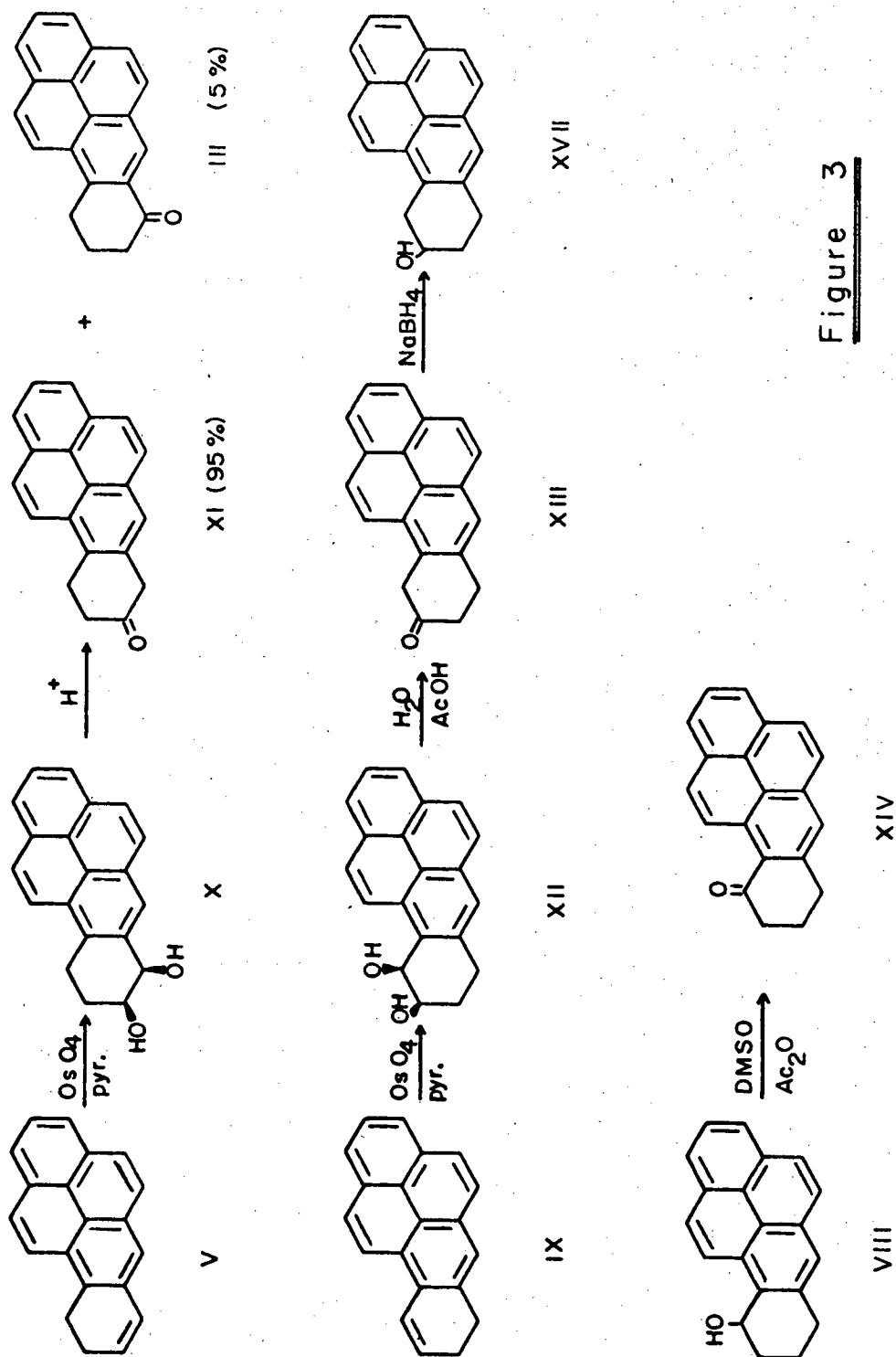

Figure 3

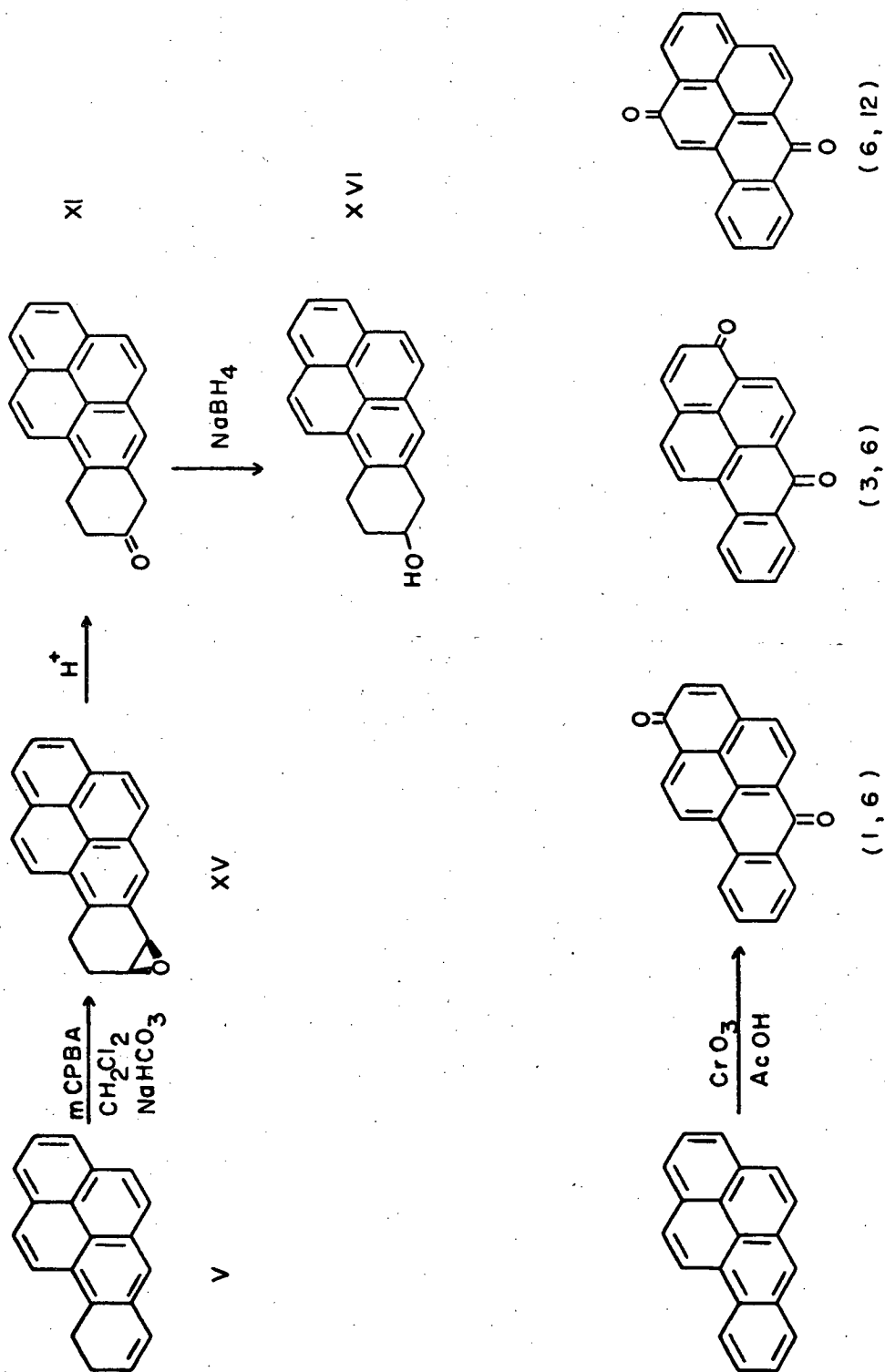
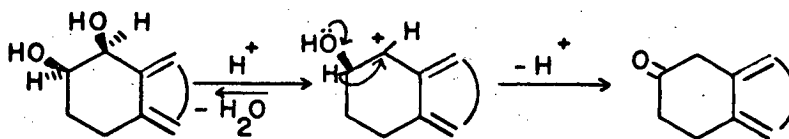

Figure 4

Conversion of 9,10-dihydrobenzo(a)pyrene (V) and 7,8-dihydrobenzo(a)pyrene (IX) to their corresponding cis-diols (X and XII) was accomplished by oxidation with osmium tetroxide (OsO_4).⁶⁵ Cleavage of the intermediate osmate ester complex by reduction with sodium bisulfite was found to be superior to literature procedures employing H_2S or trans-esterification (KOH -mannitol).⁴⁰ The bisulfite procedure results in a water-soluble osmium-pyridine complex, allowing straightforward isolation and purification of the chloroform-soluble cis-diol.

The three tetrahydrobenzo(a)pyrene ketones XI, XIII, and XIV were required for use as chromatographic standards in the dehydration studies outlined in Chapter 2. 10-Oxo-7,8,9,10-tetrahydrobenzo(a)pyrene (XIV) was readily obtained by oxidation of the 10-hydroxy compound VIII with $\text{DMSO-Ac}_2\text{O}$ reagent.⁷¹ 9-Oxo-7,8,9,10-tetrahydrobenzo(a)pyrene (XIII) was obtained by dehydration of cis-diol XII under acidic conditions. The exclusive formation of the 9-ketone in this reaction is presumably due to stabilization of the carbonium ion formed at the benzylic 10-position:



The 9 and 10-ketones (XIII and XIV) are separable by HPLC (see "Experimental"), and no detectable 10-keto material was found in the reaction product from acid dehydration of cis-diol XII. This was not the case for hydrolysis of the cis-7,8-diol X; a small amount ($\sim 5\%$) of 7-ketone III was formed along with 8-ketone XI. Since purification

of the 8-ketone (XI) by HPLC was impractical, an alternate route was used, involving acid hydrolysis of 7,8-epoxy-7,8,9,10-tetrahydrobenzo(a)pyrene:

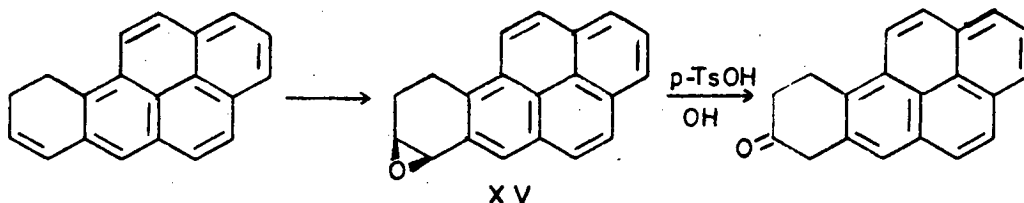

Epoxide XV was prepared by oxidation of V with *m*-chloroperbenzoic acid, using a two-phase solvent system ($\text{CH}_2\text{Cl}_2/10\% \text{NaHCO}_3$) to neutralize any *m*-chlorobenzoic acid formed in the reaction.⁷² Treatment of epoxide XV with *p*-toluenesulfonic acid and subsequent column chromatography (alumina) yielded the 8-ketone XI free of any contaminating 7-ketone III (as analyzed by HPLC).

8-Hydroxy and 9-hydroxy-7,8,9,10-tetrahydrobenzo(a)pyrenes XVI and XVII were prepared by sodium borohydride reduction of the corresponding ketones; the reaction products were isolated by HPLC and characterized by absorption, infra-red, and mass spectra. Insufficient material was isolated for elemental analysis or NMR spectroscopy.

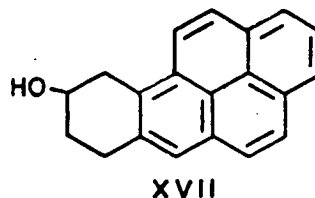
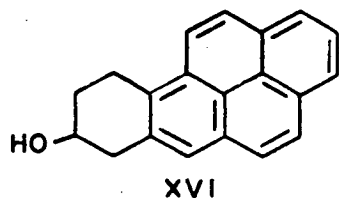

II. Other Benzo(a)pyrene Derivatives. Other benzo(a)pyrene derivatives used as fluorescence standards include the K-region cis-diol, 4,5-dihydroxy-4,5-dihydrobenzo(a)pyrene (XVIII), and the quinones

formed by oxidation of benzo(a)pyrene with chromic acid. This cis-diol was originally prepared by Crigee et al.⁷³ using osmium tetroxide. The diol thus obtained is extremely sensitive to oxidative degradation, requiring the use of an inert atmosphere for all operations. Harvey and Goh reported in 1974 a detailed procedure for isolating the diol, involving cleavage of the intermediate osmate ester with KOH-mannitol, acetylation to a diacetate, column chromatography, and removal of the acetate-protecting groups with methanolic ammonia.⁷⁴ We have found that cleavage of the osmate ester using aqueous bisulfite (as outlined above) is a superior method, although purification and handling of the diol is facilitated by conversion to the more stable diacetate. The reason for the extreme lability of the 4,5-diol is not fully understood; on exposure to air some material with UV-absorption properties of a quinone are formed, along with a red oil. Other workers have reported similar observations.^{73,74}

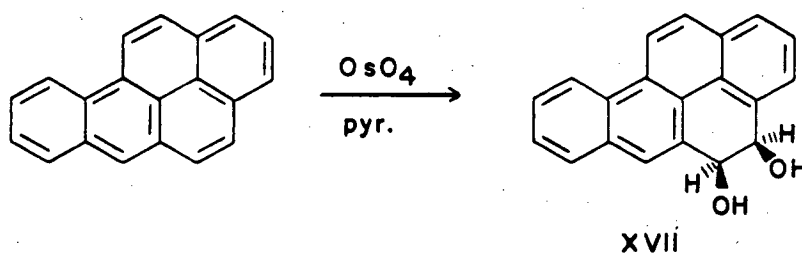

Oxidation of benzo(a)pyrene to a mixture of quinones (1,6 3,6 and 6,12; figure 4) by the action of chromic acid was first reported by Vollmann.⁷⁵ The individual quinones can be partially resolved by HPLC (Micropak C₁₈, H₂O-MeOH solvent). Sufficient material for use as absorption spectrum standards could be obtained by this procedure. Direct synthesis of each quinone has been reported,^{76,77} and analytical standards of each were obtained from the National Cancer Institute,

Bethesda, Maryland.

Arene Oxide Synthesis. It is convenient to divide arene oxides into two categories, described as K-region and non-K-region types. The K-region, or phenanthrene-5,6-type double bond, was thought at one time to be the primary structural feature of a polycyclic aromatic hydrocarbon responsible for biological activity.⁷⁸ Early (pre-1970) synthetic work was concentrated on the preparation of K-region derivatives for two reasons--the presumed biological relevance of such derivatives, and the relative ease with which the K-region double bond could be functionalized. Two principal reactions are of use in functionalizing this bond: ozonolysis,⁷⁹ producing a dialdehyde, and oxidation by OsO_4 ,⁷³ yielding an intermediate osmate ester which can be hydrolyzed to give a cis-dihydrodiol. Phenanthrene, for example, will yield either the dialdehyde I or the cis-diol II on treatment with O_3 or OsO_4 , respectively:

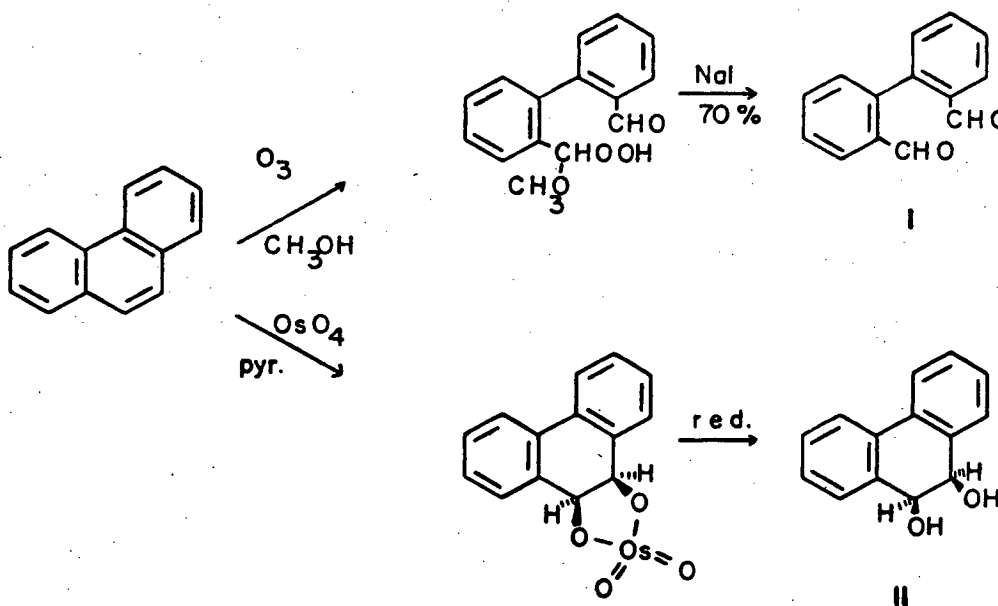

Both reactions depend on the fact that the mobile bond order is highest for the K-region-type double bond: in addition, the K-region

does not possess full aromatic character, and its excision from the molecule does not greatly alter the overall resonance energy for the molecule.⁸⁰ The K-region thus is similar in reactivity to an isolated double bond, and is susceptible to attack by electrophilic reagents.

The first arene oxide to be prepared was that of phenanthrene, via conversion of the dialdehyde I to the oxirane by treatment with hexamethyl phosphorous triamide:^{81, 82}

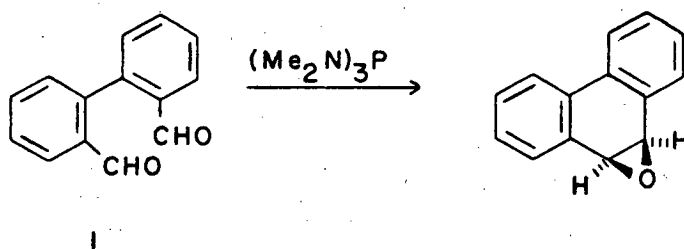

7-methylbenz(a)anthracene-5,6-oxide was prepared in a similar fashion. With more complex ring systems, however, ozonolysis has been found to generate a complex mixture of products, including quinones.⁸³ Oxidation with OsO₄, in contrast, usually results in only a single major product, and has consequently become the method of choice for functionalizing the K-region double bond of complex PAH's (Note 1).

Two methods are now available for converting a cis-diol into an oxirane. The first, reported in 1973 by Harvey and co-workers, involves conversion of the cis-diol to a trans-diol and subsequent oxirane

Note 1: Benzo(a)pyrene formally has two K-regions, the (4,5) and (11,12) bonds. Both HMO⁸⁴ and SCF⁴⁹ calculations indicate that the bond order of the 4,5-bond is higher than that of the 11,12-bond. Oxidation of BaP by OsO₄ yields both cis-diols in approximately a 20:1 ratio.⁸⁵

formation by treatment with the dimethylacetal of dimethylformamide (figure 5).^{74,86} The second method involves conversion of the cis-diol to a 2-alkoxy-1,3-dioxolane, subsequent conversion to a halohydrin ester, and then base-catalyzed nucleophilic displacement of the halogen by the hydroxyl oxygen (figure 6).⁸⁷ This second method has some advantages over the first, as the conversion from cis-diol to arene oxide can be carried out sequentially in the same reaction vessel without the need for isolation or purification of intermediates.⁸⁸ Both procedures have been used to prepare a number of K-region oxides of polycyclic aromatic hydrocarbons, including phenanthrene, pyrene, chrysene, 7,12-dimethylbenz(a)anthracene, and benzo(a)pyrene.

A direct oxidation of the aromatic hydrocarbon to a K-region oxide using hypochlorite plus a phase-transfer catalyst has recently appeared.⁸⁹ The application of this synthetic scheme seems to be restricted to molecules of high symmetry, due to the complex product mixtures generated from non-symmetrical, large PAH's. This technique appears to be the method of choice, however, for generating large (multigram) quantities of the K-region oxides of phenanthrene, pyrene, and chrysene.

Non-K-region Arene Oxides. Approaches to non-K-region arene oxides are of necessity less direct than those outlined above for the K-region oxides, and can involve complex ring-constructing schemes rather than the straightforward modification of one area of a pre-existing aromatic system. The complexity of a given scheme for an arene oxide synthesis can vary widely, depending on the types of intermediate ring systems that are required, as well as the stability and reactivity of the final product. For benzo(a)pyrene, for example,

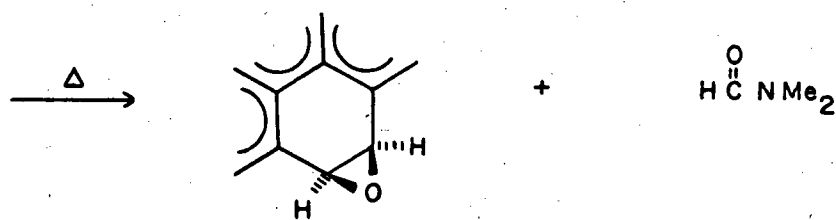
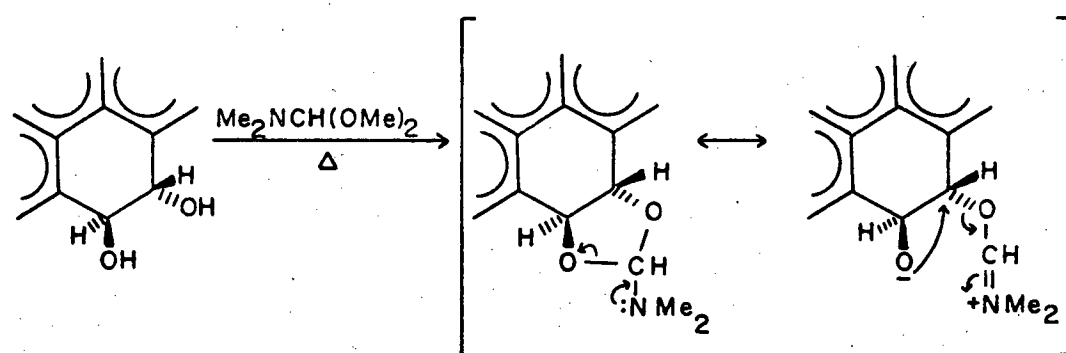
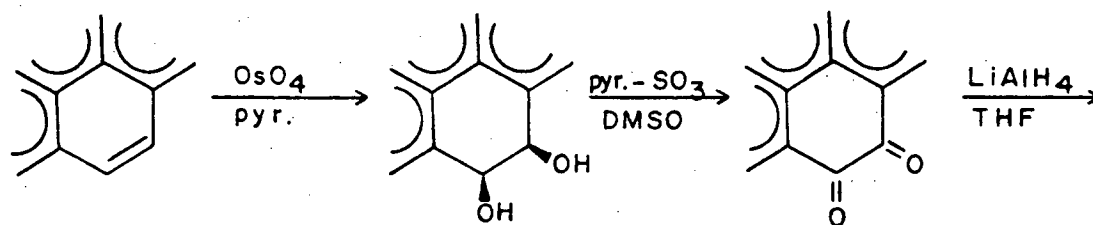

Figure 5

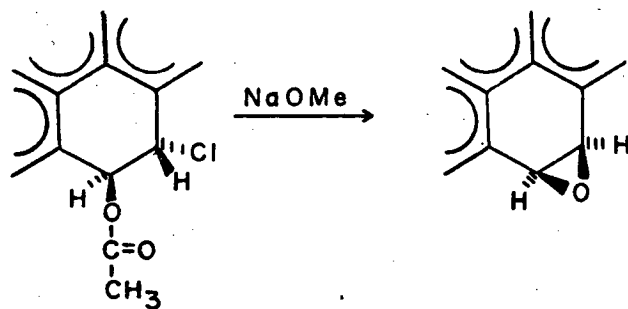
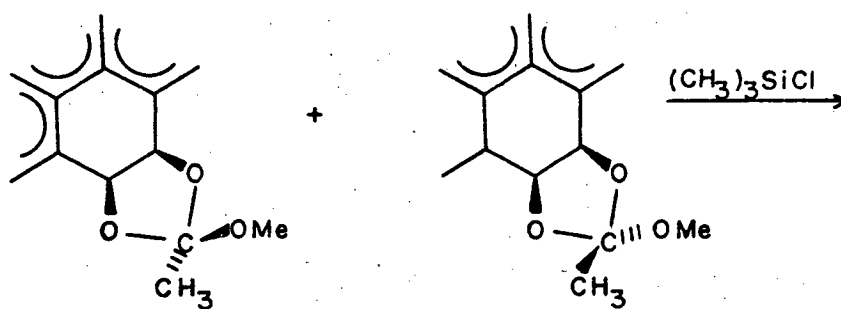
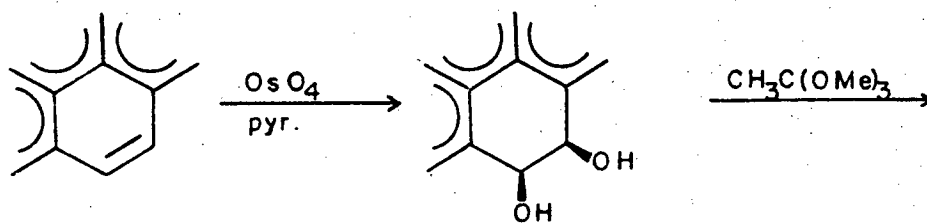
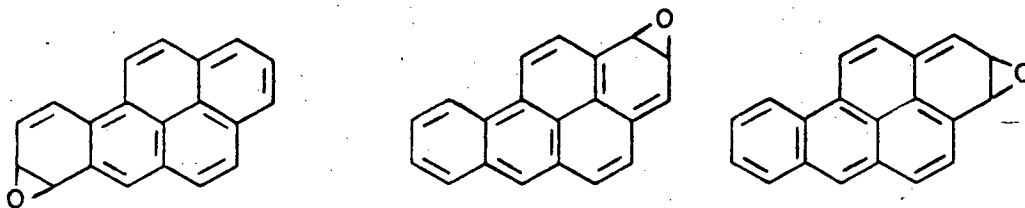
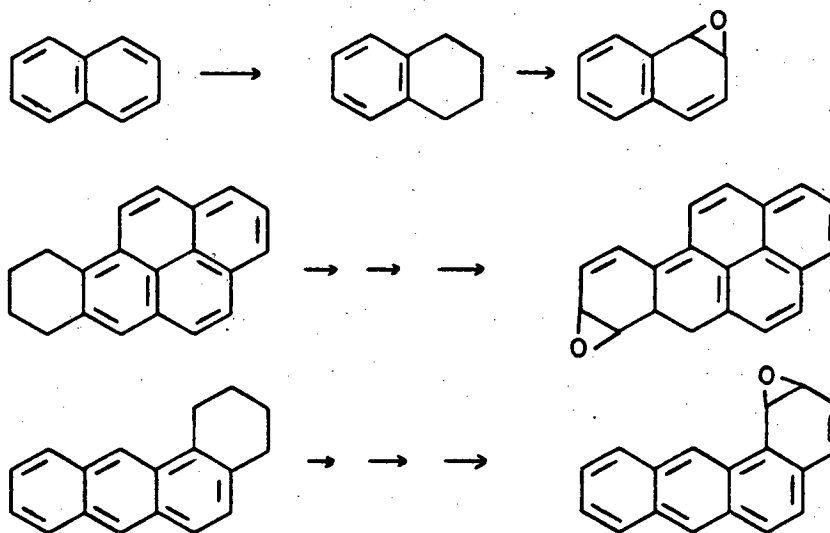

Figure 6

relatively facile routes to the 7,8 and 9,10 oxides have been elucidated, whereas the 1,2 and 2,3 oxides have so far defied synthesis.



The bulk of the synthetic work on non-K-region arene oxides has until now involved elaboration of a tetrahydro-benzo ring to generate a 1,2-epoxide with a 3,4 double bond in conjugation with the aromatic nucleus of the remainder of the molecule:



This allows one to proceed via construction of the tetrahydrobenzo-ring onto a preformed aromatic nucleus, or in favorable cases by selective reduction of one ring of the parent hydrocarbon:⁹⁰

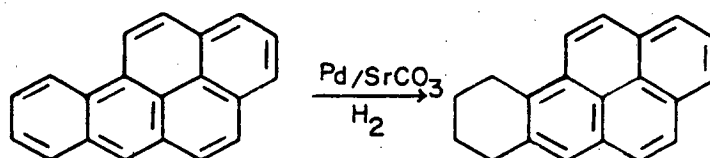
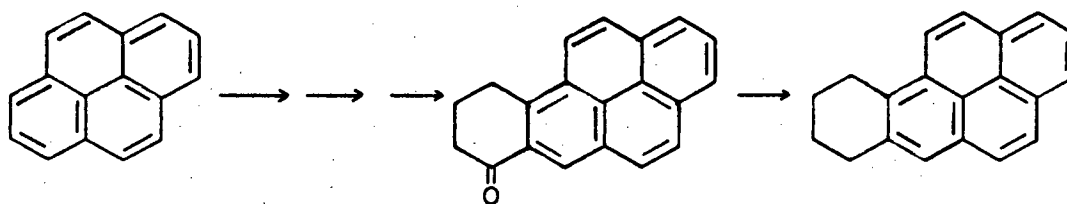

The first reported synthesis of a non-K-region arene oxide was that of naphthalene-1,2-oxide, published in 1968 by Vogel and Klärner.⁹¹ The overall logic of this synthesis formed the basis for later work by other groups. The synthesis is outlined in Figure 7a; the key step involves introduction of the 3,4-double bond into the tetrahydro ring system of epoxide C. This was accomplished by free radical bromination at the benzylic 4-position, followed by dehydrohalogenation with 1,5-diazabicyclo [3.2.0] non-5-ene at 0°. The utility of this synthetic sequence is hindered by the extreme lability of bromo-epoxide D, and subsequent attempts to generalize the sequence to other aromatic systems met with little success. In 1972 Waterfall and Sims attempted to use this scheme for the preparation of non-K-region oxides of benzo(a)-pyrene (Figure 7b).⁶⁹ Analysis of their data indicates that the attempted bromination of epoxide E gave a mixture of uncharacterized products, possibly polymeric in nature. Acid hydrolysis of the crude reaction mixture yielded material with chromatographic properties similar to that of a phenol, suggesting that the oxirane may have

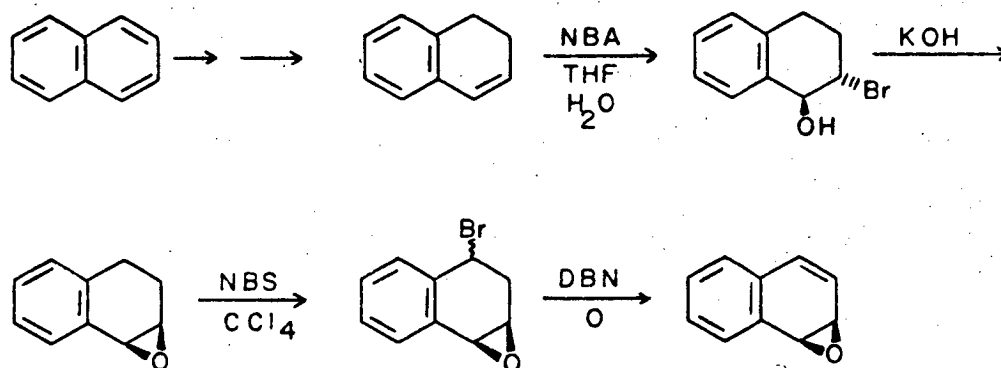

Figure 7 a

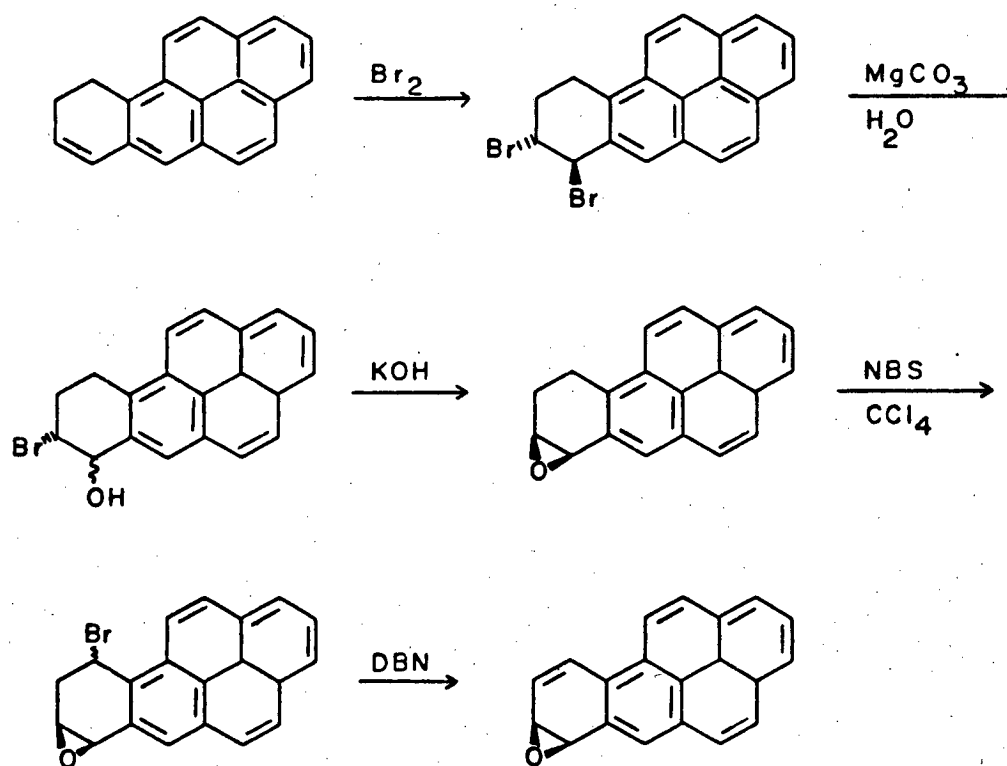
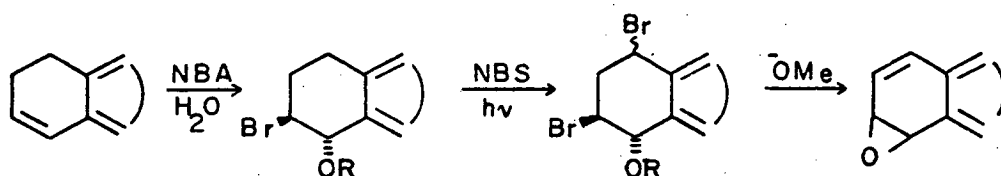

Figure 7 b

been present. Such a synthetic scheme was not capable of yielding analytically pure material, however. Jerina and coworkers subsequently modified this scheme by introducing both the epoxide and the double bond simultaneously.^{92,93} The epoxide is present as a bromohydrin precursor:



The Jerina synthesis (1973-1974) resulted in milligram quantities of pure arene oxides for several hydrocarbons, including the benzo(a)-pyrene-7,8 and 9,10-oxides.

Diol Epoxide Synthesis. As outlined in Chapter 2 fluorescence studies indicated that an active alkylating agent involving a 7,8,9,10-tetrahydro-substituted benzo(a)pyrene was responsible for covalent binding to nucleic acids in both microsomal and cell culture *in vitro* systems. Model compound studies suggested the presence of hydroxyls at position 7 and 8 of the tetrahydro-ring. The DNA/metabolite binding assay of Borgen *et al.*⁶¹ suggested that trans-7,8-dihydroxy-7,8-dihydrobenzo(a)pyrene possessed exceptional binding capabilities, and mutagenesis studies indicated high activity for this compound.⁶² All of this evidence suggested that the trans-7,8-dihydrodiol of benzo(a)-pyrene could undergo further metabolism to an active alkylating species, which when bound to nucleic acid exhibited a fluorescent chromophore similar to that of 7,8,9,10-tetrahydrobenzo(a)pyrene. The most likely structure for this alkylating species is that of a diol-epoxide, where

the 9,10-double bond of the 7,8-dihydrodiol has undergone oxidation to an epoxide:

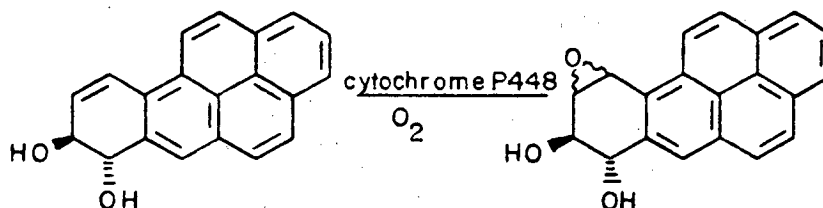

Work by Sims et al. indicated that metabolically formed [G-³H] 7,8-dihydrodiol could be oxidized with *m*-chloroperbenzoic acid to a material that was capable of binding to DNA in vitro; the resulting material had chromatographic properties similar to that of DNA-bound microsomal-activated benzo(a)pyrene.⁶³ The stereochemistry of the epoxide ring can be either cis or trans with respect to the 7-hydroxyl; presumably either isomer could be formed in vivo. The synthesis of this material, then, became our goal. The most obvious approach to this structure is to mimic the biosynthetic route (as Sims did on a micro-scale): synthesize the dihydrodiol and convert it to the diol-epoxide. It was anticipated that large quantities (multigram) of material would be required, so the development of an efficient synthesis for the 7, 8-dihydrodiol was our immediate goal.

An obvious approach to this structure is by introduction of the diol functionality into a tetrahydrobenzo(a)pyrene, followed by generation of the 9,10-double bond. This approach is similar to the logic used by Vogel and Klärner in their 1968 synthesis of naphthalene-1,2-oxide:⁹¹ the epoxide ring was introduced first, and the 3,4-double bond introduced by benzylic bromination followed by dehydrohalogenation (see Figure 7a). The overall synthetic scheme, then, would

involve conversion of 9,10-dihydrobenzo(a)pyrene (V) to trans-7,8-dihydroxy-7,8,9,10-tetrahydrobenzo(a)pyrene, followed by introduction of the 9,10-double bond via a benzylic halogenation/dehydrohalogenation sequence.

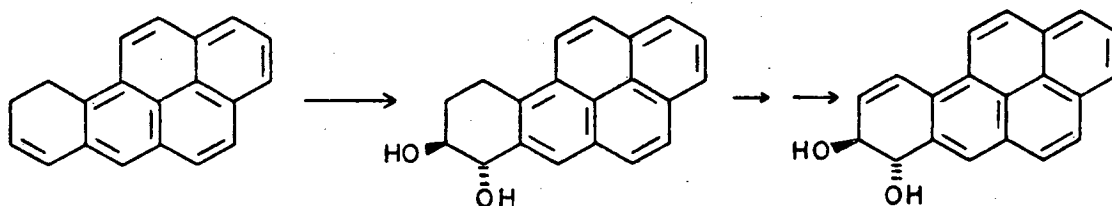

Since we had ready access to 7,8-epoxy-7,8,9,10-tetrahydrobenzo(a)pyrene (XV), an attempt was made to stereospecifically open the epoxide ring to a trans-diol. Literature references indicated that the only conditions capable of highly stereospecific ring opening involved the use of a strongly basic environment, such as KOH in 85% DMSO-water.⁹⁴ When the epoxide was treated in this fashion, a quantitative yield of benzo(a)pyrene was obtained (confirmed by HPLC retention time, UV and mass spectra). Presumably a diol is formed initially, and then undergoes multiple dehydration to the completely aromatized hydrocarbon:

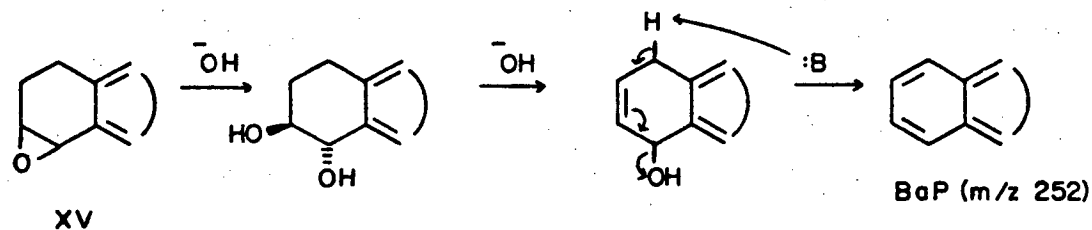

Identical results were obtained at 0°, 25°, and 100°. Hydrolysis of the epoxide under acidic conditions (1:1 THF-water, trace of HCl) gave three peaks when analyzed by HPLC. The minor component (ca. 10% of total) was identified as 8-oxo-7,8,9,10-tetrahydrobenzo(a)pyrene (HPLC

retention time, mass spectra identical with synthetic standard). The remaining two peaks (A and B, present in a ratio of 45:55) had identical UV, IR, and mass spectra (m/z 288): peak A co-chromatographed with authentic cis-7,8-dihydroxy-7,8,9,10-tetrahydrobenzo(a)pyrene (synthesized by OsO_4 oxidation of 7,8-dihydrobenzo(a)pyrene). Peak B was therefore assigned as the trans-diol, confirmed by its 1H -NMR spectrum ($J_{7,8} = 10$ Hz; cis-diol has $J_{7,8} = 5.5$ Hz). These results indicated that hydrolysis of the tetrahydro epoxide XV was not suitable for preparing the trans-diol.

A review of literature methods for converting olefins to trans-diols suggested the use of an aryl or acyl hypoiodite--i.e., the Prevost reaction.⁹⁵ Our initial concerns that the hypoiodite complex might iodinate the highly active pyrene nucleus were alleviated by a conversation with Dr. D. J. McCaustland of Midwest Research Institute (Kansas City, Missouri), in which he informed us that they had successfully used the Prevost reaction to prepare trans-diols from a number of aromatic-substituted ethenes. When the reaction was tried, conversion of 9,10-dihydrobenzo(a)pyrene to a 7,8-dibenzoate was readily accomplished in 65% yield. Trans stereochemistry is generated by the mechanism of the reaction:

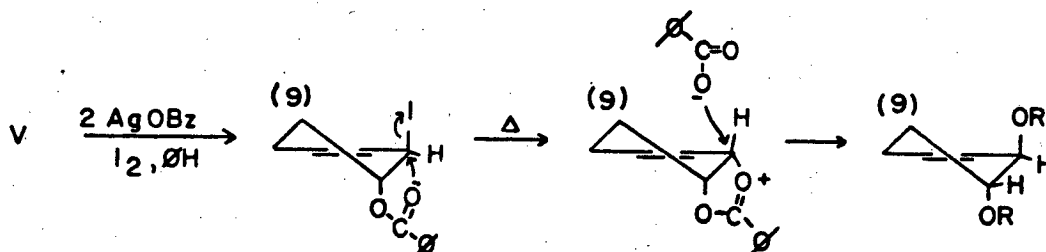

The trans-stereochemistry was confirmed by removal of the benzoates

(^-OMe) and $^1\text{H-NMR}$ of the free diol--- the large $J_{7,8}$ (10 Hz) is indicative of trans-stereochemistry. The free diol also cochromatographed with peak B (above) obtained from acid hydrolysis of the tetrahydro epoxide (XV).

The bromination-dehydrobromination sequence to introduce the 9,10-double bond into the system appeared at first to be relatively straightforward. Such a sequence had in fact been used by Jerina et al. to synthesize the cis-dihydroxy isomer:

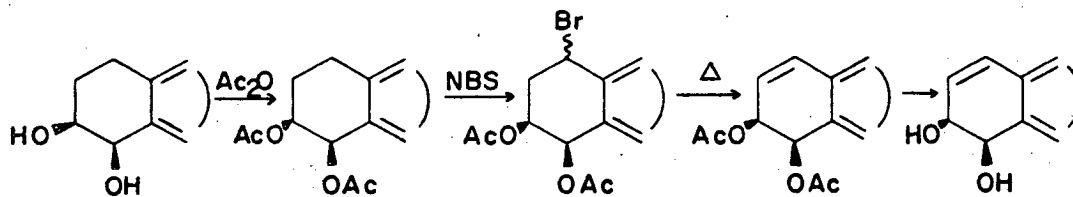

Our first attempt at brominating the dibenzoate (NBS, CCl_4 , $h\nu$) resulted in polymeric material, along with a small amount of material containing two bromines (mass spectra) and what appeared to be a fully aromatized system (UV absorption similar to that of benzo(a)pyrene). The problem was eventually traced to a small ($\approx 4\%$) amount of iodo-benzoate in the dibenzoate starting material. When analytically pure dibenzoate was used in the reaction, the 10-bromo derivative (stereochemistry unknown) was obtained in high yield ($\approx 75\%$). The reaction is nevertheless technically difficult, requiring the use of pure dibenzoate and rigorously defined experimental conditions (see "Experimental"). Thermal elimination of HBr (refluxing in xylene for approximately ten minutes) and removal of the benzoyl groups was accomplished without difficulty. This resulted in analytically pure (+)trans-7,8-dihydroxy-7,8-dihydrobenzo(a)pyrene (XXII, figure 8).

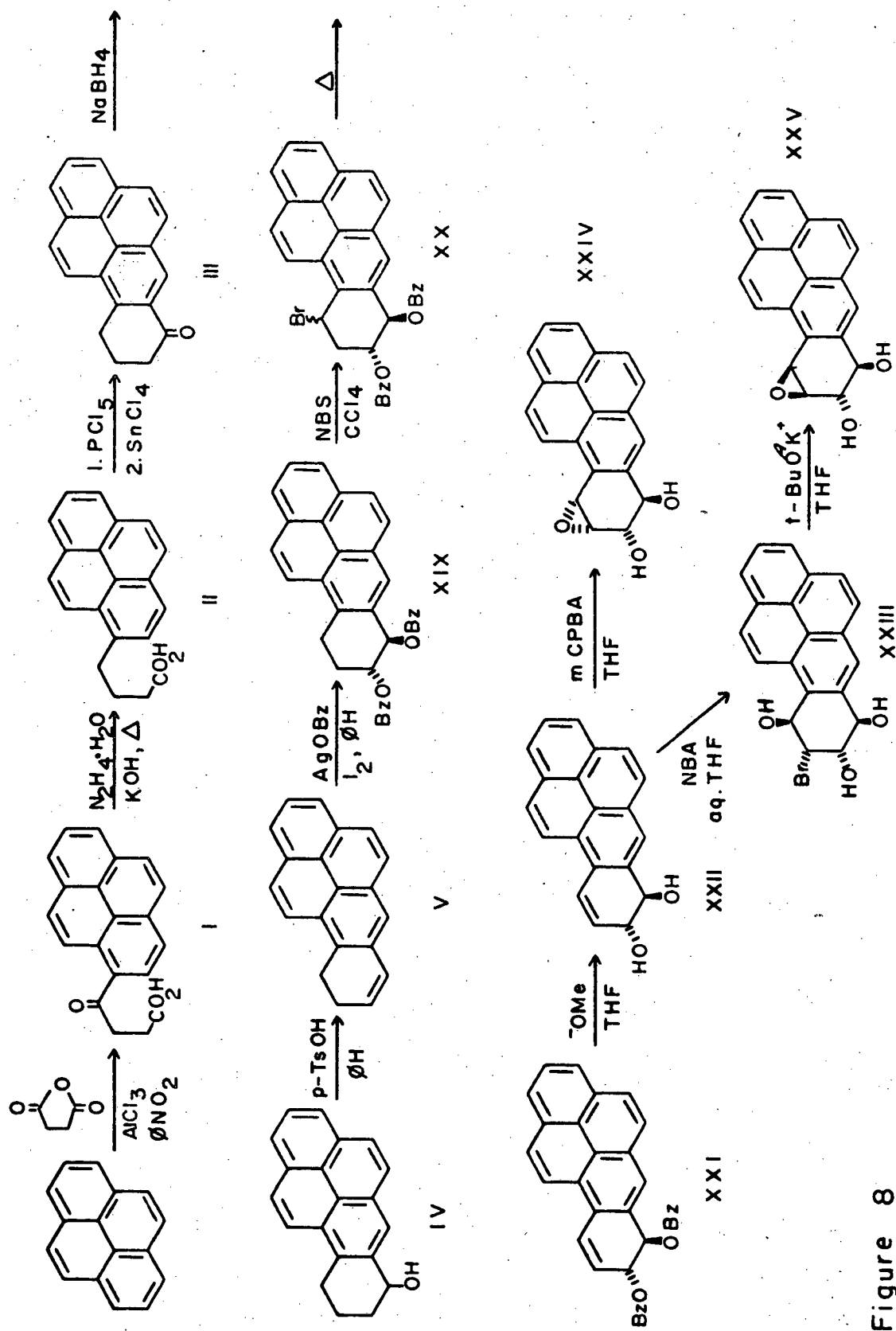
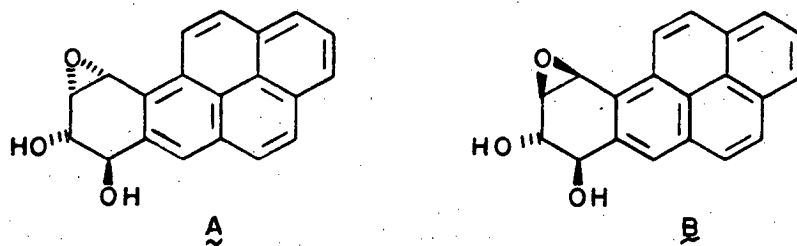
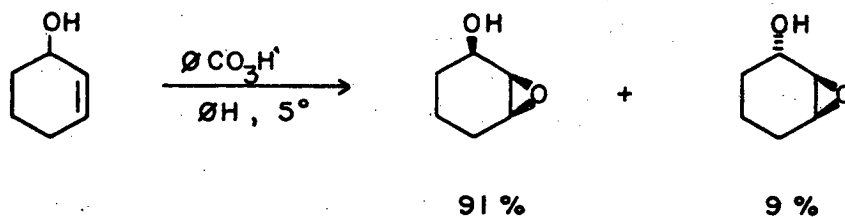

Figure 8

Epoxidation of this material would be expected to generate the two possible isomers (A and B), with the epoxide cis or trans with respect to the 7-hydroxyl. A preference for the cis isomer was predicted to occur with peracid oxidation, by analogy with known literature reactions. For example, epoxidation of 2-hydroxy-cyclo-



hexene by perbenzoic acid generates a preponderance of the isomer with the epoxide on the same face of the ring as the hydroxyl:⁹⁶



This stereospecificity is apparently the result of hydrogen-bonding between the peracid and hydroxyl group in the transition state for the reaction:⁹⁷

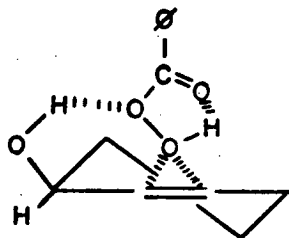

Epoxidation of the trans-7,8-diol with m-chloroperbenzoic acid (mCPBA, a more efficient epoxidation reagent than perbenzoic acid) in CH_2Cl_2 resulted in a number of undefined products. In benzene, the reaction proceeded slowly (reaction was monitored by the change in absorption spectrum from the 9,10-dihydro benzo(a)pyrene chromophore to that of a 7,8,9,10-tetrahydrobenzo(a)pyrene), and mass spectrometry indicated the presence of a species with the molecular weight of a diol epoxide. The optimum solvent for this reaction was found to be tetrahydrofuran, where reaction is essentially complete in six hours. The reason for this solvent dependence is unknown, although it has been noted by two other groups.^{98,99} Jerina identified one of the products generated in CH_2Cl_2 as a chlorobenzoate ester of trihydroxy-7,8,9,10-tetrahydrobenzo(a)pyrene, presumably formed by reaction of the initially formed diol epoxide with m-chlorobenzoic acid.⁹⁸ It is possible that trace amounts of acid present in some solvents lead to immediate decomposition of the highly reactive diol-epoxide.

The stereochemistry of the material formed in this reaction was unknown, but the product appeared to be a single stereoisomer (see Table 1). In an aqueous cosolvent (THF-water, 20:80) two products were rapidly formed (reaction complete in under twenty minutes), and identified as tetrahydroxy-7,8,9,10-tetrahydrobenzo(a)pyrenes. A single stereoisomer of the diol epoxide would be expected to generate two tetraols upon hydrolysis, whereas four tetraols would be generated if both stereoisomers were present:

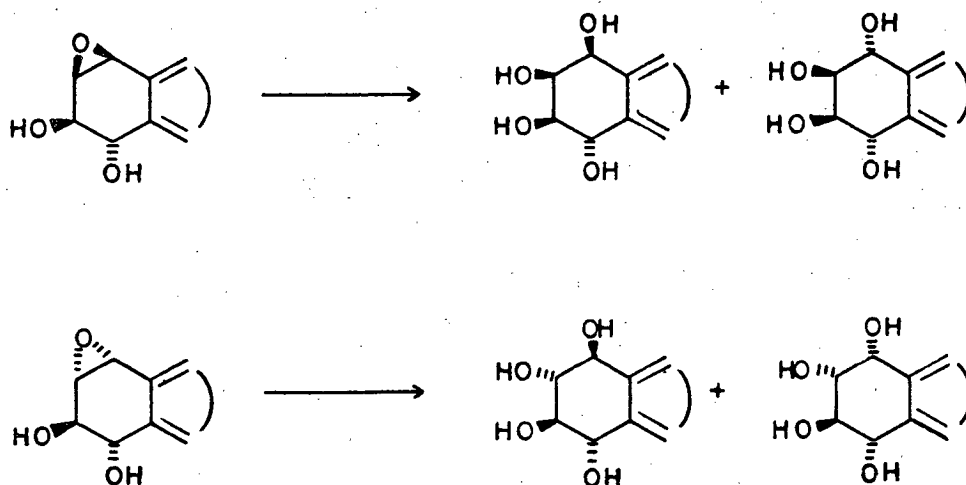

The orienting effect of the 8-hydroxyl on the peracid would be expected to generate the epoxide on the same face of the ring, and opposite to the 7-hydroxyl:

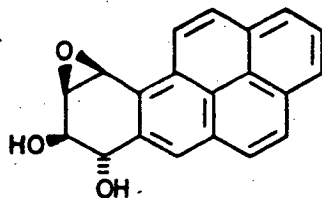

At the time this work was being completed, a virtually identical synthesis of this diol epoxide appeared, but without any conclusions as to the stereochemistry of the product.⁹⁹ ¹H-NMR evidence was suggestive that the 8-hydroxyl and epoxide were cis to each other, but the absence of any reference compounds made such an assignment rather tenuous. ($J_{7,8} = 8.6$ Hz is consistent with pseudo-equatorial hydroxyls,¹⁰⁰ and the small value of $J_{9,10}$ [<1 Hz] suggests that the 9,10 epoxide and 8-hydroxyl are cis to each other).

The solution to this problem was first advanced by Jerina and coworkers, who succeeded in synthesizing the two corresponding diol epoxide isomers of naphthalene (C and D):^{98,101}



Direct epoxidation of 1,2-dihydroxy-1,2-dihydronaphthalene generates compound D, as expected. The other isomer, C, was synthesized by the same reaction sequence Jerina had used in the synthesis of the non-K-region arene oxides--via a bromohydrin.⁹³ Reaction of the diol with N-bromoacetamide (NBA) in aqueous-THF gave a halohydrin ester with an NMR spectrum consistent with a cis-2-hydroxyl and 3-bromine ($J_{2,3} \approx 2.49$ Hz):

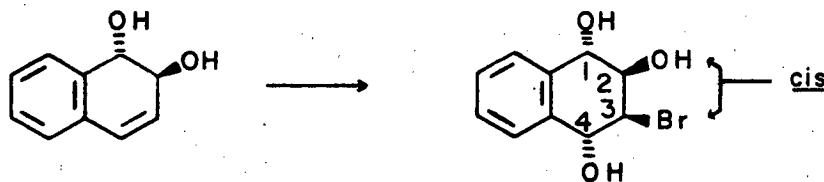

Conversion of this bromohydrin to diol epoxide C was achieved with base. Once both isomers were available for direct comparison, the assignments of relative stereochemistry based on ¹H-NMR data was relatively straightforward (see Table 1). When the 7,8-dihydrodiol of benzo(a)pyrene was treated with NBA, a similar result was obtained--a bromohydrin with protons at positions 7 and 8 ($J_{8,9} = 3$ Hz) was isolated. Treatment with base gave material with UV, IR, and mass spectra similar to that

of the diol epoxide formed via peracid oxidation, but with a different $^1\text{H-NMR}$ spectrum (Table 1). The 7-hydroxyl resonance is shifted up-field by approximately 160 Hz (at 220 MHz), indicative of intramolecular hydrogen-binding between the 7-hydroxyl and 9,10-epoxide oxygen.¹⁰² Final confirmation of the assignments was provided by analyzing the products formed on hydrolysis of diol epoxide B: two tetrahydroxy-7,8,9,10-tetrahydrobenzo(a)pyrenes were formed, with completely different retention times from the tetraols formed by hydrolysis of diol-epoxide A. $^1\text{H-NMR}$ analysis of these two sets of tetraols provided good evidence for the assigned conformations;¹⁰³ in addition, a later analysis of the relative stereochemistry of the ring hydroxyls (detected by acetonide formation of cis-dihydroxy stereoisomers) of all four tetraols was fully consistent with these assignments.¹⁰⁴

Although there was ample literature precedence for the high degree of stereoselectivity observed in the peracid oxidation of the diol to diol epoxide "A," the specificity observed in bromohydrin formation was somewhat unexpected. Although steric arguments can be invoked to account for the approach of NBA cis to the pseudo-equatorial 8-hydroxyl, ($^1\text{H-NMR}$ indicates the hydroxyls in the diol are pseudo-equatorial), the fact that no detectable trans isomer is observed is surprising:

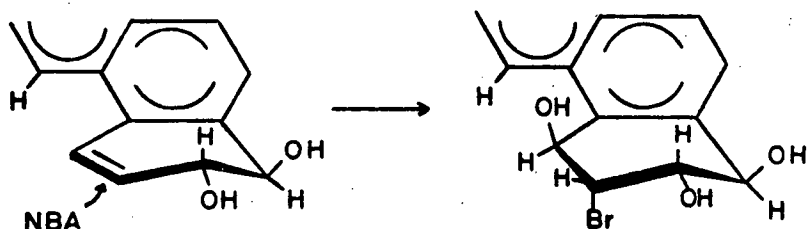

Conversion to the 9,10-epoxide is facilitated by the trans-1,2-diaxial conformation of the 10-hydroxyl and 9-bromine; formation of the 8,9

epoxide is not possible due to the cis conformation of the 9-bromine and 8-hydroxyl (Figure 8).

Table 1

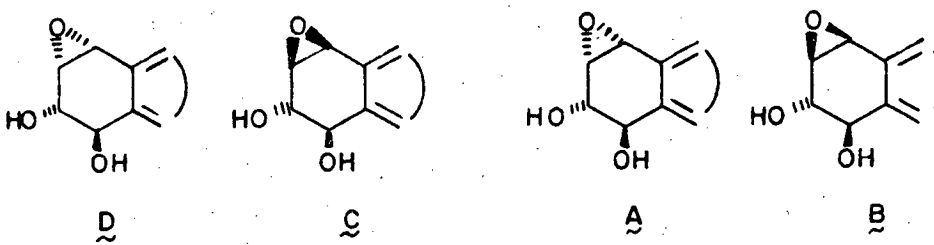

		Naphthalene		Benzo(a)pyrene		
		<u>D</u>	<u>C</u>	<u>A</u>	<u>B</u>	
ppm	H-1	4.31	4.38	(H-7)	4.86	4.96
	H-2	3.66	4.15	(H-8)	4.04	3.99
	H-3	3.60	3.69	(H-9)	3.95	3.88
	H-4	3.99	3.98	(H-10)	5.18	4.98
	C ₁ -OH	5.55	4.14	(C ₇ -OH)	6.01	5.24
	C ₂ -OH	5.47	5.47	(C ₈ -OH)	5.88	5.86
Hz	J _{1,2}	3.0	9.0	(J _{7,8})	8.6	5.8
	J _{2,3}	2.5	1.0	(J _{8,9})	1.0	1.5
	J _{3,4}	4.0	4.5	(J _{9,10})	4.5	4.1

[¹H-NMR spectra recorded at 220 MHz in FT mode].

The two isomeric diol epoxides A and B are abbreviated as "anti" and "syn," referring to the orientation of the 9,10 epoxide with respect to the 7-hydroxyl.

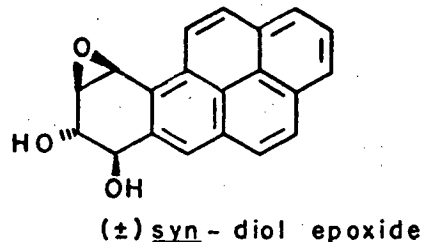
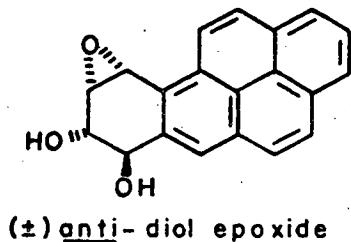

³H-Diol Epoxide Synthesis (Note 1). The extremely low level of binding of benzo(a)pyrene to DNA in vivo (ca. 1 in 10^4 - 10^5 base pairs) meant that the isolated adducts we would be working with would be present in microgram or nanogram quantities. These would presumably have to be detected against a large background of unmodified nucleic acid residues, making isolation a difficult analytical problem. The ability to quantify the levels of covalent binding to various target nucleophiles was also anticipated to be a problem. Consequently, we decided to prepare the diol epoxide "A" (r-7,t-8-dihydroxy-t-9,10-epoxy-7,8,9,10-tetrahydrobenzo(a)pyrene) in a radioactively labelled form (as described in Chapters 4-6, diol epoxide A is the predominant stereoisomer formed in vivo). Two principal requirements--expense and the need for high specific activity--dictated the use of ³H rather than ¹⁴C.

³H can be introduced into a structure by two basic procedures--catalytic exchange with ³H₂ gas, or by exchange in ³H₂O (usually at extremes of pH).¹⁰⁵ The high reactivity of the diol epoxide itself ruled out any direct exchange procedure; a synthetic precursor would have to be labelled and then converted to the diol epoxide. Since

Note 1: A similar synthesis of ³H - (+) anti-diol epoxide is described in reference 106.

the material would be used in biological, aqueous systems, it was decided that incorporation of the label into readily exchangeable positions of the molecule could lead to problems involving loss or randomization of the label. Additionally, the facilities available to us (Safety Services, Lawrence Berkeley Laboratory) allowed the use of carrier-free tritium gas at pressures up to 730 mm, permitting high specific activities to be realized.

The aromatic system of the tetrahydrobenzo(a)pyrene moiety is a logical choice for introduction of label into non-exchangeable (over the normal range of pH encountered in biological systems) sites. High specific activities ($> 1 \text{ Ci/mmol}$) can only be achieved with $^3\text{H}_2\text{O}$ under vigorous conditions (eg. $100\text{-}200^\circ/24 \text{ hr.}$); since we envisioned introduction of the label within a reasonable number of steps from the final product, such extreme conditions were ruled out. Suitable reaction sequences using tritium gas include hydrogenation/dehydrogenation (resulting in approximately 50% of the hydrogens at a given position being labeled) or halogenation/hydrogenolysis. The former method is difficult to carry out at low ($< 1 \text{ atm}$) pressure, so the halogenation/hydrogenolysis reaction sequence was employed.

The overall plan was to brominate the aromatic nucleus, then dehalogenate with tritium gas over a metal catalyst. The sensitivity of the 9,10-double bond to these conditions forced us to work with the tetrahydrobenzo(a)pyrene system, with the trans-dibenzoate already in place:

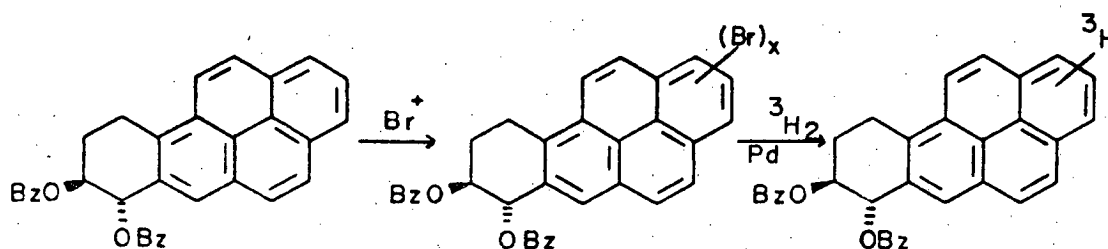

Bromination of the aromatic system was straightforward; virtually any source of Br^+ will efficiently label the system. Thus, treatment of dibenzoate XIX with phenyl trimethylammonium tribromide in acetic acid-THF resulted in a quantitative yield of monobromo-trans-7,8-dibenzoyl-7,8,9,10-tetrahydrobenzo(a)pyrene (M^+ at m/z 574,576; the ion at m/z 330, 332 and subsequent loss of $\text{Br}\cdot$ to generate m/z 251 showed that the bromine was on the tetrahydrobenzo(a)pyrene moiety rather than on the benzoate groups). The exact position of the halogen on the ring could not be determined, but the $^1\text{H-NMR}$ spectrum showed one less hydrogen in the aromatic region (7.32-8.50 δ). Analogous literature reactions indicate that the 6-position may be the site of substitution in such cases.⁹³ Model reaction studies with unlabelled H_2 showed that this monobromide could be efficiently (90% yield) reduced to the dibenzoate at low pressure (< 1.5 atm) over a palladium metal catalyst.

Accordingly, 30 mg of the bromo-dibenzoate in the presence of 10 mg palladium was treated with 52 Ci of carrier-free $^3\text{H}_2$ at 730 mm pressure for 3.75 hours. After work-up (initial activity 30 Ci/mmol) this material was diluted with unlabelled carrier dibenzoate to a final activity of ca. 2.38 Ci/mmol (the material still contained adsorbed $^3\text{H}_2$ gas). This material was then carried through the synthesis of trans-7,8-dihydroxy-7,8-dihydrodiol (XXII) on a micro-scale. The final

yield of diol was 100 mg, at a specific activity of $1.30 \pm .05$ Ci/mmol. The bulk of this material was converted to diol epoxide "A" (XXIV), and stored in THF at -70° . All intermediates cochromatographed with authentic synthetic standards; when the ^3H - diol epoxide was hydrolyzed, ca. 97% of the ^3H -counts eluted with the two expected tetrahydroxy-tetrahydrobenzo(a)pyrene products. The ^3H -diol epoxide stock solution was routinely monitored for decomposition (high specific activity materials are extremely sensitive to oxygen, water, and light; decomposition occurs primarily via free-radical reactions induced by intense β^- radiation) by hydrolysis and HPLC of the products. Aliquots from the run were analyzed for radioactivity by scintillation counting, and the total recovery was calculated. Decomposition was indicated by the amount of radioactivity that did not co-elute with the expected tetrahydroxy-tetrahydrobenzo(a)pyrene hydrolysis products. Over a period of eight months, decomposition was less than 0.5% per month.

^3H -7,8-diol +
unlabelled 7,8-diol (XXII)

Figure 9

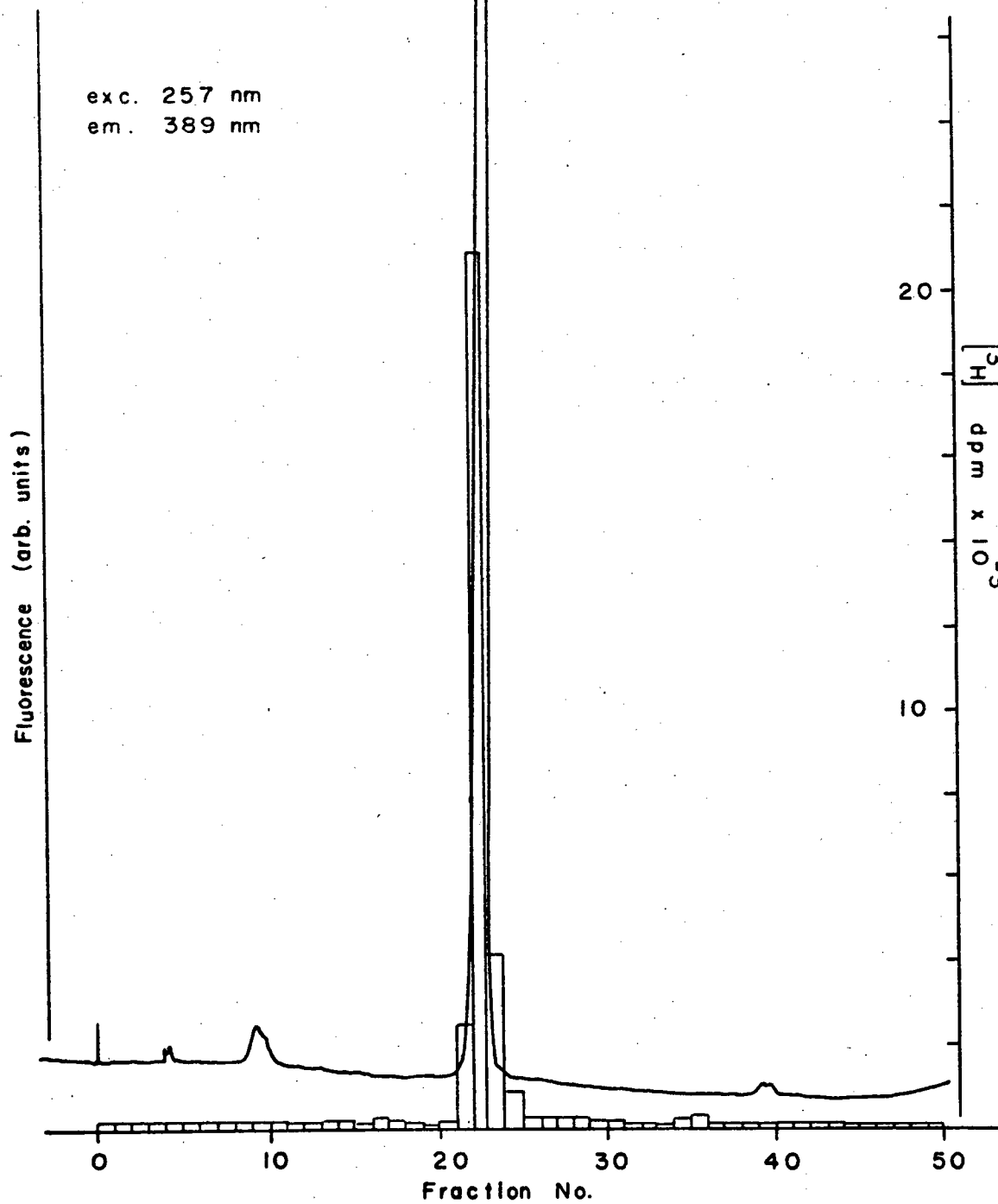

Experimental

Analytical Methods. All reactions were performed under a dry nitrogen atmosphere unless otherwise noted. Most of the reaction products reported here are sensitive to light and air, so appropriate precautions were taken. Melting points (uncorrected) were determined on a Buchi capillary melting point apparatus (Rinco Instrument Co., Greenville, Illinois). ^1H NMR spectra were recorded at 220 MHz with a Varian HR-220, equipped for Fourier Transform (FT) operation. Data was collected on a NIC-80 computer (Nicolet Instruments, Madison, Wisconsin). Alternatively, some spectra were recorded at 270 MHz on a non-commercial instrument, interfaced with a NIC-1180 computer. Absorption spectra were recorded on either a Varian/Cary Model 118 or Model 14 spectrophotometer (Cary/Varian, Palo Alto, California). Infrared spectra were recorded (as KBr pellets) on a Perkin-Elmer model 257 spectrophotometer (Perkin-Elmer, Norwalk, Connecticut). Low resolution mass spectra were determined at 70 eV on a duPont model 21-492-1 mass spectrometer, equipped with a 21-094B data system. Electron-impact high resolution mass spectra were determined by direct probe with a modified Kratos/AEI MS-902 mass spectrometer operated on-line at $m/\Delta m$ 10,000 with a Xerox Sigma 7/LOGOS II computer system (see Chapter 4 for a discussion of the LOGOS-II HRMS system). Elemental analyses were performed by the Analytical Laboratory, Department of Chemistry, University of California, Berkeley.

Safety Procedures. As is evident from discussions in Chapter 2 and 4-6, many of the compounds described here represent extreme safety hazards. The trans-7,8-diol (XXII), in particular, is a potent mutagen and carcinogen, with a relatively stable (i.e., not easily hydrolyzed)

or oxidized at neutral pH) structure. The anti-diol epoxide (XXIV) is one of the most potent mutagen/carcinogens known, as well as being highly cytotoxic. Other synthetic intermediates are not active as such, but can undergo enzymatic activation if inhaled or absorbed through the skin. Accordingly, all synthetic operations were carried out in a functioning hood, with appropriate protection (gloves, lab coat, and respirator filter if appropriate) for the operator. Particularly hazardous operations were conducted in a negative pressure glove box (Safety Services, Lawrence Berkeley Laboratory) equipped with micron air filters. Weighing out of dry powders of hazardous materials was done in such a glove box. Open laboratory hoods can be conveniently screened for contamination with an ultra-violet (350 nm) hand lamp, since virtually all benzo(a)pyrene derivatives have an intense blue or green fluorescence. Glassware was decontaminated with either chromic acid or nitric acid. Contaminated waste was disposed of by Environmental Health and Safety, Lawrence Berkeley Laboratory.

Chromatography. Thin layer chromatography (TLC) was carried out on Silica Gel G plates (either Eastman no. 6061 or prepared in the laboratory), using benzene or benzene-ethanol (19: 1 v/v) as the developing solvent. Most of the products described here fluoresce (em. > 390 nm) when excited at 350 nm, allowing visualization without the need for indicator dyes. Column chromatography was carried out on the appropriate activity grade of Woelm Neutral Alumina (Waters Associates, Milford, Massachusetts) or silica gel ("Biosil," BioRad, Richmond, California). All solvents were either "Nanograde" (Mallinckrodt, St. Louis, Missouri) or redistilled before use.

High pressure liquid chromatography (HPLC) was an important analytical tool in the work described here, allowing chromatographic separation and quantitative analyses to be carried out that are not possible by other techniques. Instruments used included a Varian model 8500 liquid chromatograph (Varian, Palo Alto, California) and a Waters model 6000 system (Waters Associates, Milford, Massachusetts). Reverse phase (octadecylsilane) columns were used extensively (0.2 x 25 cm, or 4.1 mm x 30 cm), with water-methanol as eluant. Alternatively, 5 μ silica gel (4.1 mm x 30 cm) was used for some analyses, with hexane-dichloromethane as eluant. A standard flow rate of 1 mL/min. was used, and the column effluent monitored for absorbance at selected wavelengths.

Synthetic Procedures. (Spectra are reported as: NMR, chemical shift (δ) relative to TMS; MS, m/z (relative intensity); UV, absorption wavelength (\log_{10} extinction coefficient, where $\epsilon = A/cl$)).

I. Synthetic Dehydration Standards.

1. γ -(3-pyrenoyl)-proprionic acid (I)⁶⁶

Nitrobenzene was distilled under vacuum from P₂O₅. A 2 L flask equipped with stirring motor and thermometer was charged with 24.74 g (.247 mole) of succinic anhydride dissolved in 300 mL of nitrobenzene. 66 g (.495 mole) of AlCl₃ was added slowly, and the reaction mixture cooled to between 0° and 5°. 50 g (.247 mole) of pyrene was added in small portions over a period of 40 minutes, with the temperature maintained at between 0° and 5°. The mixture was then allowed to stir for 18 hours at room temperature. The reaction mixture was hydrolyzed by the addition of 500 g of ice plus 50 mL of concentrated HCl. Nitrobenzene was removed by steam distillation, and the crude product

isolated by filtration. This material was dissolved in hot ethanol-KOH (70% ethanol-8% KOH) and filtered. The keto-acid was precipitated by addition of acetic acid, isolated by filtration, and recrystallized from acetic acid. Yield 67.3 g (90%), mp 185° (lit. 182-183°).⁶⁶

NMR: (d_6 -DMSO) 2.76(2H_γ), 3.48(2H_β), 8.1-8.78(9 aromatic), 12.1 (-COOH); $J_{\beta,\gamma}$ = 6.1 Hz. MS: m/z 302(165), 284(203), 256(94), 229(1000), 201(692), 115(53), 101(140). UV: (nm) 385(3.82), 352(4.37), 280(4.41), 242(4.64), 233(4.59).

Anal. Calcd. for C₂₀H₁₄O₃: C, 79.45; H, 4.67; Found: C, 78.14
H, 4.78.

2. 4-(pyrenoyl)-butanoic acid (II)

74.9 g (.247 mole) of keto-acid I was placed in a 1 L flask equipped with a condenser and magnetic spin-bar. 360 mL of 2,2'-dioxoethanol, 47.3 g (3.4 molar equivalents) of KOH, and 34 mL of hydrazine hydrate (35 g, 2.8 molar equivalents) were added, and the mixture heated at 120° for 1.5 hours. The temperature was then raised slowly to 230° as excess water distilled off. After reaching 230°, the reaction mixture was allowed to reflux for 5 hours, and then cooled to room temperature. The reaction mixture was adjusted to pH = 1 by addition of 20% HCl, and the product filtered off. The crude product was dried in vacuo and then recrystallized from xylene. Yield 53.5 g (75%), mp 187-188° (lit. 184-186°).⁶⁶ NMR: (d_6 -DMSO) 2.02(2H₃), 2.42(2H₄), 3.35 (2H₂), 7.9-8.40 (9 aromatic), 12.0 (-COOH); $J_{2,3}$ = 7.32, $J_{3,4}$ = 6.7 Hz. MS: m/z 288(372), 228(117), 226(106), 215(1000), 213(170), 189(202), 187(106), 60(470). UV: absorption spectrum is that of pyrene, shifted to longer wavelengths by ≈ 6 nm: 378(2.79), 344(4.79), 328(4.59), 314 (4.19), 302(3.79), 280(4.80), 266.5(4.54), 245(5.05), 236(4.79).

3. 7-oxo-7,8,9,10-tetrahydrobenzo(a)pyrene (III)

A 2 L flask equipped with a stirring motor was charged with 25 g (87 mmol) of II in 650 mL of benzene. 22.6 g (1.25 molar equivalents) of PCl_5 was then added in small portions over a period of 1 hour. This mixture was refluxed for 1 hour and then cooled to 15° . 28.24 g (1.25 molar equivalents) of SnCl_4 in 25 mL of benzene was added dropwise, and stirring continued overnight. After 18 hours, dilute HCl and ice were added to hydrolyze the reaction mixture. After 2 hours, 1.2 L of benzene was added and the benzene solution washed with 10% sodium carbonate and water. The benzene solution was dried over K_2CO_3 and the solvent removed on a rotary evaporator. The residue was recrystallized from benzene (yellow plates). Yield 16.4 g (70%), mp $169-170.5^\circ$ (lit. $173-175^\circ$). ⁶⁶ NMR: (CDCl_3) 2.40(2H_9), 2.86(2H_8), 3.56(2H_{10}), 7.35-8.80 (8 aromatic; $\text{H}_6 = 8.80 \delta$); $J_{9,10} = 6.1$, $J_{8,9} = 6.7$ Hz. MS: m/z 270(1000), 241(124), 239(179), 226(172), 214(813); UV: 345(4.52), 329(4.29), 316(3.88), 297(4.29), 277.5(4.79); IR: C=O stretch at 1675 cm^{-1} .

Anal. Calcd. for $\text{C}_{20}\text{H}_{14}\text{O}$: C, 88.86; H, 5.22; Found: C, 88.64; H, 5.37.

4. 7-hydroxy-7,8,9,10-tetrahydrobenzo(a)pyrene(IV)

9.85 g (36.4 mmol) of ketone III was placed in a 3 L flask together with 660 mL of methanol. 1.72 g (45 mmol) of sodium borohydride in 100 mL of methanol was added dropwise with vigorous stirring, followed by 400 mL of ether. After 4 hours an additional 280 mg (≈ 7 mmol) of sodium borohydride in 30 mL of methanol was added, and stirring continued for 12 hours. 500 mL saturated sodium chloride was then added, followed by 400 mL of ether. The ether phase was washed with water, dried over K_2CO_3 , and concentrated to a small volume on a rotary

evaporator. The product crystallized on cooling. Yield 8.75 g (88%), mp 135-137° (lit. 135-136°).⁶⁶ NMR: (d_6 -DMSO) 1.89(2H₉), 2.12(2H₈), 3.38(2H₁₀), 5.0(H₇), 5.4(C₇-OH), 7.99-8.38(8 aromatic); $J_{7,8}$ = 5 Hz. MS: m/z 272(52), 254(1000), 252(651), 239(211), 126(197); UV: 345 (4.52), 329(4.29), 316(3.88), 297(4.29), 277.5 (4.79), 267(5.00), 245(4.75); IR: OH stretch at ≈ 3220 cm⁻¹; no C=O stretch.

Anal. Calcd. for C₂₀H₁₆O: C, 88.2; H, 5.92; Found: C, 86.25, H, 6.17.

5. 9,10-dihydrobenzo(a)pyrene (V)

1.06 g (3.89 mmol) of alcohol IV was dissolved in 200 mL of benzene, and then 204 mg (.275 molar equivalents) of p-Toluenesulfonic acid (p-TsOH) was added. This mixture was refluxed for 25 minutes, cooled, and extracted with 10% sodium bicarbonate solution. The benzene solution was washed with water, dried over K₂CO₃, and the benzene removed on a rotary evaporator. The residue was dissolved in the minimum volume of benzene and applied to a 4 x 30 cm column of neutral Alumina (Woelm grade 1). The column was eluted with benzene and the green fluorescent band (exc. 350 nm) was collected. Evaporation of solvent gave off-white crystals. Yield 885 mg (89.5%), mp 146-148° (lit. 146-147°).⁶⁵ HPLC (reverse phase) showed a single peak, with no evidence of any contaminating benzo(a)pyrene. NMR: (CDCl₃) 2.59(2H₉), 3.50 (2H₁₀), 6.29(H₈), 6.86(H₇), 8.28-7.86(8 aromatic); $J_{9,10}$ = 8.3 Hz. MS: m/z 254(1000), 252(672), 239(224), 126(202). UV: 384(3.40), 346 (4.40), 330(4.15), 316(3.88), 299(4.33), 279(4.71).

Anal. Calcd. for C₂₀H₁₄: C, 94.45; H, 5.55; Found: C, 94.20, H, 5.52.

6. 7,8,9,10-tetrahydrobenzo(a)pyrene (VI)⁶⁸

A 100 mL flask was charged with 5.08 g (19 mmol) of ketone III, 3.43 g (61 mmol) of KOH, 3.3 mL (68 mmol) of hydrazine hydrate, and 60 mL of 2,2'-oxydiethanol. This mixture was heated at 100° for 1.5 hours, and then heated slowly to 240° and maintained at this temperature for 5 hours. After cooling, 50 mL of 2.5 M HCl was added and the resulting precipitate filtered and washed. This crude product was recrystallized from ethanol, dissolved in the minimum volume of benzene, and applied to a 4.5 x 20 cm column of neutral Alumina (Woelm grade 1). Elution with benzene gave a fast-moving green fluorescent band; evaporation of solvent in vacuo resulted in colorless crystals. Yield 3.86 g (80%), mp 112-113°. NMR: (CDCl₃, 270 MHz) 3.22 (2H₁₀), 3.06(2H₇), 1.88-1.90(2H₈,2H₉), 7.68-8.02(8 aromatic). MS: m/z 256(1000), 252(105), 239(207), 228(423), 120(137). UV: 378 (3.25), 345(4.86), 328(4.63), 315(4.48), 302(3.73), 279(4.82), 268 (4.60), 246(5.10), 238(4.87).

7. 10-acetoxy-7,8,9,10-tetrahydrobenzo(a)pyrene (VII)⁶⁸

A 500 mL flask was charged with 3.86 g (15 mmol) VI, 7.75 g (17 mmol) of lead tetra-acetate (Pb(OAc)₄, freshly prepared), 165 mL of benzene, and 110 mL of acetic acid. This mixture was heated at 60° with stirring for 7 hours. After cooling, 12 mL of ethylene glycol was added, followed by 100 mL of water. The benzene solution was washed with 10% ammonia followed by water, dried over K₂CO₃, and the solvent removed in vacuo. The resulting red oil crystallized on standing. The crude product was recrystallized from ethanol. Yield 3.1 g (67%), mp 174-175° (lit. 174-175°).⁶⁸ NMR: (CDCl₃) 1.85- 2.60

(4H_{8,9}), 2.60(acetate), 3.02-3.45(2H₇), 6.88(H₁₀), 7.66-8.23(8 aromatic); J_{9,10} = 3 Hz. MS: m/z 314(62), 270(91), 255(543), 254(1000), 252(773), 239(650), 228(109), 226(174). UV: 377(2.85), 344(4.75), 327(4.55), 314(4.15), 302(3.76), 278.5(4.77), 267(4.51), 257(4.21), 246(5.01), 236(4.75).

8. 10-hydroxy-7,8,9,10-tetrahydrobenzo(a)pyrene (VIII)⁶⁵

800 mg (2.5 mmol) of VII was dissolved in 250 mL of 5% KOH-methanol and refluxed for 30 minutes. 100 mL of benzene plus 100 mL of water were added, and the separated benzene solution washed twice with water. The benzene solution was dried over K₂CO₃ and the solvent removed on a rotary evaporator. The crude product was recrystallized from benzene. Yield 620 mg (90%), mp 182-184° (lit. 182-184°)⁶⁵.

NMR: (d₆-DMSO) 1.89(2H₈), 2.20(2H₉), 3.20(2H₇), 5.10(H₁₀), 5.30(C₁₀-OH), 7.99-8.38(8 aromatic). MS: m/z 272(100), 254(1000), 239(485), 126(243). UV: 377(2.19), 343(4.52), 326(4.31), 313(3.86), 301(3.19), 279(4.46), 267(4.21), 257(3.84), 246(4.76), 237(4.47).

9. 7,8-dihydrobenzo(a)pyrene (IX)⁶⁵

3 g (11 mmol) of alcohol VIII was refluxed in 500 mL of benzene together with 580 mg p-TsOH for 30 minutes. The benzene solution was washed once with 10% sodium bicarbonate and twice with water, dried over K₂CO₃, and concentrated to the minimum volume on a rotary evaporator. This solution was then applied to a 5 x 40 cm column of neutral Alumina (Woelm grade 1) and eluted with benzene. The fast-moving green fluorescent band (exc. 350 nm) was collected. Evaporation of solvent and cooling gave yellow plates. Yield 2.5 g (90%), mp 129-130° (lit. 129-130°)⁶⁵. HPLC (reverse phase) showed a single peak, with no

evidence of contamination by either benzo(a)pyrene or 7,8,9,10-tetrahydrobenzo(a)pyrene. NMR: (CDCl_3) 2.47(2H_8), 3.18(2H_7), 6.38(H_9), 7.50(H_{10}), 7.88-8.32(8 aromatic); $J_{9,10} = 9.76$ Hz, $J_{7,8} = 8.3$ Hz.

MS: m/z 254(1000), 252(797), 239(458), 226(123). UV: 393(3.47), 366(4.61), 347(4.57), 331(4.45), 317(3.95), 293(4.46), 281(4.47), 268(4.29), 255(4.64), 247(4.67), 225(4.61).

10. (+)-cis-7,8-dihydroxy-7,8,9,10-tetrahydrobenzo(a)pyrene (X)⁶⁵

A 100 mL flask was charged with 502 mg (1.97 mmol) of 9,10-dihydrobenzo(a)pyrene (V) in 8 mL of pyridine. 0.5 g (1.97 mmol) of osmium tetroxide in 2 mL of pyridine was added, and the solution stirred for 24 hours. The osmate ester was hydrolyzed by adding a solution consisting of 1 g sodium bisulfite, 7.5 mL pyridine, and 15 mL water. After 2 hours, 50 mL of chloroform was added and the resulting chloroform solution washed three times with water, dried over K_2CO_3 , and the solvent removed under vacuum. The crude diol was recrystallized from THF-methanol. Yield 467 mg (82%), mp 210-211° (lit. 212-213°)⁶⁵. NMR: (d_6 -DMSO) 3.36(2H_9), 3.45(2H_{10}), 4.09(H_8), 4.75(H_7), 4.90($\text{C}_8\text{-OH}$), 5.27($\text{C}_7\text{-OH}$), 7.86-8.52(8 aromatic); $J_{7,8} = 3$ Hz. MS: m/z 288(43), 270(1000), 242(136), 228(734), 226(319). UV: 344(4.64), 327(4.46), 314(4.05), 302(3.70), 277(4.68), 266(4.42), 256(4.14), 246(4.93), 236(4.70).

11a. (+)-7,8-epoxy-7,8,9,10-tetrahydrobenzo(a)pyrene (XV)⁶⁹

A 250 mL flask was charged with 1 g (3.93 mmol) of V in 75 mL of dichloromethane plus 30 mL of .05 M sodium bicarbonate solution. 680 mg (1 molar equivalent) of m-chloroperbenzoic acid in 25 mL of methylene chloride was added dropwise over a period of 15 minutes. After 24 hours, the methylene chloride solution was washed with water, dried

over K_2CO_3 , and the solvent removed on a rotary evaporator. The crude product was recrystallized from THF-petroleum ether. Yield 795 mg (75%), mp 175-176° (lit. 172-175°)⁶⁹. NMR: ($CDCl_3$) 3.36($2H_9$), 3.45 ($2H_{10}$), 3.50(H_8), 4.80(H_7), 7.86-8.52(8 aromatic). MS: m/z 270(1000), 239(256), 228(687), 226(352). UV: 382(2.21), 342(4.64), 327(4.46), 312 (4.06), 300(3.70), 280(4.68), 268(4.42), 251(4.12), 242(4.93).

11b. 8-oxo-7,8,9,10-tetrahydrobenzo(a)pyrene (XI)⁶⁵

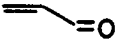
103 mg (0.38 mmol) of XV was refluxed with 15 mg of p-TsOH in 15 mL of benzene for 90 minutes. The reaction mixture was washed with 10% sodium bicarbonate and water, dried over K_2CO_3 , and the solvent removed on a rotary evaporator. The residue was redissolved in benzene and applied to a 2.3 x 18 cm neutral Alumina column (Woelm grade 2). Elution with benzene gave two fractions; the second band on evaporation gave ca. 60 mg of colorless crystals. Yield 60 mg (60%), mp 179-182° (lit. 180-181°).⁶⁵ NMR: ($CDCl_3$) 2.70($2H_9$), 3.60($2H_7$), 3.70($2H_{10}$), 7.70-8.29(8 aromatic); $J_{9,10} = 7$ Hz. MS: m/z 270(1000), 228(865), 215(15); the fragment at m/z 228 corresponds to loss of $CH_2=C=O$, and m/z 215 corresponds to loss of  (55 mass units). The low relative abundance of mass 215 (1.5%) is characteristic of an unconjugated ketone. The intensity of these two fragments (m/z 228 and 215) is reversed for 7-oxo-7,8,9,10-tetrahydrobenzo(a)pyrene (III) and for 10-oxo-7,8,9,10-tetrahydrobenzo(a)pyrene (XIV). UV: identical to 7,8,9,10-tetrahydrobenzo(a)pyrene (VI), with no evidence of conjugation between the ketone and the aromatic system; 378(2.83), 342(4.34), 327 (4.15), 312(3.78), 300(3.30), 279(4.30), 268(4.08), 257(3.83), 248(4.60), 238(4.37). IR: C=O stretch at 1710 cm^{-1} ; III has the C=O stretch at 1675 cm^{-1} .

12. (+)-cis-9,10-dihydroxy-7,8,9,10-tetrahydrobenzo(a)pyrene (XII)⁶⁵

0.5 g (1.96 mmol) of 7,8-dihydrobenzo(a)pyrene (IX) in 10 mL of pyridine was treated with 0.5 g of osmium tetroxide (OsO_4) and the resulting solution stirred for 40 hours. A solution of 1 g sodium bisulfite, 7.5 mL pyridine, and 15 mL water was added; after 2 hours 50 mL of chloroform was added. The chloroform solution was washed with water, dried over K_2CO_3 , and the solvent removed on a rotary evaporator. The crude product was recrystallized from THF-methanol. Yield 390 mg (69%), mp 208-210° (lit. 208-210°)⁶⁵. NMR: (d_6 -DMSO) 3.21 (2H₇), 3.38(2H₈), 4.13(H₉), 5.01(H₁₀), 4.91(C₉-OH), 5.40(C₁₀-OH), 7.86-8.52(8 aromatic); $J_{9,10} = 3$ Hz. MS: m/z 288(792), 270(1000), 254(379), 252(372), 228(425), 226(542), 215(961), 202(258). UV: 376(2.30), 342.5(4.64), 328(4.46), 313(4.05), 300(3.70), 278(4.68), 267(4.42), 256(4.14), 246(4.93), 236(4.70).

13. 9-oxo-7,8,9,10-tetrahydrobenzo(a)pyrene (XIII)⁶⁵

300 mg (1.04 mmol) of cis-diol XII was dissolved in 10 mL of acetic acid plus 1 drop of HCl and heated at 90° for 30 minutes. The product was precipitated by addition of water, filtered, and redissolved in benzene. TLC at this point indicated the presence of one major component (R_f 0.19), and five minor components. 100 mg of the crude product was separated by preparative HPLC (Whatman 10 μ silica, 9.2 mm x 50 cm), using hexane-methylene chloride as eluant. The major component (\approx 70% of total) was collected to give ca. 60 mg of colorless crystals. mp 175-177° (lit. 175-177°)⁶⁵. NMR: (CDCl_3) 2.41(2H₈), 2.93(2H₇), 3.68(2H₁₀), 7.31-8.21(8 aromatic); $J_{7,8} = 7$ Hz. MS: m/z 270(1000), 242(594), 241(795), 228(344), 215(13), 213(144), 120(129); relative intensities

of m/z 228 and 215 are similar to that found for 8-oxo-7,8,9,10-tetrahydrobenzo(a)pyrene (XI). IR: similar to XI, with C=O stretch at 1710 cm^{-1} . UV: identical to 7,8,9,10-tetrahydrobenzo(a)pyrene (VI); 379(2.84), 345(4.41), 328(4.23), 301(3.54), 278(4.42), 267(4.23), 257(4.07), 247.5(4.66), 238(4.49).

14. 10-oxo-7,8,9,10-tetrahydrobenzo(a)pyrene (XIV)

142 mg (0.52 mmol) of alcohol VIII was dissolved in 18 mL of anhydrous dimethyl sulfoxide (DMSO), and then 1 mL of acetic anhydride was added. After 12 hours, 11 mL of water was added, followed by 20 mL of ammonium hydroxide. 30 mL of benzene was then added, and the resulting benzene solution was washed with water, dried over K_2CO_3 , and the solvent removed on a rotary evaporator. TLC revealed two products (R_f 0.29 and 0.40). Chromatography on neutral Alumina (Woelm grade 1) gave two fractions (F1 and F2, present in approximately equal amounts). F1 was shown by its absorption spectrum, mass spectrum, and HPLC retention time to be 7,8-dihydrobenzo(a)pyrene (IX). This material is apparently formed via abstraction of the 9-hydrogen rather than the 10-hydrogen by the intermediate alkoxyulfonium ylid:

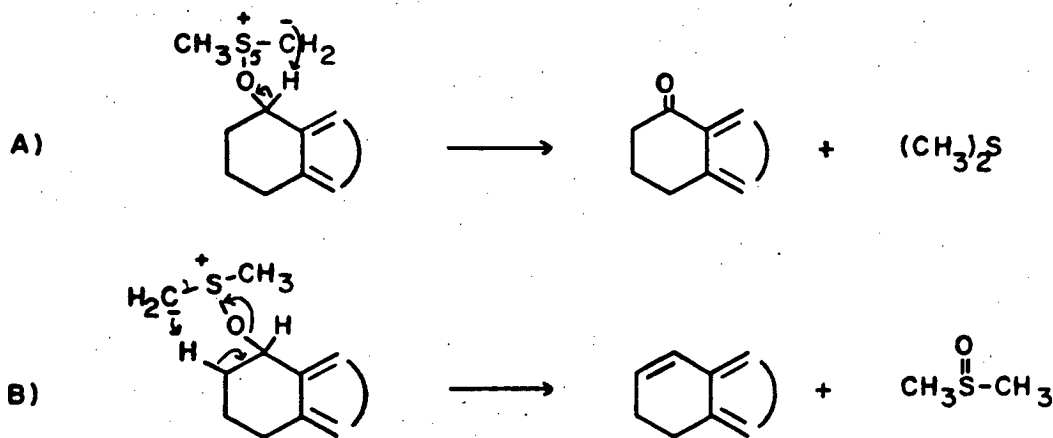

Reaction B is probably enhanced by the severe steric hindrance present

in the "bay" 10-position.

F2 (ca. 30% of total product) had an infra-red spectrum similar to III, indicating a carbonyl in conjugation with an aromatic system (C=O stretch at 1655 cm^{-1}) ; mp $173\text{-}174^\circ$ (lit. $174\text{-}175^\circ$).¹⁰⁷ NMR: (CDCl_3) 2.25(2H₈), 2.91(2H₇), 3.31(2H₉), 7.80-8.40(8 aromatic); $J_{7,8} = 7\text{ Hz}$, $J_{8,9} = 7\text{ Hz}$. UV: (similar to keto-acid I) 400(4.32), 358(4.51), 293(4.57), 282(4.35), 250(4.63), 236(4.82).

15. (+) 8-hydroxy-7,8,9,10-tetrahydrobenzo(a)pyrene (XVI)⁶⁹

10 mg (0.37 mmol) of ketone XI was reduced with 15 mg of NaBH_4 in 40 mL of methanol. After four hours, 50 mL of ether plus 50 mL of saturated sodium chloride were added. The ether layer was washed with water, dried over K_2CO_3 , and the solvent removed on a rotary evaporator. The crude product was purified by HPLC (Micropak C-10 reverse phase), using water-methanol as eluant. The purified product had acceptable UV, IR, and mass spectra. MS: m/z 272(839), 254(818), 252(516), 239(690), 226(522). IR: similar to IV; 3250, 3030, 2900, 1050 cm^{-1} ; no absorption bands present over the region $1650\text{-}1800\text{ cm}^{-1}$. UV: identical to IV: 378(2.19), 344(4.52), 328(4.31), 314(3.86), 302(3.19), 278(4.46), 266.5(4.21), 245(4.76), 236(4.47).

16. (+) 9-hydroxy-7,8,9,10-tetrahydrobenzo(a)pyrene (XVII)⁶⁹

10 mg (0.37 mmol) of ketone XIII was reduced with 15 mg of NaBH_4 in 40 mL of methanol. After 2 hours, 50 mL of ether plus 50 mL of saturated sodium chloride were added. The ether layer was washed with water, dried over K_2CO_3 , and the solvent removed on a rotary evaporator. The crude product was purified by HPLC (Micropak C-10 reverse phase, eluted with water-methanol). The purified product had acceptable UV, IR, and mass spectra. MS: similar to XVI; m/z 272(310), 254(1000),

252(601), 239(555). IR: similar to IV and to XVI; 3250, 3030, 2900, 1050 cm^{-1} ; no absorption bands present over the region 1650-1800 cm^{-1} .

UV: identical to IV and to XVI; 378(2.20), 344(4.52), 328(4.31), 314 (3.86), 302(3.19), 278(4.46), 266(4.21), 245(4.76), 236(4.47).

17. (+)*cis*-4,5-diacetoxy-4,5-dihydrobenzo(a)pyrene (XVIII)⁷³

A 100 mL flask was charged with 1 g (3.96 mmol) of benzo(a)pyrene (Aldrich) in 10 mL of pyridine. 1 g (3.94 mmol) of osmium tetroxide (OsO_4) in 10 mL of pyridine was added, and the solution stirred for 96 hours. The osmate ester was hydrolyzed by addition of 2 g sodium bisulfite, 15 mL pyridine, and 30 mL water. After 2 hours, 100 mL of chloroform was added and the resulting chloroform solution washed with water. Removal of solvents under vacuum yielded the cis-diol (m/z 286); this was treated with 40 mL of acetic anhydride plus 4 mL of pyridine for 12 hours. Excess acetic anhydride was then hydrolyzed with ice water, and the precipitated product collected by filtration. The crude diacetate was purified by chromatography on Florisil. Elution with hexane yielded a small amount of unreacted benzo(a)pyrene, and elution with benzene gave the cis-diacetate. Yield 880 mg (60%), mp 214-215° (lit. 214-215°).⁷⁴ NMR: (CDCl_3) 1.93(- CH_3), 2.00(- CH_3), \approx 6.44 (H_4 and H_5), 7.10-8.65(10 aromatic). MS: m/z 370(213), 327(195), 310 (545), 267(643), 239(1000). UV: similar to chrysene; 324(3.35), 310 (3.39), 296(3.49), 272(4.37), 263(4.18), 244(3.65), 222(3.85).

18. Benzo(a)pyrene quinones: (1,6), (3,6), and (6,12)⁷⁵

A 100 mL flask was charged with 1 g (3.96 mmol) of benzo(a)pyrene (Aldrich) in 20 mL of acetic acid. This solution was cooled to 5°, and then 1.46 g (14.6 mmol) of CrO_3 in 4 mL of water was added. The mixture was stirred for 15 minutes, and then refluxed for 30 minutes. After

cooling, a precipitate of red-brown crystals was collected, washed with water, and chromatographed on neutral Alumina (Woelm grade 3). Elution with benzene and then benzene acetic acid (20% v/v) gave a mixture of (1,6), (3,6), and (6,12) quinones (three partially resolved peaks on HPLC, using reverse phase Micropak C-10). Yield 895 mg ($\approx 80\%$), mp 280-285°. MS: m/z 282(1000), 254(281), 236(278), 224(172), 113(300). IR: intense band at 1645- 1650 cm^{-1} . UV: 475-400(4.27), 294 (3.61), 250(4.45), end absorption below 230 nm.

II. Diol Epoxide Synthesis

19. (+)trans-7,8-dibenzoyl-7,8,9,10-tetrahydrobenzo(a)pyrene (XIX)

[anhydrous conditions are essential to the success of this reaction]

Silver benzoate was prepared by dissolving 8 g of benzoic acid in 100 mL of water plus 4 mL of concentrated ammonium hydroxide at 70°. This solution was filtered, cooled to 50°, and then 11.12 g of silver nitrate in 65 mL of water was added to it. The mixture was diluted with 500 mL of water and filtered. The silver benzoate precipitate was collected and dried in a vacuum oven at 105° for 24 hours. Benzene was distilled from P_2O_5 under nitrogen.

2.939 g (11.5 mmol) of 9,10-dihydrobenzo(a)pyrene (V) was dissolved in 100 mL of benzene, and ca. 30 mL distilled off to remove any residual water in the starting material.

A 2 L flask equipped with stirring motor and reflux condenser was charged with 5.3 g of silver benzoate (2.31 mmol) plus 2.93 g of iodine (11.5 mmol) in 730 mL of benzene. After 15 minutes the 9,10-dihydrobenzo(a)pyrene in 200 mL of benzene was added, and stirring

continued for 15 minutes. The reaction mixture was then refluxed for 6.5 hours, and stirring continued overnight at room temperature. Precipitated silver iodide was removed by filtration, and the benzene solution washed with water, sodium carbonate, sodium thiosulfate, and water. The benzene solution was dried over K_2CO_3 and the solvent removed on a rotary evaporator. The residue was recrystallized from acetone. Yield 3.73 g (65%), mp 206-207° (lit. 215-216°).⁹⁹ NMR: ($CDCl_3$) 2.36-2.68($2H_9$), 3.74($2H_{10}$), 5.78(H_8), 6.99(H_7), 7.32-7.59(10 phenyl aromatic), 7.93-8.33(8 aromatic); $J_{7,8} = 5.86$ Hz, $J_{9,10} = 6.3$ Hz (the small value for $J_{7,8}$ indicates a trans-diaxial conformation for the benzoyl groups). MS: m/z 496(43), 374(109), 269(62), 252(1000), 105(297). UV: similar to VI; 380(3.01), 345(4.71), 329(4.51), 315(4.16), 302(3.82), 279(4.72), 268(4.51), 257(4.21), 248(4.99).

Anal.: Calcd. for $C_{34}H_{24}O_4$: C, 82.24; H, 4.87; Found: C, 81.36;
H, 4.92.

20. 10-bromo-trans-7,8-dibenzoyl-7,8,9,10-tetrahydrobenzo(a)pyrene
(XX)

1.096 g (2.2 mmol) of XIX was dissolved in 500 mL of CCl_4 and placed in a water-jacketed photochemical reactor equipped with a magnetic spin-bar and a sintered-glass argon inlet. The system was purged for 10 minutes, and then 425 mg of N-bromosuccinimide (NBS) [1.08 molar equivalents] plus 2 mg azo-bis-isobutyryl nitrile (AIBN) were added. 50° water was circulated through the jacket, and the reaction mixture was irradiated with a 150 W sun lamp for 30 minutes. After 50 minutes, the reaction mixture was cooled to 0° and the precipitated succinimide was filtered off. Solvent was removed on a rotary evaporator, and the residue recrystallized from benzene.

Yield 890 mg (70%), mp 114° dec. (lit. 118° dec.).⁹⁹ NMR: (CDCl₃) 2.63, 3.18 (2H₉), 6.34(H₈), 7.05(H₁₀), 7.12(H₇), 7.27-7.61 (10 phenyl aromatic), 7.61-8.82(8 aromatic); J_{7,8} = 6 Hz. MS: m/z 372(1000), 122 (60); (material probably undergoes thermal dehydrohalogenation in the ion source of the mass spectrometer). UV: 366(3.00), 344(4.67), 327(4.49), 314(4.13), 301(3.80), 278(4.70), 267(4.48), 256(4.19), 248(4.96), 238(4.70).

Anal. Calcd. for C₃₄H₂₃O₄Br: C, 70.96; H, 4.03; Br, 13.89

Found: C, 69.85, H, 4.11, Br, 14.42 .

21. (+trans-7,8-dibenzoyl-7,8-dihydrobenzo(a)pyrene (XXI)

2.612 g (4.54 mmol) of XX in 400 mL xylene was placed in a 1 L flask and refluxed for 10 minutes under argon. After cooling, xylene was removed on a rotary evaporator, and the residue recrystallized from acetone. Yield 1.8 g (80%), mp 190-192° (lit. 196-198°).⁹⁹

NMR: (CDCl₃) 6.16(H₈), 6.41(H₉), 7.00(H₇), 7.68(H₁₀), 7.23-7.32(phenyl H), 7.73-8.50(aromatic H); J_{7,8} = 7 Hz, J_{9,10} = 10 Hz. MS: m/z 372(98), 252(173), 122(95), 105(1000); m/z 372 presumably arises via β-rearrangement:

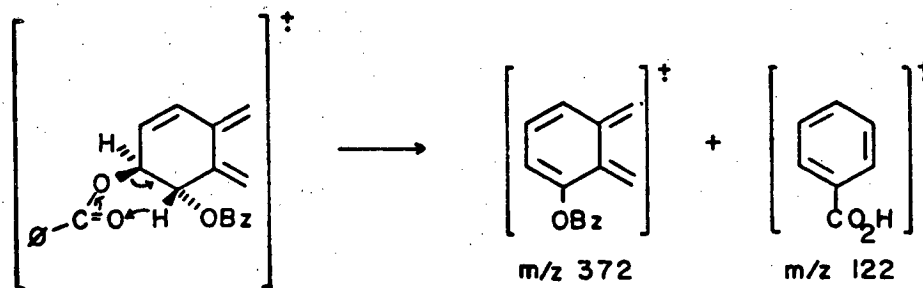

UV: similar to 7,8-dihydrobenzo(a)pyrene (IX); 400(3.51), 366.5(4.70), 348.5(4.56), 330(4.20), 318(3.82), 292.5(4.44), 281(4.39), 257(4.70), 237(4.69). Anal. Calcd. for C₃₄H₂₂O₄: C, 82.6; H, 4.65

Found: C, 81.12; H, 4.94 .

22. (+)-trans-7,8-dihydroxy-7,8-dihydrobenzo(a)pyrene (XXII)

1.86 g (3.76 mmol) of XXI in 200 mL of THF plus 546 mg of sodium methoxide in 65 mL of methanol was refluxed for 10 minutes and then cooled. The reaction mixture was diluted with 600 mL of ether and washed with water. The water wash was extracted with 650 mL of ether; then the ether phases were combined and washed with three volumes of water. The ether solution was dried over K_2CO_3 and concentrated to a small volume; on cooling to -40° the product crystallized as white plates. Yield 807 mg (75%), mp 208° dec. NMR: (d_6 -DMSO) 4.48(H_8), 4.95(H_7), 5.45(C_8 -OH), 5.87(C_7 -OH), 6.26(H_9), 7.47(H_{10}), 7.93-8.48 (8 aromatic); [d_8 -THF]: $J_{7,8} = 10$ Hz, $J_{9,10} = 6$ Hz. MS: m/z 286(330), 268(1000), 239(799). UV: similar to 7,8-dihydrobenzo(a)pyrene (IX); 393(3.47), 365(4.63), 347(4.61), 330(4.47), 316(4.04), 292(5.01), 280(4.50), 279(4.31), 254(4.65), 247(4.64).

HRMS: M^+ at m/z 286.098234; calcd. for $C_{20}H_{14}O_2$, 286.099383
(-4 ppm error).

23. (+)-r-7, t-8-dihydroxy-t-9,10-oxy-7,8,9,10-tetrahydrobenzo(a)-pyrene (XXIV)

160 mg (0.56 mmol) of diol XXII was dissolved in 50 mL of THF (redistilled over $LiAlH_4$ and stored under nitrogen) and 172 mg of 100% m-chloroperbenzoic acid added. The reaction mixture was allowed to stir at room temperature, and 2 μ L aliquots were periodically withdrawn to monitor the progress of the reaction by absorption spectroscopy. After 8 hours, the UV-absorption spectrum changed from that of a 7,8-dihydrobenzo(a)pyrene to that of 7,8,9,10-tetrahydrobenzo(a)pyrene. 250 mL of ether was added, and the reaction mixture washed with

10% sodium sulfite, 10% sodium bicarbonate, and water. The ether solution was dried over K_2CO_3 , concentrated to a small volume, and cooled to -40° . The product crystallized as white needles. Yield 118 mg (70%), mp 214° (lit. 214°). NMR: (d_6 -DMSO) 3.95(H_9), 4.04(H_8), 4.86(H_7), 5.18(H_{10}), 5.88(C_8 -OH), 6.01(C_7 -OH), 7.95-8.30(6 aromatic), 8.60(H_6), 8.68(H_{11}); $J_{9,10} = 4.5$ Hz, $J_{7,8} = 8.6$ Hz; [d_8 -THF]: 2.47 (C_8 -OH), 2.51(C_7 -OH); $J_{9,10} = 5.1$ Hz, $J_{7,8} = 8.82$ Hz. The large value for $J_{7,8}$ in both solvents indicates that the hydroxyl groups are pseudo-equatorial. MS: derivatization was necessary to increase volatility: 1 mg of XXIV was dissolved in 50 μ L of N,N-dimethylformamide and then treated with 80 μ L of BSTFA (N,O-bis-trimethylsilyltrifluoroacetamide) [Pierce Chemical Co., Rockford, Illinois]. After 3 hours the reagent and solvent were evaporated in a stream of dry nitrogen, and the residue redissolved in 1 mL of methylene chloride. The mass spectrum of this material had a molecular ion at m/z 446(233), and fragment peaks at m/z 356(839), 341(1000), 328(985), 255(227), 239(563), 191(519), and 147(458). UV: similar to 7,8,9,10-tetrahydrobenzo(a)pyrene (VI); 344(4.64), 328(4.46), 313(4.05), 301(3.70), 279(4.68), 268(4.42), 258(4.14), 247(4.93), 238(4.70) [solvent, THF].

HRMS: M^+ at m/z 446.172021; calcd. for $C_{20}H_{12}O_3TMS_2$, 446.173359 (-3 ppm error).

Hydrolysis of XIV in aqueous THF gave two products separable by HPLC, identified as 7,8,9,10-tetrahydroxy-7,8,9,10-tetrahydrobenzo(a)pyrenes by the mass spectra of their permethyl ethers (m/z 376) [see chapters 4 and 5 for a discussion of the stereochemistry of these isomers].

24. (+) r-7,t-8,r-10-trihydroxy-t-9-bromo-7,8,9,10-tetrahydrobenzo-
(a)pyrene (XXIII)^{98,101}

N-Bromoacetamide was recrystallized from chloroform-hexane. 306 mg (1.0 mmol) of diol XXII was dissolved in 50 mL of THF-water (80:20 v/v), and 162 mg (1.17 mmol) of N-bromoacetamide added. This mixture was allowed to stir for 8 hours, at which time the UV-absorbtion spectrum of an aliquot had changed from a 7,8-dihydrobenzo(a)pyrene chromophore to that of a 7,8,9,10-tetrahydrobenzo(a)pyrene. Ether was added and the resulting solution washed with water, dried over K_2CO_3 , and concentrated. The product was recrystallized from THF-ethanol. Yield 348 mg (85%), mp 126-128° dec. (lit. 128-130° dec.).¹⁰¹ NMR: (d_6 -DMSO) 4.31(H_8), 4.82(H_9), 4.95(H_7), 5.59(H_{10}), 5.88(C_8 -OH), 6.11(C_7 -OH), 6.50 (C_{10} -OH), 7.95-8.64(8 aromatic); $J_{7,8} = 10.0$ Hz; $J_{9,10} = 3.0$ Hz; $J_{8,9} = 3.0$ Hz. MS: m/z 364, 366 (M^+ - H_2O , 1:1 Br isotope pattern); UV: 378 (3.02), 345(4.67), 328(4.49), 314(4.13), 302(3.80), 278(4.71), 267 (4.47), 257(4.19), 247(4.96), 237(4.70).

25. (+) r-7,t-8-dihydroxy-r-9,10-oxy-7,8,9,10-tetrahydrobenzo(a)-
pyrene (XXV)¹⁰³

210 mg (0.54 mmol) of bromohydrin XXIII was dissolved in 25 mL of THF (redistilled over $LiAlH_4$ and stored under nitrogen) and cooled to 15°. 68 mg (1.1 molar equivalents) of potassium t-butoxide (KO/t-Bu) was added, and the resulting orange solution stirred for 1 hour at 15°. 200 mL of ether was added, followed by 200 mL of water. The ether solution was washed two additional times with water, dried, and the solvent removed on a rotary evaporator. The product crystallized at -40° as off-white needles. Yield 100 mg (60%), mp 220° dec. (lit. 226-228° dec.)

NMR: (d_6 -DMSO) 3.88(H_9), 4.01(H_8), 4.96(H_7), 4.98(H_{10}), 5.86(C_8 -OH), 5.24(C_7 -OH), 8.1-8.50(7 aromatic), 8.62(H_{11}); $J_{9,10} = 4.1$ Hz; $J_{7,8} = 5.8$ Hz. The upfield shift for C_7 -OH is indicative of intramolecular hydrogen bonding to the epoxide.¹⁰² MS: derivatization with DMF-BSTFA as described for XXIV resulted in a mass spectrum essentially identical to that observed for diol epoxide XXIV (M^+ at m/z 446). UV: identical to XXIV; 344(4.64), 328(4.46), 313(4.05), 301(3.70), 279(4.68), 268(4.42), 258(4.14), 247(4.93), 238(4.70).

HRMS: M^+ at m/z 446.175679; calcd. for $C_{20}H_{12}O_3TMS_2$, 446.173359 (+5.2 ppm error).

III. [3H]-anti-Diol Epoxide Synthesis

26. Phenyltrimethylammonium tribromide (PTT)¹⁰⁸

20 g of N,N-dimethylaniline plus 16 mL of dimethylsulfate was allowed to stand for 3 hours at 50°; the precipitated white crystals were filtered off, rinsed with benzene, and air-dried. This material was dissolved in 150 mL of 1:1 water-concentrated HBr, and then excess bromine (≈ 20 mL) was added with cooling. This mixture was stirred for two hours, triturated with methanol, and filtered. The product was recrystallized once from acetic acid and once from methanol. Yield was ≈ 6 g, mp 114.5-115.6° (lit. 115.5-116.5°).¹⁰⁸

27. Monobromo-trans-7,8-dibenzoyl-7,8,9,10-tetrahydrobenzo(a)pyrene (XXVI)¹⁰⁶

1.015 g (2.04 mmol) of dibenzoate XIX was dissolved in warm (50°) acetic acid-THF (60:40 v/v) [THF was prefiltered through Woelm grade 1 Alumina]. 2.0 g (5.32 mmol, 2.6 molar equivalents) of PTT in 3 mL of THF was added, and the mixture allowed to stir under nitrogen,

protected from light. After 4 hours an additional 2 g of PTT in 3 mL of THF was added. After 44 hours, saturated aqueous sodium bisulfite was added until the yellow color (bromine) disappeared. The solution was diluted with 500 mL of water, and the product filtered off, washed, and then dried in a vacuum oven at 50° for 4 hours. Yield was quantitative; light yellow crystals, mp 174-175°. NMR: (CDCl₃) 2.56(2H₉), 3.72(2H₁₀), 5.77(H₈), 7.0(H₇), 7.32-8.5(17 aromatic). MS: m/z 574, 576(1:1 ratio); also m/z 452,454; 330,332; 251(413), 122(97), 105(1000), 77(113). UV: 382(3.02), 354.5(4.69), 282.5(4.73), 250(4.63).

28. [³H]-trans-7,8-dibenzoyl-7,8,9,10-tetrahydrobenzo(a)pyrene
([³H]-XIX)

30 mg (52 μmol) of the monobromide XXVI was dissolved in 2 mL of dioxane plus 7.5 μL of triethylamine, and this solution placed in a 10 mL flask equipped with a magnetic spin-bar and catalyst tray (containing ca. 10 mg of palladium metal powder). This flask was connected to a vacuum line, completely enclosed within a negative-pressure glove box (Safety Services, Lawrence Berkeley Laboratory, Bldg. 75). The flask was evacuated, cooled to liquid nitrogen temperature, and the palladium dumped in. A uranium tritide (U³H₃) capsule was connected to the vacuum line and heated to 250° with an oven (this releases any ³He formed by β⁻ decay of the tritium). After 15 minutes the block was heated to 300°, and 52.5 Ci of ³H₂ (determined by the volume of the flask and pressure of the system) was admitted to the reaction vessel. The reaction mixture was warmed to room temperature and allowed to stir for 3.75 hours. System pressure was 730 mm. The crude reaction mixture was then transferred to a centrifuge tube and the palladium metal precipitated by centrifugation.

The solution (plus 1 mL of dioxane rinse from the palladium metal) was placed on the vacuum line and subjected to four freeze-thaw (liquid nitrogen) cycles to remove dissolved tritium gas. The solution at this point had a total activity of 3 Ci. All subsequent procedures were carried out in either a glove box or in a functioning hood, lined with adsorbent paper. Radioactivity was monitored by wipedowns and scintillation counting of the wiper.

216.8 mg of carrier trans-7,8-dibenzoyl-7,8,9,10-tetrahydrobenzo(a)pyrene (XIX) in 22 mL of dioxane was added to the above reaction mixture, and the product precipitated by adding 40 mL of water. The precipitated white crystals were filtered, washed with water, and redissolved in 50 mL of acetone. The volume of this solution was reduced at the boiling point by blowing a stream of nitrogen over the flask until crystallization began to occur. The solution was then cooled, the product filtered off, and the crystals washed with cold (-70°) acetone. Yield: 185.37 mg, 76% recovery. 480 μ g of this material was carefully weighed out on a Cahn Electrobalance, and dissolved in toluene to a final volume of 5.00 mL. Successive dilutions were then counted in Aquasol-2; the specific activity was determined to be 2.38 ± 0.1 Ci/ mmol. A sample of this material was spotted onto a thin layer chromatography plate (silica gel G) and developed in benzene-ethanol (19:1 v/v). The plate was scanned for fluorescence (exc. 248 nm, em. > 390 nm) on a Schoeffel Scanning Fluorometer (Schoeffel Instrument Co., Westwood, New Jersey); the plate was then cut into 1 cm sections and the sections counted in Aquasol-2 as gels. 99 ± 1 % of the radioactivity was observed to co-chromatograph with the fluorescent band of the authentic dibenzoate (XIX) carrier ($R_f = 0.7$).

29. [³H]-10-bromo-trans-7,8-dibenzoyl-7,8,9,10-tetrahydrobenzo(a)-pyrene ([³H]-XX)

The [³H]-dibenzoate was further diluted with carrier to a total of 355 mg (0.71 mmol). This material was suspended in 155 mL of CCl₄ and 133 mg (1.04 molar equivalents) of NBS added. The solution was placed in a jacketed photochemical reactor, purged with dry argon, and warmed to 50°. 2 mg of AIBN was added and the system illuminated with a 150 W sun lamp for 30 minutes. After 50 minutes the solution was cooled to 0°, filtered to remove succinimide, and the solvent removed on a rotary evaporator.

30. [³H]-trans-7,8-dibenzoyl-7,8-dihydrobenzo(a)pyrene ([³H]-XXI)

The crude 10-bromo derivative ([³H]-XX) was dissolved in 50 mL of xylene and heated to reflux under argon. After 12 minutes the solution was cooled and the xylene removed under vacuum. The product was recrystallized from acetone and air-dried.

31. [³H]-trans-7,8-dihydroxy-7,8-dihydrobenzo(a)pyrene ([³H]-XXII)

The dibenzoate ([³H]-XXI) was dissolved in 30 mL of THF, and 85 mg of sodium methoxide (ca. 2.5 molar equivalents) in 10 mL of methanol was added. The solution was stirred for 12 minutes at 65°, and then poured into 100 mL of ether plus 100 mL of water. The water wash was extracted with 50 mL of ether, and the combined ether phases washed three times with water, dried over potassium carbonate, and concentrated to ≈10 mL. The diol crystallized on standing as light yellow needles. These were filtered, washed with cold ether, and dried in vacuo. Yield: ca. 100 mg.

Specific activity was determined by weighing a sample (1800 μg) and counting various dilutions of a THF solution in Aquasol-2.

The specific activity was determined to be $1.30 \pm .05$ Ci/ mmol .

Radiochemical purity was determined by co-injecting a small aliquot together with carrier trans-7,8-dihydroxy-7,8-dihydrobenzo(a)pyrene onto a reverse phase HPLC system (2 Waters μ -Bondapak C_{18} columns connected in series, eluted with a gradient water-methanol solvent; column resolution was approximately 6000 theoretical plates). 1 mL fractions were collected and analyzed for radioactivity by scintillation counting in Aquasol-2. As shown in figure 9, 99 ± 1 % of the injected radioactivity co-eluted with the synthetic carrier diol; recovery of injected radioactivity was 100 ± 2 %.

1 mg of the labelled diol was stored at -70° in THF; when stored as a dry powder substantial decomposition was noted (ca. 2% per week at -70°).

32. $[^3\text{H}]$ -r-7,t-8-dihydroxy-t-9,10-oxy-7,8,9,10-tetrahydrobenzo(a)-pyrene ($[^3\text{H}]$ -XXIV)

99 mg of the $[^3\text{H}]$ -trans-7,8-diol in 30 mL of THF was mixed with 170 mg of 100% m-chloroperbenzoic acid and allowed to stir under nitrogen for 10 hours. The reaction mixture was diluted with ether (150 mL) and washed successively with 10% aqueous sodium sulfite, 8% aqueous sodium bicarbonate, and finally with water. The ether phase was dried over K_2CO_3 and reduced in volume. The diol epoxide crystallized on standing; the crystals were collected, washed with cold ether, and then dissolved in argon-purged THF containing 1% triethylamine. This stock solution was stored at -70° . Yield: 65.6 mg (63%).

Radiochemical purity was determined by hydrolyzing an aliquot in water, and co-injecting this material with authentic carrier hydrolyzed

diol epoxide onto a reverse phase HPLC system (2 Waters μ -Bondapak C_{18} columns connected in series, eluted with water-methanol). 1 mL fractions were collected and monitored for radioactivity by scintillation counting in Aquasol-2. The two tetrahydroxy-7,8,9,10-tetrahydrobenzo(a)pyrene hydrolysis products were monitored by fluorescence (exc. 248 nm, em. >370 nm). 97 ± 1 % of the radioactivity was observed to co-elute with the two tetraols. Radiochemical purity of the stock solution was routinely monitored with this procedure. Decomposition over a period of 8 months was observed to be less than 0.5% per month.

Chapter 4: DNA Binding Studies

The availability of the synthetic diol epoxides made it feasible to begin structural studies on the covalently bound benzo(a)pyrene-nucleic acid complexes formed in vivo or by in vitro (microsomal) assays. Since only picomole quantities of the enzyme-activated complex were available for study, the basic approach we undertook was to react synthetic diol epoxide with the nucleic acid and then compare the products of this reaction with the microsome-derived adducts. It was anticipated that a large number of products would be formed in such a reaction, in view of the inherent complexity of DNA as a target nucleophile. While increased amounts of adduct would be available for structural studies from this synthetic system, total quantities would still be minute by conventional standards (i.e., microgram range). The reasons for this are two-fold: 1) an effort was made to work within the same range of binding levels that are found in vivo (ca. 1 in 10^4 base pairs) in order to avoid structural artifacts encountered when working with highly modified DNA's; 2) we anticipated that the analytical techniques developed for this work could then be applied to analyzing material obtained directly from in vivo experiments. The first point had its origins in published reports on DNA alkylation by small alkylating agents--numerous investigators have reported that the type and number of products obtained from the reaction of DNA with methylating or ethylating agents can change dramatically as a function of solvent and concentration.^{109,110} When working with highly modified DNA's, one

runs the risk of studying products which bear little or no relationship to material formed under physiological conditions. A second consideration is that many DNA alkylation products are relatively labile structures; this can be a problem since the modified DNA must be degraded to small residues (oligonucleotides less than 5 residues in length) before a detailed structural analysis can be performed. There is no satisfactory method of non-enzymatically degrading DNA to monomeric units--- most methods rely on extremes of pH or heat to hydrolyze the polymer. For example, at low pH (<3) apurinic sites can be generated, and the resulting 2'-deoxyribonic acid cleaved with alkali via β -elimination (figure 1).¹¹¹ Acid or base-labile structures cannot survive such extreme reaction conditions. The implications of this are outlined in recent studies by Singer on the alkylation of RNA by ethylating agents¹¹² : as much as 80% of the products formed by the action of ethylnitrosourea on RNA are O-ethyl ethers, but their presence was not detected until a careful study was made using enzymatic, neutral pH methods of RNA hydrolysis. Previous to this study, use had been made of high pH to hydrolyze high molecular weight RNA, resulting in inadvertant destruction of the bulk of the alkylated RNA residues during the process of isolation.¹¹³ This problem was frequently encountered by RNA researchers because of the facility with which RNA can be degraded by alkali:

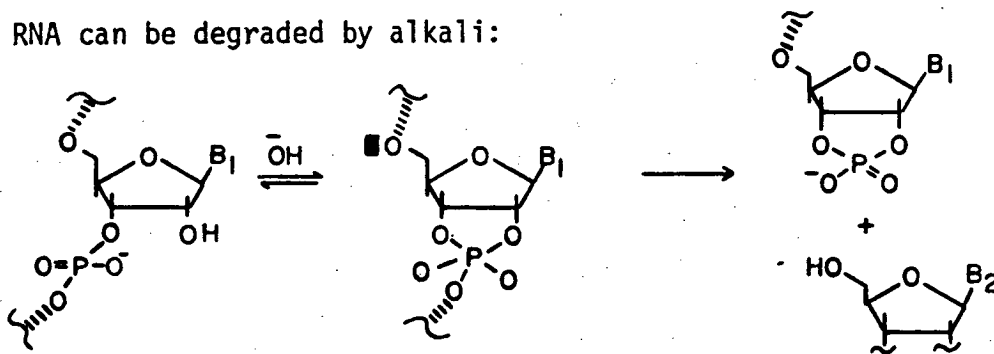

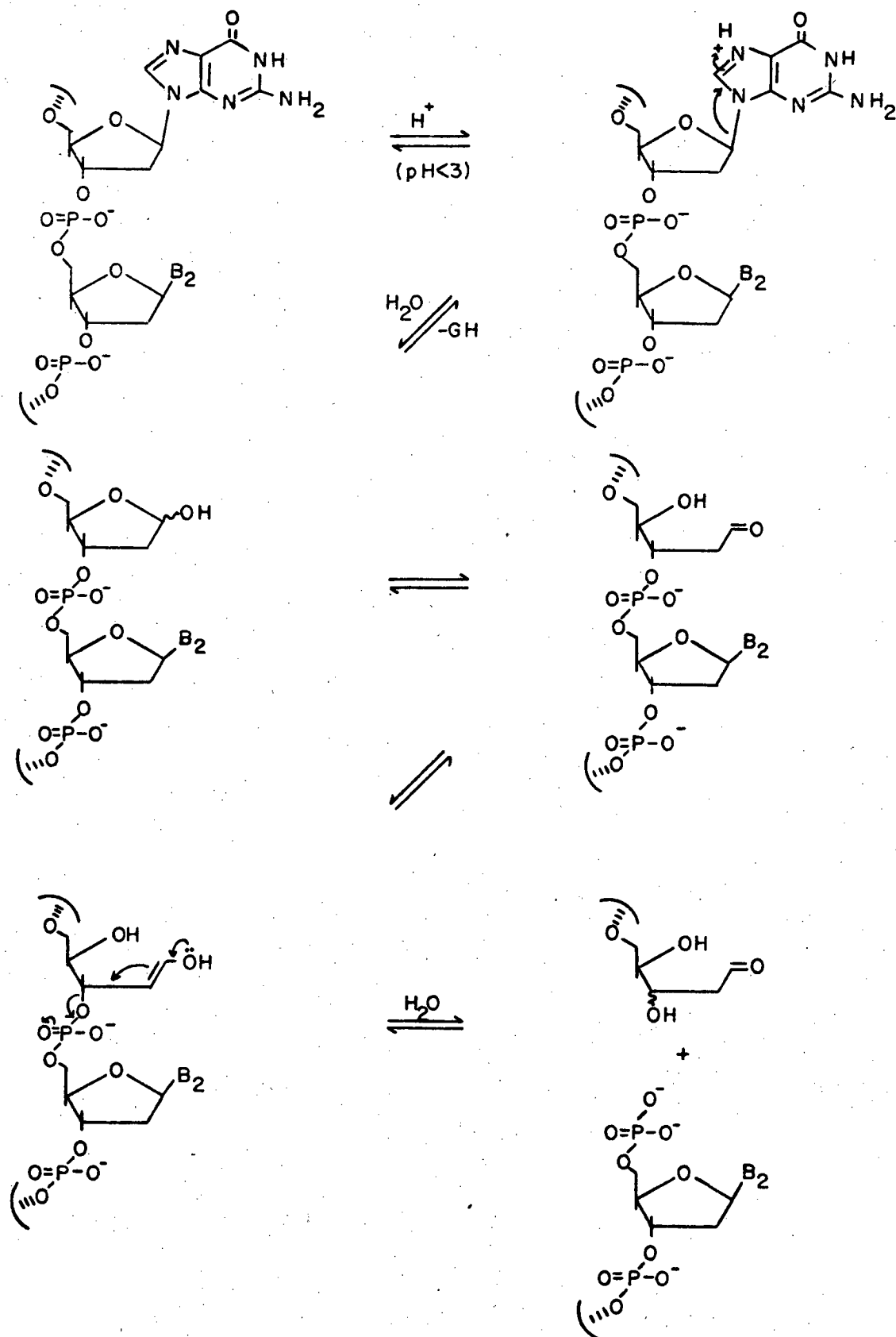

Figure 1: Polynucleotide strand scission via β elimination.

The use of alkaline hydrolysis avoids problems associated with the expensive and sometimes unpredictable enzymatic methods of hydrolysis. DNA, lacking a 2'-hydroxyl, cannot be efficiently hydrolyzed by alkali. We therefore determined that we would use neutral pH, enzymatic digestion for the recovery of modified monomers from alkylated DNA. Problems of scale are one consequence of this approach--- preparations involving much more than 50 mg of DNA become prohibitively expensive, as well as being difficult to work with (due to limitation on centrifuge availability, size of chromatography columns, etc.). Finally, as will become evident, the complexity of the product mixture that one obtains in these reactions could only be accommodated by the use of HPLC. Although extremely efficient and capable of high resolving power, HPLC at the time of this work was limited to sub-milligram quantities of material (particularly where maximum resolution is the goal). As a result of these various considerations, the structural elucidation of the diol epoxide-DNA adducts was necessarily based on microanalytical techniques--- primarily HPLC and high resolution mass spectrometry (HRMS). NMR, an extremely valuable tool for the structural analysis of stereoisomers, does not have the requisite sensitivity for working with sub-microgram quantities of material derived from biological sources. This is especially true for the large number of minor products formed in small molecule-DNA reactions.

Reaction of the syn and anti-diol epoxides with a variety of DNA's (calf thymus DNA was used for bulk preparations) was carried out in 0.01 M phosphate buffer at pH 7.5, using a ratio of diol epoxide to DNA of 12 nmol/ mg. Under these conditions the anti-diol epoxide has a half-life of approximately 2 minutes, while the syn isomer has

a half-life of ~ 30 seconds ("half-life" refers to hydrolysis in aqueous solution to tetrahydroxy-tetrahydrobenzo(a)pyrenes, with pseudo-first order kinetics).^{114,115} As described in chapter 3, the in vitro microsomal enzyme/ BaP binding assay results in a level of modification of DNA equal to one hydrocarbon adduct per 40,000 base pairs. Anti-diol epoxide used at this ratio (12 nmol/ mg of DNA) results in a modification level approximately five-fold higher (as determined by the amount of ³H-anti-diol epoxide that becomes covalently bound to the DNA). The syn isomer gives a similar level of binding, as determined by non-extractable fluorescence of the modified DNA, using the ³H-anti-diol epoxide-modified DNA as a standard. Thus the concentrations used in this study approximates those that could occur in vivo. Non-covalently bound hydrocarbon (primarily the hydrolysis product of diol epoxide, 7,8,9,10-tetrahydroxy-7,8,9,10-tetrahydrobenzo(a)pyrene) was removed by extraction with ethyl acetate, and the modified DNA further purified by ethanol precipitation. The DNA was then hydrolyzed enzymatically, using a mixture of endo- and exonucleases (DNaseII and spleen phosphodiesterase, resulting in nucleoside-3'-monophosphates), followed by treatment with alkaline phosphatase to remove the 3'-phosphate. This mixture of nucleases, nucleosides, and modified nucleosides was then chromatographed on Sephadex LH20 (a lipophilic, macroporous gel based on dextran), utilizing a combination of molecular sieving and adsorption chromatography. The enzymes and unmodified nucleosides were eluted with buffer, and ³H-containing material was removed by eluting the column with a buffer-methanol gradient. The ³H-containing material could then be analyzed by HPLC. Recovery studies demonstrated that >97% of the ³H activity could be

recovered from the modified DNA as a methanol-soluble fraction from the LH20 column. Enzymatic hydrolysis was thus capable of degrading the modified polymer to small units.

Figures 2a and 2b show HPLC fluorescence elution profiles of the modified nucleosides obtained by reacting DNA with (+)anti- and (+)syn-diol epoxides, respectively. The fluorescence detection system (Schoeffel FS970; Schoeffel Instruments, Westwood, New Jersey) used here allowed detection of as little as 50 picograms of material containing a tetrahydro-benzo(a)pyrene chromophore. Fluorescence sensitivity was thus comparable to that of ^3H detection via scintillation counting at the specific activities used in this study (0.1- 5.0 Ci/mmol). Figure 3a represents the fluorescence trace and ^3H profile obtained from DNA modified by microsomal enzyme activated [$\text{G-}^3\text{H}$]benzo(a)pyrene. The similarity between this elution profile and that of the (+)anti-diol epoxide-DNA adducts is apparent, and figure 3b shows the results of co-injecting the enzyme-activated [$\text{G-}^3\text{H}$]BaP-DNA and synthetic (+)anti-diol epoxide-DNA adducts. The major fluorescent peak of the (+)anti-diol epoxide-DNA product co-chromatographs with the major enzyme-activated [$\text{G-}^3\text{H}$]BaP-DNA adduct. The elution profile of the adducts obtained from the syn-diol epoxide is markedly different from that of the enzyme-activated BaP-DNA and anti-diol epoxide-DNA products. Thus the major products obtained with the enzyme system appear to be derived from the anti-diol epoxide, although some of the minor products do co-elute in the same region as the syn-diol epoxide-DNA adducts. Thus, chromatography of the microsome-catalyzed adducts alone results in fluorescence detection of peaks corresponding to 1, 4,5, and 7 of the synthetic (+)anti-diol epoxide adducts; peaks 2,3,

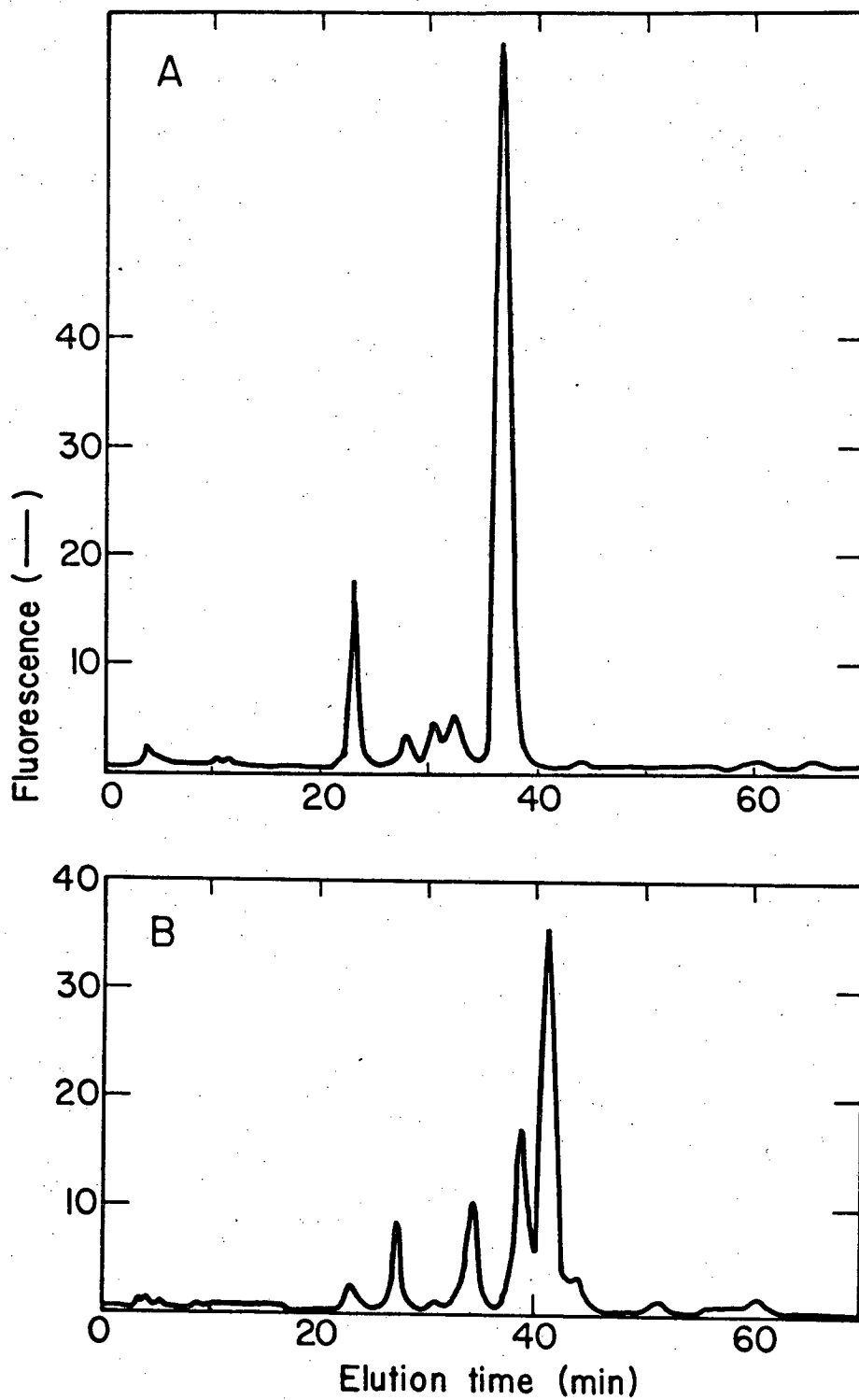
**Figure 2**

XBL 775-4378

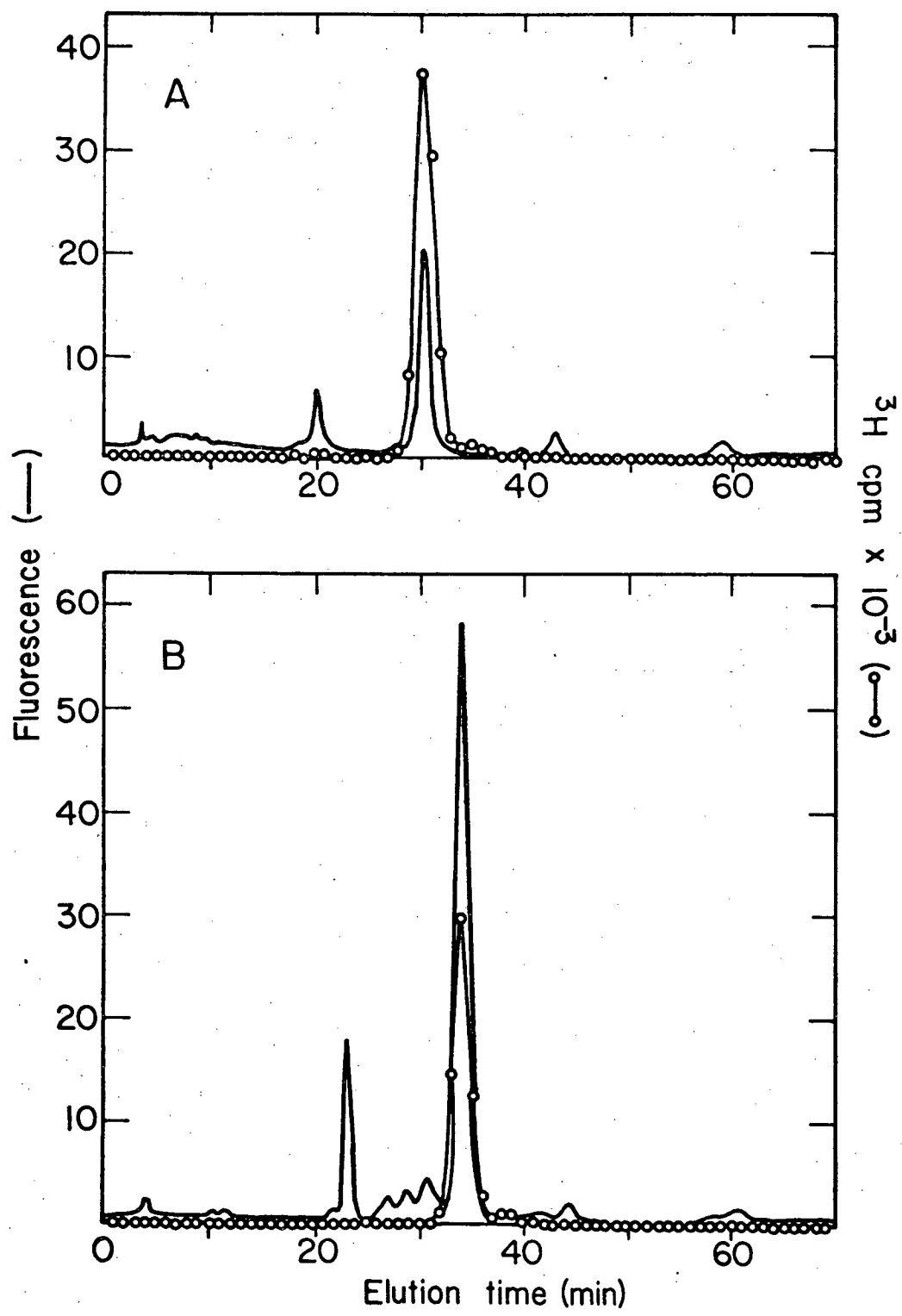

Figure 3

XBL 775-4379

and 6 are not observed (either by fluorescence or by radioactivity; the peak eluting at 42 minutes in figure 3a does not co-elute with peak 6 in figure 2a). Therefore the reaction between (+)anti-diol epoxide and DNA yields at least three more adducts (peaks 2,3, and 6) than does microsomally-activated BaP plus DNA. The peak at ~42 minutes in figure 3a does co-elute with the main component from the reaction of (+)syn-diol epoxide and DNA, and could indicate that a small amount of the syn isomer is formed during enzyme-mediated oxidation of benzo(a)pyrene.¹²⁹ The major products appear to involve the anti isomer, however.

Our initial studies to determine the structures of these various adducts (each available in microgram amounts) were directed towards identifying the nucleic acid bases (guanine, adenine, cytosine, thymine) present in each peak of figure 2a. We approached this problem via a double-labelling scheme, where ^3H or ^{14}C (available from the National Cancer Institute, Bethesda, Maryland) labelled (+)anti-diol epoxide would be reacted with DNA containing one of the four bases (A,G,C, or T) labelled with ^3H or ^{14}C . Each chromatographic peak could then be analyzed for the presence of ^3H and ^{14}C : for example, ^3H would confirm the presence of the diol epoxide moiety in each peak, and ^{14}C would confirm the presence of guanine in a given peak for the adducts derived from the reaction of [^3H]-(+)anti-diol epoxide with [8- ^{14}C]guanine-containing DNA. This study, then, required four samples of DNA, each labelled unambiguously with a different radioactive purine or pyrimidine base. These four DNA samples were prepared by incorporating three unlabelled nucleoside triphosphates and one ^3H -

labelled nucleoside triphosphate into high molecular weight ($>10^5$ daltons) DNA by *E. coli* DNA Polymerase I (EC 2.7.7.7, "Kornberg polymerase"), using calf thymus DNA as the template ($>10^7$ MW).¹¹⁶ The labelled DNA was ethanol-precipitated, dialysed to remove low molecular weight impurities, and then reacted with ^{14}C -labelled (+) anti-diol epoxide. Covalent adducts were isolated after enzymatic hydrolysis and analyzed by HPLC. The results of three of the four double label experiments are presented in figures 4b, 4c, and 4d. Figure 4b represents the products of the reaction of ^{14}C -(+)anti-diol epoxide with ^3H -deoxyguanosine-labelled DNA. Peaks 3 and 5 contain both ^3H and ^{14}C , and therefore represent hydrocarbon-deoxyguanosine adducts. From the specific activities of the diol epoxide and base a 1:1 ratio of the two components was calculated (see Table 1, below). Similar inspection of figures 4c and 4d identifies peaks 6 and 7 as deoxyadenosine adducts, and peak 4 as possibly a deoxycytidine adduct. Assignment of the identity of peak 4 was only tentative, because of the lack of complete symmetry and coincidence of the ^3H and ^{14}C . Deoxythymidine adducts were not observed, despite our ability to detect approximately one adduct per 2.5×10^7 base pairs (determined by the maximum specific activity of the ^3H -thymidine-5'-triphosphate available to us, 15- 30 Ci/ mmol). The relative percentage of each adduct formed is shown in Table 1. Binding occurred to the extent of 92% deoxyguanosine, 5% deoxyadenosine, 3% deoxycytidine, and 0% thymidine. Peak 1 derived from all four reactions contained only ^{14}C . The presence of ^{14}C or ^3H in peak 2 could not be reliably ascertained at the specific activities used in these experiments.

HPLC Coval. Adductsa) DEP - DNA + Micros [³H] BaP - DNAb) [¹⁴C] DEP - [³HdG] DNA

Figure 4

XBL 775-4409

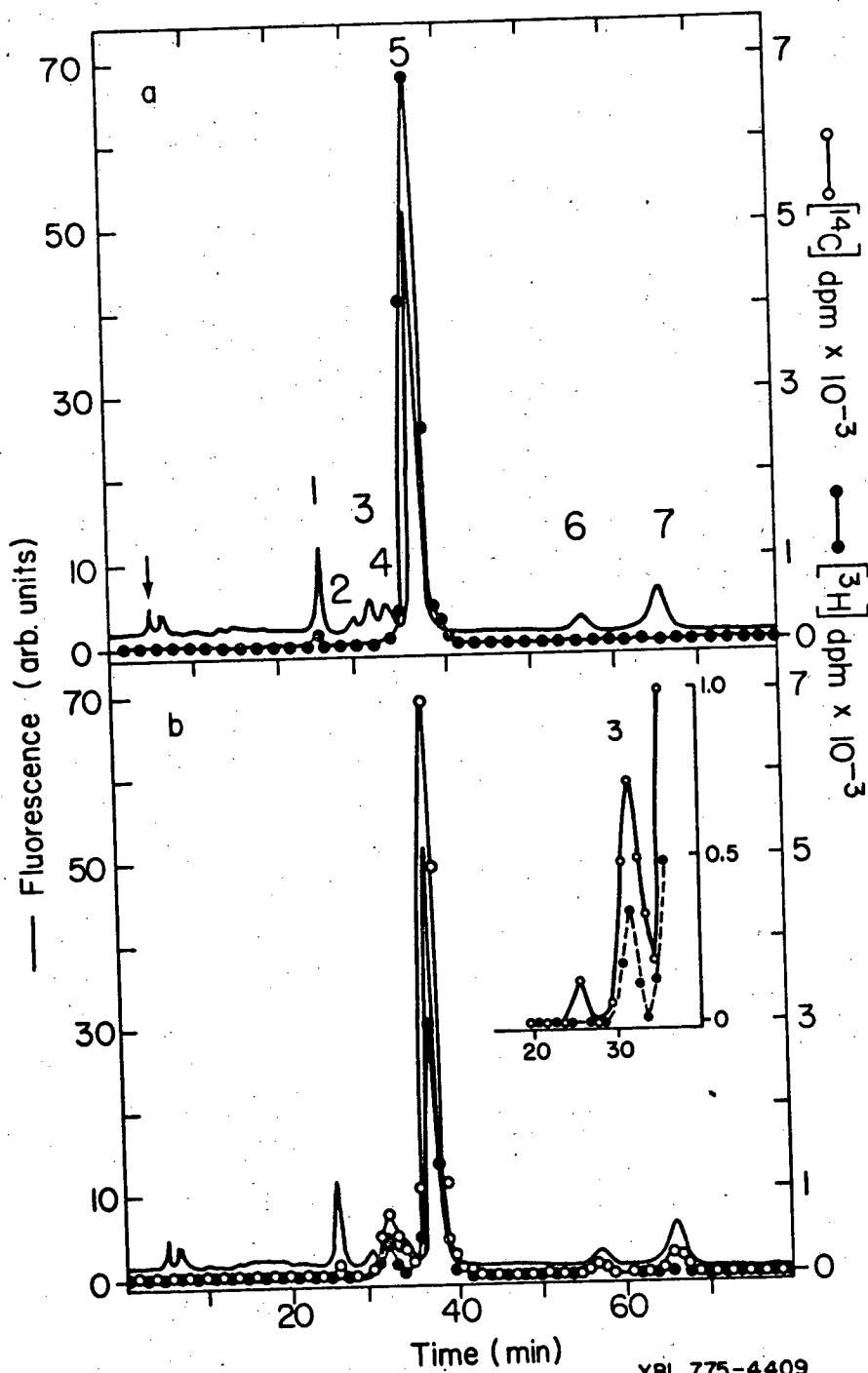
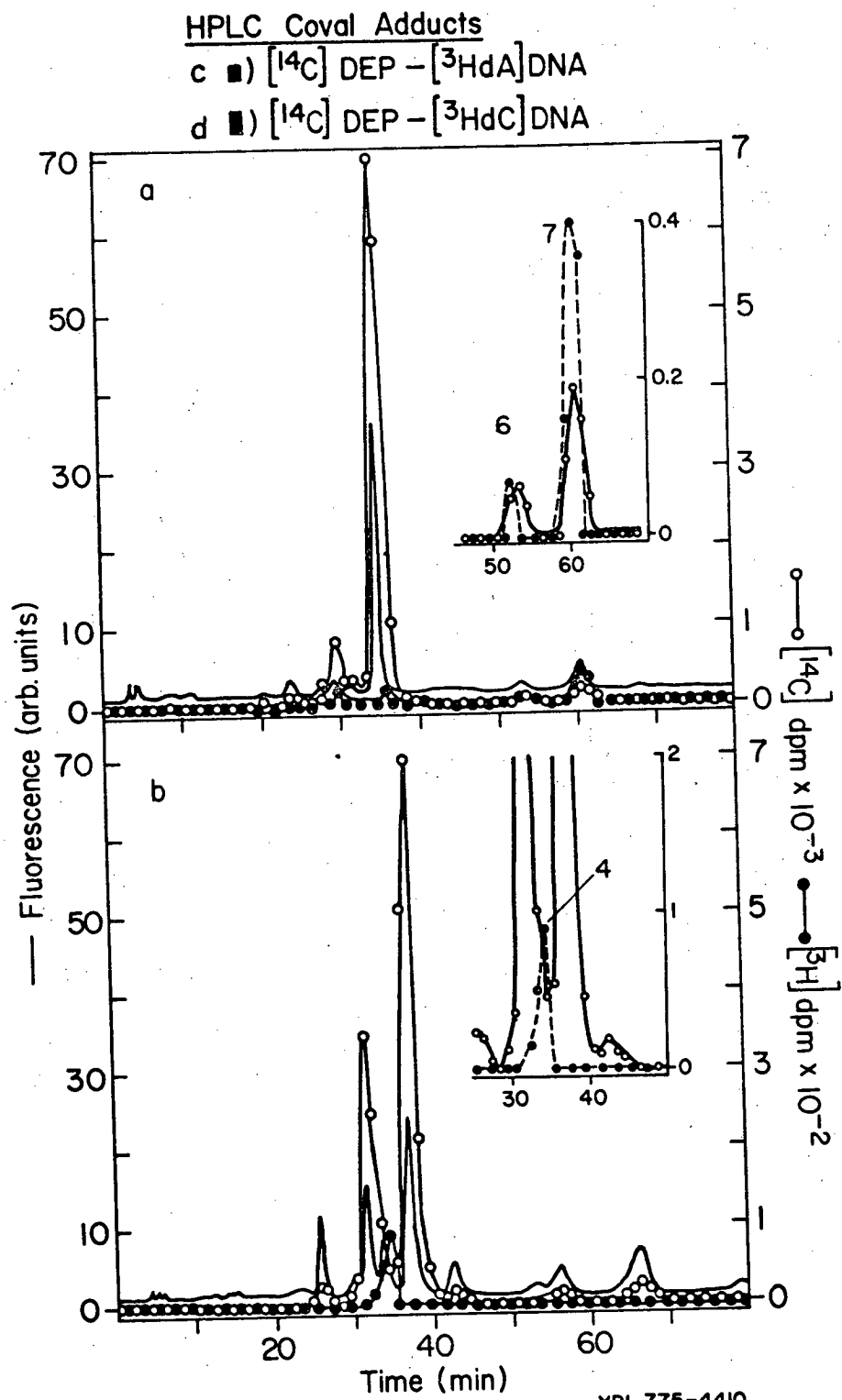

Figure 4

Table 1
Relative Distribution of (+) anti-BaP Diol Epoxide Adducts
With the Bases of DNA

Peak No.*	1 [†]	2	3	4	5	6	7
Base	-	?	dG ₁	dC ₁ [‡]	dG ₂	dA ₁	dA ₂
Percent							
Total Based on §							
³ H	-	-	10	2.4	86	0.1	1.4
¹⁴ C	-	-	10	3	82	1	4

*Peak numbers refer to Figure 4a.

[†]Peak 1 is probably a hydrolysis product of the diol epoxide, 7,8,9,10-tetrahydroxy-7,8,9,10-tetrahydrobenzo(a)pyrene

[‡]Assignment of this adduct is tentative.

[§]Computed from Figure 4b.

High Resolution Mass Spectrometry. A detailed structural analysis of the contents of peaks 1 - 7 was complicated by the quantities of material that were available for study. Preparative-scale (50-100 mg DNA) reactions allowed isolation of tens of micrograms of peak 5, but only a few micrograms of each of the other components could be obtained. The only analytical technique with the requisite sensitivity available to us at this time was mass spectrometry. A conventional low resolution ($m/\Delta m \leq 1000$) mass spectrum of an unknown should give 1) the molecular weight of the compound; and 2) a fragmentation pattern of the compound, which (at least in theory) can be used to determine what the

overall molecular structure was like. With true unknowns, however, a considerable amount of guesswork must enter into any interpretation of a mass spectrum. When considering the problems and limitations of this technique, it is instructive to refer to the design of a conventional mass spectrometer. Figure 5 is a schematic diagram of a double-focusing mass spectrometer using a modified Nier-Johnson geometry.¹¹⁷

The four components of the spectrometer include the ion source, I; the electric sector, E; the magnetic sector, B; and the ion multiplier (detector), M. The sample is first vaporized by heating under high vacuum ($\sim 10^{-7}$ torr). The gas phase sample molecules are then bombarded with energetic electrons (typically 70 eV) to form gas phase ions. The primary products of this event are sample molecules that have lost an electron (radical cations):

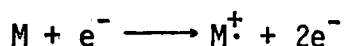

The species $M^{\cdot+}$ (molecular ion) is generally formed with a high internal energy as a result of these inelastic collisions, and can fragment in characteristic ways to produce a series of daughter ions:

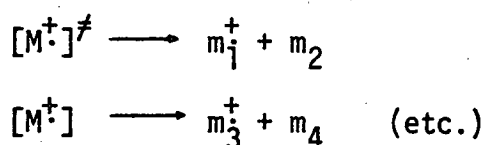

These ions are then accelerated by a large potential difference (typically 2-10 kV) and focused into a defined ion beam. Neglecting the electric sector for the moment, an ion of mass m_1 will be transmitted through the magnetic sector B (and therefore detected by the ion multiplier M) according to the relationship

$$\frac{m_1 v_1^2}{r} = v_1 e B_1$$

where v_1 is the velocity of m , r is the radius of the magnetic sector,

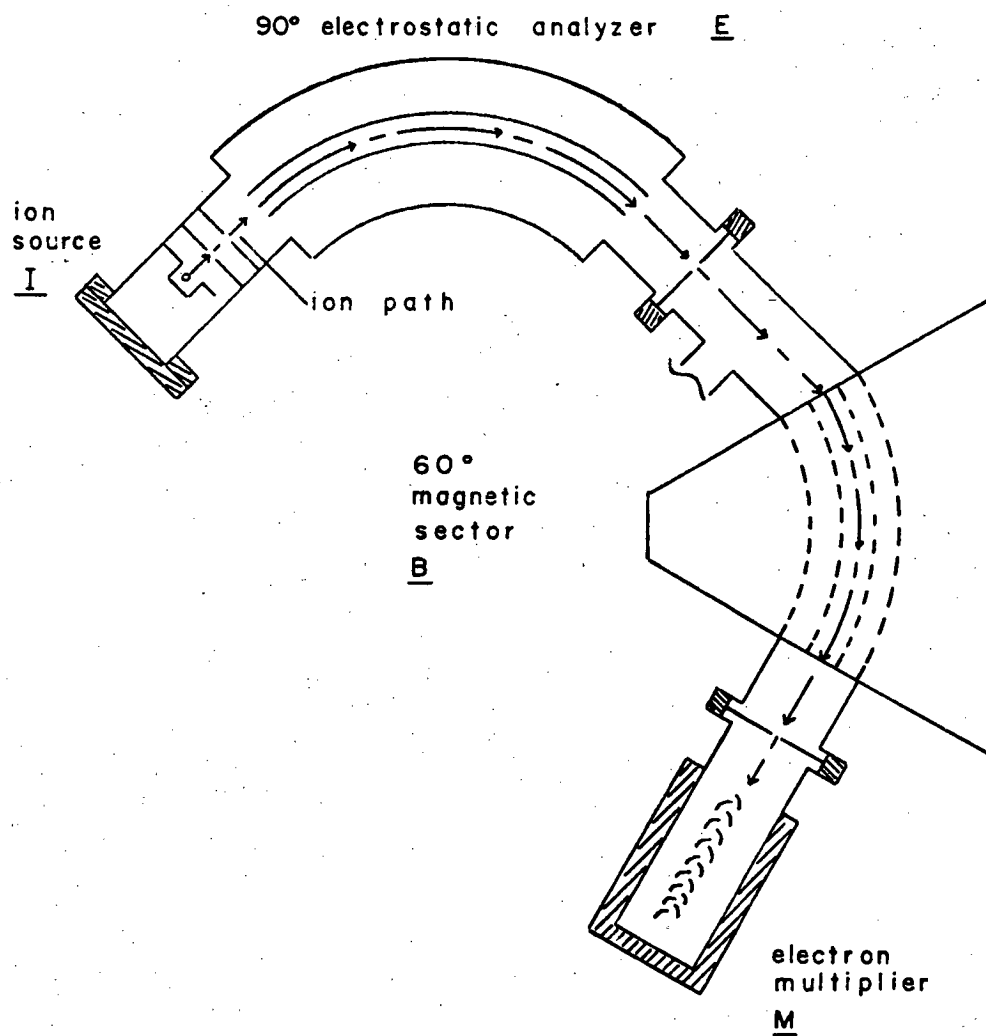

Figure 5: Schematic of Nier's double-focusing mass spectrometer¹¹⁷

e is the electric charge, and B is the magnetic field strength. An ion of mass m_1 and charge e accelerated through a potential V will have a kinetic energy eV :

$$1/2 m_1 v_1^2 = eV$$

Rearranging and substituting for v_1 gives

$$m/e = r^2 B^2 / V.$$

Thus at a constant accelerating voltage V , ions of different mass to charge ratio m/e will be transmitted through the magnetic sector B (and therefore detected) by sweeping the magnetic field strength. In practice, the initially formed ions m_1 , m_2 , etc. will have an energy "spread" due to initial kinetic or thermal energy prior to acceleration, with consequent effects on the measurement of m/e . This problem is eliminated by the electric sector E in Figure 5; an ion beam of narrow energy spread will be transmitted according to the relationship

$$\frac{m_1 v_1^2}{R} = eE_0$$

where R is the radius of the electric sector and E_0 is the electric field strength. This combination of both velocity and direction focusing allows measurement of mass to charge ratios at a resolution of as much as one part in 10^5 . Since the monoisotopic atomic weights of the nuclides are not exact whole numbers on the basis of mass (using as reference $^{12}\text{C} = 12.000000$ amu), measurement of the mass of an ion with sufficient accuracy allows unequivocal assignment of its elemental composition. In practice, a resolution of $M/\Delta M \geq 10,000$ is sufficient to assign elemental compositions to the ion, especially when isotope peaks are simultaneously monitored for verification of the assigned composition.

Problems often encountered in conventional electron-impact low resolution mass spectrometry include 1) identifying the molecular ion, and 2) determining whether or not some mass peaks are due to artifacts such as pyrolysis reactions (induced by excessive heating of the sample), impurities in the sample, etc. Many complex structures do not present a molecular ion, since sufficient energy is imparted to the molecule either by heating or by electron bombardment to cause extensive fragmentation to take place. Artifact signals in a low resolution mass spectrum are difficult (if not impossible) to distinguish from "real" signals. When dealing with an unknown of complex structure, one must first analyze a series of standard compounds that have structural features similar to that of the unknown; this will greatly increase one's confidence in the validity of any data obtained on the unknown. In the case of the diol epoxide-DNA adducts, a standard series of compounds included the four nucleosides deoxyguanosine, deoxyadenosine, thymidine, and deoxycytidine, as well as the large number of benzo(a)pyrene derivatives described in chapter 3. In order to avoid potential ambiguities in analyzing fragmentation patterns (sample impurities, etc.), we decided to rely on high resolution data for all structural assignments. The unique mass spectrometry system available to us made a thorough structural study possible on quantities of sample ranging from 0.1 to 3.0 micrograms. The "LOGOS II" data system is unique in that high resolution measurements are simultaneously carried out on all sample peaks present in the mass spectrum; total sample requirements are under 1 μg .¹¹⁸ This system is based on a Kratos/AEI MS 902 mass spectrometer (operating at $M/\Delta M \geq 10,000$), interfaced to a Xerox/Sigma 7 computer.¹¹⁹ An internal standard (perfluorinated kerosene, or PFK)

is present at all times, allowing a calibration curve at high resolution to be constructed. Sample peaks are then differentiated from either PFK or background signals, assigned an accurate mass (and intensity) value based on the internally generated calibration curve, and the data is then transferred to either disc or tape for storage. The instrument scans the desired mass range repetitively (typically 1000-70 amu), so that the sample can be introduced by slow heating, and the total ion current monitored to determine at which point the sample has been introduced. This also provides some confidence that a single component is being analyzed, since one can effectively fractionally "distill" separate components of a mixture into the ion source by careful control of the sample heating rate. More than 2000 resolved sample peaks can be generated by a complex structure undergoing fragmentation at 70 eV; the LOGOS-II system allows accurate mass measurement to be carried out on all such peaks that are present above a pre-set threshold.

Derivatization Methods. Nucleosides have structures that are highly polar, as well as being thermally labile. Attempts at obtaining conventional electron-impact mass spectra on free nucleosides have been largely unsuccessful. For the most part, one obtains pyrolysis fragments, many of which bear only an indirect and complicated relationship to the original structure. Accordingly, researchers have developed a variety of chemical derivatization techniques to overcome the problems associated with heating highly polar molecules in order to volatilize them prior to ionization.¹²⁰ These techniques are generally aimed towards increasing the vapor pressure of a compound by decreasing the polarity of ionic groups present in the original structure. For

example, converting carboxylic acids to methyl esters or amines to N-acyl derivatives decreases the extent of ionic interactions and hydrogen-bonding in the solid (crystal) state, thus increasing the vapor pressure of the compound. One can then obtain gas phase sample molecules at lower temperatures, eliminating problems caused by thermal decomposition that takes place at high temperatures. However, chemical derivatization can introduce additional complexities into structural analysis. Certain derivatives (for example, trimethylsilyl groups) have a relatively high molecular weight and, for a polyfunctional compound such as a nucleoside, can easily double or triple the molecular weight. This decreases the absolute accuracy with which its accurate mass can be measured; the addition of many different heteroatoms can also complicate the unambiguous assignment of an elemental composition to the mass. For example, an ion of structure "b" whose mass has been measured at $M/\Delta M$ 10,000 will have seven possible compositions where R = methyl, 9 for R = SiMe₃, and 15 for R = $\begin{matrix} \text{O} \\ \parallel \\ \text{CCF}_3 \end{matrix}$ (compositional tolerance of 10 ppm, where error in ppm = (measured mass - exact mass) $\times 10^6$ / measured mass).¹²¹

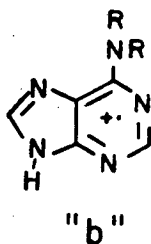

A second concern when using chemical derivatization is the problem encountered in trying to modify a complex structure that may be labile under the derivatization condition. For example, diazomethane/ether is a suitable reagent for methylating simple sugars prior to mass

spectrometry, but purine nucleosides would be destroyed under such conditions (via N-methylation and subsequent depurination). It must also be realized that derivatization is a chemical reaction; some procedures may not be practical to carry out on extremely small amounts of material, or may involve complicated purification procedures after derivatization. Finally, some types of derivatives can drastically alter the amount of information present in a fragmentation pattern. Introduction of a trimethylsilyl group, for example, often results in a spectrum with intense signals for peaks involving the TMS group (m/z 73, 75), but extremely weak signals for peaks involving the carbon skeleton of the molecule in question. In general, the choice of derivatives for mass spectrometry is complicated, and will depend on the structure in question, the quantity of material available for analysis, and the type of information one is trying to obtain. The best procedure in many cases is to prepare several types of derivatives and compare results. For example, procedures exist where a free amino group ($-NH_2$) can be dimethylated, monosilylated,¹²³ or acylated.¹²⁴ Reaction conditions and reagents can be used where derivatization of the amine can take place with or without simultaneous derivatization of a hydroxyl group.¹²⁴ In addition, isotopically labelled derivatizing groups can be used (eg. $-CD_3$, $-Si(CD_3)_3$, $-C(=O)CD_3$) and the mass shift from the unlabelled derivative used to determine the number of derivatizing groups on the structure in question.

Three different derivatives have gained acceptance for modifying nucleosides to allow direct probe mass spectrometry: methylation, trimethylsilylation, and acetylation.¹²⁵ McCloskey and coworkers have published extensive studies on the fragmentation patterns of nucleosides

modified by all three types of derivatives.^{121,126,127} The suitability of each procedure for modifying diol epoxide-nucleoside adducts was determined by first working with 7,8,9,10-tetrahydroxy-7,8,9,10-tetrahydrobenzo(a)pyrene and the unmodified nucleoside separately.

The methylation procedures used in this work were first developed by Hakamori.¹²² The basic procedure is to first treat the compound with a solution of dimethylsulfoxide anion in DMSO (generated by reacting DMSO with sodium hydride), followed by methyl iodide. The strongly basic methyl sulfinyl carbonion (pK_a 23-27) removes exchangeable hydrogens; methyl iodide then alkylates each anionic site. The methyl sulfinyl carbonion is also a poor nucleophile, thus minimizing side reactions. McCloskey and coworkers applied this technique with success to a series of ribo- and deoxyribo-nucleosides.¹²¹ We achieved identical results to those reported by McCloskey with this technique; in addition, the sole product recovered from the methylation of 7,8,9,10-tetrahydroxy-7,8,9,10-tetrahydrobenzo(a)pyrene was the permethyl derivative (m/z 376). Methylation with CD_3I gave products with molecular ions shifted the appropriate number of mass units higher (Figure 6). A detailed analysis of the fragmentation patterns of the methylated nucleosides was conducted by McCloskey, who showed that several fragmentation pathways are operative. These are (see Figure 7): 1) scission of the glycosidic C-N bond to generate either a "base + H ion" or a sugar ion ("S"); 2) simple loss of methyl, methylmethoxy, or methanol from M^+ (ions "a'", "g", or "e", respectively); 3) ions due to further fragmentation of the "base + H" species (i.e., loss of $CH_2=NH$); 4) ions due to further fragmentation of the sugar moiety (m/z 85, and ions "t" and "S-H"); and 5) ions composed of the intact base with a fragment of

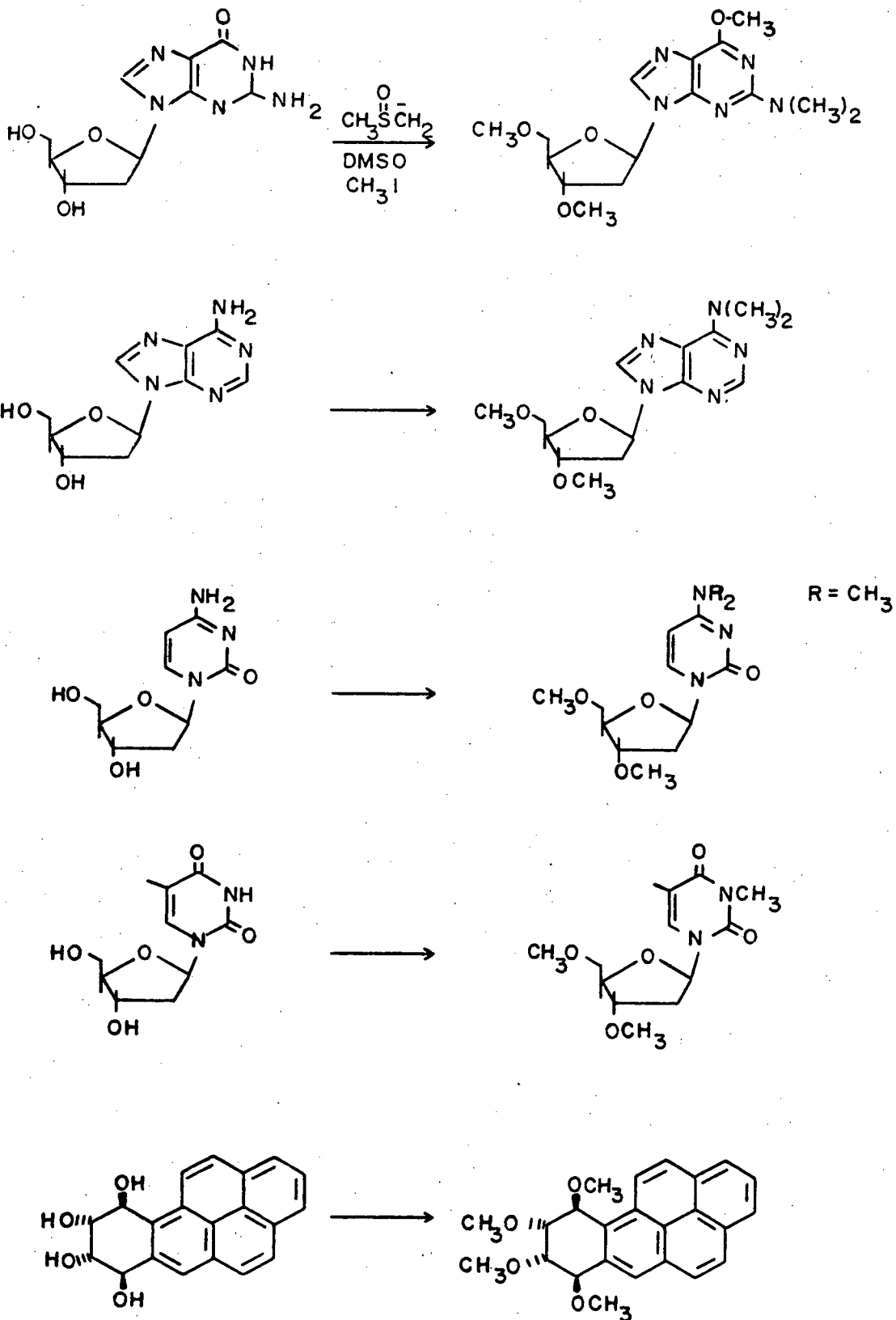

Figure 6 Permethyated nucleoside structures ^{121, 128}

the sugar attached (ions "j" and "k"). Figure 7 illustrates these various fragmentation pathways for deoxyadenosine; similar results (relative intensities vary considerably) were obtained for the other nucleosides. The success of this procedure with the tetraol of benzo(a)pyrene suggested that it would be generally useful for working with the diol-epoxide-DNA adducts. Despite the strongly basic conditions, no products exhibiting a chromophore different from that of 7,8,9,10-tetrahydrobenzo(a)pyrene (indicating dehydration) were found by fluorescence or UV-absorbance.

Since the nucleoside-diol epoxide adducts were labelled with ^3H , yields from the methylation reactions could be estimated by determining the amount of chloroform-soluble ^3H -containing material generated by the reaction. It was observed that when working with very small quantities of material (< 10 μg), yields fell dramatically (to less than 10%). This problem was eventually traced to two sources. One problem was the behavior of the diol-epoxide DNA adducts on glass surfaces--when deposited on a glass surface by evaporation of solvent, the material would redissolve in fresh solvent only very slowly. Sonication or vortexing was found to be essential in order to redissolve the material. A more serious problem was encountered in analyzing the products of nucleoside methylation by HPLC--more than one product was observed in some instances, and the complexity of the product mixture varied with the total reaction time. Other researchers have observed the same effects; what is apparently occurring is that with very long reaction times (5 - 90 min.), heterocycles become "over-methylated," leading to quaternary nitrogen-methyl derivatives. These derivatives are then water-soluble due to the charge on the nitrogen, and generate complex

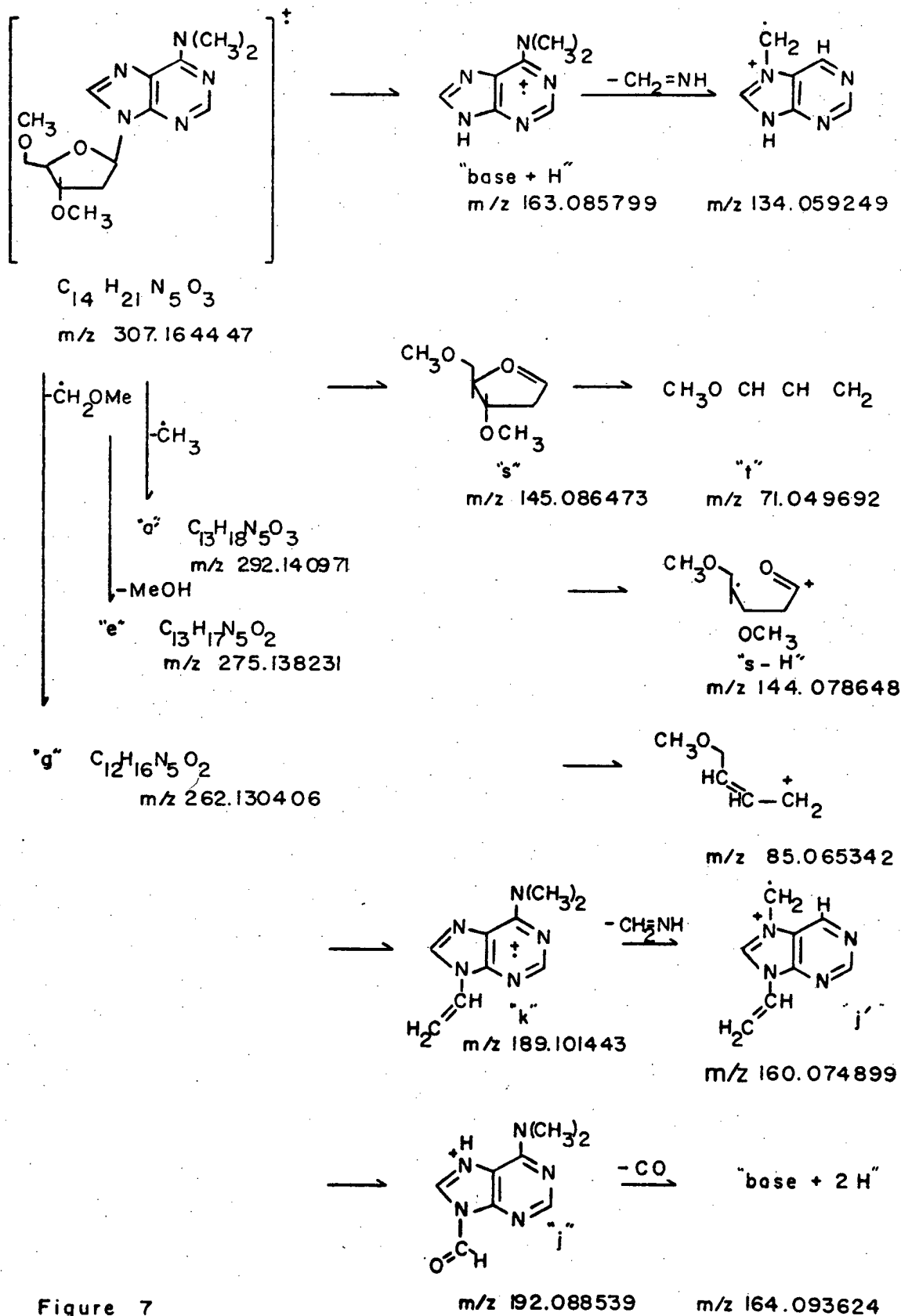

Figure 7

mass spectrometric fragmentation patterns since they undergo pyrolysis at high temperatures. This problem has been noted by Morris for peptide methylations; the key to avoiding it is to use short reaction times (~ 90 sec).¹²⁸ With the methylation procedure described in the "experimental" section, only single products (by HPLC) were obtained for the unknown P1 through P7.

Although the majority of the mass spectrometric analyses of P1-P7 were performed on either methylated or deuterio-methylated material, other derivatives were prepared for confirmation of some structures. Acetylated material was found to be of little use, as extensive fragmentation occurred in all acetylated materials. In some cases over 90% of the total ion current in a spectrum was due to mass 43 (CH_3CO). Trimethylsilyl derivatives were found to be useful in confirming the identities of some structures, despite the high mass (72 mass units added per TMS group) of the resulting derivative. A large number of silylating reagents and conditions were tried without success--either complex product mixtures or extremely low yields made use of each method impractical. A high-temperature (100°) method originally developed for steroids with sterically hindered hydroxyls was finally adapted for use with the diol-epoxide-DNA adducts. This procedure uses the highly reactive silylating reagent N-trimethylsilylimidazole (TSIM). As was observed by other researchers, poly-TMS derivatives (especially those containing -NH-TMS functionalities) are labile species, undergoing facile hydrolysis on standing for more than a few hours.¹²⁶

Diol Epoxide-DNA Structure Analysis. The structures of the anti-diol epoxide-DNA adducts P1-P7 were determined by a high resolution mass spectrometry study of their methyl or trimethylsilyl derivatives.

Verification of elemental compositions, when in question, was obtained by perdeuteromethylation and comparison of the data with results obtained for the methylated compound.

P1 had a retention time on HPLC identical to that of the hydrolysis product of the diol epoxide, 7,8,9,10-tetrahydroxy-7,8,9,10-tetrahydrobenzo(a)pyrene. High resolution mass spectrometry of the permethyl and per-deuteromethyl derivatives of P1 gave molecular ions at m/z 376.169189 ($C_{24}H_{24}O_4$, -4.59 ppm) and m/z 388.242305 ($C_{24}H_{12}D_{12}O_4$, -1.25 ppm), respectively. The fragmentation patterns and elemental compositions of all peaks in each case was identical to that of authentic permethylated tetraol, obtained by hydrolyzing anti-diol epoxide in water. Both Yang *et al.*¹⁰⁴ and Jerina¹⁰¹ have shown that hydrolysis of anti-diol epoxide in water gives two isomers, corresponding to cis and trans addition of water at C-10 of the diol epoxide. The presence of tetraols in the diol epoxide-DNA adduct mixture was not entirely unexpected; presumably some material is carried through the isolation procedure used for the diol epoxide modified DNA. The tetraols may also be formed by hydrolysis of unstable DNA-diol epoxide adducts.¹²⁹

Figure 8 shows composite nominal mass plots for the high resolution mass spectra of the permethyl derivatives of P2, P5, and P7. It was observed that the mass spectrum of permethyl-P6 was identical to that of permethyl-P7. Permethyl-P3 was identical to that of permethyl-P5, and permethyl-P4 was similar to permethyl P2 (P4 appeared to be a mixture of two species--one with a mass spectrum identical to permethyl P2, and a relatively volatile material identical to 7,8,9,10-tetrahydroxy-7,8,9,10-tetrahydrobenzo(a)pyrene). In order to simplify the structural analyses of P2, P5, and P7 (and therefore P3, P4, and P6),

HIGH RESOLUTION MASS SPECTRUM OF P-2 CH₃

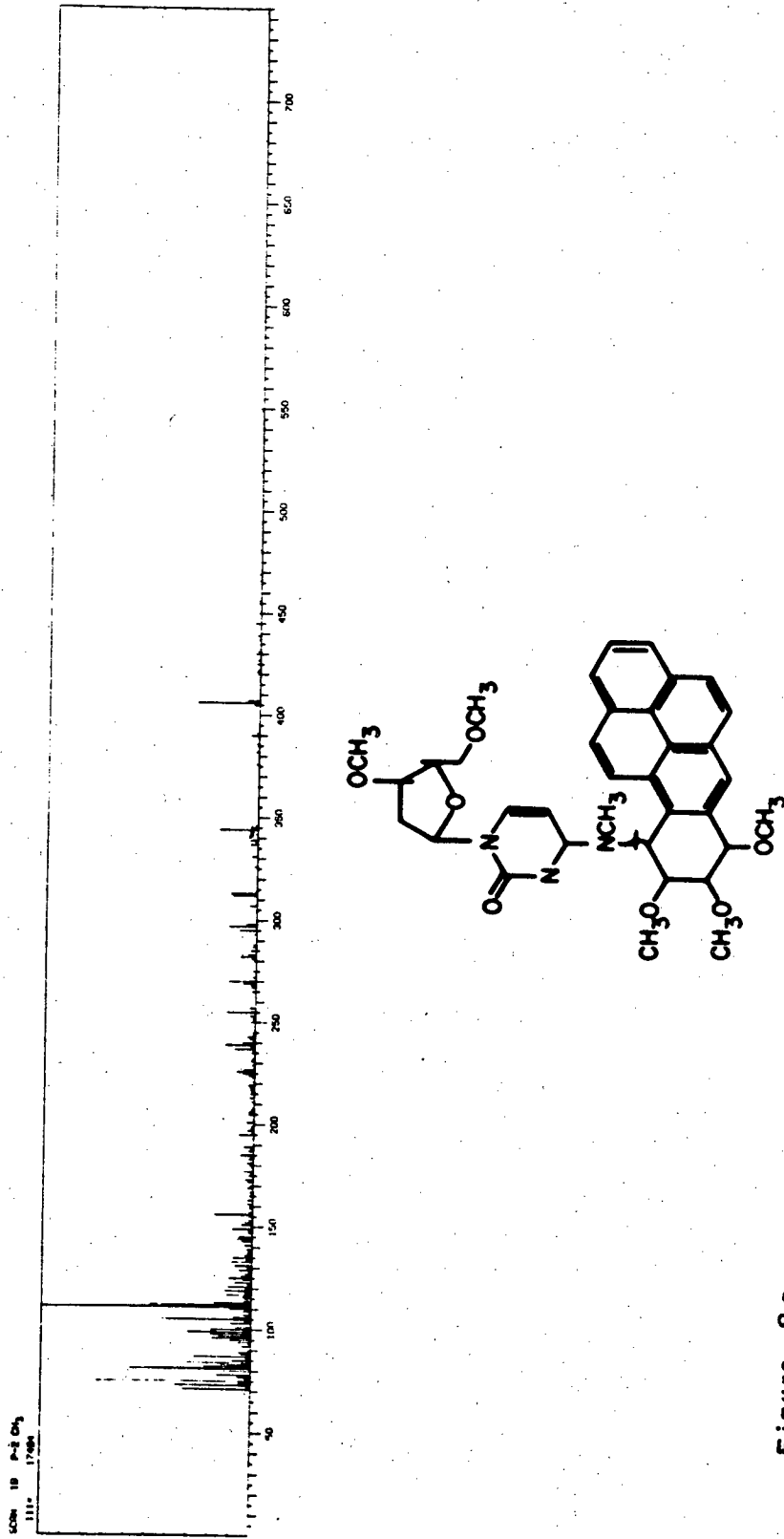
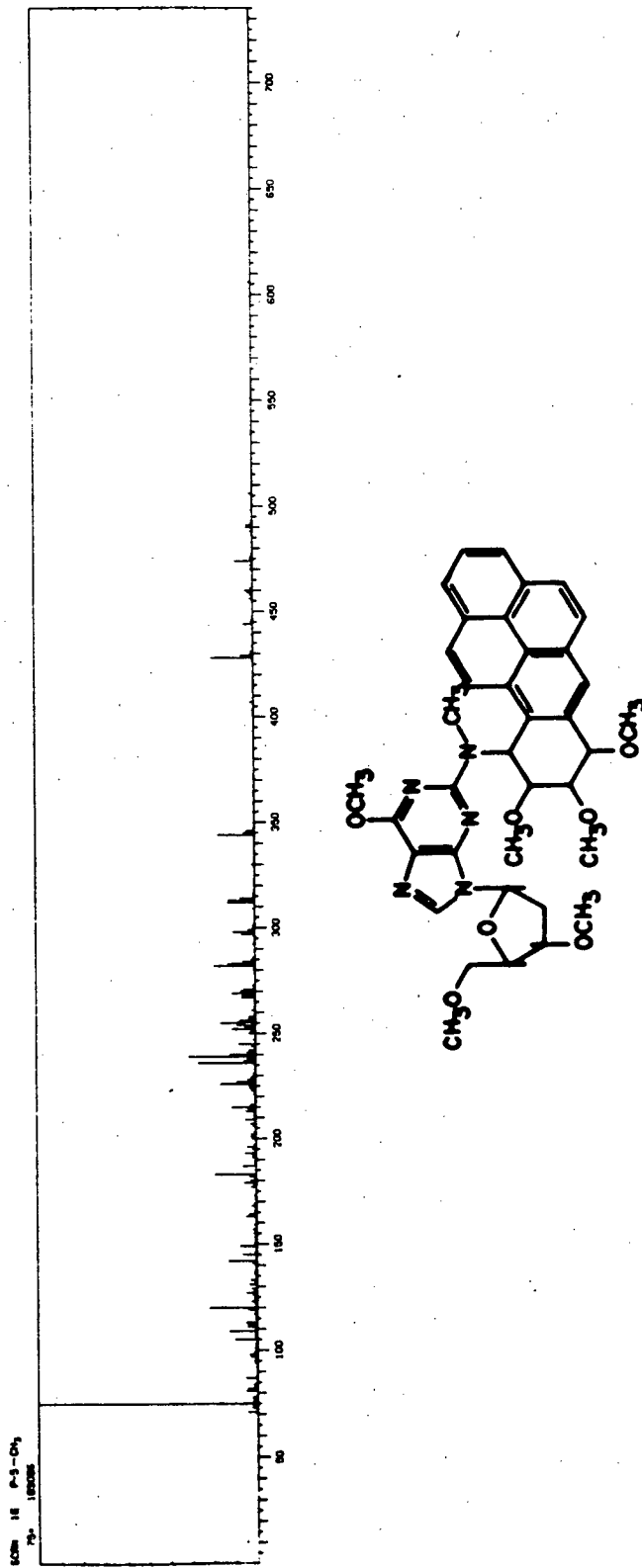

Figure 8a

HIGH RESOLUTION MASS SPECTRUM OF P-5 CH₃



XBL 778-4593

Figure 8 b

HIGH RESOLUTION MASS SPECTRUM OF P-7 CH₃

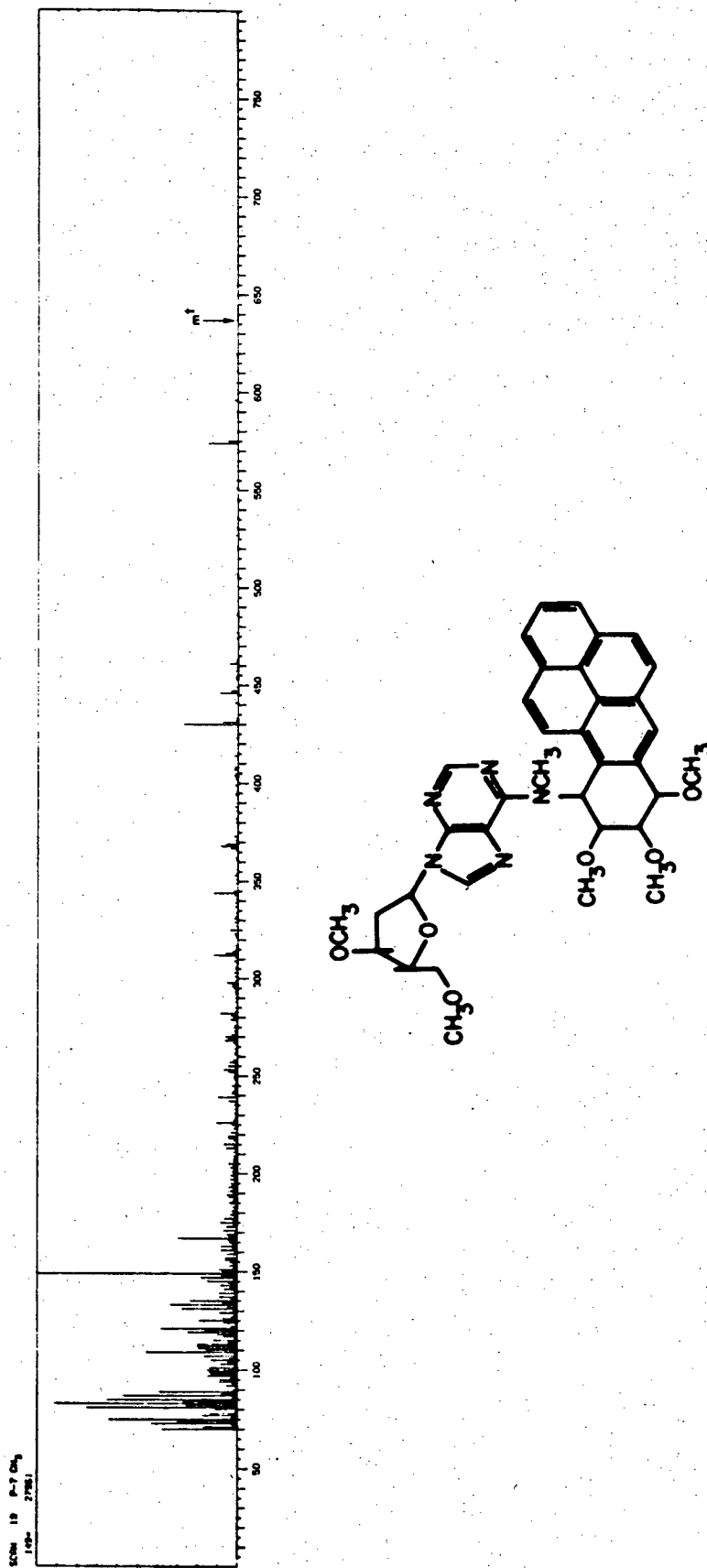

Figure 8c

XBL 778 - 4591

HIGH RESOLUTION MASS SPECTRUM OF P-5 TMS

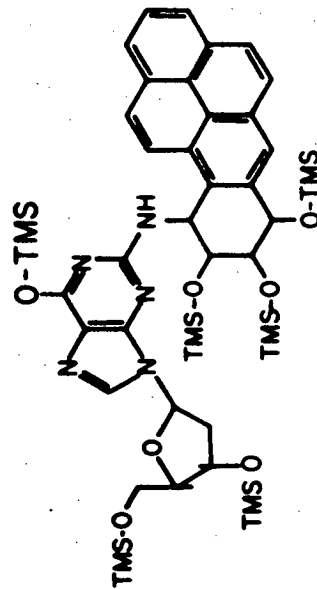
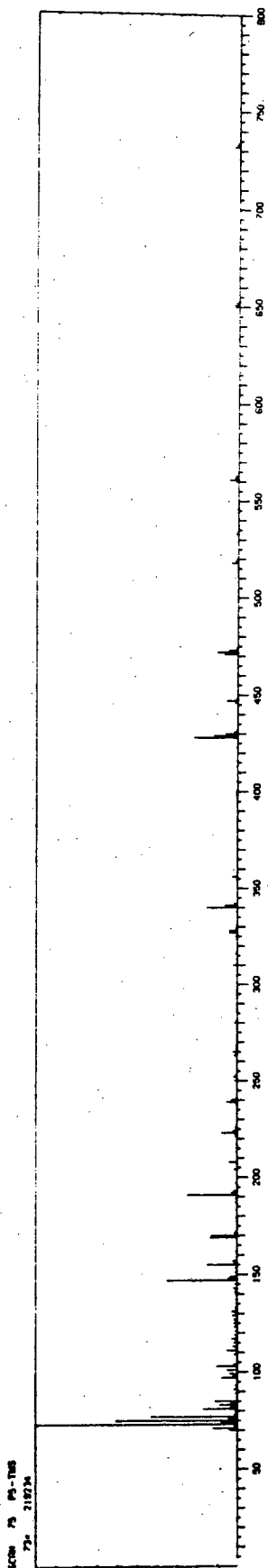

Figure 8d

XBL 778-4594

the following procedure was used: all six spectra should exhibit the same ions originating from the hydroxy-tetrahydrobenzo(a)pyrene moiety, assuming the products involve simple alkylation events between the diol epoxide and DNA alkylation site. After these ions were identified, the unmodified sugar fragments were found. Analysis of the data for fragments due to the purine or pyrimidine could then be carried out.

All six spectra (P2-P7) exhibit the expected ions due to fragmentation of the hydrocarbon moiety corresponding to cleavage of the hydrocarbon-nucleoside bond (see Table 2). This cleavage generates a trimethoxy-tetrahydrobenzo(a)pyrene moiety at m/z 345 (composition $C_{23}H_{21}O_3$, ion "a" in Figure 9). Other ions are then generated by successive loss of the elements of CH_3OH , leading to the fully aromatized monohydroxybenzo(a)pyrene species at m/z 267 ($C_{20}H_{11}O$). This fragment can then lose CO to give the major ion at m/z 239 ($C_{19}H_{11}$). These fragmentation processes are outlined schematically in Figure 9.

Table 2

Fragments Derived from Hydrocarbon Moiety of Permethylated Adducts
(P2 - P7)

m/z	Elemental* Composition
345	$C_{23}H_{21}O_3$
344	$C_{23}H_{20}O_3$
313	$C_{22}H_{17}O_2$
312	$C_{22}H_{16}O_2$
298	$C_{21}H_{14}O_2$
297	$C_{21}H_{13}O_2$

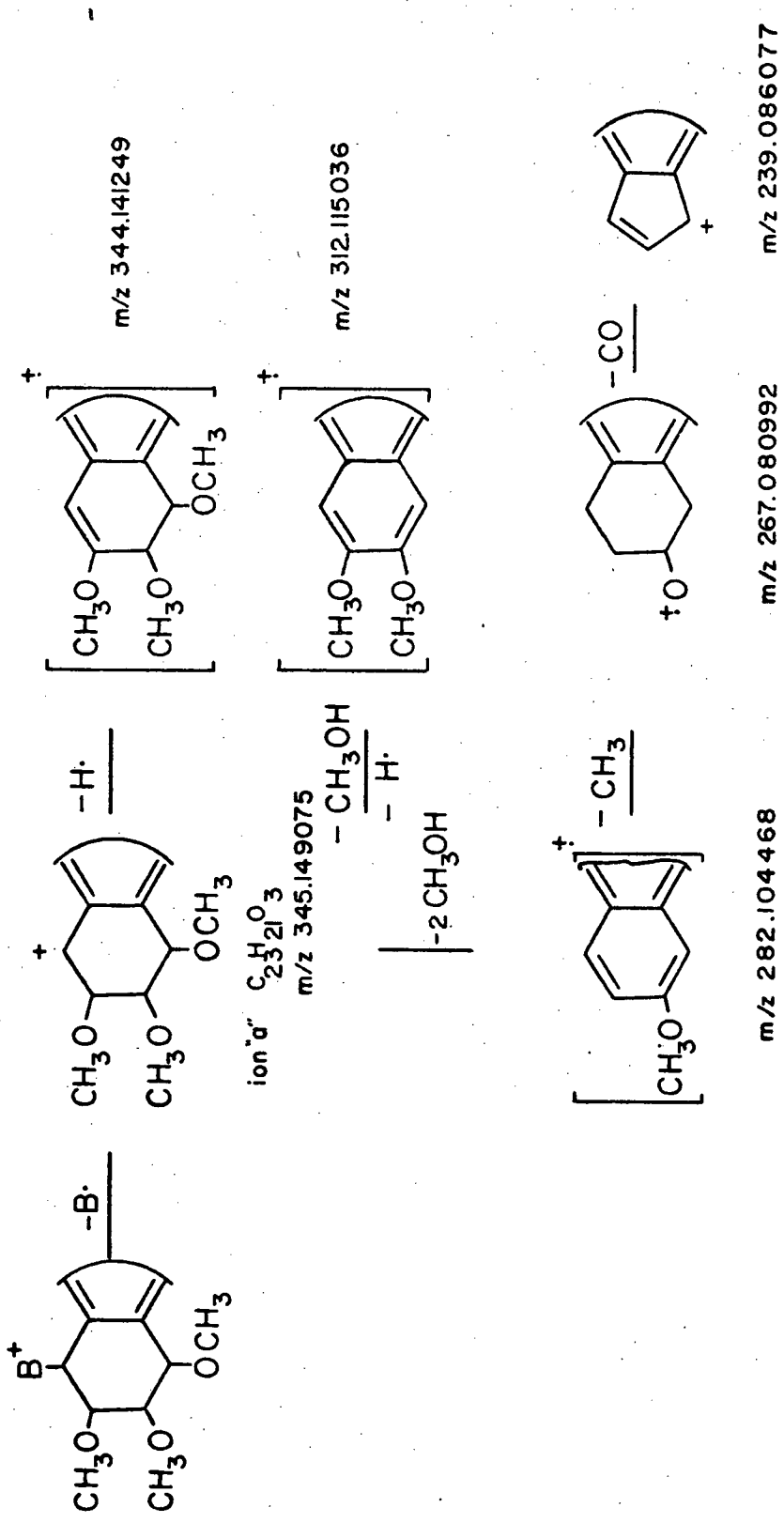

Figure 9: Hydrocarbon ions derived from permethyl diol epoxide - DNA adducts

Table 2 (continued)

m/z	Elemental * Composition
282	C ₂₁ H ₁₄ O
267	C ₂₀ H ₁₁ O
239	C ₁₉ H ₁₁
226	C ₁₈ H ₁₀
215	C ₁₇ H ₁₁

* All compositional tolerances are less than 10 ppm for all spectra (P2-P7); masses are listed as nominal values.

A similar search for ions derived from a methylated sugar moiety "s"

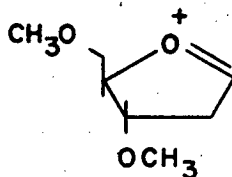

ion "s", m/z 145.086473

revealed that all six spectra contained such ions. These included ion "s" (C₇H₁₃O₃), "s-H" (C₇H₁₂O₃), and "t" (C₄H₇O). No ions corresponding to a trimethoxytetrahydrobenzo(a)pyrene- sugar fragment were found. The point of attachment of the hydrocarbon moiety is therefore not through the deoxyribose unit.

Assignment of the specific purine or pyrimidine in each adduct can be deduced from the fragmentation patterns of permethyl P1- P7 by the presence or absence of specific marker ions. Thus guanine-

containing peaks should exhibit an N_5O_1 series of ions, adenine an N_5 series, cytosine an N_3O_1 series, and thymine an N_2O_2 series. These ions should be evident in fragmentations involving loss of the deoxyribose to generate a "base + H" series of ions. Table 3 shows the results obtained for permethyl P2 through P7; in all cases fragments due to the heterocyclic base are of high relative intensity. This allows the assignment of each adduct to a particular nucleoside. Thus, permethyl-P7 (and permethyl-P6) has an intense ion at m/z 149.070127 ($C_6H_7N_5$) corresponding to a monomethyladenine. Another ion at m/z 119.03567 ($C_5H_3N_4$) corresponds to loss of the elements of CH_3N from the intact base. Similarly, permethyl-P5 (and permethyl-P3) has an ion at m/z 179.080614 ($C_7H_9ON_5$), indicative of dimethylguanine. This elemental composition was confirmed by perdeutero-methylation, which gave m/z 185.119264 ($C_7H_3D_6ON_5$). Permethyl-P2 (and permethyl-P4) has a low intensity ion at m/z 125.059345 ($C_5H_7ON_3$) corresponding to monomethylcytosine, with an intense ion at m/z 111.044149 ($C_4H_5ON_3$).

Table 3

Fragments Derived from the Nucleoside Base Moiety of Permethylated
Adducts (P2 - P7)

Adduct	m/z	Elemental Composition	Error (ppm)
P2(P4)	125.059345	C ₅ H ₇ N ₃ O	+ 3.44
	112.051423	C ₄ H ₆ N ₃ O	+ 2.97
	111.044149	C ₄ H ₅ N ₃ O	+ 7.97
P5(P3)	179.080614	C ₇ H ₉ ON ₅	+ 0.558
	150.055164	C ₆ H ₆ ON ₄	- 6.66
P7(P6)	149.070127	C ₆ H ₇ N ₅	- 0.15
	120.043705	C ₅ H ₄ N ₄	- 0.89

The overall fragmentation for each adduct is dominated by the stability of the aromatic hydrocarbon and purine or pyrimidine moieties. The results obtained for permethyl-P7 serve to illustrate this point. A molecular ion is observed at m/z 637.298619 (C₃₆H₃₉O₆N₅). Successive losses of the elements of methanol give m/z 605.264151 (C₃₅H₃₅O₅N₅) and 574.247171 (C₃₄H₃₂O₄N₅), and loss of the elements of both CH₃OH and the deoxyribose gives m/z 461.186074 (C₂₈H₂₃O₂N₅) and 430.169208 (C₂₇H₂₀O₂N₅). Cleavage of the hydrocarbon-purine bond results in the hydrocarbon and base ions discussed above. Permethyl-P2 (and permethyl-P4) gave similar results, except that a molecular ion (expected at m/z 613.278812) was not observed. The highest mass ion, m/e 469.200108 (C₂₈H₂₇O₄N₃), corresponds to loss of the deoxyribose from a cytosine-diol epoxide adduct. Successive losses of the elements of CH₃OH result in m/z 437.188883 (C₂₇H₂₃O₃N₃) and 406.155525 (C₂₆H₂₀O₂N₃). Cleavage of the

hydrocarbon-pyrimidine bond then results in the hydrocarbon and base series of ions.

Von Minden and McCloskey have presented extensive data on the fragmentation patterns of permethylated nucleosides.¹²¹ A characteristic ion for permethyl deoxyguanosine, permethyl deoxyadenosine, and permethyl deoxycytidine involves the "base + H" ion (loss of deoxyribose; see Figure 7) which includes a dimethylamino function. This species can then lose methyleneimine (CH_2NH) or the entire dimethylamine function. In the spectra reported here, dimethyladenine or dimethylcytosine ions were not found; only monomethyl adenine or cytidine were observed. For the adenosine adduct (permethyl-P7 and -P6), this indicates that direct linkage of the diol epoxide moiety to the purine (eg. C-8) does not occur. The occurrence of a relatively low abundance (1.9% relative intensity) nitrogen-containing hydrocarbon fragment at m/z 279.104802 ($\text{C}_{21}\text{H}_{13}\text{N}$) suggests bonding through the N^6 exocyclic amino group. The apparent high stability associated with the benzylic carbonium ion formed by cleavage of the hydrocarbon-nucleoside bond (ion "a", Figure 8) explains the relatively low intensity of these nitrogen-containing hydrocarbon fragments. For permethyl-P2 (and permethyl-P4), no such ion could be found, leaving open the possibility of alkylation via the O^2 , N^3 , or N^4 positions of cytosine. A tautomeric structure for the adenosine adduct such as "A" (N^1) or "B" (N^3)

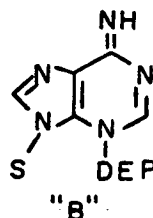
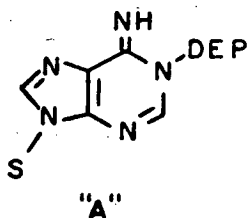

is not indicated by data obtained on the pertrimethylsilyl derivative of P7(P6); both "A" and "B" would be expected to generate a mono-trimethylsilyl adenine species, which was not observed. The N⁶- adduct, however, should yield a free adenine (steric hindrance prevents addition of a TMS group to the diol-epoxide substituted N⁶ position).

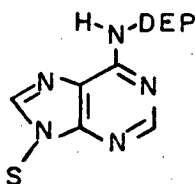

The major component, permethyl-P5, contains guanine but otherwise follows the same general fragmentation scheme observed for permethyl-P7 and permethyl-P2. High mass ions include m/z 523.222675 ($C_{30}H_{29}O_4N_5$, M^+ - deoxyribose), followed by successive losses of the elements of CH_3OH to give m/z 490.186904 ($C_{29}H_{24}O_3N_5$), 459.172173 ($C_{28}H_{21}O_2N_5$), and the major ion 428.151793 ($C_{27}H_{18}ON_5$, 19.3% relative intensity). Elemental compositions of all major ions were confirmed by perdeuteromethylation with CD_3I . A molecular ion is not observed in the electron-impact spectrum; the highest mass ion that occurs is at m/z 604.253408 ($C_{35}H_{34}O_5N_5$, M^+ - ($CH_3OH + CH_3O$)). The molecular weight for underivatized P5 was therefore obtained by low resolution field desorption mass spectrometry (FDMS). The field desorption spectrum of P5 consisted of peaks at m/z 569 and 592 (569 + Na), confirming its identity as a deoxyguanosine adduct. (see Appendix A for additional FD data). The electron-impact fragmentation pattern of the base-containing ions does not permit assignment of the alkylation site on guanine. In particular, no nitrogen-containing hydrocarbon ion could be found, making it diffi-

cult to distinguish between N² or O⁶ alkylation. Alkylation at C-8 or other ring positions of the purine would be expected to generate a trimethylguanine species, which was not found. The absence of a trimethoxy tetrahydrobenzo(a)pyrene containing nitrogen is again presumably due to the high stability associated with ion "a" (Figure 9). A pertrimethylsilyl ether of P5 was therefore prepared in order to obtain additional structural information. The composite nominal mass spectrum of pertrimethylsilyl-P5 is shown in Figure 8D. Table 4 lists the major ions observed for pertrimethylsilyl-P5. The overall pattern is similar to that of the permethylated derivatives; loss of the deoxyribose followed by successive losses of trimethylsilanol [(CH₃)₃SiOH] to give m/z 561.209929 (C₃₁H₃₁O₂N₅Si₂). This is then followed by cleavage of the base-hydrocarbon bond to give the base (m/z 223.088141, C₈H₁₃ON₅Si) or hydrocarbon series of ions. In this case, however, a relatively low intensity ion corresponding to a nitrogen-containing BaP species observed at m/z 355.142199 (C₂₃H₂₁ONSi, 0.2% relative intensity). This is consistent with alkylation on the N²-exocyclic amino group, as was reported for the alkylation of poly(G) by anti-diol epoxide (Nakanishi et al.),^{130,131} and syn-diol epoxide (Jerina et al.).¹³²

Table 4

Major Fragments Found for Pertrimethylsilyl(TMS)-P5		
m/z	Elemental Composition	Error (ppm)
732.290461	$C_{30}H_{19}O_4N_5(TMS)_3$	+ 6.39
650.242428	$C_{25}H_{13}O_3N_5(TMS)_3$	- 2.28
561.209929	$C_{25}H_{13}O_2N_5(TMS)_2$	+14.70
518.211532	$C_{20}H_{11}O_3(TMS)_3$	-2.62
472.156874	$C_{25}H_{13}ON_5(TMS)$	- 5.29
428.165375	$C_{20}H_{10}O_2(TMS)_2$	+ 6.03
356.121428	$C_{20}H_{11}O_2(TMS)$	- 5.15
355.142199	$C_{20}H_{12}ON(TMS)$	+ 8.31
223.088141	$C_5 H_4 ON_5(TMS)$	- 3.60

The results of the HRMS study on P1- P7 are fully consistent with the double-label studies described at the beginning of this chapter: P3 and P5 are deoxyguanosine adducts, P6 and P7 are deoxyadenosine adducts, and P2 and P4 are deoxycytidine adducts. P1 and P4 (in addition to the deoxycytidine adduct) contain the two stereoisomeric tetrahydro-tetrahydrobenzo(a)pyrenes formed by hydrolysis of (+)anti-diol epoxide. Interpretation of the mass spectra fragmentation patterns is most consistent with binding to the exocyclic amino groups of guanine (N^2) and adenine (N^6), while cytosine may involve O^2 , N-3, or N^4 alkylation. In the absence of NMR studies (requiring between 10^2 and 10^3 times as much material as could be obtained for the HRMS study), further structural assignments cannot be made. Model compound studies by Jerina *et al.*¹⁰¹ and Harvey *et al.*¹⁰³ have shown that the reaction of nucleophiles (aniline, t-butanol, p-nitrophenol) with both syn and

anti-diol epoxides occurs exclusively at C-10 of the hydrocarbon. The ratio of cis to trans addition at C-10 varies with conditions (trans usually predominates), but both products could be formed (for example, hydrolysis of (+)anti-diol epoxide at neutral pH gives both cis and trans addition products in a 55:45 ratio). The relationship between P2 and P4, P6 and P7, and P3 and P5 could involve cis/trans stereoisomeric products (such isomers would probably exhibit virtually identical fragmentation patterns at 70 eV), although evidence available at this time from other groups working with the two diol epoxides XXIV and XXV suggested an alternate explanation. The relationship between the stereoisomeric adduct pairs is explored in chapter 5. At this point the structures of the adducts P2 (P4), P5 (P3), and P7 (P6), could be represented as IV, II, and III, respectively (figure 10).

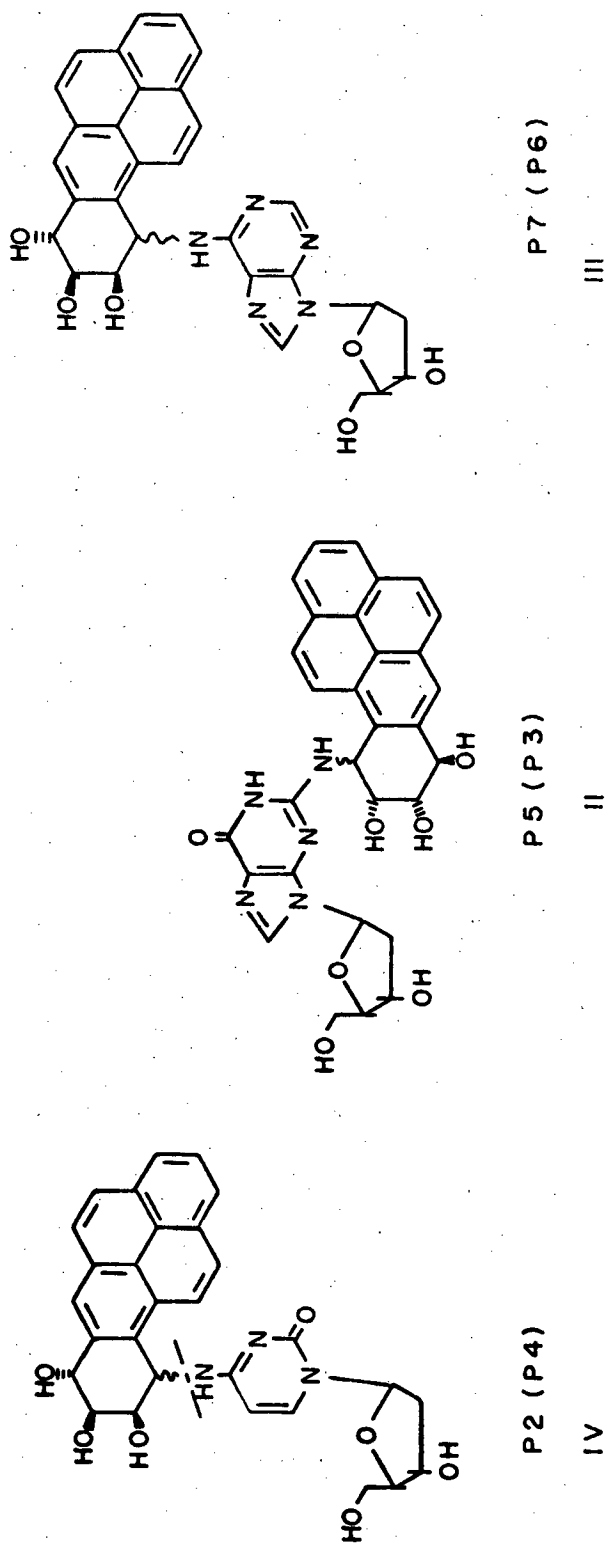

Figure 10 : Structures of (+)anti diol-epoxide-DNA adducts

Experimental

Adduct Formation and Isolation. Formation of microsomal enzyme-activated BaP-DNA adducts was carried out as described in Chapter 2. Diol epoxide-modified DNA was prepared by adding diol epoxide (12 nmol/mg DNA) in 100 μ L of dimethylsulfoxide to a solution of 100 mg calf thymus DNA (Sigma Chemical Co.; St. Louis, Missouri) in 100 mL of 10mM phosphate buffer (pH 7.2) at 37⁰. After twenty-four hours, unbound diol epoxide and its hydrolysis products were removed by repeated extraction with ethyl acetate. The DNA solution was then made 0.2M in sodium chloride and heated for fifteen minutes with three volumes of ethanol. After cooling, the DNA was isolated by centrifugation at 14000 x g for thirty minutes. The isolated DNA was then redissolved in 100 mL of 0.2 M sodium chloride and ethanol precipitated a second time. After centrifugation, the DNA was lyophilized to remove all traces of ethanol.

This procedure was successfully scaled down for working with as little as 100 μ g of DNA. Both SV40 and ϕ X174 viral DNA's were treated using this procedure.

Enzymatic Hydrolysis. DNA samples were dissolved in .015 M sodium acetate buffer (pH 5.00) containing EDTA (2 mM). This solution was then incubated at 37⁰ according to the following schedule (for 100 mg DNA in 20 mL buffer).

Time (hours)	DNAase-II*	phosphodiesterase-II*
0	4000 units	-
8	4000 units	-
16	4000 units	20 units
24	4000 units	20 units

*DNAase-II (Deoxyribonuclease-II, E.C.3.1.4.6) and phosphodiesterase-II (E.C.3.1.4.18) were obtained from Sigma Chemical Co., St. Louis, Mo.¹³³

After 36-40 hours, the pH of the solution was readjusted to 8.5 with 0.1 M NaOH, and fifteen units of alkaline phosphatase (E.C.3.1.3.1; Sigma "type III") was added. This solution was incubated at 37° for six hours and then lyophilized to dryness.

Chromatography. Large (50-100 mg) hydrolyzed DNA samples were chromatographed on a 2.5 x 40 cm column of Sephadex-LH20 (Pharmacia Fine Chemicals, Uppsala, Sweden), eluted with a linear gradient of .02 M NH_4HCO_3 (pH 8.2)-methanol. Fractions were sampled for the presence of ^3H (in the case of ^3H -labelled diol epoxide or benzo(a)-pyrene) by scintillation counting in Aquasol-2 (New England Nuclear, Boston, Massachusetts).

Small (0.1- 1.0 mg) hydrolyzed DNA samples were chromatographed on a micro-column (0.5 x 5 cm) of Sephadex LH20 by eluting with one column volume of .02 M NH_4HCO_3 (pH 8.2) buffer, followed by two column volumes of methanol. Modified nucleoside residues were observed to elute from the column with the methanol fraction.

High pressure liquid chromatography (HPLC) was carried out on two 4.1 mm x 30 cm μ -Bondapak C_{18} reverse phase columns (Waters Associates,

Milford, Massachusetts), using either a modified Varian Model 8500 liquid chromatograph (Varian, Palo Alto, California) or a Waters 6000A solvent delivery system (Waters Associates, Milford, Massachusetts). Water-methanol was used as an eluant, at a flow rate of 1 ml/min. The column effluent was monitored for either absorbance (Schoeffel 770 variable wavelength detector) or fluorescence (Schoeffel FS 970 fluorescence detector, Schoeffel Instruments, Westwood, New Jersey). The fluorescence detector incorporates an excitation monochromoter in conjunction with a photomultiplier tube for detection. For compounds that contain a pyrene-like chromophore, the fluorescence detector (using 248 nm for excitation and greater than 370 nm for detection) was found to be 100-1000 times more sensitive than absorbance at 254 nm. As little as 25-50 pg of material could be detected with this system. Column effluent was also monitored for ^3H or ^{14}C by scintillation counting of fractions in Aquasol-2 (New England Nuclear, Boston, Massachusetts). At the specific activities available to us (1-10 Ci/mmol for ^3H , 50 mCi/mmol for ^{14}C), fluorescence detection was approximately as sensitive as radioactivity.

Labelled DNA Synthesis. DNA-polymerase I (E.C. 2.7.7.7) was obtained from either Boehringer-Mannheim (Indianapolis, Indiana) or by isolation from E. coli by the method of Kornberg (performed by Dr. Thomas Meehan and Vincent McGovern, Laboratory of Chemical Biodynamics, Lawrence Berkeley Laboratory). Synthesis mixtures contained (per mL) 66 μmol of potassium phosphate buffer (pH 7-0), 6.6 μmol of MgCl_2 , 1 μmol of 2-mercaptoethanol, 50 m μmol each of dATP, dGTP, dCTP, and dTTP (one of which contained ^3H , with a specific

activity of 10-30 Ci/mmol), 30 μ mol of untreated calf thymus DNA, and six units of polymerase. The reaction mixture was incubated at 37^o, and the extent of synthesis measured by removing aliquots and assaying for the production of acid-insoluble radioactive material by the method of Schildkraut *et al.*¹³⁴ Unincorporated nucleoside triphosphates were removed by dialysis, and the ³H-labelled DNA purified by isopropanol precipitation. Reactions with diol epoxides were carried out with approximately 100 μ g of labelled DNA plus template.

Chemical Derivatization Procedures. (a) Permethylation: a modification of the procedure originally developed by Hakamori was used.^{122,128} Two hundred mg of sodium hydride (1:1 oil dispersion) was washed exhaustively with dry ethyl ether, and then added to 8 mL of dimethylsulfoxide. This mixture was heated under argon at 65^o for fifty minutes. The resulting honey-colored solution was approximately 0.5 M in methyl sulfinyl carbonion, and was sufficiently stable to use over a period of 1-4 hours. This solution contains 5×10^{-7} molar equivalents of anion per μ L. The compound to be derivatized (0.1 - 1.0 μ g) was dissolved in 40 μ L of dimethylsulfoxide in a small (300 μ L) conical vial. Seventy molar equivalents of anion (i.e., approximately 10 molar equivalents per exchangeable hydrogen in the compound) were added, the solution vortexed, and then approximately 70 molar equivalents of methyl iodide (or d₃-methyl iodide) were added. The solution was again vortexed, and the reaction stopped after 60 - 90 seconds by the addition of 1 mL of water. The methylated product was extracted into 1 mL of chloroform, washed several times with water, and concentrated to a final volume of ~ 5 μ L.

Permethylated adducts were routinely analyzed by HPLC (using reverse phase columns) to confirm that a single product was present before attempting to obtain a mass spectrum.

(b) Pertrimethylsilylation: TMS derivatives of nucleosides and adducts were prepared by a modification of the procedure of Sjöval.¹³⁵ The compound to be derivatized was treated with 1 mL of a 1:1 mixture of pyridine and trimethylsilyl imidazole (TSIM, Pierce Chemical Co., Rockford, Illinois) at 100° for three hours. After cooling, the reaction mixture was applied to a 0.5 x 5 cm column of Lipidex 5000 (Packard Instruments, Warrenville, Illinois). The TMS-ether was eluted with cyclohexane containing 1% trimethylsilylchloride, and this solution concentrated to a final volume of 15 μ L. Per-TMS ethers are rapidly hydrolyzed when evaporated to dryness on a glass surface.

Mass Spectrometry. Low resolution electron-impact mass spectra were obtained by direct insertion probe on either a duPont model 21-492-1 mass spectrometer equipped with a model 21-094B data system, or on a Hitachi M52 mass spectrometer equipped with a non-commercial data system. High resolution electron impact mass spectra were obtained on a modified Kratos/AEI-MS902 mass spectrometer interfaced with a LOGOS-II/Xerox-Sigma 7 data system.^{118,119} This system automatically assigns exact masses (dynamic resolution $\geq M/\Delta M$ 10,000) to all of the observed fragment peaks in a mass spectrum and stores the data on disc or tape. Elemental compositions for each peak are then generated by computer for a given error tolerance.

Chapter 5: Stereoselective Binding of Proximate Carcinogens to DNA

The complexity of DNA as a target nucleophile prompted speculation about the maximum number of products that one would expect to observe in the reaction of (+) anti-diol epoxide with DNA. The problem is complicated somewhat by the different levels of asymmetry present in DNA. Each deoxyribose moiety contains an asymmetric center at C-1', and the Watson-Crick double helix has an overall right-handed twist.¹³⁶ The synthetic diol epoxides used in the experiments described in chapter 4 were synthesized as racemic mixtures, containing both the (+) and (-) enantiomers. Thus the reaction of a (+) diol epoxide with a nucleoside would be expected to result in two diastereomeric products, each having two asymmetric centers (C-1' of the sugar and the asymmetric substituted benzo(a)pyrene moiety) but differing from each other in one center only (the asymmetric substituted benzo(a)pyrene). In addition to this, the reaction in each case can proceed by cis or trans ring-opening of the epoxide at C10 of the hydrocarbon. In theory, then, each alkylation site on a purine or pyrimidine residue of DNA should result in four diastereomeric (and therefore chemically different) products. In actual practice, however, not all products may actually be formed under a given set of experimental conditions. A number of investigators have studied the reactions of both syn and anti-diol epoxide with small nucleophiles such as t-butylthiolate, methoxide, p-nitrophenolate, and aniline^{101,103}; with such nucleophiles ring-opening of the epoxide was observed to be highly trans-stereoselective. This suggests an SN₂ mechanism. In all cases addition

of the nucleophile occurs at C-10:¹³⁷

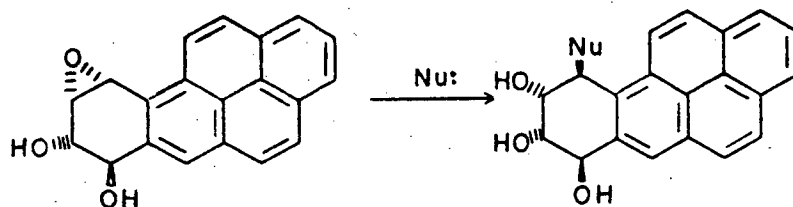

SN_1 appears to be the dominant mechanism for reaction with weaker nucleophiles. Hydrolysis or methanolysis results in substantial amounts of cis ring-opened products for both the syn and anti diol epoxides. It is evident that the ratio of cis to trans ring-opened products is dependent on solvent, pH, ionic strength, and the nature of the target nucleophile.¹¹⁵

The reactions of both the syn and anti-diol epoxides with a model nucleic acid, poly(G), have been studied extensively by Weinstein et al. and Jerina et al.^{130,132} In both cases the major product was observed to be a trans-substituted N^2 -guanosine adduct:

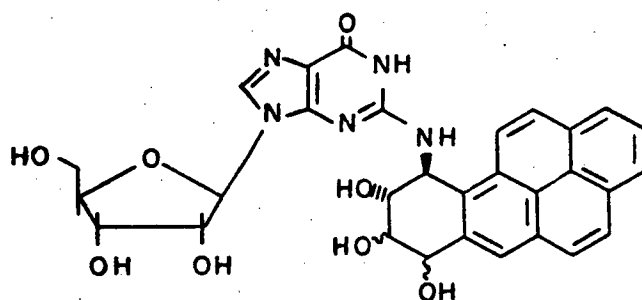

Each reaction gave two major products, identified as adducts between the (+) and (-) diol epoxide enantiomers and guanosine (with its D-ribose asymmetric center). One or two minor products were observed, and are believed to be the cis ring-opened products.¹³⁸ We decided to

repeat these experiments in order to verify that our HPLC system was capable of resolving such closely related diastereomers. Figure 1 represents an HPLC fluorescence trace of the modified nucleosides derived from the reaction of (+) anti-diol epoxide with poly(G). Identical results were obtained with both hydrolysis by base and enzymatic (ribonuclease T₁) digestion. The circular dichroism (CD) spectra of the two major components (peaks 1 and 2) are also reproduced in figure 1; they are of approximately opposite and equal shape and intensity. This relationship between the two CD traces was not entirely expected since the two products ((+)anti-diol epoxide/ guanosine and (-)anti-diol epoxide/ guanosine) are diastereomers rather than enantiomers. The contribution of the enantiomeric substituted tetrahydrobenzo(a)pyrene moiety apparently dominates the CD spectrum, minimizing any contribution from the D-ribose. Two minor components are evident in the HPLC profile, and probably correspond to the cis ring-opened products.

We had observed six products in the reaction of (+) anti-diol epoxide with native calf thymus DNA, referred to in chapter 4 as P2-P7. These products were identified as two pairs each of deoxyguanosine, deoxyadenosine, and deoxycytidine adducts. The discussion above indicates that we should observe four products per alkylation site: cis and trans (+)anti-diol epoxide/ nucleoside, and cis and trans (-)anti-diol epoxide/ nucleoside. The ratio of trans to cis ring-opened products is difficult to predict, but the trans isomers would be expected to predominate. Alternatively, the ratio of trans to cis ring-opening could be determined by stereochemical effects prior to covalent binding (eg., intercalation). Thus the presence of cis ring-opened products cannot be ruled out solely on the basis of studies conducted

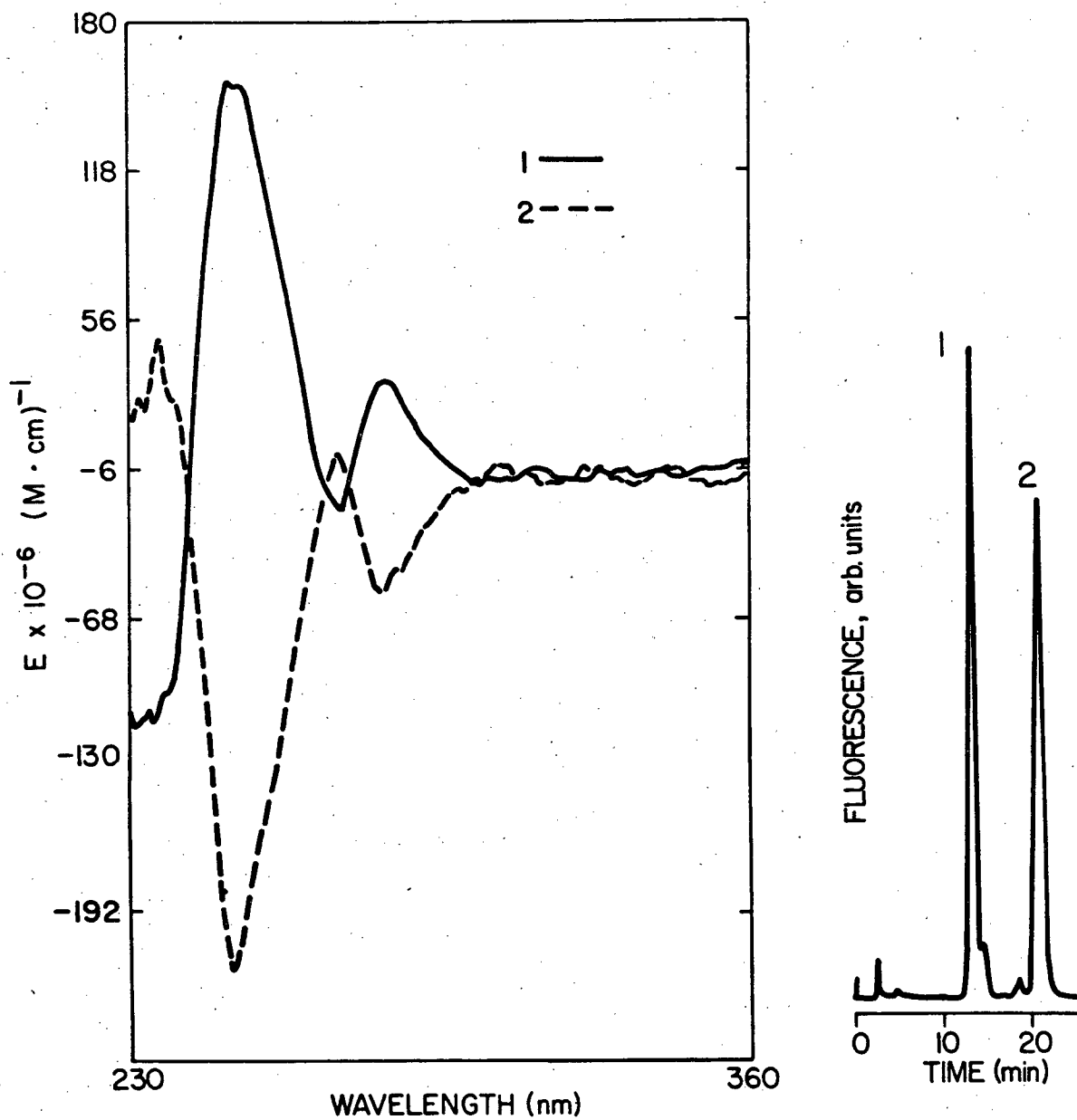
HPLC PROFILE AND CD SPECTRA
DEP-POLY(G) ADDUCTS

XBL778-4543

Figure 1

with model nucleophiles such as aniline. When increased levels of (+) diol epoxide are used to modify DNA, more products begin to appear. Figure 2 represents an HPLC trace of the modified nucleosides recovered from calf thymus DNA which was reacted with (+)anti-diol epoxide at a ratio of 2500 nmol/ mg of DNA. This results in a highly modified DNA (>1 hydrocarbon residue per 100 base pairs) that is somewhat difficult to degrade by enzymatic digestion; only about 40% of the diol epoxide-modified residues could be recovered as monomers. The original adducts (P1-P7) obtained at low modification levels are marked on the trace in figure 2. Identifying all of the unknowns in this figure represents a formidable analytical challenge, as most products are available in sub-microgram quantities.

In order to characterize the various products observed in figure 2, we considered it essential to first identify which products involved the (+) or (-) enantiomers of the anti-diol epoxide. Comparison of CD spectra for each peak was not entirely successful because of the difficulty in isolating products completely free of any contaminating materials. Also, some of the peaks represented in figure 2 were later shown to contain more than one component. We therefore undertook to resolve the enantiomers of the anti-diol epoxide and to react each separately with DNA. Yang and co-workers had previously shown that metabolism of benzo(a)pyrene to trans-7,8-dihydroxy-7,8-dihydrobenzo(a)pyrene was stereospecific, resulting in exclusive formation of the single enantiomer (-)r-7,t-8-dihydroxy-7,8-dihydrobenzo(a)pyrene.¹³⁹ The absolute configuration of this enantiomer was subsequently determined using the exciton chirality method developed

Figure 2: Adducts from DNA modified by (±)anti-diol epoxide at 2500 nmol/mg DNA

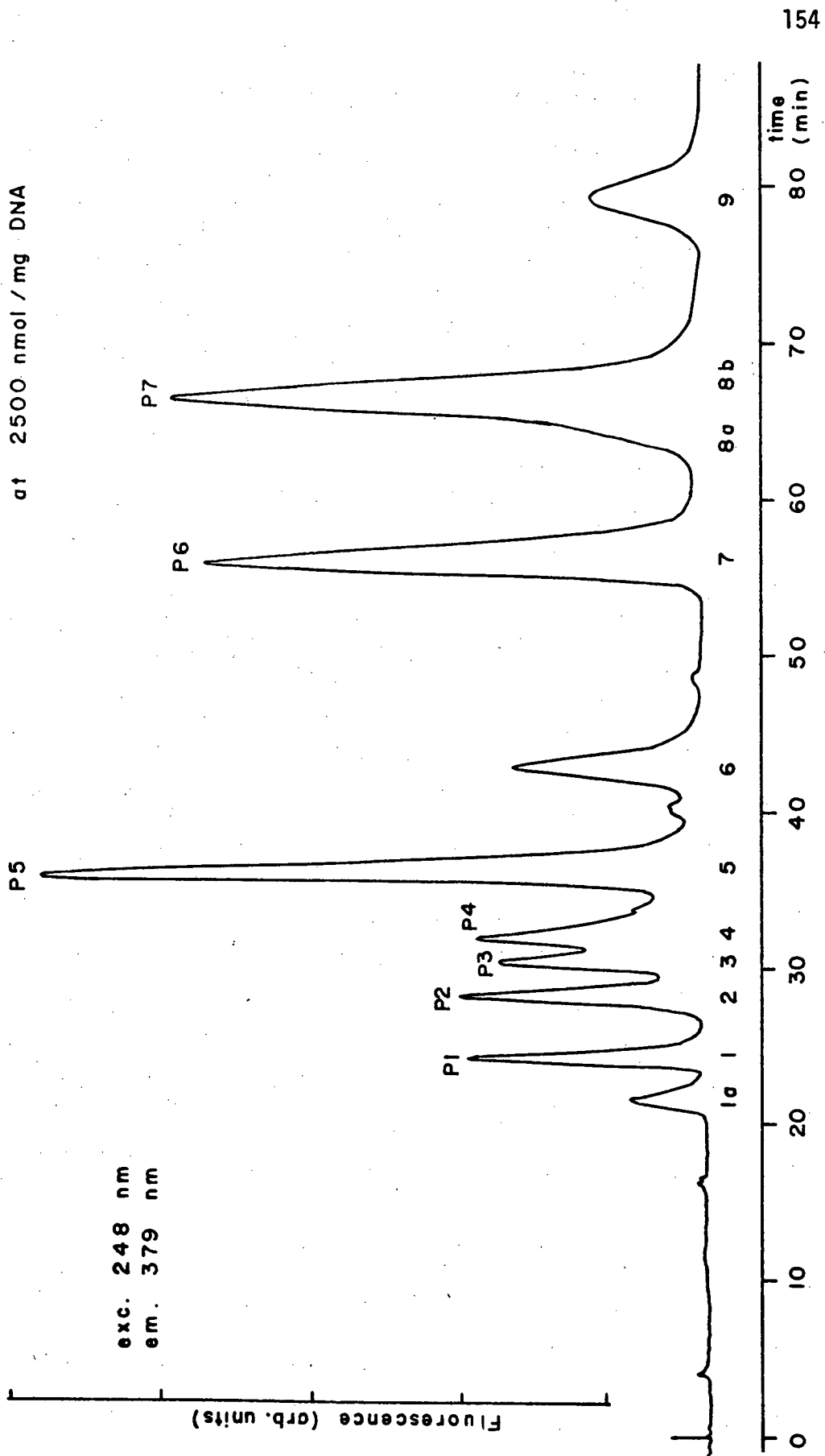

by Harada and Nakanishi.¹⁴⁰

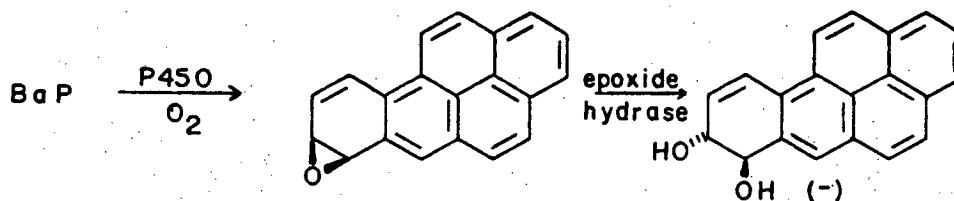

We therefore used the method of Yang to resolve the (+) and (-) trans-7,8-diols,¹⁴¹ and then converted each separate diol enantiomer to the corresponding anti-diol epoxide enantiomer on a micro-scale (ca. 1 mg). The racemic 7,8-diol was converted to a pair of diastereomeric esters by reaction with (-) menthoxy acetyl chloride. These were separated by HPLC (5 μ silica, eluted with hexane-dichloromethane) and then hydrolyzed to free trans-diol enantiomers by reaction with sodium methoxide in methanol. Each enantiomeric diol was then converted to the (+) and (-) anti-diol epoxide, respectively. Yang *et al.*¹⁴², Weinstein *et al.*¹⁴³, and Jerina *et al.*¹⁴⁴ have independently assigned the absolute configurations of the anti-diol epoxide enantiomers, as shown below:

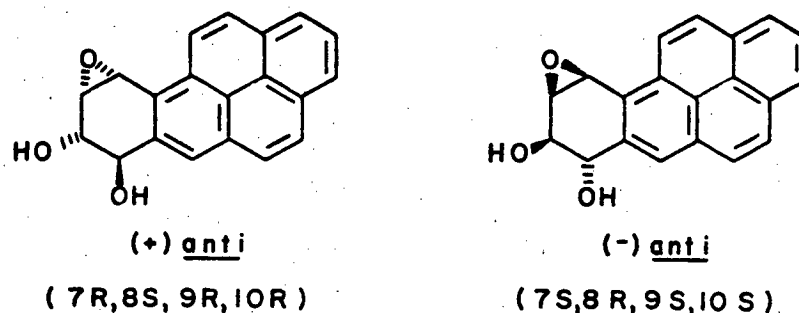

After synthesis, the resolved anti-diol epoxides were reacted separately with native DNA under standard reaction conditions (chapter 4). The results of this study are outlined in figure 3: the top trace (a) represents the adducts obtained from the reaction of racemic (+)

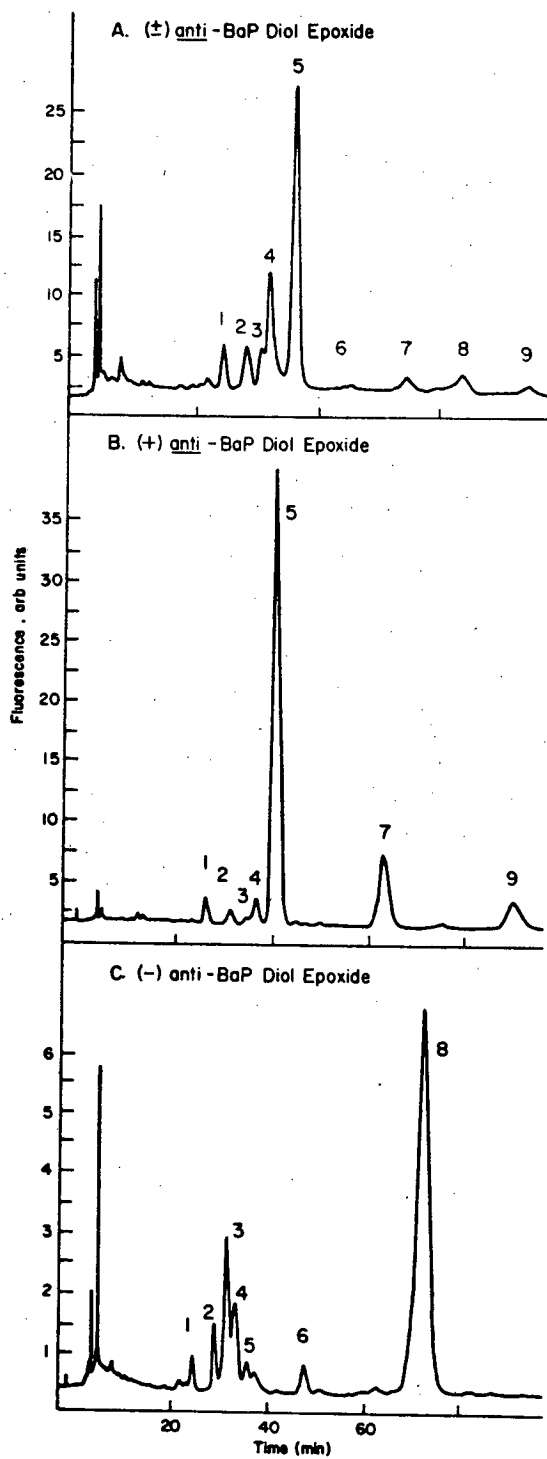

XBL786-4046

Figure 3

anti-diol epoxide with DNA, and the other two traces (b and c) represent the products obtained by reacting the (+) and (-) enantiomers separately. Thus peaks 1,4,5,7, and 9 are derived from (+) anti-diol epoxide, and peaks 1,3,4,6, and 8 are derived from (-) anti-diol epoxide. Peak 6 is a minor product, and was not discussed in chapter 4. Peak 7 in figure 3 corresponds to P6 of chapter 4, and peak 8 corresponds to P7. Peak 9 was not discussed in the experiments described in chapter 4, as it was usually a minor product compared to P6 or P7. Peaks 1 and 4 correspond to stereoisomeric 7,8,9,10-tetrahydroxy-7,8,9,10-tetrahydrobenzo(a)pyrenes (cis and trans ring-opening of the epoxide by water). The amount of material in peaks 1 and 4 varies according to the success of the isolation and purification of the modified DNA after reaction with diol epoxide (see Experimental). Peak 2 is a deoxycytidine adduct, and occurs in both enantiomer reactions (b and c, figure 3); peak 4 also contains a small amount of deoxycytidine adduct (see chapter 4). Peak 3 is a (-) anti-diol epoxide-N²-deoxyguanosine adduct, and peak 5 is the corresponding (+) anti-diol epoxide -N²-deoxyguanosine diastereomer. Peaks 7 (P6 in chapter 4) and 8 (P7 in chapter 4) are, respectively, (+) and (-) anti-diol epoxide-N⁶-deoxyadenosine adducts. Peak 9, previously unidentified, was observed to have a high resolution mass spectrum (as a permethyl derivative) identical to peaks 7 and 8, and is therefore identified as a (+) anti-diol epoxide-N⁶-deoxyadenosine adduct. Peak 6, a relatively minor component, had a mass spectrum similar to peaks 3 and 5, and probably corresponds to a (-) anti-diol epoxide-N²-deoxyguanosine adduct (possibly a cis-N² adduct; positive identification of this product will be extremely difficult). The asymmetric shape of peak 8

in figure 3a and 3c suggested the presence of more than one component; when this peak was further resolved using HPLC in a recycle mode,¹⁴⁵ it resulted in two components that had identical field desorption mass spectra (see Appendix A). Peak 8 thus consists of at least two (-)anti-diol epoxide- N⁶-deoxyadenosine adducts.

In the absence of ¹H-NMR data, the positive identification of trans or cis ring-opened products must remain tentative. However, the combination of high resolution mass spectrometry, field desorption mass spectrometry (see Appendix A), and separate enantiomer reactions does allow overall identification of each adduct. On the basis of the model alkylation and poly(G) studies discussed above, it is reasonable to suggest that peaks 7 and 9 represent trans and cis N⁶-deoxyadenosine/(+)anti-diol epoxide adducts, and that peak 8 contains the corresponding (-)anti-diol epoxide diastereomeric adducts. Three deoxyguanosine adducts (peaks 3,5, and 6) are observed; peaks 3 and 5 correspond to the major and, presumably trans addition products of (-) and (+) anti-diol epoxide with the N²-amino group of deoxyguanosine. Peak 6, derived from the (-) enantiomer, could correspond to either an exocyclic amino cis addition product or to a guanine adduct with alkylation at some other site on the purine ring. Only two deoxycytidine adducts (peaks 2 and 4) were observed. The relative contributions of (+) and (-) diol epoxide enantiomers to these two peaks is difficult to assess, as peak 4 also contains varying amounts of the tetraol hydrolysis product.

A detailed comparison of the DNA adducts obtained from the microsomal activation of benzo(a)pyrene with those obtained from the reaction of (+)anti-diol epoxide with DNA indicates that peaks 2,3, and 8

are not present in the microsome-derived material. This is consistent with the results of both Yang *et al.*¹⁴² and Weinstein *et al.*¹⁴³, who showed that metabolism of (-)-7,8-dihydroxy-7,8-dihydrobenzo(a)-pyrene by microsomal enzymes proceeds in a stereospecific fashion to generate the (+)-anti-diol epoxide in high optical purity (>95%). A complete analysis of the products derived from the microsomal activation of benzo(a)pyrene is complicated somewhat by the finding that small (<5% of total) amounts of (-)-syn diol epoxide are also generated metabolically.^{129,146} The present resolution of our HPLC system does not allow complete separation of all of the expected diastereomeric products. Assuming a single alkylation site (*eg.*, exocyclic amino group) for dG, dA, and dC, (+)-anti-diol epoxide and (-)-syn-diol epoxide would each generate six adducts for a total of 12, plus four tetraol hydrolysis products. If the optical selectivity of these enzymatic transformations is not 100%, then one would expect to observe small amounts of the 12 possible adducts derived from both (-)-anti and (+)-syn-diol epoxide (for a total of 24 diastereomeric adducts, and 4 resolvable tetraol isomers). High levels of modification (>2500 nmol/mg of DNA) would be necessary in order to isolate such minor products, and there is evidence that other alkylated species besides the exocyclic amino adducts are formed under these conditions.¹⁴⁷ It is not obvious that such a detailed analysis is either practical or desirable. Under physiological conditions binding to DNA occurs at the level of less than 1 in 10^4 base pairs, which probably limits the type and number of DNA adducts to the species observed in these studies. The possibility nevertheless exists that different types of adducts may have markedly different biological effects, and that

some previously undetected minor product is somehow responsible for major cytotoxic, mutagenic, or carcinogenic effects. The relevance of such speculation must await the outcome of experiments now in progress to study the effect of covalent adducts on cell cycle phenomena, growth control, and DNA structure, function, and repair.

A quantitative analysis of the amount of material present in each peak of figure 3a reveals an unexpected phenomenon, that of stereoselective binding of one enantiomeric diol epoxide over the other. In the reaction of (+)anti-diol epoxide with poly(G) (figure 1), the trans-N² addition products are obtained in a 1:1 ratio (to within 2%). The two minor components (probably corresponding to cis ring-opened products) also occur in a 1:1 ratio. The reaction of (+)anti-diol epoxide with DNA, however, does not appear to generate equal amounts of diastereomeric adduct pairs. This is most evident in comparing peaks 3 and 5, which correspond to (-)anti-diol epoxide N²-deoxyguanosine and (+)anti-diol epoxide N²-deoxyguanosine adducts, respectively (both are probably trans ring-opened products). The ratio of peak 5 to peak 3 (figure 3a) is approximately 20:1 at low modification levels (12 nmol/ mg of DNA, resulting in one adduct per 8000 base pairs). Recovery of bound ³H-diol epoxide as monomeric nucleoside adducts was >95%, based on radioactivity. This stereoselectivity in the preferential binding of enantiomers does not hold for dA adducts (peaks 7,8, and 9 in figure 3), however. In all cases the ratio between (+) and (-) anti-diol epoxide dA adducts (7 + 9, 8) was approximately 1:1. Figure 4 shows the structures of the trans addition products and their per cent distribution obtained by reaction of racemic (+)anti-diol epoxide with native calf thymus DNA.

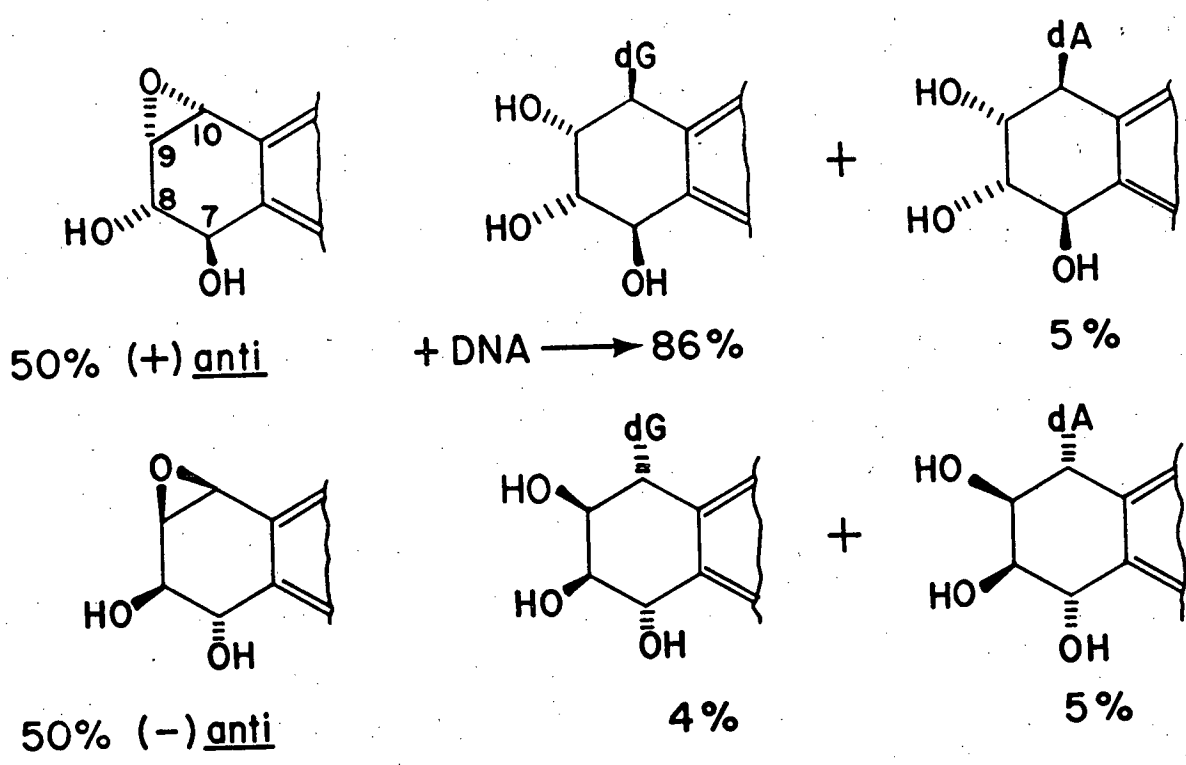

XBL 786-4044

Figure 4

The same ratio of diastereomers was obtained by reaction of the resolved enantiomeric diol epoxides with native calf thymus DNA. The efficiency of binding to dA residues is the same for both enantiomers, but is 20:1 for dG residues. That is, when equimolar quantities of resolved (+) and (-) enantiomers of anti-diol epoxide are reacted with native DNA under identical conditions, the (+) enantiomer becomes covalently bound to a much greater extent than does the (-) enantiomer (since 92% of the stable adducts are with dG residues).

We initially postulated that the stereoselective binding could be the result of the hydrocarbons interacting asymmetrically with the secondary structure of DNA.¹⁴⁸ This postulate was tested by reacting racemic (+) anti-diol epoxide with double and single-stranded ϕ X 174 DNA. The same distribution of stereoselective adducts of guanine was obtained with native calf thymus DNA (figure 3a) as with double-stranded ϕ X 174 DNA (figure 5a). Reaction of racemic (+) anti-diol epoxide with single-stranded ϕ X 174 DNA, however, resulted in a nearly equal distribution of hydrocarbon-deoxyguanosine diastereomers (figure 5b, peaks 3 and 5). In addition, reaction with the single-stranded polydeoxynucleotide resulted in a significantly increased proportion of deoxyadenosine adducts. These same results were obtained with heat or base-denatured calf thymus DNA. The ratio of diastereomeric adducts with deoxyguanosine from the single-stranded (denatured) calf thymus DNA was approximately 1:1, and the proportion of deoxyadenosine adducts was 40% as compared to ca. 8% in the double-stranded polydeoxynucleotide.

Figure 6 represents an HPLC elution profile of the products obtained by reacting (+) anti-diol epoxide with the deoxytrinucleotide

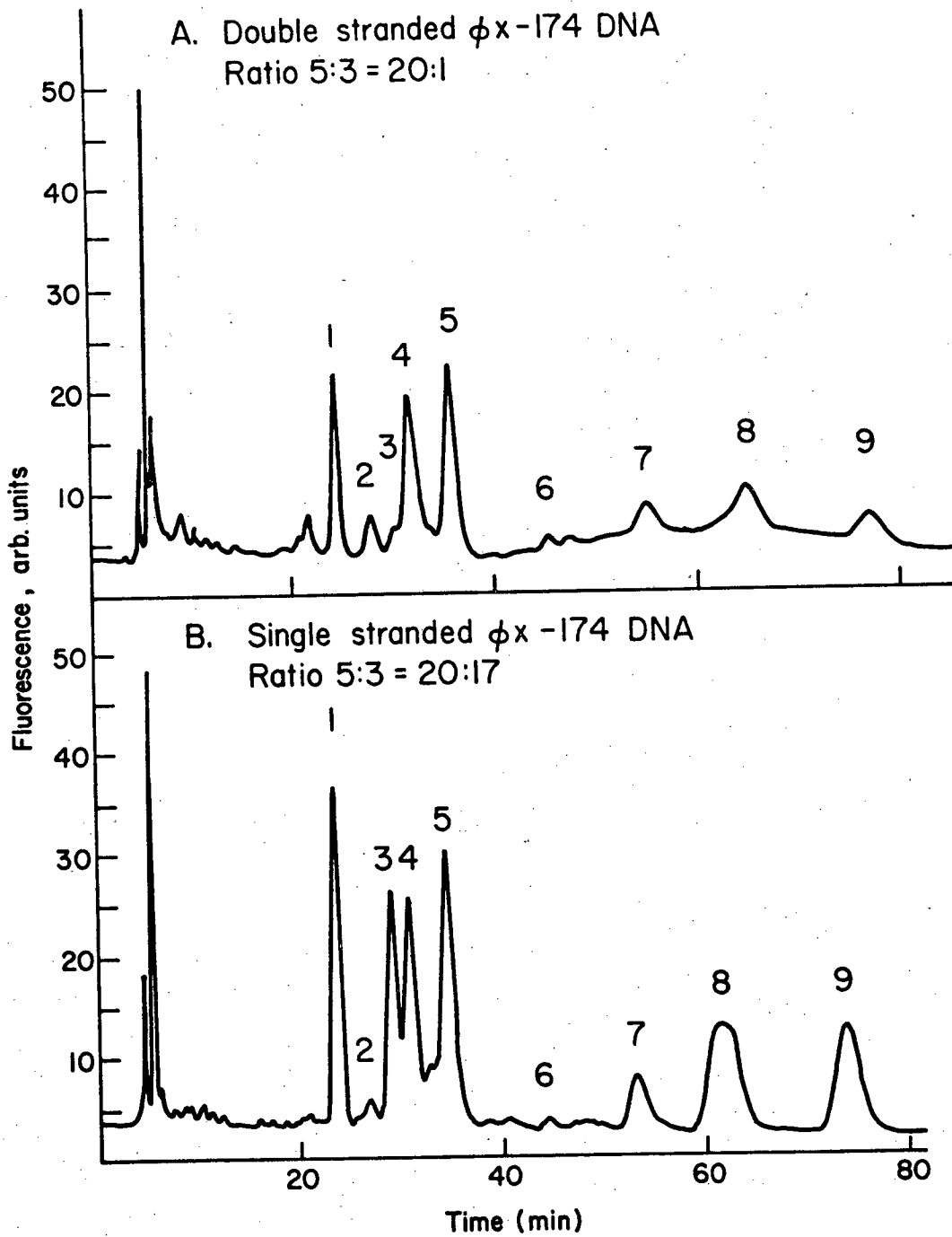
Figure 5

XBL 786-4043

d(CGC). The two diastereomeric trans-N² addition products with deoxyguanosine are formed in a 1:1 ratio. The two stereoisomeric tetraol hydrolysis products (corresponding to peaks 1 and 4 in figure 2) are larger than normal because the ethanol precipitation step used in removing the last traces of non-covalently bound material was omitted (d(CGC) is ethanol-soluble). Preferential binding of one enantiomer thus appears to require at least a double-helical structure.

These results demonstrated that the asymmetrical binding of the two enantiomeric anti-diol epoxides to the exocyclic amino group of guanine in double-stranded DNA was dependent on the secondary structure of the polymer. One possible mechanism for the ability of DNA secondary structure to discriminate between enantiomeric molecules is by stereoselective physical interactions (possibly intercalation) prior to covalent binding. Intercalation or some other physical interaction may readily occur with the (+) enantiomer but not with the mirror image hydrocarbon. Alternatively, the noncovalent interactions could "fix" the hydrocarbon so that only one configuration is in a favorable position to react with the exocyclic amino group of guanine. The following observations suggest that intercalation or some physical association between the BaP-diol epoxide and DNA takes place before covalent binding: (1) as with intercalation of BaP¹⁴⁹ or Actinomycin¹⁵⁰ into DNA, binding of the diol epoxide occurs with a preference for guanine sites, and (2) reaction with denatured DNA "randomizes" adduct formation (loss of stereoselectivity and increased adenine binding). We propose such an intercalation model to account for the stereoselective interaction between BaP-anti-diol epoxide and DNA.

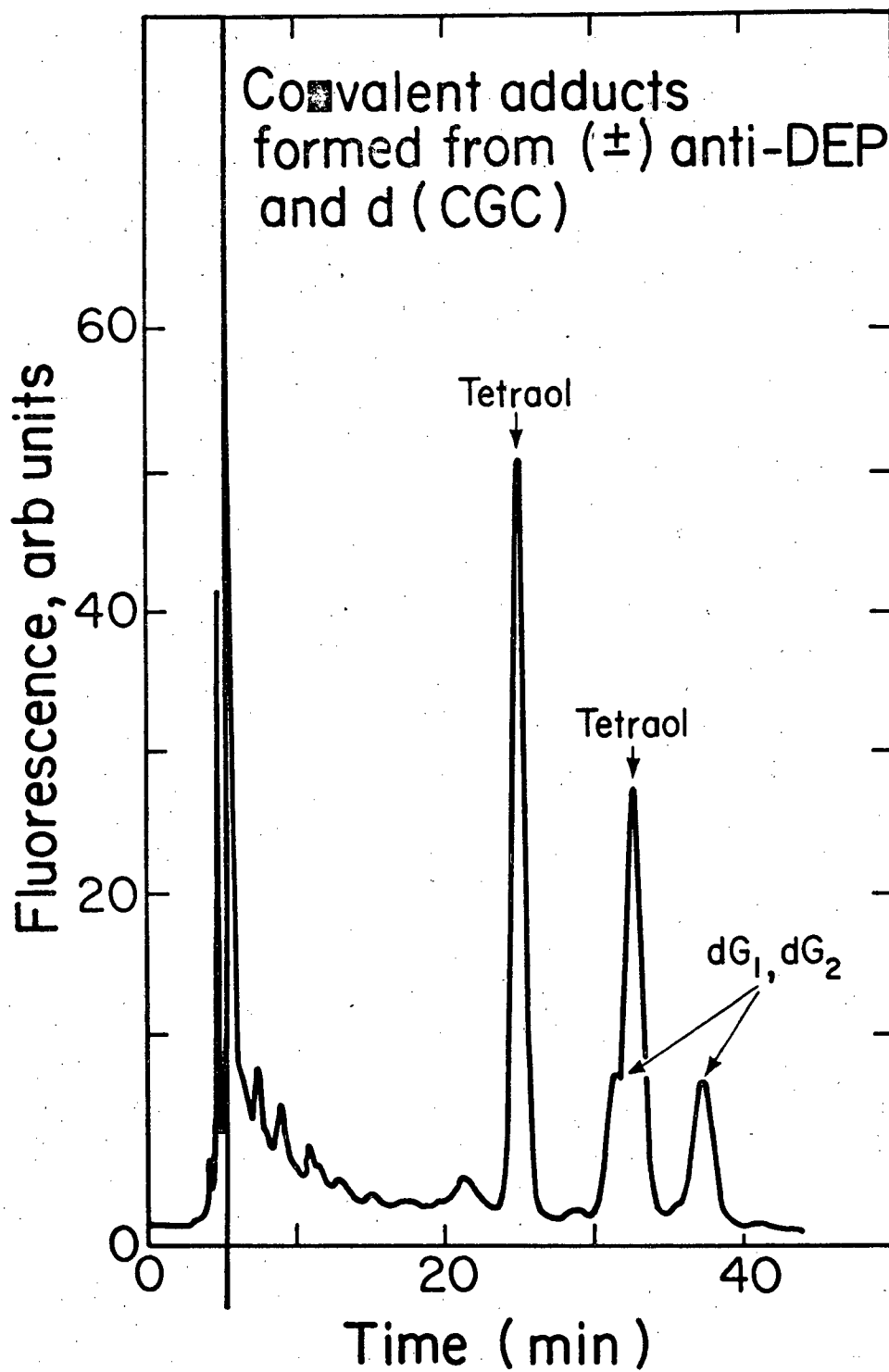

Figure 6

XBL788-4178

The lack of any stereoselectivity in the covalent binding to adenine with either double or single-stranded DNA suggests that the reaction mechanism may be different from that of guanine binding. In the case of adenine binding, the diol epoxide may react without any noncovalent interactions modulating the ratio of diastereomers that is produced.

A correlation between DNA binding and tumorogenic or mutagenic activity has been reported for a series of polycyclic aromatic hydrocarbons, as discussed in chapter 1. Wood *et al.*¹⁵¹ have determined the differences in mutagenic activities of the (+) and (-) anti-diol epoxides using a mammalian cell line and two bacterial tester strains. The differences in mutagenic activity between the (+) and (-) enantiomers in the mammalian cell line was of the same order as we found for the difference in the level of covalent binding to the N²-guanine site in native DNA. In addition, Buening *et al.* have reported on the results of carcinogenicity testing of the enantiomeric anti and syn-diol epoxides in newborn mice.¹⁵² Of the four isomers ((+) and (-)syn-diol epoxide, (+) and (-)anti-diol epoxide), the (+) anti configuration is the most effective at inducing pulmonary tumors, by a factor of greater than ten. Although many compounds induce pulmonary tumors in mice^{153,154}, the (+)anti-diol epoxide appears to be the most potent compound ever tested for the induction of pulmonary tumors. Therefore, the extent of non-enzymatic, covalent binding of the (+)anti enantiomer to double-stranded DNA correlates with both mutagenic and tumorogenic activities. These results suggest that, in addition to metabolic factors, chemical and physical interactions with DNA may be important in evaluating the biological potency

of aromatic hydrocarbons. The regulation of gene expression usually involves specific protein-DNA interactions.¹⁵⁵ The results discussed here demonstrate the occurrence of highly selective binding between small organic molecules and DNA, and the possibility exists that this type of interaction may also have a regulatory role in the normal functioning cell.

One aspect of this problem that has not been addressed here is the difference in binding of diol epoxides to native DNA vs. chromatin, or protein-packaged DNA. Indirect in vivo experiments on the binding of benzo(a)pyrene to DNA in mouse epidermal cells have demonstrated that the major adduct is apparently the (+)anti-diol epoxide N²-deoxyguanosine adduct, however.¹⁴⁶ The role of covalent binding to protein in expressing the biological effects of exposure to activated carcinogens remains an unknown factor. Another complicating issue is the possible existence of stereoselective detoxifying enzymes; for example, the (+)syn and (-)anti- diol epoxide enantiomers may be selectively destroyed in vivo by an as yet uncharacterized conjugating enzyme. Such an enzyme has not yet been discovered, despite an intensive search. In contrast, Conney and co-workers have demonstrated that epoxide hydrase (the normal epoxide detoxifying enzyme) does not bind either the syn or anti-diol epoxides.¹⁵⁶

Experimental

DNA Modification and Isolation of Adducts. ³H-labelled racemic (+)anti-diol epoxide or the resolved enantiomers were incubated with deproteinized calf thymus DNA at an initial concentration of 1 diol epoxide per 250 base pairs in 0.01 M sodium phosphate, pH 7.5, for 1 hour at 37°. Non-covalently bound hydrocarbon was removed by ethyl acetate extraction and repeated isopropanol precipitation of the DNA until zero time blanks contained <3% of the tritium of the incubated samples. Routinely, incubated samples resulted in a modified DNA of 1 hydrocarbon per 8000 base pairs. The diol epoxide-treated DNA was then converted to hydrocarbon-deoxynucleosides and deoxynucleosides by treatment with DNAase-II, spleen phosphodiesterase, and alkaline phosphatase as described in chapter 4. The hydrolyzed sample was applied to a Sephadex LH20 column and the free deoxynucleosides and enzymes eluted with water. Diol epoxide-modified nucleosides were quantitatively recovered with methanol and analyzed by HPLC as described in chapter 4.

Double-stranded (replicative) ϕ X 174 DNA and single-stranded (viral) ϕ X 174 DNA were purchased from Bethesda Research, Bethesda, Maryland. SV40 DNA (double-stranded, superhelical) was generously provided by H. Yokota, Laboratory of Chemical Biodynamics, Lawrence Berkeley Laboratory, Berkeley, California. d(CGCG) was a product of Collaborative Research, Waltham, Massachusetts. Deproteinized calf thymus DNA was obtained from Sigma Chemical Co., St. Louis, Missouri. Denatured DNA's were prepared by heating a solution of DNA above the T_m and then quenching in ice water.

Resolution of anti-Diol Epoxide Enantiomers. Resolution of

the diol epoxide enantiomers was accomplished by resolving (+)r-7,t-8-dihydroxy-7,8-dihydrobenzo(a)pyrene by the method of Yang *et al.*¹⁴¹, and subsequent conversion of each enantiomeric diol to the corresponding anti-diol epoxide.

1. l-Menthoxycetic acid was prepared from (-) menthol according to the procedure of Leffler and Calkins.¹⁵⁷
2. (-)- Menthoxyacetyl chloride:¹⁵⁸ 16 g of l-menthoxyacetic acid was placed in a 50 mL addition funnel, connected to a 100 mL flask containing 26 mL of thionyl chloride. The acid was added dropwise over a period of 20 minutes, and this mixture heated at 100° for 17 hours. Excess thionyl chloride was then removed by distillation, and the (-) menthoxyacetyl chloride distilled in vacuo (117-120°/ 3 mm). $[\alpha]_D^{25} = -89^\circ$ (lit. -89.6°).¹⁵⁸
3. trans-Dimethoxyacetates of (+)r-7,t-8-dihydroxy-7,8-dihydrobenzo(a)pyrene: were prepared by dissolving 310 mg of the (+)7,8-diol in 5 mL of dry pyridine plus 1 mL of (-) menthoxyacetyl chloride. The mixture was stirred for 20 hours, and then precipitated by the addition of ethyl ether. This material was dissolved in chloroform and washed with dilute HCl, dilute NaOH, and water. The solution was dried over K_2CO_3 and concentrated to a minimum volume. MS: M^+ at m/z 678; also m/z 464(280), 268(1000), 252(510), and 239(490).

The diastereomeric menthoxyacetates were separated by semi-preparative HPLC using 10 μ silica gel (either 2.1 mm x 50 cm or 9.2 mm x 50 cm), eluted with dichloromethane- n-hexane. Figure 7 represents an HPLC trace, demonstrating that separation of the two diastereomeric dimethoxyacetates could be achieved. The separated

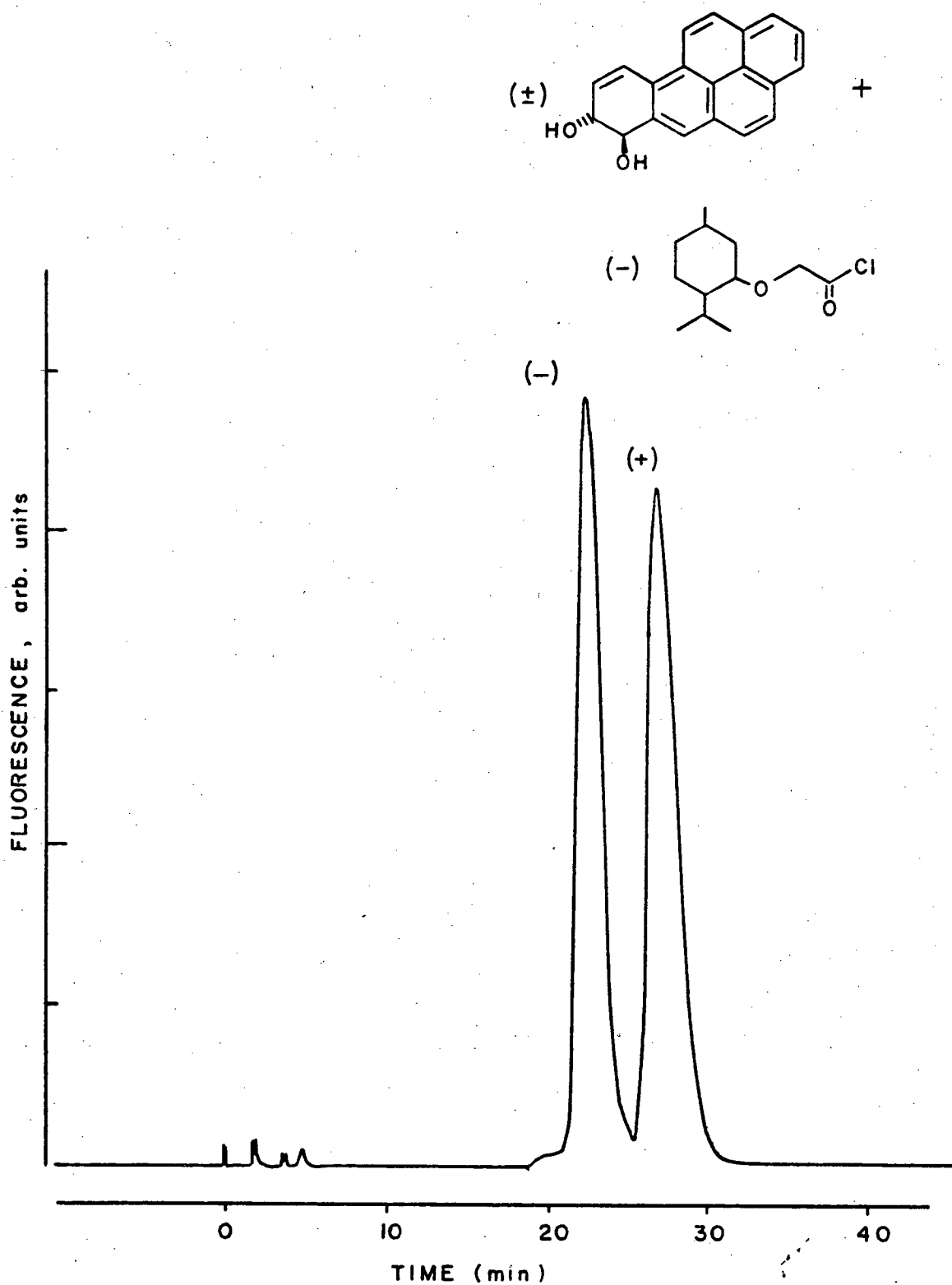

Figure 7: Resolution of 7,8-diol enantiomers

menthoxyacetates (ca. 10 mg of each) were then dissolved in 10 mL of THF plus 1 mL of methanol containing 10 mg of sodium methoxide. After 10 minutes at 60° the reaction mixture was extracted with 30 mL of ethyl ether plus 40 mL water. The ether solution was washed with water, dried over K_2CO_3 , and concentrated to a minimum volume. The crude enantiomeric diols were then purified by semi-preparative HPLC on a Whatman 9.1 mm x 50 cm C_{18} column (octadecylsilane, based on 10 μ silica gel), eluted with methanol-water. The isolated (+) and (-) trans-r-7,t-8-dihydroxy-7,8-dihydrobenzo(a)pyrenes were approximately 96% optically pure. Both enantiomers had identical mass spectra, and co-chromatographed with authentic racemic (+) trans-7,8-diol.

$[\alpha]_D^{25}$ (-)enantiomer = -430° (lit. -432°); $[\alpha]_D^{25}$ (+)enantiomer = +420° (lit. +424°). Optical rotations and circular dichroism spectra were recorded on a non-commercial instrument.¹⁵⁹

4. anti-Diol Epoxide Enantiomers ((+) and (-) r-7,t-8-Dihydroxy-t-9, 10-oxy-7,8,9,10-tetrahydrobenzo(a)pyrene):¹⁴⁴ Each enantiomeric diol was dissolved in 6 mL of THF containing 1.1 molar equivalents of 100% m-chloroperbenzoic acid. Progress of the oxidation was monitored by observing the UV-absorption spectrum (disappearance of the 368 nm band and appearance of the 344 nm band). 20 mL of ethyl ether was added, and the reaction mixture washed successively with sodium sulfite, sodium bicarbonate, and water. After drying over K_2CO_3 , the resolved enantiomers were redissolved in THF and the optical rotation measured: (+): +70° (lit. +72°); (-): -63° (lit. -68°).^{142,144} MS: (di-TMS ether) identical to racemic (+) anti-diol epoxide (compound XXIV). The THF was then evaporated and the diol epoxide enantiomers stored as a solution in dry DMSO at -70°. Yang et al.¹⁴² and Jerina et al.¹⁴⁴

have determined the absolute configuration of the trans-7,8-diol (and therefore of the anti-diol epoxides) via the exciton chirality method: (+)anti-diol epoxide is (7R,8S,9R,10R) and (-)anti-diol epoxide is (7S,8R,9S,10S).

Chapter 6: Conclusions

It is clear that our understanding of chemical carcinogenesis has undergone a conceptual revolution over the past ten years. Metabolic activation is now understood to be the key event that determines the biological activity of a vast number of different types of chemical structures. The susceptibility of a given tissue to a chemical carcinogen is determined by a number of factors, including transport, enzymatic activation and detoxification, and the presence or absence of repair systems that can respond to any damage inflicted by the chemical. Both the chemical reactivity of the proximate or ultimate form of the carcinogen and the possible responses of the biological system to the carcinogen must be understood in detail in order to predict the effects of exposure on the integrity of the cell.

The high mutagenic and carcinogenic activity of 7R,8S-dihydroxy-9R,10R-epoxy-7,8,9,10-tetrahydrobenzo(a)pyrene (+ -anti-diol epoxide) appears to be due to a unique combination of chemical reactivity and immunity against detoxification by cellular enzymes. When arene oxides were first implicated in the biological activity of polycyclic aromatic hydrocarbons, there was a bias on the part of investigators to stress the chemical reactivity of possible metabolites. For example, various K-region epoxides were synthesized and shown to be both mutagenic and capable of initiating cell transformation in vitro.¹⁶⁰ It is now believed that these K-region oxides are not involved in either mutagenesis or cell transformation in most mammalian systems because of the existence of efficient detoxification pathways such as epoxide hydrase or glutathione-S-epoxide transferase.⁶² When attempting

to evaluate the reactivity of a potential "ultimate" carcinogen, the possible existence of enzymatic detoxification schemes must also be considered. Chemical reactivity per se is not indicative of biological activity.

The best evidence to date indicates that the anti- and syn- diol epoxides are formed in a ratio of about 9:1 in vivo.^{139,146} Both are formed metabolically with high optical purity, as the (+) anti and (-) syn enantiomers. In a purely chemical sense there is not a great deal of difference between them. When the diol epoxides were first proposed as possible metabolites of benzo(a)pyrene, a great deal of theorizing about the differences between the two isomers found its way into the literature. Both Hulbert¹⁶¹ and Jerina⁹⁸ postulated that the syn isomer should be more reactive chemically, and therefore more reactive biologically. This idea was based on the hypothesis that transannular hydrogen bonding between the oxide ring and the 7-hydroxyl group in the syn isomer would lead to anchimeric assistance of attack at C-10 by target nucleophiles. Initial kinetic and conformational (¹H-NMR) studies supported this hypothesis: the syn isomer was observed to be more reactive than the anti isomer with thiolate anion⁹⁸, and the half-life for hydrolysis of the syn isomer in aqueous buffers was noticeably shorter than that of anti-diol epoxide. Data from biological systems has been more difficult to interpret. Initial studies with bacterial mutagenesis systems showed the syn isomer to be more active than the anti isomer.¹⁶² Mutagenesis systems based on eukaryotic cell lines, however, show the reverse: (+) anti-diol epoxide was a more efficient mutagen than the syn isomer in Chinese hamster V79 cells (assaying for the presence of HGPRT enzyme via resistance to

8-azaguanine).^{163,164} Inhibition of infectivity of QB RNA phage has also been found to be more effective with the anti-diol epoxide than with the syn isomer.¹⁶⁵ Kinetic studies have shown that the syn-diol epoxide is not detoxified by hydrolysis at a sufficiently greater rate than the anti isomer to account for these differences in biological activity.¹¹⁵ The (+) anti-diol epoxide enantiomer is clearly the most active (more than ten times as active as either syn enantiomer) compound of all known benzo(a)pyrene metabolites in inducing pulmonary tumors.¹⁵² This observation, along with the fact that it is formed to a much greater extent than is the syn isomer, justifies the decision to concentrate research efforts on it. The (+) anti-diol epoxide is now considered to be the prototype "ultimate carcinogen", and a great deal of research effort is being devoted to studying the effects of this chemical on biological systems.

Generality of the Diol Epoxide Pathway:

Jerina has attempted to generalize what is known about benzo(a)-pyrene activation to explain the biological activity of other polycyclic aromatic hydrocarbons.¹⁶⁶ This has been termed the "bay region" theory, and proposes that the carcinogenicity of PAH's results from metabolic formation of reactive benzo-ring diol epoxides in which the epoxide ring is situated near the "bay" region (*ie.*, the 1,2 bond of a phenanthrene-type ring system) of the hydrocarbon:

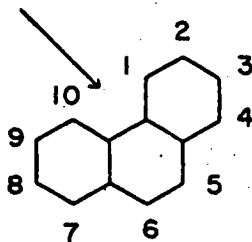

The generality of this concept is now being tested by a number of researchers; there is good evidence that both substituted benzo(a)anthracenes¹⁶⁷ and 3-methylcholanthrene¹⁶⁸ are activated via such diol epoxide-type structures:

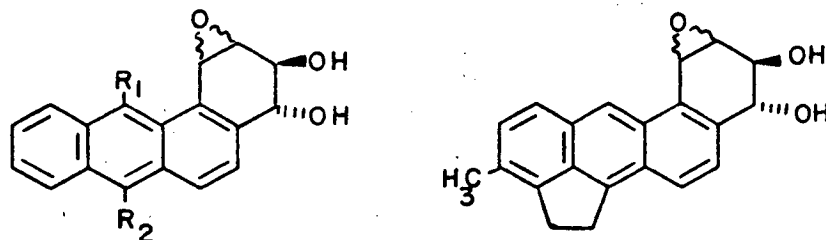

It is not clear that any real conceptual breakthrough is attained by gathering these observations into a generalized "bay region" theory, however. The key events are still metabolic activation and covalent binding to informational macromolecules, as first hypothesized by the Miller's in the 1960's.²³ The reactivity of the benzo(a)pyrene diol epoxides is readily explained by the high stability afforded a carbonium ion at the benzylic C-10 position via interaction with the pyrene aromatic system:

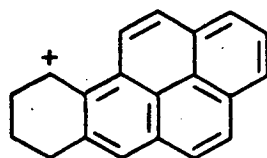

Molecular orbital calculations support this idea; they also predict that an epoxide at the 7,8-position should be relatively unreactive.¹⁵⁶ Simple HMO calculations predict that the 6a position of the tetrahydro-

benzo(a)pyrene system corresponds to a nodal plane in the highest occupied molecular orbital for pyrene, resulting in no net stabilization for a carbocation at C-7:

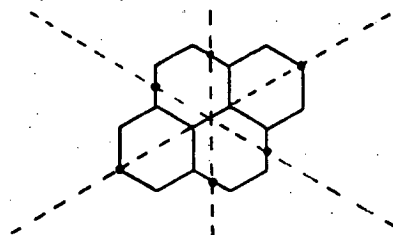
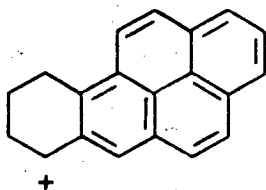

Thus 7,8-epoxy-7,8,9,10-tetrahydrobenzo(a)pyrene and the corresponding 9,10-dihydroxy-7,8-epoxy-7,8,9,10-tetrahydrobenzo(a)pyrene isomers are chemically unreactive (compared to the 7,8-dihydroxy-9,10-epoxides) as well as biologically inactive.^{156,169} The dihydroxyl functionality in the syn and anti-diol epoxides is not required for reactivity, as was demonstrated by the fact that 9,10-epoxy-7,8,9,10-tetrahydrobenzo(a)pyrene is a potent mutagen.¹⁵⁶ The trans-diols do, however, influence solubility and non-covalent interactions with macromolecules, and are probably important in modulating the effects of the compound in vivo. It is clear that many other types of structures besides diol epoxides can be mutagenic or carcinogenic, however. There is some evidence that 9-hydroxybenzo(a)pyrene can be metabolized to a 9-hydroxy-4,5-epoxy-4,5-dihydrobenzo(a)pyrene structure that is both mutagenic and capable of binding to DNA in vitro¹⁷⁰; many K-region oxides are mutagenic and capable of inducing in vitro cell transformation when epoxide hydrolase is inactivated with inhibitors such as 1,1,1-trichloropropylene oxide.^{171,172}

The most general (and probably most useful) conceptual framework

for predicting the activity of a chemical carcinogen is that, depending on the mix of activating and detoxifying enzymes present, a number of electrophilic alkylating species can be formed. If one of these metabolites has the proper reactivity (ie., reactive enough to be an efficient alkylating agent, but not so reactive that it solvolyzes instantly), then it probably will be cytotoxic, mutagenic, and possible tumorigenic. Bruice¹⁷³ and others¹⁷⁴ have attempted to define those structural features of epoxides that determine the proper chemical reactivity for biological activity to be present, but the actual activity of any hypothetical structure can always be modulated by the presence of an appropriate hydrating or conjugating enzyme.

The extreme complexity of enzymatic activation and detoxification cannot be overemphasized. M.J. Coon et al. and Lu et al. have been able to demonstrate that rabbit liver P-448 mono-oxygenase actually consists of at least seven different isoenzymes, each with a different preference for epoxidation at a particular site on benzo(a)pyrene.^{175,176} Thus some isoenzymes preferentially epoxidize the K-region, while others are more efficient at secondary metabolism (ie., diol → diol epoxide). The isoenzymes are also inducible to different extents by different inducers, and the number and type of possible isoenzymes appears to be under complex genetic control.¹⁷⁷ Given the perversity of nature, one can assume that the same situation will hold for other hydrolyzing and conjugating enzymes, resulting in an almost infinite number of possible responses by a given cell when challenged by a pre-carcinogen. This situation is further complicated by factors that will not be discussed here, such as DNA repair¹⁷⁸, promotion¹⁷⁹, and co-carcinogenesis.¹⁸⁰

The causal relationship between covalent binding to macromolecules and cell transformation can best be described as a total unknown. The mutational model of carcinogenesis is appealing because of its simplicity, and because of the very good correlation one finds between biological activity and covalent interactions with DNA by activated chemical carcinogens. The specific nature of the mutational event(s) that leads to loss of growth control is at this point not understood. (Indeed, the details of cellular growth control are so poorly understood that we do not know exactly what questions to ask) The binding of a molecule such as (+) anti-diol epoxide to DNA would be expected to have drastic effects on structure and function. Stable, covalent adducts such as the N²-guanine or N⁶-adenine structures will at the minimum cause local disruption in helix stability (leading to denaturation or "loopouts") and interfere with gene expression and replication.^{181,182} In addition to covalent adducts, (+)anti-diol epoxide can also cause single-strand breaks in DNA either by reacting with the phosphate groups or by a depurination mechanism with consequent formation of alkali-labile sites.¹⁸³ Given the large number of different types of DNA-carcinogen adducts that have been reported to date, it is likely that a multiplicity of sites is involved in the biological activities of chemical carcinogens. The relative frequencies of simple mutational events and events that lead to cell transformation are not known at this time, although the development of combined mutation/transformation assays should provide answers to this question.³⁵ It is safe to state that we are a long way from understanding in any kind of detail the molecular events in a cell that lead to loss of growth

control. Nevertheless, the somewhat remarkable correlation between biological activity and DNA-binding for the (+)anti-diol epoxide and its isomers must have some biochemical basis. Future research on chemical carcinogenesis must now concentrate on the functional consequences of the covalent interactions between molecules such as (+)anti-diol epoxide and nucleic acids.

Perhaps the most significant impact that research on chemical carcinogenesis has had is in the development of cheap, rapid assays for carcinogens. By using a cell extract containing the necessary activating and detoxifying enzymes, it is not necessary to know the exact structures or metabolic pathways involved before one can ask whether or not a potential metabolite of a compound is mutagenic or tumorigenic; one can use the undefined enzyme cocktail and monitor the formation of mutagens with the appropriate tester cells. Cairns has noted that the development of these mutagenesis and transformation assays seems to be the first practical application of molecular biology to human affairs.¹⁸⁴

References

1. R. A. M. Case, M. E. Hosker, D. B. McDonald, and J. T. Pearson, Brit. J. Ind. Med. 11, 75-104 (1954).
2. G. N. Wogan in "Liver Cell Cancer," eds. H. M. Cameron, D. A. Linsell, and G. P. Warwick (Elsevier/North Holland Biomedical Press: New York, 1976), pp. 121-151.
3. Brit. Med. J., Editorial 1, 590-591 (1974).
4. W. G. Figuero, R. Raszkowski, and W. Weiss, New Engl. J. Med. 288, 1096-1097 (1973).
5. Chem. Eng. News 54, 39 (1975).
6. W. Haenszel and M. Kurihara, J. Natl. Cancer Inst. 40, 43-68 (1968).
7. R. Doll and I. Vodopija, "Host-Environmental Interactions in the Etiology of Cancer in Man," in IARC Scientific Publication No. 7, Lyon (1973).
8. J. Higginson in "Environment and Cancer," 24th Symposium Fundam. Cancer Res. (Williams and Wilkins: Baltimore, 1972), pp. 69-92.
9. C. Heidelberger, Ann. Rev. Biochem. 44, 79-121 (1975).
10. P. Pott, "Chirurgical Observations," reprinted in Natl. Cancer Inst. Monogr. 10, 7 (1963).
11. J. W. Cook, C. L. Hewett, and I. Hieger, J. Chem. Soc. 395-405 (1933).
12. J. G. Chalmers, Biochem. J. 28, 1214-1220 (1934).
13. I. Berenblum and R. Schoental, Biochem. J. 36, 92-99 (1942).
14. J. C. Arcos and M. F. Argus, in "Chemical Induction of Cancer," Vol. IIa (Academic Press: New York, 1974), pp. 144-150.
15. E. C. Miller, Cancer Res. 11, 100-108 (1951).

16. W. G. Wiest and C. Heidelberger, Cancer Res. 13, 250-254 (1953).
17. C. Heidelberger and M. G. Moldenhauer, Cancer Res. 16, 442-449 (1956).
18. P. Brookes and P. D. Lawley, Nature 202, 781-784 (1964).
19. P. Brookes, Cancer Res. 26, 1994-2003 (1966).
20. L. M. Goshman and C. Heidelberger, Cancer Res. 27, 1678-1688 (1967).
21. T. Kuroki and C. Heidelberger, Cancer Res. 31, 2168-2176 (1971).
22. E. C. Miller and J. A. Miller, Pharmacol. Rev. 18, 806-838 (1966).
23. J. A. Miller, Cancer Res. 30, 559-576 (1970).
24. E. Miller and J. A. Miller, in "Molecular Biology of Cancer," ed. H. Busch (Academic Press: New York, 1974), pp. 377-402.
25. E. Boyland and P. Sims, Biochem. J. 91, 493-506 (1964).
26. E. Boyland, Biochem. Soc. Symp. 5, 40 (1950).
27. G. Guroff, J. W. Daly, D. M. Jerina, J. Renson, B. Witkop, and S. Udenfriend, Science 157, 1524-1530 (1967).
28. D. M. Jerina and J. W. Daly, Science 185, 573-582 (1974).
29. D. M. Jerina, J. W. Daly, B. Witkop, P. Zaltman-Nirenberg, and S. Udenfriend, Biochemistry 9, 147-155 (1970).
30. J. W. Daly, D. M. Jerina, and B. Witkop, Experientia 28, 1129-1149 (1972).
31. J. R. Gillette, D. C. Davis, and H. Sesame, Ann. Rev. Pharmacol. 12, 47-80 (1972).
32. M. J. Coon and A. Y. H. Lu, in "Microsomes and Drug Oxidations," eds. J. R. Gillette, A. H. Conney, G. J. Cosmides, R. W. Estabrook, J. R. Fouts and G. J. Mannering (Academic Press: New York, 1969), pp. 151-166.

33. R. W. Estabrook and J. Werringloer, in "Drug Metabolism Concepts," ed. D. M. Jerina (American Chemical Society: Washington, D.C., 1977), pp. 1-26.
34. A. Y. H. Lu, D. Ryan, D. M. Jerina, J. W. Daly, and W. Levin, J. Biol. Chem. 250, 8283-8288 (1975).
35. N. Nemoto and H. V. Gelboin, Biochem. Pharmacol. 25, 1221-1226 (1976).
36. G. M. Cohen, B. P. Moore, and J. W. Bridges, Biochem. Pharmacol. 26, 551-553 (1977).
37. C. Irving, Methods Cancer Res. 7, 190-244 (1973).
38. D. O. Tofft and T. C. Spelsberg, J. Natl. Cancer Inst. 52, 1351-1354 (1974).
39. B. N. Ames, W. E. Durston, E. Yamasaki and F. D. Lee, Proc. Natl. Acad. Sci. USA 70, 2281-2285 (1973).
40. E. Y. H. Chu and M. V. Malling, Proc. Natl. Acad. Sci. USA 61, 1306-1312 (1968).
41. H. V. Gelboin, Cancer Res. 29, 1272-1276 (1969).
42. P. L. Grover and P. Sims, Biochem J. 110, 159-160 (1969).
43. C. Pietropaolo and I. B. Weinstein, Cancer Res. 35, 2191-2198 (1975).
44. T. Meehan, D. Warshawsky, and M. Calvin, Proc. Natl. Acad. Sci. USA 73, 1117-1120 (1976).
45. C. Nagata, M. Kodama, and Y. Tageshira, GANN 58, 493-504 (1967).
46. S. A. Lesko, H. D. Hoffman, P.O.P. Ts'o, and V. Maher, Progr. Mol. Subcell Biol. 2, 347-370 (1971).
47. P. Daudel, M. Duquesne, P. Vigney, P. L. Grover, and P. Sims, FEBS Lett. 57, 250-253 (1975).

48. B. Ivanovic, N. E. Geacintov, and I. B. Weinstein, Biochem. Biophys. Res. Commun. 70, 1172-1174 (1976).
49. M. J. S. Dewar and N. Trinajstic, Coll. Czech. Chem. Commun. 35, 3136-3189 (1970).
50. G. Holder, H. Yagi, P. Dansette, D. M. Jerina, W. Levin, A. Y. H. Lu, and A. H. Conney, Proc. Natl. Acad. Sci. USA 71, 4356-4360 (1974).
51. J. K. Selkirk, R. G. Croy, P. P. Roller, and H. V. Gelboin, Cancer Res. 34, 3474-3480 (1974).
52. G. M. Holder, H. Yagi, D. M. Jerina, W. Levin, A. Y. H. Lu, and A. H. Conney, Arch. Biochem. Biophys. 170, 557-566 (1975).
53. J. K. Selkirk, R. G. Croy, J. P. Whitlock, and H. V. Gelboin, Cancer Res. 35, 3651-3655 (1975).
54. H. E. Seifried, D. J. Birkett, W. Levin, A. Y. H. Lu, A. H. Conney, and D. M. Jerina, Arch. Biochem. Biophys. 178, 256-263 (1977).
55. C. H. Fox, J. K. Selkirk, F. M. Price, R. G. Croy, K. K. Sanford, and M. Cottler-Fox, Cancer Res. 35, 117-123 (1975).
56. T. A. Fjellstedt, R. H. Allen, B. K. Duncan, and W. B. Jakoby, J. Biol. Chem. 248, 3702-3707 (1973).
57. H. L. Falk, P. Kotin, S. S. Lee, and A. Nathan, J. Natl. Cancer Inst. 28, 699-723 (1962).
58. A. W. Wood, R. L. Goode, R. L. Chang, W. Levin, A. H. Conney, H. Yagi, P. M. Dansette, and D. M. Jerina, Proc. Natl. Acad. Sci. USA 72, 3176-3180 (1975).
59. P. Sims and P. L. Grover, Adv. Cancer Res. 20, 165-190 (1974).

60. W. M. Baird, R. G. Harvey, and P. Brookes, Cancer Res. 35, 54-57 (1975).
61. A. Borgen, H. Darvey, N. Castagnoli, T. T. Crocker, R. E. Rasmussen, and I. Y. Wang, J. Med. Chem. 16, 502-506 (1973).
62. A. W. Wood, W. Levin, A. Y. H. Lu, H. Yagi, O. Hernandez, D. M. Jerina, and A. H. Conney, J. Biol. Chem. 251, 4882-4890 (1976).
63. P. Sims, P. L. Grover, A. Swaisland, K. Pal, and A. Hower, Nature 252, 326-328 (1974).
64. E. Clar, in "Polycyclic Hydrocarbons," Vols. I and II (Academic Press: New York, 1964).
65. P. Sims, J. Chem. Soc. C, 34-36 (1968).
66. L. F. Fieser and F. C. Novello, J. Amer. Chem. Soc. 62, 1855-1859 (1940).
67. Huang-Minlon, J. Amer. Chem. Soc. 68, 2487-2488 (1946).
68. G. A. R. Kon and E. M. Roe, J. Chem. Soc., 143-146 (1945).
69. J. Waterfall and P. Sims, Biochem. J. 128, 265-277 (1972).
70. J. S. Baran, J. Org. Chem. 25, 247 (1960).
71. J. D. Albright and L. Goldman, J. Amer. Chem. Soc. 89, 2416-2423 (1967).
72. W. K. Anderson and T. Veysoghu, J. Org. Chem. 38, 2267-2268 (1973).
73. J. W. Cook and R. Schoental, J. Chem. Soc. 170-176 (1948).
74. R. G. Harvey, S. H. Goh, and C. Cortez, J. Amer. Chem. Soc. 97, 3468-3479 (1975).
75. H. Vollmann, H. Becker, M. Corell and H. Streck, Ann. 531, 1-158 (1937).
76. H. E. Schroeder, F. B. Stilmar, and F. S. Palmer, J. Amer. Chem. Soc. 96, 446-450 (1956).

77. D. J. McCaustland, D. L. Fischer, K. C. Kolwyck, W. P. Duncan, J. C. Wiley, C. S. Menon, J. F. Engel, J. K. Selkirk, and P. P. Roller, in "Carcinogenesis, Vol. I; Polynuclear Aromatic Hydrocarbons: Chemistry, Metabolism, and Carcinogenesis," eds. R. I. Freudenthal and P. W. Jones (Raven: New York, 1976), pp. 349-411.
78. J. C. Arcos and M. F. Argus, in "Chemical Induction of Cancer," Vol. IIa (Academic Press: New York, 1974), pp. 184-235.
79. P. S. Bailey and R. E. Erickson, Org. Syn. 41, 41-45 (1961).
80. T. C. Bruice and P. Y. Bruice, Acc. Chem. Res. 9, 378-384 (1976).
81. V. Mark, J. Amer. Chem. Soc. 85, 1884-1885 (1963).
82. M. S. Newman and S. Blum, J. Amer. Chem. Soc. 86, 5598-5600 (1964).
83. J. K. Stille and R. T. Foster, J. Org. Chem. 28, 2703-2707 (1963).
84. A. Streitwieser, Jr. and J. I. Brauman, "Supplemental Tables of Molecular Orbital Calculations," Vols. I and II (Pergamon Press: Oxford, 1965).
85. R. M. Jerina, H. Yagi, and J. W. Daly, Heterocycles 1, 267-293 (1975).
86. S. H. Goh and R. G. Harvey, J. Amer. Chem. Soc. 95, 242-243 (1973).
87. P. Dansette and D. M. Jerina, J. Amer. Chem. Soc. 96, 1224-1225 (1974).
88. H. Yagi, P. Dansette, and D. M. Jerina, J. Lab. Comp. and Radiopharm. 12, 127-132 (1976).
89. S. Krishnan, D. G. Kuhn, G. A. Hamilton, J. Amer. Chem. Soc. 99, 8121-8123 (1977).
90. W. Lijinski and J. Zechmeister, J. Amer. Chem. Soc. 75, 5495-5497 (1953).
91. E. Vogel and F. G. Klärner, Angew Chem. Int. Ed. Engl. 7, 374-375

(1968).

92. H. Yagi and D. M. Jerina, J. Amer. Chem. Soc. 95, 243-244 (1973).
93. R. G. Harvey, S. H. Goh, and C. Cortez, J. Amer. Chem. Soc. 97, 3468-3479 (1975).
94. G. Berti, B. Macchia, and F. Macchia, Tet. Lett. 38, 3421-3427 (1965).
95. G. E. McCasland and E. Horswill, J. Amer. Chem. Soc. 76, 1654-1658 (1954).
96. P. Chamberlain, M. L. Roberts, and G. H. Whitham, J. Chem. Soc. B 1374-1381 (1970).
97. H. O. House, in "Modern Synthetic Reactions" (Benjamin: Menlo Park, 1972), pp. 292-321.
98. H. Yagi, O. Hernandez, and D. M. Jerina, J. Amer. Chem. Soc. 97, 6881-6883 (1975).
99. D. J. McCaustland and J. F. Engel, Tet. Lett. 30, 2549-2552 (1975).
100. A. M. Jeffrey, H. J. C. Yeh, D. M. Jerina, T. R. Patel, J. F. Davey, and D. T. Gibson, Biochemistry 14, 575-584 (1975).
101. H. Yagi, D. R. Thakker, O. Hernandez, M. Korreda, and D. M. Jerina, J. Amer. Chem. Soc. 99, 1604-1611 (1977).
102. A. F. Casy, in "PMR Spectroscopy in Medicinal and Biological Chemistry" (Academic Press: New York, 1971), pp. 398-399.
103. F. A. Beland and R. G. Harvey, J. Chem. Soc. Chem. Commun., 84-86 (1976).
104. S. K. Yang, D. W. McCourt, H. V. Gelboin, J. R. Miller, and P. P. Roller, J. Amer. Chem. Soc. 99, 5124-5134 (1977).
105. A. A. Moghissi and M. W. Carter, "Tritium" (Messenger Graphics: Phoenix, Arizona, 1973).

106. D. J. McCaustland, D. L. Fischer, W. P. Duncan, E. J. Ogilvie, and J. F. Engel, J. Lab. Comp. and Radiopharm. 12, 583-589 (1976).
107. H. Yagi, G. M. Holder, P. M. Dansette, O. Hernandez, H. J. C. Yeh, R. A. LeMahieu, and D. M. Jerina, J. Org. Chem. 41, 977-985 (1976).
108. W. S. Johnson, J. D. Bass, and K. L. Williamson, Tetrahedron 19, 861-867 (1963).
109. A. Dipple, P. Brookes, D. S. Mackintosh, and M. P. Rayman, Biochemistry 10, 4323-4330 (1971).
110. F. Pochon and A. Michelson, Eur. J. Biochem. 21, 144-153 (1971).
111. G. B. Petersen and K. Burton, Biochem. J. 92, 666-672 (1964).
112. B. Singer, Nature 264, 333-339 (1976).
113. B. Singer, Progr. Nucl. Acids Res. Molec. Biol. 15, 219-284 330-332 (1975).
114. A. H. Conney, A. Wood, W. Levin, A. Y. H. Lu, R. Chang, P. Wislocki, R. L. Goode, G. M. Holder, P. M. Dansette, H. Yagi, and D. M. Jerina, in Biological Reactive Intermediates: Formation, Toxicity, and Inactivation, eds. D. Jollow, J. J. Kocsis, R. Snyder, and H. Vainio (Plenum: New York, 1977), pp. 335-357.
115. S. K. Yang, D. W. McCourt, and H. V. Gelboin, J. Amer. Chem. Soc. 99, 5130-5134 (1977).
116. C. C. Richardson, R. B. Inman, and A. Kornberg, J. Mol. Biol. 9, 46-69 (1964).
117. K. Biemann in "Mass Spectrometry: Organic Chemical Applications" (McGraw-Hill: New York, 1962), pp. 4-19.
118. A. L. Burlingame, D. H. Smith, T. O. Merren, and R. W. Olsen, "Computers in Analytical Chemistry," in Progress Anal. Chem. Series, Vol. 4, eds. C. H. Orr and J. A. Norris (Plenum: New

- Science 193, 592-595 (1976).
132. M. Koreeda, P. D. Moore, H. Yagi, H. J. Yeh and D. M. Jerina, J. Amer. Chem. Soc. 98, 6720-6721, (1976).
 133. J. N. Davidson, in "The Biochemistry of the Nucleic Acids" (Chapman and Hall: Norfolk, Great Britain, 1972), pp. 183-214.
 134. C. L. Schildkraut, C. C. Richardson, and A. Kornberg, J. Mol. Biol. 9, 24-45 (1964).
 135. M. Axelson and J. Sjövall, J. Steroid Biochem. 5, 733-738 (1974).
 136. E. J. Gabbay and K. Sanford, Bioorg. Chem. 3, 91-102 (1974).
 137. C. H. Yeh, P. P. Fu, F. A. Beland and R. G. Harvey, Bioorg. Chem. 7, 497-506 (1978).
 138. P. D. Moore, M. Koreeda, P. G. Wislocki, W. Levin, A. H. Conney, H. Yagi, and D. M. Jerina, Amer. Chem. Soc. Symp. Ser. 44, 127-154 (1977).
 139. S. K. Yang, D. W. McCourt, P. P. Roller, and H. V. Gelboin, Proc. Natl. Acad. Sci. USA 73, 2594-2597 (1976).
 140. N. Harada and K. Nakanishi, Acc. Chem. Res. 5, 257-263 (1972).
 141. S. K. Yang, H. V. Gelboin, J. D. Weber, V. Sankaran, D. F. Fischer, and J. F. Engel, Anal. Biochem. 78, 520-526 (1977).
 142. S. K. Yang, D. W. McCourt, J. C. Leutz, and H. V. Gelboin, Science 196, 1199-1201 (1977).
 143. K. Nakanishi, H. Kassai, H. Cho, R. G. Harvey, A. M. Jeffrey, K. W. Jennette, and I. B. Weinstein, J. Amer. Chem. Soc. 99, 258-259 (1977).
 144. H. Yagi, H. Akagi, D. R. Thakker, H. D. Mah, M. Koreeda, and D. M. Jerina, J. Amer. Chem. Soc. 99, 2358-2359 (1977).

- York, 1970), pp. 17-38.
119. A. L. Burlingame, R. W. Olsen, and R. McPherron, in Adv. Mass Spectrom., Vol. 6, ed. A. R. West (Applied Science Publishers: Barking, Essex, 1974), pp. 1053-1059.
 120. "Handbook of Derivatives for Chromatography," eds. K. Blau and G. S. King (Heydon & Sons: London, 1977).
 121. D. L. von Minden and J. A. McCloskey, J. Amer. Chem. Soc. 95, 7480-7490 (1973).
 122. S. Hakamori, J. Biochem. (Tokyo) 55, 205-208 (1964).
 123. J. F. Klebe, H. Finkbeiner, and D. M. White, J. Amer. Chem. Soc. 88, 3390-3395 (1966).
 124. H. R. Morris, W. H. Dudley, and R. P. Ambler, Biochem. J. 125, 189-201 (1971).
 125. J. A. McCloskey, in "Basic Principles in Nucleic Acid Chemistry," ed. P. O. P. Ts'o (Academic Press: New York, 1974), pp. 309-311.
 126. J. A. McCloskey, A. M. Lawson, K. Tsuboyama, P. M. Krueger, and R. N. Stillwell, J. Amer. Chem. Soc. 90, 4182-4184 (1968).
 127. J. J. Dolhun and J. L. Wiebers, Org. Mass Spectrom. 3, 669-681 (1970).
 128. H. R. Morris, FEBS Lett. 22, 257-260 (1972).
 129. M. Koreeda, P. D. Moore, P. G. Wislocki, W. Levin, A. H. Conney, H. Yagi, and D. M. Jerina, Science 199, 779-781 (1978).
 130. A. M. Jeffrey, K. W. Jenette, S. H. Blobstein, I. B. Weinstein, F. A. Beland, R. G. Harvey, H. Kasai, I. Miura, and K. Nakanishi, J. Amer. Chem. Soc. 98, 5714-5715 (1976).
 131. I. B. Weinstein, A. M. Jeffrey, K. W. Jenette, S. H. Blobstein, R. G. Harvey, C. Harris, H. Autrup, H. Kasai, and K. Nakanishi,

145. "Recycle Chromatography," Application Note for Waters 6000A Solvent Delivery System, Waters Associates, Milford, MA (1976).
146. E. Bresnick, T. A. Stoming, J. B. Vaught, D. R. Thakker, and D. M. Jerina, Arch. Biochem. Biophys. 183, 31-37 (1977).
147. M. R. Osborne, R. G. Harvey, and P. Brookes, Chem. Biol. Interactions 20, 123-130 (1978).
148. T. Meehan, K. Straub, and M. Calvin, Nature 269, 725-727 (1977).
149. S. A. Lesko, H. D. Hoffman, P. O. P. Ts'o, and V. Maher, in "Progress in Molecular and Subcellular Biology," Vol. 2, ed. F. E. Hahn (Springer-Verlag: Berlin, 1971), pp. 347-370.
150. D. M. Crothers and W. Muller, Eur. J. Biochem. 54, 267-277 (1975).
151. A. W. Wood, R. L. Chang, W. Levin, H. Yagi, D. R. Thakker, D. M. Jerina, and A. H. Conney, Biochem. Biophys. Res. Commun. 77, 1389-1396 (1977).
152. M. K. Buening, P. G. Wislocki, W. Levin, H. Yagi, D. R. Thakker, H. Akagi, M. Koreeda, D. M. Jerina, and A. H. Conney, Proc. Natl. Acad. Sci. USA 75, 5358-5361 (1978).
153. B. Toth, Cancer Res. 28, 727-738 (1968).
154. M. B. Shimkin and G. D. Stoner, Adv. Cancer Res. 21, 1-58 (1975).
155. B. Lewin, "Gene Expression" (Wiley: London, 1974), pp. 320-375.
156. A. W. Wood, P. G. Wislocki, R. L. Chang, W. Levin, A. Y. H. Lu, H. Yagi, O. Hernandez, D. M. Jerina, and A. H. Conney, Cancer Res. 36, 3358-3366 (1976).
157. M. T. Leffler and A. E. Calkins, Org. Syn. Coll. 3, 544-546 (1955).
158. M. T. Leffler and A. E. Calkins, Org. Syn. Coll. 3, 547-548 (1955).
159. J. C. Sutherland, L. E. Vickery, and P. M. Klein, Rev. Sci. Instrum. 45, 1089-1094 (1974).

160. C. Heidelberger, in "Chemical Carcinogenesis," eds. P. O. P. Ts'o and J. A. diPaolo, part B (Dekker: New York, 1974), pp. 457-462.
161. P. B. Hulbert, Nature 256, 146-147 (1975).
162. C. Malaveille, T. Kuroki, P. Sims, P. L. Grover, and H. Bartsch, Mutation Res. 44, 313-320 (1977).
163. E. Huberman, L. Sachs, S. K. Yang, and H. V. Gelboin, Proc. Natl. Acad. Sci. USA 73, 607-610 (1976).
164. R. F. Newbold and P. Brookes, Nature 261, 52-54 (1976).
165. W. T. Hsu, R. G. Harvey, E. J. Lin, and S. B. Weiss, Proc. Natl. Acad. Sci. USA 74, 1378-1382 (1977).
166. D. M. Jerina, R. Lehr, M. Schaefer-Ridder, H. Yagi, J. M. Karle, D. R. Thakker, A. W. Wood, A. Y. H. Lu, D. Ryan, S. West, W. Levin, and A. H. Conney, "Bay Region Epoxides of Dihydrodiols: A Concept Explaining the Mutagenic and Carcinogenic Activity of Benzo[a]-pyrene and Benzo[a]anthracene," in Origins of Human Cancer, Book B, eds. H. H. Hiatt, J. D. Watson, and J. A. Winsten (Cold Spring Harbor Laboratory, 1977), pp. 639-658.
167. M. W. Chou and S. K. Yang, Proc. Natl. Acad. Sci. USA 75, 5466-5470 (1978).
168. D. R. Thakker, W. Levin, A. W. Wood, A. H. Conney, T. A. Stoming, and D. M. Jerina, J. Amer. Chem. Soc. 100, 645-647 (1978).
169. T. Kuroki, in "Polycyclic Hydrocarbons and Cancer," Vol. 2, eds. H. V. Gelboin and P. O. P. Ts'o (Academic Press: New York, 1978), pp. 123-134.
170. O. Pelkonen, A. R. Boubis, H. Yagi, D. M. Jerina, and D. W. Nebert, Mol. Pharmacol. 14, 306-322 (1978).

171. J. K. Selkirk, R. G. Croy, P. P. Roller, and H. V. Gelboin, Cancer Res. 34, 3474-3480 (1974).
172. B. Jernstrom, H. Vadi, and S. Orrenius, Cancer Res. 36, 4107-4113 (1976).
173. A. R. Becker, J. M. Janusz, D. Z. Rogers, and T. C. Bruice, J. Amer. Chem. Soc. 100, 3244-3246 (1978).
174. D. M. Jerina, R. E. Lehr, H. Yagi, O. Hernandez, P. M. Dansette, P. G. Wislocki, A. W. Wood, R. L. Chang, W. Levin, and A. H. Conney, Environ. Health Perspec. (in press, 1979).
175. J. Deutsch, J. C. Leutz, S. K. Yang, H. V. Gelboin, Y. L. Chiang, K. P. Vatsis, and M. J. Coon, Proc. Natl. Acad. Sci. USA 75, 3123-3127 (1978).
176. M. T. Huang, S. B. West, and A. Y. H. Lu, J. Biol. Chem. 251, 4659-4665 (1976).
177. D. W. Niebert, S. A. Atlas, T. M. Guenther, and R. E. Kouri, in "Polycyclic Hydrocarbons and Cancer," Vol. 2, eds. H. V. Gelboin and P. O. P. Ts'o (Academic Press: New York, 1978), pp. 347-390.
178. J. J. McCormick and V. M. Maher, in "Polycyclic Hydrocarbons and Cancer," Vol. 2, eds. H. V. Gelboin and P. O. P. Ts'o (Academic Press: New York, 1978), pp. 221-232.
179. I. Berenblum, "Mechanisms of Tumor Promotion and Co-carcinogenesis," in Carcinogenesis, A Comprehensive Survey, eds. T. J. Slaga, A. Sivak, and R. K. Boutwell (Raven Press: New York, 1978), pp. 1-10.
180. B. C. Casto, W. J. Pieczynski, and J. A. DiPaolo, Cancer Res. 34, 72-78 (1974).

181. P. Pulkrabek, S. Leffler, I. B. Weinstein and D. Grunberger, Biochemistry 16, 3127-3132. (1977).
182. M. Radman, G. Villani, S. Boiteux, M. Defais, P. Caillet-Fauquet, and S. Spadari, in "Origins of Human Cancer," Book B, eds. H. H. Hiatt, J. D. Watson, and J. A. Winsten (Cold Spring Harbor Laboratory, 1977), pp. 903-922.
183. H. B. Gamper, A. S.-C. Tung, K. Straub, J. C. Bartholomew, and M. Calvin, Science 197, 671-674 (1977).
184. J. Cairns, "Thoughts on Cancer Research," in Origins of Human Cancer, Book C, eds. H. H. Hiatt, J. D. Watson, and J. A. Winsten (Cold Spring Harbor Laboratory, 1977), pp. 1813-1820.

Appendix A

Analysis of (+) anti-Diol Epoxide-DNA Adducts by Field Desorption Mass Spectrometry

As described in chapters 4 and 5, the high polarity and extreme thermal lability of the diol epoxide-DNA adducts necessitated the use of chemical derivatization (permethylation or persilylation) prior to analysis by conventional electron impact mass spectrometry. We therefore undertook an investigation of the use of a relatively new ionization technique, field desorption (FD), in analyzing structures of this type. This investigation was pursued in collaboration with Dr. A.L. Burlingame of the National Biomedical Mass Spectrometry Resource, University of California, Berkeley.

Conventional electron impact (EI) and chemical ionization (CI) techniques rely on simple heating under high vacuum to effect volatilization of the compound under study, followed by ionization in the gas phase. This technique does not work with the polar, thermally labile structures which are often of interest to biological researchers; hence the use of chemical derivatization. Rapid heating techniques (ca. 10^4 deg.sec.⁻¹), while showing some promise, do not have the requisite reproducibility or sensitivity for use with unknowns which are available in submicrogram quantities. In field desorption, ionized sample molecules are produced directly from the solid sample by application of a high electric field. The ionized sample molecules are typically produced with very low internal energy, so that the bulk of the ion current is carried by molecular (M^+) or quasi-molecular ($M + H^+$) ions.

Field desorption mass spectrometry is thus the technique of choice for obtaining molecular weight information on polar, labile structures.

The mechanism(s) of field desorption is currently a matter of some dispute. An analogy is usually made with field ionization, where gas phase molecules are ionized by passage through an intense electric field (ca. 10^5 V cm⁻¹) near a clean metal surface.¹ The potential energy diagrams in figure 1 define the parameters involved in field ionization. The potential energy of the valence electron of a hydrogen atom is represented in figure 1a as a function of distance from an ideally smooth metal surface. At regions $r > 0$, a perfect vacuum exists. The conduction band of the metal is filled with electrons up to the Fermi level μ . An amount of energy equal to the work function ϕ must be transferred to an electron at the Fermi level in order to remove it from the metal to infinity. Figure 1a represents the electronic ground state of the valence electron of a hydrogen atom at a distance d from the metal surface. In order to remove the valence electron to an infinitely large, positive value of r , an ionization energy I must be applied to it. In the presence of an electric field V_f , the potential energy due to the electric field (eFr) must be superimposed on that of the atom. The resulting potential well for the valence electron is indicated in figure 1b. At a certain minimum distance from the metal surface, the energy level of the valence electron of the hydrogen atom is raised to the Fermi level μ by the external field. Under these conditions the potential energy barrier between the hydrogen atom and the metal surface has a width of a few electron volts, and there exists a finite probability that the valence electron can tunnel from the hydrogen atom into the metal. The resulting ion H^+ can then be focussed

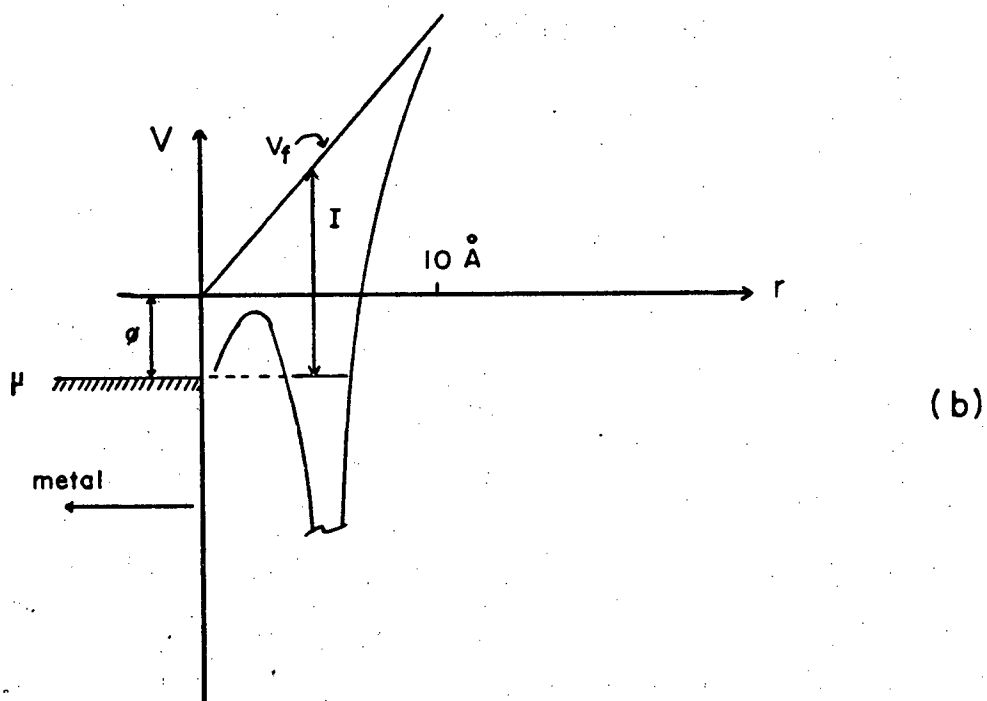
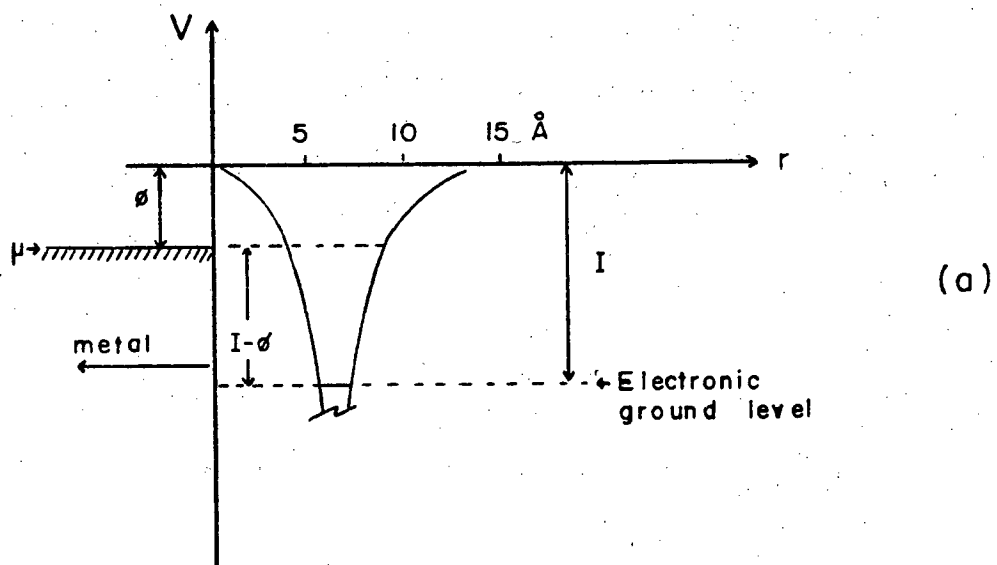
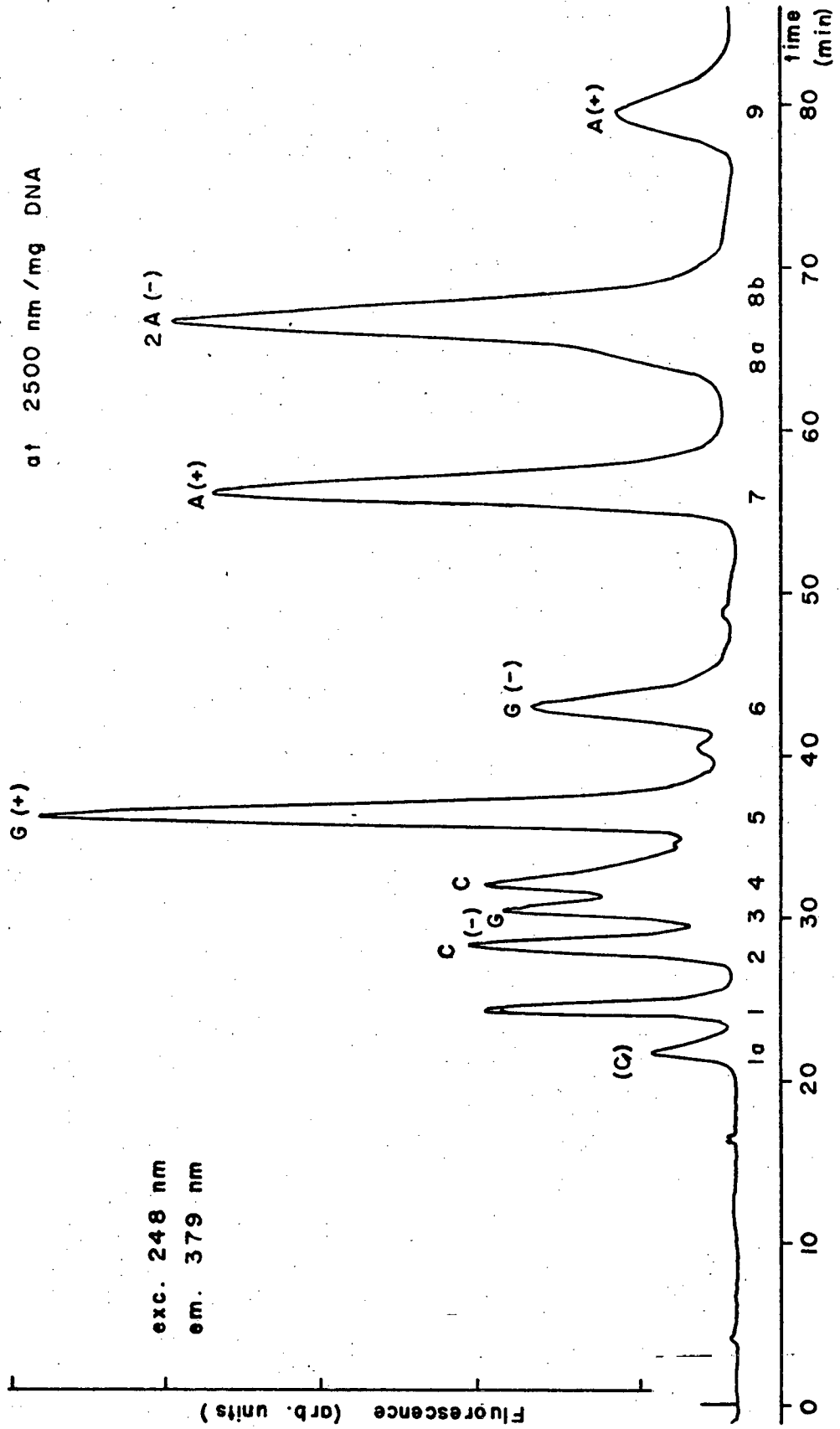

Figure 1: Potential energy diagram for field desorption¹

and analyzed in a conventional magnetic sector mass spectrometer.

With much higher electric fields (ca. 10^8 V cm⁻¹), atoms or molecules present in an adsorbed layer on the anode can be ionized directly to form gas phase ions. This process is termed "field desorption". In order to achieve a high electric field gradient, advantage is made of the local field enhancement that takes place in the vicinity of sharp edges or tips. The growth of such microneedles onto field anodes is called "activation"; conventional activated field emitters are made by growing microneedles from benzonitrile onto a 10 micron diameter tungsten wire at high temperature (ca. 1000°) in the presence of an electric field.² This results in the tungsten wire being coated with a dense growth of "whisker" needles, normally between 20 and 40 microns in length. The sample is then applied to this wire as a solution containing 0.1- 1.0 µg. The sample-coated field anode is then placed in the FD ion source of the mass spectrometer, and a potential of +12 kV relative to an extractor electrode is applied to the anode. Under these conditions an ion beam composed of either M⁺ or (M + H⁺) is formed, which can then be focussed and analyzed in the same fashion as an ion beam formed by conventional electron-impact or chemical ionization. In actual practice, the field anode must also be heated by passing a small current (0- 20 mA) through the tungsten wire. A given sample will usually desorb at a characteristic current, termed the "best emitter temperature", or BET. Also, cationized molecules (M + Na⁺) and cluster ions (M + MH⁺, M + 2Na⁺) are sometimes observed. These effects are not predicted by the simple electron-tunnelling mechanism outlined above, and researchers have attempted to develop more comprehensive theories of field desorption involving

**Figure 2: Adducts from DNA
modified by (\pm) anti-diol epoxide
at 2500 nm/mg DNA**



effects such as electrophilic attack by cations (Na^+ , etc.) or protons, proton or electron transfer reactions, and ion pair formation and separation that can take place under high field conditions.^{3,4} The actual role of the electric field is thus complicated, and probably involves several different mechanisms of ionization which can occur simultaneously.

The HPLC fractions p1-p7 as well as peaks 8 and 9 (figure 2) were analyzed using this technique, giving the results listed in Table 1. As indicated, all adducts whose structures had been derived by high resolution mass spectrometry of chemically derivatized samples gave the expected molecular ions, as well as cationized molecular ions ($\text{M} + \text{Na}^+$) at higher emitter temperatures. In addition, fragment ions corresponding to loss of the deoxyribose moiety ($\text{M} - 117$) were sometimes observed. Of particular interest were the results on fractions that had not been previously analyzed because of the small quantities of material ($<1 \mu\text{g}$) available. Thus peak 6 yielded ions at m/z 569, 592, and 453, confirming its identity as a deoxyguanosine adduct. Peak 9 and the two components of peak 8 (separated by recycle HPLC) gave ions at m/z 576, 553, and 458, confirming their identity as deoxyadenosine adducts. The first peak in figure 2, peak 1a, gave ions at m/z 529 as well as higher molecular weight species at m/z 750- 900. These higher molecular weight adducts apparently correspond to diol epoxide-modified dinucleotides that were not completely hydrolyzed by the enzymatic digestion to monomeric units. The relatively large peakwidth and assymmetric shape of peak 1a are indicative of the presence of several unresolved components.

Table 1. FD/MS on monomeric diol epoxide-DNA adducts		
Peak # (figure 2)	m/z	identity
1a	529, >750	deoxycytidine adduct plus modified oligonucleotides
1	320	tetrahydroxy-tetrahydrobenzo(a)pyrene
2	529,552	deoxycytidine adduct
3	569, 592	deoxyguanosine adduct
4	529, 552, 320	deoxycytidine adduct, plus tetrahydroxy-tetrahydrobenzo(a)pyrene
5	569, 592	deoxyguanosine adduct
6	569, 592	deoxyguanosine adduct
7	553, 576	deoxyadenosine adduct
8a, 8b	553, 576	deoxyadenosine adduct
9	553, 576	deoxyadenosine adduct

Field Desorption/ Collision-Induced Dissociation (FD/CID) Mass

Spectrometry:

The absence of significant fragmentation observed in the FD mass spectra of fractions 1- 9 (above) is advantageous for molecular weight analysis, but gives little information about structure. We therefore investigated the use of a collisional activation chamber to raise the internal energy of field-desorbed ions and induce unimolecular decompositions prior to mass analysis. Figure 3 is a schematic representation of the instrument configuration; a modified Kratos/AEI MS-902 equipped with a combined FD/EI ion source was used. Helium gas was admitted to the EI chamber of the source through a capillary leak; field-desorbed ions traversing this region undergo collision with the helium and convert a portion of their translational energy (8 kV) into internal

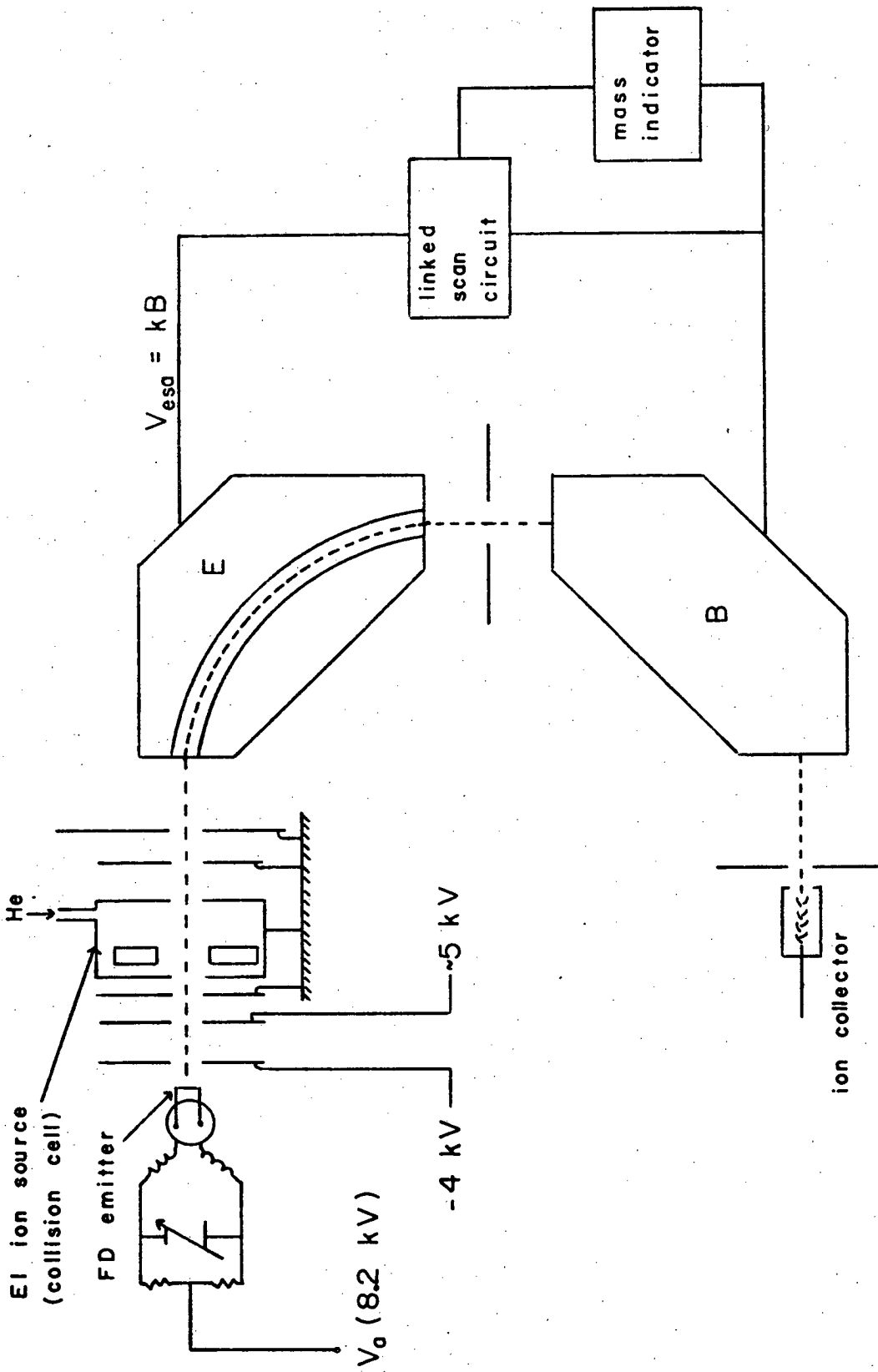

Figure 3: Instrument configuration for FD/CID mass spectrometry

(electronic) energy.⁵ In addition to this, a linked scan of the electric and magnetic sectors of the instrument was employed in order to observe the collisionally-induced metastable species. Scanning both sectors so that the ratio of B/E remains constant allows the observation of all daughter ions m_2^+ formed from M_1^+ in the first field-free region of the instrument.⁶ This is easily derived by examining the conditions for transmission of an ion M_1^+ at velocity v_1 by the electric (E) and magnetic (B) sectors:

$$\frac{M_1 v_1^2}{R} = eE_1 \qquad \frac{M_1 v_1^2}{r} = ev_1 B_1$$

For the unimolecular decomposition $M_1^+ \rightarrow m_2^+ + m_3$, the kinetic energy of M_1^+ will be partitioned according to the ratio of m_2 and m_3 to M_1 ; m_2^+ will therefore have velocity v_1 . Ion m_2^+ will therefore be transmitted by the electric sector when

$$E_2 = \left(\frac{m_2}{M_1} \right) E_1$$

and by the magnetic sector when

$$B_2 = \left(\frac{m_2}{M_1} \right) B_1$$

By tuning the instrument to transmit mass M_1^+ and then scanning both E and B in a constant ratio, all of the daughter ions derived from M_1^+ will be observed. This B/E scan is particularly interesting when used for FD mass spectrometry, since it assures that observed ions are

related to one another. For example, if the ion at m/z 453 in the FD spectrum of the deoxyguanosine adduct p5 was not observed in a B/E scan, then it is likely that it represents an additional component of mass 453 in the HPLC fraction. As figure 4a demonstrates, however, this ion is observed in a linked scan from mass 569, and therefore is derived by unimolecular decomposition from mass 569. Linked scanning should prove invaluable in the mass spectrometric analysis of mixtures, since fragment ions could be easily distinguished from ions due to different components.

Figure 4b represents a nominal mass plot of the fragments generated from mass 569 (M^+ for the deoxyguanosine adduct, p5) by collision-induced dissociation. The observed fragments are similar to those obtained by electron-impact mass spectrometry on the permethylated adducts (see chapter 4). Figure 5 represents a schematic fragmentation pathway to account for these ions. The observed species are consistent with the assigned structure.

These results confirm the feasibility of using a field desorption ion source coupled with a collisional activation cell to analyze highly polar, thermally labile compounds without prior chemical derivatization. The use of linked scanning techniques allows the observation of fragment ions produced from a particular precursor ion without interference from other molecular weight species present in the mixture. The high sensitivity of the technique (sample requirements are 0.1- 1.0 μg) should allow direct analysis of metabolites and macromolecule adducts obtained from in vivo experiments.⁷

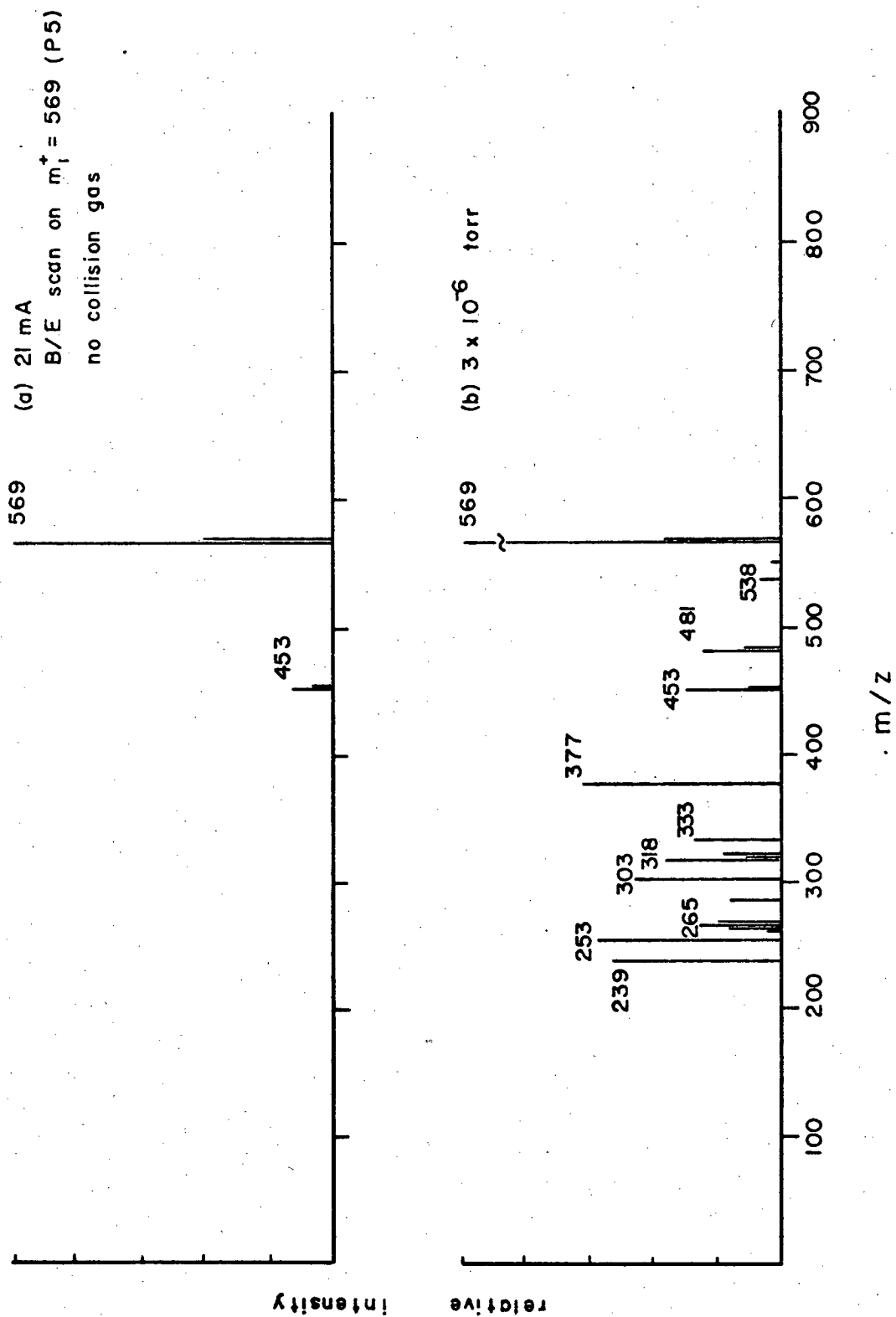
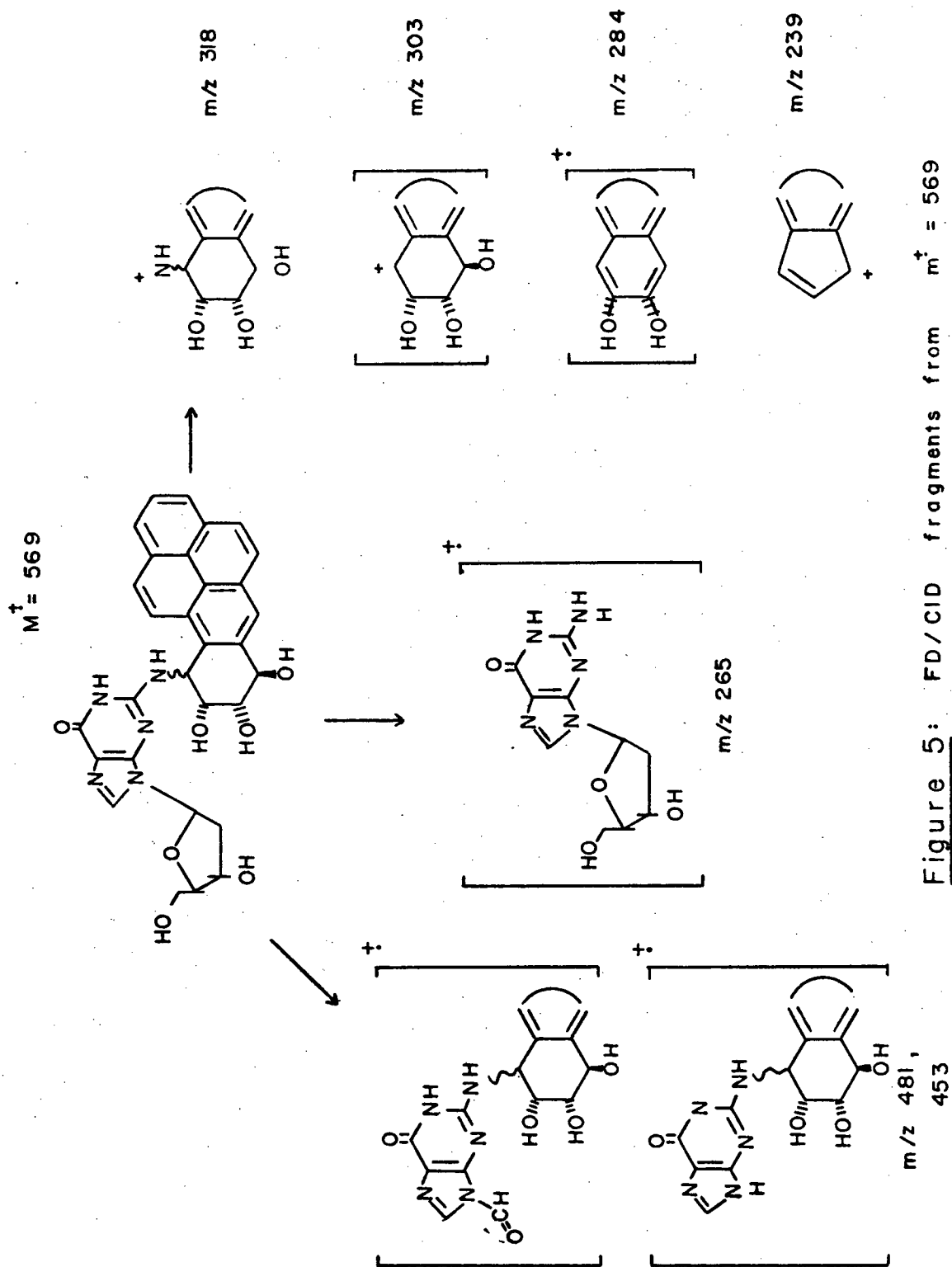

Figure 4 : FD/CID mass spectra on P5 ($m/z = 569$)



References

1. H.D. Beckey, in "Principles of Field Ionization and Field Desorption Mass Spectrometry" (Pergamon Press: Oxford, 1977), pp. 1-24.
2. H.D. Beckey, E. Hilt, and H.R. Schulten, J. Phys. E.: Sci. Instr. **6**, 1043-1049 (1973).
3. H.D. Beckey, op. cit., pp. 108-172.
4. J.F. Holland, B. Soltmann, and J.L. Dye, "Ion Generation and Collection in Field Desorption Mass Spectrometry", presented at the 26th Annual Conference on Mass Spectrometry and Allied Topics, May 28- June 2, 1978, St. Louis, Mo.
5. K. Levsen and H. Schwartz, Angew. Chem., Int Ed. Engl. **15**, 590-596 (1976).
6. A.P. Bruins, K.R. Jennings, and S. Evans, Int. J. Mass Spectrom. Ion Phys. **26**, 395-399 (1978).
7. K. Straub, T. Meehan, H. Kambara, and A.L. Burlingame, "Field Desorption/ Collision-Induced Dissociation (FD/CID) Mass Spectrometry of the Free Benzo(a)pyrene Diol Epoxide-DNA Adducts", presented at the 26th Annual Conference on Mass Spectrometry and Allied Topics, May 28- June 2, 1978, St. Louis, Mo.

0

This report was done with support from the Department of Energy. Any conclusions or opinions expressed in this report represent solely those of the author(s) and not necessarily those of The Regents of the University of California, the Lawrence Berkeley Laboratory or the Department of Energy.

Reference to a company or product name does not imply approval or recommendation of the product by the University of California or the U.S. Department of Energy to the exclusion of others that may be suitable.

TECHNICAL INFORMATION DEPARTMENT
LAWRENCE BERKELEY LABORATORY
UNIVERSITY OF CALIFORNIA
BERKELEY, CALIFORNIA 94720