

Lawrence Berkeley National Laboratory

Recent Work

Title

A COMBUSTION METHOD FOR THE SIMULTANEOUS DETERMINATION OF TOTAL CARBON AND G-14 ACTIVITY

Permalink

<https://escholarship.org/uc/item/1b57b4tk>

Authors

Gabourel, John D.

Baker, Mary Jane

Koch, Charles W.

Publication Date

1954-07-01

UCRL 2650

UNCLASSIFIED

UNIVERSITY OF
CALIFORNIA

*Radiation
Laboratory*

TWO-WEEK LOAN COPY

*This is a Library Circulating Copy
which may be borrowed for two weeks.
For a personal retention copy, call
Tech. Info. Division, Ext. 5545*

BERKELEY, CALIFORNIA

DISCLAIMER

This document was prepared as an account of work sponsored by the United States Government. While this document is believed to contain correct information, neither the United States Government nor any agency thereof, nor the Regents of the University of California, nor any of their employees, makes any warranty, express or implied, or assumes any legal responsibility for the accuracy, completeness, or usefulness of any information, apparatus, product, or process disclosed, or represents that its use would not infringe privately owned rights. Reference herein to any specific commercial product, process, or service by its trade name, trademark, manufacturer, or otherwise, does not necessarily constitute or imply its endorsement, recommendation, or favoring by the United States Government or any agency thereof, or the Regents of the University of California. The views and opinions of authors expressed herein do not necessarily state or reflect those of the United States Government or any agency thereof or the Regents of the University of California.

UCRL-2650
Unclassified Chemistry

UNIVERSITY OF CALIFORNIA

Radiation Laboratory

Contract No. W-7405-eng-48

A COMBUSTION METHOD FOR THE SIMULTANEOUS DETERMINATION
OF TOTAL CARBON AND CARBON-14 ACTIVITY

John D. Gabourel
Cml. C. Medical Laboratories,
Army Cml. Center, Maryland

and

Mary Jane Baker and Charles W. Koch
University of California Radiation Laboratory
and Department of Chemistry

July 13, 1954

Berkeley, California

A COMBUSTION METHOD FOR THE SIMULTANEOUS DETERMINATION
OF TOTAL CARBON AND CARBON-14 ACTIVITY

Contents

Abstract	3
Introduction	4
Apparatus and Materials	5
Preparation of the Tube Packing	7
Reagents for the Volumetric Method	8
Combustion Procedure	8
Volumetric Determination of Carbon	9
Results	10
Summary	16
Acknowledgments	16
References	17

A COMBUSTION METHOD FOR THE SIMULTANEOUS DETERMINATION
OF TOTAL CARBON AND CARBON-¹⁴ ACTIVITY

John D. Gabourel, Mary Jane Baker, and Charles W. Koch

Radiation Laboratory, Department of Physics,
University of California, Berkeley, California

July 13, 1954

ABSTRACT

A combustion procedure has been developed for the determination of total carbon and C¹⁴ using granular quartz and manganese dioxide for the combustion tube packing. Neither of these substances retains appreciable quantities of C¹⁴O₂. It has been demonstrated that total carbon can be determined using this procedure, either by the conventional method employing absorption of the carbon dioxide by Ascarite or by absorption of the carbon dioxide in a known amount of standard sodium hydroxide. When absorption in standard base was the procedure used, the carbonate was precipitated as barium carbonate and the excess base was back-titrated with standard hydrochloric acid to a phenolphthalein endpoint. The precipitate was filtered and a barium carbonate cake was prepared and counted.

When the volumetric method was used for a carbon determination, the hydrogen also could be determined if a protective tube of Anhydrone was placed between the absorption tube for water and the sodium hydroxide absorber for the carbon dioxide.

For either of these procedures the results obtained were comparable in accuracy to the conventional combustion procedure of Pregl.

A COMBUSTION METHOD FOR THE SIMULTANEOUS DETERMINATION
OF TOTAL CARBON AND CARBON- 14 ACTIVITY

John D. Gabourel, Mary Jane Baker, and Charles W. Koch

Radiation Laboratory, Department of Physics,
University of California, Berkeley, California

July 13, 1954

INTRODUCTION

An accurate carbon determination for use with radioactive C^{14} has long been needed. Buchanan and Nakao² provided such a method, but the apparatus is complex, and a simpler one is desirable for routine analytical work. Standard wet-combustion techniques, such as the Van Slyke - Folch method and the periodate type digestion, are not adequate by themselves for many compounds, especially fats and other complex substances found in biological materials. The standard Pregl combustion would be ideal except that radioactive cross-contamination occurs between consecutive samples³ owing to the holdback of small amounts of carbon dioxide as well as of water on the packing in the combustion tube. A tube packing different from the conventional one described by Pregl has been developed which does not retain any appreciable quantity of carbon dioxide and which gives an accuracy comparable to that of the standard method.

The principle is the same as that for the standard Pregl determination, in which a high-temperature combustion in oxygen is employed to convert the carbon and hydrogen in the sample quantitatively to carbon dioxide and water. For C^{14} activity measurements, the carbon dioxide is absorbed in a standard sodium hydroxide solution. The amount of carbon dioxide then is determined by titration of the excess base. If a hydrogen analysis is

required, the water is absorbed by Anhydrone, using a standard Pregl absorption tube⁵. The carbon dioxide is collected either by passing the gas over Ascarite or by absorbing it in sodium hydroxide. The latter method always is employed when the C^{14} activity is required.

Combustion to the desired products is made possible by passing the combustion gases over hot platinum gauze and granular quartz at $900^{\circ} - 950^{\circ} C$ (see Fig. 1). Interfering substances such as the halogens, sulfur, and phosphorus are removed by silver wool at $175^{\circ} C$. Any nitrogen dioxide that is formed during the combustion is removed by manganese dioxide. The use of manganese dioxide in place of lead dioxide has been described by Belcher and Ingram¹ and also by Kirsten⁴. In the present investigation the manganese dioxide was included in the combustion tube packing and was maintained at $175^{\circ} C$ in the thermostatic sleeve following the combustion furnace.

APPARATUS AND MATERIALS

The automatic semimicro carbon and hydrogen apparatus obtained from E. H. Sargent and Company is suitable for this procedure. The furnaces tolerate continuous operation over the temperature range required. The pressure regulator and oxygen purification part of the combustion train is as described by Pregl,⁶ and is not shown in this report. Standard combustion tubes made of quartz and of Vycor may be used. If C^{14} activity is to be determined, or if the carbon is determined volumetrically, an absorber such as that shown in Fig. 2 is used. The inner member is made from a fritted glass disperser (Corning 39533-C). With the concentration of base used, this absorber removes carbon dioxide quantitatively from the gas stream even when oxygen flow rates are as great as 25 ml per minute. The outer vessel (Fisher 3-038) has a capacity of 125 ml.

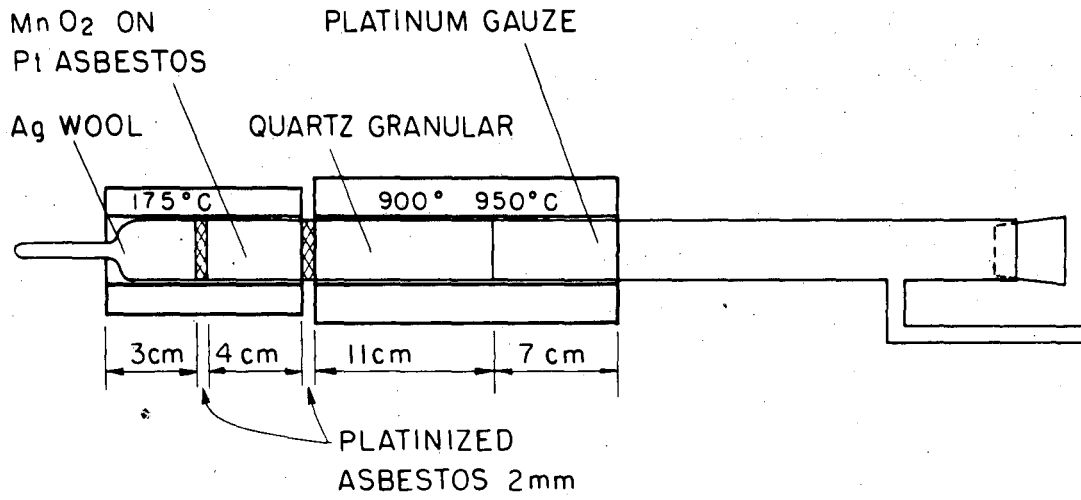

MU-7993

Fig. 1.

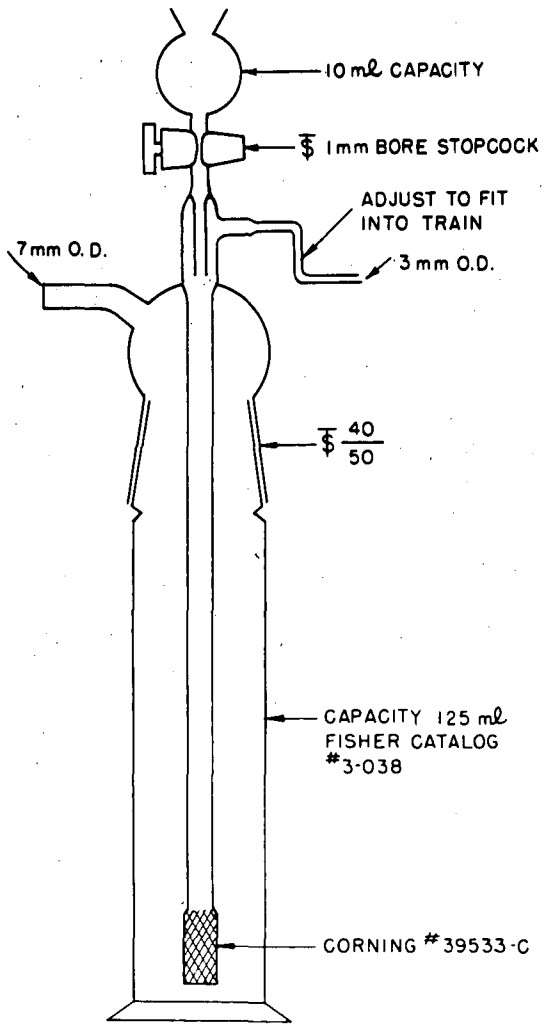

MU-7994

Fig. 2.

For the gravimetric procedure, the conventional Mariotte bottle is used to control gas flow. A twenty-liter Mariotte bottle is used to control the oxygen flow rate for the absorption of carbon dioxide by sodium hydroxide. A pressure head of approximately four feet of water is needed to overcome the back pressure of the fritted cylinder in the absorber.

Preparation of the Tube Packing

The materials used for the combustion tube packing require careful preparation. The granular quartz (30- to 50- mesh) must be cleaned with hot cleaning solution (concentrated sulfuric acid saturated with potassium or sodium dichromate), thoroughly washed with distilled water, and dried. The platinum gauze is cleaned with hot, concentrated nitric acid. Silver wool is used as obtained from Fisher Scientific Company (Chemical Catalog S-163). Platinized asbestos (5% Pt by weight) is used as obtained from J. T. Baker Chemical Company (Catalog 4-0922). It is important that the manganese dioxide be the purest available, and it must be essentially free of alkaline earths. Baker's Analytical Reagent Grade manganese dioxide with a reported assay of 99.5 — 100.5 has proved satisfactory. The analysis listed for this preparation showed alkaline earths as sulfate present in the amount of 0.02%. Manganese dioxide also is prepared by precipitation from permanganate in acid solution using enough hydrogen peroxide to stoichiometrically reduce the permanganate to manganese dioxide. The precipitate is thoroughly washed and is dried in vacuum at 100° C for 15 hours.

Reagents for Volumetric Method

1. Standard hydrochloric acid, approximately 0.42 M, was prepared from concentrated cp hydrochloric acid and standardized against primary-standard sodium carbonate.

2. Standard sodium hydroxide, approximately 0.4 M, was prepared from saturated sodium hydroxide. The bulk of the carbonate was removed from the saturated solution by filtration. This carbonate-free, saturated solution was then diluted to approximately 0.4 M with carbon dioxide — free distilled water and protected from further contamination by passing the incoming air over soda lime or Ascarite. This solution was standardized against standard hydrochloric acid prepared above under the same conditions as during actual analyses.

3. Barium chloride, 1.0 M, was prepared from cp reagent and was protected from carbon dioxide.

4. Distilled water was boiled to remove carbon dioxide.

COMBUSTION PROCEDURE

To insure complete combustion, the long furnace (see Fig. 1) is operated at $900^{\circ} - 950^{\circ}$ C. The temperature of the thermostatic sleeve is 175° C. The movable furnace is operated at several temperatures in the course of the analysis. During the first burning the movable furnace is operated at $300^{\circ} - 500^{\circ}$ C. Flashing of the sample must be prevented to avoid incomplete combustion. Once the sample has been charred and there no longer is danger of flashing, the temperature is increased. For the first burning, the speed of the movable burner should not exceed six millimeters per minute. For the second burning, which is the final one,

the temperature of the movable furnace is increased to 850° C and its speed is held to 16 millimeters per minute. A gas sweeping time of at least five minutes is allowed after the final burning of the sample.

The oxygen flow rate is dependent on sample size. The standard flow rate of 4 to 5 milliliters per minute is used for samples from 3 to 6 mg. For samples as large as 30 mg the flow rate is increased to 20 to 25 milliliters per minute. Approximately 40 to 45 minutes is required for each analysis.

When activity measurements are made, the sample size should be sufficiently large to provide barium carbonate cakes of critical thickness. It is advisable to keep all barium carbonate cakes above critical thickness to avoid possible errors due to self-absorption. When a smaller sample is necessary, a critical weight curve must be obtained to correct for the varying effect of self-absorption. For the filtration apparatus used by the authors, the critical weight corresponds to 40 mg of barium carbonate (apparatus obtainable from Tracerlab, Inc. - Catalog No. E-88).

VOLUMETRIC DETERMINATION OF CARBON

Ten milliliters of standard sodium hydroxide are pipetted into the absorbing vessel. Carbon dioxide — free distilled water is added until the absorber is approximately three-fourths full. The absorber is stoppered with the inner member and placed in the combustion train. The 10-ml bulb at the top of the absorber (see Fig. 2) is filled with distilled water. This water is used to wash the inside of the disperser tube and the fritted cylinder after the combustion is completed. When the combustion is completed, the absorber is detached from the train.

The bubbler is opened and the inner member is washed with distilled water, and the washings are collected in the outer vessel. Nitrogen gas or carbon dioxide -- free air is bubbled through the solution. In addition to preventing absorption of carbon dioxide from the air, the bubbling gas aids in stirring the solution during titration. Three milliliters of 1.0 M BaCl₂ (a two- to threefold excess) are added to the absorbing solution followed by three drops of 0.25% phenolphthalein indicator. The excess base in the resulting mixture is titrated with standard hydrochloric acid. A 10-ml microburet graduated in 0.02-ml divisions is used for the titration. Care must be taken to add the hydrochloric acid slowly in order to avoid local high concentration of hydrogen ion, which would result in loss of carbon dioxide from the sample. After the titration is completed, the solution is made slightly alkaline (pink to phenolphthalein) for the preparation of a barium carbonate cake for counting. A Tracerlab SC-16 internal flow counter, employed as a G-M counter, is used for activity determinations.

RESULTS

The combustion tube packing described herein was first tested using the volumetric method to determine carbon content. Typical results are listed in Table I.

After it was demonstrated that the tube packing gave reasonably reproducible carbon analyses, possible C¹⁴ cross - contamination was investigated. That C¹⁴ cross - contamination did not occur is shown in Table II. The samples were analyzed in the order shown in the table.

Table I

Carbon Analyses Using the Volumetric Method				
Sample	Sample wt. mg	% C		Deviation %
		Theor.	Found	
Benzoic acid	10.21	68.85	69.5	+1.0
	9.05		69.3	+0.7
	14.25		68.2	-1.0
Sucrose	18.51	42.1	42.1	0.0
	17.35		42.6	+1.1
	20.27		41.9	-0.5
	21.96		42.2	+0.3
	15.22		42.5	+1.0
Oxalic acid Dihydrate	38.77	19.0	19.0	0.0
	45.05		18.9	-0.5

Table II

Barium Carbonate Activity Measurements Showing Absence of Cross-Contamination		
Sample	Activity BaCO ₃ net counts / minute	
1. Inactive galactose	0.1	
2. Randomly labeled lactose	11,732	
3. Inactive galactose	0.6	
4. Randomly labeled lactose	11,600	
5. Inactive galactose	0.0	
6. Randomly labeled lactose	11,700	
7. Inactive galactose	0.2	
8. Randomly labeled glucosazone	11,976	
9. Inactive galactose	0.3	
10. Randomly labeled glucosazone	12,010	
11. Inactive galactose	0.4	

The reliability of the carbon determination using the quartz tube packing was tested by collecting the carbon dioxide and water in conventional Ascarite and Anhydrone absorption tubes. The flow rate was maintained at the standard rate of 4 to 5 ml per minute. The results obtained for carbon are listed in Table III. The Anhydrone tube was used to remove water before absorption of the carbon dioxide on Ascarite, but the quantity of water produced was not determined.

Table III

Carbon Analyses Using the Gravimetric Method			
Sample	% C		Deviation %
	Theor.	Found	
Benzoic acid 4.0-4.3 mg	68.85	68.74	-0.2
		68.80	-0.1
Acetanilide 3.6-4.4 mg	71.09	71.25	+0.2
		71.13	+0.1
		71.00	-0.1
Anthracene 3.0-3.8 mg	94.34	93.86	-0.5
		94.07	-0.3
		94.19	-0.2
		93.94	-0.4
		93.74	-0.7
		93.75	-0.7
Fumaric acid 4.1-5.8 mg	41.31	41.47	+0.4
		41.47	+0.4
		41.41	+0.2
Chlorobenzoic acid 3.5-5.0 mg	53.67	53.97	+0.6
		53.80	+0.2
		53.50	-0.3
		53.88	+0.4
Iodobenzoic acid 5.2-7.3 mg	22.31	22.55	+1.1
		23.04	+3.3
		22.41	+0.4
		22.53	+1.0

These results show that the carbon analyses obtained using this combustion tube packing are comparable to those obtained by the standard carbon-hydrogen procedure. Table IV lists analyses for both carbon and hydrogen using the quartz packing.

Table IV

Carbon and Hydrogen Analyses Using the Gravimetric Method						
Sample	% C		Dev. %	% C		Dev. %
	Theor.	Found		Theor.	Found	
Benzoic acid 3.5-5.1 mg	68.85	69.11	+0.4	4.94	4.93	0
		68.98	+0.2		4.97	+1
		69.29	+0.7		5.01	+1
		69.33	+0.7		4.82	-2
		68.61	-0.4		4.78	-3
		69.07	+0.3		4.97	+1
		69.21	+0.5		4.83	-2
		69.05	+0.3		4.98	+1
	68.91	+0.1		5.03	+2	
Acetanilide 3.4-4.6 mg	71.09	71.33	+0.3	6.71	6.88	+3
		70.84	-0.4		6.82	+2
		70.98	-0.1		6.70	0
		71.20	+0.1		6.88	+3
		70.99	-0.1		6.68	0
Chloroacetanilide 3.6-5.4 mg	56.65	56.48	+0.3	4.76	4.80	+1
		56.68	+0.1		4.72	-1
		56.55	-0.2		4.66	-2
		56.56	-0.2		4.86	+2

Finally, a series of experiments was carried out in which the hydrogen was determined gravimetrically and the volumetric method was used for carbon. A short Anhydrone absorber was placed between the absorption tube for water and the sodium hydroxide absorber as a precaution against back-diffusion of water vapor from the carbon dioxide collector. For these measurements, in which 4- to 10-mg samples

were used, the carbon dioxide was collected in standard 0.1 M base and the excess base was back-titrated with standard 0.1 M acid. Two milliliters of 1.0 M BaCl₂ were used to precipitate carbonate from the alkaline solution. The carbon dioxide collector was similar to the one shown in Fig. 2 but the total volume of the bottle was approximately 30 ml, with a liquid height for 10 ml of solution equal to 10 cm. The data are presented in Table V.

Table V

Sample	% C		Dev. %	Theor.		Dev. %
	Theor.	Found		Theor.	Found	
Acetanilide 5.5-8.1 mg	71.09	71.1	0.0	6.71	6.65	-1
		71.3	+0.3		6.76	+1
		71.2	+0.1		6.70	0
		71.5	+0.6		6.61	-2
Chloroacetanilide 5.8-8.4 mg	56.65	56.4	-0.4	4.76	4.77	0
		56.7	+0.1		4.62	-3
		56.5	-0.3		4.80	+1
		56.7	+0.1		4.89	+3
Benzoic acid 4.5-5.2 mg	68.85	68.8	-0.1	4.94	4.92	0
		68.7	-0.2		4.96	0
		68.9	+0.1		4.99	+1

For the data listed in Table V, flow rates approximating 5 ml per minute were used. Greater rates of flow were not attempted. In addition to the data listed, it was found that no appreciable quantity of C¹⁴ was held up by the Anhydrone in the course of several combustions in which inactive benzoic acid was analyzed after samples of C¹⁴-labeled glucose having approximately 2000 counts per minute per milligram.

SUMMARY

The combustion tube packing employed in this study eliminates cross-contamination due to C^{14} holdup. It affords a more reliable analysis for carbon than do wet digestion procedures, and permits a simple acid-base titration for the analysis of carbon in organic samples which contribute other acidic gases on combustion. In addition, the combustion method has the advantage that from a single determination one can obtain a quantitative analysis for carbon and hydrogen with an accuracy comparable to the standard determination as well as an analysis for C^{14} activity.

The new tube packing has been used extensively by Kleiber and the Davis Tracer Team* for the combustion of C^{14} -labeled milk products, and also by Gosselin, Gabourel, Kalser, and Wills⁷ for tissue analysis of mice and rats for total carbon and C^{14} . This method has proved to be very satisfactory for routine analysis on biological materials.

ACKNOWLEDGMENTS

The authors wish to acknowledge the cooperation of Professor Max Kleiber and the Davis Tracer Team.

This work was supported in part by the United States Atomic Energy Commission.

* Division of Animal Husbandry, University of California, Davis, California

REFERENCES

1. R. Belcher and G. Ingram, Anal. Chim. Acta 4, 124 (1950).
2. D. L. Buchanan and A. Nakao, J. Am. Chem. Soc. 74, 2389 (1952).
3. M. Calvin, "Isotopic Carbon", John Wiley and Sons, New York, 1949, p. 82-88.
4. W. Kirsten, Anal. Chem. 25, 74 (1953).
5. F. Pregl and J. Grant, "Quantitative Organic Microanalysis", The Blakiston Co., Philadelphia, 1951, 5th edition, p. 44-46.
6. Ibid, p. 37-48.
7. To be submitted to J. Pharm. Exper. Therap.