

UC Irvine

UC Irvine Previously Published Works

Title

Luminance discrimination of brief flashes under various conditions of adaptation

Permalink

<https://escholarship.org/uc/item/1bg026w7>

Journal

The Journal of Physiology, 176(2)

ISSN

0022-3751

Authors

CORNSWEET, TN

PINSKER, HM

Publication Date

1965

DOI

10.1113/jphysiol.1965.sp007551

Copyright Information

This work is made available under the terms of a Creative Commons Attribution License, available at

<https://creativecommons.org/licenses/by/4.0/>

Peer reviewed

LUMINANCE DISCRIMINATION OF BRIEF FLASHES UNDER VARIOUS CONDITIONS OF ADAPTATION

BY T. N. CORNSWEET AND H. M. PINSKER

From the Department of Psychology, University of California, Berkeley, U.S.A.

(Received 25 May 1964)

Weber's law states that the just-noticeable change in luminance is a fixed fraction of the base luminance. The classic studies of luminance discrimination have suggested that Weber's law holds only as a rough approximation over an intermediate range of luminances, and clearly breaks down at both low and high luminances (e.g. Barlow, 1957; Pirenne, 1962). However, most of these studies have been conducted under conditions that are somewhat complicated relative to our present understanding of visual processes. We shall argue that luminance discrimination data to be presented here have been collected under conditions easier to interpret in terms of photochemical and neural processes, as well as signal detection theory. Under these simplified conditions, Weber's law is shown to hold exactly over the entire range of luminances from just above absolute threshold to at least five log units above absolute threshold.

METHODS

Apparatus. A schematic diagram of the apparatus is shown in Fig. 1. The source was an automobile tail light bulb run from a constant voltage d.c. power supply. Its radiance was constantly monitored by a photocell, and any changes in radiance were compensated for by adjustments in the current through the bulb. Lens L_1 formed an image of the filament in the plane of the rotating disk shutter, and lens L_2 then collimated the rays. The rays that passed through the beamsplitters BS_1 and BS_2 formed the main path, and fell upon an opaque stop S_2 , in which two holes had been placed one above the other. This stop determined the stimulus configuration as it appeared to the observer in Maxwellian view (see inset, Fig. 1). The stimulus disks fell upon an area of the retina containing both rods and cones. Lens L_3 was at its focal distance from S_2 and from the pupil of the observer's eye, and therefore collimated the rays from the plane of S_2 and formed a filament image in the plane of the pupil. This filament image was 2 mm in diameter, and thus changes in the diameter of the observer's pupil did not appreciably change the retinal illuminance. The rays that were reflected from BS_1 and from mirrors M_1 and M_2 formed the side path, and passed through a special stop S_1 before being recombined with the main path by BS_2 . S_1 consisted of two vanes mounted on a shaft that could be rotated silently about a vertical axis (see inset, Fig. 1). The filament image was small enough, and the rays were well enough collimated that each of the vanes completely blocked the light from the side path at one of the holes in stop S_2 and did not at all block the light at the other hole. Thus, by rotating S_1 ,

LUMINANCE DISCRIMINATION OF BRIEF FLASHES 295

light could be added to either the top or the bottom hole while the other hole remained at the base luminance. We shall refer to the base luminance as L and to the added luminance as ΔL .

The base luminance L was determined by filters F_1 and F_2 , and the added luminance ΔL was determined by filters F_1 and F_3 . By varying F_1 and F_2 in conjunction with each other, L could be held constant while ΔL varied over a very large range. All filters were Wratten neutral density filters. F_1 and F_2 were graduated in half-log unit steps, while

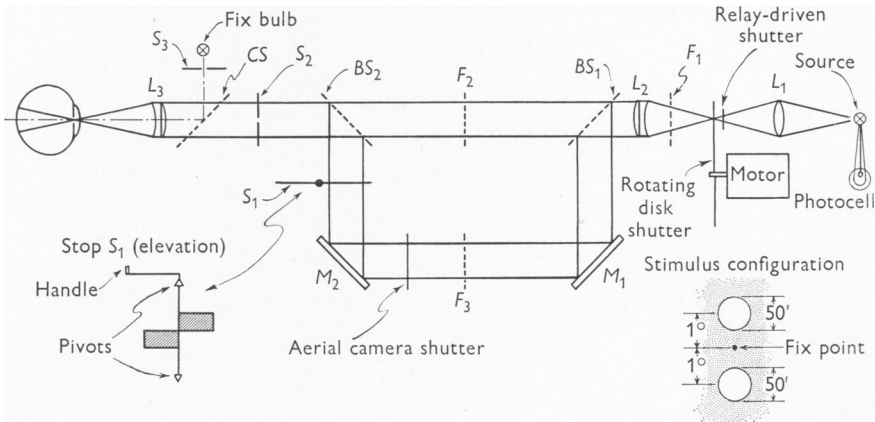

Fig. 1. Schematic diagram of apparatus. Explanation in text.

F_3 was graduated in tenth-log unit steps. All the filters were calibrated in their normal position in the apparatus with a Spectra Brightness Spot Meter (Photo Research Corp., Hollywood, Calif.) whose calibration was checked against a Macbeth Illuminometer. The design of the apparatus permitted accurate calibration of the luminance difference between the two stimulus disks since, when an opaque 'filter' was placed in F_2 , the only light in the plane of the pupil was ΔL .

The fixation point was supplied by a bulb, rays from which passed through a pin-point opening in stop S_3 and were then reflected from the cover-slip CS and collimated by L_3 . It therefore appeared in the plane of S_2 , and was placed midway between the two holes in this stop (see inset, Fig. 1). The luminance of the fixation point was under the control of the observer, who was instructed to keep it at the lowest luminance that permitted good fixation.

The stimuli were delivered in two different ways. In Expts. I and III the aerial camera shutter remained open at all times and the stimuli were delivered by means of the double-shutter arrangement. This double shutter consisted of a rotating disk shutter driven by a synchronous motor, and a relay-driven shutter that opened briefly to allow a single flash to be delivered. In Expt. II, the double shutter remained open at all times and the stimuli were delivered by means of the high quality camera shutter. The actual conditions of stimulation and adaptation will be described in the procedure sections for each of the experiments. The flash durations were measured by means of a photomultiplier tube and an oscilloscope. The half-amplitude duration of the flash delivered by the double shutter was approximately 4.5 msec, and that of the flash delivered by the camera shutter was approximately 3.6 msec.

The observer was enclosed in a light-tight chamber, and great care was taken to eliminate stray light in the apparatus.

Observers. Two male college students served as paid observers. Both observers were used in Expts. I and II, but only observer D. O. was used in Expt. III.

General procedures. Procedures that were used in all three experiments will be described in this section. All observations were made monocularly with the right eye, and the head was held in position by means of a dental impression plate. For 30–45 min before a session the observer wore a patch occluder over his right eye. The final stages of dark adaptation were achieved with the patch occluder removed after the observer entered the light-tight chamber.

During any given experimental session L was constant. On the first trial ΔL was a fixed percentage (150 %) of L . The size of ΔL on successive trials was determined by a modified 'staircase' technique (Cornsweet, 1962). If the observer's judgement was incorrect, ΔL was increased on the following exposure. If his judgement was correct, ΔL remained the same on the following exposure and, if it was again correct (i.e. twice in a row), ΔL was then reduced on the next exposure. In the early part of a session ΔL was changed in 0.3 log unit steps, but after five 'reversals' (i.e. changes from correct to incorrect judgements, or vice versa) the steps were reduced to 0.1 log units for the remainder of the session (see, e.g. Heinemann, 1961).

The threshold ΔL was always taken as the median of the last thirty trials of a given session. Since the sessions contained approximately sixty trials altogether, the first thirty trials served to give the observer practice in making judgements at that base luminance level. This procedure yields a difference threshold close to the difference in luminance that will be judged correctly 75 % of the time.

On each trial the position of ΔL was determined at random. The observer judged either 'top' or 'bottom', indicating which disk he thought had the greater luminance. He was immediately told whether he was right or wrong. Such feed-back is an important aspect of these experiments and will be discussed more fully in a later section.

Two separate determinations were made at each level of L for each observer, and the order of data collection was balanced. The geometric mean of the two determinations was taken as the final measure.

Experiment I

Procedure. The camera shutter remained open throughout this experiment (see Fig. 1). When the observer was ready, he fixated the fixation point and pressed a key which operated the double shutter, thus presenting the two disks simultaneously for 4.5 msec. The temporal sequence of stimuli is shown schematically in the top diagram of Fig. 2.

The observer was fully dark-adapted before the beginning of each session, and care was taken to ensure that he remained dark-adapted throughout the session, except for the brief periods of stimulation. A minimum of 2 min in the dark intervened between successive exposures in this experiment.

Results. The results of this experiment are plotted as solid lines in Figs. 3 and 4. The ratio of the threshold ΔL to L is constant from absolute threshold to the highest luminances obtainable with our apparatus. The observed deviations from a constant Weber fraction are well within the experimental error.

The origin of the main plot in Fig. 3 is the absolute threshold for each of the experimental conditions. The absolute threshold for Expt. I,

observer D.O., was determined in the following manner. The main path was blocked and ΔL was presented alone for 4.5 msec at either the top or the bottom disk. A staircase procedure similar to the one described above was used, and the threshold was taken as the median of the last

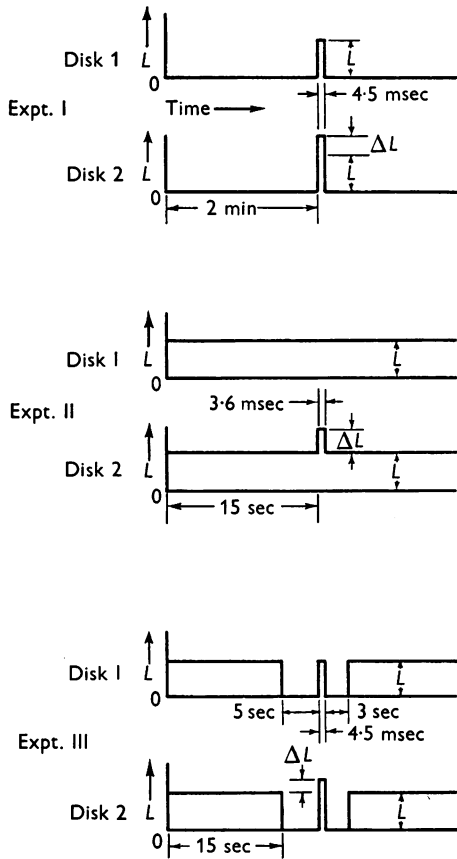

Fig. 2. Temporal sequence of stimuli for each experiment. For the purpose of this diagram, ΔL is always shown as added to disk 2. Throughout the actual experiments, it was added to either of the disks in accordance with a random schedule.

thirty presentations. The geometric mean of two separate determinations is the value of the origin of Fig. 3 for Expt. I. This corresponds to a luminance of 5.6×10^{-4} ft.-lamberts for this observer. It was stated above that this staircase procedure should yield a threshold equivalent to the luminance necessary for 75% correct judgements. That this is true may be seen from the inset in Fig. 3. After the absolute threshold was deter-

mined by the staircase technique, a separate experiment was performed in which a large number of stimuli were presented at a set of levels around this threshold. The stimuli were delivered in a random sequence, according to a constant-stimulus method and the observer judged 'top' or 'bottom'.

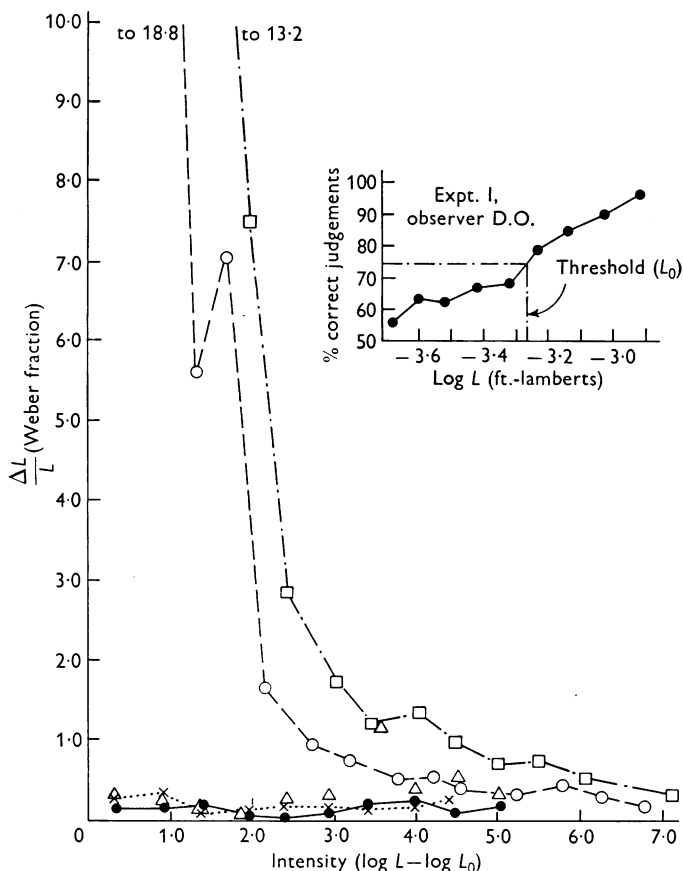

Fig. 3. Absolute threshold data (inset figure) and Weber Fractions for Expts. I, II, and III plotted as a function of the intensity of the base luminance relative to the absolute threshold level (L_0). For observer D.O., Expts. I (●—●) and III (× - - - ×), $L_0 = 5.6 \times 10^{-4}$ ft.-lamberts, and for Expt. II (○—○), $L_0 = 8.4 \times 10^{-6}$ ft.-lamberts. For observer D.D., Expt. I (△, △), $L_0 = 3.0 \times 10^{-4}$ ft.-lamberts and for Expt. II (□—□), $L_0 = 4.5 \times 10^{-6}$ ft.-lamberts.

The results are plotted in the inset to Fig. 3. The luminance level labelled 'threshold' is the level determined by the staircase procedure. It may be seen that this corresponds to the luminance at which the observer is correct approximately 75% of the time in the constant-stimulus experiment. The absolute thresholds reported for observer D.D. were not

measured in this way, but were estimated from frequency of seeing data obtained while the Weber fraction was being measured at the lowest base luminance.

During the determination of a differential threshold, as the probability that the dimmer stimulus (L) will be seen at all becomes appreciably smaller than unity, the Weber fraction ($\Delta L/L$) must begin its rise towards infinity. That rise is trivial in relation to the content of the present report,

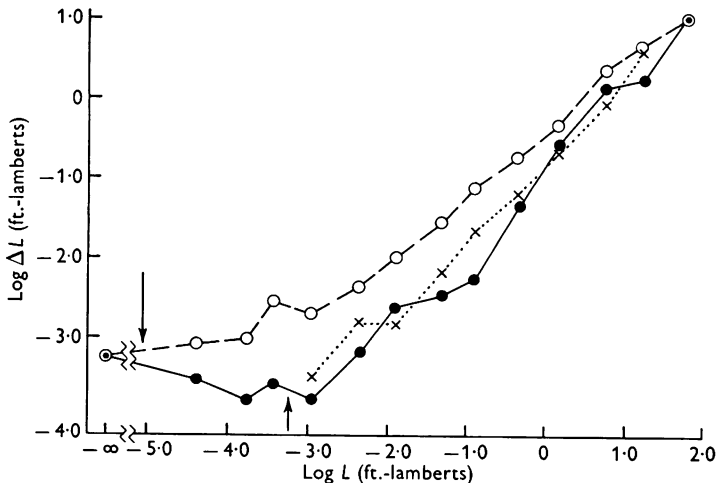

Fig. 4. $\text{Log } \Delta L$ plotted against $\text{log } L$, Expts. I, II, and III. Observer: D.O. Expt. I, ●—●, absolute threshold at arrow; Expt. II, ○—○, absolute threshold at arrow; Expt. III, × ··· ×.

and therefore the lowest level of L for which Weber fractions are plotted in Fig. 3 is one which was detected 95% of the time. This level is about 0.3 log units above the absolute threshold as defined above, i.e. 75% correct (see the inset to Fig. 3). Threshold ΔL 's for base luminances below that level for observer D.O. are included in Fig. 4.

Experiment II

The results of Expt. I are considerably different from most of the luminance discrimination data in the literature. The typical curve of $\Delta L/L$ plotted against L shows large departures from a constant Weber fraction at low luminances (see, e.g. reviews by Barlow, 1957; Pirenne, 1962). The difference between our data and the classical data may have been the result of our psychophysical method, or the result of certain differences in the stimulating conditions. A standard set of conditions under which large departures from a constant Weber fraction have been reported is one in which incremental flashes are superimposed upon a

steadily illuminated field, and the increment required for detection is determined as a function of the steady luminance (e.g. Herrick, 1956). Expt. II was therefore performed, using exactly the same psychophysical procedure and stimulus configuration as in Expt. I. However, it was so designed that the flash to be detected was added to a steadily illuminated field of the same size as the flash.

Procedure. The double shutter was left open throughout this experiment, and the camera shutter was used (see Fig. 1). When the observer was in position, he saw the two disks steadily and equally illuminated. After a count-down, the experimenter operated the camera shutter, adding the light uniformly over one of the two disks for 3·6 msec. The observer judged which of the disks had the added flash. The temporal sequence of the stimuli is shown schematically in the middle diagram of Fig. 2.

Although the observer was initially dark-adapted before a session, he was allowed to become fully adapted to luminance L before the presentation of the incremental stimulus, and care was taken to ensure that he remained fully adapted to this luminance throughout the session. A minimum of 15 sec of fixation preceded each successive presentation in this experiment.

Results. The results of this experiment are plotted as broken lines in Figs. 3 and 4. The Weber fraction becomes very large at low luminances, and drops to a level close to the level of Expt. I for luminances about seven log units above absolute threshold.

The absolute threshold for Expt. II, observer D.O., was determined in the same manner as described above for Expt. I, except the stimulus duration was set at 5 sec. It corresponds to a luminance of $8\cdot4 \times 10^{-6}$ ft.-lamberts. The difference between the absolute thresholds in the two experiments is consistent with the fact that the flash duration in Expt. I was considerably below the critical duration.

The departures from Weber's law found in Expt. II are typical of the results that have often been reported in the literature. Since the psychophysical procedures and the stimulus configuration were identical throughout Expts. I and II, the difference in results must be a consequence of differences in the stimulating conditions.

Experiment III

The clear difference between the results of the two experiments already described might have resulted from either of two differences in the stimulating conditions. First, in Expt. I the observer's retina was fully dark-adapted before the arrival of the flashes, while in Expt. II the incremental flashes were delivered to a retina that was light-adapted to the base luminance level. Thus, any retinal properties that change as a result of

photochemical adaptation might have produced the difference in results. Secondly, in Expt. I the flashes were delivered to a dark retina, while in Expt. II the flashes were delivered to a currently illuminated region of the retina. [It might be said that another difference between the two experiments is that in Expt. I the observer judged which of the two flashed disks had the greater luminance, while in Expt. II he may only have judged which of the two disks *changed* in luminance. In the discussion section this difference will be shown to be irrelevant.] To decide which of these differences in the stimulating conditions accounted for the difference in results, Expt. III was performed using exactly the same psychophysical procedures and stimulus configuration as in Expts. I and II. However, in Expt. III the retina was photochemically adapted to luminance L before each flash, but the flashes were delivered to a dark retina.

Procedure. The temporal sequence of the stimuli is shown schematically in the bottom diagram of Fig. 2. The camera shutter remained open throughout this experiment (see Fig. 1). During the photochemical adaptation phase, the double shutter was open and an opaque 'filter' in F_3 blocked the ΔL from the side path, so that both disks were equally illuminated at L . After the observer fixated the adapting field for 15 sec, the field was darkened for 5 sec during which filter F_3 was changed to the appropriate density. The observer then pressed the key to deliver the flash as in Expt. I. After a brief dark period, during which the judgement was made, the cycle was repeated.

Although the observer was initially dark-adapted before a session, he was allowed to become light-adapted to L before the presentation of the first flash, and he remained photochemically adapted to this luminance throughout the session. The 5 sec dark period before the flash was short enough for very little photochemical dark adaptation to occur (Rushton, 1958), but long enough for most of the neural activity that resulted directly from the light stimulation to cease (Battersby & Wagman, 1959). Thus the stimuli were delivered to a photochemically light-adapted, but dark and relatively inactive retina.

Results. The results of Expt. III are plotted as dotted lines in Figs. 3 and 4. They are virtually identical to the results of Expt. I. Thus the difference between the results of Expts. I and II is clearly not a result of differences in the state of photochemical adaptation of the retina. The fact that the flashes were delivered to an active retina in Expt. II was responsible for the large departure from a constant Weber fraction at low luminances.

DISCUSSION

It is clear that, under the conditions of Expt. I, Weber's law holds perfectly over a very large range of luminances. Several questions of a general nature are raised by this finding. First, what is the importance of the psychophysical method in studies of the Weber function? Secondly, what role do quantal fluctuations play in determining the Weber function? And, finally, what factors might be responsible for the deviations from Weber's law that have customarily been reported?

Psychophysical method. Psychophysical measurements are ones in which an observer makes a set of judgements that are related to a set of stimulating conditions. Implicit in most of the psychophysical literature is the assumption that psychophysical measurements can be used to test physiological theories.

Brindley (1960) has suggested that only when 'Class A observations' are involved can physiological theories be tested rigorously. In Class A observations the observer basically reports whether two stimuli produce the same sensation or different sensations. When Class A observations are used to test physiological theories, the only necessary assumption is that 'physically indistinguishable signals sent from sense organs to the brain cause indistinguishable sensations' (Brindley, 1960, p. 146). If, for example, a theory predicts that two physically different stimuli will produce identical physiological results, and it is shown that an observer can in fact discriminate between them, then the physiological theory has been disproved.

In slightly different terminology, if two stimuli are physically different, and a theory predicts that the information about this difference will be lost in the observer's system, then the theory can be disproved if it is demonstrated that this information is not lost. In a Class A experiment, then, the input is a set of physically definable events and the output is a set of judgements that are expressed as the identity or non-identity of two sensations. One such procedure is to determine by repeated measurements the actual magnitude of the physical difference that is necessary in order to preserve at the output the information that the inputs are different.

However, Brindley does not discuss a point that we believe to be of fundamental importance with regard to the logic underlying Class A experiments. In order for an experiment truly to test discrimination (i.e. to measure unequivocally the observer's information loss) the observer must be told after each judgement whether it was correct or incorrect. If he is not given such feed-back, the amount of information that is lost between the input and the output may depend very strongly upon uncontrolled and poorly understood factors.

For example, in our Expt. I the observer was asked to state which of the two disks had the greater luminance, and he was always told whether his judgements were correct or incorrect. The observers reported that at high base luminances, when the two disks were just different enough to be judged correctly, the disk with the greater luminance actually looked 'brighter'. But, at low base luminances, *correct* judgements could be made at luminance differences for which the two disks did not look different in 'brightness'. It was difficult for the observers to verbalize the basis of the correct judgements, and the difference in luminance would have had to have been considerably greater before a difference in 'brightness' could have been detected. If no feed-back about the correctness of the judgements had been given, the data would have reflected the relation between luminance differences and whatever the observer meant by 'brightness' differences. If one is interested in the subjective aspects of 'brightness' discrimination, it may be desirable to avoid telling the observer whether his judgements are correct or incorrect. However, such a procedure will not allow an evaluation of the physical stimulus difference required for the observer's system to retain the information that there was a difference. The information loss that would be measured in the situation where no feed-back is given would depend upon the observer's criterion of 'brightness'. But when feed-back is given the observer's 'criterion' becomes whatever aspects of his experience are reliably correlated with luminance differences. If he is then unable to discriminate between two different stimuli, it becomes legitimate to assert that his system has really lost the information that they were different.

In our series of experiments the input on each trial contains many bits of information (e.g. that the flash occurred, that two disks were present, that the disks were round, etc.), but we are studying only the transmission of the bit defining the fact that one disk has a greater luminance. The output on each trial contains a single bit of information (i.e. the basis for the binary decision 'top' or 'bottom'). What we determine is the threshold luminance difference, at each of a number of base luminances, that is required for the observer's system to retain the relevant bit. We may thus draw conclusions about the information-transmitting properties of the visual system as a function of the nature of the stimulating conditions.

The statements made above apply equally to each of the experiments in the series. It was mentioned earlier that the judgements in Expt. II might be said to be different from those in Expts. I and III, in that (in Expt. II) the observer may be responding to a *change* in luminance of one of the disks rather than to which of the disks had the greater luminance. Since the above arguments do apply to all three experiments, it should be clear that this apparent difference in the nature of the judgements is not a relevant one.

The question that is then raised by the results of the three experiments is the following: what characteristics of the system itself determine the actual size of the luminance differences necessary to retain the information in the three different stimulating conditions?

Quantal fluctuations. The probabilistic nature of quantal emission sets an absolute lower limit to an observer's ability to judge correctly which one of two disks was set to have the greater luminance. When the apparatus is set to give a series of flashes of a pair of disks at fixed, but different, luminances, the actual numbers of quanta absorbed at the retina in the region of the image of the two disks are not constant from flash to flash. If it is assumed that the observer is a perfect detector and decision maker (i.e. that he always chooses the disk that actually has the greater number of quanta), then some proportion of his judgements will be 'wrong', since sometimes the disk that is set to have the greater luminance will actually deliver fewer quanta.

Any analysis of the role of quantal fluctuations in vision requires special assumptions about the temporal properties of the detecting system. In order to calculate the behaviour of a perfect detector, one must specify the time interval during which it is counting quanta. Previously published studies relating quantal fluctuations to differential thresholds have drawn their conclusions from *incremental* threshold measurements (e.g. Barlow, 1958). For the incremental threshold conditions (as in our Expt. II), it is easy to describe the behaviour of the perfect detector only if one assumes that it begins counting quanta at some time before the added flash is delivered and continues to count for a fixed and known time interval, that interval being long enough to include all the added flash, and having no variance of its own. (The detector then compares that count with some 'standard', for example one that represents the mean number of quanta absorbed during an equally long interval when the increment is absent.) These assumptions seem tenuous when applied to a human observer, as they are, for example, in Barlow's ' τ ' (Barlow, 1957). However, under the conditions of our Expts. I and III (and for absolute threshold measurements), that difficulty is largely overcome. All that is required for the detector to operate correctly is that it open its counting gate at any time during the dark interval before the two disks are flashed and close the gate at any time during the dark interval after the flash. For this reason, the conditions of Expts. I and III lend themselves to a more straight-forward analysis of the role of quantal fluctuations.

If a series of single disks of fixed mean luminance is flashed on the retina, then the distribution of quanta absorbed by the retina in such a series is a Poisson distribution, in which the mean equals the variance. In all cases of interest here, the total number of absorbed quanta is large enough for

the Poisson distribution to approach a normal distribution. If two disks appear in each flash, and if one considers the difference between the numbers of quanta absorbed from each of the disks, then the standard deviation of the distribution of differences in a series of such flashes may be expressed as follows:

$$\text{S.D.}_{\text{diff}} = \sqrt{(\bar{Q}_1 + \bar{Q}_2)},$$

where \bar{Q}_1 and \bar{Q}_2 are the mean numbers of quanta absorbed from the two disks. Since at threshold 75% of the judgements are 'correct' (i.e. they agree with the experimenter's setting of the luminances), the difference between the means of the two disks at threshold may be expressed as follows:

$$\bar{Q}_2 - \bar{Q}_1 = K \sqrt{(\bar{Q}_1 + \bar{Q}_2)},$$

where $K = 0.68$. Solving for \bar{Q}_2 , and keeping only the relevant root, we obtain the following equation:

$$\bar{Q}_2 = \frac{1}{2}[2\bar{Q}_1 + K^2 + K \sqrt{(8\bar{Q}_1 + K^2)}].$$

The absolute threshold for flashes in Expt. I was 5.6×10^{-4} ft.-lamberts, or 685×10^{-4} Trolands. Aguilar & Stiles (1954) derive the following formula for approximating the number of quanta actually absorbed by the retina

$$Q = 4.46 \times 10^5 FAt,$$

where F is the retinal illuminance in Trolands, A is the area of the stimulus in square degrees and t is the flash duration. This calculation yields a value of 96 quanta absorbed by visual pigments at threshold for the flashes in Expt. I. Thus, \bar{Q}_1 is much greater than K , and the equation for \bar{Q}_2 may be simplified as follows:

$$\bar{Q}_2 = \bar{Q}_1 + \frac{1}{2}K \sqrt{(8\bar{Q}_1)}.$$

The Weber fraction may then be expressed as follows:

$$\frac{\bar{Q}_2 - \bar{Q}_1}{\bar{Q}_1} = \frac{K \sqrt{8}}{2} \times \frac{1}{\sqrt{\bar{Q}_1}}.$$

The solid line in Fig. 5 represented the values that the Weber fraction would have, under the conditions of Expt. I, if the observer were a perfect detector and decision maker. The level of the Weber fraction actually observed is plotted as a dashed line in the same figure. The theoretical limit is considerably below the observed value. Further, the quantal limit curve is not horizontal. If luminance discrimination in this situation had been determined by quantal fluctuations, then the Weber fraction would not have been constant but would have decreased as the base luminance increased. It is therefore reasonable to conclude that, under the conditions of Expt. I, quantal fluctuations play a completely negligible role

in determining the Weber function. The above arguments apply equally well to the conditions of Expt. III.

Several discussions of the possible role of quantal fluctuations in determining *incremental* thresholds (as in our Expt. II) have already been published. Aguilar & Stiles (1954) present evidence that quantal fluctuations play no significant role in determining incremental thresholds, while Barlow (1957, 1958) takes the opposite point of view. Although, as we

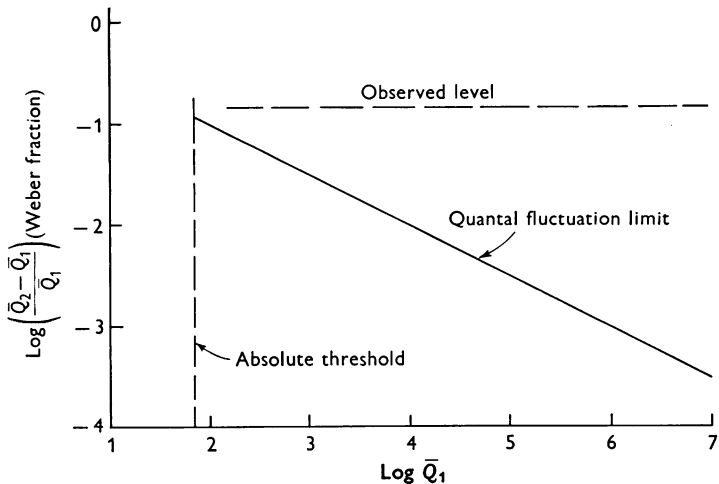

Fig. 5. Comparison of Weber function obtained in Expt. I, observer D.O., with the limit set by quantal fluctuations. D.D.'s observed level is still higher. Explanation in text.

pointed out above, each of these analyses is based on a tenuous set of assumptions about the interval over which quanta might be counted, we are persuaded by Aguilar and Stiles' paper, and therefore conclude that quantal fluctuations are not important in any of the differential threshold determinations we have made.

Physiological speculations. Up to this point we have shown that (1) Weber's law holds perfectly when the flashes are delivered to an inactive retina, regardless of its state of photochemical adaptation, and (2) Weber's law breaks down when the flashes are added to an already active retina. We have also argued that our psychophysical procedures allow for an adequate estimate of information loss that is comparable for the three experiments, and that quantal fluctuations will not account for our findings. In this final section we shall briefly speculate upon some possible characteristics of the visual system that may account for the fact that Weber's law holds under the conditions of Expts. I and III, and breaks down under the conditions of Expt. II.

The fact that the Weber fraction is constant under the conditions of Expt. I can be restated by saying that the visual system acts as if it extracts the ratio of the outputs of the two disks on each flash, and if that ratio exceeds some threshold value, the judgement is correct. In Expt. I the observer's visual system was in the same state before each flash regardless of the level of L , since he was completely dark-adapted between each flash. Therefore it is reasonable to suppose that the threshold for the value of this ratio was always the same. [For example, suppose the threshold, defined as a fixed level of information loss, i.e. 75% correct judgements, is determined by the noise level of the system. Since the observer was dark-adapted before each flash, the noise level was the same before each flash, and therefore the magnitude of the ratio of the outputs was the same at threshold regardless of the level of L .]

It is not easy to imagine a neural circuit that extracts ratios directly. However, there are two lines of evidence that suggest how this same effect might be achieved indirectly in the visual system. The initial photochemical stage (i.e. the absorption of light quanta) is certainly linear over the range of intensities used in the present experiments. However, there is considerable evidence that some of the physiological responses of the retina are logarithmically related to the intensity of the photic stimulus (e.g. Hartline & Graham, 1932; Rushton, 1961). There is also much evidence that neural circuits which extract algebraic differences are common in the nervous system (e.g. Hartline & Ratliff, 1957, for the eye of *Limulus*). In fact, it is probably true that any simple inhibitory circuit has as its output the difference between its excitatory and its inhibitory inputs.

If two inputs are in a constant ratio, the difference between their logarithms is constant. If the visual system first makes a logarithmic transformation of the inputs from each of the disks, and if the difference between these transformed outputs exceeds the threshold for a difference circuit (that threshold being the same at each flash), then a constant Weber fraction would result.

On the basis of this model, some conclusions may be drawn from the relationships among the results of our three experiments. First, the fact that Expts. I and III yield identical results suggests that the state of photochemical adaptation has no important effect on the state of the difference circuit. Secondly, the difference between the results of Expts. I and III, on the one hand, and Expt. II, on the other, might be explained by either of two possibilities. Under the latter conditions, the initial logarithmic transformation of an increment might be disturbed when the retina is active just before the flash, becoming more linear at low levels of activity. Or the operation of the difference circuit might be affected by the presence

of a steady input. Although we know of no direct evidence against the first of these possibilities, we believe that the second is more likely (i.e. it seems quite reasonable that the operation of a difference circuit of this sort would be affected by the ambient input level). The following is a discussion of one way in which its operation might be affected.

The data of Expt. II indicate that the visual system loses more information about differences in number of quanta at low luminances when such information is delivered to a retina that is already active. Further, the relative amount of information loss becomes smaller as the steady base luminance becomes greater. The flash duration was always approximately 4 msec in these experiments. It is certainly true that the output of the retina does not follow instantaneous changes in quantal input. It depends, instead, upon a running integral of the input over time. When the flashes are delivered to an inactive retina (as in Expts. I and III) the length of the integration time is irrelevant, as long as it is at least as long as the flash duration. That is, the difference between the outputs of the two disks would be the same whether the system compares them over 4 or over 8 msec. It is also clear that the integration time could not change as a function of the base luminance under these conditions.

However, under the conditions of Expt. II the same arguments probably do not apply. Here the retina has been steadily active for a period of time, at a level determined by the base luminance. Under conditions of this sort, it has been shown (e.g. Graham & Kemp, 1938; Herrick, 1956; Barlow, 1958) that temporal summation is reduced when the base luminance is increased. If the input from each disk were integrated over 8 msec, for example, the ratio of the number of quanta in the two disks *during that time* would have been smaller than if the integration time were 4 msec. It would then follow that the difference in outputs from the two disks would be smaller when the integration time is longer, and a larger ratio of luminances would be required for reliable discrimination.

If it is true that the only relevant change as a function of L is a change in integration time, then the data of Expt. II may be used to derive values for the integration time by means of the following formula:

$$IT_L = \frac{t[\Delta L/L]_{II}}{[\Delta L/L]_I},$$

where IT_L is the integration time at each L ; t is the flash duration; $[\Delta L/L]_I$ is the value of the Weber fraction for Expt. I (smoothed curve); and $[\Delta L/L]_{II}$ is the value of the Weber fraction at each L for Expt. II (smoothed curve). These derived values for the integration time are plotted in Fig. 6.

Several other investigators (e.g. Graham & Kemp, 1938; Herrick, 1956)

have shown that the critical duration decreases as the base luminance increases. Their experimental conditions and methods for deriving indices of temporal summation are different from ours, and this precludes a direct comparison of results.

One clear-cut prediction may be made if the preceding speculations are valid. If the incremental threshold is measured as in Expt. II but the flash duration is varied so as to compensate for the hypothetical changes in integration time represented in Fig. 6, one should be able to generate a constant Weber fraction.

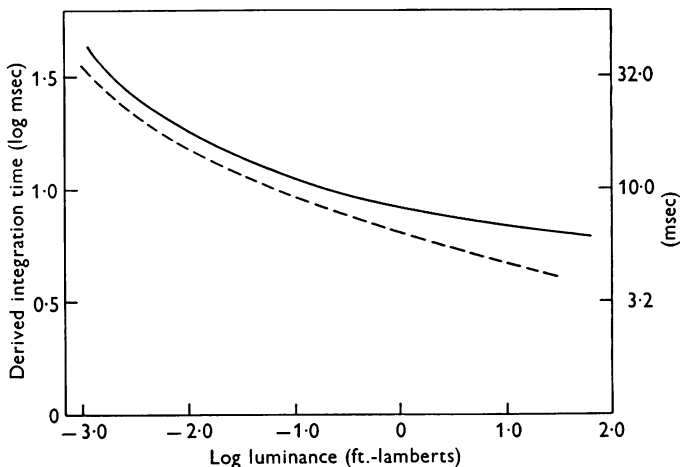

Fig. 6. Integration time as a function of base luminance, under the conditions of Expt. II. The curves are derived from the theoretical considerations presented in the text. Solid curve for D.O., interrupted curve for D.D.

SUMMARY

1. Human observers were trained to discriminate differences in luminance between two simultaneously presented disks of light. The disks were each 50 minutes in diameter, and their centres were one degree above and one degree below a fixation point. After each exposure, the observer was told whether or not he had judged correctly.

2. When the eye was completely dark-adapted before each flash, and the disks were flashed for 4.5 msec, the Weber fraction was found to be constant over a range of luminances from just above the absolute threshold to approximately five log units above absolute threshold. Higher luminances were not tested.

3. When the relevant region of the retina was completely light-adapted to the base luminance before each flash, but the adapting field (of the same size as the stimulus) was turned off 5 sec before the disks were flashed for

4.5 msec, the Weber fraction was again found to be constant and at the same value as in (2) above, over the same range of luminances.

4. When the relevant region of the retina was completely light-adapted to the base luminance before each flash, but the flash was presented for 3.6 msec as an *increment* to one of the already lighted disks, the Weber fraction was found to be very large at low base luminances and to decrease to a level close to the levels in (2) and (3) above at high base luminances.

5. The results of these experiments are discussed in terms of the psychophysical procedures, and the possible role of quantal fluctuations is considered. The suggestion is made that departures from Weber's law may be attributable to changes in the integration time of the visual system.

This investigation was supported by a PHS research grant, NB 03412, from the Institute of Neurological Diseases and Blindness, U.S. Public Health Service.

REFERENCES

- AGUILAR, M. & STILES, W. S. (1954). Saturation of the rod mechanism of the retina at high levels of stimulation. *Optica Acta*, **1**, 59-65.
- BARLOW, H. B. (1957). Increment thresholds at low intensities considered as signal/noise discriminations. *J. Physiol.* **136**, 469-488.
- BARLOW, H. B. (1958). Temporal and spatial summation in human vision at different background intensities. *J. Physiol.* **141**, 337-350.
- BATTERSBY, W. S. & WAGMAN, I. H. (1959). Neural limitation of visual excitability. I. The time course of monocular light adaptation. *J. opt. Soc. Amer.* **49**, 752-759.
- BRINDLEY, G. S. (1960). *Physiology of the Retina and Visual Pathway*. London: Edward Arnold.
- CORNSWEET, T. N. (1962). The staircase-method in psychophysics. *Amer. J. Psychol.* **75**, 485-491.
- GRAHAM, C. H. & KEMP, E. H. (1938). Brightness discrimination as a function of the duration of the increment in intensity. *J. gen. Physiol.* **21**, 635-650.
- HARTLINE, H. K. & GRAHAM, C. H. (1932). Nerve impulses from single receptors in the eye. *J. cell. comp. Physiol.* **1**, 277-295.
- HARTLINE, H. K. & RATLIFF, F. (1957). Inhibitory interaction of receptor units in the eye of *Limulus*. *J. gen. Physiol.* **40**, 357-376.
- HEINEMANN, E. G. (1961). The relation of apparent brightness to the threshold for difference in luminance. *J. exp. Psychol.* **61**, 389-399.
- HERRICK, R. M. (1956). Foveal luminance discrimination as a function of the duration of the decrement or increment in luminance. *J. comp. physiol. Psychol.* **49**, 437-443.
- PIRENNE, M. H. (1962). Liminal brightness increments. In *The Eye*, pp. 159-173, ed. DAVSON, H. London and New York: Academic Press.
- RUSHTON, W. A. H. (1958). Kinetics of cone pigments measured objectively on the living human fovea. *Ann. N.Y. Acad. Sci.* **74**, 291-304.
- RUSHTON, W. A. H. (1961). Peripheral coding in the nervous system. In *Sensory Communication*, pp. 169-181, ed. ROSENBLITH, W. A. New York: John Wiley.