

Lawrence Berkeley National Laboratory

Lawrence Berkeley National Laboratory

Title

EXPERIMENTAL PROBLEMS IN THE USE OF A POLARIZED PROTON TARGET

Permalink

<https://escholarship.org/uc/item/1gs81115>

Author

Chamberlain, Owen

Publication Date

2008-06-20

UCRL-17133

University of California
Ernest O. Lawrence
Radiation Laboratory

EXPERIMENTAL PROBLEMS IN THE USE
OF A POLARIZED PROTON TARGET

TWO-WEEK LOAN COPY

*This is a Library Circulating Copy
which may be borrowed for two weeks.
For a personal retention copy, call
Tech. Info. Division, Ext. 5545*

Berkeley, California

1966 International Conference on
Instrumentation for High Energy Physics
SLAC, September 9-10, 1966.

UCRL-17133

UNIVERSITY OF CALIFORNIA
Lawrence Radiation Laboratory
Berkeley, California

AEC Contract No. W-7405-eng-48

EXPERIMENTAL PROBLEMS IN THE USE OF
A POLARIZED PROTON TARGET

Owen Chamberlain

September 9, 1966

(UCRL 17133)

EXPERIMENTAL PROBLEMS IN THE USE OF A POLARIZED PROTON TARGET

Owen Chamberlain

September 9, 1966

I have understood my assignment as a review of some of the work done in high-energy physics with polarized proton targets and a description of some of the special problems connected with polarized targets.

Most of my report will be based on the polarized target that I am most familiar with -- that constructed by Jeffries, Schultz, Shapiro, and myself. This target is no longer unique; in fact, it is now somewhat old-fashioned in some respects. Other polarized proton targets are in operation at CERN, Saclay, the Rutherford Laboratory, Argonne National Laboratory, the Soviet Union, and there is a target newly in operation at the Brookhaven Laboratory. Other targets are in operation or are in the process of design or construction at a number of other places.

Unfortunately, none of these targets consists of pure hydrogen. The target material most often used is made of lanthanum magnesium nitrate, LMN. About a quarter of the weight of this crystal is water; it is the protons within the water molecules that are polarized. Hydrogen constitutes only 3 percent of the weight of the crystal. This means that scattering processes on hydrogen must be distinguished kinematically from scattering processes involving the heavy elements of the target if the target is to be used efficiently in high-energy scattering experiments. In fact, some of the experiments one would very much like to do appear to be very difficult.

In LMN the protons are polarized by an indirect process known as dynamic

polarization. Neodymium ions are added to the crystal when it is grown from a water solution. The neodymium ions are substituted for lanthanum to the extent of one percent or less. The neodymium ion has an odd number of electrons; it has a doublet ground state, called a Kramers doublet, that acts very much like a single free electron as far as its spin is concerned, but anchored in space to a particular lattice site. When the crystal is properly oriented in a magnetic field it has a g factor that is about 1.3 times as great as that of a free electron. I will refer to these neodymium ions as "electrons."

The crystal is placed in a magnetic field, 18 kilogauss in our case, and is held at low temperature by a bath of liquid helium constantly being pumped on to maintain a temperature of about one degree Kelvin. Because of the low temperature and the high magnetic field the electrons are highly polarized, as may be calculated using the Boltzmann factor. In our target the electrons are polarized to the extent of 88 percent. Because the magnetic moment of the proton is so small, the protons are polarized only to the extent of 0.15 percent -- too little to be useful. However, the protons can be polarized to an extent comparable to that of the electrons if we use a trick developed by Jeffries and by Abragam, sometimes referred to as the solid effect.

The trick consists in irradiating the sample with microwaves of a frequency chosen to cause a particular transition. One starts with a Boltzmann distribution of states in the crystal but then selectively disturbs this Boltzmann distribution to accomplish the desired result.

Fig. 1 helps to portray the situation. Imagine that we have one electron and one proton, side-by-side. There are four possible states of this system corresponding to the spin orientation (spin up or spin down) of each of the particles. Because the magnetic moment of the electron is much larger, the

energy level diagram looks as shown. Note, however, that the large spacing Δ should be about 1000 times greater than the small spacing δ . At thermal equilibrium at one degree the lower two states are the most probable; the electron is highly polarized and the proton is hardly polarized at all. Now we turn on the microwaves at such a frequency that we induce the forbidden transition, in which both the electron and the proton have their spin reversed when a photon is absorbed. There are two such transitions -- one causes positive proton polarization (that is, in the same direction as the thermal-equilibrium polarization) and the other causes negative proton polarization.

It is not necessary to go through the arithmetic, but in the limit that the microwaves may be considered intense enough to completely saturate the forbidden transition one can, in principle, obtain proton polarizations that are numerically equal to the initial polarization of the electrons. In other words, we have an upper limit of 88 percent for this method of polarizing our protons under these circumstances. In practice we have reliably measured proton polarizations of 65 percent, and we have carried out experiments in which the average polarization over many weeks of operation was 50 percent. The French group, involving Abragam and Roubeau, reports that they achieve 72 percent, and run for long periods with over 65 percent proton polarization.

In order to measure the proton polarization we measure the signal size in a normal nuclear-magnetic-resonance (NMR) detector. In fact, we integrate the signal size over a band of frequencies containing the proton resonance in order to get a number which is proportional to the proton polarization. Since it is difficult to calibrate the gain of the detection system in absolute terms, we use the thermal-equilibrium polarization (observable when the microwaves are not present) as a known polarization with which the system can be calibrated. We may put this in other terms by saying that we calculate the thermal-equilibrium

polarization from the Boltzmann factor and then multiply this by the observed enhancement of polarization to determine the degree of polarization while the microwaves are turned on.

Our target is of the simplest possible construction, and it is therefore somewhat reasonable to use it for the purposes of illustration. The desired homogeneity of magnetic field (1 gauss uniformity in 18,000 gauss) was achieved by the simple expedient of making large iron poles quite flat and plane. A more sophisticated design has been used by Abragam, Borghini, Roubeau, and Ryter, as shown in Fig. 2; this design uses shaped poles made of a high-flux cobalt alloy to achieve good homogeneity and at the same time maintain a rather open structure for counting out-going particles over a large solid angle. This figure also shows the (horizontal) cryostat with the liquid-helium dewar close by. This is a very beautiful method of construction, though I believe there are some subtle design problems associated with the behavior of liquid helium II so I would advise someone who was starting a new polarized target construction either to use a simpler construction or to start with an exact copy of the French target.

Our own target is extremely simple in that the liquid helium system is really just an ordinary dewar. This dewar is filled in batches of about 20 liters, about once each four hours during operation. The pumping on the liquid helium system to keep the temperature as low as 1 degree is accomplished by two Roots blowers backed up by a large Kinney pump.

Now I would like to avoid combing over details of the target construction and restrict my attention for the moment to those special properties of polarized proton targets that tend to limit their usefulness or give rise to the need for special techniques.

As we have said earlier, the usual target material, LMN, contains only 3

percent by weight of hydrogen, so it is nearly essential to use some kinematic method of distinguishing the scattering processes on free hydrogen from those occurring in heavy nuclei. The most commonly used method is illustrated in Fig. 3. The beam is shown incident from the left upon the crystals of LMN located at the center of the magnet. Elastic scattering of beam particles upon protons can be distinguished by selecting events in which two charged particles emerge from the target that are coplanar with the incident beam and that also have the expected correlation between the exit angles that is expected for elastic scattering on hydrogen. This method would typically be used for measurements of polarization in elastic π^+ -p, π^- -p, or p-p scattering. In the simple arrangement shown in Fig. 3 there are 10 upper counters, U_1 to U_{10} , each of which may count in coincidence with any of the 10 down-array counters, D_1 to D_{10} . (The other counters shown are used to select possible interesting events, but may be ignored in the present discussion.) This counter system counts only coplanar events because the common plane containing the U and D counters also contains the beam. We may select from the coincidence events those that correspond to the kinematics for elastic scattering on hydrogen as may be shown with the help of Fig. 4. Here coincidence events involving the upper counter U_6 are shown for various down counters. The peak in number of counts in counters D_3 and D_4 is due to scattering ^{on} protons, while the lower region is due to scattering on complex nuclei, as determined by taking counts while the LMN crystals are replaced by a dummy target containing similar elements but in which there is no hydrogen. In the region of the hydrogen peak you will notice there are two histograms superimposed. One of these corresponds to one direction of target polarization and the other to the opposite direction of polarization. The difference in counting rates for the two directions of target polarization constitutes the asymmetry to be measured. Notice that in the region of the

hydrogen peak these counts are about 75 percent due to hydrogen and 25 percent due to background from heavy elements or possibly from processes other than elastic scattering. These numbers are fairly typical, though when we attempt to make measurements at angles where the elastic cross section is very small the hydrogen peak may not stand out at all well over the background. We have been able to make measurements whenever the elastic differential cross section is at least 100 microbarns per steradian in the cm system.

I should say that we presently use a more complicated system than the one I have shown. The upper counter array, instead of being just one row of ten counters, is a double array of crossed counters, 30 counters by 10 counters. Similarly the lower counter array is 30 counters by 6 counters. With these more elaborate arrays the total system involves about 100 counters and the events are recorded with the help of a small on-line computer (PDP-5). The computer is used mainly as a data-handling device -- it is not used to calculate differential cross sections or polarizations. The purpose of the computer is to record the events, about 100 at a time, on magnetic tape. The computer also serves to display information ^{such as} ~~like~~ that shown ^{in Fig. 4} ~~on the last slide~~ so that we may be reassured that the system is working normally.

The system just described is limited to scattering angles that give a recoiling proton of sufficient range to be counted in the lower array of counters. This usually means that the recoiling proton must have at least 350 MeV/c momentum in the laboratory frame.

It is possible to make measurements at smaller angles, but a different system must be used. In principle it should be possible to distinguish elastic scattering on hydrogen by observing the correlation of momentum with angle for the outgoing (beam) particle. This allows only a one-constraint fit for scattering on hydrogen, and the background tends to be larger. Fig. 5 shows

the result of attempting this by looking at the differential range spectrum of particles (250 MeV pions) scattered at a small angle. The two curves show the results for target crystals and for dummy target, the difference showing the elastic scattering on the hydrogen in the crystals. However, notice that the counting rate at the hydrogen peak is only 20 percent due to hydrogen, the remainder being background. This greatly limits the accuracy with which a hydrogen asymmetry can be determined.

As another example of a one-constraint fit, Fig. 6 shows the result of attempting to distinguish the reaction $\pi^+p \rightarrow K^+\Sigma^+$. The hydrogen peak is evident, but the counting rate at the hydrogen peak is only half due to hydrogen even though the target is in this case CH_2 . The background is several times worse when the LMN target is used.

At the Stony Brook conference Sonderegger described a measurement of polarization in π^-p charge-exchange scattering in which the charge-exchange process on hydrogen at small angles was recognized by the relatively slow neutron produced. The gamma rays from the π^0 were also observed in spark chambers. This method promises to be quite important in the next few years.

There seems to be no reason that n-p polarization experiments cannot be fairly readily done with existing polarized targets, particularly if the incident neutron energy can be known well, possibly by a time-of-flight technique.

We have used the polarized target for a measurement of C_{nn} in p-p scattering. In this case a polarized proton beam is incident on the polarized proton target. A double difference must be taken between four observed counting rates to measure this quantity, which distinguishes scattering with parallel proton spins from scattering with spins antiparallel.

By combining techniques that are already perfectly well known we should be able to do experiments in which we start with a polarized proton as target,

make a scattering process, and then investigate the polarization state of the recoiling proton after the scattering. This involves rescattering the recoil proton, but, of course, this has been done in many experiments. It is somewhat harder when the first target is a polarized proton target because the polarized target is usually somewhat smaller in hydrogen content than the targets previously used. I understand that the physicists at Saclay are now preparing to do just such an experiment. They will be measuring the Wolfenstein parameters R and A for π -p scattering. To facilitate these measurements it is important to have a different magnet geometry than has usually been used. Helmholtz coils, probably superconducting, seem most suitable.

At the present time there are a number of difficulties with polarized target experiments.

1. Hydrogen events must be separated from heavy-nucleus events, as already described.
2. Existing targets tend to be rather thick when measured in radiation lengths. One inch of LMN constitutes about one-fifth of a radiation length. This means multiple scattering is bad and electron experiments are extremely difficult.
3. The LMN target is easily damaged by radiation. A dose of 10^{12} protons per square centimeter reduces the polarization to about half its previous value. This is not intolerable for strong scattering processes but makes electron experiments extremely hard.
4. Proton polarization need not be the same in all parts of the sample, either because of non-uniform microwave density or because of radiation damage or local heating of the crystals. .
In principle this need cause no error but in practice it is

hard to arrange completely uniform irradiation of the target crystals by the incident beam. For the same reason care must usually be taken to assure that the NMR system is equally sensitive to all parts of the target crystals.

5. Most experiments suffer because the absolute degree of target polarization is uncertain by about 10 percent. Present methods should allow 5 percent accuracy but great care is needed to achieve this routinely.
6. Our present target requires a 15-minute delay each time the polarization direction is reversed. Since every experiment requires a comparison of counting rates with the two directions of polarization this represents an important loss of effectiveness when the direction is reversed once every two hours.
7. An experiment with a polarized target is rather like two experiments being carried on at once. At least one extra man is required to operate the target.

There is promise that some of these difficulties can be ameliorated in the near future.

Targets with higher concentration of hydrogen are known to be possible. Wagner and Haddock have recently reported that 30 percent polarization can consistently be had in a frozen toluene target suitably doped. This is very promising, particularly for certain experiments that are presently limited by the allowable thickness of the target as measured in radiation lengths. Furthermore, hydrocarbon targets may, according to Carson Jeffries, be many times less sensitive to radiation.

Methods exist that should allow the direction of polarization to be

reversed in a fraction of a second. Either "adiabatic fast passage" through the proton resonance or a 180-degree pulse of rf should do the job, as in the Hahn method of spin echoes.

Several new approaches to polarized targets seem to be on the horizon. Jeffries has made a spin refrigerator. It works rather like a Carnot engine. The direction of the field is periodically altered with respect to the crystal axes. This modulates the g factor of the electrons and hence the electron temperature in much the same way that a gas temperature can be modulated within a cylinder with piston. This development promises to remove the stringent requirements on constancy of magnetic field in space and in time.

I suppose brute force methods may eventually be fairly good. New He³-He⁴ dilution refrigerators work to 0.1 degree. This temperature, if maintained in a field of 100 kilogauss, would give 10 percent proton polarization at thermal equilibrium. The sample might be LiH, but probably not H₂, because of the ortho-para complications.

It seems that we should expect that new sample materials will be developed that will improve current methods, and new methods are clearly being developed. In the near future much better polarized targets should be in use for a variety of experiments.

FIGURE CAPTIONS

Fig. 1. Energy level diagram for a system composed of one proton and one "electron." The level spacings are not drawn to scale.

Fig. 2. The polarized proton target of Abragam, Borghini, Roubeau, and Ryter, with horizontal cryostat and rather open magnet construction. This target can operate continuously as long as the liquid helium lasts in the dewar.

Fig. 3. Experimental arrangement used by Grannis et al. to distinguish elastic scattering on hydrogen from other scattering processes occurring in the polarized proton target. U_0 and D_0 are "over-lay" counters that cover the counters numbered 1 through 10. D_d is a counter close to the target. C is a Cherenkov counter.

Fig. 4. Coincidence counts between the up-array counter U_6 and various down-array counters. The peak in counters D_3 and D_4 is due to elastic scattering on protons.

Fig. 5. Counting rate in a differential range telescope as a function of copper absorber thickness when low-energy charged pions are detected at a small angle to the beam. The solid curve follows points taken with the regular target crystals, the dotted curve with a dummy target; the difference is due to hydrogen.

Fig. 6. Detection of the process $\pi^+ p \rightarrow K^+ \Sigma^+$ by observing the range and exit angle of K^+ mesons from a CH_2 target. The heavy-element background is large even in CH_2 ; it is even worse for a target of LMN.

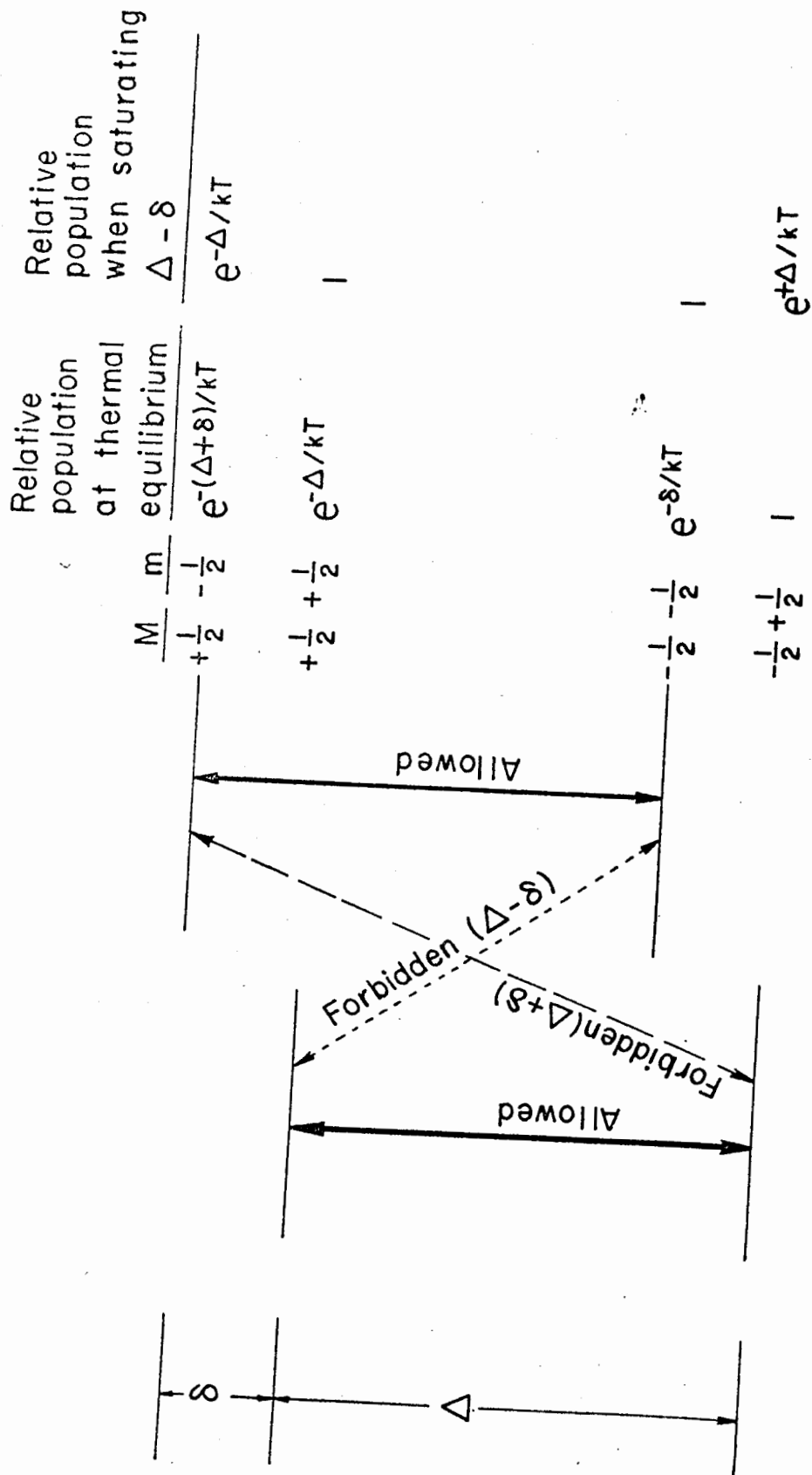

MU-32843

Fig. 1

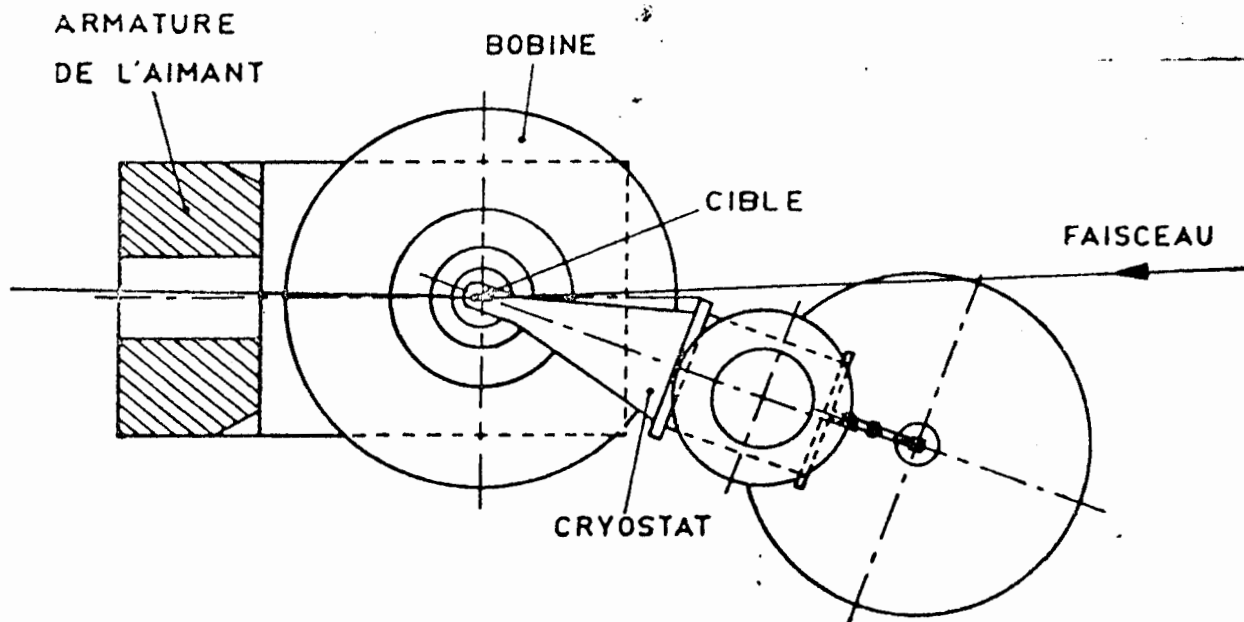
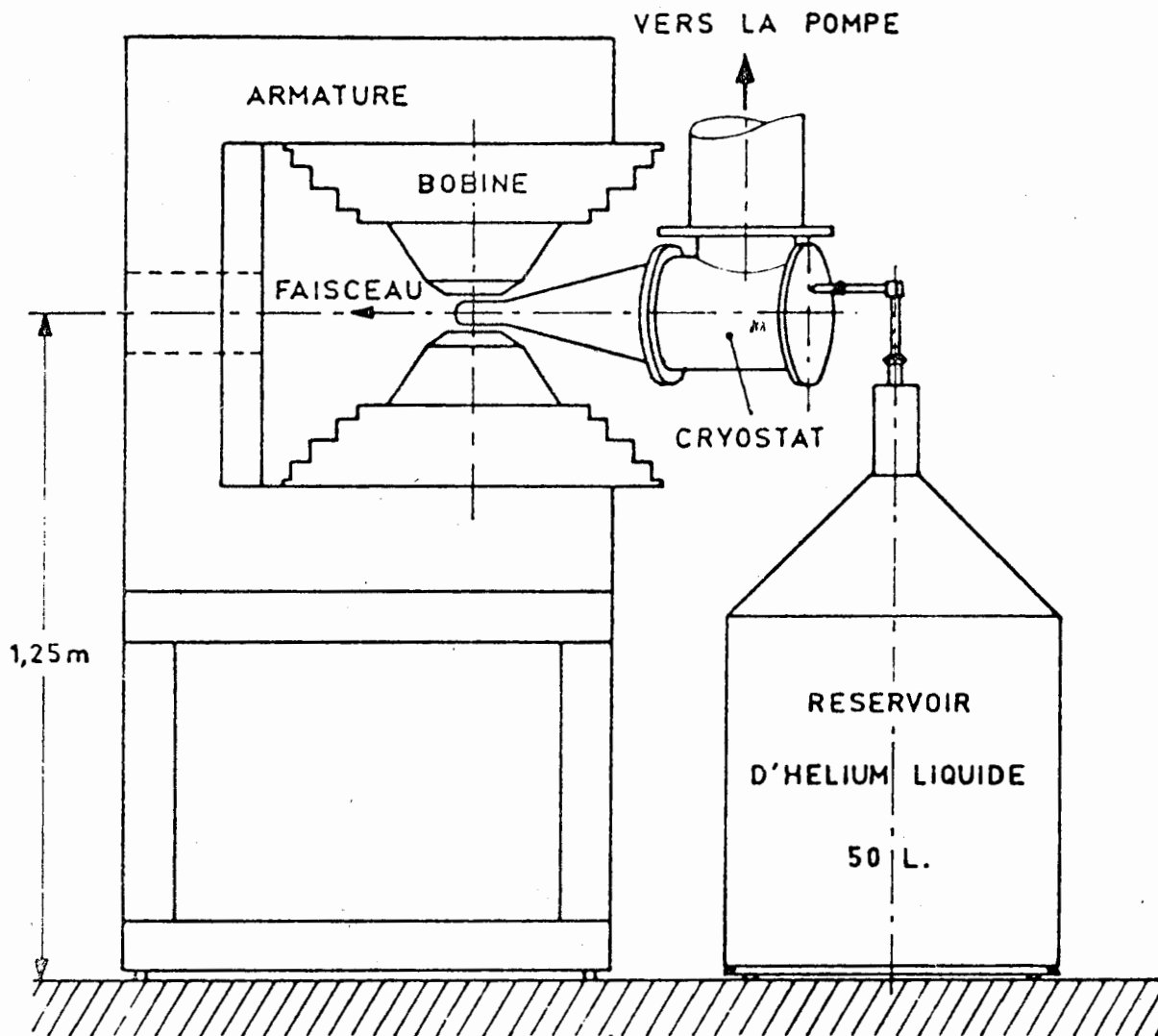
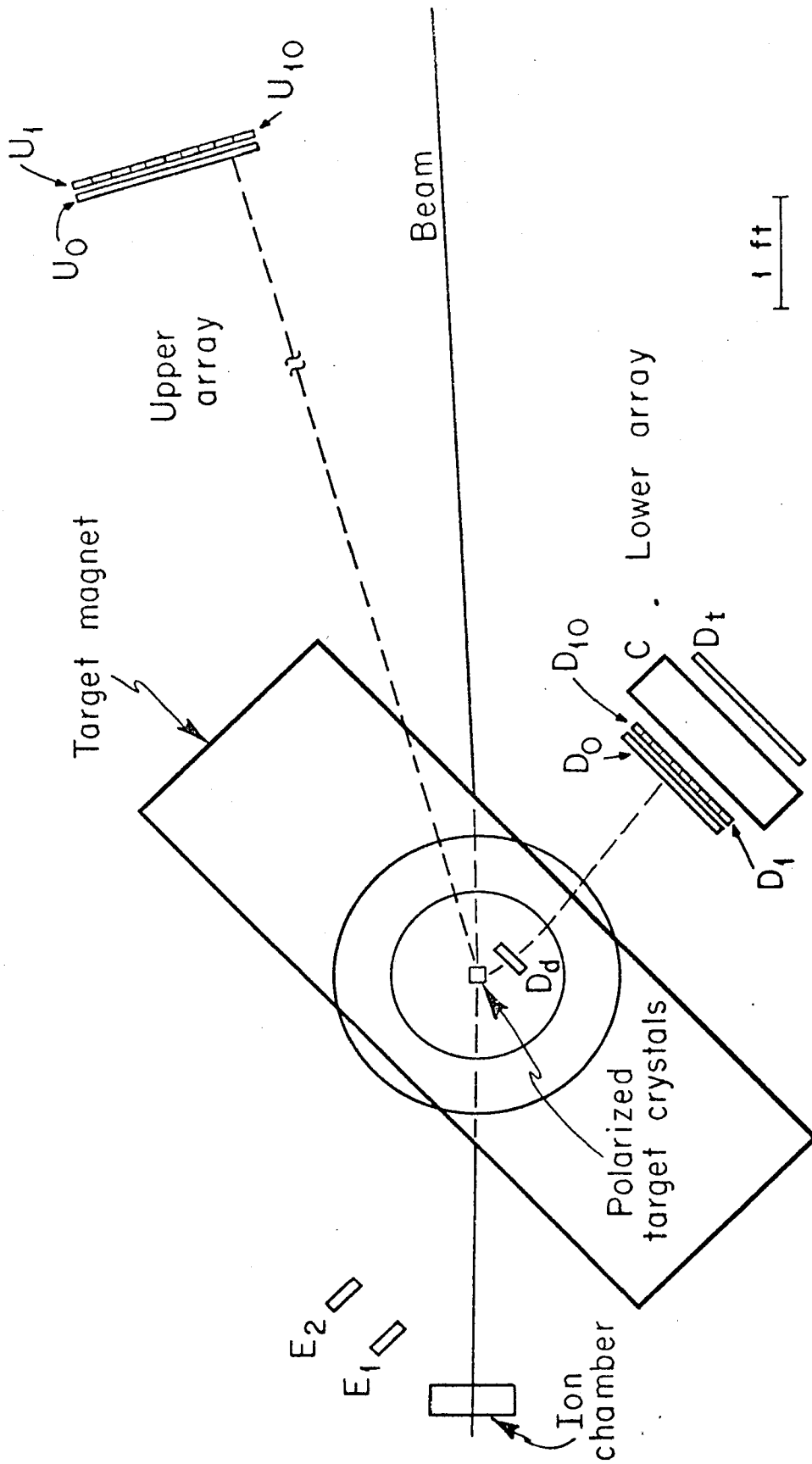

Fig. 2



MU-35856

Fig. 3

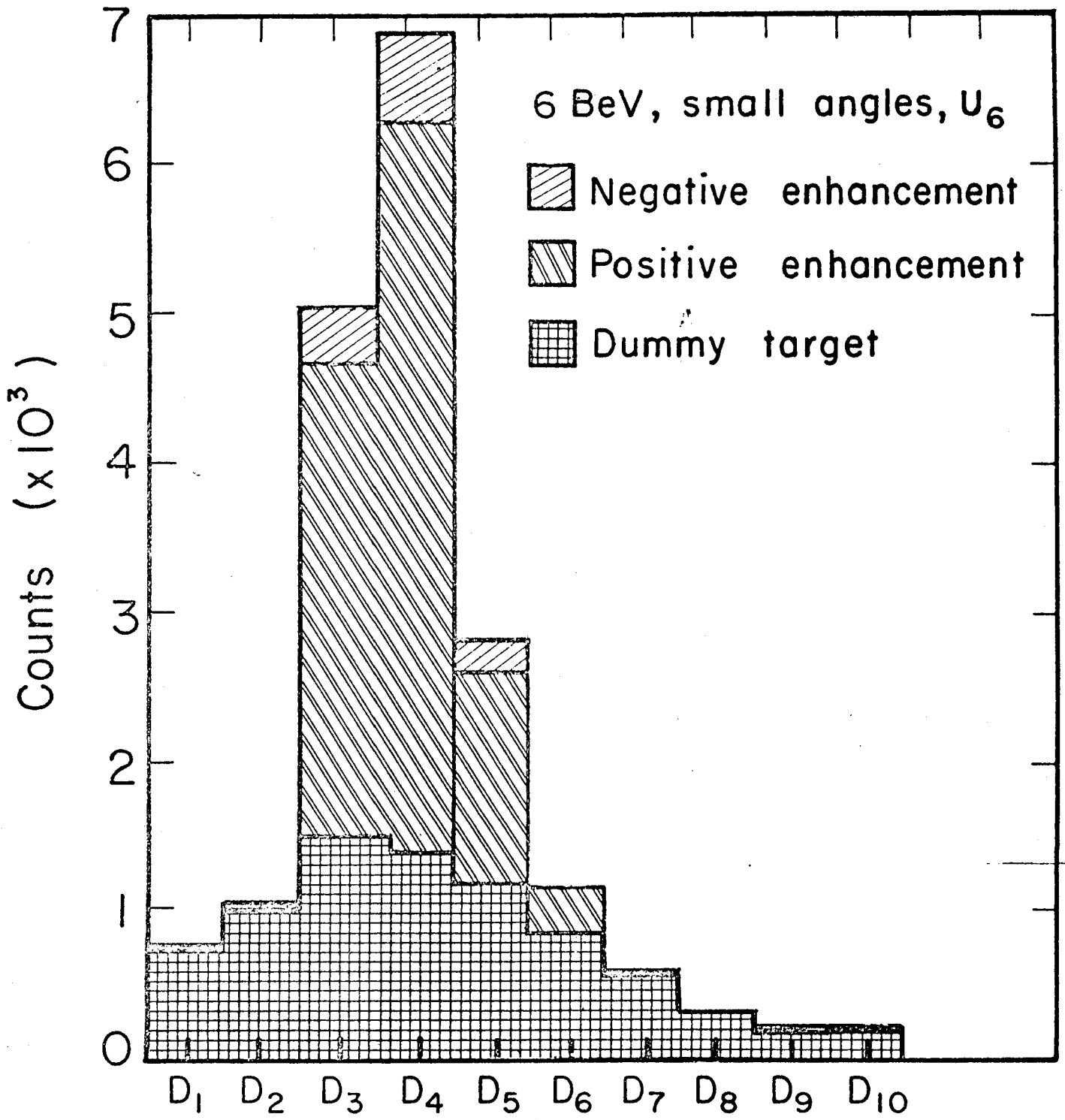

Fig. 4

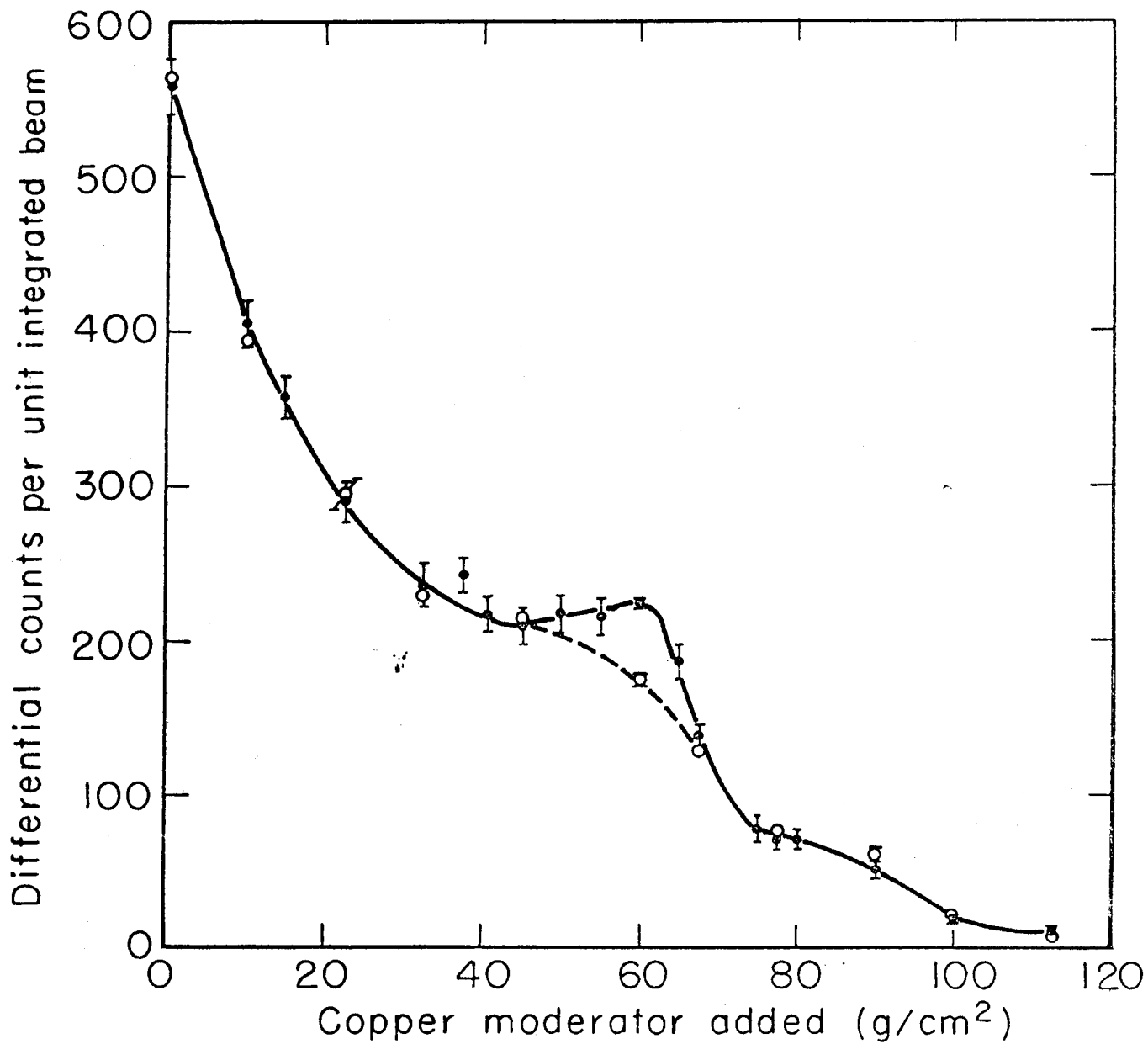

Fig. 5

MU-29815A

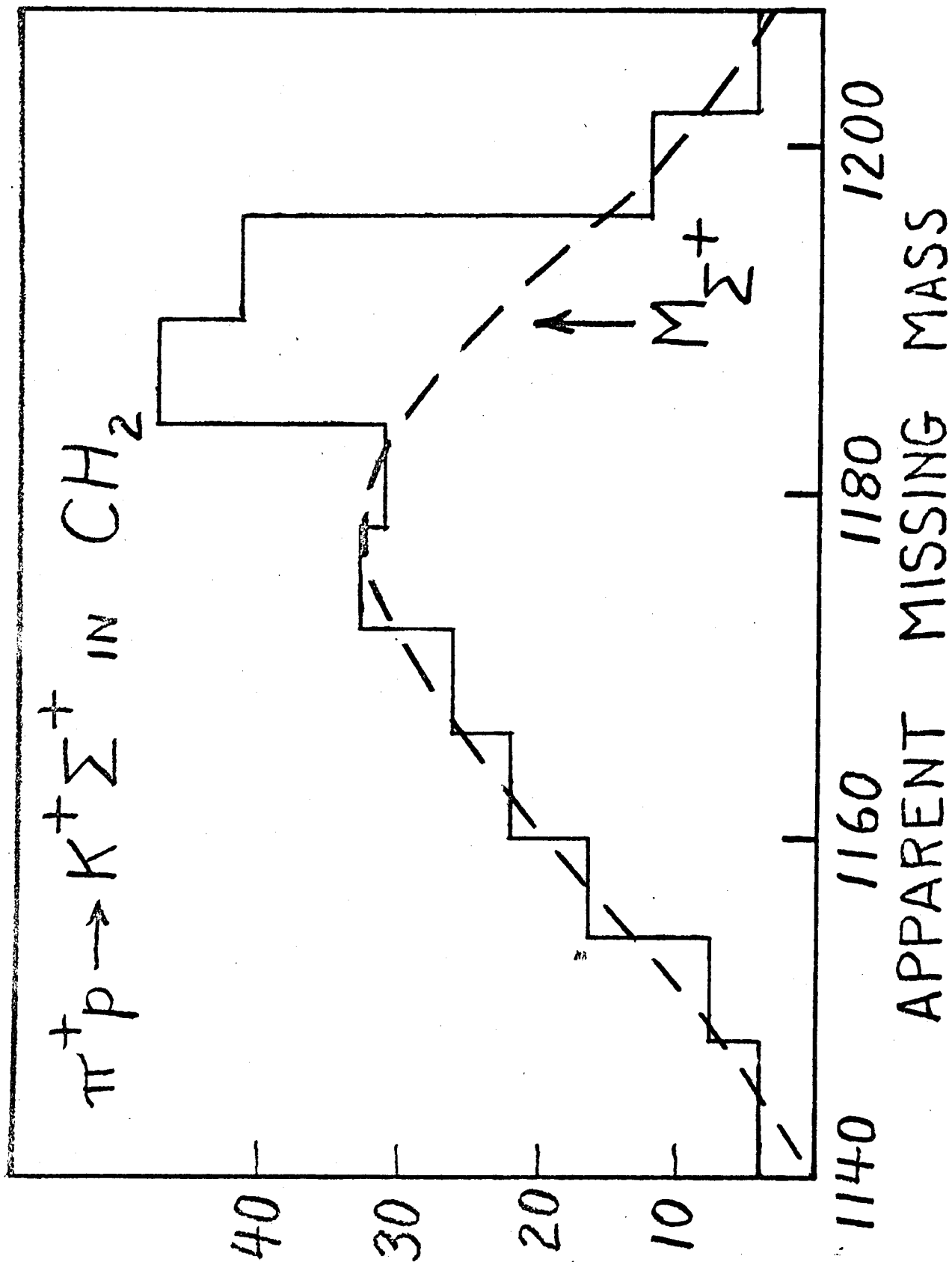

Fig. 6

This report was prepared as an account of Government sponsored work. Neither the United States, nor the Commission, nor any person acting on behalf of the Commission:

- A. Makes any warranty or representation, expressed or implied, with respect to the accuracy, completeness, or usefulness of the information contained in this report, or that the use of any information, apparatus, method, or process disclosed in this report may not infringe privately owned rights; or
- B. Assumes any liabilities with respect to the use of, or for damages resulting from the use of any information, apparatus, method, or process disclosed in this report.

As used in the above, "person acting on behalf of the Commission" includes any employee or contractor of the Commission, or employee of such contractor, to the extent that such employee or contractor of the Commission, or employee of such contractor prepares, disseminates, or provides access to, any information pursuant to his employment or contract with the Commission, or his employment with such contractor.