



Lawrence Berkeley Laboratory

UNIVERSITY OF CALIFORNIA

Accelerator & Fusion Research Division

Presented at the IEEE Particle Accelerator Conference,
San Francisco, CA, May 6-9, 1991, and to be
published in the Proceedings

Low Power RF System for the ALS Linac

C.C. Lo, B. Taylor, and H. Lancaster

May 1991

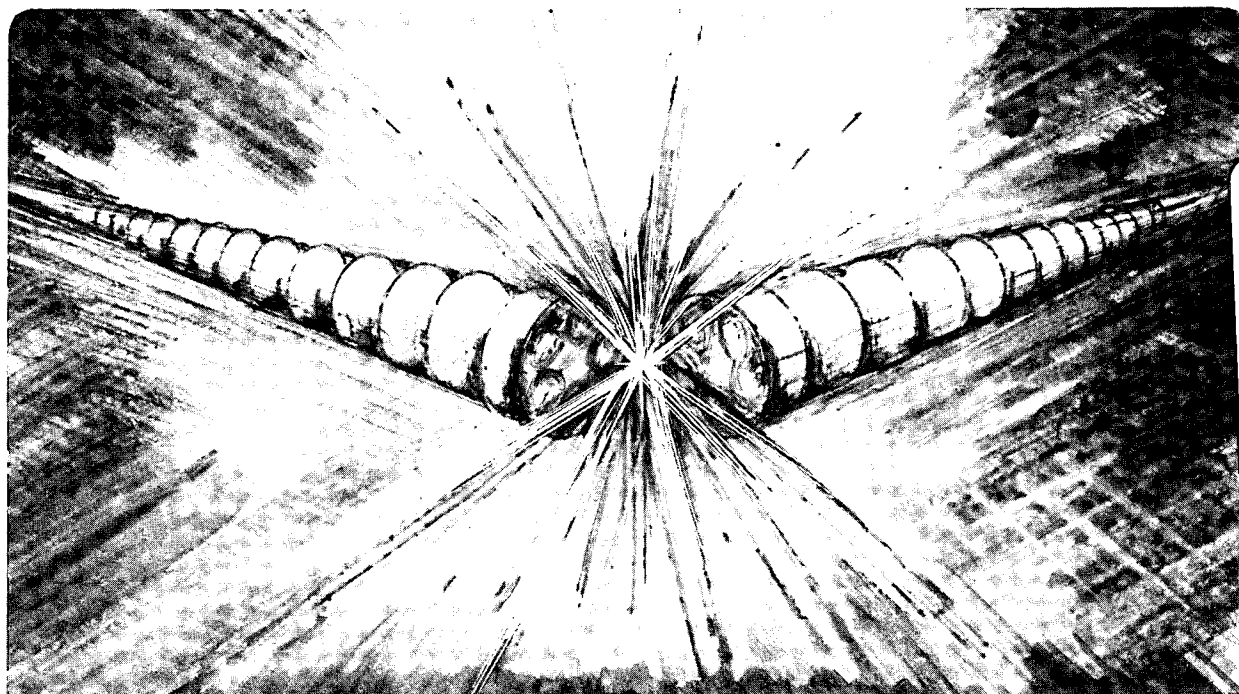

1 LOAN COPY 1
1 Circulates 1
1 for 4 weeks 1

Bldg. 50 Library.
Copy 2

LBL-29909

DISCLAIMER

This document was prepared as an account of work sponsored by the United States Government. While this document is believed to contain correct information, neither the United States Government nor any agency thereof, nor the Regents of the University of California, nor any of their employees, makes any warranty, express or implied, or assumes any legal responsibility for the accuracy, completeness, or usefulness of any information, apparatus, product, or process disclosed, or represents that its use would not infringe privately owned rights. Reference herein to any specific commercial product, process, or service by its trade name, trademark, manufacturer, or otherwise, does not necessarily constitute or imply its endorsement, recommendation, or favoring by the United States Government or any agency thereof, or the Regents of the University of California. The views and opinions of authors expressed herein do not necessarily state or reflect those of the United States Government or any agency thereof or the Regents of the University of California.

LOW POWER RF SYSTEM FOR THE ALS LINAC*

C.C. Lo, B. Taylor, and H. Lancaster

Accelerator and Fusion Research Division
Lawrence Berkeley Laboratory
University of California
Berkeley, CA 94720

May 1991

Paper presented to the IEEE Particle Accelerator Conference, San Francisco, CA, May 6-9, 1991

*This work was supported by the Director, Office of Energy Research, Office of Basic Energy Sciences, Materials Sciences Division of the U.S. Department of Energy, under Contract No. DE-AC03-76SF00098

LOW POWER RF SYSTEM FOR THE ALS LINAC

C.C. Lo, B. Taylor, and H. Lancaster

Accelerator and Fusion Research Division, Lawrence Berkeley Laboratory
University of California, Berkeley, CA 94720

Abstract

The Linear Accelerator (Linac) in the Advanced Light Source (ALS) is designed to provide either single or multiple bunches of 50 MeV electrons for the booster synchrotron. Three cavities are used in the Linac for electron bunching. The two subharmonic bunching cavities operate at 124.914 MHz and 499.654 MHz respectively. The S Band buncher operates at 2.997924 GHz. The low level RF system includes a master signal source, RF burst generators, signal phase control, timing trigger generators and a water temperature control system. The design and performance of the system will be described.

I. INTRODUCTION

The Linear Accelerator of the ALS is used to provide single or multiple bunches of 50 MeV electrons for the booster synchrotron. Figure 1 shows the major components of the ALS Linac. The electron gun serves as the source of the electrons. A series of up to 19 micro electron bunches or a single macroelectron bunch is initiated by pulsing the cathode or gating the grid of the electron gun, respectively. The cathode of the gun is being pulsed by 124.914 MHz pulses which are derived from the 499.654 MHz Master Oscillator. The electron bunches exiting the gun

and entering the 124.914 MHz buncher[1] has a width of 2.5 ns. The first buncher compresses the 2.5 ns bunch to a width of 800 ps. The 499.654 MHz buncher[1] further compresses the electron bunch to a width of 200 ps. After the 7th gap of the S Band buncher[2] the electron bunch attains a width of 20 ps. Input/Output ports have been provided for in all subsystems for the ALS Intelligent Local Controller (ILC) in the ALS Control System[3] to take control of most of the functions when required. Local controls on all functions are provided.

II. SYSTEM DESIGN AND OPERATION

The 499.654 MHz master oscillator[4] is composed of two individual oscillators. One is a temperature compensated crystal oscillator (TCXO) and the other is a oven controlled/voltage controlled crystal oscillator (OC/VCXO). The OC/VCXO provides a signal tunable through a range of +/- 100 KHz via the local control or through the ILC to facilitate various physics investigators. Nine signal distribution amplifiers each producing 1 W are used to distribute the master oscillator signal to wherever it is needed.

A 6X multiplier converts the master oscillator signal to 2997.924 MHz for the S-Band RF system whereas a divider converts the master signal to 124.914 MHz for the first

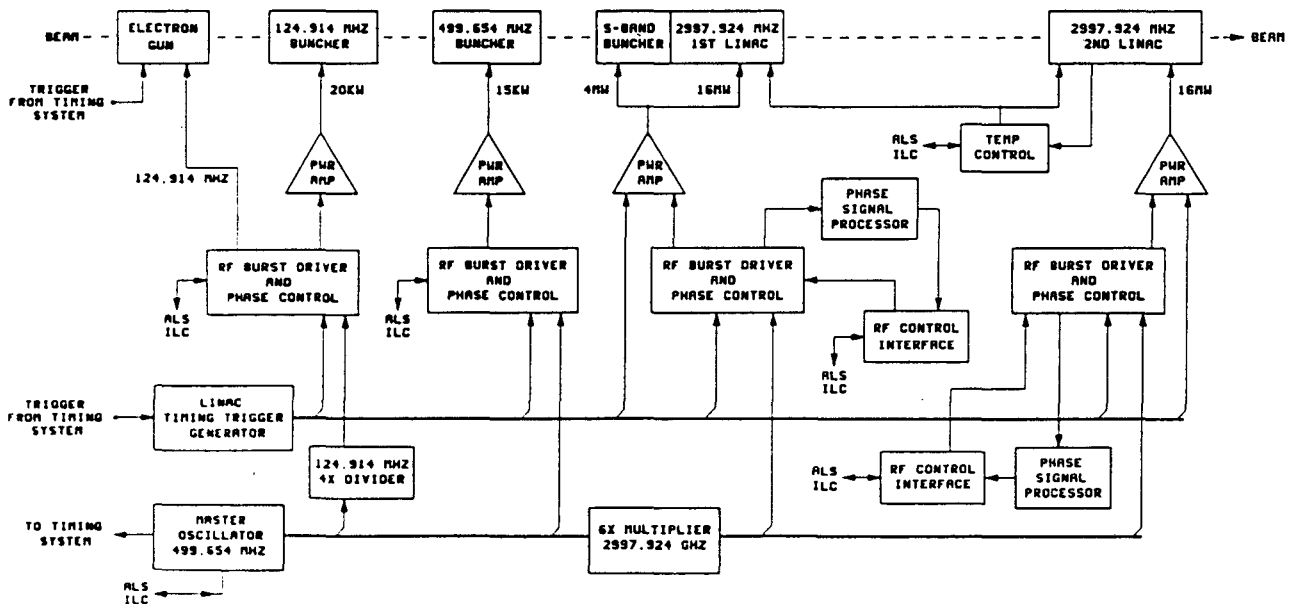

Figure 1. Block Diagram of the ALS Linac RF System

subharmonic buncher RF system as well as for the Gun pulsing and the ALS Timing System.

The Linac RF system operates in the pulse mode. The pulsing frequency is 10 pulses per second. Only one of these pulses interacts with electron bunches, the other 9 pulses are used for calibration and tuning purposes. Three RF burst generators are used to drive two subharmonic bunchers, the S-Band buncher and two Linac guides. Phase adjustments and phase loops have been implemented in the designs to insure proper bunching and compensating for detuning due to various factors. The two subharmonic bunchers are pulsed on for 20 μ S whereas the S-Band buncher and the two Linac guides are pulsed on for 1.5 μ S.

The Linac operates at a temperature of 40 degree C. The water temperature is precisely controlled to within 1 degree by a Water Temperature Controller which compares the sensor signal with a stabilized voltage reference. The bipolar error signal is processed by two polarized amplifiers; one for heating and one for cooling. The error signal is also available to the ILC. The ALS Linac only requires heating, therefore the cooling part of the device is not used. The heating control output range is 0 to +10 V which is the input requirement of the SCR heater supply. The temperature can be set either locally or via the ILC.

In the two subharmonic buncher systems, the outputs from the RF burst generators drive the high power amplifiers which follow, producing 20 KW and 15 KW for the 124.914 MHz and the 499.654 MHz systems respectively. Due to the low Q design of the buncher cavities, a phase control loop is probably not necessary and has not been implemented at this time.

In the S-Band system, the output of the 6X multiplier drives the SLAC solid state amplifier[5]. The RF gate is set at 8 μ S. The first 5-6 μ S allows the phase of the output signal to stabilize before the Klystron amplifier is pulsed on. A fast response phase shifter is built into the SLAC solid state amplifier to perform internal phase stabilization[5]. The same phase shifter is also used for beam loading compensation[6] in the ALS.

It is important to keep the phase relationship between the RF signal and the electron bunch(es) at a proper constant for maximum bunching effect. Besides the manual or ILC adjustable phase shifters, provision for a phase servo loop has been set up to minimize the phase change from pulse to pulse. Figure 2 shows the functional block diagram of the Signal Processor. The phase error signal is derived from the SLAC Phase and Amplitude Detector[7]. At the moment when all signal phases have stabilized within the 1.5 μ S S-Band RF burst, a sample of the phase error is taken, digitized and converted to a dc error voltage of the opposite sign. The voltage is fed back to the loop phase shifter and correct the phase for the next RF pulse. Since the transfer function of the phase and control voltage is not perfectly linear, the effectiveness of this concept still needs to be evaluated. The sampling of the phase error signal is only taken when there is no electron bunch to interact with the RF pulse. Output of the phase error signal and input for the phase correction to and from the ILC have been provided for possible future computer control of the phase loop.

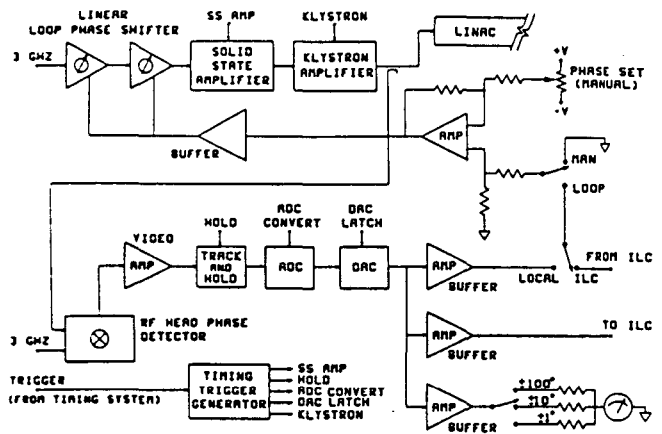

Figure 2. Block Diagram of the Phase Servo Signal Processor

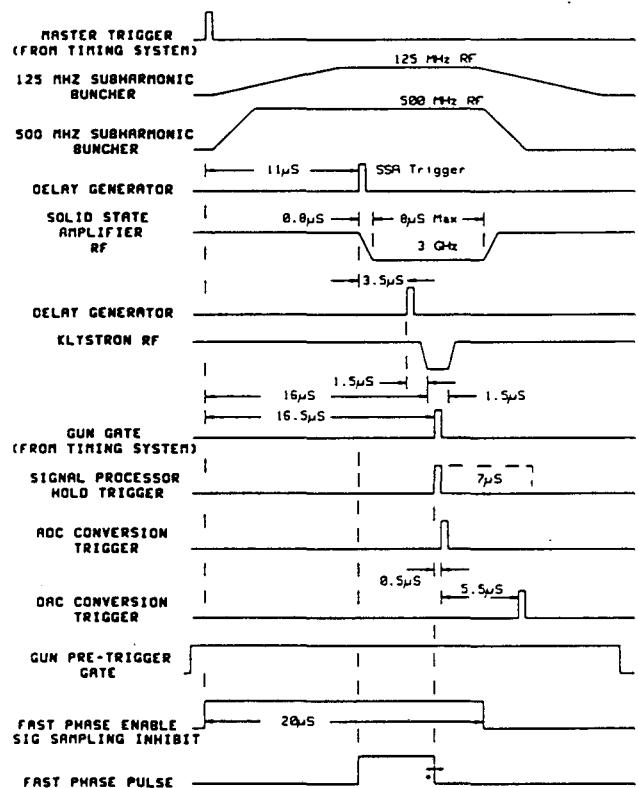

Figure 3. Timing Diagram of the ALS Low Power RF System

III. TIMING OPERATION OF THE SYSTEM

Figure 3 shows the timing operation of the Linac RF system. The sequence starts with a master trigger pulse, which either comes from the synchronized trigger generator in the Linac test phase or from the ALS Timing System in final operation. The master trigger pulse is then distributed via the Master Trigger Fan Out Module. The output trigger pulses are used to trigger the 125 MHz and 500 MHz buncher driver with each RF gate lasting 20 μ S. Another trigger pulse is used to initiate the 11 μ S delay

trigger for the S-Band solid state amplifier, which is gated on for 8 μ S. The Solid State Amplifier has an inherent delay and takes a total of 0.8 μ S for the RF to reach flat top. It takes another 4.7 μ S for the signal phase to stabilize; a total of 5.5 μ S to reach the phase stabilized region.

The solid state amplifier trigger starts two other delay triggers; one is the Klystron trigger which has a delay of 3.5 μ S and the other one is the signal processing hold trigger, which has a 5.5 μ S delay. From the time the Klystron amplifier is triggered to mid way of the flat top portion of the Klystron RF pulse, it takes 2 μ S. Therefore at the flat top portion of the Klystron RF gate, the Solid State Amplifier is also in the phase stabilized region. At this time, 16.5 μ S after the Master trigger, the Gun pulse arrives at the Linac. Also at this time when there is no Gun pulse, that is 9 out of 10 pulses, the signal processing hold trigger is initiated to sample the phase error of the system. 500 nS after the signal processing hold trigger, the ADC start convert trigger is started and 5.5 μ S after that, the DAC convert trigger is initiated. The output of the Signal Processing Module is a dc signal whose level corresponds to the phase error of the S-Band system. A dc signal with the opposite sign is sent to the loop phase shifter correcting the phase for the next RF pulse. The accuracy of the correction depends on the linearity of the transfer function of the phase and control voltage of the phase shifter.

A Gun pre-trigger signal from the Timing System is present whenever a gun pulse is expected. This pre-trigger pulse is used to start a 20 μ S gate which inhibits the sampling of the phase error whenever beam loading is expected. This 20 μ S gate also enables a Fast Phase Pulse which is necessary to compensate for the beam loading effect on the accelerator RF. The timing, the width, and the amplitude of the Fast Phase Pulse are adjusted to obtain the best results in beam loading compensation. This signal is sent to the fast phase shifter in the front end of the solid State Amplifier to change the phase of the RF signal to perform this task.

IV. CONCLUSIONS

The design and operation of the low power RF system for ALS Linac have been presented. A total of more than 30 pieces of electronics components have been fabricated to build the system. In the S-Band system, the phase shifters, the phase and amplitude detector and the solid state amplifier are built by SLAC. The Linac produced the first beam in February 1991 in the trial run. A 50 MeV beam was obtained as monitored by a Faraday Cup at end of the Linac in March 1991. The low power RF system electronics components, however, have been running since November of 1990 without any problem. Operating experience still have to be acquired to evaluate the effectiveness of the phase loop servo in the S-Band system.

V. ACKNOWLEDGMENT

The authors express their thanks to A. Geyer for his efforts in coordinating the fabrication of most of the electronics components in the system described.

*This work was supported by the Director, Office of Energy Research, Office of Basic Energy Sciences, Materials Sciences Division of the U.S. Department of Energy, under Contract No. DE-AC03-76SF00098

VI. REFERENCE

1. C.C. Lo, B. Taylor, H. Lancaster, and J. Guigli, "Advanced Light Source Linac Subharmonic Buncher Cavities;" Proceedings of 1989 IEEE PAC, Vol.1, pp. 956-958. LBL-25975.
2. B. Taylor, H. Lancaster, and H. Hoag, "Engineering Design of the Injector Linac for the Advanced Light Source;" Presented at the 1988 Linear Accelerator Conference, Williamsburg, VA, October 2-7, 1988, LBL-26025.
3. S. Magyary, et al., "Advanced Light Source Control System;" Proceedings of 1989 IEEE PAC, Vol. 1, pp. 74-78, LBL-28412.
4. C.C. Lo, B. Taylor and K. Baptiste, "Advanced Light Source Master Oscillator;" Proceedings of 1989 IEEE PAC, Vol. 1, pp. 118-120, LBL-25974.
4. J.G. Judkins, J.E. Clendenin and H.D. Schwarz, A Solid State High Power Amplifier For Driving The SLC Injector Klystron, Proceedings of 1985 IEEE PAC. SLAC-PUB-3610, March 1985.
5. J.G. Judkins, J.E. Clendenin, and H.D. Schwarz, "A Solid State High Power Amplifier for Driving the SLC Injector Klystron;" Proceedings of 1985 IEEE PAC, SLAC-PUB-3610, (March 1985).
6. F. Selph, "Compensation of Beam Loading in the ALS Injector Linac;" Presented at the 1988 Linear Accelerator Conference, Williamsburg, VA, October 2-7, 1988, LBL-25630.
7. J.D. Fox and H.D. Schwarz, "Phase and Amplitude Detector System for the Stanford Linear Accelerator;" Proceedings of 1983 IEEE PAC, SLAC-PUB-3071, March 1983.

LAWRENCE BERKELEY LABORATORY
UNIVERSITY OF CALIFORNIA
INFORMATION RESOURCES DEPARTMENT
BERKELEY, CALIFORNIA 94720