

UC Agriculture & Natural Resources

Proceedings of the Vertebrate Pest Conference

Title

Pocket gopher problems and control practices on national forest lands in the Pacific Northwest region

Permalink

<https://escholarship.org/uc/item/1kb99468>

Journal

Proceedings of the Vertebrate Pest Conference, 4(4)

ISSN

0507-6773

Author

Canutt, Paul W.

Publication Date

1970

POCKET GOPHER PROBLEMS AND CONTROL PRACTICES ON NATIONAL FOREST LANDS IN THE PACIFIC NORTHWEST REGION

PAUL R. CANUTT, Wildlife Biologist, Animal Damage Control Supervision, United States Forest Service, Portland, Oregon

Pocket gophers of concern to foresters in the Pacific Northwest belong to the genus Thomomys (13). The two species believed responsible for most conifer damage are the northern pocket gopher (T. talpoides) which occurs east of the Cascade mountains in Washington, Oregon, and south into the northeastern edge of California and the nearly identical Mazama pocket gopher (T. mazama), which ranges throughout western Oregon and into north central California (13).

Pocket gopher damage is best known to agriculturalists who for many years have suffered losses to root, hay, fruit, and bulb crops, as well as damage to irrigation canals (23). As early as 1922, Dixon (9) estimated gopher caused damage in California at eight million dollars annually. More recently, Marsh and Cummings (17) verified pocket gopher damage as a serious problem in California and other states.

Literature referring to gophers and their control on agricultural and range lands is common because these are recognized problem areas. On the other hand, gopher damage to forest crops has little published documentation. Crouch (7), in 1942, listed mortality of forest trees from root gnawing in his summary of destructive activities of pocket gophers. Absence of yellow pine (Pinus ponderosa) seedlings in forest openings in the Ochoco National Forest, Oregon, was related indirectly to pocket gophers by Moore (19) in 1943. He reported a positive correlation between white footed mouse (Peromyscus spp.) occupancy of unused gopher runways and absence of seedlings. Papers on gopher damage in pine plantations by Dingle (8) in 1956 and by Hermann (1) in 1963 complete the pertinent early literature.

Mounting concern with gopher damage by forest managers during the past five years has prompted additional investigation into the extent of the problem. A cooperative survey of animal-reforestation problems by the Pacific Northwest Forest and Range Experiment Station and the Pacific Northwest Region of the Forest Service placed pocket gophers high on the list of problem animals on National Forest lands in Oregon and Washington. Gophers ranked equally with porcupines as second to deer in importance (5).

Black, et al., (2) in another survey, found that gophers caused high plantation mortality or greatly suppressed conifer growth and rated them an important problem animal in Washington and Oregon.

Most forest gopher problems in the Pacific Northwest occur in areas disturbed by clear-cut logging or wildfire. Again literature is lacking on attendant ecological responses. However, it is a reasonable assumption that gophers thrive following site disturbances which increase food. It is well known that both variety and abundance of forbs, brush, and grasses usually increase following removal of overstory trees or brush.

Pocket gopher damage to trees is undoubtedly not new but was relatively unnoticed until intensified reforestation efforts within the past 15 to 20 years plus increased plantation surveillance brought about a disturbing awareness of the problem.

Current reforestation practices rely more heavily on planting two and three year old nursery grown trees than on natural or artificial seeding, especially in the yellow pine region where gopher problems are most severe. Enough trees are planted to withstand moderate losses from a variety of causes; however, when expected mortality increases markedly from pocket gophers, unsatisfactorily stocked plantations often result.

An example of gopher-caused plantation failure occurred recently on the Winema National Forest in Oregon. Restocking on the 1,600 acre Chiloquin Burn was virtually destroyed by pocket gophers within six years after planting in 1961. In addition to losing the estimated \$200,000 planting cost, the Forest forecasts an annual growth loss of 450,000 board feet until the area can be restocked. The Chiloquin burn represents the largest single gopher problem area in the Pacific Northwest Region, but it is not unique.

To this point only Ponderosa pine injuries have been discussed. However, I have also observed gopher damage on lodgepole pine (Pinus contorta), Jeffrey pine (Pinus jeffreyi), western larch (Larix occidentalis), and Douglas-fir (Pseudotsuga menziesii). Stein (13) and

Teviss (14) have reported gopher feeding on red firs (*Abies* spp.). Very likely, most conifer species are injured if in the right place at the right time.

Pocket gophers injure conifers by pruning roots, barking stems, partially removing stems and crowns, or totally removing small or newly planted seedlings. Gophers feed most actively on trees during the winter but may cause damage at any season.

Above ground gopher damage can be identified from tooth marks approximately 1/16 inch wide in the bark or wood of trees, and soil mounds, runways, or soil casts near damaged trees. Gophers will often chew deeply into the wood of old seedlings and young saplings, producing a sculptured effect. In contrast, porcupine barking which has been confused with gopher feeding usually does not penetrate much beyond the sapwood. Also, porcupines frequently bite off and discard small fragments of ponderosa pine outer bark and these fragments may be found around the base of the seedling or sapling.

Root pruning is often not discovered until distress signs begin to appear. Larger trees may retain green crowns, but because of improper anchorage will be tilted at odd angles. Severe root pruning will cause extreme stress or death with a crown color change to yellow red. Pulling on these trees will reveal lack of roots. Trees 8 or 10 feet in height often can easily be pulled out of the ground when root damage is severe. It may sometimes be necessary to dig soil away from the roots to confirm the cause of damage.

CONTROL TECHNIQUES

Because of the great impact of pocket gophers on agricultural production, most control methods have been developed to protect crops, pastures and ranges.

Techniques for poisoning with strychnine treated corn, fruits, and vegetables, trapping, and fumigating with carbon bisulfide were described by Lantz in 1908 (16). Other direct controls include flood irrigation (9), soil compaction with a sheeps-foot packer (29), entrapment using a combination of ditches and buried cans for pitfalls (9), and shooting with a shotgun (6). Young fruit trees have been protected by burying wire cages around the roots (9). Fostering gopher predators such as owls and snakes has also been suggested (9).

Habitat manipulation to control gophers has received some attention in recent years. Crop rotation from root crops or alfalfa to grains provides a break in the food chain and helps prevent large population buildups (4). In Colorado, spraying rangelands with 2,4-D to control broad-leaved forbs significantly reduced pocket gopher carrying capacity (14) (26). The reduced capacity was attributed directly to reduction of forbs as they were found to be the most important segment of the gophers diet.

Most known control methods are effective in limited situations, but the only technique proven useful over a wide range of conditions, is baiting with toxic compounds. It is interesting that hand baiting was also one of the first controls developed. Baiting is unquestionably the only current practice which provides a means of coping with extensive forestland-gopher problems. The two basic techniques presently used to protect conifers are baiting by hand or machine.

Hand Baiting

Two types of bait are currently recommended by the Bureau of Sport Fisheries and Wildlife for use on National Forest lands in the Pacific Northwest. These are 1/2x2-1/2-inch carrot strips dusted with strychnine alkaloid powder at the rate of 1 ounce of strychnine to 16 pounds of carrots (27), and steam crushed oats treated with 1 ounce of strychnine to 10 pounds of oats (21). A rhoplex adhesive is used to bind strychnine to the oats.

The hand baiting technique is essentially that described by Crouch (6) in 1933 and in many subsequent publications available from most state university extension offices. Briefly, it consists of locating and opening the main runway of each gopher with a probe or trowel, placing bait in two areas of the run, and carefully closing bait entry holes to keep out light following application.

Baiting is usually done in late summer and fall since gopher mound building increases noticeably during this period. When working with poorly structured soils it is sometimes necessary to wait until the first fall rains. The moisture increases soil adhesiveness and permits more effective runway probing or digging.

Hand baiting costs depend on several variables including gopher density, terrain, amount of ground vegetation and debris, quality of baiters, and travel distance to the job. Umatilla National Forest personnel have baited moderately dense gopher populations in clear-cut logging areas for less than \$6.00 per acre (12). This is roughly comparable to treating 5 acres per day of heavily infested agricultural lands reported by Dixon (9), and considerably better than the 1/2 to 1 acre per day required by Dingle (8) to treat research plots in a conifer plantation. I have baited moderately dense gopher infestations at the rate of 1 acre per hour using a combination probe-bait dispenser developed by Hanson (10).

Data on hand baiting effectiveness are lacking for forest areas. Moore and Reid (20) suggest that thorough treatment by an efficient crew should provide 90% control, and Miller and Howard (18) reported an effective field kill averaging about 80% on agricultural lands.

Mechanical Baiting

The most important improvement in gopher control in recent years has been the introduction of a machine which constructs a burrow and deposits grain bait in one operation. Original development of mechanical baiting took place concurrently in Colorado under the guidance of the Colorado Cooperative Gopher Control Project (28), and in California at the University of California Field Station at Davis (15).

The machines were both developed primarily for use on agricultural lands and were not durable enough to operate day after day in forest soils with their greater amounts of rock and heavy roots. Limited trials with the heavier Colorado machine resulted in almost continuous shear bolt breakage. Nevertheless, the potential for using the machine in conifer plantations appeared sufficiently promising by 1965 for the Pacific Northwest Region of the Forest Service to begin development of a forest-land burrow builder based on the Colorado machine. Basic design work on the burrow builder was completed with the help of the U.S. Forest Service Equipment Testing and Developing Center at Missoula, Montana (figure 1). Detailed plans for the machine and instructions for operation and use are presently available from the U.S. Forest Service Regional Office in Portland, Oregon. Several recent modifications are currently being detailed and will soon be available.

Burrow Builder Operation

The baiting operation is relatively simple. A torpedo-like device is moved through the soil, parallel with the surface, wedging and shaping a round burrow approximately two inches in diameter. The top of the burrow is closed by packing wheels located immediately above the rear of the torpedo. The packing wheels also control burrow depth and drive the bait feeder.

Bait is the same strychnine-oat formulation used for hand baiting. About 2 pounds of bait per acre are placed in parallel artificial burrows approximately 20 feet apart.

For best results, the burrow builder should be pulled by a crawler tractor developing 30 drawbar horsepower fitted with a vertical-lift king-pin hitch. An adapter for the burrow builder also allows it to be mounted to either category 1 or 11 three-point hitches, but this arrangement does not give the flexibility in turning of the king-pin articulation.

Burrows can be built through a wide range of soil texture classes, with sands and silts performing best. Soils containing mostly gravel often have insufficient fine materials to bind particles together. Heavy clays do not permit proper entry of the burrow builder as presently designed, but gopher-reforestation problems do not usually occur in these soils.

Soil moisture must be adequate for proper burrow formation. A rule of thumb to use, is that soil moisture is sufficient if the soil forms a cast when a handful is squeezed.

The burrow builder will perform satisfactorily through moderate amounts of subsurface roots and rocks and, although desirable, it is not necessary to have continuously formed and well-baited burrows to obtain good control. Concentrations of large surface obstructions like large limbs, logs, or dense brush seriously interfere with burrow construction. Lanes should be cleared to allow access if it is necessary to control gophers in such areas. This type of site preparation can often be coordinated with slash disposal plans if a gopher problem is anticipated. Brushfield site preparation in gopher problem areas should provide clearings wide enough to permit a tractor to move through lanes without destroying planted trees.

Baiting Costs

Treatment costs vary greatly from area to area and are mainly dependent on amounts of surface and subsurface obstructions. Costs were kept for two projects on the Chemult Ranger District of the Winema National Forest (22). One site was exceptionally easy to treat and the other difficult. Treatment costs per acre on these jobs were \$2.65 and \$7.35, respectively. These expenditures were developed for actual time to treat given acreages and do not include move-in time, transportation, experimental testing time or breakdown. The reason for excluding the foregoing items was to establish a base rate. Supplemental expenses are recognized as project items but are not proportional from one job to another. For example, a pro rata share on a 500 acre project would be much less than on a 15 acre project.

Present data indicate that acres per hour rates for easily treated sites are 6; for moderately easy sites 5; and for difficult sites 2.5.

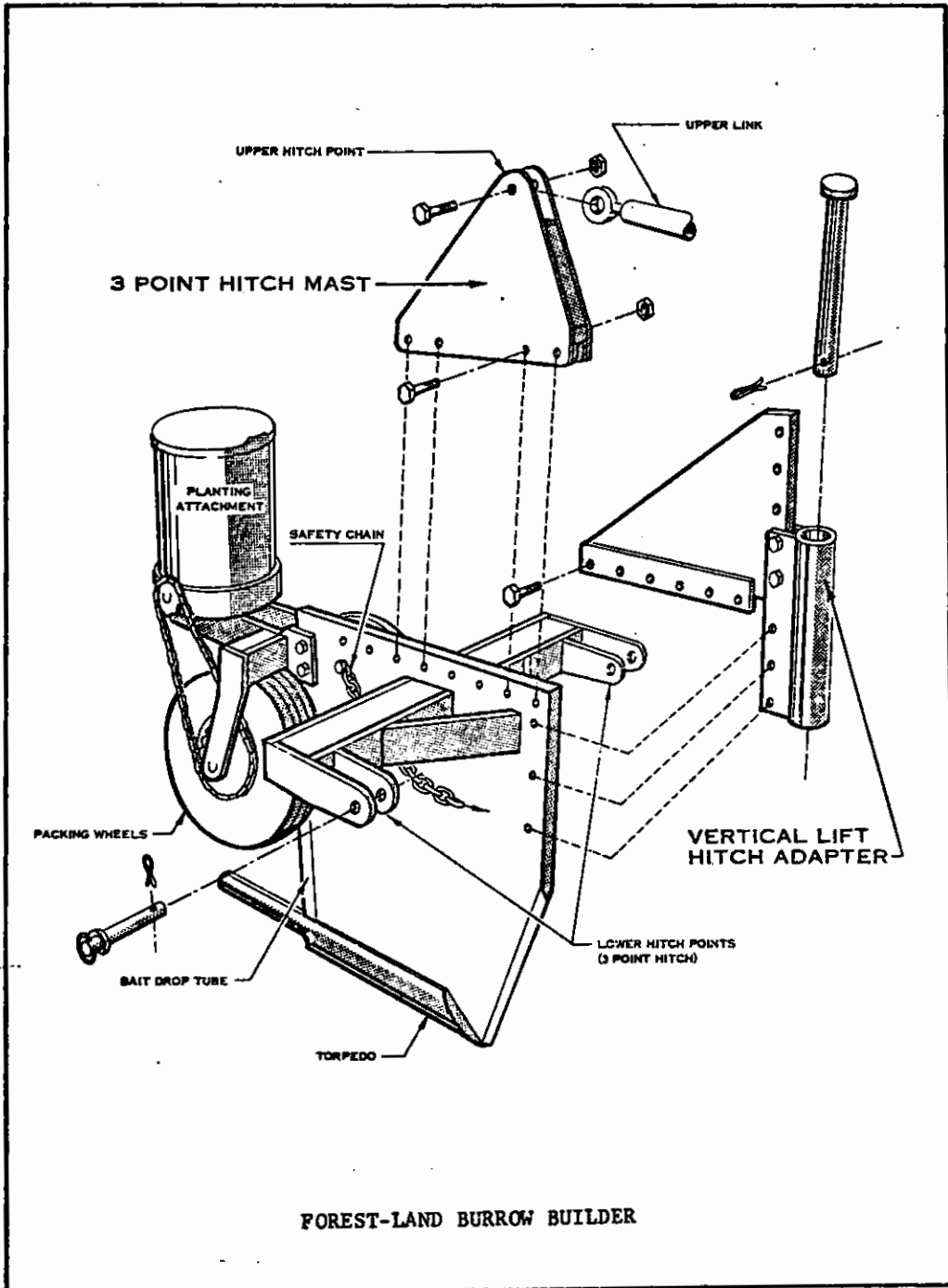

FOREST-LAND BURROW BUILDER

U. S. FOREST SERVICE EQUIPMENT DEVELOPMENT CENTER
MIDWINTER, MONTANA

FIGURE 1.

Baiting Effectiveness

The Bureau of Sport Fisheries and Wildlife, Olympia Field Station has been evaluating control effectiveness for two years and has produced initial control in excess of 90 percent. However, in 1969, gophers reoccupied baited areas 2 to 4 months following treatment (1).

Quick gopher recovery following spring baiting may have occurred because of invasion from untreated perimeters or reproduction of missed animals in the baited areas or a combination of the two.

Gopher population recovery creates a serious potential for tree loss during the critical winter period, so the writer conducted additional burrow builder tests to determine effectiveness of fall control.

The initial study was established on the Winema National Forest with help from Forest personnel. In October 1969, 17.4 acres were treated and an area of equal size and gopher activity was selected for the control. Fifty 1/50 acre circular plots were established on the control and 50 on the treatment area. Forth-eight hour mound counts* described by Keith, et al. (14), were used to measure relative activity between plots.

Results indicated 100% control. Sixty-four percent of the control plots had new mounds and the treatment plots had none. Measurements will be continued for one year to measure reinvasion pattern.

The second study was conducted on the Deschutes National Forest to complement Spring 1969 baiting studies of the Olympia Field Station. Snowfall prevented determination of initial control effectiveness, but 200 pine seedlings were staked to measure overwinter damage. Injuries on these trees will be compared to the control plot trees established by the Olympia Field Station and will be a basis for comparing effectiveness of fall and spring baiting in protecting conifers.

CONCLUSIONS

Lack of basic information on pocket gopher ecology and damage control is preventing prompt reforestation on large acreages. Although some research has been undertaken recently, it is only preliminary. More intensive efforts over a broad range of gopher-forest site relationships will be needed if problems are to be solved.

Some apparent areas of forest-gopher ecology needing study are: population dynamics, movement patterns, seasonal activity, food habits, habitat preferences, and effects of forest management programs on populations.

As basic facts become available, it will be possible to integrate habitat modification, silvicultural practices, and direct control to provide necessary conifer protection. If research productivity lags, we will continue on a hit and miss basis and much needed timber production will be lost.

*Counts are made by eradicating existing gopher mounds, plugs or casts, and returning 48 hours later to determine number of plots with new sign.

LITERATURE CITED

1. BARNES, VICTOR G., Unpublished research findings U.S. Bureau of SF & W Research Files. Olympia, Washington.
2. BLACK, HUGH C., EDWARD J. DIMOCK II, WENDELL E. DODGE and WILLIAM H. LAWRENCE. 1969. Survey of Animal Damage on Forest Plantations in Oregon and Washington. Trans. Thirty-fourth N. American Wildlife and Nat. Res. Conf. Pub. by Wildlife Mgt. Inst. pp. 388-408.
3. BUECHNER, HELMUT K. 1942. Interrelationships between the pocket gopher and land use. Jour. Mammal. 23: 346-348.
4. Colorado Cooperative Pocket Gopher Proj. 1960. Pocket Gophers in Colorado. Col. St. U. Exp. Sta. Bull. 508-S. Fort Collins, Colorado, 26 pp.
5. CROUCH, GLENN L. 1969. Animal damage to conifers on National Forests in the Pacific Northwest Region. U.S.D.A. Forest Serv. Resource Bull. PNW-28, 13 pp., illus. Pacific Northwest Forest and Range Experiment Station, Portland, Oregon.
6. CROUCH, W. E. 1933. Pocket Gopher Control U.S.D.A. Farmers Bull. No. 1709 Washington, D.C. 21 pp.

7. CROUCH, W. E. 1942. Pocket Gopher Control U.S.D.I. Conservation Bull. 23 Washington, D.C. 20 pp.
8. DINGLE, RICHARD WM. 1956. Pocket Gophers as a cause of Mortality in Eastern Washington Pine Plantations. Jour. For. Vol. 54. pp. 832-835.
9. DIXON, JOSEPH. 1922. Control of the Pocket Gopher in California. Bull. No. 340. University of California Press. Berkeley, Calif. 16 pp.
10. HANSEN, RICHARD M. 1956. New Dispenser Aids Gopher Control. Pamphlet 1-S. Agric. Exp. Sta. Colorado A. and M. College, Fort Collins, Colorado. 8 pp.
11. HERMANN, RICHARD K. and HAROLD A. THOMAS. 1963. Observations on the Occurrence of Pocket Gophers In Southern Oregon Pine Plantations. Journ. For. Vol. 61, No. 7. pp. 527-528.
12. HORNBECK, RAY. 1958. Hand Gopher Control. Proceedings First Reforestation Workshop. March 6-8, 1968. pp. 235-245. U.S. Forest Service, Region 6, Portland, Oregon.
13. INGLES, FLOYD G. 1965. Mammals of the Pacific States. Stanford University Press, Stanford, Calif. 506 pp.
14. KEITH, JAMES O., RICHARD M. HANSEN and A. LORIN WARD. 1959. Effect of 2,4-D on Abundance and Foods of Pocket Gophers. Journ. Wildl. Mgt. Vol. 23, No. 2, April 1959. pp. 137-145.
15. KEPNER, R. A., W. E. HOWARD, M. W. CUMMINGS, and E. M. BROCK. Undated. U. C. Mechanical Gopher Bait Applicator. U. of Cal. Agric. Ext. Serv. Pub. AXT-32, 12 pp.
16. LANTZ, DAVID E. 1908. Directions for Destroying Pocket Gophers. U.S.D.A. Bureau of Biological Survey. Circular No. 52 Revised Edition.
17. MARSH, REX E. and MAYNARD CUMMINGS. 1968. Pocket Gopher Control with Mechanical Bait Applicator. U. of Calif. Ag. Ext. Ser. AXT-261. 8 pp.
18. MILLER, MILTON A. and WALTER E. HOWARD. 1951. Size of Bait for Pocket Gopher Control. Journal of Wildlife Mgt. Vol. 15 No. 1. pp. 62-68.
19. MOORE, A. W. 1943. The Pocket Gopher In Relation to Pine Reproduction. Journal Mammal. Vol. 24. No. 2, pp. 271-272.
20. MOORE, A. W. and ELBERT H. REID. 1951. The Dalles Pocket Gopher and its Influence on Forage Production of Oregon Mountain Meadows. U.S.D.A. Circular No. 884. 36 pp.
21. NELSON, WILLARD E. 1969. Bureau of Sport Fisheries and Wildlife. Memo designating 1-10 strychnine treated oats for use in pocket gopher control. U.S. Forest Service files, Portland, Oregon.
22. PANELLI, MICHAEL. 1970. Office memorandum giving cost details of two gopher control projects. Chemult Ranger District, Chemult, Oregon. 2 pp.
23. SCHEFFER, THEO H. 1931. Habits and Economic Status of the Pocket Gophers. U.S.D.A. Tech. Bull. No. 224, Washington, D. C. 27 pp.
24. STEIN, W. I. 1954. Natural reproduction of Shasta red fir from a single good cone crop. U.S.F.S. PNW For. & R. Exp. Sta. Res. Note No. 100. 5 pp.
25. TEVIS, L. JR. 1956. Pocket gophers and seedlings of red fir. Ecology 37: 379-381.
26. TIETJEN, HOWARD P., CURTIS K. HALVORSON, PAUL L. HEGDAL and ANCEL M. JOHNSON. 1967. 2,4-D Herbicide, Vegetation and Pocket Gopher Relationships, Black Mesa, Colorado. Ecology Vol. 48, No. 4. pp. 534-643.
27. U.S.D.I. F & W Serv., BSF & W, Div. of Wildlife Services. 1966. Pocket Gophers and their Control in Oregon. Portland, Oregon. 2 pp.
28. WARD, LORIN A. and RICHARD M. HANSEN. 1960. The Burrow Builder and its use for Control of Pocket Gophers. U.S.D.I. Fish and Wildlife Service Special Scientific Report, No. 47. 7 pp.
29. WARD, LORIN A., PAUL L. HEGDAL and HOWARD P. TIETJEN. 1964. Annual Progress Report Colorado Cooperative Pocket Gopher Project. Forestry and Range Mgt. Section, Colorado State University, Fort Collins, Colorado. 20 pp.