

# Lawrence Berkeley National Laboratory

## LBL Publications

### Title

Mechanical Properties of Nb<sub>3</sub> Sn Stranded Superconducting Potted Cable Windings

### Permalink

<https://escholarship.org/uc/item/1m07p1zg>

### Authors

Caspi, S

Meuser, R B

Wolgast, R C

### Publication Date

1982-11-01

### Copyright Information

This work is made available under the terms of a Creative Commons Attribution License, available at <https://creativecommons.org/licenses/by/4.0/>



# Lawrence Berkeley Laboratory

UNIVERSITY OF CALIFORNIA

## Accelerator & Fusion Research Division

RECEIVED  
LAWRENCE  
BERKELEY LABORATORY

FEB 9 1983

LIBRARY AND  
DOCUMENTS SECTION

Presented at the 1982 Applied Superconductivity Conference, Knoxville, TN, November 28-December 3, 1982; and to be published in the Proceedings

MECHANICAL PROPERTIES OF Nb<sub>3</sub>Sn STRANDED SUPERCONDUCTING POTTED CABLE WINDINGS

S. Caspi, R.B. Meuser, and R.C. Wolgast

November 1982

**TWO-WEEK LOAN COPY**

*This is a Library Circulating Copy  
which may be borrowed for two weeks.  
For a personal retention copy, call  
Tech. Info. Division, Ext. 6782.*

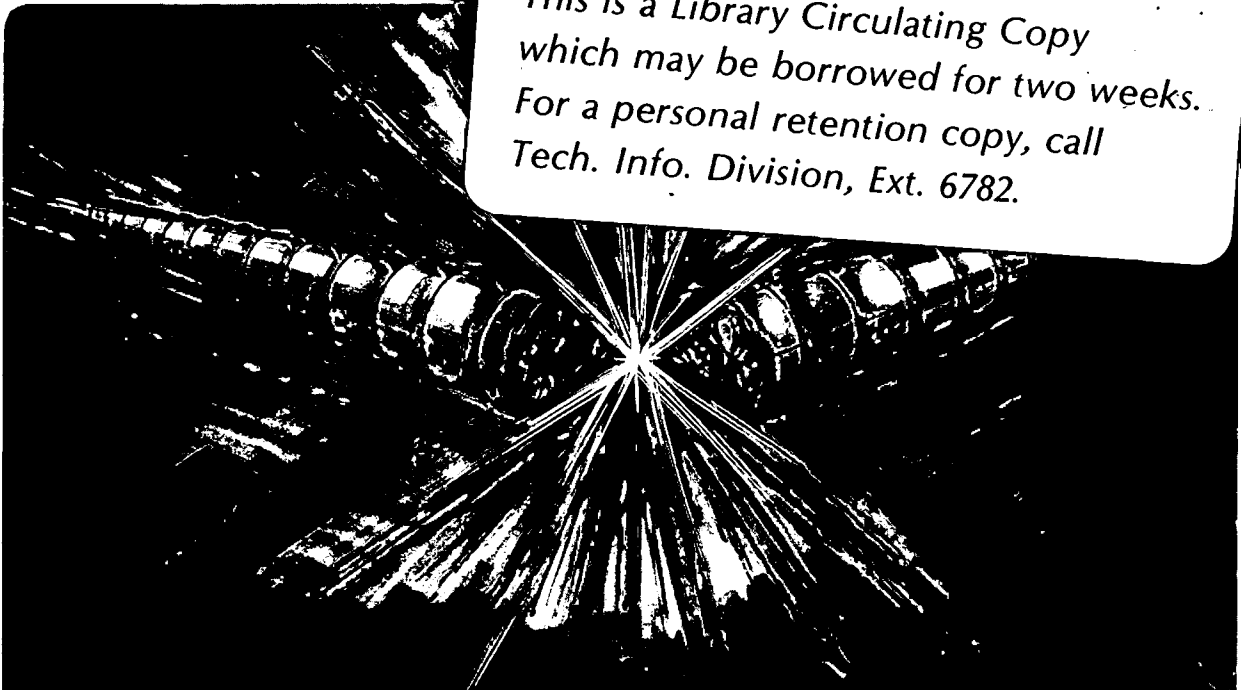

LBL-14481  
e.2

## **DISCLAIMER**

This document was prepared as an account of work sponsored by the United States Government. While this document is believed to contain correct information, neither the United States Government nor any agency thereof, nor the Regents of the University of California, nor any of their employees, makes any warranty, express or implied, or assumes any legal responsibility for the accuracy, completeness, or usefulness of any information, apparatus, product, or process disclosed, or represents that its use would not infringe privately owned rights. Reference herein to any specific commercial product, process, or service by its trade name, trademark, manufacturer, or otherwise, does not necessarily constitute or imply its endorsement, recommendation, or favoring by the United States Government or any agency thereof, or the Regents of the University of California. The views and opinions of authors expressed herein do not necessarily state or reflect those of the United States Government or any agency thereof or the Regents of the University of California.

MECHANICAL PROPERTIES OF Nb<sub>3</sub>Sn STRANDED SUPERCONDUCTING  
POTTED CABLE WINDINGS

S. Caspi, R. B. Meuser, R. C. Wolgast

November 1982

Accelerator and Fusion Research Division  
Lawrence Berkeley Laboratory  
University of California  
Berkeley, California 94720

\*This work was supported by the Director, Office of Energy Research, Office of High Energy and Nuclear Physics, High Energy Physics Division, U. S. Dept. of Energy, under Contract No. DE-AC03-76SF00098.

# MECHANICAL PROPERTIES OF Nb<sub>3</sub>Sn STRANDED SUPERCONDUCTING POTTED CABLE WINDINGS\*

S. Caspi, R. B. Meuser, R. C. Wolgast  
Lawrence Berkeley Laboratory  
University of California  
Berkeley, CA 94720

## Summary

The electromagnetic stresses in projected designs of high-field magnet coils sometimes exceed the yield points or creep strengths of the presently used coil winding materials. This is especially true of react-after-winding Nb<sub>3</sub>Sn coils, plastic insulating materials, and the crossed strands of twisted cable.

This report presents compression stress-strain curves of stranded and twisted flat cable coil winding specimens for reacted and epoxy-impregnated Nb<sub>3</sub>Sn coils, at 300 K and 80 K. The lateral and longitudinal strains of one specimen were measured along with the direct compressive stress-strain, at 300 K. A similar specimen was compressed to 40 MPa (6 kpsi) at room temperature and then to 145 MPa (20 kpsi) at 80 K. Plastic flow occurred up the maximum stress. Stress cycles subsequent to maximum stress were elastic. Some specimens were mounted in a rigid enclosure to simulate hydrostatic containment of the magnet coil. Pure annealed Cu was tested at 300 K, and pure epoxy was tested at 300 and 80 K. In addition the thermal contractions from 300 to 80 K were measured.

## Introduction

One kind of superconducting magnet currently under development at the Lawrence Berkeley Laboratory employs Nb<sub>3</sub>Sn flat cable, wrapped with fiberglass tape insulation, and vacuum impregnated with epoxy. For a 10 T central field in a block design, a compressive "minimum principal stress" of over 20,000 psi is expected to develop locally, and an average compressive stress of 12,000 psi along its midplane. This level of stress should be carried by the conductor without degrading it. Past behavior of superconducting magnets, especially dipoles, had shown a close relation between the magnet "training" curve and the cable mechanical properties, which are nonlinear, orthotropic, inelastic and temperature dependent. The cable is "poorly behaved" to such a degree that it is not yet possible to characterize it in a general way by a few of the usual mechanical parameters. We are therefore presenting the complete stress-strain curves for the test conditions most relevant to magnet design.

## Scope

Compressive stress-strain measurements were made for wind-and-react Nb<sub>3</sub>Sn epoxy impregnated coil specimens. One cable (Rutherford type) and one epoxy formulation were used to make the specimens (except for one epoxy bond test). Most of the measurements were made with the load applied normal to the broad face of the conductor. In one of these tests the strains in the lateral and longitudinal (along the length of the conductor) directions were measured as well as the strain in the load direction. One test was made with the load normal to the narrow face of the cable. Some tests were made with the coil specimen rigidly enclosed on all sides. Three coil

specimens were tested at 77 K. Two shear tests were performed to measure the bond strength of the copper-clad cable to the epoxy. Stress-strain measurements were made for pure annealed copper and for pure epoxy at 295 K and 77 K. The test conditions are summarized in the table below. As yet, the program has not included measurements of the effect of the anticipated strains upon the superconducting critical current.

TABLE I: List of Tests Performed

Specimen Type	Max. Test Stress (kpsi)	Temp. (K)	Remarks
Nb <sub>3</sub> Sn Coil Matrix	16	295	Load perpendicular to the broad face of the conductor, strain in load direction
"	"	"	Strain in lateral
"	"	"	Strain in longitudinal direction
"	15	77	After 295 K test to 15 kpsi
"	20	295	Rigidly enclosed sides
"	"	77	After 295 K test to 20 kpsi
"	"	"	Rigidly enclosed sides, new specimen
"	15	295	Load perpendicular to narrow face of conductor
Copper	15	295	OFHC Annealed
Epoxy	15	295	Vacuum degassed
"	20	77	" "

## Preparation of the Test Specimens

The Nb<sub>3</sub>Sn coil specimens were prepared by winding Rutherford cable conductor into flat "racetrack" coils, firing the coil to form the Nb<sub>3</sub>Sn, and then vacuum impregnating the coil with epoxy. The conductor was 23 strand Rutherford cable manufactured by the internal bronze process with a tantalum barrier, 1.27 mm x 7.8 mm overall cross-section. The stabilizing copper to non-copper volume ratio was 2:1, and the strand diameter was 0.76 mm. The strands were annealed many times during fabrication and the cable was delivered in a partially soft condition, quite soft and inert compared to typical Nb-Ti cable. The cable was compacted to a solid fraction of about 85%. The cable was wound in the as-manufactured surface condition. Turn-to-turn insulation was provided by spiral wrapping the cable with a high temperature fiberglass tape that had been wet with melted parafin wax for ease of handling. (Parafin will not be used

\*This work was supported by the Director, Office of Energy Research, Office of High Energy and Nuclear Physics, High Energy Physics Division, U. S. Dept. of Energy, under Contract No. DE-AC03-76SF00098.

in the next specimens.) The racetrack was wound with two conductor lengths started at the inner turn and insulated from the coil form and from each other. The glass tape was 1 cm wide and 0.13 mm (.005 in.) thick. The tape width was not uniform by as much as 1 mm. In order to avoid overlapping in making the "butt" wrap, gaps up to 1 mm were present. The cable was wound on an inner form 152 mm (6 in.) long x 25.4 mm (1 in.) wide with semicircular ends. Sixteen turns were wound to make a winding depth of about 24 mm. After winding and before epoxy impregnation the coil was compressed on the straight lengths of the outer turns to 2.9 MPa (422 psi), and tested for turn-to-turn voltage breakdown. The breakdown voltage was 680 VDC which is about 35% of that predicted by Paschen's Curves for the 0.25 mm distance between conductors. A second racetrack of the same type was compressed to 8.8 MPa (1270 psi) with the same result. The area of turns facing each other was 476 cm<sup>2</sup>. The coil was then mounted in a stainless steel fixture holding the same winding depth corresponding to the 2.9 MPa compression. The coil was baked out in a low vacuum oven at 200°C for 4 hours to remove most of the paraffin. The coil was baked in a high vacuum furnace at 700°C for 48 hours and then at 750°C for 48 hours to form the Nb<sub>3</sub>Sn. The coil was transferred to a vacuum potting form which held a light compression on the winding depth. The epoxy formulation used was 500 g of EPON 826, 500 g EPON 736, 280 g TONOX; cured for 8 hours at 60°C and 8 hrs at 80°C. After potting the turn-to-turn resistance was measured to be 12 ohms, assumed to be due to carbon from decomposition of the sizing, which would not be present in a production coil. The impregnation was complete, including the spaces inside the two strand layers of the cable, except for several groups of half mm sized bubbles on the sides of the winding. Specimens for mechanical testing were cut from the straight lengths of the racetrack. All the samples reported were approximately 25 mm in the compression direction x 8 mm wide x 25 mm long in the conductor length direction. Specimens which were loaded to 145 Mpa (20 kpsi) were only 19 mm long. The "edge-loaded" specimen was made by gluing with epoxy three pieces cut from the winding.

The copper specimen was cut from OFHC bar and was annealed in an air furnace by bringing the furnace

temperature to 800°C and left in the furnace until cooled. The epoxy specimens were cut from the vacuum degassed surplus epoxy from the coil potting.

#### Apparatus

The sample is inserted into a loose-fitting, U-shape, stainless steel block, Figs. 1 and 2. The load is applied with a stainless steel plunger. Quartz rods transmit the positions of the block and plunger to the body and piston, respectively, of a linear variable differential transformer (LVDT), which is at room temperature, Fig. 3.

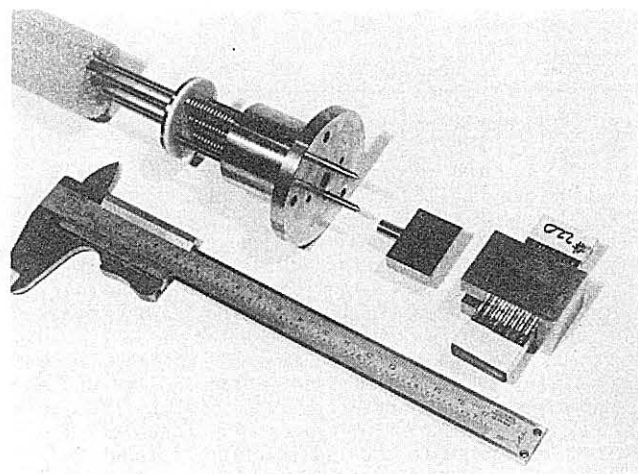

Fig. 1. Sample, compression plunger, and strain measuring rods. Photo shows a Nb-Ti bundle specimen from a previous test series.

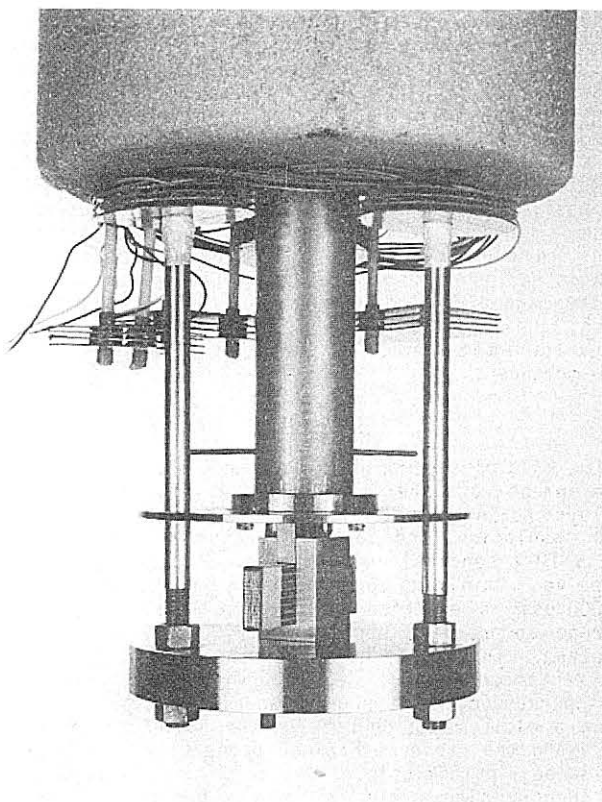

Fig. 2. Closeup of sample in compression apparatus.

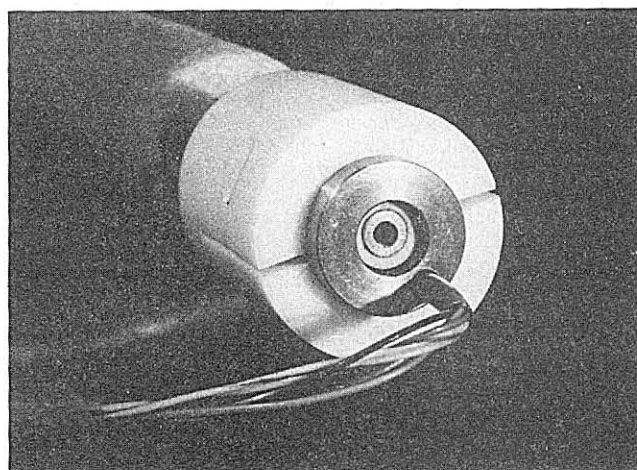

Fig. 3. LVDT - Transformer and core at upper end of strain measuring rods.

Testing is performed in a dewar installed in an Instron universal testing machine having a capacity of 5000 lb. (22 kN), Fig. 4. Signals from the LVDT



Fig. 4 Mechanical facility for compression and thermal tests (400 to 4 K).

and load cell are recorded and processed by an HP85A desktop computer (Fig. 4). The compression stages of the tester are built rather lightly to allow for operation at liquid helium temperature, and there are some apparatus deflections which contribute to the strain readings. The apparatus deflections were measured by tests using a steel specimen and are subtracted out by the computer.

### Results

In the  $Nb_3Sn$  coil specimens, plastic flow begins at practically zero stress and is large, reaching 2% at 15 kpsi (103.4 MPa). Load cycles below a previously applied stress are reasonably elastic. After the tests the specimens showed no apparent macroscopic damage even after loading to 20 kpsi (enclosed specimens). The lateral expansion strain resulting from a "perpendicular" (to the broad face of the conductor) stress amounts to more than half of the direct compression strain. The longitudinal strain is much less but could be a significant design factor: in a 5 m magnet the effect of pre-compression to 10 kpsi would increase the coil length 1 cm. This data offers the possibility that pre-loading a coil in the perpendicular direction could achieve preload in the other 2 axes. See Fig. 5a,b,c.

Figure 6 shows that plastic flow reappears at 77 K even after the specimen was previously stressed to 15 kpsi. The dashed line on the graph represents the cooldown process. The thermal contraction from 300 to 77 K at any stress level is measured horizontally

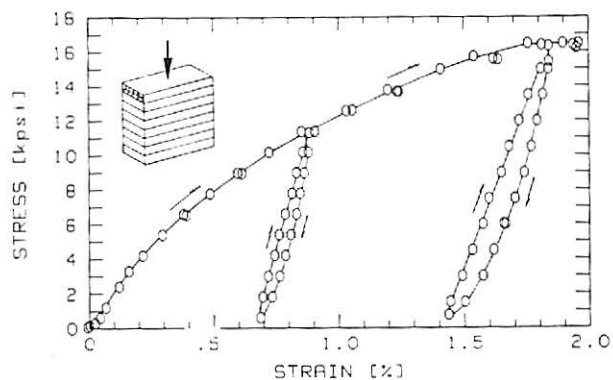

Fig. 5a. Stress-strain perpendicular to the broad face of the conductor.

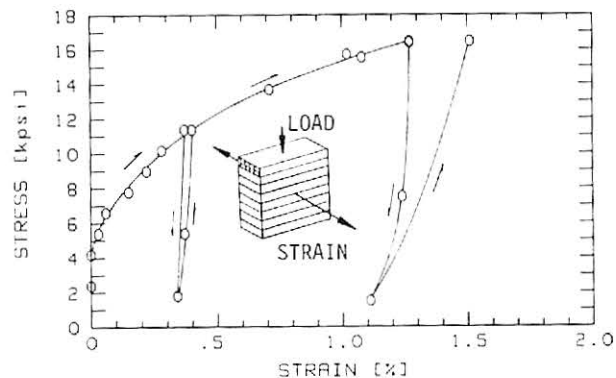

Fig. 5b. Lateral strain as a result of the applied stress shown in Fig. 5a.

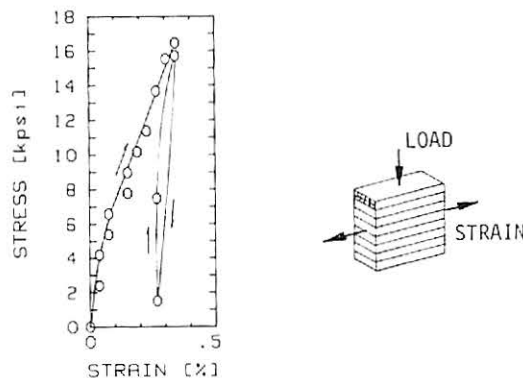

Fig. 5c. Longitudinal strain as a result of the applied stress shown in Fig. 5a.

between the 300 and 77 K segments of the graph provided the material is elastic or the stress is held constant during cooldown. At 2 kpsi the contraction is 0.36%. This is a better value than can be obtained from Fig. 9.

Enclosing the sample on all sides reduces the plastic strain at the higher stress levels. The hysteresis loops in the load cycles are apparently due to the room temperature behavior of the epoxy constituent plus friction with the enclosure. When the room temperature specimen, well-seated in the enclosure by testing to 20 kpsi, was cooled to 77 K

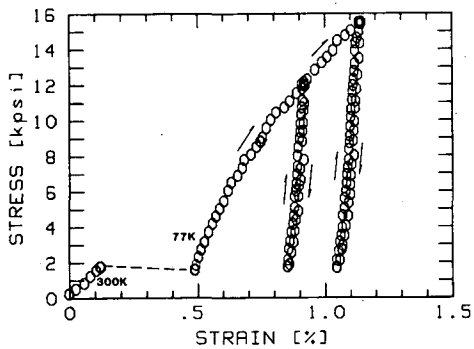

Fig. 6. Perpendicular stress-strain and cooldown from 300 to 77 K of a sample previously tested to 15 kpsi at 295 K.

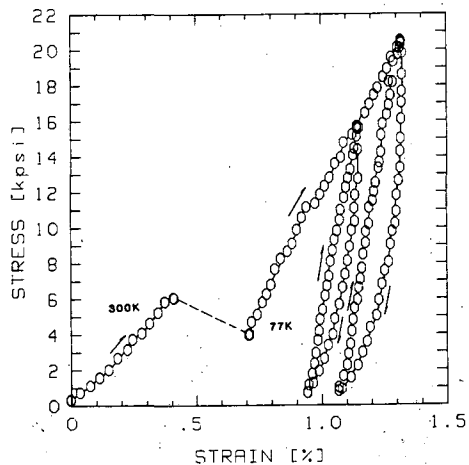

Fig. 9. Perpendicular stress-strain and cooldown from 300 to 77 K on virgin sample fully enclosed.

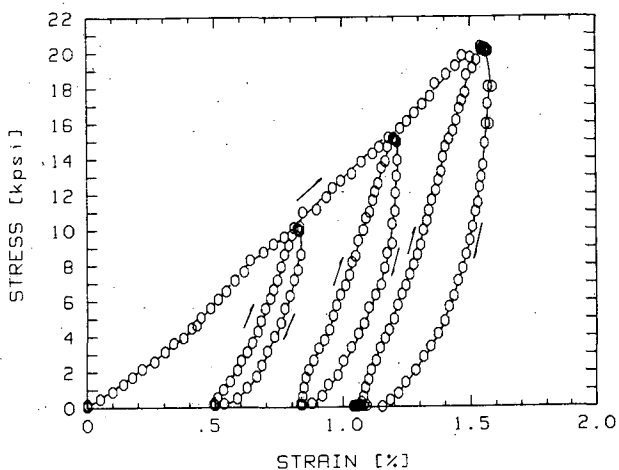

Fig. 7. Perpendicular stress-strain in a fully enclosed sample (300 K).

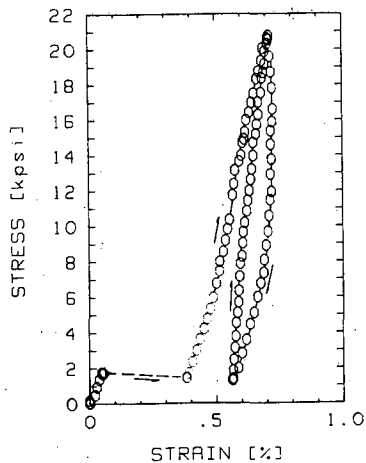

Fig. 8. Perpendicular stress-strain at 77 K in a fully enclosed sample (same sample as previously used for Fig. 7).

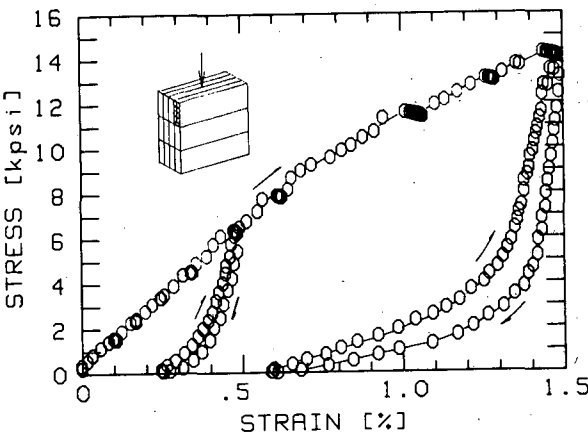

Fig. 10. Stress-strain perpendicular to the narrow face of the conductor.

When the stress-strain slopes are steep, a small error in strain measurement, of the order of the calibration correction makes a large error in calculating a value of Young's modulus. Therefore the graphs should not be used to estimate Young's modulus for values  $>4$  or  $5$ . Our best estimates of the slopes of the last load cycles with rising stress are  $3.5 \times 10^6$  psi at 300 K and  $6 \times 10^6$  psi at 77 K. These values were not affected by the rigid enclosure, probably due, in part at least, to



uncontrolled voids within the sample or the fit of the sample.

All of the room temperature measurements show evidence of creep at stresses >10 kpsi.

Two shear tests were made to measure the epoxy-to-copper bond along the direction of the conductor. The rupture strengths were found to be 500 and 900 psi, indicating the need for improved surface treatment.

The test of annealed OFHC copper, Fig. 11, shows a yield point (0.5 offset) of about 5 kpsi, much lower than the 10 kpsi usually quoted.

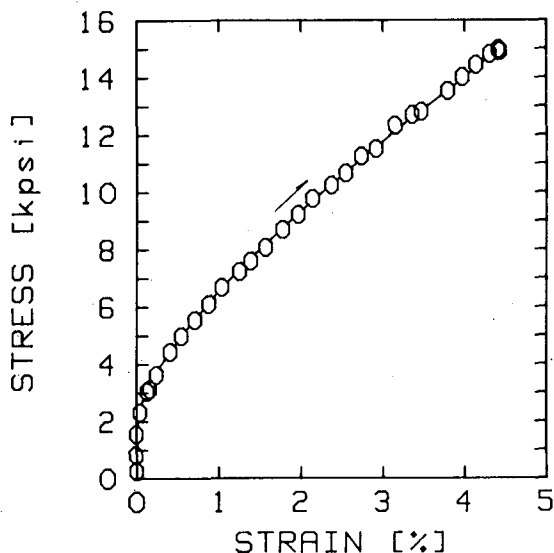

Fig. 11. Stress-strain of annealed OFHC copper.

The test of pure epoxy at 300 K, Fig. 12, shows elastic behavior to 10 kpsi with Young's modulus of  $5 \times 10^5$  psi, unlimited creep at 15 kpsi, a big hysteresis loop, but surprising strength recovery after a total strain of 9%. At 77 K, Fig. 13, the epoxy was elastic to 21.5 kpsi (the limit of the tester; there was no failure of the epoxy) with Young's modulus of  $1.2 \times 10^6$  psi. The thermal contraction from 300 to 77 K was 0.8%.

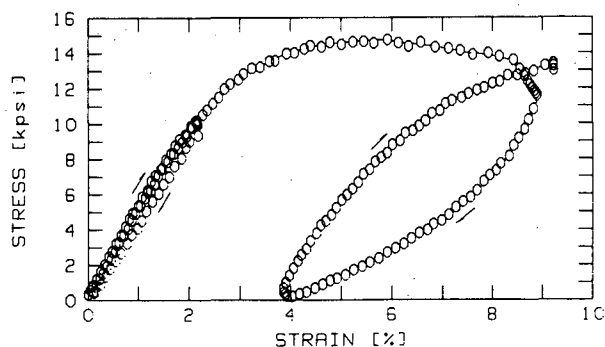

Fig. 12. Stress-strain of pure epoxy at 300 K.

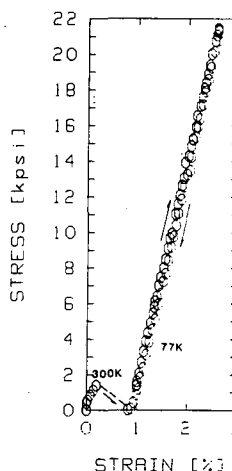

Fig. 13. Stress-strain and cooldown from 300 to 77 K of pure epoxy.

References

1. R. B. Meuser, S. Caspi, W. S. Gilbert, "Measured Mechanical Properties of Superconducting Coil Materials and their Influence on Coil Prestress". IEEE Trans. Mag., Vol. MAG-17, 5, pp. 2320-2323, 1981.

This report was done with support from the Department of Energy. Any conclusions or opinions expressed in this report represent solely those of the author(s) and not necessarily those of The Regents of the University of California, the Lawrence Berkeley Laboratory or the Department of Energy.

Reference to a company or product name does not imply approval or recommendation of the product by the University of California or the U.S. Department of Energy to the exclusion of others that may be suitable.

TECHNICAL INFORMATION DEPARTMENT  
LAWRENCE BERKELEY LABORATORY  
UNIVERSITY OF CALIFORNIA  
BERKELEY, CALIFORNIA 94720