

# Lawrence Berkeley National Laboratory

## Lawrence Berkeley National Laboratory

**Title**

Conceptual Design of A 1-2 GeV Synchrotron Radiation Source

**Permalink**

<https://escholarship.org/uc/item/1m70b6qw>

**Author**

The 1-2 GeV Synchrotron Radiation Source Design St

**Publication Date**

1986-08-01



# Lawrence Berkeley Laboratory

UNIVERSITY OF CALIFORNIA

RECEIVED  
LAWRENCE  
BERKELEY LABORATORY

## Accelerator & Fusion Research Division

OCT 2 1986

LIBRARY AND  
DOCUMENTS SECTION

Presented at the 13th International Conference on  
High Energy Accelerators, Novosibirsk, USSR,  
August 7-11, 1986

CONCEPTUAL DESIGN OF  
A 1-2 GeV SYNCHROTRON RADIATION SOURCE

The 1-2 GeV Synchrotron Radiation Source Design Staff

August 1986

**TWO-WEEK LOAN COPY**

*This is a Library Circulating Copy  
which may be borrowed for two weeks.*

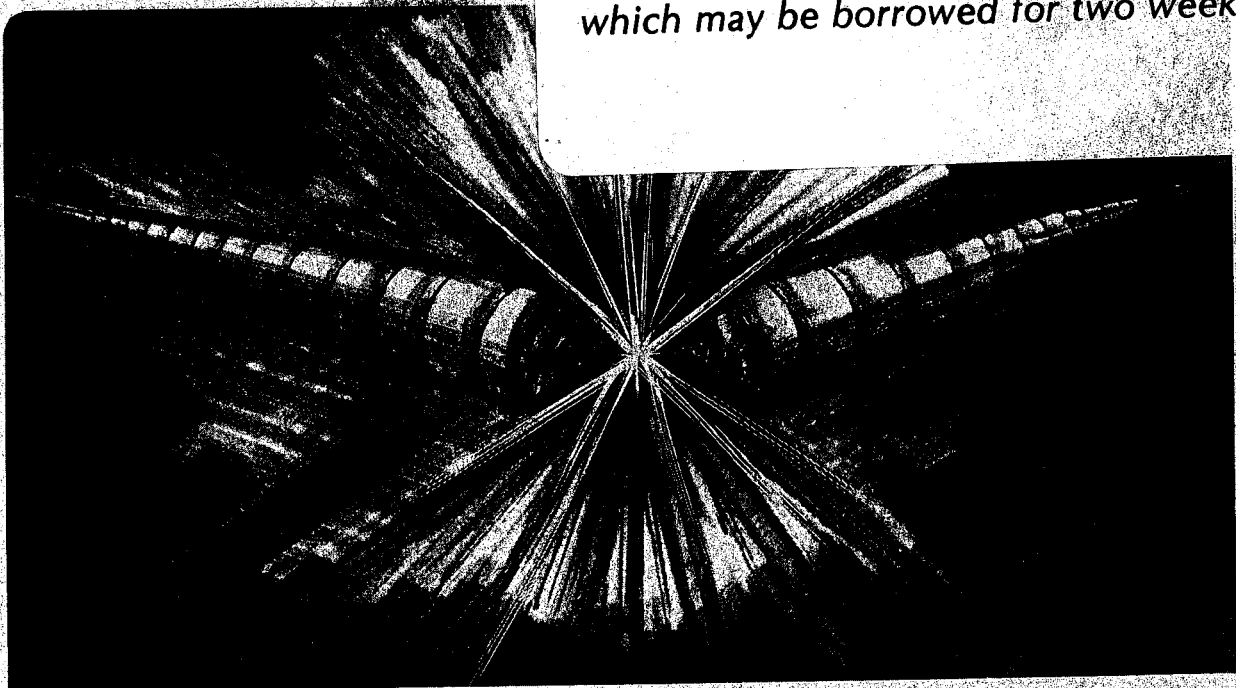

c.2

LBL-21390  
c.2

CONCEPTUAL DESIGN OF A 1-2 GeV SYNCHROTRON RADIATION SOURCE\*

The 1-2 GeV Synchrotron Radiation Source Design Staff

Lawrence Berkeley Laboratory  
University of California  
Berkeley, CA 94720

August 1986

\*This work was supported by the Office of Basic Energy Sciences of the U.S. Department of Energy, under Contract No. DE-AC03-76SF00098.

# CONCEPTUAL DESIGN OF A 1-2 GeV SYNCHROTRON RADIATION SOURCE\*

The 1-2 GeV Synchrotron Radiation Source Design Staff  
Lawrence Berkeley Laboratory  
University of California  
Berkeley, California 94720, USA

Presented by M. Cornacchia

## Abstract

A description is presented of the conceptual design of the Lawrence Berkeley Laboratory 1-2 GeV Synchrotron Radiation Source, which is designed to produce ultraviolet and soft x-ray radiation. The facility consists of an injection system (linac plus booster synchrotron), a low emittance storage ring optimized at 1.5 GeV, several insertion devices (wigglers and undulators) located in the storage ring straight sections, and beam lines from the insertion devices and bending magnets. Storage ring performance is analyzed in terms of lattice, collective instabilities and beam lifetime. The injection system and its performance are discussed. Spectral characteristics of the radiation are presented.

## 1. Introduction

The Lawrence Berkeley Laboratory has designed a synchrotron radiation facility for the production of high-brightness photon beams in the energy range from a few eV to several keV. The 1-2 GeV Synchrotron Radiation Source consists of low-emittance storage ring optimized for insertion devices and for operation at 1.5 GeV. Eleven straight sections are available for undulators and wigglers, and up to 48 photon beam lines may ultimately emanate from bending magnets. Design features of the storage ring are the very low horizontal electron beam emittance ( $4 \times 10^{-9}$  m-rad, rms value), the short bunch length (20-50 ps, rms value), and the tunability of the radiation. The design accommodates the requirements of a broad range of scientific disciplines, including atomic and molecular physics, biology and medicine, chemical dynamics, materials and surface science, and industrial research and technology.

## 2. General Description of the Facility

The 1-2 GeV Synchrotron Radiation Source consists of an injection system (linac plus booster synchrotron), a low-emittance storage ring optimized at 1.5 GeV (maximum energy 1.9 GeV), several insertion devices located in the

storage ring straight sections, and beam lines from the insertion devices and bending magnets. The major parameters of the Light Source are given in Table 1.

## Lattice Design and Single Particle Dynamics

The layout of one of the storage ring superperiods is shown in Fig. 1. Each superperiod has reflection symmetry around a central dipole and consists of a "dispersive region", where the bending occurs, matched to a straight section, 6.75 m long, reserved for undulators, wigglers, injection hardware and radio-frequency cavities. The straight sections are dispersion free, and the optics functions are optimized for brightness. The lattice achieves a very small emittance ( $4 \times 10^{-9}$  m-rad) with moderate focusing. This structure, called a "triple-bend achromat" because it incorporates three bending dipoles per superperiod, was first proposed by G. Vignola for a 6-GeV light source.<sup>1</sup>

Figure 2 shows the lattice functions in a superperiod of the accelerator. Figure 3 gives the momentum-dependent tune shifts. The momentum acceptance of the lattice, of the order of  $\pm 4\%$  in  $\Delta p/p$ , gives a Touschek lifetime of the order of 18 hours when the ring is filled with a current of 400 mA. Only two families of sextupoles are required for chromaticity correction.

The dynamic half-aperture of the machine is 23 mm in the horizontal plane (at  $\beta_x = 11$  m) and 10 mm in the vertical plane (at  $\beta_y = 4$  m). The presence of magnetic imperfections in the magnets reduces the dynamic aperture to 18 mm horizontally and 9 mm vertically. This aperture is comfortably larger than the minimum needed for multiturn injection in the radial plane and for a long beam lifetime.

## RF Choice and Collective Effects

The achievement of short bunches is a design goal of the Light Source, since this is a very desirable feature for many users. In practice, the attainable bunch length is determined by the rf parameters and the constraints of the longitudinal microwave instability. A high frequency favors short bunches, and for this reason, 500 MHz was chosen.

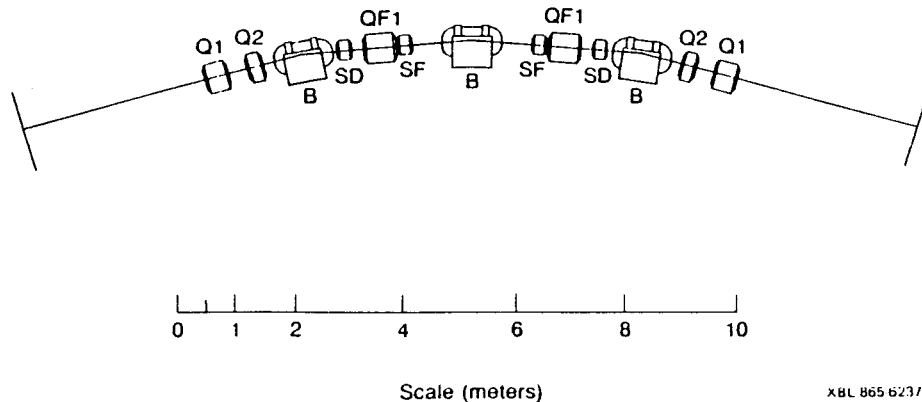

Fig. 1. One unit cell of the TBA structure.

\*This work is supported by the Office of Basic Energy Sciences of the U.S. Department of Energy under Contract No. DE-AC03-76SF00098.

Table 1. Summary of major storage ring parameters<sup>a</sup>

Nominal energy (GeV)	1.5
Maximum circulating current, multibunch (mA)	400
Maximum circulating current, single bunch (mA)	7.6
Natural horizontal emittance (m-rad) <sup>b</sup>	$4.08 \times 10^{-9}$
Bunch length (ps), ( $2\sigma$ ) at maximum current	
Multibunch (ps)	28
Single bunch (ps)	47
Peak energy (GeV)	1.9
Beam lifetime, half-life	
Gas scattering <sup>c</sup> (hr)	10.5
Touschek, maximum current	
Multibunch (hr)	18.5
Single bunch (hr)	8.4
Filling time	
Multibunch, to 400 mA (min)	2.1
Single bunch, to 7.6 mA per bunch (s)	16
Circumference (m)	196.8
Orbital period (ns)	656.4
Harmonic number	328
Radio frequency (MHz)	499.654
Peak effective rf voltage (MV)	1.5
Number of superperiods	12
Insertion straight section length (m)	6.75
Length available for insertion device (m)	5.0
Bending field (T)	1.248
Injection energy (GeV)	1.5
Betatron tunes	
Horizontal	14.28
Vertical	8.18
Synchrotron tune	0.0082
Natural chromaticities	
Horizontal	-24.1
Vertical	-28.5
Beta functions at insertion symmetry points	
Horizontal (m)	11.0
Vertical (m)	4.0
Momentum compaction	$1.43 \times 10^{-3}$
Damping times	
Horizontal (ms)	13.1
Vertical (ms)	17.6
Longitudinal (ms)	10.7
Number of sextupole families	2

<sup>a</sup> All parameters at nominal energy unless otherwise noted.

<sup>b</sup> Defined as  $\epsilon = \sigma^2/\beta$ , where  $\sigma$  is the rms beam size and  $\beta$  the amplitude function.

<sup>c</sup> 10-mm vertical gap, 1 n Torr N<sub>2</sub>

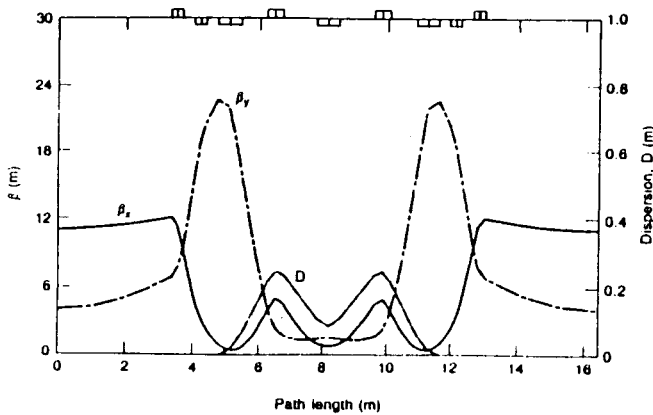

Fig. 2. Lattice functions through one unit cell of the TBA structure.

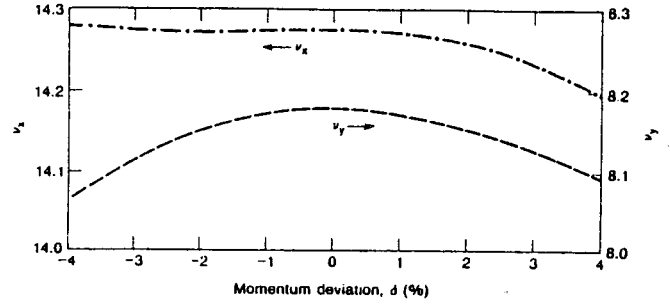

Fig. 3. Momentum-dependent tune shifts

For this frequency, there are well-proven cavity designs at various accelerator centers (KEK, BESSY, Daresbury, DESY). The influence of the longitudinal microwave instability is determined by the effective impedance assumed for the ring. Figure 4 shows the expected bunch length as a function of the circulating current. It is expected that the effective longitudinal impedance will decrease for bunch lengths which are shorter than the pipe radius, as was determined experimentally at SPEAR.<sup>2</sup> Accordingly, Fig. 4 shows two curves, one that assumes SPEAR scaling and one that does not.

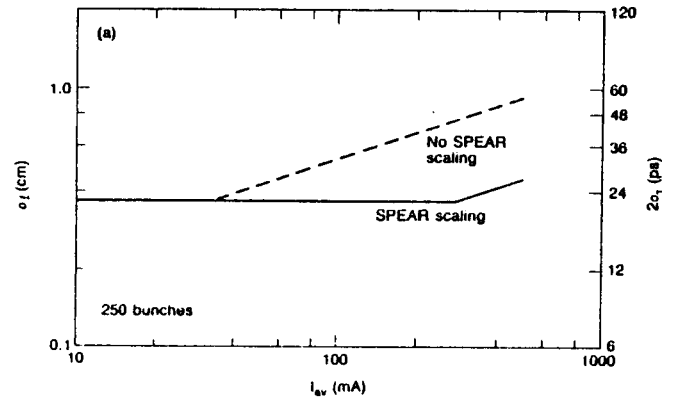
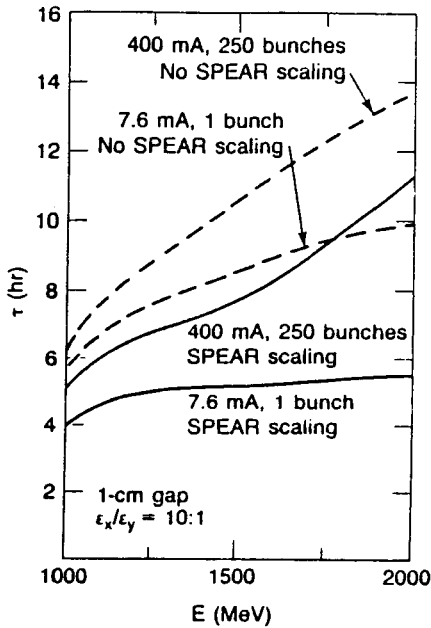

Fig. 4. Bunch length vs. current at 1.5 GeV, with and without the SPEAR scaling law, for the 250-bunch case.

The beam coupling impedance has been estimated by taking into account the contributions of the rf system, the geometry of the vacuum chamber (see also the discussion of the vacuum system, below), and the effect of chamber discontinuities due to narrow-gap insertion devices. For 2-cm-gap undulators, microwaves at frequencies above 8 GHz will propagate through the tube, thus having a small effect on the impedance seen by the beam. For a 1 cm gap, the cutoff frequency increases to 16 GHz, and effects due to the single-bunch instability begin to become significant.

Intrabeam scattering will have a negligible effect on emittance growth at the nominal energy of 1.5 GeV. Large-angle intrabeam scattering, however, does affect the lifetime of the beam (Touschek effect). The other physical phenomenon that determines the lifetime of the beam is gas scattering. In order to accommodate undulators gaps as small as 1.4 cm, corresponding to a beam aperture of 1 cm, a vacuum of  $1 \times 10^{-9}$  Torr is a design goal. The predicted overall beam lifetime is shown in Fig. 5 for single-bunch (higher peak current) and multibunch scenarios, assuming a lifetime aperture of 1 cm.



XBL 865 6224

Fig. 5. Predicted overall beam lifetimes for single-bunch and multibunch scenarios, assuming an undulator gap of 1 cm.

Vacuum System

A major obstacle to the achievement of the design goal of  $1 \times 10^{-9}$  Torr is the desorption of molecules from the chamber walls. This is caused by photoelectrons, which are created by photons hitting the walls. LBL has developed a new approach to this problem, illustrated by the vacuum chamber configuration shown in Fig. 6. The electron beam circulation region is connected by a long, continuous slit to an antechamber, which contains discrete water-cooled synchrotron radiation absorbers. The gas is generated at these absorbers, which are located directly above the titanium sublimation pump. Measurements and computations show that the presence of the antechamber has a negligible effect on the beam coupling impedance. This is because the antechamber contributes only above the cutoff frequency of the slot (about 10 GHz). At these frequencies, the waves propagate freely in the beam tube.

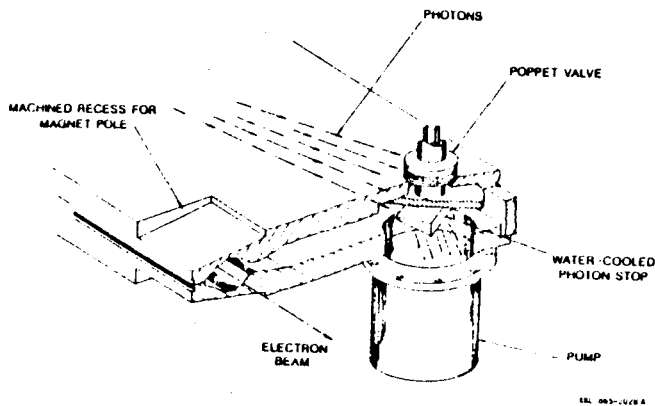

XBL 865-1024

Fig. 6. Cutaway view of the Light Source vacuum chamber, showing a photon stop and titanium sublimation pump.

Magnet System

The ring magnets consist of gradient bending magnets, quadrupoles, sextupoles, skew quadrupoles, small dipole magnets for orbit correction, and special septum and bump magnets for injection. The magnets are of a C configuration to permit easy extraction of synchrotron radiation and to accommodate the vacuum chamber. Figures 7 and 8 show the designs of the gradient bending magnets and the quadrupoles. The sextupoles incorporate the skew quadrupoles and the correcting dipole circuits as well. Special steering dipoles for correcting the orbit in the insertion region are also provided.

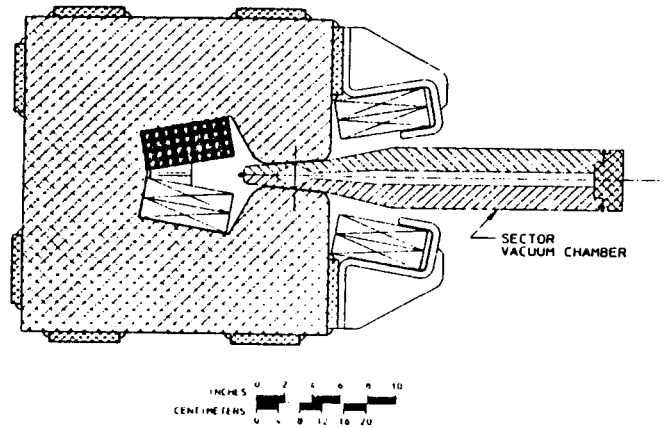

XBL 865-2037 A

Fig. 7. Storage ring bending magnet cross section, including a close-up view of the pole area.

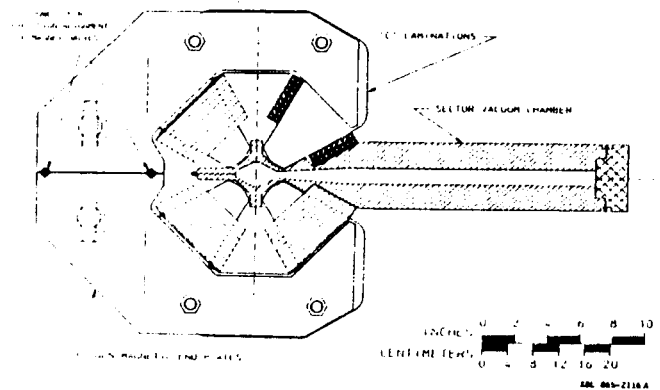

XBL 865-2316 A

Fig. 8. Storage ring quadrupole magnet cross section

Storage Ring Electrical System

The 36 gradient bending magnets in the storage ring are electrically connected in series and powered by a single power supply consisting of a 12-phase rectifier with an LC filter and a series transistor bank. The 24 QF1 quadrupole magnets (see Fig. 1) are electrically connected in series to a single power supply of the same type. The remaining 48 quadrupole magnets (Q1 and Q2) are individually powered by separate supplies.

### Injection System

A layout of the injection system is shown in Fig. 9. A 50-MeV linac injects the bunches into a booster, where the energy of the beam is increased to 1.5 GeV. Injection at the nominal operating energy of the storage ring is desirable for reasons of ease of operation and reproducibility of the experimental conditions. (For those experiments requiring operation at 1.9 GeV, the beam energy will be ramped). The booster is a ring of 70-m circumference. Its lattice is a simple FODO structure accommodating 4 straight sections for injection, extraction and rf.

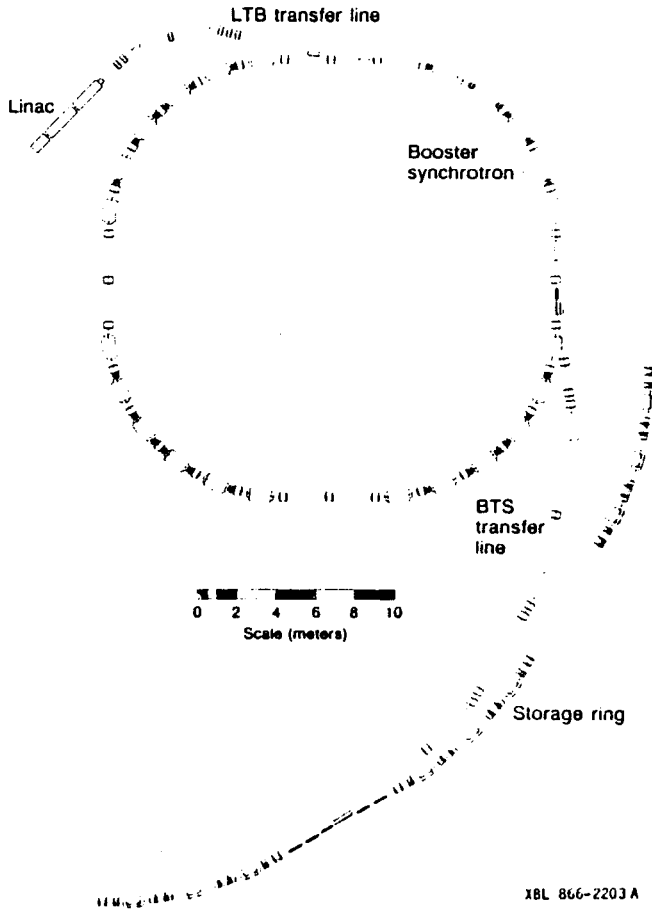

Fig. 9. Schematic diagram of the injection system layout.

There are two different operating scenarios. The multibunch operating mode requires that the storage ring be filled to a current of 400 mA in approximately 250 consecutive bunches (out of a total of 328; the gap is needed to avoid ion trapping). For the few bunch operating mode, we assume a current of 7.6 mA per bunch. In this mode, the bunches are filled one at a time. Filling times are 2.1 min in the multibunch mode and 16 sec per bunch in the single bunch mode.

### Control system

The computer control system provides a means for accessing all machine components, so that their values can be set and monitored remotely. To allow flexible control, a number of computer programs will be provided to the operator. The status of the machine devices will be displayed, with graphics where appropriate, and software

will be developed for archival storage and retrieval of machine parameters.

The control system will use a highly distributed, microprocessor-based architecture that is bus-based and features parallel processing and a distributed data base. The major benefits of this architecture are improved system response time, simplification of the programming effort, and adaptability to future development.

### 3. Photon Performance

There are 11 straight sections in the storage ring devoted to insertion devices; in each straight section 5 m is available for insertion devices. The initial construction program includes four undulators and one wiggler. The characteristics of these insertion devices are given in Table 2, and their performance is shown in Fig. 10, which depicts the high photon brightness achievable at this facility. The Light Source is optimum for the production of undulator photons in the nominal energy range from 1 to 1000 eV.

### 4. Beam lines

The extraordinary performance of the 1-2 GeV Synchrotron Radiation Source with regard to brightness generates opportunities for many new types of scientific investigations. The optical systems must perform in such a way that no phase-space smearing occurs, and they must work in the presence of considerable photon beam power. The optical surface tolerances involved are around one microradian and require careful design and fabrication strategies.

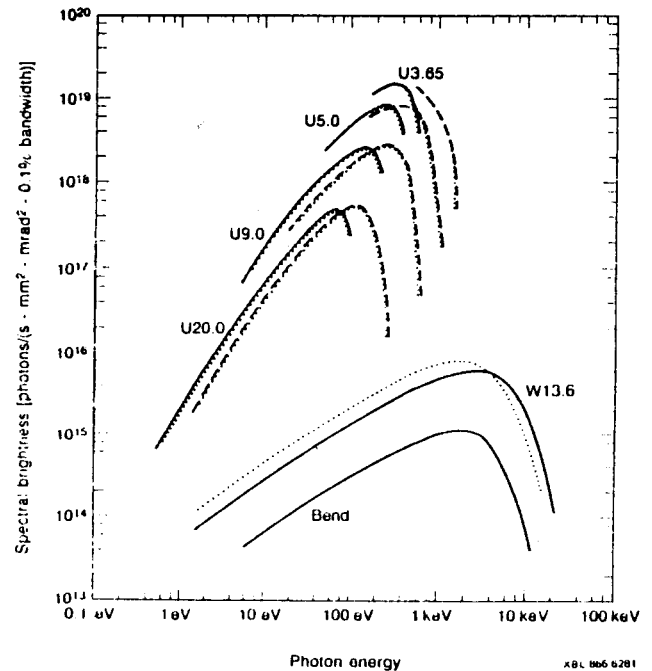

Fig. 10. Spectral brightness as a function of energy for the four undulators and one wiggler described in Table 2, together with the bending magnets for the Light Source. For the undulators, the tuning range is shown for both the fundamental (solid lines) and the third harmonic (dashed lines). The dotted lines show corresponding curves for spectral brightness at commissioning, when the minimum magnet gap will be 2.5 cm.

Table 2. Parameters for the initial complement of insertion devices chosen for the Light Source.

Name	Period (cm)	No. of Periods	Photon Energy Range (eV) <sup>a</sup>	Critical Energy (keV)
<u>Undulators</u>				
U20.0	20.0	23	0.5-9.5 [1.5-285]	-
U9.0	9.0	53	5-211 [15-633]	-
U5.0	5.0	98	50-380 [150-1140]	-
U3.65	3.65	134	183-550 [550-1650]	-
<u>Wiggler</u>				
W13.6	13.6	16	-	3.1

<sup>a</sup>The photon energy range of the fundamental and the third harmonic (shown in brackets) as K decreases from its maximum value to 0.5.

An important feature of the optical systems is their phase-space acceptance. With the presently achievable phase-space properties of state-of-the-art monochromators adjusted for high resolution (narrow slits), it has not hitherto been possible to accept more than a small fraction of the beam from the source. With the proposed Light Source, however, the low source emittance promises a total system that delivers photons at 1 keV with bandwidth of  $10^{-4}$  without the loss of photons due to phase space-mismatch.

### 5. Summary

The 1-2 GeV Synchrotron Radiation Source proposed by Lawrence Berkeley Laboratory is a third generation synchrotron radiation facility optimized for insertion devices. The design concepts emphasize high spectral brightness from undulators, high flux from wigglers, picosecond time structure, and a capability to accommodating many beam lines. The engineering and accelerator physics aspects, although challenging, are within reach of the available technology and the present understanding of beam dynamics issues.

### References

1. G. Vignola, "Preliminary Design of a Dedicated 6 GeV Synchrotron Radiation Storage Ring," Nucl. Instrum. Methods., A236 (1985) 414.
2. A.W. Chao and J. Gareyte, "Scaling Law for Bunch Lengthening in SPEAR II," PEP-224, December 1976.