

Lawrence Berkeley National Laboratory

Recent Work

Title

A QUANTITATIVE STUDY OF PHOTOSYNTHESIS ON A MOLECULAR LEVEL

Permalink

<https://escholarship.org/uc/item/1n53m716>

Author

Wilson, Alexander Thomas.

Publication Date

1954-05-01

UCRL 2589
UNCLASSIFIED

UNIVERSITY OF
CALIFORNIA

*Radiation
Laboratory*

TWO-WEEK LOAN COPY

*This is a Library Circulating Copy
which may be borrowed for two weeks.
For a personal retention copy, call
Tech. Info. Division, Ext. 5545*

BERKELEY, CALIFORNIA

DISCLAIMER

This document was prepared as an account of work sponsored by the United States Government. While this document is believed to contain correct information, neither the United States Government nor any agency thereof, nor the Regents of the University of California, nor any of their employees, makes any warranty, express or implied, or assumes any legal responsibility for the accuracy, completeness, or usefulness of any information, apparatus, product, or process disclosed, or represents that its use would not infringe privately owned rights. Reference herein to any specific commercial product, process, or service by its trade name, trademark, manufacturer, or otherwise, does not necessarily constitute or imply its endorsement, recommendation, or favoring by the United States Government or any agency thereof, or the Regents of the University of California. The views and opinions of authors expressed herein do not necessarily state or reflect those of the United States Government or any agency thereof or the Regents of the University of California.

UCRL-2589

Unclassified-Chemistry Distribution

UNIVERSITY OF CALIFORNIA

Radiation Laboratory

Contract No. W-7405-eng-48

A QUANTITATIVE STUDY OF PHOTOSYNTHESIS
ON A MOLECULAR LEVEL

Alexander Thomas Wilson

May, 1954

Berkeley, California

TABLE OF CONTENTS

	Page No.
ABSTRACT	
ABBREVIATIONS	
INTRODUCTION.	1
EXPERIMENTAL PROBLEMS IN THE QUANTITATIVE STUDY OF PHOTOSYNTHESIS.	6
Experimental techniques.	6
Problem of non-reproducibility of algal cultures.	6
The apparatus	6
Illumination vessel.	12
General considerations	15
CO ₂ infrared gas analyzer.	15
Extraction of phosphates from algae	19
Absorption of phosphorylated compounds on plant materials	19
The "octopus"	20
Chromatography	23
Introduction.	23
Chromatographic techniques.	23
Solvents	23
Paper.	29
Types of paper.	29
Washing papers.	29
Preequilibration of papers.	31
The use of thick paper.	34

TABLE OF CONTENTS
continued

Quantitative techniques in chromatography.	34
Basic assumption.	34
Direct paper counting of spots.	35
Origin sticking	35
New technique for secondary separation of phosphorylated compounds.	36
Chromatographic theory.	40
Double spots	40
The chelate type.	40
The distribution type	40
Origin reflection type.	42
Double ribulose diphosphate spots	42
APPLICATION OF TECHNIQUES.	43
Determination of experimental parameters.	44
CO ₂ pressure change.	44
Rate of gas flow during transition period.	44
Temperature.	44
Geometric saturation	49
Light saturation	49
Sampling.	50
Processing of points.	50
Experimental procedure.	51
RESULTS.	54

TABLE OF CONTENTS
continued-3

DISCUSSION.	60
General effects.	60
CO ₂ incorporation step	60
Relationships of the intermediates in the regenerative cycle as derived from transient phenomena.	63
Period of the regenerative cycle	67
Criteria of a photosynthetic intermediate.	67
Evidence for transketolase system.	68
Other effects.	70
Conclusion	74
APPENDICES.	75
Aliquoting compounds	76
Glucose and galactose cyclic phosphates.	77
Degradation of ribulose diphosphate.	78
Non-enzymatic fixation of CO ₂ - storage of RDP	79
35-cent oxygen analyzer.	79
REFERENCES.	81

ABBREVIATIONS

The following abbreviations will be used throughout this thesis:

ATP	adenosine triphosphate
DHAP	dihydroxyacetone phosphate
FMP	fructose monophosphate
PGA	phosphoglyceric acid
RDP	ribulose diphosphate
RMP	ribulose monophosphate
UDPG	uridine diphosphate glucose (galactose)

A QUANTITATIVE STUDY OF PHOTOSYNTHESIS
ON A MOLECULAR LEVEL

Alexander Thomas Wilson

Radiation Laboratory and Department of Chemistry
University of California
Berkeley

ABSTRACT

Techniques have been developed and an apparatus has been designed and constructed to make possible quantitative experiments in photosynthesis. It is now possible to measure the amounts of the photosynthetic intermediates as a function of external variables such as partial pressure of CO_2 and O_2 , light, temperature, pH, poisons, and various combinations of these.

Use has been made of the above techniques to study the transient changes taking place when the CO_2 pressure is varied and these results have led to the development of the concept of fluctuating reservoir sizes. These data have also provided the first unequivocal evidence of the relation of phosphoglyceric acid and ribulose diphosphate to the CO_2 incorporation step. Ribulose diphosphate has been identified as being closely related to, if not actually, the CO_2 acceptor and phosphoglyceric acid as being the product of the carboxylation. The data shows that ribulose monophosphate and triose phosphate are also in the cycle which regenerates the CO_2 acceptor, and provides us with the precursor-product relationships between the compounds in this cycle. The kinetics of free glycolic acid provide strong evidence of the presence of a

transketolase enzyme system which transfers an unphosphorylated glycolyl fragment. Perhaps the most important result of this work is the insight it gives into the complicated, finely-balanced, system of interrelated chemical reactions we call life.

A QUANTITATIVE STUDY OF PHOTOSYNTHESIS

ON A MOLECULAR LEVEL

Alexander Thomas Wilson

Radiation Laboratory and Department of Chemistry
University of California
Berkeley, California

May, 1954

INTRODUCTION

Photosynthesis is the process by which green plants utilize light quanta to convert CO_2 and water to carbohydrate. It is without doubt the largest and most important chemical industry taking place on the surface of our earth and is the mechanism by which the thermo-nuclear energy of the sun is trapped in a form available to life processes. Without photosynthesis, life as we know it on the surface of our planet would have succumbed to oxidation and perished long ago.

Because of its importance and the multitude of its manifestations, photosynthesis was one of the first chemical processes investigated by modern science, research in this field dating back almost to the beginning of modern chemistry itself. Rapid progress was made at first, and during the last thirty years of the 18th century, due to the brilliant work of Priestley, Ingen-Housz, Senebier and de Saussure, the overall net reaction was worked out as:

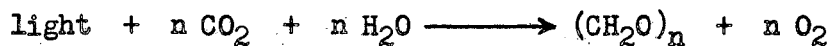

Little real progress was made in the elucidation of the mechanism for the next 130 years. However, in the 1930's the development in ingenious

physical instruments enabled the quantitative investigation of the overall reaction of photosynthesis. Induction phenomena in CO₂ uptake, fluorescence phenomena, quantum yields, etc. have been investigated in great detail over the last 20 years^{1,2,3,4,5} and many interesting and puzzling facts have been uncovered. Since the workers in this field are forced to work with an intact cell, they can only measure changes in the overall reaction of the cell. Their results, although interesting, are very difficult to interpret at our present state of knowledge and are thus of little help in elucidating the mechanism of photosynthesis.

The discovery of the isotopes of carbon and oxygen during the last two decades have provided a tool by means of which the fate of certain atoms could be traced as they underwent the multitude of chemical transformations inside the living cell. Ruben, et al.,⁶ using isotopic oxygen, demonstrated that the evolved oxygen originated from the water rather than the CO₂. This work together with that of Hill^{7,8} led to the idea that photosynthesis could be divided into two distinct reactions, the first being the photolysis of water to yield oxygen gas and reducing power:

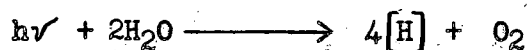

and the second involving the reduction of CO₂ to carbohydrate:



With the advent of C¹⁴, research concerning the mechanism of this second reaction became possible,^{9,10,11,12} but the 20-minute half life of this

isotope made experiments difficult. After 1946, C^{14} with its 5000-year half life, became available in large quantities, which made more elaborate experiments possible.^{13,14,15,16,17} Progress, however, was still slow since the complex mixtures of compounds extracted from the plant proved to be too intractable to be of any real value.^{13,14,15} The answer was provided by the development of paper chromatography by Martin and Synge.¹⁸ By developing techniques using C^{14} as a tracer and paper chromatography as a means of separation, Benson, Calvin and co-workers isolated and identified many of the intermediates in photosynthesis.¹⁷ The degradation of partially labeled intermediates^{19,20,21} gave valuable information about the path of an individual carbon atom and also about the relationships between intermediates. While these qualitative tracer experiments have led to the elucidation of many of the intermediates in the path of carbon in photosynthesis, they have also shown that in the study of photosynthesis, one is dealing with a complicated network of reactions which would be difficult, if not impossible, to elucidate by qualitative means alone. Thus in photosynthesis, as in many other scientific investigations, a stage had been reached where little further information could be gained by qualitative experimentation. If further progress was to be made, techniques had to be developed to do really quantitative experiments. This is always a difficult transition to make in any science.

At first, attempts were made at drawing quantitative results from qualitative experiments. Benson and Kawaguchi²² studied the kinetics of $C^{14}O_2$ incorporation in photosynthesizing algae using the qualitative

techniques, but lack of controlled conditions make the interpretation of their results very difficult. Massini studied the effect of light and dark on the steady-state conditions in algae,²³ and here for the first time C^{14} activity was used as a method of assay rather than as a tracer. Massini's experiments were an enormous improvement over earlier experiments and some attempt was made to control the experimental conditions.

It is clear that in a cyclic system such as is believed to exist in photosynthesis, the rate of consumption of a compound is eventually related to its rate of formation. Thus any changes impressed on the cycle by changes in the external variables would eventually move around the cycle and tend to cancel out the original change. This self-compensating feature in a biological system enables it to successfully withstand changes in environmental conditions. It becomes clear, therefore, that the actual values of steady-state concentrations of the intermediates are the result of a very complicated set of circumstances, the unique solution of which involves an exact knowledge of all the intermediates, their sequence, the rate constants of each of the reactions and all of the other parameters of the system. Thus data on steady-state concentration of intermediates provides data which involves so many unknown variables that a unique interpretation presents a very difficult problem indeed. However, if one variable is changed suddenly and the early transient changes are investigated, a much simpler situation is being dealt with which is consequently also easier to interpret, since only the steps actually involving the variable are changed while the rest

of the network, for the first few seconds at least, remains unchanged. Before such data could be obtained more quantitative procedures had to be developed for the analysis of the photosynthetic intermediates in algal extracts. Apart from the developments that had to be made in quantitation, the measurements of transient changes was an experimental problem for which apparatus had to be designed and constructed. The work described in this thesis represents an attempt to develop the techniques to make such experiments possible.

It should be emphasized that these techniques are not limited to photosynthesis but have broad application to any in vivo biological process.

EXPERIMENTAL PROBLEMS IN THE QUANTITATIVE STUDY OF PHOTOSYNTHESIS

Experimental Techniques

Problem of non-reproducibility of algal cultures

In any study of a biological process one is faced with the choice of an organism with which to work. In the case of photosynthesis, the leaves of the higher plants offer one possibility but are difficult to handle and open to many objections inherent in their structure, as for example the influence of the stomata. Algae are a natural choice because they can be grown easily in a continuous culture and can be handled in much the same way as any liquid. However, even when every attempt is made to control the conditions under which they are grown, algae show daily variation in such properties as rates of CO₂ fixation and cell division. These considerations make it difficult to do experiments in which the results from different days must be compared on a quantitative basis. To overcome this difficulty the experiments have been designed to use samples withdrawn from the same alga suspension.

The apparatus

The apparatus (Figure 1) was designed to take small representative samples of algal suspension over short-time intervals from a system whose external variables were under complete control, and was made as versatile as possible so that it could be used in a great many different experiments. Use was made of recent advances in instrumentation to monitor continuously variables such as partial pressure of CO₂ and radioactivity. The apparatus itself (Figure 2) consists of an illumination vessel "A" and three gas systems. One is a recycling system

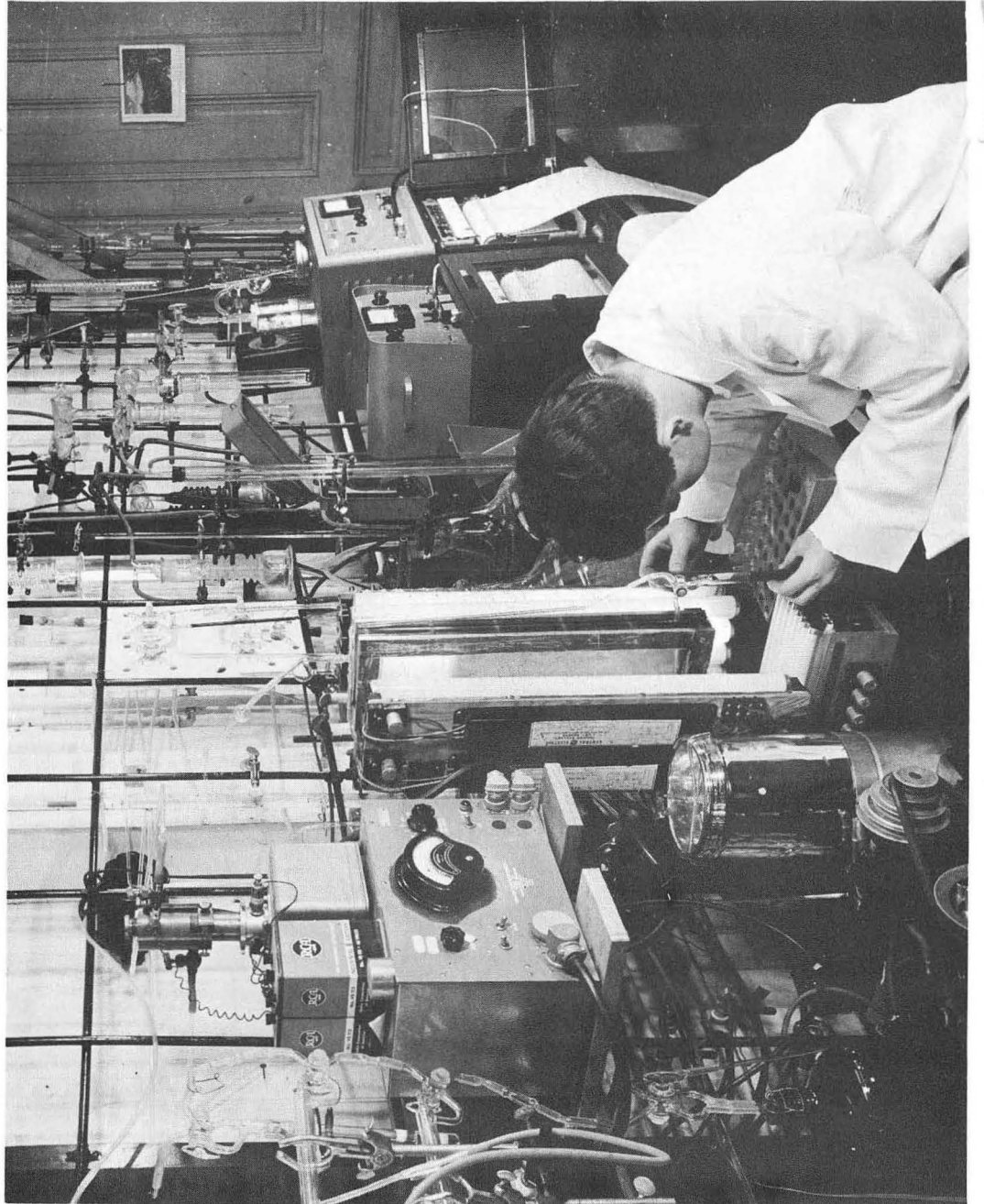

ZN-959

Fig. 1. Photograph of apparatus for measuring transient phenomena and changes in steady state.

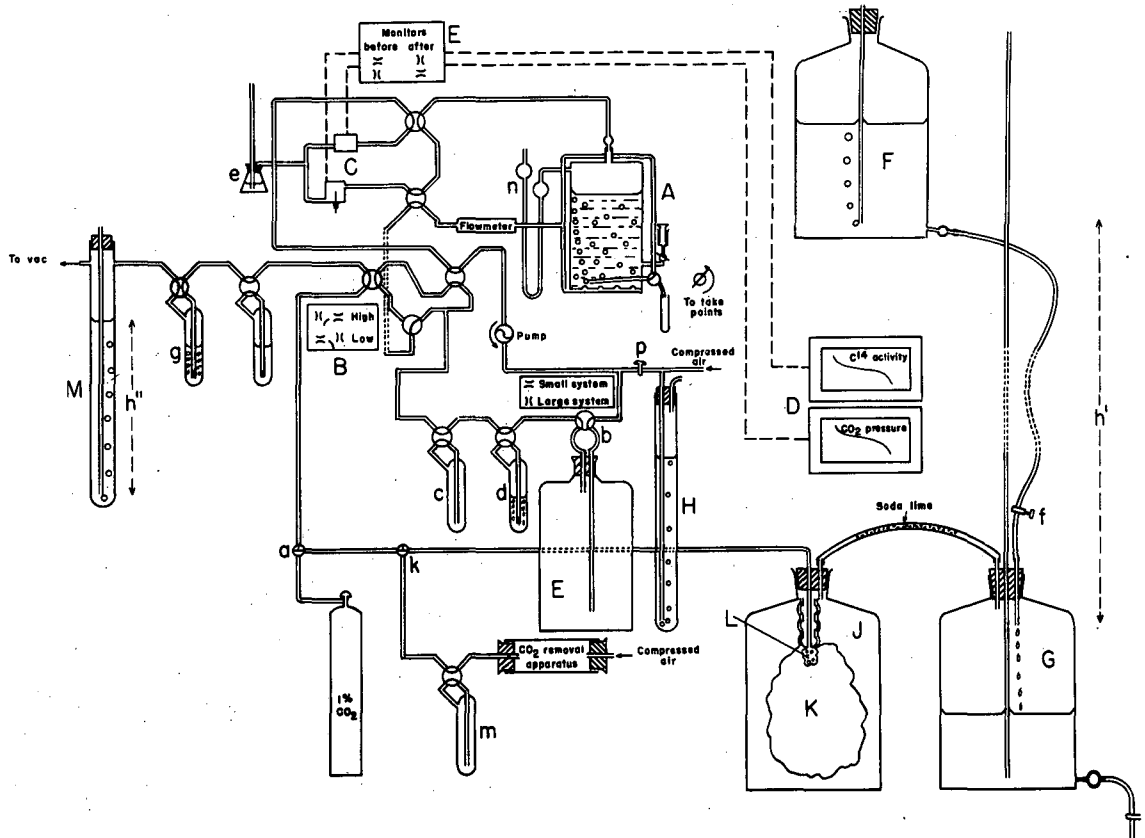

MU-7276

Fig. 2. Diagram of apparatus for measuring transient phenomena and changes in steady state.

for high partial pressures of CO_2 ; one is a non-recycling system for C^{12}O_2 from a gas tank, and the third is a non-recycling system for C^{14}O_2 . It is possible to switch between the recycling system and either of the non-recycling systems by turning three stopcocks on a control panel "B", and also to switch between the non-recycling systems by turning stopcock "a". The gas is continuously monitored for CO_2 partial pressure and radioactivity by an infrared gas analyzer and an ionization chamber respectively, "C". The data is recorded continuously and automatically on chart recorders "D". The monitors may be placed "before" or "after" the illumination vessel by turning two stopcocks on a control panel "E". When the "high" recycling system is in operation the gas passes through a large reservoir "E" (5 liters). This reservoir can be bypassed by turning stopcock "b", leaving only a very small volume recycling. Under these conditions the rate of photosynthesis or respiration can be read directly from the recorders. This feature is invaluable for obtaining the necessary data for designing experiments where certain optimum conditions are required. If, for example, we wish to determine the gas flow which would give us saturation geometry (i.e. when the rate of diffusion of CO_2 across the gas liquid interface is not rate determining) we merely turn down the gas flow until a change of slope is noted on the recorder. In exactly the same manner we may reduce the light in order to determine the point where the system becomes light dependent.

If we allow the system to use up all of its CO_2 , we obtain a curve whose ordinate is the CO_2 pressure and whose slope is the rate of photosynthesis. From these data a plot of photosynthesis versus CO_2

pressure can be readily obtained. The effect of such variables as temperature and pH may be quickly determined under actual operating conditions, and the rate of respiration may be compared to that of photosynthesis by merely turning the lights off and on with the large reservoir bypassed. Trap "c" is used to introduce the $C^{14}O_2$ into the system, and trap "d" is a bubbler which is used to remove the $C^{14}O_2$ at the end of a run. Barometer "e" is a safety valve on the monitor and is calibrated so that the recorder reading can be corrected for pressure effects. Since the monitors measure the number of molecules in a given space, a Boyle's law correction has to be applied. In actual practice the apparatus is designed to have the monitors very close to atmospheric pressure.

The technique of gas handling presents a number of difficult problems, many of which have been overcome in the course of this work. Because of the wide application in other fields, the methods used will be described in detail. The lucite illumination vessel will not withstand large positive or negative pressures, and thus to obtain the gas flow necessary to change from 1% CO_2 to 0.003% in a few seconds, a positive pressure had to be applied to one side of the illumination vessel and a negative pressure to the other, leaving a net pressure inside the illumination vessel of a few mm. Hg above atmospheric pressure. The actual pressure in the illumination vessel is measured directly by a water manometer "n" which also acts as a safety valve to protect the vessel from damage should large positive or negative pressures build up. The positive pressure was supplied by a constant head "h" of about

14 feet of water. Water flowed from "F" into "G" where it displaced air into vessel "J". This caused a balloon "K" which contained the radioactive $C^{14}O_2$ to close, thus this gas was forced through the illumination vessel and out through a trap "g" where the $C^{14}O_2$ was removed. The required constant negative pressure was supplied by device "M". The constant head device in "F" and "G" enabled one setting of the screw clamp "f" to maintain the flow constant throughout a run. The balloon is filled through stopcock "k". The tube from "F" to "G" is clamped off and water is run out of "G" pulling air from "J" into "G" which pulls the balloon open sucking CO_2 -free air into "K". The $C^{14}O_2$ is added via trap "m". Since 0.003% CO_2 was being handled, and since it was important that its specific activity be maintained, a soda lime absorber was placed between "G" and "J". This absorber was considered necessary in the light of the solubility of CO_2 in rubber. At first much trouble was encountered with the balloon bursting while it was being evacuated, but this problem was solved by means of device "L" which is a small perforated glass bulb through which the gases are removed from the balloon. The many holes and irregular shape of this glass bulb prevent the outlet from being blocked by the collapsed balloon before the balloon is completely empty. If large quantities of liquid are withdrawn from the illumination vessel while on the closed system, the pressure drops to such an extent that no more liquid can flow out. This drop in pressure is avoided by having a device "H" which maintains the high side of the pump at a fixed pressure above atmospheric. This device can be eliminated from the system by stopcock "p".

Illumination Vessel. - The design of the illumination vessel "A" is a radical improvement over the more conventional "lollipop"-type vessel. The redesigning has been done to make possible more close control of the external conditions and to enable the apparatus to be adaptable to a wide variety of experiments including the study of transient phenomena. The vessel is of laminated construction (Figure 3) and is made of sheets of lucite held together with bolts through a duraluminum frame. The seals between the lucite lamination were made of neoprene gaskets. The construction enables easy dismantling for cleaning. By the simple replacement of the center lamination, the vessel can be used for a wide variety of experiments (eg. a glass electrode could be inserted). The outer laminations constitute a water jacket through which water is circulated from a thermostat by means of a centrifugal pump. Figure 4 shows the center lamination. The newer features include a sampling device "Z" whereby samples of the order of 1 ml. of a 1% suspension may be withdrawn quickly without contamination with algae not representative of the suspension. As the stopcock is turned in an anti-clockwise direction (Figure 4) the sample is successively (1) run out into a sample tube, (2) the outlet tube blown out, and (3) the internal tube blown out ready for the next point. With such a device, samples can be taken every 4 seconds for extended periods of time. A syringe "Y" is mounted on the side of the vessel to inject liquid into the suspension. In the study of pool sizes versus CO₂ pressure, this device was used to inject C¹⁴O₂-saturated water. In future experiments this feature could be used to change the pH of the suspension or to study the effect of a variety of poisons. If desired, it can be eliminated from the system by turning stopcock "Y".

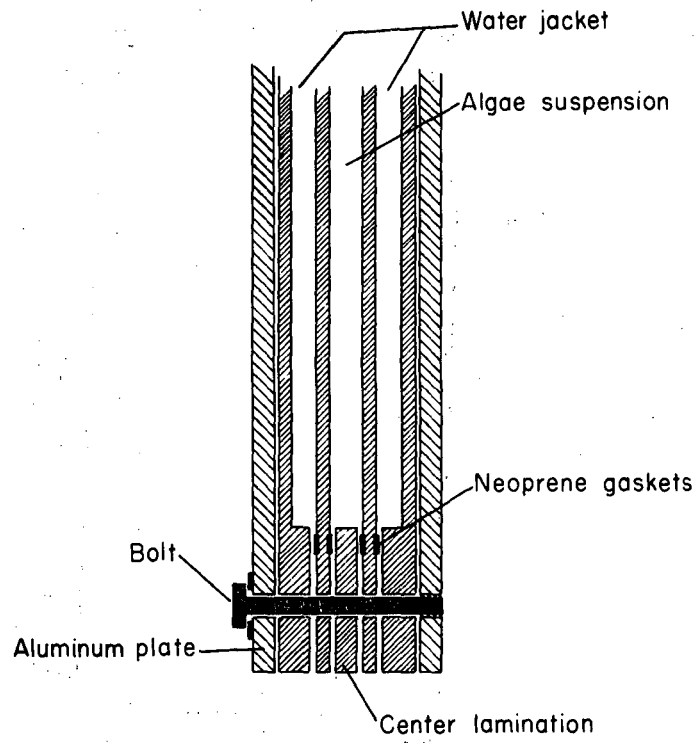

CROSS SECTION OF LAMINATED ILLUMINATION VESSEL

MU-7409

Fig. 3.

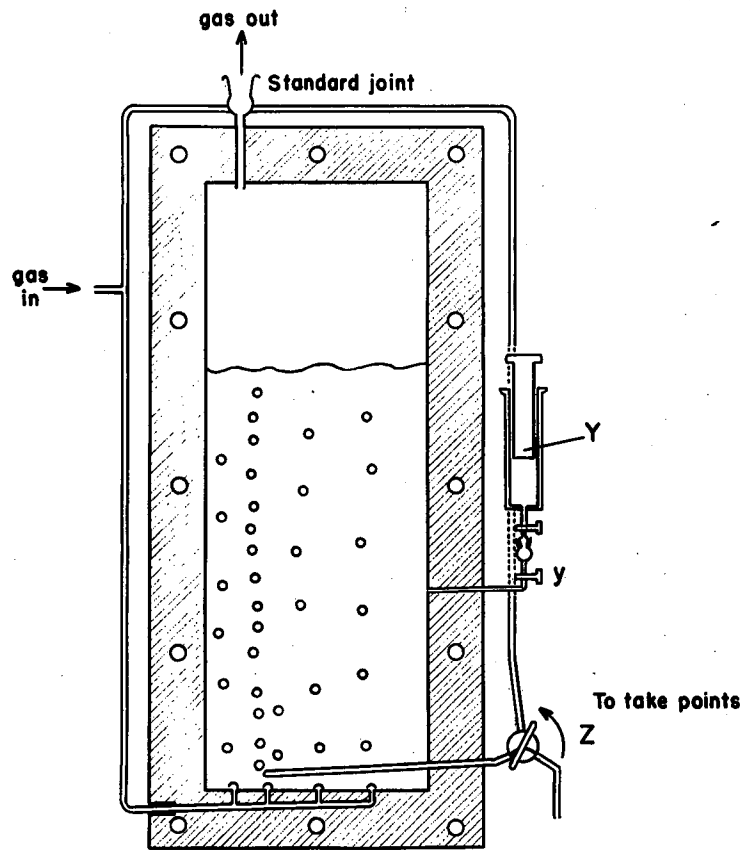

CENTER LAMINATION OF ILLUMINATION VESSEL

MU-7410

Fig. 4.

General considerations. - Temperature of illumination vessel:

It is usually advisable to have the illumination vessel below room temperature in order to keep the gas in the system below saturation and to avoid condensation in other parts of the apparatus.

Effect of solubility of CO₂ in rubber: The solubility of CO₂ in rubber is much greater than is generally realized. For example, if 1% CO₂ in air is cycled through a length of rubber tubing with a CO₂ analyzer in the circuit, the concentration of the gas falls quite rapidly towards 0.09%. If after a time the gas is replaced by air (0.09% CO₂), the CO₂ comes out of the rubber and the concentration of CO₂ increases. Tygon exhibits this phenomenon to a lesser degree (about 50%). To overcome this difficulty the apparatus was constructed of glass wherever possible and where it was necessary to make a non-rigid connection, the glass was butted together under a tygon seal so that as little tygon surface as possible was exposed.

CO₂ infrared gas analyzer. - The CO₂ gas analyzer used is a Liston-Becker Model 15 instrument.* Its operation depends on the fact that CO₂ has a very strong infrared absorption band between 4.2 and 4.3 μ . Its method of CO₂ detection is simple yet extremely ingenious. Glow bars produce infrared radiation which is passed down two tubes, one of which is a dummy, the other containing the sample. The radiation then passes into the detector assembly which consists simply of two chambers, both filled with pure CO₂, separated by a diaphragm. The

(*) Liston-Becker Instrument Co., Inc., Stamford, Connecticut.

detector is only sensitive to the CO₂ absorption bands which absorb heat and cause the gas to expand, displacing the diaphragm. The diaphragm constitutes one side of a condenser which is coupled in a resonant circuit with an inductance. The inductance is tuned so that it is a little off resonance and on the linear part of the resonance curve. Any bands other than those absorbed by CO₂ pass through the detector and are dissipated in the walls without heating the gas. Thus the detector is insensitive to water vapor and other substances absorbing in the infrared region provided the detector gas is pure. Radio frequency voltages are applied across the condenser so that a very small motion of the diaphragm will produce a useable signal which is amplified and employed to drive a recorder. In order to eliminate zero drift due to ambient temperature changes, the radiation is modulated by a 10 cycle chopper. A small hole is placed in the diaphragm so that slow pressure changes will equalize across the diaphragm while sudden 10 cycle pressure variations will serve to actuate the diaphragm. The sensitivity to the 10 cycle modulation is further insured by rectifying the amplified signals synchronously with the light chopper. The instrument is produced mainly for industrial application and will deliver up to 5 ma into resistances up to 500 ohms. Thus it will produce 0.125 watts at full power. The instrument is manufactured in this manner so that it can be used to drive a current recorder directly. The gain settings on the instrument are really gain settings on the amplifier and therefore have the disadvantage of making the zero dependent on the gain setting. Since we were

equipped with high impedance recording potentiometers it was felt that it would be advantageous to leave the amplifier controls turned down and instead of putting the output of the analyzer across a 2 ohm resistance, as is suggested in the instructions, to put it across a 25 ohm variable resistance. Thus a variable span would be provided which would not affect the zero setting. We have, in effect, taken the calibration curve AB and blown it up 12 1/2 times so that the section AC now covers our range.

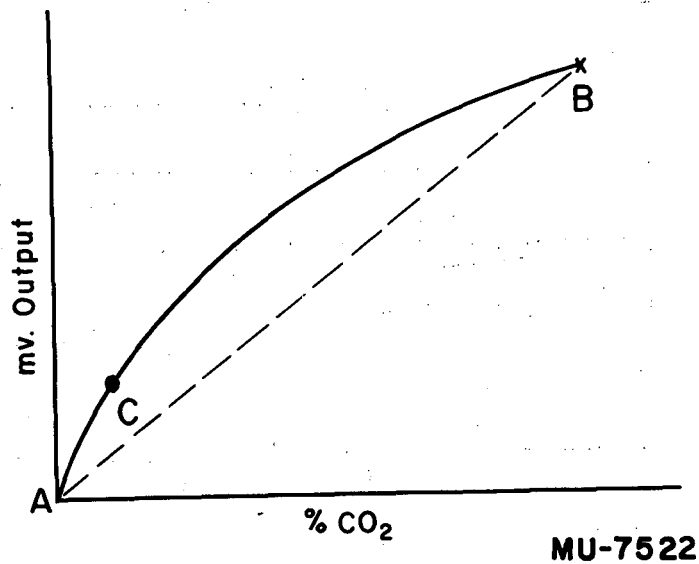

If we were to increase the resistance across the output of the analyzer 20 times (i.e. up to the permitted 500 ohms) we could obtain another factor of 20 in the sensitivity. The cells supplied with the instrument give maximum sensitivity although the output is not completely linear with CO₂ pressure. Since we have plenty of sensitivity to spare, it is often more convenient to sacrifice some of the sensitivity to get a more linear output. This can be done by using as thin a cell as possible and boosting the gain by increasing the resistance across the output.

Extraction of phosphates from algae

It was observed, during the investigation of extraction of phosphorylated compounds from algae, that the 80% alcohol extract contained most of the photosynthetic intermediates except ribulose diphosphate. If the resultant residue were extracted with 20% alcohol, most of the activity was found to be ribulose diphosphate with a trace of PGA. This procedure would find useful application in the isolation of ribulose diphosphate from algae.

Absorption of phosphorylated compounds on plant materials

In order to quantitatively extract the phosphorylated compounds from the dead algae, the algae have to be extracted completely with 80% EtOH and then at least twice with 20% EtOH. Under these conditions there is also extracted a material which, although soluble in ethanol solutions, is insoluble in water and is precipitated when samples are evaporated down prior to placing on paper. As the solution is further concentrated, this material adsorbs phosphorylated compounds, particularly the ribulose

diphosphate and to a lesser extent PGA and the other phosphorylated compounds (as can be shown on phosphatasing when it yields principally ribulose). When the mixture is placed on paper the phosphates are not eluted from this material but remain on the origin. The difficulty can be overcome by centrifuging this material from the solution before it becomes too concentrated (at 1-2 mg. cell extract per 1 ml. solution). At this concentration the material carries down no phosphorylated compounds, as can be shown by redissolving in alcohol and rechromatographing. The best way to effect this separation is to freeze the sample slowly in the deep freeze and to let it thaw out in the centrifugal field. It is probably the above phenomena that accounts for the lack of ribulose diphosphate on chromatograms of soy bean experiments.

The "octopus"

(Figure 5) The further the project proceeded the greater became the need for more experimental points in order to get the shape of the curves more accurately. This need was particularly apparent in transient phenomena in which we were particularly interested. Larger and more elaborate experiments were required, usually involving more than 100 points, all of which had to be worked up individually, and it soon became clear that a simple, direct and preferably automatic method was required for the processing of the multitude of samples. An apparatus called an "octopus" was designed and constructed which would evaporate a sample represented by perhaps 15 ml. of solution, to a small volume (ca. 50 λ) maintaining the temperature always below that of the room. These samples could then be transferred directly to the origin of a chromatogram.

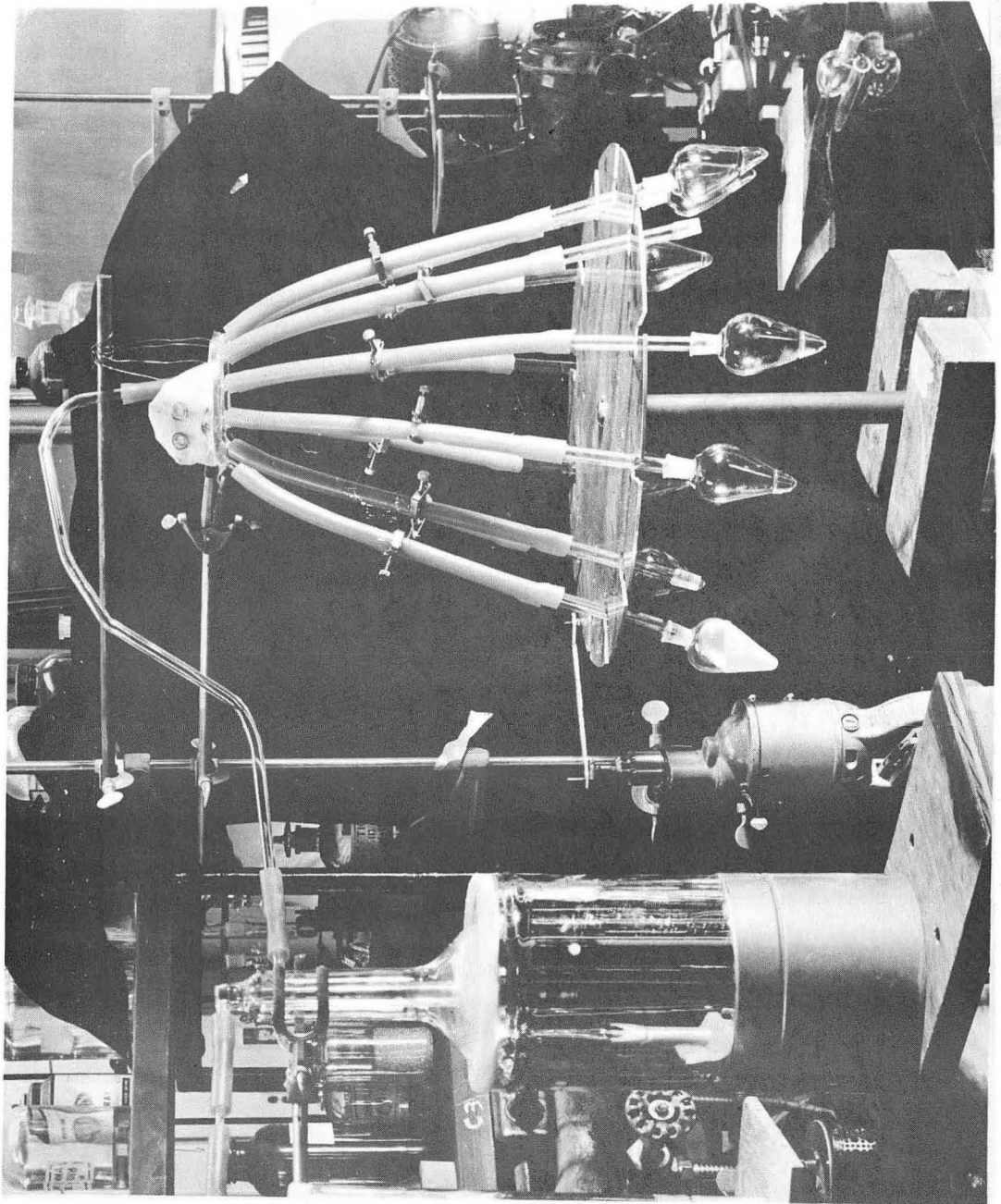

ZN-958

Fig. 5. Photograph of the "octopus".

Twelve samples could be evaporated simultaneously and as a result the rate-determining factor of the whole process lay in the transfer of the samples. The apparatus (Figure 5) consisted of a manifold with twelve arms; at the end of each of these could be placed a flask containing the sample. These flasks were kept in motion (to prevent surface freezing or bumping) by an aluminum plate 12 inches in diameter with holes in it for the flasks. The aluminum plate was itself kept agitated by a 1/4 inch electric drill. The whole system was evacuated by a rotary oil pump, and a large dry-ice ethanol trap was used to collect the distillate, the pump being protected by a liquid nitrogen trap. This apparatus already has saved hundreds of man hours of tedious work and will have valuable application in any future work in this field.

Chromatography

Introduction

Before a quantitative analysis could be made of the photosynthetic intermediates obtained in controlled experiments, they had to be separated. The only really suitable method of doing this is by means of chromatography. Thus, the quality of the work depended to a large extent on the quality of the chromatograms. This was true even in the qualitative experiments, and progress was determined to a large extent by progress in chromatographic techniques. However, for quantitative work, separations had to be complete and reproducible. The early intermediates of particular interest to us in photosynthesis are, without exception, phosphorylated. The chromatography of phosphorylated compounds^{24,25,26} is a much more difficult problem than the chromatography of amino acids, acids, or free sugars, and the problem of quantitative chromatography even more difficult. Thus it is clear that an appreciable portion of the effort put into a project of this kind should go into research into the techniques of chromatography.

Chromatographic techniques

Solvents. - The first solvent used is a neutral one, usually phenol/water^{**} which performs a good primary separation of the compound on the basis of type, the free sugars being moved away from the phosphorylated sugars with which they would interfere in the second solvent. The second solvent usually used was butanol/propionic acid/water,^{***} which

(**) Phenol (redistilled) 100 g.; water (deionized) 39 g.

(***) Reagent A: Butanol 3750 ml., water 253 ml. Reagent B: Propionic acid 1760 ml., water 2240 ml. Solvent equal parts of A and B.

carried out the secondary separation. The order of the solvents is important since it is impossible to remove completely all traces of acid from the paper by drying. If phenol were the second solvent it would not be neutral, but a second acid solvent. There seem to be two types of acid solvents, the weak organic acids like propionic and acetic, and the strong acids such as trichloroacetic and picric.**** The various weak organic acid-alcohol solvents all give much the same results. However, strong acids, consistent within themselves, give a very different kind of chromatogram. The PGA, P-glycolic and P-pyruvic acids are well separated, as are the hexose monophosphates. Examples of such chromatograms are given in Figures 6, 7 and 8; the R_f values in picric acid, relative to orthophosphate, are given in Table I. The disadvantage in the use of a strongly acid solvent like picric (or trichloroacetic)/t-butanol is that it leads to the decomposition of the UDFG spot³⁵ causing the free glucose to run into the hexose monophosphate region. This difficulty can be overcome by making the algal extract alkaline. (NH_4OH is the most convenient). The UDFG is thus decomposed, and on running it appears as two spots which were identified as glucose and galactose cyclic phosphates (see appendix). These compounds have the same R_f value as glucose monophosphate in the acid direction but have about twice the R_f value in the phenol direction.

Effect of phenol in acid solvent: There is still much work to be done on the technique of chromatography. If, for example, phenol

(****) Tert-butanol-picric acid solvent was that of Hanes and Isherwood²⁴ as modified by Mitchell and Moyle.²⁷

Fig. 6. Example of a phenol-picric chromatogram of an ammonia-treated extract of Scenedesmus.

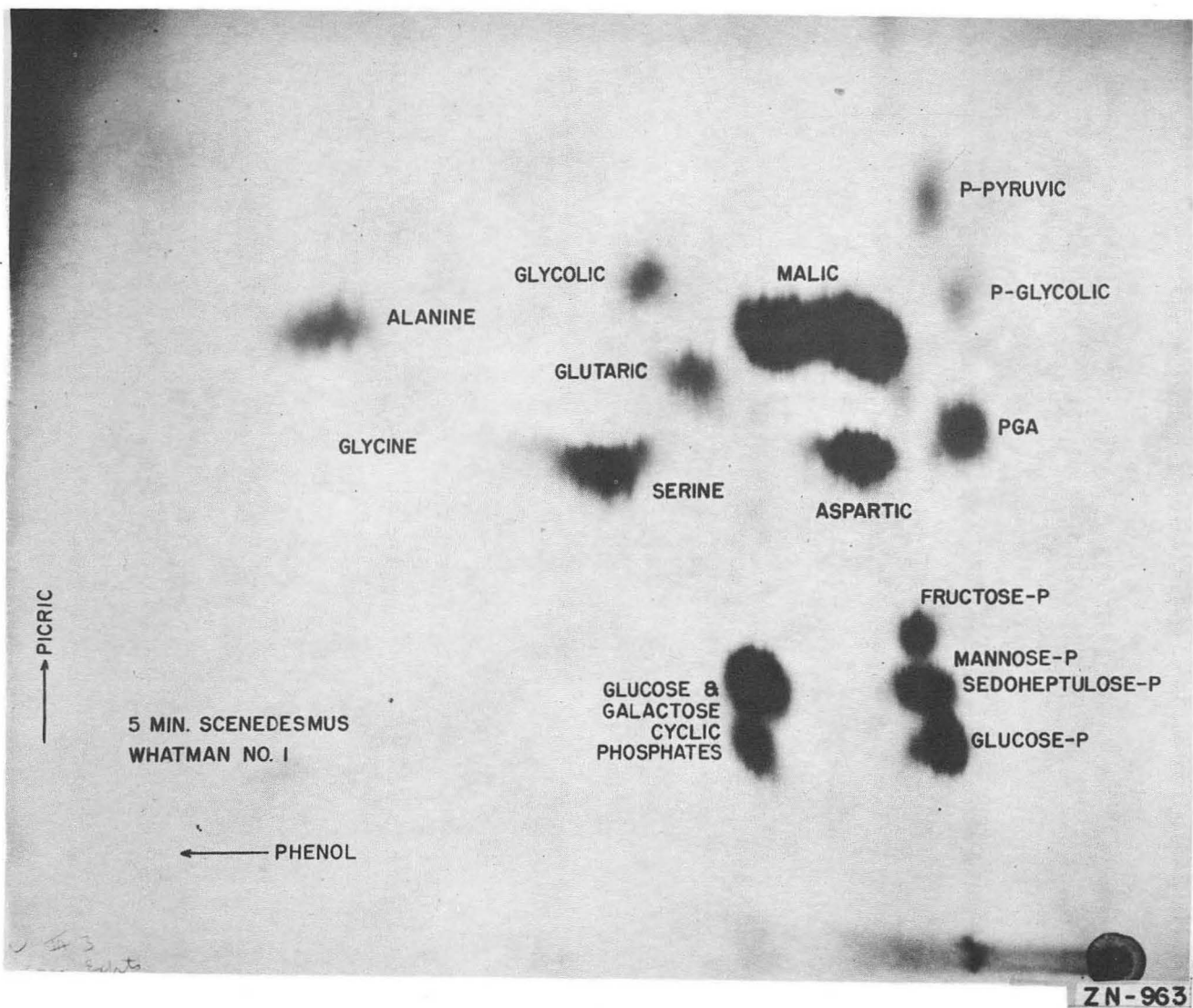

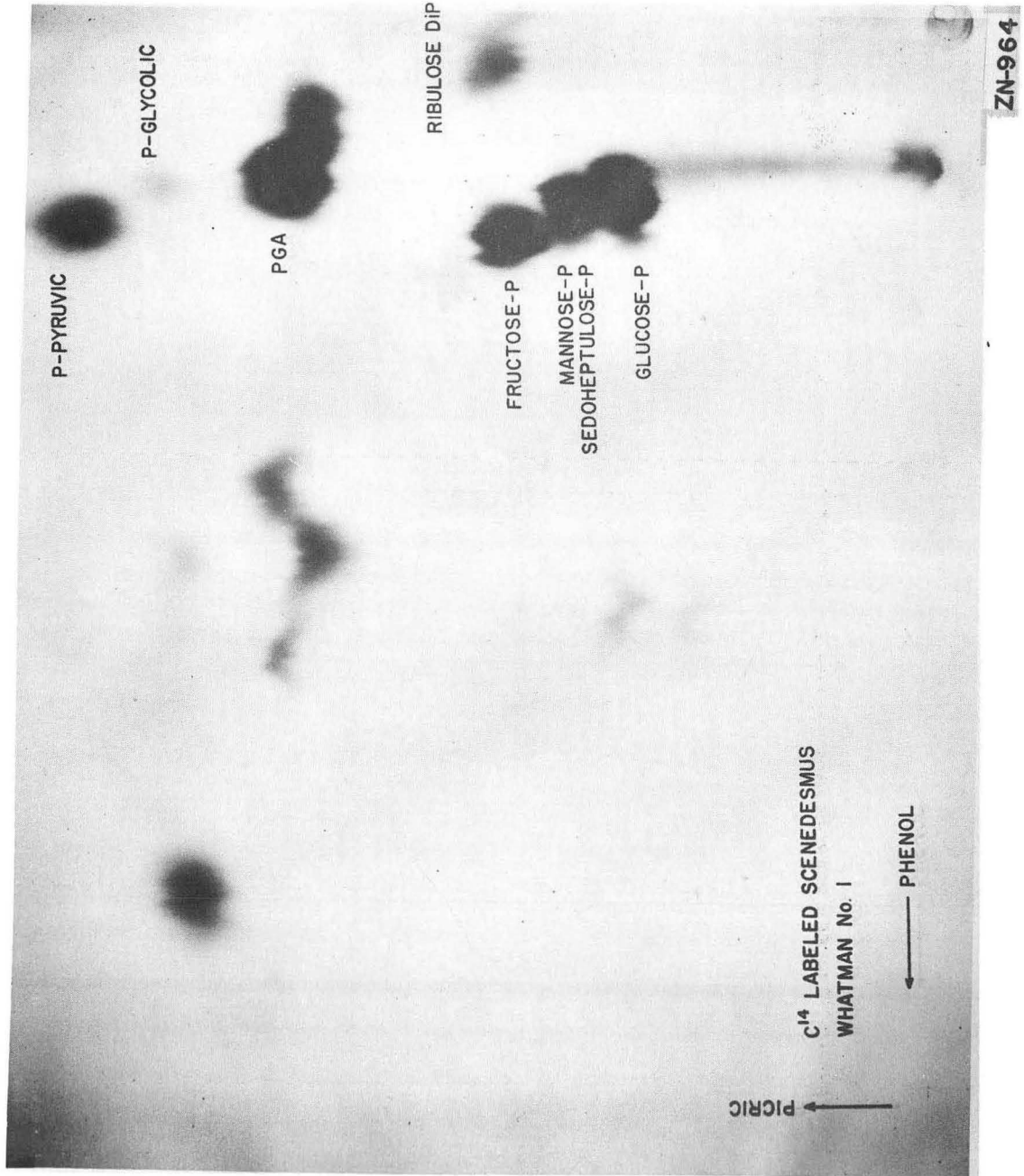

Fig. 7. Example of a phenol/picric chromatogram of an untreated extract of Scenedesmus exposed to C¹⁴O₂ for one minute.

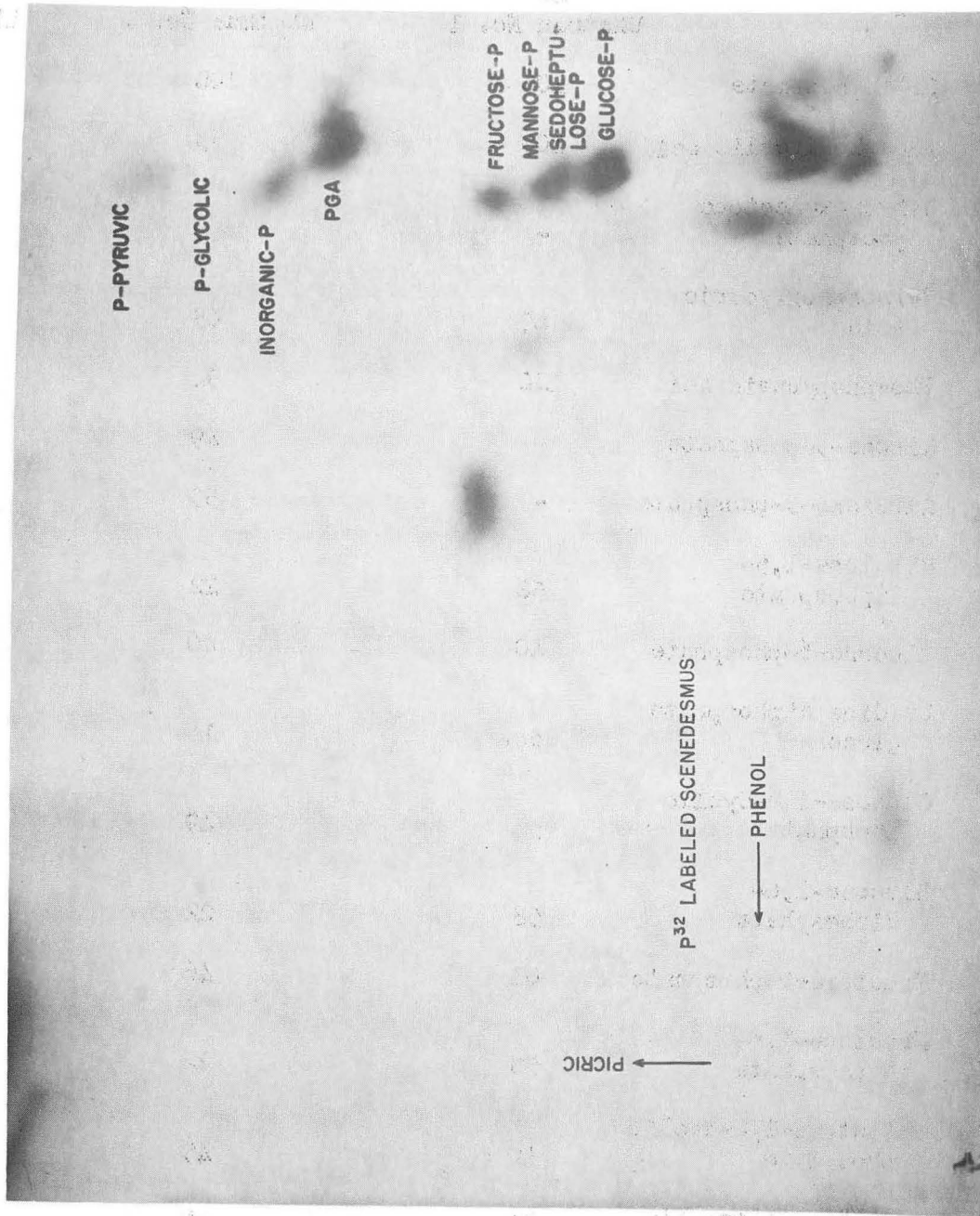

Fig. 8. Phenol/picric chromatogram of P³² labeled Scenedesmus.

Table I

	t-butanol 80 g. picric acid 2 g. water 20 g. 22° Whatman No. 1	butanol 100 g. propionic acid 50 g. water 70 g. 22° Whatman No. 1	phenol 72 g. water 28 g. preequilibrated 22° Whatman No. 4
Orthophosphate	100	100	100
Phosphoglycolic acid	106	75	102
Dihydroxyacetone phosphate	-	59	170
3-Phosphoglyceric acid	89	65	100
Phosphopyruvic acid	120	92	26
Ribose-5-phosphate	-	49	139
Ribulose-5-phosphate	-	53	147
Ribulose-1,5- diphosphate	58	22	26
Glucose-6-phosphate	40	40	113
Uridine diphosphate glucose	dec.	15	111
Glucose-1,2-cyclic phosphate	54	49	170
Glucose-1,6- diphosphate	58	22	26
Fructose-6-phosphate	61	46	125
Fructose-1,6- diphosphate	58	22	26
Galactose-1,2-cyclic phosphate	40	49	170
Mannose-6-phosphate	52	46	125
Sedoheptulose-7- phosphate	52	40	113

papers are not properly dried before running in the acid solvents, the compounds have very low R_f values and are small and very sharp. This fact, as such, is of no practical value, but if the reason for the small sharp spots could be found and incorporated into the techniques used, it would lead to a great improvement in the chromatograms. The reason is probably linked with the solvent phase separation, discussed in the later section on double spots (i.e. effect of phenol on three-component phase system of the solvent).

Paper. - Types of paper: The classical paper used in chromatography has been Whatman No. 1. Various other papers were tried and it was found that Whatman No. 4 was far superior for phosphorylated compounds (Figure 9). The solvents ran almost twice as fast on this paper as they did on Whatman No. 1 and much better separation of compounds resulted. The hexose monophosphate region was reproducibly split into two spots, glucose and sedoheptulose monophosphate, and fructose monophosphate. Perhaps the greatest advantage of Whatman No. 4 paper was the lack of origin sticking, probably related to the different properties of the cellulose fibers making up the paper.

Washing papers: Although amino acids and free sugars give perfectly satisfactory results on untreated paper, it is virtually impossible to obtain good results with phosphorylated compounds. This is due to the presence on the paper of Ca^{++} and other heavy metals which can be removed by washing the paper with 1/2% oxalic²² or acetic acid.²⁴ Although the papers are subsequently washed thoroughly with distilled water they give an acid reaction to indicator. This is true even after they have

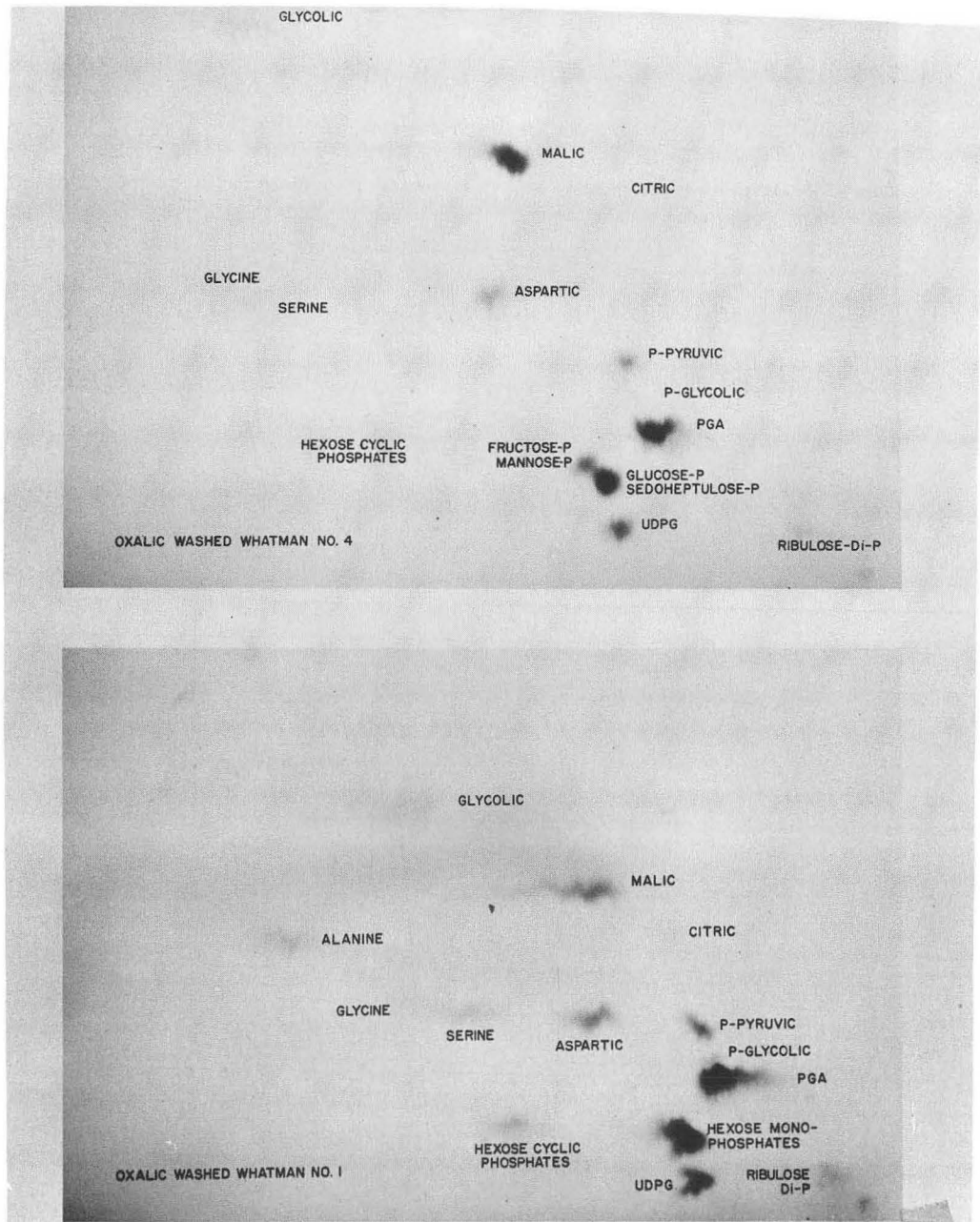

Fig. 9. Comparison of Whatman No. 1 and Whatman No. 4, both preequilibrated and run under identical conditions with the same algae extract (one minute photosynthesis Scenedesmus 80% ethanol extract).

been treated with ammonia and dried. Thus oxalic-washed papers are not only metal free but also quite acid. To determine the effect of the acid, paper was washed with 1/2% EDTA solution at pH 7, resulting in a neutral paper free of heavy metals. This type of paper gave a chromatogram (Figure 10) on which the spots had run with higher R_f values but were large and diffuse. It seems that the acidity of the paper has the advantage in holding the compounds together in sharp well-defined spots (cf. Figures 9 and 10).

Preequilibration of papers: Various experimental conditions for the running of paper chromatograms were investigated and it was found that the preequilibration of the paper and subsequent chromatography in a water-saturated atmosphere led to a markedly different result than when the papers were run in unsaturated boxes or saturated only with respect to solvent. For preequilibration, the papers were hung in the box with water in the bottom for at least 4 hours before the solvent was added to the troughs. This treatment has profound effects on the R_f values of the compounds. In the case where phenol is used as the solvent the compounds move with higher R_f values and the overall separation is much improved (Figure 11). The adsorption, or shadowing behind the phosphorylated compounds is also completely eliminated. This probably accounts for much of the previously observed variation in the quality of chromatograms over a period of time even when run by the same worker supposedly using the same conditions, since variations of humidity would have a profound effect on the quality of the chromatogram. In the case where butanol-propionic acid is the solvent, preequilibration is detrimental to the quality of

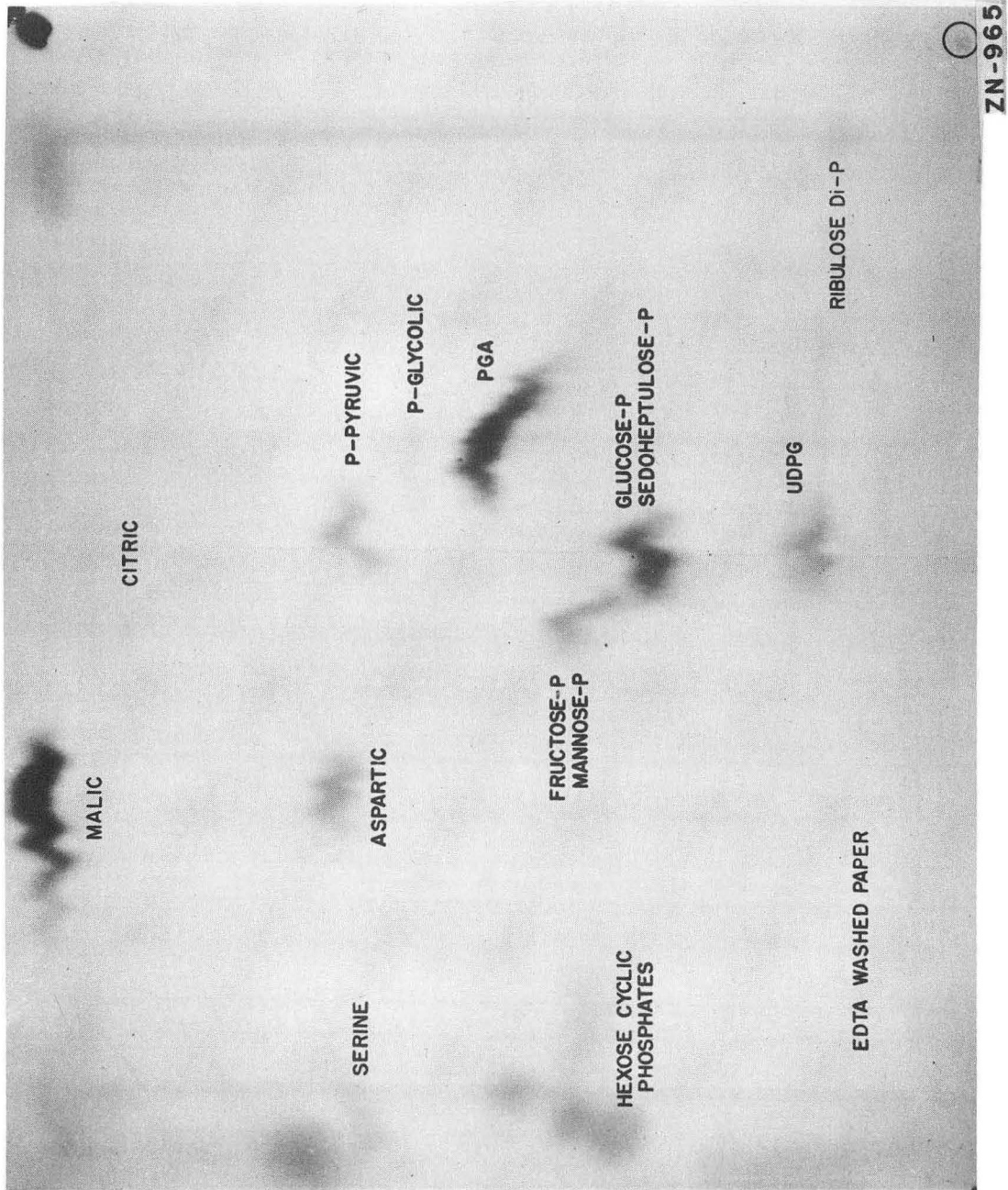

Fig. 10. One-minute photosynthesis by Scenedesmus, 80% extract pool run on EDTA washed paper.

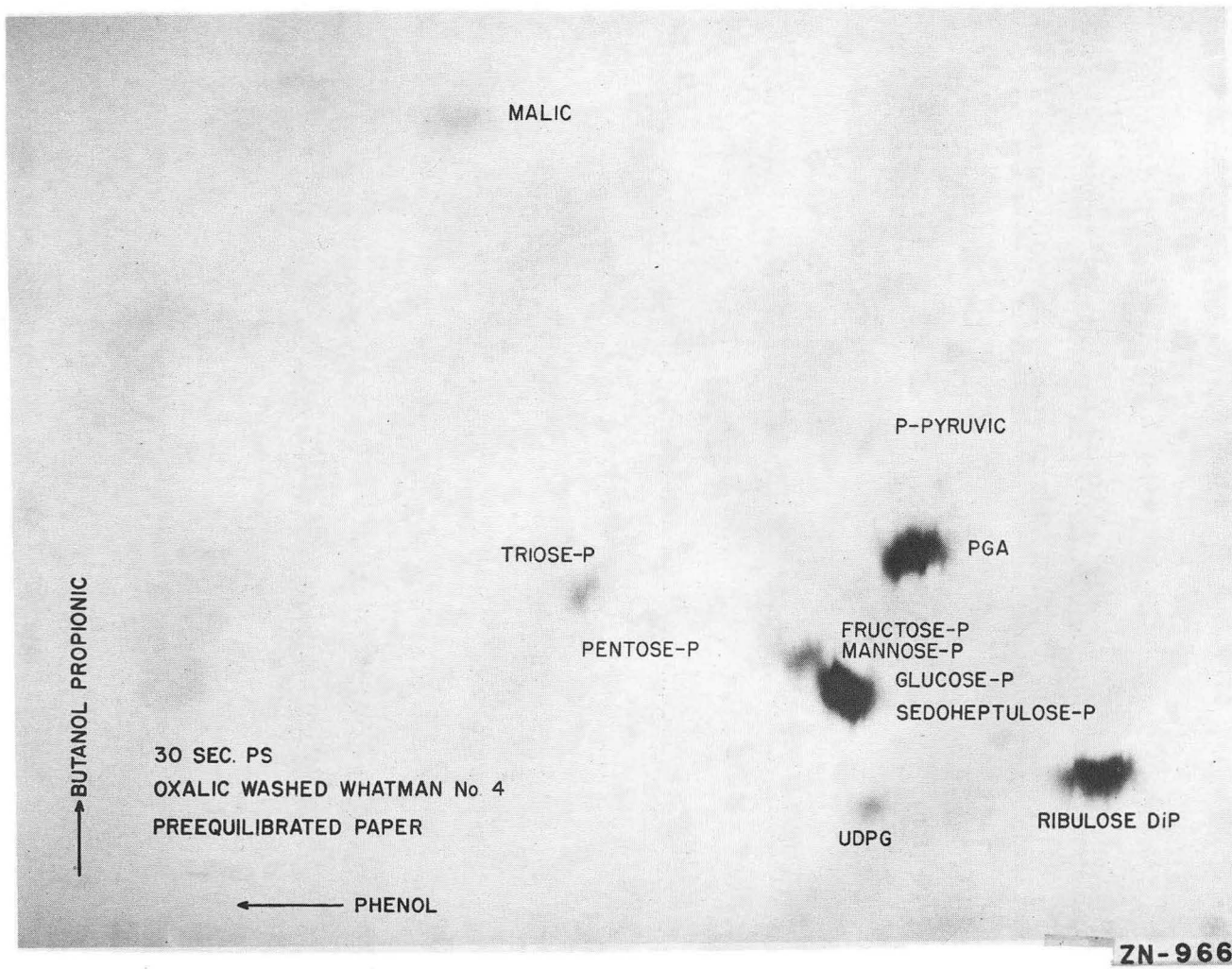

Fig. 11.

the chromatogram, and the compounds move with higher R_f values but tend to bunch up so that the separation is poor. A water-free box is therefore desirable when butanol-propionic acid is used as solvent. When picric/t-butanol is used as solvent, preequilibration is disastrous with all the compounds running on the front.

The use of thick paper: Thick papers, such as Schleicher and Schuell 470-A and the paper which is used as raw material for the Viscose process, ***** were used for chromatography. Such papers have application in the preparation of large amounts of material and are quite practical for phosphates provided the paper is acid-washed. The spots are larger, however, and the separations not as good.

Quantitative techniques in chromatography

Basic assumption. - The method of measuring the size of reservoirs by counting radioactivity in the spots was based on an experiment where the count was determined as a function of the amount of carrier. It is conceivable that larger amounts of carrier might produce larger spots which might in turn lead to a lower count due to increased self-adsorption, but this was not the case as was demonstrated by the experiment described below:

A mixture of C^{14} -labeled malic acid and sucrose was taken and the same aliquot of this solution mixed with various amounts of malic acid carrier. These final solutions were put on paper and run in the conventional way. The ratio of sucrose count to malic acid count was independent of the amount of carrier malic to within 5% over the range of 0 to 100 γ carrier malic added per paper.

(*****) We are indebted to Dr. B. Axelrod for supplying samples of this material.

Direct paper counting of spots. - The elution onto a metal plate of every spot to be counted would involve a prohibitive amount of time. It is possible to count the spots directly on the paper with 1/3 efficiency, if certain precautions are observed in the drying of the chromatograms after they have been run in the solvents. They should be dried at least 6 inches apart, and if such is the case, no trouble is encountered by spots giving more counts on one side of the paper than on the other side.

Origin sticking. - The greatest obstacle to quantitative chromatography of phosphorylated compounds was origin sticking, for which the phosphates are particularly noted. Experiments showed that petroleum-ether extraction of the samples reduced the origin sticking. This treatment did not remove any compounds other than those which ran on the front in both solvents. Wetting the paper with water reduced considerably the amount of origin sticking, especially in dry weather. This is probably one reason for the variation in the amount of origin sticking at different times, even though apparently the same procedure is followed (i.e. the humidity can affect the amount of origin sticking). The best way to avoid the origin sticking of phosphorylated compounds when Whatman No. 1 paper is used is to place the papers in a high humidity atmosphere for several hours, and then to evaporate the compounds on to the origin while the papers are still in an atmosphere of high relative humidity. For this purpose a special box was constructed; later developments, however (see below), rendered this technique obsolete.

The greatest amount of irreversible adsorption was obtained when a hot dry stream of air was used to evaporate the sample onto the paper and the paper allowed to dry out between additions of material. Such a procedure dehydrates the paper, especially around the edges of the origin, and results in a series of super-imposed rings of irreversible adsorption. The greatest improvement comes in the use of Whatman No. 4 paper. If this paper is dampened and the origin put on with a high-speed blower using no heat, the problem of origin sticking is completely solved.

New technique for secondary separation of phosphorylated compounds. - In the earlier qualitative experiments the spots containing the mixed phosphorylated compounds (as for example the hexose monophosphate area) were cut from the paper and eluted into small test tubes. Phosphatase solution was then added to the tube and the mixture allowed to stand under toluene for several days. The resultant solution was then evaporated onto the origin of a second chromatogram with a pipette. This procedure suffered from two disadvantages: first, any attempt at a quantitative procedure resulted in a very long and tedious process which took about 20-30 man minutes per spot; and second, phosphorylated compounds, especially ribulose diphosphate, are adsorbed onto the paper and are not readily eluted quantitatively. The procedure developed was to spray phosphatase solution (0.1-0.2%) directly onto the spot until it

became translucent.***** This paper was then hung in an atmosphere saturated with water vapor and toluene for a few days, and the spot was eluted directly and automatically onto the new paper with a device which is shown in Figure 12. This device was readily adaptable to mass production as shown in Figure 13. The unit (Figure 12) consisted of two glass plates with matching holes 2 inches in diameter. The top plate supported a glass trough containing water, and a strip of filter paper was dipped into and hung over the edge of this trough. The spot to be eluted was attached to this strip of filter paper by capillary attraction. A drop of "Scrip" washable black ink was placed on the top edge of the spot to give an indication of when the compounds were completely eluted. The ink used consists of three dyes, blue, yellow and red. Tests showed that all the free sugars came off well before the red dye. These dyes served the further useful purpose of acting as a series of markers on the final chromatogram. A sheet of Whatman No. 1 is placed between the glass plates in such a way that the origin lies between the two matched holes, while the spot is arranged so that its tip just touches the paper in about the center of the hole. A stream of air from a high-speed blower directed at the lower side of the origin serves to evaporate the water which has eluted the spot. With this technique it is possible to obtain very small origins. The inherent advantage of such a method is that free sugars and not phosphorylated compounds

(*****) The application of the phosphatase solution with a pipette is not satisfactory since the enzyme stays at the point of contact of the pipette with the paper (it is absorbed on the cellulose and is not carried throughout the paper by the water). Since diffusion is a relatively slow process, it is advisable to have the enzyme sprayed onto the paper so that it is distributed evenly over the surface.

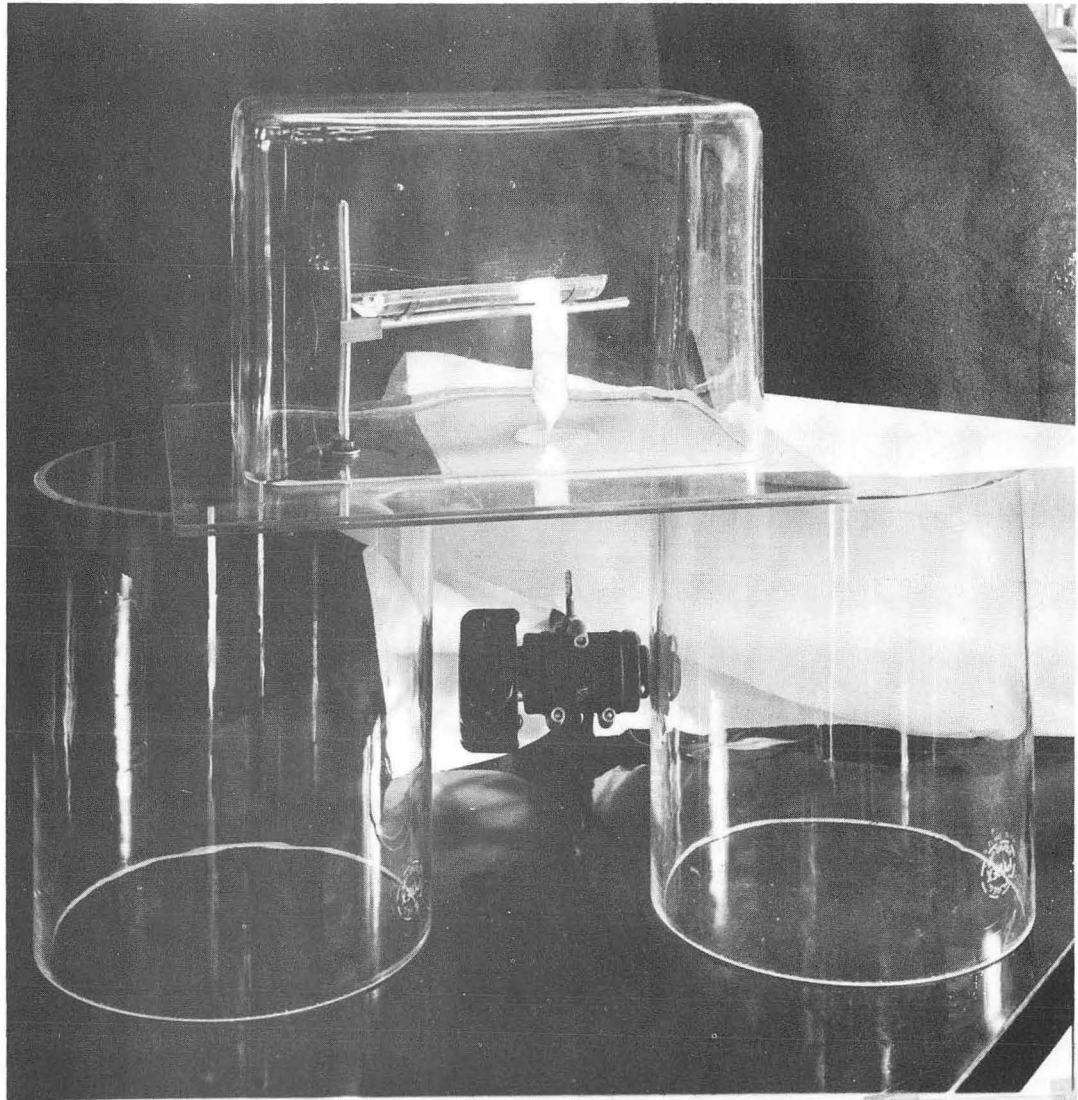

ZN-960

Fig. 12. Elution Apparatus.

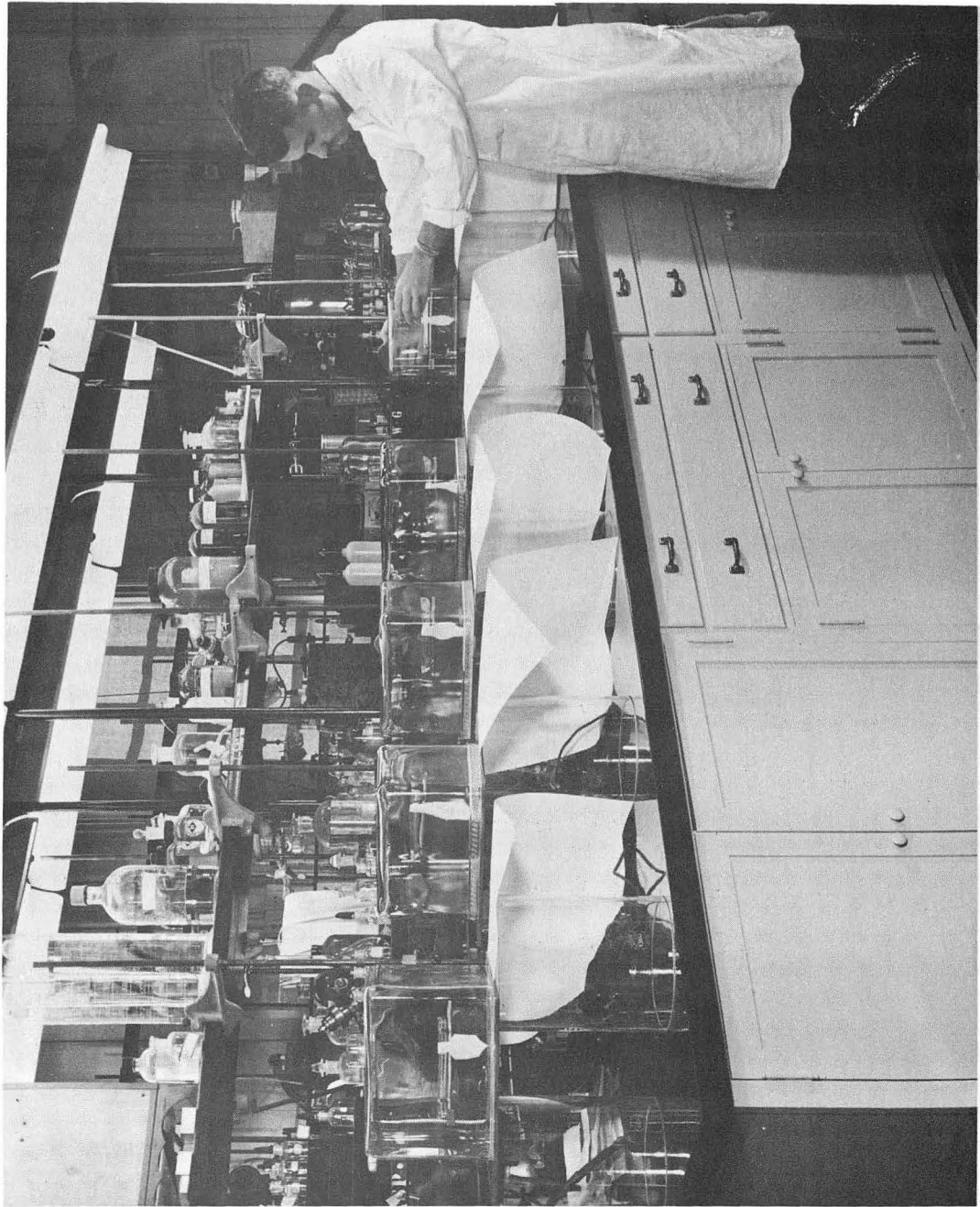

Fig. 13. Large-scale elution of spots.

are eluted. A further advantage is that a quantitative result is obtained in about 30 man seconds as against 20 man minutes by the older more conventional method.

Chromatographic theory

Double spots. - The theory of paper chromatography is still not completely understood, or rather let us say there are many phenomena met in chromatography which are not explainable by the simple theory. Thus the investigation of such phenomena as double spots has a two-fold purpose, (1) to aid in the interpretation of chromatograms and (2) to further a better understanding of the mechanism of paper chromatography. The phenomena of double spotting has been investigated and double spots are found to fall into the following groups:

(1) The chelate type - Malic and glycolic acid double spots are of this type. The spots appear to be two different chemical substances, one being the free substance and the other a complex with some metal such as Ca^{++} . For obvious reasons this type of double spotting is not encountered when washed paper is used.

(2) The distribution type - Double PGA spots are of this type. It has always been a fundamental concept of chromatography that two spots represent two distinct chemical identities. The split PGA spots are an exception. The conditions for the formation of double spots have been studied and found to be caused by (a) increasing the loading and (b) moving the origin nearer the initial solvent front.

A theory for the formation has been postulated and is given below. Double spotting of the distribution type appears to take place only in

mixed solvents and only with certain compounds. Although it is seldom given much thought, it is quite reasonable that the constituents of a mixed solvent such as butanol/propionic acid could be separable by paper chromatography. It is believed that such a separation does occur and that the butanol runs faster than the mixture. Thus we have a phase separation with alcohol-rich phase running out in front. Now PGA appears to have the property of running faster in the first phase than the interphase front and slower in the second phase than the interphase front. Thus, if PGA ever gets distributed across the interface it will form two spots and they will move apart. The conditions are: (1) When the PGA is near the starting point of the solvent, in which case the band of the first phase is narrower and cannot hold all the PGA and (2) with heavy loading so that the first solvent cannot hold all the PGA. More direct evidence of this phenomenon of phase separation can be had by spraying a chromatogram which has been run in such a solvent as butanol/propionic acid with bromocresol green. Here the phenomenon is graphically illustrated with two sharply defined areas, one blue and the other yellow. Tert-butanol/water/picric acid solvent exhibits the phenomenon in even a more direct manner the yellow phase running some distance behind the colorless solvent front. These results point to the rather obvious but seldom realized fact that mixed solvents can themselves undergo chromatographic separation. Other evidence has been reported by other workers^{28,29} for the existence of frontal analysis by dehydration of the solvent by the paper.

(3) Origin reflection type - This type of double spot is found principally when picric has been used as the second solvent, and no precautions have been taken to avoid origin sticking. The first solvent leaves part of the material on the origin, some of this is removed by the second solvent to give a second spot which has the same R_f value as the original in the second solvent but an R_f of zero in the first solvent.

(4) Double ribulose diphosphate spots - The double spotting of the RDP in the phenol direction has been noted from time to time. On treating each spot with phosphatase it was found that the fastest moving spot gave only pure ribulose, whereas the slowest gave mainly ribulose with traces of other sugars which also form diphosphates (glucose, fructose, and mannose). This slowest moving spot is probably the 1,5-diphosphate whereas the faster moving one is probably the result of the phosphate group on the 5 position migrating to the 4 position to enable the formation of a furanose ring.

APPLICATION OF TECHNIQUES

The application of the apparatus and techniques described earlier to the in vivo study of the mechanism of a biological process is almost unlimited. In the case of photosynthesis, for example, we may study

1. The effect of changing the CO₂ partial pressure.
2. The effect of changing the light intensity.
3. The effect of changing the O₂ partial pressure.
4. The effect of changing the pH
5. The effect of changing the temperature.
6. The effect of many enzyme poisons as for example arsenite, arsenate, and iodoacetamide, to mention but a few.

When the effect of each of the above variables has been worked out, we can choose various combinations of them to obtain the desired effects. As an example of such a technique, the changing of the CO₂ variable has been chosen. This project is perhaps the most difficult because of the technical problems inherent in changing the CO₂ pressure rapidly. The final experimental procedure is naturally the result of many trial experiments. The descriptions of each of these individual experiments would be very lengthy and, since they would serve little useful purpose, they have been omitted. When one is looking for transient changes, the actual experimental conditions become extremely important. If a variable is to be changed, it must be changed abruptly for transient changes to be observed. If the change is too slow, large transient changes will not be observed but rather a slow change to a new steady state will be

noted. In order to design the optimum experimental conditions, certain critical data are required which are peculiar to the particular experimental set up. An illustration of how this data was obtained is given below.

Determination of experimental parameters

CO₂ pressure change. - By turning the recycling system onto the small system (turn stopcock "b", Figure 2), a plot of CO₂ versus time is obtained directly for the particular organism studied. The first differential of this curve when plotted against the ordinate of the curve gives a rate of photosynthesis versus CO₂ partial pressure plot (see Figure 14). This curve was used to help decide the CO₂ pressures between which to work.

Rate of gas flow during transition period. - The size of the transient changes are largely dependent on the rate at which the transition can be made. The effect of various rates of gas flow could be read directly from the analyzer chart (see Figure 15) and this was of great assistance in determining optimum experimental conditions.

Temperature. - By changing the temperature of the water thermostating the illumination vessel it was possible to measure the rate of photosynthesis as a function of temperature (see Figure 16). It was also possible to measure the rate at which the CO₂ could be blown out of solution as a function of temperature (see Figure 17). From this data it was clear that if the CO₂ pressure were to be changed rapidly, high rates of gas flow would have to be used. Thus the first 90% of the CO₂ is removed from solution by a mechanism which is dependent

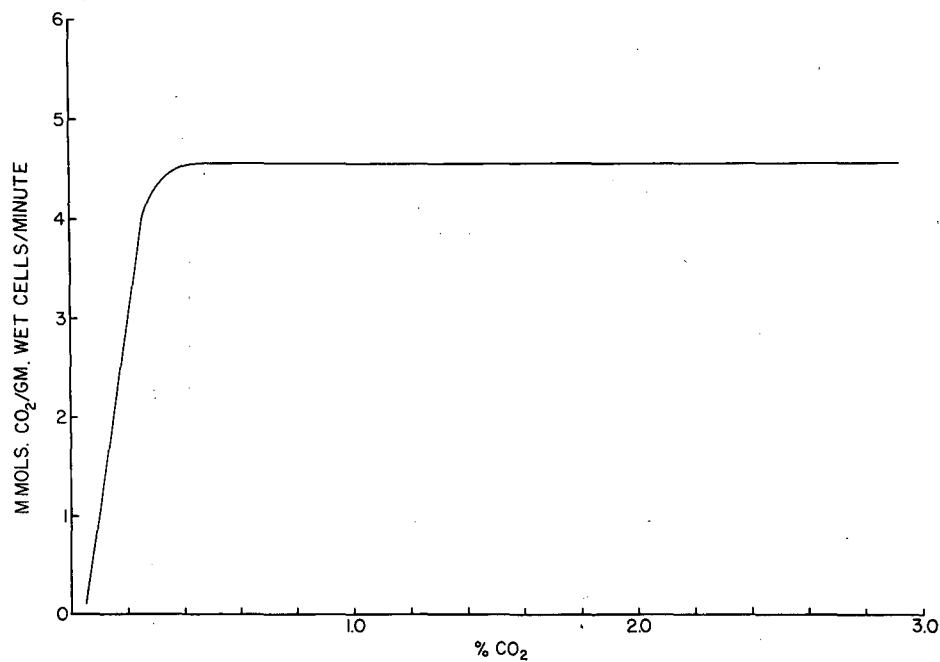

RATE OF PHOTOSYNTHESIS AS A FUNCTION OF CO₂ PRESSURE

MU-7623

SCENEDESMUS 6° C.

(Saturated with respect to light and geometry)

Fig. 14.

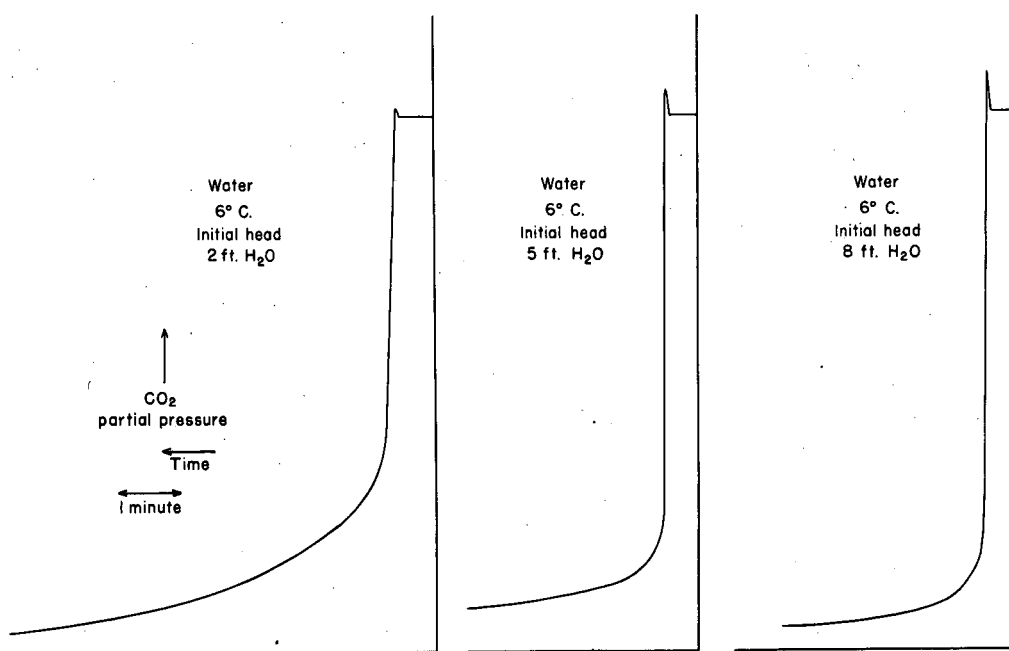

EFFECT OF GAS FLOW RATE ON TIME TAKEN TO CHANGE
FROM ONE CO₂ PARTIAL PRESSURE TO ANOTHER

MU-7821

Fig. 15.

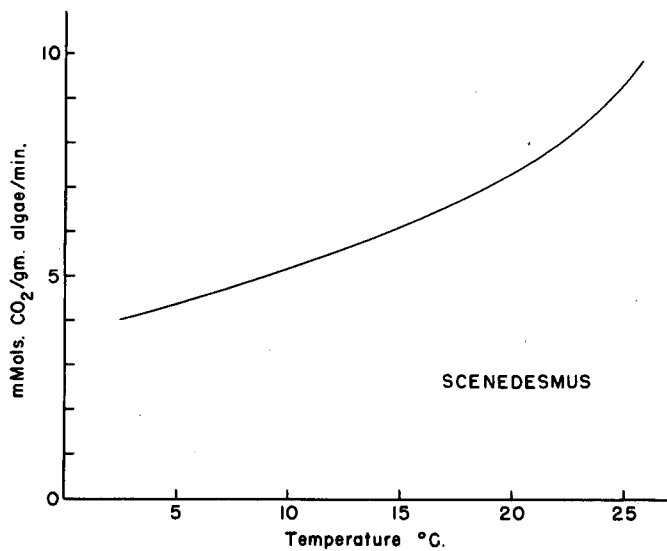

RATE OF PHOTOSYNTHESIS AS A FUNCTION OF TEMPERATURE

MU-7624

Fig. 16.

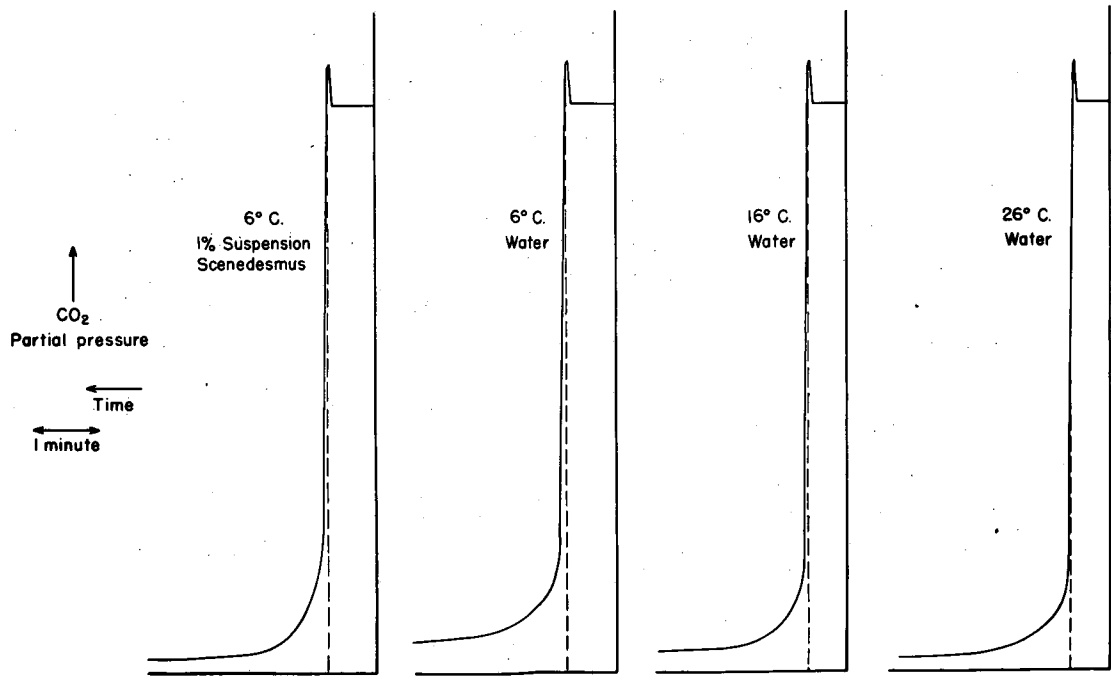

EFFECT OF TEMPERATURE ON TIME TAKEN TO CHANGE
FROM ONE CO₂ PARTIAL PRESSURE TO ANOTHER

MU-7622

Fig. 17.

principally on the rate of gas flow, and the remainder is removed mainly by the photosynthesis (see Figure 17). Thus we see that the activation energy (i.e. temperature dependence) of solution of CO_2 in water is of no practical significance. Since the rate of photosynthesis is less at lower temperatures it becomes clear that the best conditions for a rapid transition (relative) would be to work at 6°C . and at very high gas flow rates.

Geometric saturation. - This term was used to denote the point at which the behavior of the system involving the absorption or evolution of CO_2 ceased to be dependent on the rate at which CO_2 passed between the gas and liquid phases. The rate of CO_2 exchange is clearly dependent on the area of contact, which in turn depends on such geometric factors as the size and number of bubbles. The point of geometric saturation for the system was found by turning down the gas flow until a change was noted in the slope of the line, representing the partial pressure of CO_2 versus time, which was drawn by the recorders. The flow rate at which this change in slope was barely noticeable was taken as the point of geometric saturation, that is, the point where the rate of photosynthesis became dependent on the gas flow rate.

Light saturation. - It was desirable to have light saturation during the experiment. This condition was tested for by turning off one bank of lights and noting if there were any changes in the photosynthetic rate. The actual point at which the system became light dependent can be determined in exactly the same way as for geometric saturation, reducing the light rather than the gas flow.

Sampling

A completely new approach was taken towards the problem of sampling. The procedure was to take a very large number of small samples (10-15 mg. cells), this process not involving too great an expenditure of labor, and then to work up only those that were needed. This procedure enabled one to select the relevant points rather than to work up all points indiscriminately. The samples were taken in 16 x 120 mm. screw-topped test tubes, centrifuged directly and fed into the "octopus" where the whole sample could be evaporated and then placed directly on paper.

Processing of points

General considerations: It was found that most of the phosphatase activity associated with algal extracts is attached to the insoluble cell debris, and is probably attached to the cell walls where it serves the purpose of dephosphorylating the material that is absorbed through the cell walls.***** Some of these phosphatases appear to be very resistant and will survive even room-temperature 80%-ethanol killings. Since most of the intermediates in photosynthesis are phosphorylated compounds, it is desirable that any phosphatase activity in the extract should be kept at a minimum. Samples were, therefore, kept cold while they were in contact with the cell debris to slow down any enzymatic hydrolysis, and the cell debris was centrifuged out as soon as possible. Under these conditions no phosphatase activity was observed, as measured by amounts of free glucose and fructose on the chromatograms.

(*****) This fact may explain why insecticides of the TEP (Tetra ethyl pyrophosphate) type can kill aphids and other animals so effectively yet will not harm plants. (i.e. in plants the insecticide is dephosphorylated while passing through the cell wall).

Experimental procedure

A 1% algal suspension in a dilute phosphate buffer***** was placed in the illumination vessel which was illuminated from each side by a bank of fluorescent tubes (General Electric 20 watt, White), which provided an almost uniform illumination over the whole surface of the vessel, of 7×10^4 ergs/cm.² (ca. 700 footcandles). The temperature of the vessel was maintained at 6° C. during the entire length of the experiment by means of circulating water through the outer jacket with a centrifugal pump. The cells were allowed to photosynthesize for 1 hour with C¹²O₂, after which time the recycling system containing 1% C¹⁴O₂ (10% C¹⁴) was turned into the illumination vessel. After 45 minutes the low system containing 0.003% C¹⁴O₂ with the same specific activity was turned onto the illuminating vessel. Points were taken at suitable intervals as described below.

Treatment of points: 8 cc. of absolute alcohol was placed in 125 mm. x 16 mm. screw-cap test tubes. These were cooled in the cold room to 5° C. and then were weighed to the nearest 0.005 g. and the weights recorded. At the appropriate time in the experiment 1-2 cc. of 1% suspension of algae was run into the tube and the tube immediately recapped and shaken. The tubes were stored at 5° C. for a few hours during which period they were reweighed. The difference in weights gave the quantity of cells in that particular sample. The tubes were placed in water at 80° C. for 2 minutes and then immediately spun down in an International centrifuge (200 r/m for 20 minutes). Such treatment yielded no phosphatase action since no free glucose or fructose were

(*****) 4 mg. KH₂PO₄/liter.

present on the chromatograms. Each sample was then given two 2-3 ml. washings with 20% EtOH and a final washing with EtOH to remove the last of the 20% EtOH extract. A water extract was not given because of the technical density difficulties of centrifuging out cell debris, the density of which was very close to that of water. Furthermore, water extracted polysaccharides which tended to interfere with photosynthetic intermediates on the chromatograms. The samples were stored in tubes in the deep freeze where they appeared to be quite stable. The samples chosen to be worked up were placed in 30 ml. pear-shaped flasks in the "octopus" (Figure 5) and were evaporated down under reduced pressure. When the reduction reached 5 ml. volume, the flasks were removed from the "octopus" and the contents diluted with water to 15 ml. and the flasks again placed on the "octopus" and the samples evaporated to about 4-5 ml., after which they were transferred to 6 ml. polyethylene Spinco centrifuge tubes. At this stage they were frozen in the deep freeze and then placed in a Spinco centrifuge and spun down. The supernate was poured off into an "octopus" flask and the precipitate washed and again spun down. The washing was added to the supernate and the precipitate rejected. (This precipitate contained no photosynthetic intermediates, as was shown by dissolving the precipitate in alcohol, diluting with water and chromatographing, whereupon only material which remained on the origin or ran with a high R_f value in both solvents was obtained.) The combined supernate from above was evaporated to 100 λ on the "octopus" and was then placed on the corner of a sheet of Whatman No. 4 filter paper (dampened with distilled water) by evaporation with a stream of room-temperature air from

a high-speed blower. The papers were run in two dimensions, first in phenol and then in butanol/propionic acid, using the method recommended in the section on chromatography. When dry, a sheet of X-ray film (DuPont X-ray film, 14 x 17 inches, single-coated, blue sensitive, Type 507) was placed on each chromatogram and developed after a suitable time. The position of the compounds on the paper was thus determined and their activity was counted using a Scott large-window Geiger-Mueller tube. A secondary separation of the diphosphate region, the hexose monophosphate region and the triose and pentose regions was obtained by separately phosphatasing and rerunning each of these regions, as described earlier. The results were then plotted for interpretation.

RESULTS

The main purpose of the experiments was two-fold. First, a search was made for new intermediates which conceivably might build up as a result of the peculiar experimental conditions; and second, an effort was made to obtain accurate kinetic curves from which the sequence of intermediates in the photosynthetic cycle could be derived. These curves would also lead to a better understanding of the type of system with which we are dealing when we study a living cell. The results are given in Figures 18a, 18b, 18c, 19a, and 19b. The following convention has been adopted: a smooth curve has been drawn if it was felt that this is a true representation of the data. There are also cases of secondary transient effects, in which case the curve between two points is not known with certainty, and in such cases the points have been joined with straight lines.

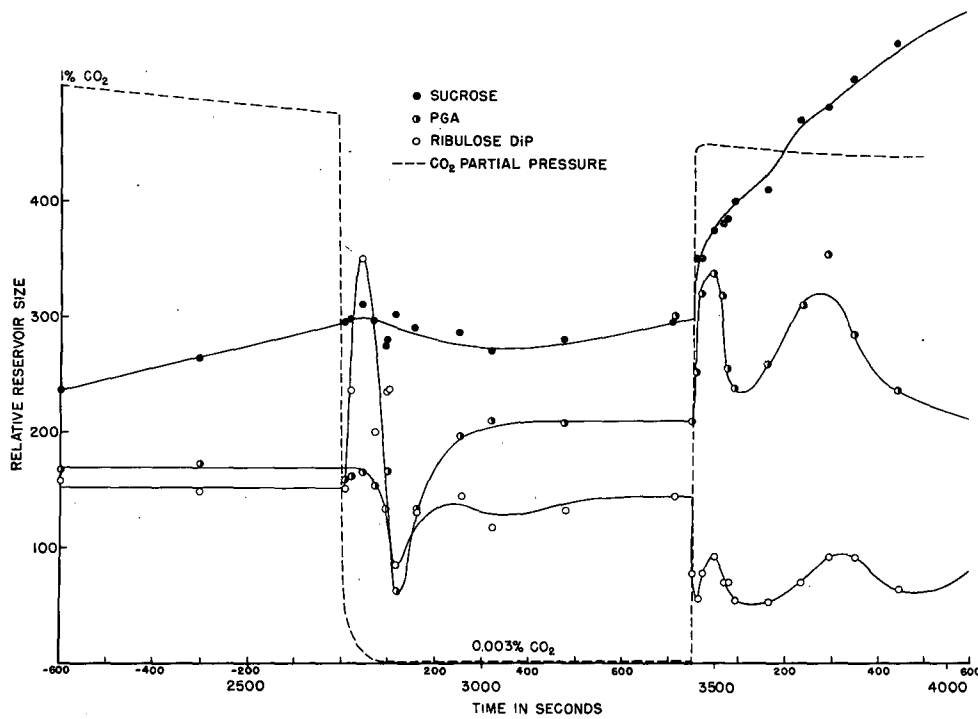

RESERVOIR SIZES AS A FUNCTION OF
CO₂ PARTIAL PRESSURE
SCENEDESMUS AT 6°C.
(26° CULTURE)

MU-7232

Fig. 18a. Long term effects of CO₂ partial pressure changes on reservoir sizes. (Lower scale on x-axis gives time since C¹⁴O₂ turned into the illumination vessel. Upper smaller scale gives times relative to the large changes in CO₂ pressure.)

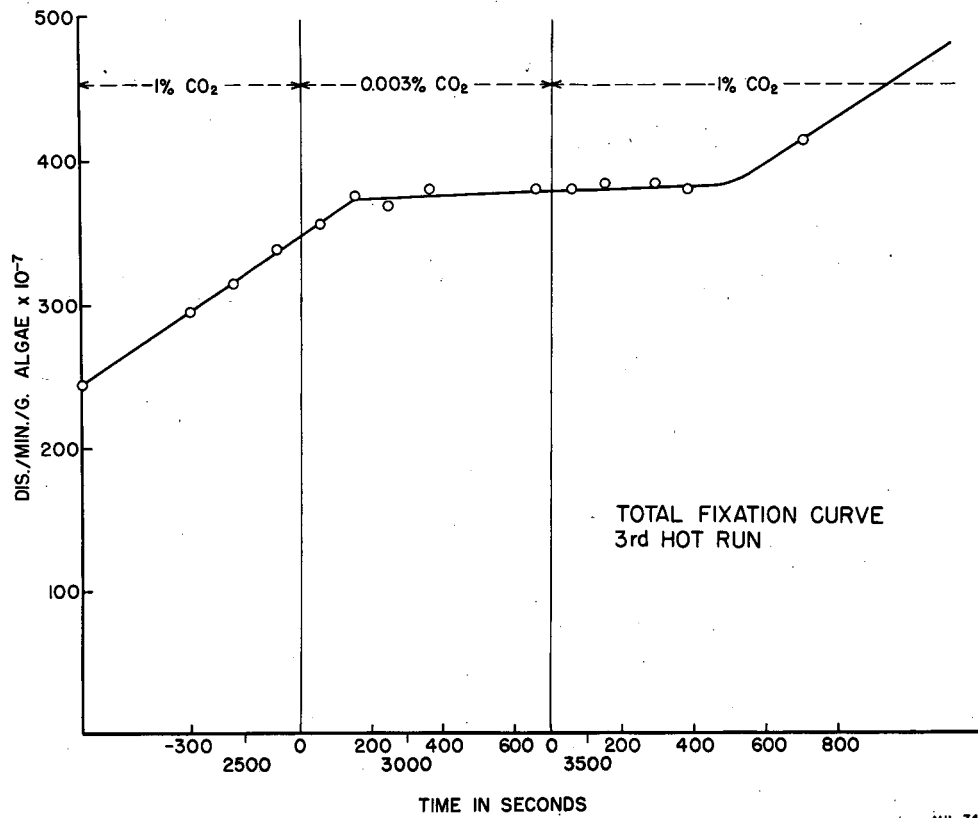
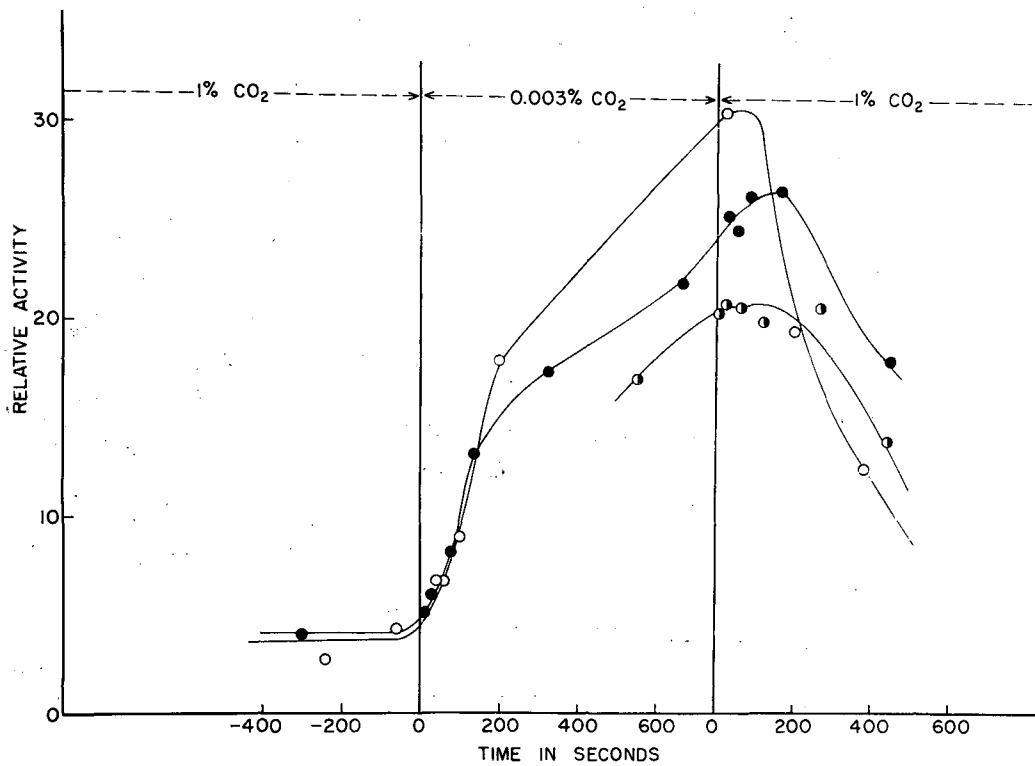

Fig. 18b. Total fixation curve for experiment represented in Fig. 18a.



PRODUCTION OF FREE GLYCOLIC

MU-7437

Fig. 18c. (Scale as for Fig. 18a.) Results from three sets of chromatograms. Because of the volatile nature of glycolic acid results can only be compared among sets of chromatograms.

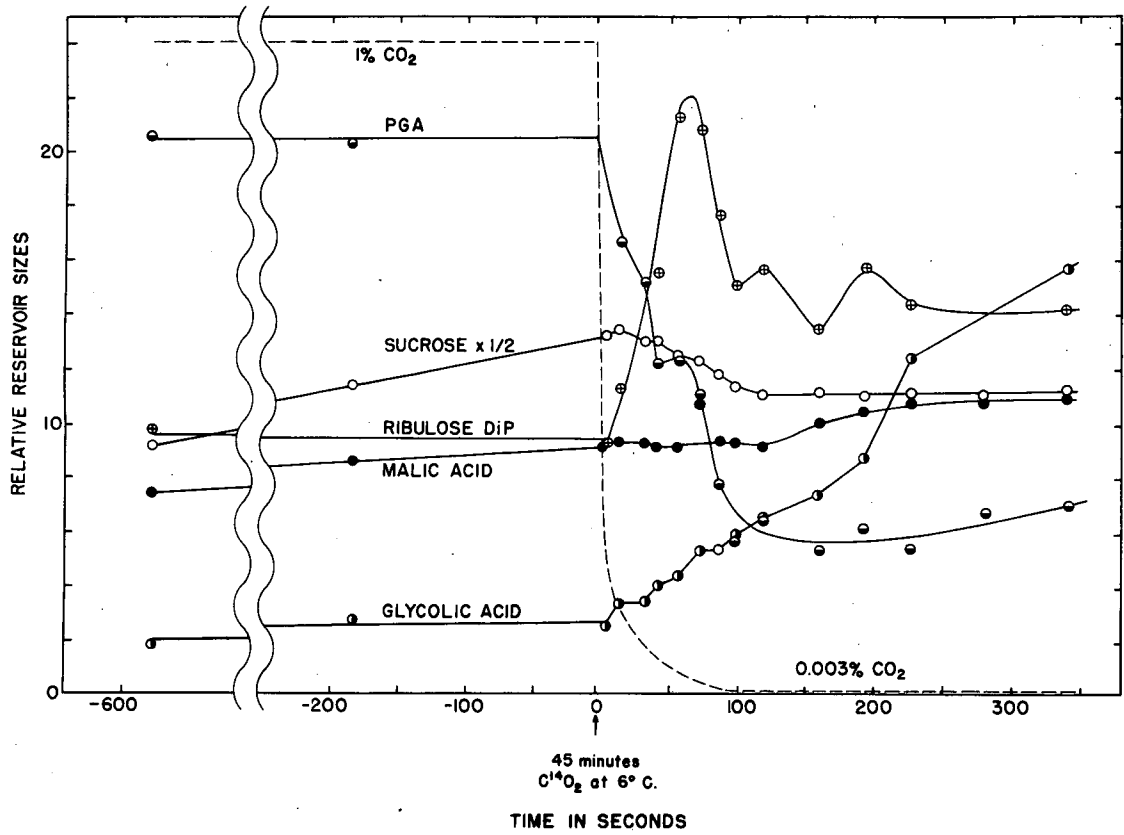

MU-7623

Fig. 19a. Effect of lowering the CO₂ pressure on the pool sizes of certain compounds.

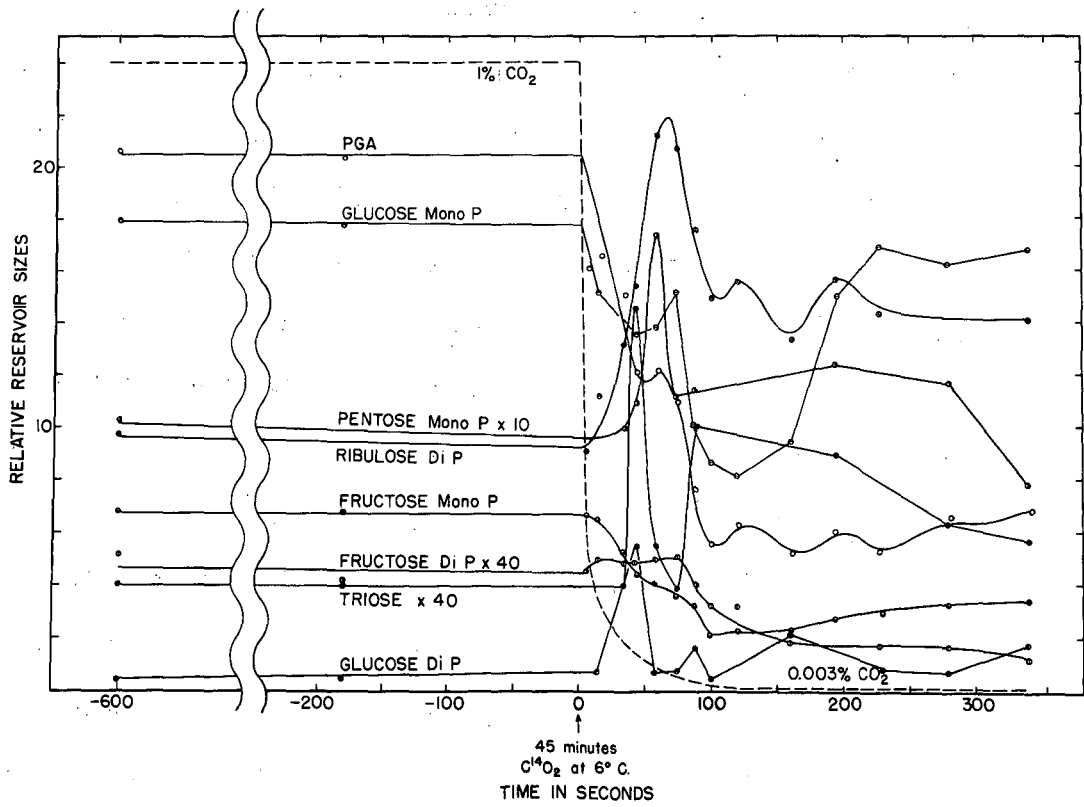

MU-7534

Fig. 19b. Transient effects in the reservoir sizes as a function of time after the CO₂ pressure has been lowered.

DISCUSSION

We are now in a position to discuss the changes in the reservoir sizes when an algae photosynthesizing at steady state in 1% CO₂ is suddenly exposed to 0.003% CO₂.

General effects

For the first 400 seconds (at 6° C.) the concentrations of the photosynthetic intermediates undergo violent oscillations with a period of about 400 seconds (Figure 18a), after which the system settles down to a new steady state which is not so very different from that at 1% CO₂. On returning to 1% CO₂ more oscillations occur only this time in the opposite direction. The lower CO₂ pressures lead to a reduction in the overall rate of carbon fixation (Figure 18b). This change in the rate is not immediate and the change in rate does not become appreciable until the concentration of the ribulose diphosphate has fallen. The lower CO₂ pressures also lead to a reduction in the rate of sucrose synthesis. When the partial pressure of CO₂ is restored to 1% a large increase in the PGA concentration and an associated enormous increase in the rate of sucrose synthesis occurs. The only compound which does not reach a steady-state concentration after 700 seconds at 0.003% CO₂ is glycolic acid, the concentration of which still continues to increase.

CO₂ incorporation step

Perhaps the most striking result is the reciprocal relationship between PGA and RDP. As is seen in Figure 19b, as soon as the CO₂ pressure is dropped the PGA drops sharply and the RDP rises sharply. The

initial slopes of these curves, together with the fact that the other intermediates are still at steady-state concentration, strongly suggest that PGA and RDP are related in a precursor-product relationship, thus

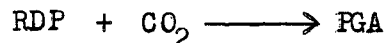

The results imply that RDP is the actual CO_2 acceptor in photosynthesis, or alternatively is related to it by a vanishingly small reservoir, and that PGA is the first observable product of the carboxylation. A hint that RDP might be performing the function of a CO_2 acceptor was obtained by Massini²³ while observing the light and dark steady states. He observed that 30 seconds after turning off the light, the PGA concentration had increased, whereas that of the RDP had decreased. It was, however, uncertain whether the RDP had been carboxylated or had gone back around the regenerative cycle (Figure 20), or for that matter, whether or not the two effects were related since 30 seconds at room temperature (ca. 90 seconds at 6° C.) is a long time, and one is dealing with a very complex network of reactions.

PGA was claimed as the first observable product of photosynthesis¹⁷ since it was the first product to be observable on short-term C^{14}O_2 feeding experiments. This has been interpreted to mean that PGA is the product of the carboxylation step, the tentative assumption being made that there is complete equilibration between the free and enzyme-bound pools of all the intermediates, and furthermore that each new molecule mixes completely with all other members of its species in the cell before being transformed into another molecule. Some doubt has been cast on the validity of these assumptions, and therefore on the validity of the

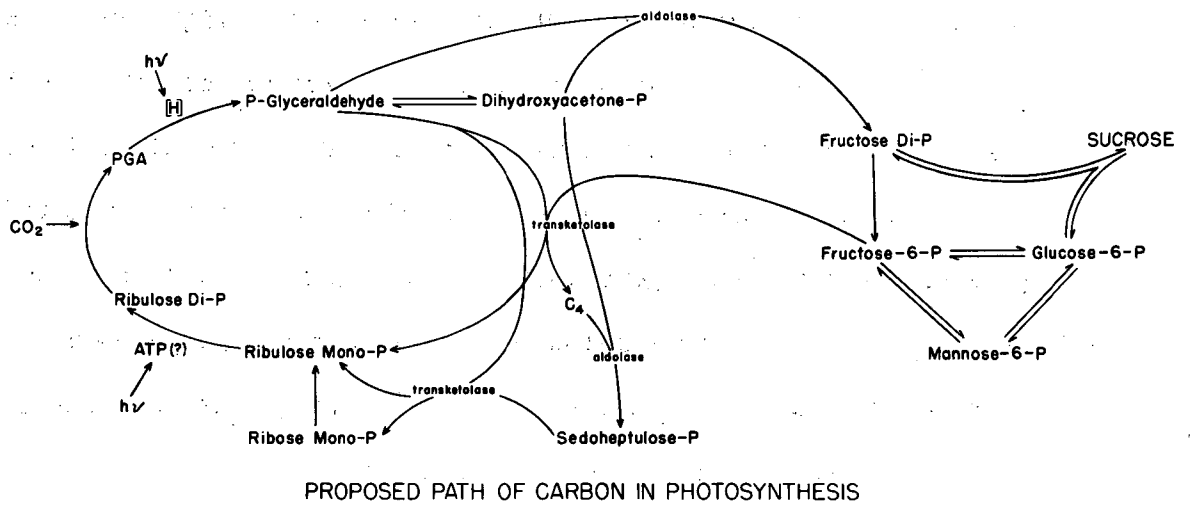

PROPOSED PATH OF CARBON IN PHOTOSYNTHESIS

MU-7533

Fig. 20.

conclusions regarding the position of PGA in the cycle, by the work of Bassham,²¹ who has found that the rate of incorporation of C¹⁴ into many of the photosynthetic intermediates does not extrapolate to zero at zero time as might be expected. Clearly, if a system of enzymatic reactions is in operation in which the ratio of free to enzyme-bound pool sizes and/or the rate constants of the equilibration vary from substrate to substrate it is quite conceivable that when a labeled substrate (CO₂) is introduced

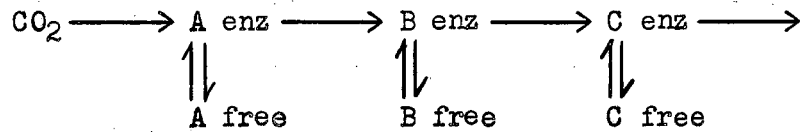

into one end of the system then any or no product might extrapolate to 100% at zero time, depending solely on the parameters of the system. This objection does not hold for the new technique of measuring transients under controlled conditions since we (by definition) are dealing only with actual intermediates, the rates of exchange between enzyme-bound and free pools of material do not enter into our reasoning. Thus the position of PGA as the first observable product of the carboxylation is placed on firmer ground.

Relationships of the intermediates in the regenerative cycle as derived from transient phenomena

If the CO₂ partial pressure is changed very rapidly, large transient changes in the pool sizes of the intermediates in the regenerative cycle are observed. Let us consider the cycle:

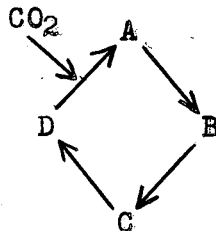

If the CO_2 pressure were suddenly lowered, blocking to a large extent the passage of material from D to A, the reservoirs will rise successively in an anti-clockwise direction, D before C, C before B, B before A, and fall successively in a clockwise direction, A before B, B before C, C before D. Another way of expressing this is to say that the concentration of the compounds on the precursor side of the step affected (in this case the CO_2 incorporation step) go through a maximum or peak with time, the closest one will have the widest peak, the next a narrower peak with its feet inside the first, and the last has the narrowest peak inside the others. One can easily make a distinction between a compound lying in the cycle and one lying to one side but in equilibrium with the cycle: If a compound lies in the cycle it will have a peak whose feet lie inside those of its product but outside those of its precursor. If a compound lies off to one side of the cycle it will have a peak the same shape as its precursor but displaced to a later time. Considering the experimental data (Figure 21) it can be seen that the RDP rises before the RMP which in turn rises before the triose phosphate. Further, the FGA drops first, followed by triose phosphate which in turn is followed by RMP and last of all by RDP. Thus from the kinetic data these compounds lie in the cycle and are related thus

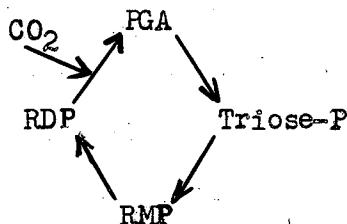

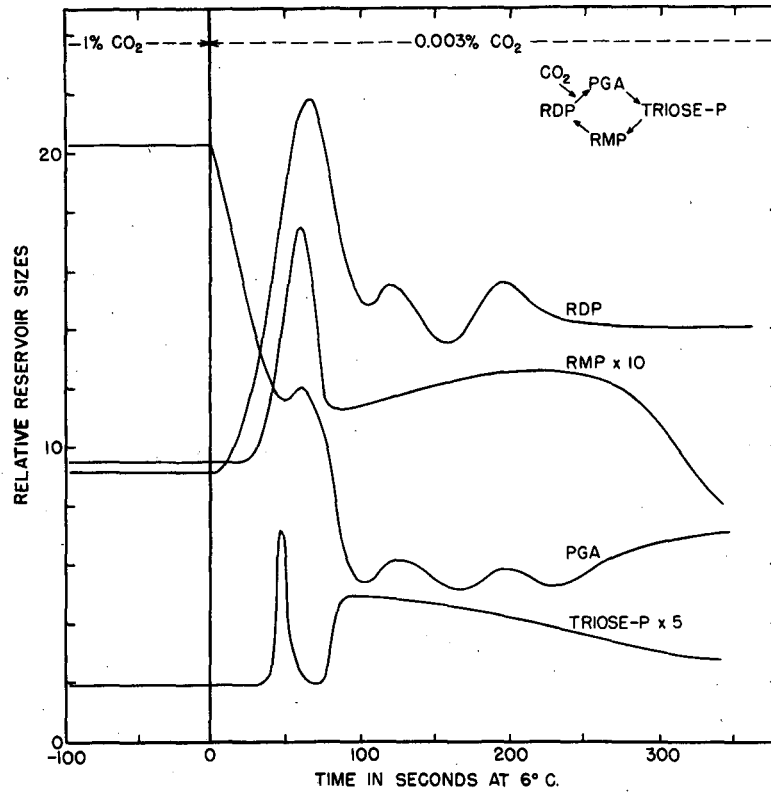

TRANSIENTS IN THE REGENERATIVE CYCLE

MU-7422

Fig. 21. Transients in the regenerative cycle - abstracted from Fig. 19b.

It is interesting to note that the triose peak would be only 5 seconds in width at room temperature. This fact illustrates the tremendous power of the technology employed. From these data the shape of the curve of the true CO_2 acceptor, if it were not RDP, could be predicted to have a peak broader than RDP with a maximum at 60 seconds. A careful search was made for it here with negative results. Thus, since no trace of an intermediate lying between RDP and FGA could be found and since RDP rises almost immediately after the CO_2 pressure is lowered, if the CO_2 acceptor is not RDP, then it must have a vanishingly small reservoir size.

Although the data are not sufficiently accurate to say with certainty, it is probable that the bump on the initial falling leg of the FGA curve is caused by the rapidly rising RDP concentration which helps to maintain the FGA pool before it is itself affected by the receding wave. It might be noted that this whole first transient cycle takes place in the equivalent of 30 seconds at room temperature. After the first transient wave passes, one obtains the results of superimposed waves which are much more difficult to interpret since they involve the whole network of reactions.

These results imply that all of the reactions, with the exception of the carboxylation reaction, are reversible and that an impressed change may be made to travel around the cycle. This concept of bouncing reservoir sizes is rather new in biology where it had been tentatively assumed that the flow of material was from one pool of fixed size to another. The size of these oscillations, as can be seen from the data, are very large

and indicate that unless experiments are done at steady state, any measurements such as rate of labeling, degradation data, and extrapolations to zero time have little meaning.

This new concept of bouncing reservoir sizes casts some doubt on the interpretation of the quantum yield experiments of Warburg's group³ which assumes a steady state during the course of their experiments. Clearly, changes in the distribution of the photosynthetic intermediates during a quantum yield determination would give a quantum yield which would be different than for steady state photosynthesis. These phenomena may account for the discrepancies over which the recent controversy has raged.

Period of the regenerative cycle

When a disturbance is induced in the regenerative cycle, damped oscillations occur which travel around the cycle with a period approximately 225 seconds at 6° C. (ca. 1 minute at room temperature). This fact is interesting in the light of the observed transient effects in such phenomena as CO₂ uptake and fluorescence,^{1,2,3,4} which also have about this period, and points toward some connection of the phenomena.

Criteria of a photosynthetic intermediate

During the early work on the path of carbon in photosynthesis¹⁷ it was thought that if C¹⁴ were incorporated into a compound in short exposure times, it was considered to be a photosynthetic intermediate and lie on the path of CO₂ to carbohydrate. This "criterion of early labeling" has served for several years and with it many photosynthetic intermediates have been identified. The kind of experiments described above, however,

provide a new more definitive criterion which is less subject to disturbance and exception. If the reservoir size of a given compound fluctuates markedly when such photosynthetic variables as light and CO₂ partial pressure are changed abruptly, this becomes a criterion of MASS CHANGES rather than of ATOM EXCHANGE. This difference is probably best demonstrated by the case of malic acid which has been considered by some³³ as a photosynthetic intermediate. It is clear from the kinetic data presented above that the malic acid becomes labeled in short-term experiments by an exchange with C¹⁴O₂ thus

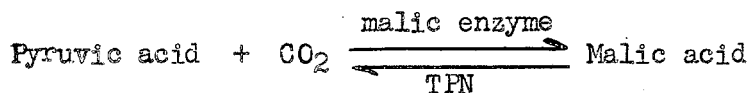

through which reaction a negligible mass of material passes.

Evidence for transketolase system

In a steady-state cell photosynthesizing in 1% CO₂ the level of free glycolic acid is quite low (Figures 18c and 19a). When the CO₂ pressure is reduced to 0.003% the glycolic acid level rises steadily until after 700 seconds its concentration is greater than that of PGA and is still going up. When the CO₂ pressure is restored to 1% the amount of glycolate drops. Since glycolic acid is volatile it is difficult to count accurately. However, individual sets of papers give fairly consistent results within themselves (Figure 18c). These data are explained in terms of the postulated photosynthetic cycle (Figure 20) as follows: The formation of ribulose monophosphate from fructose-6-phosphate and P-glyceraldehyde and the formation of ribose and ribulose monophosphates from sedoheptulose monophosphate both involve a transketolase enzyme

which transfers a glycolyl fragment to P-glyceraldehyde. Now when the rate of photosynthesis is rapid and the flow of material in the cycle is principally in a clockwise direction, there is always a large quantity of P-glyceraldehyde to act as an acceptor for these glycolyl fragments. However, at low CO₂ pressures there is a much lower rate of photosynthesis which means that although the net transfer of material is still in a clockwise direction around the cycle it is much reduced, so that the back reaction (all the reactions are considered to be reversible) becomes relatively much more important. Let us for a moment consider only the portion of the regenerative cycle on the opposite side of the cycle from the CO₂ incorporation step (see Figure 20). Into this system of enzymes is fed triose phosphate and out of it emerges pentose phosphate. Let us consider a pentose phosphate going back through this system (c.f. Figure 20).

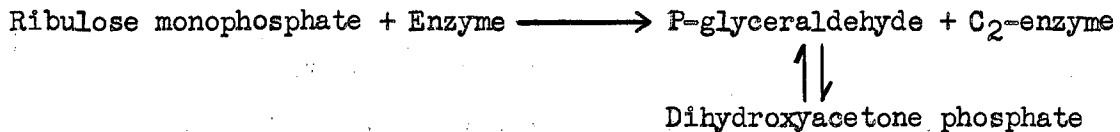

Thus we see that both the C₂ and the C₃ portions of the pentose find themselves in competition with each other for a C₄ fragment. This competition is made even more difficult for the glycolyl fragment when one considers that C₄ reservoir size is very small (it is not chromatographically detectable), since if we consider the rate of reactions of each fragment we have

$$\frac{d C_6}{dt} = k_2 (C_2)^l (C_4)^m$$

$$\frac{d C_7}{dt} = k_1 (C_3)^n (C_4)^o$$

In the first case the (C₂) and (C₄) terms are both small, but in the second at least (C₃) term is large, which will tend to favor this latter route. The net result of the above is that the mean life time of the glycolyl-enzyme complex is increased so that the chance of the glycolyl coming free is increased, thus (by analogy with acetyl CoA):

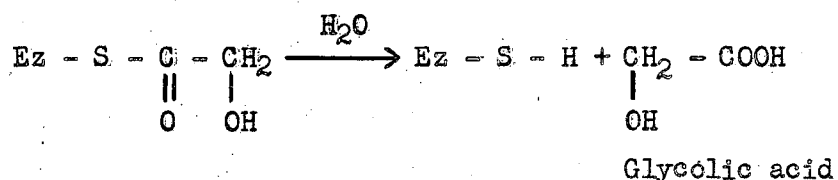

The rate of production of glycolic might be expected to be greater at first (see Figure 18c) since with the initial shortage of P-glyceraldehyde, the normal glycolyl acceptor, an increase in the concentration of the glycolyl fragments might be expected. This is only temporary, however, since the triose phosphate soon rises to a new steady state not too different from the original.

To summarize, we may say that the increase in the concentration of free glycolic acid at low CO₂ pressures implies that an unphosphorylated glycolyl fragment is actually transferred in a reaction which is closely related to the photosynthetic cycle. This reaction is quite likely the transketolase enzyme system isolated by Racker, Horecker and co-workers.^{30,31}

Other effects

The effects close to the CO₂ incorporation step are easy to interpret, but as one goes farther and farther from this step the inter-related effects in the network of reactions make the interpretation

more difficult. The obvious solution is to block another step, for example to study the transients when the light intensity is suddenly reduced. However, an interpretation of some of these effects will be attempted. When the CO_2 pressure is lowered PGA drops, followed by fructose monophosphate and glucose monophosphate. Glucose monophosphate, however, soon recovers and rises rapidly to its new steady state. This rise can be explained if we consider the position of glucose-6-P in the network of reactions (Figure 20). Experiments³² with P^{32} indicate that the rate of equilibration between mannose-6-P, fructose-6-P and glucose-6-P is of the order of one minute at room temperature (about three minutes on our time scale). The mannose could equilibrate with glucose but the fructose would tend to be bled off into the regenerative photosynthetic cycle. Sucrose would probably exert an even greater effect, for as the levels of glucose and fructose phosphates drop, one might expect the sucrose to break down to restore the equilibrium. For every molecule of sucrose which breaks down, one molecule of glucose phosphate and one molecule of fructose phosphate is produced. Now the fructose phosphate is being bled away into the photosynthetic cycle but the glucose phosphate has first to be transformed into fructose phosphate. Thus it might be expected that the glucose phosphate would be the first to recover from the effects of the lowering of the CO_2 pressure. These data imply that the fructose monophosphate is more closely related to the regenerative cycle than glucose monophosphate.

The kinetic curve for glucose diphosphate looks rather typical of a substance which undergoes decomposition, which is not surprising when one considers its structure. The data, however, imply that quite an appreciable fraction of the glucose-6-P we see on our chromatograms was originally glucose diphosphate in the cell.

Thus we see that in the photosynthetic cycle at least, and most probably in the other related networks, a negative feed-back of self-compensating system is operative. At least in the photosynthetic regenerative cycle the system can undergo violent transient changes when a variable is suddenly changed and then returns to a steady state which is not too different from the original (cf. Table II). This can be compared to the electrical analogy of the eddy currents in a piece of iron. Large changes in the distribution of electrons (e.m.f.) can be effected by sudden changes in the magnetic field, but a flow of current soon restores the steady state. From the point of view of a practical research technique, it soon becomes clear that a knowledge of steady-state concentrations of intermediates will be very difficult to interpret in terms of precursor-product relationships. It is doubtful if this knowledge would even provide a moderately sensitive method of distinguishing between possible alternative cycles. If required this would be done by setting up the equations for the steady-state concentrations of the intermediates and solving the resulting simultaneous differential equations. The actual value of these steady-state concentrations probably depends,

Table II
STEADY-STATE CONCENTRATIONS

	Experiment I 22° culture		Experiment II 26° culture	
	1% CO ₂	0.003% CO ₂	1% CO ₂	0.003% CO ₂
FGA	$1.0 \times 10^{-3} \mu\text{M}$	$0.6 \times 10^{-3} \mu\text{M}$	$0.33 \times 10^{-3} \mu\text{M}$	$0.4 \times 10^{-3} \mu\text{M}$
RDP	$0.3 \times 10^{-3} \mu\text{M}$	$1.8 \times 10^{-3} \mu\text{M}$	$0.2 \times 10^{-3} \mu\text{M}$	$0.25 \times 10^{-3} \mu\text{M}$
Ribulose Mono-P			$2.0 \times 10^{-5} \mu\text{M}$	$3.0 \times 10^{-5} \mu\text{M}$
Triose Mono-P			$5.0 \times 10^{-6} \mu\text{M}$	$5.0 \times 10^{-6} \mu\text{M}$

73

however, on the concentrations of each of the enzymes present, which in turn would depend on the previous history of the organism (cf. Table II).

Conclusion

In conclusion one might say that perhaps the most important result of this work is the insight it gives into the complicated interrelated system of chemical reactions which is called life. The living cell is seen as a finely balanced dynamic network of chemical reactions which by its very nature operates as a negative feedback system: the cycle adapting itself to a change impressed on any part of it such that the new steady state is but little removed from the original one. A change of concentration in any intermediate is transmitted around the cycle and results in a compensating change in the corresponding precursor(s). It can thus be understood why an organism can survive changes in its environmental conditions, and how it can adapt itself to new conditions. One can also see how rapidly changing external variables can upset the delicate balance and how these disturbances are damped out. These disturbances can be used as a new tool for the scientist who wishes to study the complicated network of interrelated chemical reactions we call life.

APPENDICES

APPENDICES

Aliquoting compounds

In any quantitative study, it is necessary to know the amount of algae represented on the final paper chromatogram. A search was therefore made for a compound which could be added to the algal suspension so that the amount of this compound on the final papers would then be directly proportional to the amount of algae extract represented on the papers. This material would have to have suitable chromatographic properties and must not interfere with any important photosynthetic intermediates. Many C¹⁴-labeled compounds were tested but few had desirable chromatographic characteristics, and most of them were metabolized by the algae. At first, C¹⁴-labeled EDTA (ethylene diamine tetra acetic acid) seemed promising since it was not metabolized by the algae to any measurable extent after 2 hours. However, it did not run to one spot and did not give reproducible chromatograms, probably due to its strong chelation properties. Fission product Sr⁹⁰ was also tried and found to be a possible aliquoting compound. If carrier Sr is added, it runs into the hexose monophosphate region, but if no carrier is added, it will remain on the origin. Because of its hard β' it can be detected separately if a second film is placed on top of the first. Its daughter product,

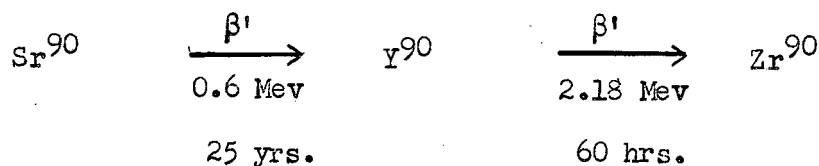

complicates matters somewhat but this should not be an insuperable difficulty. The greatest objection to Sr⁹⁰ is the health hazard, because it is a bone seeker with a strong β (2.18 Mev), and a 25 year half life. For this reason, it was not used. Perfecting a cold-killing procedure (described above) enabled a method of aliquoting by weight. However, if a suitable aliquoting material could be found it would make the procedure much simpler.

Glucose and galactose cyclic phosphates

(cf. Leloir³⁵) Certain photosynthetic experiments yielded a spot which had the same R_f value as the hexose monophosphates in the acid direction and about twice the R_f value in the phenol direction. On investigation, it was found that all the extracts were alkaline, the usual reason being that the cells had used up most of the CO₂ converting the HCO₃⁻ to OH⁻. On cutting out and partially phosphatasing this spot, three spots appeared which were, (1) the free sugars, (2) some of the original, and (3) a spot in the hexose monophosphate region. This latter spot was probably a half-opened cyclic phosphate, i.e. a 1- or 2-monophosphate. The free sugar spot gave two spots when chromatographed two-dimensionally in phenol, butanol/pyridine/water solution, and these two spots were shown to be glucose and galactose when chromatographed in the same solvents. In picric acid/t-butanol-water solvent the original spot gave two spots. When some normal algal extract was treated with NH₃ the same spot appeared with a simultaneous disappearance of the UDPG spot. The conclusion from the above was that alkaline conditions can destroy UDPG with the simultaneous

production of glucose and galactose cyclic phosphates. The practical use of the above is in the conversion of UDPG into cyclic phosphates before picric acid chromatography. This prevents glucose and galactose from being run into the hexose monophosphate region by the decomposition of UDPG.

Degradation of ribulose diphosphate

It had been reported that when ribulose diphosphate is treated with dimethylamine it is converted into PGA and phosphoglycolic acid. If these compounds could be separated quantitatively by paper chromatography, one would have a very good method of degradation of ribulose diphosphate. Since good methods do exist for the degradation of PGA and phosphoglycolic acid, complete data on every constituent carbon could be obtained. A necessary part of the data is the ratio of PGA to phosphoglycolic acid and this is only obtainable if there is no origin sticking. This problem was solved and its solution is discussed in an earlier section. When a sample of ribulose diphosphate was treated with dimethylamine, most of the activity disappeared off of the paper as a volatile compound. However, if the ribulose diphosphate spot from old chromatograms was rerun, several spots were obtained among which were PGA and phosphoglycolic acid. It is thought that the reported experiment involved the destruction of the ribulose diphosphate by the alkali, leaving unchanged the PGA and phosphoglycolic acid. A series was run at different pH's, and it was found that splitting would occur even at pH 7. Many unidentified spots were obtained and the reaction was obviously not simple and clear cut.

These spots were not caused by bacteria since the spots also occurred in the presence of toluene and even in 50% ethanol. A spot near the origin could be removed by dilution of the reaction mixture by a factor of 10,000 and was considered to be the aldol condensation product of phosphoglyceraldehyde before it was oxidized. PGA and phosphoglycolic acid could be obtained, but only in very small overall yield, most of the activity volatilizing off the paper probably as a furanose type of molecule. Since another method of degradation was developed in the group, this project was abandoned.

Non-enzymatic fixation of CO₂ - storage of RDP

The non-enzymatic reaction between CO₂ and ribulose diphosphate was investigated. A stream of pure CO₂ was bubbled through a solution of uniformly labeled RDP for 12 hours and the result chromatographed. Pure RDP was recovered. This is of great practical importance in the storage of RDP since above pH 4 it tends to decompose to a volatile substance and at lower pH it tends to undergo hydrolysis.

35-cent oxygen analyzer

It has been shown that an inexpensive oxygen analyzer can be made from Eveready 1002 E hearing-aid batteries. These batteries are of the C/OH⁺/Zn type with the carbon on the outside so that the atmospheric oxygen can be used as a depolarizer. If the carbon surface is covered up leaving only a small hole open to the atmosphere and if the cell is shorted through a low resistance to keep it polarized, the current (which is related to the rate of diffusion of O₂ through

the small hole) is directly proportional to the O_2 partial pressure up to about 20% O_2 . The response time can be made of the order of a minute. The consumption of O_2 is about 1-2 cc./hr. while in use.

REFERENCES

1. R. van der Veen, *Physiol. Plant.*, 2, 287 (1949).
2. J. Franck, C. S. French and T. T. Puck, *J. Phys. Chem.*, 45, 1268 (1941).
3. D. Burk and O. Warburg, *Z. Naturf.*, 6b(1), 12 (1951).
4. E. D. McAlister and Jack Myers, *Smithsonian Misc.*, 99, 37 (1940).
5. E. S. Nielsen, *Physiol. Plant.*, 6, 316 (1953).
6. S. Ruben, M. Randall, M. Kamen and J. L. Hyde, *J. Am. Chem. Soc.*, 63, 877 (1941).
7. R. Hill, *Nature*, 139, 881 (1937).
8. R. Hill, *Proc. Roy. Soc., London*, 127B, 192 (1939).
9. S. Ruben, W. Z. Hassid and M. D. Kamen, *J. Am. Chem. Soc.*, 61, 661 (1939).
10. S. Ruben, M. D. Kamen and W. Z. Hassid, *J. Am. Chem. Soc.*, 62, 3443 (1940).
11. S. Ruben, M. D. Kamen and L. H. Perry, *J. Am. Chem. Soc.*, 62, 3450 (1940).
12. S. Ruben and M. D. Kamen, *J. Am. Chem. Soc.*, 62, 3451 (1940).
13. M. Calvin and A. A. Benson, *Science*, 107, 476 (1948).
14. W. Stepka, A. A. Benson and M. Calvin, *Science*, 107, 304 (1948).
15. A. A. Benson and M. Calvin, *Cold Spring Harbor Symp. on Quant. Biol.*, 13, 6 (1948).
16. M. Calvin and A. A. Benson, *Science*, 109, 140 (1949).
17. A. A. Benson, J. A. Bassham, M. Calvin, T. C. Goodale, V. A. Haas and W. Stepka, *J. Am. Chem. Soc.*, 72, 1710 (1950).
18. R. Conden, A. H. Gordon and A. J. P. Martin, *Biochem. J.*, 38, 224 (1944).
19. A. A. Benson, M. Calvin, V. A. Haas, S. Aronoff, A. G. Hall, J. A. Bassham and J. W. Weigl, "Photosynthesis in Plants," Iowa State Coll. Press, 1949, Ch. 19, p. 381.

20. M. Gibbs, *J. Biol. Chem.*, 179, 499 (1949).
21. J. A. Bassham, A. A. Benson, L. D. Kay, A. Z. Harris, A. T. Wilson and M. Calvin, *J. Am. Chem. Soc.*, 76, 1760 (1954).
22. A. A. Benson, S. Kawaguchi, P. M. Hayes and M. Calvin, *J. Am. Chem. Soc.*, 74, 4477 (1952).
23. M. Calvin and Peter Massini, *Exper.*, 8, 445 (1952).
24. C. S. Hanes and F. A. Isherwood, *Nature*, 164, 1103 (1949).
25. R. S. Bandurski and B. Axelrod, *J. Biol. Chem.*, 193, 405 (1951).
26. D. C. Mortimer, *Can. J. Chem.*, 30, 653 (1952).
27. P. D. Mitchell and J. Moyle, *J. Gen. Microbiol.*, 5, 966 (1951).
28. Hans G. Boman, *Nature*, 170, 703 (1952).
29. G. N. Kowkabany and H. G. Cassidy, *Anal. Chem.*, 24, 643 (1952).
30. E. Racker, G. de la Haba and I. G. Leder, *Arch. Biochem. Biophys.*, 48, 238 (1954).
31. B. L. Horecker, P. Z. Smyrniotis and H. Klenow, *J. Biol. Chem.*, 205, 661 (1953).
32. M. Goodman, D. F. Bradley and M. Calvin, *J. Am. Chem. Soc.*, 75, 1962 (1953).
33. S. Ochoa and W. Vishniac, *J. Biol. Chem.*, 198, 501 (1952).
34. H. Kautsky and A. Hirsch, *Naturwissenschaften*, 19, 964 (1931).
35. L. F. Leloir, "Phosphorus Metabolism, I", Johns Hopkins Press, Baltimore, 1951, p. 67.

ACKNOWLEDGEMENTS

I wish to acknowledge the instruction and kind cooperation received from Dr. Andrew A. Benson and other members of the Radiation Laboratory during the course of this work. I am very grateful to Alice Holtham for typing the manuscript and for the excellent job she made of the drawings.

It has been my good fortune to have as my research director Professor Melvin Calvin, whose wide breadth of knowledge and progressive outlook on science has provided a long-lasting inspiration.