

UCSF

UC San Francisco Previously Published Works

Title

Generation of a germ cell-specific mouse transgenic cherry reporter, Sohlh1-mCherryFlag

Permalink

<https://escholarship.org/uc/item/1pd0842k>

Journal

Genesis, 51(1)

ISSN

1526-954X

Authors

Suzuki, Hitomi
Dann, Christina Tenenhaus
Rajkovic, Aleksandar

Publication Date

2013

DOI

10.1002/dvg.22347

Peer reviewed



Published in final edited form as:

Genesis. 2013 January ; 51(1): 50–58. doi:10.1002/dvg.22347.

Generation of a germ cell-specific mouse transgenic CHERRY reporter, *Sohlh1-mCherryFlag*

Hitomi Suzuki^a, Christina Tenenhaus Dann^b, and Aleksandar Rajkovic^a

^aMagee-Womens Research Institute, Department of Obstetrics, Gynecology and Reproductive Sciences, University of Pittsburgh, Pittsburgh, PA 15213, USA

^bIndiana University, Department of Biology, Bloomington IN 47405-7102

SUMMARY

Visualization of differentiating germ cells is critical to understanding the formation of primordial follicles in the ovary, and the commitment of spermatogonial stem cells to differentiation. We engineered and generated a BAC transgenic mouse line, *Sohlh1-mCherryFlag* (*S1CF*), under the direction of the native *Sohlh1* promoter. *Sohlh1* is a germ cell-specific gene that encodes the basic helix-loop-helix (bHLH) transcriptional regulator that is essential in oogenesis and spermatogenesis. *Sohlh1* expression is unique, and is limited to perinatal and early follicle oocytes and differentiating spermatogonia. The *Sohlh1-mCherryFlag* transgene was engineered to fuse SOHLH1 to the red fluorescent protein CHERRY with 3-tandem-FLAG tags. *S1CF* animals fluoresce specifically in the oocytes of perinatal ovaries and small follicles in adult ovaries, as well as in spermatogonia, a pattern that is similar to endogenous SOHLH1. Moreover, *S1CF* rescued germ cell loss and infertility in both male and female *Sohlh1*^{-/-} animals. The FLAG-tag on *S1CF* was effective for immunostaining and immunoprecipitation. The *Sohlh1-mCherryFlag* transgenic mouse provides a unique model to study early germ cell differentiation, as well as *in vivo* imaging and purification of differentiating germ cells.

Keywords

oocyte; oogenesis; spermatogonia; spermatogenesis; imaging

Live imaging is important in understanding the localization and movements of specific cell types and their responses to genetic and environmental manipulations. Fluorescent proteins engineered under the control of specific promoters are useful in the study of germ cell development. For example, *Ng3*-EGFP transgenic mice express EGFP in spermatogonia, and time-lapse analyses have contributed significantly to our understanding of spermatogonial proliferation and renewal (Yoshida et al., 2007). *Oct4-ΔPE-EGFP* transgenic mice have been useful in the study of PGC migration mechanisms (Molyneaux et al., 2001; Molyneaux et al., 2003; Runyan et al., 2006; Takeuchi et al., 2005). However, *Oct4* expression ceases around embryonic day (E) 16.5 in the ovary and re-establishes itself postnatally. Hence, *Oct4* is not useful in the study of perinatal events, such as the transition from germ cell cysts to primordial follicles. Promoters that drive *Gdf9* and *Zp3* expression act postnatally, and have been used to engineer *ZP3*-EGFP and *GDF9*-EGFP for various postnatal analyses such as cellular localization and functional analysis of promoter elements (Baibakov et al., 2007; Hoodbhoy et al., 2006; Philpott et al., 1987; Yan et al., 2006).

Correspondence should be addressed to: Aleksandar Rajkovic, M.D., Ph.D., Magee-Womens Research Institute, Department of Obstetrics, Gynecology and Reproductive Sciences, University of Pittsburgh, 204 Craft Avenue, Pittsburgh, PA 15213, USA, Tel: +1-412-641-8635, Fax: +1-412-641-6156, rajkovic@upmc.edu.

Sohlh1 expression is confined to the germ cell lineage in the mouse. Embryonic female gonads commence *Sohlh1* mRNA expression circa E15.5, at a time when most female germ cells entered meiosis, and continue to express *Sohlh1* mRNA until birth. Postnatally SOHLH1 protein is strongly expressed in oocytes where its expression is confined to the germ cell cysts and primordial follicles. In the adult ovary, SOHLH1 expression is uniquely observed in primordial and primary follicles but not in secondary or later stage ovarian follicles (Pangas et al., 2006). We therefore generated a *Sohlh1* reporter mouse line that will be useful in studying perinatal female germ cells and small ovarian follicles.

We selected *Sohlh1*-containing BAC clone bMQ416B15 (129AB22 mouse strain), with 59 kb and 91 kb of 5' and 3' -flanking sequences, respectively. This BAC clone was recombineered to produce a *BAC-Sohlh1-mCherryFlag (S1CF)* construct as previously described (Fig. 1) (Warming et al., 2005). A *Galk* cassette was transiently inserted by recombineering right in front of the *Sohlh1* stop codon and then replaced by *mCherryFlag* cassette via recombineering (Fig. 1). The *S1CF* construct was designed to produce a protein fusion of SOHLH1 to CHERRY and 3 tandem FLAG tag repeats (*S1CF* protein). In order to study rescue of *Sohlh1*^{-/-} mice by *S1CF*, we devised a PCR strategy using primers G4 and S13UR1 to distinguish *Sohlh1*^{+/-}/*S1CF* from *Sohlh1*^{-/-}/*S1CF* mice (Fig. 1). We identified five transgenic founder lines, and two of the five founder lines (*S1CF*#1 and #2) showed strong FLAG expression in the testis by Western blotting (Fig. 4E for #1 and data not shown for #2). *S1CF*#1 founder was selected for the current analysis. We observed bright CHERRY signals in *S1CF*#1 using either a dissection microscope with fluorescence filter or with confocal microscopy (Fig. 2, 3 and data not shown).

We examined the expression pattern of CHERRY fluorescence in *S1CF* mice during female and male gonadal development. To avoid confusion with background staining of antibodies, we directly observed CHERRY signals in fixed tissues without immunostaining. In female gonads, the endogenous SOHLH1 expression was first observed circa embryonic day (E) 15.5 in a small subset of germ cells, and then expanded to all germ cells in the newborn ovary (Fig 2A–C) (Pangas et al., 2006). The expression of CHERRY in *S1CF* mice emerged by E17.5 in many germ cells (Fig. 2E and F). In postnatal ovaries, CHERRY expression was observed in primordial and primary follicles but not in secondary or later stage follicles, a pattern that was identical to endogenous SOHLH1 (Fig. 2G–I) (Pangas et al., 2006). The sub-cellular localization of CHERRY was also similar to endogenous SOHLH1, being predominantly cytoplasmic in many oogonia and oocytes (Fig. 2C, inset of G, and F–I).

In male gonads, endogenous SOHLH1 expression commenced circa E14–15 in all germ cells, and was dramatically reduced in perinatal gonads (Fig. 3A–C and G). SOHLH1 expression resumed by postnatal day 4 in a subset of spermatogonia (Ballou et al., 2006). *S1CF*CHERRY signal was observed in all male germ cells at E15.5 and mimicked endogenous SOHLH1 (Fig. 3A, B, D and E). Moreover, the CHERRY signal was cytoplasmic in location, as was the endogenous SOHLH1 protein. CHERRY signal was observed in postnatal day (PD) 1 gonocytes in which endogenous SOHLH1 was not detected (Fig. 3G and J), indicating that either CHERRY expression resumed earlier than endogenous SOHLH1; alternatively, the anti-SOHLH1 antibody may not be as sensitive at that stage. In adult testis, endogenous SOHLH1 was expressed in both undifferentiated and differentiating spermatogonia but not in GFRA1-positive spermatogonia (Suzuki et al., 2012). GFRA1 marks the most primitive undifferentiated spermatogonia, including spermatogonial stem cells. CHERRY was also exclusively observed in GFRA1-negative undifferentiated spermatogonia and differentiating spermatogonia (Fig. 3H, I, K and L). Although endogenous SOHLH1 was clearly localized in the nuclei of spermatogonia, CHERRY was observed in both the cytoplasm and nuclei (inset of Fig. 3I and L) (Suzuki et al., 2012).

Unexpectedly, CHERRY was not detected in all GFRA1-negative spermatogonia and early follicular stages of oocytes in *Sohlh1^{+/-}/S1CF*, cell types where endogenous SOHLH1 is usually expressed. However, when S1CF was expressed in *Sohlh1* deficient mice (*Sohlh1^{-/-}/S1CF*), CHERRY expression was present in all GFRA1-negative spermatogonia and early follicular stages of oocytes (data not shown). These results suggest that the *S1CF* transgene expression maybe negatively regulated by endogenous SOHLH1.

We derived spermatogonial cell lines from the testes of PD21 *Sohlh1^{+/-}/S1CF* pups and non-transgenic siblings as a control (“SOC1” and “NEG1” cell lines, respectively) in order to examine whether the *S1CF* transgene could be utilized to visualize spermatogonial differentiation by *in vitro* live imaging. We used a method developed originally by Shinohara et al. (Kanatsu-Shinohara et al., 2003) with which cultures can be established containing a mixture of spermatogonial stem cells and differentiating progenitor cells. Accordingly, we have previously observed that a subset of cells in such cultures expresses SOHLH1 protein (Dann et al., 2008). Indeed, we observed CHERRY fluorescence in a small subset of the cultured spermatogonia in the transgenic SOC1 cells, but not in the NEG1 cells (Fig. 4A–C), consistent with the idea that the cultured cells comprise a heterogeneous population of undifferentiated spermatogonia with a subset of cells beginning to differentiate (Dann et al., 2008). The number of cells expressing CHERRY was lower than anticipated and the low expression may have resulted from negative regulation by the endogenous SOHLH1. Nonetheless, the CHERRY expression from the S1CF transgene is expected to be a useful tool for live imaging analysis of spermatogonial differentiation for a variety of experiments.

We also examined whether the FLAG-tag is effective for immunostaining and immunoprecipitation. In paraffin sections, the anti-FLAG (M2) antibody clearly detected S1CF protein in adult oocytes and spermatogonia (Fig. 4D and E). Furthermore, the antibody immunoprecipitated S1CF from the PD7 testes lysates. The endogenous SOHLH2 protein was co-immunoprecipitated with S1CF by anti-FLAG as well as by the anti-SOHLH1 antibody (Suzuki et al., 2012). The endogenous SOHLH1 was also co-immunoprecipitated with S1CF, indicating that SOHLH1 homodimerizes with the transgenic SOHLH1 protein *in vivo* (Fig. 4F).

Finally, we examined whether the S1CF fusion protein rescued *Sohlh1^{-/-}* pathology. We crossed *Sohlh1^{+/-}/S1CF* males with *Sohlh1^{+/-}* females and obtained *Sohlh1^{-/-}/S1CF* pups. Ovaries of *Sohlh1^{-/-}* 7 weeks old females were significantly smaller than wild type *Sohlh1^{+/-}* ovaries due to the lack of oocytes (Fig. 5A–C) (Pangas et al., 2006). *Sohlh1^{-/-}/S1CF* ovaries were comparable to *Sohlh1^{+/-}* ovaries and were histologically indistinguishable from the wild type (Fig. 5A and D). We also tested *Sohlh1^{-/-}/S1CF* fertility by crossing adult *Sohlh1^{-/-}/S1CF* females with wild type males. The fertility of *Sohlh1^{-/-}/S1CF* females was comparable to that in *Sohlh1^{+/-}* females (Fig. 5J). We also tested the ability of the S1CF fusion protein to rescue male infertility due to *Sohlh1* deficiency. Testes of *Sohlh1^{-/-}* 7 weeks old males were significantly smaller than those of wild type or *Sohlh1^{+/-}* males due to the defect in spermatogonial differentiation (Fig. 5E–G) (Ballow et al., 2006). *Sohlh1^{-/-}* testes were rescued in *Sohlh1^{-/-}/S1CF* males and were indistinguishable from *Sohlh1^{+/-}* testes (Fig. 5E, H and I). *Sohlh1^{-/-}/S1CF* male fertility was comparable to *Sohlh1^{+/-}* males, whereas *Sohlh1^{-/-}* males without the S1CF fusion protein did not impregnate wild type females (Fig. 5K). It is also noteworthy that both *Sohlh1^{+/-}/S1CF* females and males retained normal fertility after 1 year or more (data not shown). *S1CF* homozygous animals did not display gross phenotypic abnormalities.

Our results indicate that the S1CF fusion protein, derived from the *S1CF* transgene, can support normal oogenesis and spermatogenesis. The *S1CF* transgenic line will be a useful model to study both female and male germ cell development.

MATERIAL AND METHODS

BAC-Sohlh1-mCherryFlag Construct

The BAC clone bMQ416B15 (129AB22 strain), containing a 59 kb 5′-flanking region and a 91kb 3′-flanking region of the *Sohlh1* gene, was modified to ultimately generate a *BAC-Sohlh1-mCherryFlag* construct via recombineering as previously described (Warming et al., 2005). Using pGalK as a template and *Sohlh1-galK-F1* and *Sohlh1-galK-R1* primers, a DNA fragment for homologous recombination was amplified by PCR using PrimeSTAR DNA HS polymerase (Takara Bio). The *Sohlh1-galK-F1* primer contains a 50bp 5′-flanking sequence of the *Sohlh1* stop codon and 20bp of the galK homologous region including ATG. The *Sohlh1-galK-R1* primer contains a 50bp complement sequence of the 3′-flanking region of the *Sohlh1* stop codon and 20bp of the galK complement sequence including the stop codon. Homologous recombination with this PCR fragment in the SW102 harboring BAC clone bMQ416B15 resulted in insertion of the *GalK* cassette into the *Sohlh1* COOH-terminal (*BAC-Sohlh1-GalK*). We also constructed pmCherry-3xFlag-C1 by inserting the 170bp 3-tandem-repeats of Flag (derived from pcDNA3.1-3xFlag kindly provided from A. Suzuki) into pmCherry-C1. Using pmCherry-3xFlag-C1 as a template, and *Sohlh1-mCherry-F1* and *Sohlh1-Flag-R1* primers, a DNA fragment for a second homologous recombination was amplified by PCR using PrimeSTAR DNA HS polymerase. In the same manner as *GalK* insertion, *Sohlh1-mCherry-F1* contains a 50bp 5′-flanking sequence of the *Sohlh1* stop codon and 20bp of the mCherry homologous region including ATG. The *Sohlh1-Flag-R1* primer contains a 50bp complement sequence of the 3′-flanking region of the *Sohlh1* stop codon and 20bp of the galK complement sequence including stop codon. The homologous recombination with this PCR fragment in SW102 harboring *BAC-Sohlh1-GalK* resulted in insertion of *mCherry-3xFlag* into the *Sohlh1* c-terminal (*BAC-Sohlh1-mCherryFlag*). The following primer sequences were used: *Sohlh1-galK-F1* (3′-GCCTGGCCCT GAAGGATGAA GCGGACAGCA TCTTCCCTGA CTTTTTCCCC CCTGTTGACA ATTAATCATC GGCA -5′), *Sohlh1-galK-R1* (3′-CCAGGCACAG GACAGCTCCC CAGCAAATA AACTCTGGGG GACTCAGCTA TCAGCACTGT CCTGCTCCTT -5′), *Sohlh1-mCherry-F1* (3′-GCCTGGCCCT GAAGGATGAA GCGGACAGCA TCTTCCCTGA CTTTTTCCCC ATGGTGAGCA AGGGCGAGGA -5′) and *Sohlh1-Flag-R1* (3′-AGCCCAAAT ACAACACCCA GGCACAGGAC AGCTCCCCAG CAACTAAAC TCTGGGGGAC TCAGCTATCA GTCATCGTCA TCCTTGTAAT -5′). Both PCR products were approximately 1kb.

Generation of *BAC-Sohlh1-mCherryFlag* Transgenic Mice and Animal Care

Following linearization by restriction enzyme *P*sce-I (New England Biolabs), the DNA without vector sequences was gel purified using CHEF-DR II Pulsed Field Electrophoresis Systems (Bio-Rad). Purified DNA was microinjected into B6SJLF1/J oocytes at the Transgenic and Molecular Core in Magee-Womens Research Institute. The *Sohlh1* mutant mouse was generated as previously described (Pangas et al., 2006). All experimental and surgical procedures were in compliance with the Guide for the Care and Use of Laboratory Animals and were approved by the University of Pittsburgh IACUC. The *BAC-Sohlh1-mCherryFlag* transgenics will be available upon request to the research community.

Genotyping

Tail DNA was prepared in two ways, depending upon primer sets. For detection of *Sohlh1* wild type (primer G4 and G3, 633bp), targeted allele (primer HPRT2 and G3, 220bp) and

BAC-Sohlh1-mCherryFlag (primer mCherryF1 and S13UR1, 313bp), tails were digested for 1 hour at 100°C in 50mM NaOH followed by neutralization with Tris-HCl (pH8.0, 1M). PCR reactions were performed in 10µl volumes containing 1µl tail DNA, 5µl amfiSure PCR Master Mix (GenDEPOT), 0.25µl each of forward and reverse primers (10uM), and 3.5µl dH₂O. The PCR conditions were 95°C 4min; (95°C 30sec, 60°C 30sec, 72°C 30sec) x 33 cycles; 72°C 5min. For distinguishing *Sohlh1^{+/-}/S1CF* and *Sohlh1^{-/-}/S1CF* (primer G4 and S13UR1, 3.7kb for wild type allele and 4.5kb for *S1CF*), tail DNA was purified using a Genra Puregene Kit (Qiagen). PCR reactions were performed in 20µl volumes containing 25ng of tail DNA, 4µl 5x PrimeSTAR buffer (Takara Bio), 1.6µl 25mM dNTP, 0.5µl each of forward and reverse primers (10uM), 0.2µl PrimeSTAR HS DNA Polymerase (Takara Bio) and 12.2µl dH₂O. The PCR conditions were 98°C 3min; (98°C 10sec, 60°C 5sec, 72°C 5min) x 33 cycles; 72°C 5min. The following primer sequences were used: G3 (3'-CTGGAGCCCAAGAAGACAAG-5'), G4(3'-GTCTTCGGAGAAACGTGGTC-5'), HPRT2, (3'-GCAGTGTGGCTGTATTTTCC-5'), mCherry-F1 (3'-CACCATCGTGGAACAGTACG-5') and S13UR1 (3'-GCCCTGCCAGGCTCCCTCAA-5').

Immunofluorescence and Histology

For all fluorescence analyses, CHERRY was not immunostained with antibody and the original CHERRY signal was observed using confocal laser microscopy; Nikon A1 (Nikon). Male and female gonads were fixed in 4%PFA at 4°C overnight, protected from light. Postnatal ovaries were washed 3 times in PBS containing 0.1% TritonX-100 (0.1%PBS-Tr) for 5 minutes each and incubated with DAPI (PBS containing 0.2 µg/ml DAPI and 50µg/ml RNase) at RT for 2 hours. Ovaries were then washed 3 times in 0.1%PBS-Tr and mounted with ProLong Gold Antifade Reagent (Invitrogen) on a glass slide. Both 3 week old and adult ovaries were sliced by scalpel before being mounted. Embryonic gonads and postnatal testis were also washed 3 times in 0.1%PBS-Tr. After 1.5 hours of blocking with 3%BSA/0.1%PBS-Tr at RT, the tissues were incubated overnight at 4°C with primary antibodies in PBS containing 0.01% TritonX-100 (0.01% PBS-Tr). The following day, the tissues were washed 6 times in 0.01% PBS-Tr for 15 min each and then incubated with secondary antibodies and DAPI for 2 hours at RT. Next, the tissues were again washed 6 times and mounted with ProLong Gold Antifade Reagent (Invitrogen) on a glass slide.

Ovaries and testes were fixed in 4%PFA at 4°C overnight and embedded in paraffin for sectioning. 5µm paraffin sections were deparaffinized and hydrated, and incubated with primary antibodies in 0.1% PBS-Tr at 4°C overnight. Specimens were then washed 3 times in 0.1% PBS-Tr for 5 min each followed by incubation with secondary antibodies and DAPI at RT for 2 hours. After washing 3 times, specimens were mounted with ProLong Gold Antifade Reagent. For histology, sections were stained by Periodic Acid Schiff-Hematoxylin (PAS-H) after hydration and mounted with Cytoseal 60 (Thermo scientific).

Primary antibodies were used at the following dilutions: goat anti-E-Cadherin/CDH1 (R&D systems, AF748) 1:500, goat anti-GFRα1 (R&D systems, AF560) 1:50, rabbit anti-Plzf/ZBTB16 (Santa Cruz, H-300, sc-22839) 1:500, armenian hamster anti-KIT (Yamatani et al., 2004) 1:500, rabbit anti-SOHLH1 (Pangas et al., 2006) 1:500 and mouse anti-FLAG (M2) (Sigma) 1:200. The following secondary antibodies were purchased from Jackson ImmunoResearch Laboratories and were used at a 1:500 dilution: DyLight 594 or 649 donkey anti-goat, 488, 594 or 649 donkey anti-rabbit, 594 goat anti-armenian hamster and 488 donkey anti-mouse.

Culture Spermatogonial Stem/Progenitor Cell

Spermatogonial stem/progenitor cell cultures were established and maintained using two media: F12GFB and SPGF. SPGF consisted of Stem Pro base with 1X Stem Pro supplement (Life Technologies), supplements according to Kanatsu-Shinohara et al. (Kanatsu-Shinohara et al., 2003), recombinant rat glial cell line derived neurotrophic factor (GDNF) at 10 ng/ml (PeproTech), and recombinant human basic fibroblast growth factor (FGF2) at 10 ng/ml (Life Technologies). F12GFB media had a simpler composition than SPGF and consisted of DMEM/F-12 base, GDNF at 10 ng/ml, FGF2 at 10 ng/ml and supplements according to Dann et al. (Dann et al., 2008). Spermatogonia grew as clusters of interconnected cells in both media, however F12GFB medium led to reduced adherence of the clusters to the substratum, compared to SPGF. A feeder layer of irradiated DR4 mouse embryonic fibroblasts (MEFs) was used, as described (Dann et al., 2008; Falciani et al., 2008). Spermatogonial stem/progenitor cell cultures were derived from two PD 21 *Sohlh1^{+/-}/SICF* mice or two non-transgenic siblings (*Sohlh1^{+/-}*). The resulting cell lines were named SOC1 and NEG1, respectively. The procedure for cell line derivation was performed essentially as described, with modifications as follows (Falciani et al., 2008; Kanatsu-Shinohara et al., 2003). Testes were shipped overnight in 1XPBS on ice. The tunica albuginea was removed, seminiferous tubules mechanically dispersed and then enzymatically dissociated in dispase (Becton Biosciences) at 37 °C for 30 minutes. Dissociated cells were strained and plated on a gelatin coated well overnight in SPGF. Non-adherent and loosely bound cells were washed off the well and transferred to MEFs and cultured in F12GFB medium for nine days. During this phase of culture the cells were transferred to new wells of MEFs every 3 days by gentle trituration to separate spermatogonia from adhering somatic cells. In F12GFB medium the spermatogonial clusters grew in suspension or loosely bound to the substratum, while somatic cells adhered to the plate. For subsequent culturing the cells were maintained in SPGF medium on MEFs and passaged by dissociating with 0.05% trypsin (Hyclone) (Falciani et al., 2008). Images of spermatogonial stem/progenitor clusters were acquired using a BD Biosciences Pathway 435 High-Content Bioimager with a Lumenera-Infinity 3-1 cooled CCD camera and a 20X (U Apo/340 0.75 NA, Olympus) objective. Where indicated, spermatogonial stem/progenitor cells were plated without MEFs on laminin coated wells (0.016 mg/mL; Sigma) for one day prior to imaging.

Co-immunoprecipitation analysis

4 testes from PD7 *Sohlh1^{+/-}* and *Sohlh1^{+/-}/SICF* pups were used for immunoprecipitation by anti-FLAG M2 Magnetic Beads (Sigma), as described previously (Suzuki et al., 2012).

Acknowledgments

We would like to thank Allison Metz for general assistance. This study was supported by R01HD056351 and March of Dimes grant #6-FY08-313 (to A.R.)

References

- Baibakov B, Gauthier L, Talbot P, Rankin TL, Dean J. Sperm binding to the zona pellucida is not sufficient to induce acrosome exocytosis. *Development*. 2007; 134:933–43. [PubMed: 17293534]
- Ballow D, Meistrich ML, Matzuk M, Rajkovic A. *Sohlh1* is essential for spermatogonial differentiation. *Developmental biology*. 2006; 294:161–7. [PubMed: 16564520]
- Dann CT, Alvarado AL, Molyneux LA, Denard BS, Garbers DL, Porteus MH. Spermatogonial stem cell self-renewal requires OCT4, a factor downregulated during retinoic acid-induced differentiation. *Stem Cells*. 2008; 26:2928–37. [PubMed: 18719224]
- Falciani I, Lillard-Wetherell K, Wu Z, Hamra FK, Garbers DL. Deriving mouse spermatogonial stem cell lines. *Methods Mol Biol*. 2008; 450:181–92. [PubMed: 18370060]

- Hoodbhoy T, Aviles M, Baibakov B, Epifano O, Jimenez-Movilla M, Gauthier L, Dean J. ZP2 and ZP3 traffic independently within oocytes prior to assembly into the extracellular zona pellucida. *Molecular and cellular biology*. 2006; 26:7991–8. [PubMed: 17047254]
- Kanatsu-Shinohara M, Ogonuki N, Inoue K, Miki H, Ogura A, Toyokuni S, Shinohara T. Long-term proliferation in culture and germline transmission of mouse male germline stem cells. *Biol Reprod*. 2003; 69:612–6. [PubMed: 12700182]
- Molyneaux KA, Stallock J, Schaible K, Wylie C. Time-lapse analysis of living mouse germ cell migration. *Developmental biology*. 2001; 240:488–98. [PubMed: 11784078]
- Molyneaux KA, Zinszner H, Kunwar PS, Schaible K, Stebler J, Sunshine MJ, O'Brien W, Raz E, Littman D, Wylie C, Lehmann R. The chemokine SDF1/CXCL12 and its receptor CXCR4 regulate mouse germ cell migration and survival. *Development*. 2003; 130:4279–86. [PubMed: 12900445]
- Pangas SA, Choi Y, Ballow DJ, Zhao Y, Westphal H, Matzuk MM, Rajkovic A. Oogenesis requires germ cell-specific transcriptional regulators *Sohlh1* and *Lhx8*. *Proceedings of the National Academy of Sciences of the United States of America*. 2006; 103:8090–5. [PubMed: 16690745]
- Philpott CC, Ringuette MJ, Dean J. Oocyte-specific expression and developmental regulation of ZP3, the sperm receptor of the mouse zona pellucida. *Developmental biology*. 1987; 121:568–75. [PubMed: 2884155]
- Runyan C, Schaible K, Molyneaux K, Wang Z, Levin L, Wylie C. Steel factor controls midline cell death of primordial germ cells and is essential for their normal proliferation and migration. *Development*. 2006; 133:4861–9. [PubMed: 17107997]
- Suzuki H, Ahn HW, Chu T, Bowden W, Gassei K, Orwig K, Rajkovic A. *SOHLH1* and *SOHLH2* coordinate spermatogonial differentiation. *Developmental biology*. 2012; 361:301–12. [PubMed: 22056784]
- Takeuchi Y, Molyneaux K, Runyan C, Schaible K, Wylie C. The roles of FGF signaling in germ cell migration in the mouse. *Development*. 2005; 132:5399–409. [PubMed: 16291796]
- Warming S, Costantino N, Court DL, Jenkins NA, Copeland NG. Simple and highly efficient BAC recombineering using galK selection. *Nucleic acids research*. 2005; 33:e36. [PubMed: 15731329]
- Yamatani H, Sato Y, Fujisawa H, Hirata T. Chronotopic organization of olfactory bulb axons in the lateral olfactory tract. *The Journal of comparative neurology*. 2004; 475:247–60. [PubMed: 15211465]
- Yan C, Elvin JA, Lin YN, Hadsell LA, Wang J, DeMayo FJ, Matzuk MM. Regulation of growth differentiation factor 9 expression in oocytes in vivo: a key role of the E-box. *Biology of reproduction*. 2006; 74:999–1006. [PubMed: 16495478]
- Yoshida S, Sukeno M, Nabeshima Y. A vasculature-associated niche for undifferentiated spermatogonia in the mouse testis. *Science*. 2007; 317:1722–6. [PubMed: 17823316]

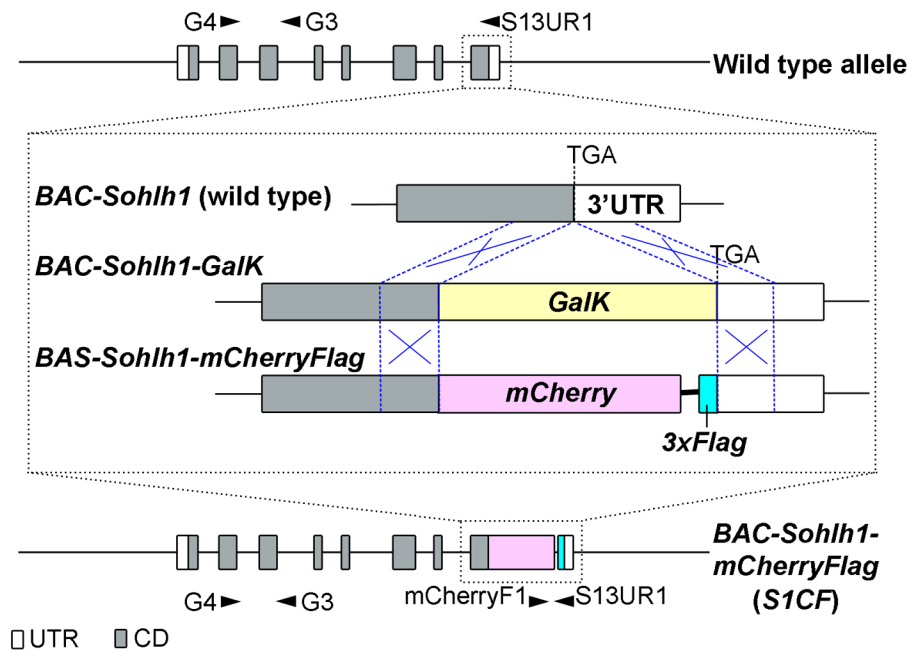

Figure 1. BAC-Sohlh1-mCherryFlag engineering

(A) *BAC-Sohlh1-mCherryFlag (S1CF)* construction. For *BAC-Sohlh1-mCherryFlag (S1CF)* engineering, the *GalK* sequence (yellow box) was first inserted just before the stop codon on the *Sohlh1* exon 8, using a homologous recombination system in bacteria, followed by the replacement of *mCherry-3xFlag* (Magenta and turquoise boxes). Homologous regions used for recombination are indicated in blue break lines. PCR primer locations are shown with black arrowheads. Gray boxes represent the *Sohlh1* coding region (CD) and white boxes represent the untranslated region (UTR). The following primer sets were used for PCR: G4 and G3 for wild type (633bp), mCherryF1 and S13UR1 for *S1CF* (313bp). In matings with the *Sohlh1*^{+/-}, we also used HPRT2 and G3 primers previously described to detect the mutant allele (220bp) (Pangas et al., 2006).

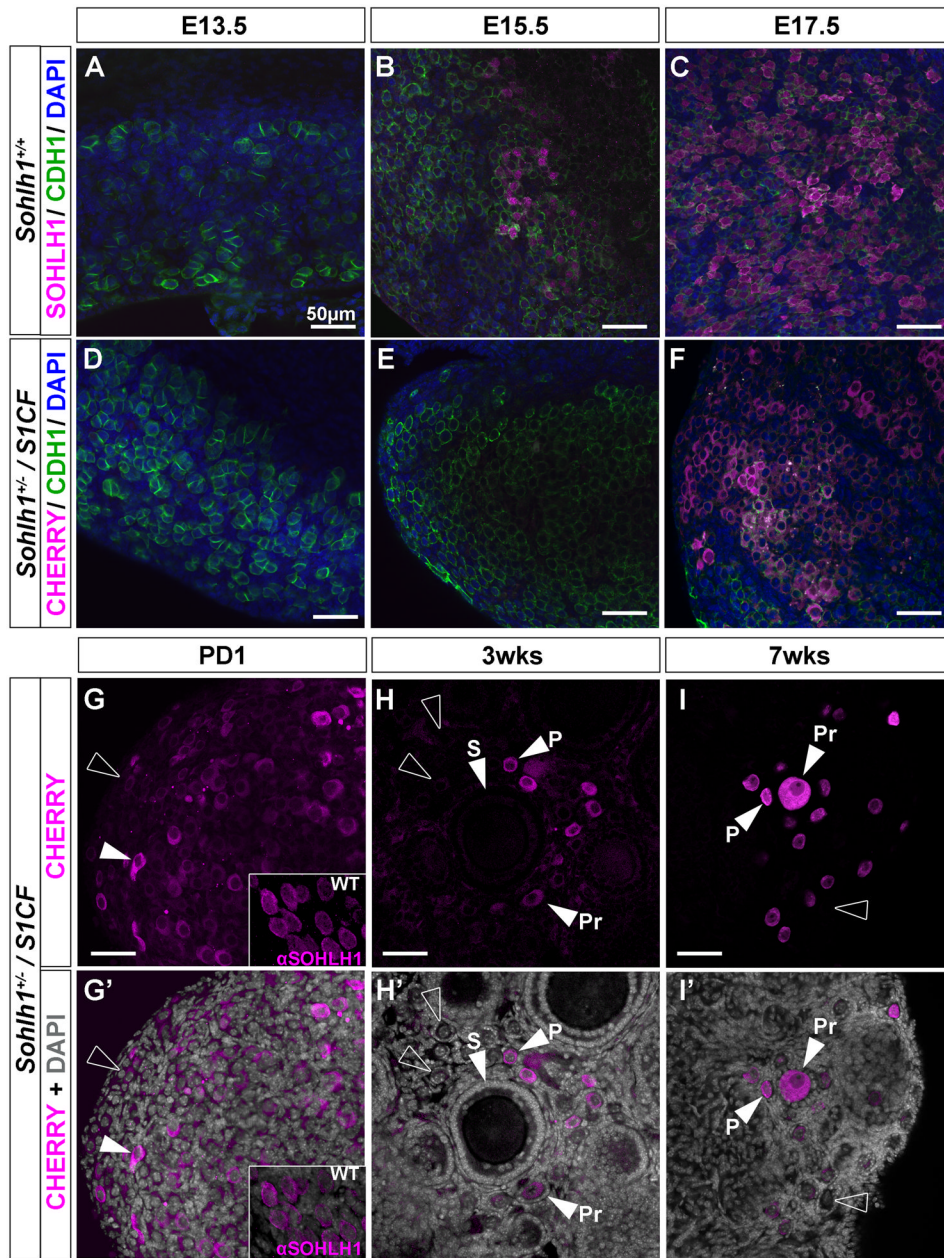

Figure 2. CHERRY expression mimics endogenous SOHLH1 expression in female gonads
 Endogenous SOHLH1 (A–C) and CHERRY (D–I) expression in female gonads at E13.5 (A and D), E15.5 (B and E), E17.5 (C and F), postnatal 1 day (PD1; G and G'), 3 weeks old (H and H') and 7 weeks old (I and I'). (A–F) Gonads were immunostained with anti-CDH1 (green) (A–F) and anti-SOHLH1 (magenta) (A–C), and counter stained with DAPI (blue). Native CHERRY fluorescence is shown in magenta. Genotypes are indicated. (G–I) Ovaries were counter stained with DAPI (gray in G'–I'). Native CHERRY fluorescence is shown in magenta (not immunostained). The endogenous SOHLH1 localization in wild type PD1 ovary is shown in insets of G and G'. P, primordial follicle; Pr, primary follicle; S, secondary follicle. White arrowheads indicate oocytes expressing CHERRY and open arrowheads indicate oocytes that do not express CHERRY. Scale bars represent 50 μ m. Endogenous SOHLH1 expression commences between E14.5–15.5 in a subset of germ cells

and expands to all germ cells by the time of birth. Endogenous SOHLH1 protein can be detected in germ cell cysts, primordial follicles and primary follicles but not in secondary follicles. Endogenous SOHLH1 was dominantly localized to the cytoplasm in most oocytes. CHERRY mimics endogenous SOHLH1 expression and developmental localization, however, the onset of CHERRY expression was slightly later than that of endogenous SOHLH1. We did not observe this delay when CHERRY was expressed on the background of *Sohlh1* deficient gonads, arguing that some negative regulation by endogenous SOHLH1 may exist.

\$watermark-text

\$watermark-text

\$watermark-text

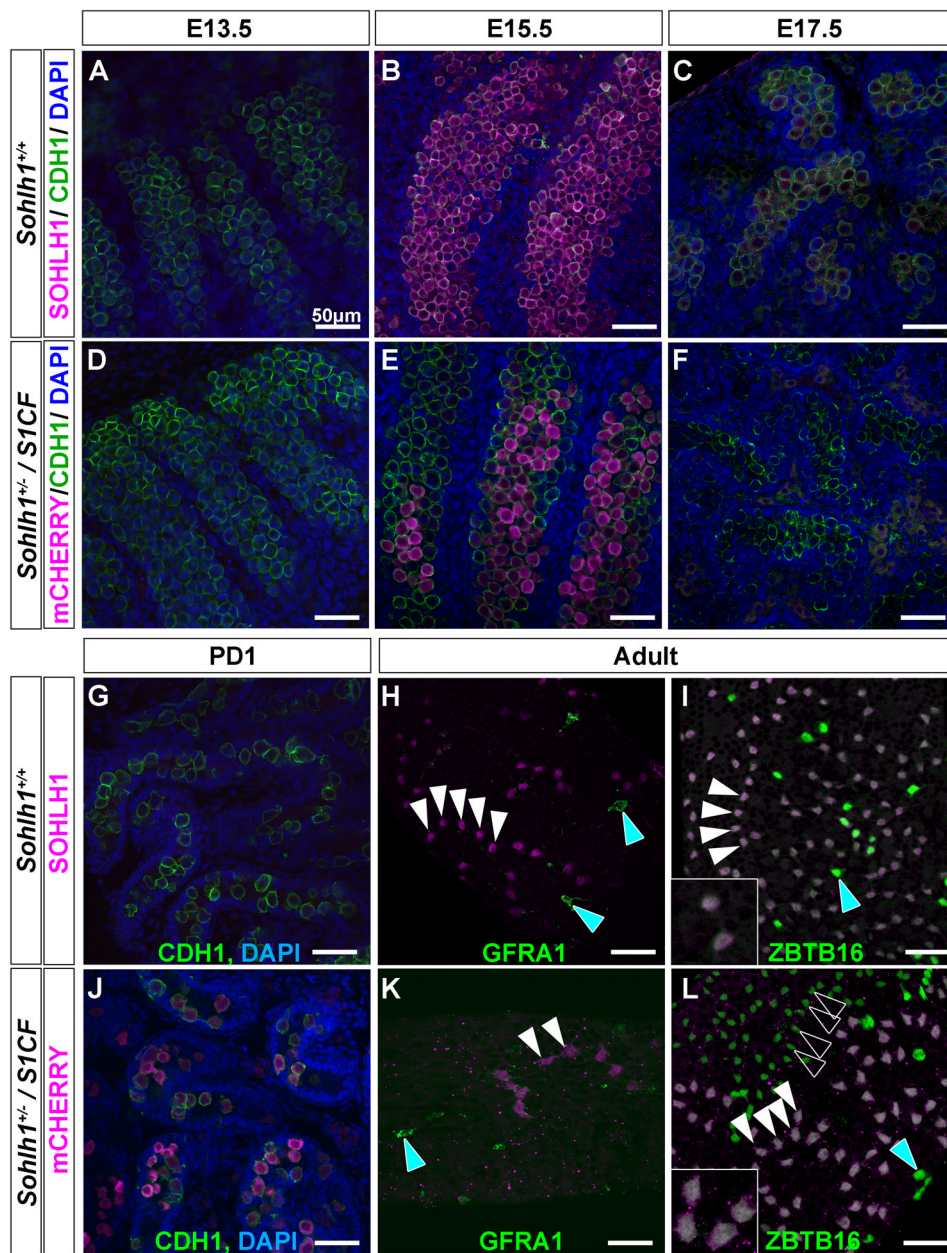

Figure 3. CHERRY expression mimics endogenous SOHLH1 expression in male gonads
 SOHLH1 (A–C and G–I) and CHERRY (D–F and J–L) expression in male gonads at E13.5 (A and D), E15.5 (B and E), E17.5 (C and F), PD1 (PD1; G and J) and 8 weeks old adult (H, I, K and L). Gonads were immunostained with anti-CDH1 (green) (A–G and J), anti-SOHLH1 (magenta) (D–F and G–I), anti-GFRA1 (green) (H and K) and ZBTB16 (green) (I and L), and counter stained with DAPI (blue) (A–G and J). Genotypes are indicated. CHERRY signals are shown in magenta (D–F and J–L). Cyan arrowheads indicate GFRA1-positive or ZBTB16 positive A_s undifferentiating spermatogonia that do not express SOHLH1 or CHERRY. White arrowheads indicate SOHLH1 or CHERRY positive spermatogonia. Open arrowheads indicate CHERRY negative differentiating spermatogonia that would be expected to express SOHLH1. Scale bars represent 50µm. Endogenous SOHLH1 expression commences at around E15.5 and decreases in the perinatal testis until

PD3, when SOHLH1 can be detected again in spermatogonia. Endogenous SOHLH1 protein was detected in both undifferentiated (H) and differentiating (I) spermatogonia, but was not observed in most of the GFRA1-positive undifferentiated spermatogonial population. CHERRY closely mimics this endogenous SOHLH1 expression throughout the development of male germ cells.

\$watermark-text

\$watermark-text

\$watermark-text

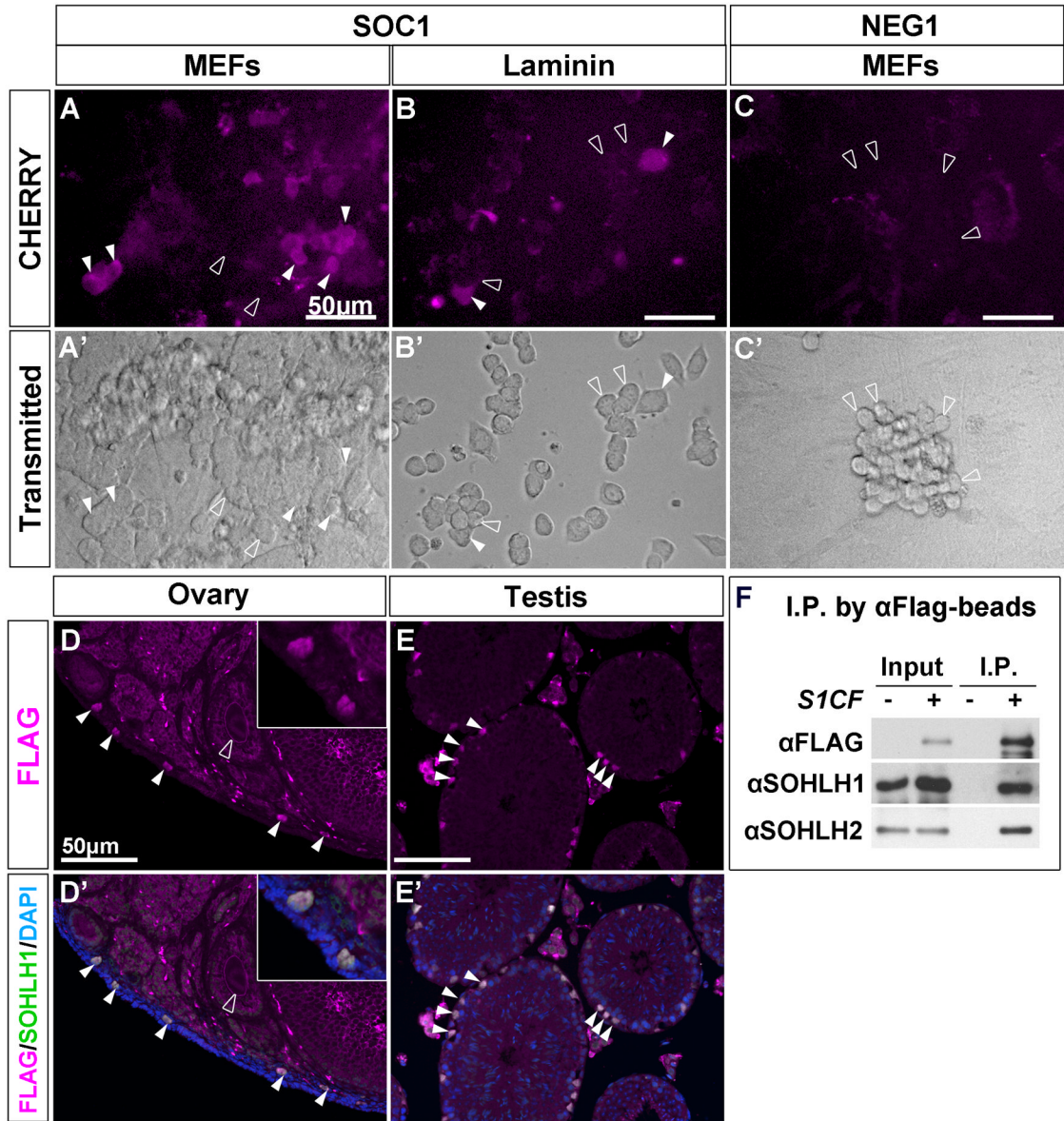

Figure 4. *S1CF* is useful for multiple analysis

(A–C) Spermatogonial stem/progenitor cells derived from *Sohlh1*^{+/-}/*S1CF* (SOC1; A, B) or *Sohlh1*^{+/-} (NEG1; C) were cultured on MEFs (A, C) or laminin (B). On MEFs the cultured cells proliferated to form large 3-dimensional clusters of interconnected cells while on laminin the cultured cells exhibited a flatter morphology. CHERRY fluorescence was observed in a subset of the SOC1 spermatogonial population (A, B) but not in NEG1 (C). White arrowheads indicate spermatogonia expressing CHERRY and open arrowheads indicate spermatogonia that do not express CHERRY. Scale bars represent 50μm. (D and E) Section immunofluorescence of adult ovary (D) and testis (E) harboring the *S1CF* transgene. Specimens were immunostained with anti-SOHLH1 (green) and anti-FLAG (magenta), and counter stained with DAPI (blue). White arrowheads indicate oocytes or spermatogonia stained with SOHLH1 and FLAG. The open arrowhead in A, A' and A'' indicates an oocyte in the secondary follicle stage that expresses neither SOHLH1 nor FLAG. Scale bars represent 50μm. (F) Immunoprecipitation–Western blot analyses of proteins from PD7

testes extracts of wild type and *S1CF* transgenic mice using anti-FLAG antibody conjugated beads. Each antibody used for western blot analysis is indicated at the left side of panel. Input: pre-immunoprecipitation testes lysate (1%). S1CF was immunoprecipitated only from S1CF-positive lysate (I.P.). Endogenous SOHLH1 and SOHLH2 were co-immunoprecipitated with S1CF, indicating that SOHLH1 homodimerizes and heterodimerizes *in vivo* in the testis.

\$watermark-text

\$watermark-text

\$watermark-text

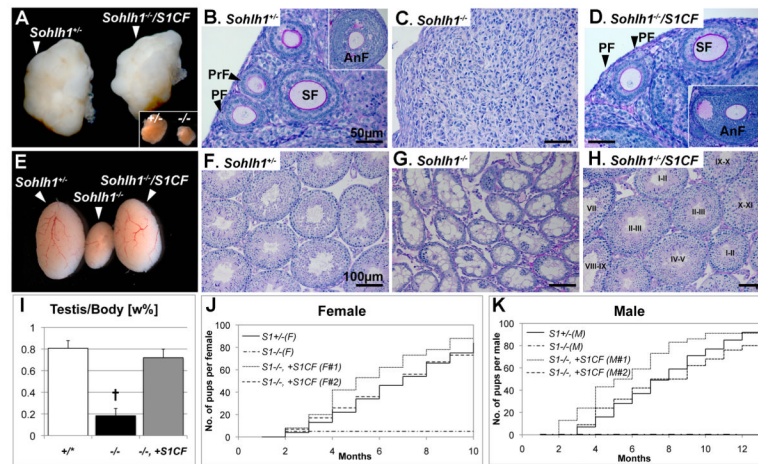

Figure 5. *SICF* transgene rescues the *Sohlh1*^{-/-} phenotype in both males and females *Sohlh1*^{-/-}/*SICF* adult anatomy, histology, and cumulative number of pups from females (A–D and J) and males (E–I and K). (A) Ovaries shown under the same magnification for *Sohlh1*^{+/*} (left), and knockout rescued by *SICF*, *Sohlh1*^{-/-}/*SICF* (right). Inset in the right lower corner shows that *Sohlh1*^{-/-} (–/–) ovaries are one third the size of wild type or *Sohlh1*^{+/*} (+/*) ovaries as previously reported (Pangas et al., 2006). (B–D) PAS-Hematoxylin staining of adult ovaries. Various stages of follicular development are shown, primordial (PF), primary (PrF), secondary (SF) and antral (AnF) follicles, in *Sohlh1*^{+/*} (B) and *Sohlh1*^{-/-}/*SICF* (D) ovaries but no follicles are visible in *Sohlh1*^{-/-} at the same age (C). Scale bars represent 50 μ m. (E) Gross testes dissected from *Sohlh1*^{+/*} (left), *Sohlh1*^{-/-} (middle) and *Sohlh1*^{-/-}/*SICF* (right) mice. *Sohlh1*^{-/-} testis size was recovered in the presence of *SICF* and was equivalent to *Sohlh1*^{+/*} testes. (F–H) PAS staining of adult testes. Various epithelial stages of seminiferous tubules were observed in *Sohlh1*^{+/*} (F) and *Sohlh1*^{-/-}/*SICF* (H) testis but not in *Sohlh1*^{-/-} testis at the same age (G). Scale bars represent 100 μ m. (I) Comparison of testes weights. *Sohlh1*^{-/-} (–/–) testes weights recovered with *SICF* (–/–, +*SICF*), similarly as in *Sohlh1*^{+/*} (+/*) (*Sohlh1*^{+/*} or *Sohlh1*^{+/*}) ($P < 0.1$). More than 3 mice were examined for each genotype. Error bars show SE. Student t-test was used to calculate P values. †, $P < 0.01$ against wild type. (J and K) Comparison of the cumulative number of pups per female (J) or male (K). Genotypes for each line are indicated in the figure. (J) *Sohlh1*^{-/-} females are infertile, except for occasional, one-time litter observed among a subset of females prior to 8 weeks of age, but *Sohlh1*^{-/-}/*SICF* (n=3) fertility was comparable to *Sohlh1*^{+/*} females. (K) *Sohlh1*^{-/-} males were infertile and did not yield any pups, but *Sohlh1*^{-/-}/*SICF* (n=8) males fertility was comparable to *Sohlh1*^{+/*} males.