

Lawrence Berkeley National Laboratory

Lawrence Berkeley National Laboratory

Title

TMVOC, simulator for multiple volatile organic chemicals

Permalink

<https://escholarship.org/uc/item/1qk9542v>

Authors

Pruess, Karsten
Battistelli, Alfredo

Publication Date

2003-03-25

TMVOC, A SIMULATOR FOR MULTIPLE VOLATILE ORGANIC CHEMICALS

Karsten Pruess¹ and Alfredo Battistelli²

¹ Earth Sciences Division, Lawrence Berkeley National Laboratory, Berkeley, CA 94720

² Aquater S.p.A., 61047 San Lorenzo in Campo (PU), Italy

e-mail: K_Pruess@lbl.gov

ABSTRACT

TMVOC is a numerical simulator for three-phase non-isothermal flow of water, soil gas, and a multicomponent mixture of volatile organic chemicals (VOCs) in multidimensional heterogeneous porous media. It is an extension of the TOUGH2 general-purpose simulation program developed at the Lawrence Berkeley National Laboratory. TMVOC is designed for applications to contamination problems that involve hydrocarbon fuel or organic solvent spills in saturated and unsaturated zones. It can model contaminant behavior under “natural” environmental conditions, as well as for engineered systems, such as soil vapor extraction, groundwater pumping, or steam-assisted source remediation. TMVOC is upwards compatible with T2VOC (Falta et al., 1995) and can be initialized from T2VOC-style initial conditions.

The main enhancements in TMVOC relative to T2VOC are as follows:

- a multicomponent mixture of volatile organic chemicals can be modeled;
- any and all combinations of the three phases water - oil - gas are treated;
- several non-condensable gases may be present;
- diffusion is treated in all phases in a manner that is fully coupled with phase partitioning.

This paper gives a brief summary of the methodology used in TMVOC as well as highlighting some implementation issues. Simulation of a NAPL spill and subsequent remediation is discussed for a 2-D vertical section of a saturated-unsaturated flow problem.

INTRODUCTION

Many environmental contamination problems involve volatile organic chemicals (VOCs), such as crude oil, gasoline or diesel, and organic solvents. When spilled into the unsaturated zone, these chemicals may form a separate non-aqueous phase, giving rise to three-phase flow of water, soil gas, and a non-aqueous phase liquid (NAPL). Such flows can be modeled with T2VOC, but that code is limited to conditions where the VOC is a pure, single-component fluid. However,

in many cases of interest non-aqueous fluids released into the subsurface may consist of a multicomponent mixture of several different chemicals. TMVOC is designed for three-phase flows in which the NAPL consists of a general multi-component mixture of organic fluids. In addition one or several non-condensable gases may be present.

TMVOC is based on the M2NOTS code that was developed by Adenekan (1992) as part of his PhD project at the University of California, Berkeley. It is implemented as a specialized module in the framework of the general multi-purpose simulator TOUGH2 (Pruess et al., 1999), retains its general process modeling capabilities and user features, and is upwardly compatible with T2VOC. T2VOC input files may be executed with TMVOC with slight modifications. TMVOC is available from DOE's Energy Science and Technology Software Center (ESTSC; <http://www.osti.gov/estsc/>).

This paper presents an overview of TMVOC, including the formulations used for fluid properties, and issues of implementation in the general TOUGH2 structure. We also demonstrate an application to an unsaturated zone contamination problem. More detailed information is available in the user's guide (Pruess and Battistelli, 2002).

PHYSICAL PROCESSES AND ASSUMPTIONS

In the TMVOC formulation, the multiphase system is assumed to be composed of water, non-condensable gases (NCGs), and water-soluble volatile organic chemicals (VOCs). The number and nature of NCGs and VOCs can be specified by the user. Organic chemicals with critical temperatures below ambient, such as methane or ethane, can be modeled as NCGs. There are no intrinsic limitations to the number of NCGs or VOCs. Thermophysical property data for individual VOCs must be provided by the user. TMVOC uses a very general formulation to obtain thermophysical and PVT (pressure-volume-temperature) properties for mixtures of VOCs and NCGs. The fluid components may partition (volatilize and/or dissolve) among gas, aqueous, and NAPL phases. Any combination of the three phases

may be present (Fig. 1), and phases may appear and disappear in the course of a simulation.

Flows can be non-isothermal, and may involve advective, diffusive, phase-partitioning, and sorptive processes. A simple model for biodegradation is provided as well. Chief applications for which TMVOC is designed include analysis of NAPL spills and remediation alternatives in the vadose zone and below the water table.

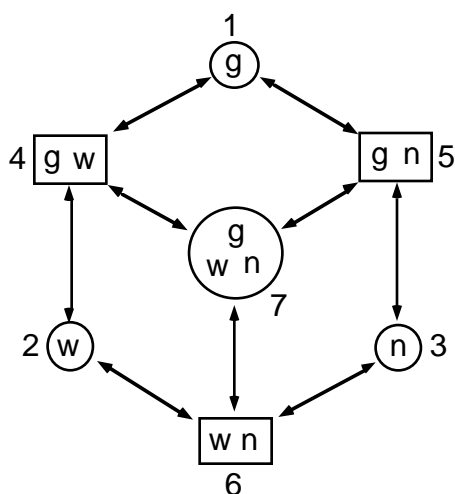

Figure 1. Phase compositions and phase changes considered by TMVOC. The phase designations are: g - gas, w - water (aqueous), n - NAPL.

Each phase flows in response to pressure and gravitational forces according to a multiphase extension of Darcy's law, which includes effects of relative permeability and capillary pressure between the phases. Transport of the mass components may also occur by molecular diffusion in all phases. Multiphase diffusion is treated in a fully-coupled manner that can cope with diffusion of phase-partitioning components under conditions of variable phase saturations. No Fickian model for hydrodynamic dispersion is implemented at the present time. In heterogeneous media dispersion is often caused by mass exchanges between pore regions with different fluid mobilities (Coats and Smith, 1964; Harvey and Gorelick, 2000), and such effects can be modeled with TMVOC using the method of "multiple interacting continua" (MINC; Pruess and Narasimhan, 1985).

It is assumed that the three phases are in local chemical and thermal equilibrium, and that no chemical reactions are taking place other than (a) interphase mass transfer, (b) adsorption of chemical components to the solid phase, and (c) decay of VOCs by biodegradation. Mechanisms of interphase mass transfer for the organic chemicals include evaporation

and boiling, dissolution into the aqueous phase, condensation of organic chemicals from the gas phase into a NAPL, and equilibrium phase partitioning of organic chemicals between the gas, aqueous, and solid phases. Interphase mass transfer of the water component includes the effects of evaporation and boiling of the aqueous phase, condensation of water vapor from the gas phase, and water dissolution into the NAPL phase. The interphase mass transfer of the non-condensable gas components consists of equilibrium phase partitioning between the gas, aqueous, and NAPL phases.

Heat transfer occurs due to conduction and multiphase convection; heat flow associated with diffusive fluxes is neglected. The heat transfer effects of phase transitions between the NAPL, aqueous and gas phases are fully accounted for by considering the transport of both latent and sensible heat. However, heat of dissolution effects for NCG dissolution in NAPL and aqueous phases and for water in the NAPL are neglected, as are heat effects associated with adsorption/desorption of VOCs. The overall porous medium thermal conductivity is calculated as a function of total liquid saturation (water and NAPL).

Vapor pressure lowering effects due to capillary forces are not presently included in the simulator. The solubility of the organic chemical in water may be specified as a function of temperature, and Henry's coefficient for dissolution of organic chemical vapors in the aqueous phase is calculated as a function of temperature. The Henry's coefficients for NCG dissolution in the aqueous phase are calculated as functions of temperature, whereas Henry's coefficients for NCG dissolution in NAPL have for simplicity been assumed to be constant. Water solubility in a generic NAPL is computed as a function of temperature.

The necessary NAPL/organic chemical and transport properties are computed by means of a very general thermodynamic formulation, which uses semi-empirical corresponding states methods in which chemical parameters are calculated as functions of the critical properties of the chemical such as the critical temperature and pressure. Because these data are available for hundreds of organic compounds (Reid et al., 1987), the NAPL/organic chemical equation of state is quite flexible in its application. The gas phase is treated as a mixture of "real" (not ideal) gases.

Porosity may change as a function of fluid pressure and temperature, using simple concepts of pore compressibility and expansivity. No stress calculations are made in TMVOC.

FLUID PROPERTIES

The fluid description in TMVOC includes arbitrary multiphase mixtures of $\kappa = 1, \dots, NK$ mass components, including water ($\kappa = 1$), NCG non-condensable gases ($\kappa = 2, 3, \dots, 1+NCG$), and NHC user-selected VOCs ($\kappa = 1+NCG+1, 1+NCG+2, \dots, 1+NCG+NHC = NK$), which we often refer to as “hydrocarbons.” The NK fluid components may be distributed in any combination of one, two, or three phases, namely, $\beta = 1$: gas, a multi-component mixture of NCGs, water vapor, and hydrocarbon vapors; $\beta = 2$: aqueous, which for convenience is often referred to as “water,” and may include dissolved hydrocarbons and NCGs in addition to water substance; and $\beta = 3$: oil or NAPL phase, whose primary constituents are the NHC hydrocarbon components, but which may contain both dissolved water and NCGs.

The individual fluid components partition among different phases in such a way that their chemical potentials are the same in all phases (Prausnitz et al., 1986). TMVOC assumes ideal mixtures, with all fugacity and activity coefficients equal to one. Partitioning of components among phases can then be written in terms of mole fraction ratios being equal to equilibrium constants, such as

$$\frac{x_w^{\kappa}}{x_n^{\kappa}} = K_{wn}^{\kappa}; \quad \frac{x_w^{\kappa}}{x_g^{\kappa}} = K_{wg}^{\kappa}; \quad \frac{x_n^{\kappa}}{x_g^{\kappa}} = K_{ng}^{\kappa} \quad (1)$$

Equilibrium constants for the condensible fluid components (VOCs, water) can be expressed in terms of solubilities and vapor pressures, so that for gas-liquid phase partitioning Eq. (1) reduces to Henry’s law.

Gas Phase. At ambient conditions, the main constituent of the gas phase will be air. TMVOC can represent air as a single pseudo-component, or as a mixture of N_2 and O_2 . Other non-condensable gases may also be included. VOC vapors will be present in concentrations that depend upon VOC concentrations in the aqueous phase (or the NAPL phase, if it exists), and upon the VOC vapor pressures which depend strongly on temperature. Water vapor may be present at partial pressures up to saturated values for the given temperature. PVT properties of the gas phase are usually described with the Soave-Redlich-Kwong (SRK) equation of state (Redlich and Kwong, 1949; Soave, 1972). This is a cubic equation which is commonly used for petroleum reservoir fluids and other nonpolar organic substances. For a pure component the SRK equation may be written in the form

$$Z^3 - Z^2 + (A^* - B^* - (B^*)^2)Z - A^*B^* = 0 \quad (2)$$

where the largest root Z is the real gas compressibility factor, and $A^* = aP/R^2T^2$ and $B^* = bP/RT$ are parameters that depend on pressure P and absolute temperature T , with R the universal gas constant. Parameters a and b and the mixing rules to compute their multicomponent expressions are given by Reid et al. (1987). Optionally a version of the SRK equation with modified coefficients or the Peng-Robinson (PR) equation (Peng and Robinson, 1976) may be used. For the calculation of gas phase viscosities and thermal parameters, the reader is referred to the TMVOC user’s guide (Pruess and Battistelli, 2002).

Aqueous Phase. The dominant constituent of the aqueous phase is water. VOCs may be present in concentrations that depend on temperature-dependent solubilities, and on VOC concentrations in gas or oil phases, if present. The saturation pressure, density and internal energy of water are computed, within experimental accuracy, using the International Formulation Committee correlations (IFC, 1967) implemented in the TOUGH2 code. Dynamic viscosity of liquid water and steam is calculated using the correlation proposed by the International Association for the Properties of Steam (IAPS; Meyer et al., 1977).

The solubility of VOCs in the aqueous phase is usually small, and it may appear that the presence of small amounts of dissolved VOCs would have negligible impact on aqueous phase density. However, a closer examination of the issues revealed that neglecting the impact of dissolved VOC on the aqueous phase density may result in unacceptably large spurious pressure excursions. Accordingly, density of the aqueous phase is allowed to vary with dissolved VOC concentrations. The model implemented in TMVOC assumes that upon NAPL dissolution in water the total fluid volume (water plus NAPL) is conserved.

Adsorption of VOCs on solid grains is assumed to occur through the aqueous phase and is described with a linear adsorption isotherm. VOC dissolved in the aqueous phase may also biodegrade according to a simple half-life model.

NAPL Phase. This phase consists primarily of condensed VOCs, with usually small admixtures of dissolved water and NCGs. Thermophysical properties of the NAPL phase, such as saturated vapor pressure, viscosity, and specific enthalpy are calculated as functions of temperature and composition, while density is computed as function of temperature, composition, and pressure, using standard correlations

developed in petroleum engineering (Reid et al., 1987). For purposes of calculating density, the NAPL phase is assumed to be an ideal mixture of the VOC components; effects of the small solubilities of water and NCG on NAPL density are neglected.

IMPLEMENTATION ISSUES

TMVOC operates within the framework of TOUGH2, Version 2.0 (Pruess et al., 1999), but it has a number of special features. In most TOUGH2 modules different phase compositions are distinguished by means of distinctive numerical ranges of the primary thermodynamic variables. For example, the EOS3 fluid property module for water-air mixtures uses the primary variables (P, X, T) (= pressure, air mass fraction, temperature) in single-phase conditions, while in two-phase conditions the second primary variable is $X_2 = S_g + 10$ (= gas saturation plus 10). X_2 being either between zero and one, or between ten and eleven, serves as a flag to distinguish single-phase and two-phase conditions. A scheme of recognizing phase conditions from the numerical values of primary variables is very convenient for systems in which at most two fluid phases can be present, but it becomes awkward for systems with three or more phases. In that case it is much more convenient to use a numerical index to distinguish different phase compositions (Adenekan et al., 1993; Pruess and Battistelli, 2002), and this is the approach adopted in TMVOC.

The particular indices attached to the different possible phase combinations are shown in Fig. 1. Use of an integer index to label phase compositions requires small adjustments in input formats for the primary variables. If during a simulation it is found that a fluid phase either appears or disappears, the phase index is changed according to the labeling shown in Fig. 1. Primary variables are different for different phase compositions, and are switched during phase (dis-)appearance. Mole fractions may change dramatically during phase appearance; for example, when a NAPL phase evolves from VOCs that are either dissolved in the aqueous phase or volatilized in the gas phase, mole fractions of different VOCs in the water or gas phase may be quite differently affected, due to different solubility and vapor pressure constraints. The progress of the simulation with new phase composition can depend sensitively on the initialization of VOC mole fractions. Ideally the new phase compositions should be obtained by equilibrating a multicomponent mixture of known overall composition among the fluid phases present. This requires what in the chemical engineering literature is known as a “flash calculation.” TMVOC uses this approach when a NAPL phase evolves from either single-phase gas or two-phase gas-water conditions. For other phase transitions a simpler

approach is used, in which newly appearing phases are initialized with a small saturation (10^{-6}) so that their impact on the composition of the other phases is small.

The governing mass and energy balance equations have the same form whether mass- or mole-based quantities are used. The modules released as TOUGH2, Version 2.0 all use mass-based quantities internally; for example, fluid density is expressed as mass per unit volume, kg/m^3 . TMVOC follows the original M2NOTS code and performs all calculations using molar quantities internally; for example, fluid density is expressed as (gram-)moles per unit volume, moles/m^3 . This has some advantages for treating fluid properties. However, production and injection specifications are made in standard mass-based metric units, and some quantities are internally converted to mass units before being printed in the output file. The gravity body force term in Darcy's law involves the mass density, and an internal conversion from molar densities is performed for this.

SAMPLE PROBLEMS

The TMVOC user's guide (Pruess and Battistelli, 2002) includes a number of sample problems (Table 1), which can serve as benchmarks for proper code installation. They can also serve as a tutorial for TMVOC applications, as well as providing templates to facilitate preparation of input data for new flow problems.

NAPL Spill in the Unsaturated Zone

This problem involves a two-dimensional vertical section of 1 m thickness that is oriented parallel to the direction of flow in the aquifer. The section is 100 m long and extends from the land surface to a depth of 15 m (Fig. 2). Depth to water table is 5 m on the left side of the section and 5.5 m on the right side, resulting in flow from left to right in the aquifer with a pore velocity of 18.9 m/yr. A 2-D Cartesian grid is used, consisting of 40 columns and 17 layers for a total of 680 elements. The problem is run in four segments, (1) generation of steady flow prior to introduction of NAPL, (2) NAPL spill in the unsaturated zone, (3) redistribution of NAPL, and (4) extraction simultaneously in the saturated and unsaturated zones. The preparation of input data for the steady state equilibration run of the 2-D grid consisted of the following steps:

- generation of the 2-D grid using the MESHMAKER facility for Cartesian grids available within TMVOC. Small changes were made in subroutine GXYZ of the MESHMAKER module meshm.f to obtain the domain assignments as shown in Fig. 2.
- generation of left side boundary conditions using column 1 of the 2-D grid and running to

gravity-capillary equilibrium. For this, atmospheric conditions were assigned to the topmost element, and single-phase water conditions with an appropriate pressure were assigned to the first element in the saturated zone in order to fix the water table elevation. The pressure-controlling grid blocks were made inactive for this run.

- generation of right side boundary conditions using column 40 of the 2-D grid, following

the same procedure as described for the left boundary.

The runs prior to the NAPL spill involve only two components, water and air. They were performed with NK=2 and without any VOC data. The numerically most difficult aspect of generating the initial (“natural”) state prior to the contamination event is that, because of different water table elevations at the left and right boundaries, some grid blocks in grid layer C are very close to the phase boundary.

Table 1. TMVOC Sample Problems

Problem	Title	Comments
1	Demonstrating Initialization of Different Phase Conditions	document initialization of all possible phase conditions
2	1-D Buckley-Leverett Flow	adaptation of a T2VOC sample problem; results agree closely with T2VOC (#)
3	Diffusion	simultaneous diffusion of several solutes in single-phase water, along with thermal diffusion
4	Steam Displacement of a NAPL in a Laboratory Column	injection, waterflooding, and steamflooding of TCE in a horizontal 1-D column; adapted from a T2VOC sample problem
5	Steam Displacement of a Benzene-Toluene Mixture in a Laboratory Column	variation of Problem 4, using a two-component mixture of benzene and toluene instead of TCE
6	Air Displacement of a NAPL from a Laboratory Column	gas-NAPL problem (no water) adapted from Ho (1995)
7	NAPL Spill in the Unsaturated Zone	multi-component NAPL spill and remediation in a 2-D section model with realistic features

(#) When run on the same problem, TMVOC results may show some differences in comparison to T2VOC. This is due to the use of different primary variables, which may affect the iteration sequence and time stepping, and also due to slight differences in thermophysical property correlations.

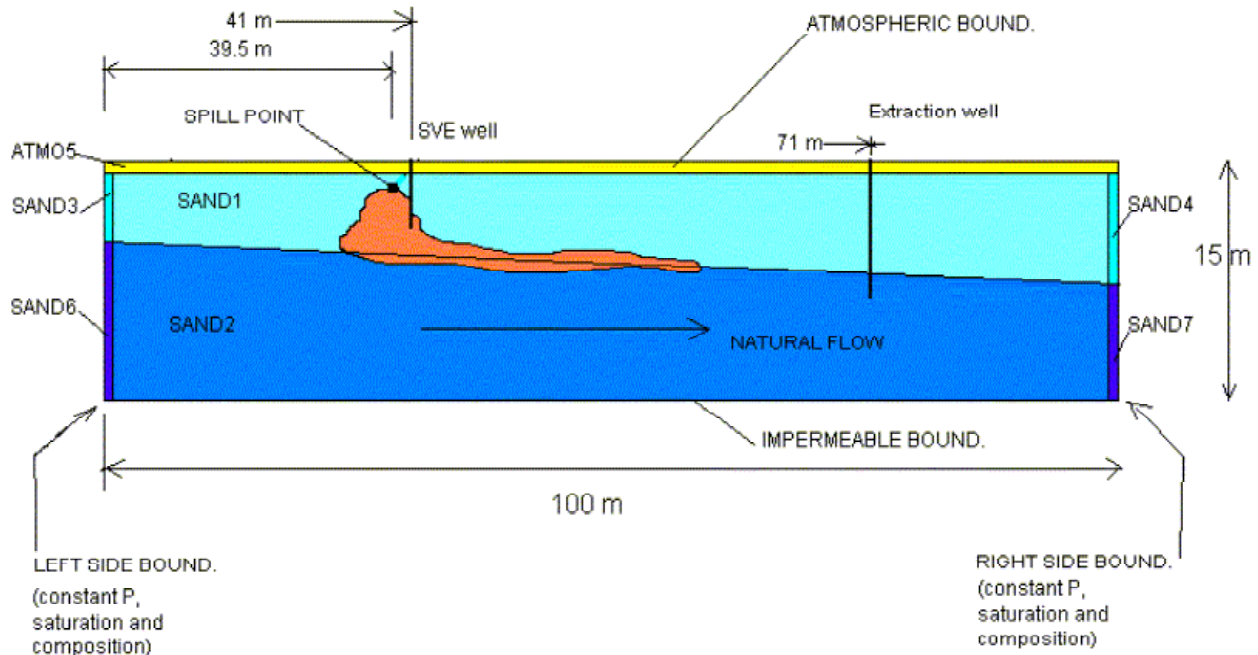

Figure 2. 2-D vertical section problem for simulating a multicomponent NAPL spill in the unsaturated zone.

The NAPL introduced in the subsequent spill simulation is assumed to consist of six components, n-decane, benzene, toluene, p-xylene, n-propylbenzene, and n-pentane, with relative concentrations specified through appropriate assignment of injection rates. Total VOC mass fractions in the aqueous phase at the end of the spill period (1 year) are shown in Fig. 3. The desired simulation time for the spill problem is reached after 120 time steps. The differences in volatility and solubility of the different NAPL components give rise to interesting compositional effects. For example, the NAPL phase in the injection grid block has a much larger concentration of n-pentane than in neighboring grid blocks, while all other component concentrations are smaller. The total VOC mass fraction dissolved in water is actually slightly larger in the grid blocks that are laterally offset from the source block than in the source block itself. In the vadose zone, the VOCs have spread almost symmetrically around the spill point by gas diffusion, as well as by advection driven by the larger density of NAPL vapors. In the saturated zone a plume of dissolved VOCs is being dragged to the right by the “natural” flow in the aquifer.

The third run segment simulates redistribution of the VOCs for a one-year period, using the SAVE file written at the end of the spill period as INCON file. Figures 4 and 5 show contour diagrams of, respectively, mass fractions of VOC dissolved in the aqueous phase, and NAPL phase saturation. Comparing Fig. 4 with Fig. 3 at the end of the spill period, it is seen that the VOC plume has increased in volume, and dissolved VOCs have penetrated deeper into the saturated zone. NAPL saturations in the upper part of the unsaturated zone are now slightly below the irreducible value of 0.05, having first been lowered by gravity drainage and subsequently, after $S_o = 0.05$ has been reached, by volatilization and

dissolution. A NAPL lense is floating on the water table (grid layer C). Total VOC inventory during the redistribution period declines from an initial value of 867.24 kg to a final value of 822.06 kg. This reduction occurs primarily through vapor diffusion across the land surface; small amounts of VOCs also leave the flow system by advection across the right boundary.

The final segment of this problem models extraction of VOCs for one year. GENER-data in the input file were modified to include a soil vapor extraction well, which produces on deliverability against a sandface pressure of 0.9×10^5 Pa from grid layers 4 through 8. Another extraction well produces from the saturated zone. At the end of the simulation, 470.48 kg of VOCs, corresponding to 54.3 % of the original inventory, are remaining in the flow system. Approximately 99.8 % of this inventory is present as a free NAPL phase, 0.18 % is dissolved in water, and 0.02 % is in the gas phase. The spatial extent of VOC contamination has been much reduced, compare Figs. 6 and 4. NAPL inventory in the vadose zone is very effectively reduced by the soil vapor extraction, and NAPL phase disappears from several grid blocks. Saturation of the NAPL lense floating on the water table (near $z = -0.25$ m) is reduced much more slowly. In the vadose zone, dissolved VOC mass fractions in the aqueous phase decrease rapidly at high elevations, and more slowly near the water table. Dissolved VOC concentrations at and below the water table show only very weak reductions.

The six VOCs used in this problem have extremely different phase partitioning properties (solubility, vapor pressure). Some discussion of the very strong compositional effects induced by this is given in the TMVOC user’s guide (Pruess and Battistelli, 2002).

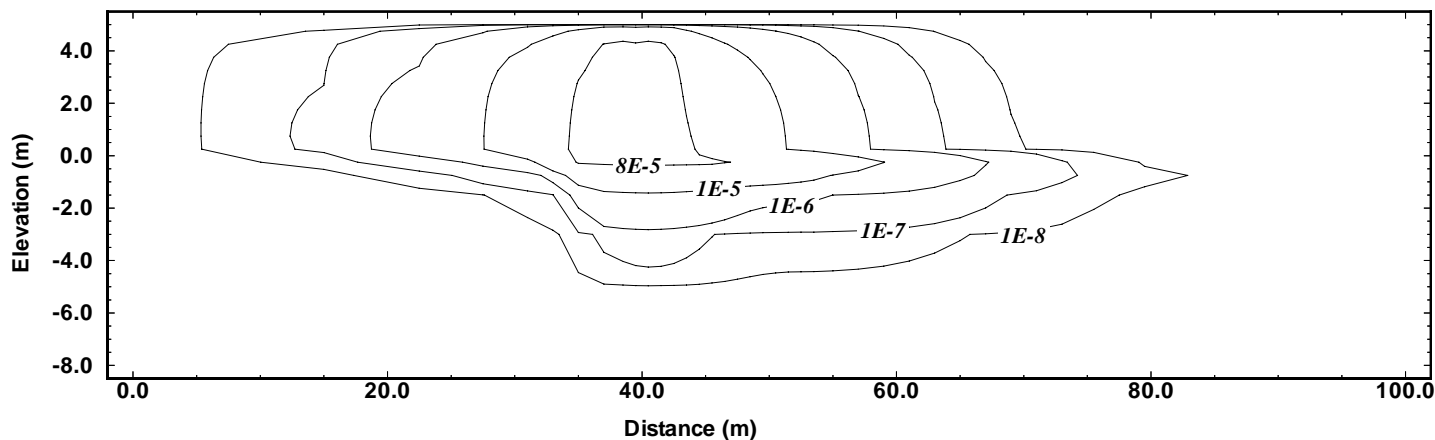

Figure 3. Contour plot of total VOC mass fraction in the aqueous phase at the end of the NAPL spill period (1 year).

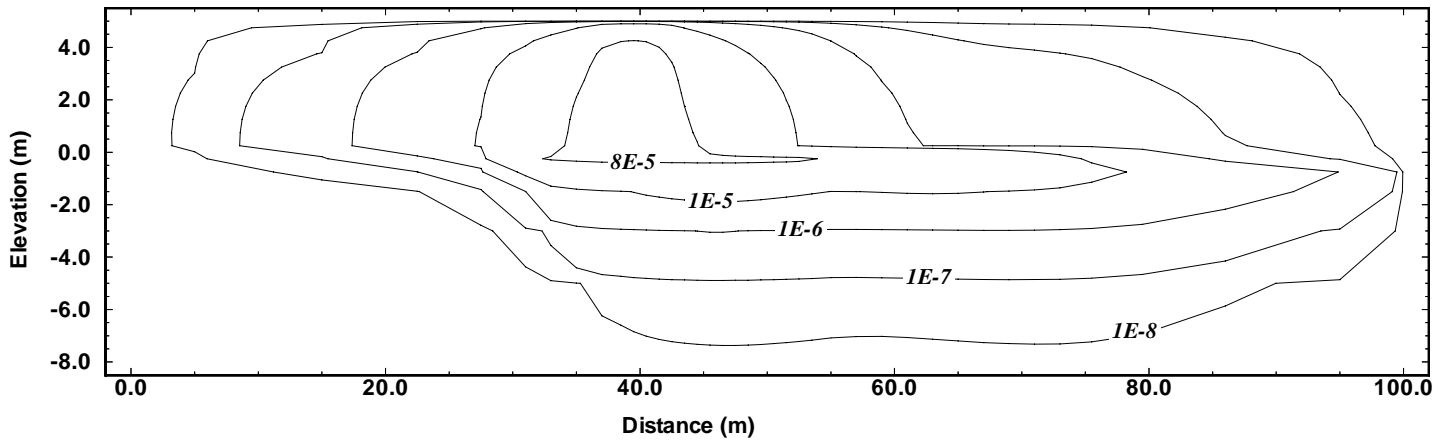

Figure 4. Contour plot of total VOC mass fraction in the aqueous phase at the end of the NAPL redistribution period.

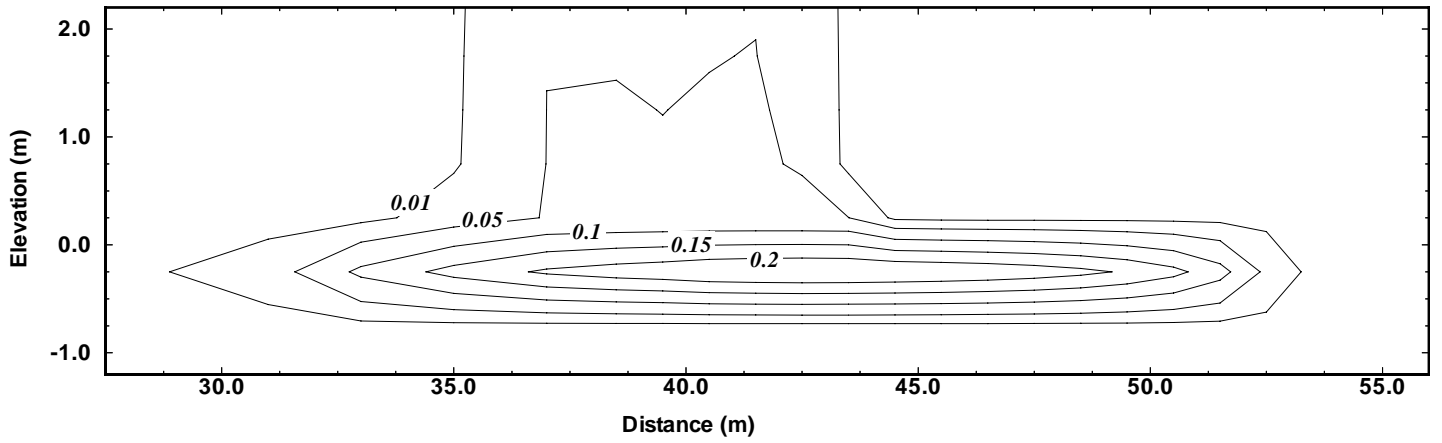

Figure 5. NAPL saturations at the end of the redistribution period.

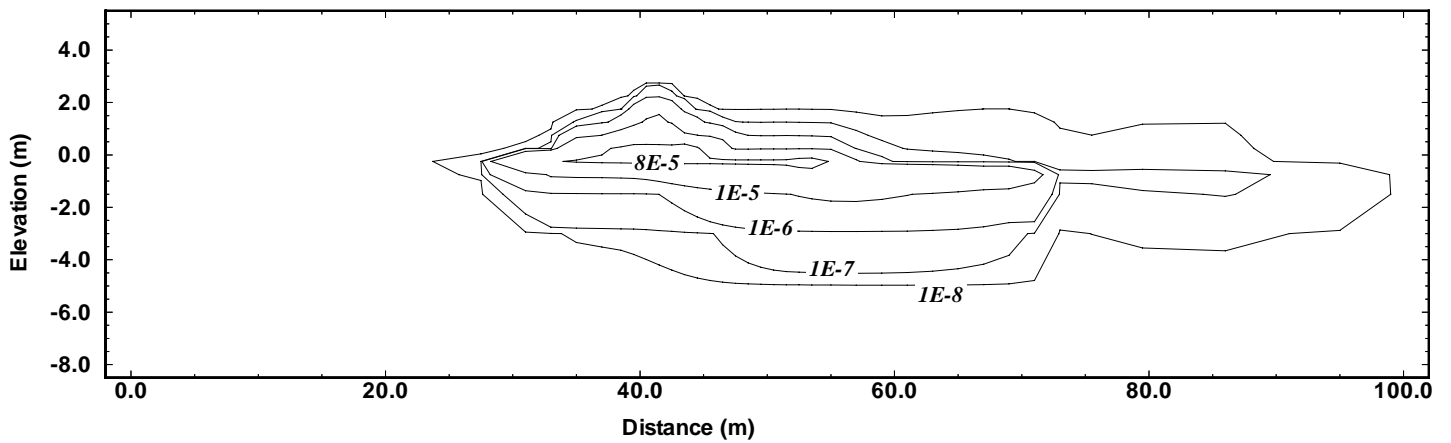

Figure 6. Contour plot of total VOC mass fraction in the aqueous phase at the end of the extraction period.

CONCLUDING REMARKS

TMVOC is a versatile numerical simulator for multi-phase flows involving aqueous, non-aqueous, and gas phases, which may include several volatile organic compounds, along with water and a variety of non-condensable gases. All possible phase combinations in a water-air-NAPL system are treated, including single-phase gas, aqueous, NAPL; two-phase gas-aqueous, gas-NAPL, and aqueous-NAPL; and three-phase gas-aqueous-NAPL. TMVOC can be used for modeling flow and transport processes in variably saturated media at ambient conditions, as well as under non-isothermal conditions such as electric resistance heating or steamflooding. The code is written in standard Fortran77, is part of the TOUGH2 family of codes (Pruess et al., 1999), and maintains cross-compatibility with the T2VOC code (Falta et al., 1995).

There is a tremendous variety of flow problems that can be tackled with TMVOC. The code was designed to be robust and be able to cope with difficult issues of phase change, phase partitioning of components, and compositional variation in fluid phases.

ACKNOWLEDGMENT

The TMVOC code is based on the PhD research of Adeyinka Adenekan. The authors are indebted to Stefan Finsterle and Chao Shan for their review and code testing, and for valuable suggestions. This work was supported, in part, by the U.S. Department of Energy through the Office of Basic Energy Sciences under Contract No. DE-AC03-76SF00098. Partial support was also provided by a grant from Aquater S.p.A. (ENI Group) to the Lawrence Berkeley National Laboratory in the frame of the REPIS project sponsored by the ENI Research Fund.

REFERENCES

- Adenekan, A.E. *Numerical Modeling of Multiphase Transport of Multicomponent Organic Contaminants and Heat in the Subsurface*, PhD thesis, University of California at Berkeley, Berkeley, CA, 1992.
- Adenekan, A.E., T.W. Patzek and K. Pruess. Modeling of Multiphase Transport of Multicomponent Organic Contaminants and Heat in the Subsurface: Numerical Model Formulation, *Water Resour. Res.*, Vol. 29, No. 11, pp. 3727-3740, 1993.
- Coats, K.H. and B.D. Smith. Dead-End Pore Volume and Dispersion in Porous Media, *Soc. Pet. Eng. J.*, 73-84, March 1964.
- Falta, R.W., K. Pruess, S. Finsterle, and A. Battistelli. *T2VOC User's Guide*, Lawrence Berkeley Laboratory Report LBL-36400, March 1995.
- Harvey, C. and S.M. Gorelick. Rate-limited Mass Transfer or Macrodispersion: Which Dominates Plume Evolution at the Macrodispersion Experiment (MADE) Site?, *Water Resour. Res.*, Vol. 36, No. 3, pp. 637 - 650, 2000.
- Ho, C.K. Numerical Simulation of Multicomponent Evaporation and Gas-Phase Transport Using M2NOTS. Proceedings TOUGH Workshop '95, LBNL, Berkeley, CA, March 20-22, 1995.
- International Formulation Committee. *A Formulation of the Thermodynamic Properties of Ordinary Water Substance*, IFC Secretariat, Düsseldorf, Germany, 1967.
- Meyer, C. A., R.B. McClintock, G.J. Silvestri and R.C. Spencer. *ASME Steam Tables*, The American Society of Mechanical Engineers, New York, U.S.A., 329 pp., 1977.
- Peng, D.Y. and D.B. Robinson. A New Two-Constant Equation of State, *I. & E. C. Fundamentals*, Vol. 15, No. 1, pp. 59 - 64, 1976.
- Prausnitz, J. M., R. N. Lichtenthaler, and E. G. de Azevedo. *Molecular Thermodynamics of Fluid-Phase Equilibria*, Prentice-Hall Inc., Englewood Cliffs, N. J., 1986.
- Pruess, K. and T.N. Narasimhan. A Practical Method for Modeling Fluid and Heat Flow in Fractured Porous Media, *Soc. Pet. Eng. J.*, Vol. 25, No. 1, pp. 14 - 26, February 1985.
- Pruess, K., C. Oldenburg, and G. Moridis, *TOUGH2 User's Guide, Version 2.0*, Report LBNL-43134, Lawrence Berkeley National Laboratory, Berkeley, Calif., 1999.
- Pruess, K. and A. Battistelli. *TMVOC, a Numerical Simulator for Three-Phase Non-Isothermal Flows of Multicomponent Hydrocarbon Mixtures in Saturated-Unsaturated Heterogeneous Media*, Lawrence Berkeley National Laboratory Report LBNL-49375, April 2002.
- Redlich, O. and J.N.S. Kwong. On the Thermodynamics of Solutions. V - An Equation of State. Fugacities of Gaseous Solutions, *Chem. Reviews*, Vol. 44, pp. 233 - 244, 1949.
- Reid, R.C., J.M. Prausnitz, and B.E. Poling. *The Properties of Gases and Liquids*, McGraw-Hill, New York, 1987.
- Soave, G. Equilibrium Constants from a Modified Redlich-Kwong Equation of State, *Chem. Eng. Sci.*, Vol. 27, No. 6, pp. 1197 - 1203, 1972.