

Lawrence Berkeley National Laboratory

Recent Work

Title

RESONANCE MAPS FOR LINEAR ACCELERATORS

Permalink

<https://escholarship.org/uc/item/1rf1z9bp>

Authors

Kitchen, Sumner W.
Smits, Robert G.

Publication Date

1952-02-27

UNIVERSITY OF CALIFORNIA - BERKELEY

UNCLASSIFIED

UCRL-

1739

C.2

TWO-WEEK LOAN COPY

*This is a Library Circulating Copy
which may be borrowed for two weeks.
For a personal retention copy, call
Tech. Info. Division, Ext. 5545*

RADIATION LABORATORY

UCRL-1739

C.2

UCRL-1739
Unclassified
~~Instrumentation~~
Internal

UNIVERSITY OF CALIFORNIA
Radiation Laboratory

cy 3 -
7

Contract No. W-7405-eng-48

UNCLASSIFIED

RESONANCE MAPS FOR LINEAR ACCELERATORS

Sumner W. Kitchen and Robert G. Smits

February 27, 1952

Berkeley, California

RESONANCE MAPS FOR LINEAR ACCELERATORS

Sumner W. Kitchen and Robert G. Smits

Radiation Laboratory, Department of Physics
University of California, Berkeley, California

February 27, 1952

ABSTRACT

In the design of resonant accelerators, it is desirable to choose parameters of resonance which can be related to particle motion such as g/l and β . If the mode and drift tube configuration are chosen, there remain only four independent variables for resonance. Resonance maps are presented for g/l and β as functions of drift tube diameter and length and of frequency for a fixed cavity diameter. Methods of using this data in designing a resonant system of any size are indicated.

RESONANCE MAPS FOR LINEAR ACCELERATORS

Sumner W. Kitchen and Robert G. Smits

Radiation Laboratory, Department of Physics
University of California, Berkeley, California

February 27, 1952

The successful operation of the Berkeley 40 foot linear accelerator, indicated the feasibility of higher energy machines¹. As a basis for the design of such future accelerators, a study of the pertinent resonance conditions was undertaken.

Because a standing wave linear accelerator consists of a long resonant cavity loaded with "drift tubes", it can be subdivided into sections at the planes of electrical symmetry in mid-drift tube and mid-gap, each section resonating at the same frequency. For this reason, it is possible to map resonant conditions by using a single subsection whose length and drift tube geometry can be varied. Fig. 1 shows the details of the cavity used for these measurements. Since high accuracy is required, all fixed dimensions were made to ± 0.001 inch and all variable dimensions measured to the same accuracy. Similarly, the resonant frequencies of the cavity were read to four significant figures. Fig. 2 is a block diagram which indicates the measuring technique. Checks for spurious resonances were made by inserting a metal rod along the axis.

In order to describe a loaded cavity so as to fix its resonant frequency, one has to give the shape, or configuration, of both the unloaded cavity and the loading element, the dimensions of each, and the mode of oscillation. The mode of oscillation for a linear accelerator is the TM_{010} . The shape of the cavity is that of a hollow cylinder and the configuration of the drift tubes studied here is shown in Fig. 3. This contour was chosen in an effort to minimize high surface gradients. Having chosen the configurations of the cavity and the

drift tube, two dimensions for each, diameter and length, suffice to complete the description of the loaded cavity. Hence, there are five quantities as yet unspecified, the four dimensions and the frequency. Any four of these are independent and may be chosen at will but the fifth is then specified. Inasmuch as the measurements are made on a scale model, it is preferable to describe the loaded cavity in terms of dimensionless quantities as far as possible. Furthermore, the fact that these cavities must accelerate particles dictates choice of dimensionless quantities that can be related to the particle motion.

The accelerator consists of a series of accelerating spaces and drift spaces defined by the gap lengths between drift tubes and the drift tube lengths. For a particle to remain at the synchronous phase it must travel the distance from a point in one gap to the corresponding point in the next gap with an average velocity v in a time τ equal to the period of the resonant frequency. Consequently, both a synchronous particle and the accelerating cavity may be described by

$$\beta = \frac{v}{c} = \frac{l}{\lambda}$$

Here l is arbitrarily defined as the distance between planes of electrical symmetry in either successive gaps or successive drift tubes and λ is the free space wavelength of an electromagnetic wave at the resonant frequency of the accelerator. By this definition, the β of the cavity of Fig. 1 is equal to twice its length divided by the λ of its resonant frequency.

The degree of acceleration of a particle in a length l (or period τ) depends partly on the time spent in the gap space relative to τ . This time is a function of the ratio of the total gap space, g , in the length, l , to the length l . Therefore g/l is chosen as a second dimensionless quantity. (Note that g plus drift

tube length, t , is equal to ℓ .) Hence two of the five variables have been put in dimensionless form, the length of the cavity and the length of the drift tube.

For the three remaining variables, D , the inside diameter of the cavity, d , the outside diameter of the drift tube, and ν , the resonant frequency of the loaded cavity, there are a variety of dimensionless choices such as D/d , D/λ , d/λ , g/d , etc. Whatever the choice, however, all three cannot be dimensionless. Furthermore, if altogether four dimensionless variables are chosen such that every choice of three forms a set of mutually independent variables, then the set of four will form a relationship which is independent of the value of the non-dimensionless variable. For example, the interdependence of g/ℓ , ℓ/λ , D/d , and d/λ is independent of the value of λ (or any one of the dimensions). On the other hand, the set of g/ℓ , ℓ/λ , D/d , and t/λ is not independent of the value of λ because g/ℓ , ℓ/λ , and t/λ are not mutually independent. Another way of looking at this specific case is to say that the second set, contrary to the first, does not describe all four required dimensions of the loaded cavity in terms of the wavelength.

At times in linear accelerator design, the geometry is not of primary interest, but rather quantities such as shunt impedance or the ratio of fields in one part of the cavity to those in another part. Any such quantity may be chosen to be an independent variable in place of a geometric variable, but whatever the combination of variables, once the cavity and drift tube configurations, the mode of oscillation and the surface conductivity part of the shunt impedance have been chosen, there remain only four independent variables.

Because it was impossible to set the cavity to resonate at a particular frequency, within the desired accuracy, the data was taken and is presented in the form of Figs. 4-15. Fig. 16 illustrates the form of the data obtained from these graphs

when d/λ is chosen to be constant at 0.1025. Because the relationship between l/λ , g/l , and D/d has been fixed by the choice of d/λ , it is now possible to design an accelerator in terms of only two independent variables, g/l and l/λ , before specification of the final independent variable, which will determine the actual dimensions and frequency. If a different value had been chosen for d/λ , a different but similar relationship between g/l , l/λ , and D/d would have been obtained. However, if D/λ had been chosen to be a variable in place of D/d , another but not similar relationship would have been established².

This report is the first in a series presenting both data and principles useful in the design of resonant linear accelerators. The future reports will present resonance data on other drift tube configurations, shunt impedance data, and methods of optimizing accelerator design.

It is desired at this time to acknowledge the contributions of the many individuals who assisted the program and especially those of Dr. Andrew Longacre, who both initiated the program and organized the major portion of it.

¹ AECU-120, L. W. Alvarez et al., "Berkeley Proton Linear Accelerator".

² Op. cit. L. W. Alvarez et al., p. 36

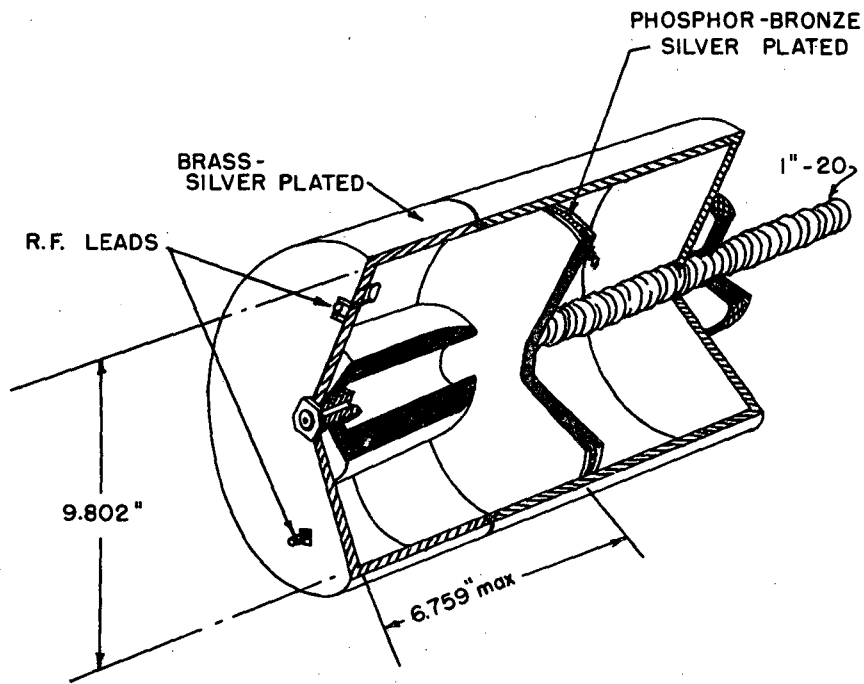

9.8" PRECISION CAVITY MU3418

Fig. 1

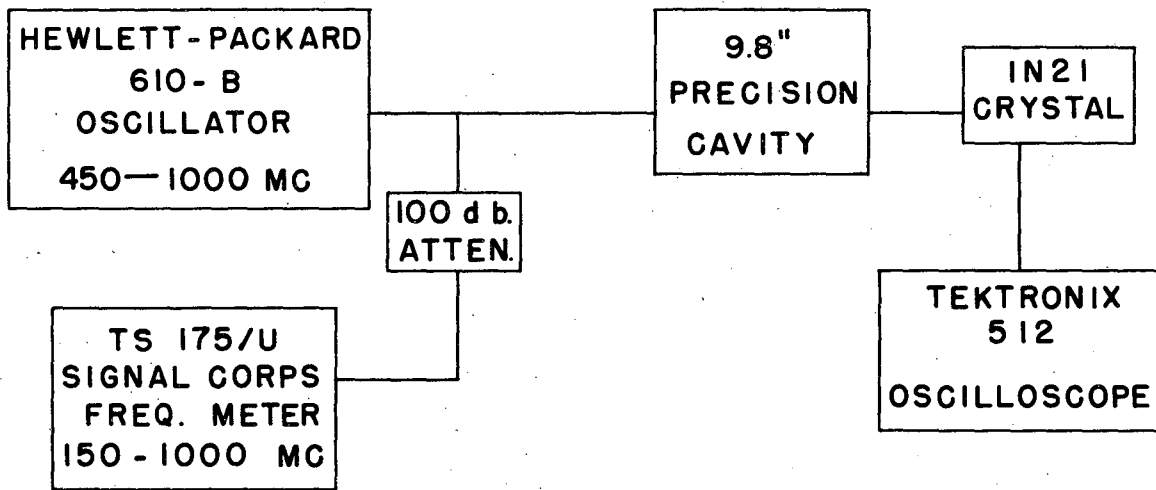
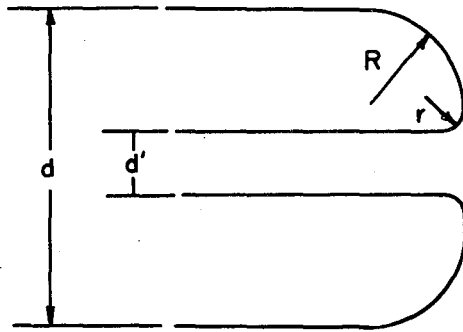

FIG. 2 RESONANT FREQUENCY MEASURING SYSTEM

MU3421

Fig. 2



$$\frac{d}{d'} = .360$$

$$\frac{d}{R} = .248$$

$$\frac{r}{d} = .072$$

THICK CYLINDER DRIFT TUBE CONFIGURATION

MU3417

Fig. 3

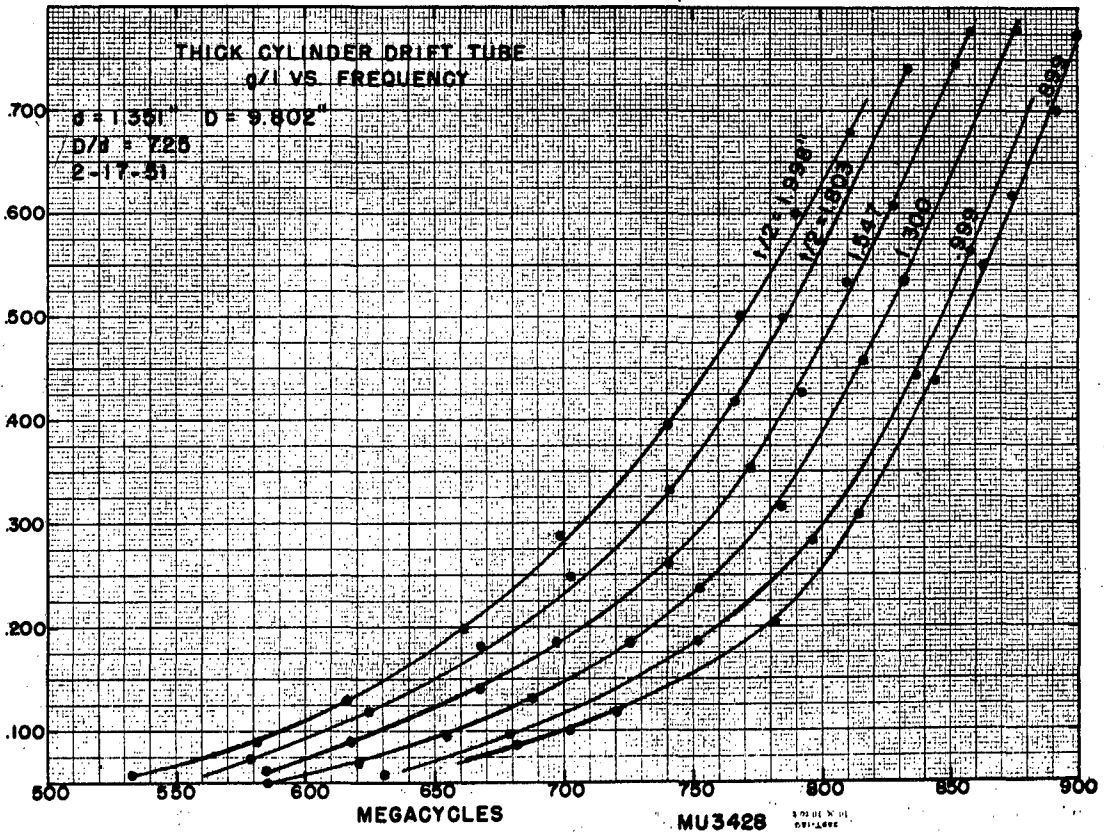

Fig. 4A

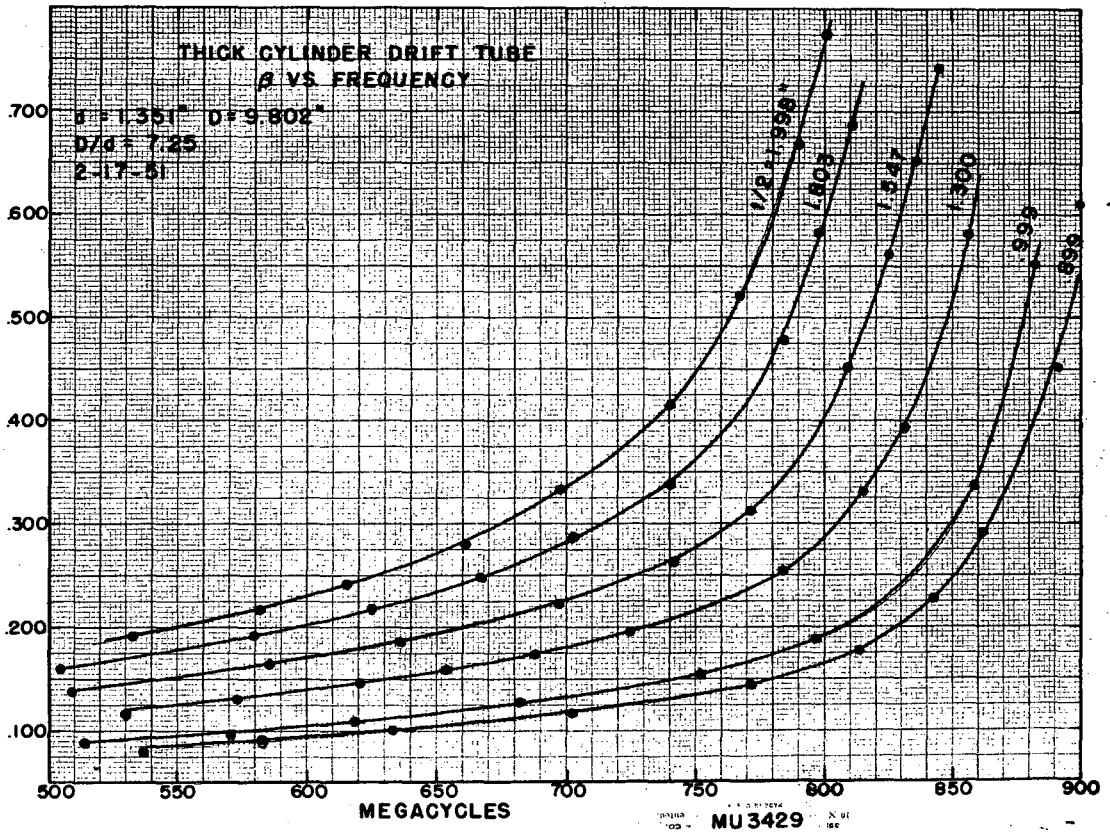

Fig. 4B

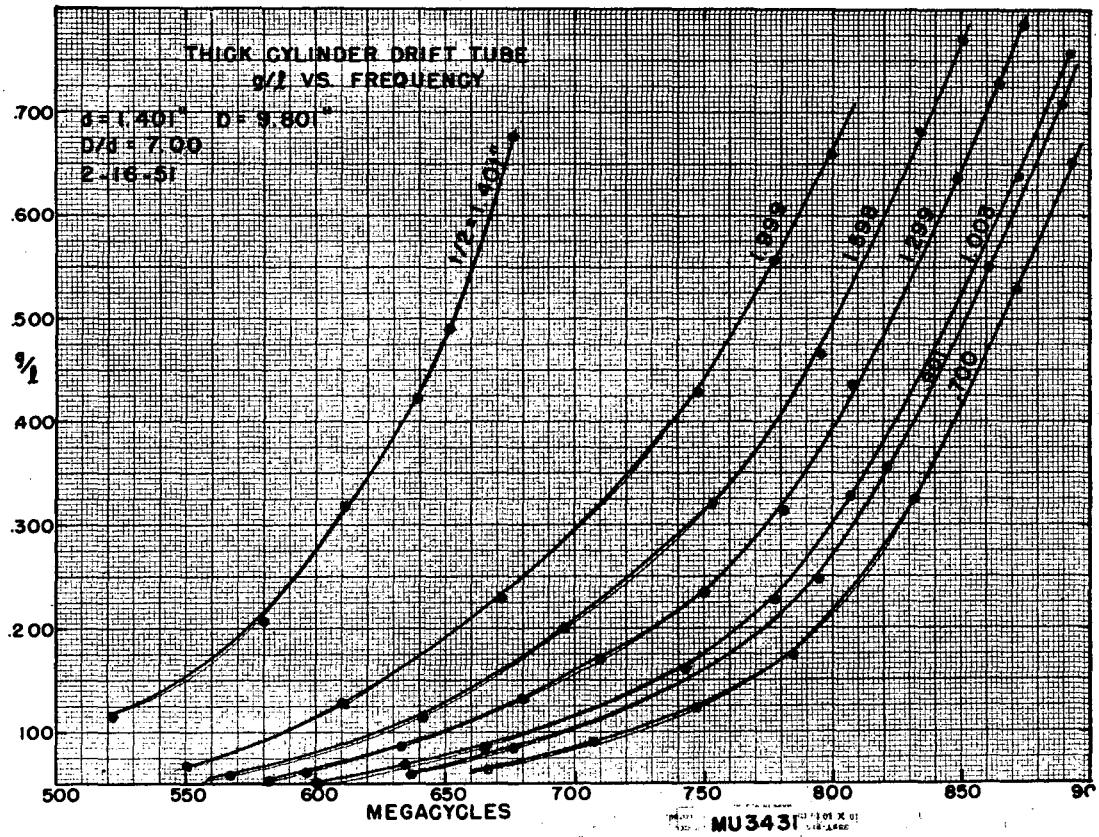

Fig. 5A

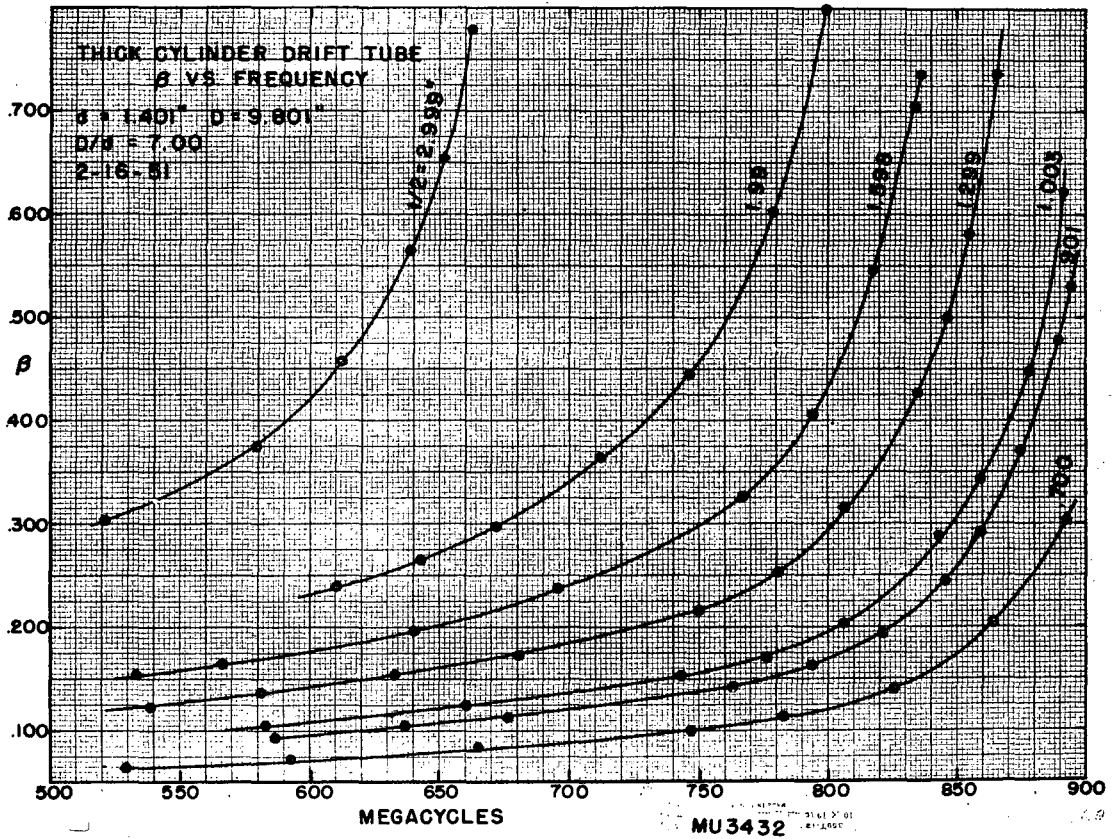

Fig. 5B

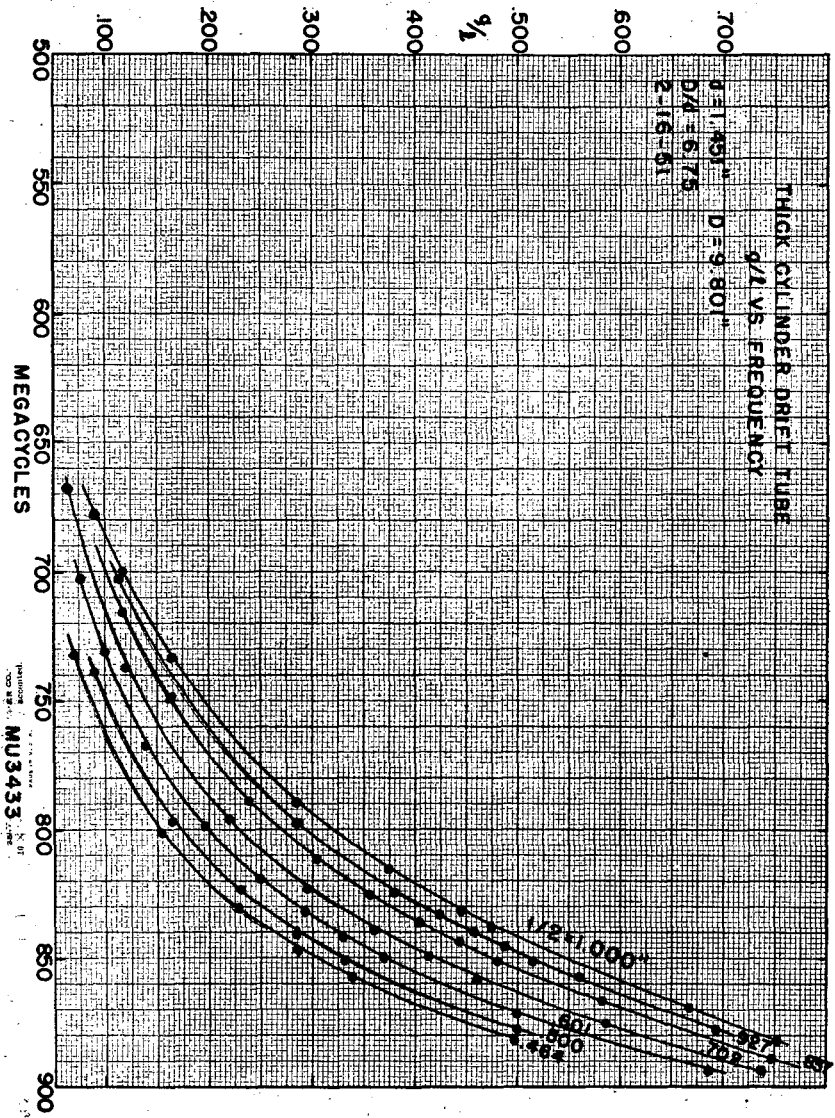

Fig. 6A

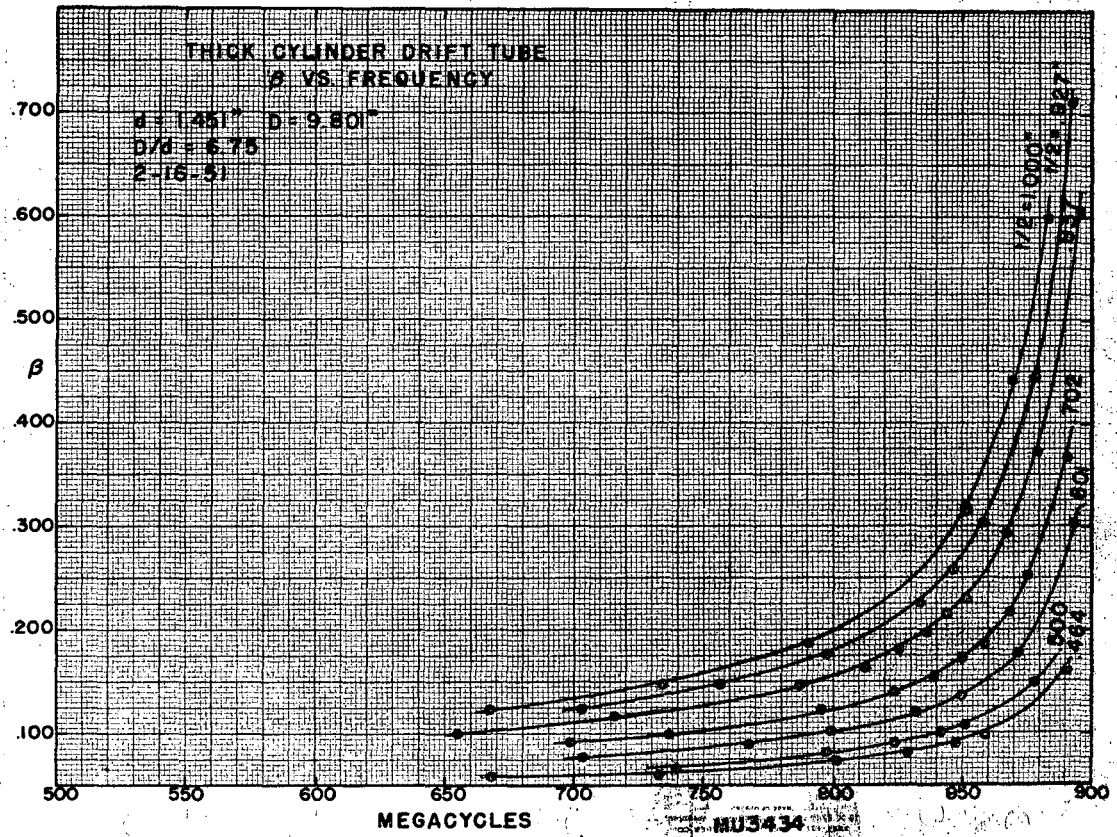

Fig. 6B

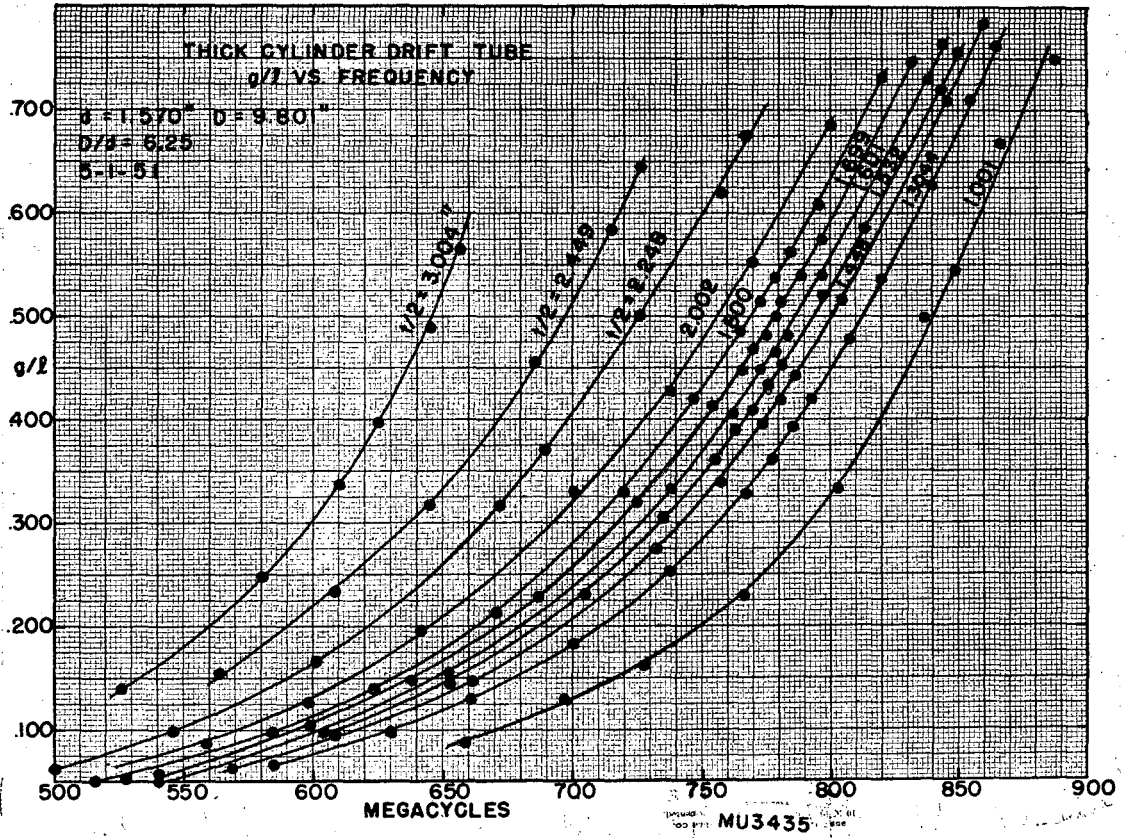

Fig. 7A

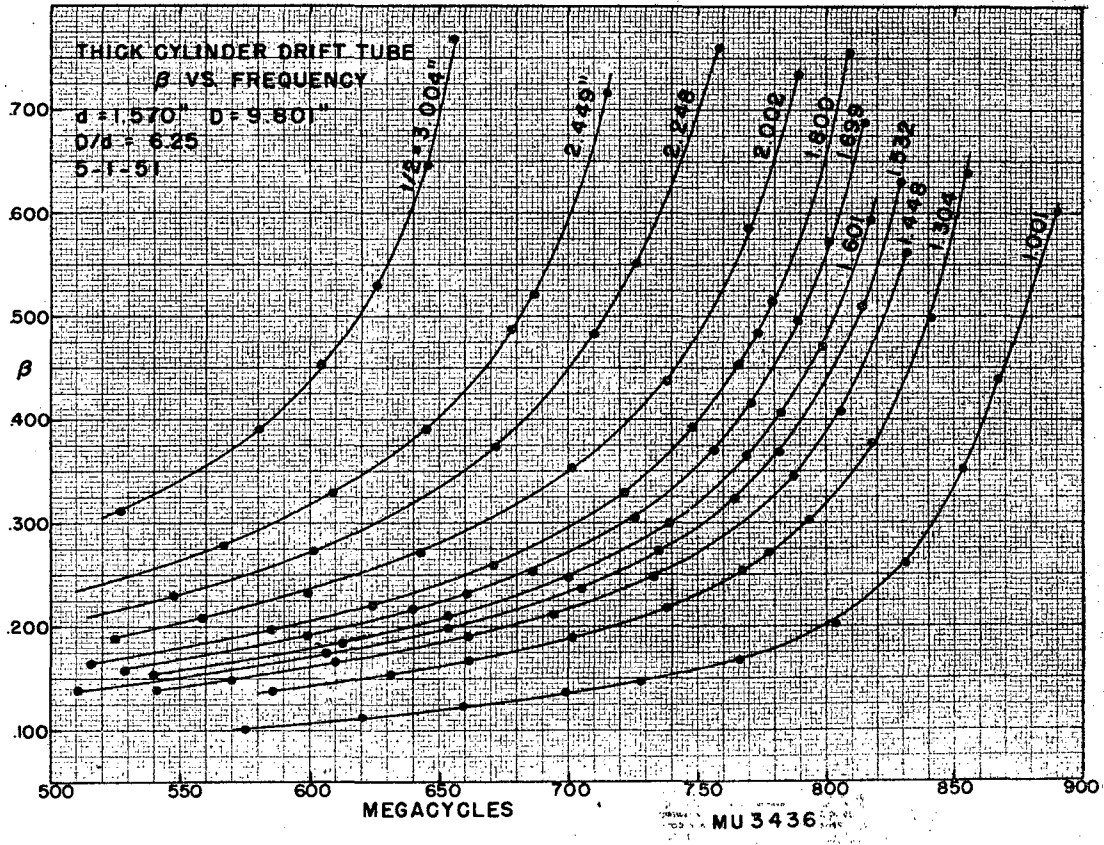

Fig. 7B

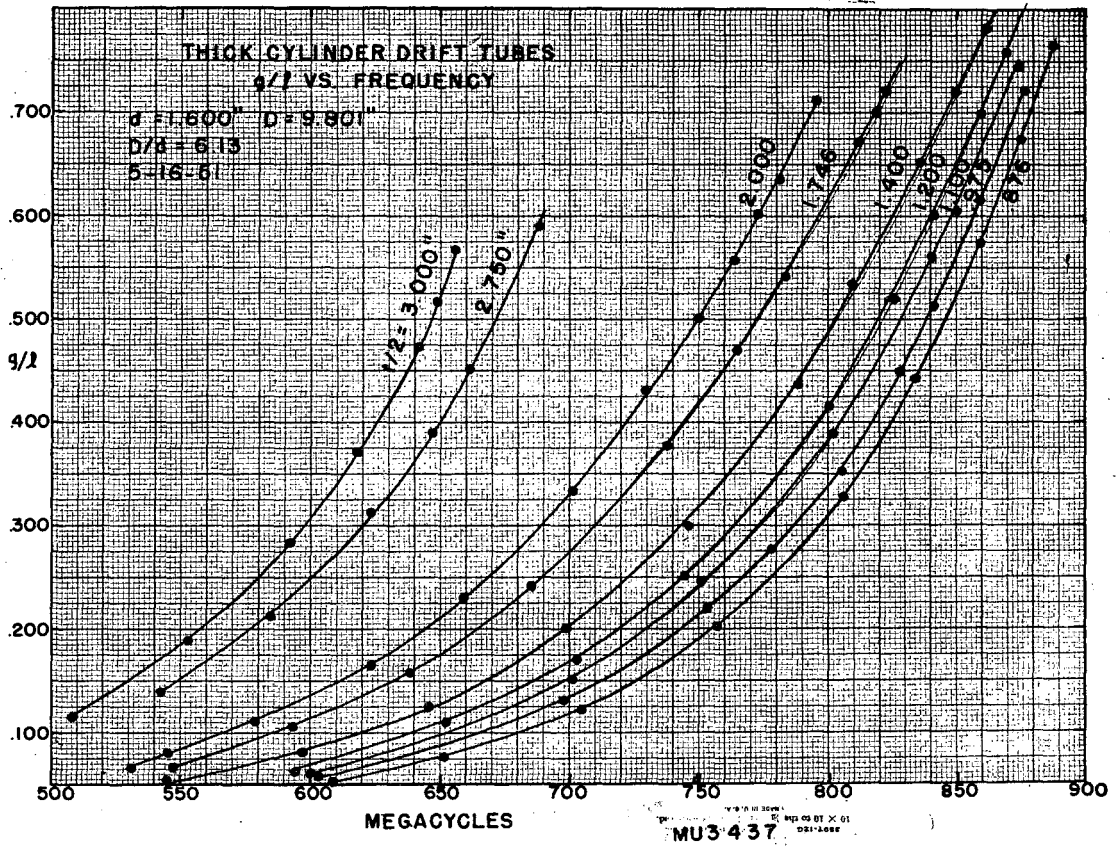

Fig. 8A

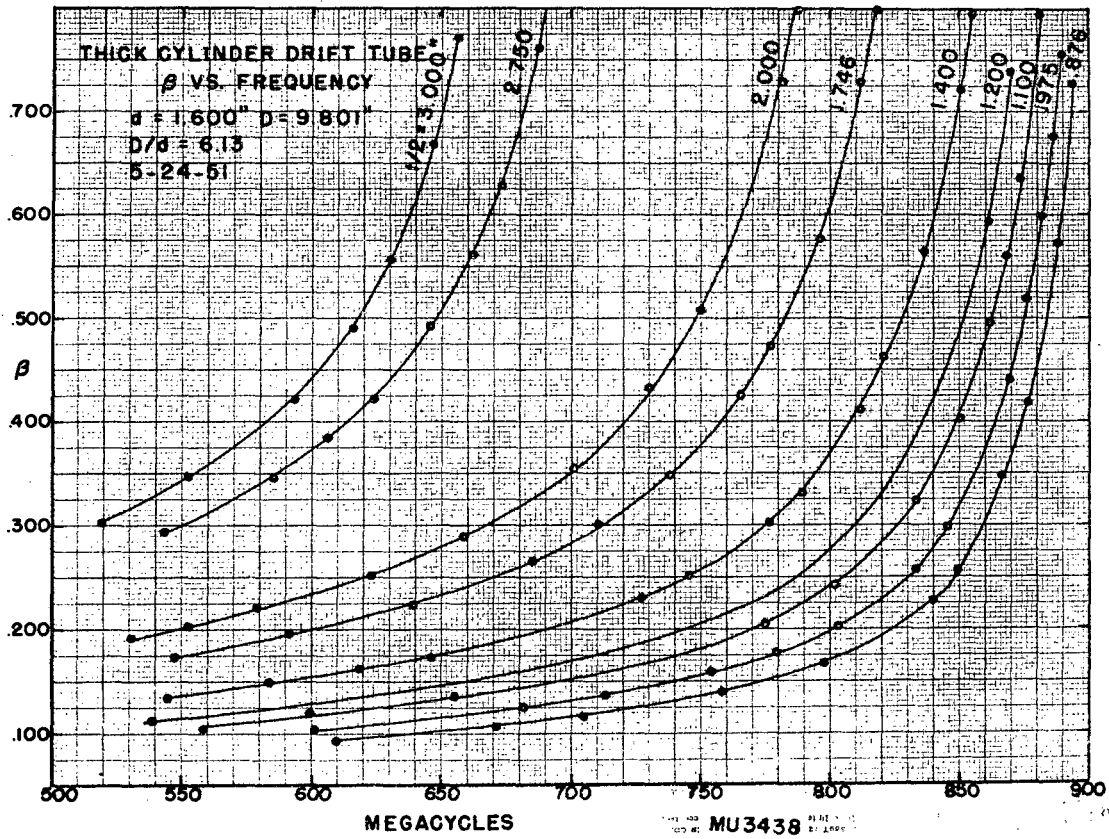

Fig. 8B

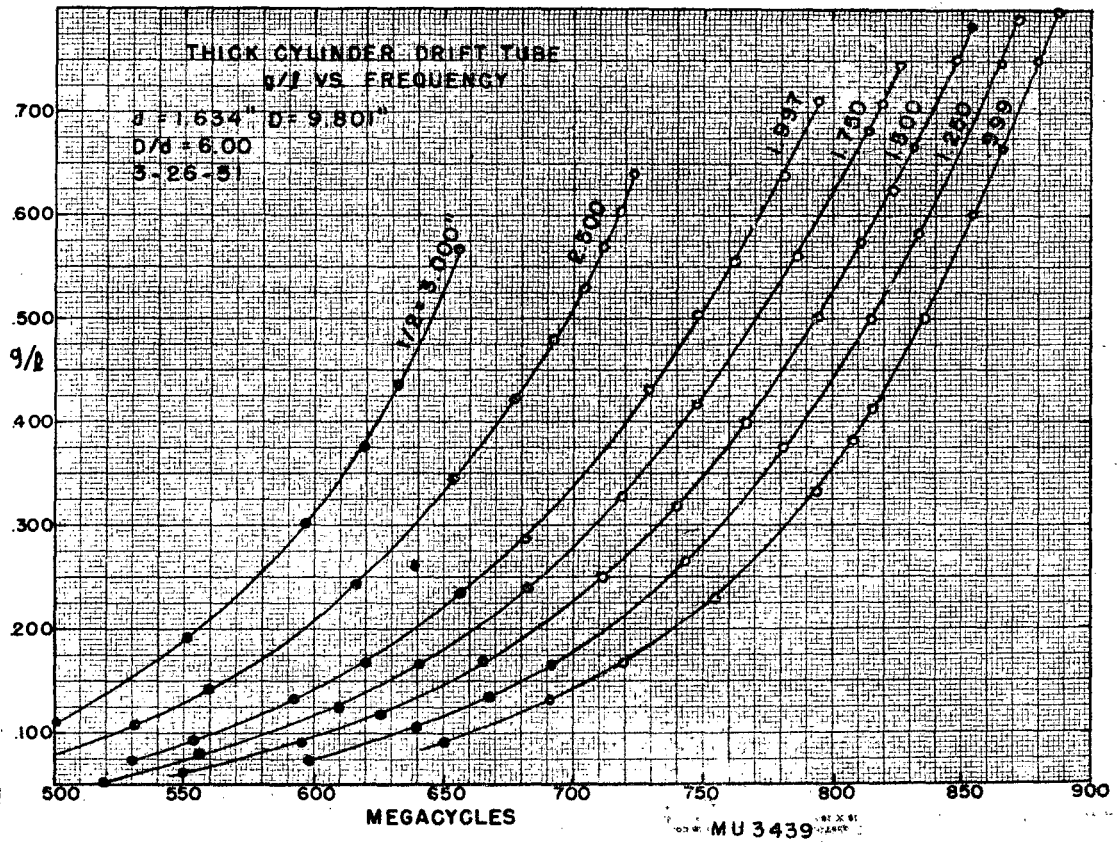

Fig. 9A

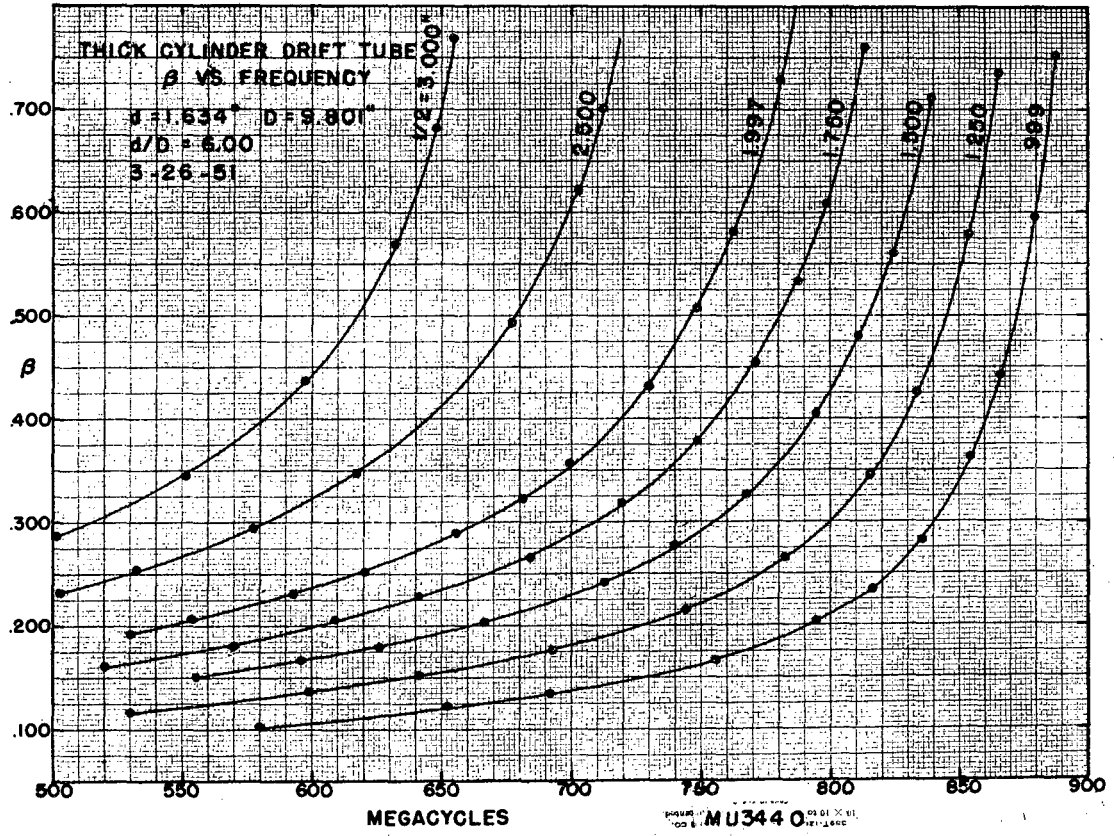

Fig. 9B

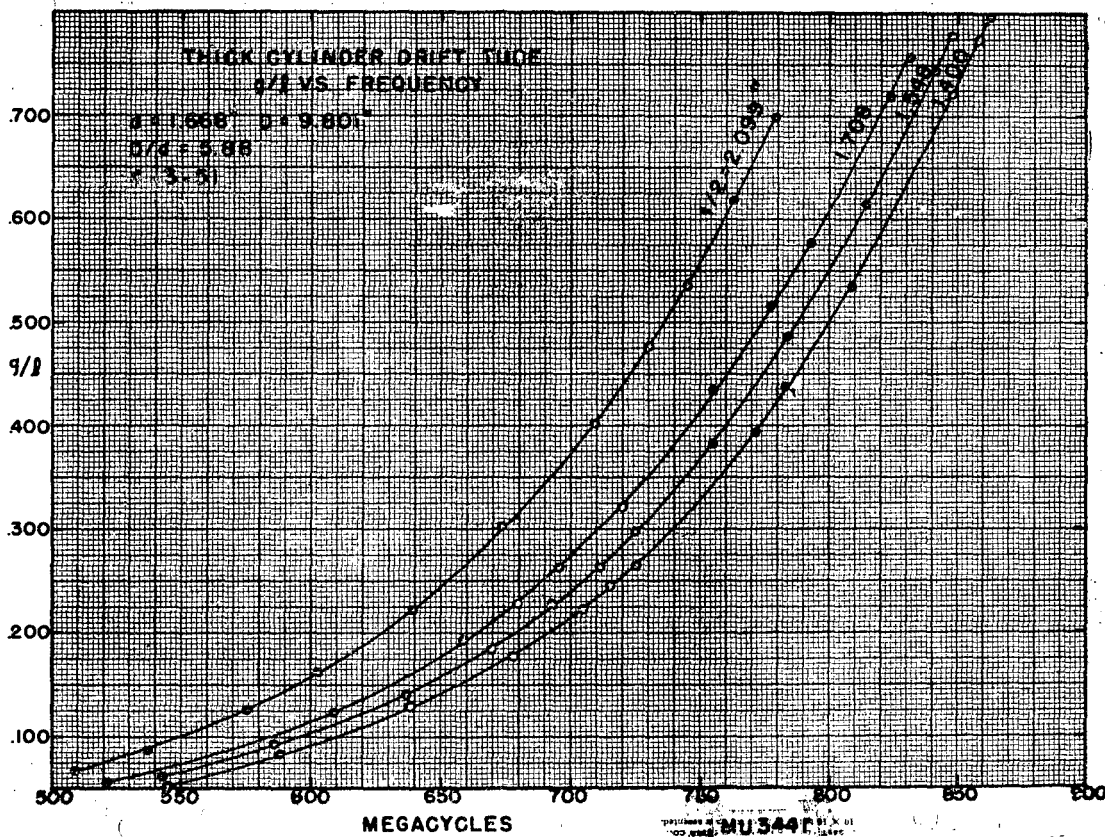

Fig. 10A

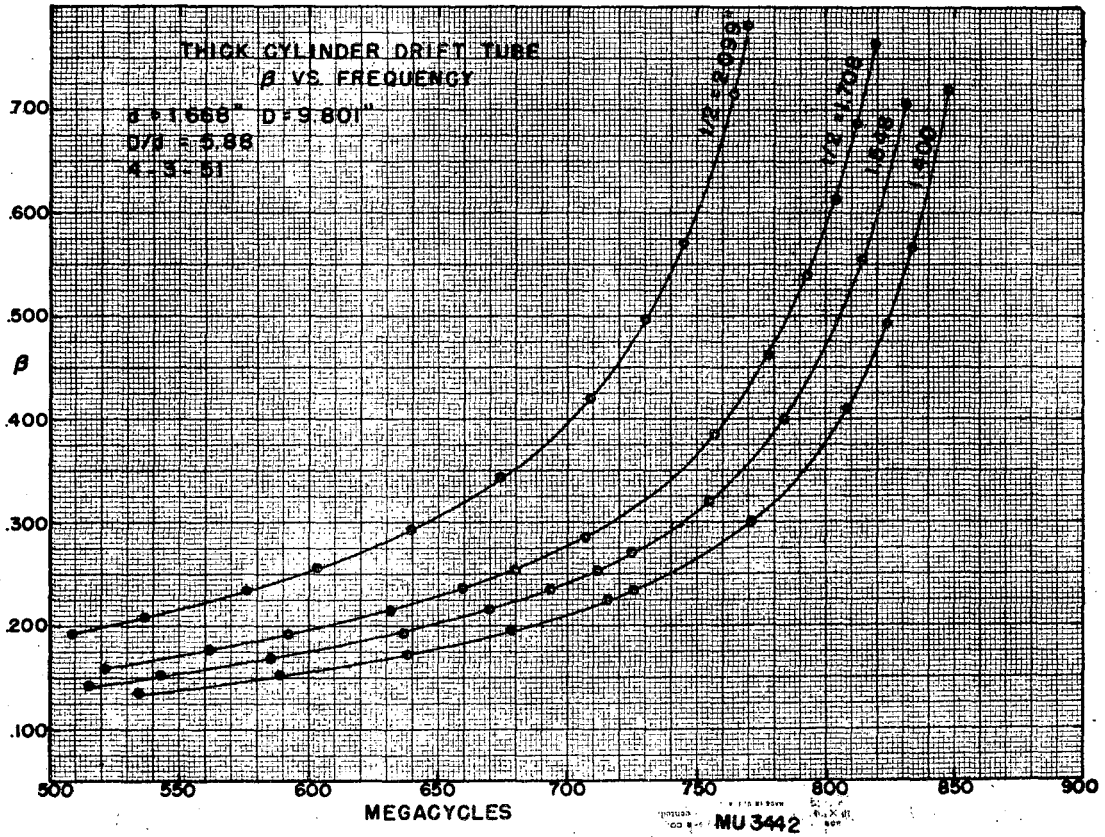

Fig. 10B

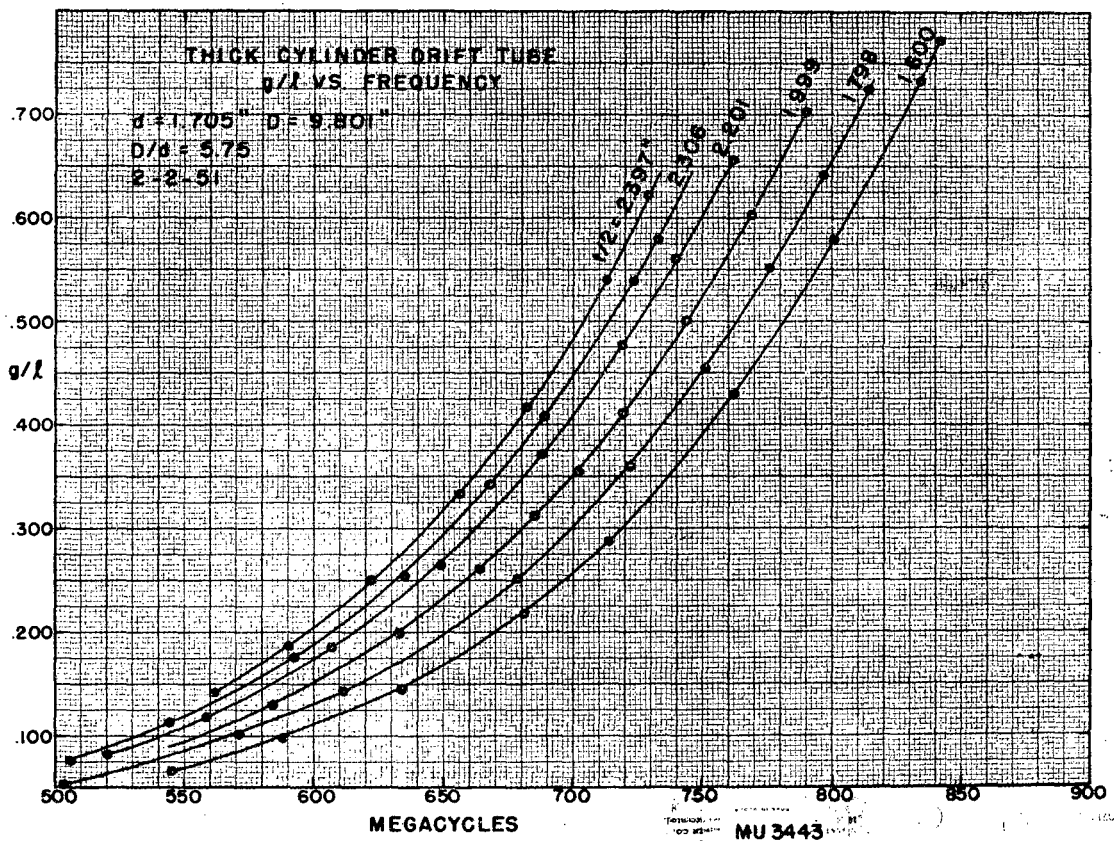

Fig. 11A

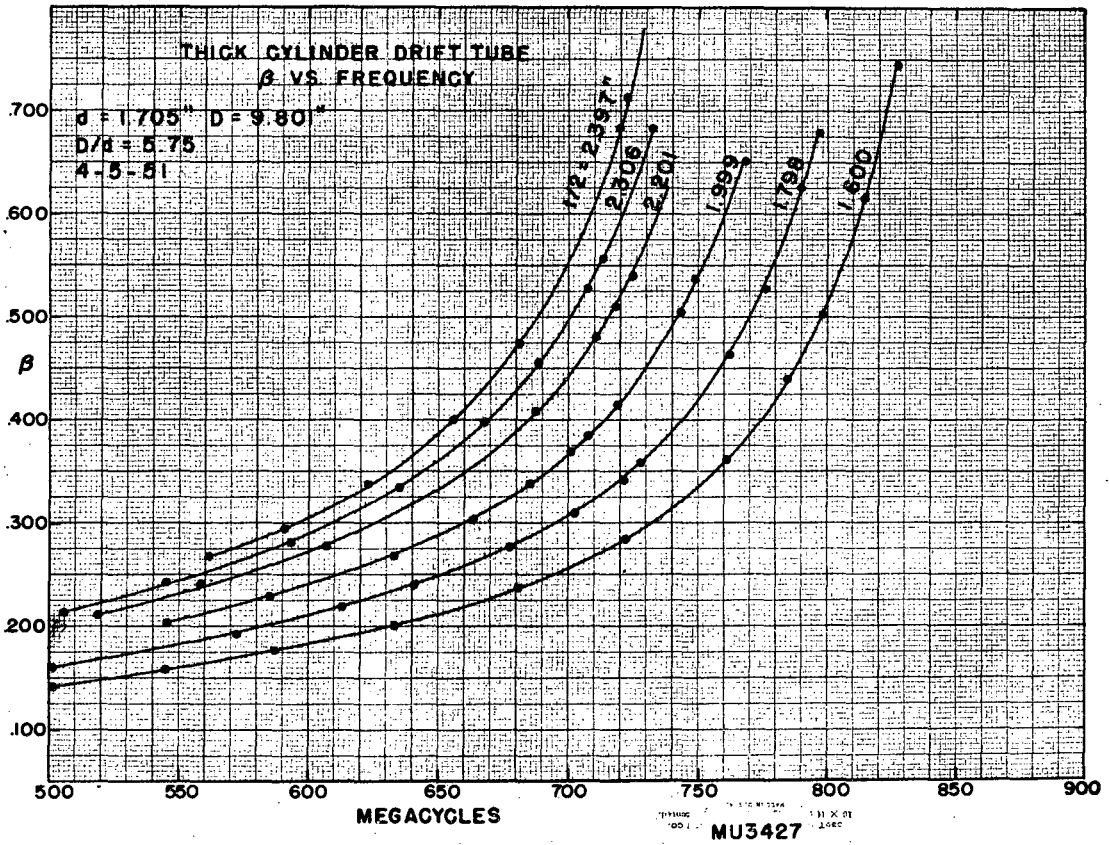

Fig. 11B

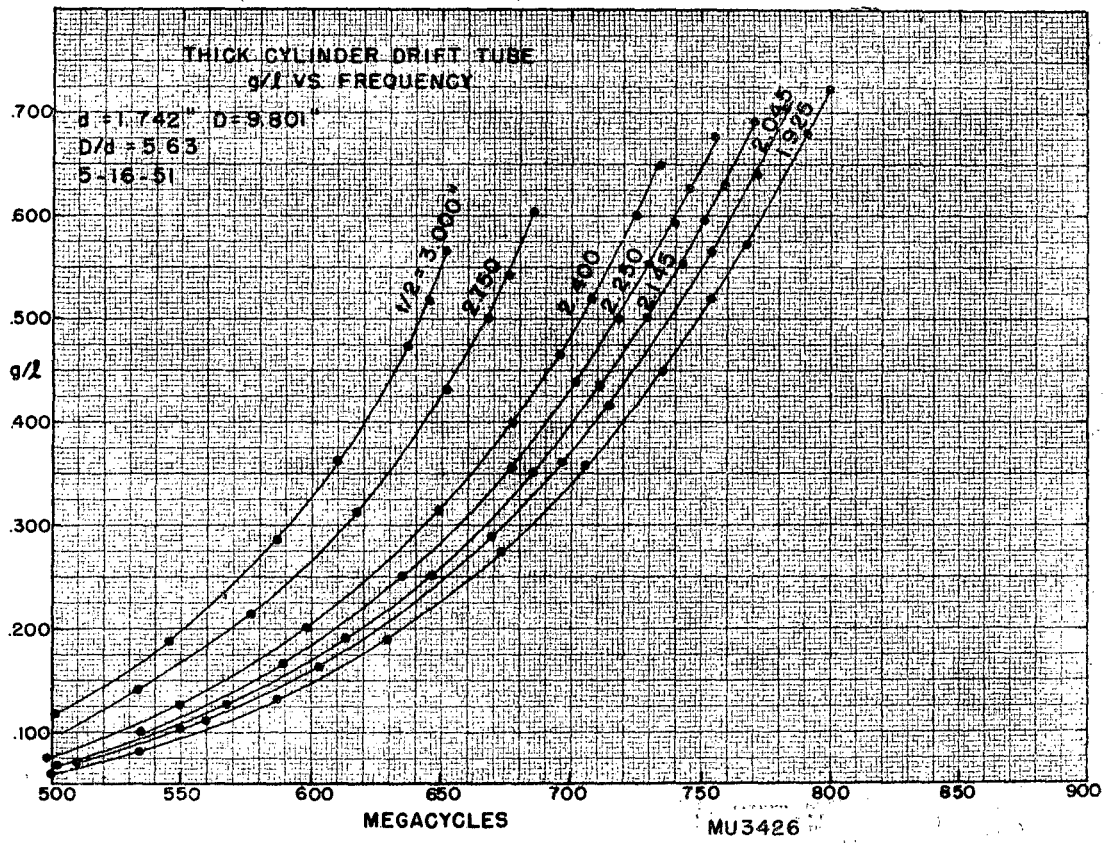

Fig. 12A

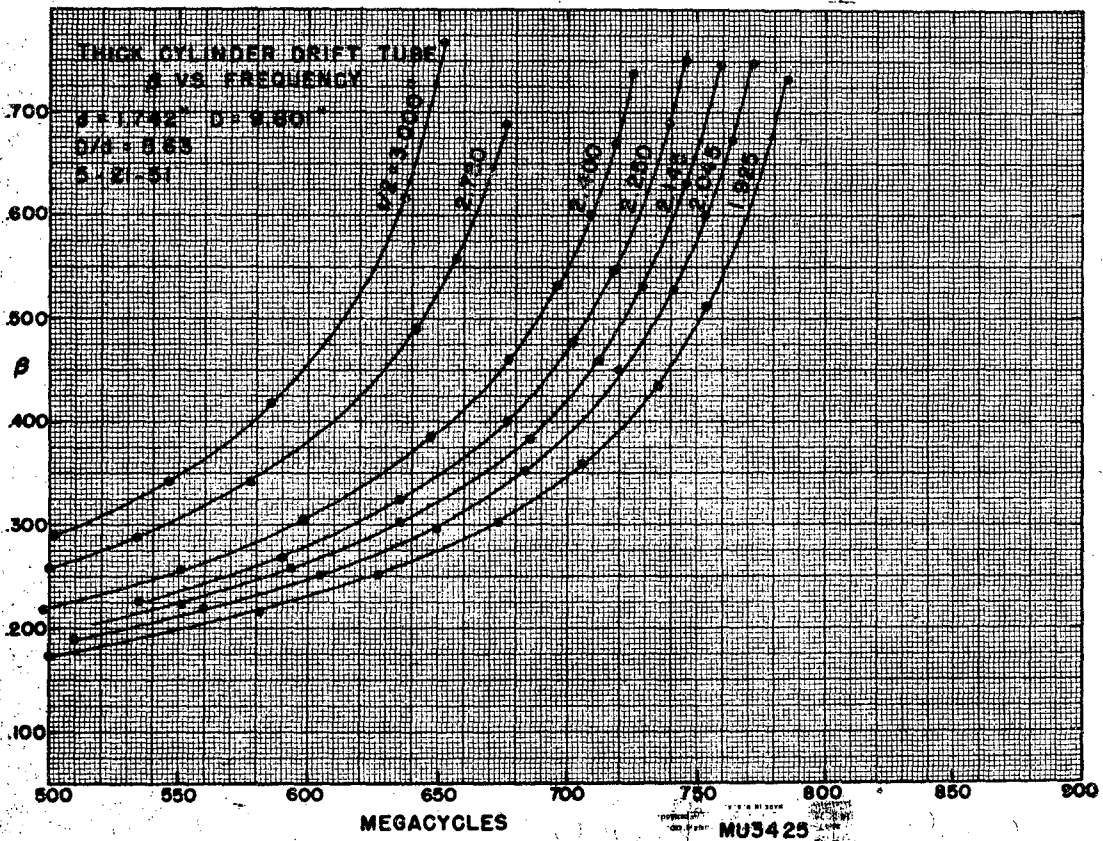

Fig. 12B

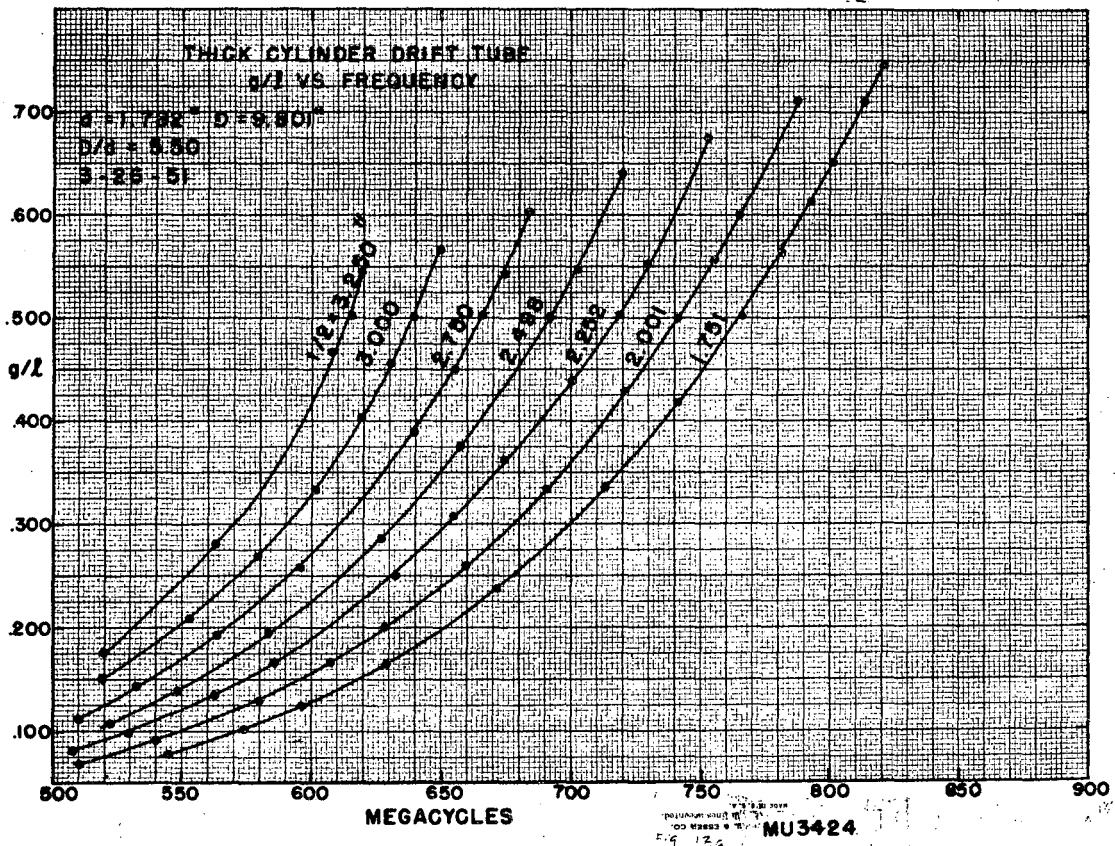

Fig. 13A

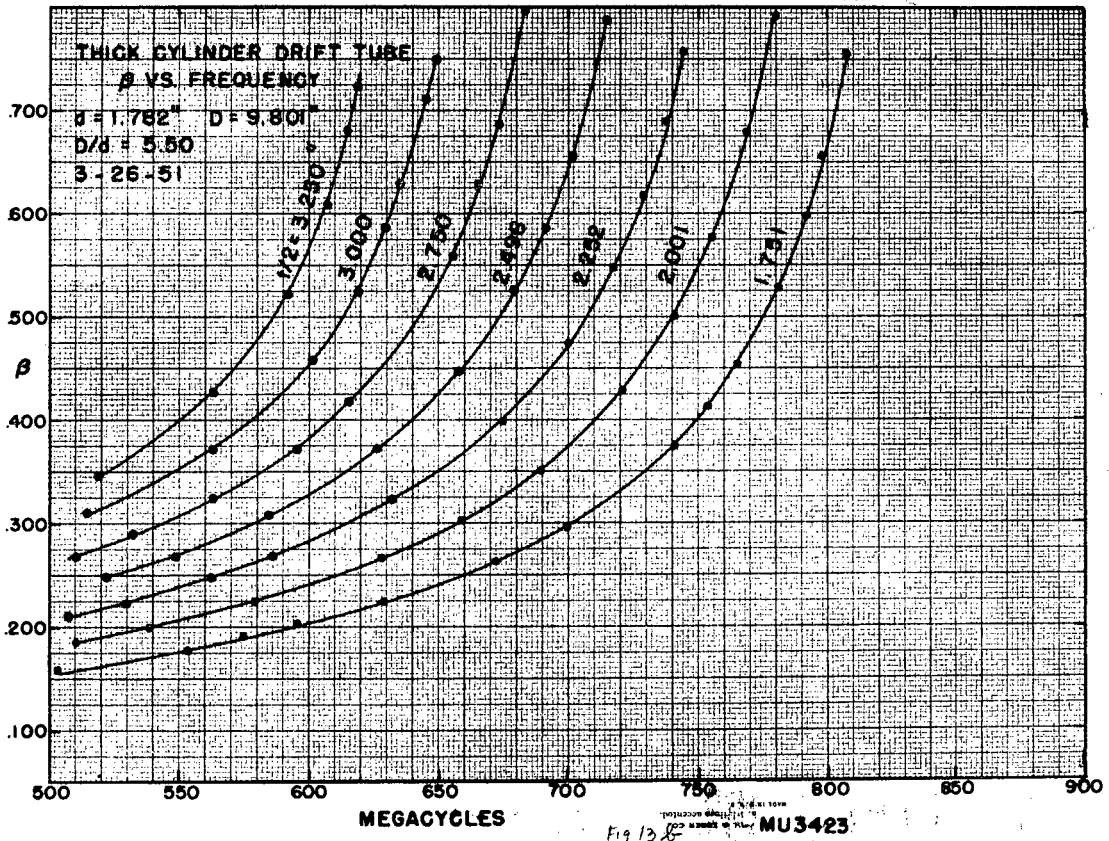

Fig. 13B

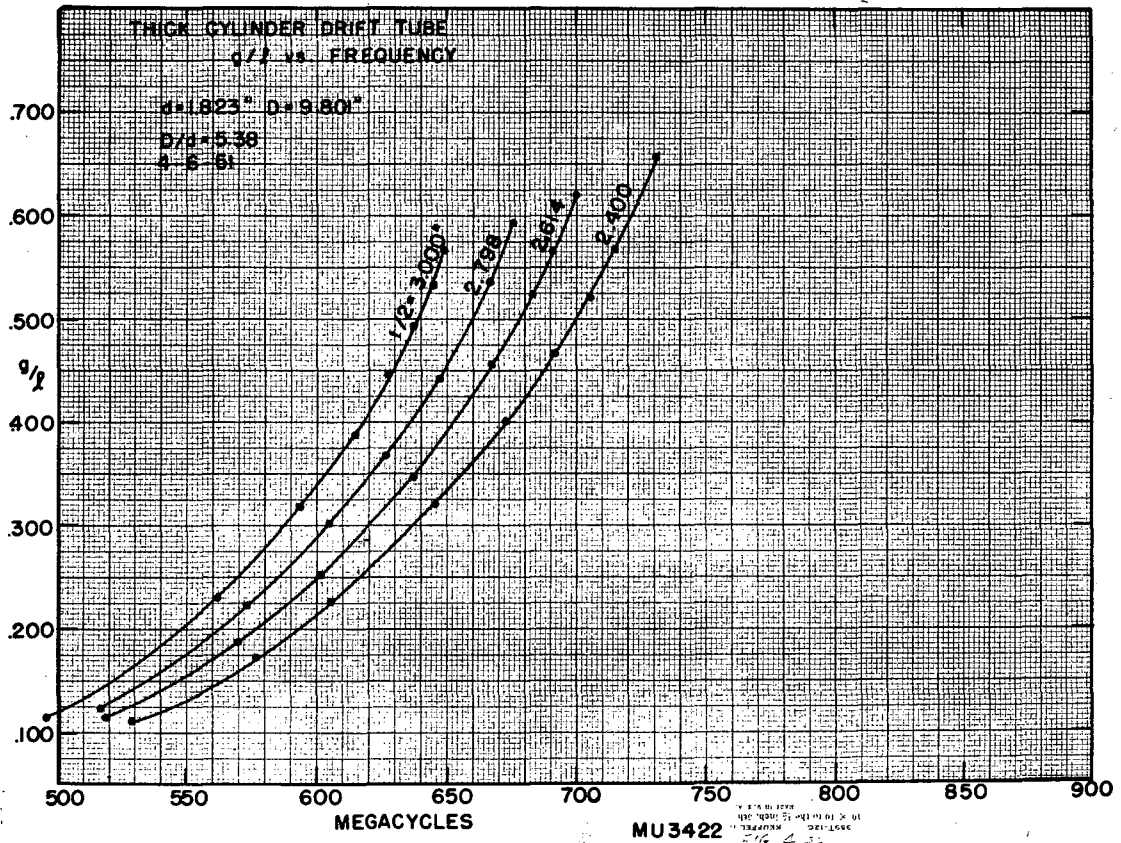

Fig. 14A

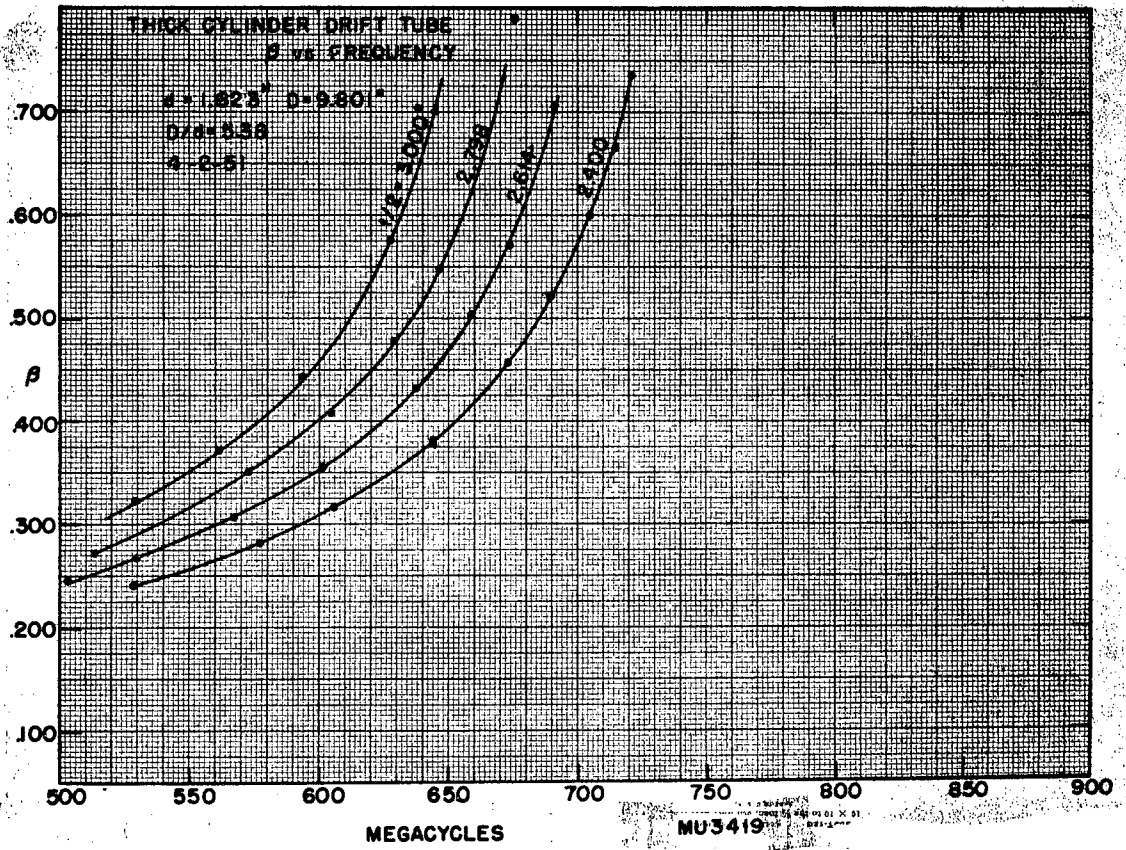

Fig. 14B

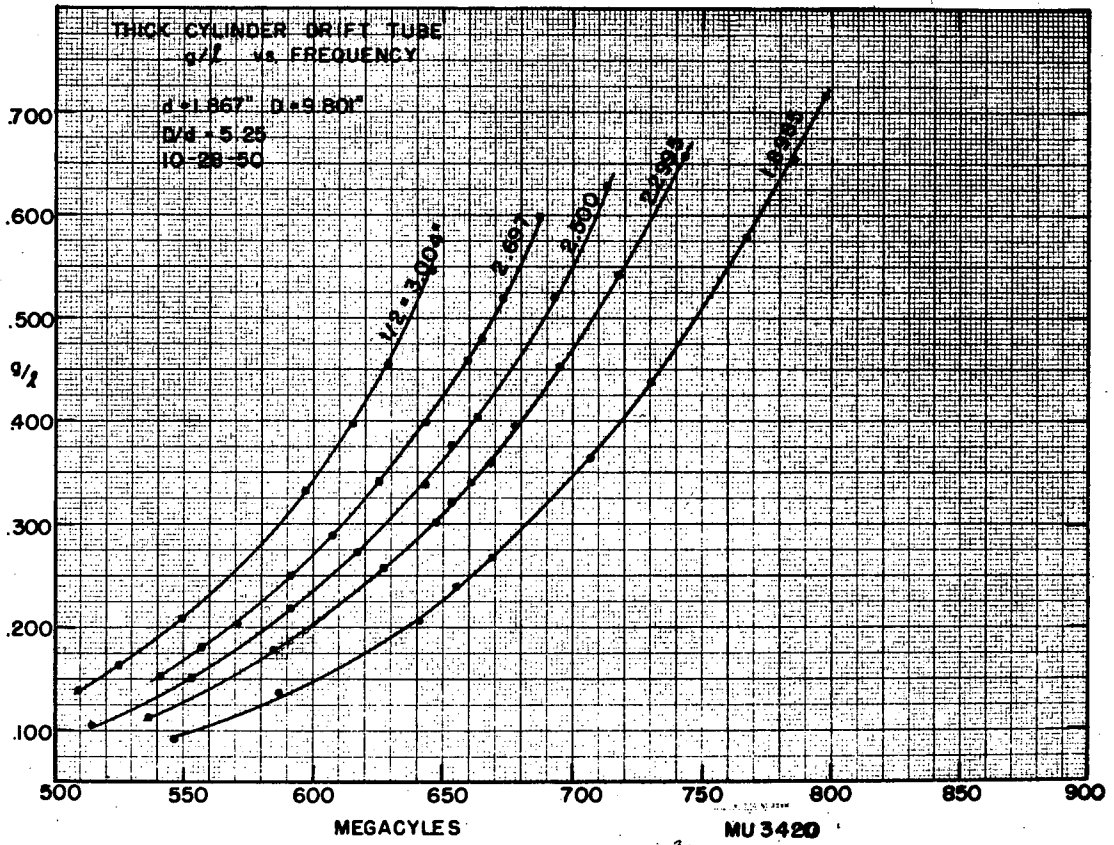

Fig. 15A

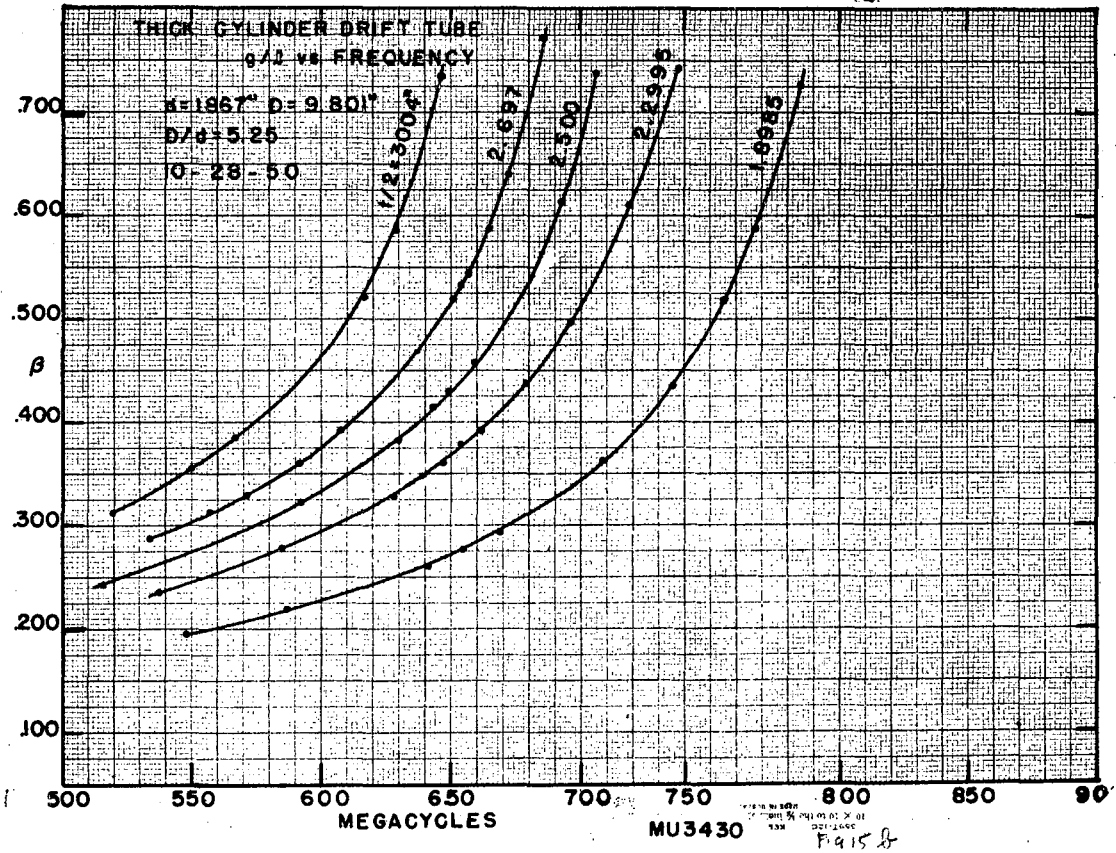

Fig. 15B

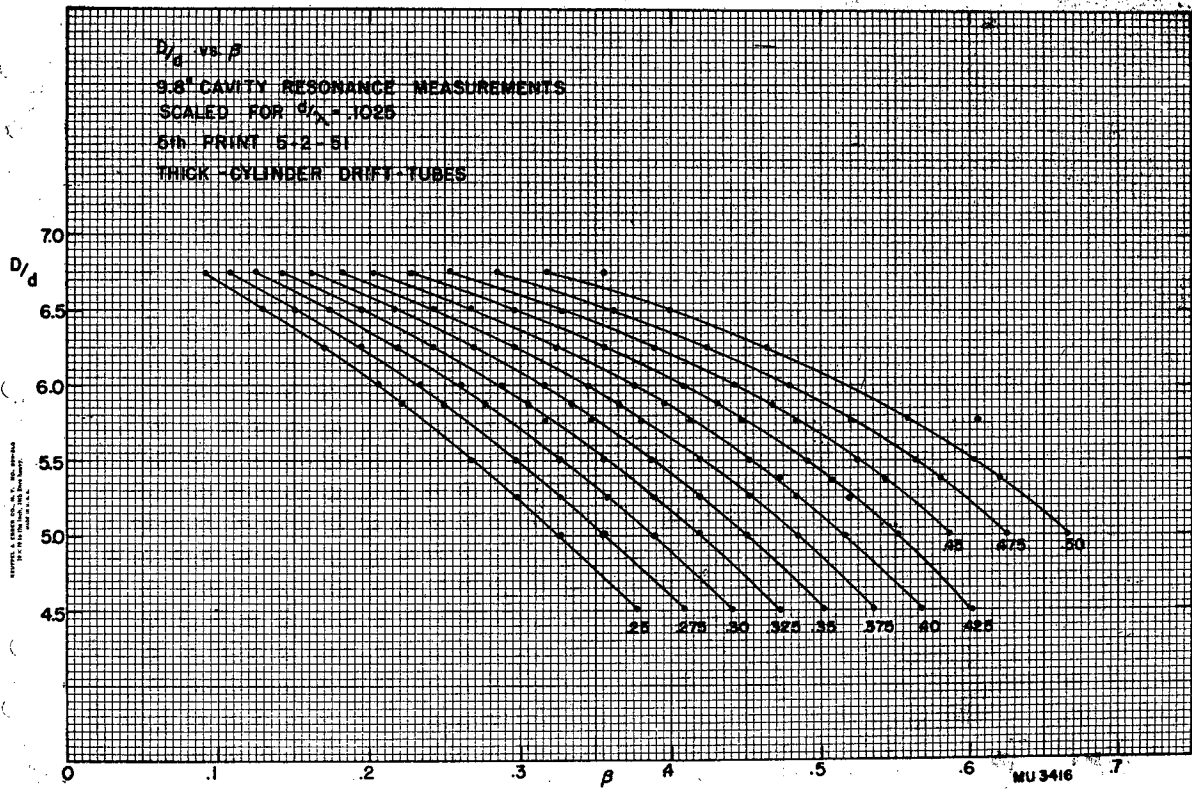

Fig. 16