

MARINE GEOPHYSICS: A NAVY SYMPOSIUM



MARINE GEOPHYSICS: A NAVY SYMPOSIUM

*in honor of
the 80th birthdays of
Russell W. Raitt and Victor Vacquier*

*and the 40th anniversary of
the Marine Physical Laboratory
of Scripps Institution of Oceanography
of the University of California San Diego*

*held on 16 October 1986
at Scripps Institution of Oceanography
La Jolla, California*

Edited by
Elizabeth N. Shor and Carolyn L. Ebrahimi

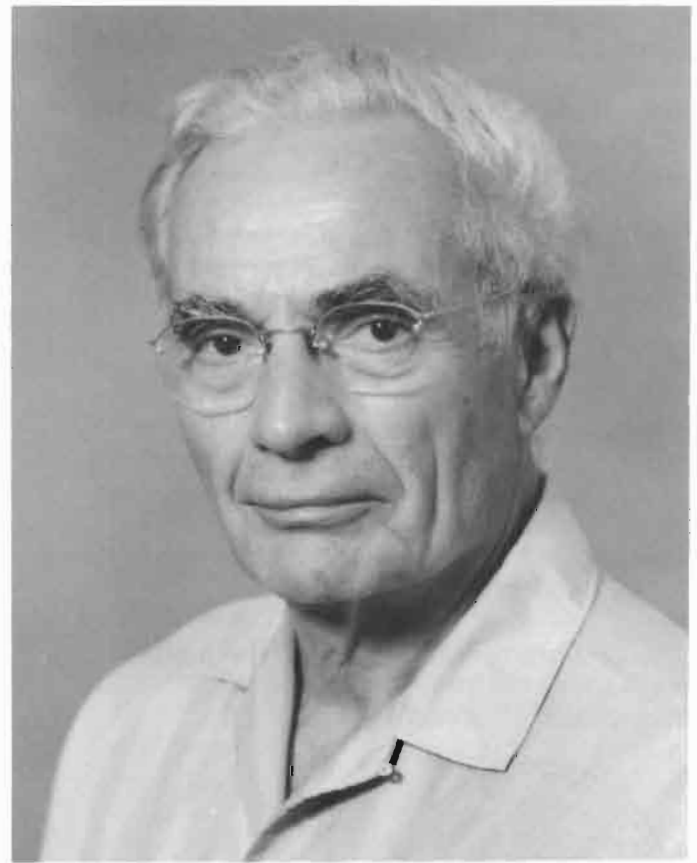
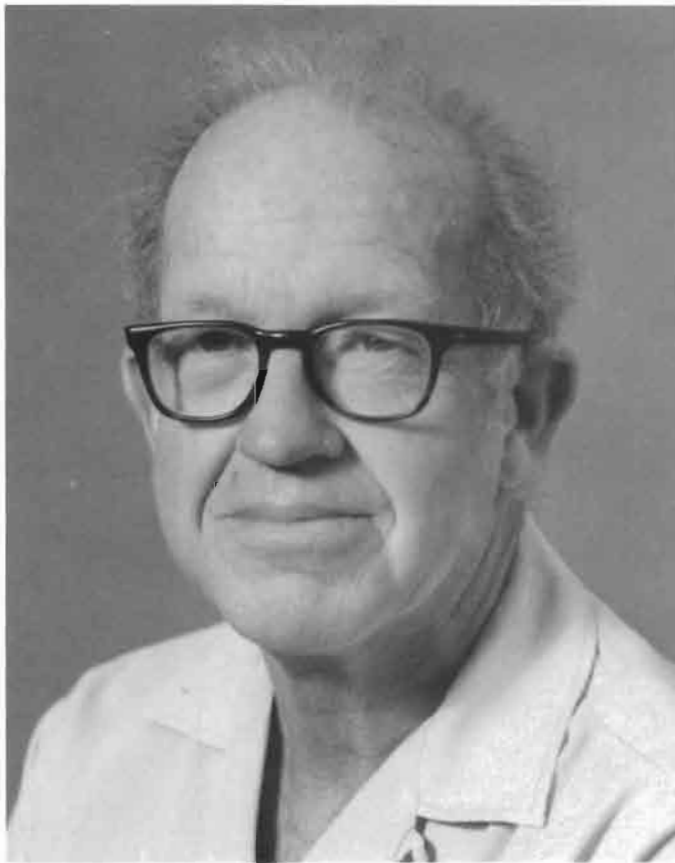

September 1987
Marine Physical Laboratory Report No. MPL-U-42/87

Published by the Marine Physical Laboratory,
Scripps Institution of Oceanography, San Diego,
California, 1987. Additional copies are available
from MPL at University of California, San Diego,
P001, San Diego, CA 92152.

Symposium convened by John G. Sclater and Gerald
B. Morris, and organized with the assistance of the
Office of Naval Research.

This work relates to Department of Navy Grant
N00014-87-G-0052 issued by the Office of Naval
Research. The United States Government has a
royalty-free license throughout the world in all
copyrightable material contained herein.

The editors are grateful to George G. Shor, Jr. for
advice and technical assistance; to Phil Rapp and
Larry McKinley for technical assistance; and to Russ
Raitt, Vic Vacquier, Alan Jones, and Dick Von
Herzen for photos. The cover photo was taken by
Bill Call, Scripps Photo Lab.

On the Cover: Russell Raitt and Victor Vacquier,
with friends and family members, outside the
Symposium, 16 October 1986.



TABLE OF CONTENTS

Welcome

Robert L. Fisher • 1

Forty Years of Oceanic Research, and an Appreciation of Russell W. Raitt and Victor Vacquier

John G. Sclater and Elizabeth N. Shor • 4

Bibliography of Russell W. Raitt • 16

Bibliography of Victor Vacquier • 18

Session I: Acoustic and Seismic Researches (honoring Russell Raitt) *Chairman: Gerald B. Morris*

ONR Programs and Efforts

Gerald B. Morris • 21

Drifting Acoustic Sensors

Victor C. Anderson • 27

Modeling Multi-bounce Phases in Marine Sediments

Donald V. Helmberger • 31

The Development of Seismic-refraction Techniques in the Southern California Borderland

R. M. Kieckhefer, B. J. Russell and A. S. Meltzer • 43

Session II: Researches in Magnetism (honoring Victor Vacquier) *Chairman: Christopher G.A. Harrison*

The Source of Marine Magnetic Anomalies

Christopher G.A. Harrison • 52

Principles of Operation and Applications of RF-driven SQUID Magnetometers in Paleomagnetism and Rock Magnetism

Michael D. Fuller • 61

TABLE OF CONTENTS

Session III: Researches in Tectonics (*honoring Raitt & Vacquier*)
Chairman: John G. Sclater

Heat Flow Off Sumatra
Lawrence A. Lawver and Patrick T. Taylor • 67

Marine Heat Flow and Sea-floor Tectonics
Richard P. Von Herzen • 77

**Paleomagnetism of Oriented Drill Core
from the Alaskan North Slope**
Susan L. Halgedahl and Richard D. Jarrard • 83

After-Dinner Remarks
Presiding: George G. Shor, Jr. • 90

*Also presented at the symposium but not available
for this volume were:*

Seamounts and Cable Measurements
Michael L. Richards

The Tectonics of Ridge Axes
Jean Francheteau

WELCOME

Robert L. Fisher

Scripps Institution of Oceanography
La Jolla, CA 92093

Today we are celebrating the 80th year, not 80th birthday, of each of two distinguished colleagues, who — more importantly for today — are warm and modest and delightful humans, and good friends to nearly everyone in this room: Russ Raitt and Vic Vacquier.

In my view a third friend is much in evidence: Bill Menard's latest book, *The Ocean of Truth*, became available in published and easily used form last week. It sets forth what many of us at Scripps Institution of Oceanography would call the true story of plate tectonics, and exposes its real roots. Both of these men figure prominently in Bill's story. It can be argued, Russ, that you are the hero of Bill's tale, and, as one who saw you firsthand for some months on long expeditions in the 1950s and early 60s, I can buy that view.



Victor Vacquier with Jean Francheteau from Paris.

This is indeed an impressive gathering of friends who are also professional colleagues, but there too are several family members who have come to share in celebration today. These include: Mihoko Vacquier, and Victor D. Vacquier (recording on video); and on Russ's side of the aisle: Martha and Chris

Harrison and their children, Alison and Dick Gist and Vickie, Craig Biddle and Sharon from Sacramento, and La Jolla's own Charles and Monique Biddle.

Russ Raitt's shipboard investigations, in post-Midpac years in large part accompanied by Alan Jones and the late Max Silverman, covered a very large part of the Pacific and most of the temperate Indian Ocean. As a participant in most of these up to Lusiad Expedition, I gained a tremendous respect for Russ's dedication, his tenacity and stamina, and his improvisational abilities. His work with that of George Shor and Tim Francis in the Indian Ocean has never been bettered in categorizing a major suite of tectonic features throughout an ocean. Others in this room more recently have mined these data; no one has shot better. For me, at least, the most fascinating results were those from the trenches, where all of us worked to the limits of our equipment and our luck to establish what every schoolboy now knows as obvious, and can clearly pronounce: "subduction."



Russ Raitt and Gerald B. Morris before opening of Symposium session.

Most of us at Scripps first knew of Vic Vacquier from his contributions at Gulf Research and Development Company, where he had invented the flux-gate magnetometer. After its wartime use in submarine detection, the technique was applied to airborne mapping. Vic co-authored GSA Memoir 47 (Vacquier, Steenland, Henderson, and Zietz, 1951): "Interpretation of aeromagnetic maps," the handbook and how-to-do-it publication on the subject. The instrument was modified for work at sea; it first surfaced at SIO when Edward Titus Miller of Lamont Geological Observatory installed an instrument on *Spencer F. Baird* for the Capricorn Expedition in the summer of 1952. This early experience led to *Pioneer* surveys by Ron Mason and Art Raff in the mid-1950s that discovered and established the magnetic anomaly lineation patterns off the western United States. These SIO data prompted the early, unfortunately-not-published explanation by Canadian Lawrence Morley — a sobering story most recently detailed in *Eos* (Morley, 1986).

At SIO from 1958 on, Vacquier helped develop a simplified version of the proton precession magnetometer for measuring total magnetic field. In the field he worked with Art Raff and Bob Warren to extend well westward the pattern of magnetic lineations off the west coast. In August 1963 Vic received AMSOC's "Albatross" for "displacing the seafloor by 700 kilometers"; later accounts for geophysicists list this figure as 1400 kilometers. Incidentally, this award ceremony represented a mere one-hour commute, from San Francisco. It became Vic's albatross in the poetic sense, too; he was enjoined to deliver it to Henry Stommel, at Tokyo, in 1966.

Since the early 1960s Vacquier has made and supervised hundreds of measurements of terrestrial heat flow in various oceans, in lakes such as Titicaca and Malawi, and in oil fields in Sumatra and Brazil. In this work he taught, and learned from, such people as Dick Von Herzen, John Sclater, Chuck Corry, and Pat Taylor.

A partial list of Vic Vacquier's honors includes the Wetherill Medal of the Franklin Institute (1960), AMSOC's Albatross (1963), AGU's John Adam Fleming Medal (1973) and SEG's Fessenden Medal (1975). At least two of these stemmed from his invention of the magnetic airborne detector and its impact on exploration, a third for contributions in several fields of observational geophysics, the fourth for — as Archimedes dreamed of doing — "moving the earth."

Others today will outline Vic's tremendous achievements, and show slides and tell sea stories about his many SIO activities. My warmest memories are of the early sixties: of Vacquier the tireless tourist going halfway along Java by jitney in the dead of night for a brief look at Bourabadour, or disappearing for several days in the Mauritian French culture on the beach at Le Morne Brabant, or standing beside me on *Argo* one night near Sunda Strait when we took her across the submerged crater lip of Krakatoa and watched volcanic ejecta the size of Volkswagens being hurled up from Anak Krakatoa not far from *Argo's* bow.

Shipboard times around the globe with such men as Russ and Vic are unforgettable. But now let's recognize their ongoing influences, as marked by these reports of geophysical colleagues who are also their warm admirers.

References

- Morley, L. W. 1986. Early work leading to the explanation of the geomagnetic imprinting of the ocean floor. *Eos Trans. AGU* 67: 665-666.
- Vacquier, V., Nelson Clarence Steenland, Roland G. Henderson, and Isidore Zietz. 1951. Interpretation of aeromagnetic maps. *Geol. Soc. Am. Memoir* 47:151 pp.



**FORTY YEARS OF OCEANIC RESEARCH, AND
AN APPRECIATION OF
RUSSELL W. RAITT AND VICTOR VACQUIER**

John G. Sclater*

*Institute for Geophysics
University of Texas at Austin
8701 Mopac Blvd.
Austin, TX 78759*

and

Elizabeth N. Shor

*2655 Ellentown Road
La Jolla, CA 92037*

Introduction

It is a great privilege to stand here in front of so many distinguished oceanographers to present an appreciation of MPL on its 40th birthday by honoring the work of two scientists for whom I have long had a high regard: Russell Raitt and Victor Vacquier.

It is especially gratifying to honor MPL on this occasion because I spent seven very rewarding years at the laboratory and have a deep appreciation and respect for the distinguished scientists who have directed it: Carl Eckart, Sir Charles Wright, Al Focke, Fred Spiess, and Ken Watson.

Today we recognize the research achievements of Russ and Vic.

Being a geologist by inclination but having had a classical physics education in Europe, I have always had a high regard for scientists who have made important observations that have stood the test of time. Russ and Vic are such scientists. What has struck me so much in reviewing their accomplishments is the fundamental understanding they have brought to our knowledge of the ocean floor by their careful observations and measurements, which form the central basis for the theory of sea-floor spreading.

They have both led remarkably interesting and productive careers. These involved an exciting and varied childhood, industrial and war research after graduate school and finally a long period of productive research at MPL and Scripps.

Both are seagoing observational scientists. Between them they have supervised about 20 Ph.D. students and directed the research of an equal number of post-docs. Most of these students and post-docs are still seagoing scientists. In fact, three of them — Larry Lawver, Roger Anderson, and John Hildebrand — could not be here today because they are at sea. In addition, many of these students and post-docs are now the current leaders in marine geology and geophysics, not only in the United States but also in Britain, France, and Australia.

*Speaker, so represents the first-person pronouns.

About Russ Raitt

Russell Watson Raitt was born in Philadelphia, Pennsylvania on September 30, 1907. His father was a minister in the United Presbyterian Church with responsibility for founding new churches. In 1921 Russ's parents moved to California, and Russ entered high school in Hollywood. He found it much more sophisticated than schools he had known before. In fact, his parents decided it was a den of iniquity and soon moved to South Pasadena, where Russ finished high school.*

In 1925 he entered the California Institute of Technology, partly because it was gaining a reputation as an excellent school under the new leadership of Robert A. Millikan, but mostly because it was nearby. There he was exposed to many outstanding teachers, such as Ira Bowen for sophomore physics, and Linus Pauling, who supervised a research project of Russ's in his junior year. He graduated in 1929 with a B.S. in physics, travelled in Europe, and then worked for Hercules Powder Company for two years.

Russ returned to Caltech for graduate work in 1931. His doctoral work, under Millikan, was to measure the radioactive content of a large number of dirt samples collected by Millikan and associates around the world in their study of cosmic rays. His dissertation was titled: "Direct measurement of Alpha particle activities of rocks and determination of thorium." Russ received his Ph.D. in 1935, and that same year he married Helen Hill, whom he had known in the South Pasadena high school. He acquired an instant family, Helen's three children by her first marriage. Russ and Helen's daughter Martha was born in 1939.**



Helen, her three children, and Russell Raitt, a few days after their marriage in 1935.

Also in 1935 Russ joined two Caltech geophysics graduates, Josh Soske and Raymond Peterson, in Geophysical Engineering Corporation, a company established to look for oil fields. Their first project was reflection prospecting in the Los Angeles basin. To interpret their reflection records, Russ had to obtain

*Some of this material is from a taped conversation among Raitt, G. Shor and E. Shor on 30 October 1984, which is the source of quoted comments by Raitt.

**She is the wife of Christopher G. A. Harrison.

velocity as a function of depth, and so he discovered that Beno Gutenberg had shot a long refraction profile across the Los Angeles basin about 1933, to measure the depth of alluvial fill. It provided him with what he called "a beautiful profile of the travel time versus distance which fit quite well to a linear velocity/depth function." The three-man field party also surveyed the Pasadena water basin for depth to the granite basement, and did refraction prospecting in the San Joaquin Valley. By 1941 the company was definitely declining. It had been "kind of fun," Russ said, "and I think we pioneered in some ways."

Having learned of a new laboratory being formed in San Diego, Russ visited it to talk to its director, Vern O. Knudsen from the physics department of UCLA. The new laboratory was the University of California Division of War Research, which Russ joined in the summer of 1941. Helen was quite delighted, as she had always enjoyed being at the beach.

Russ's work at UCDWR was in acoustics, using explosives and echo-ranging transducers to measure sound propagation and scattering in the water and reflections from the sea floor. The available ships were the *E. W. Scripps*, on loan from Scripps Institution of Oceanography, and the *Jasper*, a preempted yacht later owned by SIO as the *Stranger*. Carl Eckart was head of one of the two divisions of UCDWR, which included the echo-ranging section to which Russ belonged. Russ found him to be a "marvelous scientist...he had such a wonderful conception of what was important in every thing he did."

During 1942, Russ and colleagues observed the phantom bottom, which registered as if the sea floor was very shallow when it was known to be deep (Eyring, Christensen, and Raitt, 1948; Raitt, 1948). They concluded that this was not an instrument problem, and called it the Deep Scattering Layer because it scattered the sound waves. Biologist Martin W. Johnson suggested that the layer was composed of living organisms, and on a sea trip in June 1945 he followed its daily cycle through 24 hours.

UCDWR began to be dismantled during 1945, and the Navy Electronics Laboratory was established from it. However, Carl Eckart wanted a university affiliation; he almost gave up because of interminable delays. Russ hung on, having chosen not to transfer to NEL. And on July 1, 1946 the Marine Physical Laboratory of the University of California began operations. Its scientific staff members were: Carl Eckart, Director and Professor of Geophysics; Russell W. Raitt, Senior Research Associate; Robert W. Young, Research Associate; William C. Kellogg, Research Fellow (i.e., graduate student); Finn W. Outler, Marine Supervisor.

MPL was joined to SIO instead of the University of California at Berkeley in 1948, when Carl Eckart became director of both MPL and SIO. Russ became associate professor at SIO in 1949 and professor in 1956. He had begun teaching at SIO in 1947 a course in principles of underwater sound.

Russ's first research at MPL was a carryover from UCDWR: analyzing oscillograms of bottom echoes derived from vertical beams of 24-kc sound. He devised improved equipment and gathered more reflection records at sea off San Diego. Using the bottom surveys done by the geological group under Francis P. Shepard for UCDWR, he selected sites of specific sediments from rock to mud, and analyzed the records for the dependence of echo amplitude and form on bottom type, depth and topography. By 1948 he could say: "Observations of the reflection of ultrasonic sound from the sea bottom have been explained reasonably well by the hypothesis that the sound is diffusely scattered from the ocean bottom, or from a layer extending a few feet into the bottom" (MPL Quarterly Report, 1 Jan. - 31 Mar., 1948).

Early in 1948, Russ began reflection studies using explosives at sea, first on a 12-day trip to Erben Bank (800 miles west of San Diego), on which he recorded 132 shots from 1/2 pound to 5 pounds of TNT. By the middle of that year he was doing refraction studies with SOFAR detonators and 50-pound charges of TNT. He quickly learned that hydrophone motion was lessened by floating the hydrophone at nearly neutral buoyancy at depths of 100 to 200 feet. The TNT charges were fired from a motor whaleboat — when practical. "Only a small percentage of the time did weather conditions permit operating in the deep ocean beyond the continental slope" (MPL Quarterly Report, 1 Apr. - 30 June 1949). For that reason a number of shallow-water profiles were recorded in the lee of islands such as Guadalupe, Cedros, and the San Benitos.

SIO acquired *Paolina-T*, a former purse seiner, in 1948, and Russ began two-ship refraction profiling in the spring of 1949 with that ship as the shooter and the *EPCE(R):855* of NEL as the receiver. He shifted to slow-burning time fuse instead of electric detonators so that the shooting ship could travel at full speed. "It was found quite practicable to record 50 miles of profile, with shots about one mile apart, in an eight hour working day" (MPL Quarterly Report, 1 July - 30 Sept. 1949).

In the experimenting of that era, Russ's group tried various ways of measuring reflections from the sea floor. They used hydrophones built by others, and they tried making their own. They used the "snake" — a long plastic hose full of hydrophones devised by L. C. Paslay of Dallas, Texas. Russ thinks it may have been the first towed seismic array.

In August 1949 Russ participated in the project of Merle A. Tuve to determine the structure of the earth's crust down to tens of kilometers. Tuve's work was sponsored jointly by the Carnegie Institution of

Washington and the three-year-old Office of Naval Research. From the *Paolina-T* were fired six charges of 1200 pounds, six of 2400 pounds, and one of 600 pounds. MPL recorded these at 13 ocean stations while Tuve and associates recorded them at many land stations. As part of the same project Russ set up an ocean station to record a quarry blast on August 6, 1949 at Corona (California) that used 156,000 pounds of explosives.

In 1950 he participated in SIO's first postwar cruise, Midpac — the Mid-Pacific Expedition. He recorded some 1,200 miles of refraction profiles, including a reversed profile inside Kwajalein Lagoon and many reversed profiles inside Bikini Lagoon and on the flanks of the atoll (Raitt, 1954). From the blue-water profiles he was surprised to find the average sediment thickness of the Pacific Ocean basin very thin. More detailed analyses revealed a low-velocity layer apparently related to volcanic rocks, later called Layer 2.

On Capricorn Expedition in 1952 Russ recorded 2,542 nautical miles of profiles and experimented with larger charges up to 480 pounds of TNT (MPL Quarterly Report, 1 January - 31 March, 1953). All but four stations reached the Mohorovičić discontinuity. The estimate of sediment thickness was of the order of only 100 to 200 meters in many cases. In the Tonga Trench the sedimentary fill was no more than a few hundred meters, and there the Mohorovičić discontinuity was 10 to 15 kilometers deep; elsewhere it was 5 to 10 kilometers deep. The low-velocity layer was again identified on many of the records (MPL Quarterly Reports; Raitt, 1956; Raitt, 1957).

Helen joined Russ at Tonga for the last part of Capricorn Expedition, although she had not set out to do so. She recounted that trip in a popular account *Exploring the Deep Pacific* (1956, W. W. Norton) which was translated into several languages and sold worldwide.



Russ and Helen on Fiji during Capricorn Expedition, 1952. Photo by Richard Von Herzen.

Russ continued reflection and refraction studies in the borderland (Shor and Raitt, 1958a, 1958b; Shor, Raitt and McGowan, 1976) and, whenever possible, farther afield in the Pacific Ocean (Raitt and Fisher, 1962; Shor, Menard and Raitt, 1971) and eventually into the Indian Ocean (Francis and Raitt, 1967). He — and George Shor, who joined MPL to work with Russ in 1953 — tried new kinds of hydrophones, including ones on the bottom, towed streamers, and new techniques. But basically they stayed with the methods that Russ had devised in his early years, because they worked.

Over the years, others adopted the techniques. Although the instrumentation and procedures were described in two papers (Raitt, 1952; Shor, 1963), the spread of the methods was mostly through personal contact: by visitors to Scripps, and by people whom Russ talked to abroad and on their own ships. The



Top: Dale C. Krause (left) checking the echo sounder while Russ looks at a monitor seismic record; Mukluk Expedition, 1957. Photo by Alan Jones.

Center: Russ (in stern) transferring to *Hugh M. Smith* from *Baird*; Fanfare Expedition, 1959. Photo by Alan Jones.

Bottom: Launching a Jalbert kite-balloon to measure anisotropy, on Scan Expedition, 1969; (from left) Russ Raitt, Gerald Morris, George Shor, Helen Kirk, and Fred Stone. Photo by Alan Jones.

methods were adopted first by British and Soviet groups, then by the Japanese, and finally by geophysicists at Lamont and Woods Hole in preference to methods they themselves had developed.

A summary of the most important discoveries from these wide-ranging surveys was reported by Russ in *The Sea*, Volume 3 (Raitt, 1963): the small thickness of sediment in the ocean basins, and the widespread existence of Layer 2, the material just beneath the unconsolidated sediments, now known to be pillow basalts. Those who did refraction work in the Atlantic Ocean did not detect it, and so calculated excessive thicknesses of the sedimentary layer. Russ detected it early, and worked to determine its nature. In part he was lucky: Layer 2 was easier to detect in the Pacific, because the sediments are thinner on average there than in the Atlantic. In part, it was an unexpected benefit of a quirk in field procedure. Russ called for the small shots at close range at the shortest time intervals possible; he monitored the quietest hydrophone on a pen-and-ink recorder, and thereby obtained detailed data over the limited range in which Layer 2 appeared as a first arrival. Those researchers who waited to develop each photographic oscillogram before calling for the next shot (the standard procedure in industry) had longer intervals between shots and missed Layer 2.

Other significant observations by Russ through the years were the remarkable uniformity of velocity of the oceanic crust, the small variations in depth to the mantle, and the accidental discovery of the low mantle velocity beneath the East Pacific Rise. Russ's early work in the borderland and around Guadalupe Island provided the background for the site selection of the test holes and the location of the Experimental Mohole drilled by *CUSS I* in 1961. From that came finally a sample of Layer 2: stark blue basalt. Russ and Shor both served on the panel that chose a site near Hawaii for the not-yet-drilled Mohole.

Both of them were also drawn into the puzzling question raised by Harry Hess in 1964: why, in refraction data taken by Raitt and Shor near California and Hawaii, did the velocity of seismic waves within the mantle appear to be faster in an east-west direction than in a north-south one? The term is anisotropy, and measurement of this small difference with any reasonable precision requires an elaborate pattern of shooting and receiving, such that observations are distributed over at least one-half the arc of a circle 30 miles in radius. The definitive experiment that finally proved the existence of anisotropy of seismic velocity in the mantle involved five ships from four institutions on Show Expedition in 1966. Russ was still pursuing the phenomenon on Scan Expedition in 1969 when he broke his leg while boarding a longboat after a visit on the enigmatic island of Pitcairn. His doctoral student Gerald B. Morris completed the scientific program of that expedition after Russ was airlifted to Tahiti (Raitt, Shor, Francis and Morris, 1969).

Besides enjoying going to sea, Russ has always loved to travel, and he has combined these pleasures at every opportunity, which have included many tropical isles.

About Vic Vacquier

Victor [V.]* Vacquier was born in St. Petersburg, Russia, on October 13, 1907, his parents' only child. Both sides of his family were of French origin. His father, Victor Alfonse Vacquier, was a doctor. In Vic's early years an important family member was his maternal grandfather, Nicolas Isnard, an internationally known businessman involved in transportation and the oil business in southern Russia. During World War I this grandfather represented the Russian oil industry at the Imperial Ministry in St. Petersburg. Vic's father was a major serving as a doctor in the front lines.

After the revolution the family found it difficult to survive, and so decided to leave the country. In the winter of 1920 Vic's mother, Tatiana Isnard Vacquier,** a remarkably energetic woman, sold all of the family possessions. With this money the family was able to escape in the middle of winter across the Gulf of Finland. From there they got to France, where Vic completed the last three years of high school.

Then an American whom they had known in St. Petersburg befriended them: Charles R. Crane, heir to the plumbing company and an occasional emissary of President Woodrow Wilson. Through his efforts, Vic and his mother were able to move to the United States. Both of them enrolled in the University of Wisconsin, and both received degrees in 1927: his mother a Ph.D. in Romance languages and Vic a B.S. in electrical engineering. He continued in graduate work at the same university and obtained a M.S. in physics in 1928. He and his mother discovered that they were illegal aliens, but through Crane's manager got student visas and in 1929 became U. S. citizens.

*It was Russian custom for a son's middle name to be his father's first name, which would make Vic's middle name also Victor; he prefers not to use it.

**She much later wrote a novel (not yet published) about the post-revolution years in Russia.

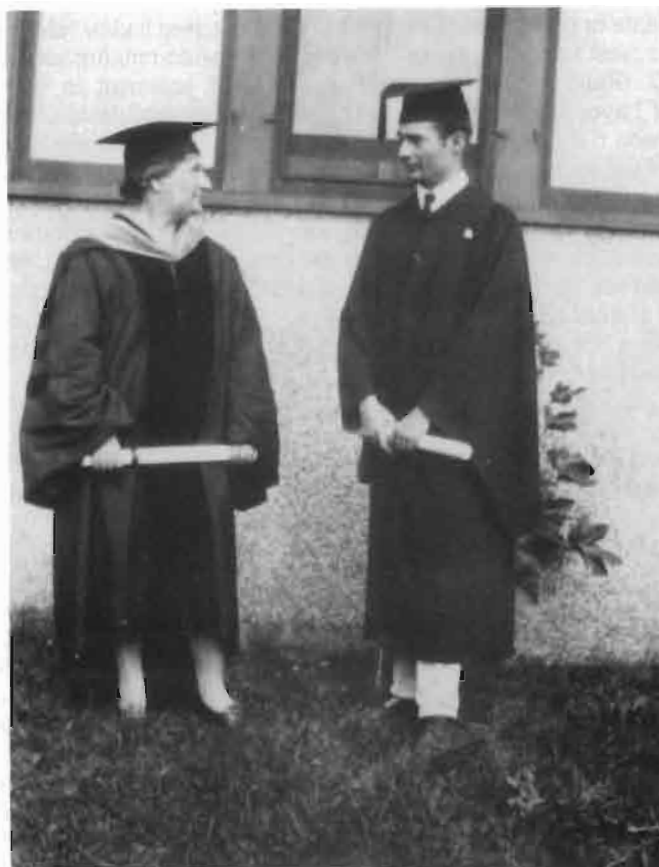

Victor Vacquier and his mother after receiving degrees from the University of Wisconsin, 1927.

At the invitation of his former professor, L. J. Peters, who had joined Gulf Oil Company, Vic went to work at the Gulf research laboratories in Pittsburgh in 1930. He married Vera Vinogradoff in 1931; their children were Vivian and Victor D. Vacquier.*

Vic's initial work at Gulf involved measuring and interpreting local and secular variations of the earth's magnetic field — a forerunner of magnetic-induction analysis. He soon began a project to find a magnetic method for orienting cores. However, while designing an instrument to measure the field of the very weakly magnetized samples, he developed a device that could measure the magnetic field very quickly and with a sensitivity a hundred times that of previous instruments. This device became known as the flux-gate magnetometer, one of his early patented devices (1946). When World War II began, Vic and his colleagues used the instrument to make better magnetic mines. However, by chance, while testing the mines, they found that the magnetometer was a remarkably good detector of submarines.

In 1942, Vic left Gulf for the Airborne Instruments Laboratory of Columbia University (located at Sperry Gyroscope Corporation), to oversee the development of a magnetic airborne detector. By 1944 they had an operational system that served very effectively to seal the Straits of Gibraltar to submarines — a spot where those vessels were very difficult to detect acoustically.

While located at Sperry Gyroscope, Vic was a dollar-a-year professor in Maurice Ewing's department at Columbia University. With graduate student Nelson Steenland and U. S. Geological Survey scientists Roland Henderson and Isidore Zietz, he wrote GSA Memoir 47, "Interpretation of Aeromagnetic Maps" (Vacquier, Steenland, Henderson, and Zietz, 1951). He says that he has never used the technique himself, but "they tell me this was the Bible on the subject before the computer age."

After the war the flux-gate magnetometer was developed for use in the oil industry by Gulf and became one of the standard survey tools. In addition it was modified for use at sea. In the early 1950s

*Vivian died in an auto accident in 1987; Victor is a professor of biology at SIO.



Vic with a Schmidt vertical field magnetic balance, for Gulf, early 1930's.

Ronald Mason and Art Raff at MPL and SIO began a series of magnetic surveys off the west coast of the United States. Raff and Max Silverman of SIO alternated trips on the U. S. Coast & Geodetic Survey ship *Pioneer* as it carried out a hydrographic survey off southern California on a series of precisely navigated east-west lines about five miles apart (Mason, 1958).

Meanwhile Vic had left the Columbia University laboratory to head a group at Sperry Corporation making gyro-compasses. His group developed the Mark 19 (patent by Braddon and Vacquier, 1957) and Mark 23 models. It is a tribute to Vic and Sperry that these compasses are still in use after 30 years.

The development of the gyro-compasses took more than six years, and then Vic looked for a job outside of industry where he would have more control over his own research. After visiting many universities to look over their research programs, he accepted a position in 1953 at the New Mexico Institute of Mining and Technology in Socorro. There he worked on exploring for fresh water in arid areas, and came up with a technique of using induced electrical polarization (Vacquier, Holmes, Kintzinger, and Lavergne, 1957). He also took an interest in the interpretation of the lineated magnetic anomalies found by Raff and Mason off the west coast. He continued his work for the Department of Defense and served on Project Nobska in 1956 that recommended the building of the *Polaris* submarines. When Walter Munk delivered a commencement address at the New Mexico Institute, Vic first became aware of the researches at Scripps Institution of Oceanography.

Vic's technique of searching for fresh water became the subject of a lecture series under the auspices of the Society of Exploration Geophysicists. He presented this talk at Scripps Institution, queried about a position, and in 1957 joined Scripps at the invitation of Roger Revelle. Vic took over the magnetic group at MPL as a research physicist. He became a professor at SIO in 1962, and taught a course in geomagnetism.

At Scripps, Vic relieved Raff on the *Pioneer*, then with Robert E. Warren he modified the proton precession magnetometer, working in the MPL workshop. Soon he went out on Scripps ships to extend the magnetic survey to the south and on a few lines much further to the west. He found that certain distinctive anomalies were repeated on the east-west profiles but that they were offset by 700 km. (Menard and Vacquier, 1958; Vacquier, 1959). This offset exactly aligned with a fracture zone in the northeastern

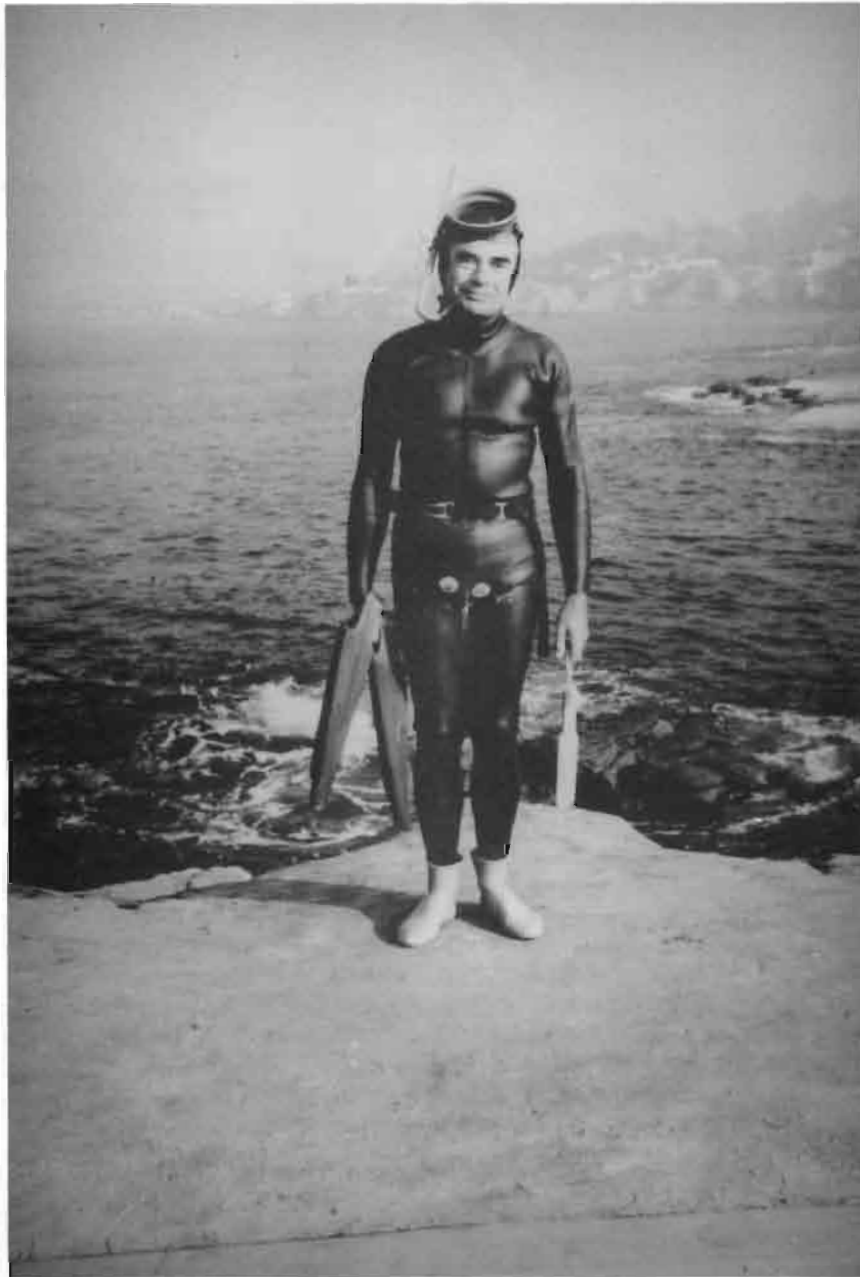

Vic at La Jolla Cove, 1958.

Pacific that Bill Menard had mapped (Menard, 1986). At that time, very few believed that the ocean floor could move, but before long Vic had even extended the offset to 1420 km. (Vacquier, Raff and Warren, 1961).

In addition to interpreting magnetic anomalies, Vic developed a method using the topography of and the magnetic field over a sea mount to determine the magnitude and direction of the magnetization vector (Vacquier, 1962). The program that he developed to carry out these computations had a colorful history. It was taken to England by Ronald Mason and used by one of his students, who lent it to Drummond

Matthews and Fred Vine. It was a critical factor in their famous paper (Vine and Matthews, 1963) that interpreted the cause of sea-floor magnetic anomalies, as they used Vic's program to demonstrate that the sea mounts they had surveyed on the magnetic anomalies over the ridge axis in the Indian Ocean had the same polarity as the magnetic stripes. It was this feature that convinced at least one reviewer of the merits of the paper.

When Richard Von Herzen left Scripps for a UNESCO post in Paris, Vic was persuaded to take over the heat-flow program at MPL, which followed the pioneering work of Roger Revelle, Art Maxwell, Dick Von Herzen and Seiya Uyeda. Harry Hess's concept of sea-floor spreading (Hess, 1962) had as its central piece of evidence the then recently published heat-flow profile across the East Pacific Rise (Von Herzen, 1959). It was Vic, together with Von Herzen, who showed that this correlation was true in the South Atlantic and the central Indian Ocean (Von Herzen and Vacquier, 1966). Vic's interest in heat flow continued until his retirement in 1975. It included studies in Lake Malawi in Africa (Vacquier and Von Herzen, 1967) and in Lake Titicaca in South America (Sclater, Vacquier and Rohrhirsch, 1970).

During his MPL years and since, Vic has developed: (a) a method for getting good heat-flow values out of bottom-hole temperature surveys carried out in producing oil fields; (b) an instrument to enable the rapid determination of the thermal conductivity of hard-rock cores; and (c) a method of estimating thermal conductivity from standard well-logging techniques. He is still working on this last project, having examined cores in Texas and having recently spent time at Institut Francais du Petrole in Paris working on cores and logs.

In 1966, while spending time at the Earthquake Research Institute in Japan after Zetes Expedition, Vic married Mihoko Wada, who was called to work for him at the institute as she knew both English and Russian. Mihoko is an accomplished artist.

For his researches, Vic has received: the Wetherill Medal of the Franklin Institute (1960), in recognition of the importance of the saturating core magnetometer and its development as a practical airborne magnetometer; the Albatross Award of the American Miscellaneous Society (1963) for suggesting that the ocean floor had moved hundreds of kilometers; the John Adam Fleming Medal of the American Geophysical Union (1973) for "original research and technical leadership in geomagnetism and other related sciences"; and the Fessenden Award of the Society of Exploration Geophysicists (1975) for "the invention of the airborne magnetometer."

Vic has always been modest about his own accomplishments. It has been and still is a pleasure to work with him because he is so approachable and willing to listen to the work of others. Of particular value to me has been his advice on the development and building of instruments.

In Conclusion

What has always impressed me about Russ and Vic is that, in addition to their scientific competence, they have always been so energetic and enthusiastic about the work they were doing. Their interest in going to sea, their ability to do high-quality work and to make it fun both for themselves and for others was the keystone of the success of the marine geology and geophysics program at Scripps. They, with Bob Fisher, Bill Menard, George Shor, Harmon Craig, Ed Goldberg, Fred Spiess and others, made Scripps famous as a research institution in that marine program. The quality of work that these scientists were doing at sea, their openness and the freedom with which the post-docs and students were treated are among the factors that made Scripps such an exciting place for research on the ocean floor. They are also the major reason that their students were so successful later in capitalizing on the advances to be made by interpreting marine data within the concepts of sea-floor spreading and plate tectonics.

Looking into Vic's and Russ's lives has also taught me that research can be fun and vigorous after the age of forty, and that it is possible to have an active and productive research career into one's sixties — especially if one remains an active sea-going oceanographer.

Vic going native in Tahiti, 1959.



Vic on a typical day at sea.



References

- Eyring, C. F., R. J. Christensen, and R. W. Raitt. 1948. Reverberation in the sea. *J. Acoust. Soc. Am.* 20:462-475.
- Francis, T. J. G., and R. W. Raitt. 1967. Seismic refraction measurements in the southern Indian Ocean. *J. Geophys. Res.* 72:3015-3041.
- Hess, H. H. 1962. History of ocean basins, in *Petrologic Studies: A volume to honor A. F. Buddington*, edited by Engel, James and Leonard, pp. 599-620. Geol. Soc. Am.
- Mason, R. G. 1958. A magnetic survey off the west coast of the United States, *Geophys. J.* 1:320-329.
- Menard, H. W. 1986. *The Ocean of Truth*. Princeton University Press.
- Menard, H. W., and V. Vacquier. 1958. Magnetic survey of part of the deep sea floor off the coast of California. *Res. Rev.* (June):1-5.
- Raitt, R. W. 1948. Sound scatterers in the sea. *J. Mar. Res.* 7:393-409.
- Raitt, R. W. 1952. Geophysical measurements. *Symposium on Oceanographic Instrumentation*, pp. 70-84. Office of Naval Research.
- Raitt, R. W. 1954. Seismic refraction studies of Bikini and Kwajalein atolls. *U.S. Geol. Surv. Prof. Paper* 260-K:507-527.
- Raitt, R. W. 1956. Seismic-refraction studies of the Pacific Ocean basin, part I, Crustal thickness of the central equatorial Pacific. *Bull. Geol. Soc. Am.* 67:1623-1639.
- Raitt, R. W. 1957. Seismic refraction studies of Eniwetok Atoll, *U.S. Geol. Surv. Prof. Paper* 260-S:685-698.
- Raitt, R. W. 1963. The crustal rocks, in *The Sea, Ideas and Observations on Progress in the Study of the Seas*, Vol. 3, Chap. 5, edited by M. N. Hill, pp. 85-109. Interscience.
- Raitt, R. W., and R. L. Fisher. 1962. Topography and structure of the Peru-Chile Trench. *Deep-Sea Res.* 9:423-443.
- Raitt, R. W., G. G. Shor, Jr., T. J. G. Francis, and G. B. Morris. 1969. Anisotropy of the Pacific upper mantle. *J. Geophys. Res.* 74:3095-3109.
- Slater, J. G., V. Vacquier, and J. H. Rohrhirsch. 1970. Terrestrial heat flow measurements on Lake Titicaca, Peru. *Earth Planet. Sci. Letts.* 8:45-54.
- Shor, G. G., Jr. 1963. Refraction and reflection techniques and procedure. In *The Sea, Ideas and Observations on Progress in the Study of the Seas*, vol. 3, chap. 2, edited by M. N. Hill, pp. 20-38. Interscience.
- Shor, G. G., Jr., H. W. Menard, and R. W. Raitt. 1971. Structure of the Pacific basin. In *The Sea, Ideas and Observations on the Progress in the Study of the Seas*, Vol. 4, Part II, edited by A. E. Maxwell, pp. 3-27. Wiley-Interscience.
- Shor, G. G., Jr., and R. W. Raitt. 1958a. Seismic studies in the southern California continental borderland. *SIO Reference* 58-78:19 pp.
- Shor, G. G., Jr., and R. W. Raitt. 1958b. Seismic studies in the southern California continental borderland. *Intern. Geological Congress*, 20th Session, Section 9, 2nd volume:243-259.
- Shor, G. G., Jr., R. W. Raitt, and D. D. McGowan. 1976. Seismic refraction studies in the southern California borderland, 1949-1974. *SIO Reference* 76-13:71 pp.
- Vacquier, V. 1959. Measurement of horizontal displacement along faults in the ocean floor. *Nature* 183:452-453.
- Vacquier, V. 1962. A machine method for computing the magnitude and the direction of magnetization of a uniformly magnetized body from its shape and a magnetic survey. *Benedum Earth Magnetism Symposium*, edited by T. Nagata, pp. 123-127. Univ. Pittsburgh Press.
- Vacquier, V., C. R. Holmes, P. R. Kintzinger and M. Lavergne. 1957. Prospecting for ground water by induced electrical polarization. *Geophysics* 22:660-687.
- Vacquier, V., A. D. Raff and R. E. Warren. 1961. Horizontal displacements in the floor of the Pacific Ocean. *Bull. Geol. Soc. Am.* 72:1251-1258.
- Vacquier, V., N. C. Steenland, R. G. Henderson and I. Zietz. 1951. Interpretation of aeromagnetic maps. *Geol. Soc. Am. Memoir* 47:151 pp.
- Vacquier, V., and R. Von Herzen. 1967. Terrestrial heat flow in Lake Malawi, Africa. *J. Geophys. Res.* 72:4221-4226.
- Vine, F. J., and D. H. Matthews. 1963. Magnetic anomalies over oceanic ridges. *Nature* 199:947-949.
- Von Herzen, R. P. 1959. Heat-flow values from the southeastern Pacific. *Nature* 183:882-883.
- Von Herzen, R. P., and V. Vacquier. 1966. Heat flow and magnetic profiles on the mid-Indian Ocean Ridge. *Phil. Trans. Roy. Soc.* A259:262-270.

BIBLIOGRAPHY

Russell W. Raitt

-
- Eyring, C. F., R. J. Christensen, and R. W. Raitt. 1948. Reverberation in the sea. *J. Acoust. Soc. Am.* 20:462-475.
- Raitt, R. W. 1948. Sound scatterers in the sea. *J. Mar. Res.* 7:393-409.
- Raitt, R. W. 1952a. The 1950 seismic refraction studies of Bikini and Kwajalein atolls and Sylvania Guyot. *SIO Reference* 52-38:40 pp.
- Raitt, R. W. 1952b. Geophysical measurements. *Symposium on Oceanographic Instrumentation*, pp. 70-84. Office of Naval Research.
- Raitt, R. W. 1954. Seismic refraction studies of Bikini and Kwajalein atolls. *U.S. Geol. Surv. Prof. Paper* 260-K:507-527.
- Raitt, R. W., R. L. Fisher, and R. G. Mason. 1955. Tonga Trench. *Geol. Soc. Am. Special Paper* 62:237-254.
- Raitt, R. W. 1956. Seismic-refraction studies of the Pacific Ocean basin, part I, Crustal thickness of the central equatorial Pacific. *Bull. Geol. Soc. Am.* 67:1623-1639.
- Raitt, R. W. 1957. Seismic refraction studies of Eniwetok Atoll, *U.S. Geol. Surv. Prof. Paper* 260-S:685-698.
- Shor, G. G., Jr., and R. W. Raitt. 1958a. Seismic studies in the southern California continental borderland. *SIO Reference* 58-78:19 pp.
- Shor, G. G., Jr., and R. W. Raitt. 1958b. Seismic studies in the southern California continental borderland. *Intern. Geological Congress*, 20th Session, Section 9, 2nd volume:243-259.
- Fry, J. C., and R. W. Raitt. 1961. Sound velocities at the surface of deep sea sediments. *J. Geophys. Res.* 66:589-597.
- Raitt, R. W., and R. L. Fisher. 1962. Topography and structure of the Peru-Chile Trench. *Deep-Sea Res.* 9:423-443.
- Northrop, J., and R. W. Raitt. 1963. Seaquakes in the Flores Sea. *Bull. Seism. Soc. Am.* 53:577-583.
- Raitt, R. W. 1963. The crustal rocks, in *The Sea, Ideas and Observations on Progress in the Study of the Seas*, Vol. 3, Chap. 5, edited by M. N. Hill, pp. 85-109. Interscience.
- Raitt, R. W. 1964. Geophysics of the South Pacific. *Research in Geophysics* 2:223-241.
- Francis, T. J. G., and R. W. Raitt. 1967. Seismic refraction measurements in the southern Indian Ocean. *J. Geophys. Res.* 72:3015-3041.
- Raitt, R. W., G. G. Shor, Jr., T. J. G. Francis, and G. B. Morris. 1967. Anisotropy of the Pacific upper mantle. *SIO Reference* 67-8:44 pp.
- Raitt, R. W., G. G. Shor, Jr., T. J. G. Francis, and G. B. Morris. 1969. Anisotropy of the Pacific upper mantle. *J. Geophys. Res.* 74:3095-3109.
- Morris, G. B., R. W. Raitt, and G. G. Shor, Jr. 1969. Velocity anisotropy and delay-time maps of the mantle near Hawaii. *J. Geophys. Res.* 74:4300-4316.
- Shor, G. G., Jr., and R. W. Raitt. 1969. Explosion seismic refraction studies of the crust and upper mantle in the Pacific and Indian oceans. In *The Earth's Crust and Upper Mantle*, edited by P. J. Hart, Geophysical Monograph No. 13, pp. 225-230. Am. Geophys. Union.
- Raitt, R. W. 1969. Anisotropy of the upper mantle. In *The Earth's Crust and Upper Mantle*, edited by P. J. Hart, Geophysical Monograph No. 13, pp. 250-256. Am. Geophys. Union.
- Shor, G. G., Jr., H. W. Menard, and R. W. Raitt. 1971. Structure of the Pacific basin. In *The Sea, Ideas and Observations on the Progress in the Study of the Seas*, Vol. 4, Part II, edited by A. E. Maxwell, pp. 3-27. Wiley-Interscience.
- Raitt, R. W., G. G. Shor, Jr., G. B. Morris, and H. K. Kirk. 1971. Mantle anisotropy in the Pacific Ocean. *Tectonophysics* 12:173-186.

- Moore, D. G., J. R. Curray, R. W. Raitt, and F. J. Emmel. 1974. Stratigraphic-seismic section correlations and implications to Bengal Fan history. *Initial Reports Deep Sea Drilling Project* 22:403-412.
- Rosendahl, B. R., R. W. Raitt, L. M. Dorman, L. D. Bibee, D. M. Hussong, and G. H. Sutton. 1976. Evolution of oceanic crust: I. A physical model of the East Pacific Rise crest derived from seismic refraction data. *J. Geophys. Res.* 81:5294-5304.
- Shor, G. G., Jr., R. W. Raitt, and D. D. McGowan. 1976. Seismic refraction studies in the southern California borderland, 1949-1974. *SIO Reference* 76-13:71 pp.
- Curray, J. R., G. G. Shor, Jr., R. W. Raitt, and M. Henry. 1977. Seismic refraction and reflection studies of crustal structure of the eastern Sunda and western Banda arcs. *J. Geophys. Res.* 82:2479-2489.
- Curray, J. R., D. G. Moore, L. A. Lawver, F. J. Emmel, R. W. Raitt, M. Henry, and R. Kieckhefer. 1979. Tectonics of the Andaman Sea and Burma. *Am. Assoc. Petrol. Geol. Memoir* 29:189-198.
- McCaffrey, R., E. A. Silver, and R. W. Raitt. 1980. Crustal structure of the Molucca Sea collision zone, Indonesia. In *The Tectonic and Geologic Evolution of Southeast Asian Seas and Islands*, Geophysical Monograph No. 23:161-177. Am. Geophys. Union.
- Curray, J. R., F. J. Emmel, D. G. Moore, and R. W. Raitt. 1982. Structure, tectonics, and geological history of the northeastern Indian Ocean. In *The Oceans, Basins and Margins*, 6, edited by E. M. N. Alan and F. G. Stehli, pp. 399-450. Plenum.

Patent

- Transducing system. 1947. U.S. 2,418,953.

BIBLIOGRAPHY

Victor V. Vacquier

-
- Vacquier, V. 1937a. Short-time magnetic fluctuations of local character. *Terr. Mag. and Atmos. Elec.* 42:17-28.
- Vacquier, V. 1937b. Ultimate precision of barometric surveying. *Bull. Am. Assoc. Petrol. Geol.* 21:1168-1181.
- Vacquier, V. 1938. Application of vertical variometer-measurements to the study of secular magnetic variations. *Trans. Am. Geophys. Union* 19:206-210.
- Vacquier, V. 1939a. A proposed geophysical method for orienting cores. *Geophysics* 4:292-299.
- Vacquier, V. 1939b. The base-line drift of Schmidt vertical magnetic field balances. *Trans. Am. Geophys. Union* 20:377-382.
- Vacquier, V. 1941. Results of magnetic detection tests of submarine S-48 from PBV plane on October 21, 1941. Gulf Res. and Devel. Co. Contract Report.
- Vacquier, V., and W. E. Tolles. 1941. Compensation of magnetic fields in MAD-equipped aircraft. OSRD Division 6, Rept. #4187.
- Vacquier, V., and J. Affleck. 1941. A computation of the average depth to the bottom of the earth's magnetic crust, based on a statistical study of local magnetic anomalies. *Trans. Am. Geophys. Union* 22:446-450.
- Vacquier, V. 1945. The Gulf absolute magnetometer. *Terr. Mag. and Atmos. Elec.* 50:91-104.
- Vacquier, V., R. F. Simons, and A. W. Hull. 1947. A magnetic airborne detector employing magnetically controlled gyroscopic stabilization. *Rev. Sci. Instr.* 18:483-487.
- Vacquier, V., N. C. Steenland, R. G. Henderson and I. Zietz. 1951. Interpretation of aeromagnetic maps. *Geol. Soc. Am. Memoir* 47:151 pp.
- Vacquier, V., P. R. Kintzinger, C. R. Holmes and R. H. Frische. 1956. Prospecting for ground water by induced electrical polarization. New Mexico Inst. Mining and Tech., Res. and Develop. Div.:41 pp.
- Vacquier, V., C. R. Holmes, P. R. Kintzinger and M. Lavergne. 1957. Prospecting for ground water by induced electrical polarization. *Geophysics* 22:660-687.
- Menard, H. W., and V. Vacquier. 1958. Magnetic survey of part of the deep sea floor off the coast of California. *Res. Rev.* (June):1-5.
- Vacquier, V. 1959. Measurement of horizontal displacement along faults in the ocean floor. *Nature* 183:452-453.
- Vacquier, V., and R. E. Warren. 1961. A ship-towed proton magnetometer. *Mar. Phys. Lab. Tech. Memo* TM-120:42 pp.
- Vacquier, V., and J. Belshe. 1961. Palaeomagnetism of deep sea cores. *Mar. Phys. Lab. Tech. Memo* TM-122:4 pp.
- Vacquier, V., A. D. Raff and R. E. Warren. 1961. Horizontal displacements in the floor of the Pacific Ocean. *Bull. Geol. Soc. Am.* 72:1251-1258.
- Vacquier, V. 1962a. Magnetic evidence for horizontal displacements in the floor of the Pacific Ocean. In *Continental Drift*, edited by S. K. Runcorn, pp. 135-144. Academic Press.
- Vacquier, V. 1962b. A machine method for computing the magnitude and the direction of magnetization of a uniformly magnetized body from its shape and a magnetic survey. *Benedum Earth Magnetism Symposium*, edited by T. Nagata, pp. 123-127. Univ. Pittsburgh Press.
- Vacquier, V., and R. P. Von Herzen. 1964. Evidence for connection between heat flow and the Mid-Atlantic Ridge magnetic anomaly. *J. Geophys. Res.* 69:1093-1101.
- Vacquier, V. 1965. Transcurrent faulting in the ocean floor. *Phil. Trans. Roy. Soc.* A258:77-82.

- Von Herzen, R. P., and V. Vacquier. 1966. Heat flow and magnetic profiles on the mid-Indian Ocean Ridge. *Phil. Trans. Roy. Soc.* A259:262-270.
- Vacquier, V., and P. T. Taylor. 1966. Geothermal and magnetic survey off the coast of Sumatra. *Bull. Earthquake Res. Inst.* 44:531-540.
- Vacquier, V., S. Uyeda, M. Yasui, J. Sclater, C. Corry, and T. Watanabe. 1966. Studies of the thermal state of the earth. *Bull. Earthquake Res. Inst.* 44:1519-1535.
- Vacquier, V., S. Uyeda, M. Yasui, J. G. Sclater, T. Watanabe, and C. E. Corry. 1967. Heat flow measurements in the northwestern Pacific. *Bull. Earthquake Res. Inst.* 44:375-393.
- Vacquier, V., and R. Von Herzen. 1967. Terrestrial heat flow in Lake Malawi, Africa. *J. Geophys. Res.* 72:4221-4226.
- Vacquier, V., M. L. Richards, and G. D. VanVoorhis. 1967. Calculation of the magnetization of uplifts from combining topographic and magnetic surveys. *Geophysics* 32:678-707.
- Vacquier, V., J. G. Sclater, and C. E. Corry. 1967. Studies of the thermal state of the earth. *Bull. Earthquake Res. Inst.* 45:375-393.
- Vacquier, V., S. Uyeda, M. Yasui, J. Sclater, T. Sato, J. Lawson, T. Watanabe, F. Dixon, E. Silver, U. Fukao, K. Sudo, M. Nishikawa, and T. Tanaka. 1967. Results of geomagnetic survey during the cruise of R/V ARGO in Western Pacific 1966 and the compilation of magnetic charts of the same area. *Bull. Earthquake Res. Inst.* 45:799-814.
- Vacquier, V., and S. Uyeda. 1967. Palaeomagnetism of nine seamounts in the western Pacific and of three volcanoes in Japan. *Bull. Earthquake Res. Inst.* 45:815-848.
- Harrison, C. G. A., V. Vacquier, and M. L. Richards. 1967. Palaeomagnetism of submarine igneous rocks. In *International Dictionary of Geophysics*, Vol. 2, edited by S. K. Runcorn:1157-1163. Pergamon Press.
- Corry, C., C. Dubois, and V. Vacquier. 1968. Instrument for measuring terrestrial heat flow through the ocean floor. *J. Mar. Res.* 26:165-177.
- Uyeda, S., and V. Vacquier. 1968. Geothermal and geomagnetic data in and around the island arc of Japan. In *The Crust and Upper Mantle of the Pacific Area*, edited by L. Knopoff, C. L. Drake, and P. J. Hart, Geophysical Monograph No. 12, pp. 349-366. Am. Geophys. Union.
- Sclater, J. G., V. Vacquier, and C. E. Corry. 1969. In situ measurement of the thermal conductivity of ocean-floor sediments. *J. Geophys. Res.* 74:1070-1081.
- Warren, R. E., V. Vacquier, J. G. Sclater, and R. F. Roy. 1969. A comparison of terrestrial heat flow and transient geomagnetic fluctuations in the southwestern United States. *Geophysics* 34:463-478.
- Vacquier, V. 1969. Magnetic intensity field in the Pacific. In *The Earth's Crust and Upper Mantle*, edited by P. J. Hart, Geophysical Monograph 13, pp. 422-430. Am. Geophys. Union.
- Sclater, J. G., V. Vacquier, and J. H. Rohrhirsch. 1970. Terrestrial heat flow measurements on Lake Titicaca, Peru. *Earth Planet. Sci. Letts.* 8:45-54.
- Vacquier, V. 1972. *Geomagnetism in Marine Geology*. Elsevier Pub. Co. 185 pp.
- Vacquier, V., S. Uyeda, and A. M. Jessop. 1972. Geothermal problems. *Earth Sci. Rev.* 8:243-245.
- Vacquier, V., and R. E. Whiteman. 1973. Measurement of fault displacement by optical parallax. *J. Geophys. Res.* 78:858-865.
- Harrison, C. G. A., R. D. Jarrard, V. Vacquier, and R. L. Larson. 1975. Palaeomagnetism of Cretaceous Pacific seamounts. *Geophys. J. Roy. Astr. Soc.* 42:859-882.
- Anderson, R. N., M. G. Langseth, V. Vacquier, and J. Francheteau. 1976. New terrestrial heat flow measurements on the Nazca Plate. *Earth Planet. Sci. Letts.* 29:243-254.
- Lawver, L. A., and V. Vacquier. 1977. Heat flow in the Sunda transect. *Eos Trans. AGU* 58:1233.
- Vacquier, V., and H. Carvalho deSilva. 1977. Method for determining terrestrial heat flow in oil fields. *Geophysics* 42:584-593.
- Carvalho, H., Purwoko, Siswoyo, M. Thamrin, and V. Vacquier. 1980. Terrestrial heat flow in the Tertiary basin of central Sumatra. *Tectonophysics* 69:163-188.
- Vacquier, V. 1984. Oil fields-A source of heat flow. *Tectonophysics* 103:81-98.
- Vacquier, V. 1985. The measurement of thermal conductivity of solids with a transient linear heat source on the plane surface of a poorly conducting body. *Earth Planet. Sci. Letts.* 74:275-279.
- Vacquier, V. *et al.* Calculations of terrestrial heat flow from oil well logging records. Submitted to *Bull. Am. Assoc. Petr. Geol.*

Patents

- Vacquier, V. V. 1938. Rock sampling method. U.S. 2,140,097.
- Vacquier, V. V. 1939. Apparatus for and method of measuring the terrestrial magnetic field. U.S. 2,151,627.
- Rusler, G. W., and V. V. Vacquier. 1940. Formation tester. U.S. 2,218,155.
- Vacquier, V. V. 1942. Apparatus for logging bores. U.S. 2,281,960.
- Vacquier, V. V. 1946. Apparatus for responding to magnetic fields. U.S. 2,406,870.
- Vacquier, V. V. 1946. Apparatus for responding to magnetic fields. U.S. 2,407,202.
- Vacquier, V. 1951. Method and apparatus for measuring the values of magnetic fields. U.S. 2,555,209.
- Vacquier, V., and J. N. Adkins. 1952. Directional indicator system. U.S. 2,605,341.
- Braddon, F. D., L. F. Beach, L. J. Delanty, and V. Vacquier. 1952. Marine gyro vertical. U.S. 2,598,672.
- Wu, W. I. L., and V. V. Vacquier. 1953. Conversion system. U.S. 2,634,393.
- Vacquier, V., and G. Moffly. 1955. Method of geophysical prospecting. Canada 511,207.
- Vacquier, V., A. P. Cope, and R. Proskauer. 1956. Control systems for gyroscopic instruments. U.S. 2,729,108.
- Braddon, F. D., and V. Vacquier. 1957. Gyroscopic direction-indicating instruments. U.S. 2,811,785.
- Vacquier, V. 1958. Gyro verticals. U.S. 2,835,132.
- Vacquier, V., and R. B. Blizzard. 1958. Navigating systems for dirigible craft. U.S. 2,835,131.
- Blizard, R. B., R. Proskauer, and V. Vacquier. 1960. Sonar ray tracer. U.S. 2,942,782.
- Dunbar, L. E., and V. Vacquier. 1961. Accelerometer. U.S. 2,968,950.
- Vacquier, V. 1961. Automatic depth control system. U.S. 2,969,033.

ONR PROGRAMS AND EFFORTS

Gerald B. Morris*

*Head, Office of Naval Research Detachment
Bay St. Louis
NSTL, MS 39529*

We are here today not only to celebrate the fortieth birthday of the Marine Physical Laboratory but also to honor the research efforts and contributions that two of MPL's premier scientists, Russell Raitt and Victor Vacquier, have made.

What I would like to do, however, is dedicate my comments to the younger, in age but not in enthusiasm, Russell Raitt and Victor Vacquier, in the hope that what I can tell them about the Office of Naval Research will help them understand the organization, its programs, and perhaps encourage them to utilize this source of funding to pursue research of interest to the Navy in the future. I will start with a programmatic presentation; after all, if you scratch a program manager, you're going to get a program presentation.

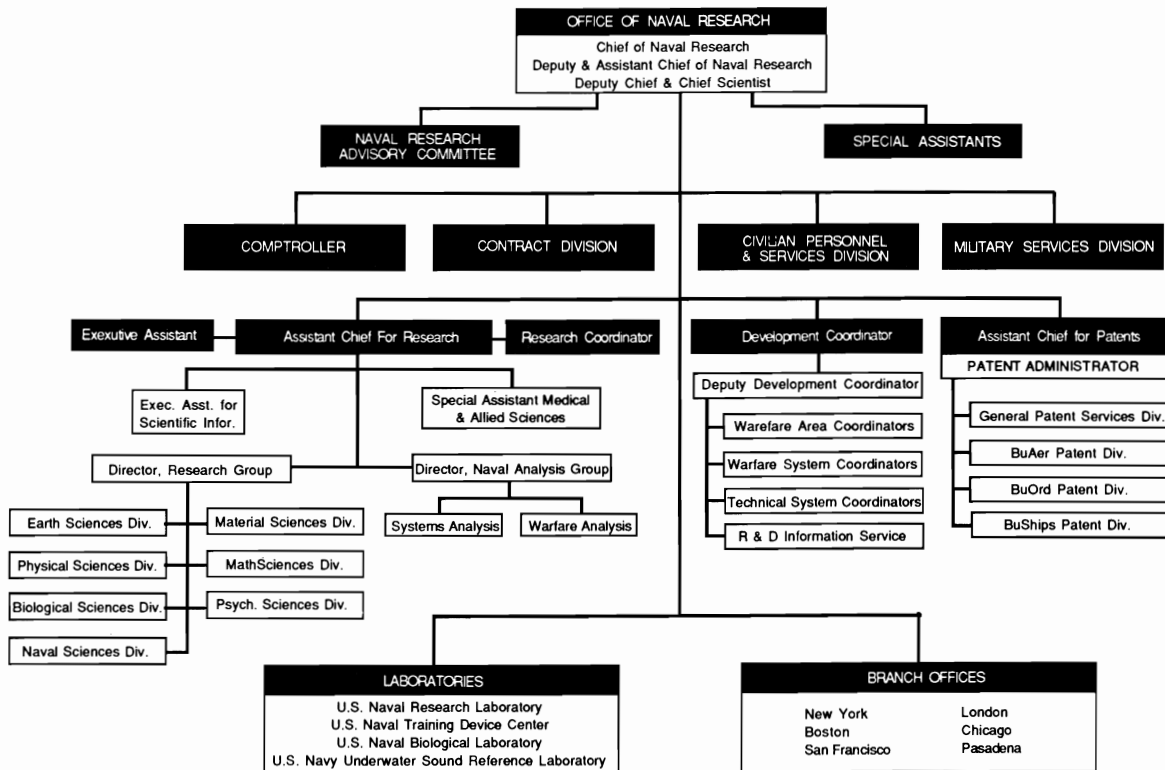

Figure 1. Organizational chart of Office of Naval Research, about 1956-1958.

*Now at Naval Ocean Research and Development Activity, Code 113, NSTL, MS 39529

This presentation is about the Office of Naval Research: its organization, programs and efforts. Since ONR parallels so much of the history of MPL, I think it's worthwhile to give some of the younger members of the audience a bit of history and inform them as to how ONR has changed over the years. First of all I will give a caveat: what I have to say here is unofficial; it does not represent official views of ONR or official views of the Navy. These are my observations and opinions formed while having served in an ONR program office for four and one-half years. I hope these observations will be enlightening.

First of all, let us examine the early ONR organization. I want to tell you about major components of ONR in the early days and compare these with some of the current components. Figure 1 is the organization *circa* 1956-1958, an organization headed by a Chief of Naval Research, a Rear Admiral. I want to concentrate on three groups. The first is a research group under an Assistant Chief of Naval Research. This is the group that funded university research, the non-profit laboratories, and commercial laboratories. The second group is the in-house Navy laboratories, of which there were four. One of those was the Naval Research Laboratory at Washington, which was the dominant laboratory. Scattered through this organizational chart are other groups such as Naval Analysis, Warfare Areas, Technical Developments: groups that attempted to capitalize on the basic understanding that resulted from the basic research programs and to exploit this understanding into technology development areas, new systems, new instruments, and new technologies.

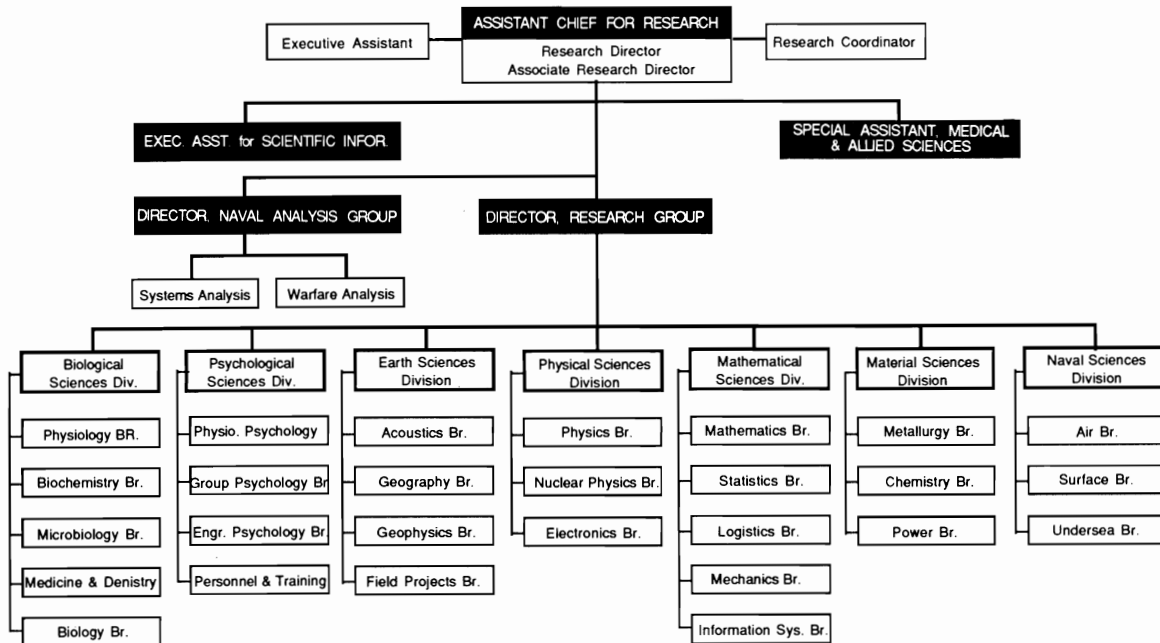

Figure 2. Divisions and scientific/technical program areas in the Research Group, about 1956-1958.

As seen in Figure 2, this Research Group under the Assistant Chief of Naval Research had seven divisions: biological sciences, psychological, earth sciences, physical sciences, mathematics, materials, and Naval sciences. There were some 27 scientific disciplines grouped under these areas. As seen in Figure 3, the organization of these groups has not changed a great amount. They have been reordered and grouped; some more management levels have been added, but in general there is a similar grouping of such scientific programs within the current Office of Naval Research.

Figure 3 shows the current ONR organization. Two things to notice: there is still a Chief of Naval Research, but the office and title have been expanded. The office is now known as the Office of the Chief of Naval Research, largely because there are two parallel organizations under this office. One is the organization that we continue to think of as the Office of Naval Research, similar to what it was in the 1956 era. There also is an Office of Naval Technology. This is the group that supports work beyond basic research, the more applied programs, the exploratory development programs, advanced development programs, programs attempting to capitalize on the basic understanding and knowledge that comes from the ONR basic research programs. In an attempt to promote transitions of knowledge and technologies, they have tried to bring these groups into closer alignment and put them under the same parent organization.

organization that provides most of the research funds for individual investigators at MPL and Scripps. We have two other parallel directorates, Applied Research and Technology and Ocean Sciences and Technology. This last group provides some long-term management that has both basic research programs, exploratory and advanced development funds. Again the purpose is to bring a closer coordination between the research community and some of the applications communities, particularly with respect to the Navy.

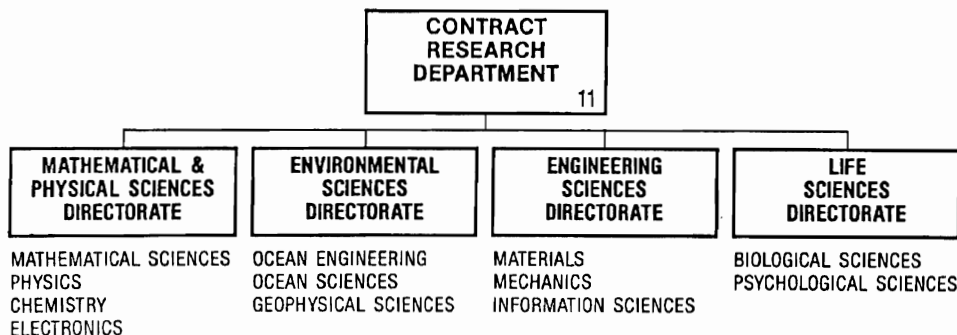

Figure 5. Contract Research Department of the Office of Naval Research, 1986.

Within that Contract Research Department, there are four directorates (Figure 5). There are now twelve divisions whereas there were seven in the 1956-58 era. Two groups, mathematical sciences and physical sciences, have been grouped into one directorate; others such as biological sciences and psychological sciences have been grouped under a Life Sciences Directorate. There has been strengthening of the Environmental Sciences Directorate; that used to be an earth sciences group, but now includes chemical and biological oceanographic groups all under one Environmental Science Directorate. This is the principal group with which Scripps and MPL interact.

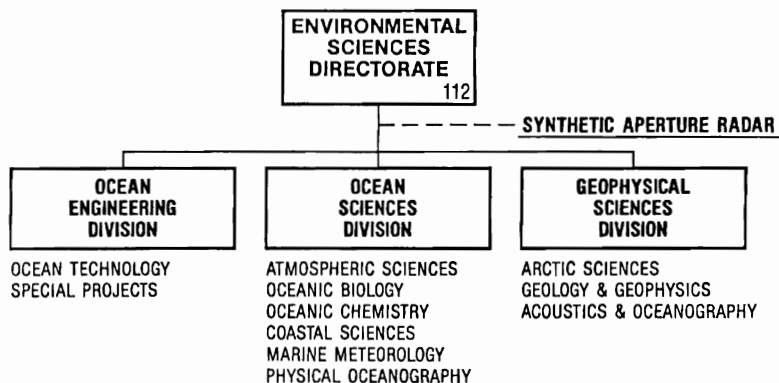

Figure 6. Environmental Sciences Directorate, 1986.

The Environmental Sciences Directorate is again divided into three divisions (Figure 6). The Ocean Engineering Division includes special projects and ocean technology, and more special engineering applications with oceanographic objectives in mind. The Ocean Sciences Division includes meteorology, marine biology, marine chemistry, coastal sciences, and physical oceanography with physical oceanography being the largest of the groups. The Geophysical Sciences Division includes arctic, geology and geophysics, and acoustics and oceanography — a new title for this group which some of you may remember as being called the Ocean Acoustics or Underwater Acoustics groups. A recent reorganization combined those two acoustic groups.

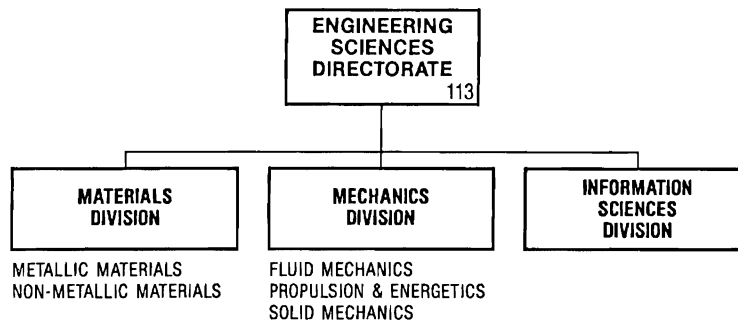

Figure 7. Engineering Sciences Directorate, 1986.

In general you'll see that most of these are fairly broad scientific designators. As you examine other groups, for example, the Engineering Sciences Directorate (Figure 7), you see divisions and titles which convey the connection between the basic research in those groups and the Navy's interest. For example, engineering sciences is a rather broad field. They could deal with a lot of topics in that particular directorate; nevertheless, they focus on metallic and nonmetallic materials, including special alloys, ceramics and composite materials, but more on material properties as opposed to structures themselves. One can understand that it is these properties the Navy is going to try to capitalize on, as far as research vessels, aircraft, and operational vessels. The mechanics division concentrates on fluid mechanics, turbulence problems, propulsions, energetics. In all of these one can see that they have not only good basic research areas but also have direct applications to Navy programs.

That is a brief examination of the organization and what has happened over the last thirty years. We see a couple of things that have happened: ONR has grown in its organizational structure, and it has brought in new groups that are more Navy-oriented to parallel the research communities to strengthen the transition from basic and fundamental research to some of the more applied communities. In general, there are new titles and new names in some of the groups, but there have not been such large organizational changes that one would not recognize the organization now if they had seen it back in 1956.

What has happened to the funding during this same time period? In Figure 8, I have purposely left off absolute dollar figures to show only relative changes over the years. In the early years, the 1956-58 era, roughly 20 percent of the funding went to Navy labs; 80 percent of the funds in basic research went to non-Navy contracts, to the universities and non-profit laboratories. This was a category that was referred to as core funding. It was divided on the basis of scientific disciplines, so much money in physics, so much in mathematics, so much in geology and geophysics, and so on. In fiscal year 1988, the plans are for 22 percent of the money in basic research to go to the Navy labs, not a large change. I might comment here that all of these laboratories have grown to the point that this money which makes up this 22 percent only provides about a quarter of their support and funding; for the other 75 percent, the Navy lab scientists propose through contracts, very much as the universities and the other laboratories do. About 72 percent of this money still remains in the non-Navy contracts, but it has been further subdivided. There are now monies which do not fit exactly into either one of these two categories but may go to both Navy labs and to the non-Navy lab contracts.

The Accelerated Research Initiatives, ARI's, are programs that are focused on particular scientific issues that are proposed and presented by people like myself within the ONR groups. We propose to our management to focus funds and priorities on specific technical areas for nominally five-year periods. The University Research Initiatives are some I am sure that many of the people here at Scripps and MPL are familiar with. These are similar sorts of programs as the ARI's of five years' duration, only these are planned and presented by the university community directly to the ONR management as opposed to going through the ONR structure itself. These URI's are typically million-dollars-a-year efforts, lasting nominally five years. There have been some recent awards: Walter Munk, and a group at MPL have received one of the awards recently under this URI program.

ONR now has a large number of special funding programs; such as Selected Research Opportunities Program, ONR Graduate Fellowship Program, ONR National Research Council Postdoctoral Cooperative Research Associateships, Summer Faculty Research Programs, ONR Research Chairs, University-Navy Laboratory Bridges Program, Historical Black Colleges Council, ONR Young Investigators Program, and the DOD University Instrumentation Program. This last program has completed its five-year life cycle and

ONR FUNDING	
EARLY YEARS (1956-58)	CURRENT YEARS (FY88)
<ul style="list-style-type: none"> • 20% NAVY LABS • 80% NON-NAVY CONTRACTS CORE FUNDING 	<ul style="list-style-type: none"> • 22% NAVY LABS • 72% NON-NAVY CONTRACTS <ul style="list-style-type: none"> 34% CORE 29% ACCELERATED RESEARCH INITIATIVES 6% UNIVERSITY RESEARCH INITIATIVES 3% OTHER PROGRAMS • 6% OTHER

Figure 8. Comparison of ONR funding between early years and current years.

many of you may be familiar with it. It was designed to provide funds for upgrading of instruments and equipment needed by the universities to conduct state-of-the-art research and technology development.

Some of these other programs are to provide fellowships to graduate students, NRC [National Research Council] post-docs — these provide postdocs to recent graduate students to work in Navy laboratories to understand Navy research and Navy interest, faculty programs to bring people out of university faculties into summer positions at Navy laboratories; there are ONR research chairs — one of the oceanography research chairs Walter Munk now holds; there is a University-Navy Lab Bridges Program to provide better communication between the university academic researchers and the Navy lab researchers. There are a large number of programs now which have special focus or objectives beyond a single science focus. Other programs are a miscellany of graduate programs, graduate fellowships, and summer programs.

What we see in effect is: one of the terms which one hears now is matrix management. Where we used to have a very direct flowing of money into scientific disciplines, what we have now is a funding matrix. Along one axis one finds the scientific disciplines: physics, math, geology, and so forth; along the other axis one finds the special program or interest categories with all their special funds. There is something special or unique about those categories; they usually are striving to provide transition of knowledge into applications; or to support university instruments; or to support a specific university community or, in some cases, even a Naval laboratory community. There may be non-scientific motivations originating these programs, but nevertheless the money does flow through this matrix into areas of science. If you add the columns in one way, you get the total dollars in the science categories; adding them the other direction gives dollars that are going into these various special programs. One finds a more complicated arena as far as funding now than what existed thirty years ago. These new special programs have largely taken place within the last five years.

In summary, what has happened to ONR over the last thirty years? There have been reorganizations trying to strengthen ties between the 6.1, our basic research, and 6.2 and 6.3 or more applied and Navy-relevant research and development activities. That has been brought about in the ONR organizational structure, and I believe ONR is seeking new ways to effectively capitalize on this basic research knowledge that is coming out of these communities for Navy applications. I think we see more focused research programs: ones that are focused both in time and on specific technical areas. Much of this movement is the natural consequence of many programs having a finite life such as five years. At the end of that period, the funds are available to generate new programs or invigorate existing ones. There is constant movement of money from special program to special program. In general, there are many more programs outside this scientific core funding. I believe that some of the older researchers may tend to think in terms of these core programs and propose only at a particular scientific core discipline. I think that now the community will have to think in terms of proposals directed at some of these new, special programs. There will be the science involved in that program, but it will also have to meet certain requirements as far as the guidelines of the specific program. Many of these special programs are managed out of other offices at ONR, not at the scientific officer level that I have occupied for about four years, and it is more complex coordinating all of these special categories of funds. I think it will be necessary for the younger researcher to learn as much about these new programs as possible in order to capitalize on them in the future.

DRIFTING ACOUSTIC SENSORS

Victor C. Anderson

*Marine Physical Laboratory
Scripps Institution of Oceanography
San Diego, CA 92152*

At this special symposium it's appropriate to start off by going back in time to identify myself as one of the students in that first course in underwater acoustics that Russ Raitt taught back in 1947. That was my introduction into underwater acoustics, and underwater acoustics has been in my life's blood ever since. I owe a vote of thanks to Russ for that transfusion. A few years later Russ was on my doctoral committee, again influencing my future; it was his work on scattering and reverberation that inspired my thesis topic on the deep scattering layer. One of the things that I recall most clearly from those early days was Russ's very strong emphasis on the importance of minimizing the system noise in making acoustic measurements. That early impression must have been a lasting one because, since then, I've concentrated my acoustics research on the measurement of background noise in the ocean, including the signal processing and instrumentation associated with such measurements.

Now, 40 years later, I'd like to give you a glimpse of one of our current projects in instrumentation for background noise studies in the ocean. The frequency region of interest is the VLF band (1 to 20 Hz), the same region that Raitt found useful in his seismic-refraction studies. The difference here is that, while for him the background noise in the ocean was an interference that limited the reception of the seismic shot signals, that very background is the essence of our studies and any spurious seismic profiling signals interfere with our background noise measurement. This VLF frequency band is set in context by the summary plot from Kibblewhite and Ewans (1985) reproduced in Figure 1. There is a considerable spread in the measurements by various experimenters as can be seen in the composite plot. In addition, there is a disparity among the theoretical predictions by Hughes, Wilson, and Goncharov which are also shown. It is apparent that our understanding of the nature of the background noise in the 1- to 20-Hz region is confused at best.

Measurements in this VLF band are plagued with flow noise over the sensing hydrophones and/or vibration or "strum" of the connecting cables caused by flow past the cable. The technique that Raitt used to reduce this noise was to use drifting sensors, either a neutrally ballasted hydrophone that could be pulled in close to the ship and then released on a slack cable to remain stationary with respect to the water during the interval that the signal from a refraction shot was received, or in later years to use sonobuoys with RF data links to the ship.

The approach we are taking is similar in that we are using drifting sensors to measure the ambient VLF noise field. It differs in that the sensor packages are autonomous "Swallow" float buoys ballasted to float at a depth of several hundred meters, well below the influence of surface waves and surface currents. The buoys have the capability of recording up to 40 hours of digitally sampled data from a three-axis set of accelerometers plus station-keeping pulse-timing data from an associated pinger system. Ten or more of these VLF buoys will be simultaneously deployed as independent freely drifting sensors in a loosely defined array configuration. Each will record the station keeping pulses from the other buoys in a "round robin" sequence, thereby documenting reciprocal travel times between all of the pairs of buoys. Using these reciprocal times the internal clocks of the buoy set can be corrected to a common time base to within a millisecond, and travel-time separation between pairs can also be determined to within a millisecond. From the dynamically varying relative geometry of the array as reconstructed from the pair separations, and the common time base, the data sets can be coherently combined to form directional beams to estimate the directional structure of the background noise field.

The details of the VLF buoys are shown in Figure 2. The electronics is contained within a 43-cm diameter glass sphere. It includes the lead acid battery power supply, a 17-MB cassette tape recorder, the control computer and associated CMOS buffer memory, a three-axis accelerometer set, a magnetic compass, programmable gain-signal conditioning amplifiers and A/D converter, and acoustic-pinger and

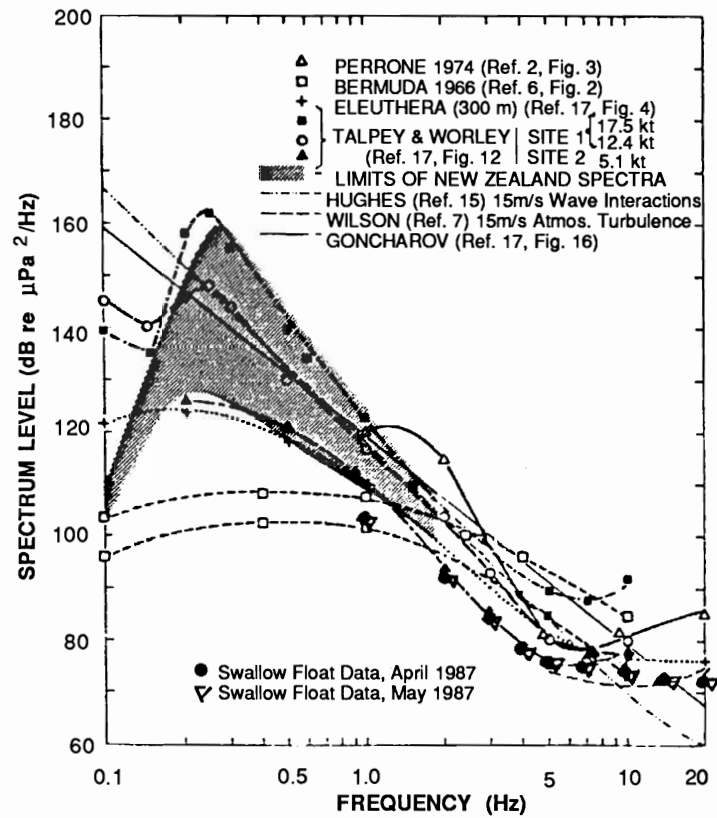

Figure 1. Comparison of various ambient noise data sets.

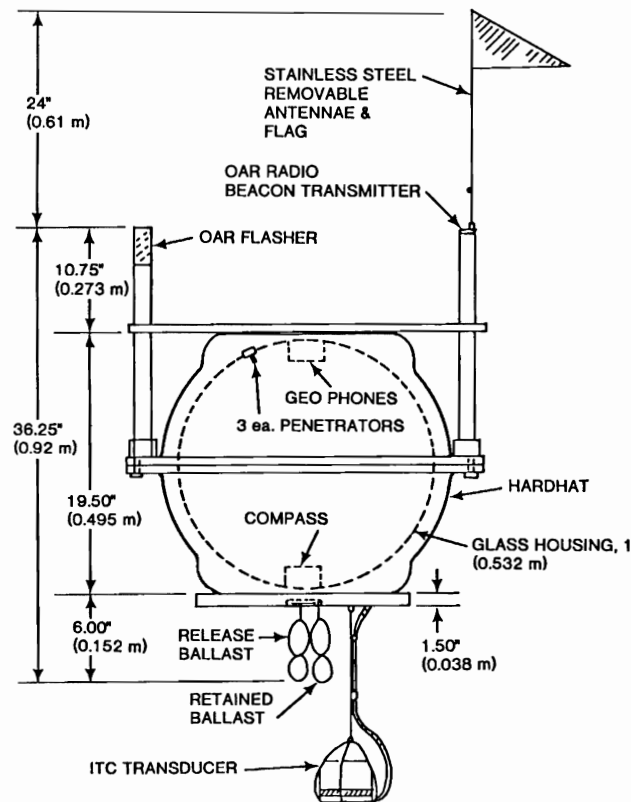

Figure 2. Schematic of very low frequency buoy.

command-receiver electronics. External to the glass pressure case is a self-contained flasher for sighting during surface recovery and a radio beacon for the same purpose. Trim ballast and releasable ballast for recovery are suspended below the buoy, as is the acoustic transducer associated with the pinger and command-receiver functions.

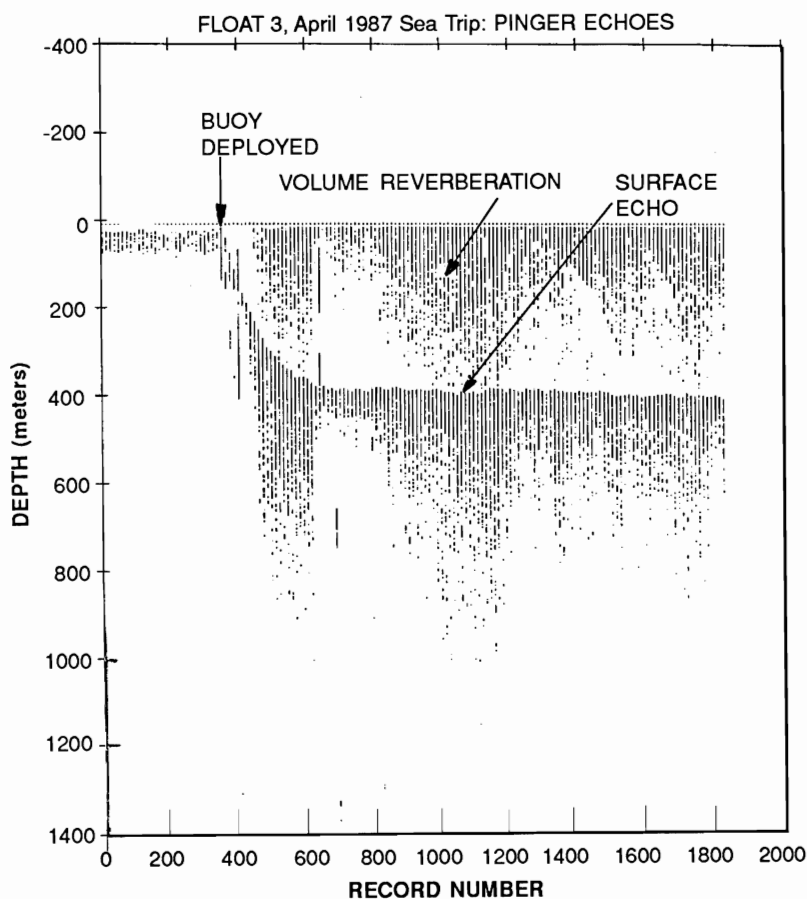

Figure 3. Plot of time delay of returns from Swallow float.

The buoys weigh approximately 50 kg and are easily launched and recovered over the side of the ship with a light davit. It takes about four hours for a buoy to sink to a 400-meter ballasted depth and stabilize. The surface-to-depth transition is illustrated in Figure 3, which is a plot of the time delay of returns from float number 3 as it listens to its own ping transmission. Each record is 45 seconds long. For the first 350 records the buoy was on deck. After the buoy has descended into the region of the deep scattering layer, nearby volume reverberation precedes the surface echo and its trailing surface reverberation. In the later part of the record, internal wave motion with excursions as great as 10 m can be observed.

Several sea tests have been carried out with the buoys. These have been engineering tests of the buoy performance and deployment methods. Characteristic spectra from one of the data records are shown in Figure 4. One feature that appears in the spectra is that above 5 Hz the dominant energy comes from the horizontal. The vertical, z-axis accelerometer shows 10-dB lower spectral levels except for a few isolated lines which probably originate from the nearby ships engaged in the experiment. The spectral levels have been converted to equivalent acoustic-pressure spectrum level based on the assumption that the field is composed of a large number of statistically independent plane waves. Using the same premise, all three records are combined in a power sum to estimate the equivalent omnidirectional pressure-spectrum level. For comparison, representative spectrum levels from sea deployments in April and May of 1987 are superimposed on the summary data plot of Figure 1. It appears that we have indeed succeeded in developing an instrument which can measure the true ambient noise in this VLF-frequency regime; these spectral levels lie on the minimum of the data sets presented.

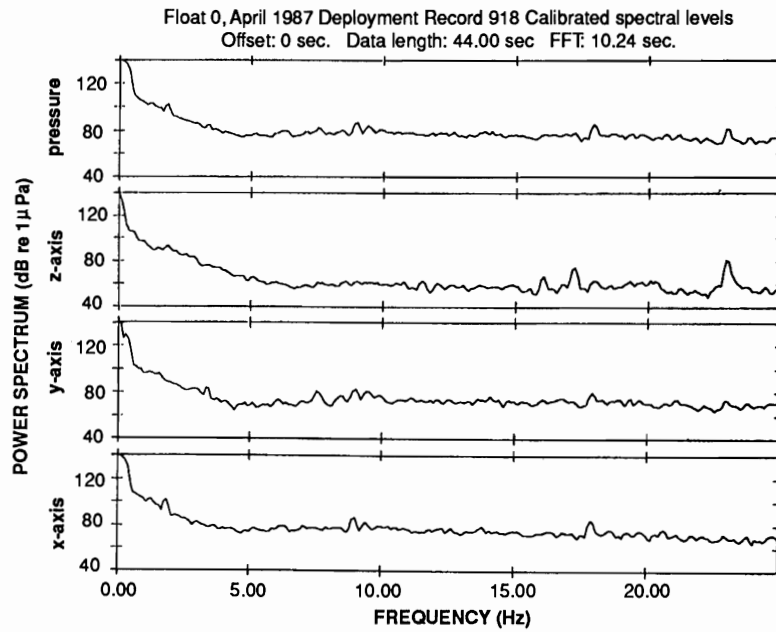

Figure 4. Characteristic spectra from one of data records.

To date we have not carried out the coherent beam-forming analysis of data sets. However, the results of our tests so far indicate that the data we are recording represent true VLF ambient noise, and, further, that the element location system will provide the required precision for beam-forming analysis. The directional spectral analysis is next on the list.

Reference

Kibblewhite, A. C. and K. C. Ewans. 1985. Ambient noise in the ocean. *J. Acoust. Soc. Am.* 78:981-994.

MODELING MULTI-BOUNCE PHASES IN MARINE SEDIMENTS

Donald V. Helmberger

*Seismological Laboratory
California Institute of Technology
Pasadena, CA 91125*

Comments

I'm going to talk a little about some of the things I learned from Russ many years ago. One day I asked Russ what I should do with some of the records that we took in the Bering Sea — this was about 25 years ago. These were very classy seismograms, high quality, even by today's standards, I would say. I asked him, "These are nice records, and they look as if we understand them, but what are we going to do with them? What should I do about it?" I don't recall exactly, but I think he got up and went for a walk. But eventually he said, "Why don't you make a numerical model of these things?" Of course nobody at that time ever made a numerical model of anything. So I said, "Good, great — how do I do it?"

It turns out that Russ, with his physics background, provided essentially all the tools to make numerical seismograms. He knew precisely what the instrument recorded. If there were a delta function, pressure in the water or some kind of a time function in the water, he knew exactly what that instrument would record. He also knew exactly what the explosions did. He didn't know where his instruments were all the time. I think that the Marine Physical Laboratory hydrophones don't always go where they think they do; they kind of wander up and down in the ocean.

Essentially, Russ was very pioneering in starting the idea of modeling seismograms. Since then we've probably produced half a million or more seismograms of modeling. I would have to say that I owe all my background in this to some rather strange conversations with Russ that were very productive.

Introduction

In this brief review I shall discuss some of the properties of seismic waves partially trapped between the surface of the ocean and the sub-bottom structure. At the higher frequencies of 200 Hz it appears that only the top few meters of the bottom structure are involved. However, there appears to be considerable penetration into the sub-bottom at the lower frequencies of 5 to 20 Hz commonly used in refraction studies. A sample of some observations of this type is displayed in the upper panel of Figure 1. These responses are the output of three hydrophones at slightly different depths and ranges. The three data channels are recorded after being low-passed (LP) and high-passed (HP) as indicated. Graphical explanations of the various energy paths and labels, P_B , P_{SB} , $P_B P_{SB}$, and $P_{SB} P_{SB}$ are given in the lower panels. The pulse P_B is reflected by the density contrast at the water-mud interface and appears to be reasonably independent of ray parameter as displayed in Figure 2. This record section was constructed from the low-passed trace and aligned with respect to the high-frequency bottom reflection (s_1) as labelled in Figure 1. (s_2) indicates the first multiple ocean-bottom reflection. At about 6 km a sub-bottom response, P_{SB} , becomes apparent and is caused by the critical angle phenomenon, essentially a triplication. A similar enhancement occurs for the multi-bounce phases $P_B P_{SB}$ and $P_{SB} P_{SB}$ as they approach critical angles at the appropriate larger ranges; for instance P_{SB} and $P_{SB} P_{SB}$ have maximum amplitudes near 8 and 16 km, etc. The ratios of the various pulses can be used to invert for the velocity, density, and attenuation properties of a parameterized bottom structure (Figure 3). These synthetics were generated from a flat homogeneous layered bottom with the overall velocity-depth function displayed in Figure 1 (Helmberger *et al.*, 1979). The next set of multiples peaks near 24 km, etc., and becomes quite predictable out to many bounces (Barker and Helmberger,

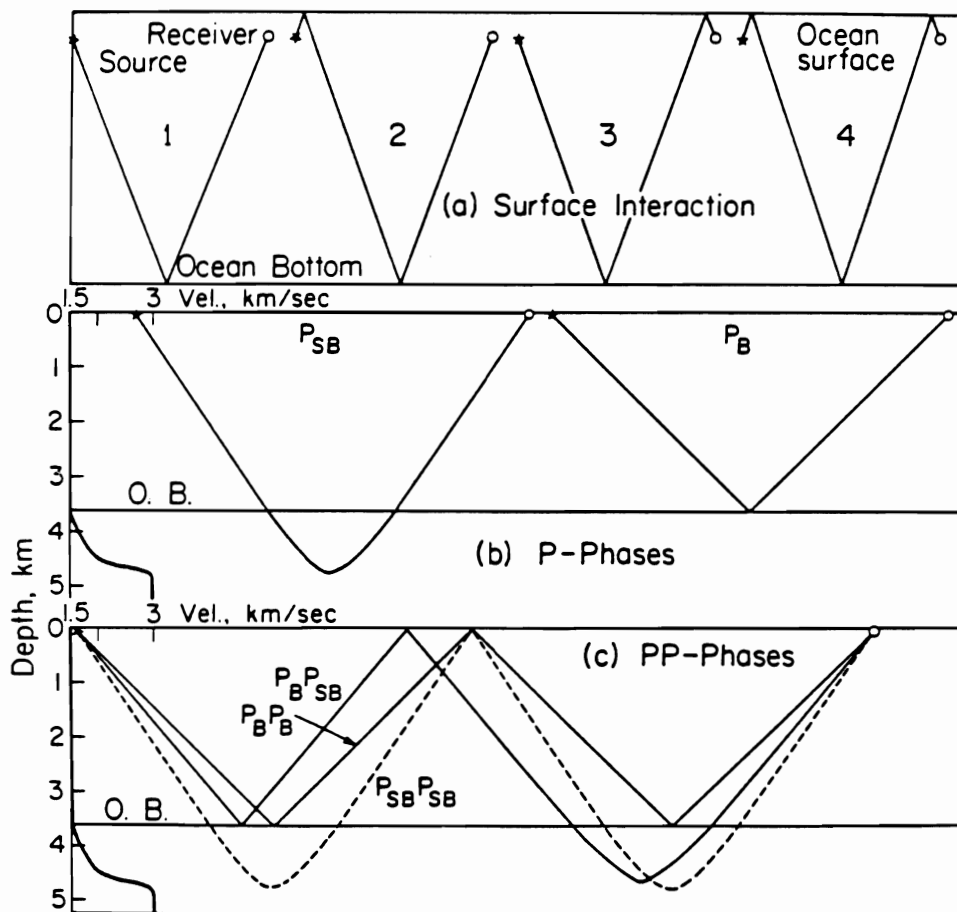
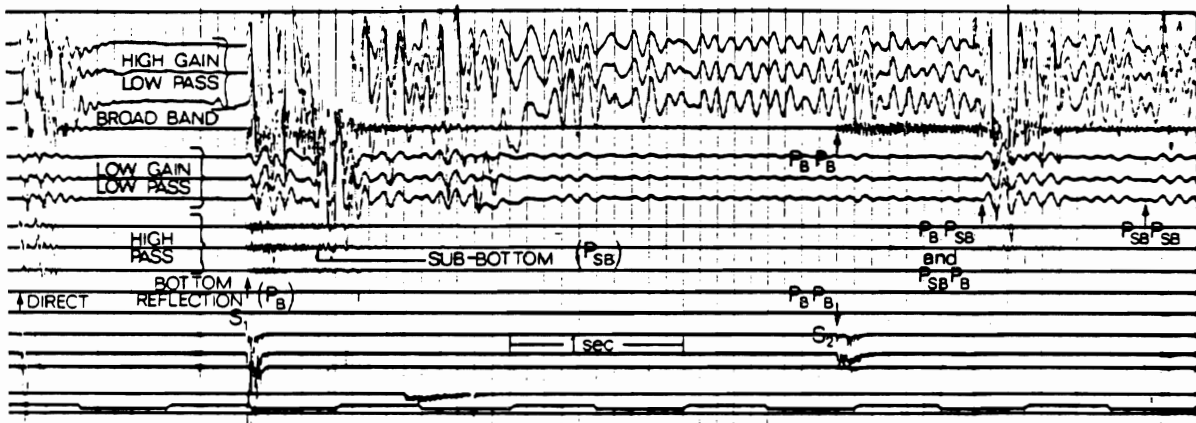

Figure 1. An example of a refraction record taken in the Aleutian Basin at a range of 10 km is displayed in the upper panel. The traces with the labels S_1 and S_2 are rectified output used in the accurate identification of water-bound arrivals. The other labels are associated with energy paths indicated in the lower panels.

1986). Predicting the behavior at higher frequencies becomes more difficult as these sub-bottom multiples show strong changes in frequency, as indicated in Figure 4.

The amplitudes appear to behave nearly elastically below 10 Hz, but the pulses penetrating below a few hundred meters of the bottom are clearly depleted in higher frequencies. These properties can be explained to some degree by frequency-dependent Q model (Barker and Helmberger, 1986), but an

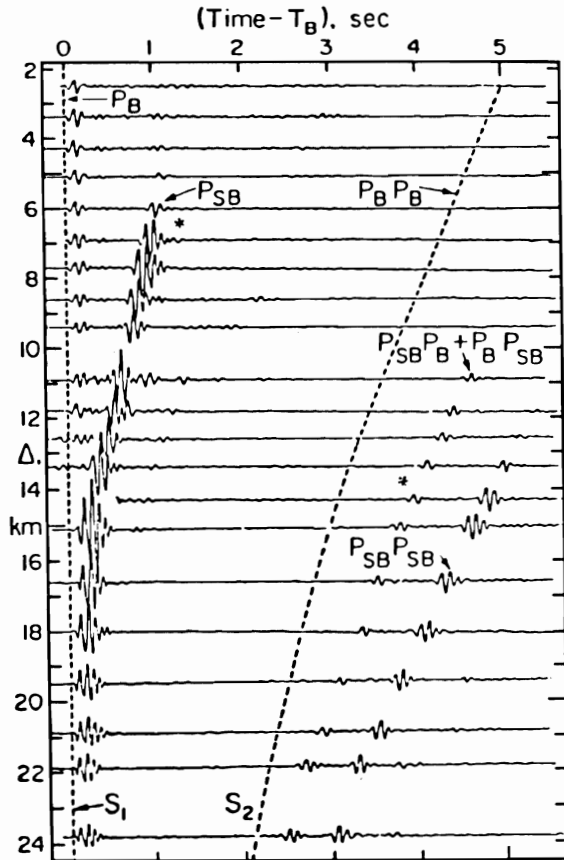

Figure 2. Record section constructed from a profile of data (Leapfrog 13; Shor, 1964), where the reducing time is relative to the bottom-reflection time.

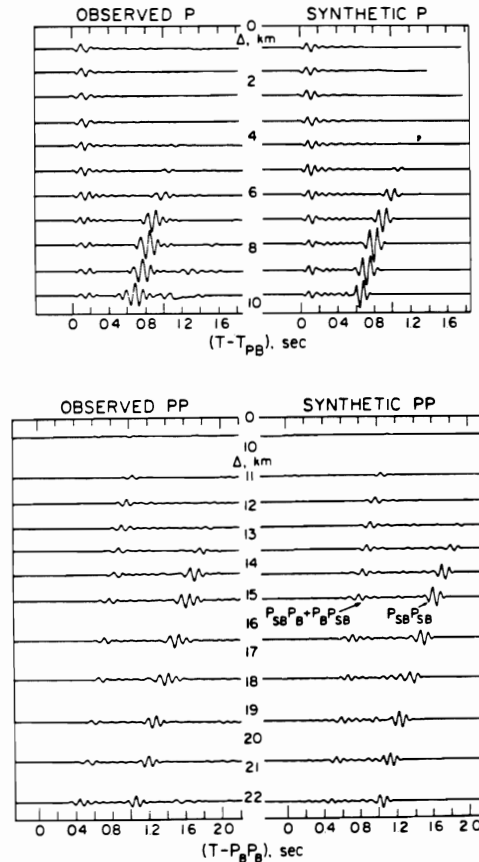

Figure 3. Comparison of observations and synthetics for a flat-layered model where the amplitude-scale factors are the same for both plots (after Helmberger *et al.*, 1979).

explanation involving the scattering properties of the irregular interbedded bottom sediments is probably more realistic. Thus we encounter a breakdown in the ability to predict detailed high-frequency behavior with idealized analytical codes and the simple model parameterization required for their application.

The above example shows particularly the usefulness of interfacing analytical and numerical codes. That is, we would like to add a complex three-dimensional zone (referred to as the rubble zone) at the ocean floor which would be treated numerically with very small grid spacing and coupled to smooth models above and below.

Numerical Methods for Wave Simulation

The most accurate method of modeling waves in complex media is with direct finite-difference (FD) or finite-element (FE) solutions of the wave equation. In practice, limited computer resources have restricted the use of these techniques to relatively small two-dimensional problems. However, with the recent development of highly parallel computers (hypercubes, for example), the FD methods are becoming increasingly attractive for general purpose simulations.

Some results from a numerical calculation involving shallow-water and long-period motions but still displaying some of the elastic effects associated with a hard bottom are displayed in Figures 5, 6, and 7. In Figure 5 the behavior of ocean waves near a ridge is illustrated. The upper panel shows the geometry of the problem. The lower panels show the divergence (P -waves) and curl (S -waves) components of the solution at a particular time point. The presence of s -waves beneath the sea floor shows that the ocean acoustic waves are coupling elastically into the solid medium. The responses with acoustic (Figure 6) and

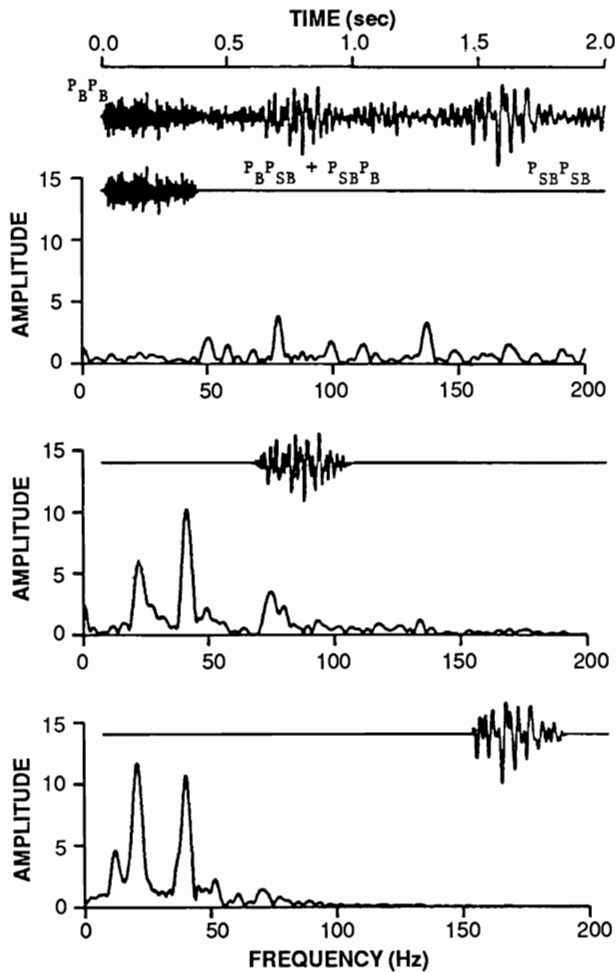

Figure 4. An example of Fourier spectral estimates for the PP phases. Shown at the top is the broad-based signal for shot 766 (14.3 km). In the lower panels are the windowed seismograms and amplitude spectra for the $P_B P_B$, $(P_B P_{SB} + P_{SB} P_B)$, and $P_{SB} P_{SB}$ phases.

elastic (Figure 7) simulations were generated both with and without the ridge. The results show that the presence of the ridge adds significantly to the complexity of the seismograms. Also, this example shows the importance of considering a fully elastic sea floor in ocean acoustics when the bottom is hard. We note that the snapshots of the field displayed in Figure 5 further emphasize the usefulness of a code-mix since the smooth wave fronts can be handled so much more easily analytically; this is especially true in three dimensions.

Interfacing Analytic and Numerical Methods

Numerical schemes that handle material irregularities are very powerful and can be applied to a large variety of situations as discussed in the previous section. However, the expense of calculating the response at large distances compared to wave length is prohibitive. Geometric ray methods are useful for predicting scattering of signals which have wave lengths that are short compared with the size of the heterogeneity. Unfortunately, these ray-based methods do not predict frequency-dependent amplitudes of scattered pulses in many situations.

For cases involving sharper features the Kirchhoff methods can be employed. This approach is generally valid at longer wave lengths and has found wide applications in electromagnetics and acoustics. The Kirchhoff methods have been shown to yield geometric optics at high frequencies. I shall briefly discuss some useful generalizations to these techniques by Scott and HelMBERGER (1983; 1985) and show

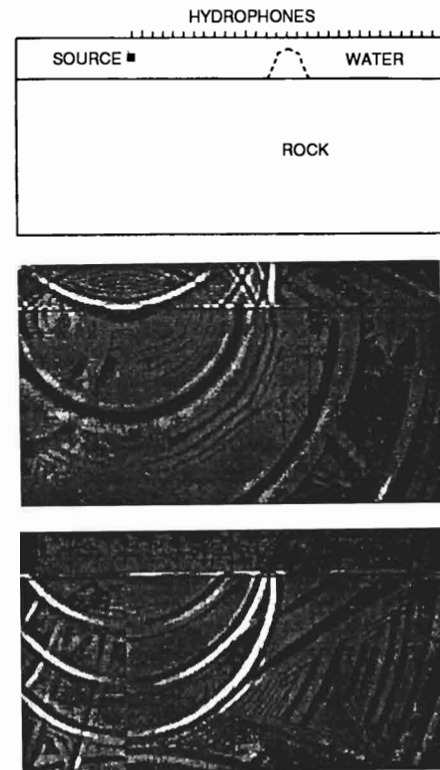

Figure 5. An example of finite-difference modelling in an ocean environment. The top panel shows the geometry with a water layer over an elastic half-space. The model contains a ridge. The square is the location of the explosive source, and the ticks are the receivers. The middle panel shows a time slice of the divergence field (P wave), and the lower panel shows the corresponding curl field (S waves).

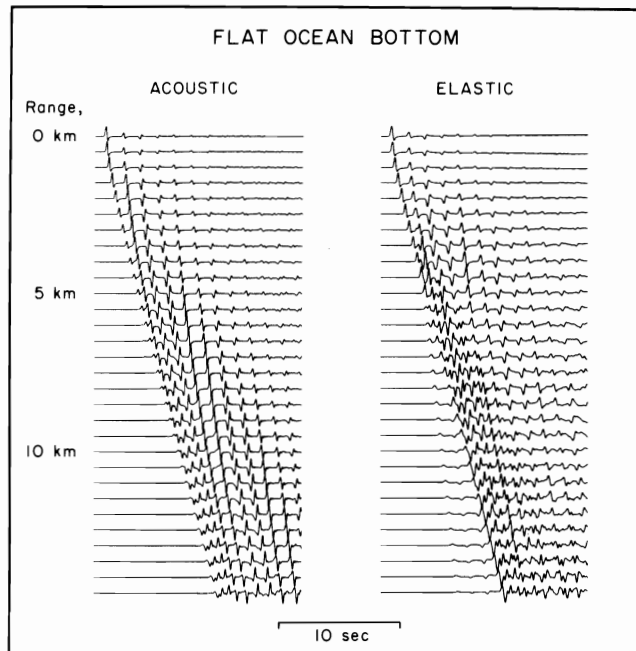

Figure 6. The results for acoustic and elastic simulations in the model shown in Figure 5 without the ridge. The results show the importance of including elastic coupling in the sea floor.

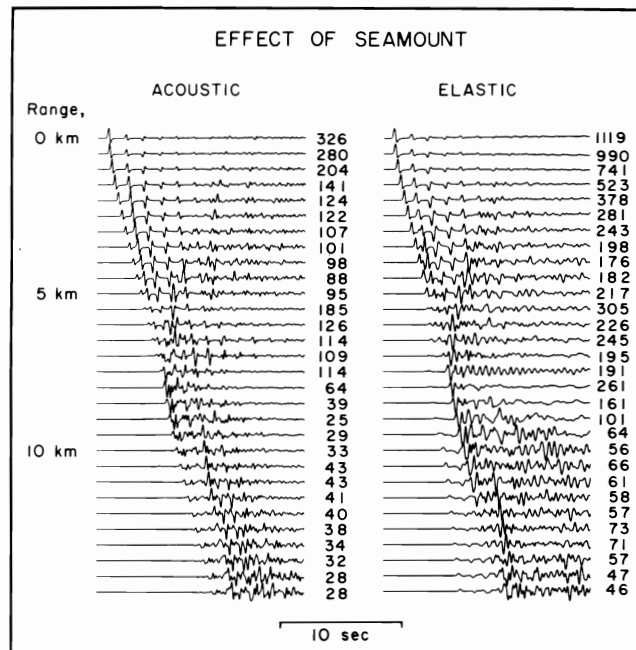

Figure 7. The results for acoustic and elastic simulations in the model shown in Figure 5 with the ridge. The ridge substantially increases the complexity of the seismograms, especially with the fully elastic simulation.

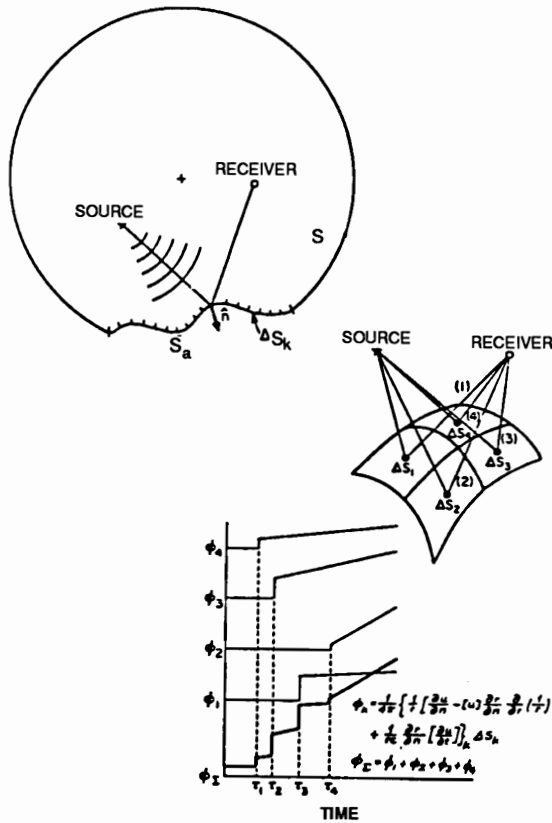

Figure 8. The closed surface of integration which is composed of S_α , the surface over which one carries out the numerical integration, and S_β , that which does not contribute to the signal in the time window of interest, is displayed at the top. The lower portion shows the summation of the response from each element to obtain the total field.

how to exploit the Kirchhoff method with respect to interfacing numerical and analytical codes.

Following the Kirchhoff technique the transmission and reflection of waves from a surface of discontinuity is described by an integral formulation of wave motions on the surface (Figure 8).

$$\bar{u}(\vec{r}, t) = \int_{S_\alpha} \left\{ \frac{1}{r} \left[\frac{\partial u}{\partial n} \right] - \left[u \right] \frac{\partial r}{\partial n} \frac{\partial}{\partial r} \left[\frac{1}{r} \right] + \frac{1}{rc} \frac{\partial r}{\partial n} \left[\frac{\partial u}{\partial t} \right] \right\} ds.$$

where r is the distance from the receivers to the surface, $\partial u / \partial n = \nabla u \cdot \hat{n}$ where \hat{n} is the outward pointing normal and c is the velocity. The squared brackets denote retarded values, namely

$$t - \frac{|r|}{c}.$$

This integral is formally exact and is a mathematical representation of Huygen's principle; that is, a disturbance at a receiver point is a superposition of secondary waves proceeding from a surface existing between that point and the source. Diffraction phenomena arise from the mutual interference of these secondary disturbances. However, one needs the value of the potential or its derivatives on the surface to calculate $\bar{u}(\vec{r}, t)$. This equation may be solved for $\bar{u}(\vec{r}, t)$ or $\nabla u \cdot \hat{n}$ on the surface subject to constraints imposed by boundary conditions. This approach is taken by Mitzner (1967) but is costly for high-frequency scattering.

Alternatively, one may estimate the values on the surface by invoking an approximation. Namely, assume that on the surface

$$u(t) = f \left[t - \frac{r_0}{c} \right] / r_0$$

$$\frac{\partial u}{\partial n} = \frac{\partial r_0}{\partial n} \frac{\partial u}{\partial r_0} = -f \left[t - \frac{r_0}{c} \right] - \frac{1}{c} \frac{f' \left[t - \frac{r_0}{c} \right]}{r_0}$$

Here r_0 is the distance from the source to the surface, $f(t)$ is the time function of the source and f' denotes time differentiation. This approximation is variously called the Kirchhoff, physical optics, or the tangent-plane hypothesis and is widely used by workers in electromagnetic scattering investigations (Davies, 1954). In making these estimates, it is assumed that every point on the surface reflects the incident pulse as though there were an infinite plane tangent to the surface at that point. Hence the reflection coefficients are those appropriate to a plane. This approximation is valid when the local radii of curvature greatly exceed the incident wave length. It is always true if the wave lengths are short enough; thus the Kirchhoff approximation is a high-frequency approximation. These assumptions neglect effects of multiple scattering and gradual shadowing. However, because the integral representation is formally exact, one may specify any realistic potential on the surface. Instead of invoking geometric-ray and plane-wave approximations, one may use the known analytical function describing refractions along a planar surface to calculate responses at distances past critical angle. The Kirchhoff calculations may then simulate the gradually decaying field as one moves into the shadow.

Evaluation of the integral becomes relatively simple with the Kirchhoff approximation and can be calculated by adding up elements of the surface numerically (Figure 8). For the time function $f(t)$ we have chosen a ramp function. This choice circumvents the problems of numerically simulating a delta function. Thus, the sum of the ϕ 's approaches a ramp.

We can gain some insight into the usefulness of this formalism by computing the responses for a few simple structures. First, we examine the nature of a reflection from a smooth idealized mountain where the topography is shown in the upper panel of Figure 9. The reflecting surface is specified on 150 x 150 km grid with each element of the grid being 0.5 km long. Since the angle between the normal of the surface and the incident source ray is calculated by the code, it is simple to plot the path of the reflected rays. These rays are traced for two depths below the baseline of the free surface, namely 50 km in the upper panel and 1000 km in the middle. The Kirchhoff-reflected responses appropriate for the lower horizon are displayed in the bottom panel. As the horizontal distance of the receiver changes, we see systematic wave-form variations which can be interpreted in terms of rays interacting with caustics. In the ranges of 0, 50, 100 and 150 km the synthetics have complicated pulse shapes caused by the interference of three families of rays. The first arrival is a simple pulse with a π phase-shift caused by the reflection off the free surface. The second pulse is a reflected ray with a path which is tangent to the caustic formed by the shape of the mountain and has phase $(\pi + \pi/2)$. The third pulse reflects off the mountain and travels through the geometric focus and has phase $(\pi + \pi)$. The amplitude of these four distances is controlled by the interference pattern and is highly source dependent. At distances beyond 150 km, the latter two rays arrive closely in time and form the second arrival. Note that a simple ray interpretation of pulses on records past 400 km is no longer valid since such a theory predicts no second arrival. The first arrival is just the reflection off the free surface to the right of the mountain and approaches the flat-surface reflection below about 600 km (Scott and Helmberger, 1983).

This example illustrates two points: the importance of knowing where the caustics are with respect to any simulated receiver position, and the effectiveness of the Kirchhoff method in computing diffraction effects. The latter results are particularly gratifying because one does not expect infinite amplitudes or abrupt shadow zones predicted by optics in real physical systems.

Another interesting application of the Kirchhoff method to transmitted signals is displayed in Figure 10 where we examine the effects of allowing various distortions of the crust-mantle boundary. In this problem the source and receiver are centered directly above and below the structure although other geometrics are considered in Scott and Helmberger (1985). Following the Kirchhoff approach, one can deduce the amplitude by examining the behavior of the rate of surface area contributing to the response per unit of time, or

$$A(t) \propto dS(t) / dt .$$

For example, the initial 0.375 sec of the synthetic from a flat interface results from a rapid increase in the cumulative area of the surface which is illuminated between $t = 0.125$ and 0.25 sec. After $t = 0.25$ sec, the area of the surface is illuminated at a constant rate. The resultant synthetic can be viewed as a convolution of the source time function with a step function which is, of course, the optical result. The travel-time contours in Figure 10b for the upwarp differ considerably from those of the flat interface in Figure 10a. Far less of the upwarped surface is illuminated within the $\delta t = 0.25$ sec time interval associated with the geometric arrival and thus the weak beginning. The upwarp topography causes subtle changes of the width between travel-time contours. There are two locations where this change occurs: at the top of the upwarp, and at the bottom. The first pulse in this synthetic originates from the elements in the first location while the second pulse originates from the second location. Because the ring of elements associated with the second pulse is larger, we obtain a bigger arrival. In short, the relative strengths of arrivals crossing or

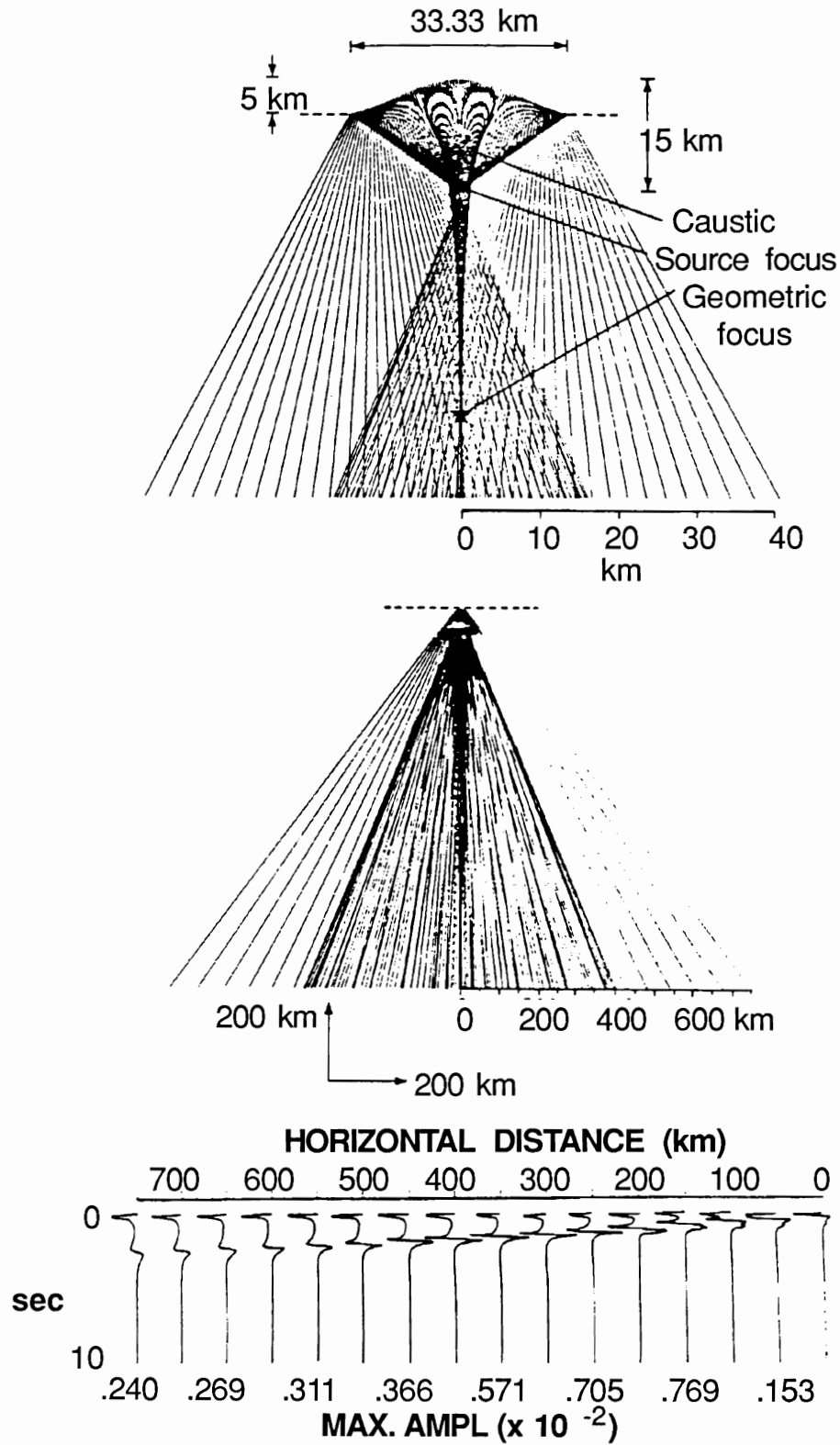

Figure 9. The top ray plot shows the reflection off a smooth tapered cosine mountain (3D). The middle plot is the same picture but on a smaller scale and the bottom displays a set of synthetics showing the behavior at various positions relative to the caustics. After Scott and Helmberger (1983).

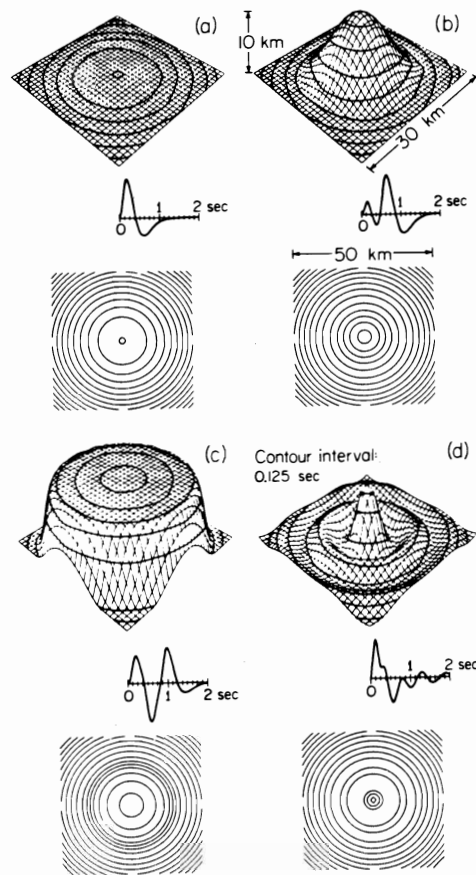

Figure 10. Travel-time contours for a source 35 km directly above the structure and receivers 20,000 km directly below the source. The four structures are: a) a plane; b) an upwarp; c) a plug; and d) a sine function. The contours are projected onto the topographies and flat grids. The synthetics which correspond to each travel-time projection are between the two projections. The contour interval is 0.125 sec as are the tick marks of the synthetics. The geometric arrival time is the center of the contours. After Scott and Helmberger (1985).

reflecting from three-dimensional structures depend strongly on variations in the third dimension.

These two three-dimension examples serve to motivate further development of this technique as a convenient method of interfacing codes. For instance, we could easily compute the response (illuminate the elements) in the upper surfaces displayed in Figure 10 by numerical means and propagate the signals to somewhere else by analytical methods. Furthermore, if we place the Kirchhoff surface in a zone of homogeneous material, we obtain essentially an exact integral representation.

I shall briefly describe this type of interfacing but reduced to two dimensions. The two-dimensional Kirchhoff representation is given in Figure 11 where K_0 is the modified Bessel function. The summation procedure is similar to that discussed earlier except that we need only sum over a line of elements since we are assuming symmetry.

One of the most controlled experiments, consistent with the motivation above, is that of explosions fired at Yucca Flats at the Nevada Test Site. The local structure of Yucca Valley is a basin containing alluvium and volcanic tuffs. Some cross-sections of the structure are displayed in Figure 12. Some example data and synthetics are displayed for various source receiver combinations. In general, sources fired in the basins produce strong Rayleigh waves such as situations involving station 789. On the other hand, stations located on harder rock see much reduced surface waves, as in situation 791. Stead and Helmberger (1987) have modeled their features and show that the scattered surface waves leave the local field and reappear as teleseismic body waves, as displayed in Figure 13.

In demonstration of how two-dimensional Kirchhoff constructs the teleseismic wave form, Figure 13 shows a series of synthetics for two different take-off angles (15 and 20°) for four source positions. Also included is the flat-layered case with amplitude (0.84). As the sources move nearer to the edge of the basin, we see the development of strong later arrivals. Examples of events with appropriate geometry are given in the lower panel of Figure 13.

From the Laplace transform of the 2-d wave equation in cylindrical coordinates, Green's transformation gives the result

$$\bar{u}(P) = \frac{-1}{2\pi} \int_{\Gamma} \left[\bar{u} \frac{\partial}{\partial n} K_0 \left(\frac{sr}{\alpha} \right) - K_0 \left(\frac{sr}{\alpha} \right) \frac{\partial \bar{u}}{\partial n} \right] dl.$$

Using the approximate form of K_0 ,

$$\bar{u}(P) = \frac{\sqrt{\alpha}}{2\sqrt{2\pi}} \int_{\Gamma} \frac{1}{\sqrt{sr}} e^{-\frac{sr}{\alpha}} \left[\bar{u} \left(\frac{s}{\alpha} + \frac{1}{2r} \right) \frac{\partial r}{\partial n} + \frac{\partial \bar{u}}{\partial n} \right] dl.$$

Inverting to the time domain,

$$u(P) = \frac{\sqrt{\alpha}}{2\sqrt{2\pi}} \int_{\Gamma} \frac{1}{\sqrt{r}} \left[\frac{1}{\sqrt{t}} * \left(\frac{\partial u}{\partial n}(r, \tau) + \frac{1}{2r} \frac{\partial r}{\partial n} u(r, \tau) + \frac{1}{\alpha} \frac{\partial r}{\partial n} \frac{\partial u}{\partial t}(r, \tau) \right) \right] dl$$

where $\tau = \text{retarded time} = t - \frac{r}{\alpha}$.

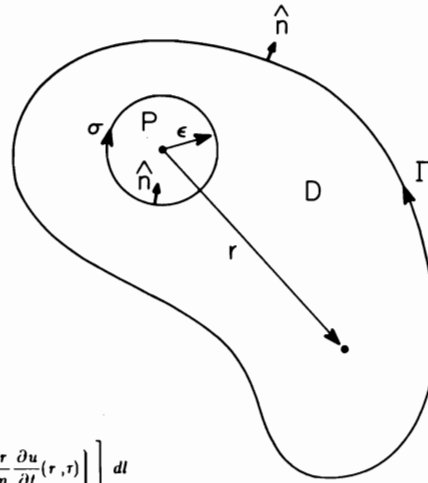

Figure 11. Diagram indicating the enclosed two-dimensional surface and corresponding integral representation.

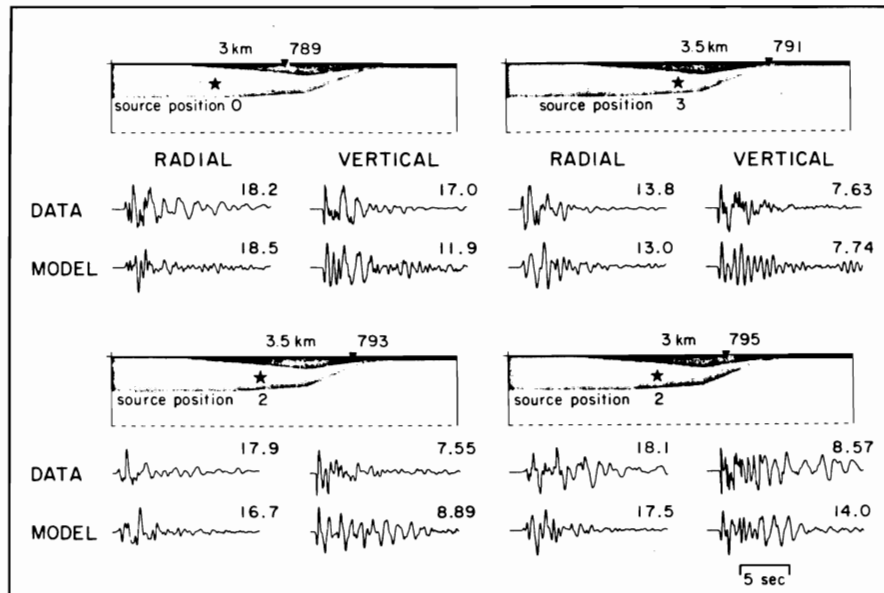

Figure 12. Direct comparison of strong ground motion. This figure shows some direct observed to synthetic comparisons of strong ground motions for the FLASK event. This demonstrates that, despite the simplicity of the model used, the resulting strong motions are an accurate representation of those observed.

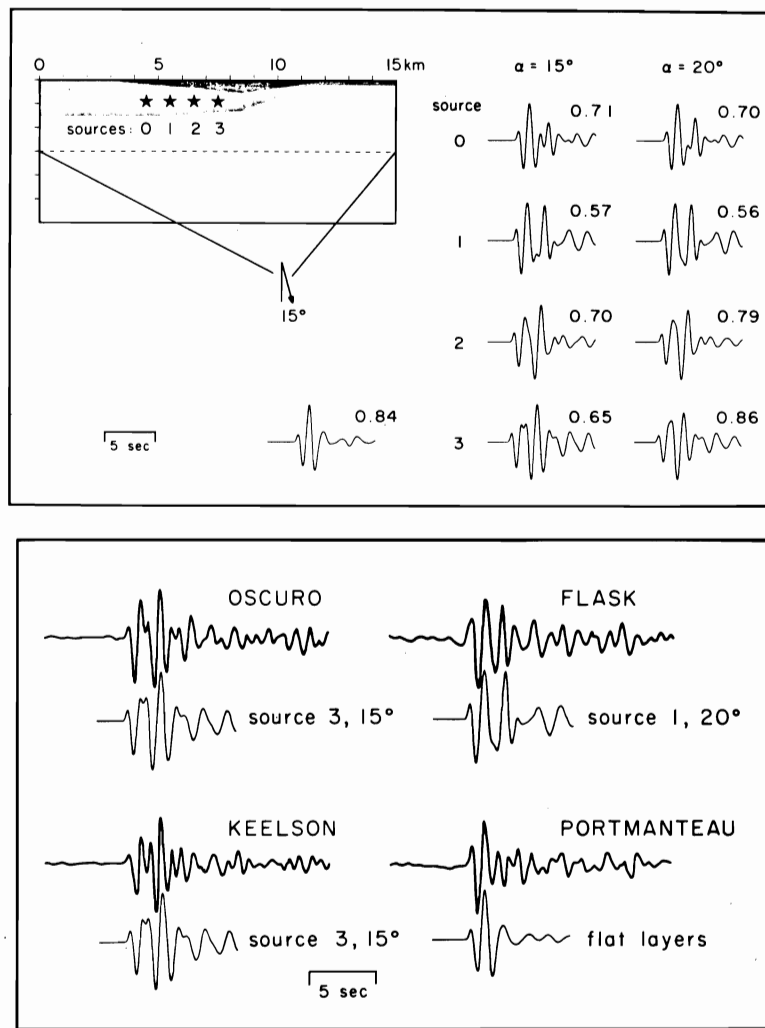

Figure 13. Direct comparison of teleseismic records. These comparisons demonstrate the accuracy of the new method. Although the P waves have passed through the mantle and receiver structure, the majority of the energy in the observed records is explained by the near source structure at Yucca Flat. The repeatability of the method is demonstrated by KEELSON and OSCURO. These events are located close together and are modeled well by the same synthetic record.

Summary

Long-period multiple reflections from the ocean bottom in the Bering Sea can be accurately modeled with synthetic seismograms. A comparison of P , PP and PPP phases with synthetics indicates that the 10-Hz energy propagates essentially elastically ($Q > 500$) in the sub-bottom. However, changes in frequency content in the broad-band data with successive traverses of the sub-bottom suggest that Q in the sub-bottom must be frequency dependent. Forward modeling of the broad-band data is quite difficult due to periodicities in the data which vary from shot to shot. Applying a relative wave-form analysis procedure, one can estimate an average differential attenuation operator for the sub-bottom. For PP phases we obtain $Q = 70$ for frequencies above 32 Hz, and for PPP phases we obtain $Q = 175$ above 18 Hz. Due to the insensitivity of the relative wave-form analysis to absolute amplitudes, the frequency dependence of Q is not well resolved from the broad-band data. However, the long-period data, for which absolute amplitude

was modeled, demand a frequency-dependent Q .

An alternative explanation of the multiple-P data is that high-frequency scattering is more of a controlling factor than Q . Possible approaches of generating synthetics for laterally varying structures were discussed. The most promising appear to be numerical-analytical interfacing techniques where one carries the field across the ocean analytically. This approach has not been tried on Professor Raitt's data sets, but clearly the quality of his observations would still merit a few more Ph.D. modeling studies.

Acknowledgments

I thank John Vidale for computing the finite-difference files displayed in this paper, and Cindy Arvesen for helping to get it into final format.

References

- Barker, J., and D. Helmberger. 1986. A broad-band study of attenuation in ocean bottom sediments. Chapter in *Ocean-Seismo Acoustics*, edited by D. Okal. Wiley & Sons.
- Davies, H. 1954. The reflection of electromagnetic waves from a rough surface. *Proc. Inst. Elect. Engrs.*, 101, part 4:209-214.
- Helmberger, D., G. Engen, and P. Scott. 1979. A note on velocity, density, and attenuation models for marine sediments determined from multi-bounce phases. *J. Geophys. Res.* 84:667-671.
- Mitzner, K. M. 1967. Numerical solution for transient scattering from a hard surface of arbitrary shape-retarded potential technique. *J. Acoust. Soc. Am.* 42:391-397.
- Scott, P., and D. Helmberger. 1983. Applications of the Kirchoff-Helmholtz integral to problems in seismology. *Geophys. J. Roy. Astr. Soc.* 72:237-254.
- Scott, P., and D. Helmberger. 1985. Applications of the transmitted Kirchoff-Helmholtz method to transmitted body waves and possible structural effects phases. *J. Geophys. Res.* 84:667-671.
- Shor, G. G., Jr. 1964. Structure of the Bering Sea and the Aleutian Ridge. *Mar. Geol.* 1:213-219.
- Stead, R. J., and D. V. Helmberger. 1987. Numerical-analytical interfacing in two dimensions with applications to modeling NTS seismographs. (In press).

THE DEVELOPMENT OF SEISMIC-REFRACTION TECHNIQUES IN THE SOUTHERN CALIFORNIA BORDERLAND

R. M. Kieckhefer

Chevron U.S.A. Inc.
P.O. Box 5042
San Ramon, CA 94583

B. J. Russell

Marathon Oil Company
P. O. Box 269
Littleton, CO 80160

and

A. S. Meltzer

Department of Geology and Geophysics
Rice University
P. O. Box 1892
Houston, TX 77251

Abstract

The Southern California Borderland is a region of differing tectonostratigraphic terranes juxtaposed by Neogene transcurrent faulting. For the past 40 years, earth scientists have used the seismic-refraction technique to attempt to identify crustal types. Early measurements were made with two ships, large explosive charges, and relatively sparse collection of analog data. More recently, tens of sonobuoy receivers have been used by one ship, firing a large airgun array, to generate much larger quantities of digital data. The improvements in data density have led to a refinement of the velocity models for the various tectonic blocks, though in places the newer data have not resolved refractors as deep as was possible with large explosive sources.

Introduction

The southern California continental margin (Figure 1) is a zone of tectonic blocks which have been juxtaposed in a regime of strike-slip faulting which has dominated the region since the impingement of the East Pacific Rise with the margin about 29 Ma (Atwater, 1970; Graham and Dickinson, 1978; Dickinson, 1983; Legg, 1980). One clue to the evolution of this continental margin is in the crustal structures of the individual tectonic blocks. Despite almost 40 years of study, the crustal structure of the margin offshore

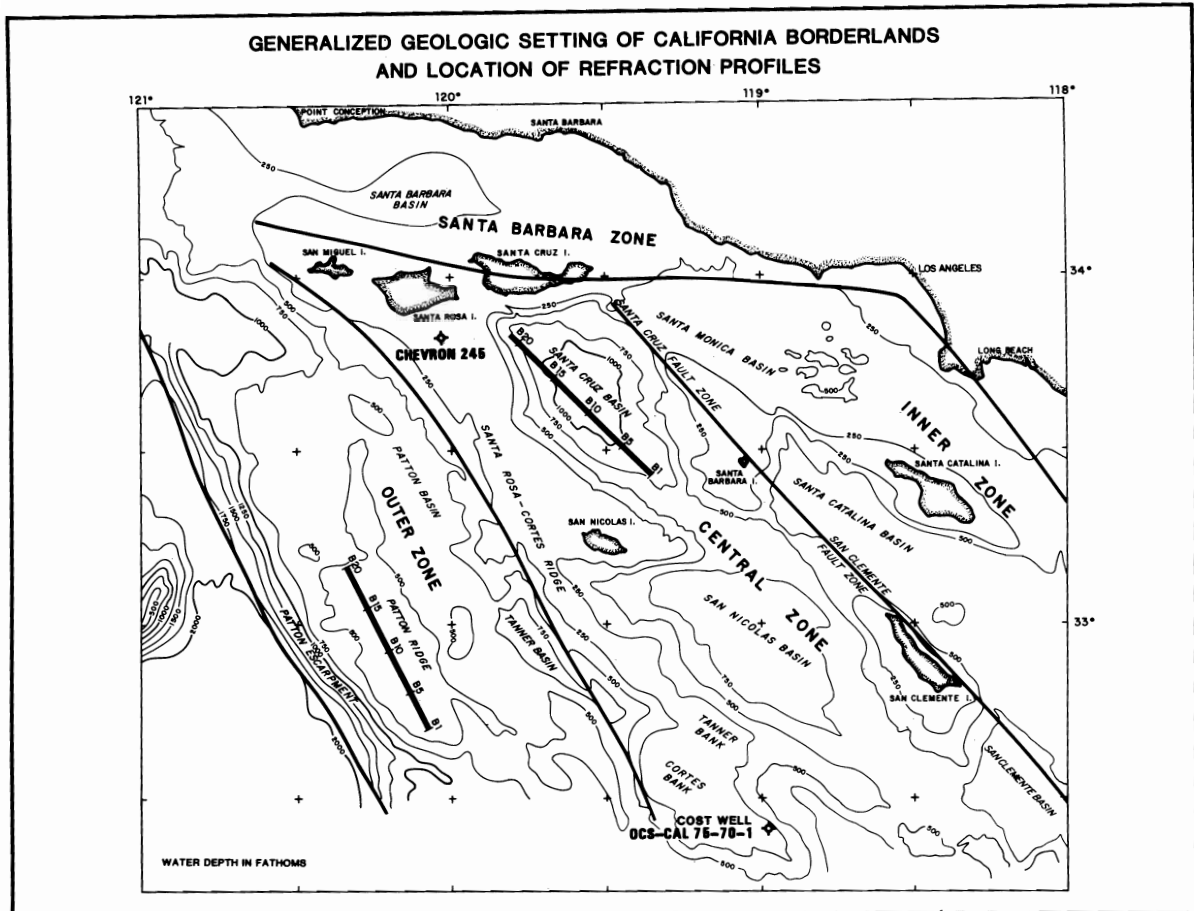

Figure 1. General geologic setting of the Southern California Borderland (after Howell and Vedder, 1981) showing locations of refraction lines shot by Russell *et al.* (1987), wells, and major topographic features. Water depths in fathoms.

today remains largely an enigma. In this paper, we will review some of the methods which have been employed in the attempt to unravel borderland crustal structure.

Historical Background

The study described by Russell *et al.* (1987) was part of a regional tectonic study of California, initiated when the authors were at Gulf Research and Development Co., Harmorville, Pennsylvania. It was at this same research laboratory that Victor Vacquier developed the flux-gate magnetometer in the 1930s.

As part of our regional tectonic study, we realized that we needed information on crustal structure, particularly in the Southern California Borderland. After a lengthy literature search, we found that most of the seismic velocity information available had been collected by Russ Raitt, George Shor, and many other Scripps scientists, between 1949 and 1974 (Shor *et al.*, 1976). A few additional sonobuoy refraction lines were collected by Crouch *et al.* (1978) in preparation for the Deep Sea Drilling Project's *Glomar Challenger* drilling of the borderland on Leg 63.

The detailed work by Russ Raitt and colleagues has been summarized by Shor *et al.* (1976). Over the 25-year period, and particularly in the 1950s, they shot about 50 seismic-refraction lines, collecting data on deep-crustal and upper-mantle velocities in many of the region's basins and on a few ridges. These studies were pioneering: at the time, Maurice Ewing and colleagues at Columbia University were the only other group doing marine seismic experiments, developing similar techniques in the Atlantic Ocean (Ewing and Ewing, 1959). Russ and colleagues used their borderland "backyard" to develop methods, and spent

much of the 1960s and 1970s gathering refraction data throughout the Pacific and Indian oceans and their marginal seas.

A few excerpts from Shor *et al.* (1976) will provide insight into these operations in the days before satellite navigation, shipboard computers, and reflection profiling:

- (1) Extract from MPL [Marine Physical Laboratory of the Scripps Institution of Oceanography] Quarterly Reports, 1 April to 30 June 1949, by R. W. Raitt:

"Previous studies of the transmission of refracted waves through the sea bottom ... made use of a motor whaleboat for firing the source bombs. Experience of several cruises demonstrated that this technique was practicable only when restricted to areas near islands or other land points where lee from wind and waves provided sufficient protection for whaleboat operation. Only a small percentage of the time did weather conditions permit operating in the deep ocean beyond the continental slope off California and Lower [Baja] California."

- (2) 18-19 and 23-24 August [1949]; the Santa Rosa Explosions:

"These were shot by SIO in conjunction with the Corona Quarry blast [156,000 pounds of 'Nitramon'] and were recorded on land by [M. A.] Tuve [of Carnegie Institute] ... There were a total of six 1200-lb. shots and six 2400-lb. shots fired in shallow water in Becher's Bay, Santa Rosa Island. Shot number 10, 24 August, was supposed to be fired in deeper water. It was originally placed on a slope and rolled to about 400 fms depth. All shots were TNT and were fired electrically.

"Stations PAT V Run 1 and PAT V Run 2 [19-20 October 1955] have never been worked up for publication, primarily because of sad deficiencies in the 'auxiliary data'. The echo-sounders on the two ships did not work very well in deep water, so that water delay corrections were difficult. Usually when we don't have echo-sounder data, we use the bottom reflections ... from the shooting ship records of the shot marks, and obtain a depth of adequate accuracy for correction. In this case, we were receiving the shot marks through the echo-sounder transducer of the T-441 [a 66-foot former Army cargo and passenger boat], and while it gave passably usable indications of the shot time, it rarely received the bottom echo. In addition, the navigation was only marginal because of overcast. The alleged distance between the two receiving points is one degree of latitude (60 nautical miles; 111 km), but the direct waterwave time from the most distant shot on Run 2, which should be at the reverse point, is 90 seconds (about 135 km). They were lost."

- (3) 23 October [1955]; Run 3, Patton Ridge:

"The intention was to make a long reversed profile on Patton Ridge ... The weather was bad, and the T-441 had considerable difficulties. The ships therefore lay to at San Nicolas Island waiting for the weather to improve. They finally went to a position at the northern end of the ridge, and tried a run. During the run, the T-441 took some extremely heavy rolls, and the gyro compass came out of its mount. According to the ship's log they stayed on course 152° [east from north] for the entire run; a reconstruction of their track from their soundings and the existing charts indicated that they drifted off course radically, and started over the edge of the [Patton] escarpment. When the water depths became so great that it was obvious that they were badly off position, the run was ended.

"Following termination of the shooting run, the T-441 tried to return to start another run. This course was directly into the sea, however, and they obviously could not make it. Instead, therefore, they headed east to San Nicolas Island, came north in the lee of Point Arguello, and then with the weather down to the planned starting point."

- (4) 24 October [1955]; Run 4, Patton Ridge:

"Following the run, both ships were supposed to head for the north point of San Clemente Island, and spend the night in the lee of the island; the PAOLINA-T [an 80-foot former purse seiner] indeed did so. The T-441, however, was unable to use their gyro compass because of

earlier damage, and only discovered in the middle of the night that they had a 20 degree error in their magnetic compass (caused by the proximity of the magnet in a Brush [seismic] recorder, which had been stowed beneath the compass). As a result, they rounded the north end of Catalina Island instead, and spent the night at Avalon."

Despite these hardships, the work of Raitt and his colleagues produced valuable measurements of crustal and upper-mantle seismic velocities. These measurements probably will stand for many years, due to current restrictions on using large explosive charges in the waters off California.

Two-ship Refraction, Explosive Sources

Some of the most significant geophysical data published to date from the borderland are refraction profiles acquired by Raitt and Shor from the late 1940s to the early 1970s (Shor *et al.*, 1976). In their work, they used wartime-surplus explosives as seismic sources and hydrophones suspended from floats wired to ships as receivers. A second vessel was used to deploy explosives. As noted above, navigation was poor, by modern standards, and frequently the refraction lines crossed uncharted sea-floor topographic irregularities which would make interpretation of the data difficult, if not impossible.

In the 1940s and 1950s, the Scripps scientists typically started each refraction line by firing small explosive charges, one pound or less, at short ranges, and then increased the charge size to 100 or even 200 pounds at longer ranges, in order to keep the refraction signals at roughly the same level as the background noise (or, in occasional moments of extravagance, somewhat higher than the noise). These techniques provided a seismic trace every 1-3 km, approximately, at short shot-receiver ranges, and every 5-10 km, approximately, at longer ranges (Figure 2). The limitation at longer ranges was caused by a need to conserve explosives rather than a lack of interest in records spaced more closely.

Figure 2. Refraction line shot in 1949 in Santa Cruz Basin, from Shor *et al.* (1976). Top, data (first arrivals picked from analog records); bottom, delay-time interpretation, assuming 2.8- and 6.2-km/s layers. The left (north) half of this diagram models the same region as buoys 2-15 of Figure 6.

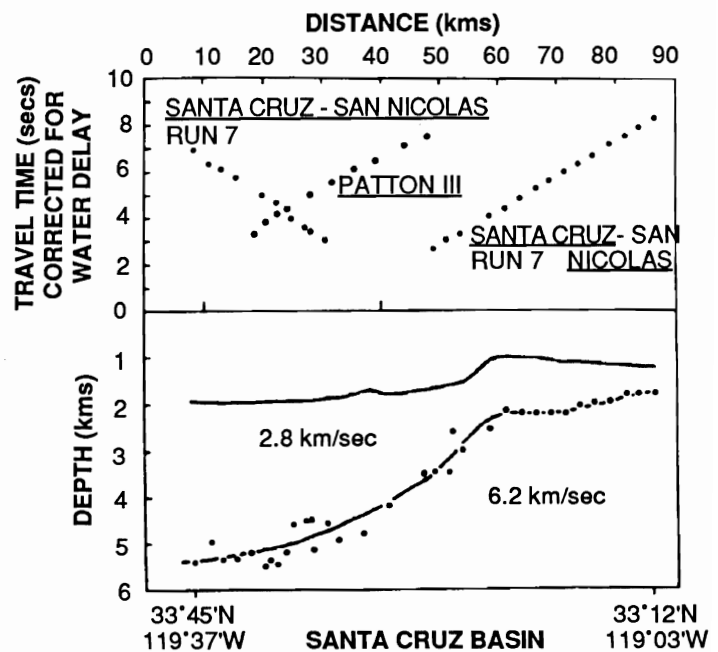

The data were recorded in analog form aboard the receiving ship, and were plentiful enough to be fit to plane-layer models. One of the advantages of using two ships was that the data were closely monitored, and if the personnel dutifully recorded the amplifier settings used in receiving each shot, they could get a good estimate of the relative acoustic signal reaching the hydrophone. Occasionally (Spudich and Orcutt, 1980a), the data were worthy of being digitized (after digital computers were invented) and analyzed in more detail than the plane-layer models.

Despite the limitations, Raitt and Shor's early experiments showed the offshore Southern California Borderland to be a composite of crustal types, with basement velocities ranging from 4.8 to 6.9 km/s.

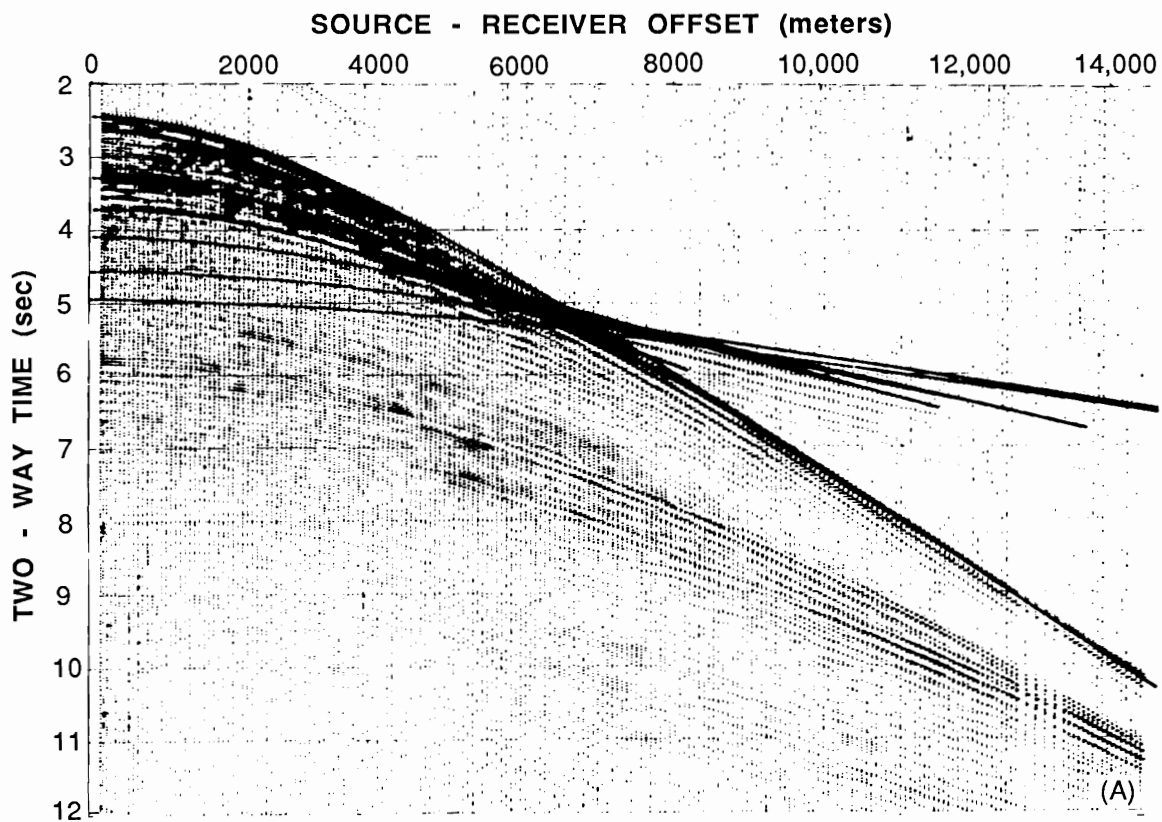

Figure 3. Sonobuoy 9, Santa Cruz Basin refraction line of Russell *et al.* (1987): conventional $x-t$ data with interpretation. This was one of 17 working sonobuoys on this line. Dashed lines in interpretation are pre-critical reflections; solid lines are post-critical.

Some basins (for example, San Nicolas Basin) appeared to be underlain by oceanic crust. Others (for example, San Clemente Basin and Santa Catalina Basin), where refraction data are less conclusive, certainly have different velocities and presumably different compositions, which can be interpreted to have a higher silicic or transitional component.

Isolated Sonobuoys, Explosive Sources

After developing techniques in the borderland, Scripps scientists began studying crustal structure of the entire Pacific Ocean, and the borderland was somewhat neglected. During the 1960s and 1970s, numerous advances in electronics allowed the receiving ship to be replaced by an unmanned sonobuoy which transmitted hydrophone signals to the shooting ship. On their occasional return to the borderland (Shor *et al.*, 1976), Scripps scientists used similar techniques to those employed in two-ship work, obtaining a similar data density (though at roughly half the cost, since only one ship was needed). Most early sonobuoys had some sort of automatic gain-ranging amplifier, however, so that amplitudes of seismic signals could not be recovered and second arrivals were hard to identify. The range of sonobuoys was limited to about 30-50 km, so that refractions could not be obtained from deeper than approximately 10 km. The initial uses of sonobuoys in borderland refraction, then, resulted in little improvement to our knowledge of the crustal structure of the region's tectonic blocks.

Isolated Sonobuoys, Airgun Source

The oil industry and several academic groups (Sutton *et al.*, 1971; Knott and Hoskins, 1975; Hamilton *et al.*, 1977; Houtz and Ludwig, 1977) began using sonobuoys in conjunction with airgun sources in the late 1960s, and in the 1970s this combination was introduced into the Southern California Borderland. The major advantage of the sonobuoy-airgun combination was a large increase in data density, with a seismic source whose wave form and energy were reproducible. These factors, when combined with digital-processing techniques, gave investigators much more detailed information about sedimentary refractors. Most sonobuoys were not moored, however, so that interpreters had to assume that geologic structure (especially water depth) remained constant in the area over which the sonobuoy drifted.

The initial use of sonobuoys with airgun sources in the borderland was a series of unreversed refraction profiles shot by the U.S. Geological Survey in 1978 in preparation for DSDP drilling (Crouch *et al.*, 1978). These profiles provided velocity information in Patton Basin, and were used as an aid in interpreting seismic-reflection profiles.

Multiple Sonobuoys, Airgun Source

One of the more recent uses of sonobuoys in the borderland was two refraction profiles shot from the R/V *Hollis Hedberg* to buoys co-linear with previously recorded reflection profiles in Santa Cruz Basin and on Patton Ridge (Russell *et al.*, 1987). Buoys were deployed at 3-km intervals on these lines and the *Hedberg's* 3200-cubic-inch (52-liter) 4500-p.s.i. (31,000-kPa) air gun array was fired every 67 m. The close buoy spacing enabled Russell *et al.* (1987) to reverse up-dip and down-dip refractor segments shot over the same portion of a refracting interface, so that they did not have to assume dips or assume that refractors were continuous and planar over long distances.

Russell *et al.* (1987) performed τ - p (intercept time-ray parameter (dt/dx); see Diebold and Stoffa, 1981) analyses on data from moored buoys in Santa Cruz Basin (Figures 3, 4, 5), in areas of minimal sea-floor and basement topography. These analyses yielded good velocity control for rocks shallower than 4 seconds two-way travel time. Control by x - t analysis was better below 4 seconds because of apparent velocity changes caused by geologic structure, topography, and horizontal velocity gradients. Because their sonobuoys transmitted at a fixed gain, were densely sampled, had high signal-to-noise ratios for sedimentary arrivals, and most were moored, the data set may be useful in studies not pursued by Russell *et al.* (1987), such as ray tracing and tomography.

By shooting their refraction lines over multichannel reflection profiles, Russell *et al.* (1987) could correlate refractors with reflectors, and could correlate velocity changes with unconformities and other seismic-stratigraphic events (Figure 6). This capability was especially valuable in their interpretation of a high-velocity refractor (5400-6400 m/s) in Santa Cruz Basin as volcanic, metasedimentary, or other metamorphic rock, because of its correlation with coherent layered reflectors. They also could compare dips of reversed refractors with dips of associated reflectors, as a check that they were correctly reversing the refractor segments shot up-dip and down-dip.

Future Methods

Refraction seismology continues to evolve new methods for studying the velocity structure of offshore areas. The use of ocean-bottom seismographs (OBS) with 3-component seismometers in the borderland will improve our capabilities for identifying shear waves. More advanced methods of data analysis, as reviewed by Spudich and Orcutt (1980b), will improve resolution of the velocity models.

Conclusions

We have shown how improvements in data-acquisition techniques have improved our knowledge of the crustal structure of selected portions of the Southern California Borderland. In Santa Cruz Basin, in particular, the model has improved from a two-layer model whose highest velocity was 6200 m/s in 1949 (Shor *et al.*, 1976) to a six-layer model, whose layers are correlated with reflectors, with velocities up to

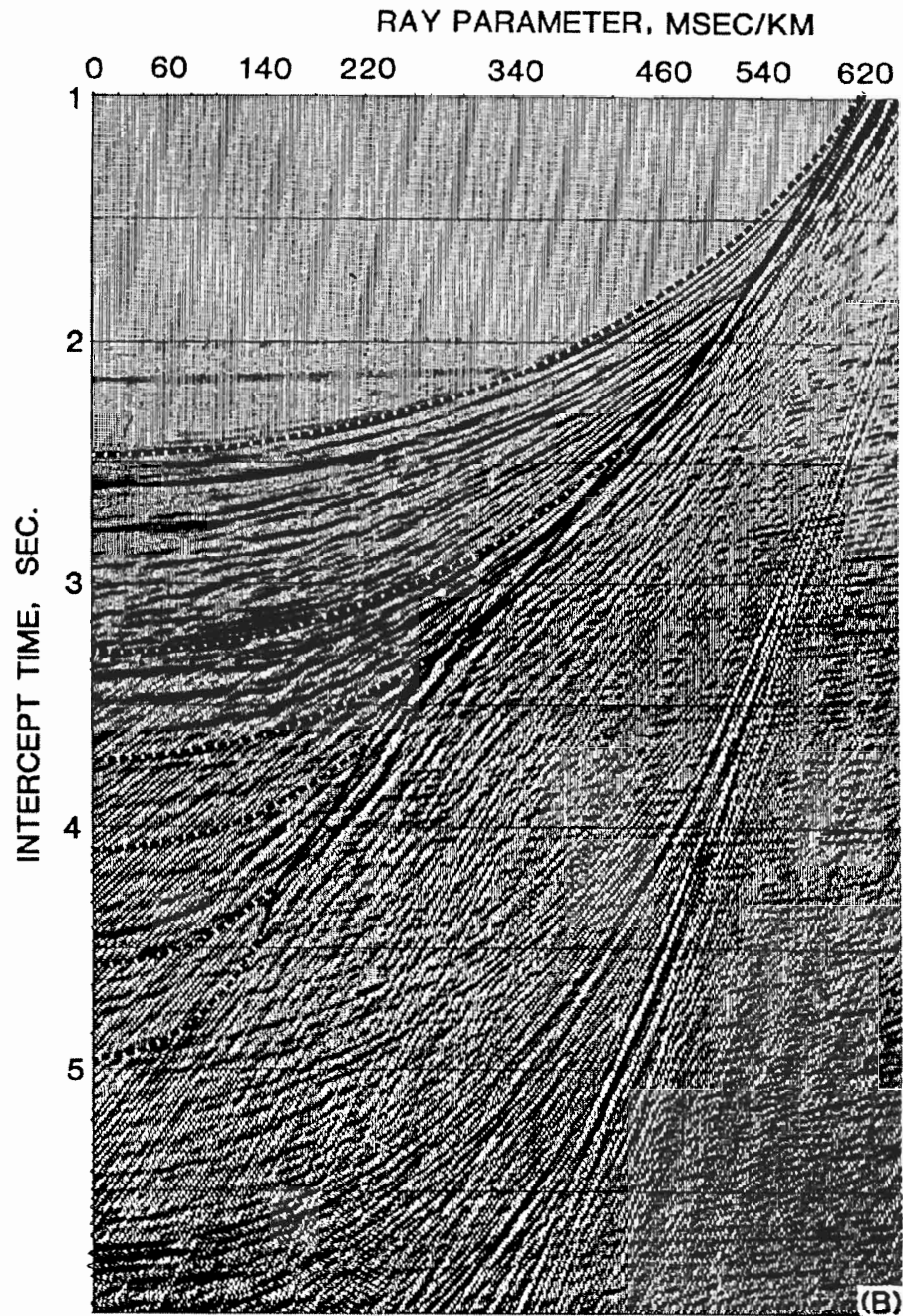

Figure 4. Sonobuoy 9, Santa Cruz Basin refraction line of Russell *et al.* (1987): data transformed to τ - p domain with interpretation (dashed: pre-critical; solid: post-critical).

7200 m/s in 1983 (Russell *et al.*, 1987).

In some cases, though, the improvement has been marginal. On Patton Ridge, the upper layers of the 1949 three-layer model (Shor *et al.*, 1976) have been refined somewhat by Russell *et al.* (1987) by joint analysis and interpretation of reflection and refraction data leading to a more detailed velocity model of the upper ridge structure. The later study, however, did not resolve the deepest layer of the early model, 6200 m/s, perhaps due to the lesser energy of the airgun source used in 1983 compared to the large explosive charges (up to 200 pounds) used in 1949.

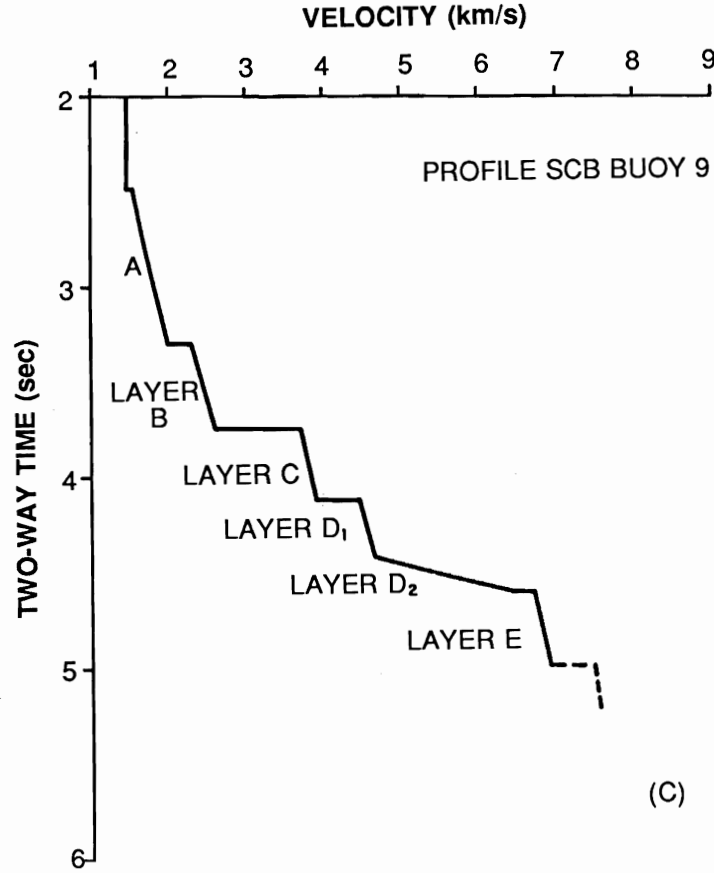

Figure 5. Sonobuoy 9, Santa Cruz Basin refraction line of Russell *et al.* (1987): velocity model derived from τ - p data (Figure 4) and modified by ray-tracing in x - t domain.

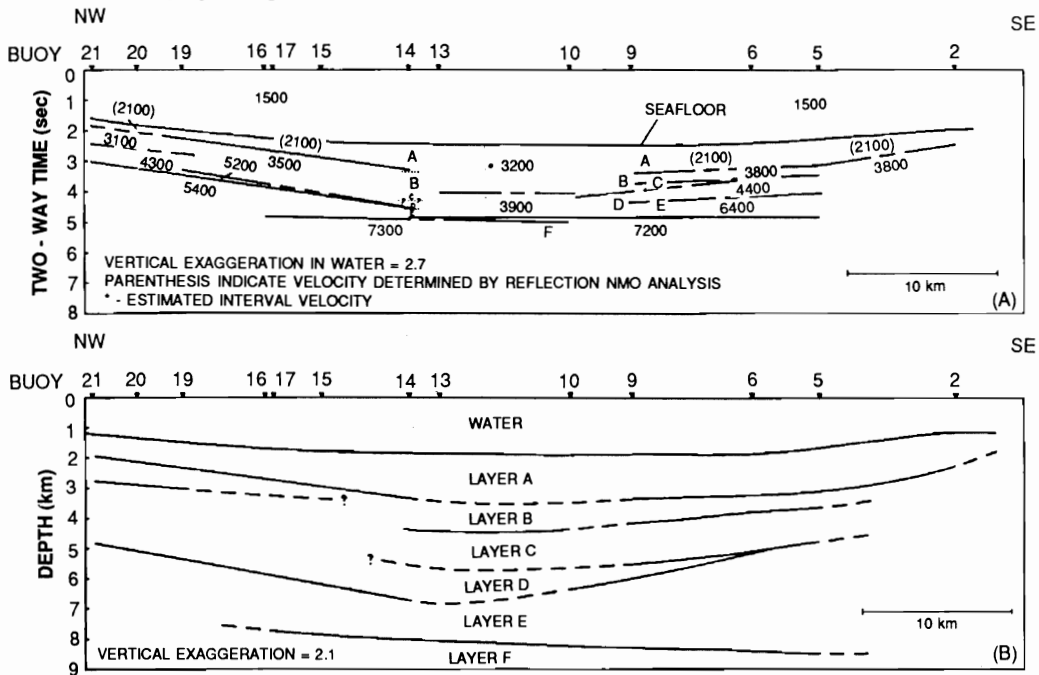

Figure 6. Velocity model along Santa Cruz Basin refraction line: (a) model from reversed refraction analysis of all available pairs of sonobuoys and (b) interpretation of stratigraphic units incorporating refraction and reflection data. Velocities in m/s. The region between buoys 2 and 15 is approximately the same region shown in the left half of Figure 2.

Acknowledgments

We thank the numerous scientists with whom we have worked on California tectonics over the years, especially D. B. Jovanovich. We are grateful to Chevron U.S.A. Inc., and Chevron Oil Field Research Company for granting us permission to publish this review.

References

- Atwater, T. 1970. Implications of plate tectonics for the Cenozoic tectonic evolution of western North America. *Bull. Geol. Soc. Am.* 81:3513-3536.
- Crouch, J. K., M. L. Holmes, T. H. McCulloh, A. T. Long, and R. H. Brune. 1978. Multichannel seismic reflection and sonobuoy refraction data in the outer Southern California Borderland. *U. S. Geol. Surv. Open File Rep.* 78-706.
- Dickinson, W. R. 1983. Cretaceous sinistral strike-slip along Nacimiento fault in coastal California. *Bull. Am. Assoc. Petrol. Geol.* 67:624-645.
- Diebold, J. B., and P. L. Stoffa. 1981. The travelttime equation, τ -p mapping, and inversion of common midpoint data. *Geophysics* 46:238-254.
- Ewing, J., and M. Ewing. 1959. Seismic refraction measurements in the Atlantic Ocean basins, in the Mediterranean Sea, on the Mid-Atlantic Ridge, and in the Norwegian Sea. *Bull. Geol. Soc. Am.* 70: 291-318.
- Graham, S. A., and W. R. Dickinson. 1978. Evidence for 115 kilometers of right slip on the San Gregorio-Hosgri fault trend. *Science* 199:179-181.
- Hamilton, E. L., R. T. Bachman, J. R. Curray, and D. G. Moore. 1977. Sediment velocities from sonobuoys: Bengal Fan, Sunda Trench, Andaman Basin, and Nicobar Fan. *J. Geophys. Res.* 82:3003-3012.
- Houtz, R. E., and W. J. Ludwig. 1977. Structure of the Columbia Basin, Caribbean Sea, from profiler-sonobuoy measurements. *J. Geophys. Res.* 82:4861-4867.
- Howell, D. G., and J. G. Vedder. 1981. Structural implications of stratigraphic discontinuities across the Southern California Borderland. In *The Geotectonic Development of California*, Rubey vol. 1, edited by W. G. Ernst, pp. 535-558. Prentice-Hall.
- Knott, S. T., and H. Hoskins. 1975. Collection and analysis of seismic wide angle reflection and refraction data using radio sonobuoys. *Tech. Rep. WHOI-75-33*, Woods Hole Oceanogr. Inst., Woods Hole, MA.
- Legg, M. R. 1980. Seismicity and tectonics of the inner continental borderland of southern California and northern Baja California, Mexico. M.S. thesis, Scripps Inst. Oceanog., La Jolla, CA.
- Russell, B. J., A. S. Meltzer, R. M. Kieckhefer, and A. R. Levander. 1987. Crustal structure of the Santa Cruz Basin and Patton Ridge, outer California borderland. *J. Geophys. Res.* In press.
- Shor, G. G., Jr., R. W. Raitt, and D. D. McGowan. 1976. Seismic refraction studies in the Southern California Borderland, 1949-1974. *Scripps Inst. Oceanog. Ref.* 76-13:70 pp.
- Spudich, P., and J. A. Orcutt. 1980a. Petrology and porosity of an oceanic crustal site: Results from waveform modeling of seismic refraction data. *J. Geophys. Res.* 85:1409-1433.
- Spudich, P., and J. A. Orcutt. 1980b. A new look at the seismic velocity structure of the oceanic crust. *Rev. Geophys. Sp. Phys.* 18:627-645.
- Sutton, G. H., G. L. Maynard, and D. M. Hussong. 1971. Widespread occurrence of a high velocity basal layer in the Pacific crust found with repetitive sources and sonobuoys. In *The Structure and Physical Properties of the Earth's Crust*, edited by J. G. Heacock, Geophys. Monogr. 14. Am. Geophys. Union.

THE SOURCE OF MARINE MAGNETIC ANOMALIES

Christopher G.A. Harrison

*Rosenstiel School of Marine and Atmospheric Science
University of Miami
Miami, FL 33149*

Introduction

It was a great pleasure for me to be invited to help plan the symposium celebrating the fortieth anniversary of the Marine Physical Laboratory, and the eightieth years of Russell Raitt and Victor Vacquier. The pleasure was doubly enhanced for me because of my close association with Victor Vacquier during the time at SIO and MPL and afterwards, and because of my family relationship with Russell Raitt. These two geophysicists were in large part responsible for the new and stimulating research done in marine geophysics by Scripps during the 50's, 60's and 70's. One experiment performed by Russell Raitt was described to me many years ago as one of the most significant experiments in marine geophysics during the decade (Robert Dietz, pers. comm.). This was the experiment verifying the anisotropic nature of the oceanic mantle (Raitt *et al.*, 1969).

Another very important aspect of Russell's work was the painstaking field notes which accompanied each experiment. The quality of data that he collected with surface hydrophones has rarely been bettered, even with ocean-bottom seismometers. Thus when people wish to do very careful modelling of marine seismic experiments they often turn to his data (Spudich and Orcutt, 1980). These Fanfare Expedition data are still being used today for more sophisticated modelling efforts (Bullwinkel, 1987). Ironically, Russell confessed to me that the Fanfare data were very atypical as they demonstrated so well the uniform layered nature of the oceanic crust much better than most other seismic stations.

Victor Vacquier trained me to think deeply about data. He was never satisfied with a pure description of a phenomenon, a method of operation common in a newly developing field such as marine geophysics, but always wished to know the meaning of the observations. His interest in the source of magnetic anomalies was an inspiration to me when I first became interested in this subject, and some very early work still remains interesting and controversial (Vacquier and Affleck, 1941). In my own work on the source of long wavelength anomalies, I have had occasion to refer to this early paper (Harrison, 1987a).

Vacquier's interest in magnetic anomalies is shown by the large number of papers that he published on this topic (*e.g.*, Vacquier *et al.*, 1951). Of equal importance was his design of the first instrument used to measure the strength of the magnetic field routinely at sea, the flux-gate magnetometer, for which he was awarded a patent in 1946. One peculiar feature about the flux-gate magnetometer eventually used for marine operations (a modified airborne device) was that, in order to measure total field, two of the three orthogonal sensors were rotated to give zero field, implying that the third sensor was aligned along the field vector, and so measuring its modulus. Much more recently, a three-component flux-gate magnetometer was put on board MAGSAT for vector field measurements, which of course required accurate orientation. However, the orientation devices had some instrumental problems, which prevented the accurate measurement of the vector components for large portions of the mission. Since the scalar magnetometer, an optically pumped vapor magnetometer, also did not work completely satisfactorily, the results from the flux-gate magnetometer were vectorially combined to give a total field modulus, the usual quantity used for studying crustal anomalies. We have thus by chance come back to the old airborne flux-gate magnetometer, used to give total field strength.

One of the paradigms of the modern scientific method is to search for ways of refuting scientific hypotheses. This is an extreme example of our need either to confirm or disprove hypotheses. The hypothesis that I wish to discuss is the Vine-Matthews hypothesis (1963), which suggests that oceanic rocks become polarized in the direction of the magnetic field at the time of their formation, thus recording the polarity history of the Earth's magnetic field and producing, by the process of sea-floor spreading, the

lineated magnetic anomalies to be found on either side of mid-oceanic ridge crests. By a study of the strength of the magnetic anomalies so formed, it should be possible to obtain an idea of the strength of the magnetization.

Early Observations of Marine Magnetic Anomalies

One of the first papers to discuss magnetic anomalies observed over the ocean basins was that of Allredge and Keller (1949). Airborne total magnetic field observations were made between Alaska and the Marshall Islands. The authors suggested a region of reverse polarization, because they realized that a characteristic positive anomaly surrounded by negative anomalies at a low latitude indicated a source with polarity opposite to that of the present Earth's field. The instrument used was a flux-gate magnetometer.

One of the disadvantages of airborne measurements is that no bathymetric information is gathered. Thus Allredge and Keller (1949) were unable to determine anything about their proposed reversely magnetized source because they did not know what it was. For this reason, a marine version of the flux-gate magnetometer was developed, and used by Heezen *et al.* (1953) to study the magnetic field between Dakar and Barbados, along with topographic results. Not much of interest came from this study or from many other observations of the marine geomagnetic field until the observation of the striking magnetic lineations in the northeast Pacific Ocean (Mason and Raff, 1961; Raff and Mason, 1961). Early work by Menard and Vacquier (1958) showed the lineations and also identified the offsets of these lineations across the eastern portion of the Murray Fracture Zone, a forerunner of the papers by Vacquier which documented in greater detail many of the offsets of anomalies across the fracture zones in the northeastern Pacific (*e.g.*, Vacquier, 1965).

One of the earliest serious attempts to study marine magnetic anomalies was that of Girdler and Peter (1960) who performed calculations which suggested the presence of igneous rocks of reverse magnetization. Unfortunately, the calculations were not presented in enough detail to allow an independent evaluation of this claim to be made.

The Vine-Matthews Hypothesis

This hypothesis (Vine and Matthews, 1963) supposes that rocks under the ocean basins acquire their magnetization during cooling from a magma in the direction of the Earth's field at the time of the rocks passing through the blocking temperature. Sea-floor spreading, coupled with reversals of the field, produces bands on either side of the ridge crest where the magnetization is constant. If spreading is symmetric on either side of the ridge crest, then the bands are also symmetric, although the pattern of magnetic anomalies is not necessarily so, because of the phase shifting of the anomalous field with respect to the underlying magnetization (Schouten and McCamy, 1972). At about the same time, Morley attempted to publish essentially the same ideas, but was turned down by several major scientific journals. His paper was eventually published in *The Sea*, volume 7 (Morley, 1981), and a description of the steps which led to his ideas has been briefly given recently (Morley, 1986).

Ideas of scientists about the exact location of the magnetized rocks responsible for the lineated magnetic anomalies have undergone significant changes through time. Blakely (1983) briefly summarized the evolution of these ideas in a table, and some of this material has been extracted and presented as Table 1. Today, opinions regarding the source of marine magnetic anomalies seem to fall between those who believe that the top 0.5 km of the oceanic crust, which can be equated with the pillow-lava layer of ophiolites, is the sole source, and those who believe that the whole of the oceanic crust is necessary to produce the observed magnetic anomalies. The origin of the 0.5-km layer is the paper by Talwani *et al.* (1971). Larger thicknesses have been required by those who believe that the pillow layer may have too many reversals in vertical section to be responsible for the magnetic anomalies, or who believe that the strength of magnetization in this layer is not sufficient to cause the observed amplitudes of magnetic anomalies.

Blakely (1983) has given an interesting analogy between magnetic observations of Vine-Matthews lineations and a normal tape-recording process. The Earth's field is the original signal which is to be recorded. It is ideally imagined to be a square wave, oscillating between two stable states of equal amplitude but opposite sign. There are of course amplitude variations of the field within the states of constant polarity, and also the reversal process does not occur over an infinitely short time period, but as a

TABLE 1

A Summary of Concepts About the Source of Marine Magnetic Anomalies

Publication Date	Authors	Layer Thickness, km	Significance
1- 1958	Mason	2.5	Suggested importance of remanence and showed anomalies are linear (N.E. Pacific)
2- 1960	Girdler and Peter	15	Modeled anomalies with remanent magnetization (Gulf of Aden)
3- 1963	Vine and Matthews	20	Suggested marine anomalies caused by sea-floor spreading
4- 1965	Vine and Wilson	8	Correlated anomalies with reversal time scales, 0 to 3 mybp; correlated anomalies from ocean to ocean
5- 1971	Talwani	0.4	Suggested magnetic layer is seismic layer 2A
6- 1976	Cande and Kent	4	Suggested reversal boundaries have shape of sloped Curie-point isotherm
7- 1977	Kidd	4	Proposed a three-layer model
8- 1979	Schouten and Denham	0.5	Proposed a blob-intrusion model for upper part of magnetic layer

first order model it is not unreasonable. The crustal recorder records this reversal process, at the same time adding noise, such that the crustal record will look like a square wave onto which noise has been superimposed. Finally the Earth filter (Schouten and McCamy, 1972) filters this signal and produces the observed magnetic field anomaly, seen at the ocean surface. The Earth filter is a band-pass filter, which also phase shifts individual spectral estimates by the same fraction of a wavelength. If we could accurately measure the characteristics of the Earth filter, our problem would be solved; but, unfortunately, the filter is only weakly dependent upon the thickness of the source layer, and it appears unlikely that we shall be able to measure the characteristics accurately enough to determine the thickness of the source layer using this method. The alternative is to realize that the amplitude of the anomalies is more or less dependent upon the thickness of the layer multiplied by the magnetization intensity; so, if we can determine the magnetization intensity, then the thickness of the layer can be established. This is the method that will be used in this paper.

Inversions of Magnetic Anomalies

There have been literally thousands of observations of magnetic anomalies which could potentially be used to determine the magnetization intensity of the oceanic crust as a function of the thickness of the model of magnetization of oceanic crust used in the inversion process. However, relatively few actual inversions have been performed. Some notable examples of inversions used to model crustal magnetization are those using the Scripps Deep Tow (Klitgord *et al.*, 1975). Results are given in Table 2. Although Klitgord *et al.* did their inversions assuming a 0.5-km thick layer for the magnetized portion of the oceanic crust, the results shown in Table 2 have been normalized to a 6-km thick layer using the method given by Harrison (1987b). This normalization has to be done with care, because for the Deep Tow the statement that magnetization is inversely related to thickness is not correct, the reason being that the Deep Tow is so close to the upper layer of the oceanic crust. It can be seen that the magnetization necessary to explain the Deep Tow data is roughly 2 A/m. Results of inversion of surface observations of the field give results which are comparable to this (Harrison, 1976; 1987a; 1987b). The magnetization so obtained from inversions is a minimum one because components of magnetization which are aligned in the direction of the lineations cannot be measured. In most cases, the increase in magnetization after having allowed for this will not be very large, because most observations have been done where the anomalies are well developed, which automatically biases against areas such as the equatorial Atlantic, which are close to the equator with the lineations running north-south.

Location	Magnetization A/m (assuming a 6-km thick layer)
Juan de Fuca	2.66
Pacific Antarctic	1.76
Gorda	1.65
East Pacific	2.15
Costa Rica	0.94
Mean	1.83
Standard Error	0.28

There are of course other methods of determining the magnetization of the oceanic crust indirectly, using magnetic field observations. One method which has recently become available is by using the data collected by MAGSAT, which was launched into an approximately polar orbit late in 1979. It lasted longer than its design lifetime of six months, and provided us with a first global picture of the long wavelength components of the Earth's magnetic field. A preliminary analysis of a portion of the signal received by MAGSAT was done by Harrison *et al.* (1986) who inverted the spherical harmonics of magnetic potential believed to be caused by crustal sources. The inversion process involved determination of spherical harmonics of vertical dipole moment per unit area of a presumed source function consisting of a thin magnetized shell. The spherical harmonics of dipole moment per unit area are simply related to spherical harmonics of magnetic potential (Chapman and Bartels, 1940; Harrison *et al.*, 1986). When this function is analyzed for oceanic regions, the root mean square value of dipole moment per unit area, divided by a presumed magnetic layer thickness of 6 km, gave a magnetization value of 1.15 A/m. This is a minimum magnetization because it does not take into account short wavelength features of the field which become averaged out at satellite altitude; this of course includes almost all of the signal from typical

sea-floor spreading anomalies, whose wavelengths of less than 200 km are filtered out by the 350-km elevation of the satellite. Another reason why this is a minimum magnetization is that there are certain magnetization patterns within a source region which do not produce any external magnetic field. A simple example is a uniform magnetization in an infinite horizontal slab, which has no external field. Parker and Huestis (1974) derived an expression for the magnetization which cannot be seen, for the case of topography which is lineated in the direction of constant magnetization. This magnetization they called the annihilator. Annihilators exist for more complex structures. For instance, in the case of a magnetized spherical shell, an annihilator is a magnetization within the shell which is linearly related to any field source within the inner surface of the shell (Runcorn, 1975; Harrison *et al.*, 1986). A third reason why the magnetization obtained by inversion of MAGSAT-derived potential coefficients is a minimum is that there are undoubtedly magnetizations which have longer wavelengths than the degree 14 harmonic, this being the lowest degree of coefficient in the inversion process. The lower degrees of harmonic coming from crustal sources are swamped by core sources. Langel and Estes (1982) show the values of the Lowes-Mauersberger function for MAGSAT data. They give a formula for the variation of the crustal component of the power between spherical harmonics 14 and 23 which shows a slightly red spectrum (i.e., more power at lower degrees of harmonic). If we assume that the power for the crustal component is white, and take the value of the 14th degree of harmonic from Langel and Estes (1982) to represent this white spectrum, it is an easy matter to calculate the effect of the missing lower degree harmonics on the value of the magnetization. Harmonics between 13 and 9 give the same root mean square value of magnetization as do the harmonics between 14 and 23. Below harmonic 9 the effect rapidly increases. It therefore seems probable that the value of 1.15 A/m should be at least doubled to account for the missing lower degrees of harmonic.

On a more sophisticated level of inversion, Hayling and Harrison (1986) have inverted MAGSAT data over the northern and equatorial Atlantic Ocean in order to obtain an equivalent source model for the magnetic anomalies (Figure 1). Details of how this map was created are given by Harrison *et al.* (1986) and Hayling and Harrison (1986). It can be seen that the general level of magnetization for the crust, which was assumed to be 6 km thick, is several A/m. Several features of this map indicate that it is providing a reasonable model of magnetizations. Firstly, it reproduces lineated magnetizations produced by the Cretaceous period of long normal polarity in the North Atlantic, as two stripes of positive magnetization which have amplitudes above background of about 3 A/m. Secondly, there are regions where the magnetization appears to be very low, and some of these are associated with regions of very thick sediments such as the Amazon, Congo and Laurentian cones. Hayling and Harrison (1986) have shown that the sediment in these cones is thick enough to cause the temperature of almost all of the oceanic crust to be above its Curie temperature, thus removing any strong remanent or induced magnetization.

Direct Observations of Magnetization

We now wish to compare these indirect results with observations made of candidate rocks for the oceanic crust. These rocks come from three sources, all of which have advantages and disadvantages as models of the oceanic crust. The first type of rock is dredged from the ocean floor. Rocks of this nature come from unsedimented areas, which means that they are restricted to fairly young ages or from fracture zones. However, the type of rock recovered using this method has a wide variety, especially from fracture zones, which allow deeper layers of the oceanic crust to be made available at the surface (Bonatti and Honnorez, 1976). The second type of rock comes from drilling, and can be of widely varying age, although very thick sediment piles for older areas of the oceanic crust usually limit these rocks to being younger than a few tens of millions of years old. One disadvantage is that the depth of penetration has limited rocks to layers 2A (pillows) or 2B (sheeted dike complex), so that almost nothing is known of the rocks from layer 3 using this method. The third type of rock comes from sections of the oceanic crust obducted onto land, in ophiolite complexes. These give complete sections of the oceanic crust, but the disadvantage here is that the process of obduction may have produced alterations in the magnetic properties of the rocks so that they no longer represent this situation in the true oceanic crust. Levi *et al.* (1978) have set forth a series of criteria whereby ophiolite results may be used to infer the magnetic properties of the oceanic crust. We have used these criteria to winnow the ophiolite data.

The compilation of data from all rock collections for various rock types is given in Table 3 (from Hayling and Harrison, 1986). In order to arrive at a model for the whole oceanic crust, we compile these data to make up representative values for each layer of the oceanic crust. Layer 2A is the layer of pillow lavas, and is taken to be 0.5 km thick. For this layer we have taken 45% of the DSDP basalt result, 45% of

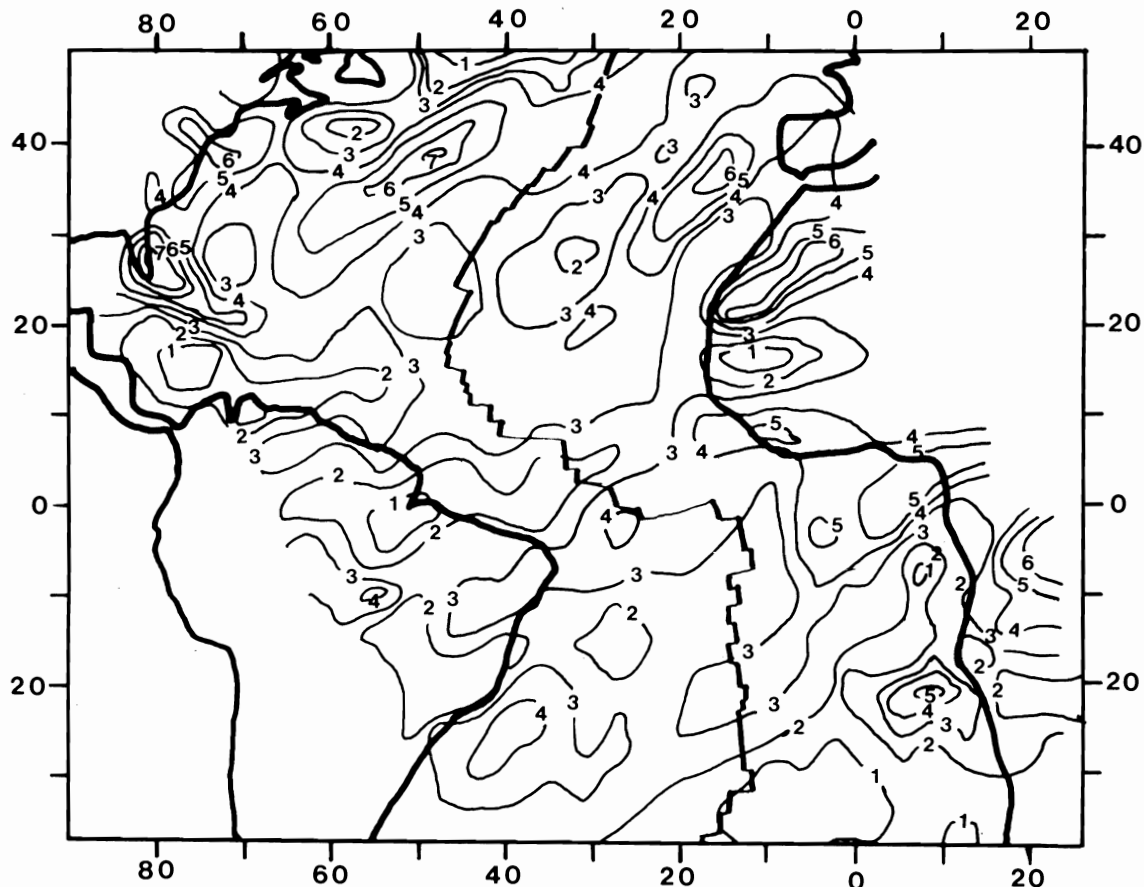

Figure 1. Magnetization model for the northern and equatorial Atlantic (from Hayling and Harrison, 1986). All magnetizations have been made positive by use of an annihilator.

the dredge result and 10% of the metamorphosed result. Since the dredged basalt result gives a much greater natural remanent magnetization (NRM) than the other three basalt types, we feel that a 45% share is probably going to give an overestimate of the total magnetization in layer 2A because the dredged result is biased towards very young rocks whose magnetization will probably decay greatly with a time constant of about 5 million years (Raymond and LaBrecque, 1987; Bleil and Petersen, 1983). For layer 2B, the sheeted dike complex, we have taken 90% of the ophiolite result and 10% of the metamorphosed result. Many people believe that the sheeted dike complex is fairly highly metamorphosed, so that taking only 10% of the metamorphosed result, with its very low NRM, will also give an estimate for the magnetization of the layer which will tend to be on the high side.

Layer 3 is generally believed to consist predominantly of gabbroic rocks. The presence of significant quantities of peridotite, usually serpentinitized, in dredge hauls and occasionally sampled by drilling, indicates that there is probably some serpentinite in this layer, although the amount is almost certainly less than 15%. The ophiolite model of the oceanic crust calls for an upper homogeneous gabbroic layer, formed by chilling onto the cool roof of the magma chamber, and a lower cumulate layer, formed by crystal settling within the body of the magma. Descriptions of the rocks used in paleomagnetic analysis are usually not complete enough to enable us to separate them into these two groups, so we have been forced to treat layer 3 as one. In any case, current models do not give reliable estimates of the relative thicknesses of these two parts of layer 3. Our result from layer 3 is made up of 45% of the ophiolite result, 22.5% of the unaltered dredge result, 22.5% of the metamorphosed dredged result, and 10% of the serpentinite result. Notice that since the NRM results for the four compilations of rocks from layer 3 are relatively close, the actual percentages used do not grossly affect the final result, unless one were to choose 100% of one compilation. In addition to the serpentinitized gabbro, we have also allowed for a 0.5-km thick layer of serpentinitized peridotite which could potentially carry a long wavelength signal, made up of 50% each of the two entries in the table. Because this rock type has a much larger NRM than any other rock type

TABLE 3
Magnetization of Oceanic Rocks
(from Hayling and Harrison, 1986)

	N	NRM A/m	N	Induced Magnetization A/m in 40,000nT
Basalt				
1. Ophiolites	208	0.342	208	0.337
2. DSDP	122	2.64	122	0.470
3. Dredge	309	5.37	309	0.163
4. Metamorphosed	16	0.0122	16	0.007
Gabbro				
5. Ophiolites	257	0.478	257	0.101
6. Unaltered	31	0.621	31	0.403
7. Metamorphosed/ cataclastic	47	0.894	47	0.593
8. Serpentinized	6	0.48	6	0.154
Serpentinized Peridotites				
9. Ophiolites	38	6.03	38	0.485
10. Dredged/Drilled	28	4.15	27	0.887

believed to be a candidate for layer 3, addition of small percentages of it can have a large effect on the average magnetization for this layer. We have effectively used a layer 3 which contains 11% of serpentinized peridotite.

Discussion

The average magnetization of a 6-km thick oceanic crust is 1.18 A/m. This is of the right order of magnitude of magnetization obtained from inversion of magnetic anomalies, either surface data, Deep Tow data or satellite observations. If it is supposed that the layer causing the magnetic anomalies is in reality only 0.5 km thick (i.e., layer 2A) or 1.5 km thick (the whole of layer 2), as some of the models in Table 1 seem to suggest, then the magnetization of this layer would have to be either 12 times, or 4 times the magnetizations calculated using the 6-km thick layer, except for Deep Tow data where the multiplying factor is not inversely related to thickness. This would put the necessary magnetizations into the region of 15 A/m for a layer 2A source, or 5 A/m for the layer 2 source. The direct measurements of layer 2A rocks seem to prohibit average magnetizations similar to dredged rocks. Many observations have shown that these dredged rock samples have high magnetizations because of their young age, the magnetization decaying away with a time constant of about 5 million years. Therefore, the only viable model seems to be one in which the whole of the oceanic crust is responsible for the production of the magnetic anomalies.

Other observations seem to support the idea of a thick source region for marine magnetic anomalies. Many different models of skewness call for sloping boundaries between regions of opposite polarity, the sloping boundary being the shape of a Curie isotherm in the cooling magma chamber. Sloping boundaries of the right magnitude are much more difficult to produce in the sheeted dike complex, and the boundary in the lava layer slopes in the opposite direction, and so cannot cause the observed anomalous skewness.

TABLE 4
Average Magnetization of the Oceanic Crust
(From Hayling and Harrison, 1986)

Thickness km	Material	NRM A/m	Induced Magnetization A/m in 40 uT
0.5	Pillows	3.61	0.286
1.0	Dikes	0.31	0.304
4.0	Gabbro	0.60	0.285
0.5	Serpentinites	5.09	0.686
Average magnetization in a 6-km-thick layer		1.18	0.322

Many different observations of mixed polarity have been made in rocks recovered from DSDP holes drilled into the oceanic crust, these results being limited to lava layer 2A. Reversals in vertical section tend to cause the effect of the magnetizations to be cancelled out when the field is measured at the ocean surface, rendering this layer relatively less magnetic than the magnetization of recovered rocks would suggest. This is another reason for emphasizing the need for a thick magnetized layer.

Acknowledgments

This research was supported by the National Aeronautics and Space Administration NAG-5-414. I have benefitted from discussions with Kjell Hayling and Huang Qilin. Contribution from the University of Miami, Rosentiel School of Marine and Atmospheric Science.

References

- Allredge, L. R., and F. Keller, Jr. 1949. Preliminary report on magnetic anomalies between Adak and Kwajalein, Marshall Islands. *Trans. Am. Geophys. Union* 30:494-500.
- Blakely, R. J. 1983. Statistical averaging of marine magnetic anomalies and the aging of the oceanic crust. *J. Geophys. Res.* 88:2289-2296.
- Bleil, U., and N. Petersen. 1983. Variations in magnetization intensity and low-temperature titanomagnetite oxidation of ocean floor basalts. *Nature* 301:384-388.
- Bonatti, E., and J. Honnorez. 1976. Sections of the earth's crust in the equatorial Atlantic. *J. Geophys. Res.* 81:4104-4116.
- Bullwinkel, P. 1987. Caustic aided parameter estimation and application to geophysical travel time inversion. Ph.D. dissertation, University of Miami (in prep.)
- Cande, S. C., and D. V. Kent. 1976. Constraints imposed by the shape of marine magnetic anomalies on the magnetic source. *J. Geophys. Res.* 81: 4157-4162.
- Chapman, S., and J. Bartels. 1940. *Geomagnetism*. Oxford Univ. Press. 2 vols., 1049 pp.
- Girdler, R. W., and G. Peter. 1960. An example of the importance of natural remanent magnetization in the interpretation of magnetic anomalies. *Geophys. Prosp.* 8:474-483.
- Harrison, C. G. A. 1976. Magnetization of the oceanic crust. *Geophys. J. Roy. Astr. Soc.* 47:257-284.
- Harrison, C. G. A. 1987a. The crustal field. In *Geomagnetism*, edited by J. A. Jacobs (in press).
- Harrison, C. G. A. 1987b. Marine magnetic anomalies - what causes the stripes? *Ann. Rev. Earth Planet.*

- Sci.* (in press).
- Harrison, C. G. A., H. M. Carle, and K. L. Hayling. 1986. Interpretation of satellite elevation magnetic anomalies. *J. Geophys. Res.* 91:3633-3650.
- Hayling, K. L., and C. G. A. Harrison. 1986. Magnetization modelling in the North and equatorial Atlantic Ocean using MAGSAT data. *J. Geophys. Res.* 91:12,423-12,443.
- Heezen, B. C., M. Ewing, and E. T. Miller. 1953. Trans-Atlantic profile of total magnetic intensity and topography, Dakar to Barbados. *Deep-Sea Res.* 1:25-33.
- Kidd, R. G. W. 1977. The nature and shape of the sources of marine magnetic anomalies. *Earth Planet. Sci. Letts.* 33:310-320.
- Klitgord, K. D., S. P. Huestis, J. D. Mudie, and R. L. Parker. 1975. An analysis of nearbottom magnetic anomalies: sea-floor spreading and the magnetized layer. *Geophys. J. Roy. Astr. Soc.* 43:387-424.
- Langel, R. A., and R. H. Estes. 1982. A geomagnetic field spectrum. *Geophys. Res. Letts.* 9:250-253.
- Levi, S., S. K. Banerjee, S. Beske-Diehl, and B. Moskowitz. 1978. Limitations of ophiolite complexes as models for the magnetic layer of the oceanic lithosphere. *Geophys. Res. Letts.* 5:473-476.
- Mason, R. G. 1958. A magnetic survey off the west coast of the United States between latitudes 32° and 36°N, longitudes 121° and 128°W. *Geophys. J. Roy. Astr. Soc.* 1:320-329.
- Mason, R. G., and A. D. Raff. 1961. Magnetic survey off the west coast of North America, 32°N latitude to 42°N latitude. *Bull. Geol. Soc. Am.* 72:1259-1266.
- Menard, H. W., and V. Vacquier. 1958. Magnetic survey of part of the deep sea floor off the coast of California. *Res. Rev.* (June):1-5.
- Morley, L. W. 1981. An explanation of magnetic banding in ocean basins. In *The Sea, Ideas and Observations on the Progress in the Study of the Seas*, Vol. 7, edited by C. Emiliani, pp. 1717-1719. Wiley-Interscience.
- Morley, L. W. 1986. Early work leading to the explanation of the banded geomagnetic imprinting of the ocean floor. *Eos Trans. AGU* 67:665-666.
- Parker, R. L., and S. P. Huestis. 1974. The inversion of magnetic anomalies in the presence of topography. *J. Geophys. Res.* 79:1587-1593.
- Raff, A. D., and R. G. Mason. 1961. Magnetic survey off the west coast of North America 40°N latitude to 52°N latitude. *Bull. Geol. Soc. Am.* 72:1267-1270.
- Raitt, R. W., G. G. Shor, Jr., T. J. G. Francis, and G. B. Morris. 1969. Anisotropy of the Pacific upper mantle. *J. Geophys. Res.* 74:3095-3109.
- Raymond, C. A., and J. L. LaBrecque. 1987. Magnetization of the oceanic crust. (in press)
- Runcorn, S. K. 1975. An ancient lunar magnetic dipole field. *Nature* 253:701-703.
- Schouten, H., and C. R. Denham. 1979. Modeling the oceanic source layer. In *Deep Drilling Results in the Atlantic Ocean: Ocean Crust*, edited by M. Talwani, C. G. A. Harrison, and D. E. Hayes, pp. 151-159. Maurice Ewing Series, vol. 2. American Geophysical Union.
- Schouten, H., and K. McCamy. 1972. Filtering marine magnetic anomalies. *J. Geophys. Res.* 77:7089-7099.
- Spudich, P., and J. Orcutt. 1980. Petrology and porosity of an oceanic crustal site: results from wave form modeling of seismic refraction data. *J. Geophys. Res.* 85:1409-1433.
- Talwani, M., C. C. Windisch, and M. G. Langseth, Jr. 1971. Reykjanes ridge crest: a detailed geophysical study. *J. Geophys. Res.* 76:473-517.
- Vacquier, V. 1965. Transcurrent faulting in the ocean floor. *Phil. Trans. Roy. Soc.* A258:77-82.
- Vacquier, V., and J. Affleck. 1941. A computation of the average depth to the bottom of the earth's magnetic crust, based on a statistical study of local magnetic anomalies. *Trans. Am. Geophys. Union* 22:446-450.
- Vacquier, V., N. C. Steenland, R. G. Henderson, and I. Zietz. 1951. Interpretation of aeromagnetic maps. *Geol. Soc. Am. Memoir* 47:151 pp.
- Vine, F. J., and D. H. Matthews. 1963. Magnetic anomalies over oceanic ridges. *Nature* 199:947-949.
- Vine, F. J., and J. T. Wilson. 1965. Magnetic anomalies over a young oceanic ridge off Vancouver Island. *Science* 150:485-489.

PRINCIPLES OF OPERATION AND APPLICATIONS OF RF-DRIVEN SQUID MAGNETOMETERS IN PALEOMAGNETISM AND ROCK MAGNETISM

Michael D. Fuller

*Department of Geological Sciences
University of California
Santa Barbara, CA 93106*

Introduction

It is a great pleasure to be able to contribute to this meeting for Russ Raitt and Vic Vacquier. I first met them when I came to this country in 1961. Vic had been kind enough to offer me a post-doctoral and I joined Chris Harrison, who was already working on deep-sea sediments. It is a measure of the extent of the hospitality of the Raitts that on the flight over from London, in fact as we were taking off from Heathrow, I was invited to a party at their home by the person sitting next to me. The party was to take place that evening. On arriving at San Diego some hours later I remember being met by Chris, Martha and several friends and meeting the Raitts at their lovely home overlooking the Pacific. After that things become increasingly vague until I remember waking up in a spare room the next morning — apparently the events of that long day had eventually proved too much for me and a curtain is best drawn on the remainder of those proceedings.

I spent a very happy year at Scripps and I learned a lot of geophysics. Unfortunately, I fear that I did not leave a record of very notable research during my brief stay. Indeed, the most lasting memory of that stay seems to have been over an incident during field-work in Mexico, which caused Vic some problems. Apparently, hiring burros is not something one should do lightly, if one wishes to be reimbursed by the University of California.

I then went on to Gulf Research Laboratory at Harmarville, just outside Pittsburgh, where I learned a lot more about a certain Vic Vacquier — a legendary figure there for his work on flux-gate magnetometer and aeromagnetic analysis. Although it is less well known, he also built a spinner magnetometer there. I have often wondered what might have happened had some of those rocks around Pittsburgh been a bit more conducive to paleomagnetism.

Meanwhile, I kept meeting Chris Harrison — either with Martha, or complaining that he was not with her — so that I kept in touch with Russ even though I cannot claim to be anything of a seismologist. Curiously, in a sense our paths had crossed before. I am of the vintage that in England spent two years of National Service between school and university. My two years were spent before the mast, in the Fleet Air Arm — the British Navy Air Force. My principal training was in airborne anti-submarine warfare, which involved dropping patterns of hydrophones to locate and track submarines. At the time I did not know that Russ Raitt had been involved in their optimization. Moreover, when we cooperated with the larger aircraft of Coastal Command, they were using the flux-gate detectors derived from Vic Vacquier's work.

It has been a great honor to have met Vic Vacquier and Russ Raitt, and I am very happy to be a part of this meeting. In talking with Chris about a topic to be discussed, I suggested that since Vic had played such a major role in the instrumentation of geomagnetism, it might be of some interest to talk about the SQUIDS which have come to dominate paleomagnetism recently. Moreover, since the SQUID magnetometers share so many of the detection principles of the flux-gates, the discussion might be particularly appropriate.

SQUID Magnetometers

My connection with the SQUID (=Superconducting QUantum Interference Devices) magnetometers started when a fellow called Bill Goree came into my office in Pittsburgh about 1968 and asked whether we would be interested in an instrument that had a magnetic moment sensitivity of $10 E^{-10}$ Gauss per cubic centimeter (10^{-13} amperes per square meter). I remember thinking that even allowing for an order of magnitude or two of optimism, born of what one may term the inventor's proud-father effect, this would be mighty exciting. He also pointed out that the sensor would detect the magnetic-flux density or B-field of the sample, and as long as the sample remained within the instrument the field measure would also remain. At that time, that seemed very strange since, as every schoolboy knows, it is the time-rate of change of B that one usually detects. However, it immediately suggested a number of applications not possible with instruments operating in the more familiar manner.

After I showed understandable interest, he asked how I would use such a sensor. It may well be that he should have asked what is the most convenient and inexpensive way to make use of such a sensor, but he did not, so I described how I would use such a device. Out of this came the basic design for the horizontal magnetometer with three orthogonal pick-up coils, each coupled to the SQUID detectors. This design eventually gave way to vertical systems for which the Dewar designs are easier, but recently the horizontal systems have risen again with remarkable hold times of up to a year or two. In addition, other instruments such as high-field susceptometers, small systems with 3-mm pick-up coils and gradiometers, have been developed. These instruments have the advantages of high sensitivity, fast response times and a static measurement, so that they are (if we are still allowed to say such things) an answer to a maiden's prayer, or at least a paleomagnetist's dream.

Sensor Principles

I thought that it might be worth expanding a little on why the SQUID magnetometers have the characteristics which endear them so much to paleomagnetists. SQUIDS make the observation of the quantized states of the superconducting ring possible. The currents circulating in the ring depend upon the history of B-fields that the ring has seen. Thus their relevance for us arises because they make these superconducting rings useful as magnetometers.

The name arises from the use of superconducting rings with pairs of weak links which have current field dependence with the same form as double-slit Fraunhofer diffraction — it is indeed an interference device. However, the sensors used in the early magnetometers were superconducting rings with a single weak link, which are easier to understand and so I shall describe them.

The response of a superconducting ring to a changing B-field can be interpreted in terms of a quantized Faraday induction law (Silver and Zimmerman, 1967). As the B-field increases, the DC persistent current in the ring increases in the sense to oppose the increase in B (Figure 1). In this, the superconductor acts as a perfect diamagnet and the flux lines do not penetrate the material of the ring. However, when the current reaches a critical value the ring goes normal. At this point, the flux lines can penetrate the material of the ring and a flux quantum will traverse the material of the ring. One can hardly help noticing that this is indeed a flux-gate. Indeed, it was described as a flux valve by Silver and Zimmerman (1967). The ring therefore responds in two different ways to the increase in B: (1) an increase of the supercurrent; (2) a flux transit. We therefore have a magnetic sensor, if we can determine the state of the ring. Since the flux change to bring about the normal state of the ring is very small, we also have a high-sensitivity sensor. The weak link here performs the critical step of providing a small cross-section through which all of the current must flow, so that the ring goes normal in a repeatable manner and for a small change in B-field. When it becomes superconducting again there will be a different number of flux lines inside the ring and the appropriate number of Cooper pairs within the ring. If the field continues to increase, the current will increase accordingly.

We now need some method of detecting the state of the SQUID. There are a variety of possibilities. One could simply wrap a secondary pick-up coil around the device and detect the EMF induced in it. To count the pulses associated with the flux transit would not be difficult, and this is fine for detection of fields which generate many flux transits. However, to increase sensitivity we wish to measure the circulating current and resolve it to a part in a thousand, or in ten thousand, between flux transits.

The usual method is to borrow the detection technique of the flux-gate. The SQUID is excited with a radio frequency (RF) drive voltage such that the device is taken in and out of its superconducting state twice in each half cycle, so that there are two flux transits in each half cycle (Figure 2). The figure

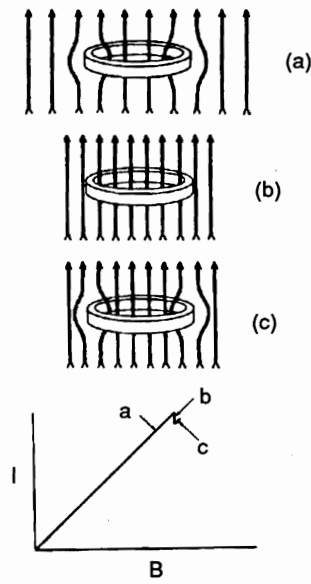

Figure 1. The response of a superconducting ring to an increasing B-field.

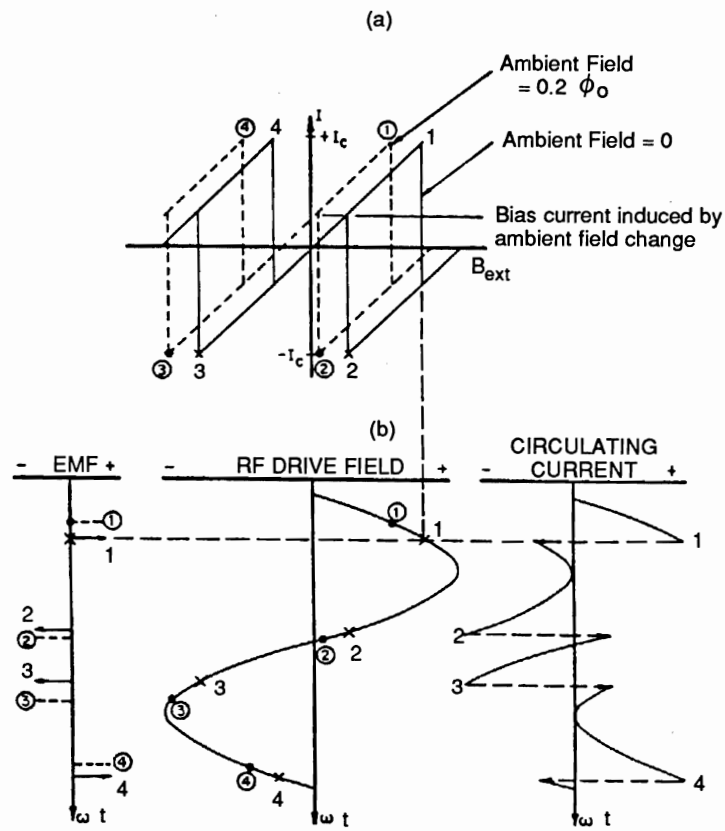

Figure 2. The current field relationship in an RF-driven SQUID and the detection of flux changes.

illustrates the current field relationship and, again borrowing from the flux-gate analogy, we compare the case when the ambient field is zero with that when it is non-zero. At 1 a flux transit takes place and so an EMF is picked up in the secondary. At 2 and 3 flux transits of the opposite sense from that at 1 take place. Finally at 4 a positive-going flux transit takes place. It can be shown that the output of such a device in the presence of B-field varies with the field as follows:

$$V (out) \propto \cos 2 \pi \left[\phi / \phi_0 \right]$$

where ϕ is the applied flux and ϕ_0 is the flux quantum $h/2e$, with h being Planck's constant and e the charge of the electron, giving numerical values of 2.07×10^{-15} weber or 2.07×10^{-7} maxwells. The output of the RF detection system therefore has a non-linear dependence upon field. A negative feedback system is therefore generally used to lock the instrument at a single operating point and to provide a DC voltage as a linear measure of the field.

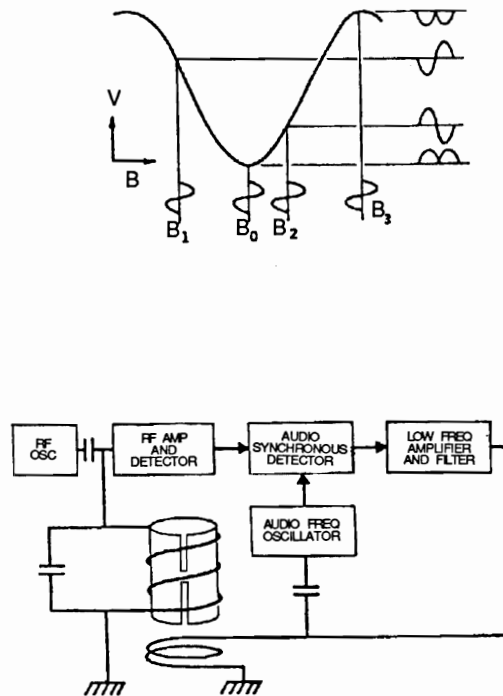

Figure 3. The operation of an audiofrequency modulated SQUID: (a) schematic of modulation and output of SQUID; (b) electronics. After Nisenoff (1970).

The feedback loop is achieved by modulating the ambient field with a small audiofrequency field (Nisenoff, 1970). The trace in Figure 3a shows the output of the SQUID as a function of the ambient field. Let us choose a point B(1), as the external field point, about which the audiofrequency field modulation is carried out. With the increasing field the output of the SQUID will decrease. At other points the field will increase, so that if this signal is detected and amplified by a synchronous detector tuned to the modulation frequency, it can be used to sense the position of the SQUID in its periodic field dependence. For example, the output will be positive at B(2), negative at B(1), and zero at B(0) and B(3). Conversely, if we detect at twice the modulation frequency, the maximum outputs will be at B(0) and B(3). Such signals can be made the basis of a digital magnetometer (Nisenoff, 1970), but in our application we are interested in the generation of a signal that can be used in a feedback loop.

To complete the feedback loop a DC field is applied to the SQUID such that when the SQUID experiences a changing applied field, the feedback to the SQUID responds so as to hold it at its operating point (Figure 3b). In this way the very non-linear field dependence is eliminated and the output is then a DC signal which is proportional to the B-field change.

We still need to couple the SQUID to the sample to be measured for paleomagnetic purposes. For this pick-up coils are used to generate a current proportional to the B-field change brought about by the insertion of the sample. Figure 4 shows a typical arrangement. The current induced in the pick-up coils is

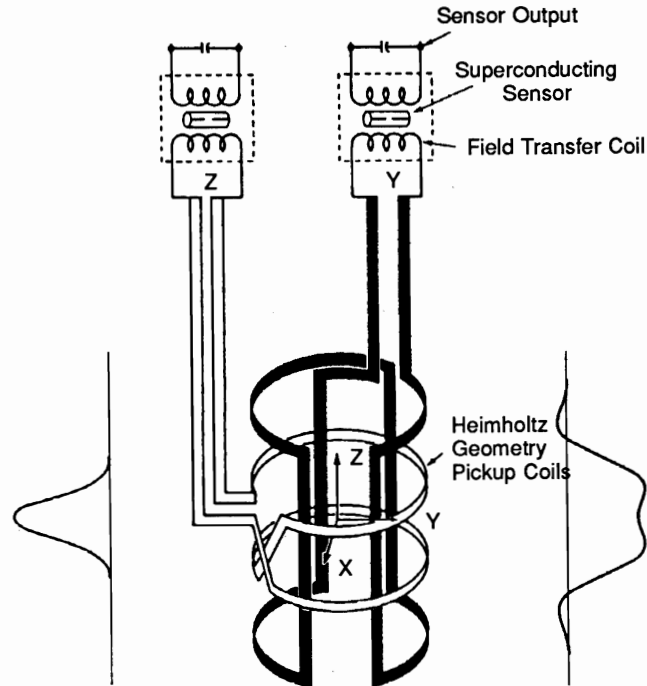

Figure 4. The coupling of the SQUID detector to the sample via superconducting coils in rock magnetometers.

a DC persistent current which is fed to the SQUID to be detected. Note that since this current is indeed a DC persistent current, it does persist until the flux linking the pick-up coil changes; i.e., until the magnetization of the sample changes, or the sample is moved. This is a key aspect of the device which permits many of the applications. Indeed, it was this feature that attracted me to the instruments, almost as much as the sensitivity.

Magnetometers

In addition to the magnetometers described already — that is, the vertical and horizontal remanent magnetometers — other important instruments have been made by a number of groups.

- (1) X-systems permit high field observations, as a function of temperature from liquid helium to room temperature.
- (2) Gradiometers: because of the rapid fall-off of field of a dipole, one can build a gradiometer which in the near-field mode essentially measures field. The old astatic magnetometers, such as the one Chris and I had some fun operating up on the hill above Scripps Institution, are really gradiometers which are operating in the near-field mode. A number of groups now have such instruments.

Applications

RF SQUID magnetometers are used by paleomagnetists to make high-sensitivity measurements rapidly. In conjunction with the availability of inexpensive microcomputers, the new magnetometers have made possible more sophisticated data analysis for AF and thermal demagnetization. This promises to rid paleomagnetism of some of the subjectivity that has always been a source of discomfort.

Many other applications are possible. One grew out of my time at Scripps. Clearly one can regard the passage of a long core through the instrument as a convolution of the sample core with the response of the magnetometer, and I remember talking with Bob Parker about this. To obtain better resolution, one simply carries out the deconvolution. This led to determinations of the remanent magnetism of long cores with resolution of a few cms.

We were also able to take advantage of the DC persistent current to carry out thermal demagnetization with measurements at high temperature. This caused some excitement when flame furnaces and laser heaters got away from us. To avoid these difficulties we have recently been using a compromise system, in which the sample is heated outside of the magnetometer and because of the rapid measurement time, it can be measured without any significant loss of temperature.

We have also been interested in magnetization changes brought about by stress effects. Again, we are able to study these effects by stressing rocks within the system. This too can get exciting every so often.

Future Developments

I think that the next development will be the increasing use of gradiometers. Remember that this will make possible the simultaneous measurements of three components, the total determination of the remanent moment, or if one applies a field the induced moment of a sample, simply by bringing it up close to the pick-up coils. This will make all the experiments involving ancillary equipment much easier because the devices will not have to be constructed inside the magnetometer. It will mean that we can measure long cores with much better initial resolution. We shall be able to make routine Curie point runs to identify the magnetic minerals present in a sample that we have used for paleomagnetic purposes. Measurements at high temperature will be much easier than in the present instruments, so that we will have a true continuous thermal demagnetization and possibly intensity-determination methods. All in all, it could prove an exciting time for instrumentation in rock and paleomagnetism. Even though we will not be seeing the fundamental breakthroughs that Vic was associated with, when for the first time one was able to measure the geomagnetic field with modern electronic devices, there should still be plenty to keep us busy. Meanwhile, a challenge for the instrument builders will be taking advantage of the recent increases in the temperatures for superconductivity.

In closing I would like to thank Vic Vacquier for making it possible for me to come to this country and to be a part of all the exciting things that have gone on over here in geophysics in the past 25 years.

References

- Nisenoff, M. 1970. A superconducting magnetometer with sensitivity approaching 10^{-10} Gauss. *Rev. Phys. Appl.* 5:21-32.
- Silver, A. H., and J. E. Zimmerman. 1967. Quantum states and transitions in weakly connected superconducting rings. *Phys. Rev.* 157:317-340.

HEAT FLOW OFF SUMATRA

Lawrence A. Lawver

*Institute for Geophysics
University of Texas at Austin
8701 N. Mopac Blvd.
Austin, TX 78759*

and

Patrick T. Taylor

*Goddard Space Flight Center/NASA
Geophysics Branch: Code 622
Greenbelt, MD 20771*

Abstract

Heat flow has been measured in the Sunda Trench west of Sumatra on two separate occasions by researchers from Scripps Institution of Oceanography. On the first occasion, a regional survey in 1964 recorded 61 values, while in 1977 a detailed survey obtained 12 values south and west of Nias Island. The first survey was published (Vacquier and Taylor, 1966) and interpreted (Taylor, 1965; 1966) prior to the general plate-tectonics revolution while the second survey was only reported in abstract form (Lawver and Vacquier, 1977). The 1977 survey data were collected either in the Sunda Trench or in small basins on the landward side. The trench values reveal slightly above normal values while the landward heat-flow measurements are well below average. The results from both the 1964 and 1977 surveys agree and support the veracity of the observed anomaly pattern. In this report we have combined and discussed both data sets and reinterpreted the heat-flow pattern in terms of plate tectonics.

A heat-flow high ($>60 \text{ mW/m}^2$) parallels the Sunda Trench, bordered on either side by low values, and may indicate the localized strain. From seismicity studies there are indications of significant intra-plate stress build-up in the region between the Ninetyeast Ridge and the Sunda Trench. We interpret the observed pre-trench heat-flow high to be produced by hydrothermal circulation through the sediment and upper crust.

Introduction

The International Indian Ocean Expedition (IIOE) was a multi-year, multi-nation, multi-institution study of the then unknown Indian Ocean. As part of this program, Robert L. Fisher of Scripps Institution of Oceanography organized three round-the-world expeditions (Monsoon, Lusiad, and Dodo). During the latter part of Dodo Expedition, Victor Vacquier and Richard Von Herzen took heat-flow measurements across the Central Indian Ocean Ridge (Von Herzen and Vacquier, 1966). On the next leg of Dodo Expedition, Vacquier, Taylor and Sclater took heat-flow measurements in the region of the outer trench bathymetric high south of the Sunda Trench in the eastern section of the Indian Ocean (Figure 1). The objective of the latter cruise was to investigate the possibility of a pre-trench heat-flow high. The suggestion of such a high had occurred to Vacquier while looking at an unpublished map of heat-flow values from the North Pacific east of Japan. The map had been compiled by Teruhiko Watanabe and was

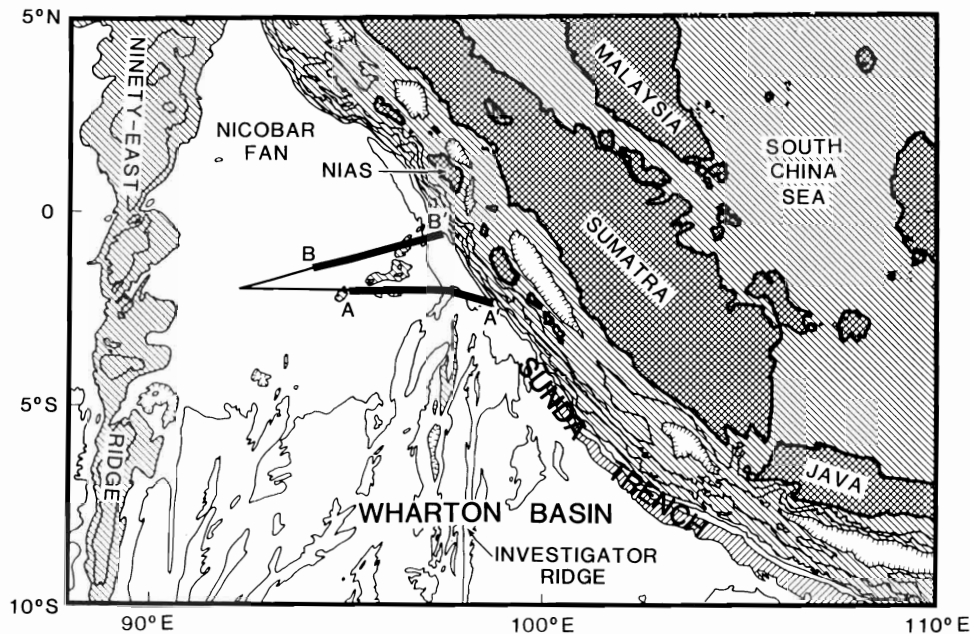

Figure 1. Bathymetric chart of the northern Wharton Basin. Thousand-meter contour interval based on the GEBCO 5.09 chart (Fisher, 1982). Depths less than 3000 meters shown with northwest-southeast diagonal lines except for basins on the Sumatra continental shelf which are shown hatched. Depths greater than 6000 meters are shown with northeast-southwest diagonal lines. Land areas are shown cross-hatched. The two seismic lines shown in Figure 5 are indicated with heavy lines A-A' and B-B'.

later included in Watanabe *et al.* (their Figure 1a, 1977). Vacquier and Taylor (1966) presented the findings from their cruise and contoured their data to show a distinct pre-trench heat-flow high about 200 km seaward of the Sunda Trench. In addition they recognized east-west trends in the magnetic anomalies which do not follow the curve of the Sunda Trench. Taylor (1966) discussed the possible causes of the heat-flow high and concluded that the most likely cause was geothermal convection currents. Based on the width of the heat-flow anomaly, Taylor (1966) concluded that the anomaly was caused by a 200-km deep convection cell situated in the upper mantle.

Shortly after 1966 the plate-tectonic revolution occurred, leading to an improved understanding of the forces operating at subduction zones. Sclater and Fisher (1974) identified the magnetic anomalies in the Wharton Basin, confirming Vacquier and Taylor's (1966) suggestion of east-west trending anomalies. Liu *et al.* (1983) later reinterpreted these anomalies by assuming a number of fossil spreading centers (Figure 2), where spreading stopped about 45 to 50 million years before present (m.y.b.p.). The earlier Sclater and Fisher (1974) model indicated spreading that stopped only upon subduction of the spreading centers which occurred as late as 30 m.y.b.p. In the model of Sclater and Fisher, the Ninetyeast Fracture Zone represents a major offset of over 1500 km between spreading centers. They assumed a fossil spreading center that was still active at anomaly 13 time (although extension of the Sclater and Fisher anomalies to the trench from their Figure 7A indicates spreading younger than anomaly 12 time [33 Ma]). The model of Liu *et al.* (1983) reduces the greatest offset between fracture zones to 600 km.

Following the observations of Vacquier and Taylor (1966), Lawver and Vacquier (1977) made additional heat-flow measurements on the Sunda Trench wall, while Carvalho *et al.* (1980) used bottom-hole temperatures from oil wells and measured or estimated thermal conductivities to calculate heat-flow values in the central Sumatra region. In addition, Aadland and Phoa (1981) estimated geothermal gradients for a number of oil wells in Sumatra and these can provide approximate heat-flow values if the same thermal conductivities that Carvalho *et al.* (1980) determined can be applied to these geothermal gradients. Since the new marine data shown in Table 1 have not previously been published and the tectonic evolution of the Wharton Basin is now better understood than when Vacquier and Taylor (1966) and Taylor (1966) were published, we felt that these data should be combined and the interpretation updated.

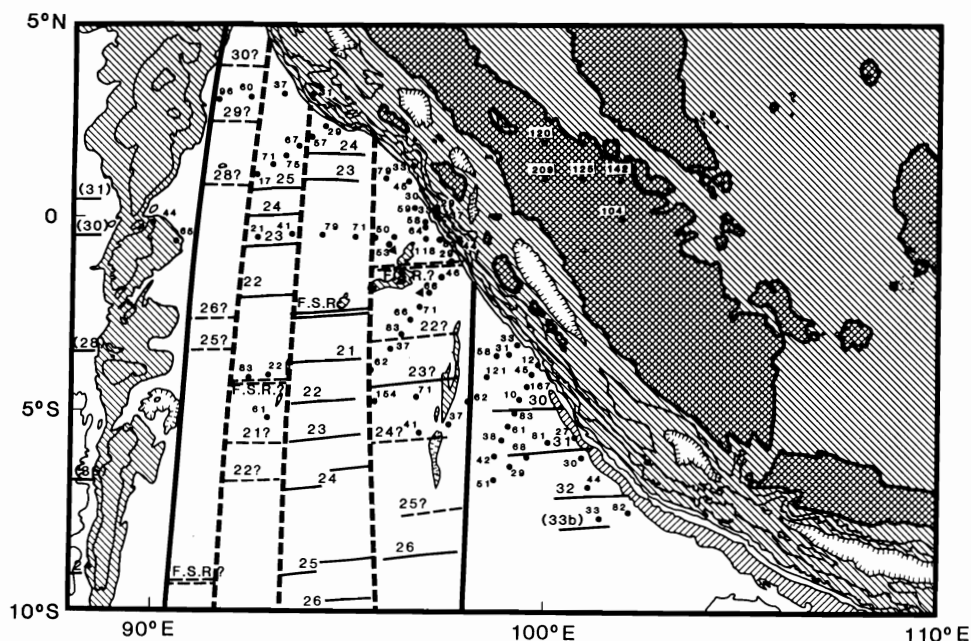

Figure 2. Tectonic reinterpretation of Sclater and Fisher (1974) by Liu *et al.* (1983) shown on the GEBCO 5.09 bathymetry. Larger numbers are the magnetic anomaly identification while the smaller numbers represent heat-flow values in milliwatts per meter². Triangles are the approximate location of the pre-trench bathymetric high deduced from the profiles shown in Figure 5.

TABLE 1

INDOPAC-12 HEAT FLOW STATIONS OFF SUMATRA								Environment
STATION NUMBER	LATITUDE	LONGITUDE	DEPTH (meters)	delta T ₁ (°C/m)	delta T ₂ (°C/m)	THERMAL CONDUCT. (W/K·m)	HEAT FLOW (mW/m ²)	
HF-3	00°59.9'N	96°01.6'E	4836	0.11	0.11	0.72	79	Oceanic
HF-4	00°13.71'S	97°00.61'E	5247	(0.09)	0.082	0.79	65	Trench
HF-5	00°14.0'N	97°19.6'E	3107	0.047	0.042	0.70	33	Trench Wall
HF-7	00°08.2'N	97°13.8'E	3340	0.052	0.058	0.71	37	Trench Wall
HF-8	00°07.99'N	97°14.91'E	3312	0.052	0.066	0.71	37	Trench Wall
HF-9	00°03.42'N	97°16.34'E	3014	0.052	0.050	0.72	37	Trench Wall
HF-10	00°07.94'S	97°01.56'E	5289	0.074	0.066	0.89	59	Trench
HF-11	00°54.83'N	96°35.96'E	5235	(0.024)	(0.047)	0.85	46*	Trench
HF-12	00°12.25'N	96°14.54'E	5167	0.079	0.078	0.76	59	Trench
HF-13	00°03.05'S	97°24.1'E	2965	0.052	0.049	0.72	37	Trench Wall
HF-14	00°41.0'N	96°56.5'E	3870	0.052	0.039	0.72	37	Trench Wall
HF-15	01°16.69'N	96°42.96'E	3051	0.048	0.043	0.70	33	Trench Wall

*indicates measurement made with partial penetration and >30° tilt.

Heat-flow Measurements

In 1964, Scripps Institution of Oceanography conducted a regional heat-flow survey off Sumatra as part of the International Indian Ocean Expedition (Vacquier and Taylor, 1966). Of the 61 thermal gradient measurements made during their cruise (Dodo Leg 8; Figure 3), 57 were made using a Von Herzen short temperature-gradient probe (Von Herzen and Uyeda, 1963). This instrument was similar to the needle-probe thermal gradiometer of Bullard (1954). Four heat-flow measurements were made using the Ewing-type gradiometer where the thermistor probes are attached to a piston corer (Lister, 1962). John Sclater

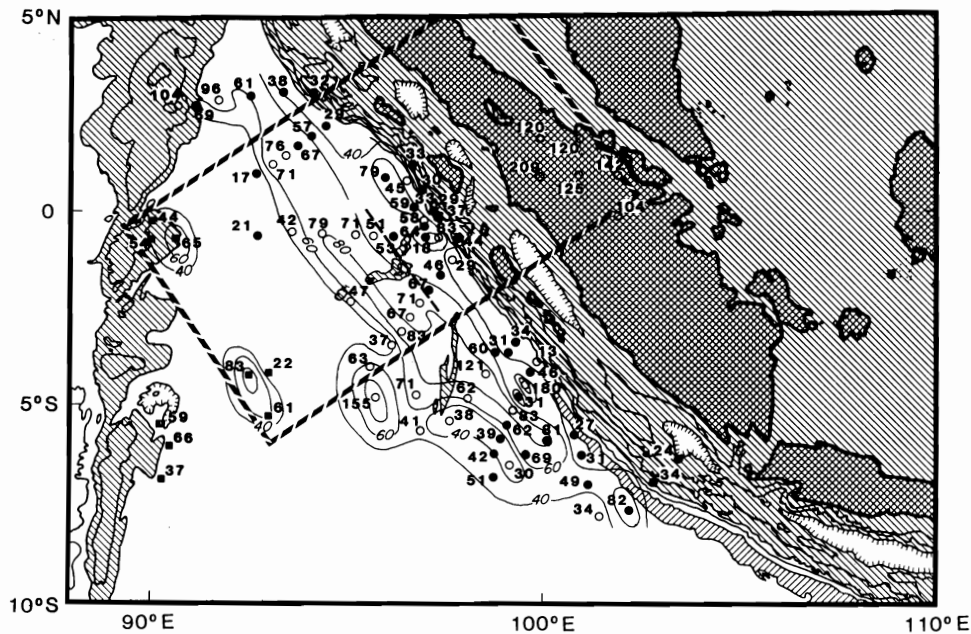

Figure 3. Heat-flow values in milliwatts per meter² shown contoured. There appears to be an almost continuous heat-flow high that extends from north of Nias near the northern end of the Ninetyeast Ridge to west of the southern tip of Sumatra. Box indicates area of heat-flow values shown on transect in Figure 6.

was a member of the shipboard party and provided and operated the Cambridge University Ewing-type probe. This particular model consisted of three outrigger thermistors attached to a piston corer. Seventeen gravity cores were taken for thermal conductivity measurements in addition to the four piston cores used for the Ewing-type probe heat-flow values. The major problem with the original heat-flow survey using the Von Herzen probe was the critical importance of knowing the depth of penetration of the probe. The Von Herzen probe had only two thermistor positions separated by 1.7 meters. The pressure case housing the electronics had a small Phleger-type corer attached to it which indicated full penetration. In the region off Sumatra the sediment was unusually hard and partial penetrations were common.

The major sediment types in this region are turbidites (Bowles *et al.*, 1978) or else terrigenous sediments low in carbonates. Near the Sunda Trench the sediments are rich in volcanoclastic material (Udintsev, 1975). When it became apparent that the probe was not fully penetrating, three additional miniature core barrels were taped to the probe at 80, 110, and 150 cm from its tip end to determine depth of penetration. In addition, depth of penetration could be estimated by measuring the height of the sediment smear on the probe. It is possible, however, that some of the very high heat-flow values from Dodo Expedition may be too high because the probe actually penetrated further than was estimated. Consequently, the heat-flow values shown in Figure 3 as open circles did not have full penetration and should therefore be considered less reliable than ones shown as filled circles. No relationship, however, was found between the amount of penetration and the measured heat flow (Taylor, 1965). The instrument did have a crude tilt indicator which determined that virtually all the measurements were within a few degrees of vertical. One qualitative test of measurement error concerns how closely the measured heat-flow values agree with the next nearest measurement and the extent to which these data are contoured. With the exception of certain of the abnormally high heat-flow values, which will be discussed later, these data can be contoured and the more recent measurements agree with the older values in the same region.

The 12 measurements (Lawver and Vacquier, 1977) taken with a modified Bullard probe (Corry *et al.*, 1968) are listed in Table 1 and shown in Figure 4. All had at least two thermistors fully buried in the sediments while 10 of the 12 had three thermistors penetrate so that two independent one-meter thermal gradients could be determined. Most of the deeper thermal gradients were slightly less than the upper ones, as would be expected given increasing thermal conductivity with depth. The seven measurements taken in sediment ponds on the inner-trench wall (see Figure 9 of Kieckhefer *et al.*, 1980) are remarkably consistent. They vary from 33 to 37 mW/m². The four values taken on the small shelf at 97° 15'E agree within the accuracy of the instrumentation for the upper meter of the thermal gradient. Both of the values

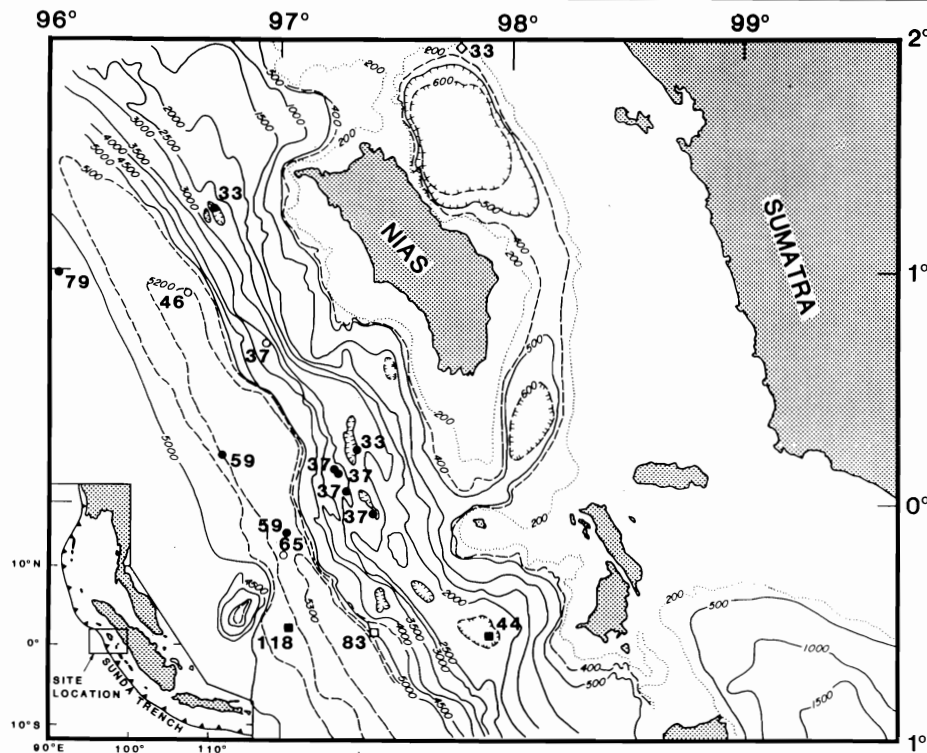

Figure 4. Detailed map of the bathymetry and heat flow off Nias. The bathymetry is from Moore and Curray (1980). Circles indicate heat-flow values listed in Table 1, the diamond is a calculated value using the geothermal gradient from the Indonesian Geothermal Gradient map (Aadland and Phoa, 1981), and squares are the heat-flow values from Vacquier and Taylor (1966). Filled symbols indicate relatively good values, open symbols represent poorer values.

measured in the trench, but closest to the inner trench wall, showed partial penetration of 168 cm and ~150 cm with the last one also indicating at least 30° tilt. These two values are shown in Figure 4 as open circles rather than the closed values which indicate both full penetration and a vertical (less than 15° tilt) penetration. At the stations in the trench and at one isolated site on the inner trench wall, a very tough pavement-like bottom with a lot of sandy grit was encountered. The coarse sediment found in the trench bottom is not surprising and may have been transported from the Nicobar Fan to the northwest.

For the 1964 data, 21 cores were taken and needle-probe thermal conductivity measurements were made on each of them (Vacquier and Taylor, 1966). The calculated thermal conductivity values ranged from 0.68 to 1.17 W/m²K with most falling in the 0.77 to 0.85 W/m²K range, typical of pelagic oceanic sediments. For the more recent heat-flow values the thermal conductivity values varied from 0.70 to 0.89 W/m²K. It is probable that some of the thermal conductivities encountered in the lower meter of the sediments may have ranged up to 0.95 W/m²K in order to explain the difference in measured thermal gradient between the upper and lower sections of the probe. For the 40 heat-flow values from the Vacquier and Taylor (1966) study with inferred thermal conductivity measurements some uncertainty exists, but this is true for any heat-flow measurement that did not utilize *in situ* thermal conductivity measurements. Even needle-probe thermal conductivities measured on nearby cores can be suspect. The ability to contour the heat-flow data lends it a qualitative credibility.

Discussion

The standard heat-flow-versus-age relationship (Parsons and Sclater, 1977) implies a heat flow of between 54 and 67 mW/m² for the oceanic crust off Sumatra. While many of the measurements fall into this range, there is definitely a band of heat flow exceeding 70 mW/m². Some values shown on Figure 2 may have been influenced by tectonic factors other than the simple heat-flow-versus-age relationship. The two values of 22 and 83 mW/m² located on the fossil spreading ridge at 93°E may have been influenced by

residual hydrothermal circulation at the fossil spreading center, while the value of 154 mW/m^2 at $4^\circ 41' \text{S}$, $95^\circ 45' \text{E}$ may be caused by residual hydrothermal circulation along a once-active fracture zone. Two abnormally high heat-flow values near the trench axis (118 mW/m^2 at $0^\circ 32' \text{S}$ and 180 mW/m^2 at $4^\circ 18' \text{S}$) were both taken with the Ewing-type heat-flow probe which may indicate a systematic instrumentation bias. Without those two values the general heat-flow values near the trench axis range from 29 to 83 mW/m^2 with most of the values between 31 and 59 mW/m^2 .

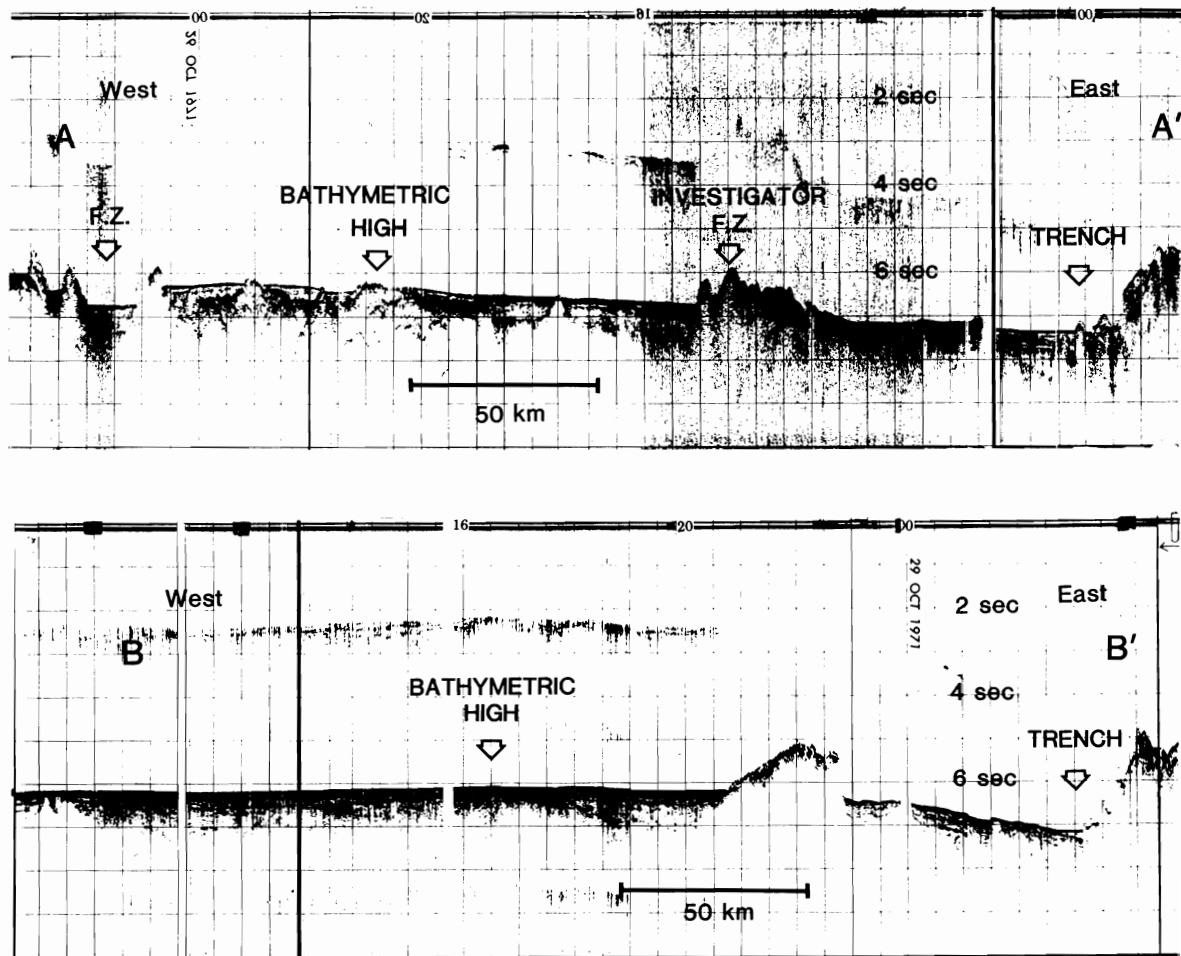

Figure 5(a). Seismic-reflection profile A-A' (location shown on Figure 1) from Bowles *et al.* (1978) shows a crossing of the Sunda Trench with the Investigator Fracture Zone on the right. A prominent fracture zone is seen at 0130 on 26 Oct 1971. The pre-trench bathymetric high seems to occur at about 2100 on 25 Oct 1971. (b). Seismic-reflection profile B-B' (location shown on Figure 1) from Bowles *et al.* (1978) shows a crossing of the Sunda Trench just north of A-A'. The pre-trench bathymetric high appears to be at approximately 1630 on 28 Oct 1978.

The pre-trench bathymetric high can be seen in a number of profiles that cross the Sunda Trench. Bowles *et al.* (1978) discuss the seismic-reflection results shown in Figure 5. These two seismic profiles run almost parallel to the fossil spreading centers as identified by Liu *et al.* (1983). The Investigator Fracture Zone occurs as a rough bathymetric feature as it enters the trench (Figure 5a). In fact, the actual trace of the fracture zone may be west of where it is shown both by Liu *et al.* (1983) and on the GEBCO chart of the region (Fisher, 1982). The next fracture zone at 0130 on 26 Oct 1971 (arrow F.Z., Figure 5a) is a prominent feature on A-A' but does not show up prominently on B-B'. The inferred fracture zone to the west is covered with sediments and does not appear on either profile, although there may be some indication of this westernmost inferred fracture zone.

A pre-trench bathymetric high is apparent on A-A' at 2100 on the profile of 25 Oct 1971 (Figure 5a) and on B-B' at 1630 on 28 Oct 1971 (Figure 5b). These two points on the seismic tracks are shown on

Figure 2 as small triangles and the trend of the bathymetric high is shown as the short dashed line on Figure 3. It is interesting to note that the alignment of the bathymetric high is parallel to the trench and does not seem to reflect the fossil spreading center or the tectonic structure shown from Liu *et al.* (1983).

Seismic-reflection surveys crossing many trenches in the western Pacific region as well as the Sunda Trench of southeast Asia reveal a broad (about 100 km) upward bowing of the crust (maximum of 500 m) immediately oceanward of the trench, called the outer arch or swell (Hayes and Ewing, 1970). According to Melosh (1978), this rise is associated with a +50 to +80 mgal free-air gravity anomaly and is probably not isostatically compensated (Watts and Talwani, 1974). Various rheological models have been developed to explain this deformation of the ocean floor by either elastic or elastic-plastic rheologies (Melosh, 1978; McAdoo and Sandwell, 1985).

With regard to the heat-flow survey conducted by Vacquier and Taylor (1966) to investigate the pre-trench heat-flow high, the heat-flow anomaly parallels the general structural and bathymetric trends west of Sumatra. While the correlation coefficients do not support a rigorous mathematical correspondence, there is nonetheless a distinct qualitative agreement. Simple age-versus-heat-flow relationships (Parsons and Sclater, 1977) suggest that the heat flow measured oceanward of the trench should range from 54 to 67 mW/m² for the whole region of the northwest Wharton Basin. To the very eastern edge of the survey area where anomaly 33 is found, the heat flow might be expected to be as low as 50 mW/m². Consequently, if the heat-flow measurements made by Vacquier and Taylor (1966) are statistically valid, then both the high and low values (>67 and < 50 mW/m²) are most likely anomalous. The bending of the oceanic lithosphere prior to subduction in the trench may affect the measured conductive heat flow.

Since the publication of Vacquier and Taylor (1966) and Lawver and Vacquier (1977), a number of papers have been written concerning the region between the Ninetyeast Ridge and Sumatra. In this sector of the ocean floor are found the largest (magnitude) intra-plate oceanic earthquakes. Weissel *et al.* (1980) and Geller *et al.* (1983) both discussed the intra-plate deformation of the Indo-Australian plate. Geller *et al.* (1983) concluded that the recorded observations suggest that the processes causing the deformation of the plate have increased the heat flux through the sediment-water interface. They inferred that the extra heat is being generated at shallow depths (less than 35 km) in the plate. The one heat-flow value that they report from this region, 83 mW/m², was briefly discussed earlier. It is at 4° 02'S, 92° 33.3'E and is located on a fossil spreading ridge that ceased spreading at anomaly 19+ time (50 Ma). This fossil spreading ridge now appears to be well covered with 500 meters of sediment so it is unlikely that the excess 20 mW/m² can be solely attributed to remnant hydrothermal circulation in the upper part of the oceanic crust. There are faults spaced every 3-5 km along their track in this region that have vertical displacements of less than 0.1 sec of two-way travel time, but the horizontal component of displacement could not be determined. Their heat-flow value (Geller *et al.*, 1983) was taken at the base of one of these reverse faults. The Bowles *et al.* (1978) seismic-reflection results do not indicate nearly as many faults cutting the surface, so it is probable that the forces producing the intra-plate deformation are not the same as those producing the pre-trench bathymetric high. However, Levchenko *et al.* (1986) conducted a seismic study between Engano Island and the outer swell and interpreted the data to indicate vertical faulting with an approximate 10-km spacing.

Deviatoric stress at the outer rise or pre-trench bathymetric high has been discussed by Hanks (1979) for general cases and more recently by Cloetingh and Wortel (1985) for the Indian plate. Hanks (1979) concluded that the "lithospheric normal-faulting earthquakes" cannot arise from tectonic stresses due to bending, and argue against the flexure origin of the outer rise locally (for the Sanriku earthquake of 3 March 1933 and the Java Trench earthquake of 19 August 1977) and perhaps globally as well, despite the separate bathymetric, gravimetric, and seismological evidence which does provide support for the flexure origin of the outer rise. Melosh (1978) developed a model for the origin of the outer rise that does not require multi-kilobar deviatoric stresses in the lithosphere. His model does include stresses developed by viscous flow of the lower part of the lithosphere as it is subducted. The elastic upper part of the lithosphere, treated generally by Melosh (1978), is subject to extensional stresses on the seaward side of the trench axis.

Wortel and Cloetingh (their Figure 10b, 1986) indicate that there should be compression normal to the trench off Sumatra but that stress may in fact cause the pronounced bathymetric high along an obliquely subducting trench. Cloetingh and Wortel (1986) calculated the principal horizontal stresses for the Indo-Australian plate. Their results indicate compression (>3 kbar) off Sumatra, parallel to the trench, but that the deviatoric stress changes to extension perpendicular to the trench off Java. They propose that this change in stress is a result of the variation in age of the subducting lithosphere but it seems more likely that it is caused by a change from normal subduction to oblique subduction. Liu *et al.* (1983) indicate that the greatest variation in age along the Sunda Trench off Sumatra is between 50 Ma west of 98°E and ~65 Ma to the east of 98°E. Although mechanical properties and thickness of the lithosphere vary with age, this

does not seem to represent a substantial variation along the trench axis. The seismic history and seismotectonics of the Sunda Arc (Newcomb and McCann, 1987) indicate only one extensional fault plane solution oceanward of the Sunda Trench and two right on the lower part of the inner trench wall just east of Sumatra. They do suggest that there is a significant variation in inter-plate seismicity between the Sumatra region and the Java region due to the difference in age of the subducted crust.

The very large intra-plate earthquakes of this sector (Fitch *et al.*, 1981; Bergman and Solomon, 1984; Newcomb and McCann, 1987) have led Wiens and co-authors (1985, 1986) to suggest a diffuse convergent plate boundary that extends in an east-west direction through this region centered around 2°N, just north of Nias Island. Hobart and Stein (1987) conclude, based on a re-analysis of the heat flow in the Wharton Basin, that the diffuse plate boundary cannot be seen in the Wharton Basin as it is clearly seen in the central Indian Ocean west of the Ninetyeast Ridge. They place the new diffuse convergent boundary north of 5°N and so not a factor in our discussion of the pre-trench heat-flow high.

Hilde and Sharman (1978) and Schweller *et al.* (1981) indicated that there should be graben formation caused by extension in the upper part of the oceanic lithosphere in our study area. The boundary faults of these grabens would be ideal conduits for hydrothermal circulation of fluids producing abnormal heat-flow values in the region of upper crustal extension. In addition, Hilde (1983) noted the relationship between the plate bending into trenches and rupture or cracking of the plate near the outer bathymetric high or outer swell. The outer rise cannot be a static feature of the convergence zone-trench boundary. Movement of the outer swell or flexure of the ocean lithosphere away from the trench axis could result from increasing gravitational forces on the descending plate (Wortel and Cloetingh, 1986). It is assumed that a variation in age of the subducting plate should have a minor effect on the location and size of the pre-trench bathymetric high.

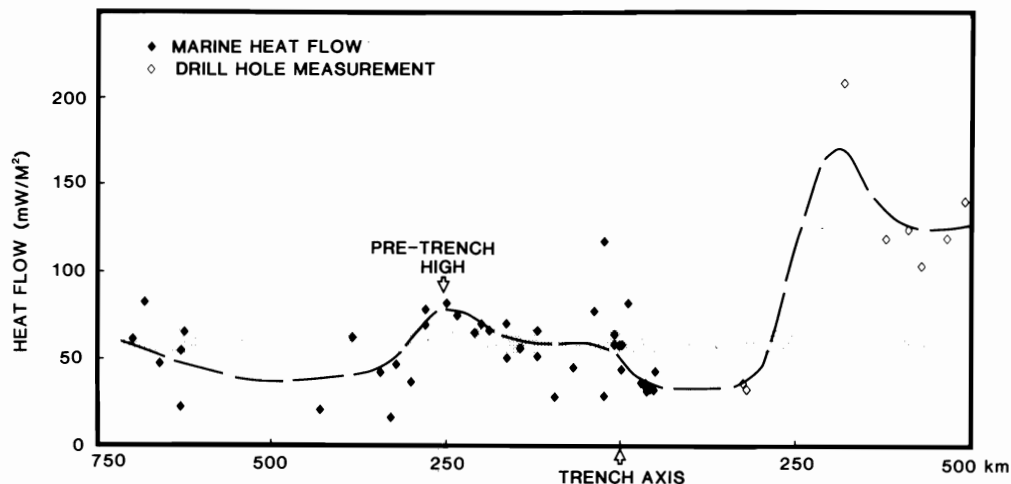

Figure 6. Heat-flow transect showing measured or estimated heat flow plotted versus distance from the trench axis. Stippled region is theoretical heat flow for this region based on the heat-flow-versus-age relationship of Parsons and Sclater (1977). Region of transect is shown on Figure 3.

Geller *et al.* (1983) analyzed the heat-flow data from the central Indian Ocean. They found non-linear thermal gradients on a number of heat-flow measurements taken in a region of deformation. They concluded that the variable heat-flow pattern observed in this region of deformation (located near the northern terminus of the Ninetyeast Ridge) is "typical of a hydrothermal convection system." They did not, however, observe low heat-flow values which would be expected with a circulating water system. They suggested that insufficient sampling was the explanation for the failure to detect these low values. The overall Sumatra data set (Vacquier and Taylor, 1966; Carvalho *et al.*, 1980; this paper) includes not only high values (>80 mW/m²) but low values (<30 mW/m²) as well. A heat-flow transect (Figure 6) across Sumatra near Nias shows the pre-trench heat-flow high, the very low values on the inter-trench wall and the scattered high values in the central Sumatra Basin.

The heat-flow pattern observed off Sumatra and its relationship to the trench and outer rise can be qualitatively interpreted as being caused by a hydrothermal system. The low heat-flow values occur both trenchward and oceanward of the axis of the higher heat flow. The proposed hydrothermal system is

centered about 50 to 100 km oceanward of the axis of the pre-trench bathymetric high. It is possibly caused by the bending and cracking of the lithosphere allowing a recharging system to develop in the upper crust. Geller *et al.* (1983) suggest that the source of this heat is shallow, less than 35 km. In this scenario the region of lower heat flow would represent regions of recharge where water returns to the upper lithosphere. An alternative explanation involves the initial upward bending of the lithosphere producing initial compression in the overlying sediment. This initial compression in the near-surface sediments causes water expulsion to occur, which initially produces heat flow higher than expected. Later extension as the lithosphere passes over the outer rise would produce confused observations, with heat flow both higher than normal and lower than normal being observed. As the initial heat is lost because of water expulsion from the sediments or from minor near-surface hydrothermal convection, the sediment is scraped off as the oceanic slab is subducted and a "cold" pile of sediment accretes to the trench wall. While it is attractive to relate the heat-flow transect shown in Figure 6 to the thermal structure of a bending lithosphere and use it to determine if the lithosphere is behaving rigidly or elastically or plastically, we feel that the number of unknowns concerning the available thermal data precludes such speculation.

Acknowledgments

We wish to thank Nancy Killough of the Institute for Geophysics for drafting the figures. We also would like to thank Vic Vacquier for his inspiration, dedication and help to get both of us through our Ph.D.'s. Much of the original work depended upon the help of many of the technicians and support staff of the Marine Physical Laboratory of Scripps Institution of Oceanography. We wish to express our appreciation to all of them for the many courtesies that they have shown us. Fred Bowles (NORDA, Bay St. Louis, MS) kindly provided us with his seismic-reflection data in this region. John Sclater reviewed the manuscript. This is contribution number 716 from the Institute for Geophysics, the University of Texas at Austin.

References

- Aadland, A. J., and R. S. K. Phoa. 1981. Geothermal gradient map of Indonesia. Indonesian Petr. Assoc., Jakarta:43 pp.
- Bergman, E. A., and S. C. Solomon. 1984. Source mechanisms of earthquakes near mid-ocean ridges from body waveform inversion, implications for the early evolution of oceanic lithosphere. *J. Geophys. Res.* 89:11415-11441.
- Bowles, F. A., W. F. Ruddiman, and W. H. Jahn. 1978. Acoustic stratigraphy, structure, and depositional history of the Nicobar Fan, eastern Indian Ocean. *Mar. Geol.* 26:269-288.
- Bullard, E. 1954. The flow of heat through the floor of the Atlantic Ocean. *Proc. Roy. Soc. London* 222(A):408-409.
- Carvalho, H., Purwoko, Siswoyo, M. Thamrin, and V. Vacquier. 1980. Terrestrial heat flow in the Tertiary basin of central Sumatra. *Tectonophysics* 69:163-188.
- Cloetingh, S., and R. Wortel. 1985. Regional stress field of the Indian plate. *Geophys. Res. Letts.* 12:77-80.
- Cloetingh, S., and R. Wortel. 1986. Stress in the Indo-Australian plate. *Tectonophysics* 132:49-67.
- Corry, C., C. Dubois, and V. Vacquier. 1968. Instrument for measuring terrestrial heat flow through the ocean floor. *J. Mar. Res.* 26:165-177.
- Fisher, R. L. 1982. 5.09: The Indian Ocean south of the equator. *General Bathymetric Chart of the Oceans* (GEBCO), Canadian Hydrogr. Service, Ottawa.
- Fitch, T. J., R. G. North, and M. W. Shields. 1981. Focal depths and moment tensor representations of shallow earthquakes associated with the great Sumba earthquake. *J. Geophys. Res.* 86:9357-9374.
- Geller, C. A., J. K. Weissel, and R. N. Anderson. 1983. Heat transfer and intraplate deformation in the central Indian Ocean. *J. Geophys. Res.* 88:1018-1032.
- Hanks, T. C. 1979. Deviatoric stresses and earthquake occurrence at the outer rise. *J. Geophys. Res.* 84:2343-2347.
- Hayes, D. E., and M. Ewing. 1970. Pacific boundary structure. In *The Sea, Ideas and Observations on the Progress in the Study of the Seas*, Vol. 4, Part II, edited by A. E. Maxwell, pp. 29-72. Wiley-Interscience.

- Hilde, T. W. C. 1983. Sediment subduction versus accretion around the Pacific. *Tectonophysics* 99:381-397.
- Hilde, T. W. C., and G. F. Sharman. 1978. Fault structure of the descending plate and its influence on the subduction process. *Eos Trans. AGU* 59:1182.
- Hobart, M. A., and C. A. Stein. 1987. Deformation, heat flow, and the Wharton Basin, Indian Ocean. *Eos Trans. AGU* 68:408.
- Kieckhefer, R. M., G. G. Shor, Jr., J. R. Curray, W. Sugiarta, and F. Hehuwat. 1980. Seismic refraction studies of the Sunda Trench and forearc basin. *J. Geophys. Res.* 85:863-889.
- Lawver, L. A., and V. Vacquier. 1977. Heat flow in the Sunda transect. *Eos Trans. AGU* 58:1233.
- Levchenko, O. V., L. R. Merklin, and A. A. Schreider. 1986. Structural and geodynamic features of the Sunda Trench. *Geotectonics* 20:238-244.
- Lister, C. R. B. 1962. Heat flow through the ocean floor. Ph.D. Dissert., Cambridge University.
- Liu, C. S., J. R. Curray, and J. M. McDonald. 1983. New constraints on the tectonic evolution of the eastern Indian Ocean. *Earth Planet. Sci. Letts.* 65:331-342.
- McAdoo, D. C., and D. T. Sandwell. 1985. Folding of oceanic lithosphere. *J. Geophys. Res.* 90:8563-8569.
- Melosh, H. J. 1978. Dynamic support of the outer rise. *Geophys. Res. Letts.* 5:321-324.
- Moore, G. F., and J. R. Curray. 1980. Structure of the Sunda Trench lower slope off Sumatra from multichannel seismic reflection data. *Mar. Geophys. Res.* 4:319-340.
- Newcomb, K. R., and W. R. McCann. 1987. Seismic history and seismotectonics of the Sunda Arc. *J. Geophys. Res.* 92:421-439.
- Parsons, B., and J. G. Sclater. 1977. An analysis of the variation of ocean floor bathymetry and heat flow with age. *J. Geophys. Res.* 82:803-827.
- Schweller, W. J., L. D. Kulm, and R. A. Prince. 1981. Tectonics, structure and sedimentary framework of the Peru-Chile Trench. *Geol. Soc. Am. Memoir* 154:323-349.
- Sclater, J. G., and R. L. Fisher. 1974. The evolution of the east central Indian Ocean, with emphasis on the tectonic setting of the Ninety-east Ridge. *Bull. Geol. Soc. Am.* 85:683-702.
- Taylor, P. 1965. Interpretation of the heat flow pattern from the Sumatra Trench. Ph.D. Dissert., Stanford Univ.:69 pp.
- Taylor, P. 1966. Geothermal and magnetic survey off the coast of Sumatra. *Bull. Earthquake Res. Inst.* 44:541-550.
- Udintsev, G. B., ed. 1975. *Geological-Geophysical Atlas of the Indian Ocean*. Academy of Sciences of USSR, Moscow:151 pp.
- Vacquier, V., and P. Taylor. 1966. Geothermal and magnetic survey off the coast of Sumatra. *Bull. Earthquake Res. Inst.* 44:531-540.
- Von Herzen, R., and S. Uyeda. 1963. Heat flow through the eastern Pacific Ocean floor. *J. Geophys. Res.* 68:4219-4250.
- Von Herzen, R., and V. Vacquier. 1966. Heat flow and magnetic profiles on the mid-Indian Ocean Ridge. *Phil. Trans. Roy. Soc.*, A259:262-270.
- Watanabe, T., M. G. Langseth, and R. N. Anderson. 1977. Heat flow in the back-arc basins of the western Pacific. In *Island Arcs, Deep Sea Trenches and Back-arc Basins*, edited by M. Talwani and W. Pitman, III, pp. 137-161. Maurice Ewing Series, vol. 1. American Geophysical Union.
- Watts, A. B., and M. Talwani. 1974. Gravity anomalies seaward of deep-sea trenches and their tectonic implications. *Geophys. J. Roy. Astr. Soc.* 36:57-90.
- Weissel, J. K., R. N. Anderson, and C. A. Geller. 1980. Deformation of the Indo-Australian plate. *Nature* 287:284-291.
- Wiens, D., C. DeMets, R. Gordon, S. Stein, D. Argus, J. Engeln, P. Lundgren, D. Quible, C. Stein, S. Weinstein, and D. Woods. 1985. A diffuse plate boundary model for Indian Ocean tectonics. *Geophys. Res. Letts.* 12:429-432.
- Wiens, D., S. Stein, C. DeMets, R. Gordon, and C. Stein. 1986. Plate tectonic models for Indian Ocean "intraplate" deformation. *Tectonophysics* 132:37-48.
- Wortel, M. J. R., and S. A. P. L. Cloetingh. 1986. On the dynamics of convergent plate boundaries and stress in the lithosphere. In *Origin of Arcs*, edited by F.-C. Wezel, pp. 115-139. Elsevier.

MARINE HEAT FLOW AND SEA-FLOOR TECTONICS

Richard P. Von Herzen

*Woods Hole Oceanographic Institution
Woods Hole, MA 02543*

Introduction

The measurement of heat flow through the sea floor was initiated by Sir Edward Bullard about 35 years ago (Revelle and Maxwell, 1952; Bullard, 1954). Although since then equipment and instrumentation have evolved considerably (Von Herzen, 1987), for most of the measurements the basic method continues of independently determining the vertical temperature gradient and thermal conductivity of surficial ($\leq 10\text{m}$) sea-floor sediments. Whereas in the early days, with primitive electronics and recording, it was considered fortunate to obtain perhaps 10 measurements in a one-month cruise, it is now possible to make perhaps 200 measurements over the same period on a cruise dedicated to such a program. The cumulative number of measurements is now on the order of 10^4 , distributed throughout all the major ocean basins.

My introduction to the measurement of heat flow at sea was encouraged by Russ Raitt in 1957 when a major oceanographic expedition (Downwind) was being organized at SIO to the South Pacific. Preparation of the heat-flow instrumentation for the cruise was facilitated by resurrecting that used by Art Maxwell and Roger Revelle on a similar expedition several years previously (Capricorn, 1952-53). Whereas too much space would be consumed in recounting here all the vicissitudes of the measurements and instrumentation on Downwind Expedition, the effort was generally successful (Von Herzen, 1959), thanks to the support and guidance of Russ Raitt and the help of many others on the SIO staff at that time.

Partly because most tectonic phenomena have an underlying thermal origin, and also because of the strong temperature dependence of rheology of earth materials, it is not surprising that marine heat-flow measurements can contribute to improved understanding of sea-floor tectonics. These tectonic phenomena include: 1) evolution of ocean lithosphere and crust, 2) volcanism and magma chamber cooling, 3) hot spots and mid-plate swells, 4) fracture zone tectonics, 5) subduction tectonics, 6) fluid circulation in ocean crust, 7) depth distribution of earthquakes, etc. The following discussion will attempt to summarize several selected active research areas in which heat-flow measurements play an important role. It will not be a summary of the accomplishments or understanding derived from all measurements of marine heat flow, nor a detailed discussion of instrumentation, although the latter determines to a considerable extent the nature of the problems which can be investigated.

Heat-transport Mechanisms

Although the measurement techniques generally imply that only the **conducted** heat-flow component is determined, the spatial distribution of values can elucidate important **advective** heat-transport mechanisms. The initial widely-spaced measurements in the Pacific were interpreted as evidence for large-scale convection in the underlying mantle (Von Herzen, 1959). As soon as sufficient measurements became available, in many regions it became clear that neither conduction processes nor broad mantle convection could explain the large variability at high spatial wave number (Von Herzen and Uyeda, 1963; Lister, 1972, Von Herzen and Anderson, 1972). In particular, the correlation of higher heat-flow values over locally elevated topography led to the hypothesis of hydrothermal circulation in ocean crust (Lister, 1972). The patterns of this circulation have been mapped by detailed surface heat-flow measurements on young crust where sufficient sediment cover exists (Williams *et al.*, 1974; Green *et al.*, 1981; Becker and Von Herzen, 1983a), showing wavelengths of 10-20 km with significant linearity parallel to the spreading ridge axis.

These surface heat-flow patterns near ridge crests have been modelled in both the laboratory (Williams *et al.*, 1974; Hartline and Lister, 1977) and numerically (Fehn *et al.*, 1983) in two dimensions (one vertical, one horizontal) as simulations of a permeable surface layer heated from below. The observations in the field have been reasonably well reproduced with models in which a surface layer several km thick has mean fluid permeabilities of order 10^{-13} to 10^{-15} m², either uniformly distributed or exponentially decreasing with depth. The inclusion of realistic thermodynamic properties of water in the numerical models gives asymmetric distributions of up- and downwelling parts of cellular circulation, with the ascending fluid regions more narrowly focused than the broader downwelling parts of cells; this pattern seems consistent with the surface heat-flow measurements. However, it is difficult to separate this source of asymmetry from that caused by an appropriate laterally non-uniform permeability distribution. Such a permeability distribution might be created, for example, by faulting near topographic elevations (ridges) where higher heat-flow values are frequently measured (Green *et al.*, 1981).

The actual distribution of crustal pore-water circulation patterns may be obtained best from investigations in the vertical dimension. Indeed, results from drilling show frequently that fluid permeability and flow are not uniform in the upper crust, but rather are enhanced in relatively thin (≤ 100 m) zones traversed by the drill hole (Becker *et al.*, 1983), although it is not usually possible to determine if such zones coincide with faulting. Other results of temperature measurements during drilling of sediments near the Galapagos ridge (Becker and Von Herzen, 1983b) imply vertical advection of pore-water through sediments at rates of several cm to several tens of cm per year, confirming an advective phenomenon suggested earlier by surface heat-flow measurements in other regions (Anderson *et al.*, 1979). The spatial variation of surface heat flow and non-linear distribution of certain pore-water chemical species with depth in a region of relatively thick (200-300 m) sediments near the Costa Rica rift are also evidence for pore-water advection even at relatively low rates (mm/yr), probably reflecting the circulation patterns in the underlying basement (Langseth *et al.*, 1986).

Ironically, evidence from other fields of geophysics seems increasingly favorable for the existence of large-scale convection in the mantle. Large-scale variations in velocities of seismic waves (Tanimoto and Anderson, 1985; Nataf *et al.*, 1986) may be best explained by similar scales of temperature differences in the upper mantle as a result of convection. The effects of these on surface heat flow is probably small, such that they would be difficult to distinguish from other sources of heat-flow variations.

Rifting and Plate Evolution

The mechanisms of continental rifting and their associated implications have been increasingly clarified following the plate-tectonics revolution, especially over the past decade. The recognition that the overall process of rifting produces crustal thinning, frequently in the extreme of zero thickness, led to a relatively simple model predicting depth and surface heat flow (McKenzie, 1978). After an initial rifting (crustal thinning) event, assumed instantaneous, the evolution of heat flow and depth with time is analogous to that for the oceanic lithosphere. Anomalous heat flow is predicted for only a relatively short geological time (≤ 50 M.y.) after the rifting event, such that it has been difficult to find suitable regions to test the model. Youthful rifts, such as the Red Sea and Gulf of California, are complicated by thick sediments (including salt deposition), incomplete (and perhaps non-instantaneous and inhomogeneous) rifting, and hydrothermal circulation.

A useful province to test the rifting models may be back-arc basins. Indeed, it has been found that their depths and surface heat flows correlate in a general sense with geologic age (Sclater, 1972; Watanabe *et al.*, 1977). Some marginal seas, such as the Mediterranean, appear tectonically similar to back-arc basins; the surface heat-flow variation with sea-floor age in the Mediterranean appears similar to that of the main ocean basins (Hutchison *et al.*, 1985; Jemsek *et al.*, 1985) and to other back-arc basins. An unresolved puzzle is that back-arc basins and tectonically similar marginal seas appear to have depths systematically deeper (by 0.5 to 1.0 km) than the ocean basins; this may result from the relatively dense subducted slab beneath, and might be tested by gravity measurements across the boundaries of such basins.

Of course, surface heat flow together with sea-floor depth and lithospheric age have provided the simple quantitative models of plate evolution (McKenzie, 1967; Parsons and Sclater, 1977; Sclater *et al.*, 1980). The plate model (constant-temperature lower boundary at 100-125 km depth), as compared to the half-space model, is preferred presently as it predicts that both the depth and heat flow approach asymptotic values at greater ages, which appears to correspond with observations. However, both the depth and heat flow may approach their asymptotes more quickly than predicted by the model parameters given in Parsons and Sclater (1977), at least in the North Atlantic (Davis *et al.*, 1984) and perhaps also the North Pacific (J.

Slater, pers. comm., 1985). Heestand and Crough (1981) argue that the observations may be contaminated by hot-spot tracks, and that the appropriate model without the influence of pre-existing hot spots may be the half-space model. This question touches on the nature of the earth's interior beneath the plates, as does the next topic.

Mid-Plate (Hot Spot?) Swells

These features are defined as broad (hundreds to thousands of km) regions of the sea floor with depths at least 200 to 300 m above that normally expected (referenced to the plate model). Crough (1983) identified approximately 30 such features in the ocean basins. They are frequently lineated and have volcanism (seamounts) usually distributed near the long axis of the swell (e.g., Hawaii). The swell elevation is frequently highest where the volcanism is active, and subsides with increasing age of the seamounts. The maximum anomalous swell height is frequently roughly comparable to that of 25 M.y.-old sea floor, and the subsidence rate also appears similar to the evolution of sea floor of that age. The relationship between topography and gravity over swells suggests that compensation for the swell height takes place at depths of 50-100 km, or in the lower part of a mature plate (Crough, 1978).

Heat-flow measurements recently have been made on three swells (Hawaii, Bermuda, Cape Verde) to determine if their anomalous characteristics have a thermal origin (Von Herzen *et al.*, 1982; Detrick *et al.*, 1986; Courtney and White, 1986). Somewhat higher heat flow than predicted for sea floor of similar age has been determined for all three swells. For the Hawaiian swell, the maximum heat-flow anomaly is about 20% above normal, and occurs about 20 M.y. after passing over a heat source at the island of Hawaii (assuming a uniform plate motion over the hot spot of ~10 cm/yr.). This observation is consistent with rapid (5-10 M.y.) reheating of the lower part of the plate beneath Hawaii, followed by slower conduction of the thermal anomaly to the surface after passing over the hot spot. The heat-flow anomaly may be similar for Bermuda, but the interpretation is complicated by the uncertainty of background heat flux for normal sea floor around Bermuda; furthermore, the Bermuda hot spot may be time-dependent, perhaps presently waning. For the Cape Verde Rise, the heat-flow anomaly near its center is nearly 35% above background. However, the depth anomaly of this swell is one of the largest, nearly 2 km, and it appears that dynamic uplift by convective motions beneath may be as important as lithospheric reheating in maintaining such an anomalous sea-floor elevation. Additional heat flow and other geophysical observations on other swells should help to deduce the sources of their anomalous characteristics.

It should be noted that all the recent heat-flow measurements on swells and those used to determine accurate values for old sea floor are made with the "pogo" technique. This method of measurement utilizes a high-strength probe with thermistor sensors attached, and high-accuracy ($\leq 0.001^\circ\text{C}$), digital recording with a large capacity (18-30 hrs. duration), so that many measurements can be made rapidly over small (~10 km) regions in a "pogo" (repeated penetration) fashion. *In-situ* thermal conductivity is sometimes measured during the same penetration used to determine the temperature gradient. These procedures appear to improve significantly the accuracy of a heat-flow value at any location, probably because local small-scale variability in individual measurements is statistically smoothed. This variability likely results from small-scale lateral changes in sediment physical properties, and/or refraction of heat flux from deeper structures.

Subduction

Vic Vacquier was among the first investigators to elucidate the patterns of heat flow around subduction zones (trenches). His detailed studies in the vicinity of the Indonesian trench off Sumatra showed a complicated but contourable pattern (Vacquier and Taylor, 1966). With Japanese colleagues, he investigated the heat flow near the Japan and other trenches of the western Pacific (Vacquier *et al.*, 1966). A typical profile across the trench exhibited lower-than-normal heat flow at and perhaps somewhat landward (towards the island arc) of the trench, and higher-than-normal heat flow at the island arc and in the back-arc basin. The lower heat flow at the trench was ascribed to the effect of the cold subducting slab, and the higher heat flow landward as a result of secondary convection and/or magmatism which produces the arc. A more modern plate-tectonics view is that the heat flow is higher in the back-arc basin because of its relatively recent formation, which may be caused by some form of convection in the underlying mantle.



Vic Vacquier on R/V *Argo* in the Indian Ocean, 1964. Photo by Von Herzen

Some notable exceptions to this heat-flow pattern of subduction zones have been found recently. In the Nankai trough near Japan, the heat flow in the trench is **high** where relatively young (≤ 20 M.y.) lithosphere is being subducted (Yamano *et al.*, 1984). This anomalous pattern seems confirmed by measurements across the recent subduction zone off the Antarctic peninsula where a similar tectonic situation exists (Dougherty *et al.*, 1987). In the Barbados Rise/Caribbean Arc region, higher but variable heat flow near the base of the sedimentary wedge of the over-riding plate grades to lower heat flow towards the island arc (Westbrook *et al.*, 1986). Expulsion of over-pressured (?) interstitial water at the sea floor is believed to have an important role in producing the high heat flow; it is not clear whether the trend of lower heat flow towards the arc is an effect of the subducting plate or the accumulating sediments. Sediment deformation and pore-water movements may be important for heat-flow patterns in many subduction zones where there are significant sediment thicknesses.

Summary

The investigation of surface heat flow had a less important role than other geophysical techniques (magnetics, bathymetry, seismics) in the plate-tectonics revolution primarily because of the large spatial variability and biasing effects of hydrothermal circulation in the crust. We now have a reasonable understanding of these effects and the conditions under which they occur (i.e., young sea floor, incomplete sediment cover), although important questions remain (e.g., what is the intensity of circulation and how long can it continue beneath sediment-covered crust?). Important tectonic problems are now being clarified by heat-flow measurements in combination with other geological and geophysical methods. The pioneering studies of Russ Raitt and Vic Vacquier, especially in seismic structure and geomagnetics, respectively, helped set the stage for many of these ongoing investigations.

References

- Anderson, R. N., M. A. Hobart, and M. G. Langseth. 1979. Geothermal convection through oceanic crust and sediments in the Indian Ocean. *Science* 204:828-832.
- Becker, K., M. G. Langseth, R. P. Von Herzen, and R. N. Anderson. 1983. Deep crustal geothermal measurements, Hole 504B, Costa Rica rift. *J. Geophys. Res.* 88:3447-3457.
- Becker, K., and R. P. Von Herzen. 1983a. Heat flow on the western flank of the East Pacific Rise at 21°N. *J. Geophys. Res.* 88:1057-1066.
- Becker, K., and R. P. Von Herzen. 1983b. Heat transfer through the sediments of the mounds hydrothermal area, Galapagos spreading center at 86°W. *J. Geophys. Res.* 88:995-1008.
- Bullard, E. C. 1954. The flow of heat through the floor of the Atlantic Ocean. *Proc. Roy. Soc. London* 222(A):408-429.
- Courtney, R. C., and R. S. White. 1986. Anomalous heat flow and geoid across the Cape Verde Rise: evidence for dynamic support from a thermal plume in the mantle. *Geophys. J. Roy. Astr. Soc.* 87:815-867.
- Crough, S. T. 1978. Thermal origin of mid-plate hot-spot swells. *Geophys. J. Roy. Astr. Soc.* 55:451-469.
- Crough, S. T. 1983. Hotspot swells. *Ann. Rev. Earth Planet. Sci.* 11:165-193.
- Davis, E. E., C. R. B. Lister, and J. G. Sclater. 1984. Towards determining the thermal state of old ocean lithosphere: heat-flow measurements from the Blake-Bahama Outer Ridge, northwestern Atlantic. *Geophys. J. Roy. Astr. Soc.* 78:507-545.
- Detrick, R. S., R. P. Von Herzen, B. Parsons, D. Sandwell, and M. Dougherty. 1986. Heat flow observations on the Bermuda Rise and thermal models of mid-plate swells. *J. Geophys. Res.* 91:3701-3723.
- Dougherty, M. E., R. P. Von Herzen, and P. F. Barker. 1987. Anomalous heat-flow from a Miocene ridge crest-trench collision. *Antarctic J.* (In press).
- Fehn, U., K. E. Green, R. P. Von Herzen, and L. M. Cathles. 1983. Numerical models for the hydrothermal field at the Galapagos spreading center. *J. Geophys. Res.* 88:1033-1048.
- Green, K. E., R. P. Von Herzen, and D. L. Williams. 1981. The Galapagos spreading center at 86°W: a detailed geothermal field study. *J. Geophys. Res.* 86:979-986.
- Hartline, B. K., and C. R. B. Lister. 1977. Thermal convection in a Hele-Shaw cell. *J. Fluid Mech.* 79:370-389.
- Heestand, R. L., and S. T. Crough. 1981. The effect of hot spots on the oceanic age-depth relation. *J. Geophys. Res.* 86:6107-6114.
- Hutchison, I., R. P. Von Herzen, K. E. Loudon, J. G. Sclater, and J. Jemsek. 1985. Heat flow in the Balearic and Tyrrhenian basins, western Mediterranean. *J. Geophys. Res.* 90:685-701.
- Jemsek, J., R. P. Von Herzen, J.-P. Rehault, D. L. Williams, and J. Sclater. 1985. Heat flow and lithospheric thinning in the Ligurian Basin (NW Mediterranean). *Geophys. Res. Letts.* 12:693-696.
- Langseth, M. G., M. Mottle, M. Hobart, and A. Fisher. 1986. Hydrothermal circulation in the vicinity of the DSDP 501/504 sites on the south flank of the Costa Rica rift. *Eos Trans. AGU* 67:1222 (abst.).
- Lister, C. R. B. 1972. On the thermal balance of a mid-ocean ridge. *Geophys. J. Roy. Astr. Soc.* 26:515-535.
- McKenzie, D. P. 1967. Some remarks on heat flow and gravity anomalies. *J. Geophys. Res.* 72:6261-6273.
- McKenzie, D. P. 1978. Some remarks on the development of sedimentary basins. *Earth Planet. Sci. Letts.* 40:25-32.
- Nataf, H.-C., I. Nakanishi, and D. L. Anderson. 1986. Measurements of mantle wave velocities and inversion for lateral heterogeneities and anisotropy. *J. Geophys. Res.* 91:7261-7307.
- Parsons, B., and J. G. Sclater. 1977. An analysis of the variation of ocean floor bathymetry and heat flow with age. *J. Geophys. Res.* 82:803-827.
- Revelle, R. R., and A. E. Maxwell. 1952. Heat flow through the floor of the eastern North Pacific Ocean. *Nature* 170:199-200.
- Sclater, J. G. 1972. Heat flow and elevation of the marginal basins of the western Pacific. *J. Geophys. Res.* 77:5705-5719.
- Sclater, J. G., C. Jaupart, and D. Galson. 1980. The heat flow through oceanic and continental crust and the heat loss of the earth. *Rev. Geophys. Space Physics* 18:269-311.
- Tanimoto, T., and D. L. Anderson. 1985. Lateral heterogeneity and azimuthal anisotropy of the upper mantle: Love and Rayleigh waves 100-250s. *J. Geophys. Res.* 90:1842-1858.
- Vacquier, V., and P. T. Taylor. 1966. Geothermal and magnetic survey off the coast of Sumatra. *Bull. Earthquake Res. Inst.* 44:531-540.

- Vacquier, V., S. Uyeda, M. Yasui, J. Sclater, C. Corry, and T. Watanabe. 1966. Studies of the thermal state of the earth. *Bull. Earthquake Res. Inst.* 44:1519-1535.
- Von Herzen, R. P. 1959. Heat-flow values from the south-eastern Pacific. *Nature* 183:882-883.
- Von Herzen, R. P. 1987. Oceanic heat-flow measurements. In *Methods of Experimental Physics - Geophysics*, edited by C. Samis and T. Henyey. Academic Press. (In press)
- Von Herzen, R. P., and R. Anderson. 1972. Implications of heat flow and bottom water temperature in the eastern equatorial Pacific. *Geophys. J. Roy. Astr. Soc.* 26:427-459.
- Von Herzen, R. P., R. S. Detrick, S. T. Crough, D. Epp, and U. Fehn. 1982. Thermal origin of the Hawaiian swell: heat-flow evidence and thermal models. *J. Geophys. Res.* 87:6711-6723.
- Von Herzen, R. P., and S. Uyeda. 1963. Heat flow through the eastern Pacific Ocean floor. *J. Geophys. Res.* 68:4219-4250.
- Watanabe, T., M. G. Langseth, and R. N. Anderson. 1977. Heat flow in back-arc basins of the western Pacific. In *Island Arcs, Deep Sea Trenches, and Back-arc Basins*, edited by M. Talwani and W. C. Pitman, pp. 137-161. American Geophysical Union.
- Westbrook, G., M. Langseth, and M. Hobart. 1986. Geothermal observations over the seaward edge of the Barbados Ridge accretionary prism. *Eos Trans. AGU* 67:1218. (Abst.)
- Williams, D. L., R. P. Von Herzen, J. G. Sclater, and R. N. Anderson. 1974. The Galapagos spreading center: lithospheric cooling and hydrothermal circulation. *Geophys. J. Roy. Astr. Soc.* 38:587-608.
- Yamano, M., S. Honda, and S. Uyeda. 1984. Nankai Trough: a hot trench? *Mar. Geophys. Res.* 6:187-203.

PALEOMAGNETISM OF ORIENTED DRILL CORE FROM THE ALASKAN NORTH SLOPE

Susan L. Halgedahl and Richard D. Jarrard

*Lamont-Doherty Geological Observatory
of Columbia University
Palisades, NY 10964*

The Arctic Alaska plate (Tailleur *et al.*, 1976) is the largest of the several dozen tectonostratigraphic terranes composing Alaska. This former crustal plate, comparable in size to the current Caribbean plate, is thought to include the North Slope of Alaska, Seward Peninsula, Chukotka region of Siberia, adjacent continental margins, and an unknown portion of the oceanic crust of the Canada Basin (Figure 1).

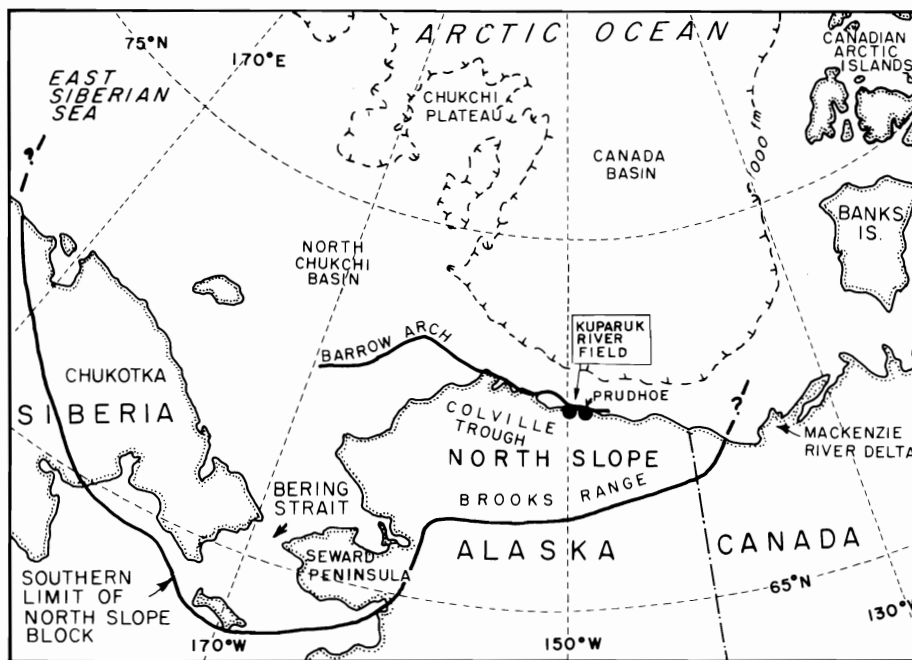

Figure 1. North Slope of Alaska and surrounding regions, including Barrow Arch, Colville Trough, Brooks Range, and Kuparuk River and Prudhoe Bay oil fields.

The tectonic history of the Arctic Alaska plate has been a subject of debate since Carey (1955) cited this region as an example of possible oroclinal bending. The major impediment to a plate-tectonic interpretation is still the paucity of marine geological and geophysical data from the adjacent Arctic Ocean, due to ice cover. Consequently, numerous models have been proposed on the basis of diverse geological correlations between the North Slope and nearby regions. These models are amenable to paleomagnetic tests through comparison of paleomagnetic poles from the North Slope with the apparent polar wander curve for cratonic North America.

Unfortunately, nearly all previous paleomagnetic studies of North Slope sediments have been plagued by a mid-Cretaceous reheating event associated with the Brookian orogeny (Newman *et al.*, 1977; Hillhouse and Gromme, 1983). By contrast, conodont and vitrinite reflectance temperatures (Harris *et al.*, 1983) suggest that the northern North Slope oil fields may contain the only pre-mid-Cretaceous rocks which escaped this reheating event.

To test models for the tectonic history of the Arctic Alaska plate, we have conducted a paleomagnetic study of cores from the Kuparuk River Formation, North Slope, Alaska. The Kuparuk River Formation is a sequence of siltstones and fine-grained sandstones, deposited in a shallow marine environment during early Cretaceous time. A regional erosional unconformity divides the formation into a lower member, thought to be mainly Valanginian in age, and an upper member that is mostly Hauterivian (John E. Bennett, pers. comm., 1986). The formation is currently a major producing hydrocarbon reservoir on the North Slope.

ARCO has continuously cored the Kuparuk River Formation at a large number of wells. Our paleomagnetic sampling focussed on three wells. Between 90 and 150 m of virtually continuous core were available from each well. Paleomagnetic samples were taken at 0.6- to 1.2-m intervals downcore. The entire Kuparuk River Formation and portions of bracketing shales were sampled at two wells (Wells 1 and 2); sampling at Well 3 was similar but excluded the upper member.

As Vacquier (1939) first pointed out, paleomagnetic studies of drill core are complicated by several factors, the most important of which is accuracy of core orienting. In this study, the cores at Well 1 were oriented only vertically, while cores from the other two wells were fully oriented with respect to geographic north. For Wells 2 and 3, core-orienting photographs were taken every 1.5 m downhole at the well site. Accuracy of these core-orienting surveys is essential to the success of our paleomagnetic study. Therefore, we tested this accuracy in several ways. First, hole-deviation photographs taken in conjunction with the core-orienting survey showed a good agreement with the benchmark gyroscopic deviation study at each well. Second, dip directions measured directly from core and oriented with the orientation survey agreed well with *in situ* dip directions measured by dipmeter. Third, the characteristic remanent magnetization (ChRM) directions of individual samples (collected at random azimuths about the core axis) showed an increased clustering after correction of directions with the orienting log. Fourth, mean paleomagnetic directions from the two wells exhibited good agreement.

The dominant magnetic carrier in the Kuparuk River Formation is probably single-domain or pseudosingle-domain magnetite, on the basis of magnetic response at low temperatures (-196 to 20°C), IRM acquisition and demagnetization curves, and remanent coercivities. Thermal demagnetization to temperatures above 150°C causes growth of a new magnetic phase, accompanied by changes in susceptibility, magnetic viscosity, and coercivity.

Characteristic remanent directions were isolated by thermal demagnetization to 230°C, followed by stepwise alternating-field demagnetization. Much of the lower member of the Kuparuk River Formation exhibited good magnetic stability, so that ChRM directions could be confidently determined from vector end-point diagrams. Unfortunately, the magnetization of the upper member was much less stable, so that it was used only for a very tentative polarity assignment for defining reversal stratigraphy.

Magnetic reversals occur in both the upper and lower member of each well. Thicknesses of individual sedimentary units, as identified either in cores or on gamma-ray logs, vary substantially among the wells. These interwell thickness variations can be removed through nonlinear mapping (Martinson *et al.*, 1982; Halgedahl *et al.*, 1983) of gamma-ray logs. After nonlinear mapping, the reversal stratigraphy of the lower Kuparuk member correlates quite well among the three wells (Figure 2) and can be matched with chrons M14-M11An (about 141-136 Ma) on the reversal time scale (Harland *et al.*, 1982; Kent and Gradstein, 1985). Correlations in the magnetically less stable upper member are highly tentative, although a polarity sequence that may represent chrons M11n-M9 is present. The reversal stratigraphy in the lower member is consistent with its probably Valanginian age (Figure 2) based on microfossils. This consistency strongly suggests that the characteristic remanence of the lower member has survived since the time of deposition. Mean directions of magnetization for normally and reversely polarized rocks are approximately antipodal, but the small number of stable, normally magnetized samples makes a reversal test inconclusive.

Determination of a pole position from the ChRM directions of oriented drill core requires three coordinate transformations. First, directions in "plug coordinates" must be transformed to "borehole coordinates," through application of the core-orienting survey. Second, deviation of the borehole from vertical must be accounted for. Gyroscopic deviation surveys at Wells 2 and 3 were used for this transformation from borehole coordinates to "geographic coordinates." Third, bedding tilt must be removed. The average structural dip for the Kuparuk River Formation at the Kuparuk field is only 1.5°, based on seismic profiles or a map of formation tops (Carman and Hardwick, 1983). However, local

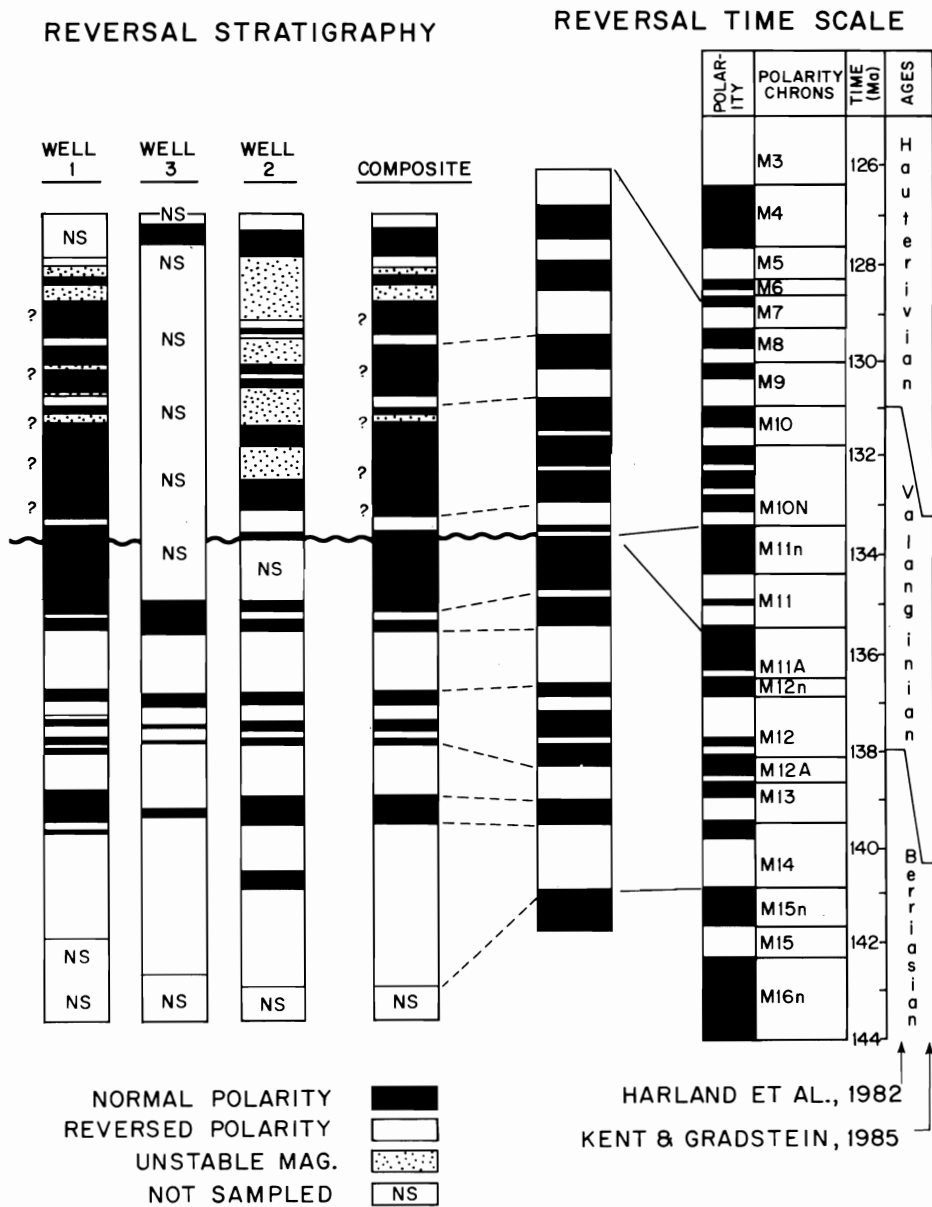

Figure 2. Reversal stratigraphy at Wells 1, 2, and 3, after nonlinear mapping against Well 1 as the standard, using "mapping functions" obtained by mapping gamma-ray logs. Note uncertainties in polarity assignments above the B/C unconformity (wavy line). Only the interval beneath the B/C unconformity is well correlated with the magnetic-reversal time scale, shown at far right. Reversal time scales for the Early Cretaceous are taken from Harland *et al.* (1982) and from Kent and Gradstein (1985).

structural dip can vary by up to 5° between wells, due to tilting associated with small offset normal faults. For transformation of paleomagnetic directions from geographic coordinates to "stratigraphic coordinates," the local structural dip should be known. Local structural dips for Wells 2 (strike 92°, dip 5.6° SW), and 3 (strike 75°, dip 2.5° SE) were determined from analysis of dipmeter data.

Paleomagnetic poles were calculated in geographic and stratigraphic coordinates, based on the ChRM directions of 46 samples from Well 2 and 43 samples from Well 3. Tilt correction to stratigraphic coordinates increases the consistency of poles from the two wells, but the small dip corrections make a tilt test inconclusive. Both before and after tilt corrections, the mean directions at each well are quite different from both the present-day fields and axial dipole fields at the wells. Further, the mean pole positions are significantly different from the entire apparent polar wander path for cratonic North America from the

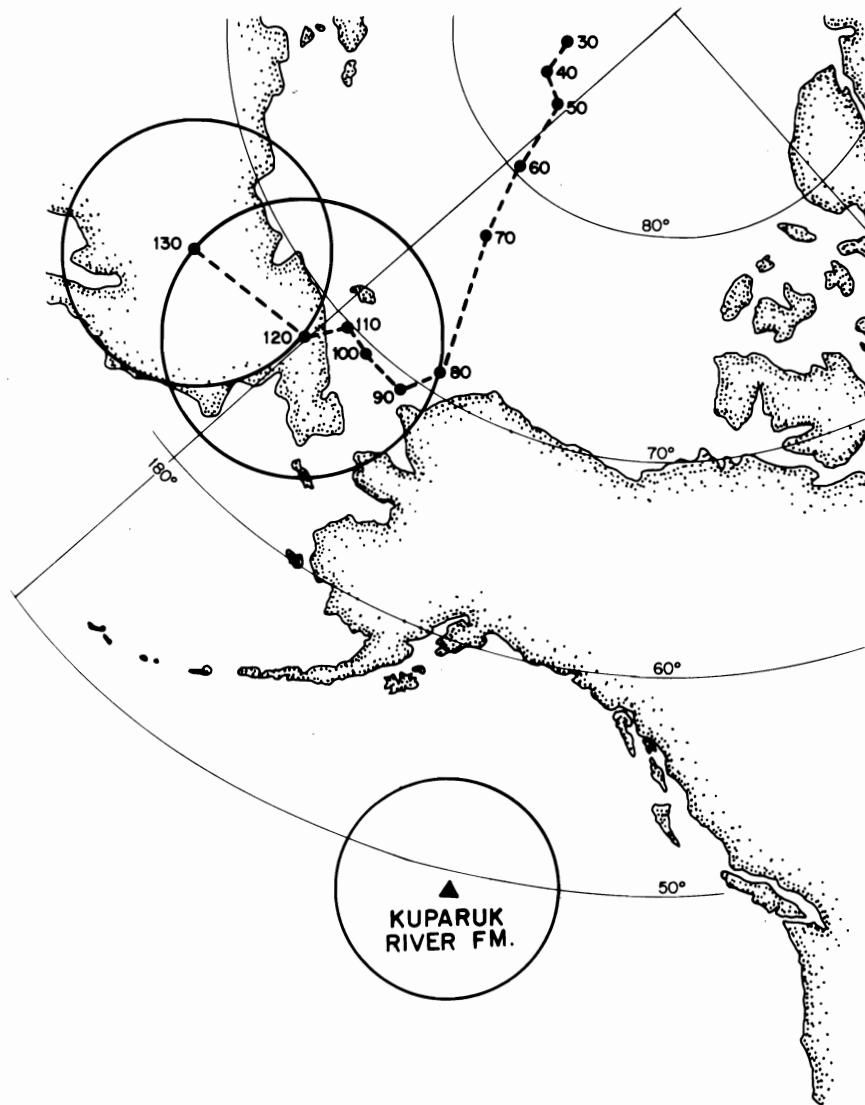

Figure 3. Paleomagnetic pole of the Kuparuk River Formation from combined results from Wells 2 and 3 after tilt correction, and the APW path for cratonic North America (Harrison and Lindh, 1982). Note that the Kuparuk River pole is largely derived from the mostly Valanginian lower member. The most appropriate point on the APW path for comparison to the 136-141 m.y. Kuparuk River pole falls at 120 m.y., because of differences in geological time scales used by the two studies. The discrepancy between the Kuparuk River pole and the 120 m.y. pole for North America suggests that models in which the North Slope has remained in its present position since the Jurassic are precluded.

Lower Cretaceous to the present day (Figure 3). This difference, as well as the correlation of reversal stratigraphy with the Lower Cretaceous reversal time scale, indicates that no remagnetization occurred during the mid-Cretaceous Brookian orogeny, a time of prolonged normal polarity. Also, no remagnetization could have occurred during the Tertiary (e.g., during oil migration), unless substantial tilting both preceded and followed remagnetization. However, two-stage tilting appears unlikely, based on conformable Tertiary seismic stratigraphy in the region.

Assuming that the Kuparuk River Formation acquired its characteristic magnetization in Neocomian time, the North Slope cannot have been in its present location relative to North America at that time (Figure 3). Models which place the North Slope in its current location since the Jurassic or Paleozoic are precluded (e.g., Herron *et al.*, 1974; Fujita, 1978; Churkin and Trexler, 1980; Vogt *et al.*, 1982). The difference between the mean Kuparuk River pole and a similar aged composite pole for cratonic North America indicates that motion of the Arctic Alaska plate occurred subsequent to Neocomian time.

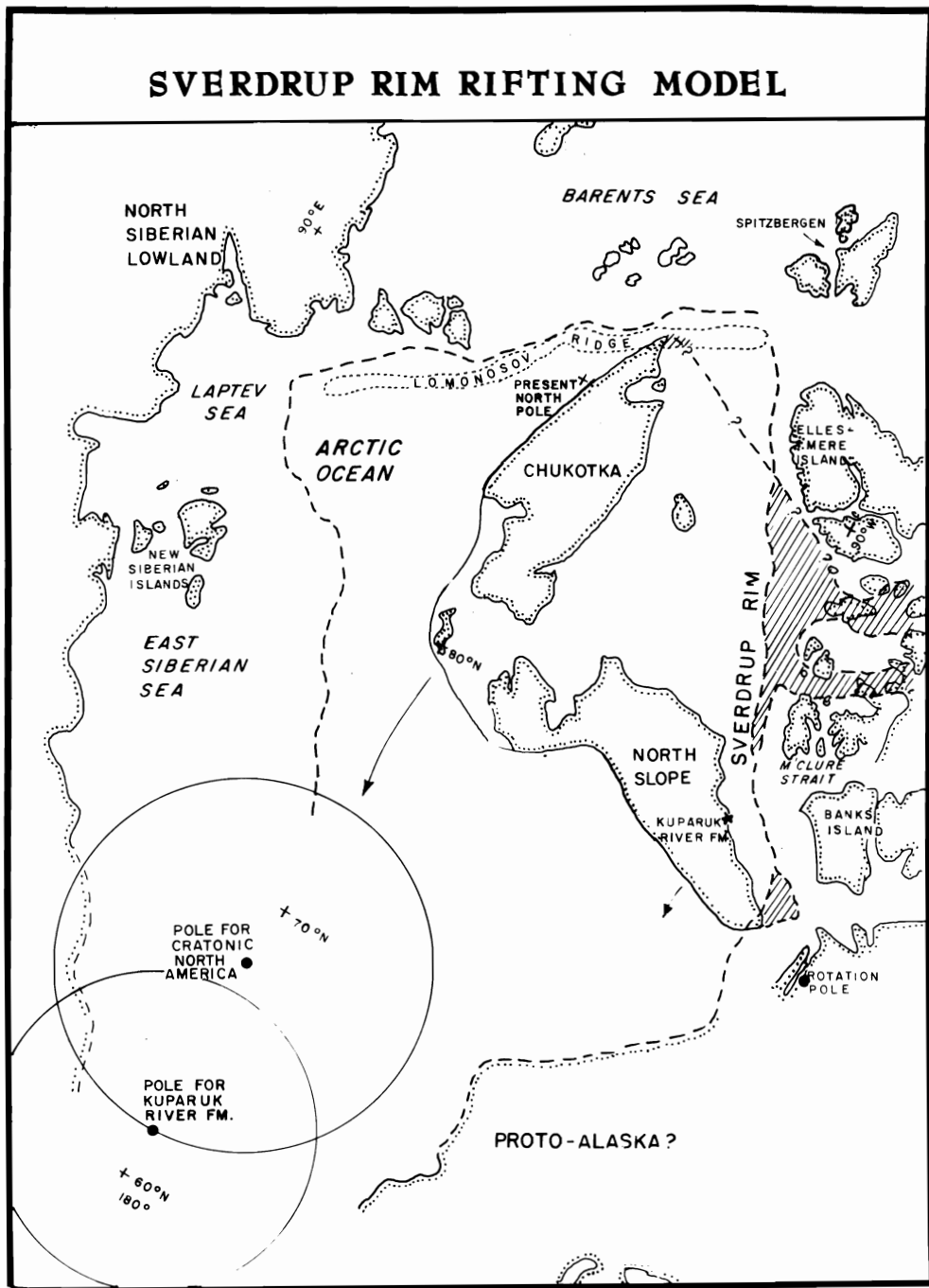

Figure 4. Comparison of the mean Kuparuk River paleomagnetic pole to the 120 m.y. pole for cratonic North America (Harrison and Lindh, 1982), after reconstruction according to the "rotational" or "Sverdrup rim rifting" model. Cretaceous and Tertiary relative motions between North America and Eurasia are removed. The rotational model suggests that the Arctic Alaska plate was originally adjacent to the Sverdrup Rim of Arctic Canada and rotated to its present location about a finite rotation pole in the Mackenzie River delta region. This model is the only published model for Arctic plate motions that is consistent with Kuparuk paleomagnetic data.

Models for the former location of the Arctic Alaska plate can be tested, by comparing the Kuparuk River pole position to the Neocomian pole for cratonic North America, after restoration of the North Slope to its hypothesized former position. The dextral slip model of Jones (1980, 1982), which places the North Slope originally south of its present location and adjacent to the Canadian Yukon, only increases the discrepancy between the Kuparuk and North American poles. The model of Dutro (1981), which suggests that the North Slope rifted away from the Lomonosov Ridge, similarly fails to reduce the discrepancy.

The only existing model which is compatible with the Kuparuk River paleomagnetic pole is that for 65-70° of counterclockwise rotation of the Arctic Alaska plate away from Arctic Canada, about a finite rotation pole near the Mackenzie Delta (Figure 4). This model, hypothesized by Tailleux (1969), Grantz *et al.* (1979) and others, produces an acceptable overlap of the Kuparuk and Neocomian North American poles. The reversal stratigraphy and pole position of the Kuparuk River Formation suggest that the North Slope was still adjacent to the Sverdrup Rim of Arctic Canada at about anomaly M11An time, or about 136 Ma. By this interpretation, the erosional unconformity between the upper and lower members of the Kuparuk River Formation may be associated with pre-breakup crustal doming. Normal faulting during deposition of the upper member (Masterson and Paris, 1987) may be associated with the earliest crustal stretching. Subsequent drift of the Arctic Alaska plate away from Arctic Canada created the Canada Basin (Tailleux, 1969). The agreement of mid-Cretaceous remagnetizations from the Brooks Range with the 100 m.y. pole for cratonic North America (Hillhouse and Gromme, 1983) suggests that drift concluded before about 100 Ma, by collision of the drifting plate with a trench adjacent to what is now the Yukon-Kuyuk Basin.

References

- Carey, S. W. 1955. Orocline concept in geotectonics. *Roy. Soc. Tasmania Proceedings Paper*, 89:255-288.
- Carman, G. J., and P. Hardwick. 1983. Geology and regional setting of the Kuparuk oil field, Alaska. *Bull. Am. Assoc. Petrol. Geol.* 67:1014-1031.
- Churkin, Michael, Jr., and J. H. Trexler, Jr. 1980. Circum-Arctic plate accretion — isolating part of a Pacific plate to form the nucleus of the Arctic Basin. *Earth Planet. Sci. Letts.* 48:356-362.
- Dutro, J. T., Jr. 1981. Geology of Alaska bordering the Arctic Ocean, in *The Ocean Basins and Margins*, Vol. 5, The Arctic Ocean, edited by A. E. M. Nairn, M. Churkin, Jr., and F. T. Stehli, pp. 21-36. Plenum.
- Fujita, K. 1978. Pre-Cenozoic tectonic evolution of northeast Siberia. *J. Geol.* 86:159-172.
- Grantz, A., S. Eittreim, and D. A. Dinter. 1979. Geology and tectonic development of the continental margin north of Alaska. *Tectonophysics* 59:263-291.
- Halgedahl, S. L., R. D. Jarrard, and C. G. Martinson. 1983. Enhanced seismic interpretation through a nonlinear method of signal correlation. *Soc. Expl. Geophys. Expanded Abstracts*:555-557.
- Harland, W. B., A. V. Cox, P. G. Llewellyn, C. A. G. Pickton, A. G. Smith, and R. Walters. 1982. *A Geologic Time Scale*. Cambridge University Press. 131 pp.
- Harris, A. G., I. F. Ellersieck, C. F. Mayfield, and I. L. Tailleux. 1983. Thermal maturation values (conodont color alteration indices) for Paleozoic and Triassic rocks, Chandler Lake, DeLong Mountains, Howard Pass, Killik River, Misheguk Mountain, and Point Hope quadrangles, northwest Alaska, and subsurface NPRA. *U. S. Geol. Survey Open-File Report* 83-505, 15 pp.
- Harrison, C. G. A., and T. Lindh. 1982. A polar wandering curve for North America during the Mesozoic and Cenozoic. *J. Geophys. Res.* 87:1903-1920.
- Herron, E. M., J. F. Dewey, and W. C. Pitman, III. 1974. Plate tectonics model for the evolution of the Arctic. *Geology* 2:377-380.
- Hillhouse, J. W., and C. S. Gromme. 1983. Paleomagnetic studies and the hypothetical rotation of Arctic Alaska. *J. Alaska Geol. Soc.* 2:27-39.
- Jones, P. B. 1980. Evidence from Canada and Alaska on plate tectonic evolution of the Arctic Ocean Basin. *Nature* 285:215-217.
- Jones, P. B. 1982. Mesozoic rifting in the western Arctic Ocean Basin and its relationship to Pacific sea-floor spreading, in *Arctic Geology and Geophysics*, edited by A. F. Embry and H. R. Balkwill, Canada Soc. Petr. Geol. Memoir 8, pp. 83-99.
- Kent, D. V., and F. M. Gradstein. 1985. A Cretaceous and Jurassic geochronology. *Bull. Geol. Soc. Am.* 96:1419-1427.

- Martinson, D. G., W. Menke, and P. Stoffa. 1982. An inverse approach to signal correlation. *J. Geophys. Res.* 87:4807-4818.
- Masterson, W. D., and C. E. Paris. 1987. Depositional history and reservoir description of the Kuparuk River Formation, North Slope, Alaska, in *Geology of the Alaskan North Slope*, edited by E. L. Tailleur. SEPM. In press.
- Newman, G. W., C. G. Mull, and N. D. Watkins. 1977. Northern Alaska paleomagnetism, plate rotation, and tectonics, in *Relationship of Plate Tectonics to Alaskan Geology and Resources*, edited by A. Sisson, C1-C7. Alaska Geological Society.
- Tailleur, I. L. 1969. Rifting speculation on the geology of Alaska's North Slope. *Oil & Gas J.* 67:128-130.
- Tailleur, I. L., C. G. Mull, and G. H. Pessell. 1976. Geologist calls Prudhoe one of a kind. *Oil & Gas J.* 74:32.
- Vacquier, V. 1939. A proposed geophysical method for orienting cores. *Geophysics* 4:292-299.
- Vogt, P. R., P. T. Taylor, L. T. Kovacs, and G. L. Johnson. 1982. The Canada Basin: aeromagnetic constraints on structure and evolution, in *Structure of the Arctic*, edited by G. L. Johnson and J. F. Sweeney. *Tectonophysics* 89:295-336.

AFTER-DINNER REMARKS*

Presiding: George G. Shor, Jr.

*Scripps Institution of Oceanography
University of California, San Diego
La Jolla, California 92093*

Shor: It is not entirely clear to me why I am presiding at this evening session. I suspect that it is because I have somehow acquired the undeserved reputation of being part of the "corporate memory" of Scripps. I therefore have to precede all of the remarks and stories that may follow with a disclaimer: my memory is just as bad as anyone else's. Many of the things that I remember very clearly probably never happened, and some of them undoubtedly happened at some other time to other people. I also want to assure both Russ and Vic that this is not "This is your life," and we will not present any forgotten acquaintances from Tahiti or Ceylon, or engage in overblown praise more than is deserved.

The following things may occur in this session: First, I will read a few messages from people who couldn't be here. Second, Roger Revelle will keep his promise to talk on a subject of his own choosing. We did not ask him to be brief. I, at least, can listen to Roger for any length of time he chooses. After that, the meeting will be open for anyone who wishes to speak about aspects of the scientific work of Russ and Vic that were omitted in today's sessions, or tell relevant sea stories. Equal time will then be given to Vic and Russ for rebuttal.

To begin, in addition to brief notes from Roger Anderson, Bill Normark, Tony Rees, Bill Nierenberg, and others who cannot be here, there are longer letters from John Knauss and Fred Spiess, which represent significant contributions to today's symposium. First, the letter from Fred Spiess, who is on a plane back from Washington at the moment:

It is not surprising that for any MPL senior staff meeting at least two members should be away from San Diego, either at sea or contributing to some advisory committee or scientific meeting. In this case Fred Fisher and I are the ones who can be here only in spirit to help celebrate the achievements of Russ Raitt and Vic Vacquier.

With Carl Eckart, Russ Raitt symbolizes for me our laboratory's beginnings — that era beyond my personal experience in which UCDWR, the wartime Research Division of the University of California, was transformed into MPL, a peacetime source of national strength, innovation and knowledge about the ocean. I came from my own undersea origins to find the excitement and satisfaction of struggling to extract data from the ocean, following Russ Raitt's example. In the early stages of MPL's existence Russ personified the persistent seagoing scientific effort which must remain the essential element of oceanography in the future. No amount of manipulating satellite pictures or stirring numbers in a supercomputer will solve our problems unless some of us go out and explore the real ocean and the sea floor beneath it as Russ and Vic have done.

Vic flew into our midst on the wings of inventiveness which brought him into contact first with the airborne Navy and through that path to MPL. Once he was here he became a model for experimental marine geophysicists — visualizing problems and the means for their solution and then making the new devices work for him in the oceanic environment.

Although Russ and Vic were rarely collaborators in research, they did combine to generate a major contribution to the life of MPL in the 60s. They forged the links to the U. K. academic community that brought us a steady flow of young post-docs. John Sclater, Chris Harrison, Mike Fuller, John Mudie, Tim Francis and Tony Rees all kept us on our toes and made this an exciting place for both staff and students. Those of us who were spending our time either at sea or in workshops and committee meetings in the U. S. were most grateful for the breadth and stimulus that these contacts added to our lives.

* Dinner held at the Kona Kai Beach and Tennis Resort, San Diego, CA

This concept of interaction among all members of the staff, and our dedication to testing ourselves and our ideas against the real ocean have been essential elements of MPL in the past 40 years. I trust they will continue in spite of changing patterns of funding and administration. The styles of research support may change, but the ocean is still out there challenging us to discover its secrets and rewarding us with calm sunny days after we brave the storm.

I hope you all are enjoying this celebration and are imagining new victories in a future built on remembrance of past achievements.

Our thanks for some of those achievements go to Russ and Vic with best wishes for their futures.

Fred Noel Spiess*

Director
Institute of Marine Resources
University of California
La Jolla, California 92093

Shor: John Knauss writes as follows:

Of all the Scripps parties to which I have received invitations in the last few years, the one I would most like to attend is the one you are arranging for Russ Raitt and Vic Vacquier on the occasion of their 80th birthdays. Unfortunately I will be in Victoria, Canada on that date at a meeting I cannot escape.

I remember Russ and Vic as friends, teachers and shipmates. It was from Russ Raitt I learned one of my most valuable lessons as a seagoing scientist. Most of us are a bit less efficient working at sea than on land, and the rougher the seas the lower the efficiency. When your efficiency slips to ten percent, you are seasick, whether or not you are still capable of ingesting and holding food. It was Russ who taught me to commit to a notebook your entire game plan before going to sea, and each night take out that notebook to be certain you are doing everything you had planned. When the seas are rough, it is tempting to cut corners and convince yourself that one more observation does not make that much difference; but when you are back in the lab on land, you know you should have hung in there. It is my recollection that Russ's tolerance of heavy seas was somewhat below average, but apparently he always dug out that notebook and he hung in there. The results of that self-discipline are evident in his published works.

My fondest memory of Vic Vacquier is of a different kind. On a cruise together in 1958, he had the good luck and the good sense to bring the first Polaroid camera ever seen at the far end of Tahiti. His instant photographs brought an entire reef fishery to a grinding halt as natives clamored for his photographs. It was just one more example of the Vacquier joie de vivre that he brings to all of his work and to his life. Please give them my best regards. I am sorry I will miss the party.

John A. Knauss

Dean
Graduate School of Oceanography
University of Rhode Island
Narragansett, RI 02882

*Director of the Marine Physical Laboratory from 1958 to 1980.

Shor: What I can say for myself is:

Russ and Vic share with many of us here a belief in the truth of a long-ago statement by Roger Revelle: Oceanography is fun. (It was frequently quoted bitterly when everything was going wrong and the weather was lousy.) Going to sea is fun if you are there to do something, not just be a spectator. (I occasionally tell people that the reason I came to Scripps was simply that I was offered the opportunity to do two things I enjoy most: go to sea and set off explosions, and that surprisingly they were willing to pay me to do it.) Russ and Vic made it more fun for everyone else by the contagion of their enthusiasm, by their unselfishness, and by not worrying terribly much who got the credit.

I worked closely with Russ for 25 years. Russ has always had a high regard for the sanctity of original data, unsullied by subjective manipulations, and an extreme passion for accuracy. This created a minor conflict between us, since I was always sloppy about calibrations, and addicted to a degree of subjectivity best defined as drawing a straight line through one point and a guess. (Russ has always been kind; he never said that.) On the other hand, I always had to guard against the possibility that Russ might some time concentrate on an idea and absent-mindedly forget that he had a half-pound charge and a lighted fuse in his hand. I also frequently had to harass him to get his part of a paper written without making one more analysis just to check the data. It was a comfortable and productive collaboration. I shall always be grateful to him for his extreme tolerance over that quarter-century of Moho hunting.

And now, I would like to have Roger talk.

Roger Revelle*

*University of California, San Diego
La Jolla, California 92093*

I have always thought that physicists were sticklers for accuracy, and that oceanographers don't know much about accuracy or precision or doing things right. I admire physicists from afar. But I've made a careful investigation of the situation tonight, and it turns out that neither Russ nor Vic are anywhere near 80 years old. They may become 80 some time in 1987 — Vic in October, I think Russ in September. They claim, I guess, they're somehow thinking of themselves as Chinese, that they are in their 80th year. You know the Chinese say that they are one year old the day they are born, sort of like a racehorse. And if that's the case we may be able to concede that there's something to this 80-year-old business. I think it is just a dramatic desire to double the age of the Marine Physical Laboratory, which really did become 40 years old some time this summer.

I thought I might say a word about the Marine Physical Laboratory, how it started. We've talked about Russ and Vic all day, but people have not said much about the laboratory. Maybe some of you do not really know much about how it began.

During World War II here in San Diego there was something called the University of California Division of War Research. Many scientists became part of the laboratory, including a few oceanographers. But when the laboratory first started, it was inhabited largely by physicists from Berkeley: the great Ernest Lawrence, the inventor of the cyclotron; Ed McMillan, the discoverer of plutonium; and several other physicists. Lawrence said, "These oceanographers don't really know what they are doing — the idea that you look for submarines with underwater sound is ridiculous. The way to look for them is with light and electromagnetic radiation." The physicists built the biggest searchlight that had ever been built, millions and millions of candlepower, and they built a big black sock — several hundred feet long and about 30 feet in diameter. The idea was that you could turn the searchlight on and see this sock, see it from thousands of feet, thousands of yards, maybe miles. Well, they turned it on, a glaring light; they could barely see the black sock about a hundred feet away. So the physicists decided that maybe finding submarines was not

*Director of Scripps Institution of Oceanography from 1950 to 1964.

really very good physics, and they all went away. Of course, where they went away to was Los Alamos — and the development of the atomic bomb. I think from the standpoint of humanity all of us might have been better off if they had stayed in San Diego.

Before the end of the war, in 1945, the University of California Division of War Research and the other components of the wartime effort rather rapidly faded away. I was at that time with the Bureau of Ships in Washington in the Navy Department, and we were very much impressed by what good work the laboratory had done in underwater sound, which *is* really the way to look for submarines. And how much there was still to do, how much science there was still to do.

The moving spirit of this enterprise in Washington was an astronomer named Lyman Spitzer. He is one of the great astronomers of our generation, and I believe one of the great intelligences of our generation. He has an IQ of about 180. My IQ is about 140, so that I was always trailing along behind him at a respectable distance. Lyman and I together wrote a letter — as you may know, in the Navy you never write a letter you sign and you never sign a letter you write. We wrote a letter for the Chief of the Bureau of Ships [Vice Admiral Edward L. Cochrane] to sign. It was a revolutionary letter to President Robert Gordon Sproul of the University of California. It said to President Sproul that the Bureau of Ships of the Navy Department wanted the University of California to establish a laboratory under the direction of a particular man, named Carl Eckart, and if the University established this laboratory, the Bureau of Ships would give it tenure — which meant that we would support it indefinitely, without limit of time, as long as the Navy existed as a Navy and was concerned with submarines.

This was an unprecedented thing for anybody in the government to do. We operated on one-year or at the most two-year contracts, and the idea of support for an unlimited time was quite shocking to Admiral Cochrane. So he sat on this letter for seven or eight months.

We went to see him from time to time about the letter, and he said, "Well, I'm thinking about it." And finally in January of 1946, he actually signed the letter. (I recently got a copy of it from the Archives at the Scripps Institution of Oceanography.) Then it turned out that we had an equally difficult time persuading the University of California. President Sproul and [business manager] Bob Underhill and the other officers of the University were not at all certain that they wanted to cooperate with the Navy or that they wanted to do anything in underwater sound or that they wanted to do research that would be paid for by the federal government. It's hard to believe now, but that's the way it was in 1946.

It was not until the summer of 1946, six months after Admiral Cochrane signed this letter and sent it to Berkeley that President Sproul and the regents agreed that maybe they could do this. And all this time Carl Eckart was wanting to go back to the University of Chicago. I would have to come out and hold his hand every two weeks or so and tell him, "It's going to happen pretty soon now, Carl." And it finally did happen of course, and the regents and the President of the University did agree to accept this contract with the Navy. Carl Eckart did become the director of the laboratory and professor of marine physics in the University of California.

The very first thing he did was to ask Russ Raitt to join him. Russ was the first appointee of the Marine Physical Laboratory, after Carl of course. He was appointed associate professor; in other words he got tenure too. This was a wonderful thing, a great coup on Lyman's part and my part and Carl Eckart's part and everybody connected with the University and the Navy who got Russ Raitt into this business.

Russ and Vic between them were two of the heroes of what I think of as the new age of exploration. Between about 1948 and 1975 a part of the world that was never really understood or known before was discovered and explored and partly at least understood: that's the bottom of the ocean, the bottom of the deep sea which covers about two-thirds of the entire earth. This age of discovery, it seems to me, ranks in the same league as the great ages of discovery in the 17th and the 18th centuries. I'll admit that my hero is Captain Cook, and none of us were quite as good as Captain Cook, but among all of us we really changed man's understanding of the world. Two of the people who did this were Russ Raitt and Victor Vacquier, in a series of great expeditions. There are other people in this room who were involved: Bob Fisher was one; Dick Von Herzen; Art Raff; Art Maxwell; several others are dead: Bill Menard; Teddy Bullard; Maurice Ewing; — many people were involved, maybe 50 people altogether were participants in this new age of exploration, as leaders of the enterprise. Of course, there were lots of people who helped out enormously, without whom the work could not have been done.

So this, it seems to me, is the real justification for celebrating Vic and Russ tonight. They were heroes of the new age of exploration.

Finally, what we are having is a family party. In the first place there are many members of the family here; I've just been counting up Russ's progeny around him: Martha and Chris [Harrison] and their two children; Craig and Kayo and Monique [Biddle]; Alison and Dick and Vickie [Gist]. We miss Helen, of course, that wonderful shipmate and loving woman, that warm-hearted woman who while she was alive was in many ways the heart of the Scripps family. In Vic's case, young Vic and his wife, and Vic's wife

[Mikoho] herself; all of them are here. In addition we're all part of the extended family of Russ and Vic — and of the others who have worked together so effectively and so loyally and so generously in this enterprise that I was talking about.

I'd like to propose a toast: to Vic and Russ and to all of the extended families of the Raitts and the Vacquiers.

Shor: There are some people here who go back to the era Roger was speaking about, and even a little farther back. I would like to ask Ray Peterson to stand up; he represents an era of Russ's life back before any of us can remember, back in the 1930s.

Raymond A. Peterson*

I should say, unaccustomed as I am to public speaking, I can gather a few thoughts here, perhaps together — if you'll pardon it being just a little personal, because my memory is around personal experiences. One of my early great friendships and delights was with Russ Raitt. I think Russ graduated around 1927 or 1928 at Caltech, and he went to work for Hercules Powder Company. His job was designing the little sticky black pitch that you put in the top of blasting caps, which was really the beginning of Russ's career.

But after a while I think he got a little tired of that sticky gooey stuff, so he went back to Caltech for several years. This was a little after the Depression. In 1935, 36 and 37 we worked together with a little company — Josh Soske was president — called Geophysical Engineering Corporation. I was out in the field, crossing canals, hiring and firing people, and Russ was in doing really heavy scientific work. Those of you familiar with reflection seismograph work remember that velocity generally increases with depth in the ground and if you have a very simple case, where the velocity increases in a linear fashion, then the wave fronts are circles which are descending with time, and ray paths are circles, everything is circular. Russ really went to work on that and taught me what I knew about the subject. Later on, some time, I was working with United Geophysical; we were working for Shell, and they were working with linear increases of velocity with depth. So all this knowledge I gained from Russ really paid off for me. I really should credit Russ; the boss gave me a Lincoln Zephyr to drive around in, and several other things.

In 1937 the company ended; I don't know how Russ stayed on a little longer; we had pretty good sign on the books, but there was no cash in the till to pay us, so we had back salary chits. So I couldn't carry on; I went to Caltech for a quarter there, and then I got out and went with another company, United Geophysical. Then, in 1941 Louis Slichter of UCLA implored me to come down to San Diego; I did a little magnetometer work here he had to get done. So I went to my boss and said Louis Slichter wants me to come down to the NDRC lab at Point Loma, and he said "Well, you can't do it unless you get a replacement," and at that time I got Hewitt Dix. Well, I came down here and was three or four months down in La Jolla. One thing I particularly remember is Pauline, my wife, went out and bought a house for \$4500, right on Curtis Street [on Point Loma], and we put a thousand dollars into fixing it.

Then, come January of 1942, there was great interest in magnetic airborne detection of submarines, so I was told to go back on Monday morning to the office of T. D. Shay in New York City. So I did; I didn't know just what was coming up, but there was a line of about 75 people, and they went all around and gave everybody jobs. Well, I was about [number] 73, and they finally came to me and said, "Can you service amplifiers?" I said, "In a very crude way." They said, "Can you solder?" I said, "I can hold a soldering iron." Then they said, "What in the hell have you been doing?" I said, "Well, supervising geophysical crews." They said, "Supervisor? You go up to Quonset Point, Rhode Island and supervise the lab." I went up there right away, and found a lot of people milling around, including Vic Vacquier and another one who later won the Nobel prize, and several other distinguished people. Nobody had told anybody I was coming, so I got up on a chair and whistled, and said, "Fellows, I'm your new supervisor."

*1946 Midlothian Drive, Altadena, CA 91001

I had a very nice nine months with Vic Vacquier. At the end of the year I went back into geophysical work. Later on, we built a magnetometer, and we discovered a very valuable copper mine with it, and a lot of credit goes to Vic for instructing us on how to make magnetic measurements. I'm greatly deeply grateful to Russ and Vic — and they're great fellows.

Shor: We also have with us one of the original staff members of the Marine Physical Laboratory; there were five in the original list: Russ, Carl Eckart, Finn Outler, Robert Young, and a young graduate student named Bill Kellogg. Bill, will you come up and say a bit about the beginnings?

William C. Kellogg*

It's a real pleasure for me to be here. It was about 40 years ago, I — just out of the U. S. Air Force, graduate of the Colorado School of Mines, attendee at NYU in meteorology, at Harvard in electronics, at MIT in radar — came on a family that used to live where I still live: Altadena. This was the Raitt family in La Jolla. For reasons best known to Russell Raitt, he selected me to be his assistant. We journeyed from time to time out San Diego Bay and around Point Loma in a boat known as the motor vessel *Jasper*. Whether the motor vessel *Jasper* still remains afloat I don't know.** It was on missions of sonar reflections from the bottom. Russ was conducting this as part of his assignment at the Marine Physical Lab. Little did I realize what a privileged position I had in those days, but my interests were perhaps more in the worlds of action than in academics. I didn't last very long with Russ. I am indeed grateful for having had that experience. The action led me later to a career in airborne geophysics, and of course the tool of the trade was the Gulf magnetometer invented by Victor Vacquier. Both of these gentlemen have affected my life, and I am indeed proud and pleased to be here to say these few words tonight, and to wish them both congratulations.

Shor: I forgot a letter that Gerry Morris brought out, which I shall read:

On behalf of the management and staff of the Naval Ocean Research and Development Activity (NORDA), it is my genuine pleasure to extend congratulations to you and the members of the Marine Physical Laboratory on the 40th anniversary of MPL's establishment. The people of NORDA are proud to salute Dr. Russell Raitt and Dr. Victor Vacquier, in whose honor this special symposium is held and wish MPL a very happy birthday.

Sincerely,

*A. C. Esau
USN, Commanding Officer*

*425 E. Las Flores Drive, Altadena, CA 91001

**Several in the audience called out yes; after World War II the ship resumed its former name *Stranger*.

[Shor called for others from the audience, and Raitt volunteered.]

Russell W. Raitt*

I just have a footnote to add to what Roger already said about the beginning of the Marine Physical Laboratory. I think some of us were only slightly aware of all of the activities going on with Roger and Lyman Spitzer. But I think we were aware of the fundamental idea. During the wartime laboratory we discovered that the study of the oceans was a really undeveloped scientific field. However, there was this series of reluctances: the reluctance of the Admiral to sign the letter, and the reluctance of President Sproul to go ahead with this scheme worked out by Roger and Lyman Spitzer.

There was a third reluctance. The Academic Senate of UCLA was unwilling to go ahead with the idea of granting tenure, and it took two years for me and I believe also Robert Young to achieve appointment as associate professor. I don't know whether you knew that, Roger.

Maybe I should say one more thing, a comment on the proceedings up to now: this occasion is a time when it is appropriate to exaggerate. It's impossible for me to exaggerate the feelings that I have, the feelings of gratitude for the opportunity to have participated in this forty years, which I think have been the most exciting, the most productive, and the most rewarding and the most fun period in the history of geophysics and geology. I feel extremely fortunate and extremely grateful to the people — Roger, Lyman Spitzer, many other people — who made this possible for me. Especially I think I am grateful to a number of people, some of whom are here tonight, some of them you've already heard from in the symposium this afternoon, who shared with me the often miserable work at sea and the joys of coming into port and beautiful places like Tonga, Samoa, Tahiti, Singapore. I'm very grateful to people like George Shor, Betty, Marilee Henry, Helen Kirk, Alan Jones, Arthur Raff, who was in the work from the very beginning — I can't possibly think of all the people with whom I've shared this marvelous experience. Thank you very much.

*Scripps Institution of Oceanography, San Diego, CA 92093

[Victor Vacquier then volunteered to speak]

Victor Vacquier*

I want to thank the organizers of this meeting — John Sclater and also the management of the Marine Physical Laboratory for this happy occasion. I would like to say a few words about how grateful I personally am to the U. S. Navy. I had been connected with the Navy way before I came to Scripps. Just shortly before the war came along I had to do one thing with the magnetometer and we had this submarine go back and forth. Later my superior Dr. [E. A.] Eckhardt at Gulf said, "Vic, you should put it on an airplane." I thought "Oh, my gosh, only an executive completely disconnected from real life could suggest a thing like that." Of course, we did put it on an airplane.

I came here to San Diego during the war, this was 1941 or 1942. We had a squadron of PBY's (VP63) equipped with magnetometers and we were chasing submarines not too far from the harbor. You know how it is: you fly like this and you get as close as possible to the submarine; when you maneuver, you have to rise before you can make a turn. Otherwise you would dig in your wing into the water. It was at that time that I got acquainted with [Raymond] Peterson.

Later on at Sperry Gyroscope I worked for the Bureau of Ships actually, and I made a million-dollar mistake — and they let us continue the work! A million dollars in those days was a lot of money. The mistake was: we had a gyroscopic system consisting of two gyroscopes and a bowl about 20 inches in diameter sucked into a prop by air and supported by other air jets on the side. So there was this air film about two or three-thousandths of an inch between you and disaster, and that was the mistake. So, of course it didn't work. But that did make the Mark 19, which to this day I understand is still working on the ships.

So I am very grateful to the Navy for the past and also for my association with the Marine Physical Laboratory which has its connection, of course, with the Navy and who have supported this work of ours at Scripps. So, to the Navy I think we ought to offer a vote of thanks.

It has been very pleasant to go to sea with everybody here, and, on the whole, I think going to sea is a happy experience.

*Scripps Institution of Oceanography, La Jolla, CA 92093

REPORT DOCUMENTATION PAGE

1a. REPORT SECURITY CLASSIFICATION Unclassified		1b. RESTRICTIVE MARKINGS	
2a. SECURITY CLASSIFICATION AUTHORITY		3. DISTRIBUTION / AVAILABILITY OF REPORT Approved for public release; distribution unlimited.	
2b. DECLASSIFICATION / DOWNGRADING SCHEDULE		5. MONITORING ORGANIZATION REPORT NUMBER(S)	
4. PERFORMING ORGANIZATION REPORT NUMBER(S) MPL-U-42/87		7a. NAME OF MONITORING ORGANIZATION OFFICE OF NAVAL RESEARCH	
6a. NAME OF PERFORMING ORGANIZATION MARINE PHYSICAL LABORATORY	6b. OFFICE SYMBOL (If applicable) MPL	7b. ADDRESS (City, State, and ZIP Code) Department of the Navy 800 North Quincy Street Arlington, Virginia 22217-5000	
6c. ADDRESS (City, State, and ZIP Code) University of California, San Diego Scripps Institution of Oceanography San Diego, California 92152		9. PROCUREMENT INSTRUMENT IDENTIFICATION NUMBER N00014-87-G-0052	
8a. NAME OF FUNDING / SPONSORING ORGANIZATION Office of Naval Research	8b. OFFICE SYMBOL (If applicable) ONR	10. SOURCE OF FUNDING NUMBERS	
8c. ADDRESS (City, State, and ZIP Code) Department of the Navy 800 North Quincy Street Arlington, Virginia 22217-5000		PROGRAM ELEMENT NO.	PROJECT NO.
11. TITLE (Include Security Classification) MARINE GEOPHYSICS: A NAVY SYMPOSIUM		TASK NO.	WORK UNIT ACCESSION NO.
12. PERSONAL AUTHOR(S) Edited by Elizabeth N. Shor and Carolyn L. Ebrahimi			
13a. TYPE OF REPORT Proceedings	13b. TIME COVERED FROM _____ TO _____	14. DATE OF REPORT (Year, Month, Day) September 1987	15. PAGE COUNT 102
16. SUPPLEMENTARY NOTATION			
17. COSATI CODES		18. SUBJECT TERMS (Continue on reverse if necessary and identify by block number)	
FIELD	GROUP	SUB-GROUP	
19. ABSTRACT (Continue on reverse if necessary and identify by block number)			
<p>(U) This book comprises the proceedings of a symposium held in honor of the 80th birthdays of Russell W. Raitt and Victor Vacquier and the 40th anniversary of the Marine Physical Laboratory of Scripps Institution of Oceanography of the University of California, San Diego. The proceedings which stands as a tribute, serves to preserve many of the talks given at the symposium and includes biographical sketches.</p>			
20. DISTRIBUTION / AVAILABILITY OF ABSTRACT <input type="checkbox"/> UNCLASSIFIED/UNLIMITED <input checked="" type="checkbox"/> SAME AS RPT. <input type="checkbox"/> DTIC USERS		21. ABSTRACT SECURITY CLASSIFICATION	
22a. NAME OF RESPONSIBLE INDIVIDUAL Carolyn L. Ebrahimi		22b. TELEPHONE (Include Area Code) (619) 534-1794	22c. OFFICE SYMBOL MPL