

Lawrence Berkeley National Laboratory

Recent Work

Title

ELLIPTICAL VACUUM CHAMBER STRESS AND DEFLECTIONS

Permalink

<https://escholarship.org/uc/item/1w8561v6>

Authors

Avery, Robert T.

Tidrick, Garry A.

Publication Date

1969-02-17

For National Particle Accelerator Conference,
Washington, D. C., March 5-7, 1969

UCRL-18553
Preprint

G. J.

ELLIPTICAL VACUUM CHAMBER STRESS AND DEFLECTIONS

RECEIVED
LAWRENCE
RADIATION LABORATORY

APR 7 1969

LIBRARY AND
DOCUMENTS SECTION

Robert T. Avery and Garry A. Tidrick

February 17, 1969

AEC Contract No. W-7405-eng-48

TWO-WEEK LOAN COPY

*This is a Library Circulating Copy
which may be borrowed for two weeks.
For a personal retention copy, call
Tech. Info. Division, Ext. 5545*

LAWRENCE RADIATION LABORATORY
UNIVERSITY of CALIFORNIA BERKELEY

UCRL-18553
G. J.

DISCLAIMER

This document was prepared as an account of work sponsored by the United States Government. While this document is believed to contain correct information, neither the United States Government nor any agency thereof, nor the Regents of the University of California, nor any of their employees, makes any warranty, express or implied, or assumes any legal responsibility for the accuracy, completeness, or usefulness of any information, apparatus, product, or process disclosed, or represents that its use would not infringe privately owned rights. Reference herein to any specific commercial product, process, or service by its trade name, trademark, manufacturer, or otherwise, does not necessarily constitute or imply its endorsement, recommendation, or favoring by the United States Government or any agency thereof, or the Regents of the University of California. The views and opinions of authors expressed herein do not necessarily state or reflect those of the United States Government or any agency thereof or the Regents of the University of California.

ELLIPTICAL VACUUM CHAMBER STRESS AND DEFLECTIONS*

Robert T. Avery and Garry A. Tidrick
Lawrence Radiation Laboratory
University of California
Berkeley, California

Summary

Equations are derived for the bending moments and stresses at all points and for deflections at the major and minor axes in a uniform-wall tubular chamber of elliptical cross section subjected to uniform pressure loading. Graphs are included to facilitate computations.

Introduction

A cross section of the elliptical chamber is shown in Fig. 1. Internal pressure is taken positive to agree with pressure vessel literature. Thus, p is negative for internal vacuum (external pressure). In the analysis, the following simplifying assumptions were made: (1) axial effects are neglected; (2) deflections are small and linear theory is used; (3) uniform pressure; (4) uniform wall thickness; (5) stability effects are not considered.

Bending Moments

Because of symmetry, only one quadrant of the ellipse needs to be considered. A free-body diagram and associated reactions for static equilibrium are shown in Fig. 2. Since the ellipse is statically indeterminate, the necessary additional equation is derived by noting that the slopes at the major and minor axes remain unchanged during the application of the load.

By the method of virtual work,¹ the moments (per unit length) at minor and major axes are derived as²

$$M_1 = (-pa^2/6) [-1+2k^2+(1-k^2)F/E] = -K_1 pa^2$$

$$M_2 = (pa^2/6) [1+k^2-(1-k^2)F/E] = K_2 pa^2,$$

where F and E are complete elliptic integrals of the first and second kind, and $k = [1-(b/a)^2]^{1/2}$. K_1 and K_2 are given as functions of b/a in Fig. 3.

From the free-body diagram (Fig. 2), the moment at any point along the ellipse is

$$M = M_1 + (pk^2x^2/2) = K_x pa^2,$$

where K_x is given as a function of x/a for selected values of b/a in Fig. 4.

*Work performed under auspices of U. S. Atomic Energy Commission.

Stresses

In a chamber with uniform wall thickness, the bending stress is $\sigma_m = \pm Mc/I = \pm 6M/t^2$, and the circumferential hoop stress is $\sigma_h = pb/\{t[1-k^2(x/a)^2]^{1/2}\}$. The total stress is the algebraic sum of these two. The maximum total stresses at the major and minor axes are:

$$|\sigma_2|_{\max} = |6K_2 pa^2/t^2| + |pa/t|$$

$$|\sigma_1|_{\max} = |6K_1 pa^2/t^2| + |pb/t|.$$

In many cases, the hoop stress is negligible compared to the bending stress. If the wall is thick, the stress distribution should be modified according to curved-beam theory.

Deflections

A virtual unit load, $w=1$, is applied at the minor axis. From the expression for the bending moment m due to this unit load and from the previously derived expression for the actual bending moment, the actual deflection is

$$\delta_y = \int_0^{s_0} \frac{Mm}{D} ds = \frac{pa^4}{D} \left[\frac{K_1}{2} + \frac{3k^2 - 1}{16} + \frac{b^2 (8K_1 + 1 + 3k^3)}{32 ka^2} \ln \left(\frac{1+k}{1-k} \right) \right] = \frac{C_1 pa^4}{D},$$

where D is the flexural rigidity of the wall. A similar analysis for a virtual unit load placed at the major axis gives

$$\delta_x = \frac{pa^4}{D} \left[K_1 \left(\frac{b^2}{2a^2} + \frac{b}{2ka} \arcsin k \right) - \frac{1-3k^2+2k^4}{16} + (b/16 ka) \arcsin k \right] = \frac{C_2 pa^4}{D}.$$

C_1 and C_2 are plotted as functions of b/a in Fig. 5. The foregoing virtual work methods can be extended for deflections at any point and for other chamber configurations, possibly using graphical or numerical integration.

References

1. A. S. Niles and J. S. Newell, Airplane Structures (John Wiley & Sons, Inc., N. Y., 1945), 3rd ed.
2. R. T. Avery and G. A. Tidrick, "Structural Analysis of an Elliptical Chamber with a Uniform Pressure Loading," UCID-3215, 1968.

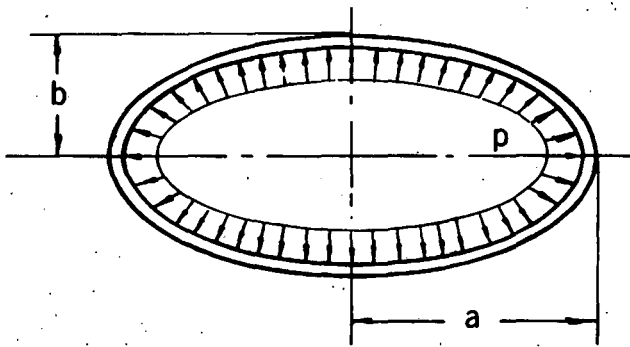

Fig. 1. Elliptical chamber cross section.

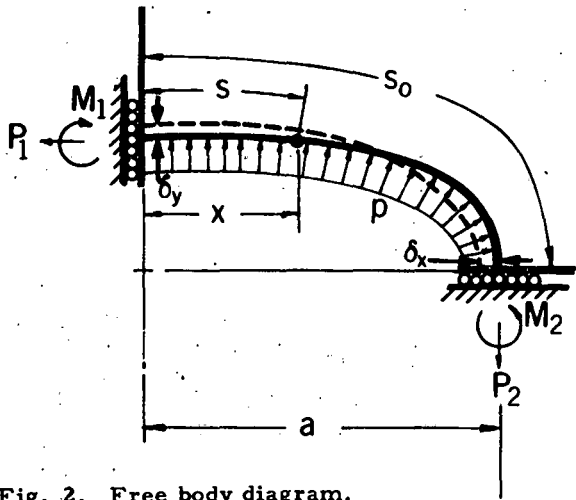

Fig. 2. Free body diagram.

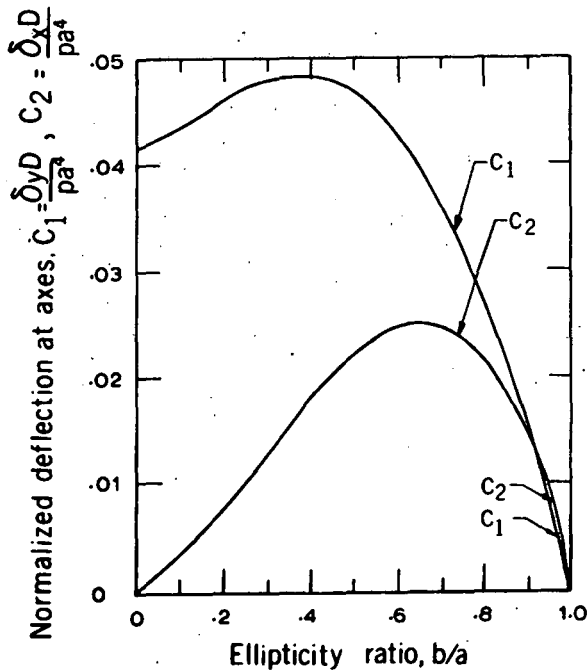

Fig. 3. Bending moments at principal axes.

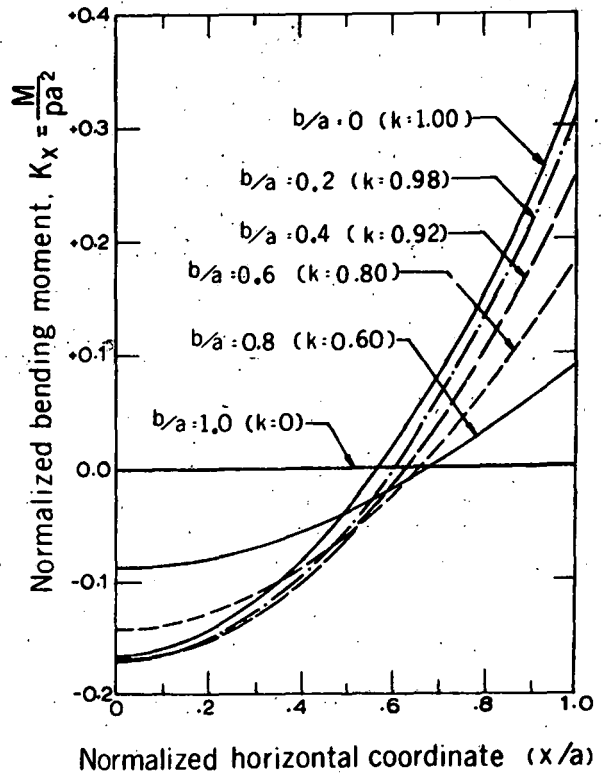

Fig. 4. Bending moments at intermediate points.

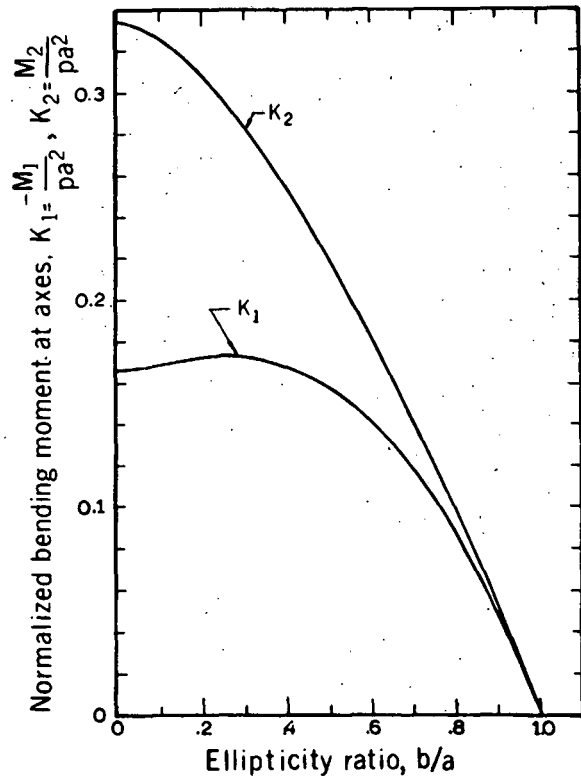

Fig. 5. Deflections at Principal Axes.

LEGAL NOTICE

This report was prepared as an account of Government sponsored work. Neither the United States, nor the Commission, nor any person acting on behalf of the Commission:

- A. Makes any warranty or representation, expressed or implied, with respect to the accuracy, completeness, or usefulness of the information contained in this report, or that the use of any information, apparatus, method, or process disclosed in this report may not infringe privately owned rights; or*
- B. Assumes any liabilities with respect to the use of, or for damages resulting from the use of any information, apparatus, method, or process disclosed in this report.*

As used in the above, "person acting on behalf of the Commission" includes any employee or contractor of the Commission, or employee of such contractor, to the extent that such employee or contractor of the Commission, or employee of such contractor prepares, disseminates, or provides access to, any information pursuant to his employment or contract with the Commission, or his employment with such contractor.

TECHNICAL INFORMATION DIVISION
LAWRENCE RADIATION LABORATORY
UNIVERSITY OF CALIFORNIA
BERKELEY, CALIFORNIA 94720