

# **Improving Construction Workflow- The Role of Production Planning and Control**

by

Farook Ramiz Hamzeh

MS (University of California at Berkeley) 2006

M Eng. (American University of Beirut) 2000

B Eng. (American University of Beirut) 1997

A dissertation submitted in partial satisfaction  
of the requirements for the degree of

Doctor of Philosophy

in

Engineering - Civil and Environmental Engineering

in the

GRADUATE DIVISION

of the

UNIVERSITY OF CALIFORNIA, BERKELEY

Committee in charge:

Professor Iris D. Tommelein (CEE), Chair

Professor Glenn Ballard (CEE)

Professor Phil Kaminsky (IEOR)

Fall 2009

# **Improving Construction Workflow- The Role of Production Planning and Control**

Copyright 2009

by

Farook Ramiz Hamzeh

## Abstract

Improving Construction Workflow- The Role of Production Planning and Control

by

Farook Ramiz Hamzeh

Doctor of Philosophy in Engineering - Civil and Environmental Engineering

University of California, Berkeley

Professor Iris D. Tommelein (CEE), Co-Chair, Professor Glenn Ballard (CEE), Co-Chair

The Last Planner™ System (LPS) has been implemented on construction projects to increase work flow reliability, a precondition for project performance against productivity and progress targets. The LPS encompasses four tiers of planning processes: master scheduling, phase scheduling, lookahead planning, and commitment / weekly work planning. This research highlights deficiencies in the current implementation of LPS including poor lookahead planning which results in poor linkage between weekly work plans and the master schedule. This poor linkage undermines the ability of the weekly work planning process to select for execution tasks that are critical to project success. As a result, percent plan complete (PPC) becomes a weak indicator of project progress.

The purpose of this research is to improve lookahead planning (the bridge between weekly work planning and master scheduling), improve PPC, and improve the selection of tasks that are critical to project success by increasing the link between

Should, Can, Will, and Did (components of the LPS), thereby rendering PPC a better indicator of project progress.

The research employs the case study research method to describe deficiencies in the current implementation of the LPS and suggest guidelines for a better application of LPS in general and lookahead planning in particular. It then introduces an analytical simulation model to analyze the lookahead planning process. This is done by examining the impact on PPC of increasing two lookahead planning performance metrics: tasks anticipated (TA) and tasks made ready (TMR). Finally, the research investigates the importance of the lookahead planning functions: identification and removal of constraints, task breakdown, and operations design.

The research findings confirm the positive impact of improving lookahead planning (i.e., TA and TMR) on PPC. It also recognizes the need to perform lookahead planning differently for three types of work involving different levels of uncertainty: stable work, medium uncertainty work, and highly emergent work.

The research confirms the LPS rules for practice and specifically the need to plan in greater detail as time gets closer to performing the work. It highlights the role of LPS as a production system that incorporates deliberate planning (predetermined and optimized) and situated planning (flexible and adaptive).

Finally, the research presents recommendations for production planning improvements in three areas: process related- (suggesting guidelines for practice), technical- (highlighting issues with current software programs and advocating the inclusion of collaborative planning capability), and organizational improvements (suggesting transitional steps when applying the LPS).

## ***ACKNOWLEDGMENTS***

Research is funded by membership contributions in support of the Project Production Systems Laboratory at UC Berkeley (<http://p2sl.berkeley.edu>). I am grateful for this assistance. The findings and views expressed in this study represent the author's and do not necessarily reflect the views of the Project Production Systems Laboratory.

I am indebted to my dissertation committee members: Professor Glenn Ballard for his support in developing the research direction and for being there when I needed help, Professor Iris Tommelein for her guidance in meticulous scientific research, and Professor Philip Kaminsky. Their guidance in shaping this dissertation, investing countless hours spent in research reviews, meetings, and ever-intriguing discussions, and facilitating field research, has been invaluable.

I would like to thank Mr. Greg Howell and Professor Tariq Abdelhamid for their help with the industry survey and Professor Lauri Koskela for his insightful comments and suggestions.

I am grateful for the industry research grants provided by Herrero-Boldt and Rudolph and Sletten for 2008-2009.

Thanks to all industry practitioners who provided significant help in field research: Andy Sparapani, Baris Lostuvali, Stephanie Rice, Paul Riser, Michelle Hoffmann, John Mack, Alia Elsmann, John Koga, Rob Purcel, and Scott Muxen at the Cathedral Hill Hospital Project; Charles Hernandez, Baris Lostuvali, John Biale, and Brad Krill at the CPMC Davies project; Michael Piotrkowski, Daniele Douthett, and

Lacey Walker at UCSF's Cardiovascular Research Center project; Igor Starkov from TOKMO; and Jan Elfving from Skanska, Finland. I am grateful for their contributions.

Special thanks to my "Agraphia" writing group colleagues: Zofia Rybkowski, Kofi Inkabi, Hung Nguyen, Long Nguyen, and Sebastien Humbert. Their efforts paid huge dividend in improving my academic writing. I would also like to thank my colleagues and office mates at 407 McLaughlin: Kristen Parrish and Nick Santero for their help when I needed it.

I am indebted to my friends Sara Al Beaini, Luke Harley, and Nazanin Shahrokni who volunteered to edit this manuscript at different stages of research.

*To my parents Samira and Ramez, my sister Pascale, and my brother Ghandi for  
all the sacrifices they have made.*

## ***TABLE OF CONTENTS***

ACKNOWLEDGMENTS .....	iii
TABLE OF CONTENTS.....	vi
LIST OF FIGURES .....	xiii
LIST OF TABLES .....	xviii
LIST OF FORMULAS .....	xix
LIST OF FORMULAS .....	xix
LIST OF ACRONYMS .....	xx
LIST OF DEFINITIONS .....	xxi
CHAPTER 1 - INTRODUCTION.....	1
1.1 Research Context .....	1
1.1.1 Background.....	1
1.1.2 Pilot Case Study.....	5
1.1.3 Survey Assessing Industry’s Planning Practices - the Last Planner System 10	
1.1.4 Findings from the Pilot Case Study and Industry.....	11
1.1.5 Research Motivation and Significance .....	13
1.2 Research Methodology .....	15
1.2.1 Research Goal and Objectives .....	16
1.2.2 Hypothesis.....	17
1.2.3 Research Questions.....	18
1.2.4 Research Scope and Focus.....	18
1.2.5 Research Design.....	20



1.2.6	Case Studies .....	22
1.2.7	Data Analysis .....	23
1.2.8	Validation of Results and Attaining Research Rigor .....	24
1.2.9	Research Limitations .....	25
1.2.10	Personal Motivation .....	26
1.3	Dissertation Structure.....	27
1.4	References.....	29
CHAPTER 2 - LITERATURE REVIEW.....		33
2.1	Background.....	33
2.1.1	The Supply Chain Management View .....	33
2.1.2	The Lean Construction View .....	35
2.2	Flow and Variability .....	38
2.2.1	Lean Flow .....	38
2.2.2	TFV Theory .....	39
2.2.3	Construction Flows .....	40
2.2.4	Uncertainty in Construction Flows .....	43
2.2.5	Variability in Systems.....	46
2.2.6	Variability and Waste in Construction Processes .....	47
2.2.7	Characterizing Flow Variability in Manufacturing.....	51
2.2.8	Buffers.....	53
2.2.9	Push-Pull Systems.....	55
2.3	Supply Chain Management and Logistics .....	57
2.3.1	Supply Chain Management.....	57

2.3.2	Logistics .....	57
2.3.3	Supply Chain Management versus Logistics .....	58
2.4	Waste.....	58
2.5	Planning and Scheduling in Uncertain Environments .....	59
2.6	References.....	62
<b>CHAPTER 3 - PRIMARY CASE STUDY - CATHEDRAL HILL HOSPITAL</b>		
	<b>PROJECT.....</b>	<b>68</b>
3.1	Project Background.....	68
3.1.1	Case Study Selection.....	68
3.1.2	Project Scope .....	69
3.1.3	Integrated Project Delivery Team.....	70
3.2	The Old Planning Process.....	72
3.2.1	Master Scheduling .....	72
3.2.2	Phase Scheduling .....	74
3.2.3	Lookahead Planning.....	75
3.2.4	Commitment / Weekly Work Planning.....	75
3.3	Critique of the Old Planning Process.....	76
3.3.1	Observations, Comments, and Suggestions for Improvement.....	76
3.3.1.1	Observations and Suggestions Initiating Process Adjustments.....	77
3.3.1.2	General Comments .....	78
3.3.2	Gap between Master Schedule and Weekly Work Plan .....	79
3.4	Designing the New Planning Process .....	83
3.4.1	Team Formation.....	83

3.4.2	Recommendations for Improving the Current Process.....	83
3.4.3	The New Planning Process .....	86
3.4.3.1	Process Map.....	87
3.4.3.2	Planning/Scheduling Development Plan .....	92
3.4.3.3	Information flow.....	95
3.5	Implementing the New Planning Process .....	98
3.5.1	Training.....	98
3.5.2	Start-up.....	99
3.6	Implementation Challenges .....	99
3.6.1.1	Local Factors .....	100
3.6.1.2	General Factors.....	100
3.7	Summary and Conclusions .....	102
3.8	References.....	104
CHAPTER 4 - SUPPORTING CASE STUDIES- FAIRFIELD MEDICAL OFFICE		
BUILDING, THE RETREAT AT FORT BAKER, AND UCSF’S CARDIOVASCULAR		
RESEARCH CENTER.....		
4.1	Fairfield Medical Office Building .....	108
4.1.1	Background.....	108
4.1.2	Long-Term and Short-Term Planning Processes.....	108
4.1.3	Conclusions.....	112
4.2	The Retreat at Fort Baker.....	113
4.2.1	Background.....	113
4.2.2	Long-Term and Short-Term Planning Processes.....	114

4.2.3	Conclusions.....	119
4.3	UCSF’s Cardiovascular Research Center .....	119
4.3.1	Background.....	119
4.3.2	Implementing the Last Planner™ System .....	120
4.3.3	Conclusions and Process Critique.....	123
4.4	Cross Case Comparison .....	<b>Error! Bookmark not defined.</b>
4.5	References.....	125
CHAPTER 5 - SUGGESTED FRAMEWORK FOR PRODUCTION PLANNING		
AND CONTROL.....		
		126
5.1	Why the Last Planner™ System?.....	126
5.2	Overview of the Last Planner™ System.....	128
5.3	Work Structuring and Schedule Development .....	130
5.4	The Last Planner Process .....	137
5.4.1	Master Scheduling .....	137
5.4.2	Phase Scheduling .....	139
5.4.3	Lookahead Planning.....	144
5.4.3.1	Tasks Anticipated and Tasks Made Ready.....	150
5.4.3.2	Constraints Analysis .....	152
5.4.4	Weekly Work Planning.....	154
5.4.4.1	Reliable Promising .....	157
5.4.4.2	Learning.....	157
5.5	Conclusions.....	163
CHAPTER 6 - SIMULATION MODEL FOR LOOKAHEAD PLANNING.....		
168		

6.1	Background.....	168
6.2	Simulation Model.....	170
6.2.1	Conceptual Model Design.....	170
6.2.1.1	Context within the LPS.....	170
6.2.1.2	Model Design .....	171
6.2.2	Mathematical Notation.....	181
6.2.2.1	Definitions of Variables and Parameters .....	181
6.2.2.2	Model Assumptions.....	183
6.2.2.3	Definitions and Calculation of Metrics .....	185
6.2.3	Experimental Simulations.....	187
6.2.3.1	R and RR .....	187
6.2.3.2	P and NR.....	193
6.2.3.3	New and N.....	196
6.2.3.4	TA and PPC.....	198
6.2.3.5	TMR and PPC.....	202
6.3	Summary of Simulation Results and Conclusions.....	206
6.4	References.....	210
	CHAPTER 7 - CONCLUSIONS AND RECOMMENDATIONS.....	211
7.1	Observations, Conclusions, and Recommendations.....	212
7.1.1	Process-Related Observations, Conclusions, and Recommendations .....	213
7.1.1.1	Observations .....	213
7.1.1.2	Conclusions .....	214
7.1.1.3	Recommendations .....	217

7.1.2	Technical Observations, Conclusions, and Recommendations .....	218
7.1.2.1	Observations .....	218
7.1.2.2	Conclusions .....	219
7.1.2.3	Recommendations .....	219
7.1.3	Organizational Observations, Conclusions, and Recommendations .....	219
7.1.3.1	Observations .....	219
7.1.3.2	Conclusions .....	220
7.1.3.3	Recommendations .....	221
7.2	Research Findings.....	222
7.3	Contributions to Knowledge.....	225
7.3.1	Contributions of the Supporting Case Studies .....	226
7.3.2	Contributions of the Primary Case.....	226
7.3.3	Contributions of the Framework for Implementing the Last Planner System 227	
7.3.4	Contributions of the Simulation Experiments.....	228
7.4	Further Research .....	228
7.5	References.....	230
	APPENDIX - INDUSTRY SURVEY RESULTS .....	232
	REFERENCES .....	237

## ***LIST OF FIGURES***

Figure 1.1: Buffers in a production system to cater for uncertainty in input flows.....3 (after Hamzeh et al. 2008, adjusted from Koskela 2000, Ballard et al. 2003, and Bertelsen et al. 2006) .....	3
Figure 1.2: Percent Plan Complete (PPC) tracked over time.....7	7
Figure 1.3: Temporal count of weekly open constraints.....8	8
Figure 1.4: Age of open constraints for the week of 10/23/07. ....9	9
Figure 1.5: Survey results showing the percentage of organizations addressing plan failures on the weekly work plan. ....11	11
Figure 1.6: The relationship between productivity and implementing the LPS (Alarcon and Cruz 1997).....14	14
Figure 1.7: Scatter plot and linear regression between productivity and PPC (Liu and Ballard 2008). ....14	14
Figure 1.8: Layout of the research process. ....16	16
Figure 1.9: Research scope within the LPDS system (Ballard 2006).....19	19
Figure 1.10: Case study research design (modified after Yin 2003). ....23	23
Figure 1.11: Dissertation structure.....28	28
Figure 2.1: Flows involved in a construction activity; after Koskela (2000). ....41	41
Figure 2.2: Effect of synchronized flow on successor activities. ....44	44
Figure 2.3: Task realization versus certainty in 1-7 input flows.....45	45
Figure 2.4: Flow of process and operations (Shingo 1988).....46	46
Figure 2.5: Supply-Demand mismatch. ....47	47
Figure 2.6: Flow variability between stations (after Hopp and Spearman 2008). ....51	51

Figure 3.1: The relationship between percentage of work not complete (1-PPC) and incremental schedule difference .....	81
Figure 3.2: Scheduling stability performance comparing normalized schedule variance with PPC .....	82
Figure 3.3: Process map depicting the planning process at CHH project (Modified from The Last Planner Handbook at CHH project, 2009).....	88
Figure 3.4: Reverse phase schedule exceeding limit limits (Ballard 2008).....	90
Figure 3.5: Overview of planning processes in the LPS at CHH project (The Last Planner Handbook at CHH project, 2009).....	92
Figure 3.6: The LPS scheduling development model at CHH project .....	93
Figure 3.7: Filtering and feedback between the master schedule and cluster lookahead plan (The Last Planner Handbook at CHH project, 2009).....	94
Figure 3.8: Information flow between team planners at CHH project (The Last Planner Handbook at CHH project, 2009).....	96
Figure 3.9: Information flow model for planning processes at CHH project (Modified from The Last Planner Handbook at CHH project, 2009).....	97
Figure 4.1: Incremental schedule difference for seven different milestone stages at Fairfield Medical Office Building .....	110
Figure 4.2: Standard deviation of schedule difference for each milestone from original planned date .....	111
Figure 4.3: Percent Plan Complete (PPC) figures for a portion of the project. ....	112
Figure 4.4: The relationship between percentage of work not complete (1-PPC) and incremental schedule difference for building ‘601’ .....	116



Figure 4.5: The relationship between percentage of work not complete (1-PPC) and incremental schedule difference for building ‘602’ .....	117
Figure 4.6: Project costs incurred by month on the rehabilitation section of the Fort Baker Retreat Project.....	118
Figure 4.7: Implementing the LPS on UCSF’s CVRC .....	122
Figure 4.8: Weekly planning steps on CVRC.....	123
Figure 5.2: Planning stages/levels in the Last Planner™ system for production planning and control .....	129
(Adjusted from Ballard 2000a).....	129
Figure 5.3: The Last Planner™ System (adopted from Ballard and Hamzeh 2007).....	131
Figure 5.4: Work structuring within Lean Project Delivery System (Ballard 2006).....	133
Figure 5.5: Schedule development and work structuring in LPS. ....	135
Figure 5.6: Breaking down tasks to the level of operations and steps (after Ballard 2000a)	136
Figure 5.7: The master scheduling process in the LPS.....	138
Figure 5.8: The phase scheduling process in the LPS .....	140
Figure 5.9: Reverse phase schedule exceeding limit limits (Ballard 2008).....	142
Figure 5.10: Reverse phase schedule adjusted to create a schedule buffer (Ballard 2008)	143
Figure 5.11: Reverse phase schedule after schedule buffer has been distributed (Ballard 2008).....	144
Figure 5.12: The lookahead planning process in the LPS .....	146
Figure 5.13: Six-week lookahead planning process (Hamzeh et al. 2008).....	148
Figure 5.14: Measuring tasks anticipated (TA), tasks made ready (TMR), and percent plan complete (PPC). ....	151

Figure 5.15: Gross and specific constraints .....	153
Figure 5.16: The weekly work planning process in the LPS .....	155
Figure 5.17: Sample of root cause analysis using the weekly work plan. ....	159
Figure 5.18: An Example exercise for root cause analysis.....	161
Figure 5.19: Example process for learning from plan failures employing built-in quality	163
Figure 6.1: The planning cycle using LPS.....	170
Figure 6.2: The lookahead planning process in the LPS. ....	172
Figure 6.3: Graphical process layout for lookahead planning from three weeks ahead of execution to execution week.....	174
Figure 6.4: Simulation model for lookahead planning .....	175
Figure 6.5: The lookahead planning process simulated over a three-week period. ....	179
Figure 6.6: Snapshot of the model in Excel.....	180
Figure 6.7: Calculating TA and TMR (2, 0). ....	188
Figure 6.8: The three possible paths to increasing PPC.....	189
Figure 6.9: Simulation results for Experiment 1 showing the relationship between R, RR, and PPC using deterministic variables.....	190
Figure 6.10: Results from Experiment 2 showing the relationship between R, NR, and PPC. ....	193
Figure 6.11: Results from Experiment 3 showing the relationship between P, NR, and PPC. ....	194
Figure 6.12: Results from Experiment 4 showing the relationship between NTP, N and PPC. ....	196

Figure 6.13: Results from Experiment 5 showing the relationship between New, N, and PPC. ....	198
Figure 6.14: Results from Experiment 6 showing the relationship between TA, R, P, and PPC. ....	200
Figure 6.14: Results from Experiment 7 showing the relationship between TA, RR, NR and PPC.....	201
Figure 6.16: Results from Experiment 8 showing the relationship between TMR, R, RR and PPC.....	203
Figure 6.17: Results from Experiment 9 showing the relationship between TMR, P, NR and PPC.....	204
Figure 6.18: Results from Experiment 10 showing the relationship between TMR, RR, NR and PPC. ....	206
Figure 7.1: The cone of uncertainty in software projects (McConnell 2008).....	216
Figure 7.2: The planning cycle using the LPS.....	229

## ***LIST OF TABLES***

Table 1.1: Status of constraints for the week of 10/23/07 .....	9
Table 1.2: Research tools employed to answer research questions .....	22
Table 2.1: Classification of flow variability (after Hopp and Spearman 2008).....	52
Table 3.1: Project stakeholders participating in the design validation study.....	73
Table 3.2: Observations and suggestions for improvement.....	78
Table 3.3: General observations and guidelines for application.....	79
Table 6.1: Variables and Parameters for Experiment 1 - Deterministic: R, RR, and PPC.	190
Table 6.2: Variables and Parameters for Experiment 2 - Deterministic: R, NR and PPC.	192
Table 6.3: Variables and Parameters for Experiment 3 - Deterministic: P, NR, and PPC.	194
Table 6.4: Variables and Parameters for Experiment 4 - Deterministic: P, NR, RR, and PPC. ....	195
Table 6.5: Variables and Parameters for Experiment 5 - Deterministic: New, N and PPC.	197
Table 6.6: Variables and Parameters for Experiment 6 - Deterministic: TA, R, P, and PPC. ....	199
Table 6.7: Variables and Parameters for Experiment 7- Deterministic: TA, RR, NR and PPC. ....	201
Table 6.8: Variables and Parameters for Experiment 8 - Deterministic: TMR, R, RR and PPC. ....	203
Table 6.9: Variables and Parameters for Experiment 9 - Deterministic: TMR, P, NR and PPC. ....	204
Table 6.10: Variables and Parameters for Experiment 10 - Deterministic: TMR, RR, NR and PPC.....	205

## ***LIST OF FORMULAS***

PPC = [Ready * RR + NotReadyCMR * NR + New * N] / [Ready * RR + NotReadyCMR * NR + New * N] + [Ready * (1-RR) + NotReadyCMR *(1- NR) + New *(1- N) ] (1).....	185
PPC = [TP(i) * R * RR + TP(i) * (1-R)* P * NR + New * N] / [ TP(i) *R * RR + TP(i) *(1-R)* P * NR + New * N] + [TP(i) *R * (1-RR) + TP(i) * (1-R)* P *(1- NR) + New *(1- N)] (2).....	185
PPC = TP(i) * [R * RR + (1-R)* P * NR + New / TP(i) * N] / TP(i) * [R * RR + (1-R)* P * NR + New / TP(i) * N + R * (1-RR) + (1-R)* P *(1- NR) + New / TP(i) *(1- N)] (3).....	185
PPC = [R * RR + (1-R)* P * NR + NTP * N] / [R * RR + (1-R)* P * NR + NTP * N] + [R * (1-RR) + (1-R)* P *(1- NR) + NTP *(1- N)] (4).....	185
TA = [TP(i) – TP(i-1) * (1-R) * (1-P)] / [TP(i) – TP(i-1) * (1-R) * (1-P) + New] (5)...	186
TA = [TP(i) (1 – [TP(i-1) / TP(i)] * (1-R)*(1-P)] / [TP(i) (1 – [TP(i-1)/TP(i)]* (1-R)*(1-P) + New / TP] (6) .....	186
TA = (1 - [TP(i-1) / TP(i)] * (1-R)*(1-P)] / [ (1 - [TP(i-1) / TP(i)] * (1-R)*(1-P) + NTP] (7).....	186
TMR (2, 0) = (Ready * RR + NotReadyCMR * NR) / TP (i) (8).....	186
TMR (2, 0) = (TP(i) * R * RR +TP(i) * (1-R) * P * NR) / TP(i) (9) .....	186
TMR (2, 0) = R * RR + (1-R) * P * NR (10).....	186
TMR (2, 1) = Ready / TP(i) = R * TP(i) / TP(i) = R (11).....	187
TMR (1, 0) = Done / (Done + NotDone)= PPC (12).....	187

## ***LIST OF ACRONYMS***

Acronyms	Stands for
AEC	Architecture, Engineering and Construction
BIM	Building Information Modeling
CHH	Cathedral Hill Hospital
CPM	Critical Path Method
IFOA	Integrated Form of Agreement
IGLC	International Group for Lean Construction
IPD	Integrated Project Delivery
JIT	Just-In-Time
LOB	Line of Balance
LPDS	Lean Project Delivery System
MRP	Material Requirement Planning
OSHPD	Office Statewide Health Planning and Development
PDCA	Plan-Do-Check-Act
PPR	Phased Plan Review
RFI	Request For Information
SCM	Supply Chain Management
SMED	Single Minute Exchange of Dies
TA	Tasks Anticipated
TFV	Transformation, Flow, Value
TMR	Tasks Made Ready
TPS	Toyota Production System
VSM	Value Stream Mapping
WIP	Work-In-Process

## ***LIST OF DEFINITIONS***

The following is a list of definitions for some terms used in this research:

*Integrated Project Delivery (IPD)*: It is a project delivery approach integrating human capital, systems, business structures, and process to align stakeholder interests, improve project performance, share risks and rewards, and maximize value for designers, builders, owner, and users through all phases of design, procurement, assembly, and construction (Lichtig 2005 and 2006, AIA California Council 2007).

*Lean Construction*: It is a philosophy of business management applied to production. It is expressed as an ideal to be pursued, principles to be followed in pursuit of the philosophy ideals, and methods to be employed in application of the principles (Ballard et al. 2007).

*Last Planner<sup>TM</sup> System (LPS)*: It is a production planning and control system implemented on construction projects to improve planning and production performance. The system comprises four main planning processes: (1) master scheduling, (2) phase scheduling, (3) lookahead planning, and (4) weekly work planning (Ballard and Howell 1994, Alarcon 1997, Tommelein and Ballard 1997, Ballard and Howell 2004, Ballard et al. 2007, Gonzalez et al. 2008).

*Master Scheduling*: It is the first step in front-end planning and involves developing logistics plans and work strategies prior to setting project milestones.

*Phase / Pull Scheduling*: It builds on the milestones set in master scheduling to define milestone deliverables, breakdown milestones into constituent activities, perform

collaborative reverse phase scheduling, and adjust the schedule to meet the available time frame.

*Lookahead Planning:* It is the first step in production planning. It starts by taking a lookahead filter from the phase schedule then breaking processes into operations, identifying and removing constraints, and designing operations (with the use of first run studies) (Ballard 1997, Hamzeh et al. 2008).

*Weekly Work Planning:* It drives the production process by developing reliable weekly work plans and initiates preparations to perform work as planned. Plan reliability at the weekly work planning level is promoted by making only quality assignments and reliable promises to shield production units from variability in upstream tasks. Percent plan complete (PPC), a metric used to track the performance of reliable promising, measures the percentage of tasks completed relative to those planned. Analyzing reasons for plan failures and acting on these reasons is the basis of learning (Ballard 2000a).

*Reliable Promising:* It is the process of requesting, clarifying / negotiating, making commitments, and executing commitments.

*Supply Chain:* It is a network of companies exchanging materials, services, information and funds with each other to satisfy end user needs.

*Supply Chain Management (SCM):* It is: (a) a collaborative relationship between supply chain firms pursuing global optimization goals by joint planning, management, implementation and control of operations; (b) an interdependence among firms requiring holistic analysis of tradeoffs shaping the performance of the whole chain; and (c) a quest towards customer satisfaction that translates into benefits for the whole network (Bowersox et al. 2007, Ayers 2006, Tommelein et al. 2003, and Simchi-Levi et al. 2003).



*Logistics* : By moving materials, services, funds, and information up and down the supply chain, 'logistics' ensures delivery of the right products and services in the right quantities to the right customers at the right time while minimizing costs. Some of the key logistics functions are: managing customer service, orders, inventory, transportation, storage, handling, packaging, information, forecasting, production planning, purchasing, cross docking, repackaging, preassembly, facility location and distribution (Christopher 1998, Simchi-Levi et al. 2003, Gourdin 2006, Bowersox et al. 2007, and Hamzeh et al. 2007).

# ***CHAPTER 1 - INTRODUCTION***

This chapter serves as a blueprint for the dissertation, highlighting its theoretical direction, scope, significance, research methodology, and research questions. The chapter is divided into two sections. The first section, Research Context, presents a background of the study and outlines the significance of the study. It is intended to answer the following questions: “What is this research about?” and “Why is this research worth pursuing and knowing?” Thus it identifies the research problem and sheds light on the added value of pursuing this research to construction knowledge and practice.

The second section, Research Methodology, describes the research methodology followed in this study by answering the question, “How is the research conducted?” It starts by stating research goals and objectives, then presents research questions, and concludes with the research methods employed to accomplish the stated goals and objectives. The chapter also presents the structure of the dissertation, outlining the logical path from introduction to conclusion.

## **1.1 Research Context**

### ***1.1.1 Background***

Variability, a characteristic of non-uniformity or unevenness, is ubiquitous in the Architecture, Engineering, and Construction (AEC) processes. It undermines project performance, disrupts workflow, and leaves detrimental project consequences on cost, duration, and quality (Crichton 1966, Nahmias 2009, Hamzeh et al. 2007). While there are many forms of variability, Hopp and Spearman (1996, 2008) underline two types as

per queuing theory: (1) process time for task execution at a workstation and (2) rate of task arrivals to the workstation. Variability exact a penalty on the performance of a production system in terms of lost production throughput, wasted capacity, increased cycle times, high levels of inventory, long lead times, poor quality, and unhappy customers (Hopp and Spearman 1996, Hopp and Spearman 2008, Tommelein and Weissenberger 1999, Tommelein 2003, and Alves 2005).

Organizations use different techniques to deal with variability. Thompson (1967) highlighted four main methods: (1) forecasting, (2) buffering, (3) smoothing, and (4) rationing. Forecasting is useful in anticipating variability in business processes. However, forecasts have many limitations including: the more specific a forecast is, the more the actual deviates from the forecast; the farther a forecast looks into the future, the less accurate it becomes; and forecasts are always wrong (Nahmias 2009).

Buffering is a method used to protect production from the harmful consequences of variability. Buffers of different types including time, capacity, and inventory are utilized as cushions, padding activities against variability and disruptions. Buffers can be used to absorb variability in both task inputs and task performance. Figure 1.1 shows an example of applying buffers to inputs for a construction task. Inputs typically needed for a successful execution of tasks include: information, previous work, human resources, space, material, equipment, external conditions, and funds (Koskela 2000, Ballard et al. 2003).

While buffers are useful against variability to cater for uncertainty, they are costly to apply, may cause complacency in organizations, and may lead to suboptimal

performance. This is one reason why lean practitioners advocate “lowering the river to reveal the rocks” (Ohno 1988).

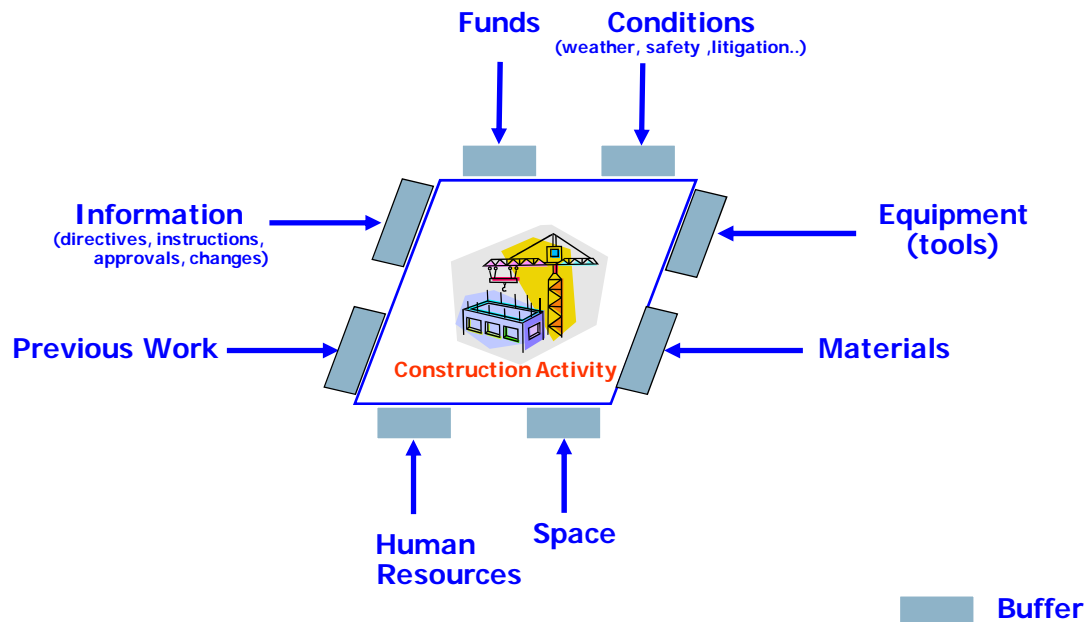

Figure 1.1: Buffers in a production system to cater for uncertainty in input flows

(after Hamzeh et al. 2008, adjusted from Koskela 2000, Ballard et al. 2003, and Bertelsen et al. 2006)

Smoothing is used to reduce variability. Rather than just living with the current system variability and investing in huge system buffers, an improvement that some organizations prefer is smoothing or reducing variability in inputs and internal operations. An example of smoothing is leveling work load or *heijunka* as advocated in the Toyota Production System (Liker 2004).

Last, rationing is limiting the allocation of resources to uncertain activities. When the previously mentioned techniques fail to reduce variability, organizations try to shield work processes by restricting the allocation of resources to uncertain tasks, i.e., implementing what is called production “rationing” (Thompson 1967).

The traditional approach to managing production in the construction industry emphasizes the use of project controls to reduce variances from schedules and budgets,

creates a contract-minded culture, and advances a push-based culture. Some of the consequences of this approach are claims and changes, budget overruns, schedule overruns, compromised quality, and safety issues. This adds to other issues faced in the construction industry including: myopic view of project parties, high levels of waste in various forms, low levels of trust, lack of communication and transparency, low customer satisfaction, and most importantly high variability (Vrijhoef and Koskela 2000, Hopp and Spearman 1996, Hopp and Spearman 2008, Green et al. 2005).

Challenging the traditional approach to construction, lean construction advocates collaborative production planning and execution. It emphasizes workflow reliability, maximizing value for the customer, and minimizing waste (Howell and Ballard 1998).

One of the main research streams in lean construction, that focuses on reducing the negative impacts of variability and increasing reliability of workflow, has led to the development of the Last Planner<sup>TM</sup> System (LPS) for production planning and control. This system has been successfully implemented on construction projects to improve planning and production performance (Ballard and Howell 1994, Alarcon 1997, Tommelein and Ballard 1997, Ballard and Howell 2004, Ballard et al. 2007, Gonzalez et al. 2008).

Responding to the challenges and deficiencies of traditional production planning and control in construction, the LPS embodies the following planning practices: (1) planning in greater detail as you get closer to performing the work, (2) developing the work plan with those who are going to perform the work, (3) identifying and removing work constraints ahead of time, as a team, in order to make work ready and increase reliability of work plans, (4) making reliable promises and driving work execution based

on coordination and active negotiation with trade partners and project parties, and (5) learning from planning failures by finding the root causes and taking preventive actions (Ballard et al. (1999a,1999b), Ballard 2000a, Ballard and Hamzeh 2007, Ballard et al. 2009).

Previous research has underlined the positive impact the LPS has on workflow variation and labor productivity. Secondary impacts may include improvements in work safety and quality (Ballard and Howell 1994, Alarcon and Cruz 1997, Ballard and Howell 1998, Ballard et al. 2007, Liu and Ballard 2008). While many of these previously mentioned studies focus on the positive outcomes of the LPS, an assessment of the current implementation of the LPS is needed to evaluate performance and suggest improvements. The first step I took in assessing performance was through a pilot case study and an industry survey which are discussed next.

### ***1.1.2 Pilot Case Study***

I have selected a pilot case study to investigate current planning processes in general and the application of the LPS in particular. The case study is a hospital rehabilitation project in San Francisco, California. The project is selected because the parties are lean-oriented, implementing collaborative processes, and employing the LPS for production planning and control. Moreover, the team is adopting lean practices including: collaboration, building networks of commitment, increasing relatedness, learning by doing, and optimizing the whole rather than the parts.

The goals of this case study are to examine and evaluate: (1) the weekly work planning process, (2) the relation between long-term planning and production planning,

and (3) the intermediate planning process (lookahead planning) including constraint analysis and removal.

The study examines the quality of (1) weekly work planning, (2) master scheduling, and (3) lookahead planning. While master scheduling sets project goals and milestones, lookahead planning focuses the team's attention on activities that need to be performed over the upcoming weeks. It helps in identifying constraints to be removed and prerequisites to be made ready. Weekly work planning drives production and develops weekly work plans (the most detailed plans in the LPS system). Weekly work planning helps in producing a more reliable workflow by making only quality assignments and exercising reliable promises. This reliability is gauged by measuring Percent Plan Complete (PPC), representing the ratio of tasks completed to those planned (Ballard 1997, Ballard 2000a, Ballard 2000c).

(1) The weekly work planning study involves tracking PPC, monitoring variance from planned work, and exploring methods to avoid plan failures. Figure 1.2 shows the PPC over 10 months in this pilot study. Although the PPC calculated for the tracked period was high (93%), the project suffered major delays and schedule overruns. This may seem strange and raises questions regarding the weekly work planning process. On a weekly basis, the project team monitored weekly work plans and highlighted reasons for plan variance or 'variance categories' (i.e. apparent reason for failure to complete a task as planned). While tracking these variance categories was useful in understanding plan failures, the lack of analyses to identify the root causes of failures reduced made it less likely to develop improvement methods and to take preventive actions to avoid the recurrence of failures.

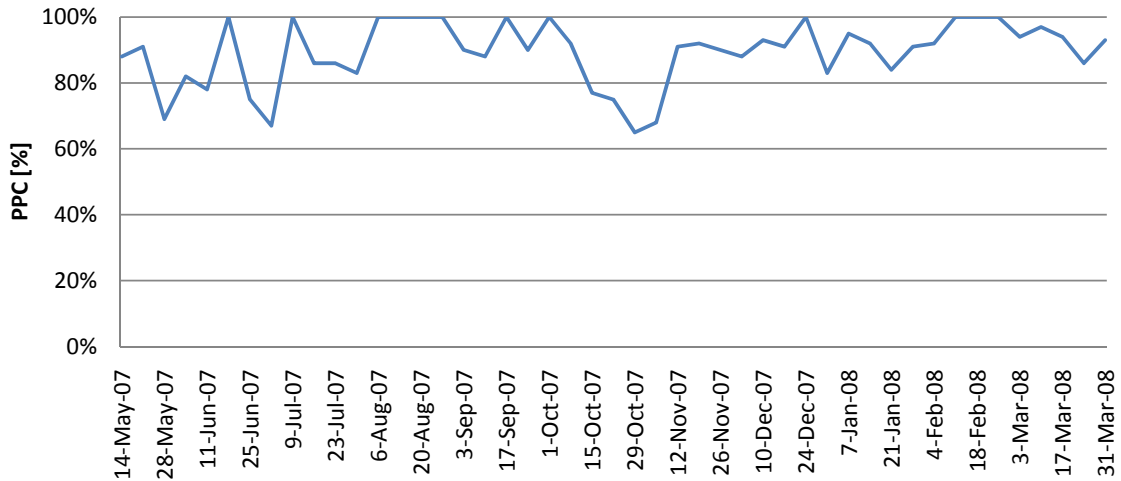

Figure 1.2: Percent Plan Complete (PPC) tracked over time.

(2) The master schedule study is intended to analyze the master-schedule development process and the relation between the master schedule and weekly work plans. In this pilot case study, the general contractor built the master schedule in Primavera P5 and P6 and built the weekly work plans in Microsoft Excel. The general contractor developed the master schedule incorporating owner-required milestones and input from major subcontractors. However, this schedule is a product of white collar construction engineers with limited input from blue collar representatives.

(3) The lookahead planning study examines the quality of lookahead planning in making work ready and removing constraints. Lookahead planning helps increase the window of planning reliability by looking at constraints prior to task execution, and resolving those having lead times beyond the weekly work plan window. Extending planning beyond the working week is beneficial in coordinating input from other parties such as deliveries by suppliers, information from the architect, or decisions from the owner.

The project team on this pilot project developed Lookahead plans by presenting a near-term view of tasks on the master schedule without necessarily designing operations



and running a formal constraint analysis study. The constraint analysis study normally involves constraint identification and constraint removal. Constraint identification is intended to measure the amount of time a constraint is recognized ahead of the task execution time. It gives an indication of the team’s capability to plan ahead and uncover constraints early on. Constraint removal addresses the process of prioritizing constraints and the way constraints are handled.

Figure 1.3 shows a weekly count of constraints on the pilot project for a 52-week period collected from the weekly constraints log. The project team developed this log, updated it weekly, and discussed it in weekly work plan meetings. Figure 1.3 shows constraints that hold up the progress of an activity in a certain area. Constraints may cause out of sequence work and suboptimal productivity especially when work crews start a subsection of a constrained activity while waiting for the constraint to be removed.

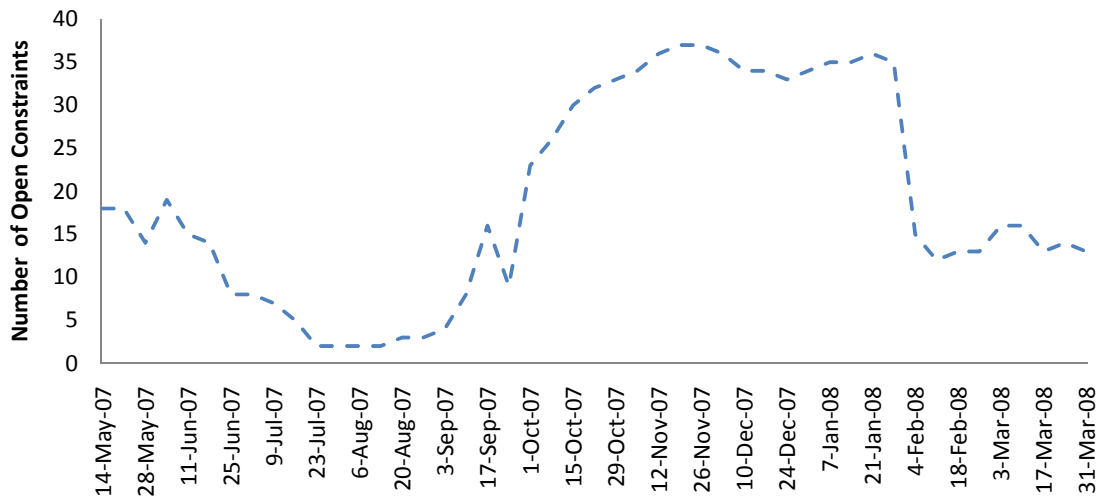

Figure 1.3: Temporal count of weekly open constraints.

An in-depth study for the week of 10/23/07 revealed 21 open constraints. Figure 1.4 shows the age or duration of each open constraint. This age has an average of 17 calendar days for each open constraint, which indicates that, on average, constraints are removed

within 2.5 weeks. However, the graph shows that some constraints take much longer (e.g., up to 77 calendar days) to get removed.

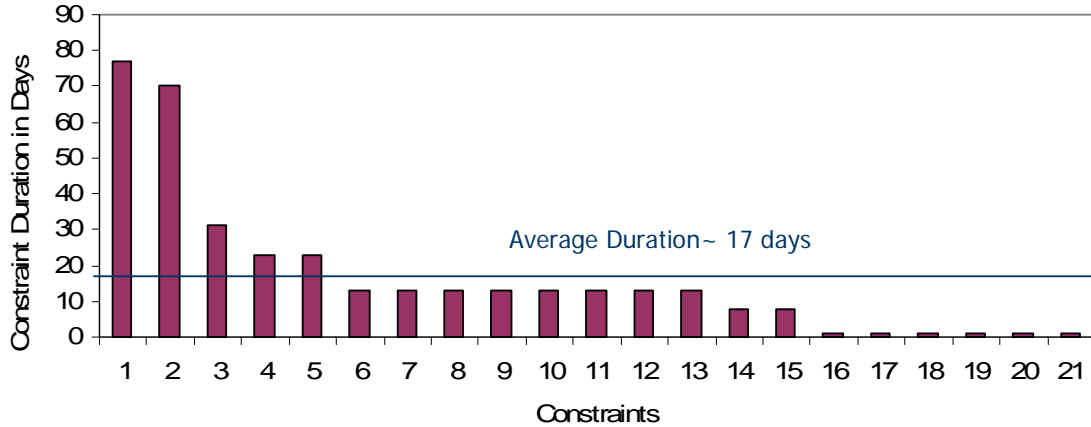

Figure 1.4: Age of open constraints for the week of 10/23/07.

Investigating the status of constraint removal, table 1.1 shows the status of constraints for week 10/23/07. Out of the 21 open constraints only 13 had been scheduled for action and given a due date. However, 12 due dates out of the 13 scheduled had not been respected, indicating failure to deliver at the promised date. These results indicate that poor performance in removing constraints can occur while having a high PPC.

Table 1.1: Status of constraints for the week of 10/23/07

Category	Count
Number of open constraints	21
Number of open constraints with promised due date	13
Number of open constraints surpassing promised date	12
Number of constraints closed this week	1
Number of constraints closed earlier	9

In summary, results from the pilot case study indicate inadequate implementation of the LPS. The findings are incorporated under section 1.1.4.

### ***1.1.3 Survey Assessing Industry's Planning Practices - the Last Planner System***

To better describe current planning practices and the implementation of the LPS, a survey was conducted in collaboration with the Lean Construction Institute (LCI) among LPS users inside and outside the US. The survey aimed at assessing the current implementation of the LPS, informing research on obstacles faced in the current practice, and providing input for forming improvement recommendations.

The survey addressed LPS users in the Americas and Europe occupying various project positions including owners, contractors, designers, consultants, construction managers, and specialty contractors. The survey was sent out to industry practitioners through several venues, including an open invitation through the LCI website (<http://www.leanconstruction.org>) and a direct request to a network of practitioners recommended by Professor Glenn Ballard at UC Berkeley, Professor Tariq Abdelhamid at Michigan State University, and Mr. Greg Howell at Lean Project Consulting.

The survey explores the following issues: (1) performance of the planning process during the four stages of the LPS (master scheduling, phase scheduling, lookahead planning, and weekly work planning), (2) organizational setup of the lookahead process, (3) planning and scheduling methods used in developing the lookahead plan, (4) software programs used to develop schedules at the various levels of the planning system, (5) the process of identifying and removing constraints, (6) the compatibility between the lookahead plan and the weekly work plan, and (7) methods employed for acting on reasons for plan failures.

The survey results helped draw a picture of the methods that the LPS users follow for planning and scheduling. The survey exposed performance issues and areas for

improvement. To illustrate, Figure 1.5 shows that most industry practitioners track only categories of plan failures (e.g., sequence and materials) but do not necessarily perform analysis to uncover root causes and take preventive actions that inhibit the recurrence of such failures. Complete results from the survey summarizing feedback from 133 returned surveys can be found in the appendix. The next section highlights some of the survey findings.

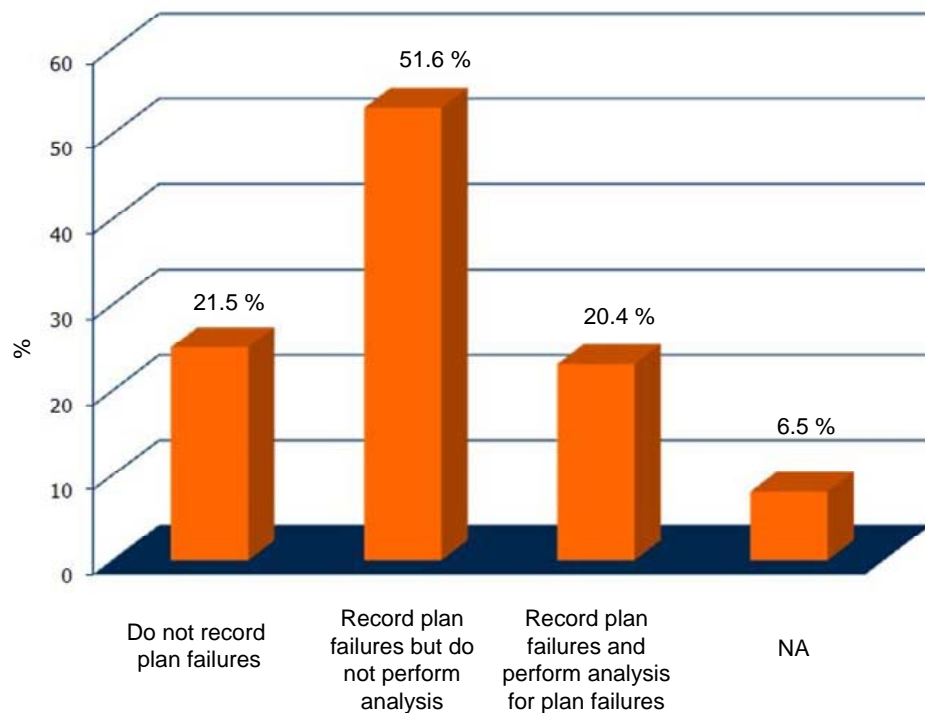

Figure 1.5: Survey results showing the percentage of organizations addressing plan failures on the weekly work plan.

#### ***1.1.4 Findings from the Pilot Case Study and Industry***

Research findings from the pilot case study and the industry survey highlight various issues related to production planning and execution. They raise concerns with current

planning practice and the current implementation of the LPS including. These concerns include:

- Absence of integrated and standardized planning processes (e.g., specialty contractors follow different planning practices than the general contractor on the same project).
- Sluggish removal of constraints.
- Top-down push of construction schedules.
- Absence of collaborative planning processes.
- Modest organizational learning.
- Poor performance of scheduling software packages that enable schedule coordination and real time feedback.
- Late implementation of constraint analysis (leaves short lead time to remove constraints).
- Deficient analysis for reasons behind plan failure.
- Poor linkage between weekly work plans and the master schedule reducing the planning-system ability to develop foresight and support a reliable workflow.
- The inability of Percent Plan Complete (PPC) (performance of weekly work plan) to represent the overall project's progress (e.g., PPC can be high while the project suffers from schedule delays).

### ***1.1.5 Research Motivation and Significance***

While working as a construction engineer for seven years on challenging construction projects, I developed a passion for analyzing and improving construction operations. This passion stimulated my research in lean construction in an effort to address the aforementioned concerns and offer process improvements. Working as a planning engineer and a project coordinator helped me develop an understanding of planning practices, team dynamics, and process improvement. This skill set proved beneficial for performing research in project planning.

This study addresses the concerns mentioned and focuses on the lookahead planning process as a bridge between weekly work planning (commitments) and master scheduling (ultimate project goals). The study aims to: (1) advance the implementation of the LPS as a standard system for collaborative production planning and control; (2) improve the lookahead planning process; and (3) increase PPC while increasing the connectedness of weekly work plans to the master schedule.

While some may question the significance of pursuing this focus in research, previous research has shown a positive impact of implementing the LPS on labor productivity and workflow (Ballard and Howell 1998, Ballard et al. 2007, Liu and Ballard 2008). Figure 1.6 shows a substantial increase in productivity when implementing the LPS on a construction project (Alarcon and Cruz 1997).

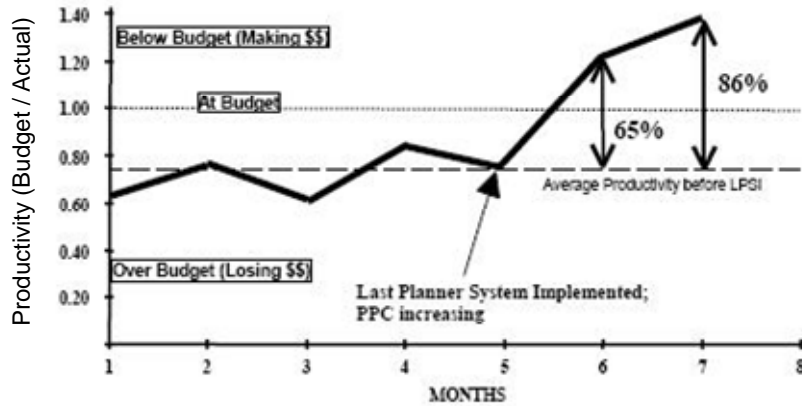

Figure 1.6: The relationship between productivity and implementing the LPS (Alarcon and Cruz 1997).

Moreover, Liu and Ballard (2008) highlight the importance of increasing PPC by showing the relationship between PPC and labor productivity. Figure 1.7 presents a scatter plot and linear regression showing the positive correlation between productivity increase and PPC increase.

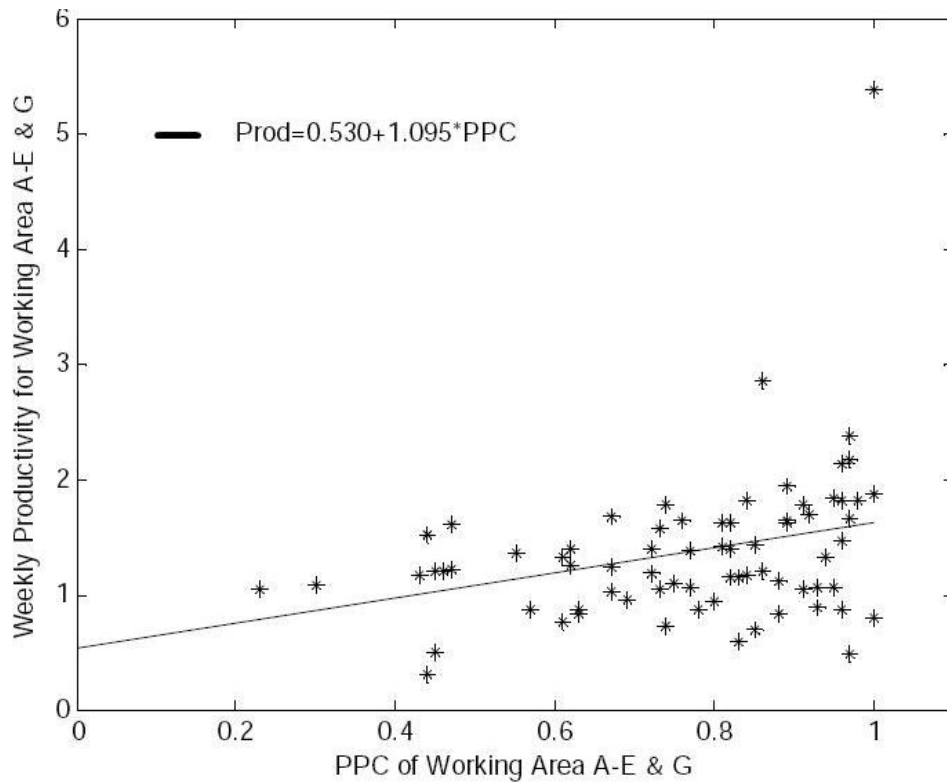

Figure 1.7: Scatter plot and linear regression between productivity and PPC (Liu and Ballard 2008).

Although previous research highlights the relationship between productivity and PPC, a gap exists in studying the relationship between PPC and project progress. Results from the pilot study suggest poor connectedness between weekly work plans and the master schedule, and poor performance of lookahead planning as a bridge between the two. Accordingly, research is needed on methods to increase PPC (increase productivity) and improve lookahead planning while improving the connectedness of weekly works plans (commitments) to the master schedule (ultimate project goals).

## **1.2 Research Methodology**

This section introduces the methodology used to conduct the dissertation research. It is a blueprint of the research process from inception to completion. Figure 1.8 illustrates the steps taken in the research process. Research started by a literature review, a pilot case study to investigate the current implementation of LPS, and an industry survey. Consequently, these preliminary research tasks uncovered significant problems: poor linkage between long-term (master scheduling) and short-term planning (weekly work planning), reducing the ability of the planning system to develop foresight and support a reliable workflow; the inability of PPC to relate to the overall project's progress; and the absence of integrated and standardized planning processes. With these problems in mind, the goal set for this study focuses is to close the gap between long-term and short-term planning by improving lookahead planning and increasing PPC (ultimately productivity), while increasing the connectedness between weekly works plans and the master schedule.

Several research questions emerged as a result of this preliminary work. Accordingly, a research design plan was developed as presented in Figure 1.8. The process starts from the preliminary work (previous research, pilot case study, and



industry survey), inferred problem and goals / objectives. The following steps include: research methods, data collection mechanisms/tools, data analysis, and validation of results to reach to the expected contributions. The following sections describe each step and explain its role within the whole process.

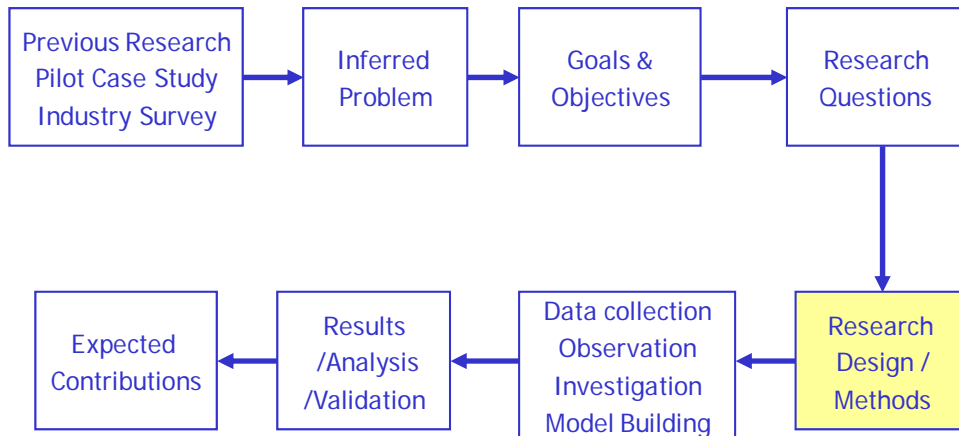

Figure 1.8: Layout of the research process.

### 1.2.1 *Research Goal and Objectives*

The goal of this research is to close the gap between long-term and short-term planning. The strategy for achieving this goal is to improve lookahead planning and increase the connectedness between weekly work plans and the master schedule, by increasing the selection and execution of tasks critical to project success. This is expected to make PPC not only a measure of reliable release of work from one specialist to the next (and hence a proxy for increased labor productivity), but also a measure of project progress. To achieve this goal an understanding of system design and execution is required. In this context, two objectives are defined.

**Objective 1: Understand the reasons behind the poor connection and wide gap between long-term planning (master scheduling) and short-term planning**

**(weekly work planning)**. Understanding the reasons is the first step to formulating improvement strategies as one cannot manage what one does not understand. This requires a study of current planning processes and suggesting improvements.

**Objective 2: Explore and experiment with methods for increasing the connection between weekly work plans and the master schedule while increasing PPC.** This entails improving the lookahead planning process that links weekly work planning and master scheduling processes. Accordingly, an understanding of the status of current lookahead planning processes is required before suggesting process improvements and applying them on construction projects.

### ***1.2.2 Hypothesis***

A hypothesis predicts the relationship between two or more variables (Gliner and Morgan 2000). Three factors of interest are involved: parameters, independent variables, and dependent variables. Parameters are factors that help characterize the population of interest. They are held constant during a case study but can vary from one case study to another as population characteristics might change. They are controlled for by selecting a case study that matches certain parameters (Meredith 1998). Independent variables are those factors that can affect the outcome of a measure of interest. They can be manipulated in the case of experiments and sometimes, as in most case studies, only observed. A dependent variable is an outcome or measure influenced by one or more independent variables (Meredith 1998, Gliner and Morgan 2000).

This dissertation presents the following hypothesis: Improving the lookahead planning process improves the performance of weekly work planning, increases PPC, and

increases the connectedness between weekly work plans and the master schedule by increasing the selection of tasks critical to project success.

### ***1.2.3 Research Questions***

The process of exploring relevant literature, analyzing results from the pilot case study and the industry survey, discussion with dissertation committee members and other scholars, and talking to industry practitioners, spawned a large number of research questions. After deliberation, two main research questions were shortlisted and selected based on the following criteria: (1) questions should be specific to an area of interest; (2) questions should not be too narrow; (3) answers to these questions can be measured in practice; and (4) questions should be interesting to the researcher (Bernard 2000, Stuart et al. 2002, Creswell 2003, and Cheshire 2007).

Question 1: What are the reasons behind the poor link between weekly work plans and the master schedule and what causes PPC to become a poor predictor of project performance?

Question 2: How to structure the lookahead planning process to increase PPC while increasing the connectedness of weekly work plans to the master schedule and making PPC a better predictor of project success?

### ***1.2.4 Research Scope and Focus***

This study was limited to projects in the building construction sector and specifically commercial, educational, residential, and health care projects. Locating the scope within the Lean Project Delivery System triads, this research addresses processes that take place

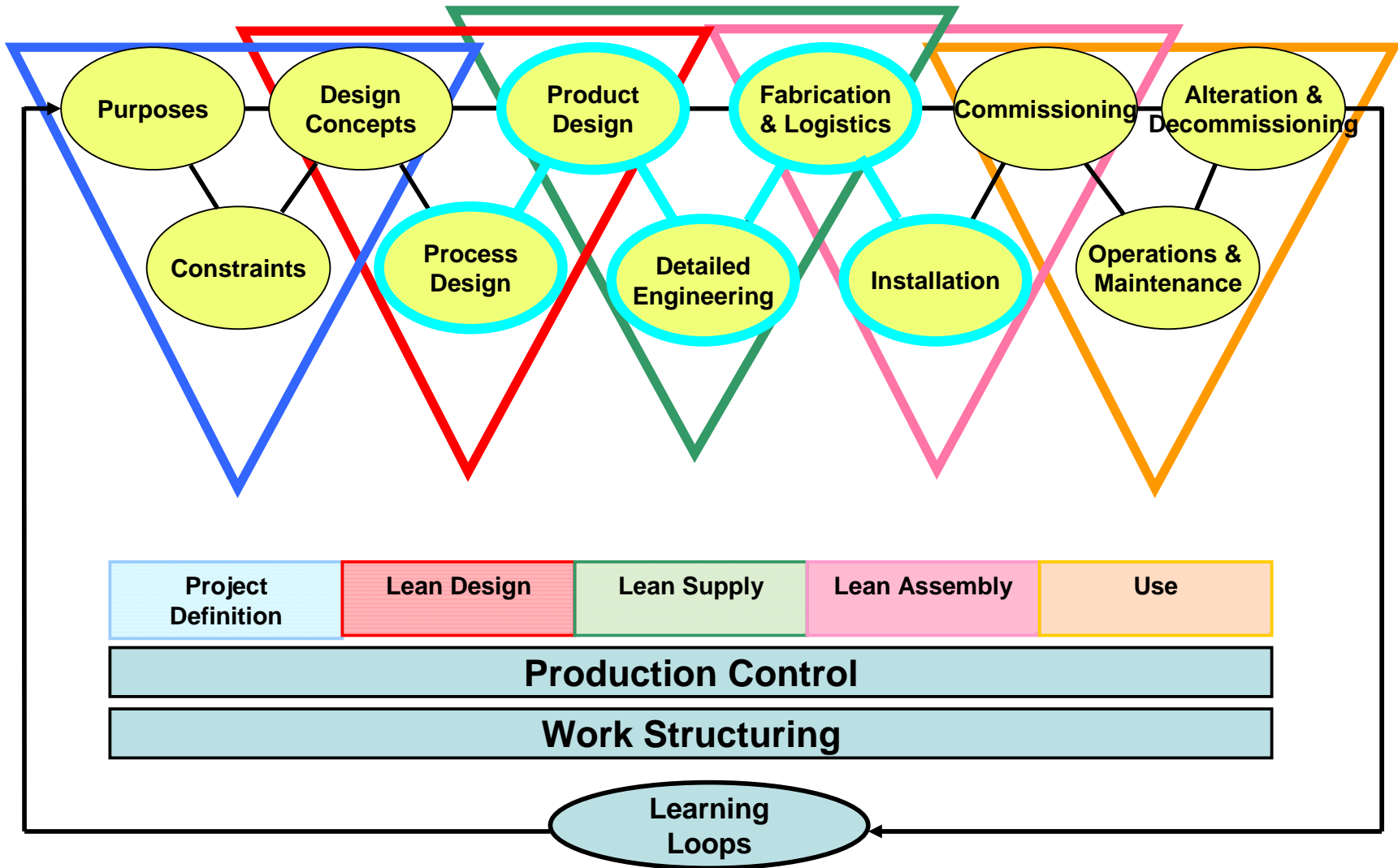

Figure 1.9: Research scope within the LPDS system (Ballard 2006).

during the design, supply, and assembly phases of a project as shown in Figure 1.9 (Ballard 2000b).

### ***1.2.5 Research Design***

Research design is a plan to get from a set of research questions to answers or explanatory conclusions. It selects and assigns methods of evidence collection to address the research questions. The plan looks at the methods required to answer each question, how and what data to collect, and how to analyze data (Yin 2003).

An examination of the research questions suggests that a case-study research strategy is appropriate. Case-study research: (1) is an appropriate strategy for answering questions pertaining to ‘how’ and ‘why’, when no control for behavioral events is required, and when research focuses on contemporary affairs; (2) uses both quantitative and qualitative methods to explain phenomena; (3) can employ quantitative methods to answer questions; (4) can explain causal links using real-life evidence and utilize observational richness to prove or refute causality by uncovering any spurious relationships; (5) uses multiple sources of evidence in a natural setting that encompasses temporal and contextual facets of the variables monitored; (6) uncovers the dynamics of events explaining the phenomenon under study; (7) can employ rigorous evidence collection, description, observation and triangulation; and (8) provides qualitative understanding when arriving at conclusions and analyzing results (Meredith 1998, Stuart et al. 2002, Yin 2003).

This study uses both quantitative and qualitative methods to address the research questions. Quantitative methods can explain what happens and how it happens, providing ground for prediction based on the data collected and analyzed. Qualitative methods

provide good answers for ‘how’ and ‘why’ questions. Moreover, they help in understanding the nature of the phenomenon under study and describe the factors influencing a desired measure. Accordingly, this study employs both quantitative and qualitative research tools including direct observation (site visits, meetings, training sessions), visuals (photos, video, drawings, diagrams, Building Information Modeling (BIM) models, reports), documents (schedules, last planner reports, meeting minutes, orders, change orders, design changes), process mapping, interviews, simulation, and a survey.

The following is the plan followed to answer the research questions laid out in this study. Table 1.2 summarizes the research tools involved in answering the research questions.

**Question 1:** What are the reasons behind the poor link between weekly work plans and the master schedule and what causes PPC to become a poor predictor of project performance?

Answering this question required developing an understanding of current planning processes, using the understanding to suggest process improvements, and testing these improvements in industry. The primary case study described in Chapter 3 formed fertile grounds for studying intermediate planning processes and experimenting with process improvements. The resulting recommended improvements are described in Chapter 4. The three cases presented in Chapter 5 enrich our understanding of current practice and present ideas for future improvements. The results of the simulation model presented in Chapter 6 reinforce the understanding and process improvements presented in Chapters 3 and 4.

**Question 2:** How to structure the lookahead planning process to increase PPC while increasing the connectedness of weekly work plans to the master schedule and making PPC a better predictor of project success?

To answer this question, Chapter 3 presents current intermediate planning processes (lookahead planning), and analyzes a lookahead planning process implemented on a current construction project. Chapter 4 presents a suggested framework for implementing the LPS in general, and the lookahead planning process in particular. Chapter 6 presents different simulations highlighting the impact of improving lookahead planning on PPC.

Table 1.2: Research tools employed to answer research questions

Question	Tools Used
Question 1	Direct observation, visuals, documents, interviews, process mapping, LPS data, and survey results.
Question 2	Direct observation, visuals, documents, interviews, process mapping, LPS data, and simulation.

### **1.2.6 Case Studies**

I conducted multiple case studies to provide more compelling evidence and contribute to the robustness of the study. Every case is selected for a specific purpose addressing one or more research questions. Figure 1.10 shows the proposed case study design for this dissertation. In adding new case studies, replication, not sampling, is sought. Specifically, replication of findings in the first case study is what I sought in the second or third case study. Moreover, replication takes two forms: (1) literal replication, which takes place when two case studies produce close results; and (2) theoretical replication, which occurs

when results between two cases contrast under contrasting conditions. Therefore, adding a new case study to research is not increasing sample size; rather it is expanding research into new populations. Choosing a case study requires selecting the exact type of replication sought, examining site conditions, and confirming their conformance to certain desired population characteristics (Meredith 1998 and Yin 2003).

The pilot case study mentioned before was selected for the following reasons referred to Yin (2003): the project is a good testing ground for developing data gathering mechanisms, the site is suitable and accessible, and the case is complicated to put data collection procedures into test and uncover data collection issues.

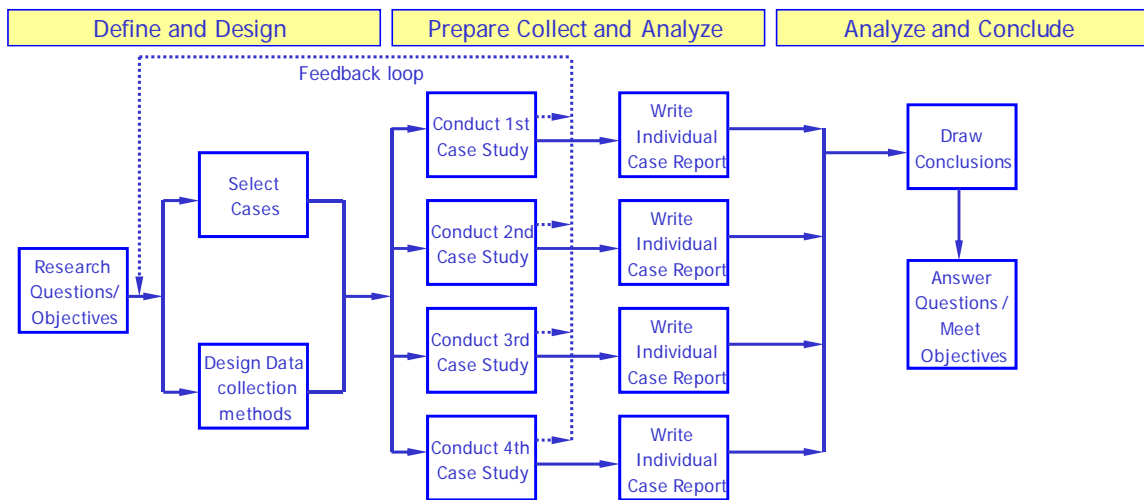

Figure 1.10: Case study research design (modified after Yin 2003).

### 1.2.7 Data Analysis

This study employs multiple sources of evidence when collecting and analyzing data. Using multiple sources of evidence in case studies gives an investigator the opportunity to address historical, attitudinal, and behavioral issues. This study pays attention to analyzing and interpreting inputs from practitioners and insights into the phenomenon



under study. Using multiple sources of evidence is necessary to develop a process of triangulation where different lines of inquiry converge. Accordingly, this study utilizes the following types of triangulation (Meredith 1998, Stuart et al. 2002, Yin 2003):

- 1- Data triangulation using different sources of evidence (LPS project data, interviews, simulation).
- 2- Investigator triangulation (comparing results with other studies and evaluators).
- 3- Theory triangulation (investigating different perspectives on the same data).
- 4- Methodological triangulation (employing quantitative and qualitative methods).

### ***1.2.8 Validation of Results and Attaining Research Rigor***

Providing quality case-study research and research rigor requires applying the four tests of validity to research design: (1) construct validity, (2) internal validity, (3) external validity, and (4) reliability.

Construct validity can be achieved by formulating suitable measures for the variables and phenomena under investigation. This research approaches construct validity by employing multiple sources of evidence, laying out a chain of evidence, and having key evaluators/ informants review the case study report.

Internal validity is concerned with investigating causal links and uncovering spurious relationships. In addition to the quantitative scheme, this research employs a qualitative approach and logical models to explain patterns and examine rival perspectives.

External validity is related to generalizing case study findings to broader domains or populations. This research seeks a theoretical generalizability where the hypothesis is

tested on different cases with different situations. Moreover, it incorporates independent variables to achieve greater depth in observation, and thus enhance generalizability.

Reliability explains the degree to which the same steps performed in the study can be replicated by other researchers. This research tackles this issue by keeping a clear record of those steps for future reference (Meredith 1998, Stuart et al. 2002, Yin 2003).

### ***1.2.9 Research Limitations***

The study has several research limitations including: (1) survey interpretation, (2) lack of standardized planning processes, (3) limited availability of data and documentation, and (4) modeling limitations.

1- Interpretation of survey results is a well know limitation. For example, the interpretation of questions impacts the answers and the results. In addition, non-response bias is another limitation.

2- The lack of standardized planning practices, especially when applying the LPS across different projects is a hurdle to a fair comparison of performance.

3- The data required for research is not readily available. The available data on the LPS is incomplete and sometimes unsuitable for the required research. Data had to be processed and interpreted. Data interpretation and processing might introduce an additional bias.

4- Modeling limitations are related to the simulation model which is presented in Chapter 6). Some of the limitations include: fitness of model to theory, model validation, model assumptions, statistical analysis, and fitness of experimental design (Dooley 2002).

### ***1.2.10 Personal Motivation***

“When you are inspired by some great purpose, some extraordinary project, all your thoughts break their bounds: your mind transcends limitations, your consciousness expands in every direction and you will find yourself in a new, great and wonderful world. Dormant forces, faculties and talents become alive, and you discover yourself to be a greater person by far than you ever dreamed yourself to be.” Patanjali (Lore 1998)

My rationale for pursuing this research falls under the four causes advocated by Aristotle for understanding how things come into existence: (1) the material cause, (2) the formal cause, (3) the efficient cause, and (4) the final cause (Aristotle 350 B.C. /1970).

The material cause explains what the object is made from. Although this should cover the physical object, I want to expose here the non-physical object in the form of ideas and theories. This research was a result of: (1) my quest for optimization during all the time I worked on construction projects, (2) research and study of the body of knowledge on project management, lean construction, and supply chain management, (3) ideas collected through interface with scholars and practitioners, and (4) support from an educational institution and a body of educators.

The formal cause considers the form or essence of an object. By convention, research outcomes at the Ph.D. level must take the form of a dissertation as means of contributing to knowledge and graduating from university.

The efficient cause points to the person who is working on the object. In this case, the efficient cause defines the author’s pursuit of a career in academia, laying the cornerstone for his future research in areas of project management, lean construction, and supply chain management.

Finally, the final cause describes the purpose for taking an action. However, to explain the real purpose behind an action, one should ask ‘why’ many times before coming to the grand or final cause. Writing this dissertation has a deeper goal than attaining a Ph.D. from one of the most prestigious institutions; the grander end goal is self actualization, living a life in accordance with reason, and contributing to good in the world.

While these causes may seem implicit, they are the main reasons behind my ongoing quest for learning and continuous improvement.

### **1.3 Dissertation Structure**

Figure 1.11 lays out the structure of this research from introduction to conclusion. While Chapter 1 presents research background, significance, and methodology, Chapter 2 presents a review of the relevant literature that made this study possible. Chapter 3 presents the main case study where suggested improvements for lookahead planning were developed and tested. Chapter 4 presents supporting case studies showing data and results of planning processes on three construction projects. Chapter 5 lays out a framework for operational implementation of the LPS.

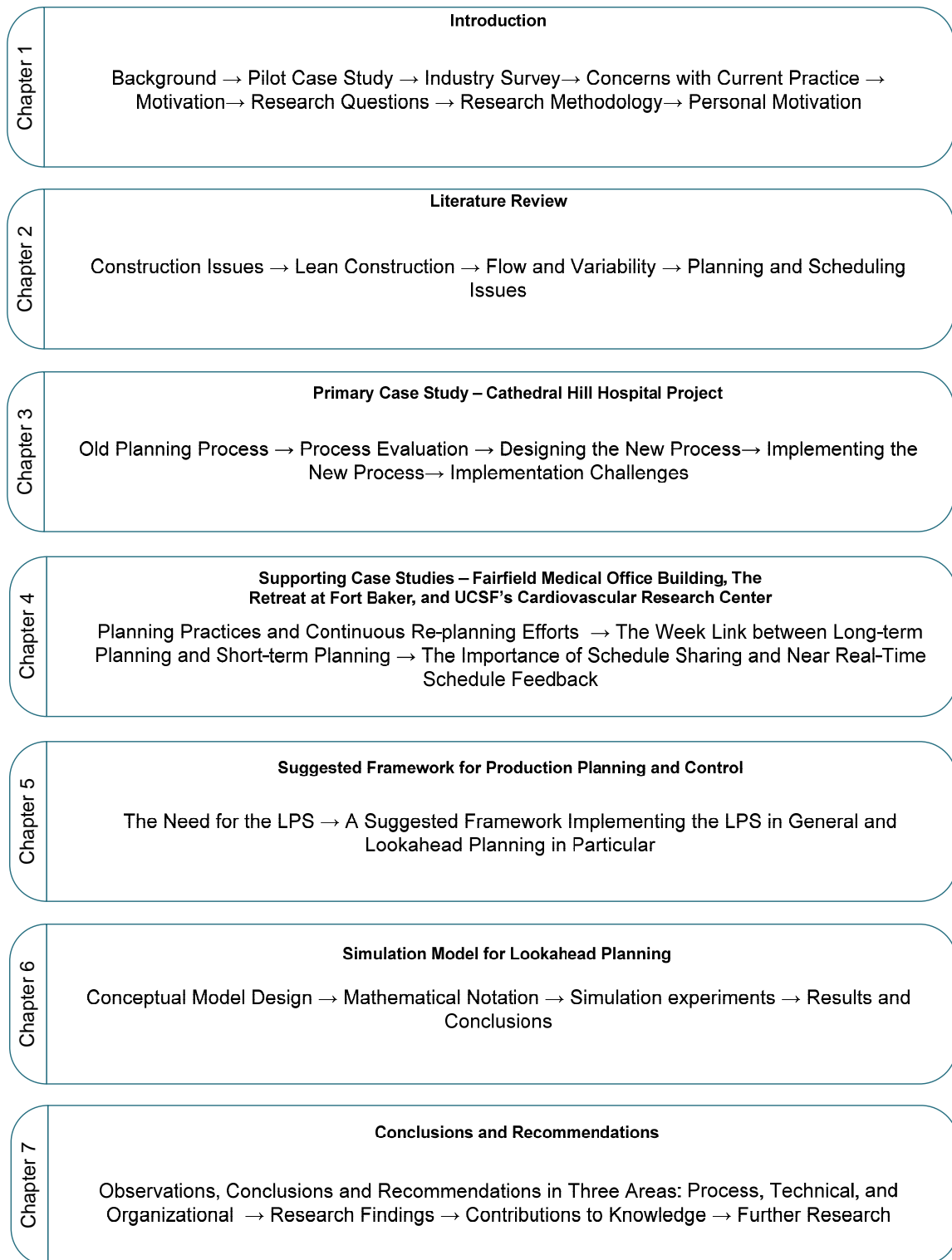

Figure 1.11: Dissertation structure.

Chapter 6 introduces simulation to show the impact of improving lookahead planning on increasing PPC. Chapter 7 highlights the study conclusions, observations and recommendations for process improvements. It summarizes research findings and contributions to knowledge. It also presents potential areas for future research.

#### 1.4 References

- Alarcon, L. (editor) (1997). *Lean Construction*. A.A. Balkema, Rotterdam, The Netherlands, 497 pp.
- Alarcón, L. F., and Cruz, J. C. (1997). "The Impact of Project Planning Performance on Project Outcomes", *Tenth World Productivity Congress*, October, Santiago, Chile, pp. 12-15.
- Alves, T.C.L. (2005) *Buffering Practices in HVAC Supply Chains*. Ph.D. Dissertation- Civil and Environmental Engineering, University of California, Berkeley, U.S.A.
- Aristotle (350 B.C. / 1970). *Aristotle's Physics Books I & II*. Translated with introduction and notes by W. Charlton, Clarendon P., Oxford, pp. 151.
- Ballard, G., (1997). "Lookahead Planning: The Missing Link in Production Control", *Proceedings of the 5th Annual Conference of the International Group for Lean Construction, IGLC 5*, July, Gold Coast, Australia.
- Ballard, G. (2000a). *The Last Planner System of Production Control*. Ph.D. Thesis, Faculty of Engineering, School of Civil Engineering, The University of Birmingham.
- Ballard, G. (2000b). "Lean Project Delivery System." *Lean Construction Institute*, White Paper No.8, Ketchum, Id. <http://leanconstruction.org/pdf/WP8-LPDS.pdf>
- Ballard, G. (2000c). "Phase Scheduling" White Paper #7, *Lean Construction Institute*, April 27, 3 pp.
- Ballard, G., (2006). "Rethinking Project Definition in Terms of Target Costing," *Proceedings of the 14th annual conference of the International Group for Lean Construction*, July, pp. 77-89.
- Ballard, G., Hammond, J., and Nickerson, R. (2009). "Production Control Principles", *Proc. 17<sup>th</sup> Annual Conf. Intl. Group for Lean Construction*, Taipei, Taiwan.

- Ballard, G., and Hamzeh, F.R. (2007). “The Last Planner Production Workbook- Improving Reliability in Planning and Workflow”, 2<sup>nd</sup> Edition, *Lean Construction Institute*, San Francisco, California, USA, pp. 81.
- Ballard, G., and Howell (1994). “Implementing Lean Construction: Stabilizing Workflow”, *Proceedings of the 2nd Annual Conference of the International Group for Lean Construction, IGLC 2*, Santiago, Chile. In: *Lean construction (1997)*, edited by Luis F. Alarcón C. A A Balkema, Rotterdam.
- Ballard, G., and Howell, G. (1998). ”Shielding Production: An Essential Step in Production Control”, *Journal of Construction Engineering and Management*, ASCE, 124 (1), pp. 11-17.
- Ballard, G., and Howell, G. (2004). “An Update on Last Planner”, *Proc. 11th Annual Conf. Intl. Group for Lean Construction*, Blacksburg, Virginia, USA, 13 pp.
- Ballard, G., Tommelein, I. D., Koskela, L., and Howell, G. (2003). *Lean Construction Tools and Techniques (Chapter 15) of Design and Construction: Building in Value*, Butterworth Heinemann, pp. 227-255.
- Bernard, H.R. (2000) *Social Research Methods- Qualitative and Quantitative Approaches*, Sage Publications, Thousand Oaks, Ca, 659 pp.
- Bertelsen, S., Koskela, L., Heinrich, G., and Rooke, J.(2006)” Critical Flow – Towards a Construction Flow Theory”. *Proceedings of the 14th Annual Conference of the International Group for Lean Construction, IGLC 14*, Santiago, Chile.
- Cheshire, C. (2007) *Quantitative Research Methods*, IS 271 B course notes, University of California at Berkeley.
- Creswell, J.W., (2003). *Research Design- Qualitative, Quantitative, and Mixed Methods Approaches*, second edition, Sage Publications, Thousand Oaks, CA, 246 pp.
- Crichton, C. (1966). *Interdependence and Uncertainty: A study of the building industry*. Tavistock Institute, Tavistock Pubs., London, pp. 83.
- Gliner, J.A., and Morgan, G.A. (2000) *Research Methods in Applied Settings: An Integrated Approach to Design and Analysis*, Lawrence Erlbaum Associates Publishes, NJ, 465 pp.

- Gonzalez, V., Alarcon, L.F., and Mundaca, F. (2008). "Investigating the relationship between planning reliability and project performance", *Production Planning & Control*, Vol. 19, No.5, July, pp. 461-474.
- Green, S.D., Fernie, S., and Weller, S. (2005) "Making Sense of Supply Chain Management: A Comparative Study of Aerospace and Construction". *Construction Management and Economics*, July, pp. 579-593.
- Hamzeh, F.R., Tommelein, I.D., Ballard, G., and Kaminsky, P. (2007). "Logistics Centers to Support Project-Based Production in the Construction Industry", *Proceedings of the 15th Annual Conference of the International Group for Lean Construction, IGLC 15*, 18-20 July, East Lansing, Michigan, USA, pp. 181-191.
- Hamzeh, F.R., Ballard, G., and Tommelein, I.D. (2008). "Improving Construction Workflow- The Connective Role of Lookahead Planning", *Proc. 16<sup>th</sup> Ann. Conf. Int'l. Group for Lean Constr., IGLC 16*, 16-18 July, Manchester, UK, pp. 635-646.
- Hopp, W.J., and Spearman, M.L. (1996). *Factory Physics*, 1<sup>st</sup> Ed., Irwin, Chicago, 668 pp.
- Hopp, W.J., and Spearman, M.L. (2008). *Factory Physics*, 3<sup>rd</sup> Ed., Irwin/ McGraw-Hill, Boston, 720 pp.
- Howell, G. and Ballard, G. (1998) "Implementing Lean Construction: Understanding and Action" *Proc. 7<sup>th</sup> Ann. Conf. Int'l. Group for Lean Constr.*, Guaruja, Brazil.
- Koskela, L. (2000). An exploration towards a production theory and its application construction. PhD Thesis, University of Technology, Espoo-Finland.
- Liker, J.K. (2004). *The Toyota Way- 14 Management Principles from the World's Greatest Manufacturer*. McGraw Hill, NY, 330 pp.
- Liu, M., and Ballard, G. (2008). "Improving Labor Productivity Through Production Control", *Proc. 16<sup>th</sup> Ann. Conf. Int'l. Group for Lean Constr., IGLC 16*, 16-18 July, Manchester, UK.
- Lore, N. (1998). *The Pathfinder: How to Choose or Change Your Career for a Lifetime of Satisfaction and Success*, Simon & Shuster Adult Publishing Group, 400pp.
- Meredith, J. (1998) "Building Operations Management Theory through Case and Field Research." *Journal of Operations Management*, 16, pp. 441-454.



- Nahmias, S. (2009) *Production and Operations Analysis*. 6<sup>th</sup> edition, McGraw Hill/Irwin, NY, pp. 789.
- Ohno, T. (1988). *Toyota Production System- Beyond Large-Scale Production*. Productivity Press, Cambridge, MA. 143 pp.
- Stuart, I., McCutcheon, D., Handfield, R., McLachlin, R., Samson, D. (2002) "Effective Case Research in Operations Management: A Process Perspective." *Journal of Operations Management*, 20, pp. 419-433.
- Thompson, J.D. (1967). *Organizations in Action*. McGraw-Hill, New York.
- Tommelein, I.D. (2003). "Acknowledging Variability and Uncertainty in Product and Process Development." Chapter in Issa, R.R.A., Flood, I., and O'Brien, W.J. (editors) *4D CAD and Visualization in Construction: Developments and Applications*, A.A. Balkema Publishers, pp. 165-193.
- Tommelein, I.D. and Ballard, G. (1997). "Look-ahead Planning: Screening and Pulling." *Technical Report No. 97-9*, Construction Engineering and Management Program, Civil and Environmental Engineering Department, University of California, Berkeley, CA, USA.
- Tommelein, I.D., and Weissenberger, M. (1999). "More Just-In-Time: Location of Buffers in Structural Steel Supply and Construction Processes," *Proceedings of the 7th International Group for Lean Construction Conference*, Berkeley, CA, USA.
- Vrijhoef, R., Koskela, L. (2000). "The Four Roles of Supply Chain Management in Construction", *European Journal of Purchasing & Supply Management*, (6), pp. 169-178.
- Yin, R.K. (2003). *Case Study Research- Design and Methods*, third edition, Sage Publications, Thousand Oaks, CA, 181 pp.

## ***CHAPTER 2 - LITERATURE REVIEW***

This chapter reviews the relevant professional and research developments that have influenced this study and is divided into five sections. Section 1 introduces the Supply Chain Management and the Lean Construction views of production systems. Section 2 presents the relevant literature on flow and variability and explains the need for using the Last Planner™ System (LPS) in construction, and section 3 discusses Supply Chain Management and Logistics. Section 4 introduces the concept of waste and discusses the different types of waste in production. Section 5 highlights the importance of planning and scheduling in production systems and sheds light on planning and scheduling in uncertain environments.

### **2.1 Background**

This study is conducted at a time when business processes are becoming more global than ever before; companies are looking for sources of competitive advantage beyond the organizational boundaries; information technology is advancing quickly; and organizations are looking for new ways to decrease costs and enhance operations (Ayers 2006, Hamzeh et al. 2007, Miles and Snow 2007).

#### ***2.1.1 The Supply Chain Management View***

The term *Supply Chain Management* (SCM), used to describe collaborative management processes of a network of different parties, came into existence relatively recently in the 1980's. As a concept, SCM evolved from many older fields, mainly logistics. The supply

chain, previously understood as driven by the supplier pushing products and services to the customer, had to undergo a paradigm shift with the emergence of the Just-in-Time (JIT) concept under the Toyota Production System. The JIT philosophy is about reducing inventory to expose production problems. In fact, JIT required a change in old manufacturing methods by smoothing production fluctuation, reducing setup times, reducing production processes redesign, and standardizing many tasks. Consequently, JIT made demand pull from the customer possible and eliminated the need for holding large inventories (Shingo 1988, Vrijhoef and Koskela 2000, London and Kenley 2001, Laseter and Oliver 2003, Metcalfe 2004).

Since then, supply chains have been continuously evolving through three main stages: the first focused on improving process efficiency across the chain; the second promoted supply chain effectiveness by incorporating innovations and the expertise of involved parties; the third concerned knowledge management and full collaboration, where supply chains are extended across various industries, each functioning efficiently and effectively (Miles and Snow 2007).

The recognition of the SCM benefits spawned research in the topic that has been growing since the 1990's. SCM research is moving slowly from the project level focus to a broader production system perspective that covers the supply chain of owners, designers, suppliers, builders and operators. Still, interest in implementing the SCM concepts in construction has been rising ever since Ohno, Shingo, and Womack et al. introduced the *Toyota Production System* to the world (Ohno 1988, Shingo 1988, Womack et al. 1990, Vrijhoef and Koskela 2000, London and Kenley 2001, Tommelein et al. 2003, Alves 2005, Tommelein et al. 2009).

### ***2.1.2 The Lean Construction View***

Construction is a highly fragmented industry with low levels of trust, low economies of scale, modest vertical integration, limited research and development, temporary project parties, low barriers to entry, transient project locations, mostly local markets, high levels of variability, and predominantly unique construction projects (Vrijhoef and Koskela 1999, Koskela 2000, Alves 2005 , and Green et al. 2005).

Consequently, construction production suffers from: a myopic view of parties due to the lack of global optimization efforts, high levels of wastes in various forms, lack of communication and transparency, low customer satisfaction, and most importantly high variability in operations (Vrijhoef and Koskela 2000, Hopp and Spearman 1996, Hopp and Spearman 2008, Green et al. 2005).

While variability can be useful in certain cases (e.g., as in the case of product variety that can increase customers' satisfaction), variability in production undermines system performance, leading to detrimental consequences on cost, duration, quality, resource assignment, flow path, and sequencing. Consequently, understanding and managing variability is indispensable to improving construction operations. If variability is not reduced, the system pays dearly in terms of lost production throughput, wasted capacity, increased cycle times, high levels of inventory, long lead times, poor quality, and, ultimately, unhappy customers (Hopp and Spearman 1996, Hopp and Spearman 2008, Tommelein 2003).

To reduce the impact of variability on a system's operation, buffers of different types and sizes are usually introduced at different locations along the chain. Taking different forms such as money, time, capacity, inventory, space, and information, these

buffers place a heavy burden on the system in terms of extra cost and reduced performance. Accordingly, many improvements founded in lean theory focus on reducing variability and its damaging consequences.

Lean is a business philosophy inspired by the Toyota Production System (TPS). Lean is often misunderstood as a combination of tools and methods such as JIT (just-in-time), aimed at increasing production efficiency and forcefully reducing waste. Womack and Jones (2003) define a lean enterprise as a corporation that strives to: (1) increase value for customers when delivering goods or services, (2) identify steps in the value stream and remove those that are non-value adding, (3) organize the remaining value-adding steps to flow smoothly towards the customer, (4) streamline activity flow according to pull from the customer, and (5) pursue perfection through an endless journey of continuous improvement.

Accordingly, lean is a business philosophy and a system for organizing and managing processes including product development, design, production, operations, supply chain interactions, and customer relationships, to increase value and minimize waste. Lean is a perpetual quest for perfection pertinent to organizational purpose, business processes, and developing people.

Lean construction is a movement in the construction industry concerned with applying lean principles to improve construction practices, educating professionals, and performing research to evaluate current issues and recommend advancements. Ballard and Howell (1998), through their research on public and private construction projects, report “high work flow uncertainty, ineffective production unit planning, and high percentages of nonproductive time.” Moreover, they highlight the major reasons for

failure to complete planned work assignments are, “missing materials and failure to complete previous work”.

Ballard and Howell devised the LPS to shield downstream production from variability in upstream processes. This method was implemented on different construction projects to reduce uncertainty in work flow and improve work planning. In fact, the last planner system embodies the principles and human values of lean thinking (Howell and Ballard 1994b, Ballard and Howell 1998, Ballard 2000a, Ballard and Howell 2003).

Another development in lean construction research was the concept of work structuring, which focused on design, as well as execution of production systems. Work structuring can be defined as developing product design in alignment with process design, structuring supply chains, allocating resources, and designing offsite preassemblies to realize a reliable workflow and maximize customer value. This process should span across all project development phases, from definition through design, supply, and assembly (Ballard 2000a, Ballard et al. 2001, Ballard et al. 2003, Tsao et al. 2004).

Research in lean construction was strongly shaped by the emergence of the Transformation-Flow-Value (TFV) theory. This challenged the traditional perception of construction production as merely a transformation of inputs into outputs. Enriching the current transformation view with the value and flow concept, the TFV theory introduced a new premise of production centered on a flow of processes designed to reduce waste and maximize customer value. This theory also advocated designing, operating and

improving production from the combined perspective of transformation, flow, and value (Koskela 1992, Koskela 2000, Ballard et al. 2003).

While variability undermines project performance, production systems can be designed to manage uncertainty and reduce variability utilizing a combination of the above mentioned methods. A production system can be defined as a collection of people and resources (e.g., machinery, equipment, information) arranged to design and make a good or service of value for customers. An indispensable instrument for managing production systems in construction is the LPS for production planning and control which has been successfully implemented on construction projects to increase the reliability of planning, improve production performance, and assist in creating a predictable workflow (Ballard et al. 2007). Reliability describes the ability of plans to be executed by comparing planned work to actual work accomplished.

## **2.2 Flow and Variability**

### **2.2.1 *Lean Flow***

The flow view of production is not new. Although early perceptions of flow differ from our understanding today, some recognize the earliest scientific approach to flow in the work of Gilbreth and Gilbreth (1922) which advocated the use of process charting to improve production. Assembly line production, initially introduced by Henry Ford, is considered a huge step forward in implementing flow principles especially in arranging people, machines, tools, and products in a continuous manufacturing system (Ballard et al. 2003).

The Toyota Production System, as outlined in the writings of Ohno (1988), Shingo (1988), and Womack et al. (1990), provides a new look at production flow employing JIT as part of lean production. JIT focuses on inventory reduction, forcing the production system to expose production problems, and eventually improve the flow of production operations. JIT employs a signaling mechanism called Kanban to inform production when to produce in response to actual consumption. Thus, JIT creates a pull system reacting to actual demand. To facilitate pull and improve the flow of production, JIT requires reducing setup times, minimizing batch sizes, decreasing lead times, improving quality, and standardizing tasks (Liker 2004).

The lean analogy for flow is a river flowing evenly at a regular pace from source to customers. The river path does not contain dams, lakes, rapids or any major turbulence that disrupts the consistency of flow. The river delivers only what customers find valuable while incurring minimal wastes in the form of customer value loss and inventory. The river's banks are designed to adjust to water level changes within the designed limits (Ayers 2006).

### ***2.2.2 TFV Theory***

The flow view imbedded in lean production is well translated in the Transformation-Flow-Value (TFV) theory introduced by Koskela (1992). This theory goes beyond the transformation view of production to include flow and value. The basis of the traditional view of production is merely transforming inputs to outputs as efficiently as possible. However, TFV theory incorporates three views of production: transformation, flow, and value (Koskela 2000, Ballard et al. 2003, Elfving 2003).



The transformation view regards production as value creation, transforming inputs to outputs in a manner that suits customer expectations. The flow view, advocated by TFV, focuses on reducing and eliminating wastes and other non-value-adding activities from the value stream. The value stream is the sequence of activities in which value is added to product or service as it travels from design through manufacturing until it is delivered to the customer(s). Accordingly TFV is concerned with reducing lead times, decreasing variability, and simplifying processes. Moreover, TFV supports pull production control and continuous process improvement. The value view of TFV theory, answers the voice of the customer by delivering the best possible value to match what is considered valuable from a customer standpoint (Koskela 2000, Ballard et al. 2003).

Moreover, TFV theory calls for structuring, executing, and improving production from the combined view of transformation, flow, and value. Koskela introduced the seven-flows-view as an application of the TFV theory in construction ( Koskela 2000, Ballard et al. 2003).

### ***2.2.3 Construction Flows***

Execution of a construction activity requires the availability of one or more of seven major preconditions: previous work, information, material, equipment, crew/workers, space, and external conditions (after Koskela 2000). These preconditions are perceived as having a certain degree of flow, either coming into an activity or moving between activities. Moreover, timely availability, synchronization, and movement of these flows, shown in figure 2.1, dictate the probability of realization within the involved activity.

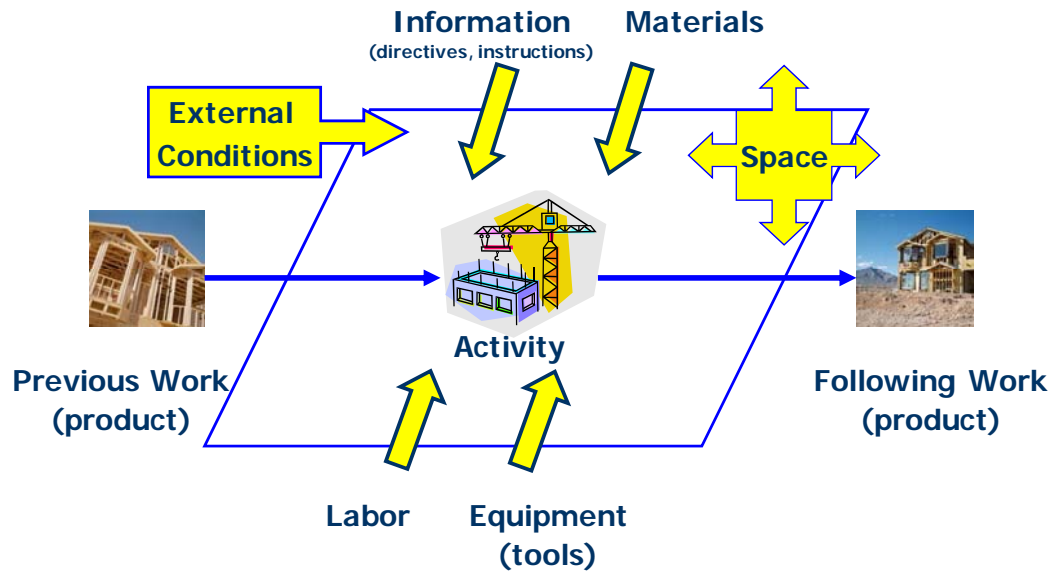

Figure 2.1: Flows involved in a construction activity; after Koskela (2000).

While flow is predominantly compared to a river flowing evenly at a consistent pace, the flows shown in Figure 2.1 have different flow patterns. Furthermore, these flows fall under many categories: product, resources, information (directives and instructions), additives, and external conditions (after Ballard et al. 2003).

Product flow represents the accretion of value on a construction project, one example is the value-added work applied to a substrate to form the final product demanded by the customer. The product moves through a network of activities, from previous work to following work, in a journey of value-gain, before becoming a finished product. Since the product does not move in construction the same way it moves in manufacturing, it can be operating in one of three states: worked on, waiting, or under inspection. Thus, flow in this case is uninterrupted work, where the product is expected to be worked on, and uninterrupted release of work, where the product is under inspection. Variability in product flow delays the realization of subsequent activities, as they inherit

variability from upstream flows. An example of product flow is a building skeleton that accumulates value as it is being worked on, taking the shape of an operational facility.

“Resources bear load and have finite capacities” (Ballard et al. 2003). Resource flow is the temporal and spatial flow of labor, equipment (including tools and instruments of labor), and space (Riley and Tommelein 1996). Labor, equipment, and space can be employed and released from one activity to another. Hence flow of these resources on site is related to handoff between activities, and consequently, has a great effect on production. Accordingly, variability in the availability of these resources has an impact upon activities that may face resource starvation.

Flow of additives includes material and assemblies. They are consumed into the product, and hence their flow is between supply sources and the construction site. Flow is directly related to design and performance of the supply chain. The higher is the variability in a chain, the higher is the variability in additive delivery. Howell and Ballard (1994a) draw attention to high variability in structural steel delivery on a construction site and highlight the varied impact on operations.

Information flow embodies a variety of prerequisites such as design data, specification, directives (such as change orders, notice to proceed, etc.), instructions (such as fabrication, assembly, testing, etc.), decisions, and performance standards. Information flow embodies different flow patterns. While activities do not consume information, its availability is a prerequisite to activity realization. Information flow is regarded as the timely arrival of information, decisions, directives, and instructions necessary for an activity to take place. Howell and Ballard (1994a) report a high rate of variability between planned and actual delivery of pipe isometric drawings, from the

engineer to the fabrication shop. The results show even higher variability between planned and actual fabrication.

Lastly, external conditions provide the environment for an activity to take place and do not necessarily have to flow. Their flow is just characterized by their mere existence to facilitate task realization, such as in the case of good weather. Absence of these conditions implies working under suboptimal conditions. Koskela (2000) suggests work under suboptimal conditions is often accompanied by reduced productivity.

#### ***2.2.4 Uncertainty in Construction Flows***

Koskela (2000) suggests that construction embodies assembly activities requiring a number of input flows. As Figure 2.1 shows, he distinguishes at least seven flows including: previous work, information, material, equipment, workers, space, and external conditions

Since activity completion depends on the intersection of these flows, this forms a matching problem or a merge bias. A merge bias can be defined as a variability impact on a successor activity by predecessor activities or prerequisite inputs flowing into that successor activity. As an example, assume that activities E and F (each with a duration of 3 days) are predecessors to activity G (finish-to-start relationship). Assuming E and F would finish in is less than 3 days (E and F will finish at time 3) with a 60 % chance. Then the chance that activity G will start at time 3 is only 36% (60% x 60%). This comes as a result of the merge bias and the impact of E and F on G (Tommelein 2006).

This matching problem or merge bias results from several flows combining to support an activity. Thus the realization of a successor activity relies on the synchronization of these flows. Accordingly, flow synchronization is contingent to

variability in each of these flows. While activity completion depends on these flows, the advancement of these flows into other activities downstream is contingent on activity completion. In other words, prerequisites or resources freed from a predecessor activity can now flow to a successor activity, while at the same time product output from the preceding activity can serve as previous work for the successor activity as shown in Figure 2.2 (Koskela 2000, Elfving and Tommelein 2003, Arbulu and Ballard 2004).

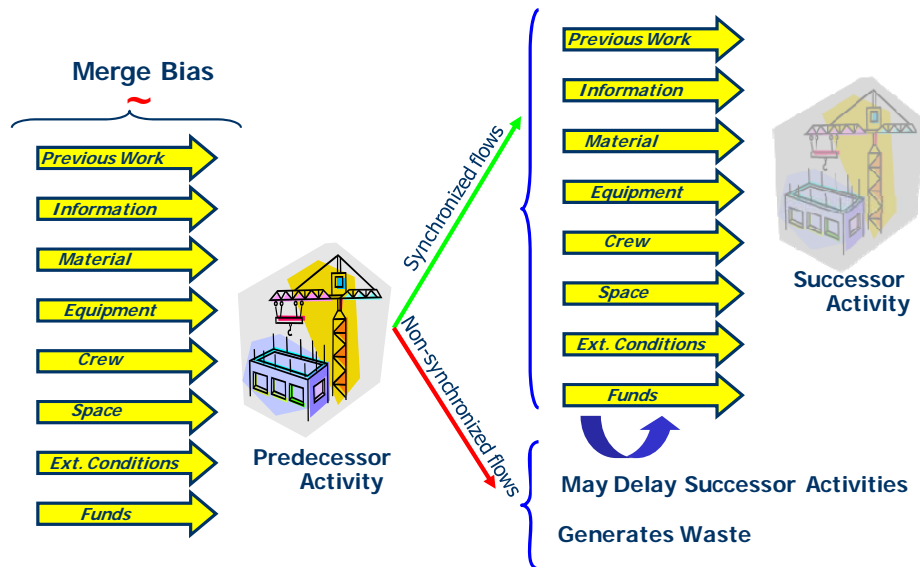

Figure 2.2: Effect of synchronized flow on successor activities.

Koskela highlights the weighted effect the uncertainty in intersecting flows has on task completion. A 5% uncertainty in each of the seven flows results in a task completion estimated as  $(0.95)^7 = 0.7$  or 70 % (Ballard and Howell 1998, Koskela 2000). Although, this calculation assumes that uncertainty in one flow is independent of the uncertainty in other flows, interdependence between flows is possible.

Assuming that certainty in one flow can be independent of certainty in other flows, Figure 2.3 shows the probability of task realization as a function of certainty in

one or more of the seven input flows. It can be inferred that when flow certainty in all flows drops below 50%, the probability of task realization approaches zero.

Shingo (1981) highlighted the difference between two types of flows: process flow and operations flow. Process flow was defined as, “the course through which the material is changed into the product,” and operations flow as, “the course through which man and machine work upon the product.” In this context, Shingo (1988) explained production as “a network of processes flowing along the y-axis and operations flowing along the x-axis” as shown in Figure 2.4.

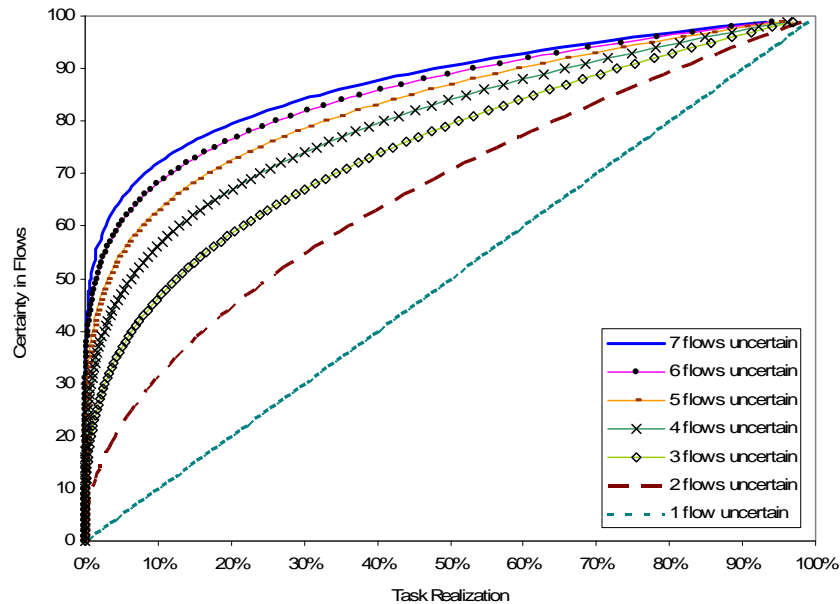

Figure 2.3: Task realization versus certainty in 1-7 input flows.

This study distinguishes different categories of flow including: product, resources, information and additives. Product flow represents the flow of the construction object along the value stream from a state of previous work to a state of following work. The product accumulates value as it progresses toward the final product that the customer wants. The other flow categories flow into an activity and between activities to serve as the inputs required for an activity to take place.

Construction is involves many assembly operations on-site and offsite which combine at different locations in the system. Moreover, several assembly operations become more complicated when they involve delivering products and assemblies that should be matched especially when they originate in different parts of the supply chain (Koskela 2000, Hopp and Spearman 1996, Hopp and Spearman 2008, Arbulu and Ballard 2004).

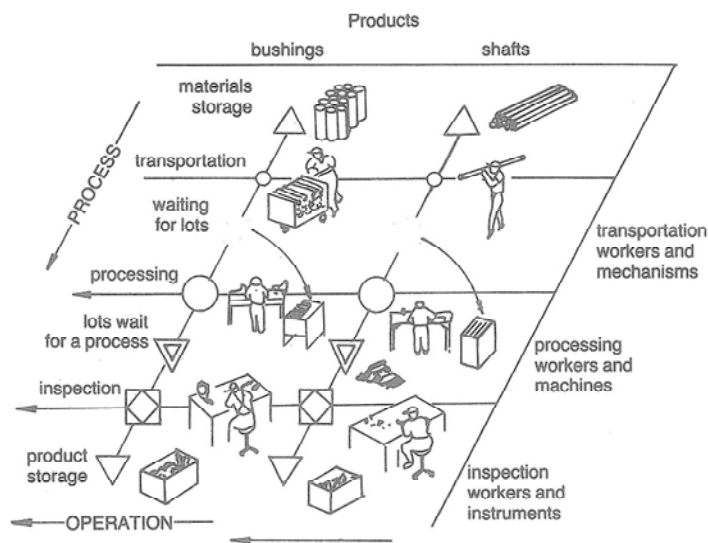

Figure 2.4: Flow of process and operations (Shingo 1988).

### 2.2.5 Variability in Systems

Variability is a characteristic of non-uniformity or unevenness. An example is variability in compressive strength of concrete cubes taken from a concrete batch. A close concept to variability is randomness which can be explained as out of control variability. In a production system, variability undermines system performance in terms of capacity, flow, duration, productivity, quality, inventory increase, customer satisfaction, etc. In general, there can be two types of variability: (1) bad variability impacting the performance of a

system and (2) good variability which is “the spice of life” such as having variable products to match different tastes (Hopp and Spearman 1996, Hopp and Spearman 2008).

In supply chain management, variability can impact both supply and demand creating a supply-demand mismatch. One way to reduce the effect of variability on production systems is using buffers of different types, such as money, time, capacity, inventory, space, and information similar to the model shown in Figure 2.5. Having huge buffers in a system is unhealthy, counterproductive, and costly. Another way to hedge against variability is by reducing lead time and process execution time. However, this may increase operation costs (Tommelein 2004, Arbulu and Ballard 2004, Ko and Ballard 2004, Hamzeh et al. 2007).

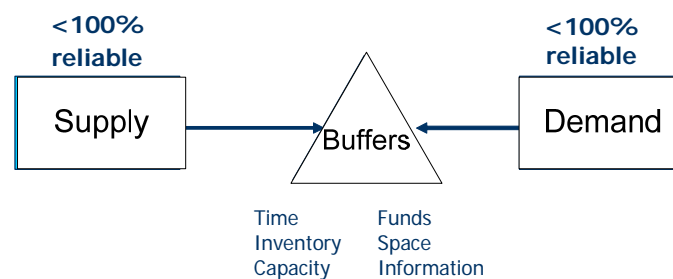

Figure 2.5: Supply-Demand mismatch.

### ***2.2.6 Variability and Waste in Construction Processes***

Researchers and practitioners emphasize the damaging effects of variability on systems’ performance in various studies and publications. Howell and Ballard’s early study (Howell and Ballard 1994a) exposes variability in input flow on construction projects, and argues for shielding production from variability in upstream flow and working in front of the shield to reduce variability.



Ballard and Howell (1998) expose the low levels of workflow reliability on construction projects, resulting from ineffective production planning and manifesting in high levels of unproductive time. They reveal a poor level of planning resource assignments, involving labor, tools, and equipment. They report that contractors complete less than 60% of weekly work assignments, and that 30% less labor is required when planning reliability reaches levels higher than 50%.

To improve the quality of planning and avoid the negative impacts of unreliable workflow, the study advocates protecting activities from variability in upstream flow; establishing appropriate buffers to cater for the remaining variability; and exercising commitment planning. Consequently, Ballard and Howell suggest implementing the LPS as a production planning and control system to increase the reliability of workflow on construction on construction projects.

Illustrating the damaging impacts of workflow variability on succeeding tasks, Tommelein et al. (1999) employ the ‘parade of trades,’ studying variability in sequential construction processes where output resources of one trade serve as input resources for the next trade. The ‘parade of trades’ highlights that variable flow generates many types of waste including: (1) lost production due to resource starvation (also leads to an increase in project duration), and (2) increase in intermediate buffers due to variability in upstream activities.

The game also shows the adverse effects variability, especially the randomness part of variability (i.e., variability in the preceding trade is different than the variability in the succeeding trade), on project durations. Starting with 5-5 dies symbolizing no variability in task durations, the project duration is expected to be 24 time units.

Increasing variability by using 3-7 dies increases the project duration to around 32 units. Increasing variation again using 1-9 dies, the project duration increases drastically to around 40 units. The study shows that wastes can be reduced and project duration shortened by reducing variability in work flow between trades. Tommelein (2003) highlights that it is not only variability in task durations that impact construction processes, but also variability in scope of work, quality, resource assignment, flow path and sequencing.

Koskela (2000) discusses the relationship between flow variability and task realization or completion. Considering a 5% uncertainty in each of the seven flows that are prerequisites to a construction task, results in a 70% chance of having that task realized. Thomas et al. 2003 and Thomas et al. 2004 study the effects of reducing variability on labor flows to improve construction performance, yet end up focusing more on increasing labor utilization rather than the value added to construction work.

Looking at variability issues from a SCM perspective, Vrijhoef and Koskela (2000) identify some major issues in construction supply chains, such as variability in deliveries, information transparency, and synchronization of material flows. They advocate reducing variability in the whole supply chain rather than just implementing buffering methods to face variability.

Variability issues are abundant in construction literature addressing work flow variability, labor flow variability, reliability of work planning, variability in productivity, variability of flows supporting a construction task, production flow variability, variability in supply chain performance, etc. In addition, various researchers highlight the implications of variability on performance, especially when production systems are

forced to employ costly buffers (money, time, capacity, inventory, space, and information) to protect production operations from destructive fluctuations (Ohno 1988, Womack et al. 1990, Ballard and Howell 1998, Tommelein et al. 1999, Koskela 2000, Vrijhoef and Koskela 2000, Hopp and Spearman 1996, Hopp and Spearman 2008, London and Kenley 2001, Elfving 2003, Thomas et. al 2003, Arbulu and Ballard 2004, Alves 2005).

On one hand, construction is plagued with flow variability issues, low transparency, adversary relationships, and fragmentation. On the other hand, construction generates a large quantity of waste of different types (section 2.4 introduces waste and waste types) (Alarcon 1993, Alarcon 1994, Serpell 1995, Alarcon 1995, Lee et al. 1999, London and Kenley 2001, and Koskela 2004).

Formoso et al. (2002) reveal higher levels of material wastes in construction than actually expected or budgeted for, and attribute a large portion of this waste to deficiencies in flow activities, such as material delivery, storage, transporting, and handling. Horman and Kenley (2005) perform a meta-analysis utilizing 24 separate studies from various countries and construction sectors, so as to estimate the level of wasted time or non-value adding time. The study results suggest 49.6% of time in construction is spent on wasteful activity.

Although the above-mentioned studies highlight crucial variability issues and expose detrimental ramifications on production systems, much is yet to be comprehended about variability. These include: the challenge of differentiating variability inherent to construction processes from random variability which appear to be out of control; sources

of flow variability; level of variability in construction flows; and mechanisms for variability reduction in construction supply chains.

Recognizing the ramifications of flow variability on construction production systems in the form of waste, inventory, lost production, excess capacity, extended durations, poor quality, and low customer satisfaction raises many concerns (Vrijhoef and Koskela 2000, Hopp and Spearman 1996, Hopp and Spearman 2008, London and Kenley 2001, Green et al. 2005, Alves 2005). These concerns trigger a quest to investigate the sources of variability in flows, ways to reduce variability, and improving the reliability of production planning.

### ***2.2.7 Characterizing Flow Variability in Manufacturing***

In a manufacturing production setting, Hopp and Spearman (2008) explain how variability at one station affects the behavior of downstream stations. They call it flow variability where flow here refers to products moving from one station to another. Figure 2.6 illustrates the variability of flow between work stations.

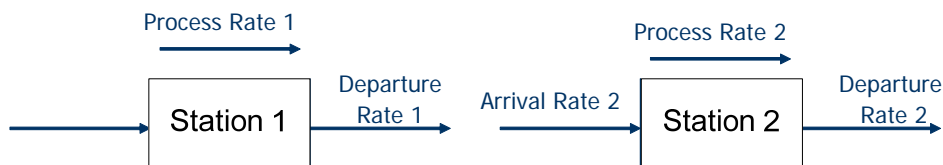

Figure 2.6: Flow variability between stations (after Hopp and Spearman 2008).

Products arrive to station 1 at a certain rate of arrival. Departures from station 1 constitute the arrivals for station 2. However, the rate of departures from station 1 depends on the rate of arrival to station 1 and the process rate or capacity of station 1. Intuitively, the capacity should be higher than the rate of arrival to avoid overloading. In Table 2.1,

arrival rates are considered having low, medium, or high variability based on the coefficient of variation, defined as the standard deviation divided by the mean.

Table 2.1: Classification of flow variability (after Hopp and Spearman 2008)

Classification of Flow Variability	Coefficient of Variation (CV)
Low variability	$CV \leq 0.75$
Medium variability	$0.75 < CV \leq 1.33$
High variability	$CV > 1.33$

Variability of departures from station 1 depends on both variability in arrivals to station 1 and variability in the process time 1. The weight of each factor depends on the utilization of the station. The utilization rate increases as the arrival rate and the average process time increases. When the utilization rate is close to 100%, inter-departure times from a station are approximately equal to the process time; and thus the coefficient of variation of departure is approximately equal to that of the process time. However, when the utilization rate is close to 0%, the station is waiting for a product to process. This results in inter-departure times from a station approximately to be equal to the arrival time, making the coefficient of variation of departure approximately equal to that of the arrival.

Arrival rate to a station and process rate dictate the level of products waiting in queue. However, in a queuing system, many resources can wait (e.g., stations, transport equipment, operators, etc.). Queuing theory is one of the approaches normally used to describe operations and status of queues in a queuing system. A queuing system faces the same processes mentioned before: arrival, processing, in addition to queuing. Products arrive to a station individually in batches. Inter arrival times can be constant or random. A station may contain a single or several machines in parallel and can have constant or random process times (Hopp and Spearman 1996, Hopp and Spearman 2008).

Regardless of how variability is characterized (e.g., parade of trades, queuing theory), production systems should employ methods to reduce and absorb variability.

### **2.2.8 Buffers**

In addition to reducing variability, buffer sizing and location can be used to manage variability in production systems. Buffers are normally used as cushions, padding activities against variability and disruptions. Although the lean ideal is to have no buffers, they are actually helpful in protecting production from the harmful consequences of variability, such as lost production throughput, wasted capacity, increased cycle times, high levels of inventory, long lead times, poor quality, and unhappy customers (Hopp and Spearman 1996, Hopp and Spearman 2008, Tommelein and Weissenberger 1999, Tommelein 2003, and Alves 2005).

Ideally, a system should run evenly without the need of buffers. However, buffers are necessary to guarantee continuous production during fluctuations. Apologists of high performance systems advocate buffer reduction as a way to decrease loads on a system, attack wastes, and increase value. But, since variability is endemic to construction activities it is crucial to learn how to recognize, manage, and reduce variability before attempting a reduction in buffers. Strategically introducing buffers in certain locations of the production system is required to cater for variability. The main types of buffers used are inventory, time, and capacity buffers (Tommelein and Weissenberger 1999, Horman and Thomas 2005, Alves 2005).

Inventory buffers can be in the form of raw materials, components, work-in-process and finished goods. Inventory is held for various reasons such as: economies of scale, variability, speculation, smoothing, logistics etc (Nahmias 2009). Howell and

Ballard (1994a) notice a high level of buffers in engineering, fabrication, and installation of pipes on a construction project where the high level of inventories accumulated do not help in increasing work flow reliability. Tommelein and Weissenberger (1999) report a heavy use of inventory buffers in a structural steel supply and construction process without necessarily improving performance. An alternative way of improving work flow reliability, Ballard and Howell (1998) advocate shielding production from variability through reliable planning using the LPS.

Time buffers are used by padding activity duration with a time cushion to cater for variability affecting task durations. Ballard (2000) recommends avoiding padding activity durations, and consciously assigning time buffers to critical and variable tasks. It is worth highlighting that float used in CPM schedules is one type of time buffers sometimes built into the schedule for future use (Alves 2005).

Capacity buffers are formed by setting aside extra capacity to be used when needed. Thus, they provide production systems with flexibility to absorb variability. Capacity buffers can be created by utilizing: overtime, increasing shifts, keeping extra resources (e.g., manpower, equipment, space, information etc), outsourcing fractions of the work, and product/process redesign to reduce the need for resources (Nahmias 2009, Alves 2005, Horman and Thomas 2005).

In summary, an appropriate assignment and location of buffers can help a production system maintain production and minimize the effects of variability. However, buffer sizing should take into account upstream players and downstream customers. Vrijoef and Koskela (2000) emphasize the impracticality of improving supply chain

reliability through buffering. Yet they do so without considering performance of the entire supply chain and without aiming to reduce variability.

### ***2.2.9 Push-Pull Systems***

The relationship between variability in a production system and the system strategy implemented is crucial in understanding system design and execution. Three strategies are normally employed: push, pull and a combination of both (Simchi-Levi et al. 2003).

In a push system, planned production is based on demand predictions. In a manufacturing push system, decisions are made centrally such as when using Material Requirement Planning (MRP) (Nahmias 2009). In construction, to finish activities as soon as possible entails a lot of push and, in fact, does not guarantee a timely completion of the project. Push systems usually capitalize on economies of scale and are ideal for systems involving long lead times. However, push systems have low flexibility, entail high inventory levels, and have the tendency to increase the amount of waste (Tommelein and Weissenberger 1999, Simchi-Levi et al. 2003).

Pull systems are demand driven; they respond to customer demand unlike push systems which depend on forecast demand. Pull systems are closely associated with JIT which was first adopted by Toyota. The philosophy behind JIT transcends the salient goal on reducing inventories to include: establishing relationships with suppliers; providing close monitoring of quality; and producing products only when needed. (Nahmias 2009)

JIT is based on two key developments introduced by Toyota: “Kanban” and “Single Minute Exchange of Dies” (SMED) (Nahmias 2009). Ohno (1988) explains Kanban as cards carrying three types of information: pickup, transfer, and production information. These cards constrain Work in Progress (WIP) in the system, reduce cycle



time, and form a sequential production system with blocking (Tommelein and Weissenberger 1999, Hopp and Spearman 2004). SMED, the creation of Shingeo Shingo, is the basis for the relentless efforts by Toyota to reduce setup times (Shingo 1988).

Pull systems employing JIT have many advantages, including: (1) reducing WIP and cycle time; (2) smoothing production flow by reducing fluctuations in WIP level; (3) improving quality by shrinking the time between the inception and detection of a defect; and (4) reducing inventory costs. However, other ways to reduce inventory costs are also in use, such as fixing the level of WIP inventory using what is called a CONWIP strategy, or constant WIP (Hopp and Spearman 2004, Nahmias 2009).

Although pull systems and underlying JIT are widely promoted in the construction industry, they are only suitable under certain conditions such as stable demand and short lead times. However, since the sources of variability can never be eliminated and some lead times are difficult to reduce, employing pull cannot be the right strategy for all production systems (Nahmias 2009).

Push-Pull systems or more correctly pull-push systems combine both pull and push strategies and apply them in different locations of a supply chain. In general, push is employed in the initial stages of a supply chain involving a lot of aggregation and building materials to-stock based on forecasts. The last part of the supply chain closer to the customer is operated in a pull manner where products are built to-order in response to customer demand (Simchi-Levi et al. 2003). Tommelein (1998) presents an industry example of push-pull systems. In summary, production systems employ various techniques to forecast, absorb, and reduce variability.

## **2.3 Supply Chain Management and Logistics**

### ***2.3.1 Supply Chain Management***

A supply chain is defined as a network of companies exchanging materials, services, information and funds with each other to satisfy end user needs. Definitions of supply chain management are abundant in the literature but mainly focus on the following key attributes: (a) a collaborative relationship between supply chain firms pursuing global optimization goals by joint planning, management, implementation and control of operations; (b) an interdependence among firms requiring holistic analysis of tradeoffs shaping the performance of the whole chain; and (c) a quest towards customer satisfaction that translates into benefits for the whole network (Bowersox et al. 2007, Ayers 2006, Tommelein et al. 2003, and Simchi-Levi et al. 2003).

The following definition, encompassing the above mentioned functions, will be used in this dissertation: Supply chain management involves firms working collaboratively designing and operating a network of interrelated processes to achieve global goals, such as reducing total costs, decreasing total lead times, or improving total profits in a holistic tradeoff context while meeting customer value and rewarding all members of the chain (Tommelein et al. 2003, Ayers 2006, and Hamzeh et al. 2007).

### ***2.3.2 Logistics***

By moving materials, services, funds, and information up and down the supply chain, ‘logistics’ ensures delivery of the right products and services in the right quantities to the right customers at the right time while minimizing costs. Some of the key logistics functions are: managing customer service, orders, inventory, transportation, storage,

handling, packaging, information, forecasting, production planning, purchasing, cross docking, repackaging, preassembly, facility location and distribution (Christopher 1998, Simchi-Levi et al. 2003, Gourdin 2006, Bowersox et al. 2007, and Hamzeh et al. 2007).

### **2.3.3 *Supply Chain Management versus Logistics***

While some authors consider *supply chain management* and *logistics* as interchangeable terms, others draw a clear differentiation in the way the functions are defined. Ayers (2006) suggests that “supply chain management is a broader term than its component functions such as logistics, manufacturing, and procurement.” This goes in line with the definition of logistics suggested by Baudin: “Logistics is comprised of all the operations needed to deliver goods or services, except making the goods or performing the services” (Baudin 2004). Although many definitions favor a broader scope of supply chain management than merely logistics, SCM and logistics can mean the same or different things, simply depending on the way they are defined.

## **2.4 Waste**

*Toyota Production System* (TPS) highlights three contributors to waste in production: *Muda* (non-value added), *Muri* (overburdening people or equipment), and *Mura* (unevenness) (Ohno 1988, Liker 2004, and Womack 2006).

Ohno (1988) defines *Muda* as, “all elements of production that only increases cost without adding value.” Ohno identified seven types of *Muda*: overproduction, waiting, unnecessary transport or conveyance, over-processing or incorrect processing, excess stock/ inventory, unnecessary movement, and defects. Many scholars later suggested additional types of waste: Womack and Jones (2003) proffered “design that does not

meet user's needs;" Liker (2004) considered "unused employee talent;" Koskela (2004) proposed "making-do" (starting an activity before prerequisites are ready); and others recognized "excess information" as an eighth type.

*Muri-overloading people and equipment*, called unreasonableness by Ohno (1988), is driving humans and equipment beyond natural thresholds. It can lead to safety issues, quality problems and breakdowns which may result in increasing *Muda*. Kitano (1997) suggests avoiding *Muri* proactively by using proper process planning.

*Mura-unevenness or inconsistency* is due to fluctuations at the operations level resulting from internal factors (such as downtime or unbalanced loads) or from external factors (such as meeting a highly variable demand or preset financial milestones) (Liker 2004 and Womack 2006).

Mura, Muri and Muda are very closely intertwined in production: unevenness of production (Mura) often leads to overburdening of people and machines (Muri) causing breakdowns, defects and other non-value adding consequences that fall under (Muda) (Womack 2006). Kitano (1997) proposes examination and deeper understanding of Muda by recognizing the connections between Muda and Mura. This information should be used in a feedback loop used in future planning to control the levels of Muri.

## **2.5 Planning and Scheduling in Uncertain Environments**

When considering the design and execution of a production system, planning should not be overlooked. Most often the focus is on the plan and not the planning process. However, it is planning that matters not just the plan as General Eisenhower states "*Plans are worthless. Planning is essential*".

Planning is understood as the process of defining goals, developing strategies, and utilizing tasks, schedules and resources to attain them. Scheduling is the process of building a time based graphical representation of the desired goals describing task duration, resources, time constraints, and CPM (Critical Path Method)-based time calculations (Daft 1991, Smith 2003, and Hinze 2008).

The planning process should not be judged only by the outcome deliverable such schedule, estimate, or strategic plan. Planning is a continuous adaptive iterative process in quest for value. The best results are achieved in a collaborative and fully-democratic fashion. Accordingly, successful planning is expected to: (1) reduce risk, (2) manage and reduce uncertainty, (3) support sound decision making, (4) establish trust, and (5) share information (Cohn 2006).

Given the uncertain and sometimes unpredictable environment of project execution, the scheduling process should be dynamic and iterative rather than static and deterministic. If the goal of scheduling is to optimize performance of a system with limited resources over a period of time, then the schedule should be continuously relevant to current environment of the system. While a few system environments are stable and static, most environments are highly unpredictable and dynamic. As a result, advance optimized schedules are only suited for the stable environments (Smith 2003).

In uncertain and dynamic environments, advance schedules have a short life time; and hence, scheduling should be a continuous process responding to changing circumstances. A suggested approach for improved project execution in uncertain environments is to incorporate some flexibility in schedules to cater for uncertainty (Smith 2003).

However, the scheduling process can be plagued by various problems. Scheduling involves forecasts that can be more wrong and inaccurate the more detailed a forecast is and the further it projects into the future (Nahmias 2009). As mentioned in Chapter 1, plans on many construction projects that are developed and pushed from the top are very hard to execute by those on the frontline. In fact, plans that are not developed without involving those who are doing the work (e.g., blue collar workers) are not often difficult to execute. However, a well developed plan is also doomed for failure if prerequisites are not made ready for work to take place as planned. Moreover, production plans developed on the basis of wishful thinking and in absence of reliable promises are more likely to fall short during execution. If causes of plan failures are not identified and dealt with, failures are bound to recur.

Answering the above-mentioned concerns requires a holistic approach to construction production systems, taking into account outputs and inputs, expectations and results, processes and operations, system design and execution, etc. However, this study tackles these issues by improving the reliability of production flow through improved weekly work planning and lookahead planning. This improvement will have three major implications: (1) increases percent plan complete (PPC) which is a measure of reliable weekly work planning, (2) improves productivity as a result of reliable workflow and focusing crew efforts on ready tasks, and (3) links weekly production to global project milestones, increasing the ability of (PPC) to represent overall project's progress.

Although the LPS has been successfully implemented on construction projects, the current practice still shows many deficiencies. Many of these deficiencies are mainly related to how practitioners are using the system. LPS related deficiencies are mainly

related to the lookahead planning process which was developed but not fully articulated. An example of current practice deficiencies is the wide gap between long-term planning (master schedules) and short-term planning (commitment/weekly work plan) which results from poor lookahead planning. The wider this gap is, the farther the weekly plan is from executing activities that count towards achieving milestones; and consequently, the lower is the ability of percent Plan complete (PPC) to indicate project progress. Accordingly, this research addresses issue by examining the current practice and suggesting guidelines for lookahead planning. Chapter 3, 5 and 6 explain the deficiencies in further detail and present improvement methods.

## 2.6 References

- Alarcón, L. F. (1993). "Modeling Waste and Performance in Construction." Proceedings of the 1st Annual Conference of the International Group for Lean Construction, Espoo, Finland.
- Alarcón, L. F. (1994). "Tools for Identification and Reduction of Waste in Construction Projects." *Proceedings of the 2nd Annual Conference of the International Group for Lean Construction, IGLC 2*, 28-30 September, Santiago, Chile.
- Alarcón, L. F. (1995). "Training field personnel to identify waste and improvement opportunities in construction." *Proceedings of the 3rd Annual Conference of the International Group for Lean Construction*, Albuquerque, N.M.
- Alves, T.C.L. (2005) *Buffering Practices in HVAC Supply Chains*. Ph.D. Dissertation- Civil and Environmental Engineering, University of California, Berkeley, U.S.A.
- Arbulu, R., and Ballard, G. (2004). "Lean Supply Systems in Construction". *12th International Group for Lean Construction Conference*, Elsinore, Denmark.
- Ayers, J.B. (2006). *Handbook of Supply Chain Management*. 2<sup>nd</sup> Edition, Auerbach Publications, Boca Raton, FL, 608 pp.
- Ballard, G. (2000a). *The Last Planner System of Production Control*. Ph.D. Thesis, Faculty of Engineering, School of Civil Engineering, The University of Birmingham.

- Ballard, G., and Howell, G. (1998). "Shielding Production: An Essential Step in Production Control", *Journal of Construction Engineering and Management*, ASCE, 124 (1), pp. 11-17.
- Ballard, G., and Howell, G. (2003). "Competing Construction Management Paradigms". Proceeding of *Construction Research Congress, Winds of Change: Integration and Innovation in Construction*, HI, U.S.A., pp. 321-328.
- Ballard, G., Kim, Y.W., Jang, J.W., and Liu, M. (2007). *Road Map for Lean Implementation at the Project Level, Research Report 234-11*, Construction Industry Institute, The University of Texas at Austin, Texas, USA, 426 pp.
- Ballard, G., Koskela, L., Howell, G., and Zabelle, T. (2001). "Production system design: Work structuring revisited." *White Paper-11*, Lean Construction Institute, Ketchum, Id.
- Ballard, G., Tommelein, I. D., Koskela, L., and Howell, G. (2003). *Lean Construction Tools and Techniques (Chapter 15) of Design and Construction: Building in Value*, Butterworth Heinemann, pp. 227-255.
- Baudin M. (2004). *Lean Logistics - The Nuts and Bolts of Delivering Materials and Goods*, Productivity Press, New York, NY, 387 pp.
- Bowersox, D.J., Closs, D.J., and Cooper, M.B. (2007). *Supply Chain Logistics Management*. Second Edition, McGraw-Hill/Irwin, NY, 410 pp.
- Cohn, M. (2006). *Agile Estimating and Planning*, Prentice Hall Professional Technical Reference, Upper Saddle River, New Jersey, 330 pp.
- Daft, R. (1991). *Management*. Dryden Press, Chicago, 744 pp.
- Elfving, J.A. (2003) *Application of Lean Methods in Reducing Lead Times for Engineered-To-Order Products*. Ph.D. Dissertation- Civil and Environmental Engineering, University of California, Berkeley, U.S.A.
- Elfving, J.A., and Tommelein, I.D. (2003) "Construction engineering and project management II: impact of multitasking and merge bias on procurement of complex equipment", *Winter Simulation Conference 2003*, pp. 1527-1533.
- Formoso, C.T., Soibelman, L., De Cesare, C., and Isatto, E.L. (2002)"Material Waste in Building Industry: Main Causes and Prevention", *Journal of Construction Engineering and Management*, July/August, pp. 316- 325.



- Gilbreth, F.B., and Gilbreth, L.M. (1922) "Process Charts and Their Place in Management." *Mechanical Engineering*, January, pp. 38-41.
- Gourdin, K.N. (2006). *Global Logistics Management: A Competitive Advantage for the 21st Century*, Second Edition, Blackwell Publishers, Malden, MA, 318 pp.
- Green, S.D., Fernie, S., and Weller, S. (2005) "Making Sense of Supply Chain Management: A Comparative Study of Aerospace and Construction". *Construction Management and Economics*, July, pp. 579-593.
- Hamzeh, F.R., Tommelein, I.D., Ballard, G., and Kaminsky, P. (2007). "Logistics Centers to Support Project-Based Production in the Construction Industry", *Proceedings of the 15th Annual Conference of the International Group for Lean Construction, IGLC 15*, 18-20 July, East Lansing, Michigan, USA, pp. 181-191.
- Hinze, J.W. (2008). *Construction Planning and Scheduling*. Pearson Prentice Hall, Upper Saddle River, New Jersey, 374 pp.
- Horman, M. J., and Kenley, R. (2005). "Quantifying Levels of Wasted Time in Construction with Meta-Analysis", *Journal of Construction Engineering and Management*, ASCE, Jan., pp. 52-61.
- Horman, M. J., and Thomas, R. (2005). "Role of Inventory Buffers in Construction Labor Performance," *Journal of Construction Engineering and Management*, ASCE, July, pp. 834-843.
- Hopp, W.J., and Spearman, M.L. (2004). "To Pull or not to Pull: What is the Question?" *Manufacturing & Service Operations Management*, Volume 6, Issue 2, pp. 133-148.
- Hopp, W.J., and Spearman, M.L. (1996). *Factory Physics*, 1<sup>st</sup> Ed., Irwin, Chicago, 668 pp.
- Hopp, W.J., and Spearman, M.L. (2008). *Factory Physics*, 3<sup>rd</sup> Ed., Irwin/ McGraw-Hill, Boston, 720 pp.
- Howell, G. A. and Ballard, G., (1994a). "Implementing Lean Construction: Reducing Inflow Variation", *Proceedings of the 2nd Annual Conference of the International Group for Lean Construction, IGLC 2*, 28-30 September, Santiago, Chile.
- Howell, G. A. and Ballard, G., (1994b). "Lean Production Theory: Moving Beyond Can-Do", *Proceedings of the 2nd Annual Conference of the International Group for Lean Construction, IGLC 2*, 28-30 September, Santiago, Chile.

- Kitano, M. (1997) "Toyota Production System 'One-by-One Confirmation'," *Lean Manufacturing Conference*, keynote address, University of Kentucky, May-14-16, <http://www.mfgeng.com/images/toyota.pdf>
- Ko, C.H. and Ballard, G. (2004). "Demand Variability and Fabrication Lead Time: Descriptive Research, Phase I." Technical Report, University of California at Berkeley, Berkeley, CA.
- Koskela, L. (1992). *Application of the New Production Philosophy to Construction*. Stanford University, CIFE technical report #72, 87 pp.
- Koskela, L. (2000). An exploration towards a production theory and its application construction. PhD Dissertation, University of Technology, Espoo-Finland.
- Koskela, L. (2004). "Making-Do - The Eighth Category of Waste", Proceedings of the 12th International Group for Lean Construction Conference, Denmark.
- Laseter, T. and Oliver, K. (2003). "When Will Supply Chain Management Grow Up?" *Strategy + Business*, Issue 32, Fall 2003: <http://www.strategy-business.com/media/file/03304.pdf>
- Lee, S., Diekmann, J.E., Songer, A.D., and Brown, H. (1999). "Identifying Waste: Applications of Construction Process Analysis." *Proceedings of the 7th International Group for Lean Construction Conference*, Berkeley, CA, USA.
- Liker, J.K. (2004). *The Toyota Way- 14 Management Principles from the World's Greatest Manufacturer*, McGraw Hill, NY, 330 pp.
- London, K.A., and Kenley, R. (2001). "An Industrial Organization Economic supply chain approach for the construction industry: a Review", *Construction Management and Economics*, 19, pp. 777-788.
- Metcalf, L. (2004). "Supply Chains- An Introduction", *Chartered Accountant Journal*, May, pp. 55-57.
- Miles, R. E., and Snow, C.C. (2007). "Organization Theory and Supply Chain Management: An Evolving Research Perspective," *Journal of Operations Management*, 25, pp. 459-463.
- Nahmias, S. (2009) *Production and Operations Analysis*. 6<sup>th</sup> edition, McGraw Hill/Irwin, NY, 789 pp.

- Ohno, T. (1988). *Toyota Production System- Beyond Large-Scale Production*. Productivity Press, Cambridge, MA, 143 pp.
- Riley, D.R., and Tommelein, I.D. (1996). "Space planning tools for multi-story construction", *Computing in Civil Engineering*, New York, pp. 718-724.
- Serpell, A., Venturi, A., and Contreras, J. (1995). "Characterization of waste in building construction projects." *Proceedings of the 3rd Annual Conference of the International Group for Lean Construction*, Albuquerque, N.M.
- Shingo, S. (1981). *Study of 'Toyota' Production System from Industrial Engineering Viewpoint*. Japan Management Association, Tokyo, Japan, 363 pp.
- Shingo, S. (1988). *Non- Stock production: The Shingo System for continuous improvement*. Productivity Press, Cambridge, MA, 454 pp.
- Simchi-Levi D., Kaminsky P., and Simchi-Levi E. (2003). *Designing and Managing the Supply Chain*, second edition, McGraw-Hill Irwin, 354 pp.
- Smith, S.F. (2003). "Is Scheduling a Solved Problem?", *Proceedings of the First Multi-Disciplinary International Conference on Scheduling: Theory and Applications (MISTA 03)*, August, Nottingham, UK, 16 pp.
- Thomas, H. R., Horman, J. H., Minchin R. E., and Chen, D. (2003). "Improving Labor Flow Reliability for Better Productivity as Lean Construction Principle," *Journal of Construction Engineering and Management*, ASCE, May/June, pp. 251-261.
- Thomas, H. R., Horman, J. H., Minchin R. E., and Souza, U.E.L. (2004). "Symbiotic Crew Relationships and Labor Flow," *Journal of Construction Engineering and Management*, ASCE, Nov. /Dec., pp. 908-917.
- Tommelein, I.D. (2003). "Acknowledging Variability and Uncertainty in Product and Process Development." Chapter in Issa, R.R.A., Flood, I., and O'Brien, W.J. (editors) *4D CAD and Visualization in Construction: Developments and Applications*, A.A. Balkema Publishers, pp. 165-193.
- Tommelein, I.D. (2004). *The Value Chain: Adding Value to the Supply Chain*, Mechanical Contracting Education & Research Foundation (MCERF), Chantilly, VA.
- Tommelein, I.D. (2006). *Advanced Construction Engineering - Lean Construction*. Graduate Course. Course Documents, University of California, Berkeley.

- Tommelein, I.D., Ballard, G., and Kaminsky, P. (2009). "Supply Chain Management for Lean Project Delivery." Chapter 6 in O'Brien, W.J., Formoso, C.T., Vrijhoef, R., and London, K.A. (eds.) *Construction Supply Chain Management Handbook*. CRC Press, Taylor & Francis Group, Boca Raton, FL.
- Tommelein, I.D., Riley, D.R., and Howell, G.A. (1999). "Parade Game: Impact of Work Flow Variability on Trade Performance." *Journal of Construction Engineering and Management*, ASCE, Sep. /Oct., pp. 304-310.
- Tommelein, I.D., Walsh, K.D., and Hershauer, J.C. (2003). "Improving Capital Projects Supply Chain Performance." *Research Report PT172-11*, Construction Industry Institute, Austin, TX, 241 pp.
- Tommelein, I.D., and Weissenberger, M. (1999). "More Just-In-Time: Location of Buffers in Structural Steel Supply and Construction Processes," *Proceedings of the 7th International Group for Lean Construction Conference*, Berkeley, CA, USA.
- Tsao, C.C.Y., Tommelein, I.D., Swanlund, E.S., and Howell, G.A. (2004). "Work Structuring to Achieve Integrated Product-Process Design", *Journal of Construction Engineering and Management*, 130(6), pp. 780-789.
- Vrijhoef, R., Koskela, L. (1999). "Roles of Supply Chain Management in Construction", *Proceedings of the Seventh Annual Conference of the International Group for Lean Construction IGLC-7 Berkeley*, July 26-28, pp. 133-146.
- Vrijhoef, R., Koskela, L. (2000). "The Four Roles of Supply Chain Management in Construction", *European Journal of Purchasing & Supply Management*,(6), pp. 169-178.
- Womack, J.P., Jones, D.T., and Roos, D. (1990). *The Machine that Changed the World*. Harper-Collins, NY, 323 pp.
- Womack, J.P., and Jones, D.T. (2003) *Lean Thinking: Banish Waste and Create Wealth in Your Corporation*, Simon & Schuster, New York, 396 pp.
- Womack, J.P. (2006). "Mura, Muri, Muda? *Jim Womack E-letter*", 07 July, [http://www.leanuk.org/articles/mura\\_muri\\_muda.pdf](http://www.leanuk.org/articles/mura_muri_muda.pdf), last accessed November 12, 2007.

## ***CHAPTER 3 - PRIMARY CASE STUDY - CATHEDRAL HILL HOSPITAL PROJECT***

This chapter presents research results from the Cathedral Hill Hospital (CHH) project. It reports on the implementation process of the Last Planner System™ (LPS) at CHH as a reference case study for good industry practices and a benchmark for continuous improvement. The planning processes applied on this project support the case for implementing the LPS in construction and specifically during design. The chapter presents a hands-on application of the suggested production planning and control model discussed in detail in chapter 5. It supports the argument advanced throughout this dissertation confirming the importance of lookahead planning as an intermediate planning process bridging the gap between master scheduling and weekly work planning.

The chapter begins with an overall description of the project, followed by a description and critique of the planning process initially found on the project. Later sections portray the design and implementation of a new process. The chapter ends with implementation challenges and case study conclusions.

### **3.1 Project Background**

#### ***3.1.1 Case Study Selection***

CHH is a unique project to study for many reasons including: (1) implementing integrated project delivery (IPD) and integrated form of agreement (IFOA), (2) engaging project partners who are interested in experimenting with lean practices, (3) applying the

LPS for production control, (4) utilizing target value design (TVD) to steer design towards meeting the owner's value proposition, (5) and using building information modeling (BIM) extensively.

Research on this project was performed in an "action research" environment where the author joined the project as a team member, gathered empirical data, analyzed and evaluated the data with the team, searched for patterns or variations, developed various improvement alternatives, and tested these improvements empirically.

Although this case study epitomizes advanced industry practices for implementing the LPS during design, results of this study cannot be simply generalized to cover all construction projects.

### ***3.1.2 Project Scope***

CHH project is a proposed 555-bed hospital and medical campus at Geary Boulevard and Van Ness Avenue in San Francisco, California. The California Pacific Medical Center's (CPMC) \$1.7 billion project includes a 16-story hospital including two below grade floors. Design started in 2005, underwent several changes, and was validated in 2007. Design validation confirmed the project's ability to meet the owner's value proposition in terms of function, cost, and operation. The hospital is intended to begin operations on January 1<sup>st</sup> 2015.

The project's owner, CPMC, an affiliate of Sutter Health, has worked closely with the community and the unions to address the city's concerns and to make the project a reality. Sutter Health, one of three large healthcare providers in northern California, has been a strong advocate of lean practices and a firm believer in IPD for healthcare facility design and construction (Lichtig 2006).

The CHH project was accepted for phased plan review (PPR) by the Office of Statewide Health Planning and Development (OSHPD). This process engages OSHPD in reviewing design in a phased manner during the different stages of the project namely: conceptualization, criteria design, detailed design, implementation documents, agency review, construction, and closeout (OSHPD 2008). The project parties negotiated and established with OSHPD milestones for the completion of each phase.

### ***3.1.3 Integrated Project Delivery Team***

CPMC assembled a preconstruction team to validate the project business case, collaborate during design development, and lead the project into the construction phase. The owner opted for an IFOA and an IPD to align stakeholder interests, improve project performance, share risks and rewards, and maximize value for designers, builders, owner, and users (Lichtig 2005 and 2006). At the beginning of the project, the owner (CPMC and Sutter Health), the architect (Smith Group), and CM/GC (Herrero-Boldt) signed the agreement. Other project parties subsequently signed the agreement when joining the project.

The IPD team assembled for the validation phase included: the owner, healthcare providers, operations staff, architects, engineers, specialty consultants, suppliers, the general contractor, and major sub-contractors called ‘trade partners’ as per the project agreement. Cross-functional teams called ‘clusters’ involving specialists from various organizations having different design and construction backgrounds were established as the organizational units for both design and validation. Clusters included: Structural, Mechanical Electrical Plumbing (MEP), External Enclosure, Interiors, Equipment, Entitlements, Production, Technology, Vertical Transportation, and Sustainability. Each

cluster functions as an independent unit, yet collaborates with other clusters. A Core Group cluster comprising top executives from owner architect, and construction manager / general contractor was responsible for making major decisions on the project.

To maximize value delivered on this project and continuously reduce waste, IPD and IFOA were adopted in conjunction with Sutter's "Five Big Ideas" that emphasize: (1) increasing the relatedness among IPD team members, (2) improving collaboration between project parties during all project phases, (3) managing the project as a network of interrelated commitments, (4) looking beyond local optimization to optimizing the whole, and (5) promoting organizational learning from the collective experience to drive continuous improvement (IFOA 2007).

The IPD team performed a design validation study from March 26<sup>th</sup> 2007 to July 31<sup>st</sup> 2007 investigating project feasibility and confirming the project's ability to: (1) satisfy the owner's value proposition, (2) deliver the required services, (3) meet the schedule, and (4) fall within budget. Moreover, the validation study confirmed the benefits of using lean construction principles to meet the project objectives (Validation report 2007).

As a production planning and control system, the LPS was implemented at the owner's request to include the following: "a milestone schedule, collaboratively created phase schedules, 'make-ready' lookahead plans, weekly work plans, and a method for measuring, recording, and improving planning reliability" (IFOA 2007).

Project parties have committed themselves to exercising 'reliable promising' in planning and executing work on the project. Reliable promising is the process for preparing, making, and executing commitments. Commitments start by a request which is



then analyzed. After clarifications and negotiations, a commitment is made or the request is denied because the promise cannot be reliably kept. Declaring completion signals an acceptable performance in meeting the conditions of satisfaction requested in the first step (Flores 1982, Ballard et al. (1999a), Ballard et al. (1999b), Macomber and Howell 2003, Macomber 2003, Ballard and Hamzeh 2007).

Reliable promising requires, among other things, a clear communication of the conditions of satisfaction between the performer and the customer. The performer has to apply quality criteria to promised tasks (definition, soundness, size, sequence, and learning). Accordingly, the performer should be sincere when making a promise or a commitment and should accept consequences for breaking a promise or a commitment (IFOA 2007).

## **3.2 The Old Planning Process**

Research on this project started in January 2008 investigating current planning processes in general and the implementation of the LPS in particular. Research comprised the following activities: (1) observing the current planning processes, (2) collecting comments on the current processes, and (3) suggesting a new model for production planning and control. This section describes the old planning process and the team's performance on each planning tier of the LPS (i.e., Master Scheduling, Phase Scheduling, Lookahead Planning, and Weekly Work Planning).

### **3.2.1 *Master Scheduling***

By June 27<sup>th</sup> 2007, the IPD team had collaboratively developed a baseline master schedule incorporating input from project stakeholders who participated in the design

validation study as summarized in table 3.1. This schedule shows March 26<sup>th</sup> 2007 as the start date and December 21<sup>st</sup> 2014 as the end date. Major project milestones include: (1) the start of abatement on October 8<sup>th</sup> 2009, (2) submission of construction documents to OSHPD on January 1<sup>st</sup> 2009, (3) obtaining OSHPD permit on January 1<sup>st</sup> 2011, (4) start of structural steel erection on May 17<sup>th</sup> 2011, (4) receiving occupancy permit from OSHPD on September 25<sup>th</sup> 2003, and (5) meeting compliance deadline by January 1<sup>st</sup> 2015.

Table 3.1: Project stakeholders participating in the design validation study

Project Stakeholder	Discipline/Specialty
CPMC/Sutter Health	Owner
Smith Group	Architect/Engineer
Herrero-Boldt	Construction Manager/General Contractor
Degenkolb	Structural Engineer
The Marchese Company	Entitlements
Pankow Builders	Concrete Structures Contractor
Ted Jacob Engineering Group	Mechanical Engineer
Southland Industries	Mechanical Contractor
Rosendin Electric	Electrical Contractor
Silverman and Light	Electrical Engineer
Vantage Technology Consulting Group	Info. Technology & Audio Visual Consultant
On-line Consulting Services	Security Consultant
Syska & Hennessey	Elevator Consultant
Marshall Associates	Food Service Consultant
The Schachinger Group	Equipment Consultant
Navigant	Operations Consultant
Ghafari	Building Information Modeling Consultant
Rolf Jensen Associates	Fire Protection Consultant

Lombardia Consulting, a company specialized in scheduling consultancy services, was assigned to assist the project team develop a more comprehensive schedule based on the baseline master schedule. Building further detail into the schedule required organizing several planning sessions with project partners. Lombardia Consulting was in charge of updating the resulting master schedule on a monthly basis (on average) and appending

new detailed schedule fragments as soon as new project partners join the project, such as the drywall trade partner or the curtain wall trade partner.

The team used Primavera's P3 and P6 software packages to build the master schedule on this project. While P3 has been on the market in windows version since 1994 and is considered a stable version for building and updating schedules, the same is not said of P6 that has caused operational issues for planners (e.g., presentation and format). While P6 is now a part of an enterprise portfolio management package administered by Oracle, a feature I have heard planners request is allowing more user-friendly participation of all project last planners (e.g., team leaders, foremen, and superintendents) and not just of schedulers or project managers.

### ***3.2.2 Phase Scheduling***

Phase scheduling is a collaborative planning process, where the team: (1) defines a project phase or milestone, (2) breaks it down into constituent activities, and (3) schedules activities backward from the milestone. After incorporating input from different project partners and identifying hand-offs between specialists, the team performs reverse phase scheduling back from important phase milestones.

The team organized various phase scheduling meetings or pull sessions during the validation phase but did not incorporate results from these sessions into schedules to monitor or track, except for the baseline master schedule and part of the structural package schedule. These sessions could not accomplish all the objectives of pull scheduling due to incomplete information and the high degree of uncertainty surrounding many packages. Moreover, a comprehensive pull session was not possible at that time since many trade partners had not yet been engaged.

### ***3.2.3 Lookahead Planning***

Compared to long-term planning resulting in a master or phase schedule and short-term planning resulting in weekly work plan, lookahead plans are the outcomes of mid-term planning showing activities initially at the level of processes and subsequently at the level of operations. However, lookahead plans developed by presenting a near-term view of activities on a master or phase schedule do not necessarily show details of processes or operations. Accordingly, these schedules are ‘lookahead views’ and not lookahead plans.

Initially, lookahead plans at CHH project resembled ‘lookahead views’ and were too coarse to be tracked or updated on a weekly basis. Recognizing this problem, the IPD team agreed to generate lookahead plans on a cluster-by-cluster basis. These lookahead plans are intended to connect phase scheduling to weekly work plans.

### ***3.2.4 Commitment / Weekly Work Planning***

Weekly work plans are the most detailed plans in the LPS. These plans are developed in collaborative weekly meetings where last planners representing all project stakeholders are present. Last planners are team leaders and frontline supervisors directly overlooking work execution such as team leaders overlooking design planners. The purpose of these weekly meetings is to increase plan reliability and reliable promising by making quality assignments, requests, and commitments.

The weekly work planning meetings at CHH project, which started on September 24<sup>th</sup> 2007, proved helpful in bringing last planners together to plan work for the upcoming week, discuss thorny issues, identify constraints across different trades or design clusters, and secure commitments from trade partners to remove constraints. Owner participation in these meetings was crucial for enabling plan coordination and

setting the tone for collaboration. The presence of practitioners experienced in using the LPS in these meetings enhanced coordination, communication, and problem solving. These practitioners often trained meeting attendees on various coordination mechanisms including: making quality assignments (explained in detail in section 5.4), communicating clear requests, expressing conditions of satisfaction, and exercising reliable promising.

However, like any other process, there is always room for improvement. Section 3.3.1 presents a summary of observations collected over six months of monitoring weekly work plan meetings and discussions with last planners.

### **3.3 Critique of the Old Planning Process**

I started observation and monitoring of the planning process at CHH in January 2008. Studying the current process entailed attending weekly work planning meetings and phase / pull scheduling sessions, discussing planning issues with last planners, recording observations and recommendations, mapping information flow, and mapping a new planning process.

#### ***3.3.1 Observations, Comments, and Suggestions for Improvement***

A method I employed when performing my research on CHH project is “action research” by joining the project as a team member, gathering empirical data, analyzing and evaluating data with the team, searching for patterns or variations, developing hypotheses for system improvement, and testing these hypotheses empirically.

I communicated results from my research, observations, and suggestions for improvement to the team who often endorsed improvement ideas and introduced

adjustments to the planning process or planning meeting procedures. The following is a summary of the major observations, comments, and suggestions divided into two groups: (1) comments that helped initiate process adjustments or were incorporated into the new planning process, and (2) general comments that described the process and presented general application guidelines without presenting specific recommendations.

#### *3.3.1.1 Observations and Suggestions Initiating Process Adjustments*

Table 3.2 summarizes observations and suggestions that the team adopted and incorporated into an adjusted planning process (to be discussed in detail in section 3.4.3). I have discussed these observations with the project team and together we developed improvement methods and ideas.

Table 3.2: Observations and suggestions for improvement

Observations	Suggestions for Improvement
Weekly work planning meetings involve a lot of status reporting which can take time away from team planning and decision making.	Forward updates of last week's and next week's work plan to the facilitator before the meeting. Last planners to bring up requests for commitment and be ready to make commitments.
Work schedules and coordination plans established in cluster meetings are not incorporated into the team's tracked weekly work plans.	All cluster groups to include the LPS in their meetings to perform weekly work planning, constraint removal, analysis of plan failures, and work coordination. Work plans to be coordinated with other clusters during the IPD team meeting.
Weekly work planning assignments are not properly linked to long-term milestones and goals.	Incorporate lookahead planning (6 weeks lookahead) into weekly work plan development: breaking down long-term phases and process into operations, coordinating work schedules, and identifying constraints.
Last planners do not always identify reasons for plan failure.	Incorporate root cause analysis (5 why's) into weekly work planning process.
Weekly work plans include many completed but not planned tasks. This is a sign of the planning system's inability to anticipate tasks.	Prioritize critical tasks and tasks that would release work for somebody else downstream. Improve task anticipation by breaking down processes into operations.
Many constraints that lead to failure of tasks on the weekly work plan were not easy to identify.	Perform constraint identification while breaking down processes into operations, operation design, and coordination.
The number of tasks on the weekly work plan is less than work accomplished as some assignments are not reported. PPC results are skewed due to absence of many activities that are taking place.	Clusters to prepare their weekly work plans in cluster meetings. A cluster representative would present its work plan in the IPD team meeting. Create an atmosphere to exercise reliable promising without the fear of being a scapegoat in case of a plan failure.

### 3.3.1.2 General Comments

The following general comments, presented in table 3.3, highlight some process deficiencies and general team communication imperfections. The presented guidelines for

the application may seem obvious to experienced LPS users but are intended to raise the awareness of industry practitioners to process issues that are rectifiable in a collaborative environment such as that available at CHH project.

Table 3.3: General observations and guidelines for application

General Observations	Guidelines for Application
Some weekly tasks do not match quality criteria for schedule assignments including: long task duration, incorrect time estimate, unclear task outcome, over-committing.	Improve quality of assignments by: (1) properly defining each task's beginning, end, and outcome, (2) ensuring tasks are sound or constraint-free, (3) avoiding out-of-sequence work, (4) properly matching load and capacity and sizing tasks not to span beyond the current week, and (5) using PDCA cycle and root cause analysis to continuously improve the quality of assignments.
Language employed does not always enable reliable promising especially when tasks are not defined, outcomes not specified, and conditions of satisfaction not communicated.	Last planners to make quality requests with identifiable outcomes. For example use "Provide a schedule of equipment to be used in room x" instead of "Define equipment to be used in room x". Also communicate conditions of satisfaction required such as "Provide interior layout drawings showing drywall types."
Certain decisions, constraints removal, commitments could not be made due to absence of project partners.	Involve all project stakeholders, decision makers, and team leaders.
'Incorrect time estimate' and 'I forgot' are major reasons for plan failures.	Record committed tasks and integrate into daily/weekly work agenda, match commitments to capacity, and review committed tasks before the meeting.
Last planners remove constraints only during the IPD team meeting.	Requests during the weekly work plan meeting should not short-circuit the communication effort outside the meeting.

### 3.3.2 *Gap between Master Schedule and Weekly Work Plan*

Studying the planning process required developing an understanding of the relationship between performance at the weekly work plan level and performance at the overall project schedule level. To establish this relationship, I had to investigate and compare



slips or gains on the master schedule with each update to performance at the weekly work planning level expressed in percent plan complete (PPC).

The first section of the investigation required an in-depth study of the master schedule built in Primavera P6 scheduling software including: (1) monitoring project milestones with each update, (2) tracking changes to the schedule in terms of rescheduling, adding activities, adding detail into current activities, changing sequence/logic, altering durations, and adding new schedule fragments suggested during phase/pull sessions, and (3) analyzing the incremental slip or gain on schedule with each update. Since the scope of many milestones was changing during the early stages of design validation, it was necessary to choose an identifiable and consistent milestone to monitor. Accordingly, I chose the “end of design development” as a milestone to track with each schedule update.

To assess performance at the weekly work-plan level, I tracked PPC with each weekly update. PPC is a measure of reliability in execution of weekly work plans, calculated by dividing the number of weekly tasks planned by the number of weekly tasks accomplished. To adequately compare weekly PPC and incremental schedule changes on the master schedule, an aggregate PPC figure was calculated for 3 or 4 weeks, which is the average cycle for master schedule updates.

Figure 3.1 shows the relationship between percentage of work not complete or (1-PPC) in % and the incremental schedule difference in days. The argument is that the higher the percentage of work not complete, the higher should be the positive schedule difference or schedule slip. However, results show a weak correlation of 0.28 and a covariation of 1.01 between (1-PPC) % and incremental schedule difference. Therefore, a

clear relationship between weekly performance and overall schedule performance was not identifiable. In fact, these results suggest that PPC did not successfully represent overall schedule performance and weekly work plans were poorly linked to master schedules.

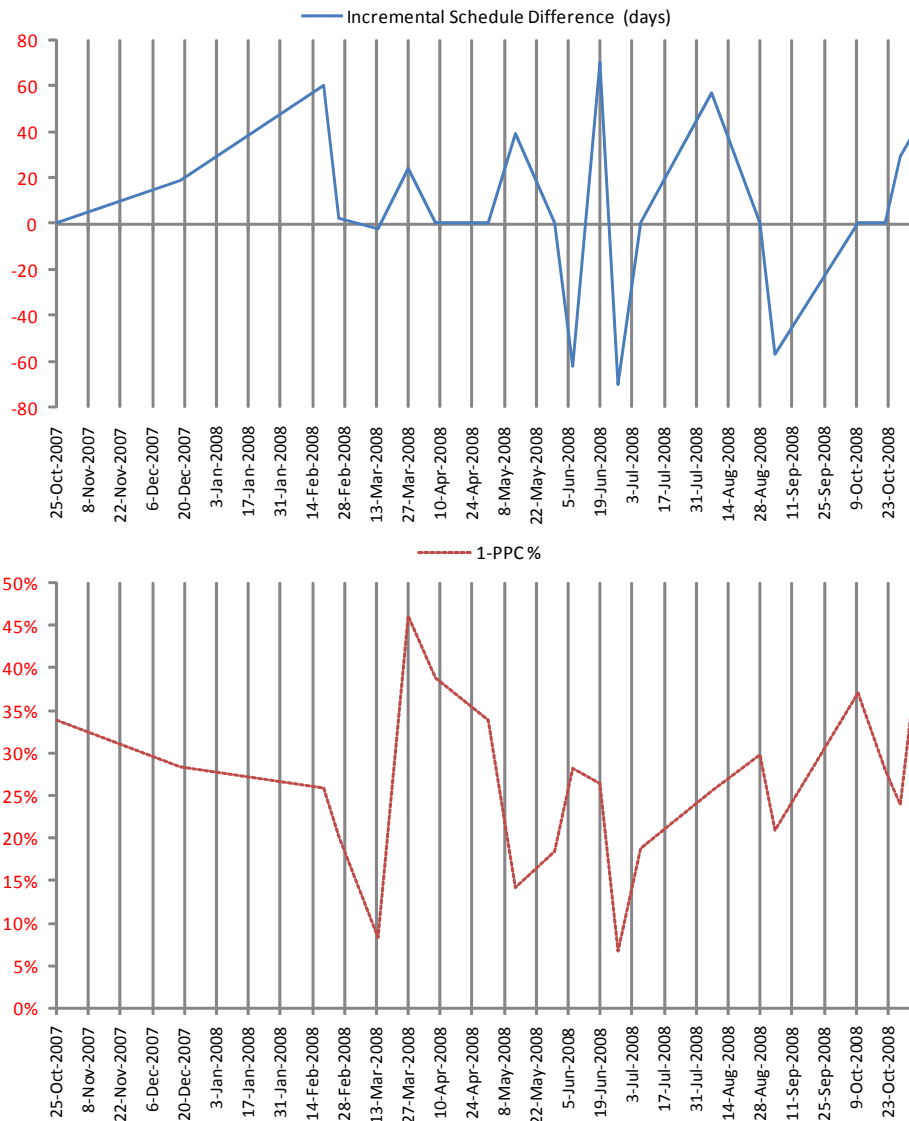

Figure 3.1: The relationship between percentage of work not complete (1-PPC) and incremental schedule difference

Analyzing the master schedule updates reveals high variations in schedule change where the schedule sometimes slips drastically from one update to another. To assess such

variations, the incremental schedule difference was normalized for a seven day period (i.e., calculating schedule slip for a period of time and pro-rating the slip for one week of elapsed time). Figure 3.2 plots these schedule differences against PPC. The premise here is that the maximum schedule-slip when PPC is 0% (i.e., no activities executed for the week) would be one week or 7 days; the minimum slip when PPC is 100% would be zero days; and any intermediate cases should fall close to the line shown in Figure 3.2 connecting those extremes. However, results show many deviations that suggest an inconsistent development of the master schedule in terms of updating logic and sequence. This is evident in Figure 3.2 where a certain milestone slips 13 days between one update and another update only one week later.

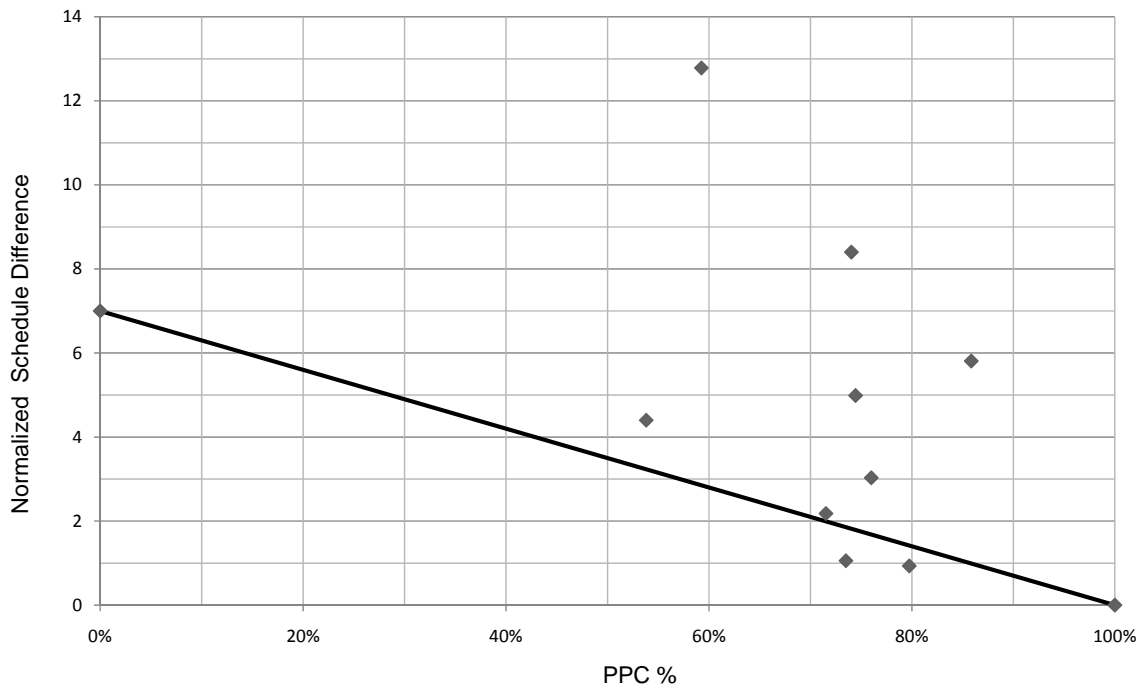

Figure 3.2: Scheduling stability performance comparing normalized schedule variance with PPC

Results of the study presented in this section show imperfections in the current planning process and a wide gap between long-term and short-term planning. This spawned many ideas for designing a new process taking the aforementioned process issues into account.

### **3.4 Designing the New Planning Process**

The CHH project's management and team leaders recognized the need to develop a new planning process model that: (1) integrates the planning processes at the cluster level with those at the intra-cluster level, (2) delineates the road map to a successful implementation of the LPS, and (3) synergizes input from all project stakeholders. The management at CHH project assigned this task to a transition team.

#### ***3.4.1 Team Formation***

The transition team, entrusted with developing a new process model, had several goals to achieve, including: assess the current implementation of the LPS, recommend adjustments, develop a new process, identify training needs, develop training programs, and study deployment models. The team involved cluster leaders and managers from the Architect/Engineer and the Construction Manager / General Contractor in addition to Professor Glenn Ballard and me from the University of California at Berkeley. The team met several times starting May 19<sup>th</sup> 2008. The following summarizes the results and recommendations that came out of team meetings.

#### ***3.4.2 Recommendations for Improving the Current Process***

The team investigated several development areas related to the current implementation of the LPS including: (1) cluster involvement, (2) mid-term planning (phase scheduling and lookahead planning), (3) information flow, (4) constraint analysis, (5) root cause analysis,

(6) first-run studies, (7) standardized planning tasks for cluster planning and IPD team sessions, (8) daily huddles, and (9) deployment of the new process. The team recommended improvements to the current process and later incorporated all improvements into a new planning process. Recommendations for improvement in each category follow:

Cluster involvement: The team recommended that clusters incorporate lookahead and weekly work planning into their respective weekly cluster meetings occurring at various times of the week. The master and phase schedule would be used as a yardstick for keeping important milestones in perspective. Moreover, each cluster would report their progress, present intra-cluster requests for removing constraints, and coordinate with other clusters during IPD team weekly meetings.

Phase scheduling: To avoid phase scheduling sessions involving too many people and becoming unproductive, it was suggested to run phase or pull sessions within each cluster. However, pull sessions could involve representatives from other clusters to better coordinate handoffs between specialists, identify gross constraints (those impacting a phase or a process), and find the best way to meet project milestones. The resulting schedules are to be incorporated in the master schedule and are later used in lookahead and weekly work planning.

Lookahead planning: Develop a lookahead planning process that properly links long-term to short-term schedules. As for cluster planning, it was recommended that each cluster performs lookahead planning by decomposing processes into operations, identifying constraints, and designing operations.

Constraint analysis: Gross constraints which impact phases and processes should be identified during pull sessions. Specific constraints impacting operations or steps can be identified and removed during lookahead and weekly work planning.

First run studies: The design of operations is to be developed during lookahead planning at least 3 weeks ahead of execution. A first run study is an actual first-time performance of an operation in order to study, learn, and improve the method to execute that operation. It involves developing deeper understanding of the work involved, the skills and resources needed, and the interactions with other operations. Potential processes requiring first run studies are those that are new, critical, or repetitive (Ballard et al. (1999a,1999b), Ballard and Hamzeh 2007). An example of a first run study performed at CHH project was the construction of object families in three dimensions (3D). The first run study proved that the process of identifying and building these families employing in-house and outsourced human resources is feasible and within budget.

Root cause analysis: An integral step of the “Built-in Quality Cycle: detect - correct - analyze - prevent - learn” is prevention (Ballard 2007). To prevent the recurrence of plan failures, root causes of planning breakdowns should be determined. The team suggested performing Root Cause Analysis (or 5 why’s analysis) at the cluster level and later present the results in IPD team meetings.

Standardized planning tasks for cluster and IPD team meetings: The team agreed to shift phase scheduling, lookahead planning, and weekly work planning to cluster meetings. IPD team meetings are to be reserved for cluster reports, discussing intra-cluster issues, learning the overall project progress, and removing constraints.

Daily huddles: These are short meetings held by a team at the start of a work day or shift. The team leader synchronizes the team's effort to daily goals established during weekly meetings. At the request of the transition team, the Building Information Modeling (BIM) group at CHH project participated in a test case to assess the value of daily team huddles during preconstruction, their impact on identifying constraints, and their role in streamlining work for the day. Results from this study did not present strong evidence to support implementation of daily huddles during design for the whole project. However, project practitioners advocate its use for production teams during construction.

Deployment of the new production planning model: The team discussed two main deployment methods for implementing the new process. The first method includes a stepwise deployment of the new planning process one cluster at a time. The other method involves full-fledged implementations across clusters. The team decided to go for a full fledge implementation for being faster to implement. Section 3.5.1 presents an in-depth discussion of the implementation process.

### ***3.4.3 The New Planning Process***

During early meetings, the transition team or what can be called “the planning process design team”, recognized the need to create an implementation process model for the LPS tailored to CHH project-specific needs, conditions, and challenges. Challenges recognized include: (1) the specific nature of design (high uncertainty in operations, iterative cycles, incubation time for design development, etc.), (2) the need for a standardized process to meet the needs of various disciplines and clusters, and (3) the limited prior experience with implementing lean and the LPS.

#### *3.4.3.1 Process Map*

After several preparatory meetings, the transition team used process mapping to create a layout of the process goals, steps, and responsibilities. After mapping the process, the team sought input from higher management and incorporated their feedback. Figure 3.3 is a process map showing the planning process designed for CHH project during preconstruction.

The process starts with developing the master schedule that serves as a basis for project delivery and milestone definition. It includes major project milestones including: entitlements, submittal of the first design increment to OSHPD, submittal of the second design increment, submittal of the third design increment, start of demolition, start of construction, and commissioning of hospital operations.

Figure 3.3 shows that the first step is identifying a milestone to map and highlighting the deliverables to release when the milestone is complete. However, it is crucial at this stage to align the perspectives of various project partners with respect to the milestone that is to be mapped. Accordingly, a ‘milestone alignment’ step involving all project stakeholders, is helpful in unifying the team’s expectations to what value needs to be delivered when executing this milestone.

‘Milestone alignment’ starts by identifying the interim customer as well as the end customer for each deliverable. This requires expressing in further detail the outcomes of each deliverable for each interim customer along the value chain. A deliverable, for example, might be “fire and life safety plans” for the final customer of this phase





OSHPD. Interim customers can be the architect, the mechanical consultant, the mechanical contractor, the fire life and safety consultant, etc. Defining the outcomes of each delivery goes hand-in-hand with expressing and communicating the conditions of satisfaction for an outcome to be delivered by a partner upstream to another project partner downstream. When a clear understanding of milestone deliverables is achieved, the team is ready to move to next stage of “phase / pull scheduling”.

“Phase / pull scheduling” is a collaborative process that a team can use to plan a milestone according to customer pull or value expectations. Since milestones were expressed in concrete deliverables during “milestone alignment”, phase scheduling sessions can now be conducted in smaller groups to increase the productivity of these sessions. Accordingly, phase scheduling sessions were conducted on a cluster-by-cluster basis although these sessions involved participants from other clusters who were invited to attend and provide input.

Cluster phase sessions start by breaking a milestone or deliverable to be mapped into constituent activities. This is followed by assigning durations and prerequisites to activities. Team members write this information on custom-made cards and post them on the wall. The next step, reverse phase scheduling, involves scheduling these constituent activities starting backwards from the milestone towards the start. Backward scheduling is helpful in uncovering constraints because it forces each team member to think of all prerequisites required to start their activity (Ballard 2000a).

As the reverse phase schedule starts taking shape, the start date is sometimes surpassed. When this happens, re-planning is required to fit the schedule into the available time frame. This exercise produces a cluster phase schedule with one of the

following characteristics: (1) an adjusted schedule with some float within the time frame allowed that can be redistributed to uncertain and crucial activities, (2) an adjusted schedule that fits the time frame snug tight, or (3) an adjusted schedule that does not meet the allotted time frame as shown in Figure 3.4. In the latter case, the milestone should be updated to reflect the actual circumstance. This can happen only after different alternatives required to fit the schedule into the assigned time do not meet the project value requirements (e.g., as cost, quality, and safety).

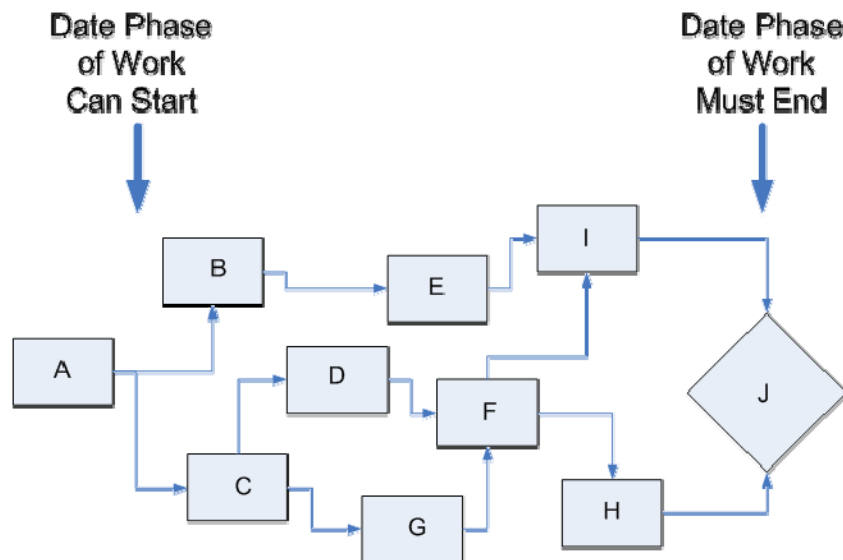

Figure 3.4: Reverse phase schedule exceeding limit limits (Ballard 2008)

After clusters finish producing their phase schedules, they meet in an IPD planning session to coordinate their schedules; especially activities that involve more than one cluster. Coordination starts prior to the meeting, by each party identifying activities, durations, constraints, and responsibilities. During the meeting, each party communicates his/her requests to remove constraints, expresses conditions of satisfaction, and obtains commitments to release these constraints. At the end of this exercise, the team produces a coordinated IPD phase schedule, ready to be executed. It is recommended that phase/ pull

scheduling starts prior to the beginning of a milestone so as to allow sufficient time to accommodate the team's input.

Putting the phase schedule into execution starts with "lookahead planning", when each cluster leader filters a six-week lookahead view from the phase schedule and forwards it to team members for evaluation and planning. Prior to a weekly cluster meeting, each project partner studies his/her activities, breaks the activities down into operations, sequences operations, assigns duration, allocates resource, and identifies constraints to complete tasks. The cluster then meets, plans next week's work, discusses constraints, identifies first run studies, and recognizes intra-cluster constraints. The resultant lookahead plan is later used as a guide for weekly work planning.

"Weekly work planning" builds on the six-week lookahead plan previously developed. Each cluster uses weekly meetings to report progress on last week's plan, to update the lookahead plan, and to produce next week's work plan. Reporting progress involves evaluating PPC for each cluster and for the team as whole. Non-completed tasks undergo root cause analysis to uncover the root cause of non-performance and develop preventive actions to inhibit the same failure from recurring.

In preparing next week's work plan it is crucial to discuss constrained tasks, make requests to other last planners to remove constraints, and make activities ready by removing constraints. The team identifies intra-cluster constraints and formulates requests for removal. These requests can be made later during IPD team meetings. At this stage, last planners are in a good position to commit to next week's work plan and place some non-critical activities on the fall-back / follow-on list to be performed should extra capacity be available.

### 3.4.3.2 Planning/Scheduling Development Plan

While Figure 3.3 was helpful in mapping the planning process, a visual presentation of the process was required to explain the process to the last planners. The transition team assigned Andy Sparapani and me to develop a handbook for the last planner implementation at CHH project. Addressing the intermediate planning process, the following section explains in detail the breakdown of activities from the master schedule to the weekly work plan.

Figure 3.5 shows a general layout of the four planning processes that combine to form the LPS. Figure 3.6 presents the LPS in further detail. The first step in the process is developing the master schedule that incorporates the owner's expectations, logistics plans, and work strategies. The master schedule presents milestones and activities representing phases.

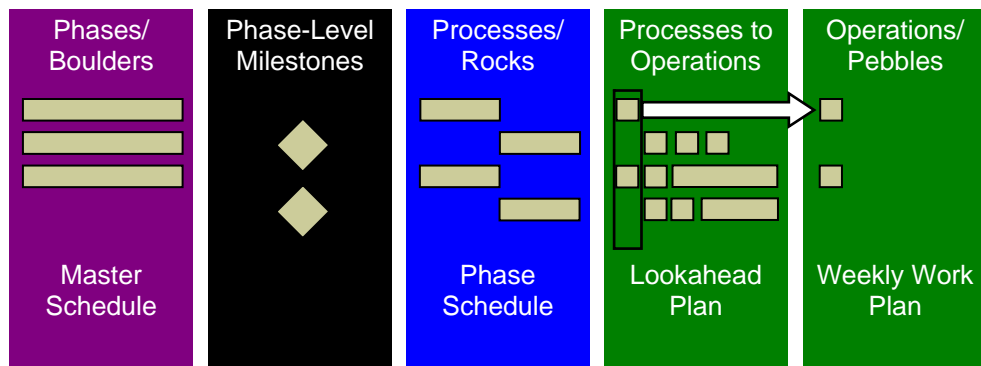

Figure 3.5: Overview of planning processes in the LPS at CHH project (The Last Planner Handbook at CHH project, 2009)

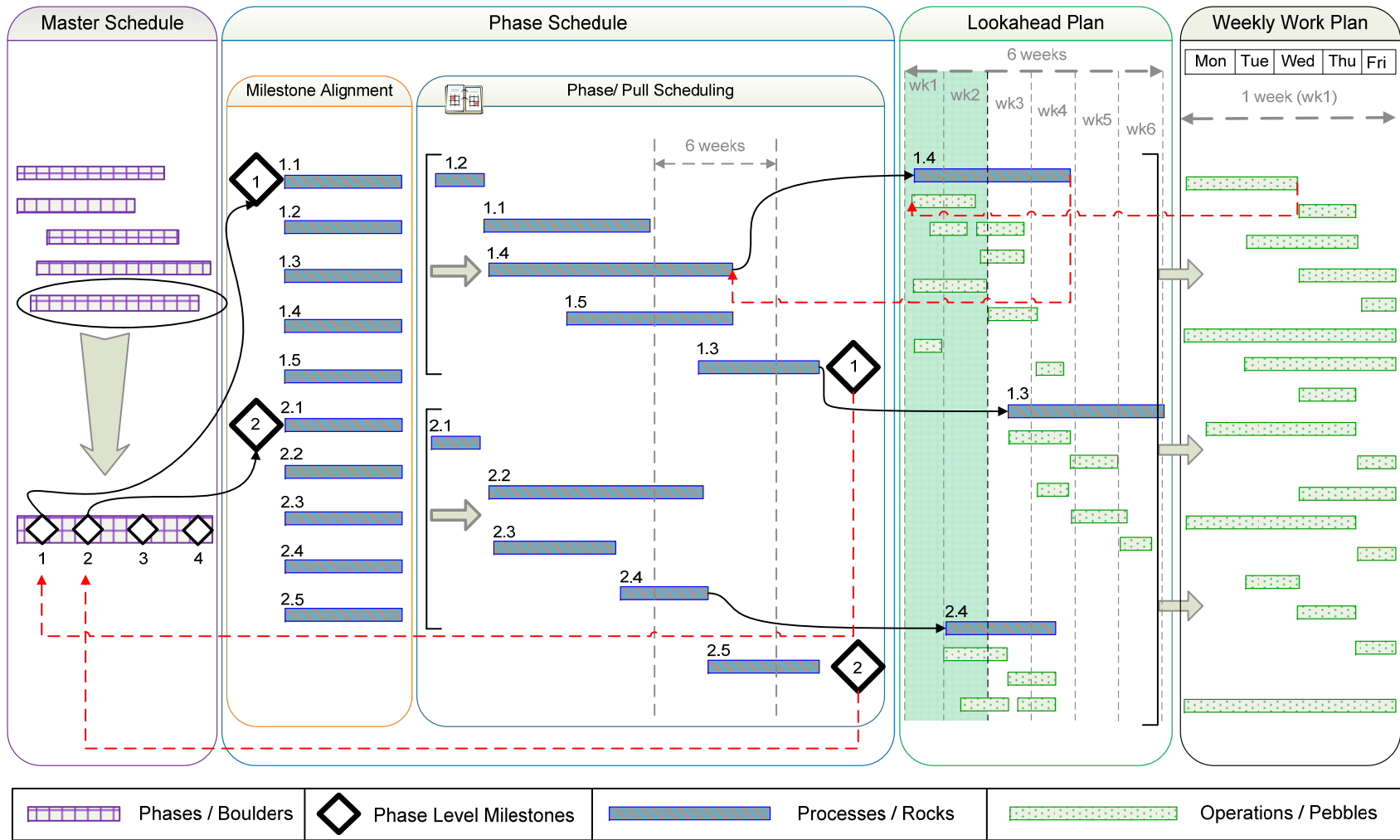

Figure 3.6: The LPS scheduling development model at CHH project

“Milestone alignment”, discussed in section 3.4.3.1, aligns stakeholder expectations for the milestone in question. This is a preparatory step for the subsequent planning processes in “phase / scheduling” that involves: (1) breaking down the milestone, phase, or boulder (a coarse description of an activity) into constituent processes represented by rocks (a finer description of an activity), (2) reverse phase scheduling, and (3) readjusting the schedule to meet the allotted time frame.

At CHH project, the project master scheduler, in-charge of developing and maintaining the master schedule, used Primavera P6 to build the master schedule and the phase schedule. After updating the schedule, he extracts a six-week filter and forwards it to individual clusters to perform lookahead planning and to build weekly work plans as shown in Figure 3.7. Lookahead planning involves (1) breaking down processes / rocks into operations represented by pebbles, (2) sequencing operations and delineating resource allocation, (3) identifying and removing constraints, and (4) designing operations including the need for first run studies.

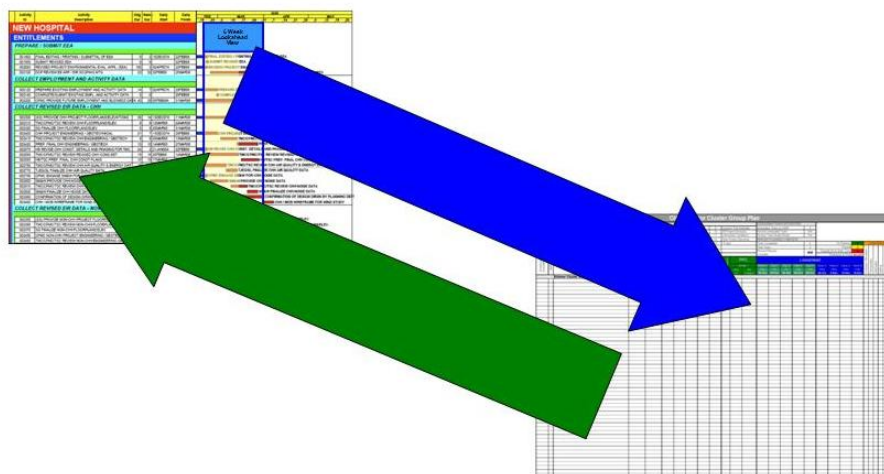

Figure 3.7: Filtering and feedback between the master schedule and cluster lookahead plan (The Last Planner Handbook at CHH project, 2009)

Figure 3.6 shows the lookahead planning process that produces a detailed two-week lookahead backlog of constraint-free or constrained tasks that can be made ready. The team chooses tasks from the lookahead backlog to develop the weekly work plan by moving critical tasks and made-ready tasks into next week's weekly work plan. Lower-priority tasks are listed on the workable backlog to be performed in case of extra capacity.

Weekly work planning involves various planning functions including: (1) advancing tasks that are well defined, constraint-free, properly sequenced, and that have resources available, (2) performing collaborative weekly work planning, (3) exercising reliable promising, and (4) learning from plan failures.

#### *3.4.3.3 Information flow*

The new planning process dictates new pathways for information flow. Figure 3.8 presents the information exchange for the planning process between last planners, cluster leaders, the planning facilitator, and the master scheduler. Figure 3.9 shows a global view of this information-flow model depicting phase / pull scheduling sessions, cluster group meetings, and IPD team planning meetings.

Two or three months before the beginning of a phase, individual cluster groups meet and develop a phase schedule. The master scheduler incorporates this information into the master schedule built in Primavera P6. This master schedule is later updated biweekly in a meeting involving various cluster groups. A six-week lookahead view is filtered from the master schedule and sent through the planning facilitator, in charge of coordinating planning processes between cluster teams, to cluster leaders who in turn



filter tasks by discipline and forwards it to the designated project partners (The Last Planner Handbook at CHH project, 2009).

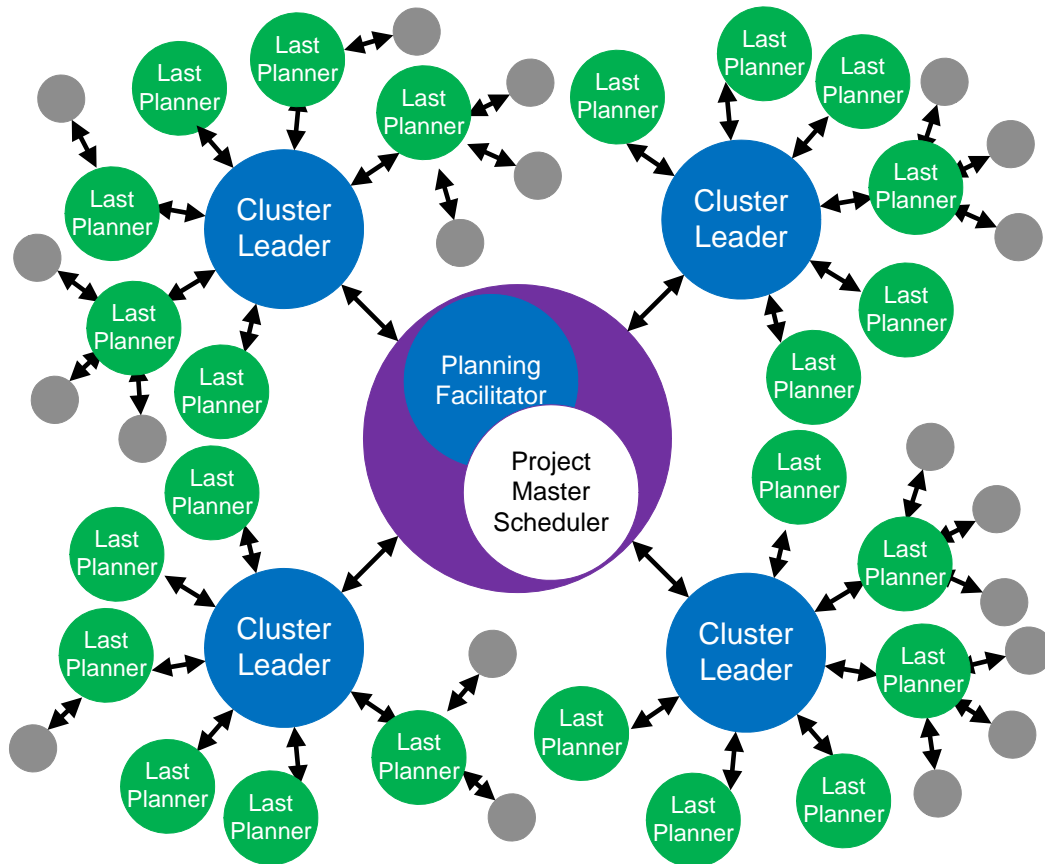

Figure 3.8: Information flow between team planners at CHH project (The Last Planner Handbook at CHH project, 2009)

In their respective weekly meetings, individual cluster groups perform lookahead planning, develop weekly work plans, and identify constraints. Each cluster leader then reports cluster progress and intra-cluster requests to remove constraints during IPD weekly team meetings. Constraint removal and planning issues raised during these meetings are then incorporated into the master schedule to start a new cycle. The planning facilitator is monitoring the overall process, assisting in pull sessions, and overlooking team meetings to insure a smooth flow of information and team planning.

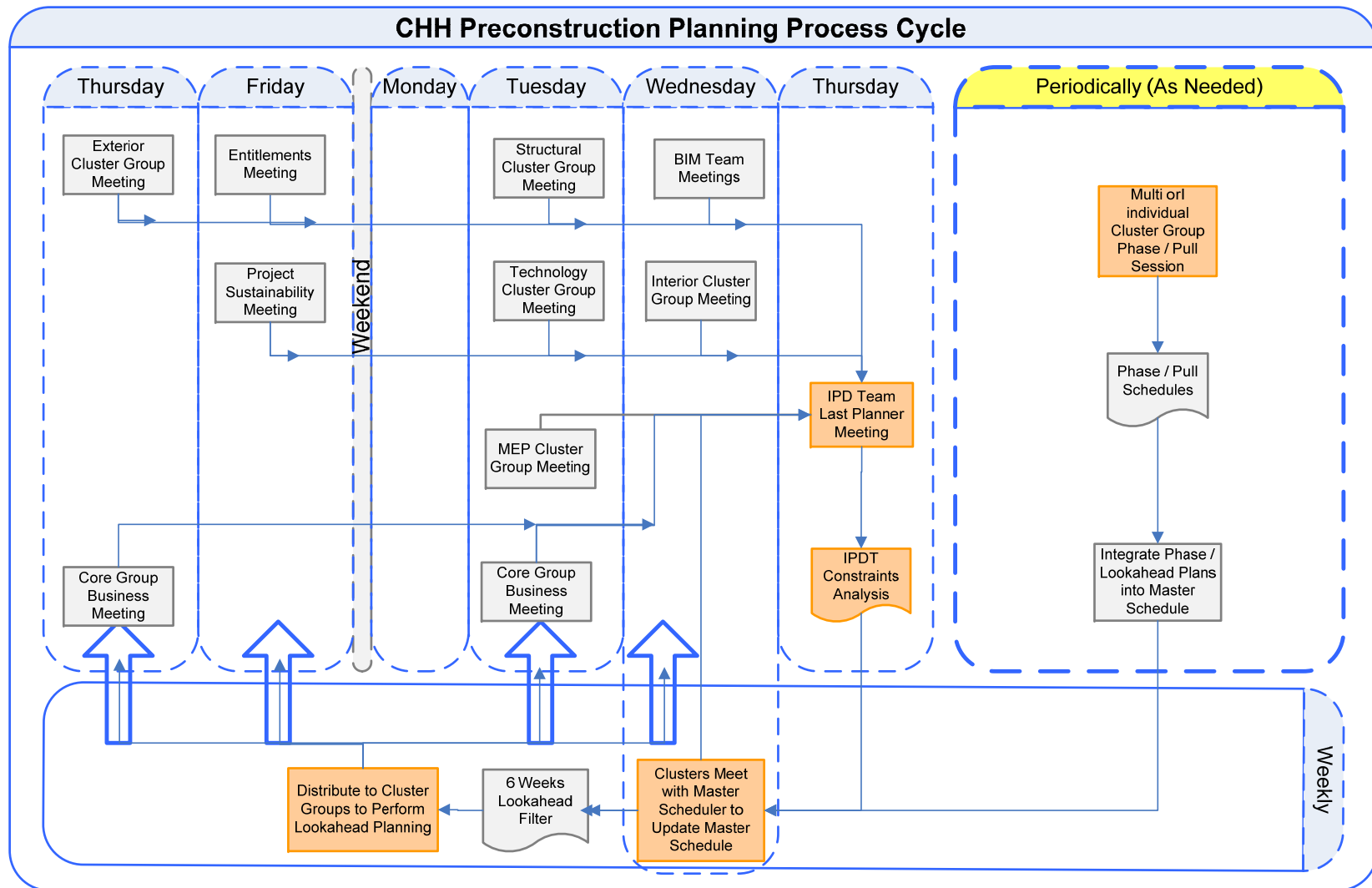

Figure 3.9: Information flow model for planning processes at CHH project (Modified from The Last Planner Handbook at CHH project, 2009)

## **3.5 Implementing the New Planning Process**

### ***3.5.1 Training***

The transition team recognized the need to conduct training sessions for CHH project preconstruction staff in lean methods in general and the LPS in particular. In collaboration with Professor Glenn Ballard, the transition team composed a training program to teach various aspects of lean theory, methods, and tools. This program included four main sections: (1) introduction to lean history, concepts, and methods, (2) basic training modules, (3) lean project delivery, and (4) lean management.

Coaches from the IPD team were assigned to produce and teach the basic training. These modules include: (1) value stream mapping, (2) 5 S (sort, set in-order, shine, standardize, sustain), (3) reliable promising, (4) learning from experiments, (5) learning from breakdowns, (6) Choosing by Advantages, and (7) A3 reports.

The team developed Section 3 of the training, lean project delivery, in collaboration with Professor Ballard incorporating examples and applications from the preconstruction phase at CHH project. This section includes a wide range of topics including: (1) the LPS, (2) target value design, (3) design management, (4) supply chain management, and (5) design of construction operations. These training sessions were planned to take place during a later stage of the project.

Section 4 of the training, lean management, targets all team supervisors and will involve superintendents at a later stage. This training introduces essential tools for team leaders including: leader's standard work, daily accountability processes, visual controls,

developing people, leading change, problem solving / process involvement, and lean management system assessment.

### ***3.5.2 Start-up***

Following the introductory course to lean and the LPS, the new process was introduced simultaneously across various clusters. It was necessary to deploy the new process immediately to involve all team members in planning their work and building their cluster mid-term and short-term schedules. The project's planning facilitator launched the new process during an IPD meeting to the whole team using a training module. This module was later incorporated in the first version of the last planner handbook that was made available to different cluster groups.

The planning facilitator followed the launch by one-to-one training sessions with cluster leaders showing them the planning steps required and the leading/collaborative role to be played by cluster leaders. Once the process was put in action, team members identified glitches and communicated them to the rest of the team during IPD team meetings. Such glitches include: improper incorporation of requests for constraint removal during IPD team meetings, various presentations of cluster work plans, insufficient definition of work tasks, and incomplete presentation of performance metrics. Feedback from the team was used to adjust the process, which is considered in a state of continuous improvement.

## **3.6 Implementation Challenges**

Although the Last Planner<sup>TM</sup> System may seem intuitive and realistic for creating collaborative schedules, refining tasks as they get closer to completion, using quality

assignments, removing constraints to make activities ready, and emphasizing reliable promising, practical applications of the system may face many challenges. These challenges include local factors attributed specifically to the project and general factors impacting the implementation of any novel methods.

#### *3.6.1.1 Local Factors*

Local factors are potential challenges attributed to project circumstances and the team including: fairly new experience in lean methods, traditional project management methods, novelty of the LPS to designers, fragmented leadership, and team chemistry.

While the experience factor can be mitigated by periodic training sessions for old and new team members, the other factors require a longer-horizon plan. The presence of an IFOA has a critical impact on developing a collaborative team that shares pains and gains on a project. Diluting the impact of traditional management methods can be achieved by a continuous appraisal of the current process in relation to lean goals and Sutter's 'five big ideas'.

#### *3.6.1.2 General Factors*

General factors impacting the implementation of a new process include: human capital, organizational inertia, resistance to change, technological barriers, and climate. Although analyzing these factors in detail and studying their impact on the project are not the goals of this study, it is necessary to layout factors that may impede the application of a novel planning process on a construction project.

Human capital is associated with human skills and experience required on a project. It addresses the need to continuously develop new skills as new technologies, processes, and policies are implemented.

Inertia increases the resistance to change in organizations. Inertia is attributed to both internal structural arrangement and external environment. Internal factors include: (1) investments that are sunk in plant, equipment, and personnel, (2) incomplete information reaching decision makers, (3) internal political constraints such as fear that change may disrupt internal political equilibrium, and (4) constraints generated by an organization's history such as standard procedures and normative agreements. External factors are equally significant and include: (1) barriers to entry and exit from markets (e.g., legal setting), (2) incomplete information about external environment (demands, threats, and opportunities), (3) legitimacy constraints arising when a new norm challenges/changes established legitimized norms, and (4) collective rationality problems (e.g., a strategy found rational for a certain decision maker may not necessarily be rational for a large number of decision makers) (Hannan and Freeman 1977).

Resistance to change, which is closely related to inertia, is high in an organization when individuals believe that inertia is high and that they will do tomorrow the same thing they are doing today (Zammuto and Krackower 1991).

Technological barriers may have a substantial impact on the success of a novel processes. The apparent influences include: lack of experience with new technologies, the instability and breakdowns in using these technologies, incompatibility with current systems, and investment in the form of time, cost, quality of processes, and human capital.

Climate is an organizational characteristic that employees live through and experience while working for an organization. The climate shapes their behavior, performance, and the way they perceive the organization. Climate thus influences an organization's ability to change and the change process. Two overlapping types of climate considered in the literature are psychological and organizational. Several dimensions contribute to the perception of psychological climate in an organization such as: autonomy, cohesion, trust, pressure, support, recognition, fairness, and innovation (Koys and Decotiis 1991).

### **3.7 Summary and Conclusions**

Many factors distinguish production planning and control during design from that during construction. Ballard et al. (2009) highlight three of these factors: (1) greater uncertainty of ends and means that reduces the ability to foresee the sequence of future tasks, (2) the negative impacts of increasing the speed of design tasks on removing constraints and making tasks ready for execution, and (3) interdependencies between design tasks that increase work complexity and obscure planning functions.

Despite challenges emanating from the novelty of the LPS to designers at CHH project, the IPD team took great strides in transitioning to the new planning process. This was evident in the "Cathedral Hill Pulse Report" which involved results and feedback from team members on a survey investigating the team's performance in various management areas (CHPR 2008). We can conclude from the collected evidence that: (1) architects and designers became more comfortable planning their weekly work and utilizing pull sessions, (2) LPS helped boost communication within a cluster and among clusters, (3) learning from failures did not take full shape within LPS although but was counterbalanced with the use of the A3 problem-solving process that involved analysis of

past actions and suggestions for improvement (Shook 2008), (4) training on LPS contributed to rapid deployment of the planning process, and (5) the role of the owner and the core group was a key component in supporting process implementation.

While not a goal of this study, establishing metrics and measurement methods for evaluating the above mentioned factors would be helpful to compare production planning and control during design with that during construction. This may be the seed for future research projects in this area.

One of the planning challenges identified by this study is the planning process required for ‘creative design’ tasks. These tasks are defined in this study as tasks requiring a high degree of innovation, originality, creativity, inspiration, design incubation time, and design talent. ‘Creative design’ tasks are very difficult to plan and monitor due to uncertainty in duration and scope of the work involved. They depend more on the inspiration of the designer than on the time spent performing the design. Since a ‘creative design’ task may sometimes span over several weeks, the team had difficulty breaking it down to fit into the weekly work plan. Further research is required to develop a planning process to tackle such design tasks.

One of the success factors in driving the implementation of LPS and in leading continuous improvement efforts is strong leadership. The implementation process at CHH project suffered several breakdowns several of which can be attributed to fragmented leadership. While the LPS implementation handbook developed at CHH project sets a clear method to measure performance metrics (PPC, TA, and TMR), no global leadership decision was taken to implement such measurements across all clusters on the project. At the time of writing this report only one cluster was reporting PPC and



TA after five months of introducing the process and training the last planners. The fact that this specific cluster has shown higher levels of PPC (83% over 5 months after implanting the new process) compared to PPC of the IPD team (74% over 12 months before implementing the new process) does not provide enough support to indicate significant improvements in planning performance.

As a consequence to the lack of data collected on performance metrics (PPC, TA, and TMR), it was infeasible to perform a study comparing the team's performance in terms of phase scheduling, lookahead planning, and weekly work planning before and after implementing the LPS on the project. However, compared to the informal fashion in which construction companies practice production planning and control (Kemmer et al. (2007), the implementation of LPS on this project remains a model for industry practice when it comes to standardized production planning and promoting collaborative planning processes.

### **3.8 References**

- Ballard, G., (1997). "Lookahead Planning: The Missing Link in Production Control", *Proceedings of the 5th Annual Conference of the International Group for Lean Construction, IGLC 5*, July, Gold Coast, Australia, pp. 13-26.
- Ballard, G., and Howell, G. (1998). "Shielding Production: An Essential Step in Production Control," *Journal of Construction Engineering and Management*, ASCE, 124 (1), pp. 11-17.
- Ballard, G. (2000a). *The Last Planner System of Production Control*. Ph.D. Diss., Faculty of Engineering, School of Civil Engineering, the University of Birmingham, UK, 192 pp.
- Ballard, G., (2007). "Built-in Quality Workshop", *Training Workshop – Project Production Systems Laboratory (P<sup>2</sup>SL)*, University of California, Berkeley, (October 8th).

- Ballard, G., and Hamzeh, F.R. (2007). “The Last Planner Production Workbook- Improving Reliability in Planning and Workflow”, 2<sup>nd</sup> Edition, Lean Construction Institute, California, USA, 81 pp.
- Ballard, G., Hammond, J., and Nickerson, R. (2009). “Production Control Principles”, *Proc. 17<sup>th</sup> Annual Conf. Intl. Group for Lean Construction*, Taipei, Taiwan.
- CHPR (2008). “Cathedral Hill Pulse Report”, Integrated Project Delivery Team, Cathedral Hill Hospital Project, December, San Francisco, CA, 10 pp.
- Flores, F. (1982). Management and Communication in the Office of the Future, PhD Dissertation, University of California at Berkeley.
- Hannan, M.T., and Freeman, J. (1977). “The Population Ecology of Organizations.” *The American Journal of Sociology*, 82(5), March, pp. 929-964.
- IFOA (2008). “Integrated Form of Agreement”, Integrated Project Delivery Team, Cathedral Hill Hospital Project, San Francisco, CA.
- Kemmer, S.L., Heineck, L.F.M., Novaes, M.V., Mourao, A.M.A., and Alves, T. da C.L. (2007). “Medium-Term Planning: Contributions Based on Field Application”, *Proc. 15<sup>th</sup> Ann. Conf. Int’l. Group for Lean Constr., IGLC 15*, 18-20 July, East Lansing, Michigan, pp. 509-518.
- Koys, D.J. and Decotiis, T.A. (1991). “Inductive Measures of Psychological Climate.” *Human Relations*, 44(3), pp. 265-285.
- Lichtig, W.A. (2005). “Sutter Health: Developing a Contracting Model to Support Lean Project Delivery”, *Lean Construction Journal*, 2(1), pp. 105-112.
- Lichtig, W.A. (2006). “The Integrated Agreement for Lean Project Delivery.” *Construction Lawyer*, 26(3), 8 pp.
- Macomber, H., and Howell, G. (2003). “Foundations of Lean Construction: Linguistic Action”. *Proceedings of the 11<sup>th</sup> annual conference of the International Group for Lean Construction*, Blacksburg, VA.
- Macomber H. (2004). “Securing Reliable Promises on Projects: A Guide to Developing A New Practice”, [http://halmacomber.com/MSRP/reliable\\_promises.pdf](http://halmacomber.com/MSRP/reliable_promises.pdf), last accessed April 2009.
- OSHPD (2008). “Phased Plan Review.” Office of Statewide Health Planning and Development, Facilities Development Division, White Paper, 13 pp.

- Rother, M., and Shook, J. (1998) *Learning to See: Value Stream Mapping to Add Value and Eliminate MUDA*. Lean Enterprise Institute, Brookline, MA, 96 pp.
- Shook, J. (2008). *Managing to Learn: Using the A3 Management Process to Solve Problems, Gain Agreement, Mentor, and Lead*. Lean Enterprise Institute, 138 pp.
- The Last Planner Handbook at CHH project (2009). IPD team at CHH project, Version 2.0, San Francisco, CA, 14 pp.
- Validation Study Report (2007). Integrated Project Delivery Team, Cathedral Hill Hospital Project, 16 July, San Francisco, CA, 790 pp.
- Zammuto, R.F. and Krakower, J.Y. (1991). "Quantitative and Qualitative Studies in Organizational Culture." *Research in Organizational Change and Development*, Vol. 5, pp. 83-11.

**CHAPTER 4 - SUPPORTING CASE STUDIES-**  
**FAIRFIELD MEDICAL OFFICE BUILDING, THE**  
**RETREAT AT FORT BAKER, AND UCSF'S**  
**CARDIOVASCULAR RESEARCH CENTER**

This chapter presents results from case study research conducted on three projects in San Francisco, California, all of which implemented the Last Planner™ System (LPS) for production planning and control. It describes the planning processes implemented on these projects and their performance. The focus is on planning processes connecting long-term planning (master scheduling) to short-term planning (weekly work planning).

Results from this chapter confirm the need for more effective lookahead planning processes to better connect weekly work plans to the master schedule on construction projects. It validates the industry's need to adopt standardized planning practices, similar to the guidelines presented in Chapter 5.

Chapter 4 is divided into three sections, each presenting research results from one project. Each section begins with an overall description of the project, followed by a description and critique of the planning processes found on the project, and ends with a summary of lessons learned and suggestions for further improvement.

## **4.1 Fairfield Medical Office Building**

### ***4.1.1 Background***

The project is a three-story medical office building built for Sutter Regional Medical Foundation in Fairfield, California. The building was designed by HGA Architects and Engineers and built by a construction team lead by The Boldt Company as Construction Manager. In addition to administrative offices, the building houses offices for various medical specialists including: family practice, expanded laboratory, pediatrics, internal medicine, oncology, rheumatology, and cardiology (The Boldt Company 2006).

Using Building Information Modeling (BIM), Target Costing, and Lean Project Delivery (including the LPS for production planning and control), the project team designed and constructed the project for an actual cost of around \$19.4 Million (compared to a target cost of around \$19.6) in 25 months between 2006 and 2008 (The Boldt Company 2006).

### ***4.1.2 Long-Term and Short-Term Planning Processes***

The Construction Manager built and maintained the project's master schedule in Microsoft Project and monitored weekly production planning using the LPS for production planning and control. The master schedule was periodically updated and adjusted incorporating feedback from last planners on site. Percent plan complete (PPC) was recorded and tracked as a measure of reliable weekly work planning. To investigate the relationship between long-term planning and short-term planning I looked closer into the master schedule and weekly work plans.

The master schedule was built incorporating results from several collaborative pull / phase scheduling sessions involving project parties. The master schedule included seven major milestone stages: (1) site work and utilities, (2) substructure, (3) superstructure, (4) interior system rough-in, (5) enclosure, (6) interior system finishes, and (7) project close-out. To measure project performance relative to this base master schedule, I monitored schedule slippage or gain with every master schedule update for each of the above mentioned milestones. Measuring the schedule difference between each update and the base master schedule, Figure 4.1 presents incremental schedule for seven major milestones calculated with each master schedule update.

Comparing the schedule difference graphs for seven project milestones presented in Figure 4.1 shows a gradual decrease in the amplitude of schedule difference as the project gets closer to completion. This shows that although the project sustained schedule delays at the outset of the project, the project team was able to reduce the impact of those early delays on subsequent project phases.

In fact, the management held the project completing milestone constant by performing continuous re-planning (using collaborative phase / pull scheduling) with each update of the master schedule. The project team built alternative schedules to absorb delays and meet the specified project end date. Developing these alternative schedules required scheduling more tasks to run in parallel, thus reducing the impacts of early project delays and allowing later tasks to start at their original start date (Sparapani 2008).

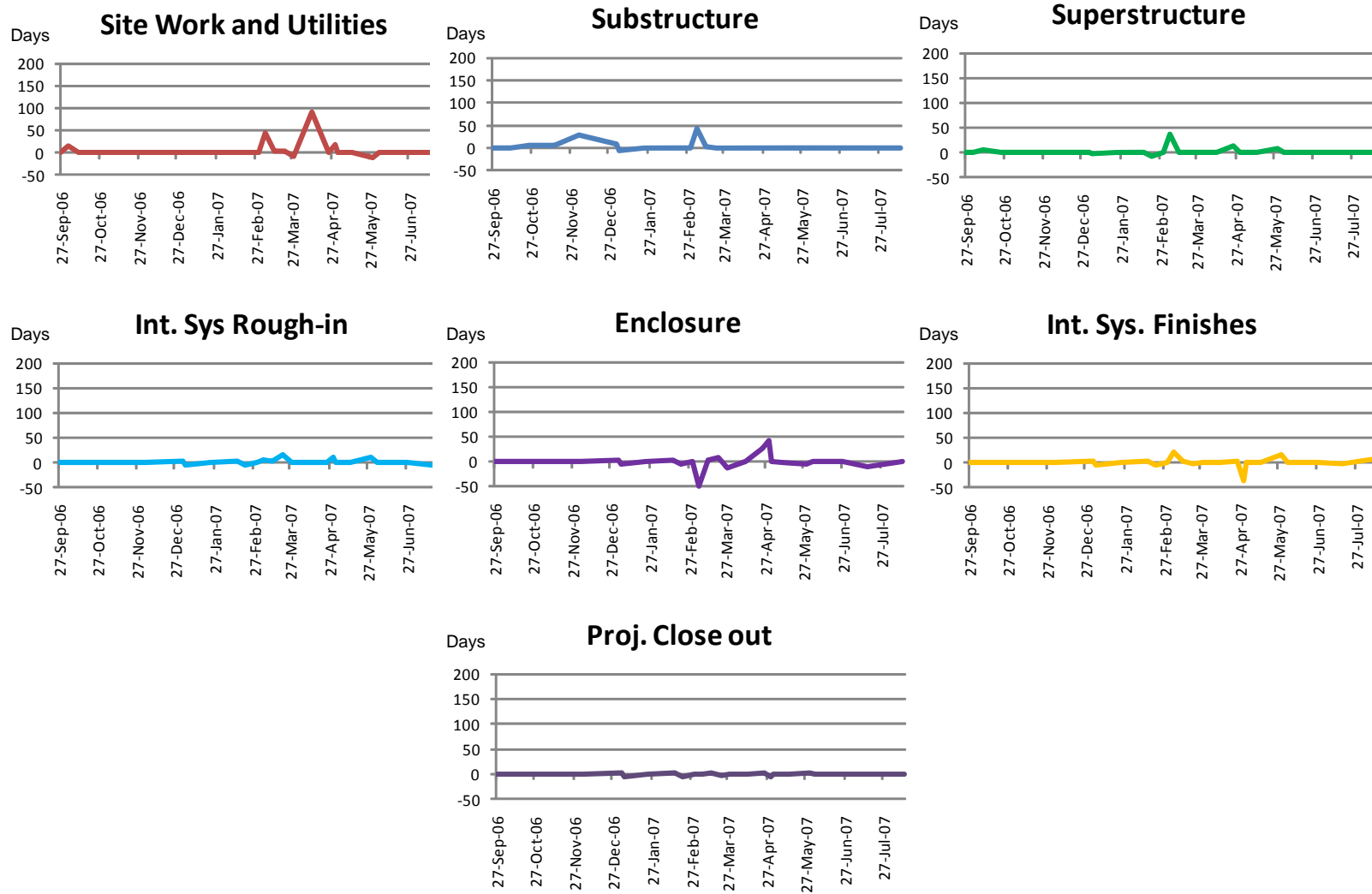

Figure 4.1: Incremental schedule difference for seven milestone stages at Fairfield Medical Office Building

Figure 4.2 shows the standard deviation of the schedule difference relative to the base master schedule for each of the seven project milestones mentioned before. It confirms the efforts that the project team exercised to dampen the impacts of earlier project delays and bring the project to a successful completion. It also shows a larger schedule difference for site works and utilities. These earlier project works are sometimes not given enough management attention but impact all subsequent work on the project.

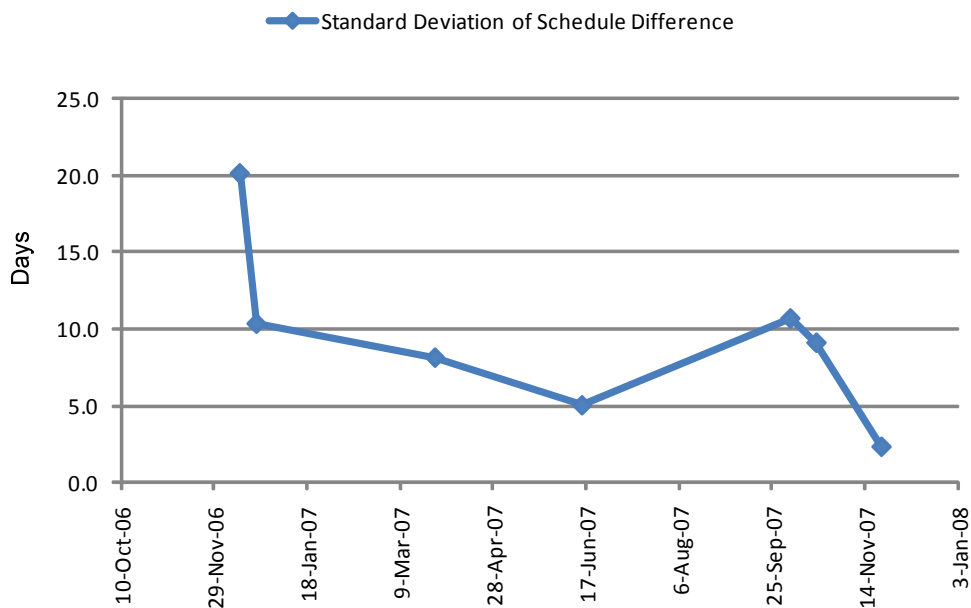

Figure 4.2: Standard deviation of schedule difference for each milestone from original planned date

Short-term planning on the project involved developing weekly work plans in Excel spreadsheets and monitoring performance with the team. These weekly work plans were based on the master schedule that was built in Microsoft Project and updated every week. PPC, used to measure the reliability of weekly work plans, was monitored on a weekly basis. Figure 4.3 shows the PPC for eight months of the project.



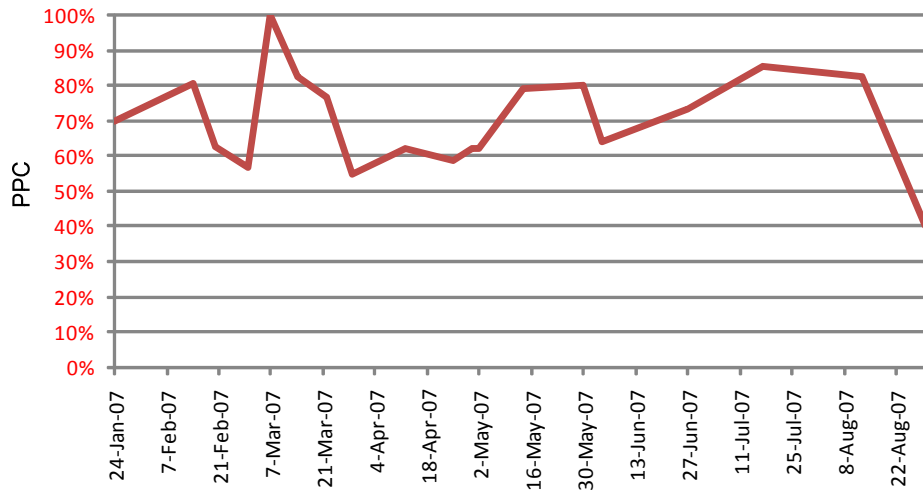

Figure 4.3: Percent Plan Complete (PPC) figures for a portion of the project.

Because the project end date was not allowed to slip with each schedule update, it is difficult to measure the impact of PPC on overall schedule performance. While Figure 4.1 shows schedule slippage / gain for the seven project milestones monitored with each update, the project performance cannot be attributed to the performance of any of these milestones separately. Accordingly, comparison and correlation measurement between overall project performance and weekly work planning performance is not feasible.

#### **4.1.3 Conclusions**

Although this case study does not present major insights into the relationship between long-term and short-term planning, it presents insights into planning practices performed on construction projects. One method that construction professionals use in developing recovery schedules is running many tasks in parallel. While this method of acceleration may help gain some ground on schedule, it could expose the project to the risks of congestion, decreased productivity, and compromised quality. However, I was not able to

study the secondary impacts of performing parallel tasks on project cost and quality because productivity data was not available on this project.

The project end date was the only milestone held constant while other project milestones were allowed to vary based. Many questions come to mind in this case: Did the Fairfield Medical Office Building schedule comprise various highly variable interrelated work phases? Did the project team introduce variability by “lowering the river to reveal the rocks”? Were the project phases in the master schedule tightly coupled? Did the master schedule incorporate large float between activities? Were schedule buffers intentionally constructed and artfully located? Did the regular swings in PPC have an impact on milestone slippage?

The available data from this case study do not support the formation of answers to these questions. However, it is apparent that the Integrated Project Delivery approach was helpful in generating team collaboration and continuous planning. One lesson learned from this project, is the importance of taking quick actions to deal with plan failures and to avoid harmful ripple effects from early project delays on the rest of the project. Another lesson learned, is the importance of team re-planning to meet project milestones, reducing schedule overruns, and developing recovery schedules using collaborative phase / pull scheduling when project milestones are slipping.

## **4.2 The Retreat at Fort Baker**

### ***4.2.1 Background***

The project involved rehabilitation of 23 buildings, new construction of 14 buildings, and landscape works for Fort Baker Retreat Group LLC at Fort Baker, Sausalito, California.

The architect for the \$103 Million project was Architectural Resources Group (historic buildings) and Leddy Maytum Stacy (new construction) and the General Contractor was Herrero Contractors Inc. \$45 Million of the project's cost went to the rehabilitation of 23 historic buildings (Quakenbush 2008).

This study focuses on the project planning practices performed on the rehabilitation section of the project. The General Contractor (GC), who played the role of connecting all trade contractors and subcontractors on the project, used the LPS on the project to manage production.

The GC developed the master schedule for the project using pull / phase scheduling sessions in collaboration with trade contractors and subcontractors. The only milestone the team focused on was project handover in June 2008; everything in between project start and project handover was decided using pull sessions (including the opening of 75 rooms by May 2008). The GC continuously incorporated results from these sessions into the master schedule that was built in Microsoft Project and updated on a weekly basis.

#### ***4.2.2 Long-Term and Short-Term Planning Processes***

Long-term planning on this project involved the development of the project's master schedule through various pull sessions that were performed as the project progressed. The master schedule was built and updated in Microsoft Project. For the rehabilitation part of the project comprising 23 buildings, the master schedule was developed to allow for a flow of construction trades from one building to another.

Last planners representing the trade contractors and subcontractors on the project, used pull sessions to map the flow of trades and construction sequence of buildings. The

resulting master schedule showed earlier start dates for buildings having a larger scope of rehabilitation work (i.e., larger scope buildings such as building 601 and building 602 were given priority over smaller scope buildings such as building 623). The project handover in June 2008, was the end milestone that the team used to pull to during phase / pull scheduling sessions although the opening of 75 rooms by May 2008, was an important milestone that the team had to incorporate (Hofmann 2008).

The project team used the LPS for weekly work planning based on the master schedule. The team conducted weekly meetings for last planners who developed the next week's plan in Microsoft Excel, coordinated their work, updated the previous week's work plan, and used PPC to monitor the performance of production planning.

To compare the performance of long-term planning and short-term planning processes, I monitored the schedule difference for each master schedule update measured against the earlier update and compared it with the percentage of tasks not performed on the weekly work plan represented by (1-PPC). The assumption is that the higher the percentage of work not-complete on the weekly work plan (i.e., higher '1-PPC') the higher the schedule slip on the master schedule (i.e., positive schedule difference).

Figures 4.4 and 4.5 show the incremental schedule difference measured with each update plotted against the corresponding (1-PPC) covering the period from January 2007 to April 2008 for buildings 601 and 602 respectively. For example, if schedule difference is calculated over a two-week period, '1-PPC' is calculated by averaging the result for these two weeks.

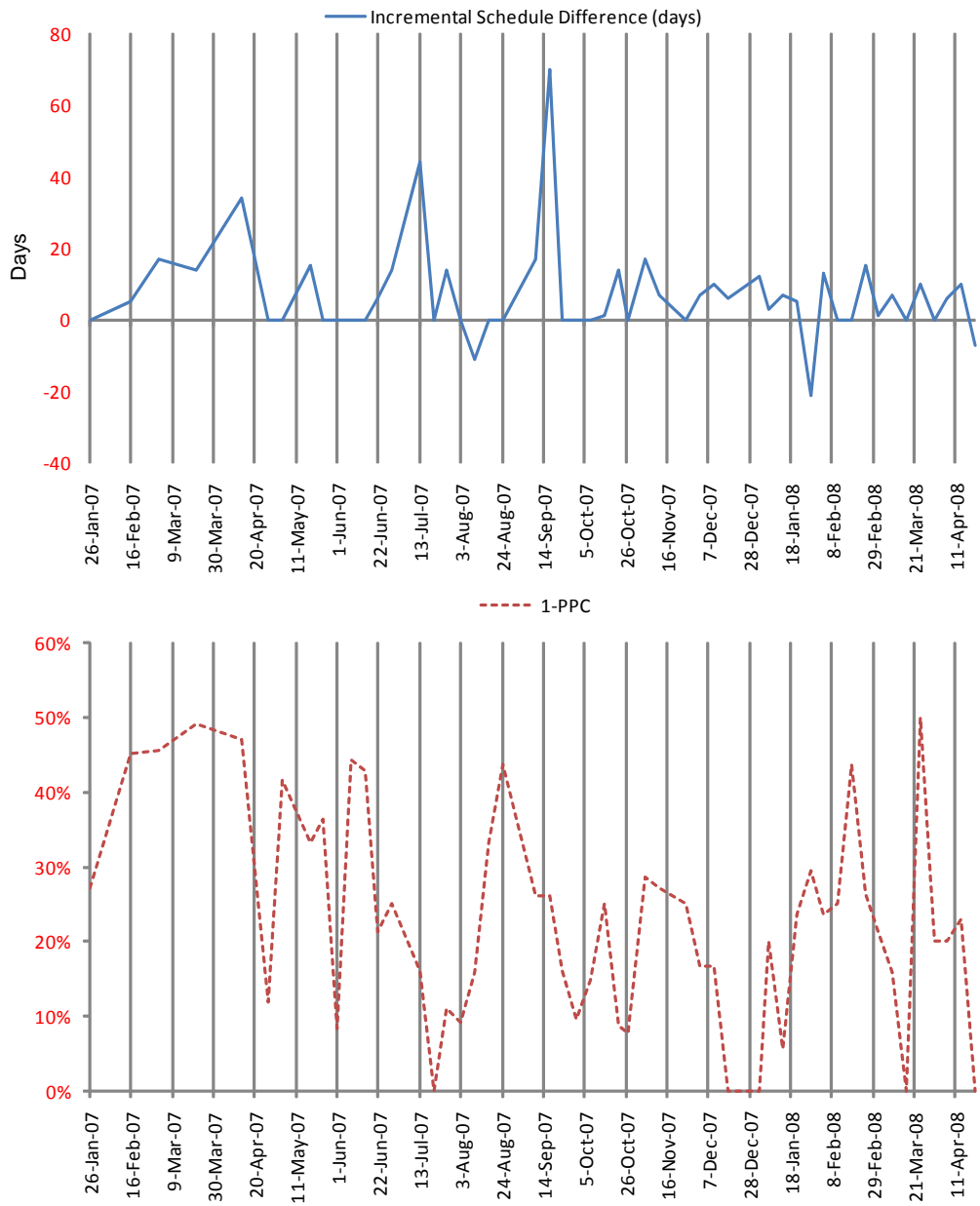

Figure 4.4: The relationship between percentage of work not complete (1-PPC) and incremental schedule difference for building ‘601’

Results show a low correlation between incremental schedule difference and (1-PPC) of 0.13 for building 601 and 0.12 for building 602. Figures 4.4 and 4.5 show inconsistencies in the relationship between these two variables including: (1) high (1-PPC) and negative schedule difference, and (2) low (1-PPC) and large positive schedule difference.

In case 1, high (1-PPC) shows poor performance in completing planned weekly tasks. If weekly work plans are well connected to the master schedule (i.e., planned tasks contribute directly to project progress and are mostly critical tasks) then a high (1-PPC) should have detrimental impacts on project progress showing large positive differences from the previous schedule update. Therefore, the negative schedule differences reported in this case show poor linkage between weekly work plans and the master schedule.

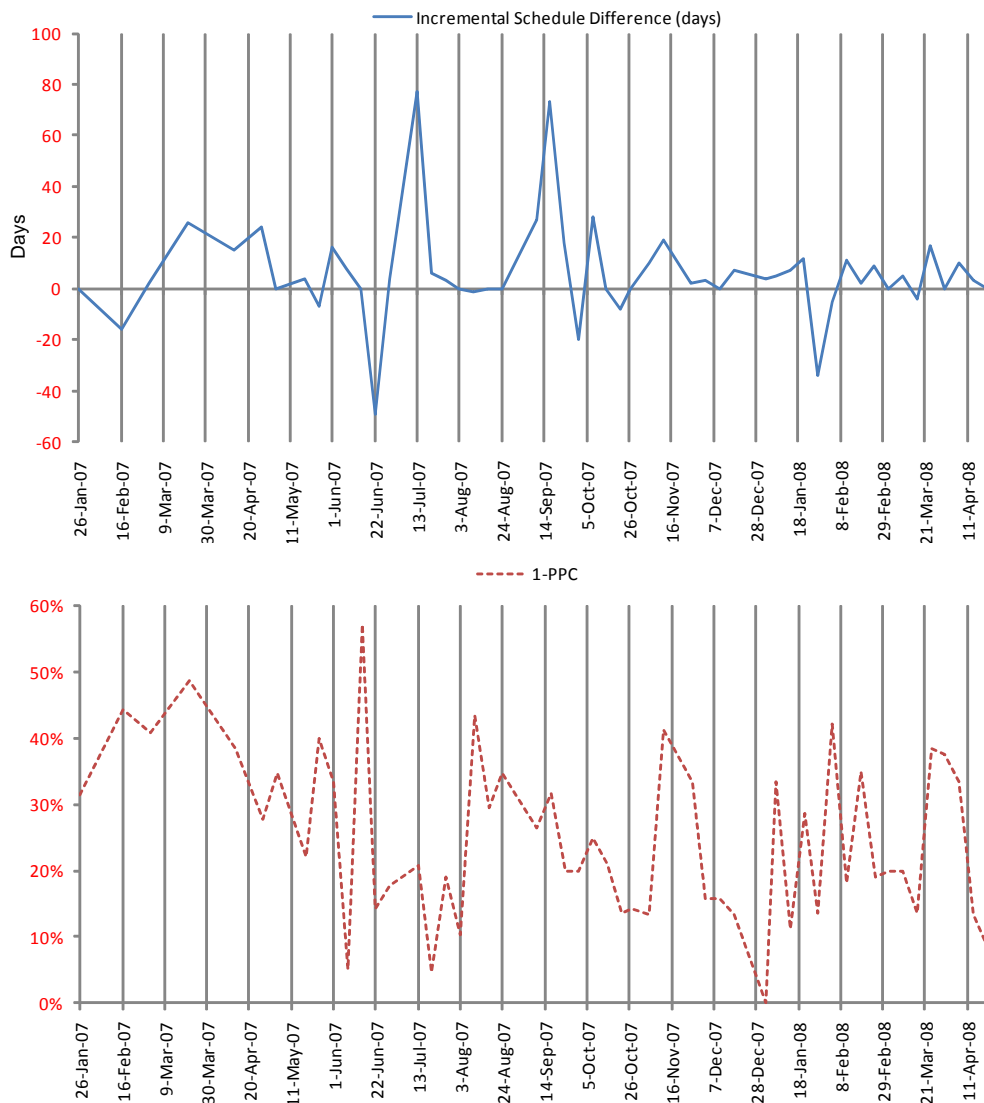

Figure 4.5: The relationship between percentage of work not complete (1-PPC) and incremental schedule difference for building ‘602’

In case 2, a low (1-PPC) shows that the construction team is performing all the planned tasks successfully. However, the project schedule is still slipping from one update to the next. Hence, weekly work plan tasks do not contribute to overall project performance suggesting that a substantial number of tasks are non-critical or out-of-sequence.

The master schedule update showed delays in finishing tasks of most buildings forcing these tasks to run in parallel (i.e., in comparison to the original plan where finishing tasks were more staggered) for most buildings toward the end of the project. This may suggest congestion of trades close to the end of the project where productivity and quality losses may have been incurred. However, in absence of productivity data, Figure 4.6 shows the actual cost expenditure for the rehabilitation part of the project over 14 months including the project handover in June 08. Although this graph should look more like a bell curve, it does not show huge expenditures towards the end of the project as one might expect to confirm congestion.

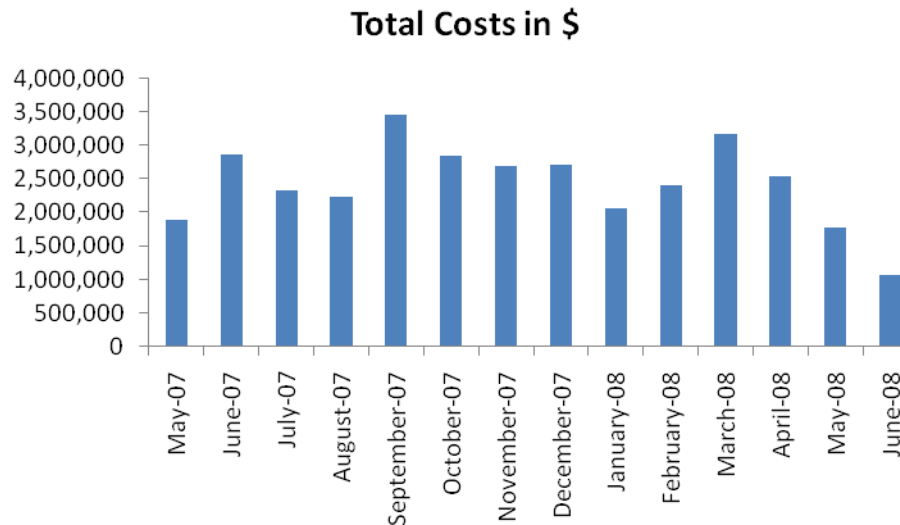

Figure 4.6: Project costs incurred by month on the rehabilitation section of the Fort Baker Retreat Project.

### **4.2.3 Conclusions**

The Retreat at Fort Baker project was successful in meeting the owner's expectations; finishing on time and under budget. The project is a great case study for studying and analyzing project planning processes. The signs of poor linkage between weekly work plans and the master schedule shown on this project are not foreign to other projects in the industry. The guidelines for lookahead planning presented in Chapter 5 were developed to mitigate such construction planning issues.

Although larger scope buildings including 601 and 602 started earlier, works on many of the buildings were running in parallel towards the end of the project. While the project finished on time, many trades were running in parallel towards the end of the project and productivity might have suffered. While Figure 4.6 does not confirm a spike in cost expenditure towards the end of the project, the project may have still suffered from productivity losses that would not show in Figure 4.6 especially when subcontractors have lump-sum contract agreements with the General Contractor. Thus, the lack of collected productivity data leaves the argument open to different interpretations.

## **4.3 UCSF's Cardiovascular Research Center**

### **4.3.1 Background**

The Cardiovascular Research Center (CVRC) is a 232,000 square foot building built for the University of California, San Francisco (UCSF) to house basic science researchers and physician-scientists in a common research center aiming to advance research and understanding of cardiovascular diseases. The five story building, designed by the Smith



Group Inc. (architect), is scheduled to open in 2011 with an estimated cost of \$181 Million (Rudolph and Sletten 2009).

Although the project's contractual structure is bound by a design-bid-build agreement, UCSF has been creative in looking for ways to enhance collaboration, information flow, and management processes on the project. Accordingly, the owner advocated the applications of several lean methods including the Last Planner<sup>TM</sup> System (LPS) for production planning and control.

To insure timely completion of the project, the owner is offering an incentive plan for the General Contractor (Rudolph and Sletten) and major subcontractors (e.g., mechanical and electrical subcontractors). The monetary incentive plan is divided equally between two targets. The first target involves meeting eleven schedule milestones shown on the master schedule developed by the General Contractor (GC) and approved by the owner. The second target, related to the application of the LPS, specifies a minimum percent plan complete (PPC) of 76%.

While the first target assures timely completion of milestones that express progress on the overall project schedule, the second target rewards acceptable performance in production planning, reliable construction workflow, and the completion of weekly tasks.

#### ***4.3.2 Implementing the Last Planner<sup>TM</sup> System***

The GC started applying the LPS for the construction phase in June, 2008 involving all subcontractors on the project. Because most of the project parties were not conversant in the LPS, the GC organized training sessions to familiarize the team with lean principles and the LPS for production planning and control.

While the GC maintained the master schedule in Primavera P6, weekly work plans were built initially in Excel spreadsheets. The weekly work plan was extracted from the master schedule and communicated to the team. PPC was calculated on a weekly basis and reported to the team during weekly work plan meetings.

While the use of Excel spreadsheets was convenient to advance tasks from the master schedule and build them into the weekly work plan, it provided limited flexibility to: (1) involve subcontractors in production planning and control, (2) provide real time feedback, and (3) connect the master schedule to weekly work plans. Accordingly, the GC incorporated the use of TOKMO, an online platform for schedule and Building Information Modeling (BIM) communication, to better enable the application of the LPS and establish a collaborative planning environment.

Figure 4.7 maps the planning processes performed at CVRC. The master schedule, built by the GC and approved by the owner, is used as reference for project planning. This schedule includes eleven major milestones monitored by the owner who is offering monetary incentives for meeting these milestones. The GC organized several pull sessions to plan / map milestones and phase tasks. Results of these pull sessions were later incorporated into the master schedule built in P6.

The weekly cycle starts each Thursday when the GC updates the master schedule in P6 and then extracts a three-week lookahead plan into TOKMO. The last planners (team leaders) of all subcontractors and the GC access the online TOKMO platform to: (1) update the schedule, (2) create work-streams (i.e., breakdown tasks into further detail and add new tasks), (3) commit to tasks for next week, (4) explain causes for deviating

from last week's work plan (display the cause for plan failure), and (5) identify constraints impacting future tasks.

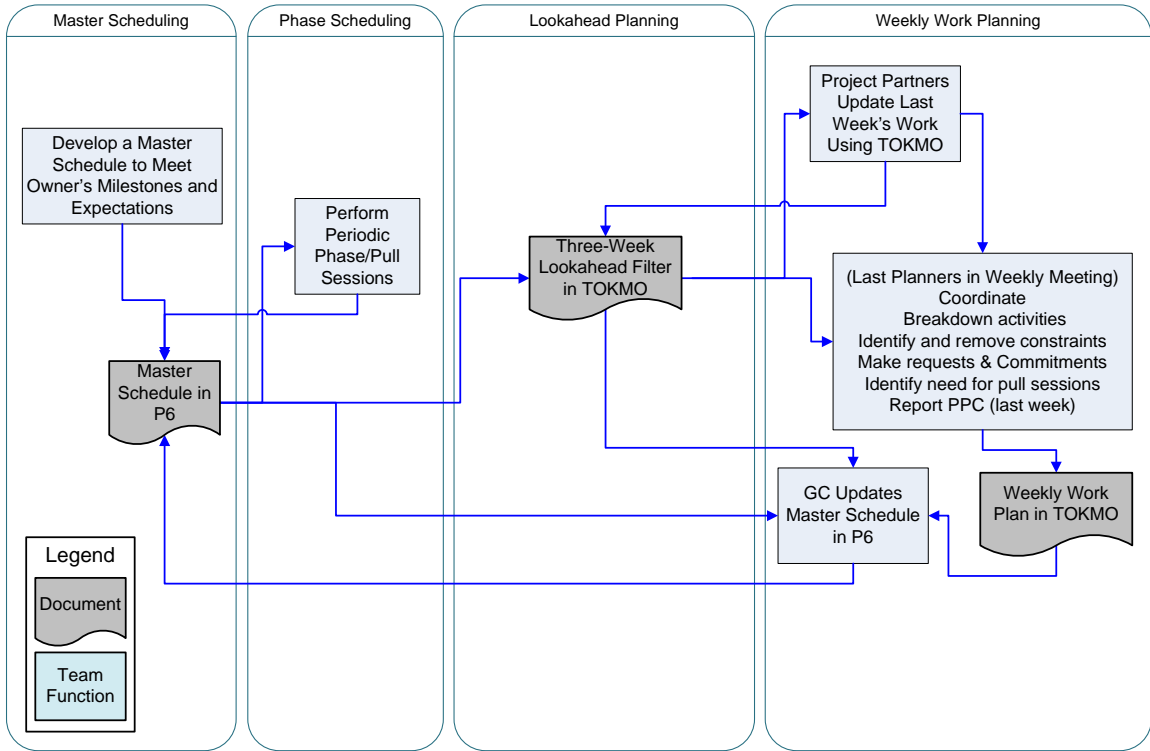

Figure 4.7: Implementing the LPS on UCSF's CVRC

The last planners use the weekly work plan meeting as a platform for coordinating, discussing, and negotiating the weekly work plan. The last planners also discuss site logistics, highlight constraints impacting planned tasks, and initiate the discussion for constraint removal. This marks the end of the weekly planning cycle which starts again with a new master schedule update. Figure 4.8 shows the planning cycle and highlights the planning steps performed by the project team on a weekly basis.

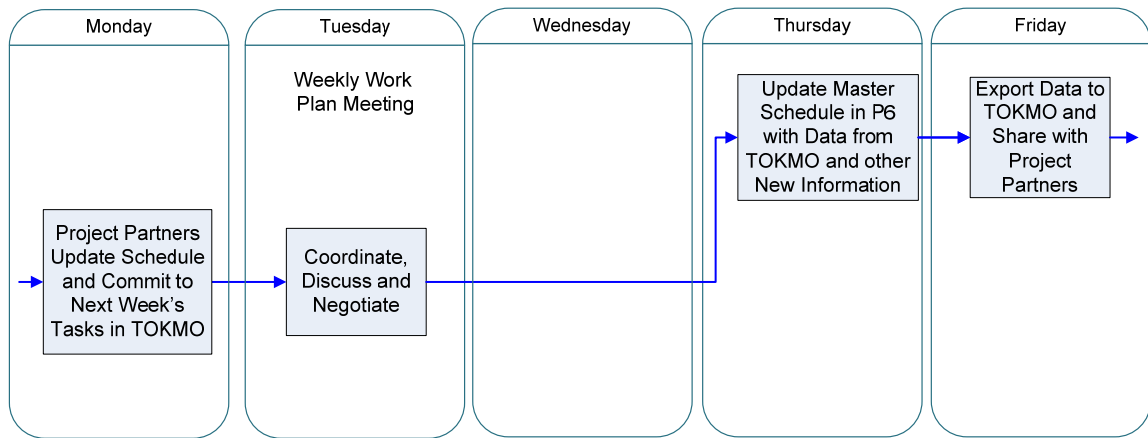

Figure 4.8: Weekly planning steps on CVRC.

### 4.3.3 Conclusions and Process Critique

The planning process implemented at CVRC is a bold attempt at implementing integrated project delivery methods in somewhat traditional design-bid-build environment. Spurred by the owner's interest in lean methods, the GC took on the challenge of implementing a new planning process to involve all project parties. This involvement was evident in phase / pull sessions, in the open use of TOKMO, and in weekly work plan meetings.

In addition to enabling collaborative project planning, the use of TOKMO allowed a near real-time feedback from project partners to the master schedule. Updating the master schedule in P6 on weekly basis and exporting it into TOKMO for all project parties to study, update, plan, and adjust in real-time is as close as it has been reported on construction projects to real-time feedback to a master schedule built in Primavera. While the project parties had complete freedom to access and manipulate the three-week lookahead plan exported to TOKMO, the GC remained the guardian of the master schedule in P6 controlling what information is sent in and out.

One major advantage of using TOKMO is that all project parties can access the master schedule built in Primavera through TOKMO. Although the only change(s)

subcontractors can make is to their tasks, they can print the schedule, look at relationships and logic, and develop a holistic understanding of the project schedule. These changes are approved by the GC before they are incorporated into Primavera.

The GC faced many challenges in implementing the planning process shown in Figure 4.7 including: (1) inexperience with the LPS, (2) introduction of a new technology, and (3) resistance to change.

Although the inexperience of most project parties in lean methods and the LPS is an impediment to collaborative planning, teamwork, and constraint removal, the GC lead the team to changing the traditional methods of project management. These traditional methods rely heavily on contractual structure and functional silos inhibiting coordination and collaboration. Training sessions and the GC's conduct during collaborative planning meetings helped send the right message and bring the rest of the team on board.

In addition to challenges related to implementing a new planning process, introducing a new technology created additional complications. The GC had to work meticulously with TOKMO developers to customize the software to match project needs. A sizeable accomplishment in this field, is enabling TOKMO to export tasks from P6 and at the same time import new additions or adjustments built into the three-week lookahead plan back into the master schedule in P6.

Resistance to change is inherent to implementing novel process in any organizational setting. The project parties struggled to use the new software and perform the planning steps dictated by the new process including: (1) updating the schedule, (2) creating work-streams, (3) committing to future tasks for next week, (4) explaining causes behind plan failures, and (5) identifying constraints.

While the project took big strides in moving away from non-lean traditional project management methods, there is always room for further improvement. The following is a list of suggested improvements: (1) greater involvement of project parties in weekly work planning (e.g., more participation in developing the plan using TOKMO not just updating last week's work plan, and more involvement in weekly work plan meetings), (2) further customization of TOKMO to perform CPM analysis when developing the weekly work plan without the need to export it to P6, and (3) further training for the project team on the principles of lean and the LPS.

#### **4.4 References**

- Hofmann, A. (2008). Personal Communication, Cathedral Hill Hospital Project, San Francisco, CA, November 20<sup>th</sup>.
- Quakenbush, G. (2008). "Historic Restoration: Cavallo point- The Lodge at the Golden Gate", *North Bay Business Journal*, Santa Rosa, Ca, 15 December, 3 pp.
- Rudolph and Sletten (2009). "Collaborative Methods Build a Cardiovascular Research Center", *Hooked on Construction*, Rudolph and Sletten - General and Engineering Contractor's Journal, spring, pp. 5-8.
- Sparapani, A. (2008). Personal Communication, Cathedral Hill Hospital Project, San Francisco, CA, November 27<sup>th</sup>.
- The Boldt Company (2008). "Sutter Regional Medical Foundation", *Company Brochure*, The Boldt Company, 1 pp.

## ***CHAPTER 5 - SUGGESTED FRAMEWORK FOR PRODUCTION PLANNING AND CONTROL***

Chapter 5 presents a suggested framework for implementing the Last Planner™ System (LPS) in construction. While it builds on previous work by Ballard et al. (1999a), Ballard et al. (1999b), Tommelein and Ballard (1997), and Macomber and Howell (2003), Ballard and Hamzeh (2007), it presents an update of the LPS as it evolves to meet challenges in production planning and control.

The framework presents operational guidelines for implementing the LPS combining two intertwining processes inherent to production planning ‘work structuring’ and ‘schedule development’ as defined in section 4.3. I developed additions to the previous versions of the LPS on the basis results of the case study research discussed in Chapter 3 and Chapter 4.

This chapter starts by laying out the context of LPS and presenting an overview of the system. The later sections describe the four planning processes that combine to form a system: master scheduling, phase scheduling, lookahead planning, and weekly work planning. This chapter ends with suggestions for organizations preparing projects for implementing the LPS.

### **5.1 Why the Last Planner™ System?**

The traditional approach to managing production in the construction industry emphasizes the use of project controls to reduce variances from established schedules or budgets, creates a contract-minded culture, and advances a push-based culture. At the same time, construction projects suffers from: a myopic view of parties due to the lack of global

optimization efforts, high levels of wastes in various forms, lack of communication and transparency, low customer satisfaction, and most importantly high variability in operations (Vrijhoef and Koskela 2000, Hopp and Spearman 1996, Hopp and Spearman 2008, Green et al. 2005).

Lean construction advocates collaborative production planning and execution emphasizing: maximizing workflow reliability, maximizing value for the customer, and minimizing waste (Howell and Ballard 1998). One of the main research streams in lean construction, focusing on reducing the negative impacts of variability and increasing reliability of workflow, has led to the development of the LPS.

Responding to the challenges and deficiencies of traditional production planning and control in construction, the LPS embodies the following planning practices: (1) planning in greater detail as you get closer to performing the work, (2) developing the work plan with those who are going to perform the work, (3) identifying and removing work constraints ahead of time as a team to make work ready and increase reliability of work plans (4) making reliable promises and driving work execution based on coordination and active negotiation with trade partners and project parties, and (5) learning from planning failures by finding the root causes and taking preventive actions (Ballard 2000a, Ballard et al. 2007, Ballard et al. 2009).

Previous research has underlined the positive impact of the Last Planner™ System on workflow variation and labor productivity (Ballard and Howell 1994, Alarcon and Cruz 1997, Ballard and Howell 1998, Ballard et al. 2007, Liu and Ballard 2008). However, research results presented in chapters 1, 3 and 4 highlight many issues and



challenges within the current practice. This chapter presents an update of the evolving LPS and aims at attending to these issues and challenges.

## **5.2 Overview of the Last Planner™ System**

The Last Planner™ System was developed by Glenn Ballard and Greg Howell as a production planning and control system to assist projects in smoothing variability in construction work flow, developing planning foresight, and reducing uncertainty in construction operations. While the system started as a production planning tool to manage workflow at the weekly work plan level, it soon expanded to become a production planning and control system combining four main planning processes: (1) master scheduling, (2) phase scheduling, (3) lookahead planning, and (4) weekly work planning.

Figure 5.2 shows the Last Planner™ System with its four levels of planning processes with different chronological spans: master scheduling, phase scheduling, lookahead planning, and weekly work planning. Figure 5.3 presents a process map highlighting major steps people (planners) must perform during project planning and control as advocated by LPS. Section 5.4 describes LPS in detail elaborating on specific tasks carried out during each planning process.

1- Master Scheduling, the first step in front-end planning, translates owner's value proposition into a master schedule describing work to be carried out over the entire duration of a project. It identifies major milestone dates and involves project-level activities mostly in relation to contract documents (Tommelein and Ballard 1997).

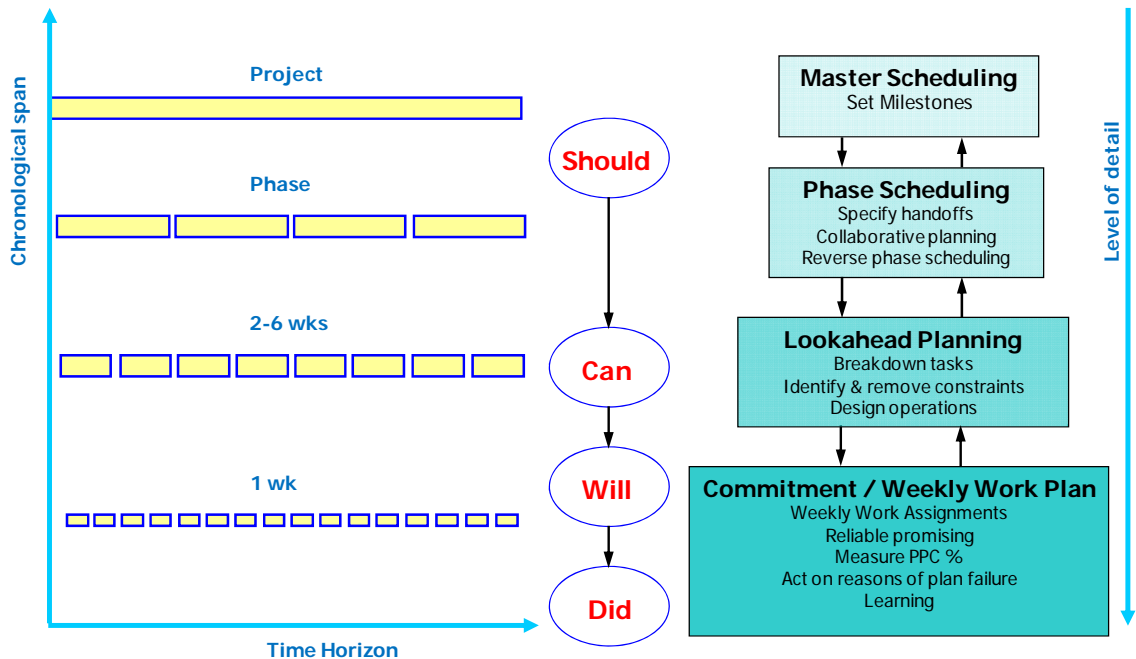

Figure 5.2: Planning stages/levels in the Last Planner™ system for production planning and control (Adjusted from Ballard 2000a).

2- Phase scheduling generates a detailed schedule covering all project phases and describing what tasks “Should” be done. In a collaborative planning setup, phase scheduling employs reverse phase scheduling and identifies handoffs between the various specialty organizations to find the best way to meet milestones stated in the master schedule (Ballard and Howell 2004). This is a progressive detailing of the master schedule, phase by phase.

3- Lookahead planning, the first step in production planning, uses screening and pulling to make tasks that “Should” be done into tasks that also “Can” be done. Constraints are identified and responsibilities are assigned for their removal. Tasks are broken down from the process to the operation level of detail and those operations are designed to safety, quality, time, and cost requirements (Ballard 1997).

4- Weekly work planning drives the production process (these plans could span a week or other time frame e.g., some construction projects have moved toward daily work planning). Plan reliability at the weekly work planning level is promoted by making only quality assignments and reliable promises to shield production units from variability in upstream tasks. Percent plan complete (PPC), a metric used to track the performance of reliable promising, measures the percentage of tasks completed relative to those planned. It helps assess reliability of weekly work plans and initiates preparations to perform work as planned. Analyzing reasons for plan failures and acting on these reasons is the basis of learning (Ballard 2000a).

The Last Planner<sup>TM</sup> System combines aspects from both deliberative and situated action models (Suchman 1987 and Senior 2007). In describing a premeditated rigid course of action in setting milestones and identifying handoffs, master and phase scheduling involve quite a bit of deliberative planning. Lookahead and weekly work planning are closer to the situated planning model where plans take into account changes in the environment affecting inputs and outputs of construction activities.

### **5.3 Work Structuring and Schedule Development**

While variability and uncertainty are inherent to project processes, production systems can be designed to manage uncertainty and reduce the negative impacts of variability. A production system can be defined as a collection of people and resources (e.g., machinery, equipment, information) dedicated for designing/making goods or services to meet customers' value expectations (Ballard et al. 2007).

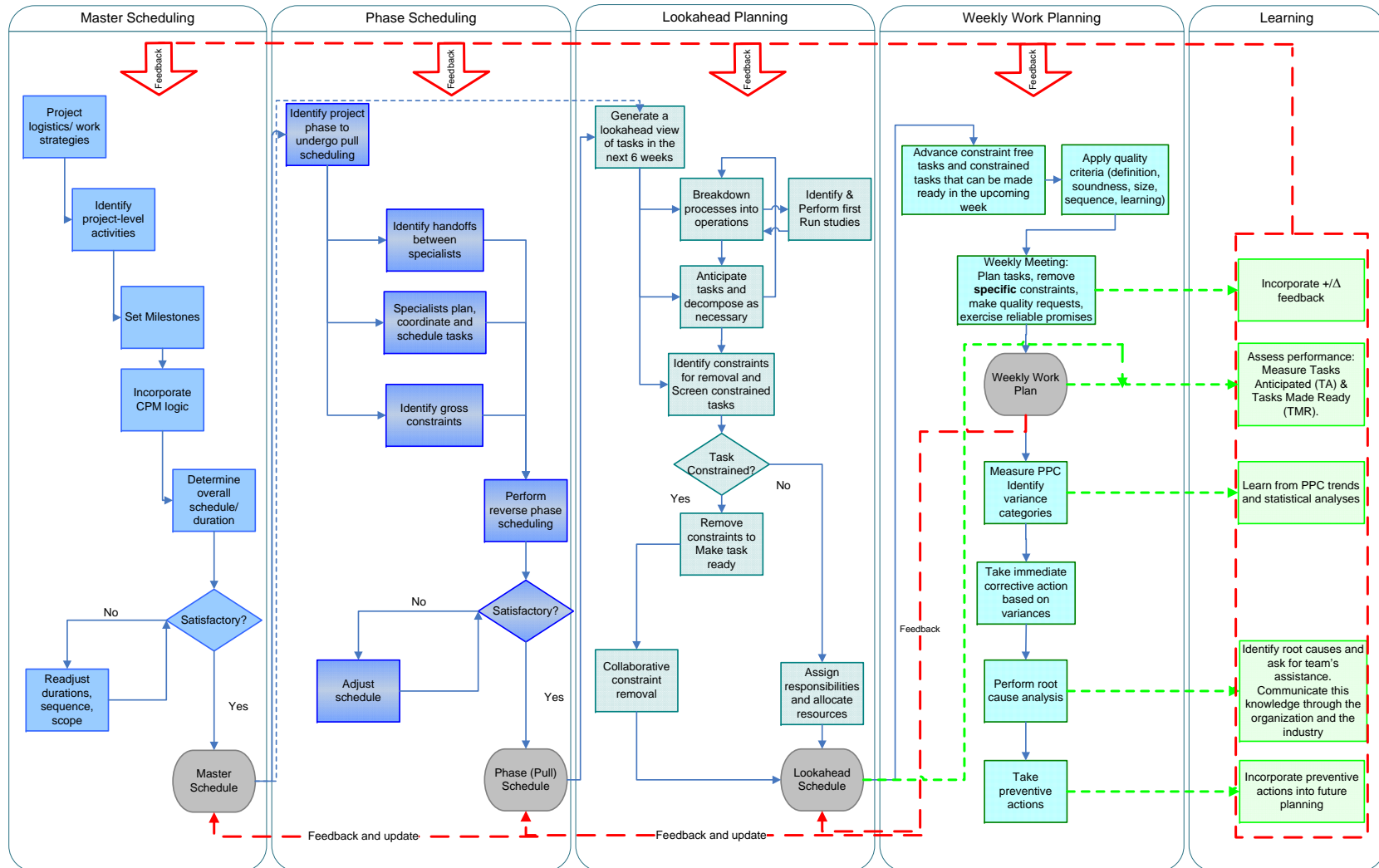

Figure 5.3: The Last Planner™ System (adopted from Ballard and Hamzeh 2007)

A component of production system design is “work structuring” which can be defined as developing product design in alignment with process design, structuring supply chains, allocating resources, and designing offsite preassemblies to realize a reliable workflow and maximize customer value (Ballard 2000a and Tsao et al. 2004).

Work structuring covers an entire production system from major milestones down to operations performed on materials or information within the system. Work structuring differs from work breakdown structure (WBS) which was traditionally used by planners to decompose a project into work packages, build it into a project schedules, and use it for project control.

Work structuring answers the following questions:

- (1) In what units will work be assigned to work groups?
- (2) How will work units be sequenced?
- (3) How will work be released from one work group to the next?
- (4) Will consecutive work groups execute work in a continuous flow process or will their work be decoupled?
- (5) Where will decoupling buffers be needed , where should they be located, and how should they be sized?
- (6) When will different units of work be executed? (Howell et al. 1993, Ballard et al. (1999a), Ballard et al. (1999b), Tsao et al. 2004, Ballard and Hamzeh 2007).

Figure 5.4 shows work structuring as an ongoing dynamic process spanning the whole project life cycle from early project definition through design, supply, assembly and use (Ballard 2006).

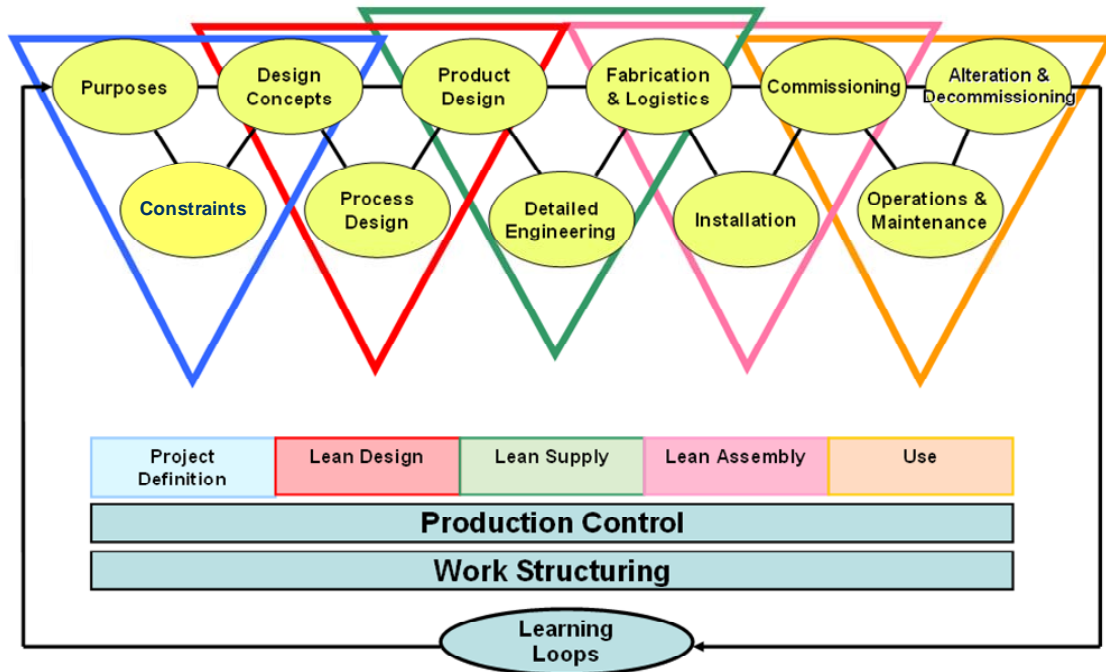

Figure 5.4: Work structuring within Lean Project Delivery System (Ballard 2006)

Work structuring involves the development of various project planning and control processes including: (1) build work execution strategies ( e.g., start with tower structure and build parking structure later), (2) develop project organizational structure (divide project into areas), (3) configure supply chains (e.g., supply chain for curtain wall glass/aluminum units), (4) design rough-cut operations (e.g., cast-in-place versus precast concrete panels), (5) design detailed operations (e.g., formwork for concrete core walls) and (6) develop milestone schedules (Ballard et al. (1999a,1999b), Ballard and Hamzeh 2007).

Work structuring works hand in hand with ‘Schedule Development’ which can be defined as the planning process that translates owner’s value proposition into operational work plans. Schedule development intertwined with work structuring: (1) develops phase schedules based on master schedule, (2) designs lookahead plans grounded in pull and

phase schedules, and (3) produces weekly work plans of task made ready during lookahead planning.

Figure 5.5 presents schedule development using the LPS from phases (boulders) to processes (rocks) then to operations (pebbles) across four planning processes resulting in four levels of schedules: (1) master schedule, (2) phase schedule, (3) lookahead plan, and (4) weekly work plan. Section 5.4 elaborates on the schedule development process.

Figure 5.6 presents an example of task break down from phases to steps for a hospital. The project comprises many phases including: substructure, superstructure, and finishes. A phase can be broken down into many processes; for example ‘superstructure’ can be broken down into build walls, slabs, and columns. A process such as ‘build walls’ may be broken down into operations such as formwork, installing rebar, and placing concrete. Operations can be further broken into steps which have small durations such as hours in a day, and often are assignments to individuals or sub-teams within a work group. Although steps can be broken down into motions, weekly work plans normally include tasks at the level of operations assigned to work groups but do not go into motions. Within a work group, responsibility for steps within an operation is assigned to individuals or sub-teams (e.g., handling the hose in a concrete placement operation is a step. Steps, which may have durations in minutes or even seconds, are shown on weekly work plans but are expressed in standardized work practices. For example, priming a concrete pump is a standardized task when placing concrete, although it does not show up on weekly work plans.

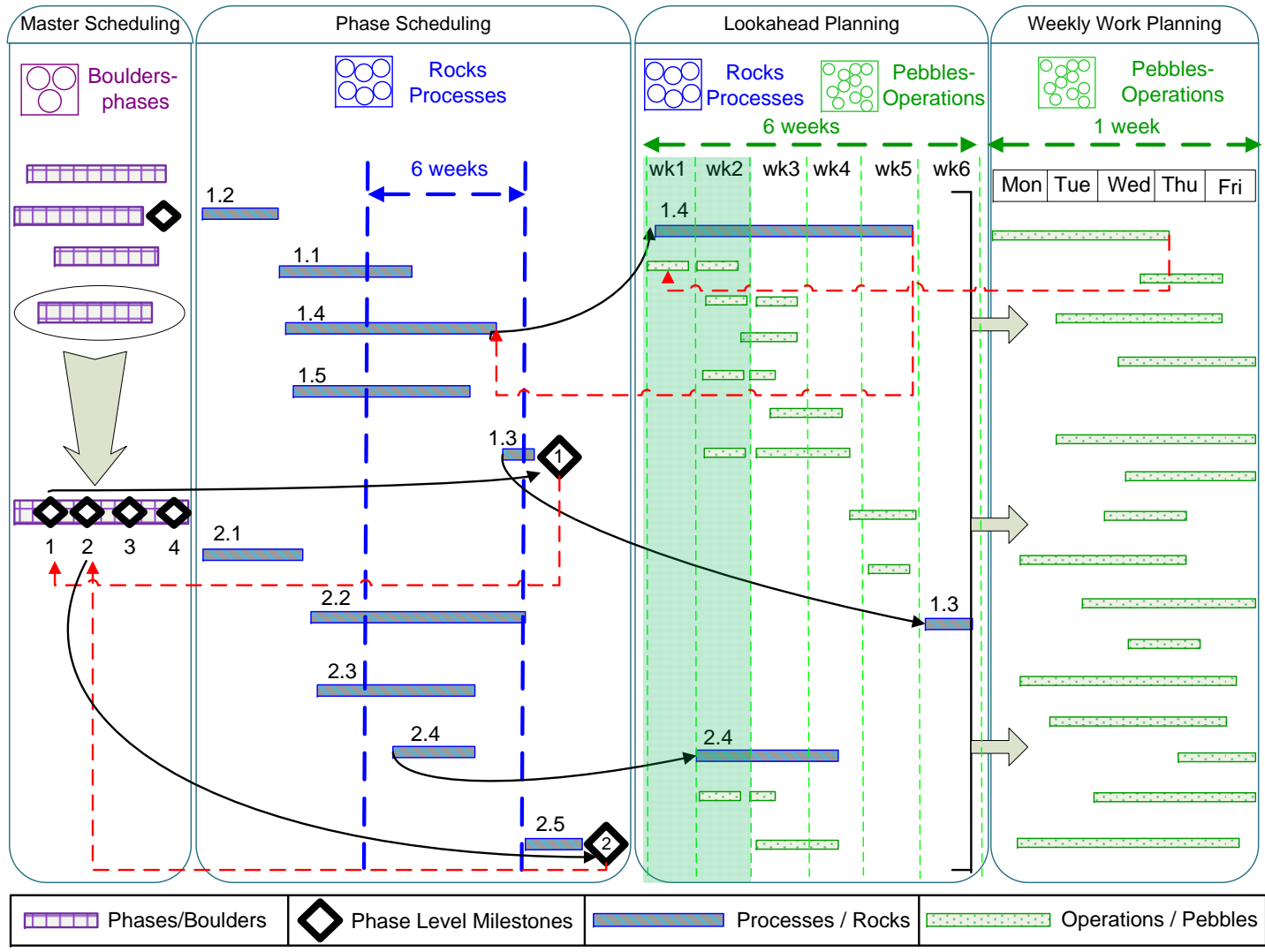

Figure 5.5: Schedule development and work structuring in LPS.



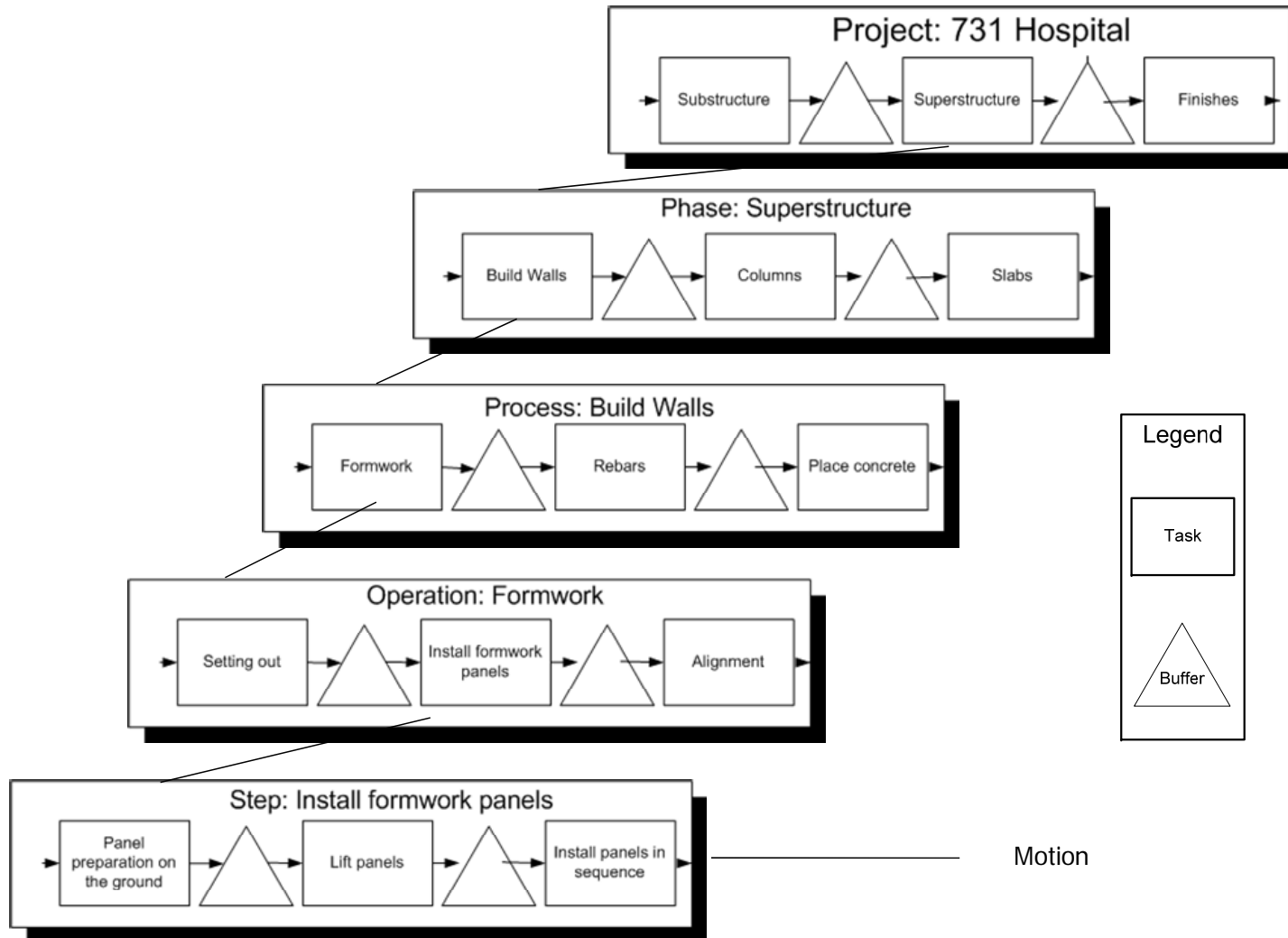

Figure 5.6: Breaking down tasks to the level of operations and steps (after Ballard 2000a)

## **5.4 The Last Planner Process**

This section presents a detailed description of each of the four LPS processes. The system works best when all these processes are developed in sync (i.e. schedules are compatible), involve project stakeholders, account for dynamic changes/updates, and utilize learning from planning failures for continuous improvement.

The process starts with front end planning when a master schedule is developed to translate the owner's value proposition into milestones. Phase scheduling utilizes pull techniques to define handoffs for delivering milestones. Production planning starts with lookahead planning which employs screening and pulling to make tasks ready for execution. Weekly work plans, which directly drive the production process, are produced from a backlog of constraint-free tasks and also tasks that can be made ready during the week. Applying quality criteria when developing a weekly work plan, exercising reliable promises, and learning from plan failures all combine to shape plan reliability.

### ***5.4.1 Master Scheduling***

Master scheduling is the first process in front-end planning; it translates the owner's value proposition into a master schedule describing work over the entire duration of a project. It involves project-level activities mostly in relation to contract documents (Tommelein and Ballard 1997, Ballard et al. 1999a). These high level activities, expressed as boulders, describe milestones, which in turn define project phases.

As Figure 5.7 shows, master scheduling starts by translating the owner's values and purposes (value proposition) into work plans and execution strategies which are expressed in project level activities (boulders). The dialogue between the owner's values

and work strategies produces the foundation for setting project milestones. After identifying major milestone dates, critical path method (CPM) logic is used to determine overall project duration (Tommelein and Ballard 1997). CPM logic can be represented in different forms including Gantt, PERT (Program Evaluation Review Technique), and line of balance diagrams.

The calculated project duration and the timing of milestones are checked against the owner’s expectations. If found unsatisfactory, alternatives or adjustments to the original schedule in terms of duration, sequence, or scope are introduced and re-planning performed until a satisfactory schedule is developed. This schedule is called the master schedule.

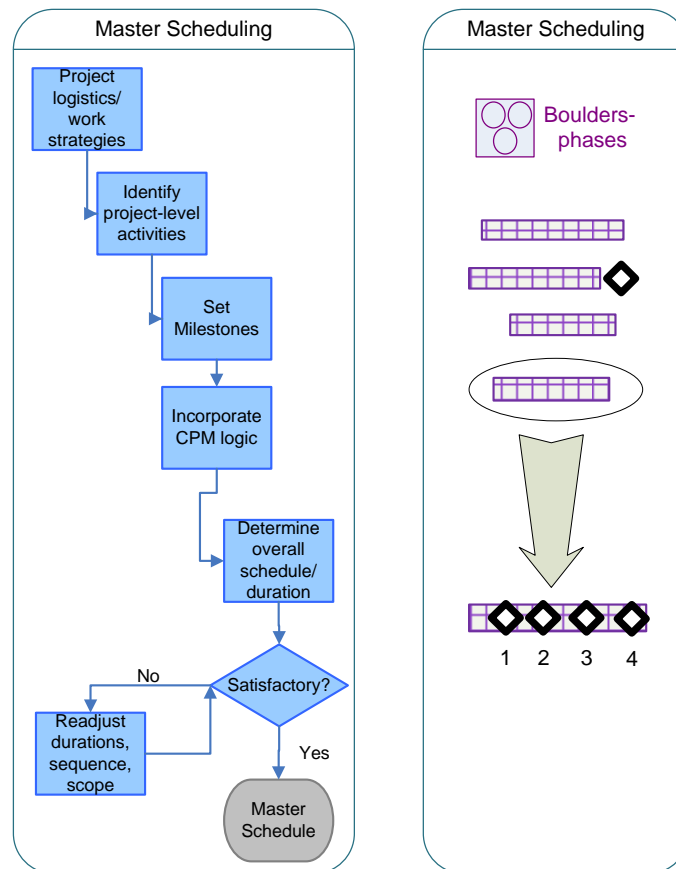

Figure 5.7: The master scheduling process in the LPS

When project stakeholders are engaged early in the project, as when employing integrated project delivery, the master schedule can be developed collaboratively incorporating feedback from project parties who have already been engaged in the project at that stage.

#### ***5.4.2 Phase Scheduling***

The purpose of phase scheduling is to produce a plan for meeting a milestone or completing a phase while maximizing value generation and establishing support from project stakeholders. Scheduled activities are then drawn from the phase schedule into the lookahead process, broken down into operations, and made ready for execution in weekly work plans (Ballard et al. (1999a,1999b), Ballard and Hamzeh 2007).

Linking work structuring to production control, phase scheduling produces a phase schedule communicating handoffs and goals to which to steer production. In a collaborative planning setup the phase schedule, also called pull schedule in the industry, identifies handoffs between project parties and employs reverse phase scheduling to find the best way to meet milestones shown on the master schedule. Phase scheduling often results in introducing adjustments to original CPM logic as needed to meet project goals (Ballard et al. (1999a,1999b), Ballard and Howell 2004, Ballard and Hamzeh 2007).

On large and complex projects, the master schedule includes many milestones and high-level tasks that express project phases. Figure 5.8 shows that the first step in master scheduling is identifying milestones delimiting phases that must undergo collaborative pull scheduling. Phase or pull scheduling is a collaborative process that a team can use to plan the delivery of a phase of work (to plan the accomplishment of a schedule milestone) according to customer pull or value expectations.

Pull scheduling works backwards from a target completion date. Tasks are defined and sequenced to release work to downstream tasks when they are requested / pulled, thus achieving a handoff. Pull scheduling works backwards from a target completion date to eliminate work that may not add value and reducing the waste of overproduction (Ballard et al. (1999a,1999b), Ballard and Hamzeh 2007).

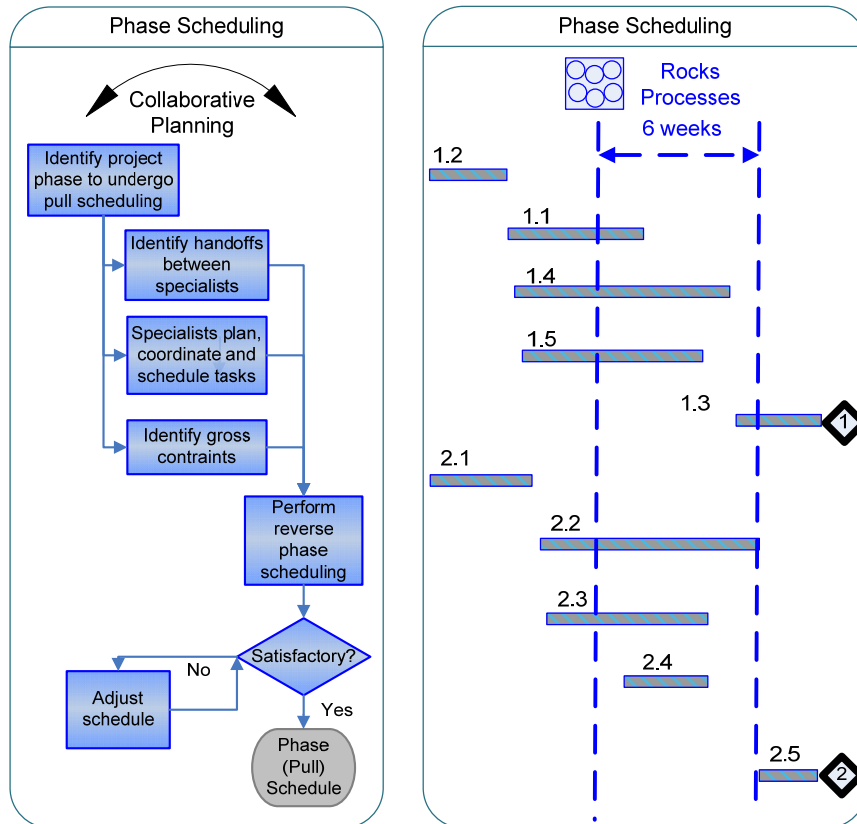

Figure 5.8: The phase scheduling process in the LPS

When identifying phases to undergo phase scheduling, it is essential to align the perspectives of various project partners unifying the team’s expectations to what value needs to be delivered when executing this milestone. This step, called ‘milestone alignment’ in this study, starts by identifying deliverables or outcomes of value to downstream customers, followed by expressing and communicating the conditions of satisfaction for the outcome to be delivered by a partner upstream to another project

partner downstream. Conditions of satisfaction result from negotiations / discussions between the parties. Setting tough time-targets often encourages such negotiations / discussions. Milestone alignment results in a better understanding of the milestone to be pulled, a date to pull to, and a set of handoffs between various specialists.

Collaborative or team planning engages representatives of all project stakeholders involved in a project phase. With handoffs or deliverables identified, team members begin team planning by writing on sheets of paper: (1) a brief descriptions of work they must perform, (2) expected unpadded duration, (3) resources employed, and (4) previous work to be completed by others to release work to them. It is recommended that the meeting participants prepare for the meeting by reviewing their work scopes and developing a preliminary work plan. The team then arranges the sheets on a wall in their expected sequence of execution. This exercise encourages team coordination as planning breaks out in the room and team members start developing new network paths, devising new methods, negotiating sequence, and considering different batch sizes (Ballard et al. (1999a,1999b), Ballard and Hamzeh 2007).

The next step is reverse phase scheduling starting from the milestone and moving backwards towards the start. Backward scheduling is helpful in uncovering constraints when team members have to think of prerequisites required to start an activity (Ballard 2000a). It is crucial at this stage to start uncovering gross constraints that impact a phase or a process within a phase.

While the phase schedule is developing, network logic is often readjusted and task durations altered to find the best way to meet the milestone or phase undergoing phase scheduling. A phase may be decomposed into interim milestones that can be used in pull

scheduling (e.g., super structure as a phase can be broken down to many interim milestones such as ‘first floor’, ‘second floor’, etc.). The resulting reverse phase schedule may take one of three possible forms: (1) a schedule that does not meet the allotted time frame, (2) a schedule that fits the time frame snug tight, or (3) a schedule that contains some float.

The schedule that results from backward pass process is satisfactory only when the scheduled tasks fit within the available time, with sufficient slack (float) to buffer critical and variable tasks. First attempts often do not meet time limits, as in the example shown in Figure 5.9; much less provide a schedule buffer; so re-planning is required.

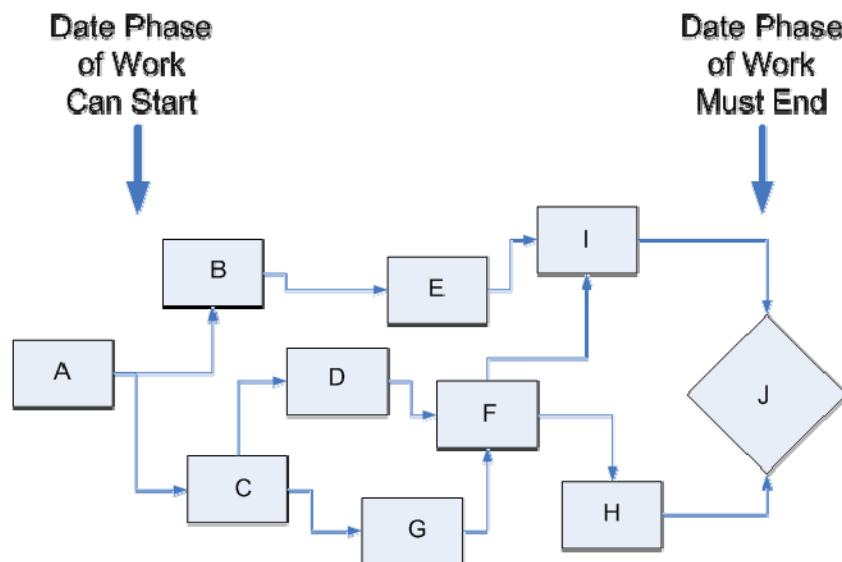

Figure 5.9: Reverse phase schedule exceeding limit limits (Ballard 2008)

To create an acceptable buffered schedule, the project team analyzes the network for possible changes in logic or task duration. The team may generate several ways to shorten time including: (1) starting more tasks in parallel (a matter of reducing the handoff batch size), (2) allocating resources differently, (3) and applying new methods or





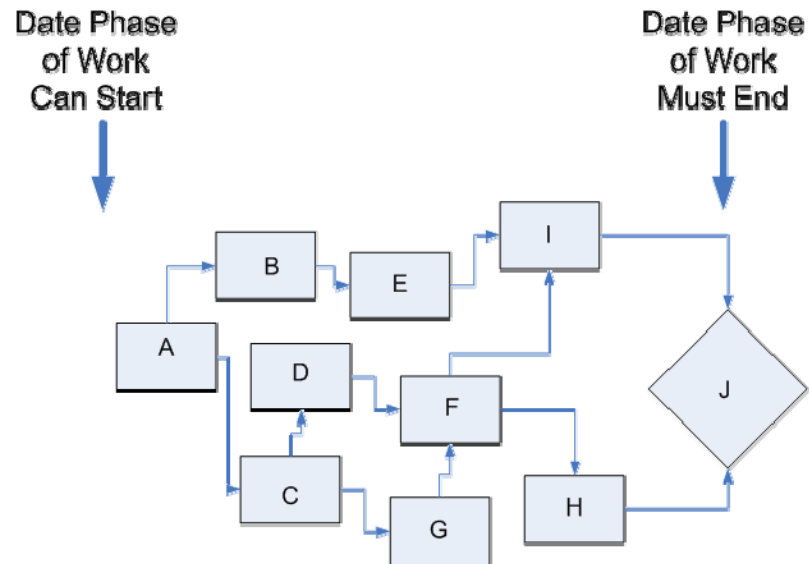

Figure 5.11: Reverse phase schedule after schedule buffer has been distributed (Ballard 2008)

Although the goal of phase scheduling is to find the best way to meet a milestone or accomplish a phase, sometimes this is not possible and in this case the phase completion date is allowed to slip out. The goal of phase scheduling should always be kept in mind: to generate a schedule that all project stakeholders buy into, define handoffs between specialists for control without going into too much detail, introduce required adjustments to CPM logic, and produce an executable schedule agreed on before the start of phase (Ballard et al. (1999a,1999b), Ballard and Hamzeh 2007).

### 5.4.3 Lookahead Planning

Lookahead planning is the first step in production planning and provides a link between the project schedule and short term commitments. It starts with generating a lookahead view from phase schedule and continues to weekly work planning. However as Figure 5.12 shows, lookahead planning means not just viewing near-term tasks from the master or phase schedule and possibly detailing them; rather, it is a process that involves: (1)

breaking down tasks into the level of processes/operations, (2) identifying and removing constraints to make tasks ready for execution, (3) and designing operations through first run studies (Ballard 1997, Hamzeh et al. 2008).

Lookahead planning is an essential process in production planning and control. It: (1) shapes the sequence and rate of work flow, (2) links master and phase schedules to weekly work plans, (3) shields downstream tasks from uncertainty in upstream tasks, (4) sizes work flow to match capacity and constraints, and (5) produces a backlog of workable activities by screening and pulling (Ballard 2000a, Ballard et al. 2003).

Screening subjects tasks to constraint analysis to identify actions needed now to make scheduled tasks ready so that they can be performed when scheduled, and to prevent commitment to tasks that cannot be made ready. Typical constraints are contracts, change orders, requests for information, design instructions, materials, predecessor tasks, labor, equipment, and space. Pulling dictates which tasks to make ready by removing constraints and ensuring the availability of prerequisites as per actual site demand. While pulling is built into the schedule that lookahead planning should start with, it is also present in the LPS rule that no tasks are to be imposed on work groups unless they are ready to perform them (Ballard 2000a, Hamzeh et al. 2008)

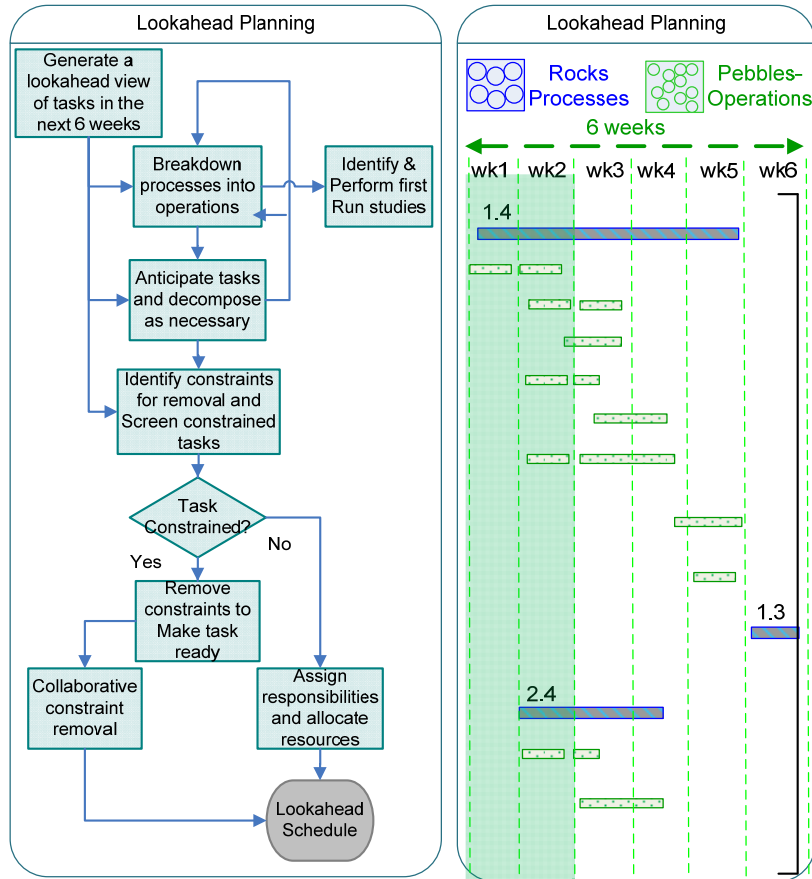

Figure 5.12: The lookahead planning process in the LPS

Lookahead planning starts by filtering a schedule that looks several weeks, most commonly six, into the future. Figure 5.13 lays out a six week lookahead process showing how the process evolves from six weeks away from execution until the execution week.

*Six weeks ahead of execution:* Tasks enter the six week lookahead plan from the phase schedule. At this stage, gross constraints are evaluated and a plan for removal is devised. Gross constraints are those that impact all instances of phase-level tasks and processes; i.e., to every operation that belongs to that type of process. An example is the production of fabricated items such as precast concrete panels. This process involves several operations: detailing, fabrication, and delivery. Fabrication is one operation in this

process, and will recur many times. For construction, typical gross constraints are materials and design information. Phase scheduling can act as a catalyst for identifying handoffs and gross constraints early on. Although removing constraints can take place anywhere within the six weeks on the lookahead plan, it is desirable to remove constraints two to three weeks prior to executing a task.

*Between five weeks and four weeks ahead of execution:* Activity break down starts by decomposing tasks into their elements, moving from processes to operations. Projects consist of phases, phases of processes, processes of operations, operations of steps, and steps of elemental motions. Elemental motions are not represented in current forms of the LPS, although they may be appropriate analytical units for design of highly repetitive tasks executed under controlled conditions. Steps are defined in the design of operations. Steps are tasks assigned to individuals or sub-teams within work groups.

As Figure 5.13 shows, “Boulders” are phases such as ‘superstructure,’ “Rocks” are processes such as ‘build walls,’ and “Pebbles” are operations such as “lay formwork.” “Dust” represents steps and motions and is not usually shown on production schedules but incorporated into standardized production operations such as “mark steel walers”.

Activity breakdown goes in parallel with defining operations, sequencing work in the most optimal way, coordinating tasks among project stakeholders, loading operations with resources, sizing load to match capacity, and analyzing tasks for soundness so that prerequisite inputs are ready such as previous work, information, material, labor, and space (Hamzeh et al. 2008).



*Three weeks ahead of execution:* By this time the team should have designed operations through first run studies, developed detailed plans for work execution, and screened out those tasks they are not confident can be made ready in time. A first run study is an actual performance of an operation for the first time in order to try out, study, learn, and improve the method to execute an operation. It involves understanding the work involved, the skills and resources needed, and the interactions with other operations. The process involves evaluating the devised plan, launching refinements, and establishing standardized work. Potential operations requiring first run studies are those that are new, critical, or repetitive (Ballard et al. (1999a,1999b), Ballard and Hamzeh 2007).

*Two weeks ahead of execution (WK2):* Lookahead plan activities are broken down and detailed as they move closer to execution. Accordingly, when activities are two weeks away from execution, they will match the detail required for production at the weekly work plan level. The level of detail in planning is time driven. It may be planning to the day, to the shift, or to the hour (e.g., planning of shutdown operations). Tasks that are constraint-free join the workable backlog (backlog of workable or ready tasks). Tasks on the workable backlog may be selected to join the weekly work plan if they meet the quality criteria as discussed next.

*One week ahead of execution (WK1):* At this stage, a provisional weekly work plan is prepared from (WK2) gauging tasks against quality criteria of definition, soundness, sequence, size, and learning (discussed in further detail in section 5.4.4). Tasks that are critical, made ready, or can be made ready in the upcoming week are incorporated in the weekly work plan within available capacity. Made ready and non

critical tasks are placed on the fall back / follow on work list to be performed in case of extra capacity, either from completing critical tasks sooner than expected, or from discovering a constraint that cannot be removed in the plan period.

#### 5.4.3.1 Tasks Anticipated and Tasks Made Ready

To monitor the performance of the lookahead process, two metrics are proposed: (1) Tasks Anticipated (TA) and (2) Tasks Made Ready (TMR). TA measures the percentage of tasks anticipated on the lookahead plan two weeks ahead of execution. TMR measures the performance of lookahead planning in identifying and removing constraints to make tasks ready for execution (Ballard 1997 and Hamzeh et al. 2008). TMR (i,j) measures the percentage of tasks anticipated on the lookahead plan i weeks ahead of week j, with week j being the week of execution (the week covered by the weekly work plan).

Figure 5.14 presents an example for calculating TA and TMR by showing: (a) a lookahead plan two weeks away from execution (WK2, 06/08/09), (b) a weekly work plan at the beginning of the execution week (WWP, 06/15/09), and (c) an executed weekly work plan at the end of the week (WK0, 06/20/09).

Dividing the number of tasks completed at WK0 (13) by those planned (18) (ignoring completed back log activities) gives an  $8/13 = 72\%$  PPC. Examining the weekly work plan (WWP) shows that out of the 18 tasks that made their way to the weekly work plan, only 14 were successfully anticipated on the lookahead plan two weeks away from execution (WK2). These 14 successfully anticipated tasks at (WK2) result in a TA of  $14/18 = 78\%$ . Comparing the lookahead plan two weeks away from execution (WK2) and the executed weekly work plan (WK0) shows that out of the 20

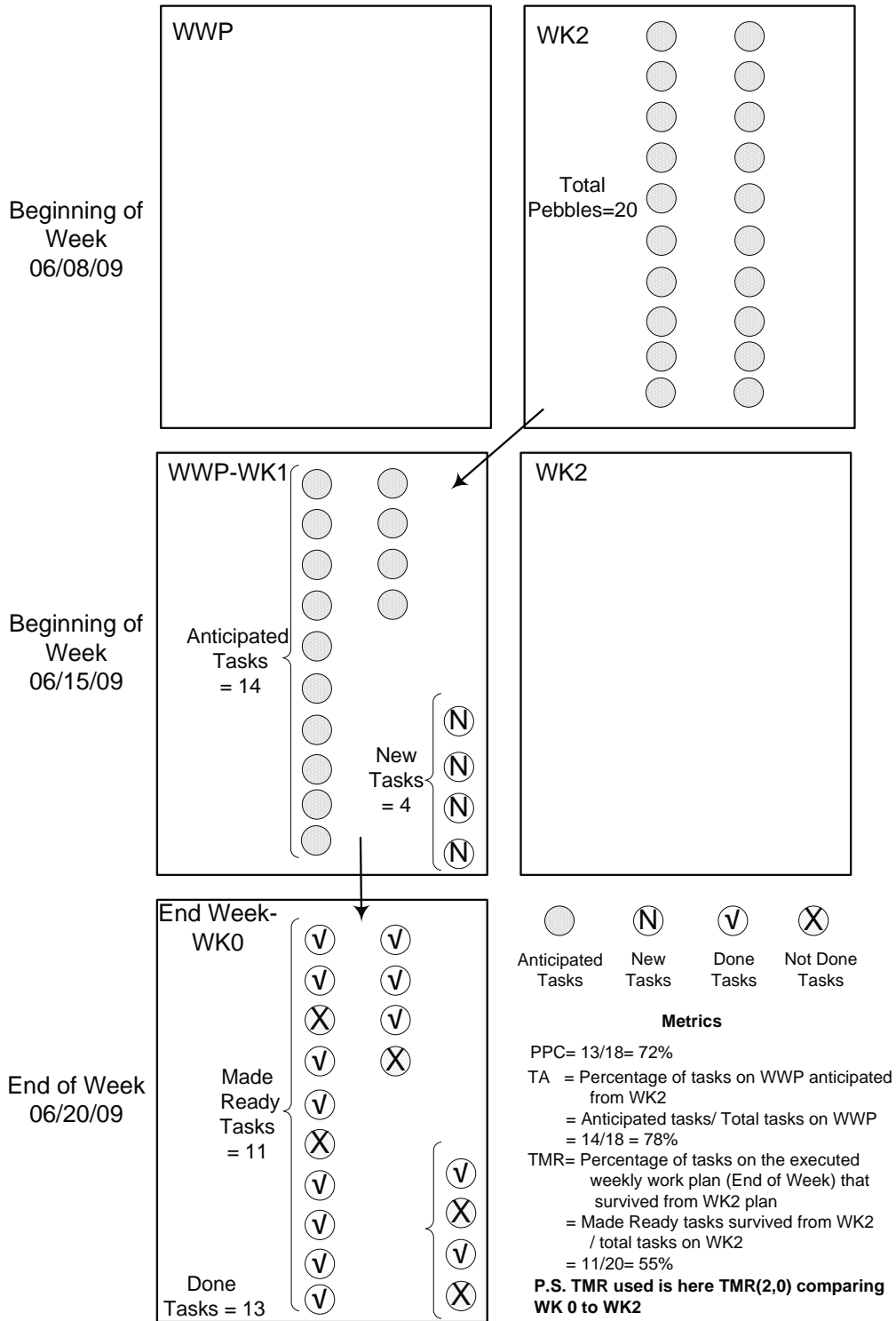

Figure 5.14: Measuring tasks anticipated (TA), tasks made ready (TMR), and percent plan complete (PPC).



tasks indicated on the lookahead plan only 11 have been completed or done, resulting in a TMR (2, 0) of  $11/20 = 55\%$ .

In measuring performance of lookahead process, TA and TMR indicate the production team's ability to plan ahead of execution. TA expresses foresight in anticipating tasks and identifying constraints. Establishing foresight is only one part of lookahead planning; it should be combined with screening, proactive removal of constraints, and prioritizing tasks for execution, which are captured by measuring TMR (Hamzeh et al. 2008).

#### 5.4.3.2 Constraints Analysis

Constraints identified during lookahead planning are either removed by securing commitments from a team member or carried over in a constraint log until they are assigned. A constraint can be defined as a limitation or restriction that prevents an activity or set of activities to take place. As Figure 5.15 shows, a constraint can be any prerequisite that an activity needs before or during execution such as: previous work, information, equipment, materials, human resources, funds, and conditions (e.g., weather and safety).

Make-ready actions are assigned to team members to remove identified constraints, and those actions become part of the current or future weekly work plan. Until a commitment is made to make-ready, the constraint is carried in a constraint log to monitor the status of constraints. To remove a constraint by a team member, the team assigns a make-ready task to that member after he commits to performing the work involved.

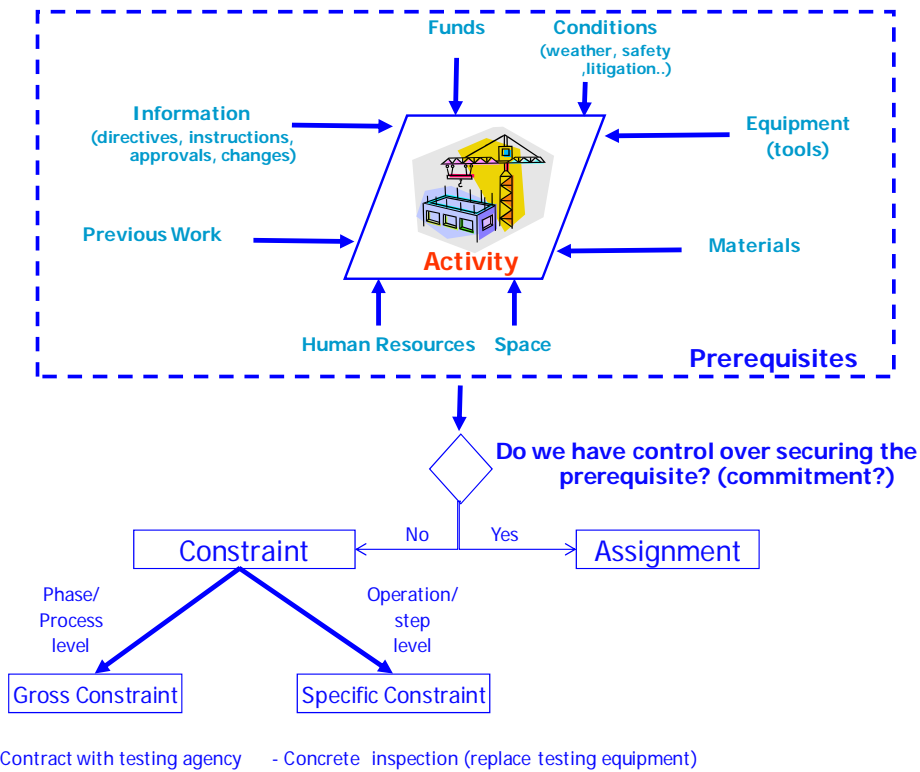

Figure 5.15: Gross and specific constraints

For example, activity “01123- Pour base slab” requires concrete delivery at 12:00 pm on Monday. If concrete delivery is under the team’s control, then the prerequisite can be removed by assigning a step called “order concrete” to the general foreman. However, if concrete delivery is outside of the team’s control, such as requiring a parking permit from municipality to enable delivering concrete to site, then it is considered a constraint. Although this constraint can be formulated into an assignment “obtain a parking permit”, the execution of the assignment is beyond our control. No commitments can be made, the duration is unknown to the team (though they may be able to estimate it), and resource allocation is outside the team’s scope.

Gross constraints can be differentiated from specific constraints by the level of planning detail. At the phase and lookahead level, scheduled tasks represent phases and processes. Constraints at this level are called “gross constraints”. An example of a gross

constraint is “establishing an agreement with testing agency” which might impact a whole phase. Specific constraints apply to operations or steps such as “replacing a piece of testing equipment to enable concrete testing” which impacts a specific operation at the weekly level.

#### ***5.4.4 Weekly Work Planning***

“Weekly work planning” is an extension of lookahead planning into the execution week (WK0). It represents the most detailed plan in the LPS and directly drives production. It is the level at which promises and commitments are made. In phase scheduling, team members are committing to do their best. In lookahead planning, team members are doing all they can to remove constraints. In weekly work planning, team members are committing to doing their tasks. Plan reliability at the weekly work planning level is promoted by making quality assignments and reliable promises to shield production units from uncertainty in upstream tasks. At the end of each week, reliability is assessed by measuring the number of assignments completed relative to the number of assignments planned. For tasks that are not accomplished, analyzing the reasons for plan failure and acting on these reasons is used as a basis for learning and continuous improvement (Ballard 2000a, Ballard et al. (1999a), Ballard et al. (1999b), Ballard and Hamzeh 2007).

Weekly work planning involves: (1) advancing tasks that are well defined, constraint-free, in proper sequence, well sized (in terms of load and capacity), (2) performing collaborative weekly work planning to remove constraints for constrained tasks, (3) exercising reliable promising, and (4) learning from plan failures (Ballard 2000a).

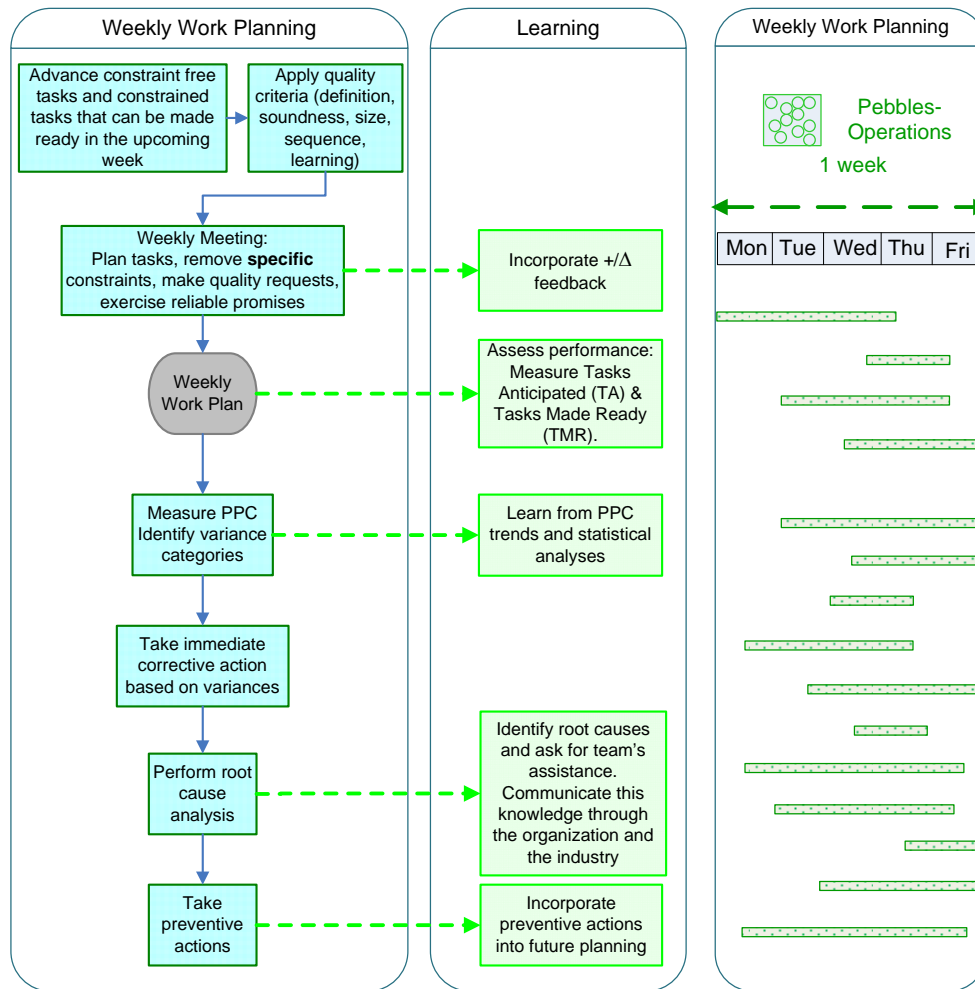

Figure 5.16: The weekly work planning process in the LPS

As Figure 5.16 shows, weekly work planning starts by advancing both tasks that are ready (constraint-free) and tasks that can be made ready during the course of the week (note that predecessors may have to be completed in the plan period, or else slow the pace of work). Capacity permitting, constraint-free critical tasks are given the first priority followed by critical tasks that are constrained but can be made ready during the week. Critical tasks that cannot be made ready are screened out of weekly work plans to shield production from executing tasks that are not ready. These tasks will be evaluated in the upcoming weeks and are given priority in removing their constraints. At this stage non critical tasks that are not ready are also screened out while constraint-free critical

tasks are incorporated on the fall-back / follow-on list to be executed when having extra capacity.

It is desirable to advance to the weekly work plan only tasks that make quality assignments. Quality assignments are measured against five main quality criteria: (1) definition: a task should have a clear scope and desired outcomes, (2) soundness: planned tasks should be constraint-free or can be made constraint-free during the plan period, (3) sequence: arrange tasks in the proper sequence and avoid out-of-sequence work, (4) size: match load and capacity (e.g., match the workload placed on individuals, sub-teams, or work groups with their actual capacity), and (5) learning: use root cause analysis to continuously improve the quality of assignments (make use of the plan-do-check-act (PDCA) cycle)(Ballard 2000a).

Next week's work plan is discussed, coordinated and finalized during a collaborative weekly work plan meeting involving project stakeholders. This meeting enables last planners, team leaders responsible for production teams, to discuss constrained tasks, make requests to remove constraints, and make activities ready by removing constraints. Last planners make quality requests to remove constraints and quality commitments to next week's work tasks.

A quality request/commitment is made when a last planner: (1) makes a clear request with identifiable outcomes, (2) uses a language that signifies an action and an outcome e.g., "Provide a list of equipment to be used in room 405" instead of "Define equipment to be used in room 405", (3) communicates conditions of satisfaction required to the performer, and (4) secures a commitment from the performer.

#### *5.4.4.1 Reliable Promising*

PPC is a metric used to measure the reliability of the weekly work planning process and the process of making reliable promises. Reliable promising is the process of requesting, clarifying / negotiating, making commitments, and executing commitments. Commitments start by a request from a last planner. The request is analyzed leading to negotiations and clarifications. At the end a commitment is either made or declined. The ability to say ‘no’ to certain requests is at the core of making reliable promises. If a commitment is made and the task accomplished, the ‘making reliable promises’ process ends by declaring completion and meeting the conditions of satisfaction of the request made in the first step (Flores 1982, Ballard et al. (1999a), Ballard et al. (1999b), Macomber and Howell 2003, Macomber 2003, Ballard and Hamzeh 2007).

Reliable promising requires a clear communication of the conditions of satisfaction between the performer and the customer. The performer has to apply quality criteria to promised tasks (definition, soundness, size, sequence, and learning), be sincere when the commitment is made, and accept consequences for breaking promises or commitments (i.e., accepting the responsibility to participate in learning from failures and preventing future repetitions).

#### *5.4.4.2 Learning*

As Figure 4.16 conveys, learning takes place during various steps of the process: (1) attending collaborative meetings, (2) analyzing performance metrics (i.e., PPC, TA and TMR), (3) monitoring trends in weekly work planning, (4) identifying root causes for plan failures, and (5) incorporating actions to prevent the repetition of plan failures.

Learning and continuous improvement can be captured during collaborative meeting by using the ‘+/ $\Delta$ ’ method where last planners share with the team what steps they consider add value to the process (+) and what steps need to be improved ( $\Delta$ ). ‘+/ $\Delta$ ’ sessions can be very helpful in uncovering deficiencies, surfacing hidden issues, and generating improvement ideas.

Monitoring and analyzing performance metrics such as PPC, TA, and TMR can provide important insights into the team’s performance in terms of communication, coordination, collaboration, and commitments. Monitoring trends in weekly work plans such as percentage of repeated tasks, percentage of work executed but not planned, and number of constraints, can indicate areas that need further improvement.

While PPC reports the team’s performance and plan failures it does not necessarily give indications to actions that the team needs to take to prevent the recurrence of failures. To uncover these preventive actions root cause analysis is used.

The following is an example of an exercise performing root cause analysis on a construction project. The process starts by monitoring PPC and recording variances from planned work. Figure 5.17 shows a weekly work plan with progress status for completed and non completed tasks in addition to variance categories explaining the apparent reasons for failure to execute the non completed tasks.

Project Name																	
Company 1																	
SCHEDULE ID #	REPEAT	ASSIGNMENT DESCRIPTION Criteria for release of assignments Defined - Sound - Proper Sequence - Right Size - Able to Learn	RESPONSIBLE PARTY	Comments	Critical Path Item	CATEGORIES OF VARIANCE							TOTAL ACTIVITIES	45			
						1	2	3	4	5	6	7	8	9	10	11	12
						Contracts/CO's	Cond of acceptance		PERCENT		78%						
						Prior work comp - others	Schedule/sequence		PLANNED COMPLETE		78%						
						Prior work comp - self	Incorrect time estimate										
						Info/data availability	Off project demands										
						Design Change / RFI	Weather										
						Staff availability	OSH/PD Inspect/Approvl										
						Mtgs/supplies availability	CPMC Decisions										
						CPMC Protocol	Unforeseen Conditions										
						STARTING ON	29-Oct-07		PPC ANALYSIS								
						Mon	Tue	Wed	Thu	Fri	Sat	DONE?		REASONS FOR VARIANCE			
						29-Oct	30-Oct	31-Oct	1-Nov	2-Nov	3-Nov	YES	NO / CATEGORY				
<b>MEP UPGRADES</b>																	
<b>General Contractor</b>																	
		Continue coordination of lobby access	TG/BL	start in account revenue	Y	x	x	x	x	x		x					
510		RLH lobby sprinklers install over Duct	TG/PM		Y	x	x	x	x	x			14				
343		Support Lawson continuing on roof relocate vents	TG/PM		N	x	x	x	x			x					
		Safe off shafts temporarily	TG/MD		Y	x	x	x	x	x		x					
		Improve ILSM	TG/PM		N	x	x	x	x	x		x					
		set up crane pick for Nov 6th	TG		N			x	x	x		x					
526		Coordinate Owner for Bluewater out of sequence	TG/BK		Y	x	x	x	x	x		x					
		Coordinate installation of new pad on D level for	TG/N		N	x	x	x	x	x		x					
<b>Mechanical Subcontractor</b>																	
		install balancing damper for rebalancing hospital	jm		Y	x	x	x	x	x		x					
		installation of roof CHW & HHW piping	JH	connecting to CHW POC	N	x	x	x	x	x		x					
		installation of seismic supports	JH	pipe guides/anchors	N	x	x	x	x				2				
		OR 5 Med Gas	JH	in wall piping	N	x	x	x	x				8				
<b>Electrical Subcontractor</b>																	
		Branch conduit for CHWP-20A, B D-level	Chris		Y	x	x	x				x					
		Branch conduit for EF-3	Chris		Y	x	x	x	x	x		x					
		Branch conduit for HRP-1, 2	Chris		Y	x	x	x	x	x		x					
		Branch conduit for fire alarm roof	Chris		Y					x		x					
		Work Plan for conduit entrance into EE1, EE2	Paul		Y				x				12				
		Determine course of action for installing breaker for EE1A, EE2B	Paul		Y		x	x				x					
		Draft work plan for EE1A breaker installation	Paul		Y								15				
<b>Dry Wall Subcontractor</b>																	
652		finish tape @ lid treat. Rm. for EE1A (A to lobby)	ek		N	x	x	x	x	x		x					
691	2	finish the framing on 2nd once FEC is decided	ek		Y	x	x	x	x	x		x	4				
	1	hang/ tape wall for EE1A (lobby to 1st)	ek		N	x	x	x				x					
	1	fire proofing (Lobby-1st)	ek		N	x	x	x	x	x		x					
		hang/tape wall b level it CO 26	ek		N	x	x	x	x	x		x					
		OR 5/ ceiling and walls	ek		N	x	x	x	x	x		x					
		misc framing for REI/// lobby	ek		N	x						x					
<b>Architect</b>																	
222		CO #52 Lobby Level Clq at large duct further	HF/P		Y	x		x	x			x					
		CO #47 Fire Sprinkler Revs CO's 8, 35-Triage	RLH/P		N		x					x					
229		CO #53 Security Office Ceiling further develop	HF/P		N	x		x	x			x					
<b>PHARMACY ANNEX</b>																	
<b>General Contractor</b>																	
		schedule b/w for demo	hcl	of flooring and plaster	Y	x	x					x					
		go get barn door from mock-up	hcl	to confirm lay-outs	N		x					x					
		lay-out cores for sink and toilet	hcl/s	for B-level P.O.C locations	N	x	x	x	x	x			10	will have to do after containment			

Figure 5.17: Sample of root cause analysis using the weekly work plan.



As per Figure 5.17, the team at this project has distinguished 16 categories of plan variance: contracts / change orders, non completion of previous work by others, non completion of previous work by own crews, missing information / data, design changes / requests for information, unavailability of staff or manpower, unavailability of materials or instruments of labor, owner's protocol, mismatch in conditions of acceptance, schedule / sequence failure, incorrect time estimate, off project demands, weather conditions, inspection and approval by regulatory authority, owner's decisions, and unforeseen conditions.

However, categories of variance discussed above signify only the apparent reasons for plan variance or failure. To understand the root causes behind plan failures the 'five why's' method is used. It involves asking "why" many times in succession until a root cause(s) is found where an action can be taken to prevent the failure from happening again (Ballard et al. (1999a) and Ballard et al. (1999b)).

Root cause analysis should be accompanied by corrective and preventive actions. The corrective action entails devising a quick recovery plan to mitigate the failure or variance. The preventive action which comes after performing root cause analysis should be incorporated into "lessons learned" to make sure the same type of failure does not recur.

Figure 5.18 shows an example 'root cause analysis' process. The exercise investigates failure to perform the task 'laying out cores for sink and toilet' shown on the weekly work plan presented in Figure 5.17. While the apparent reason for failure to complete this task was attributed to 'schedule / sequence' this gives no indication to what

corrective or preventive actions should be used to mitigate the failure and prevent its recurrence.

To uncover the root cause(s), the ‘five why’s’ method is used and documented graphically in Figure 4.18. Asking the question “Why did the sequence / schedule variance occur?” uncovers area abatement as a prerequisite work required to take place prior to commencing lay out. Abatement here refers to removing lead paint from room walls and eradicating asbestos found mainly in fireproofing for room walls. Posing the question “Why was abatement not completed?” directs us into looking at the work of the subcontractor responsible for this activity. Apparently the work falls outside the quantity scope of the subcontractor who was expecting owner’s authorization prior to starting abatement.

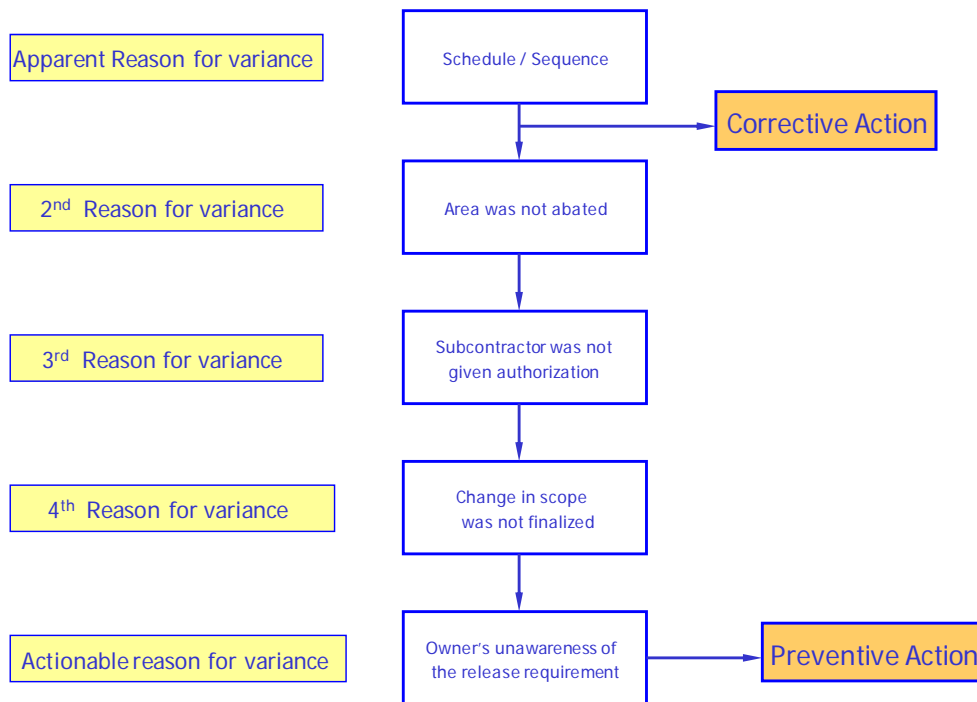

Figure 5.18: An Example exercise for root cause analysis

Again asking “Why didn’t the subcontractor receive authorization?” exposes the process of releasing a change order covering the abatement works. The change order was not finalized at the time the subcontractor needed it. Once more asking “Why wasn’t the change order finalized” reveals the owner’s unawareness of the importance of this release especially that the release does not show as a constraint in schedule. A corrective and a preventive action can be taken at this level.

A quick corrective action can be taken to better implement constraint analysis identifying constraints and making the task ready for execution. The preventive action proposed here is to involve the owner in collaborative meetings and prepare a list of weekly releases required from the owner. This will help the owner remove constraints on time for tasks to take place and prioritize the release of information, directives, decisions, or instructions.

Root cause analysis is one process node in the built-in quality cycle of ‘Detect- Correct- Analyze to root causes- Prevent’ summarized in Figure 5.19 (Ballard 2007). The built-in quality cycle starts by detecting a failure or defect at a work station. In our example reasons for plan variance are used to detect a planning failure for an executed weekly work plan. The second step ‘correct’ involves stopping the line and taking a quick action to correct the failure or defect. Root cause analysis is needed to uncover the root cause(s) followed by devising a preventive action to avoid the recurrence of the same failure in the future. The learning achieved in the repetitive application of this process improves the quality of future planning.

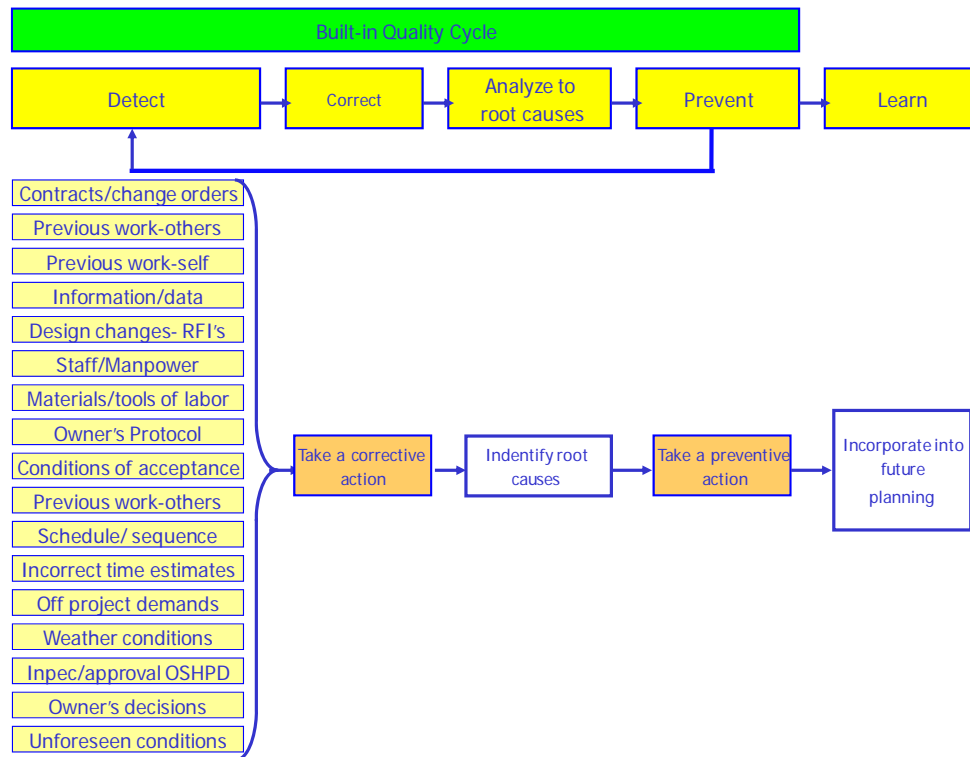

Figure 5.19: Example process for learning from plan failures employing built-in quality

## 5.5 Conclusions

This chapter presents an update of the LPS originally developed by Ballard and Howell. It introduces guidelines for lookahead planning and presents operational steps for implementing the LPS starting from project goals and ending in production plans. The LPS is continuously evolving to incorporate industry challenges and industry experience. While chapter three presents a case study of best industry practices, chapter four suggests an implementation model for the LPS.

Applying the LPS on a project is a lengthy process and requires strong commitment from the owner, top management, and all others involved. The method presented in this chapter is a suggested method that should be tailored to project circumstances and conditions. It is recommended to customize the LPS implementation

to the project by: (1) designating a kick-off team to launch LPS implementation, (2) developing and implementing a training program, (3) providing a positive experience during initial implementation, (4) involving last planners from all project parties, (5) performing regular training classes as users become more advanced, (6) meeting regularly to evaluate the process and compare status to target goals, (7) introducing adjustments and improvements.

The LPS is not only a system for production planning and control but also an enabler for social exchange on construction projects. It institutionalizes coordination and communication by incorporating them into everyday activities and into a managerial structure for project planning and control, team building, and continuous improvement.

The LPS challenges the old practices of developing schedules and pushing them from top management down to frontline people to execute. It advocates collaborative planning, performing collaborative constraint analysis, and learning from plan failures. This LPS update recognizes deficiencies in current practices related to the gap between long-term planning expressed in master and phase schedules and short-term planning expressed in weekly work plans.

When this gap widens, PPC becomes loosely linked to project progress. In other words, weekly work plan performance fails to express project performance. Accordingly, last planners become more reactive and the planning system loses its ability to develop foresight. However, the guidelines proposed in this chapter are expected to improve the performance of the lookahead process by increasing the linkage between the short-term plans and long term plans. Measuring TA and TMR is expected to gauge the performance of the lookahead process and enable statistical analysis of the impact of TA and TMR on

PPC. This subject demands further research to study the nature of the relationship between performance of lookahead planning and weekly work planning. Chapter 6 presents a first step of such study to address this issue by presenting a computer-based model of the process and results of process analysis.

#### References

- Ballard, G. (1997). "Lookahead Planning: The Missing Link in Production Control", *Proceedings of the 5th Annual Conference of the International Group for Lean Construction, IGLC 5*, July, Gold Coast, Australia, pp. 13-26.
- Ballard, G. (1999). "Work structuring." *White Paper-5, Lean Construction Institute*, Ketchum, Id.
- Ballard, G. (2000a). *The Last Planner System of Production Control*. Ph.D. Diss., Faculty of Engineering, School of Civil Engineering, the University of Birmingham, UK, 192 pp.
- Ballard, G. (2006). "Rethinking Project Definition in Terms of Target Costing," *Proceedings of the 14th annual conference of the International Group for Lean Construction*, July, pp. 77-89.
- Ballard, G., (2007). "Built-in Quality Workshop", *Training Workshop – Project Production Systems Laboratory (P<sup>2</sup>SL)*, University of California, Berkeley, (October 8th).
- Ballard, G., (2008). "The Last Planner System of Production Control", *Training Workshop – Cathedral Hill Hospital Project*, San Francisco, California, (August 26th).
- Ballard, G., Hammond, J., and Nickerson, R. (2009). "Production Control Principles", *Proc. 17<sup>th</sup> Annual Conf. Intl. Group for Lean Construction*, Taipei, Taiwan.
- Ballard, G., and Hamzeh, F.R. (2007). "The Last Planner Production Workbook- Improving Reliability in Planning and Workflow", 2<sup>nd</sup> Edition, Lean Construction Institute, California, USA, 81 pp.
- Ballard, G., and Howell (1994). "Implementing Lean Construction: Stabilizing Workflow", *Proceedings of the 2nd Annual Conference of the International Group*

- for Lean Construction, IGLC 2*, Santiago, Chile. In: *Lean construction (1997)*, edited by Luis F. Alarcón C. A A Balkema, Rotterdam.
- Ballard, G., Howell, G., Tommelein, I.D. and Zabelle, T. (1999a). “The Last Planner - Improving Reliability in Planning and Workflow”, T4 Work Book, *Lean Construction Institute*, San Francisco, California, USA, 61 pp.
- Ballard, G., Howell, G., Tommelein, I.D. and Zabelle, T. (1999b). “Lookahead Planning - Streamlining Workflow that Supports the Last Planner”, T5 Work Book, *Lean Construction Institute*, San Francisco, California, USA, pp. 64.
- Ballard, G., Koskela, L., Howell, G., and Zabelle, T. (2001). “Production system design: Work structuring revisited.” *White Paper-11*, Lean Construction Institute, Ketchum, ID.
- Ballard, G., Tommelein, I. D., Koskela, L., and Howell, G. (2003). *Lean Construction Tools and Technique*. Chapter 15 in *Design and Construction: Building in Value*, Butterworth Heinemann, pp. 227-255.
- Best, R., and de Valence, G. (2002). *Design and Construction: Building in Value*, Butterworth-Heinemann, 504 pp.
- Flores, F. (1982). *Management and Communication in the Office of the Future*, PhD Dissertation, University of California at Berkeley.
- Gonzalez, V., Alarcon, L.F., and Mundaca, F. (2008). “Investigating the relationship between planning reliability and project performance”, *Production Planning & Control*, Vol. 19, No.5, July, pp. 461-474.
- Hopp, W.J., and Spearman, M.L. (1996). *Factory Physics*, 1<sup>st</sup> Ed., Irwin, Chicago, 668 pp.
- Hopp, W.J., and Spearman, M.L. (2008). *Factory Physics*, 3<sup>rd</sup> Ed., Irwin/ McGraw-Hill, Boston, 720 pp.
- Howell, G., Laufer, A., and Ballard, G. (1993). “Interaction between subcycles: One key to improved methods.” *J. Constr. Eng. Manage.*, 119(4), 714–728.
- Koskela, L. (2000). *An exploration towards a production theory and its application construction*. PhD Dissertation, University of Technology, Espoo-Finland.
- Liker, J.K. (2004). *The Toyota Way- 14 Management Principles from the World’s Greatest Manufacturer*. McGraw Hill, NY, 330 pp.

- Macomber H. (2004). "Securing Reliable Promises on Projects: A Guide to Developing A New Practice", [http://halmacomber.com/MSRP/reliable\\_promises.pdf](http://halmacomber.com/MSRP/reliable_promises.pdf), last accessed April 2009.
- Macomber, H., and Howell, G. (2003). "Foundations of Lean Construction: Linguistic Action". *Proceedings of the 11<sup>th</sup> annual conference of the International Group for Lean Construction*, Blacksburg, VA.
- Senior, B.A. (2007). "Implications of Action Theories to Lean Construction Applications", *Proceedings of the 15<sup>th</sup> Annual Conference of the International Group for Lean Construction, IGLC 15*, 18-20 July, East Lansing, Michigan, USA, pp. 407-416.
- Suchman, L.A. (1987). *Plans and Situated Actions: The Problem of Human-Machine Communication*, Cambridge, UK: Cambridge University Press.
- Tommelein, I.D. and Ballard, G. (1997). "Look-ahead Planning: Screening and Pulling." *Technical Report No. 97-9*, Construction Engineering and Management Program, Civil and Environmental Engineering Department, University of California, Berkeley, CA.
- Tsao, C.C.Y., Tommelein, I.D., Swanlund, E., and Howell, G.A. (2004). "Work Structuring to Achieve Integrated Product-Process Design", ASCE, *J. of Constr. Engrg. and Mgmt.*, Nov/Dec, 130 (6) 780-789.



## ***CHAPTER 6 - SIMULATION MODEL FOR LOOKAHEAD***

### ***PLANNING***

This chapter introduces a simulation model for studying and analyzing lookahead planning which is a key process in the Last Planner™ System (LPS) for production control. It is divided into three sections. Section 1 explains the need for simulation and the use of discrete event simulation for predictive purposes. Section 2 introduces a simulation model for lookahead planning including conceptual design, mathematical design, and simulation experiments. Finally, Section 3 presents evaluations of the simulation experiments and recommendations for industry practice.

#### **6.1 Background**

Results from the case studies discussed in chapters 3 and 4 present an incomplete evidence to support the positive impact of lookahead planning on increasing weekly planning reliability measured by PPC and increasing the connectedness between weekly work plans and the master schedule by increasing the selection of tasks critical to project success. To study the impact of specific processes in lookahead planning including making tasks ready, breaking down processes into operations, and anticipating future weekly work-plan tasks, requires a study of multiple what-if scenarios. While performing such a study on a running project is difficult at best, simulation offers an effective inexpensive alternative for experimentation, answering what-if questions, and showing the results of different what-if scenarios (Dooley 2002).

Axelrod (2006) highlights multiple ways to use simulation when studying a system including: prediction of what-if scenario results, diagnosis of performance,

human-skills training, education, entertainment, proof of solutions (e.g., the pipe spool simulation study by Tommelein (1998)), and theory discovery.

There are three main schools of simulation: (1) discrete event simulation which models a system in terms of entities and resources changing at discrete time intervals when certain events are triggered, (2) system dynamics which defines the behavior of a system by identifying key-state variables related to each other by differential equations, and (3) agent-based simulation which involves agents that interact with other agents and resources as per certain schema to maximize their utility functions (Dooley 2002).

Discrete event simulation will be used in this study to experiment with what-if scenarios in lookahead planning and analyze their impact on project performance. This serves as a laboratory for testing the hypothesis mentioned in Chapter 1 “Improving the lookahead planning process improves the performance of weekly work planning, increases PPC, and increases the connectedness between weekly work plans and the master schedule by increasing the selection of tasks critical to project success”. The model also helps make predictions about the performance of lookahead planning and its implications on project performance.

The simulation study includes three main steps: (1) conceptual model design which describes the system to be modeled including variables, resources, and events that trigger changes in the system, (2) mathematical model building into a simulation platform, and (3) experimental design where a set of what-if scenarios are tested and evaluated.

## 6.2 Simulation Model

### 6.2.1 Conceptual Model Design

#### 6.2.1.1 Context within the LPS

The purpose of the model is to study and analyze lookahead planning as an integral process in the LPS. Figure 6.1 shows a general layout of the planning cycle using the LPS. The planning cycle starts with developing a master schedule showing major work phases and milestones. M1, M2, M3 and Mn represent master schedules for weeks 1, 2, 3, and n. In a collaborative planning setting, phase scheduling is used to develop a plan for delivering a milestone or a phase. A six-week lookahead view is later taken from the phase schedule to undergo lookahead planning which involves breaking processes into operations, identifying and removing constraints, and designing operations.

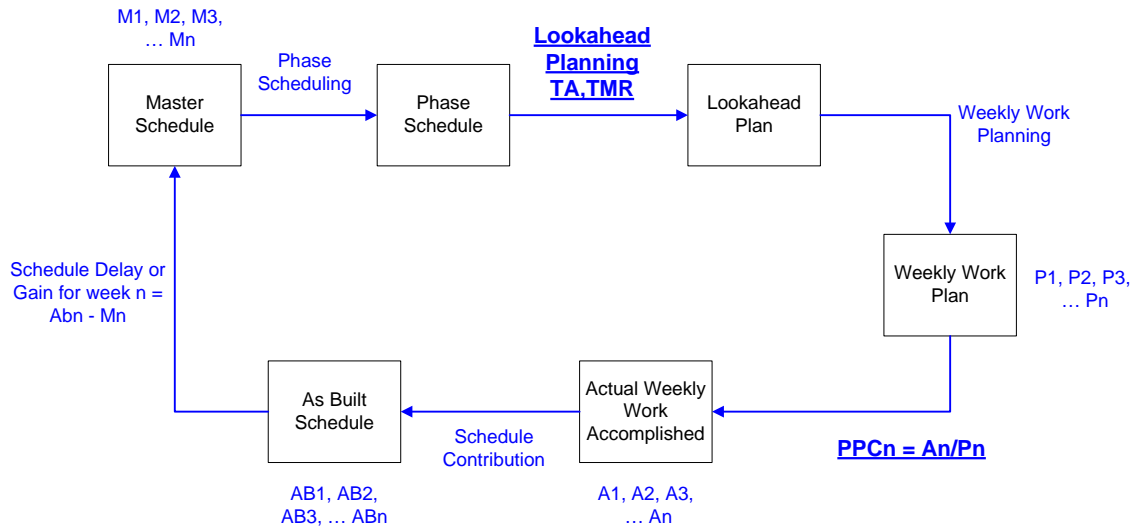

Figure 6.1: The planning cycle using LPS.

Weekly work planning develops weekly work plans from the lookahead plan and involves selecting tasks that meet the quality criteria mentioned in Chapter 5. The resultant weekly work plans are P1, P2, P3, and Pn for weeks 1, 2, 3 and n respectively.

Thus, P1, P2, P3, and Pn are founded and properly linked to M1, M2, M3 and Mn. At the end of the week, the weekly work plan is updated and is called A1, A2, A3 and An. PPC measures the number of tasks completed over the number of tasks planned.

Weekly work completed contributes toward the as-built master schedule, called here schedule contribution, depending on the relevance of the work accomplished to the milestones on the master schedule (e.g., the higher the percentage of out-of-sequence work completed the lower is the schedule contribution). In the same manner AB1, AB2, AB3, and ABn, represent the as-built master schedule for weeks 1, 2, 3, and n. Schedule gain or slippage can be calculated by comparing the as-built schedule to the master schedule (e.g., AB1 to M1).

#### *6.2.1.2 Model Design*

While it is beneficial to study the full planning cycle depicted in Figure 6.1, the simulation model discussed in this chapter is designed to study the lookahead process described in Chapter 5. The model studies the importance of the main three steps in lookahead planning: (1) breaking down processes into the level of operations, (2) identifying and removing constraints to make tasks ready for execution, (3) and designing operations for better task anticipation (the model does not study the impact of operations design on safety, quality, time, and cost).

As highlighted in Figure 6.1, the simulation experiments investigate the impact of improving Tasks Anticipated (TA) and Tasks Made Ready (TMR) on increasing Percent Plan Complete (PPC). The study supports the critical importance of lookahead planning as the link between weekly work plans and the master schedule. Improving lookahead planning is expected to render PPC a better indicator of project progress. When weekly

work planning is not provided tasks from lookahead planning selected and made ready with an eye to their criticality, PPC serves as an indicator of only productivity. However, when weekly work plans are derived from the complete LPS based taking into account task readiness and criticality, PPC can be an indicator of both progress and productivity, an indicator of overall project performance.

The model refers to the process shown in Figure 6.2 where a six- week-lookahead plan is sequentially developed from week 6 to week 1. However, the model introduced in this chapter focuses on processes that take place between week 3 and week 1 ahead of execution.

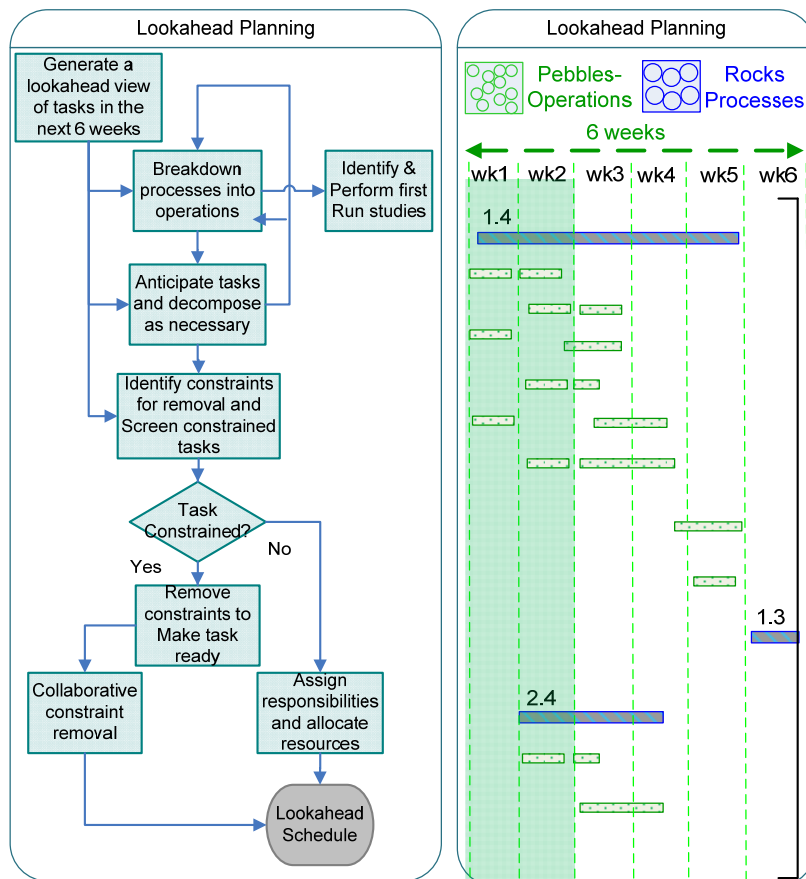

Figure 6.2: The lookahead planning process in the LPS.

The simulation model is designed to study the planning steps taking place in the time frame from three weeks ahead of execution (week 3) until the end of the execution week (week 0) (the model excludes operation design). These steps include breaking down processes into operations, making tasks (processes and operations) ready for execution, shielding and screening, coordination, and tasks execution. Figure 6.3 is a graphical representation of the lookahead planning process from week-3 to week-0, and Figure 6.4 is a graphical user interface for the simulation model studied in this chapter.

The basic modeling elements used in Figure 6.4 are:

(1) “Queues” which are represented in circular shaped Q symbols with the queue name in the center. A queue is used to hold idle resources; in this case it holds tasks.

(2) “Conditional activities (Combi’s)” each represented in a rectangular-shaped element with a wedged corner. A Combi is a named event that can only start when certain resources are available. In this model a Combi represents a planning activity with a given duration that needs resources (i.e., tasks in this simulation model) as inputs (Martinez 1996 and 2001).

The following is a detailed walk-through of the model presented in Figure 6.3 and Figure 6.4 starting at week-3 ahead on execution:

- **StartWithRocks:** the model starts at week 3 ahead of execution with a number of rocks (processes; e.g., build walls) to be broken down into pebbles (operations; e.g., formwork, rebar, concrete). This step embodies breaking down processes into operations which should happen by 3 weeks ahead of execution by later but can start 4 or 5 weeks ahead of execution.

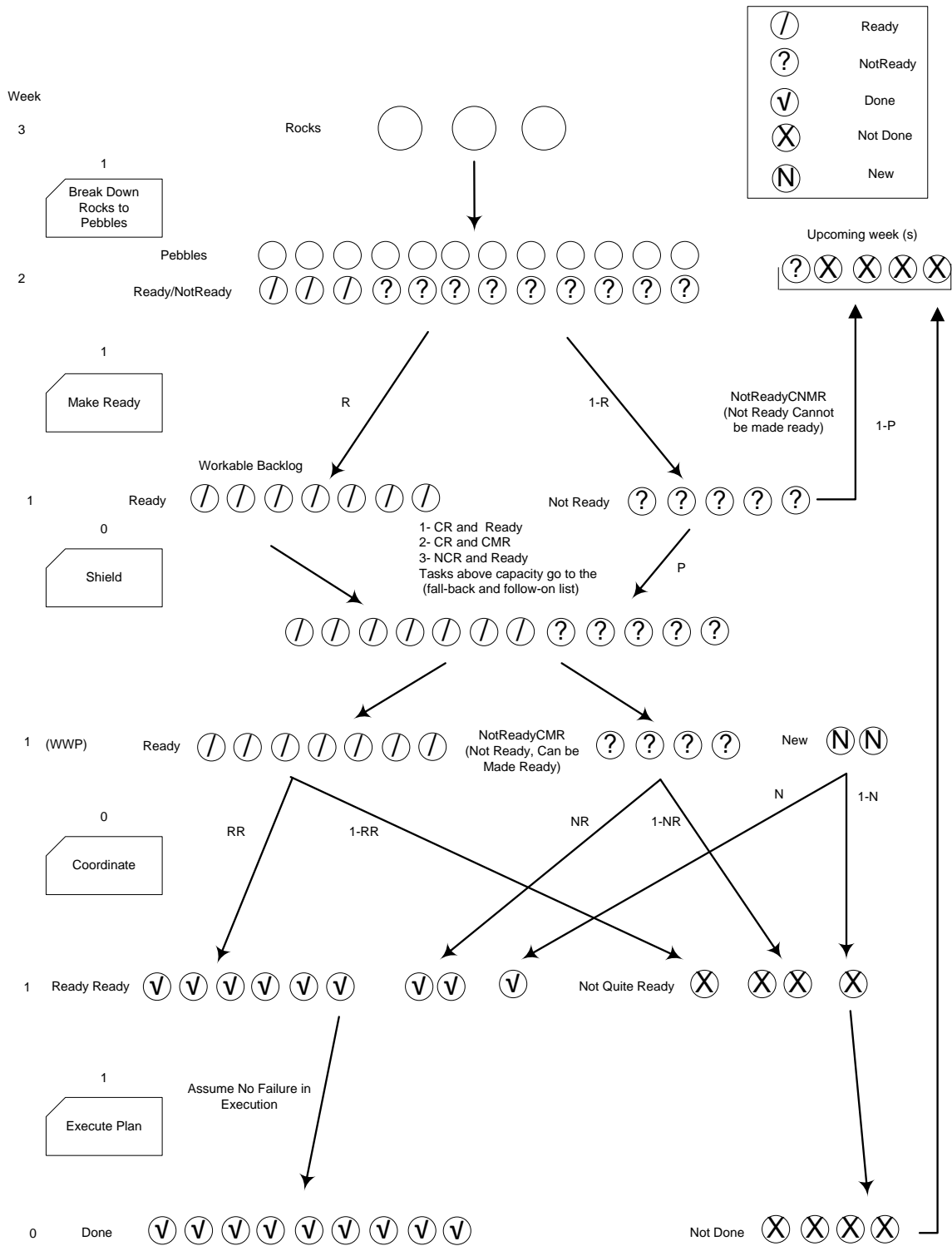

Figure 6.3: Graphical process layout for lookahead planning from three weeks ahead of execution to execution week.

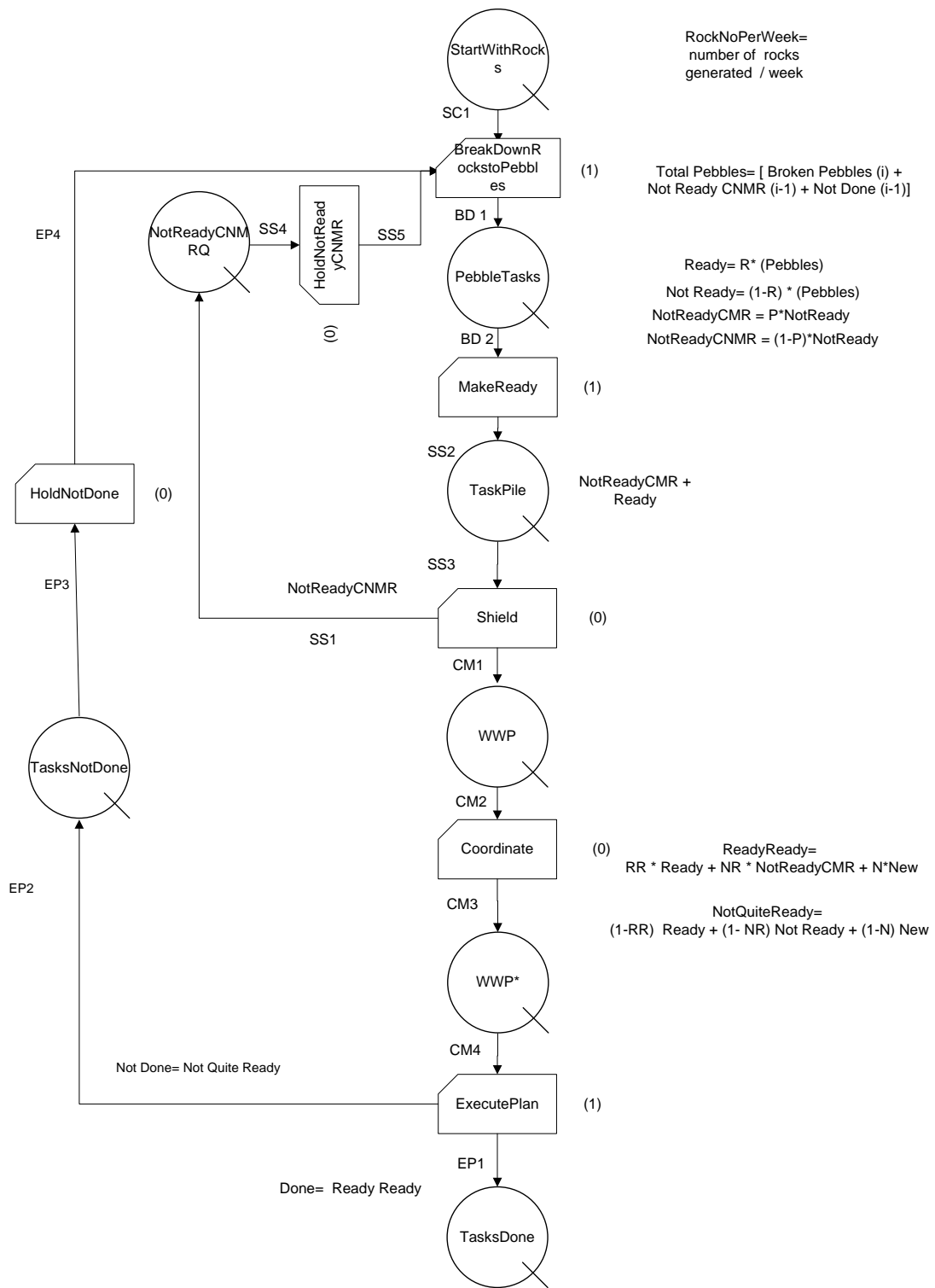

Figure 6.4: Simulation model for lookahead planning



- BreakDownRockstoPebbles: The model assumes that breaking down rocks (processes) to pebbles (operations) happens at this stage by latest. In practice, breakdown can take place earlier than week 3. This step involves breaking down processes into constituent operations as discussed in Chapter 5.
- PebbleTasks: At the beginning of week 2 some of the broken pebbles are constraint-free and thus ready for execution whereas others remain constrained.
- MakeReady: Making tasks ready involves identifying and removing constraints. This includes making all prerequisites required for task execution available including: previous work, information, human resources, material, equipment, space, and external conditions. Although the model assumes that the majority of constraints are removed between week 2 and week 1, some constraints can be removed earlier and others are removed later on during the execution week. Tasks that are Ready (constraint-free) join the workable backlog (a backlog of workable / constraint-free tasks).
- TaskPile: This queue contains both ready (i.e., constraint-free) and NotReady (i.e., constrained) tasks.
- Shield: The shielding step involves protecting downstream tasks from variability in upstream tasks. At this stage NotReady tasks are examined. If there is a chance for making a task ready during the upcoming week then it is considered a candidate for inclusion in the weekly work plan. Such tasks are called NotReadyCMR which stands for “Not Ready but Can be Made Ready”. If there

is no chance of removing constraints for a NotReady task, then it is considered NotReadyCNMR which stands for “Not Ready and Can Not be Made Ready”. NotReadyCNMR tasks move out from the TaskPile and join the next-week’s set of PebbleTasks where they will undergo the Shield step again. It also involves analyzing tasks and placing them on the Weekly Work Plan (WWP) or on the fall-back / follow-on list. Symbolizing the team’s capacity as a bucket which can only accommodate a certain task load, the processes goes as follows: (1) the first tasks to put in the WWP bucket are those critical and ready, (2) if capacity permits, critical and NotReadyCMR tasks go next, (3) non-critical and ready tasks go last if capacity permits; otherwise they are put on the fall-back / follow-on list, (4) filter out NotReadyCNMR tasks and send them to join next week’s TotalPebbles. Figure 6.5 shows a graphical presentation of the Shield process.

- WWP: This is the weekly work plan including all tasks that need to be executed for the upcoming week.
- Coordinate: This coordination step helps the team remove constraints to make NotReadyCMR tasks ReadyReady (i.e., as all prerequisites are available, completion is assured unless a failure occurs during execution). Moreover, this step helps team members understand the conditions of satisfaction when removing constraints for other team members. This insures that Ready tasks (constraint-free) are ReadyReady (are sound) by diligently attending to the prerequisites required by other team members, and obtaining needed commitments.

- WWP\*: This queue includes ReadyReady tasks and NotQuiteReady tasks. NotQuiteReady are those tasks that the team is not able to make ready during the week and those tasks that are mistakenly considered Ready but turn out to be constrained by factors related to uncertainty.
- ExecutePlan: This step involves task execution during the planned week.
- Done: Tasks that are ReadyReady and successfully executed.
- NotDone: Tasks that are NotQuiteReady or those that could not be successfully completed due to a failure in task execution. NotDone tasks join the next-week's set of PebbleTasks.

The process repeats itself from week to week as shown in Figure 6.5. It is worth mentioning that the total number of pebbles at the PebbleTasks queue is the sum of newly-broken-down tasks, NotReadyCNMR tasks of the last week, and NotDone tasks of the last week.

The simulation model was built in Microsoft Excel and run for 1000 iterations. Figure 6.6 presents a snapshot from the model. The first column from the left shows the lookahead planning steps. The second column shows the parameters, variables, and metrics. The fourth to sixth columns show the results of the first 3 iterations. The third column shows the average results for 1000 iterations. Results from all the iterations are then averaged to neutralize the 'warm-up' effects that occur in the initial iterations. This take place because the model starts with '0' number of tasks that are either NotReadyCNMR or NotDone. However, after several runs this number starts to increase as per the variables and parameters used in an experiment. Experiments are run for 1000 iterations to examine changes with time.

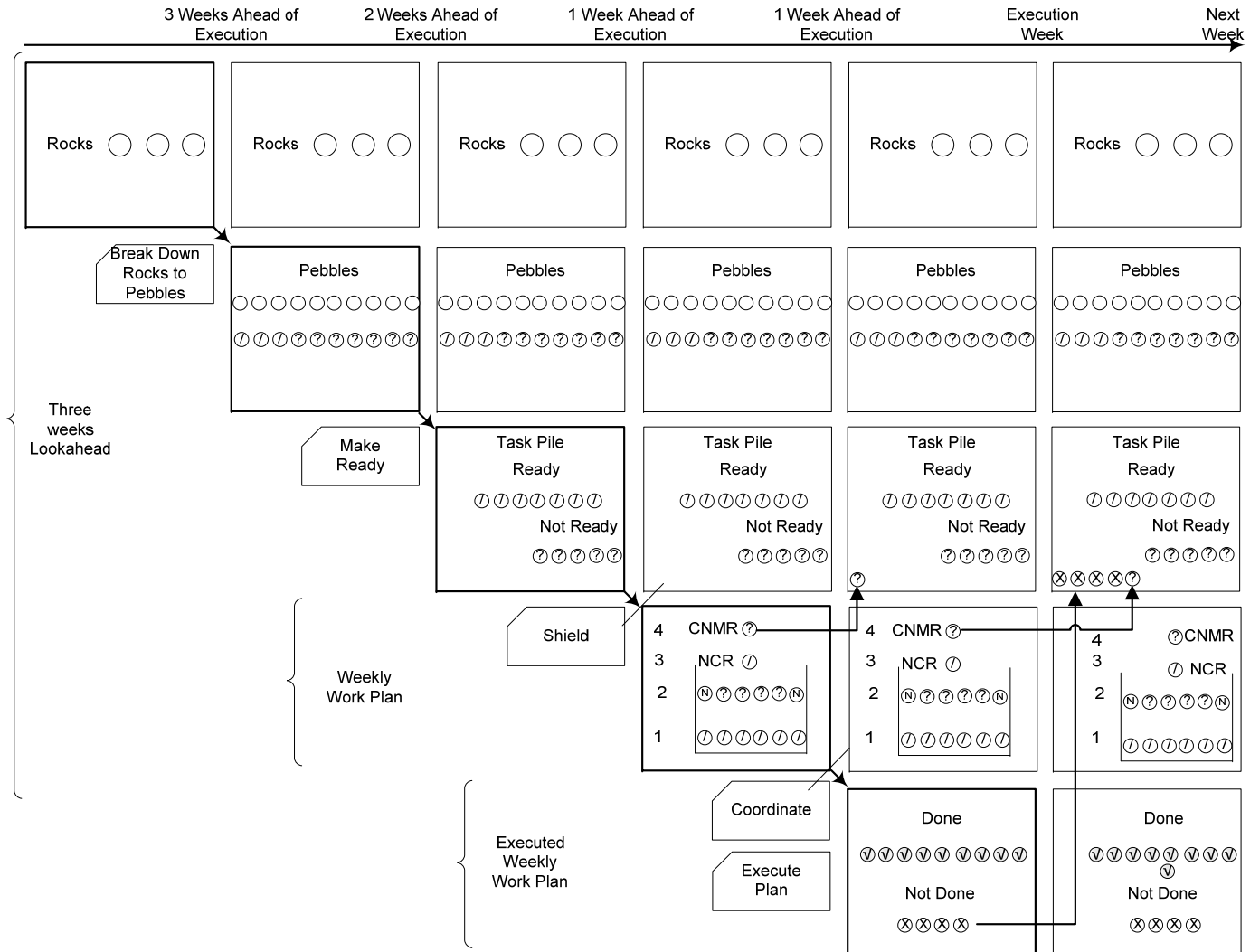

Figure 6.5: The lookahead planning process simulated over a three-week period.

In practice, it is difficult to study 1000 iterations (weeks) and thus the ‘warm-up’ effects are stronger on real projects than what the results show. The simulation is based on a mathematical model expressing the relationship between variables, parameters, and metrics. The model is designed to only predict the trend by which certain variables change with respect to others. The following section introduces and discusses the mathematical notations.

	Simulation Run	Average	1	2	3
BreakDownRocksToPebbles	RockNoPerWeek	40.00	40	40	40
	BreakDownNo	3.00	3	3	3
	Broken Pebbles= RockNoPerWeek x BreakDownNo	120.00	120	120	120
MakeReady	NotReadyCNMR = NotReady- NotReadyCMR	26	0	12	19
	NotDone= NotQuiteReady	118	0	59	88
	TotalPebbles = Broken Pebbles + NotReadyCNMR	264	120	191	227
	R(percentage of Ready Tasks out of TaskPile)	1	0.5	0.5	0.5
Shield	P(percentage of not ready Tasks that can be made)	1	0.8	0.8	0.8
	Ready= Round (Pebbles * R)	132	60	96	114
	NotReady= TotalPebbles-Ready	132	60	95	113
	NotReadyCMR= Round (NotReady * P)	106	48	76	90
Coordinate	NotReadyCNMR = NotReady- NotReadyCMR	26	12	19	23
	New (Not planned)	20	20	20	20
	RR(percentage of Ready Tasks transformed to Ready)	0.50	0.5	0.5	0.5
	NR(percentage of not readyCMR Tasks transformed to Ready)	0.60	0.6	0.6	0.6
ExecutePlan	N (Percentage of new tasks transformed to Ready)	0.50	0.5	0.5	0.5
	ReadyReady= Round( Ready * RR + NotReadyCMR * NR)	140	69	104	121
	NotQuiteReady= Total Pebbles+New - NotReadyCNMR	118	59	88	103
	Done = ReadyReady	139.86	69	104	121
Metrics	NotDone= NotQuiteReady	117.89	59	88	103
	PPC% = Done/ (Done+NotDone)	0.54	0.54	0.54	0.54
	Percentage of not planned to total tasks on WWP	0.08	0.16	0.10	0.09
	TA = (Total Pebbles- NotReadyCNMR) / (Done+NotDone)	0.92	0.84	0.90	0.91
	TMR(2,1) = Ready / Total Pebbles	0.50	0.50	0.50	0.50
	TMR(2,0) = Round( Ready * RR + NotReadyCMR * NR)	0.49	0.49	0.49	0.49
% of repeated Tasks= (NotReadyCNMR+NotQuiteReady) / Total Pebbles	0.54	0.00	0.37	0.47	

Figure 6.6: Snapshot of the model in Excel.

## 6.2.2 *Mathematical Notation*

### 6.2.2.1 Definitions of Variables and Parameters

This is a brief definition of the variables, parameters and metrics used in this simulation:

- RockNoPerWeek = Number of weekly processes (rocks) to be broken down into operations three weeks ahead of execution.
- BreakDownNo = Number of operations (pebbles) broken down from one process (rock).
- Broken Pebbles = RockNoPerWeek x BreakDownNo = Number of new pebbles added each week.
- Total Pebbles = TP = Broken Pebbles + NotReadyCNMR + NotDone = Total number of tasks in the task pile prior to shielding and screening. NotReadyCNMR and NotDone are defined later.
- TP (i) = Number of Total Pebbles during simulation run i.
- TP (i-1) = Number of Total Pebbles during simulation run (i-1) or previous run.
- R = Percentage of Ready Tasks out of Task Pile.
- Ready = R \* Total Pebbles = Number of ready tasks one week before execution. Ready tasks are those made ready by removing constraints and making sure that all prerequisites needed to execute the task are available. Such prerequisites include previous work, information, materials, human resources, space, equipment, and external conditions.

- $\text{NotReady} = (1 - R) * \text{Total Pebbles} = \text{TotalPebbles} - \text{Ready} = \text{Number of tasks that are not ready (i.e., one or more prerequisites are not available) one week ahead of execution.}$
- $P = \text{Percentage of not ready Tasks that can be made ready during the upcoming week.}$
- $\text{NotReadyCMR} = P * \text{NotReady} = \text{Number of NotReady tasks that can be made ready during the upcoming work week.}$
- $\text{NotReadyCNMR} = (1 - P) * \text{NotReady} = \text{NotReady} - \text{NotReadyCMR} = \text{Number of NotReady tasks that cannot be made ready during the upcoming work week}$
- $\text{New} = \text{Number of new tasks added to the weekly work plan that are not planned on the week 2 lookahead plan. These tasks were not envisioned in lookahead planning. Further research is required to study the reasons for having New tasks on weekly work plans.}$
- $\text{RR} = \text{Percentage of Ready tasks transformed to ReadyReady. While Ready tasks are subjectively designated as Ready and thought to be free from constraints at the beginning of the week, some of them are actually not quite ready and cannot to be executed. Some of tasks that are considered ready one week ahead of execution, are found to be not ready during execution week due to lack of understanding the conditions of customer satisfaction, which results from considering a constraint to be removed when it actually still present. On the contrary, ReadyReady tasks are those tasks that are ready, free from constraints, and will get executed (except when an execution failure takes place).}$

- NR = Percentage of NotReadyCNMR tasks transformed to ReadyReady. It is the percentage of NotReady tasks that are made ready during the course of the week.
- N = Percentage of New tasks transformed to ReadyReady. It is the percentage of New tasks that are made ready during the course of the week.
- ReadyReady= Number of tasks that are ReadyReady =  $(RR * Ready + NR * NotReadyCMR + N * New)$ .
- NotQuiteReady = Number of tasks that are not ReadyReady = Total Pebbles + New - NotReadyCNMR - ReadyReady =  $[(1-RR) * Ready + (1-NR) * NotReadyCMR + (1-N) * New]$ . NotQuiteReady are those tasks that the team is not able to make ready during the week and those tasks that are mistakenly considered Ready but turn out to be constrained by factors related to uncertainty.
- EF = Execution Failure = Percentage of ReadyReady tasks that do not get completed because of a failure in the execution of an operation.
- Done =  $(1-EF) * ReadyReady$  = Number of completed tasks at the end of the week.
- NotDone = NotQuiteReady +  $EF * ReadyReady$  = Number of tasks that are not completed tasks at the end of the week.
- NTP = Percentage of New tasks to Total Pebbles of simulation run  $i = New / TP(i)$ .

#### 6.2.2.2 Model Assumptions

The simulation model is built under the following assumptions:



- No breakdown takes place during task execution which means that execution failure = 0. Therefore, all ReadyReady tasks are transformed to Done tasks and all NotQuiteReady tasks are transformed to NotDone tasks by definition.
- No logical dependencies between tasks (i.e., a simplifying assumption that allows disregard of sequence).
- Gross constraints (discussed in Chapter 5) have been resolved three or more weeks ahead of execution. Constraints considered here are only specific constraints.
- Capacity constraints are not considered and all tasks passing the Shield step make it to the WWP. Therefore, no tasks go on the fall-back / follow-on list.
- The model assumes no distinction between critical and non critical tasks.
- Tasks are not competing for resources.
- Tasks are generated perpetually. The simulation experiments run for 1000 simulations or weeks. Section 6.2.1.2 discusses the logic for using 1000 iterations.
- Parameters (e.g., R, RR, etc.) used in each experiment are held constant for 1000 iterations as described in the summary table for each experiment.

Although the model incorporates these simplifying assumptions, it remains fit to serve its purposes: studying PPC trends and the relationship between variables, parameters, and metrics. While the model is not used to predict observable phenomena or express the planning system in its entirety, it can predict the trend by which certain variables change with respect to others without predicting the exact scale of that impact.

### 6.2.2.3 Definitions and Calculation of Metrics

- PPC = Percent Plan Complete= Done / (Done + NotDone)

$$PPC = [Ready * RR + NotReadyCMR * NR + New * N] / [Ready * RR + NotReadyCMR * NR + New * N] + [Ready * (1-RR) + NotReadyCMR *(1- NR) + New *(1- N)] \quad (1)$$

Substituting the values of Ready by [R \* TP(i)] and NotReadyCMR by [TP(i) \* (1-R) \* P] we get the following for PPC:

$$PPC = [TP(i) * R * RR + TP(i) * (1-R)* P * NR + New * N] / [ TP(i) *R * RR + TP(i) *(1-R)* P * NR + New * N] + [TP(i) *R * (1-RR) + TP(i) * (1-R)* P *(1- NR) + New *(1- N)] \quad (2)$$

Taking TP(i) as a common factor we get the following:

$$PPC = TP(i) * [R * RR + (1-R)* P * NR + New / TP(i) * N] / TP(i) * [R * RR + (1-R)* P * NR + New / TP(i) * N + R * (1-RR) + (1-R)* P *(1- NR) + New / TP(i) *(1- N)] \quad (3)$$

Substituting New / TP(i) with NTP and eliminating TP(i) from the numerator and the denominator we get the following:

$$PPC = [R * RR + (1-R)* P * NR + NTP * N] / [R * RR + (1-R)* P * NR + NTP * N] + [R * (1-RR) + (1-R)* P *(1- NR) + NTP *(1- N)] \quad (4)$$

The previous formula will be used to study and simulate the impact of the variables involved on PPC.

- TA = Tasks Anticipated = Percentage of tasks on the weekly work plan that were successfully anticipated on week 2 of the lookahead plan. As per the example

shown in Figure 6.7, out of the 18 tasks on the weekly work plan 14 were anticipated on the week 2 lookahead. Therefore, TA = 14/18 = 78 %. Referring to Figure 6.3, Tasks Anticipated can be calculated in the following manner:

$$= (\text{Total Pebbles} - \text{NotReadyCNMR}) / (\text{Done} + \text{NotDone})$$

$$\text{TA} = [\text{TP}(i) - \text{TP}(i-1) * (1-R) * (1-P)] / [\text{TP}(i) - \text{TP}(i-1) * (1-R) * (1-P) + \text{New}] \quad (5)$$

$$\text{TA} = [\text{TP}(i) (1 - [\text{TP}(i-1) / \text{TP}(i)] * (1-R)*(1-P))] / [\text{TP}(i) (1 - [\text{TP}(i-1)/\text{TP}(i)]* (1-R)*(1-P) + \text{New} / \text{TP}] \quad (6)$$

$$\text{TA} = (1 - [\text{TP}(i-1) / \text{TP}(i)] * (1-R)*(1-P)) / [(1 - [\text{TP}(i-1) / \text{TP}(i)] * (1-R)*(1-P) + \text{NTP}] \quad (7)$$

TMR = Tasks Made Ready = Percentage of tasks on the executed weekly work plan that were successfully anticipated on the week 2 lookahead plan. As per the example shown in Figure 6.7, out of the 20 tasks on the week 2 lookahead plan, 11 tasks on the weekly work plan were (WWP or WK1) executed at the end of the week. Therefore, TMR = 11/20 = 55 %. Referring to Figure 6.3, Tasks Made Ready TMR (2, 0) can be calculated in the following manner:

$$\text{TMR}(2, 0) = (\text{Ready} * \text{RR} + \text{NotReadyCMR} * \text{NR}) / \text{TP}(i) \quad (8)$$

$$\text{TMR}(2, 0) = (\text{TP}(i) * \text{R} * \text{RR} + \text{TP}(i) * (1-R) * \text{P} * \text{NR}) / \text{TP}(i) \quad (9)$$

$$\text{TMR}(2, 0) = \text{R} * \text{RR} + (1-R) * \text{P} * \text{NR} \quad (10)$$

It might be useful to also monitor the percentage of ready tasks relative to total pebbles or what it is called TMR (2, 1). Referring to Figure 6.3, TMR (2, 1) can be calculated in the following manner:

$$\text{TMR}(2, 1) = \text{Ready} / \text{TP}(i) = R * \text{TP}(i) / \text{TP}(i) = R \quad (11)$$

In other words R by definition is TMR (2, 1).

In addition TMR (1,0) can be calculated as follows:

$$\text{TMR}(1, 0) = \text{Done} / (\text{Done} + \text{NotDone}) = \text{PPC} \quad (12)$$

### 6.2.3 *Experimental Simulations*

The experimental simulations are designed to study the impact of various variables including R, RR, P, NR, N, New, TA, and TMR on PPC. The goal is to improve the performance of lookahead planning to increase PPC. Analyzing the model shown in Figure 6.3 suggests three main ways / routes through the lookahead plan to increase PPC.

The first route is through “R and RR”, the second through “(1-R), P, and NR”, and the third through “New and N”. The three routes are shown graphically in Figure 6.8. Accordingly, three main experiments are performed to find out the impact on PPC through each of these routes. The other experiments analyze the impact of TA and TMR on PPC. All simulation experiments are run for 1000 iterations. Each iteration represents a plan week as presented in the weekly planning process shown in Figures 6.3 and 6.5.

#### 6.2.3.1 *R and RR*

Experiment 1 studies the relation between R and RR and their impact on PPC. BreakDownNo was assigned a value of 3 to indicate that process can be broken down to 3 operations on average. RockNoPerWeek was assigned a value of 40 which is arbitrarily chosen to result in a large number of TotalPebbles (120) required to show the impact of small changes in variables and parameters on metrics. The values for the different variables / metrics used in experiment 1 are summarized in Table 6.1.

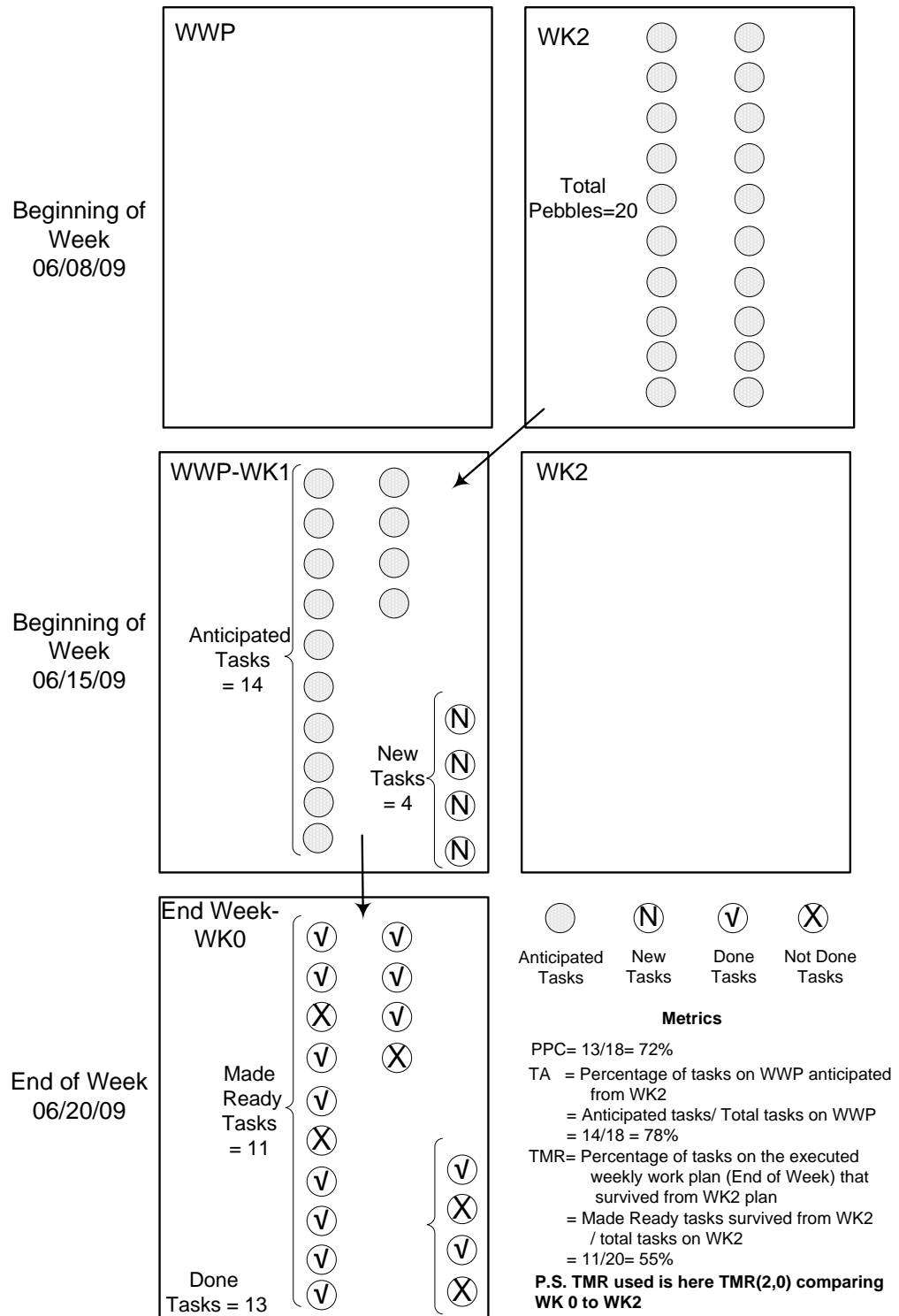

Figure 6.7: Calculating TA and TMR (2, 0).

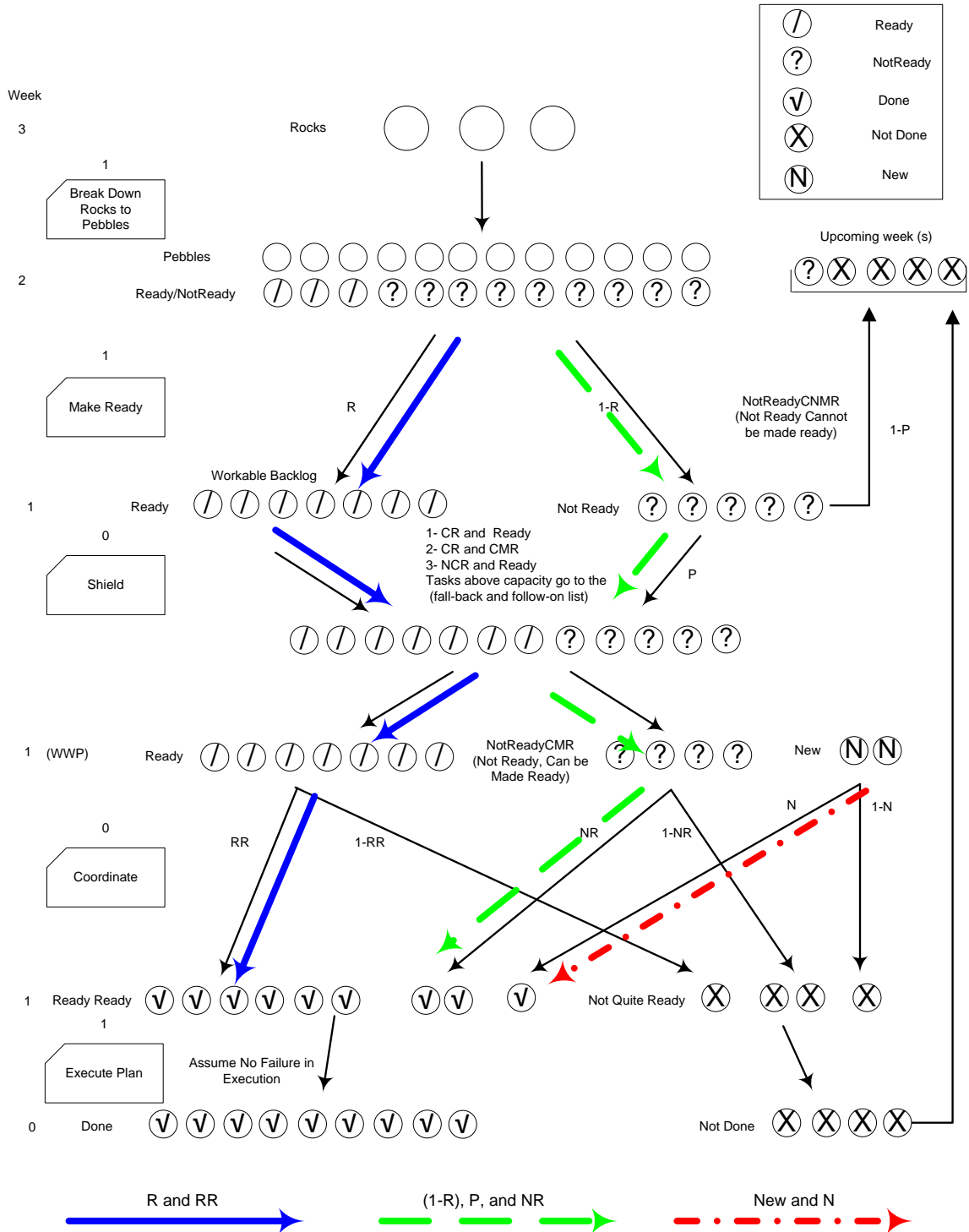

Figure 6.8: The three possible paths to increasing PPC.

Table 6.1: Variables and Parameters for Experiment 1 - Deterministic: R, RR, and PPC.

Parameter / Variable	Value
RockNoPerWeek	40
BreakDownNo	3
R	0 to 1 in 0.1 increments
P	0.8
RR	0, 0.5, 0.6, 0.85, 1
NR	0.6
New	20
N	0.5

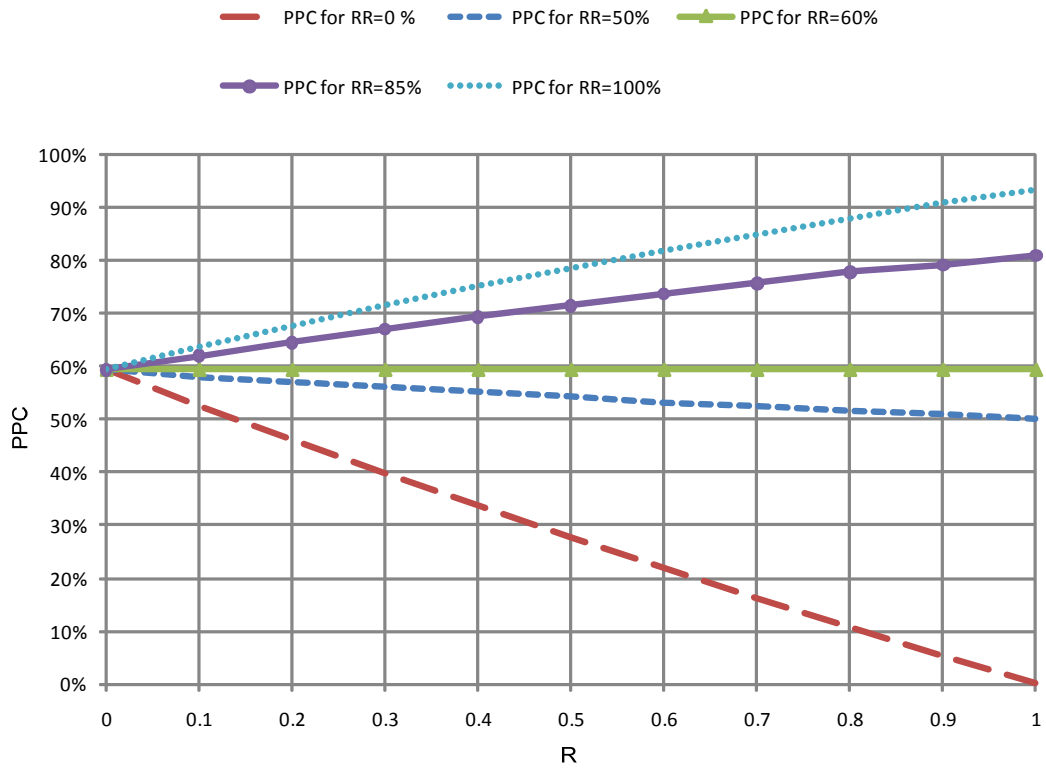

Figure 6.9: Simulation results for Experiment 1 showing the relationship between R, RR, and PPC using deterministic variables.

Figure 6.9 presents results of five simulations using different values of RR (0, 0.5, 0.6, 0.85, and 1). In each simulation, R was varied between 0 to 1 in increments of 0.1.

The results suggest that increasing R on its own does not help increase PPC except for a high value of RR. Otherwise, if RR is low increasing R would actually reduce PPC. In other words, it is not always beneficial to make tasks ready early on when it turns out that only a small percentage of those tasks are actually ReadyReady.

For the model to be able to predict observable phenomena or express the planning system in its entirety stochastic inputs should be used. But since this model is designed to only predict the trend by which certain variables change with respect to others without predicting the exact scale of that impact, stochastic inputs can be avoided. Thus, the experiments will use deterministic variables and focus on the relationship between variables and their impact on PPC.

Analyzing the results shown in Figure 6.9, suggests that R on its own cannot dictate the outcome of PPC. It is strictly coupled with RR. In practice, this means that the perception of Ready tasks evaluated one week before execution might be biased and uncertain. Some of these so called ‘Ready’ tasks will appear constrained at the time they are put into execution. This phenomenon is represented by RR. Accordingly, a low value of RR reduces the chances of task completion and achieving high PPC. A question comes to mind at this stage: what happens to PPC when R is low?

Figure 6.8 indicates three main streams contributing to PPC. One of these streams is through R and RR. When R is low more tasks are channeled through the “(1-R), P, NR” stream and NR becomes an important factor in determining PPC. Thus, it is intriguing to inspect the relationship between R and NR. This is the goal of simulation



experiment 2. Table 6.2 shows the values of variables used in this experiment and Figure 6.10 shows the simulation results.

Table 6.2: Variables and Parameters for Experiment 2 - Deterministic: R, NR and PPC.

Parameter / Variable	Value
RockNoPerWeek	40
BreakDownNo	3
R	0 to 1 in 0.1 increments
P	0.8
RR	0.8
NR	0.5, 0.7, 0.9
New	20
N	0.5

The results shown in Figure 6.10 indicate the importance of NR for low values of R. If R is low, a low number of tasks make it through the “R, RR” stream even when RR is quite high. For a low R, the ideal path for tasks toward completion is through NR. This means that even when early efforts to make tasks ready are not very successful (low R) a high PPC can be achieved when constraint removal efforts during the execution week are successful (high NR). This conclusion is supported by assuming an infinite capacity during the execution week to make task ready and execute them. However, in real practice anticipating tasks early and understanding their constraints gives the execution team lead time to mobilize resources make tasks ready early.

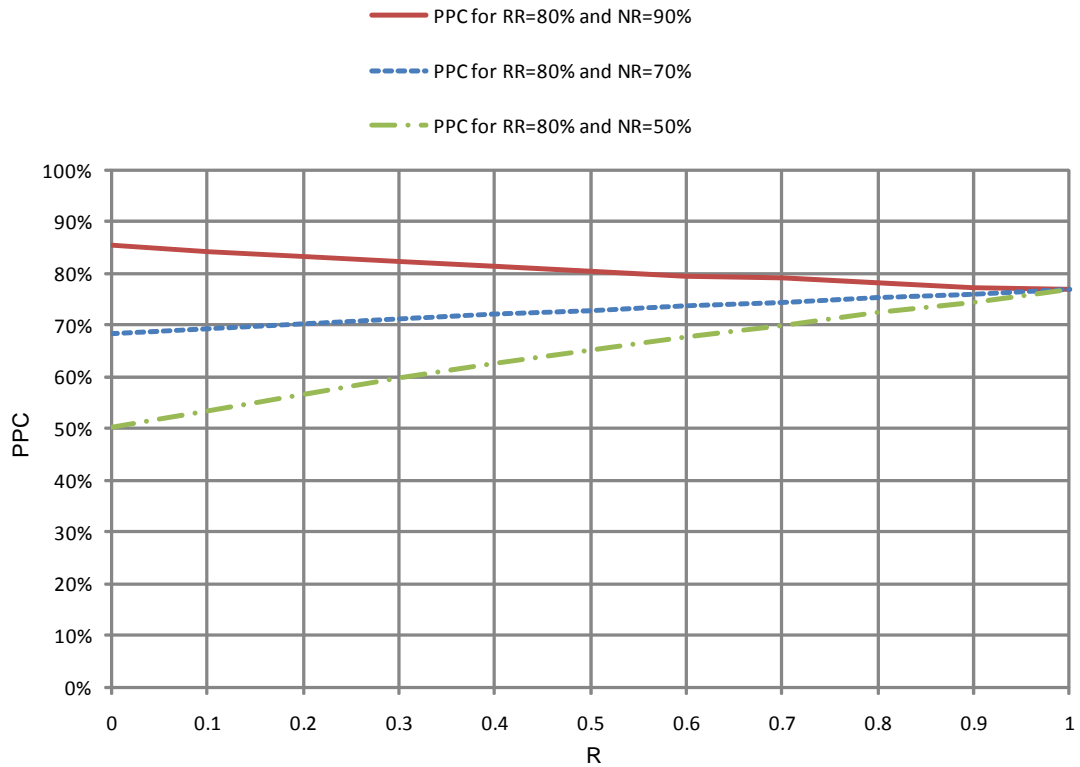

Figure 6.10: Results from Experiment 2 showing the relationship between R, NR, and PPC.

### 6.2.3.2 *P and NR*

Simulation experiment 3 is designed to evaluate the relation between P and NR. For each value of NR (0, 0.6, 0.85, and 1), P is varied between 0 and 1 in increments of 0.1 to study the impact of NR and P on PPC. These values span the sample space between 0 and 1. Table 6.3 shows the values of variables used in this experiment and Figure 6.11 shows the simulation results.

Table 6.3: Variables and Parameters for Experiment 3 - Deterministic: P, NR, and PPC.

Parameter / Variable	Value
RockNoPerWeek	40
BreakDownNo	3
R	0.6
P	0 to 1 in 0.1 increments
RR	0.85
NR	0, 0.6, 0.85, 1
New	20
N	0.5

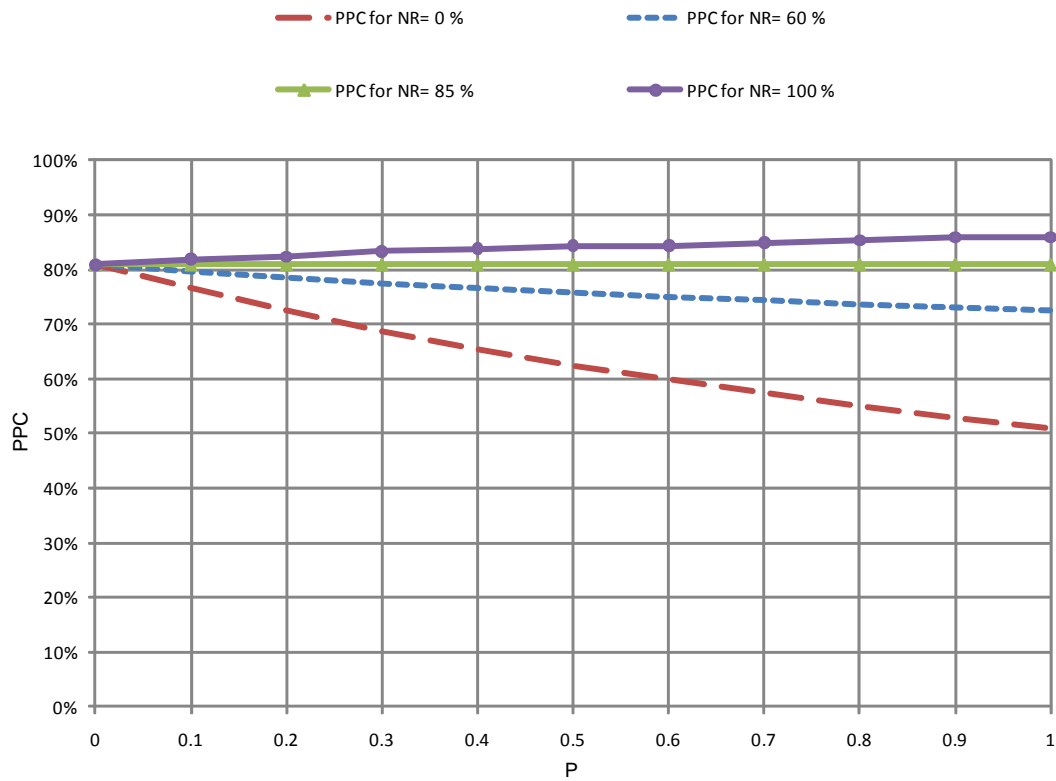

Figure 6.11: Results from Experiment 3 showing the relationship between P, NR, and PPC.

The results shown in Figure 6.11 highlight the importance of NR with respect to P. Although it is desired to have a high number of tasks that can be made ready during the work week out of the NotReady tasks (high P), it is more important to remove constraints and make those tasks ready during the week (high NR). In fact, when NR is low it is useless to increase P as this will not contribute to increasing PPC. An important question to ask is: what is the role of RR in relation to P and NR?

Experiment 4 tries to answer this question by varying P from 0 to 1 in increments of 0.1 for each value of RR (0.75, 0.85, and 0.95) and for a given value of NR (0.85). The values used in this experiment were arbitrarily chosen to show the role of RR in relation to NR even when NR is high (0.85). Table 6.4 shows the values of variables used in this experiment and Figure 6.12 shows the simulation results.

Table 6.4: Variables and Parameters for Experiment 4 - Deterministic: P, NR, RR, and PPC.

Parameter / Variable	Value
RockNoPerWeek	40
BreakDownNo	3
R	0.6
P	0 to 1 in 0.1 increments
RR	0.75, 0.85, 0.95
NR	0.85
New	20
N	0.5

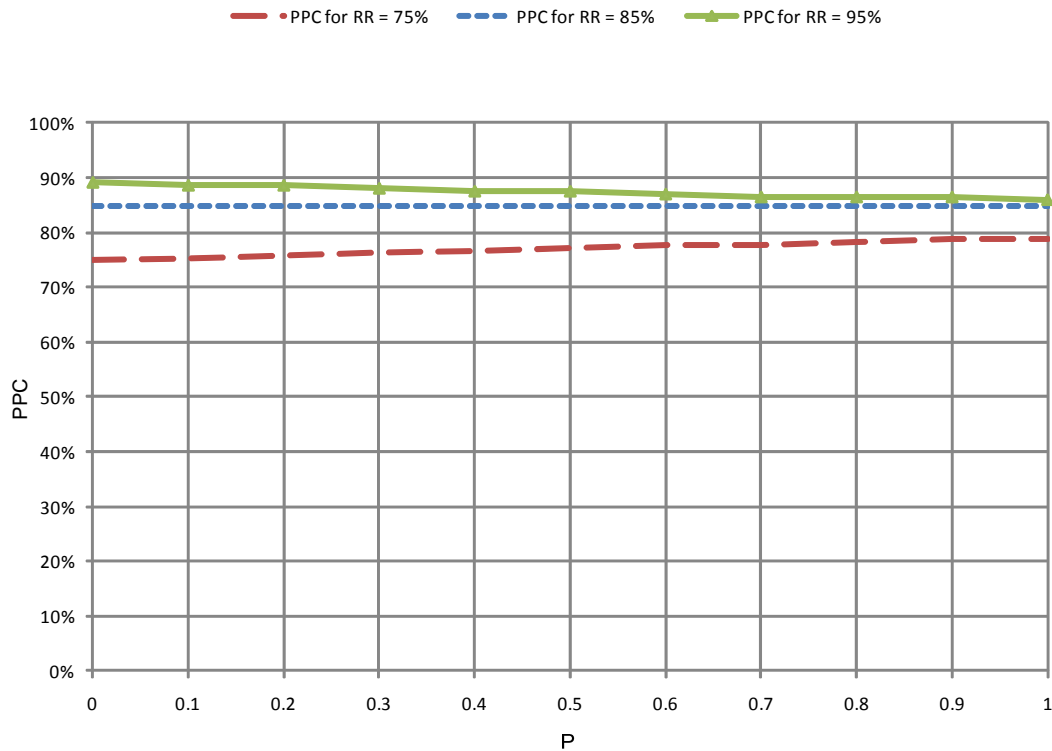

Figure 6.12: Results from Experiment 4 showing the relationship between NTP, N and PPC.

The results summarized in Figure 6.12 show that for a certain value of NR, increasing P beyond a certain threshold does not contribute to PPC especially when RR is high. This result suggests that a certain desired PPC target can be achieved using different combinations of R, P, NR, and RR. Section 6.3 presents a more detailed discussion related to this conclusion.

### 6.2.3.3 *New and N*

The impact of newly added tasks to the weekly work plan is interesting to study. While this research does not study the cause of having these new tasks in practice, future research should address this issue. While the impact of increasing “New” on TA is predictable (the higher New is the lower TA is), its impact on PPC is not intuitively

predicted. Thus, experiment 5 studies the impact of increasing New from 10 to 100 in increments of 10 for several values of N (0.5, 0.7, and 0.9) which are arbitrarily chosen, on PPC. Table 6.5 shows the values of variables used in this experiment and Figure 6.13 shows the simulation results.

Table 6.5: Variables and Parameters for Experiment 5 - Deterministic: New, N and PPC.

Parameter / Variable	Value
RockNoPerWeek	40
BreakDownNo	3
R	0.6
P	0.8
RR	0.85
NR	0.85
New	10 to 100 in increments of 10
N	0.5, 0.7, 0.9

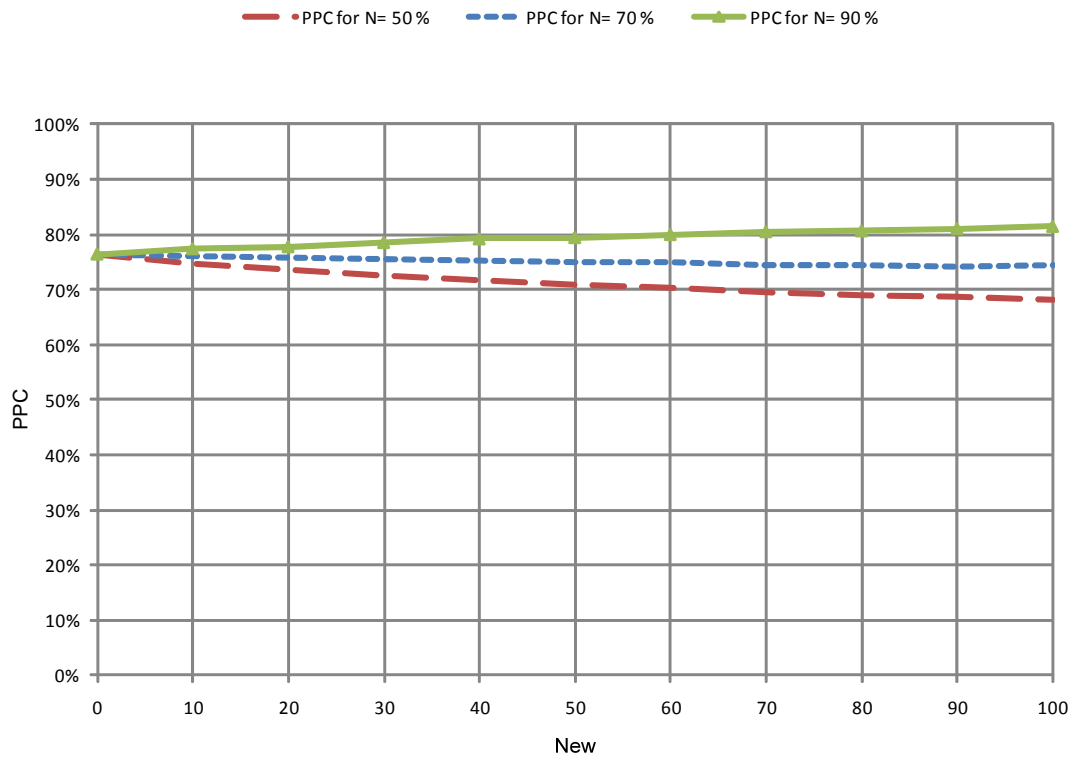

Figure 6.13: Results from Experiment 5 showing the relationship between New, N, and PPC.

The results presented in Figure 6.13, suggest that one way to increase PPC when the number of newly added activities on the weekly work plan is high (high New) is to increase the rate of making the new tasks ready. This suggests not adding new tasks to the weekly work plan unless it is highly certain that these tasks are ready or can be made ready during the upcoming week (high N).

#### 6.2.3.4 TA and PPC

Chapter 5 presents a framework for performing lookahead planning by breaking tasks down, designing operations, anticipating tasks, and making tasks ready. It is expected that increasing TA would result in an increase in PPC. However, this relation is not clear. Thus, experiment 6 studies the impact of increasing TA from 80% to 90% and to 95% for

several values of R (0.1 to 1 in increment of 0.1) and P (0.1 to 1 in increment of 0.1) on PPC. However, to maintain a certain value of TA e.g., 80% the ratio of newly added tasks to the total number of tasks on the weekly work plan needs to be maintained. In this case NTP will be equal to 20%. Table 6.6 shows the values of variables used in this experiment and Figure 6.14 shows the simulation results.

Table 6.6: Variables and Parameters for Experiment 6 - Deterministic: TA, R, P, and PPC.

Parameter / Variable	Value
RockNoPerWeek	40
BreakDownNo	3
R	0.1 to 1 in 0.1 increments
P	0.1 to 1 in 0.1 increments
RR	0.85
NR	0.6
New	Varies to give an NTP of 0.05, 0.1, 0.2
N	0.5



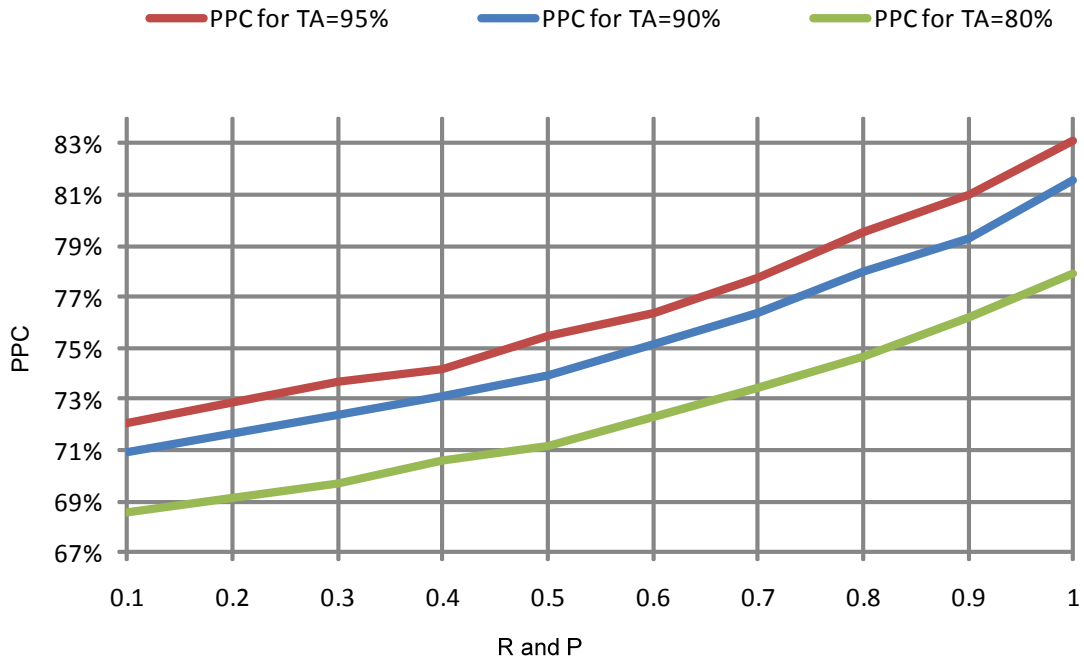

Figure 6.14: Results from Experiment 6 showing the relationship between TA, R, P, and PPC.

The results presented in Figure 6.14 show that increasing TA does contribute to increasing PPC. However, the results also show that increasing TA can only contribute a certain portion towards PPC and other variables including (P and R) need also to be increased to have a larger impact on PPC. However, Figure 6.14 does not show that role of NR and RR. Accordingly, experiment 7 is designed to address this issue.

Experiment 7 studies the impact of increasing TA from 80% to 90% and to 95% for several values of RR (0.1 to 1 in increment of 0.1) and NR (0.1 to 1 in increment of 0.1) on PPC. R and P are held constant in this experiment. The number of newly added tasks to the work plan “New” is varied in each simulation run to achieve the desired values of NTP (0.2, 0.1, and 0.05) and TA (80%, 90%, and 95%). Table 6.7 shows the values of variables used in this experiment and Figure 6.15 shows the simulation results.

Table 6.7: Variables and Parameters for Experiment 7- Deterministic: TA, RR, NR and PPC.

Parameter / Variable	Value
RockNoPerWeek	40
BreakDownNo	3
R	0.6
P	0.8
RR	0.1 to 1 in 0.1 increments
NR	0.1 to 1 in 0.1 increments
New	Varies to give an NTP of 0.05, 0.1, 0.2
N	0.5

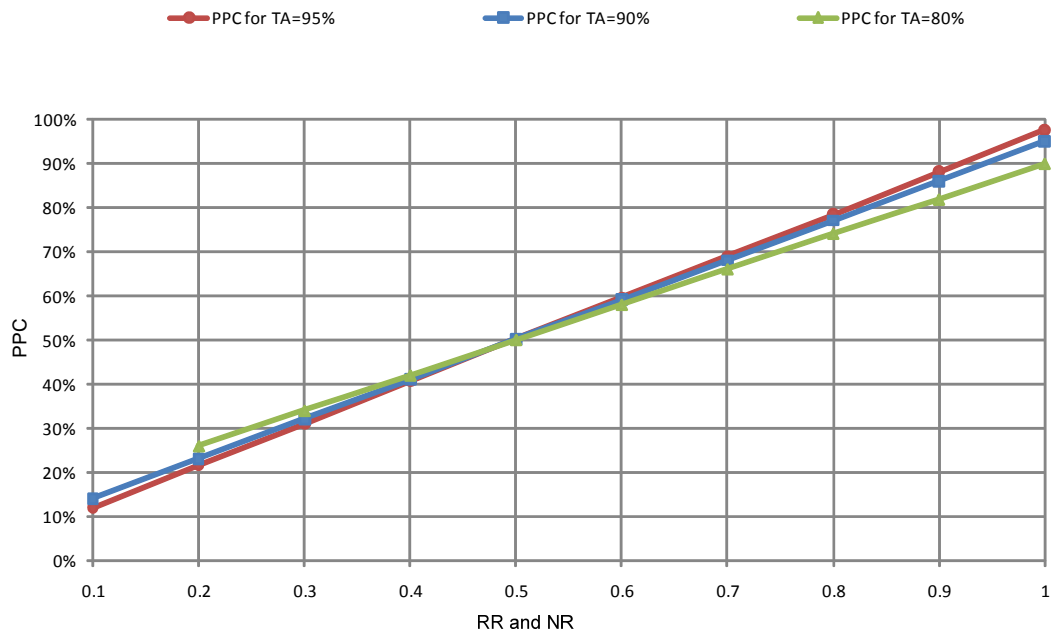

Figure 6.14: Results from Experiment 7 showing the relationship between TA, RR, NR and PPC.

The results presented in Figure 6.15 reinforce the previous observations that increasing TA contributes to increasing PPC. This contribution is marginal unless it is coupled with an increase in RR, NR or both. The results show that increasing TA combined with improving constraint removal during the plan week (i.e., increasing RR and NR) increases PPC considerably. Therefore, increasing TA on its own is futile unless coupled with one of the following alternatives: (1) an increase in R and RR, (2) an increase in P and NR, and (3) an increase in RR and NR with a balancing combination of R and P.

Since  $TMR(2, 0) = R * RR + (1-R) * P * NR$ , all of the above alternatives lead to higher values of TMR. Thus, it is intriguing to find out the influence of TMR on PPC. The next section addresses this issue.

#### 6.2.3.5 TMR and PPC

Experiments 8 and 9 intend to assess the impact of TMR on PPC. While TMR is gradually increased by increasing (R, RR) from (0.5, 0.5) to (0.9, 0.9) and keeping other variables constant in experiment 8, TMR is increased in experiment 9 by increasing (P, NR) from (0.5, 0.5) to (0.9, 0.9) while keeping other values constant. Tables 6.8 and 6.9 show the values of variables used in experiments 8 and 9. Figures 6.16 and 6.17 show the simulation results.

Table 6.8: Variables and Parameters for Experiment 8 - Deterministic: TMR, R, RR and PPC.

Parameter / Variable	Value
RockNoPerWeek	40
BreakDownNo	3
R	0.5, 0.7, 0.9
P	0.8
RR	0.5, 0.7, 0.9
NR	0.6
New	20
N	0.5

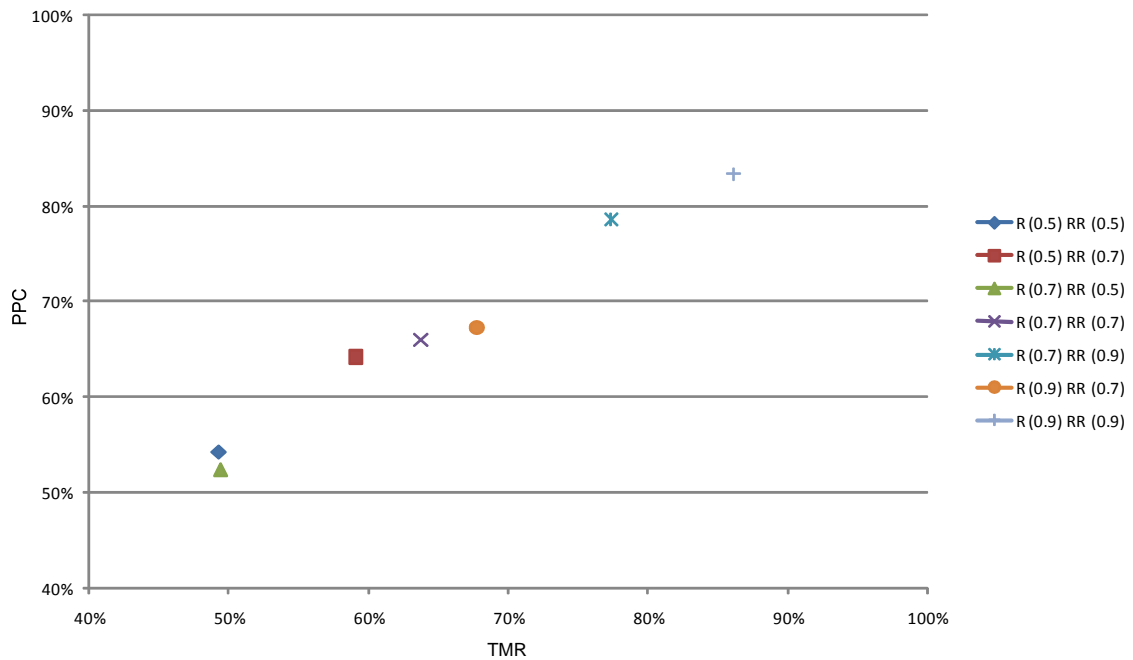

Figure 6.16: Results from Experiment 8 showing the relationship between TMR, R, RR and PPC.

Table 6.9: Variables and Parameters for Experiment 9 - Deterministic: TMR, P, NR and PPC.

Parameter / Variable	Value
RockNoPerWeek	40
BreakDownNo	3
R	0.6
P	0.5, 0.7, 0.9
RR	0.85
NR	0.5, 0.7, 0.9
New	20
N	0.5

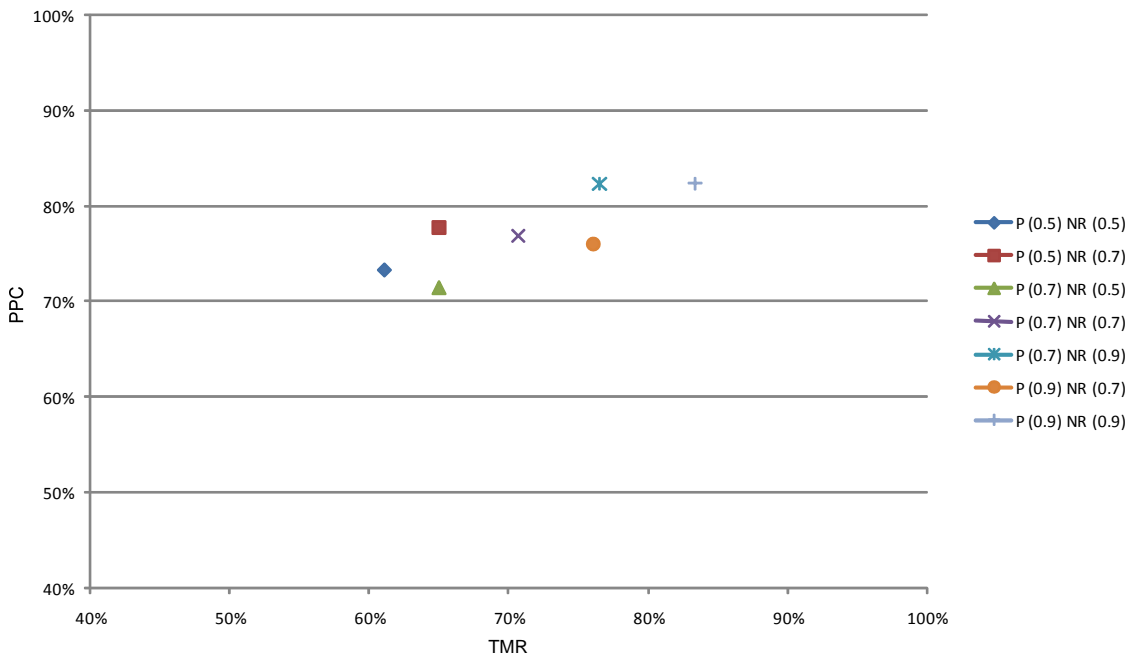

Figure 6.17: Results from Experiment 9 showing the relationship between TMR, P, NR and PPC.

The results presented in Figures 6.16 and 6.17 show a direct relationship between TMR and PPC. An increase in TMR results in an increase in PPC. However, the results show a

larger contribution by an increase in RR and NR on TMR than the impact caused by increasing R and P. This reinforces the results observed earlier and highlights the importance of making tasks ready compared to just anticipating tasks.

To further support the above argument, experiment 10 is designed to show the impact of RR and NR on TMR and ultimately on PPC. The experiment aims at gradually increasing TMR by increasing (RR, NR) from (0.5, 0.5) to (0.9, 0.9) and keeping other variables constant as shown in Table 6.10 and Figure 6.18.

Table 6.10: Variables and Parameters for Experiment 10 - Deterministic: TMR, RR, NR and PPC.

Parameter / Variable	Value
RockNoPerWeek	40
BreakDownNo	3
R	0.6
P	0.8
RR	0.5, 0.7, 0.9
NR	0.5, 0.7, 0.9
New	20
N	0.5

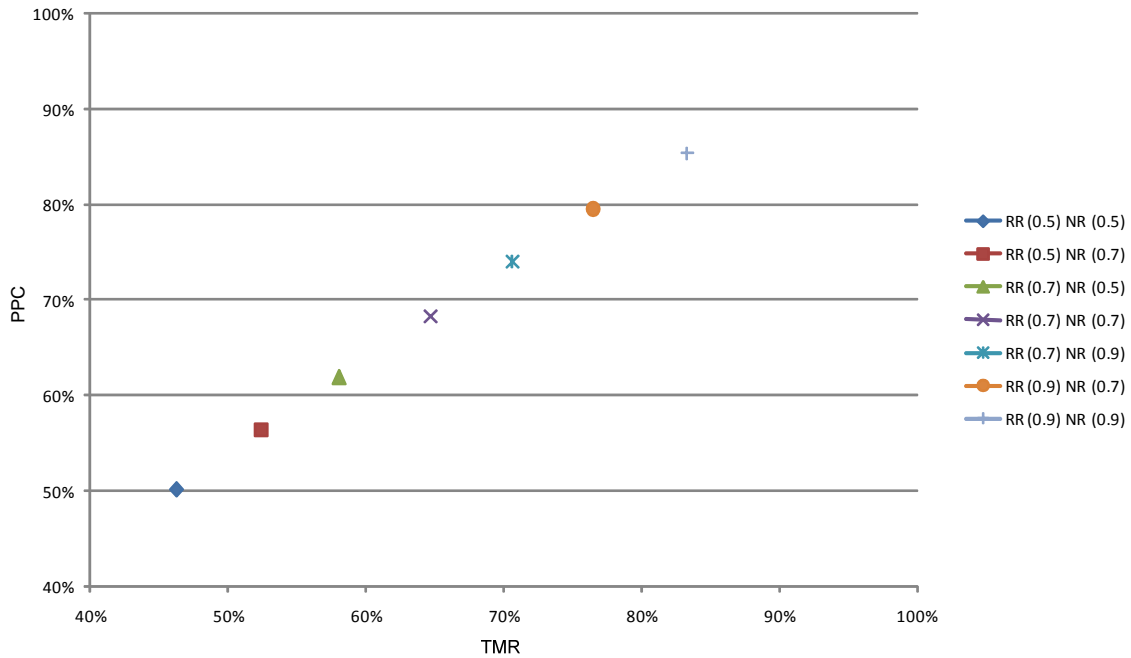

Figure 6.18: Results from Experiment 10 showing the relationship between TMR, RR, NR and PPC.

The results shown in Figure 6.18 highlight the direct impact of RR and NR on TMR and PPC. It supports the previous observations suggesting that an increase in PPC can be achieved by increasing TA, R, and P (i.e., improving lookahead planning two weeks, and one week ahead of execution) coupled by increasing TMR, RR, and NR (i.e., improving constraint removal during the execution week and insuring that the tasks labeled Ready are actually ReadyReady and free from constraints).

### 6.3 Summary of Simulation Results and Conclusions

This chapter studies the impact of certain planning processes within lookahead planning including: task breakdown, task anticipation, and constraint removal. A mathematical model expressing the flow of tasks between week 3 and week 0 is presented incorporating the relevant variables, parameters, and metrics.

Several simulation experiments studying the relationship between the different variables and their impact on PPC are performed. Simulation results are analyzed and

suggestions presented. Takeaways from these experiments and from the mathematical model are summarized and presented in the following:

- TMR (2, 1) = R cannot by itself express the performance of lookahead planning. A high R does not automatically guarantee a high PPC. It has to be coupled by a high RR. When RR is low (high uncertainty in constraint removal), increasing R does not help in increasing PPC. The same applies to P which needs to be coupled by a high NR.
- The impact of new tasks “New” on PPC is directly related to N. Therefore, it is recommended to avoid adding any new tasks to the weekly work plan unless it is high certain that those tasks are constraint-free or the constraints can be removed during the upcoming week.
- Breaking down and anticipating tasks have a positive impact on PPC as shown by the increase in PPC when TA is increased. In fact, increasing task anticipation provides lead time for removing constraints. However, increasing TA alone does not contribute considerably unless coupled by an increase in constraint removal (i.e., an increase in NR) and understanding the customers’ conditions of satisfaction when declaring constraint removal (i.e., an increase in RR).
- TMR is directly related to PPC. PPC is a combination of making tasks on the lookahead plan ready (represented by TMR) and making new tasks ready (represented by New \* N). Increasing TMR requires good task anticipation (high TA) combined by proper constraint removal and meeting customers’ conditions of satisfaction (high RR and NR).



- The relationship between execution failure and PPC is linear. If 90% of tasks suffer from failure during execution then 90% of tasks bound to be complete are completed. Accordingly, PPC is multiplied by a factor of 0.9.
- As Figure 6.7 presents, there are three main streams moving from lookahead planning towards task completion and ultimately contributing to PPC: (1) through (R and RR), (2) through (1-R, P, NR), and (3) through (New and N). These three streams represent three different types of work: (1) Type-1, (2) Type-2, and (3) Type-3.
- Type-1 work (stable) represents standardized, repetitive, and highly certain tasks. These tasks are similar to tasks in the manufacturing-like environment where tasks are standardized and constraints are well-known. An example of Type-1 tasks is the production of precast concrete or unitized curtain-wall elements. Type-1 tasks can be anticipated long before execution, constraints can be removed prior to the execution week, and it is highly certain that Ready tasks are actually ReadyReady. Accordingly, for this type a high R and RR, a low (1-R), and low New are expected. The (R, RR) stream is expected to be the highest contributor to PPC. An additional example of Type-1 work is also unique and highly critical tasks that require near-perfect planning and coordination. An example is lifting a chimney stack on an industrial project. This task requires careful preparation to make sure all prerequisites including cranes and human resources are available. Accordingly, such tasks are expected to be made ready and hence constraint-free long before execution. Ready tasks are meticulously inspected to insure all constraints are removed.

- Type-2 work (medium level of uncertainty) represents tasks that are less standard, involve a higher level of uncertainty than Type-1, and requires a lot of coordination. Such tasks include closure of false ceilings, the closure of wall using dry walls, and in-situ pouring of concrete slabs. This type of work involves a high percentage of tasks that are NotReady prior to the execution week (low R). Thus, most of the tasks are expected to be made ready during the execution week. Thus, NR should be high for these tasks to be made ready and completed during the execution week. Accordingly, this type of work contributes to PPC through the (1-R, P, NR) stream.
- Type-3 work (emergent) involves tasks that are highly uncertain. These tasks come from work previously done in a way that cannot be completely anticipated. Thus, a high level of new tasks is expected (high New) and high uncertainty in constraint removal and making tasks ready (low RR). An example of Type-3 work includes: creative work, marine works, offshore works, and other works that have highly uncertain prerequisites (e.g., information and weather). Type-3 tasks contribute to PPC by having a high level of N where tasks are made ready during the execution week. It is recommended that such tasks are enlisted on the weekly work plan only after incurring that constraints can be removed prior to task execution. Because RR is low, making tasks ready early (increase R) will not increase PPC. In reality, the presence of New tasks is unavoidable especially when the people developing the lookahead plan are not the same people executing the tasks.

As shown in Figure 6.1, this chapter studies the impact of lookahead planning on PPC. However, more experiments are required to study the impact of improving lookahead planning and increasing PPC on overall project performance. Further research is required to address this topic as mentioned in section 7.4.

#### **6.4 References**

- Axelrod, R. (2006). "Advancing the Art of Simulation in the Social Sciences", *Handbook of Research on Nature Inspired Computing for Economy and Management*, Jean-Philippe Rennard (Ed.), Idea Group, Hersey, PA, 13 pp.
- Dooley, K. (2002). "Simulation Research Methods", *Companion to Organizations*, Joel Baum (Ed.), Blackwell, pp. 829-848.
- Martinez, J.C. (1996). *STROBOSCOPE: State and Resource Based Simulation of Construction Processes*. Ph.D. Dissertation, Department of Civil and Environmental Engineering, University of Michigan, Ann Arbor, MI, 518 pp.
- Martinez, J.C. (2001). "EZSTROBE- General Purpose Simulation System Based on Activity Cycle Diagrams", *Proceedings of the 2001 Winter Simulation Conference*, pp. 1556-1564.
- Tommelein, I.D. (1998). "Pull-driven Scheduling for Pipe-spool installation: Simulation of a Lean Construction Technique". *Journal of Construction Engineering and Management*, ASCE, July/Aug., pp. 279-288.

## ***CHAPTER 7 - CONCLUSIONS AND RECOMMENDATIONS***

The Last Planner™ System (LPS), developed by Glenn Ballard and Greg Howell, is a production planning and control system used to assist in smoothing variability in construction work flow, developing planning foresight, and reducing uncertainty in construction operations. The system originally tackled variability in workflow at the weekly work plan level but soon expanded to cover the full planning and schedule development process starting with milestones and finishing with production plans including four stages of planning: master scheduling, phase scheduling, lookahead planning and weekly work planning.

Previous research reports positive impacts on workflow reliability and labor productivity when implementing the LPS. Possible secondary impacts reported include improvements in work safety and quality (Ballard and Howell 1994, Alarcon and Cruz 1997, Ballard and Howell 1998, Ballard et al. 2007, Liu and Ballard 2008). As designed, through the linking of Should, Can, Will, and Did as described in previous chapters, the LPS is intended to measure workflow reliability and to be a good indicator of both project progress and productivity.

However, the current use of the LPS on many construction projects shows a gap between long-term planning (master and phase scheduling) and short-term planning (lookahead planning and weekly work planning); thus reducing the capability of the planning system to develop foresight. The wider the gap is, the farther the weekly work plan is from executing activities that count towards achieving milestones and,

consequently, the lower is the ability of percent plan complete (PPC) to predict project progress or productivity (and hence performance against budget).

This study presents an assessment of the implementation of the LPS among system users, highlights some of the gaps in operating the planning system, emphasizes the role of lookahead planning as a prime driver to the success of weekly work planning, suggests guidelines for improving the lookahead planning process, and introduces an analytical model of the lookahead planning process.

This chapter highlights the study findings and presents recommendations for further improvement. Section 1 summarizes the major observations, conclusions and recommendations resulting from this research and relates them to three potential improvement areas: process-related, technical, and organizational. Section 2 lays out the lessons learned and contributions to knowledge accrued from the primary case study, the supporting case studies, the framework for lookahead planning execution, and the simulation model for lookahead planning. Finally, Section 3 presents the need for further research in this field.

## **7.1 Observations, Conclusions, and Recommendations**

During the course of this study I have recorded several observations from the case studies and simulation experiments, analyzed study results, developed conclusions, and proposed recommendations. I hereby report and summarize these observations / results, conclusions, and recommendations under three non-mutually exclusive areas: process-related, technical, and organizational.

## ***7.1.1 Process-Related Observations, Conclusions, and Recommendations***

### ***7.1.1.1 Observations***

- Absence of integrated and standardized planning processes. Planning processes are mostly informal and when standards do exist they are poorly followed.
- Top-down push of construction schedules. Upper echelon entities push schedules to lower echelon entities (e.g., owner to contractor, contractor to subcontractor, white collar to blue collar professionals). The cause is poor collaborative planning processes and the result is misalignment of schedules and misalignment in perception of value by project parties (e.g., owner, contractor, subcontractors) or personnel within an organization (e.g., white and blue collar professionals).
- Late implementation of constraint analysis (leaves short lead time to remove constraints). The cause is inadequate lookahead planning and the result is poor identification and removal of constraints.
- Poor linkage and alignment between long-term planning (i.e., master and phase scheduling) and short-term planning (i.e., lookahead and weekly work planning) reducing the ability of the planning system to support a reliable workflow and help project team members develop foresight.
- While Percent Plan Complete (PPC) (measures performance of weekly work planning) gives an indication of productivity, it does not give a proper indication of the overall project's performance when long-term planning and short-term planning are misaligned (i.e., when a discontinuity exists between Should, Can, Will, and Did).

- One method that construction professionals use in developing recovery schedules is running many tasks in parallel. This may cause many tasks to run simultaneously towards the end of the project.

#### 7.1.1.2 Conclusions

- Planning is a key process in designing, operating, and improving a production system. Most often the focus is on the plan and not the planning process. However, the planning process is more important than the outcome deliverable whether it is a schedule, an estimate, or a strategic plan. Planning is a continuous adaptive iterative process in quest for value. This conclusion is in line with Cohn's (2006) understanding of agile planning. He advocates the application of collaborative and fully democratic planning processes to: (1) reduce risk, (2) manage and reduce uncertainty, (3) support sound decision making, (4) establish trust, and (5) share information.
- Planning is a continuous process which involves a deliberative course of action that optimizes value (e.g., time, cost, and quality) and situated course of action to account for changes in the environment and the uncertainty affecting inputs, processes, and outputs. Therefore, planning involves continuous re-planning.
- The previous conclusion is synergetic with that of Smith (2003) who understands planning as a dynamic and iterative rather than static and deterministic. While planning is used to optimize performance of a system with limited resources over a period of time, the schedule (a product of planning) should be continuously relevant to current environment of the system. Unless the system's environment

is stable and static, schedules supposedly optimized well in advance of execution are certain to fail, so should be flexible enough to accommodate iterative and continuous re-planning.

- Project teams should develop a base plan but should also breakdown tasks and design operations as time gets close to performing the work (designing and making). Specifying a control plan below the level of milestones is not the function of master scheduling, in part because it is not feasible given the nature of forecasts and the stochastic nature of the world, and in part because of the critical importance of engaging those who will do the work in planning how to do it.
- Since uncertainty might decrease as time gets closer to executing a task, situated planning, task breakdown, and design of an operation is required closer to task execution. This conclusion is in harmony with the cone of uncertainty principle (McConnell 2008) indicating a reduction in uncertainty closer to execution as shown in Figure 7.1. However, this conclusion does not suggest avoiding task breakdown at the early stages of the project. In fact, quite a bit of breakdown is always required to get a good base plan. But this base plan can change and milestones in it can change with time as may be needed to meet the customers' value proposition.
- The LPS incorporates situated planning into lookahead planning and to a lesser extent into weekly work planning. When performing lookahead planning (i.e., breaking down tasks to the level of operations, identifying and removing constraints, and designing operations) the team is performing continuous re-



planning and incorporating changes in the environment to meet customers' value proposition.

- Breaking down and anticipating tasks have a positive impact on the success of weekly work planning and on PPC (i.e., increasing TA has an impact on increasing PPC). However, task anticipation and breakdown (increasing TA) does not contribute considerably to PPC unless combined with constraint removal (increasing TMR) and understanding the customers' conditions of satisfaction when declaring constraint removal.

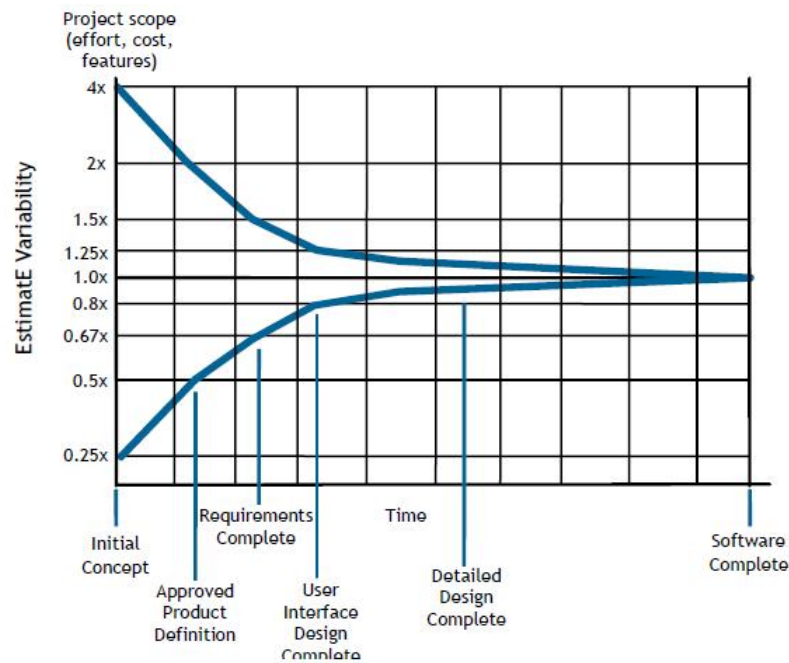

Figure 7.1: The cone of uncertainty in software projects (McConnell 2008).

- For successful situated planning, lookahead planning and weekly work planning should incorporate a continuous improvement process by analyzing plan failures, finding root causes, and suggesting improvement strategies that prevent the same type of failures from recurring.

- Different types of work (e.g., Type-1, Type-2, and Type-3 as defined in Chapter 6) have different values of R, P, RR, NR, New, N, TA, and TMR as defined in Chapter 6. However, all three types are manageable using the LPS.

#### 7.1.1.3 Recommendations

- While the study suggests that the LPS principles account for both deliberative and situated action models it also emphasizes the need to apply the LPS rules in industry practice namely: (1) plan in greater detail as you get closer to performing the work, (2) develop the work plan with those who are going to perform the work, (3) identify and remove work constraints ahead of time as a team to make work ready and increase reliability of work plans (4) make reliable promises and drive work execution based on coordination and active negotiation with trade partners and project parties, and (5) learn from planning failures by finding the root causes and taking preventive actions (Ballard et al. 2007).
- This study advocates implementing the LPS holistically in its four planning stages: master scheduling, phase scheduling, lookahead planning, and weekly work planning as presented in Chapter 5.
- This study emphasizes the proper implementation of lookahead planning by breaking down tasks to the level of operations, identifying and removing constraints, and designing operations. It is recommended to increase PPC using three different methods for three different types of work. For Type-1 work (stable and predictable) increasing TA by increasing R can increase PPC since RR is high for this type of work. For Type-2 work (less stable and interdependent

work) increasing TA on its own is not enough. Thus, increasing TMR is required by improving constraint removal closer to task execution. For Type-3 work (emergent) the most significant way to increase PPC is to increase the chances for new tasks to be performed by increasing the agility of the team in removing constraints within a short period of time. New tasks that are constrained and highly uncertain are better left out of the weekly work plan and not assigned labor or resources to them.

## ***7.1.2 Technical Observations, Conclusions, and Recommendations***

### ***7.1.2.1 Observations***

- Poor performance of scheduling software packages in enabling schedule coordination and real-time feedback. Software programs currently used in construction do not fully support deliberative and situated planning that are inherent to the LPS. While most software enable deliberative planning using the Critical Path Method (CPM) or Line of Balance (LOB) scheduling techniques, they do not support the development of lookahead plans or weekly work plans coming out of base milestones. Moreover, schedule coordination requires inputs from industry professionals at different levels (e.g., blue collar and white collar professionals) and from different project parties (e.g., owner, contractor, subcontractor, and designer). Since the utility of any tool, such as a planning software package, increases exponentially in proportion to the number of professionals using it, schedules should be used, studied, and adjusted by the whole team. Moreover, when the whole team is using a common software

platform to perform planning, schedule updates can be performed in real-time by those doing the work, thereby eliminating the need for planning gurus who monopolize project planning and perform infrequent schedule updates.

#### *7.1.2.2 Conclusions*

- The construction industry is in dire need for planning software that enable schedule coordination and real-time updating. Thus eliminating the use of multiple planning software platforms that poorly interact with each other.

#### *7.1.2.3 Recommendations*

- Support the development of new planning software programs that enable: (1) schedule coordination and sharing, (2) collaborative planning, (3) real-time updating, (4) deliberative and situated planning, (5) the application of the LPS principles, (6) lookahead planning founded in the master schedule, and (7) weekly work planning grounded in lookahead plans.
- Develop the planning process (e.g., the planning process presented in Chapter 3) before implementing planning software applications. Team members should buy into the planning process and understand its value prior to performing team planning.

### ***7.1.3 Organizational Observations, Conclusions, and Recommendations***

#### *7.1.3.1 Observations*

- Modest organizational learning on projects and from project to project. Learning is limited to individuals with minimal recorded experiences in terms of

standardized process, best industry practices, and preventive actions taken to prevent previous failures from recurring.

- The experience of project parties in lean methods and the LPS is a major enabler of collaborative planning, teamwork, and constraint removal on a construction project. Therefore, training is crucial to the successful implementation of the LPS.
- A major success factor in driving the implementation of LPS and in leading continuous improvement efforts is strong leadership. Leadership, which represents the upper management's commitment to a successful implementation, is the driving engine that enables an organization to overcome breakdowns when implementing a novel process.
- While applying new planning processes poses serious challenges to team members, introducing a new technology creates additional complications.
- Resistance to change is inherent to implementing novel process in any organizational setting. This applies to implementing the LPS.

#### *7.1.3.2 Conclusions*

- Since the LPS challenges the old planning practices of pushing schedules from top management down to frontline professionals to execute and empowers frontline professionals (last planners) to plan their work, resistance to its implementation is expected. Therefore, it is the responsibility of top management to motivate the organization to embrace the new process by showing strong leadership and commitment in everyday practices.

- Zammuto and Krackower (1991) claim that resistance to change is closely related to inertia. The higher the inertia is in an organization, the stronger the belief is of individuals in an organization that they will do the same thing tomorrow as they are doing today. Therefore, one method to mitigate the momentum of inertia in an organization is for top management to demonstrate their willingness to adopt change and most importantly reward individuals for adopting novel processes.
- The LPS is not only a system for production planning and control but also an enabler for social exchange on construction projects. It institutionalizes coordination and communication, incorporates them into everyday activities, and builds them into the managerial structure; thus reinforcing collaborative project planning and control, team building, and continuous improvement.
- The successful implementation of LPS requires changes in the mindset of individuals in an organization and in social exchanges between individuals to build a network of trust reinforced by everyday activities and practices of top management.

#### *7.1.3.3 Recommendations*

- Applying the LPS on a given project is a lengthy process and requires strong commitment from the project owners and top management. To facilitate the transition, it is recommended to tailor the method to project circumstances, needs, and conditions. To customize the LPS process to a given project it is recommended to: (1) designate a kick-off team to launch LPS implementation, (2) develop and implement a training program, (3) provide a positive experience

during initial implementation, (4) involve last planners from all project parties, (5) perform regular training classes as users become more advanced, (6) meet regularly to evaluate the process and compare status to target goals, (7) introduce adjustments and improvements.

## **7.2 Research Findings**

This study has explored planning processes in construction production systems and focused on the application of the LPS. Chapter 3 introduced an example of best industry practices implementing the LPS. It described a new approach to lookahead planning developed on a current project to better connect weekly work plans to the master schedule. Chapter 4 presented results from three projects exposing issues in the current implementation of the LPS. Chapter 5 introduced a framework for implementing the LPS on construction projects with operational steps to improve lookahead planning and increase the connectedness of weekly work plans to the master schedule. Chapter 6 laid down an analytical model to show the importance of lookahead planning steps (task breakdown and anticipation, identifying and removing constraints, and designing operations) on improving weekly work planning and increasing PPC.

However, this research will be incomplete unless it answers the research questions posed in Chapter 1. While this whole study intends to answer these questions, the following summarizes these answers:

**Question 1:** What are the reasons behind the poor link between weekly work plans and the master schedule and what causes PPC to become a poor predictor of project performance?

Chapters 1, 3, and 4 present research results from five case study projects highlighting deficiencies in planning processes when implementing the LPS. These deficiencies include: poor weekly work planning, inadequate development of weekly work plans due to poor phase scheduling and lookahead planning processes, and the inability to learn from planning failures.

Poor weekly work planning is related to deficiencies in making quality assignments. Making quality assignments requires incorporating on the weekly work plan only tasks that are well defined, constraint-free, in proper sequence, and well sized (i.e., matching load and capacity).

A poor phase scheduling process produces a schedule that does not adequately represent the work required as per the master schedule to deliver a milestone or a phase. A variety of factors contribute to this poor performance including: absence of real collaborative planning, the failure of phase schedule tasks to express the value expected by the customer, inadequate assignment and sequence of tasks, inadequate reverse phase scheduling, and inadequate distribution of float.

A poor lookahead planning process fails to properly breakdown tasks on the master / phase schedule; fails to identify and remove constraints; fails to anticipate tasks so they can be made ready; fails to design operations and test those designs in first run studies.

Inability to learn from plan failures is attributed to not understanding the reasons of plan failures and hence the inability to develop preventive measures to avoid the recurrence of such failures.



**Question 2:** How to structure the lookahead planning process to increase PPC while increasing the connectedness of weekly work plans to the master schedule and making PPC a better predictor of project success?

Chapter 5 presents a framework for implementing the LPS, detailing operational steps that an organization can customize to their project needs. The framework comprise guidelines for the four LPS process: master scheduling, phase scheduling, lookahead planning, and weekly work planning. Master scheduling involves developing logistics plans and work strategies prior to setting project milestones. Phase scheduling builds on the milestones set in master scheduling to define milestone deliverables, breakdown milestones into constituent activities, perform collaborative reverse phase scheduling, and adjust the schedule to meet the available time frame. Lookahead planning starts by taking a lookahead filter from the phase schedule then breaking processes into operations, identifying and removing constraints, and designing operations (with the use of first run studies). Weekly work planning engages stakeholder last planners in applying quality criteria for selecting tasks to go on the weekly work plan, exercising reliable promising, and learning plan failures.

Chapter 3 presents an example of a successful LPS implementation representing a best-case practice in industry. Lessons learned from performing research on this project case study were incorporated into the LPS framework presented in Chapter 5.

Chapter 6 introduces an analytical model for lookahead planning three weeks ahead of execution. Several experiments are performed to show the impact of lookahead planning steps on the success of weekly work planning. They confirm the utility of TA and TMR as performance metrics for lookahead planning and show the positive impact of

increasing TA and TMR on increasing PPC. The experiments also show the dynamics of the lookahead planning process and its implications on different types of work. Results reveal the need to perform lookahead planning differently for three types of work involving different levels of uncertainty: stable work, medium uncertainty work, and highly emergent work.

### **7.3 Contributions to Knowledge**

This study provides a better understanding of reasons responsible for the poor linkage between weekly work plans and master schedules. It traces back these reasons to poor implementation of the LPS in industry practice. After observing and reporting the deficiencies in implementing the LPS on construction projects, a new framework for the LPS was developed and tested on a construction project. An analytical model for lookahead planning three weeks ahead of execution was used to show the importance of each step in the lookahead planning process.

This research helps increase the understanding of the role of planning in production systems to better manage the work of designing and making. While the study contributes to improving the last planner system, it is a step on the way of continuous improvement. It is expected to not only contribute on the practical level by examining and suggesting ways to enhance the quality of planning, increase communications, and improve work reliability but also contribute on the academic level by introducing an analytical model to study the lookahead planning process. This model can be further developed to cover the overall LPS, give insights into planning deficiencies, and suggest improvement strategies.

The following sections summarize the major contributions to knowledge from this research.

### ***7.3.1 Contributions of the Supporting Case Studies***

The supporting case studies presented in Chapter 4 and the pilot case study presented in Chapter 1 provide insights into planning practices in the construction industry and expose many planning related issues including: absence of standardized and institutionalized planning processes, top-down push of construction schedules, late recognition and removal of constraints, and minimal organizational learning.

Research results from the case studies also exposed a major problem in construction planning related to running many tasks in parallel when developing recovery schedules in response to schedule delays. While scheduling tasks in parallel might help in developing recovery schedules, running these tasks simultaneously may pose serious challenges in execution compromising productivity, quality, and profitability. This issue might be more severe towards the end of the project where many tasks are run simultaneously to finish with the project end date.

The major contribution of these case studies is uncovering the poor link between weekly work plans and the master schedule. This discovery lead the way to developing improvement strategies in lookahead planning.

### ***7.3.2 Contributions of the Primary Case***

The primary case study, presented in Chapter 3, was a testing laboratory for potential strategies to improve lookahead planning and the LPS. Many of the new additions to the

LPS implementation process detailed in the LPS framework in Chapter 5 were developed and tested on this project case study.

The primary case study also exposed major execution problems specifically related to social issues, leadership, and resistance to change. One contribution in this field is the delineation of execution steps, discussed in Chapter 5, to facilitate the implementation of the LPS.

Another contribution of this case study is uncovering the deficiencies in current scheduling software to fully enable schedule coordination and real-time feedback which are required nowadays in collaborative project environments.

### ***7.3.3 Contributions of the Framework for Implementing the Last Planner System***

The framework presents the LPS in operational steps and highlights the purpose of master scheduling, phase scheduling, lookahead planning, and weekly work planning. The biggest contribution of Chapter 5 is developing guidelines for performing lookahead planning and supporting the process with methods to measure performance.

The guidelines present a comprehensive framework of the LPS and a visually supported model for developing schedules starting from milestones and finishing with weekly tasks. The framework received positive feedback from industry professionals who reviewed the manuscript and is expected to help the industry develop a better understanding of the role that lookahead planning plays in production management and control.

### **7.3.4 Contributions of the Simulation Experiments**

The analytical model presented in Chapter 6 is a simplified model of lookahead planning. It shows the impact of lookahead planning steps and the dynamics involved on weekly work planning. The model brings more transparency into the planning steps performed during lookahead planning: task breakdown and anticipation, constraint identification and removal, and operations design.

While field research did not present enough evidence for the impact of lookahead planning performance on PPC, simulation experiments showed that potential improvements in PPC are possible when improving TA and TMR.

Perhaps the biggest contribution of the model is demonstrating that the LPS rules apply to different types of work (stable, less stable, and emergent work) and accommodate the key challenges of each. The model suggests that different types of work dictate different ways of planning while all being manageable within a single production planning and control system.

## **7.4 Further Research**

While this research has studied the lookahead planning process and its role in increasing the linkage between short-term planning and long term planning, further research is required to understand the impact of lookahead planning on overall project performance. As figure 7.2 shows, the scope of this research is to study the impact of lookahead planning on weekly work planning and the impact of lookahead planning metrics TA and TMR on PPC.

Further research is required to study the impact of lookahead planning on master schedule performance (e.g., how would increasing TA or TMR impact delays or gains on

the master schedule?). While previous research has confirmed the positive impact of increasing PPC on crew productivity and this study has confirmed the impact of TA and TMR on PPC, future research is required to study how implementing the LPS and applying the LPS rules of practice can improve schedule performance. A simulation model representing the full planning cycle would be beneficial in modeling the dynamics of the system and providing useful insights on improving industry practices. Moreover, further research is also required to validate the characterization of types of work (i.e., types 1, 2, and 3) in practice. Also future research should incorporate stochastic modeling especially that the model presented in Chapter 6 is suitable for it.

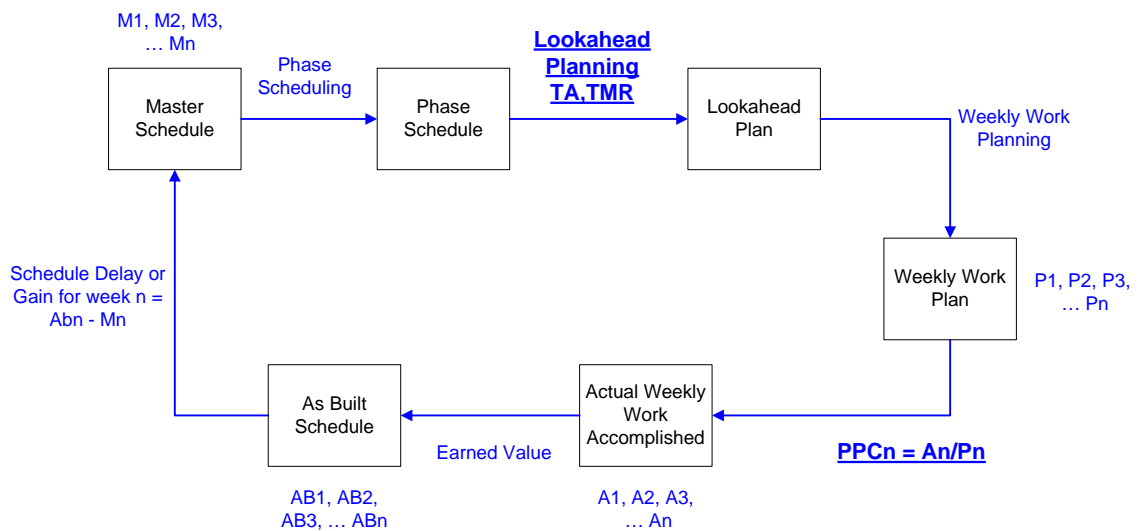

Figure 7.2: The planning cycle using the LPS.

One area that demands future research is investigating and comparing the make ready process for tasks produced by the lookahead planning process versus newly added tasks to the weekly work plan that were not envisioned in the lookahead planning process. Further research is required to study the reasons for having New tasks on weekly work plans. This study will shed more light on current industry practices, uncover deficiencies, and suggest improvements.

One of the planning challenges identified by this study is the planning process required to plan ‘creative design’ tasks. These tasks are defined in this study as tasks requiring a high degree of innovation, originality, creativity, inspiration, design incubation time, and design talent. ‘Creative design’ tasks are very difficult to plan and monitor due to uncertainty in duration and scope of the work involved. They depend more on the inspiration of the designer than on the time spent performing the design. Since a ‘creative design’ task may sometimes span over several weeks depending on the designer’s inspiration, scheduling these tasks by assuming certain man-day load and dividing it by a certain human resource capacity will not suffice to give an accurate estimate of duration. Further research is required to structure the planning process to tackle such design tasks.

## 7.5 References

- Alarcón, L. F., and Cruz, J. C. (1997). "The Impact of Project Planning Performance on Project Outcomes", *Tenth World Productivity Congress*, October, Santiago, Chile, pp. 12-15.
- Ballard, G., and Howell, G. (1994). "Implementing Lean Construction: Stabilizing Workflow", *Proceedings of the 2nd Annual Conference of the International Group for Lean Construction, IGLC 2*, Santiago, Chile. In: *Lean construction (1997)*, edited by Luis F. Alarcón C. A A Balkema, Rotterdam.
- Ballard, G., and Howell, G. (1998). "Shielding Production: An Essential Step in Production Control", *Journal of Construction Engineering and Management*, ASCE, 124 (1), pp. 11-17.
- Ballard, G., Kim, Y.W., Jang, J.W., and Liu, M. (2007). *Road Map for Lean Implementation at the Project Level, Research Report 234-11*, Construction Industry Institute, The University of Texas at Austin, Texas, USA, 426 pp.

- Cohn, M. (2006). *Agile Estimating and Planning*. Prentice Hall Professional Technical Reference, NJ, pp. 330.
- Liu, M., and Ballard, G. (2008). "Improving Labor Productivity Through Production Control", *Proc. 16<sup>th</sup> Ann. Conf. Int'l. Group for Lean Constr., IGLC 16*, 16-18 July, Manchester, UK.
- McConnel, S. (2008). "Software Development's Cone of Uncertainty", *Best Practices White Paper*, Construx Software Builders Inc., WA, 8 pp.
- Smith, S.F. (2003). "Is Scheduling a Solved Problem?" *Proceedings of the First Multi-Disciplinary International Conference on Scheduling: Theory and Applications (MISTA 03)*, August, Nottingham, UK, 16 pp.



## ***APPENDIX - INDUSTRY SURVEY RESULTS***

1. What is your organization's function?(please tick what applies to your organization on the current project)		
	Response Percent	Response Count
Owner	15.2%	20
Designer/Consultant	19.7%	26
Contractor/Subcontractor	48.5%	64
CM/PM	28.8%	38
other	6.1%	8
<i>answered question</i>		132
<i>skipped question</i>		1

2. What is your current job position?		
	Response Percent	Response Count
Project management level	62.1%	82
Technical staff	8.3%	11
Supervisory(field)	9.8%	13
other	27.3%	36
<i>answered question</i>		132
<i>skipped question</i>		1

3. For what phase do you implement the Last Planner System? (Please tick all what applies)		
	Response Percent	Response Count
Project definition	14.6%	15
Design	45.6%	47
Prefabrication	26.2%	27
Construction	90.3%	93
Use	6.8%	7
<i>answered question</i>		103
<i>skipped question</i>		30

**4. Which of the following is part of your planning process? (please tick all what applies)**

	Response Percent	Response Count
Master scheduling	76.2%	80
Phase scheduling (pull)	78.1%	82
Lookahead planning	85.7%	90
Weekly work plan	81.0%	85
other	9.5%	10
<i>answered question</i>		<b>105</b>
<i>skipped question</i>		<b>28</b>

**5. For what phases are you performing phase scheduling?**

	Response Percent	Response Count
Project Definition	26.5%	27
Design	50.0%	51
Foundations	60.8%	62
Structure	70.6%	72
Finishing	69.6%	71
Closeout	43.1%	44
other	15.7%	16
<i>answered question</i>		<b>102</b>
<i>skipped question</i>		<b>31</b>

**6. Which software you are using?**



	Response Percent	Response Count
for preparing/presenting the master schedule	98.9%	93
for preparing/presenting the lookahead schedule	97.9%	92
for preparing/presenting the weekly schedule	93.6%	88
<i>answered question</i>		<b>94</b>
<i>skipped question</i>		<b>39</b>

7. What is the span of the lookahead schedule you are developing?		
	Response Percent	Response Count
6 weeks	61.2%	60
5 weeks	1.0%	1
4 weeks	11.2%	11
3 weeks	18.4%	18
2 weeks	8.2%	8
other	8.2%	8
<i>answered question</i>		98
<i>skipped question</i>		35



8. Who are the parties involved in preparing the Lookahead schedule? (Please tick all what applies)		
	Response Percent	Response Count
Owner	35.7%	35
Designer/consultant	34.7%	34
Contractor	81.6%	80
Subcontractors	72.4%	71
CMPM	42.9%	42
Suppliers	18.4%	18
Others	7.1%	7
<i>answered question</i>		98
<i>skipped question</i>		35

9. Who are the staff involved in preparing the Lookahead schedule? (Please tick all what applies)		
	Response Percent	Response Count
Project Manager	63.9%	62
Project Engineer	56.7%	55
Superintendent	78.4%	76
Foremen	47.4%	46
other	11.3%	11
<i>answered question</i>		97
<i>skipped question</i>		36

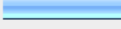

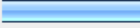
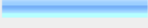
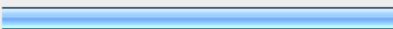
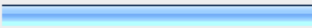

**10. Where do the activities on the lookahead schedule come from? (Please tick all what applies)**

	Response Percent	Response Count
directly from master schedule 	34.0%	33
directly from phase schedule 	51.5%	50
breakdown from master schedule 	50.5%	49
other 	21.6%	21
<i>answered question</i>		97
<i>skipped question</i>		36



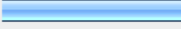

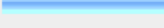
**11. From what tasks do last planners prepare the weekly schedule? (Please tick all what applies)**

	Response Percent	Response Count
breakdown from master schedule 	25.3%	23
breakdown from phase schedule 	26.4%	24
breakdown from lookahead schedule 	72.5%	66
expectations of next week work based on open work and available resources 	57.1%	52
other 	6.6%	6
<i>answered question</i>		91
<i>skipped question</i>		42

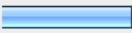
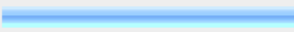

**12. When tasks are entered into the weekly work plan they maintain the same level of detail of as those on the lookahead schedule:**

	Response Percent	Response Count
strongly agree 	14.3%	13
agree 	33.0%	30
neither agree nor disagree 	16.5%	15
disagree 	29.7%	27
strongly disagree 	6.6%	6
<i>answered question</i>		91
<i>skipped question</i>		42

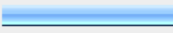
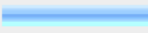

**13. PPC (percent planned complete) is an important indicator how the project is progressing:**

	Response Percent	Response Count
strongly agree 	23.7%	22
agree 	54.8%	51
neither agree nor disagree 	16.1%	15
disagree 	4.3%	4
strongly disagree 	1.1%	1
<i>answered question</i>		93
<i>skipped question</i>		40

**14. What percentage of constraints are identified and removed at the weekly work plan level?**

	Response Percent	Response Count
$\geq 75\%$ 	15.9%	14
$\geq 50\%$ but $< 75\%$ 	31.8%	28
$\geq 25\%$ but $< 50\%$ 	27.3%	24
$< 25\%$ 	12.5%	11
other 	12.5%	11
<i>answered question</i>		88
<i>skipped question</i>		45

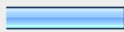
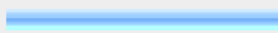
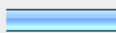
**15. Do you analyze reasons for plan variance?**

	Response Percent	Response Count
No 	21.5%	20
Yes & determine failure categories 	51.6%	48
Yes & perform root cause analysis 	20.4%	19
other 	6.5%	6
<i>answered question</i>		93
<i>skipped question</i>		40

## ***REFERENCES***

- AIA California Council (2007). "Integrated Project Delivery: A Working Definition Version 1", AIA California Council, 12 pp.
- Alarcón, L. F. (1993). "Modeling Waste and Performance in Construction." *Proceedings of the 1st Annual Conference of the International Group for Lean Construction*, Espoo, Finland.
- Alarcón, L. F. (1994). "Tools for Identification and Reduction of Waste in Construction Projects." *Proceedings of the 2nd Annual Conference of the International Group for Lean Construction, IGLC 2*, 28-30 September, Santiago, Chile.
- Alarcón, L. F. (1995). "Training field personnel to identify waste and improvement opportunities in construction." *Proceedings of the 3rd Annual Conference of the International Group for Lean Construction*, Albuquerque, N.M.
- Alarcon, L. F. (editor) (1997). *Lean Construction*. A.A. Balkema, Rotterdam, The Netherlands, 497 pp.
- Alarcón, L. F., and Cruz, J. C. (1997). "The Impact of Project Planning Performance on Project Outcomes", *Tenth World Productivity Congress*, October, Santiago, Chile, pp. 12-15.
- Alves, T.C.L. (2005) *Buffering Practices in HVAC Supply Chains*. Ph.D. Dissertation- Civil and Environmental Engineering, University of California, Berkeley, U.S.A.
- Arbulu, R., and Ballard, G. (2004). "Lean Supply Systems in Construction". *12th International Group for Lean Construction Conference*, Elsinore, Denmark.
- Aristotle (350 B.C. / 1970). *Aristotle's Physics Books I & II*. Translated with introduction and notes by W. Charlton, Clarendon P., Oxford, pp. 151.
- Ayers, J.B. (2006). *Handbook of Supply Chain Management*. 2<sup>nd</sup> Edition, Auerbach Publications, Boca Raton, FL, 608 pp.
- Ballard, G., (1997). "Lookahead Planning: The Missing Link in Production Control", *Proceedings of the 5th Annual Conference of the International Group for Lean Construction, IGLC 5*, July, Gold Coast, Australia.

- Ballard, G. (2000a). *The Last Planner System of Production Control*. Ph.D. Thesis, Faculty of Engineering, School of Civil Engineering, The University of Birmingham.
- Ballard, G. (2000b). "Lean Project Delivery System." *Lean Construction Institute*, White Paper No.8, Ketchum, Id. <http://leanconstruction.org/pdf/WP8-LPDS.pdf>
- Ballard, G. (2000c). "Phase Scheduling" White Paper #7, *Lean Construction Institute*, April 27, 3pp.
- Ballard, G., (2006). "Rethinking Project Definition in Terms of Target Costing," *Proceedings of the 14th annual conference of the International Group for Lean Construction*, July, pp. 77-89.
- Ballard, G., Hammond, J., and Nickerson, R. (2009). "Production Control Principles", *Proc. 17<sup>th</sup> Annual Conf. Intl. Group for Lean Construction*, Taipei, Taiwan.
- Ballard, G., and Hamzeh, F.R. (2007). "The Last Planner Production Workbook-Improving Reliability in Planning and Workflow", 2<sup>nd</sup> Edition, *Lean Construction Institute*, San Francisco, California, USA, pp. 81.
- Ballard, G., and Howell, G. (1994). "Implementing Lean Construction: Stabilizing Workflow", *Proceedings of the 2nd Annual Conference of the International Group for Lean Construction, IGLC 2*, Santiago, Chile. In: *Lean construction (1997)*, edited by Luis F. Alarcón C. A A Balkema, Rotterdam.
- Ballard, G., and Howell, G. (1998). "Shielding Production: An Essential Step in Production Control", *Journal of Construction Engineering and Management*, ASCE, 124 (1), pp. 11-17.
- Ballard, G., and Howell, G. (2003). "Competing Construction Management Paradigms". Proceeding of *Construction Research Congress, Winds of Change: Integration and Innovation in Construction*, HI, U.S.A., pp. 321-328.
- Ballard, G., and Howell, G. (2004). "An Update on Last Planner", *Proc. 11th Annual Conf. Intl. Group for Lean Construction*, Blacksburg, Virginia, USA, 13 pp.
- Ballard, G., Kim, Y.W., Jang, J.W., and Liu, M. (2007). *Road Map for Lean Implementation at the Project Level, Research Report 234-11*, Construction Industry Institute, The University of Texas at Austin, Texas, USA, 426 pp.

- Ballard, G., Koskela, L., Howell, G., and Zabelle, T. (2001). "Production system design: Work structuring revisited." *White Paper-11*, Lean Construction Institute, Ketchum, Id.
- Ballard, G., Koskela, L., Howell, G. A., and Tommelein, I. D. (2005). "Discussion of Improving Labor Flow Reliability for Better Productivity as Lean Construction Principle", *Journal of Construction Engineering and Management*, ASCE, May, pp. 615-616.
- Ballard, G., Tommelein, I. D., Koskela, L., and Howell, G. (2003). *Lean Construction Tools and Techniques (Chapter 15) of Design and Construction: Building in Value*, Butterworth Heinemann, pp. 227-255.
- Baudin M. (2004). *Lean Logistics - The Nuts and Bolts of Delivering Materials and Goods*, Productivity Press, New York, NY, 387 pp.
- Bernard, H.R. (2000) *Social Research Methods- Qualitative and Quantitative Approaches*, Sage Publications, Thousand Oaks, Ca, 659 pp.
- Bertelsen, S., Koskela, L., Heinrich, G., and Rooke, J.(2006)" Critical Flow – Towards a Construction Flow Theory". *Proceedings of the 14th Annual Conference of the International Group for Lean Construction, IGLC 14*, Santiago, Chile
- Bowersox, D.J., Closs, D.J., and Cooper, M.B. (2007). *Supply Chain Logistics Management*. Second Edition, McGraw-Hill/Irwin, NY, 410 pp.
- Cheshire, C. (2007) *Quantitative Research Methods*, IS 271 B course notes, University of California at Berkeley.
- CHPR (2008). "Cathedral Hill Pulse Report", Integrated Project Delivery Team, Cathedral Hill Hospital Project, December, San Francisco, CA, 10 pp.
- Cohn, M. (2006). *Agile Estimating and Planning*, Prentice Hall Professional Technical Reference, Upper Saddle River, New Jersey, 330 pp.
- Creswell, J.W., (2003). *Research Design- Qualitative, Quantitative, and Mixed Methods Approaches*, second edition, Sage Publications, Thousand Oaks, CA, 246 pp.
- Crichton, C. (1966). *Interdependence and Uncertainty: A study of the building industry*. Tavistock Institute, Tavistock Pubs., London, pp. 83.
- Cristopher, M. (1998) *Logistics and Supply Chain Management- Strategies for Reducing Cost and Improving Service*. 2<sup>nd</sup> Edition, Prentice Hall Financial Times, UK, pp. 294.



- Daft, R. (1991). *Management*. Dryden Press, Chicago, 744 pp.
- Elfving, J. (2003) *Application of Lean Methods in Reducing Lead Times for Engineered-To-Order Products*. Ph.D. Dissertation- Civil and Environmental Engineering, University of California, Berkeley, U.S.A.
- Elfving, J.A., and Tommelein, I.D. (2003) "Construction engineering and project management II: impact of multitasking and merge bias on procurement of complex equipment", *Winter Simulation Conference 2003*, pp. 1527-1533.
- Flores, F. (1982). *Management and Communication in the Office of the Future*, PhD Dissertation, University of California at Berkeley.
- Formoso, C.T., Soibelman, L., De Cesare, C., Isatto, E.L. (2002)"Material Waste in Building Industry: Main Causes and Prevention", *Journal of Construction Engineering and Management*, July/August, pp. 316- 325.
- Gilbreth, F.B., and Gilbreth, L.M. (1922) "Process Charts and Their Place in Management." *Mechanical Engineering*, January, pp. 38-41.
- Glatthorn, A.A., and Joyner, R. L. (2005). *Writing the Winning Thesis or Dissertation- A Step-by-Step Guide*, second edition, Corwin Press, Thousand Oaks, CA, 268 pp.
- Gliner, J.A., and Morgan, G.A. (2000) *Research Methods in Applied Settings: An Integrated Approach to Design and Analysis*, Lawrence Erlbaum Associates Publishes, NJ, 465 pp.
- Gonzalez, V., Alarcon, L.F., and Mundaca, F. (2008). "Investigating the relationship between planning reliability and project performance", *Production Planning & Control*, Vol. 19, No.5, July, pp. 461-474.
- Gourdin, K.N. (2006). *Global Logistics Management: A Competitive Advantage for the 21st Century*. Second Edition, Blackwell Publishers, Malden, MA, 318 pp.
- Green, S.D., Fernie, S., and Weller, S. (2005) "Making Sense of Supply Chain Management: A Comparative Study of Aerospace and Construction". *Construction Management and Economics*, July, pp. 579-593.
- Hamzeh, F.R., Tommelein, I.D., Ballard, G., and Kaminsky, P. (2007). "Logistics Centers to Support Project-Based Production in the Construction Industry", *Proceedings of the 15th Annual Conference of the International Group for Lean Construction, IGLC 15*, 18-20 July, East Lansing, Michigan, USA, pp. 181-191.

- Hamzeh, F.R., Ballard, G., and Tommelein, I.D. (2008). "Improving Construction Workflow- The Connective Role of Lookahead Planning", *Proc. 16<sup>th</sup> Ann. Conf. Int'l. Group for Lean Constr., IGLC 16*, 16-18 July, Manchester, UK, pp. 635-646.
- Hinze, J.W. (2008). *Construction Planning and Scheduling*. Pearson Prentice Hall, Upper Saddle River, New Jersey, 374 pp.
- Hannan, M.T., and Freeman, J. (1977) "The Population Ecology of Organizations", *The American Journal of Sociology*, Vol. 82, No. 5, March, pp. 929-964.
- Hopp, W.J., and Spearman, M.L. (1996). *Factory Physics*, 1<sup>st</sup> Ed., Irwin, Chicago, 668 pp.
- Hopp, W.J., and Spearman, M.L. (2004). "To Pull or not to Pull: What is the Question?" *Manufacturing & Service Operations Management*, Volume 6, Issue 2, pp. 133-148.
- Hopp, W.J., and Spearman, M.L. (2008). *Factory Physics*, 3<sup>rd</sup> Ed., Irwin/ McGraw-Hill, Boston, 720 pp.
- Horman, M. J., and Kenley, R. (2005). "Quantifying Levels of Wasted Time in Construction with Meta-Analysis", *Journal of Construction Engineering and Management*, ASCE, Jan., pp. 52-61.
- Horman, M. J., and Thomas, R. (2005). "Role of Inventory Buffers in Construction Labor Performance," *Journal of Construction Engineering and Management*, ASCE, July, pp. 834-843.
- Howell, G. A. and Ballard, G., (1994a). "Implementing Lean Construction: Reducing Inflow Variation", *Proceedings of the 2nd Annual Conference of the International Group for Lean Construction, IGLC 2*, 28-30 September, Santiago, Chile.
- Howell, G. A. and Ballard, G., (1994b). "Lean Production Theory: Moving Beyond Can-Do", *Proceedings of the 2nd Annual Conference of the International Group for Lean Construction, IGLC 2*, 28-30 September, Santiago, Chile.
- Howell, G. and Ballard, G. (1998) "Implementing Lean Construction: Understanding and Action" *Proc. 7<sup>th</sup> Ann. Conf. Int'l. Group for Lean Constr.*, Guaruja, Brazil.
- IFOA (2008). "Integrated Form of Agreement", Integrated Project Delivery Team, Cathedral Hill Hospital Project, San Francisco, CA.
- Kemmer, S.L., Heineck, L.F.M., Novaes, M.V., Mourao, A.M.A., and Alves, T. da C.L. (2007). "Medium-Term Planning: Contributions Based on Field Application", *Proc.*

- 15<sup>th</sup> Ann. Conf. Int'l. Group for Lean Constr., IGLC 15*, 18-20 July, East Lansing, Michigan, pp. 509-518.
- Kitano, M. (1997) "Toyota Production System 'One-by-One Confirmation'," *Lean Manufacturing Conference*, keynote address, University of Kentucky, May-14-16, <http://www.mfgeng.com/images/toyota.pdf>
- Ko, C.H. and Ballard, G. (2004). "Demand Variability and Fabrication Lead Time: Descriptive Research, Phase I." Technical Report, University of California at Berkeley, Berkeley, CA.
- Koskela, L. (1992). *Application of the New Production Philosophy to Construction*. Stanford University, CIFE technical report #72, 87 pp.
- Koskela, L. (2000). An exploration towards a production theory and its application construction. PhD Thesis, University of Technology, Espoo-Finland.
- Koskela, L. (2004). "Making-Do - The Eighth Category of Waste", Proceedings of the 12th International Group for Lean Construction Conference, Denmark.
- Koys, D. J. and Decotiis, T.A. (1991) "Inductive Measures of Psychological Climate", *Human Relations*, Vol. 44, No. 3, pp. 265-285.
- Laseter, T. and Oliver, K. (2003). "When Will Supply Chain Management Grow Up?", *Strategy + Business*, Issue 32, Fall 2003: <http://www.strategy-business.com/media/file/03304.pdf>
- Lee, S., Diekmann, J.E., Songer, A.D., and Brown, H. (1999). "Identifying Waste: Applications of Construction Process Analysis." *Proceedings of the 7th International Group for Lean Construction Conference*, Berkeley, CA, USA.
- Lichtig, W.A. (2006). "The Integrated Agreement for Lean Project Delivery", *Construction Lawyer*, No. 3, Vol. 26, 8 pp.
- Liker, J.K. (2004). *The Toyota Way- 14 Management Principles from the World's Greatest Manufacturer*, McGraw Hill, NY, 330 pp.
- Liu, M., and Ballard, G. (2008). "Improving Labor Productivity Through Production Control", *Proc. 16<sup>th</sup> Ann. Conf. Int'l. Group for Lean Constr., IGLC 16*, 16-18 July, Manchester, UK.

- London, K.A., and Kenley, R. (2001). "An Industrial Organization Economic supply chain approach for the construction industry: a Review", *Construction Management and Economics*, 19, pp. 777-788.
- Lore, N. (1998). *The Pathfinder: How to Choose or Change Your Career for a Lifetime of Satisfaction and Success*, Simon & Shuster Adult Publishing Group, 400pp.
- Macomber, H., and Howell, G. (2003). "Foundations of Lean Construction: Linguistic Action". *Proceedings of the 11<sup>th</sup> annual conference of the International Group for Lean Construction*, Blacksburg, VA.
- Macomber H. (2004). "Securing Reliable Promises on Projects: A Guide to Developing A New Practice", [http://halmacomber.com/MSRP/reliable\\_promises.pdf](http://halmacomber.com/MSRP/reliable_promises.pdf), accessed April 2009.
- Martinez, J.C. (1996). *STROBOSCOPE: State and Resource Based Simulation of Construction Processes*. Ph.D. Dissertation, Department of Civil and Environmental Engineering, University of Michigan, Ann Arbor, MI, 518 pp.
- Martinez, J.C. (2001). "EZSTROBE- General Purpose Simulation System Based on Activity Cycle Diagrams", *Proceedings of the 2001 Winter Simulation Conference*, p. 1556-1564.
- Mauch, J.E., and Park, N. (2003). *Guide to the Successful Thesis and Dissertation- A Handbook for Students and Faculty*, fifth edition, Marcel Drekker, Inc., NY, 330 pp.
- McConnel, S. (2008). "Software Development's Cone of Uncertainty", *Best Practices White Paper*, Construx Software Builders Inc., WA, pp. 8.
- Meredith, J. (1998) "Building Operations Management Theory through Case and Field Research." *Journal of Operations Management*, 16, pp. 441-454.
- Metcalf, L. (2004). "Supply Chains- An Introduction", *Chartered Accountant Journal*, May, pp. 55-57.
- Miles, R. E., and Snow, C.C. (2007). "Organization Theory and Supply Chain Management: An Evolving Research Perspective," *Journal of Operations Management*, 25, pp. 459-463.
- Nahmias, S. (2009) *Production and Operations Analysis*. 6<sup>th</sup> edition, McGraw Hill/Irwin, NY, 789 pp.

- Ohno, T. (1988). *Toyota Production System- Beyond Large-Scale Production*. Productivity Press, Cambridge, MA. 143 pp.
- OSHPD (Office of Statewide Health Planning and Development) (2008). "Phased Plan Review", Facilities Development Division, White Paper, 13pp.
- Riley, D.R., and Tommelein, I.D. (1996). "Space planning tools for multi-story construction", *Computing in Civil Engineering*, New York, pp. 718-724.
- Rother, M., and Shook, J. (1998) *Learning to See: Value Stream Mapping to Add Value and Eliminate MUDA*, Lean Enterprise Institute, Brookline, MA, 96 pp.
- Senior, B.A. (2007). "Implications of Action Theories to Lean Construction Applications", *Proceedings of the 15<sup>th</sup> Annual Conference of the International Group for Lean Construction, IGLC 15*, 18-20 July, East Lansing, Michigan, USA, pp. 407-416.
- Serpell, A., Venturi, A., and Contreras, J. (1995). "Characterization of waste in building construction projects." *Proceedings of the 3rd Annual Conference of the International Group for Lean Construction*, Albuquerque, N.M.
- Shingo, S. (1981). Study of 'Toyota' Production System from Industrial Engineering Viewpoint. Japan Management Association, Tokyo, Japan, 363 pp.
- Shingo, S. (1988). Non- Stock production: The Shingo System for continuous improvement. Productivity Press, Cambridge, MA, 454 pp.
- Shook, J. (2008). *Managing to Learn: Using the A3 Management Process to Solve Problems, Gain Agreement, Mentor, and Lead*. Lean Enterprise Institute, 138 pp.
- Simchi-Levi D., Kaminsky P., and Simchi-Levi E. (2003). *Designing and Managing the Supply Chain*, second edition, McGraw-Hill Irwin, 354 pp.
- Smith, S.F. (2003). "Is Scheduling a Solved Problem?", *Proceedings of the First Multi-Disciplinary International Conference on Scheduling: Theory and Applications (MISTA 03)*, August, Nottingham, UK, 16 pp.
- Stuart, I., McCutcheon, D., Handfield, R., McLachlin, R., Samson, D. (2002) "Effective Case Research in Operations Management: A Process Perspective." *Journal of Operations Management*, 20, pp. 419-433.
- Suchman, L.A. (1987). *Plans and Situated Actions: The Problem of Human-Machine Communication*, Cambridge, UK: Cambridge University Press.

- The Last Planner Handbook at CHH project (2009) IPD team at CHH project, Version 2.0, San Francisco, CA, 14pp.
- Thomas, H. R., Horman, J. H., Minchin R. E., and Chen, D. (2003). "Improving Labor Flow Reliability for Better Productivity as Lean Construction Principle," *Journal of Construction Engineering and Management*, ASCE, May/June, pp. 251-261.
- Thomas, H. R., Horman, J. H., Minchin R. E., and Souza, U.E.L. (2004). "Symbiotic Crew Relationships and Labor Flow," *Journal of Construction Engineering and Management*, ASCE, Nov. /Dec., pp. 908-917.
- Thompson, J.D. (1967). *Organizations in Action*. McGraw-Hill, New York.
- Tommelein, I.D. (1998). "Pull-driven Scheduling for Pipe-spool installation: Simulation of a Lean Construction Technique". *Journal of Construction Engineering and Management*, ASCE, July/Aug., pp. 279-288.
- Tommelein, I.D. (2003). "Acknowledging Variability and Uncertainty in Product and Process Development." Chapter in Issa, R.R.A., Flood, I., and O'Brien, W.J. (editors) *4D CAD and Visualization in Construction: Developments and Applications*, A.A. Balkema Publishers, pp. 165-193.
- Tommelein, I.D. (2004). *The Value Chain: Adding Value to the Supply Chain*, Mechanical Contracting Education & Research Foundation (MCERF), Chantilly, VA.
- Tommelein, I.D. and Ballard, G. (1997). "Look-ahead Planning: Screening and Pulling." *Technical Report No. 97-9*, Construction Engineering and Management Program, Civil and Environmental Engineering Department, University of California, Berkeley, CA, USA.
- Tommelein, I.D., Ballard, G., and Kaminsky, P. (2009). "Supply Chain Management for Lean Project Delivery." Chapter 6 in O'Brien, W.J., Formoso, C.T., Vrijhoef, R., and London, K.A. (eds.) *Construction Supply Chain Management Handbook*. CRC Press, Taylor & Francis Group, Boca Raton, FL.
- Tommelein, I.D., Riley, D.R., and Howell, G.A. (1999). "Parade Game: Impact of Work Flow Variability on Trade Performance." *Journal of Construction Engineering and Management*, ASCE, Sep. /Oct., pp. 304-310.

- Tommelein, I.D., Walsh, K.D., and Hershauer, J.C. (2003). "Improving Capital Projects Supply Chain Performance." *Research Report PT172-11*, Construction Industry Institute, Austin, TX, 241 pp.
- Tommelein, I.D., and Weissenberger, M. (1999). "More Just-In-Time: Location of Buffers in Structural Steel Supply and Construction Processes," *Proceedings of the 7th International Group for Lean Construction Conference*, Berkeley, CA, USA.
- Tsao, C.C.Y., Tommelein, I.D., Swanlund, E.S., and Howell, G.A. (2004). "Work Structuring to Achieve Integrated Product-Process Design", *Journal of Construction Engineering and Management*, 130(6), pp. 780-789.
- Validation Study Report (2007). Integrated Project Delivery Team, Cathedral Hill Hospital Project , 16 July, San Francisco, CA, 790 pp.
- Vrijhoef, R., Koskela, L. (1999). "Roles of Supply Chain Management in Construction", *Proceedings of the Seventh Annual Conference of the International Group for Lean Construction IGLC-7 Berkeley*, July 26-28, pp. 133-146.
- Vrijhoef, R., Koskela, L. (2000). "The Four Roles of Supply Chain Management in Construction", *European Journal of Purchasing & Supply Management*,(6), pp. 169-178.
- Womack, J.P. (2006). "Mura, Muri, Muda? *Jim Womack E-letter*", 07 July, [http://www.leanuk.org/articles/mura\\_muri\\_muda.pdf](http://www.leanuk.org/articles/mura_muri_muda.pdf), last accessed November 12, 2007.
- Womack, J.P., and Jones, D.T. (2003) *Lean Thinking: Banish Waste and Create Wealth in Your Corporation*, Simon & Schuster, New York, 396 pp.
- Womack, J.P., Jones, D.T., and Roos, D. (1990). *The Machine that Changed the World*. Harper-Collins, NY, 323 pp.
- Yin, R.K. (2003). *Case Study Research- Design and Methods*, third edition, Sage Publications, Thousand Oaks, CA ,181 pp.
- Zammuto, R.F. and Krakower, J.Y. (1991) "Quantitative and Qualitative Studies in Organizational culture", *Research in Organizational Change and Development*, Vol. 5, pp. 83-11.