

# Lawrence Berkeley National Laboratory

## Recent Work

### **Title**

Summary of the Working Group 4: Hadron Spectroscopy

### **Permalink**

<https://escholarship.org/uc/item/1x3327qr>

### **Author**

Crowe, K.M.

### **Publication Date**

1991-03-01



# Lawrence Berkeley Laboratory

UNIVERSITY OF CALIFORNIA

Presented at the Workshop on Science at the KAON Factory,  
Vancouver, BC, Canada, July 23-28 1990,  
and to be published in the Proceedings

## Summary of the Working Group 4: Hadron Spectroscopy

K.M. Crowe

March 1991

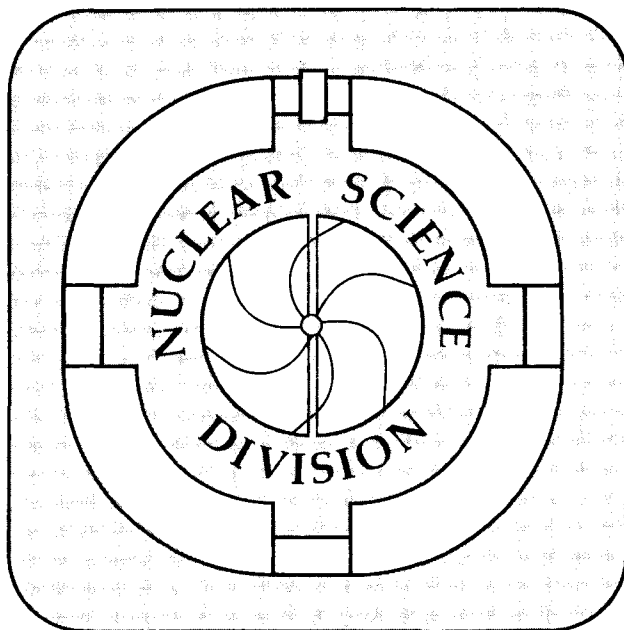

1 LOAN COPY 1  
1 Circulates 1  
1 for 4 weeks 1 Bldg. 50 Library.  
Copy 2

LBL-30494

#### DISCLAIMER

This document was prepared as an account of work sponsored by the United States Government. Neither the United States Government nor any agency thereof, nor The Regents of the University of California, nor any of their employees, makes any warranty, express or implied, or assumes any legal liability or responsibility for the accuracy, completeness, or usefulness of any information, apparatus, product, or process disclosed, or represents that its use would not infringe privately owned rights. Reference herein to any specific commercial product, process, or service by its trade name, trademark, manufacturer, or otherwise, does not necessarily constitute or imply its endorsement, recommendation, or favoring by the United States Government or any agency thereof, or The Regents of the University of California. The views and opinions of authors expressed herein do not necessarily state or reflect those of the United States Government or any agency thereof or The Regents of the University of California and shall not be used for advertising or product endorsement purposes.

Lawrence Berkeley Laboratory is an equal opportunity employer.

## **DISCLAIMER**

This document was prepared as an account of work sponsored by the United States Government. While this document is believed to contain correct information, neither the United States Government nor any agency thereof, nor the Regents of the University of California, nor any of their employees, makes any warranty, express or implied, or assumes any legal responsibility for the accuracy, completeness, or usefulness of any information, apparatus, product, or process disclosed, or represents that its use would not infringe privately owned rights. Reference herein to any specific commercial product, process, or service by its trade name, trademark, manufacturer, or otherwise, does not necessarily constitute or imply its endorsement, recommendation, or favoring by the United States Government or any agency thereof, or the Regents of the University of California. The views and opinions of authors expressed herein do not necessarily state or reflect those of the United States Government or any agency thereof or the Regents of the University of California.

LBL-30494

**SUMMARY OF THE WORKING GROUP 4:**

**HADRON SPECTROSCOPY**

Kenneth M. Crowe

Lawrence Berkeley Laboratory  
University of California, Berkeley  
Berkeley, California 94720

March 1991

This work was supported by the Director, Office of Energy Research, Division of Nuclear Physics of the Office of High Energy and Nuclear Physics of the U.S. Department of Energy under Contract DE-FG03-87ER40323.

This report has been reproduced directly from the best available copy.

## SUMMARY OF THE WORKING GROUP 4: HADRON SPECTROSCOPY

K.M. Crowe

Lawrence Berkeley Laboratory, Berkeley, CA 94720, U.S.A.

### A. Physics motivation:

1. Conventional mesons and baryons
2. Multiquark mesons
3. Glueballs
4. Hybrids

### B. Design of spectrometer:

1. Technology
2. Tools
3. Triggers
4. Software
5. Monte Carlo
6. Data presentation
7. Amplitude analysis

### C. Status of some existing hadron spectrometers:

1. LASS (Stanford)  $4\pi$  uniform acceptance
2. MPS (Brookhaven) dipole spectrometer and detector triggers
3. Crystal Barrel (CERN-LEAR)

### D. Improvements to LASS:

1. Better resolution of drift chambers ( $600 \mu\text{m} \rightarrow 100 \mu\text{m}$ )
2. Higher momentum beams ( $K^\pm, \pi^\pm, \bar{p}$  at 6-20 GeV/c)
3. Larger data sample ( $50 \times 10^8$  events)
4. Better particle identification (TOF resolution of approximately 100 ps)
5. Addition of neutral detectors [Crystal barrel for backward  $\gamma$ 's, CsI (Tl) or lead glass for forward  $\gamma$ 's (or pure CsI or CsF)]

E. Arguments for/against a LASS-like design:

- + 1. Performance already demonstrated
- + 2. Major improvements predicted
- + 3. Real data (11 GeV/c) can be used to simulate KAON, check Monte Carlo, and test on/off-line software
- + 4. "Interaction" trigger and "enhancement" of  $X > 100$ , minimum bias, rare events - TAGS
  
- + 5. Scaling from  $10^8$  to  $10^{10}$  events is feasible
- 6. 5 - 10 year program until final results
- + 7. No comprehensive program elsewhere

F. Progress to date, plans and needs:

Work ahead for preliminary design and preliminary letter of intent.

## INTRODUCTION

The working group on the Hadron Spectrometer has been active since February 20-21, 1989, when a conference organized by Steve Godfrey and Martin Comyn was held at TRIUMF. The physics issues were presented by F. Close, S. Godfrey and N. Isgur. The experimental facilities discussion was centered around a multi-user hadron facility which would require a spectrometer with many of the features of the Large Aperture Superconducting Solenoid (LASS) at SLAC, the Multi-Particle Spectrometer (MPS) at Brookhaven, the Crystal Barrel at LEAR and the Canadian High Acceptance Orbit Spectrometer (CHAOS) being designed and built at TRIUMF. This multi-user facility would operate with separated pion and kaon beams from 10 - 20 GeV/c, and  $\bar{p}$  beams up to the maximum available energy, the beams being of the highest quality.

In the workshop this week, a series of talks reviewed the theoretical and experimental status of hadron spectroscopy and included a variety of new suggestions, results and proposed experiments. The  $q\bar{q}$  states given by SU(3), glueballs, hybrid and multiquark mesons, the H, Pentaquark and Tetraquark, missing scalar mesons, status of the AX(1565), interference correlations and threshold effects form a shortened list of the contributions.

A roughly equal number of talks were presented having to do with the tools of spectrometer design, Monte Carlo studies, on-line and off-line software problems, data presentation, amplitude analysis, and  $dE/dx$ , time-of-flight, etc. in detectors. Again in the discussions, the emphasis was on improvements to implement in the next five to ten years and the enumeration of the problems to be solved in handling data samples of  $10^{10}$  events with minimum biases, well-understood particle identification and selection criteria. There



were many discussions, conflicting opinions and unanswered questions.

In this summary of the workshop, I will limit myself to reporting the contributions and conclusions on topics which emerged as the consensus as to what the spectrometer program should accomplish, what main improvements can be expected in the upgrades to high acceptance, good resolution detectors which we think are necessary and feasible for the next generation of hadron spectroscopy at KAON.

#### **A. PHYSICS MOTIVATION**

The QCD theory of strong interactions has yet to produce an understanding of physical states to compare with observations. The conventional  $q\bar{q}$  states are shown in Fig. 1. In our session, Claude Amsler's talk gave an up-to-date review of the established, uncertain and missing states. The states which do not fit the SU(3)  $q\bar{q}$  classification scheme are candidates for glueballs, hybrids or multiquark mesons. Above a mass of 1.7 GeV, there are many missing states yet to be identified. In his final transparency, Fig. 2, he summarized the situation, together with his recommendations for the KAON spectroscopy program.

Introduction :  $q\bar{q}$  mesons

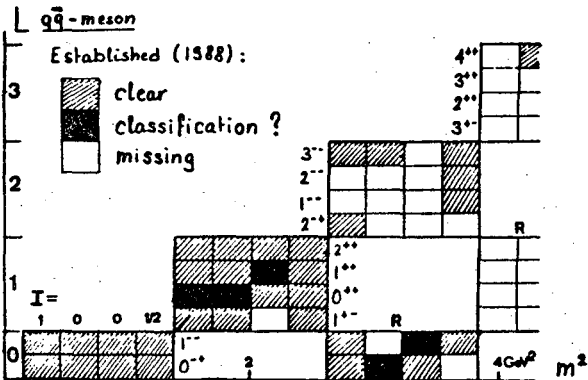
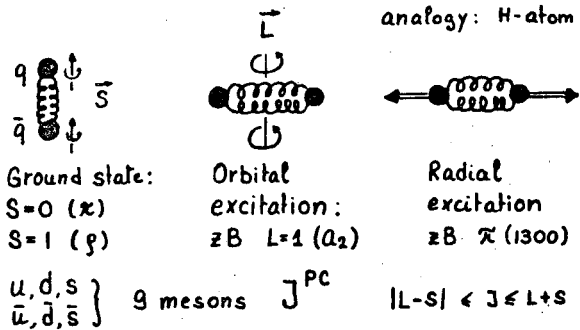

Many missing states  $m \geq 1.7$  GeV

Figure 1: Conventional  $q\bar{q}$  states.

CONCLUSIONS

- Too many candidates in  $SU(3)$   $q\bar{q}$  scheme
  - 4-quark:  $A\chi$
  - molecule:  $a_0, f_0, f_1(1420)$
  - glueballs:  $\eta(1430), f_2(1720), f_0(1530)$  } ?
  - no hybrid yet
- Missing  $q\bar{q}$   $m \geq 1.7$  GeV  
 Identify them!  $\rightarrow$  excess states
- All decay modes ( $\pi\pi, K\bar{K}\pi, \eta\eta, \eta\eta', \eta\pi\pi, \omega\omega\dots$ )  
 promising exp. approach  
 CB, GAMS

- Several approaches:  
 $\pi p, pp, K^+p, \chi\chi, J/\psi, \bar{p}p \dots$   $m_x$  up to PS limit!
- KAON : high fluxes  
 $\sqrt{s} = 3.2$  GeV
- LEAR :  $\sqrt{s} < 2.4$  GeV  
 Broad states ( $m > 1.7$  GeV)  
 be observed at LEAR  
 (Phase space limitation).

Figure 2: Summary of present situation.

### C. STATUS OF SOME EXISTING HADRON SPECTROMETERS

In his talk, "A summary of the results from LASS and the future of strange quark spectroscopy," Bill Dunwoodie presented an impressive review of the spectroscopy done at SLAC, describing experiment E-135. The detector, shown in Fig. 3, consists of a solenoidal magnet, followed by a dipole magnet with Cerenkov counters, proportional chambers, scintillation counters, hodoscopes and magnetostrictive chambers. The resolution of the spectrometer is given in Fig. 4, with the wedges representing the dipole component and the contour map representing the solenoidal resolution for the longitudinal and transverse components of momenta. The acceptance is sufficiently large to cover almost the entire phase space, in, for example, the  $K^-p \rightarrow \pi^+ \Sigma^-$  reaction. The results for  $K^-p \rightarrow K^- \pi^+ \eta$  can be seen in Figs. 5 and 6. The top figure shows the final  $K^-$  momentum distribution; the longitudinal momentum  $P_L$  and transverse momentum  $P_T$  are displayed on the horizontal and vertical axes, respectively. One sees the forward-produced  $K^-$  coming from  $K^*$  decay as an intense blob. Also, one sees the non-resonant products distributed throughout the momentum plots. The bottom figure shows the  $\pi^+$  momentum distribution, with the  $\pi^+$  strongly peaked in the opposite direction, i.e. travelling backwards in the  $K^*$  frame. Note the structure in the distribution corresponding to  $n^*$  enhancement of the  $\pi^- n$  final state.

Fig. 7 is the color histogram of the protons from  $K^-p \rightarrow K^0 \pi^- p$ . Here the  $K^*$  bands show clearly, the strongest being  $K^+(890)$ ; the 1430 and 1750 also stand out clearly. Fig. 8 shows the Dalitz plot  $m_{K\pi}^2$  vs  $m_{p\pi}^2$  for this reaction. The  $\Delta(1236)$ ,  $N^*(1512)$  and  $N^*(1700)$  are vertical lines on the left. The  $K^*(890)$ ,  $K^*(1730)$  and  $K^*(1780)$  appear as horizontal bands. The  $\gamma^*$  ( $\sim 1700$ ) appears faintly near the diagonal edge. In this figure,

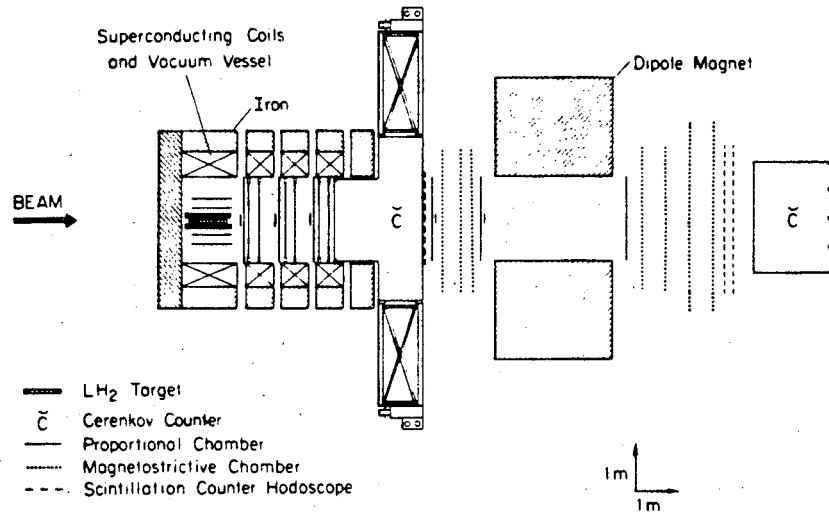

Figure 3: Plan view of the LASS Spectrometer.

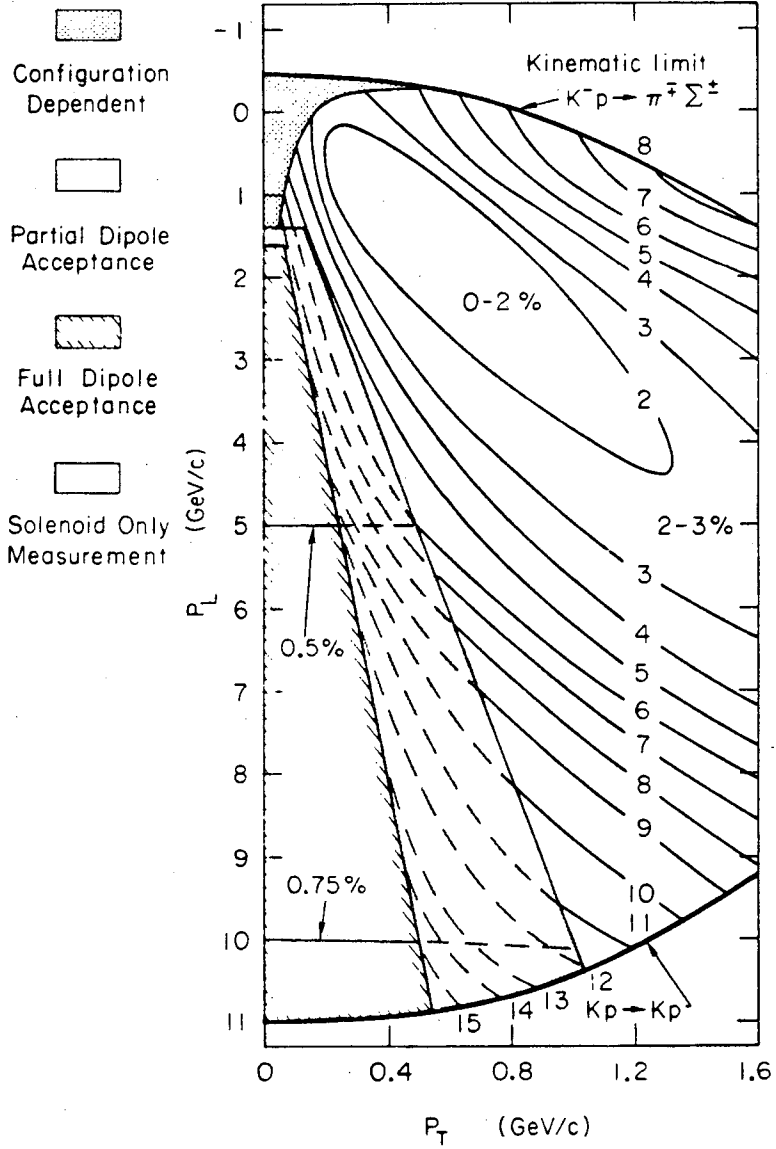

Figure 4: The momentum resolution for the full LASS spectrometer within the kinematically allowed region for  $Kp$  interactions at 11 GeV/c.

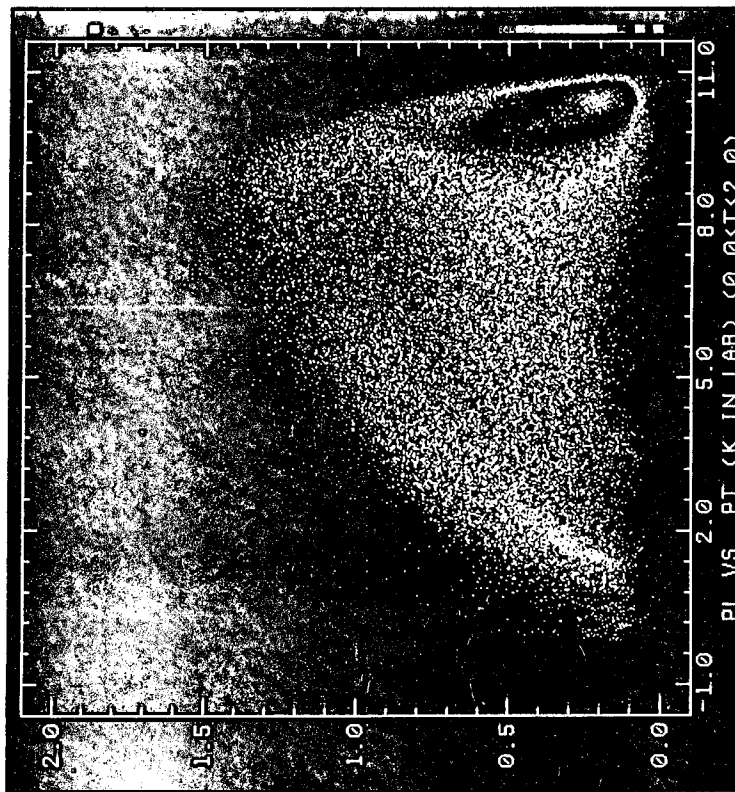

Figure 5:  $p_L$  vs  $p_T$  for  $K^- p \rightarrow K^- \pi^+ \eta$ .

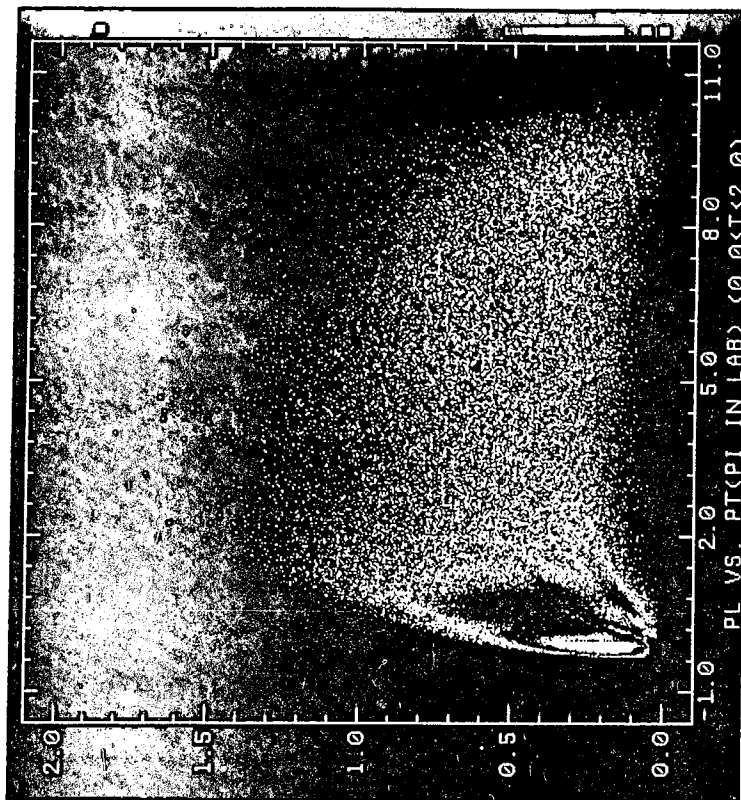

Figure 6:  $p_L$  vs  $p_T$  for  $K^- \pi^+ \rightarrow K^- \pi^+ \eta$ .

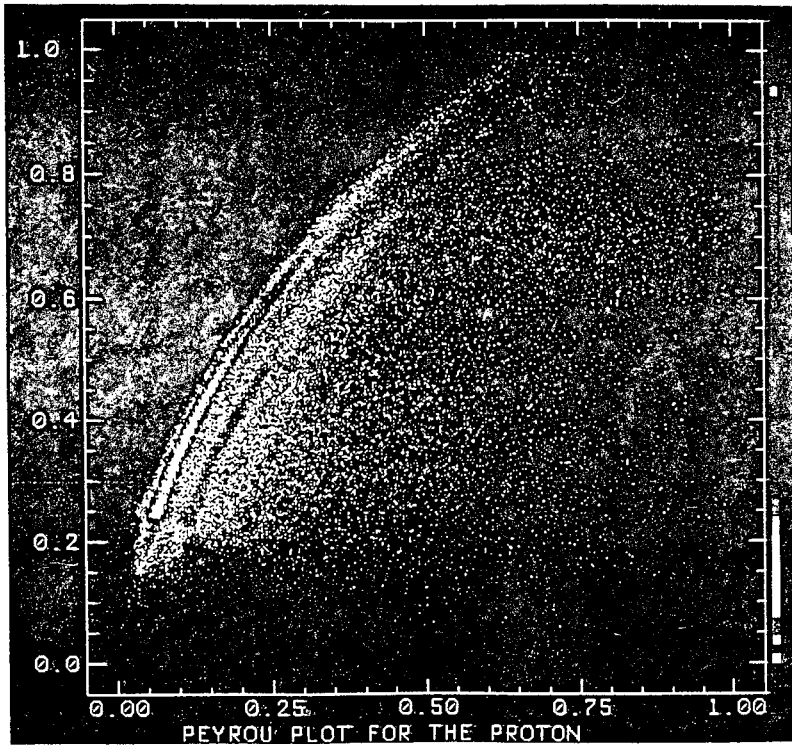

Figure 7:  $p_L$  vs  $p_T$  for protons from  $K^-p \rightarrow \bar{K}^0\pi^-p$ .

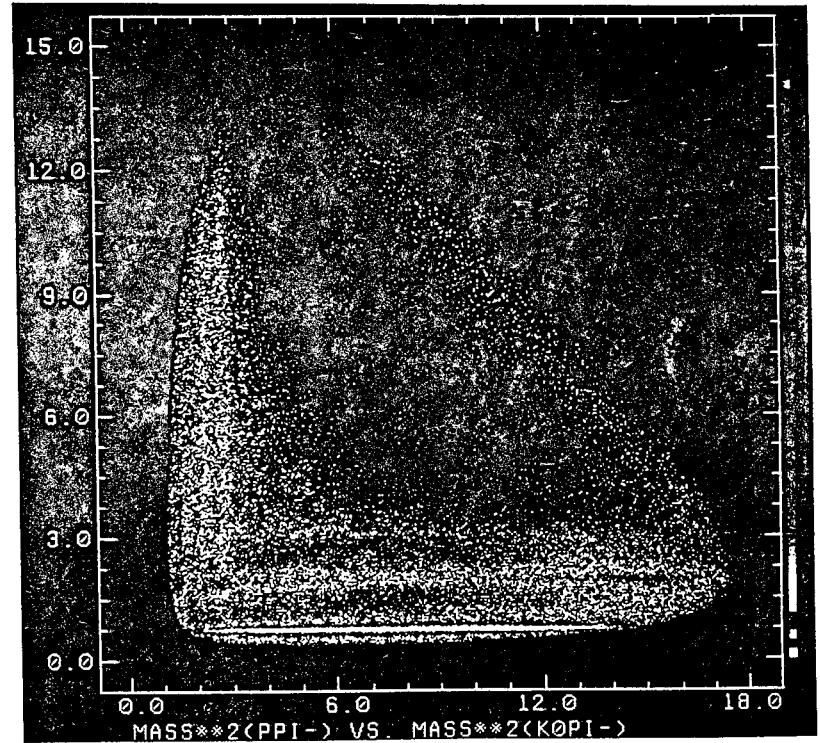

Figure 8: Dalitz plot of  $m_{\bar{K}^0\pi^-}^2$  vs  $m_{p\pi^-}^2$  from  $K^-p \rightarrow \bar{K}^0\pi^-p$ .

~92,000 events are shown. Low energy protons (~5000) stop in the target.

In his talk, Dunwoodie discussed the observation of  $\Omega^*$ ,  $\Xi^{*0} K^-$ ,  $\Omega^- \pi^+ \pi^-$  and inclusive  $\Xi^-$  analysis. He reviewed the  $\bar{K}^0 \pi^+ \pi^- n$ , and  $K \eta p$  reactions, in addition to the  $K^- \pi^+ n$ , and  $K^0 \pi^+ p$  reactions shown above. For the  $s\bar{s}$  mesons, the  $K_s^0$ ,  $K_s^0 \Lambda$ ,  $K^- K^+ \Lambda$  and  $K_s^0 K^\pm K^\mp \Lambda$  channels were analyzed. He summarized the requirements for the continuation of this program as follows:

1. High-intensity, R.F.-separated beam in order to acquire data in a short period (3-6 months); need  $\geq 10^5$  K's/sec on a 10 cm target
  - ~500 evts/sec
  - 5 Mbytes/sec data transfer rate.
2. Upgraded LASS-type detector with better resolution,  $\gamma$ -detection, a silicon pixel vertex detector, etc.
3. It should be a major part of the lab program - it involves significant, long-term commitment.
4. There should be strong in-house involvement for purposes of continuity and support; an active, enthusiastic user group; self-criticism, experience, etc. at the analysis stage; and constructive theoretical interest in-house.
5. Lots of computer power: powerful mainframes plus a microprocessor farm, extensive data storage and retrieval capability, plus a network of user-friendly, low-end workstations.

A meson-baryon spectroscopy facility should play a prominent role in the physics program of KAON.



The principal goals should be to:

- a. Extend and improve upon the work of LASS in the strange meson sector
- b. Bring the understanding of the  $\bar{s}s$  sector to a comparable level
- c. Produce results of similar quality and scope in the non-strange sectors by using incident  $\pi^-$ 's;
- d. Provide detailed information in the area of baryon spectroscopy, especially to complement the results of formation experiments at lower incident momenta.

S.U. Chung gave a description of the quark-gluon spectroscopy program at Brookhaven National Laboratory. The MPS shown in Fig. 9 is built around a 6-m long, 3-m wide, 1.2-m gap dipole magnet with a 0.5 Tesla field. Chung detailed four parts of the program: E-771  $E/\text{iota}(1460) \rightarrow K\bar{K}\pi$  and  $p$  at 6.6 - 8.0 GeV/c (1983-1987); E-818  $J^{PC} = 1^{-+}$ ,  $\pi^- f_1(1285)$  (1989-1990),  $\pi^- p$  at 18 GeV/c; E-852 "Lead glass and CsI at the MPS," ( $M^{\circ}(1405) \rightarrow \pi^{\circ}\eta$  (1990-1993); and the Relativistic Heavy Ion Collider (RHIC) and detector plans of the future (1991-1996).

Fig. 10 shows the possible decay modes for the  $M^{\circ}(1405)$ . Notice the number of states which require both charged and neutral detection. As the mass increases, the number of decay channels increases. For example, if a neutral hybrid  $X^{\circ}(1900) I^G(J^{PC}) = 1^-(1^{-+})$  decays into  $\pi^{\circ} f_1(1285) \rightarrow \pi^{\mp} a_0^{\pm} \rightarrow K^{\pm} K^{\circ} \rightarrow \pi^+ \pi^-$ , there are 4 charged particles and one  $\pi^{\circ}$  (= 2  $\gamma$ 's). On the other hand, if it decays as  $\pi^{\pm} b_1^{\mp}(1235) \rightarrow \pi^{\mp} \omega \rightarrow \pi^{\circ} \gamma$ , 2 charged particles and 3  $\gamma$ 's must be detected.

The simultaneous observation of several charged particles and several gammas will

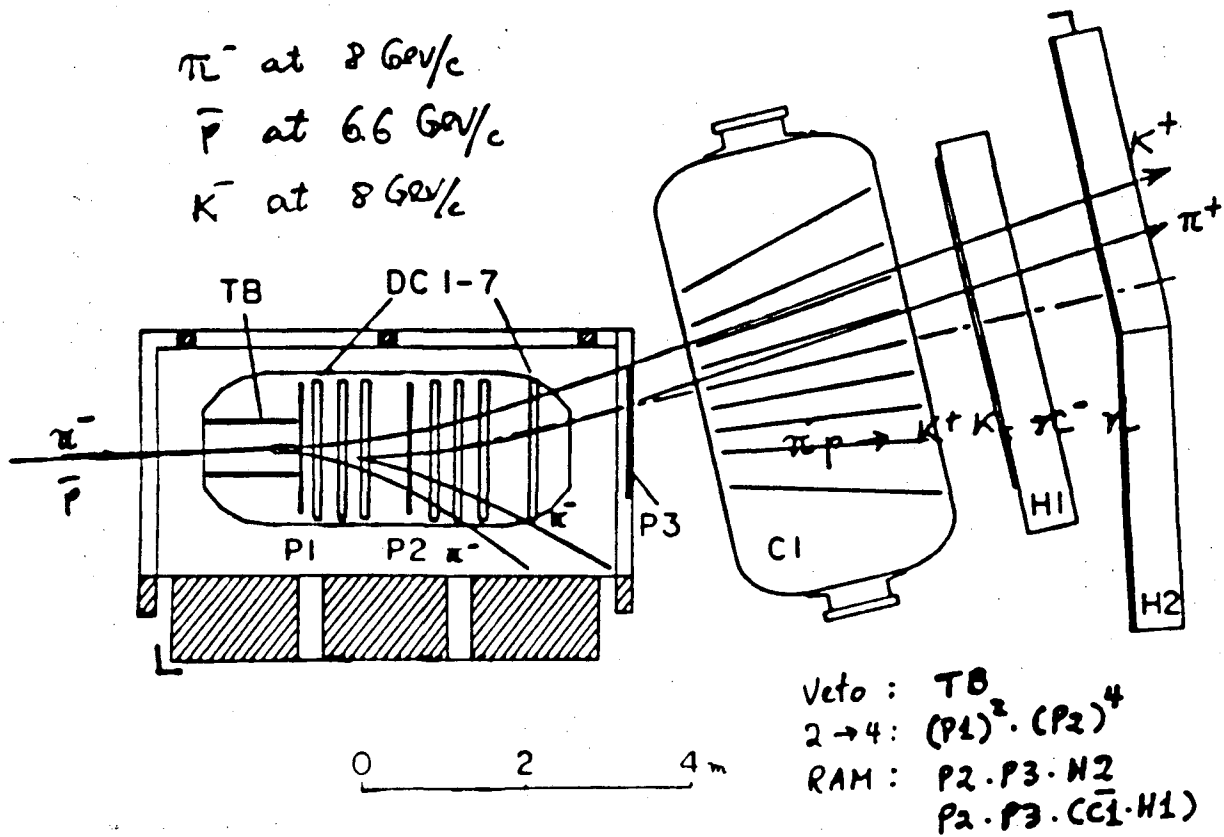

Figure 9: Plan view of the MPS Spectrometer.

## $M^0(1405)$ Decay Modes

Mode	Intermediate	Final	BR %	GAMS	E852
$\eta\pi^0$	$\eta \rightarrow 2\gamma$	$4\gamma$	40	YES	YES
$\eta\pi^0$	$\eta \rightarrow \pi^+\pi^-\pi^0$	$\pi^+\pi^-4\gamma$	24	NO	YES
$\eta'\pi^0$	$\eta' \rightarrow 2\gamma$	$4\gamma$	2	YES	YES
$\eta'\pi^0$	$\eta' \rightarrow \eta\pi^0\pi^0$	$8\gamma$	8	YES	YES
$\eta'\pi^0$	$\eta' \rightarrow \eta\pi^+\pi^-$	$\pi^+\pi^-4\gamma$	11	NO	YES
$\eta'\pi^0$	$\eta' \rightarrow \rho^0\gamma$	$\pi^+\pi^-3\gamma$	30	NO	YES
$(b_1(1235)\pi)^0$	$b^{\pm} \rightarrow \omega\pi^{\pm}$	$\pi^+\pi^-3\gamma$	9	NO	YES

Figure 10: Possible decay modes for the  $M^0(1405)$ .

rapidly become more important as the number of decay channels increases with the increase in mass of the resonance states. Wider, partially overlapping states require high acceptance, good resolution and large statistics for the amplitude analysis, if one is to untangle the puzzles.

Curtis Meyer presented a brief description of the Crystal Barrel detector now in use at CERN-LEAR. The  $\gamma$  detector consists of 1380 CsI crystals covering 95 percent of the  $4\pi$  solid angle, combined with the Jet Drift Chamber in a 1.5 Tesla magnetic field covering approximately 93 percent of  $4\pi$ , has collected  $> 10^7$  events from stopping  $\bar{p}$ 's in hydrogen in various modes of operation. Meyer showed typical events and an example of the preliminary analysis of two channels,  $4\gamma\pi^+\pi^-$  and  $6\gamma$  states.

Fig. 11 shows the detector: the CsI Barrel, the Jet Drift Chamber, the proportional chamber, and at the center, the liquid hydrogen target in which the  $\bar{p}$  beam stops in the initial experiments. The tables give the essential information on the calorimeter and the Jet Drift Chamber. The energy resolution for the barrel calorimeter is approximately 3% at 1 GeV and varies as  $(E\gamma)^{-1/4}$ . The JDC transverse momentum resolution at 200 MeV/c is approximately 2%, increasing approximately linearly with momentum.

The importance of high efficiency is shown in Fig. 12. The mass spectrum of  $6\gamma$  events is shown in the top spectrum. The background consists mainly of incorrect combinations of  $\pi^0$ -decay photons. By cutting out all events within the  $\pi^0$  mass window, the insert shows that the peak stands well above the remaining background. By further cutting out  $\eta$  events, the  $\eta'$  peak at 960 MeV appears with an approximately 1:1 signal-to-background ratio. One cannot imagine an upgraded spectrometer that would not have such

a capability in both charged and neutral detection.

An early proposal (Amsler and Crowe) to expand the Crystal Barrel by adding a downstream dipole is shown in Fig. 13. Fig. 14 shows the resolution guesstimated for increasing the field to 3 Tesla.

CsI Calorimeter	
Medium	CsI ( $\approx 0.1$ Mol % Tl)
Inner Radius	270 mm
Active Length	16 Radiation Lengths
Solid Angle	97% of $4\pi$ 95% of $4\pi$ (Exclude Guard Crystals)
Crystals	1380
Crystal Shapes	13
Symmetry	Cylindrical
Segmentation	$6^\circ$ , ( $12^\circ$ near beam axis)
Energy Resolution	$\approx 2.9\% / \sqrt{E(\text{GeV})}$
Spatial Resolution	$\approx 1.2^\circ$ (single $\gamma$ cluster) $\approx 2.7^\circ$ (multi $\gamma$ cluster)

Jet Drift Chamber	
Chamber Length	400 mm
Inner Radius	50 mm
Outer Radius	257 mm
Signal Wires	30 Sectors with 23 Layers (690)
Wire Spacing	8 mm Signal to Signal
Material	$20 \mu\text{m}$ Elgiloy, ( $1200 \Omega$ )
Field Wires	30 Sectors with 77 Wires (2310)
Material	$180 \mu\text{m}$ Gold-plated Aluminum
Gas Mixture	90% $\text{CO}_2$ , 10% Isobutane
Amplification	$\approx 5 \cdot 10^4$
Drift Field	1.1 kV/cm
Drift Velocity	10 mm/ $\mu\text{s}$
Lorentz Angle	$7^\circ$ in the 1.5 T Field
Maximum Drift Time	$\approx 3 \mu\text{s}$
Solid Angle to Layer 3	93% of $4\pi$
Solid Angle to Layer 10	83% of $4\pi$
Spatial Resolution	( $r, \phi$ ) $\approx 125 \mu\text{m}$ ( $z$ ) $\approx 7.5 \text{ mm}$
Double Hit Separation	$\approx 2 \text{ mm}$ in the $r - \phi$ Projection

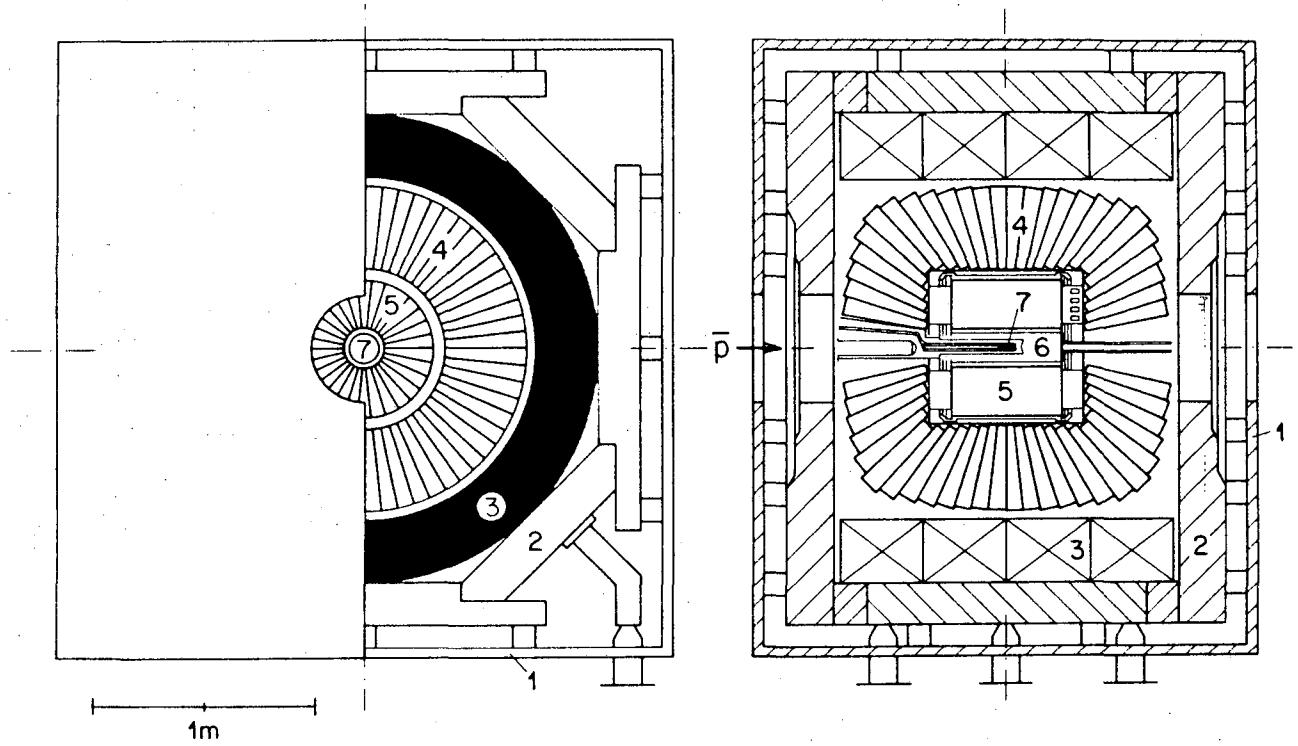

Figure 11: The Crystal Barrel detector. (1,2 - yoke, 3 - coil, 4 - CsI barrel, 5 - JDC, 6 - PWC, 7 - LH<sub>2</sub> target).

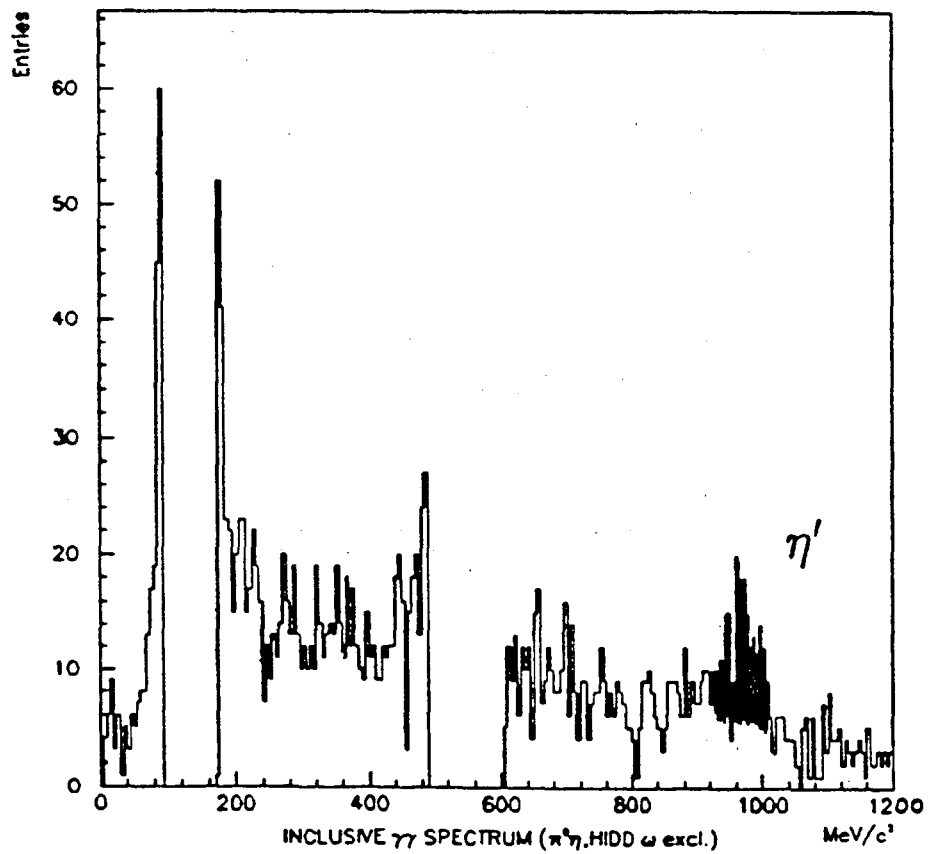
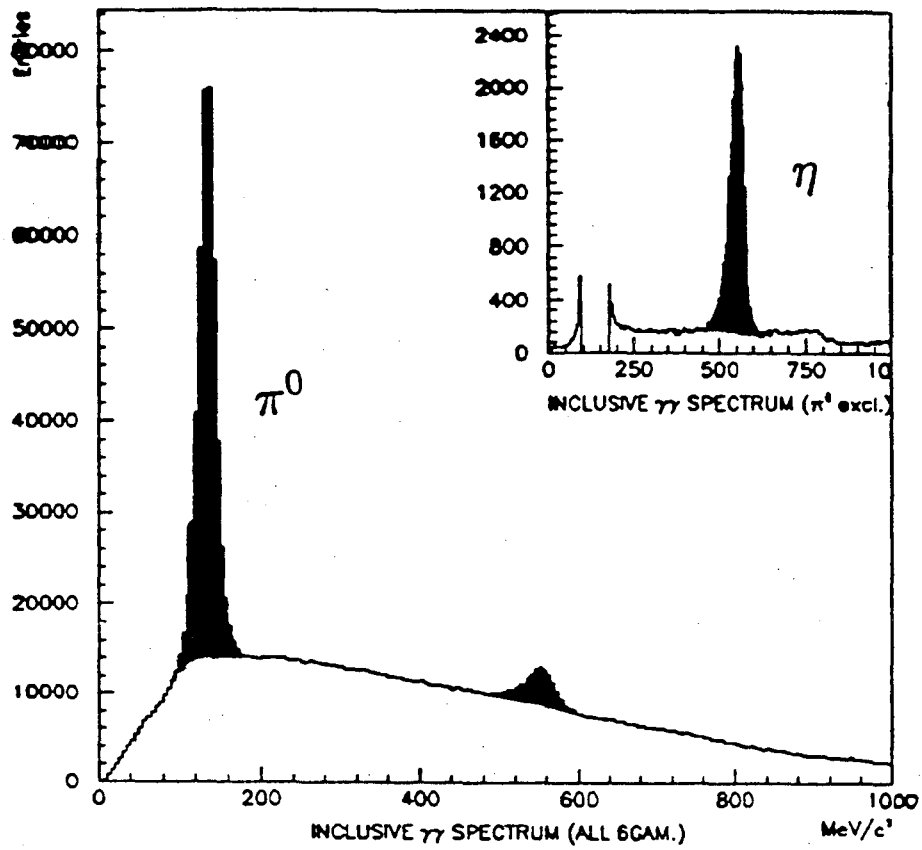

Figure 12: Inclusive  $\gamma\gamma$  invariant mass spectra ( $6\gamma$  final state).

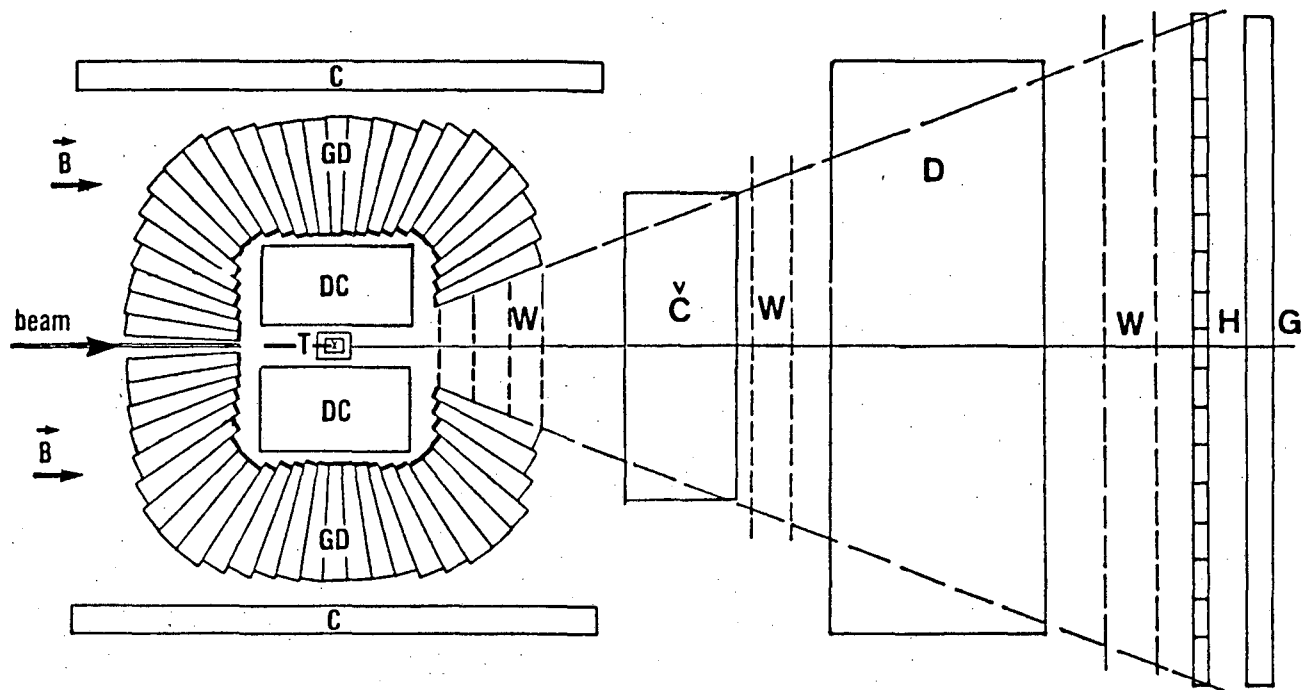

Figure 13:  $\bar{p}p$  or  $K^-p$  facility using the Crystal Barrel. (C – solenoid, DC – jet drift chamber, GD – CsI barrel, T –  $\text{LH}_2$  target, W – PWC, Č – Čerenkov, D – dipole magnet, H – hodoscope, G – lead glass hodoscope or crystal detector).

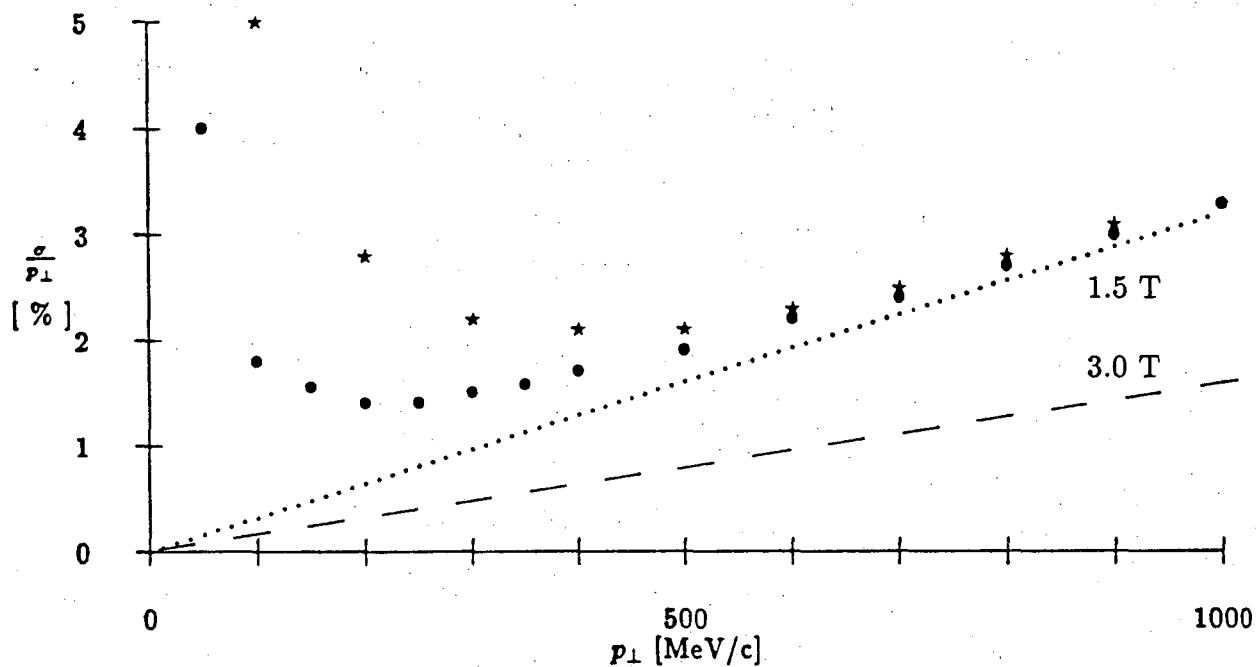

Figure 14: Chamber resolution as a function of transverse momentum,  $p_{\perp}$ . • is for pions and \* is for kaons. The diagonal dashed lines are the resolution limits only from measurement errors, assuming 23 points per track.



#### **D. IMPROVEMENTS TO LASS**

Let us look at the improvements to LASS-which represents today's typical detector performance. The resolution in both the dipole and solenoidal spectrometer can be improved by changing to modern drift chamber technology. The  $600\mu\text{m}$  resolution of ten years ago could now be  $<100\mu\text{m}$ .

To enlarge the areas for studying resonances, one increases the beam momentum from 11 to 20 GeV/c for both signs of  $\pi$ 's and K's, and uses  $\bar{p}$ 's up to the KAON limit of approximately 15 GeV/c. Three of the beam lines are shown in Fig. 15.

The data rates indicate  $100\times$  larger data samples are possible with several months of running. Improvements in time of flight, Cerenkov counters, pixel vertex detection, etc. will sharpen the particle identification. Finally, the addition of neutral detection: placing the Crystal Barrel in the backward zone and a fast  $\gamma$  detector made of lead glass, pure CsI or CsF in the forward zone may be the best combination.

Properties of Separated Beams at KAON

Channel	Momentum GeV/c	Solid Angle msr	Momentum Acceptance $\Delta p/p$ in %	Length m	Type of Separation
K20	20-6	0.1	1	160	RF, 3 cavities, 2.8 GHz
K6	6-2.5	0.08-0.30	3	110	RF, 3 cavities, 1.3 GHz
K2.5	2.5-1.25	0.5-2.0	4	54	DC, 2 stages

Anticipated Beam Intensities<sup>a</sup>

Channel	P GeV/c	K <sup>-</sup> 10 <sup>6</sup> /s	K <sup>+</sup> 10 <sup>6</sup> /s	$\pi^-$ 10 <sup>9</sup> /s	$\pi^+$ 10 <sup>9</sup> /s	$\bar{p}$ 10 <sup>6</sup> /s
K20	21	0.75	29	0.16	0.95	0.05
	18	2.4	43	0.35	1.05	0.35
	15	5.9	62	0.60	1.50	1.7
	12	9.2	52	0.90	1.90	5.0
	9	7.9	23	0.70	1.30	10.5
	6	2.3	4.2	0.78	1.20	11.5
K6	6	15	34	1.9	3.6	23
	3	2.5	4.5	3.2	5.0	43
K2.5	2.5	66	119	16	24	110
	2.0	39	76	21	30	91
	1.5	14	27	25	36	52
	1.25	5.4	9.7	27	37	26

<sup>a</sup>Intensities are for a 100  $\mu$ A 30 GeV beam on a 6 cm Pt target.

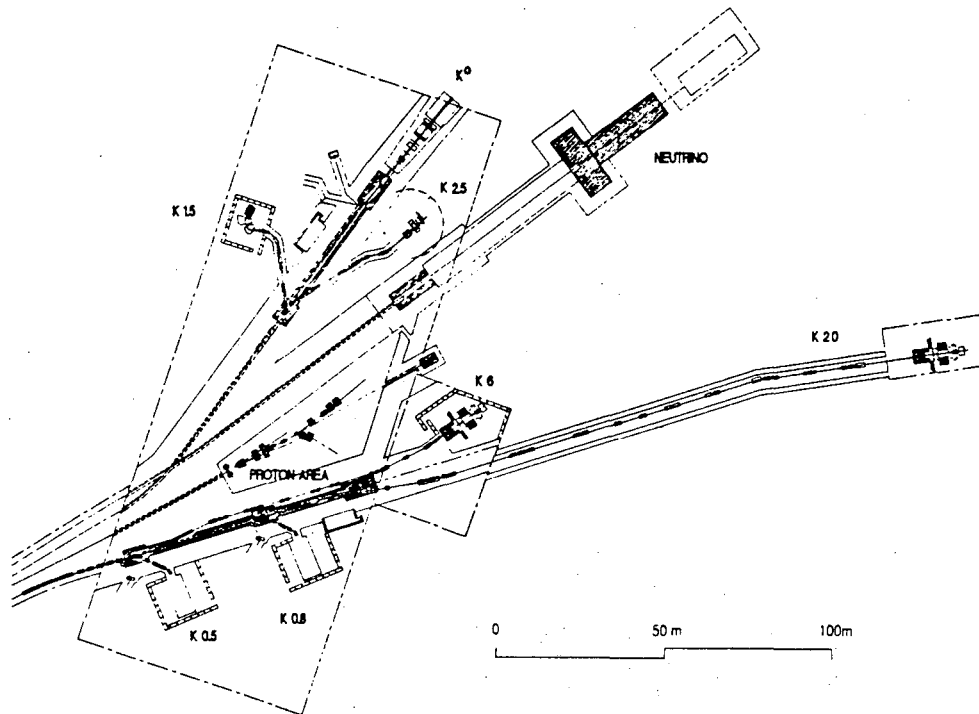

Figure 15: KAON beam lines suitable for hadron spectroscopy.

**E. ARGUMENTS FOR/AGAINST THE LASS-LIKE DESIGN:**

1. The superb performance of the present detector has been demonstrated.
2. Major improvements are easily predicted.
3. Real data, for example 11-GeV  $K^-$  events, can be used to simulate KAON beams in the apparatus. These can check the Monte Carlo calculation and both on- and off- line software.
4. Interaction triggers with minimum bias can be used together with special triggers as tags, if desired. Enhancement triggers can be implemented to reach rare channels with ease and flexibility.
5. The handling of data samples with  $10^{10}$  events is not feasible now but certainly will be by the time the data is to be taken.
6. There is no comprehensive program now planned to do this job.

The major argument against this program, apart from cost, is the period required to go from this sketchy design to the data-taking stage - a period we believe to be about 5 to 10 years. The time to begin a serious design is close at hand.

LAWRENCE BERKELEY LABORATORY  
UNIVERSITY OF CALIFORNIA  
INFORMATION RESOURCES DEPARTMENT  
BERKELEY, CALIFORNIA 94720