

# Lawrence Berkeley National Laboratory

## Recent Work

### Title

Precision Analog Signal Processor For Beam Position Measurements in Electron Storage Rings

### Permalink

<https://escholarship.org/uc/item/1xs5b4w9>

### Authors

Hinkson, J.A.  
Unser, K.B.

### Publication Date

1995



# Lawrence Berkeley Laboratory

UNIVERSITY OF CALIFORNIA

## Accelerator & Fusion Research Division

Presented at the Second European Workshop on Beam Diagnostics  
and Instrumentation for Particle Accelerators, Travemunde, Germany,  
May 28-31, 1995, and to be published in the Proceedings

### Precision Analog Signal Processor for Beam Position Measurements in Electron Storage Rings

J.A. Hinkson and K.B. Unser

May 1995

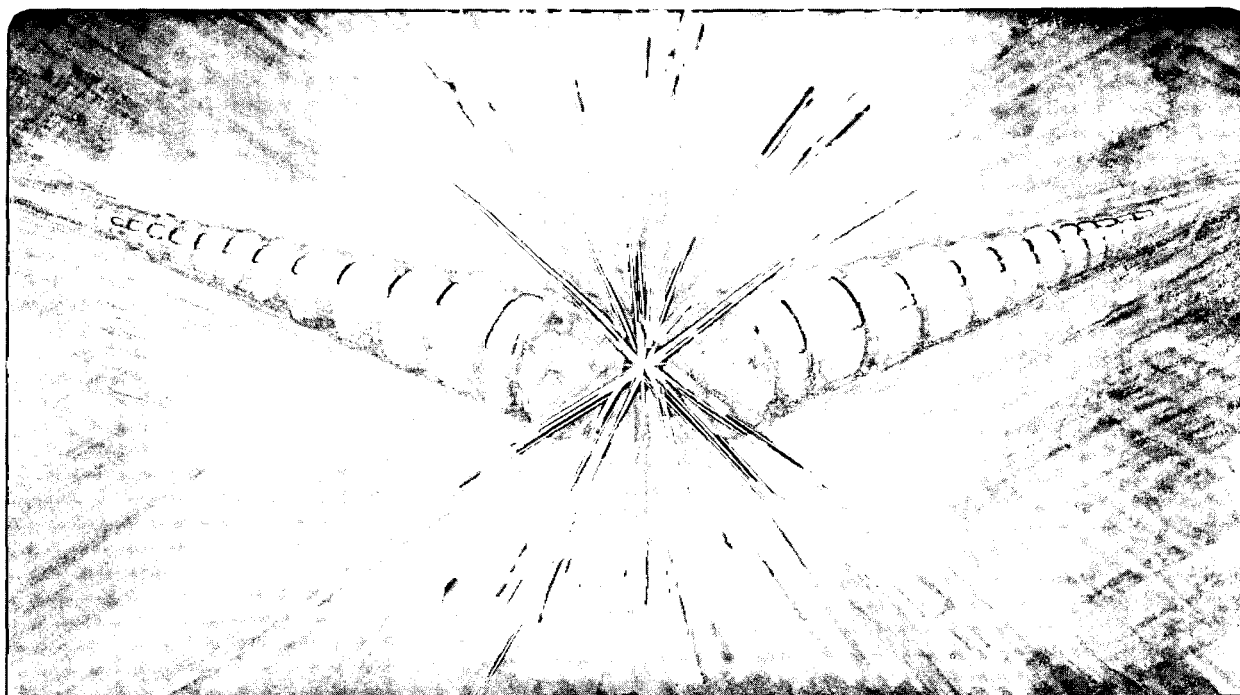

REFERENCE COPY |  
Does Not |  
Circulate |  
Bldg. 50 Library.

LBL-37005

Copy 1

## **DISCLAIMER**

This document was prepared as an account of work sponsored by the United States Government. While this document is believed to contain correct information, neither the United States Government nor any agency thereof, nor the Regents of the University of California, nor any of their employees, makes any warranty, express or implied, or assumes any legal responsibility for the accuracy, completeness, or usefulness of any information, apparatus, product, or process disclosed, or represents that its use would not infringe privately owned rights. Reference herein to any specific commercial product, process, or service by its trade name, trademark, manufacturer, or otherwise, does not necessarily constitute or imply its endorsement, recommendation, or favoring by the United States Government or any agency thereof, or the Regents of the University of California. The views and opinions of authors expressed herein do not necessarily state or reflect those of the United States Government or any agency thereof or the Regents of the University of California.

# PRECISION ANALOG SIGNAL PROCESSOR FOR BEAM POSITION MEASUREMENTS IN ELECTRON STORAGE RINGS\*

J. A. Hinkson and K. B. Unser

Advanced Light Source  
Accelerator and Fusion Research Division  
Lawrence Berkeley Laboratory  
University of California  
Berkeley, CA 94720

and

Consultant  
42 Bugnon  
01630 Street  
Genis-Pouilly, France

May 1995

Paper presented at the Second European Workshop on Beam Diagnostics and Instrumentation  
for Particle Accelerators, Travemunde, Germany, May 28-31, 1995

\*This work was supported by the Director, Office of Energy Research, Office of Basic Energy Sciences, Materials  
Sciences Division, of the U.S. Department of Energy, under Contract No. DE-AC03-76SF00098.

# Precision Analog Signal Processor for Beam Position Measurements in Electron Storage Rings\*

J. A. Hinkson<sup>1</sup> and K. B. Unser<sup>2</sup>

## Abstract

Beam position monitors (BPM) in electron and positron storage rings have evolved from simple systems composed of beam pickups, coaxial cables, multiplexing relays, and a single receiver (usually a spectrum analyzer) into very complex and costly systems of multiple receivers and processors. The older systems may have taken minutes to measure the circulating beam closed orbit. Today instrumentation designers are required to provide high-speed measurements of the beam orbit, often at the ring revolution frequency. In addition, the instruments must have very high accuracy and resolution.

A BPM has been developed for the Advanced Light Source (ALS) in Berkeley which features high resolution and relatively low cost. The instrument has a single purpose; to measure position of a stable stored beam. Because the pickup signals are multiplexed into a single receiver, and due to its narrow bandwidth, the receiver is not intended for single-turn studies. The receiver delivers normalized measurements of X and Y position entirely by analog means at nominally 1 V/mm. No computers are involved. No software is required.

Bergoz, a French company specializing in precision beam instrumentation, integrated the ALS design in their new BPM analog signal processor module. Performance comparisons were made on the ALS.

In this paper we report on the architecture and performance of the ALS prototype BPM.

## Introduction

A new beam position monitor (BPM) has been developed for the Advanced Light Source (ALS) in Berkeley. Based upon an NSLS concept [1], the new BPMs are to be used primarily for storage ring vacuum chamber protection. In 10 of 12 storage ring straight sections button electrodes have been installed for the purpose of monitoring electron beam position entering and exiting insertion devices, i.e., undulators and wigglers. Under certain conditions an errant photon beam from an insertion device may damage the vacuum chamber. The purpose of the BPMs is to sense vertical beam displacement through the insertion device and abort the beam should vertical deflection exceed 2 mm from the nominal beam orbit. A secondary purpose of the BPM is to provide feedback signals to a local beam stabilization system. The new BPM will add 20 measurement sites to the existing 96. The older BPMs [2] do have single-turn capability which is frequently used.

## Pickup Front End

The pickups used in the ALS BPM are 11 mm Metaceram type ESRF buttons. They are installed in highly elliptical chambers, 19 mm high by 90 mm wide. Their linear range of operation is small, only +/- 4 mm about the geometric center. The sensitivity of these buttons to centered beam is 6.54 %/mm in Y and 15.74 %/mm in X. This geometry is not optimum for a wide range of beam motion.

Four Helix cables approximately 30 meters long transport the button signals to the electronics. Wide-band, 6 dB attenuators are installed at the buttons to absorb reflections from the electronics. The attenuators also serve to terminate the buttons should the electronics be disconnected.

While it may seem that highly-dispersive, low-quality cable may be best to help minimize reflections, it is felt that the high degree of shielding and stability provided by Helix cable is warranted for optimum BPM performance.

The RF center frequency for the ALS BPM electronics was chosen to be 499.7 MHz. This is the only frequency in the electron bunch spectrum below 1GHz that is always available regardless of the number of bunches and their pattern. With an average current of 300 mA in the ring the 499.7 MHz signal measured at the input to the electronics is about -10 dBm. The maximum input signal anticipated is 0 dBm.

With 40 mA (average) in a single bunch, the button signal at the end of the cable is a 100 ps pulse (FWHM) greater than 50 V in amplitude.

## Electronics Front End

Because of the high single-bunch pulse amplitude, the multiplexing switches are protected by lowpass filters at the input to the RF section (Fig. 1). Apart from their insertion loss stability and constant attenuation at very high frequency, their performance is not critical. For the ALS prototype, three-section Chebychev, tubular filters with cutoff at 550 MHz were chosen. These filters reject most of the energy in the button signal. The low-loss cables transport the reflected signals back to the buttons where they are re-reflected by capacitive button reactance. The 6 dB attenuators at the buttons absorb the reflections.

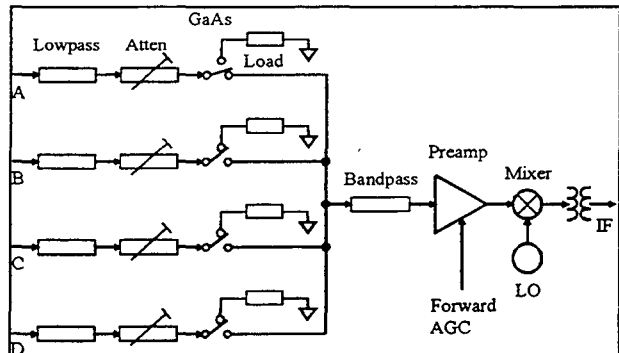

Fig. 1. BPM front end.

The attenuators following the lowpass filters are very important to the BPM function. In order to keep beam intensity related position errors to a minimum, it is essential to equalize the IF detector input signals. With perfect linearity in the RF, IF and detector sections we should expect no intensity related errors. The circuits are not perfect, so we must make sure we keep detection working over the most linear range of the receiver.

When the X and Y centers of the button array have been determined with beam-based alignment, the adjustable attenuators are set for X=0 and Y=0 at the BPM output. Then the attenuators are locked and not adjusted again. During calibration the attenuators are useful in setting up the BPM post-detector gain for the correct position sensitivity.

Anzac SW221 GaAs FET switches were chosen for the input multiplexer. These switches have low loss and high isolation. At 500 MHz the channel-to-channel and input/output isolation in the ALS prototype

<sup>1</sup> Lawrence Berkeley Laboratory, University of California, Berkeley California 94720, U.S.A.

\*This work was supported by the Director, Office of Energy Research, Office of Basic Sciences, Materials Sciences Division of the U. S. Department of Energy, under Contract No. DE-AC03-76SF00098

<sup>2</sup> Consultant, 42 Bugnon, 01630 St. Genis-Pouilly, France

exceeds 60 dB. The switches are non-reflective. That is, they terminate the BPM input in 50 ohms when they are not closed.

The switches drive a bandpass filter centered at the chosen operating frequency. Two filters have been tried in the ALS prototype. A 500 MHz, 3-section Chebychev tubular filter with 5% bandwidth and 1dB loss was used at first. Then a filter with 1% bandwidth and 6 dB loss was installed. The pulse response of the filter is not critical. The narrow-band IF filters and post-detector lowpass filters establish the BPM transient response.

The RF preamp is a Triquint TQ9114 low-noise, AGC amplifier with 30 dB gain range. It drives an active mixer, RF Micro Devices type RF2401. The IF output of the mixer at 21.4 MHz is filtered and sent to the IF processor. The filter presents 50 ohms to the out-of-band mixing products.

The local oscillator in the ALS prototype is a Vectron crystal controlled oscillator operating at 478.26 MHz.

### IF Amplifier and Detector

We desire precision detection of the 21.4 MHz IF signal to obtain the relative amplitude of the multiplexed button signals. It is common today to use television IF and video processing integrated circuits (IC) for this purpose. The NLSL BPM [1] uses Motorola ICs, the MC1350 and MC1330. The 96 BPMs currently in use at the ALS [2] have the National LM1211 (no longer available). The amplitude detectors in these ICs are quasi-synchronous. An amplitude limited version of the IF signal is compared with the linear signal. When the IF signal is small, these detectors have trouble with precision detection. In the new BPM we use the National LM1823, a complete television IF processing IC with AGC IF amplifier, AGC circuits, phase locked loop (PLL), and LO automatic frequency control (AFT). The PLL provides a true synchronous detector when it is locked. The phase of the synchronous detector reference input is constantly locked to the IF signal. This provides superior dynamic range compared to the quasi-synchronous detector.

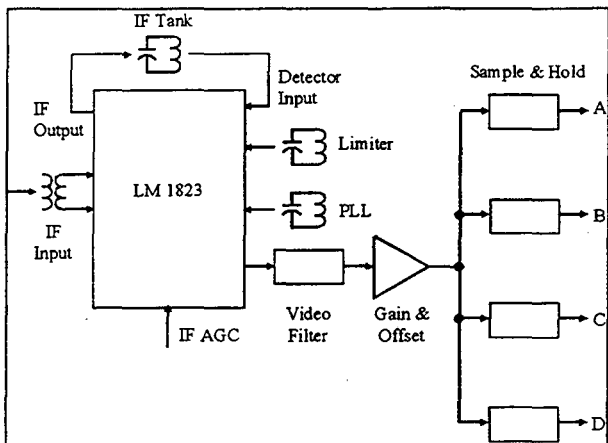

Fig. 2. IF amplifier and demodulation.

The LM1823 1823 IF amplifier is gain-controlled over a 50 dB range. A single-tuned bandpass filter with 500 kHz bandwidth selects the desired frequency and drives the detector input. Two other tuned circuits set the amplitude limiter and PLL frequency. These tuned circuits have bandwidth similar to the IF tank circuit.

The video detector bandwidth is 9 MHz, much greater than required. The detector quiescent output voltage is 7.5 V. At maximum IF input the detector output falls to 1.5 V. The linear operating range of the detector is approximately 3 V. A low-pass filter rejects the synchronous detector sum frequency components and switching transients. A buffer amplifier and active lowpass filter serve to limit video bandwidth, increase the voltage swing, and remove detector DC offset.

Since the local oscillator in the RF section is crystal controlled, there is no need to use the LM1823 AFC capability.

Demodulation of the individual button voltages is performed by LF398 sample and hold ICs. At the sample and hold outputs we have the individual button voltages which are subsequently processed to obtain beam position.

### Analog Processing

Three sections of operational amplifiers are necessary to perform button signal sums and differences. OP27 amplifiers are used here. We add all four signals to obtain the "Sum" signal which is used to control the gain of the RF and IF amplifiers. In this case the Sum signal is maintained at exactly 3.00 V over the dynamic range of the instrument. This form of beam intensity normalization makes it unnecessary for us to use analog multipliers (dividers) or digitizers and computers to perform the difference over sum calculations. See Fig. 3.

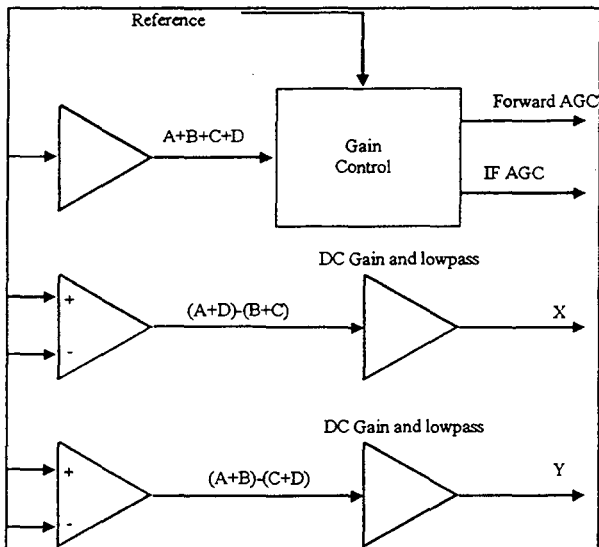

Fig. 3. Gain control and analog processing.

To obtain position information we take differences between the button signals and apply gain commensurate with button sensitivity. In the case of four pickups rotated off the horizontal and vertical plane, we subtract the sums of C and D from A and B to find the vertical position. Horizontal beam position is found by subtracting the sums of A and D from the sum of B and C. When pickups are arranged in the horizontal and vertical planes, the analog calculations are simpler. To accommodate beam pickups of different geometry and sensitivity, we simply change the amplifier gains and resistor connections.

### Aliasing and Multiplexing

Because we sequentially switch between the pickup buttons there is a possibility of aliasing [1] high frequency beam motion (longitudinal or transverse). In the ALS we observe synchrotron beam oscillations at between 8 and 12 kHz. Betatron sidebands appear about beam rotation harmonics at approximately +/- 375 kHz. In order to determine the BPM's susceptibility to synchrotron oscillations we angle-modulated test signals and adjusted the degree of modulation to match measured beam oscillations. Then the multiplexing rate was adjusted over a range of frequencies. We determined experimentally that a switch rate of 5.625 kHz was sufficient for the BPM to be insensitive to ALS synchrotron oscillations. With the incorrect multiplexing rate we observed erroneous beam motion of approximately 20 microns.

Ordinarily we would like to set the multiplexing rate at least twice as high as the highest synchrotron frequency to avoid aliasing. This would require us to switch at 25 kHz or more. This may conflict with our desire to have the BPM insensitive to bunch loading patterns. We do not want to have an IF bandwidth wide enough to show single bunch response at the output of the detector.

The GaAs switches and sample and hold ICs are controlled by the system clock running at 90 kHz. A programmable array logic (PAL) and a

CMOS counter reduce the switching rate, generate the sequential input switch gate-control pulses, and the sample and hold triggers. The internal clock may be replaced by an external timer if desired. Regardless of the clock frequency, the sample and hold triggers are always 1/4 the width of the gate-control pulses and occur at exactly 1/2 the pulse width.

#### Production of the BPM Signal Processors

Bergoz, a French company specializing in precision beam instrumentation, proposed to integrate the ALS design in their new BPM analog signal processor module. The circuits were reengineered into a single-height Eurocard and manufacturing costs were reduced significantly. This will permit substantial savings in the production of the 20 units needed at the ALS. This industrialized module is not designed specifically for the ALS, but intended to be used on a variety of accelerators, covering a wide range of frequency and signal levels.

#### Measurements

In the laboratory we measured the BPM output noise at two RF input levels, -7 dBm and -57 dBm. These levels are commensurate with 400 mA and 1.3 mA in the ALS storage ring. Figures 4 and 5 are graphs showing BPM noise measured from DC to 400 Hz. Frequency resolution is 1 Hz. No averaging was used. The Y axis output is shown. X axis noise is about 6 dB lower.

The BPM signal processor from Bergoz was tested at the ALS and compared with the ALS prototypes. Resolution and offset linearity were measured. The Bergoz BPM exhibits the same performance and general behavior.

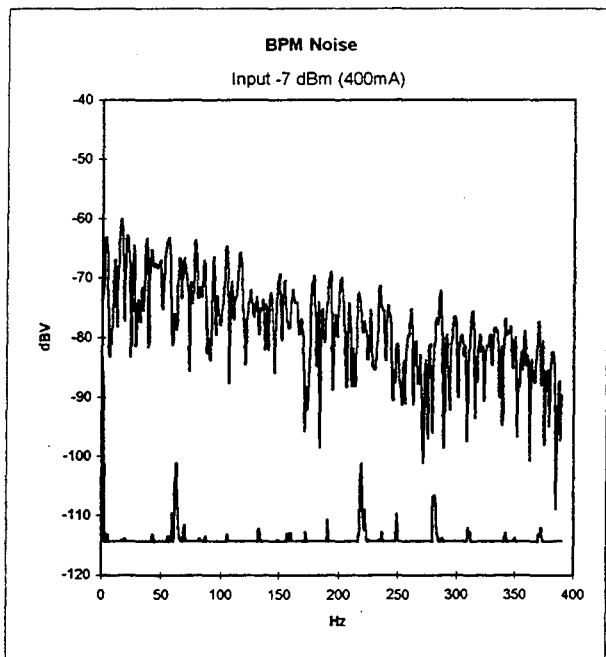

Fig. 4. Y axis output noise at high input level. (1 V = 0 dBV = 1 mm)

Figure 4 indicates the low frequency noise is less than 1 micron (sensitivity is 1 V/mm. -60 dBV equals 1 micron) The lower amplitude data represent the instrument noise floor.

Figure 5 indicates noise with an RF input equivalent to 1.3 mA in the ring. There is about a 3 dB rise in the noise compared to Fig. 4.

With data taken over one hour, the baseline drift was less than 1 micron. Intensity effects with equal beam pickup signals is essentially zero. With 1 mm X deflection simulated using the variable attenuators, we see about +/- 1 micron shift as the signal is attenuated from -7 to -17 dBm. At larger displacements the error grows somewhat.

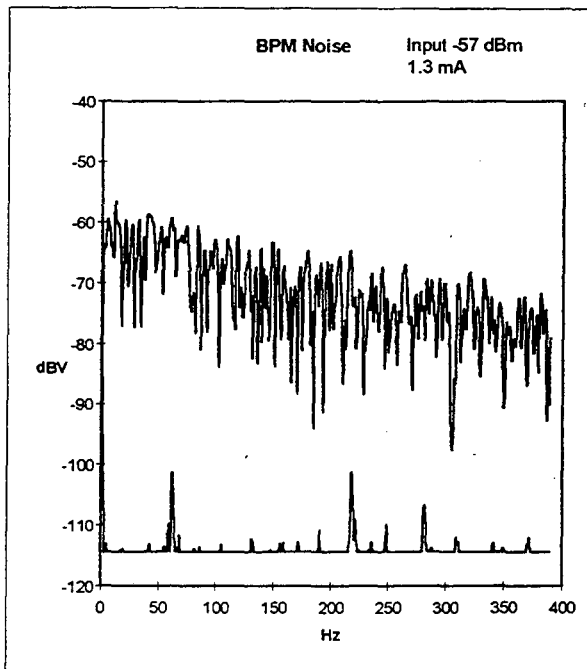

Fig. 5. BPM output noise with -57 dBm input. (1 V = 0 dBV = 1 mm)

#### Conclusion

The new BPM has demonstrated its value during ALS operations. We have been able to clearly measure +/- 2 micron vertical beam motion which was correlated with a 12 minute temperature cycle in magnet cooling water. Other beam motion in the X axis has been correlated with hourly cycles in tunnel air temperature.

Two more prototype BPMs have been fabricated and are being installed near an undulator to determine if the BPM stability and resolution are sufficient for photon beam stabilization. It is clear that the BPM will function well in the beam interlock system.

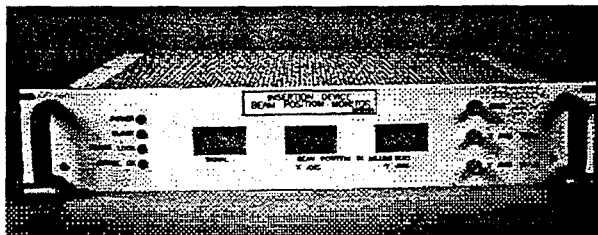

Fig. 6. The ALS prototype BPM

#### References

- [1] R. Biscardi, J.W. Bittner, "Switched Detector for Beam Position Monitor", in the Proceedings of the IEEE Particle Accelerator Conference, Vol. 3, p. 1516, (1989)
- [2] J. Hinkson, "Advanced Light Source Beam Position Monitor", AIP Conference Proceedings No. 252, Accelerator Instrumentation Workshop, p. 21, (1991)

LAWRENCE BERKELEY LABORATORY  
UNIVERSITY OF CALIFORNIA  
TECHNICAL AND ELECTRONIC  
INFORMATION DEPARTMENT  
BERKELEY, CALIFORNIA 94720