

Lawrence Berkeley National Laboratory

LBL Publications

Title

Broad-Band Characteristics of Circular Button Pickups

Permalink

<https://escholarship.org/uc/item/1zk2h96z>

Author

Barry, W C

Publication Date

1992-10-01



Lawrence Berkeley Laboratory

UNIVERSITY OF CALIFORNIA

Accelerator & Fusion Research Division

Presented at the 1992 Accelerator Instrumentation
Workshop, Berkeley, CA, October 27-30, 1992,
and to be published in the Proceedings

Broad-Band Characteristics of Circular Button Pickups

W.C. Barry

October 1992

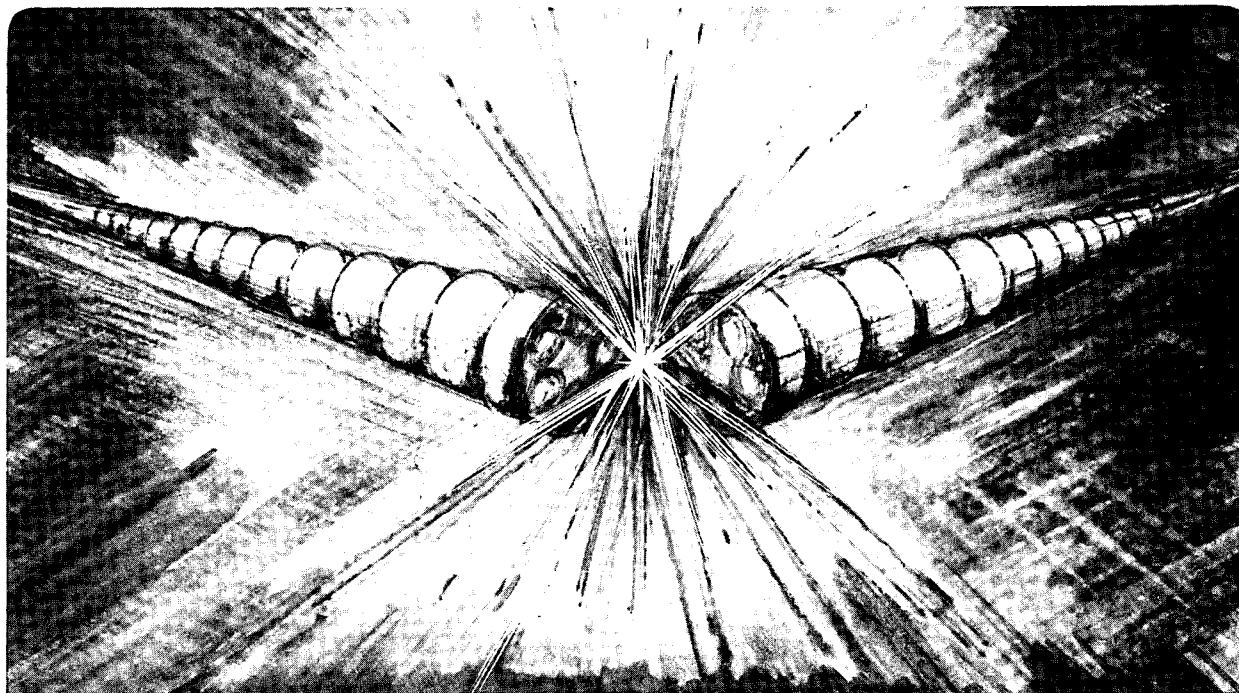

Prepared for the U.S. Department of Energy under Contract Number DE-AC03-76SF00098

REFERENCE COPY |
Does Not |
Circulate |
Bldg. 50 Library.

LBL-32939

Copy 1

DISCLAIMER

This document was prepared as an account of work sponsored by the United States Government. Neither the United States Government nor any agency thereof, nor The Regents of the University of California, nor any of their employees, makes any warranty, express or implied, or assumes any legal liability or responsibility for the accuracy, completeness, or usefulness of any information, apparatus, product, or process disclosed, or represents that its use would not infringe privately owned rights. Reference herein to any specific commercial product, process, or service by its trade name, trademark, manufacturer, or otherwise, does not necessarily constitute or imply its endorsement, recommendation, or favoring by the United States Government or any agency thereof, or The Regents of the University of California. The views and opinions of authors expressed herein do not necessarily state or reflect those of the United States Government or any agency thereof or The Regents of the University of California and shall not be used for advertising or product endorsement purposes.

Lawrence Berkeley Laboratory is an equal opportunity employer.

DISCLAIMER

This document was prepared as an account of work sponsored by the United States Government. While this document is believed to contain correct information, neither the United States Government nor any agency thereof, nor the Regents of the University of California, nor any of their employees, makes any warranty, express or implied, or assumes any legal responsibility for the accuracy, completeness, or usefulness of any information, apparatus, product, or process disclosed, or represents that its use would not infringe privately owned rights. Reference herein to any specific commercial product, process, or service by its trade name, trademark, manufacturer, or otherwise, does not necessarily constitute or imply its endorsement, recommendation, or favoring by the United States Government or any agency thereof, or the Regents of the University of California. The views and opinions of authors expressed herein do not necessarily state or reflect those of the United States Government or any agency thereof or the Regents of the University of California.

LBL-32939
ESG-211

Broad-Band Characteristics of Circular Button Pickups*

Walter C. Barry

Lawrence Berkeley Laboratory
University of California
Berkeley, CA 94720

Presented at the 1992 Accelerator Instrumentation Workshop
to be held at Lawrence Berkeley Laboratory, Berkeley, CA, Oct. 27-30, 1992

* This work was supported by the Director, Office of Energy Research, Office of Basic Energy Sciences, Materials Sciences Division, of the U.S. Department of Energy under Contract No. DE-AC03-76SF00098.

BROAD-BAND CHARACTERISTICS OF CIRCULAR BUTTON PICKUPS*

Walter C. Barry

Lawrence Berkeley Laboratory
University of California
Berkeley, CA 94720

ABSTRACT

A broad-band theory of the circular button pickup is presented. Expressions for the longitudinal and transverse transfer impedance of a pair of such pickups are derived in the frequency domain. The broad-band expressions are shown to reduce to the standard electrostatic transfer functions for wavelengths large compared to the button diameter. The theory is shown to be in reasonable agreement with measurements performed on standard LEP button electrodes. In particular, the theory explains a resonance in the response of the LEP buttons which made them unsuitable, in standard form, for their intended application as pickups in the LBL Advanced Light Source feedback system. The buttons were modified to suppress the resonance and subsequently incorporated into the feedback system.

INTRODUCTION

Circular button pickups/electrodes are employed in beam position monitors and other diagnostic devices in a wide variety of particle accelerators [1]. With sensitivities lower than the other major pickup (stripline) used in accelerators, button pickups are frequently found in applications where peak beam currents are relatively high, such as in colliders and light source storage rings. Button pickups are particularly well suited to these applications because they are broadband, mechanically simple, and have low beam impedance.

The standard analysis of the button pickup consists of an electrostatic treatment of the electrode as an image charge collection device [2]. For wavelengths large compared to the button diameter, this model is in excellent agreement with experimental results. In some applications, such as time domain measurements involving short bunches, a more general theory is required due to the presence of high frequency signal components with wavelengths on the order of, or smaller than the button diameter. An example of such an application of button pickups is in the LBL Advanced Light Source (ALS) feedback systems for controlling coupled bunch instabilities [3].

The longitudinal and transverse feedback systems for the ALS are both broadband systems designed to damp instabilities on a bunch by bunch basis. In this case, pickups are used to detect an error in phase or position of a single bunch from which a correction signal is derived and applied to that same bunch. For the reasons cited above, a standard 3.4 cm diameter LEP button was chosen for this pickup application [4].

The electron bunches in the ALS storage ring have a width of $2\sigma \approx 28$ psec with a spacing of 2 nsec (500 MHz RF) between adjacent buckets. It should be clear that such a short bunch contains frequency components of significant amplitude well into the tens of gigahertz. Therefore, any high frequency resonances associated with

* This work was supported by the Director, Office of Energy Research, Office of Basic Energy Sciences, Materials Sciences Division, of the U.S. Department of Energy under Contract No. DE-AC03-76SF00098.

the response of the pickups can easily be excited by the bunch. Because of the short 2 nsec duration between bunches, a resonance with even a relatively low Q in a pickup will cause the error signal from one bunch to linger and interfere with the signal from the next bunch, possibly degrading the performance of the feedback system.

In the course of bench testing the LEP buttons with an impedance matched wire setup and a short (60 psec) pulse generator to simulate the bunch, a resonance in the pickup response with a Q high enough to cause concern was found at 4.4 GHz. In an effort to explain this response and provide guidance in modifying the button to suit the needs of the ALS, the general analysis of circular button pickups presented in this paper was formulated. In the next section, a general analysis of the circular button pickup is presented. Subsequently, the theory is applied to the LEP button electrode discussed above and compared with the bench measurements.

THEORY OF THE CIRCULAR BUTTON PICKUP

The pickup configuration to be analyzed is schematically illustrated in figure 1a. The pickup consists of a pair of circular electrodes of radius, a , mounted parallel to the upper and lower walls of a beam chamber represented by two infinite parallel planes. The electrodes are spaced a distance, d , from the ground plane, terminated with resistors, R (usually 50 Ω), and may be loaded with a dielectric, ϵ_r . A beam with phasor current amplitude, I_b , passes by the electrodes at $x=0$, $y=\Delta y$, inducing voltages, V^\pm , across the resistors. The goal of the analysis will be to find frequency domain expressions for the longitudinal and transverse pickup impedances, defined as:

$$Z_{\parallel} = \frac{V^+ + V^-}{I_b} \Big|_{\Delta y=0} \quad \Omega \quad (1)$$

$$Z_{\perp} = \frac{\partial(V^+ - V^-)}{I_b \partial \Delta y} \Big|_{\Delta y=0} \quad \Omega/m \quad (2)$$

Each electrode and its associated ground plane is modeled as a pair of circular planes of radius, a , separated by a dielectric, ϵ_r , of thickness, d (see figure 1b). As shown in figure 1b, the terminating resistor is represented by a cylindrical surface resistance, R_s , at some radius, b . In this case:

$$R_s = \frac{2\pi b R}{d} \quad (3)$$

The circular planes are driven by a magnetic source, $H_s(\phi) \hat{\phi}$, which represents the component of magnetic field from the beam at $r=a$, $y = \pm w/2$, which is tangent to the surface, $r=a$. The fields inside the dielectric region are assumed to be TM without y variation. In this case, the field components satisfying the Helmholtz equation can be written:

$$E_y(r, \phi) = \sum_{n=0}^{\infty} [A_n J_n(kr) + B_n Y_n(kr)] \cos n \phi \quad (4a)$$

$$H_\phi(r, \phi) = \frac{-j\sqrt{\epsilon_r}}{Z_0} \sum_{n=0}^{\infty} [A_n J'_n(kr) + B_n Y'_n(kr)] \cos n \phi \quad (4b)$$

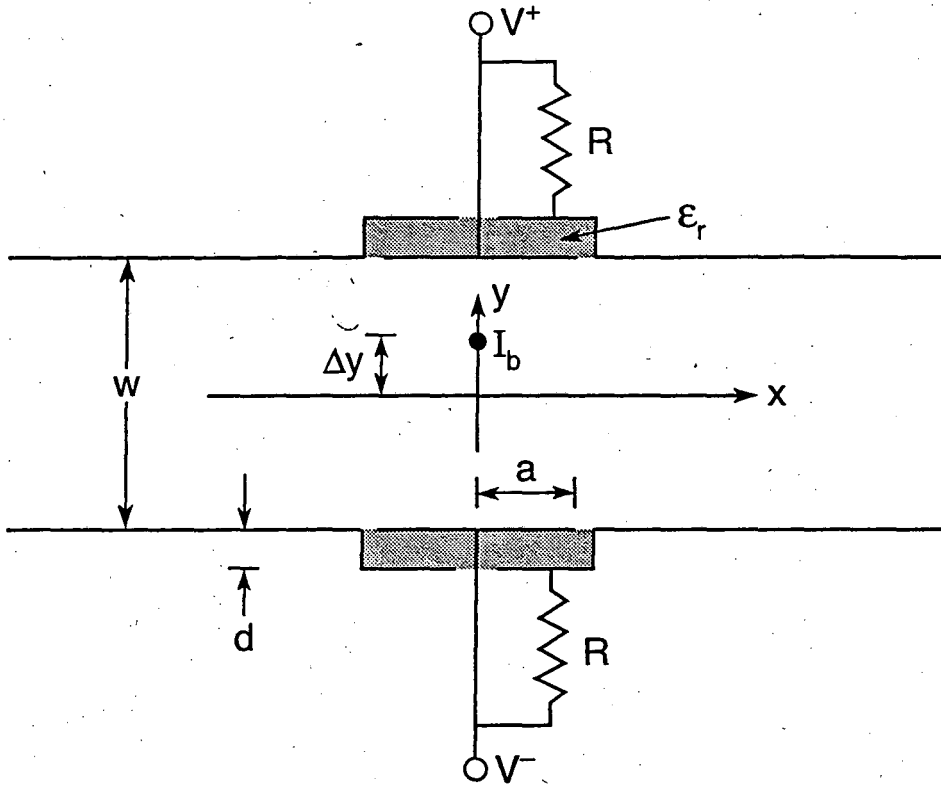

Figure 1a. Circular button pickup geometry.

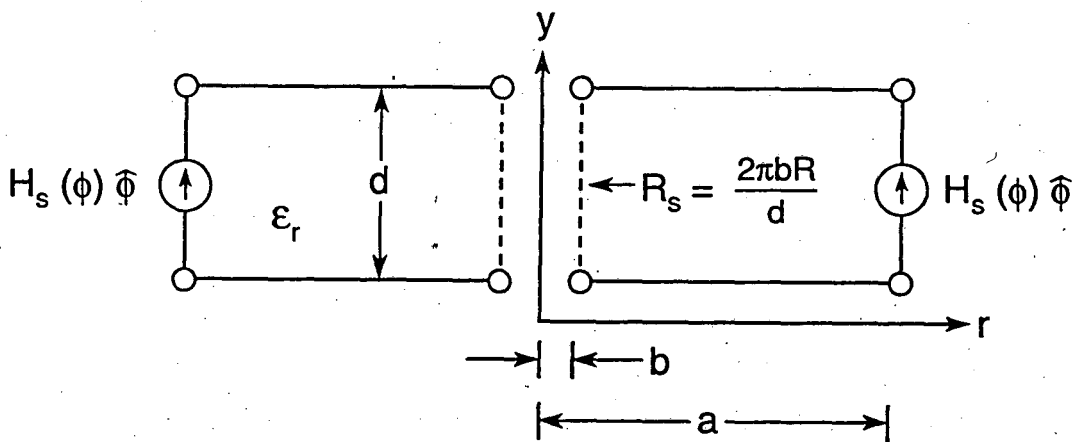

Figure 1b. Button pickup model (top button-side view).

In equations (4a) and (4b), $k = \sqrt{\epsilon_r} k_o$, $Z_o = 377 \Omega$, and $J_n(x)$ and $Y_n(x)$ are n^{th} order Bessel functions of the first and second kind. The coefficients A_n , B_n are determined by the boundary condition at $r=b$:

$$E_y(b, \phi) = R_s H_\phi(b, \phi), \quad (5a)$$

and through Fourier expansion of the excitation condition:

$$H_{\phi}(a, \phi) = H_s(\phi) \quad (5b)$$

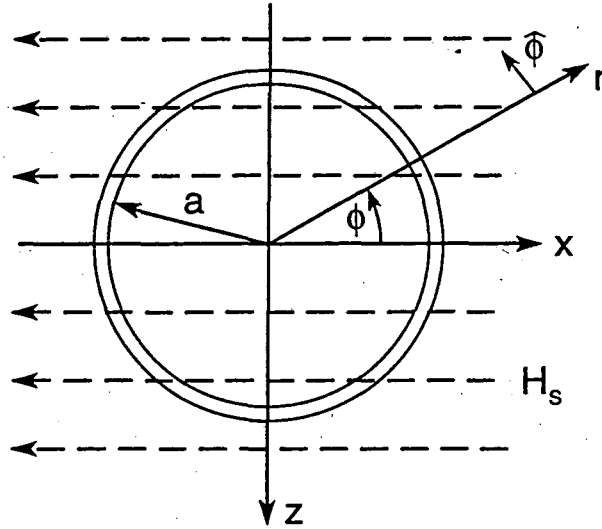

Figure 1c. Button pickup model (top button-top view).

An instrument that measures voltage between the two circular planes at the resistive surface, $r=b$, will respond to:

$$V = I_y R \quad (6)$$

In equation (6), I_y is the net current flowing through the resistor, which in this case, is entirely in the y direction:

$$I_y = \int_0^{2\pi} H_{\phi}(b, \phi) b d\phi \quad (7)$$

Equation (4b) reveals that the only azimuthal harmonic of $H_{\phi}(r, \phi)$ that contributes to I_y is the $n=0$ harmonic. Stated another way, a lumped element device symmetrically connected to the surface resistor will measure the average voltage to which $n>0$ harmonics do not contribute. Therefore, equations (4) and (5) may be reduced to:

$$E_y(r) = A_0 J_0(kr) + B_0 Y_0(kr) \quad (8a)$$

$$H_{\phi}(r) = \frac{j\sqrt{\epsilon_r}}{Z_0} [A_0 J_1(kr) + B_0 Y_1(kr)] \quad (8b)$$

$$E_y(b) = R_s H_{\phi}(b) \quad (9a)$$

$$H_{\phi}(a) = H_0 = \frac{1}{2\pi} \int_0^{2\pi} H_s(\phi) d\phi \quad (9b)$$

The quantity of interest is the voltage across the surface resistance, which for the upper and lower electrodes, is given by:

$$V^{\pm} = \pm d E_y^{\pm}(b) \quad (10)$$

The electrode voltages are found by applying the boundary and excitation conditions, (9), to the field expressions, (8):

$$V^{\pm} = \frac{\mp 2Z_o d H_o^{\pm}}{\pi \sqrt{\epsilon_r} kb \left(\frac{d Z_o}{2\pi b R \sqrt{\epsilon_r}} r_o(ka, kb) + j p_1(ka, kb) \right)} \quad (11)$$

where:

$$r_o(x, y) = Y_1(x)J_o(y) - J_1(x)Y_o(y) \quad (12)$$

$$p_1(x, y) = J_1(x)Y_1(y) - Y_1(x)J_1(y) \quad (13)$$

The remaining task consists of calculating the source terms H_o^{\pm} . As shown in figure 1c, a beam current traveling in the z direction carries a transverse magnetic field which is tangent to the conducting planes and electrodes at $y = \pm w/2$. Assuming a relativistic beam, the magnetic field may be obtained from the magnetostatic solution to a line current between two conducting planes. This problem is completely analogous to the electrostatic potential problem of a line charge between two planes, the solution to which can be found in numerous references (see for instance [5]). The resulting magnetic fields at the upper and lower electrodes are uniform in x under the assumption $a \ll w$ and are given by:

$$H_x^{\pm}(\Delta y, z) = \mp \frac{I_b}{2w} e^{-j k_o z} \left[\frac{1}{1 \mp \frac{\pi \Delta y}{w}} \right] \quad a \ll w \quad (12)$$

The source terms, H_o^{\pm} , are found by transforming (12) to polar coordinates and substituting into (9b):

$$H_o^{\pm} = \pm \frac{j I_b}{2w} \left[\frac{J_1(k_o a)}{1 \mp \frac{\pi \Delta y}{w}} \right] \quad (13)$$

Substituting (13) into (11), and subsequently (11) into (1) and (2), yields the desired results for the longitudinal and transverse pickup impedances:

$$Z_{\parallel} = \eta g \left[\frac{-j J_1(k_o a)}{\frac{\sqrt{\pi}}{4} \frac{\eta}{R} (ka) r_o(ka, kb) + j \frac{\pi}{2} (kb) p_1(ka, kb)} \right] \quad \Omega \quad (14)$$

$$Z_{\perp} = \frac{\pi}{w} Z_{\parallel} \quad \Omega/m \quad (15)$$

where:

$$\eta = \frac{Z_0 d}{\sqrt{\epsilon_r} \sqrt{\pi a}} \quad \Omega \quad (16)$$

$$g' = \frac{\sqrt{\pi a}}{w} \quad (17)$$

For convenience, the pickup impedance is written in terms of the parameter, η , which equals the characteristic impedance of a dielectric filled parallel plane TEM transmission line of width, $\sqrt{\pi a}$, and gap, d . The parameter, g , is a simple geometric factor. Equation (15) shows that the longitudinal and transverse pickup impedances are related by the simple multiplicative factor, π/w . If the electrode pair is used as a beam position monitor, the derivative of the difference over sum voltage with respect to beam position, Δy , equals π/w for small Δy . Due to space constraints and the complexity of (14), it is impractical to present a general investigation into the behavior of the button response as a function of the various physical parameters involved. Therefore, discussion of the circular button response will be limited to the specific example of the ALS pickups presented in the next section. One important characteristic of the button response may be found by examining (14) for wavelengths large compared to the button radius. In this case:

$$Z_{||} = \frac{\eta g}{\sqrt{\epsilon_r}} \left(\frac{j \omega RC}{1 + j \omega RC} \right) \quad \Omega \quad (18)$$

where:

$$C = \frac{\epsilon_0 \epsilon_r \pi a^2}{d} \quad \text{farads} \quad (19)$$

This is the standard expression for the pickup impedance of a pair of button electrodes in the electrostatic approximation.

ALS FEEDBACK (LEP BUTTON) PICKUPS

The pickups intended for the ALS feedback system were the model EB-35 LEP button electrodes shown in figure 2. Clearly, the actual button geometry is more complicated than the model given in the previous section. Therefore, several approximations are made in order to apply equation (14). Without approximation, the button radius and gap are given by a and d in figure 2. The radius of the equivalent surface resistance is taken as the outer radius of the coaxial line leading to the button. The most troublesome difference between the model and the actual button is the alumina spacer which does not fill the entire gap. As an approximation for the model, an equivalent dielectric which fills the entire region between $r=b$ and $r=a$ is used. Time domain reflectometry measurements yield a total button capacitance of 8 pf. A rough calculation of capacitance for the geometry of figure 2 with $\epsilon_r=9$ for alumina also gives 8 pf. By requiring that the capacitance of the annular region from $r=b$ to $r=a$ be 8 pf while holding d constant, an equivalent dielectric of $\epsilon_r=4.3$ is calculated.

Using the button dimensions given in figure 2 and $\epsilon_r=4.3$, the amplitude and phase of the quantity $Z_{||}/gR$ were calculated and plotted in figure 3. As shown, the model response exhibits a resonance with $Q=4$ at 6 GHz. The actual response of the button was measured using a standard wide-band impedance matched wire setup and a 60 psec pulse generator. The response of the button to the 60 psec pulse is shown in figure 4. The actual button exhibits a resonance at 4.4 GHz which is somewhat lower

than the predicted frequency of 6 GHz. This might be expected because of the crudeness of the model, which among other things, does not account for the non-uniform dielectric, fringing capacitance, and any mismatch of the load to the transmission line leading to the button. The measured Q from figure 4 is 3.6 and is in good agreement with the theoretical Q of the model. For comparison, the response of the button to a 300 psec pulse is shown in figure 5. Because the 300 psec pulse has very little 4.4 GHz content, the resonance is not excited and the time response is given by the inverse Fourier transform of the low frequency expression (18).

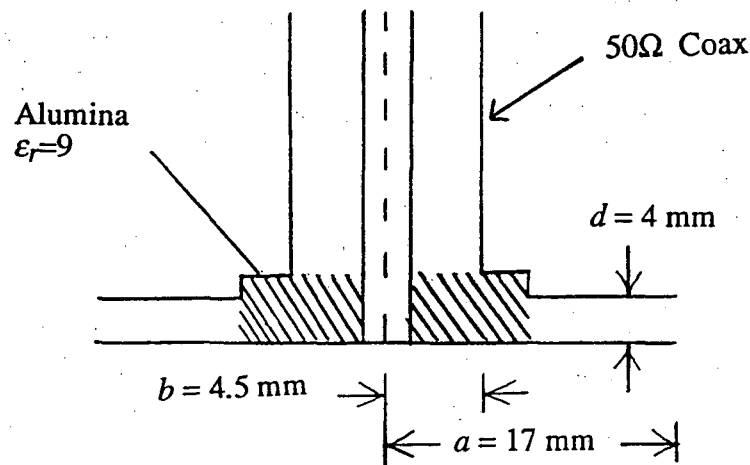

Figure 2. LEP button pickup.

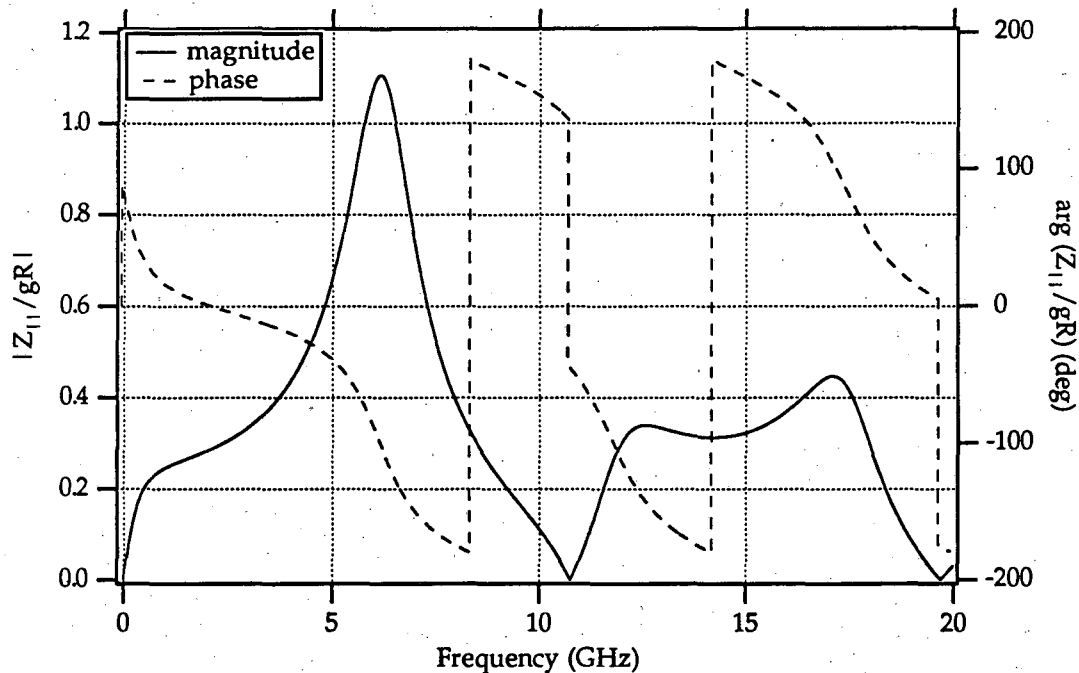

Figure 3. Amplitude and phase of modeled response.

Despite the discrepancy between the theoretical and measured resonant frequencies, the model gives excellent qualitative insight into the behavior of the

button pickup. By investigating (14) as a function of the various physical parameters involved, it was found that for the first passband, the response of the circular electrode was roughly similar to that of a center-terminated square stripline electrode of equal area, hence the choice of definitions for η and g . For the special cases of $\epsilon_r=1$ and $\epsilon_r=4$, it can be shown that the square stripline resonates when its length is one half free space wavelength or equivalently, when the distance from the edge of the pickup to the termination is one quarter free space wavelength. In the case $\epsilon_r=4$, the wave velocity on the stripline is one half the velocity of the relativistic beam. This factor of two difference in wave and beam velocities over the $\lambda/4$ free space distance explains the $-\pi/2$ phase shift at resonance (see figure 3). In addition, it was found that for $\epsilon_r=1$, the Q of the resonance increases with η/R , while for $\epsilon_r=4$, the Q decreases with increasing η/R . In both cases, when $\eta/R = 2$, the standard matched stripline response results for the square pickup approximation. A similar response (i.e. approximately linear phase) is obtained for $\eta/R \approx 2$ in the case of the circular electrode.

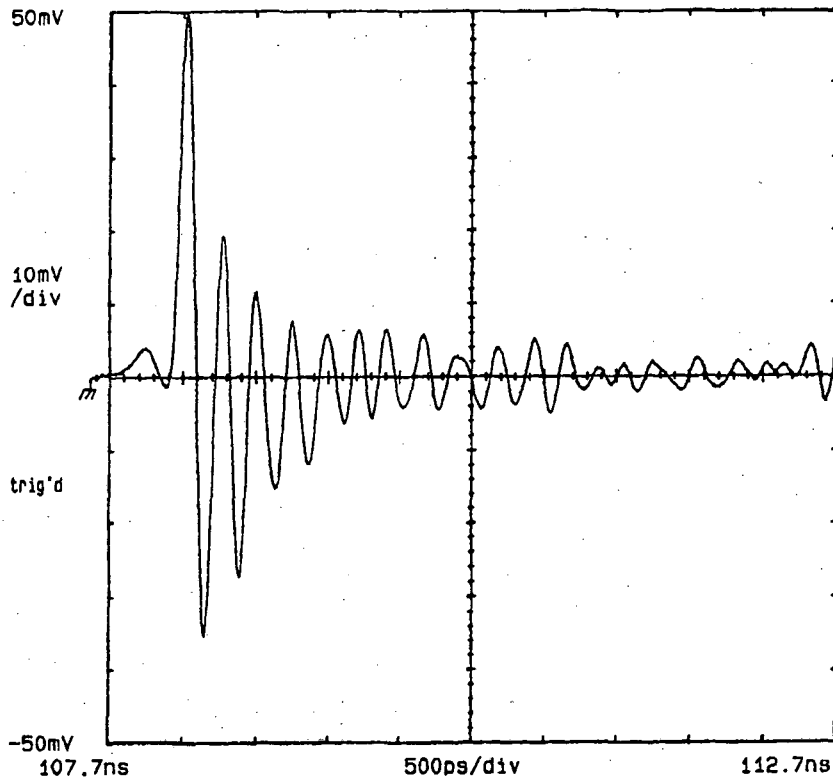

Figure 4. 60 psec pulse response of LEP button.

Given the above characteristics, several options for modifying the LEP buttons to suppress the resonance existed. Removal of the alumina spacer and/or modification of the gap size would result in some control over Q . However, the spacer is an integral part of the mechanical design of the electrode so that removing it or changing its size would be a difficult task. As a compromise, the alumina spacer was replaced with an identical spacer machined from NZ-51 ferrite. In addition, the button diameter was reduced to approximately the diameter of the spacer (1.7 cm). The lossy ferrite material decreases the Q of the resonance while the smaller button diameter serves to increase the resonant frequency, thus decreasing the bunch's ability to excite the resonance. The response of the modified button to the 60 psec pulse is

shown in figure 6. The modifications resulted in an increase in resonant frequency to 6.2 GHz. The Q was decreased somewhat and is difficult to measure in this case. However, as indicated by the dashed curve, the overall response resembles that of the circular electrode in the low frequency regime. The modifications to the button also reduced its sensitivity by a factor of two. However, because of the high bunch currents in the ALS storage ring, the reduction in sensitivity is insignificant. Finally, it should be pointed out that the 28 $psec$ light source bunches will have about twice the relative 6.2 GHz frequency content as the 60 $psec$ test pulse. The response of the pickups, which are currently installed in the storage ring, to the actual bunches will be measured over the next several months.

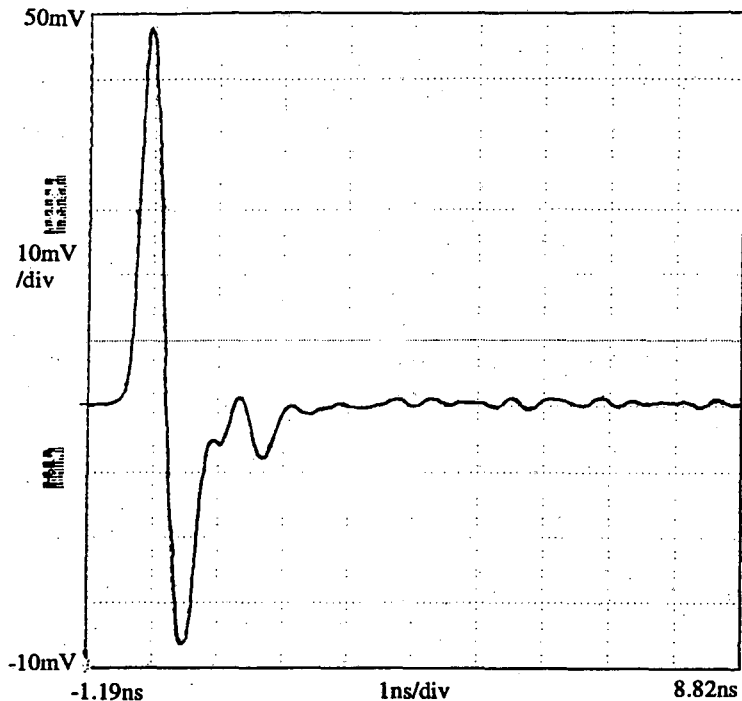

Figure 5. 300 psec pulse response of LEP button.

SUMMARY

A broad-band model and analysis of circular button pickups has been presented. The model was used to predict a resonance found in the LEP pickups used in the ALS feedback systems. The model gave results that were in good qualitative and quantitative agreement with measured data. The model also served as a guide for modifying the LEP buttons to suppress the resonance.

ACKNOWLEDGMENTS

The author wishes to thank Glen Lambertson for many enlightening discussions, John Byrd for providing the plot of the theoretical button response, and Jim Hinkson for providing the measured data on the LEP buttons. All of the collaborators are with Lawrence Berkeley Laboratory.

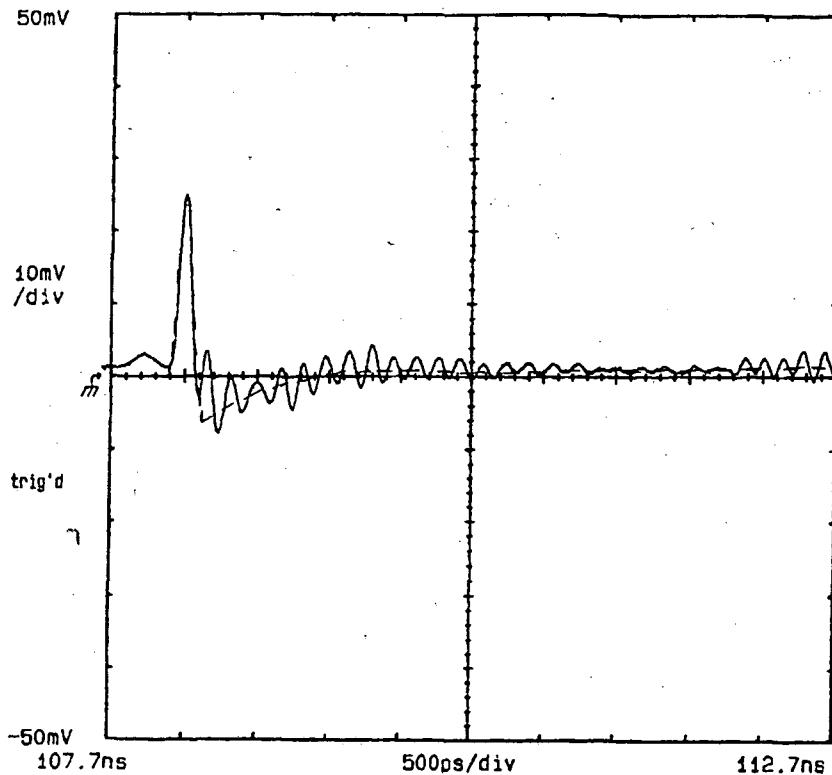

Figure 6. 60 psec pulse response of modified LEP button.

REFERENCES

- [1] J. Borer and R. Jung "Diagnostics," CERN/LEP-B1/84-14 (October 1984).
- [2] D.A. Goldberg and G.R. Lambertson, "Dynamic Devices A Primer on Pickups and Kickers," to be published in AIP Conference Proceedings Series - Physics of Particle Accelerators, Mel Month and Margaret Vienes, Eds., American Institute of Physics, New York, N.Y., 1992 (LBL-31664).
- [3] J. Fox, "Bunch by Bunch Beam Damping," Elsewhere in these proceedings.
- [4] J. Borer, "Instrumentation and Diagnostics Used in LEP Commissioning, With Accent on the LEP Beam Orbit Measurement System," Proceedings of the 1990 Accelerator Instrumentation Workshop, Batavia, IL, 1990, AIP Conference Proceedings no. 229.
- [5] W.K.H. Panofsky, and M. Phillips, "Classical Electricity and Magnetism," Addison-Wesley, Menlo Park, CA 1962.

LAWRENCE BERKELEY LABORATORY
UNIVERSITY OF CALIFORNIA
TECHNICAL INFORMATION DEPARTMENT
BERKELEY, CALIFORNIA 94720