

Lawrence Berkeley National Laboratory

Lawrence Berkeley National Laboratory

Title

Energy Efficient Indoor VOC Air Cleaning with Activated Carbon Fiber (ACF) Filters

Permalink

<https://escholarship.org/uc/item/25t6t6pq>

Author

Sidheswaran, Meera

Publication Date

2011-09-01

DOI

10.1016/j.buildenv.2011.07.002



**ERNEST ORLANDO LAWRENCE
BERKELEY NATIONAL LABORATORY**

Energy Efficient Indoor VOC Air Cleaning with Activated Carbon Fiber (ACF) Filters

Meera A. Sidheswaran, Hugo Destailats, Douglas P. Sullivan,
Sebastian Cohn, and William J. Fisk,

Lawrence Berkeley National Laboratory

Environmental Energy Technologies Division

July 2011



DISCLAIMER

This document was prepared as an account of work sponsored by the United States Government. While this document is believed to contain correct information, neither the United States Government nor any agency thereof, nor the Regents of the University of California, nor any of their employees, makes any warranty, express or implied, or assumes any legal responsibility for the accuracy, completeness, or usefulness of any information, apparatus, product, or process disclosed, or represents that its use would not infringe privately owned rights. Reference herein to any specific commercial product, process, or service by its trade name, trademark, manufacturer, or otherwise, does not necessarily constitute or imply its endorsement, recommendation, or favoring by the United States Government or any agency thereof, or the Regents of the University of California. The views and opinions of authors expressed herein do not necessarily state or reflect those of the United States Government or any agency thereof or the Regents of the University of California.

Energy Efficient Indoor VOC Air Cleaning with Activated Carbon Fiber (ACF) Filters

Meera A. Sidheswaran, Hugo Destailats, Douglas P. Sullivan, Sebastian Cohn, and William J. Fisk,

July 2011

Environmental Energy Technologies Division
Indoor Environment Department
Lawrence Berkeley National Laboratory
Berkeley, CA 94720

This work was supported by the Assistant Secretary for Energy Efficiency and Renewable Energy, Building Technologies Program of the U.S. Department of Energy under Contract No. DE-AC02-05CH11231

Energy Efficient Indoor VOC Air Cleaning with Activated Carbon Fiber (ACF) Filters

Meera A. Sidheswaran¹, Hugo Destailats^{1,2,*}, Douglas P. Sullivan¹,
Sebastian Cohn¹, and William J. Fisk¹

1. Lawrence Berkeley National Laboratory, Indoor Environment Department

2. Arizona State University, School of Sustainable Engineering and the Built Environment

** to whom correspondence should be addressed: HDestailats@lbl.gov*

Abstract

This study explores the potential environmental and energy benefits of using activated carbon fiber (ACF) filters for air cleaning in HVAC systems. The parallel aims for the air cleaning system were to enable reduced indoor exposures to volatile organic compounds (VOCs) and to simultaneously allow reduced rates and energy consumption for outdoor-air ventilation. We evaluated the use of ACF media to adsorb VOCs from indoor air during repeated simulated 12-hour to 24-hour periods of occupancy. In a cyclic regeneration process, VOCs were desorbed from the ACF media and vented outdoors to enable the next cycle of air cleaning. The VOC removal efficiency of the ACF media was measured using a 9.5-cm² ACF specimen exposed to a mixture of VOCs that included toluene, benzene, o-xylene, 1-butanol, limonene, undecane and formaldehyde at 29 °C and 30% relative humidity. The concentrations of these model pollutants upstream of the ACF media were in the range 20 to 30 ppb, to simulate realistic conditions. Velocities through the ACF media were typical of those in normal particle filter systems (~0.5 m s⁻¹). Initial tests were conducted to develop a modified multi-component Freundlich isotherm and estimate the maximum adsorption capacity of the media, which was determined to be 90 mg VOC per gram of ACF. Three different ACF regeneration methods were explored using relatively cleaner outdoor air under ambient conditions, with this air humidified, and with the

filter heated. It was found that heating the ACF media to ~ 150 °C by circulation of a DC current through the fibers for a short period (15 minutes) yielded the best VOC removal results, allowing for subsequent consistent removal efficiencies of 70 – 80% for most VOCs. Regeneration with unheated outdoor air was also effective and used less energy (subsequent removal efficiency was 50 – 60% for most VOCs). ACF did not perform as well in eliminating formaldehyde, for which a maximum removal of 25-30% was achieved with heated regeneration. A mass balance model indicated that the combination of ACF air cleaning and a 50% reduction in ventilation will decrease indoor concentrations of VOCs by 60% to 80% and reduce formaldehyde concentrations by 12% to 40%. Energy modeling indicated the potential to reduce the energy required for heating and cooling of ventilation air by 35% to almost 50%.

1 Introduction

Ventilation with outdoor air is required to maintain acceptable concentrations of indoor-generated air pollutants. Analyses of recent modeling indicate that approximately 10% of the energy consumed in the U.S. commercial building stock is used to condition ventilation air (Benne et al. 2009; Griffith et al 2008) provided mechanically and through air leakage. Energy-saving reductions in ventilation rates may be feasible if air cleaning systems can compensate for the diminished rate of pollutant removal by ventilation. For a ~50% reduction in outdoor air ventilation, a volatile organic compound (VOC) removal efficiency of 15 – 20% would be required in the supply airstream of a commercial building heating, ventilating, and air conditioning (HVAC) system that contains 15% to 20% outdoor air and 80% to 85% re-circulated indoor air (Hodgson et al, 2007).

In most commercial buildings, there are few indoor sources of inorganic gaseous pollutants, and the primary indoor-generated airborne pollutants affected by ventilation are particles and VOCs. The existing particle filters in HVAC systems of buildings remove indoor generated particles using far less energy than ventilation. To complement particle filtration, effective and energy efficient air cleaning methods are needed for VOCs. Recent studies have tested granular activated carbon (GAC) filters for VOC removal in non-industrial buildings and have proposed test methods to evaluate the performance of such air cleaning technologies for reduction in ventilation (Bastani et al., 2010; Haghight et al., 2008). Similar to GAC, activated carbon fiber filters (ACF) can be implemented to efficiently remove VOCs from indoor air. Activated carbon fiber (ACF) filters are prepared from fabric precursors and have a very high surface area (specific BET surface area typically higher than $1000 \text{ m}^2 \text{ g}^{-1}$) (Das et al, 2004) and low pressure drop, which make them ideal candidates for use as VOC filters in HVAC systems. Recent studies show that ACF filters are very good VOC adsorbents, showing better performance than granular activated carbon, zeolites and silica gel under identical operation conditions (Das et al, 2004). These filters have a long life time with consistent VOC removal if regenerated periodically. The regeneration process drives previously adsorbed VOCs off the ACF media and exhausts those VOCs outside the building. Liu (1992) found that desorption of

VOCs is very rapid in ACF, as opposed to granular carbon media, and that 90 to 95% of the toluene adsorbed on an ACF system could be successfully desorbed with ambient air in less than two hours, using as regeneration air flow rate a 20% of the air flow rate during air cleaning, temperatures of 7.2 –18.3 °C, and relative humidity of 50 to 80%.

In other studies, effective regeneration of the ACF filter was achieved by direct current (DC) electrical heating (Das et al, 2004; Subrenat and LeCloirec, 2004). Yao et al (2009a, 2009b) suggested that short periods of DC electrical heating of the carbon fibers to 150 or 200 °C is a promising option for periodically regenerating ACF. During the heating period, air flows through the ACF at a lower flow rate and is exhausted outdoors. As an alternative to DC heating of the ACF media, regeneration might be accomplished by passing heated air through the ACF media. However, it is essential to optimize parameters such as duration and frequency of regeneration cycles, the air flow rate and temperature. The ACF system must be energy efficient compared to the traditional ventilation process while still providing sufficient regeneration to enable effective air cleaning during periods of building occupancy.

Although there has been prior research on VOC removal using activated carbon fiber media and media regeneration, these studies were limited to high concentrations of VOCs (parts per million) and were generally targeted towards single compounds. However, to allow a reduction in ventilation rates, an air cleaning system needs to be effective in removing a broad spectrum of VOCs that are present simultaneously in the indoor air at low ppb-level concentrations. In this study we have investigated ACF performance in those realistic conditions, by evaluating the use of such ACF systems to remove a mixture of VOCs from indoor air during work hours, with periodic, e.g., nightly, in-situ regeneration of the carbon fiber media. Regeneration would allow the filter to provide effective VOC air cleaning during the subsequent period of occupancy. We characterized the maximum ACF adsorption capacity and evaluated VOC removal performance for a range of indoor VOCs, with realistic indoor concentrations, over periods that included multiple adsorption-regeneration cycles. Two different regeneration techniques were evaluated to optimize this technology, using heated and unheated outdoor air. Further, a simple mass balance model has been developed to evaluate the performance of ACF filtration in conjunction with a 50% reduction in ventilation under various scenarios. Energy

cost estimation analysis was also performed to assess the energy savings derived from adoption of this technology, compared to the current practice that relies entirely on ventilation.

Figure 1 shows two hypothetical HVAC hardware configurations for VOC air cleaning using ACF filters installed downstream of a particle filter (PF). Such retrofits, involving addition of dampers (D4-D6), a heating system (H), auxiliary fan (F2) and secondary ducts, would allow for periodically regenerating the ACF media by desorbing VOCs from the ACF and venting the desorbed VOCs to outdoors. During periods of air cleaning, air passes through the blue shaded airflow path (HVAC main airflow loop) and VOCs can be removed by adsorption on the ACF filter. Periodically, e.g., each night, the adsorbed VOCs can be removed from the ACF filter by passing a relatively small amount of heated or unheated outdoor air in countercurrent through the ACF filter. Configuration 1 requires less hardware, and configuration 2 avoids passing heated high-VOC regeneration air through the particle filter where some VOCs might adsorb and subsequently be released to indoor air. During regeneration, fan 1 is turned off, fan 2 is turned on, the heater (when used) is turned on, damper D5 (configuration 1) or dampers D5 and D6 (configuration 2) are opened, dampers D2 and D4 are closed (configuration 1) or dampers D2-D4 are closed (configuration 2), and VOCs are desorbed from the activated carbon fiber filter and vented to outdoors.

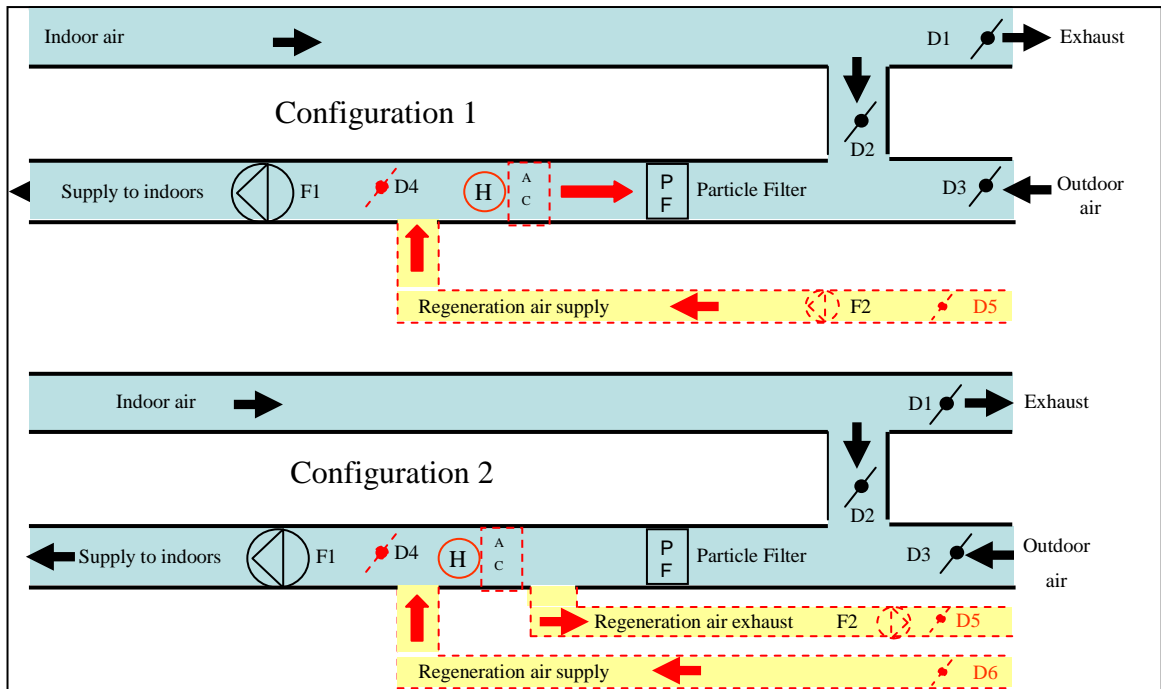

Figure 1. Two possible retrofit configurations using activated carbon fiber air cleaning in a commercial HVAC system*.

* Items in red are added when ACF air cleaning is used. D1 – D6: dampers (D1 – D3 existing HVAC systems); F1: normal supply air fan; F2: added regeneration air fan; PF: normal particle filter; ACF: added activated carbon fiber filter; H: heater

2 Methods

2.1 *Experimental setup*

Experiments were conducted with a 1.4-g single-layer specimen of ACF cloth of 80 mm diameter and 0.4 mm thickness (Calgon Corp., Type FM10) with an exposed area to air flow of 9.5 cm². The properties of the ACF reported by the manufacturer are listed in Table 1. The adsorption and desorption capacities of the ACF were tested using a mixture of VOCs that are commonly present in indoor air. The physical properties and concentrations of the compounds used in the challenge mixture are listed in Table 2. We include reported values for indoor levels in residential and commercial buildings, which are typically in the single-digit ppb range. While individual VOC concentrations are typically ~1 order of magnitude lower than those used in our experiment (except for formaldehyde), the total VOC concentrations in our experiments and in buildings are similar. Additionally although the concentrations of VOCs in this study are lower than the exposure impact limit, prolonged exposures at these levels in indoor settings may trigger building related symptoms. A homogeneous liquid mixture of the target VOCs was prepared and injected at a constant rate using a syringe pump into a 19-m³ stainless steel chamber. The liquid droplets emerging from the syringe evaporated and the gaseous VOCs were dispersed into the chamber at a constant rate (0.2μl min⁻¹) using a blower. Formaldehyde was introduced in aqueous solution using a separate syringe pump with a heated inlet. During one of the initial runs, the formaldehyde source was shutdown to study the effect of absence of formaldehyde on the other VOCs. Also, limonene was added much later in the experiments to include a model compound representing the terpene class of volatiles. The temperature and RH in the chamber were monitored using an APT logging system (Automated Performance Testing, TEC, Minneapolis) and these parameters were maintained at ~29°C and ~30% RH. Ozone-free outdoor air was delivered to the chamber through a GAC filter at an air exchange rate of 1 h⁻¹ that enabled for very low VOC and aldehyde background levels and effectively scrubbed ozone. Chamber air was well mixed using internal fans, and also re-circulated using an external loop fitted with a blower operating at an airflow rate of ~200 m³ h⁻¹, to maintain uniform concentration throughout the chamber. Chamber air used in the experiments was bled through

Teflon tubing connecting to the experimental system shown in Figure 2. Operation of the ACF test system under different regimes is described below.

Table 1. Properties of ACF

Type	Specification	Surface Density ($g\ m^{-2}$)	Thickness (mm)	Surface Area ($m^2\ g^{-1}$)
Zorflex FM 10	1/1 plain weave	120	0.4	1000 - 2000

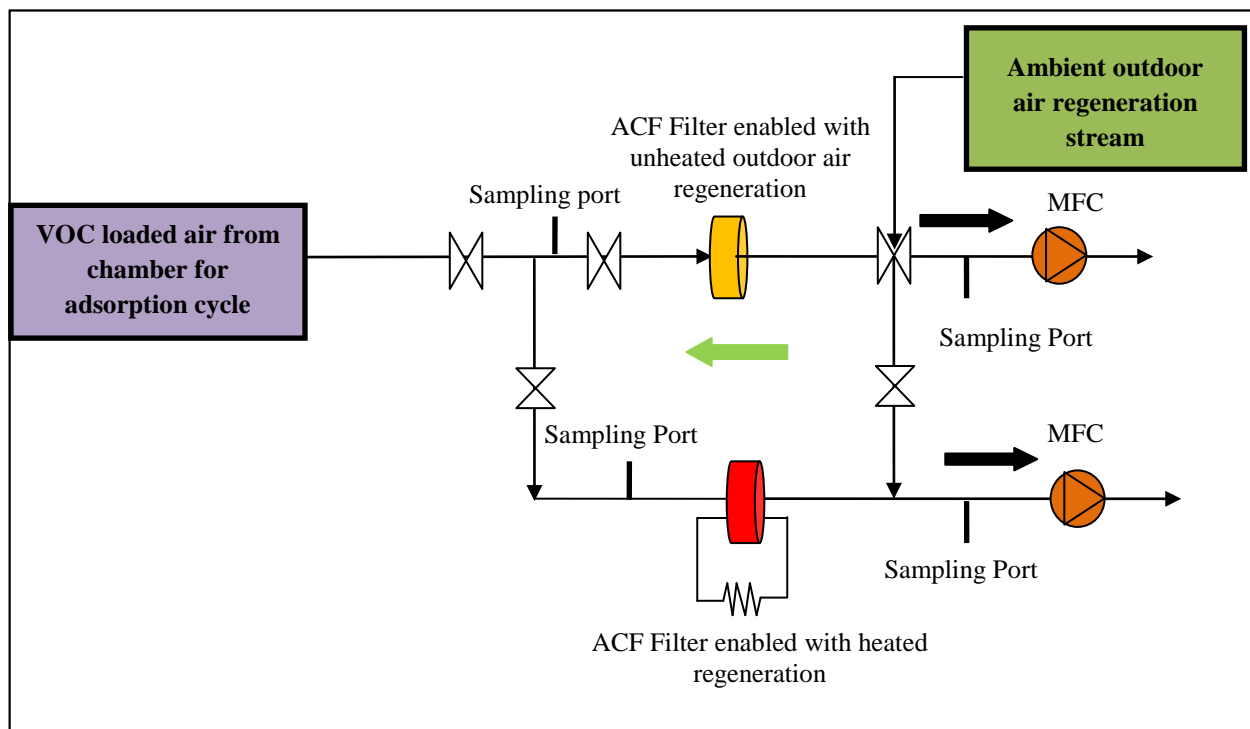

Figure 2. Experimental setup used in this study. The apparatus holding the ACF media was removed, rotated, and reinstalled during regeneration so the the direction of air flow through the ACF during regeneration was opposite the direction of air flow during periods of VOC adsorption.

Table 2. Physical properties, typical indoor levels of selected VOCs and concentrations used in the challenge mixture

<i>Compound</i>	<i>Molecular Weight</i>	<i>Boiling Point (K)</i>	<i>Vapor Pressure (mm Hg)</i>	<i>Reported mean indoor levels (ppb)</i>	<i>Chamber concentration (ppb)</i>
<i>Benzene</i>	78	353	100	0.9 – 3.2 ^(a,b,c)	12 – 15
<i>1-Butanol</i>	74	391	8.8	n.d.	14 - 20
<i>Toluene</i>	92	384	28.4	3.3 – 12 ^(a)	40 – 50
<i>o-Xylene</i>	106	418	6.7	0.5 – 1.8 ^(a)	5 - 10
<i>Undecane</i>	156	469	0.41	n.d.	35 - 40
<i>Limonene</i>	136	449	20	1.4 ^(c)	2-10
<i>Formaldehyde</i>	30	252	(gas at room T)	17 ^(a)	15-30

(a) Hodgson and Levin, 2003; (b) Shimer et al, 2005; (c) Offermann, 2009; n.d.: no data available

2.2 Adsorption (air cleaning) Period

The ACF filter was subjected to a 24-h or a 12-h VOC adsorption period followed by a shorter desorption (regeneration) period. The adsorption period simulates a stage of air cleaning of similar length in an occupied building, and the regeneration period simulates the stage in which VOCs are removed from the ACF media and vented outside, making the ACF ready for the subsequent air-cleaning cycle. The air flows through the ACF were controlled using mass flow controllers (MCR-50SLPM-D/5M, DS, Alicat Scientific) and were maintained to provide a $31.4 \pm 0.1 \text{ m min}^{-1}$ face velocity during the adsorption period. This face velocity is typical of the velocity expected in a real-world application of ACF media as a pleated filter in a filter bank within the supply airstream of HVAC systems.

In order to avoid VOC contamination during experiments, the mass flow controllers were placed downstream of the ACF filters, and vacuum was applied to draw VOC-laden air from the chamber through the ACF filters (Figure 2). Initial tests were performed to obtain the maximum

VOC adsorption capacity of the ACF media. The media was subject to a continuous adsorption period lasting ~ 100 hours and the resulting data allowed an estimation of the adsorption capacity and determination of parameters corresponding to a modified multi-component Freundlich isotherm for the different VOCs on the surface of ACF. Subsequent to these adsorption capacity studies, alternating adsorption and desorption studies were conducted to evaluate the performance efficiency of the ACF media. The details of experimental conditions for these experiments, and for experiments described subsequently, are given in Table S-1 (supporting information).

An adsorption and regeneration cycle is defined as one adsorption period of the ACF and one regeneration period following the adsorption period. Hence Cycle i represents the i^{th} adsorption phase and subsequent i^{th} regeneration phase that follows the adsorption phase. Periods of 24 and 12 hours were used for the adsorption period and different types of ambient air and heated media regeneration techniques were studied. To measure the VOC removal efficiency of the ACF, simultaneous air/VOC samples were collected upstream and downstream of the ACF filter. Samples for VOCs (except formaldehyde) were collected periodically on Tenax-Carbosieve sorbent tubes using a peristaltic pump for a period of 1 hour at the rate of $\sim 30 \text{ mL min}^{-1}$. The samples were analyzed using a gas chromatography system (HP 6890 series GC) with mass selective detector (HP 5973) equipped with a Gerstel TDSA2 thermal desorption inlet with autosampler. Quantification was carried out using bromofluorobenzene as internal standard, with calibration curves using authentic standards. Aldehyde sampling was also conducted periodically on DNPH cartridges (Waters Sep-Pak, # WAT047205) using a peristaltic pump operating at $\sim 1 \text{ L min}^{-1}$ for a duration of 1 hour. DNPH cartridges were extracted with 2-mL aliquots acetonitrile, and the extracts were analyzed by HPLC with UV detection at $\lambda_{\text{max}} = 360 \text{ nm}$ (Agilent 1200). From repeated quality control protocols developed in the laboratory, error in concentration estimations of volatiles has been established to below 10%. Additionally, all samples were duplicated to ensure repeatability and the values reported here is the average. The error bars reported are the absolute difference between the duplicate data points. A calibration curve for quantification was carried out using authentic standards of the dinitrophenyl hydrazone of formaldehyde.

2.3 Regeneration Period

Two different modes of ACF regeneration were evaluated:

2.3.1 Unheated outdoor air regeneration

Unheated outdoor air was passed through the ACF filter after the completion of an adsorption period. Two different air face velocities (6.28 m min^{-1} and 0.31 m min^{-1}) were utilized. The direction of the regeneration air flow was opposite to that of the adsorption air flow. Periodic Tenax and aldehyde samples were collected upstream and downstream of the ACF media and analyzed by methods described above. Electro-thermal regeneration

The electro-thermal regenerative unit was created by clamping the activated carbon cloth between two Teflon flanges. The mating surfaces of the flanges were covered with electrical grade copper sheets in such a way that a voltage could be maintained across the ACF cloth. A Powerstat variable autotransformer, (Type 3PN116C, Superior Electric Co.) was used to apply the desired potential difference across the copper sheets. Temperature on the surface of the ACF media was monitored and recorded using a thermocouple data logger (Extech Easy View 15). The voltage was measured with a multimeter (Keithley 177 Microvolt DMM) and the current across the cloth was measured with an amp meter. The ACF was heated to $\sim 150 \text{ }^\circ\text{C}$ for all of the electro-thermal regeneration tests. Three different face velocities (5.24 m min^{-1} , 0.52 m min^{-1} and 0.11 m min^{-1}) were explored to identify the optimum conditions to achieve high regeneration efficiency with minimal energy consumption. Effect of Relative Humidity on Adsorption and Regeneration

Additional experiments were carried out at 75% relative humidity to evaluate the effect of humidity on adsorption and regeneration of the ACF. All of the adsorption tests (face velocity of 31.4 m min^{-1}) with 75% humidity were conducted for a period of 12 hours followed by a short heated regeneration for 15 minutes at 0.52 m min^{-1} at $150 \text{ }^\circ\text{C}$. Upstream and downstream VOC samples were collected at the end of 12 hours to evaluate the effect of humidity on adsorption capabilities of the carbon fiber in the presence of humidity.

To evaluate the effect and explore the option of using humidity to effectively regenerate the ACF, regeneration experiments were carried out with saturated humid air. The 12 hour adsorption period for these tests was maintained at the ambient air level humidity conditions of 20 – 40%. The regeneration was conducted for a period of 6 hours at > 75% RH at room temperature at a face velocity of 6.28 m min⁻¹. VOC samples were collected during the adsorption cycle to evaluate the effect of humid air regeneration on the adsorption capabilities of ACF.

2.4 Determination of removal and regeneration efficiencies

The VOC percent removal efficiency of a given cycle, $\eta_{a,i}$ was calculated as indicated in equation 1. The regeneration efficiency of a given cycle $\eta_{r,i}$ was calculated as the ratio of the mass of VOC desorbed during a regeneration run to the net mass of VOC accumulated on the ACF from all of the previous adsorption periods using equations 2a and 2b. The average mass accumulated $m_{a,i}$ or removed $m_{r,i}$ during a single adsorption / regeneration period was calculated using equations 3a and 3b.

$$\eta_{a,i} = \left[\frac{C_{0,i} - \overline{C_{a,i}}(t)}{C_{0,i}} \right] \times 100\% \quad (1)$$

$$\eta_{r,i} = \frac{M_{r,i}}{M_{a,i}} \quad (2a)$$

$$M_{a,i} = \sum_{k=1}^i m_{a,k} - \sum_{k=1}^{i-1} m_{r,k} \quad (2b)$$

$$M_{r,i} = \sum_{k=1}^{i-1} m_{r,k} \quad (2c)$$

$$m_{a,k} = \int_0^t (C_{0,k} - C_{a,k}(t)) Q_a dt \quad (3a)$$

$$m_{r,k} = \int_0^t (C_{r,k}(t)) Q_r dt \quad (3b)$$

where, $\eta_{a,i}$ is the percent removal efficiency, $\eta_{r,i}$ is the regeneration efficiency, $M_{r,i}$ is the mass of VOC desorbed at the end of the i^{th} regeneration period (ng), $M_{a,i}$ is the total mass of the VOC adsorbed in the ACF filter at the end of the i^{th} adsorption period (ng). $C_{0,k}$ is the inlet concentration of the k^{th} adsorption period of the VOC under study (ng m^{-3}), $C_{a,k}$ is the outlet concentration obtained downstream of the filter during the k^{th} adsorption period (ng m^{-3}), Q_a is the adsorption air flow rate ($m^3 s^{-1}$), $m_{a,k}$ is the mass of VOC adsorbed in the ACF filter during the k^{th} adsorption period (ng). $C_{r,k}$ is the outlet concentration obtained downstream of the filter during the k^{th} regeneration period (ng m^{-3}), Q_r is the regeneration air flow rate ($m^3 s^{-1}$), and $m_{r,k}$ is the mass desorbed during the k^{th} regeneration period (ng).

3 Results

3.1 Modified multi-component adsorption isotherm and VOC holding capacity of ACF

A Freundlich multi-component isotherm model (Sheindorf et al., 1981) was adopted to develop an approximate isotherm for the different VOCs. There are numerous studies (Cal., et al, 1997, Singh et al., 2002, Ramirez et al., 2005, Yao et al., 2009c) that have modeled a single component adsorption isotherm for activated carbon; however, very little research has been performed on the modeling of multi-component interaction on ACF cloth. Yao et al., 2009 have developed isotherms for toluene adsorption and modeled the mono-component adsorption parameters. The multi-component adsorption isotherm expressed in terms of sorbate mass as described by Sheindorf et al., 1981 is written as follows:

$$q_i = K_i C_i \left(\sum_{j=1}^k a_{ij} C_j \right)^{n_i-1}, \quad (4)$$

where q_i is the maximum adsorbed mass of component i per unit mass of media (expressed in $\mu\text{g g}^{-1}$), K_i is the mono-component Freundlich adsorption constant for the component i , $a_{i,j}$ are dimensionless adsorption competition coefficients for multi-component system which is equal to unity when $i=j$ ($a_{i,i}=1$), n_i is the isotherm exponent of the component i , C_j is the concentration of the component j , and k is the total number of components in the system. This model is valid only for compounds where the mono-component adsorption Freundlich isotherm is applicable.

The dimensionless adsorption breakthrough profile for the VOC mixture studied in this work is shown in the supporting information document (Figure S-1). The experiments were conducted at the adsorption face velocity of 31.4 m min^{-1} and samples were collected periodically. The saturation time was estimated to be $\sim 97\text{h}$. Since we performed a continuous flow experiment to determine the bed life, the off-gassing of VOCs was observed in subsequent measurements leading to values higher than 1 for $C_{a,i}/C_{0,i}$ as shown in Figure S-1. The breakthrough period reported here is lower than the breakthrough values reported by Yao et al., (2009) and Das et al., (2004). Both these studies were accomplished with single component adsorption, at different flow velocities with different adsorbent mass and the concentration ranges studied by the latter are in the high ppm range, at least 3 orders of magnitude higher than our study. The isotherm parameter n in case of single component Freundlich model tends to increase with increase in concentration levels of the adsorbate (Yao et al., 2009, Das et al., 2004, Cal et al., 1997). The exponential n values of the VOCs obtained from the multi-component modeling in this study are different from the n values predicted by Yao et al., (2009) for a single component model. The lower saturation period and different isotherm parameters obtained in this study may be due to the behavior of the mixture of VOCs on the ACF surface leading to competitive adsorption. However, the maximum total VOC adsorption capacity obtained from this study are in agreement with the study by Yao et al., 2009 in which they show integrated adsorption of 81.6 mg of toluene per gram of ACF over a saturation period of 197 hours as opposed to 90.7 mg of VOC mixture per g of ACF obtained in this study.

The maximum adsorption capacity of the ACF cloth for the compounds under study, under the experimental conditions employed, was determined experimentally by integrating the area under the adsorption concentration profile for each compound. The values were estimated to

be 3.1, 4.8, 24.2, 7.8, 48.2, and 2.6 mg g⁻¹ for benzene, 1-butanol, toluene, o-xylene, undecane and formaldehyde respectively (total VOC mass accumulated = 90.7 mg g⁻¹). These experimental values are in agreement with the values predicted by the isotherm developed in this study and are within the 95% confidence interval.

The parameter estimation for the modified multi-component Freundlich isotherm involved solving multi-variable linear equations simultaneously and reiterating the estimated parameters to ensure convergence. The adsorption constant K_i for the different compounds under study was either obtained from or determined by methods listed by Yao et al., 2009. After every iteration, the $a_{i,j}$ values were substituted in equation 4 and K_i value was back calculated. This process was repeated until the error difference of the predicted K_i from Yao et al., and the K_i value back calculated from our $a_{i,j}$ values was less than 0.001. The isotherm parameters estimated for benzene, 1-butanol, o-xylene, toluene, undecane and formaldehyde are listed in Table S-2 (Supporting Information). The adsorption capacity for the challenge mixture, evaluated to be 90.7 mg g⁻¹, is close to the K_i estimated for 1-butanol (92.3 mg g⁻¹) and toluene (123 mg g⁻¹); it is much higher than the parameters estimated for the two more volatile constituents, benzene (7.6 mg g⁻¹) and formaldehyde (1.8 mg g⁻¹); and it is significantly lower than K_i estimated for the constituents with higher tendency to adsorb to the carbon matrix, o-xylene (259 mg g⁻¹) and undecane (454 mg g⁻¹).

One of the main aims of this isotherm study is to determine the bed life, i.e., the time before the ACF bed becomes saturated and will no longer remove VOCs. Bed life (T_B) can be defined as follows (Yao et al., 2009):

$$T_B = \frac{M_{ACF}}{Q} \left(\sum_i \frac{q_i}{C_{i,in}} \right) \quad (5)$$

where, M_{ACF} is the mass of activated carbon fiber (g), Q is the flow rate of the air stream to be treated (L min⁻¹), $C_{i,in}$ is the inlet concentration of the component i of the multi-component VOC stream ($\mu\text{g L}^{-1}$). Hence, we could verify the consistency of the experimental results by estimating the bed life of a mass of 1 g of ACF used to remove benzene, butanol, toluene, xylene, undecane and formaldehyde at average concentrations of 4 $\mu\text{g m}^{-3}$, with an air flow of 1.8 m^{3 h}⁻¹ through

the ACF from equation 1-5. For these conditions the estimated bed life is approximately 103 hrs, which is consistent with the values estimated from the experiments. The replacement of the ACF media every 103 hours of operation is impractical, and hence periodic in-situ regeneration is necessary for this scenario.

3.2 Evaluation of VOC air cleaning with different regeneration methods

3.2.1 Adsorption – Regeneration cycles: Method I – Regeneration with room temperature outdoor air

ACF performance using two different regeneration flow rates with outdoor air was evaluated to identify the optimum method for efficient VOC removal from supply air. New ACF media was saturated initially based on bed life (equation 5) estimates from section 3.1 and regenerated for a period of 12 hours before subjecting it to alternate adsorption and regeneration phases.

3.2.1.1. Regeneration with outdoor air at 6.28 m min^{-1}

Figure 3 shows the VOC removal efficiency achieved for different cycles for different VOCs in the mixture with an adsorption period face velocity of 31.4 m min^{-1} . The levels of the VOCs in this study were maintained below 50 ppb. It was found that the ACF had a removal efficiency of 40 – 70% in the first cycle, which decreased to 20 – 45% in the subsequent cycles. All of the adsorption-regeneration cycles studied with a 6.28 m min^{-1} regeneration air velocity for a period of 12 hours are not shown in the Figures 3 (a) – (f) to eliminate overlap of data points for a clear demonstration. Limonene was added to the VOC mixture in cycles 6 – 12 and showed an average removal efficiency of ~ 35%. Formaldehyde was not present in adsorption period 4 and it was found that there was a very high initial adsorption of > 90% for all of the VOCs, thus suggesting a significant competitive effect even for compounds with very low K_i during an initial transient period. However, by the end of a 24-h cycle, the removal efficiency for all compounds decreased to values that are comparable to the other cycles (in the presence of formaldehyde). Table 3 lists the regeneration efficiency $\eta_{r,i}$ (as estimated from equation 2a) obtained for various VOCs for the different adsorption – regeneration cycles. The regeneration efficiency increased in the second cycle and decreased subsequently. We speculated that this behavior may be explained

by strong initial adsorption of the volatiles as a monolayer on the ACF surface and weaker multilayer adsorption of additional volatiles. The regeneration process does not remove all of the adsorbed VOCs, thus, as the amount of the VOCs retained on the ACF increased, the VOC amount removed by the cloth from the inlet stream decreased, leading to lower VOC removal efficiency (Figure 3). The regeneration efficiency increases in the second cycle (Table 3) due to ease of desorption of multi-layer VOCs that are not in direct contact with the ACF surfaces. As the surface adsorption reaches steady state, subsequent cycles show lower regeneration efficiency, as shown in Table 3.

Table 3. Regeneration efficiency $\eta_{r,i}$ (as estimated from equation 2a) for different compounds using room temperature outdoor air for regeneration (face velocity during regeneration = 6.3 m min⁻¹).

<i>Compound</i>	<i>Cycle 1</i>	<i>Cycle 2</i>	<i>Cycle 3</i>	<i>Cycle 4</i>	<i>Cycle 5</i>
<i>Benzene</i>	0.05	0.76	0.13	0.19	0.12
<i>Butanol</i>	0.03	0.11	0.12	0.15	0.30
<i>Toluene</i>	0.01	0.40	0.30	0.12	0.28
<i>O-xylene</i>	0.10	0.73	0.32	0.17	0.11
<i>Undecane</i>	0.04	0.22	0.20	0.11	0.08
<i>Formaldehyde</i>	0.05	0.56	0.04	0.01	0.54

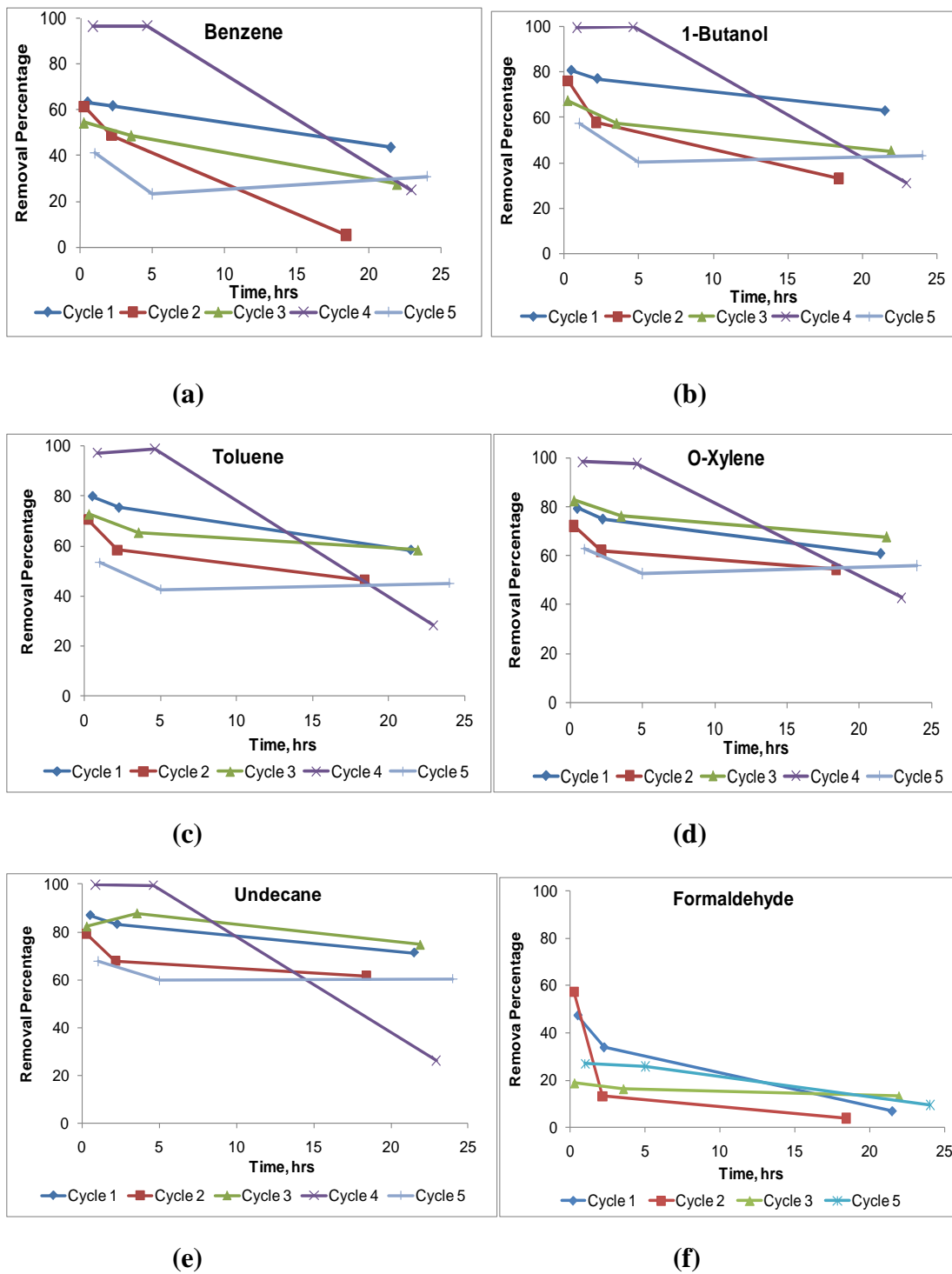

Figure 3. Removal efficiency time profile for (a) benzene, (b) 1-butanol, (c) toluene, (d) o-xylene, (e) undecane, (f) formaldehyde for different adsorption – regeneration cycles with adsorption face velocity of 31.3 m min^{-1} and regeneration face velocity of 6.3 m min^{-1}

3.2.1.2. Regeneration with outdoor air at 0.31 m min⁻¹ face velocity

Additional experiments after 12 cycles with outdoor air regeneration at 6.3 m min⁻¹ were performed to test the efficiency of regeneration using a much lower air flow. The ACF cloth was regenerated for 53 hours using the same air face velocity of 6.3 m min⁻¹ prior to additional testing. The additional adsorption experiments of 24 hours duration were followed by regeneration with face velocities of 0.3 m min⁻¹ over periods of 12 hours. These cycles are named as Cycle' to distinguish from the cycles with a regeneration face velocity of 6.3 m min⁻¹. Cycle'1 follows the 53 hour regeneration after Cycle 12 of the regeneration system discussed above (at 6.3 m min⁻¹). The adsorption of more sorptive species improved significantly when preceded by the prolonged regeneration time (Cycle'1). Subsequently, the regeneration efficiency decreased rapidly and breakthrough (release of VOCs by the ACF media during the air cleaning cycle) was achieved at the end of cycle '3 for most constituents, and at the end of cycle'4 for the less volatile constituents (limonene and undecane). These results show that decreasing the regeneration airflow rate decreased the subsequent VOC removal efficiency to an unacceptable level (Figure 4).

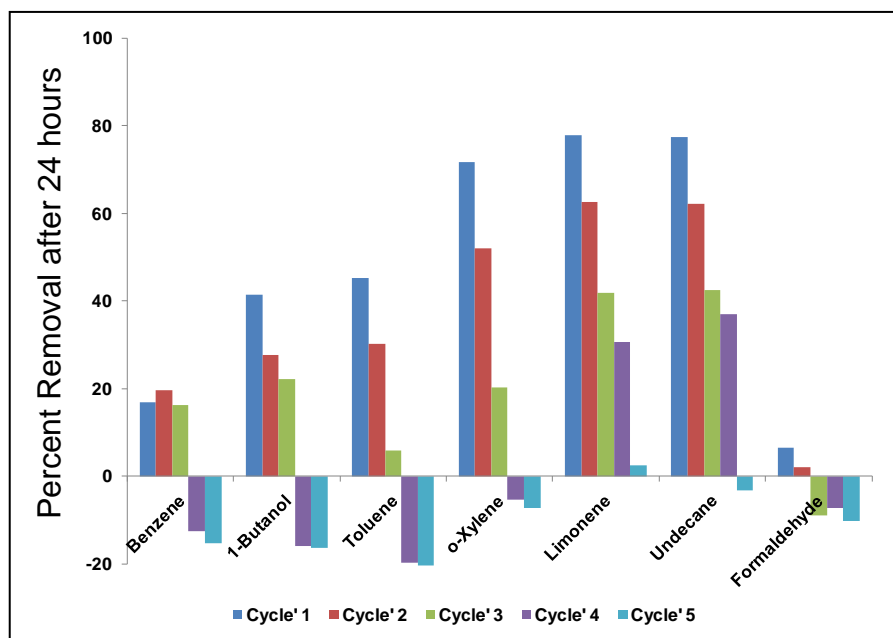

Figure 4. VOC removal efficiency for 24 hour adsorption period with a room temperature outdoor air regeneration face velocity of 0.3 m min^{-1} for 12 hours. Negative values indicate downstream levels higher than upstream concentrations due to ACF saturation.

3.2.2 Adsorption – Regeneration cycles: Method 2- Regeneration with electro-thermal heating of ACF cloth

The electro-thermal regeneration method has been explored in a number of studies to obtain optimal loading and regeneration conditions for ACF fiber systems (Yao et al., 2009, Sullivan et al., 2001, Dombrowski et al., 2004). These studies utilized a single VOC at different concentrations. Our study concentrates on optimizing electro-thermal regeneration process for multi-VOC system to obtain an ACF system with maximum energy efficiency.

The adsorption period face velocity of the polluted air stream was maintained at 31.4 m min^{-1} for all of these experiments. The temperature of the ACF fiber during regeneration was maintained at $150 \text{ }^\circ\text{C}$ for 2 hours and the regeneration air flow rates were varied. In the heated regeneration phase, three face velocities of 5.24 , 0.52 and 0.11 m min^{-1} were studied to determine the optimum regeneration efficiency. Figure 5 shows the VOC percent removal efficiency for different adsorption-regeneration cycles. The three flow regimes are marked on the plot in Figure 5. The regeneration face velocity of 5.24 m min^{-1} was maintained for Cycles 1 – 4. The regeneration face velocity of 0.52 m min^{-1} was maintained for Cycles 5 – 7 and the regeneration face velocity of 0.11 m min^{-1} was maintained for Cycles 8 – 12.

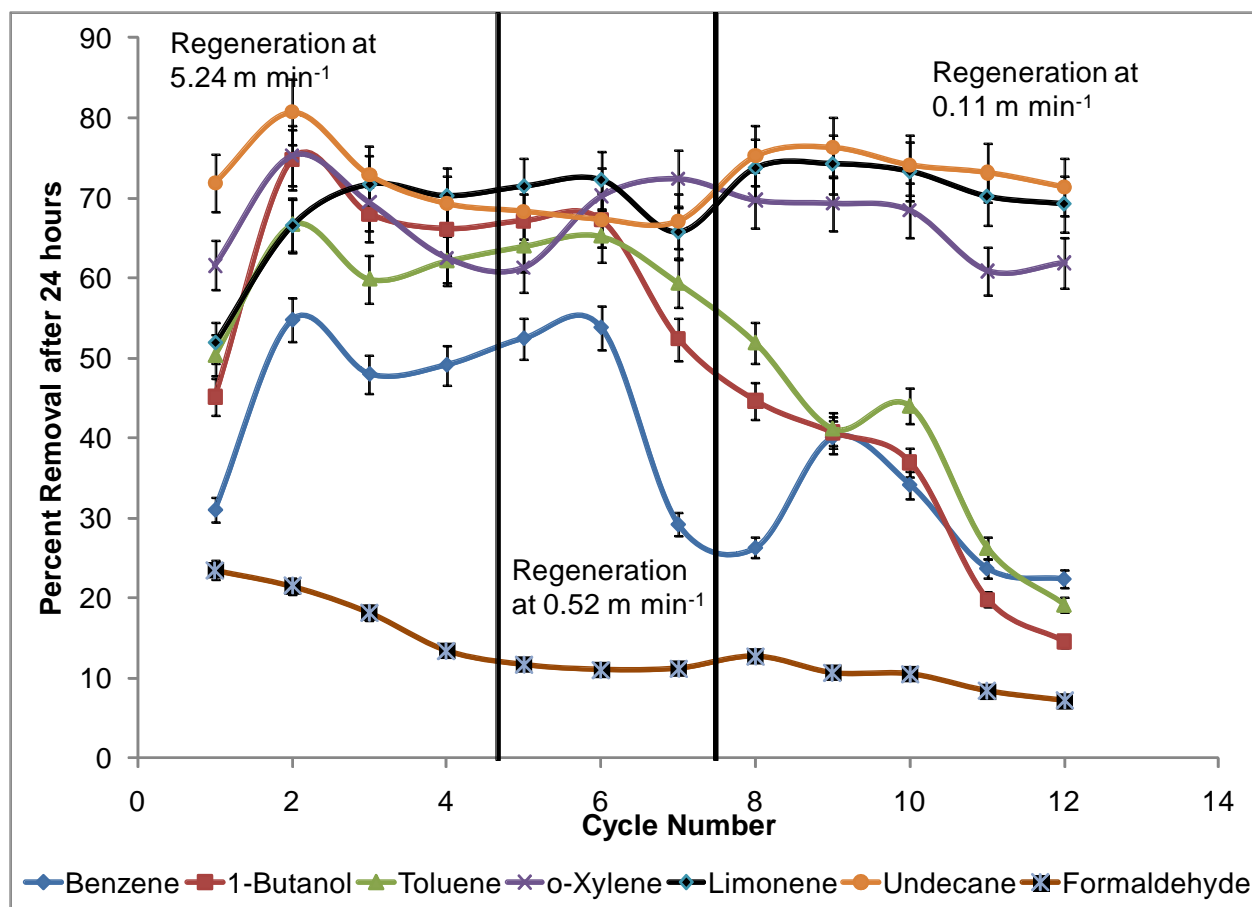

Figure 5. VOC percent removal efficiency for a 24-h adsorption period with different electro-thermal regeneration air stream face velocities and a regeneration temperature of 150 °C for two hours.

Different percent removal efficiencies were observed for different VOCs for regeneration face velocities using the electro-thermal regeneration method. The percent removal of formaldehyde decreased consistently for regeneration cycles with low face velocities. For compounds such as benzene, 1-butanol and toluene, with relatively weaker adsorption to ACF, the percent removal efficiency decreased with decrease in regeneration flow. Instead, o-Xylene, limonene and undecane showed a consistent performance with high and almost constant removal efficiency for each cycle (~62%, 71% and 74%, respectively). These three compounds have a high Freundlich adsorption capacity constant (K_i) (Table 3) compared to formaldehyde, benzene, toluene and 1-butanol. These compounds can adsorb strongly on the carbon fiber surface and

displace the more volatile species (e.g., benzene and toluene), leading to a decreased percent removal efficiency as shown in Figure 5. Removal of formaldehyde is consistently lower for all regeneration conditions. The regeneration efficiency of the electro-thermal desorption system was studied for 5.2 m min^{-1} and 0.52 m min^{-1} regeneration velocities and the results are listed in Table 4. The regeneration efficiency depended on the flow rate of the regeneration stream, very similar to the results found in Method I discussed above.

Table 4. Regeneration efficiency $\eta_{r,i}$ of different compounds under different face velocities using electro-thermal regeneration at $150 \text{ }^\circ\text{C}$ for two hours.

<i>Compound</i>	<i>Regeneration Face Velocity</i>						
	<i>5.2 m min⁻¹</i>				<i>0.52 m min⁻¹</i>		
	<i>Cycle 1</i>	<i>Cycle 2</i>	<i>Cycle 3</i>	<i>Cycle 4</i>	<i>Cycle 5</i>	<i>Cycle 6</i>	<i>Cycle 7</i>
<i>Benzene</i>	0.41	0.42	0.43	0.44	0.45	0.36	0.31
<i>Butanol</i>	0.61	0.62	0.64	0.65	0.66	0.42	0.36
<i>Toluene</i>	0.64	0.61	0.58	0.55	0.52	0.45	0.37
<i>o-Xylene</i>	0.85	0.83	0.81	0.79	0.68	0.58	0.59
<i>Undecane</i>	0.86	0.84	0.82	0.84	0.68	0.57	0.55
<i>Limonene</i>	0.88	0.84	0.84	0.84	0.71	0.70	0.72
<i>Formaldehyde</i>	0.87	0.83	0.80	0.76	0.73	0.70	0.68

3.2.3 Adsorption – regeneration cycles: Methods 1 and 2 with shorter adsorption (air cleaning) cycles

3.2.3.1. Shorter Adsorption and Regeneration Cycles

One main aim of this project was to identify an optimum cycle to implement ACF filter system to remove VOCs in HVAC units as energy retrofit in office buildings. For this purpose,

we studied shorter adsorption and regeneration periods. The duration of the adsorption period was reduced from 24 hours to 12 hours. In a building with only work-day occupancy, periods of HVAC operation may be close to approximately 12 hours. Both outdoor ambient air regeneration and electro-thermal regeneration were studied with 12 hours adsorption periods. The outdoor air regeneration was carried out at air face velocities of 4.2 m min^{-1} for duration of 6 hours and the electro-thermal regeneration by heating the ACF cloth at $150 \text{ }^{\circ}\text{C}$ was carried out at air face velocities of 1.1 m min^{-1} for a duration of 15 minutes.

3.2.3.2. Regeneration with outdoor air at a face velocity of 4.2 m min^{-1}

Figure 6(A) shows the VOC percent removal efficiency for 12-h adsorption periods with unheated outdoor air regeneration. It was found that the ACF filter had a relatively consistent removal efficiency for all of the VOCs studied. The formaldehyde removal was low ($\sim 16\%$), but at the lower bound of the 15% to 20% target needed to compensate for a 50% reduction in outdoor air. The VOC removal efficiencies at the end of 12 hour cycles were much higher than the VOC removal efficiency observed for 24-h cycles.

3.2.3.3. Electro-thermal regeneration at a face velocity of 1.1 m min^{-1}

Figure 6(B) shows VOC percent removal efficiency obtained at the end of 12 hours with electro-thermal regeneration. The VOC removal efficiency was higher than that observed at the end of 24 hours with a comparable regeneration flow rate. Further, the removal efficiency was also consistent for all of the VOCs studied, in contrast to the prior findings (Figure 4) where the removal efficiency decreased to a minimum at the end of 24 hours. The formaldehyde removal efficiency was low but met the the 15% to 20% target. The duration of regeneration was small compared to the duration of regeneration for unheated outdoor ambient air regeneration.

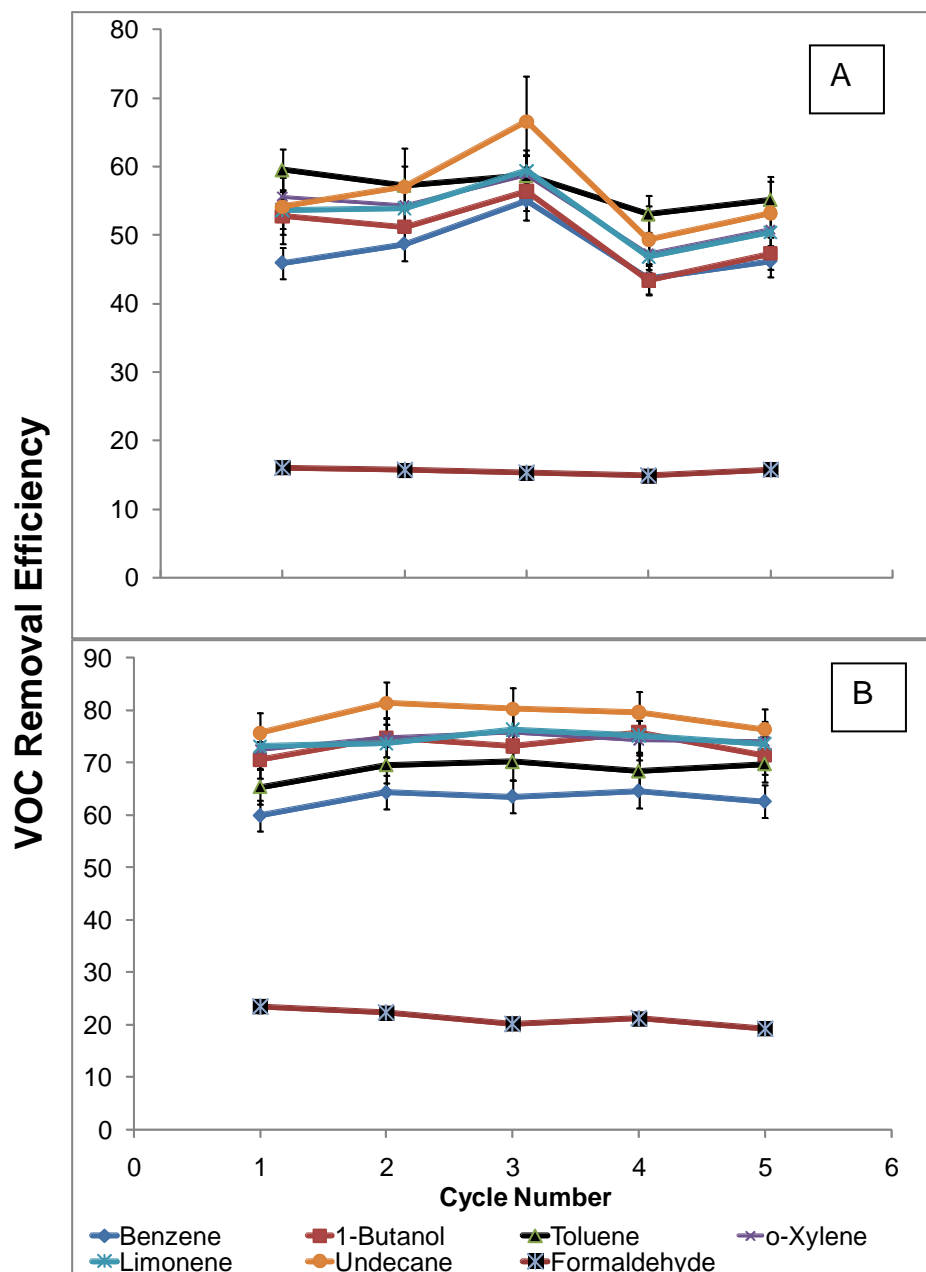

Figure 6. VOC percent removal efficiency for 12 hour adsorption cycle with (A) outdoor air regeneration at 25 °C and air face velocity of 4.2 m min⁻¹ for 6 hours and (B) electro-thermal regeneration at 150 °C and air face velocity of 1.1 m min⁻¹ during 15 minutes

3.3 Effect of high relative humidity on adsorption and regeneration

The results of the adsorption experiments with 75% RH at a face velocity of 31.4 m min⁻¹ and regeneration at 150 °C are presented in Figure S-2 of the supporting information. The percent removal of non polar compounds by the ACF such as benzene decreased by <5% while that of compounds soluble in water such as formaldehyde increased by about 10%. The heated regeneration of the activated carbon was effective in restoring the adsorption properties of the ACF.

Two additional experiments were conducted to explore the possibility of using humidified air as to enhance the regeneration efficiency. Results obtained were not encouraging, and this method was not explored further. A comparison between regeneration using ambient air (RH = 20-40 %) and high humidity conditions (RH = 80 %) is presented in supporting information in Figure S-3.

3.4 Prediction of impacts on indoor VOC levels: Mass balance model

A simple mass balance model (flow diagram shown in Supporting Information, Figure S-4) was developed to analyze the effect of using ACF media to remove VOCs from indoor air. Scenarios with two different initial ventilation rates were studied to predict the performance of ACF when ventilation rates are subsequently reduced. In all scenarios the, volume-normalized supply air flow rate, equal to rate of flow of outdoor air plus recirculated-indoor air through the air cleaner divided by the indoor volume, was 4 h⁻¹. This is a typical volume normalized supply air flow rate in a U.S. commercial building.

3.4.1 Scenario 1: Moderate initial ventilation rates

Base Case: The air handling system operates without an ACF filter bed air cleaning unit, an outdoor air ventilation rate of 0.8 h⁻¹ and a volume-normalized VOC source emission rate of 6.4 ppb h⁻¹ for each VOC.

- Case 1.1: Air handling system with ACF filter bed air cleaning unit with heated outdoor air regeneration and outdoor air ventilation exchange rate of 0.4 h^{-1} (50% reduction in ventilation).
- Case 1.2: ACF filter bed air cleaning unit with unheated outdoor air regeneration and outdoor air ventilation rate of 0.4 h^{-1} (50 % reduction in ventilation).

3.4.2 Scenario 2: High initial ventilation rates

Base Case: The air handling system operates without an ACF filter bed air cleaning unit, at an outdoor air ventilation rate of 1.2 h^{-1} and a volume-normalized VOC source emission rate of 6.4 ppb h^{-1} for each VOC.

- Case 2.1: Air handling system with ACF filter bed air cleaning unit with heated outdoor air regeneration, outdoor air ventilation rate of 0.6 h^{-1} (50% reduction in ventilation).
- Case 2.2: ACF filter bed air cleaning unit with unheated outdoor air regeneration and outdoor air ventilation rate of 0.6 h^{-1} (50 % in ventilation)

The VOC air cleaning effectiveness ratio (R_i) for a given VOC i , is defined as the ratio of the indoor VOC concentration with the ACF filter bed installed in the system to the VOC concentration without the ACF system (equation 6). A lower air cleaning effectiveness ratio denotes a better performing ACF unit. $R_i \leq 1$, signifies that the air cleaning technology maintains a lower indoor VOC concentration than the base case system with twice the ventilation rate. The air cleaning effectiveness ratio can also be calculated from the air exchange rates and VOC removal efficiency of the ACF system as shown in equation 7.

$$R_i = \frac{[C_i]_{ACF}}{[C_i]_{no-ACF}} \quad (6)$$

$$R_i = \frac{[S_r + N_{v,ACF}(1-\eta_i)]N_v}{(N_v + \eta_i(N_r - N_{v,ACF}))(S_r + N_v X_{0,i})} \quad (7)$$

where $[C_i]_{no-ACF}$ is the indoor concentration of the VOC species i with an air handling unit without ACF filter bed, $[C_i]_{ACF}$ is the indoor concentration of the VOC species i with an air

handling unit with an ACF filter bed, S_r is the emission rate source concentration per unit volume, N_r is the volume-normalized supply air flow, N_v is the number of air changes with outdoor air in the scenario without ACF filter bed, N_{v-ACF} is the number of air changes with outdoor air in the scenario with ACF filter bed, $X_{0,i}$ is the concentration of VOC entering from outdoors through ventilation (assumed to be 2 ppb for all our model calculations), and η_i is the percent removal efficiency of the ACF filter system for a given species i .

The removal efficiency of different VOCs tested in our experiments and the corresponding R_i values for different ventilation scenarios and corresponding cases are listed in Table S-3 (Supporting Information). It was observed that in both scenarios of low and high ventilation rates, the system equipped with ACF filter bed and 50% reduced ventilation performed better than the system without ACF filter bed, with $R_i < 1$ (in the range 0.21 – 0.72) in all cases for all VOCs. This was true even in the case of formaldehyde for which the VOC removal percent was significantly lower than for other organic compounds studied in this project ($R_{\text{formaldehyde}} = 0.56$). It was also observed that cases in which ACF was regenerated by heating have lower R_i (in the range 0.21-0.56) values compared to the corresponding cases in which ACF was regenerated with unheated outdoor air (between 0.26 and 0.72). This shows that the heated regeneration method improved ACF VOC removal performance compared to the unheated outdoor air regeneration method.

3.5 Energy consumption associated with the implementation of an ACF filter bed system

The pressure drop across the ACF filter is low (in the range 30 Pa) relative to total supply-airstream pressure drops in commercial air handlers and does not contribute significantly to the overall operational cost of HVAC systems. The main additional operational cost of an ACF filter bed in an HVAC system is the energy required to regenerate the ACF cloth. The energy consumption costs were computed for different regeneration face velocities and temperatures, in order to provide a first-order estimation of energy savings that may be achieved by implementing this technology. Net energy required to regenerate the system was estimated as

a sum of the energy required to heat the ACF cloth, heat the regeneration air passing through the cloth and the energy consumed by a fan to circulate air through the system. The energy consumption and cost estimates for different ratios of adsorption to regeneration face velocity and regeneration temperature are listed in Table 5. For reference, a U.S. average annual ventilation cost in offices was also estimated by analyzing data from Benne et al (2009), Griffith et al. (2009), and Persily and Gorfain (2008). It was estimated that the unheated outdoor air regeneration consumed the least energy. The most realistic condition for optimal operation with heated regeneration would be operating the ACF at 150 °C at regeneration air velocities that are 1/30 of the velocities during air cleaning adsorption periods. With this operational strategy, the annual energy cost estimate for providing a unit of VOC free air with an ACF filter systems is 15% of the estimated U.S. average cost of providing the same amount of VOC removal by ventilation. Thus, with a 50% reduction in outdoor air, total building ventilation energy cost is reduced by approximately 35%. With unheated outdoor air regeneration, which also yielded good VOC control performance, the total building ventilation energy cost is reduced by almost 50%, as the regeneration energy is insignificant. These preliminary energy cost estimates for operating an ACF system show that incorporating the ACF filter bed in a HVAC system can effectively contribute substantially towards reducing ventilation energy consumption.

Table 5. Annual regeneration energy cost estimates for the electro-thermal regeneration system and savings obtained from ventilation costs.

<i>Ratio of adsorption to regeneration face velocity</i>	<i>Regeneration temperature</i> <i>°C</i>	<i>Net energy required to produce 1m³ s⁻¹ of VOC free air per regeneration period</i> <i>(KWH)/(m³s⁻¹)/cycle</i>	<i>Annual regeneration cost per unit rate of VOC free air*</i> <i>(\$/m³s⁻¹)</i>	<i>Annual Ventilation cost per unit rate of VOC free air</i> <i>(\$/m³s⁻¹)</i>
300	150	0.35	9	389
	200	0.48	13	389
30	150	2.15	56	389
	200	2.99	78	389
6	20	0.22	6	389
	150	10.4	270	389
	200	14.3	371	389

* Assumes 260 regenerations in a year

4 Summary and Conclusions

The ACF system has been studied for a mixture of typical indoor VOCs, and the results indicate that this is a very promising technology. ACF cloth media has a long adsorption life time and can be effectively used for removing indoor VOCs with periodic regeneration. The adsorption isotherms of the studied VOCs onto the ACF cloth suggest that it will take about ~100 hours to fully saturate the ACF media when challenged with air containing realistic concentrations of a range of indoor VOCs. The results from periodic adsorption and desorption experiments show that the ACF media can be easily regenerated after a 12 or 24 hour period of air cleaning. Additional studies are needed to establish the effect of oxidants such as ozone, optimal regeneration conditions, system lifetime and overall costs. Currently efforts are being taken to study the effect of ozone on the ACF system. Studies by Gundel et al., (2002) show that ozone can be effectively removed by using carbon based air cleaning systems. Lee and

Davidson, (1999) showed that ozone can react and destroy the structural properties of ACF leading to lower performance. However the material tested is different from the material used in this study and the regeneration methods considered in their study was ineffective. Hence it is very difficult to generalize the detrimental effect of ozone on ACF performance based on limited available evidence.

Our experiments also showed that regeneration of the ACF media at 150 °C proved to be effective in improving the VOC air cleaning efficiency relative to regeneration with unheated outdoor air. While regeneration was better with the heated media, results with unheated ACF were also very acceptable, suggesting that an optimal usage of ACF may not necessarily include a heating phase on every cycle. Instead, periodic heating after a (relatively large) number of cycles may be sufficient to remove strongly-adsorbed species that otherwise would buildup under room temperature operation. The VOC removal efficiencies were increased when the adsorption time was reduced to 12 hours from 24 hours. A mass balance model shows that an HVAC system equipped with an ACF filter bed, with either unheated or heated outdoor air regeneration, can reduce indoor VOC concentrations even when ventilation rates are reduced by 50%. Calculations indicated that reducing ventilation rates by 50% and using of ACF air cleaning with heated or unheated outdoor air will result in substantial energy savings.

Acknowledgments

This work was supported by the Assistant Secretary for Energy Efficiency and Renewable Energy, Building Technologies Program of the U.S. Department of Energy under Contract No. DE-AC02-05CH11231. The authors thank Jerome Lam, Colin McCormick and Joe Hagerman of DOE for program management, R. Maddalena, M. Sleiman, M. Russell, T. Hotchi, and A. Montalbano for technical assistance, and L. Gundel and M. Apte for reviewing a report on which this paper is based.

References

- Bastani, A., Lee, C-S, Haghghat, F., Flaherty, C. and Lakdawala, N. Assessing the performance of air cleaning devices – A full-scale test method. *Building and Environment* 2010, 45, 143-149.
- Benne, K., Griffith, B., Long, N., Torcellini, P. Assessment of the energy impacts of outside air in the commercial sector. NREL/TP-550-41955. Golden, CO, National Renewable Energy Laboratory, 2009.
- Das, D., Gaur, V and Verma, N. Removal of volatile organic compound by activated carbon fiber. *Carbon* 2004, 42(14): 2949-2962.
- Dombrowski, K. D., Lehmann, C. M. B., Sullivan, P. D., Ramirez, D., Rood M. J., and Hay K. J. Organic vapor recovery and energy efficiency during electric regeneration of an activated carbon fiber cloth adsorber. *Journal of Environmental Engineering-ASCE* 2004, 130(3): 268-275.
- Cal, M.P., Rood, M.J., Larson, S.M. Gas Phase Adsorption of Volatile Organic Compounds and Water Vapor on Activated Carbon Cloth; *Energy Fuels* 1997, 11, 311-315.
- Fisk, W. J. Can sorbent-based gas phase air cleaning for VOCs substitute for ventilation in commercial buildings?. *Proceedings of the IAQ 2007 Healthy and Sustainable Buildings*. ASHRAE, Atlanta, 2007.
- Griffith, B., Long, N., Torcellini, P. and Judkoff, R. Methodology for modeling building energy performance across the commercial sector, . NREL/TP-550-41956. Golden, Co. National Renewable Energy Laboratory, 2008.
- Gundel, L., Sullivan, D. P., Katsapov, G. Y., Fisk, W. J. A Pilot Study of Energy Efficient Air Cleaning for Ozone, Report LBNL-51836, Lawrence Berkeley National Laboratory, 2002.
- Haghghat, F., Lee, C-S., Pant, B., Bolourani, G., Lakdawala, N., Bastani, A. Evaluation of various activated carbons for air cleaning – Towards design of immune and sustainable buildings. *Atmos. Environ.* 2008, 42, 8176-8184.
- Hodgson, A.T. and Levin, H. Classification of measured indoor volatile organic compounds based on noncancer health and comfort considerations. LBNL report # 53308, Lawrence Berkeley National Laboratory, 2003. <http://eetd.lbl.gov/ie/pdf/LBNL-53308.pdf>
- Liu, R. T. An in-situ regenerative adsorber for the control of indoor VOCs – activated carbon fibers. *Proceedings of IAQ'92*, pp. 257 – 261. ASHRAE, Atlanta, 1992.

- Lorimier, C., Subrenat, A., Le Coq L., and Le Cloirec, P. Adsorption of toluene onto activated carbon fibre cloths and felts: Application to indoor air treatment. *Environmental Technology* 2005, 26(11): 1217-1230.
- Offermann, F. J. Ventilation and Indoor Air Quality in New Homes. California Air Resources Board and California Energy Commission, PIER Energy-Related Environmental Research Program. Collaborative Report. CEC-500-2009-085, 2005.
<http://www.arb.ca.gov/research/apr/past/04-310.pdf>
- Persily, A. K. and Gorfain J. Analysis of ventilation data from the U.S. Environmental Protection Agency Building Assessment Survey and Evaluation (BASE), 2008.
<http://www.fire.nist.gov/bfrlpubs/build04/art043.html>
- Ramirez, D., Qi, S. and Rood, M.J. Equilibrium and Heat of Adsorption for Organic Vapors and Activated Carbons. *Environ. Sci. Technol.* 2005, 39, 5864-5871.
- Sheindorf, C., Rebhun M. and Sheintuch M. A Freundlich-type multicomponent isotherm. *Journal of Colloid and Interface Science* 1981, 79(1): 136-142.
- Shimer, D., Phillips, T.J. and Jenkins, P.L. Report to the California Legislature. Indoor Air Pollution in California, 2005. <http://www.arb.ca.gov/research/indoor/ab1173/rpt0705.pdf>
- Singh, K.P., Mohan, D., Tandon, G.S. and Gupta, G.S.D. Vapor-Phase Adsorption of Hexane and Benzene on Activated Carbon Fabric Cloth: Equilibria and Rate Studies. *Ind. Eng. Chem. Res.*, 2002, 41, 2480-2486.
- Subrenat, A. and Le Cloirec P. Adsorption onto activated carbon cloths and electrothermal regeneration: Its potential industrial applications. *Journal of Environmental Engineering-ASCE* 2004, 130(3): 249-257.
- Sullivan, P. D., Rood, M. J., Hay K. J. and Qi S. Adsorption and electrothermal desorption of hazardous organic vapors. *Journal of Environmental Engineering-ASCE* 2001, 127(3): 217-223.
- Yao, M., Zhang, Q., Hand, D. W., Perram D. L. and Taylor R. Investigation of the Treatability of the Primary Indoor Volatile Organic Compounds on Activated Carbon Fiber Cloths at Typical Indoor Concentrations. *Journal of the Air & Waste Management Association* 2009a, 59(7): 882-890.
- Yao, M., Zhang, Q., Hand, D. W., Perram D. L. and Taylor R. Adsorption and Regeneration on Activated Carbon Fiber Cloth for Volatile Organic Compounds at Indoor Concentration Levels. *Journal of the Air & Waste Management Association* 2009b, 59(1): 31-36.
- Yao, M., Zhang, Q., Hand, D. W., and Taylor R. Modeling of Adsorption and Regeneration of Volatile Organic Compounds on Activated Carbon Fiber Cloth. *Journal of Environmental Engineering-ASCE* 2009c, 135(12): 1371-1379.

Supporting Information

5 Energy Efficient Indoor VOC Air Cleaning with Activated Carbon Fiber (ACF) Filters

Meera A. Sidheswaran¹, Hugo Destailats^{1,2,*}, Douglas P. Sullivan¹,
Sebastian Cohn¹ and William J. Fisk¹

3. *Lawrence Berkeley National Laboratory, Indoor Environment Department*

4. *Arizona State University, School of Sustainable Engineering and the Built Environment*

5.

* *to whom correspondence should be addressed: HDestailats@lbl.gov*

Adsorption Time, (h)	Regeneration Type	Number of Cycles	Regeneration Face Velocity, m min⁻¹	Adsorption : Regeneration face velocity ratio	Regeneration Time (h)	Regeneration Temperature, °C	Special Conditions
24	Outdoor air	12	6.28	5:1	12	25	No Formaldehyde in Cycle 4 and Limonene added from Cycle 6
24	Outdoor air	5	0.31	100:1	12	25	-
24	Electrothermal	4	5.24	6:1	2	150	-
24	Electrothermal	3	0.52	60:1	2	150	-
24	Electrothermal	5	0.11	285:1	2	150	-
12	Outdoor air	5	4.2	8:1	6	25	-
12	Electrothermal	5	1.1	30:1	0.25	150	-
12	Electrothermal	5	0.52	60:1	0.25	150	RH of adsorption was > 75%, Regeneration was using dry air with RH < 3%
12	Humid air	5	6.28	5:1	6	25	RH of regeneration was > 75%

Table S-1. Experimental Conditions

		a_{ij}					K_i ($mg\ g^{-1}$)	n
j \backslash i	Benzene	1-Butanol	Toluene	o-Xylene	Undecane	Formaldehyde		
Benzene	1	1.2	0.7	1.3	1.4	0.3	7.6	0.192
1-Butanol	0.9	1	1.7	0.4	1.3	0.2	92.3	0.413
Toluene	1.8	0.61	1	0.8	0.4	0.5	123	0.721
o-Xylene	0.8	1.9	1.3	1	0.7	0.3	259	0.802
Undecane	0.7	0.81	2.4	1.6	1	0.7	454	0.814
Formaldehyde	2.9	4.7	2.4	3.2	1.8	1	1.8	0.103

Table S-2. Multi-component Freundlich Isotherm parameters for VOCs

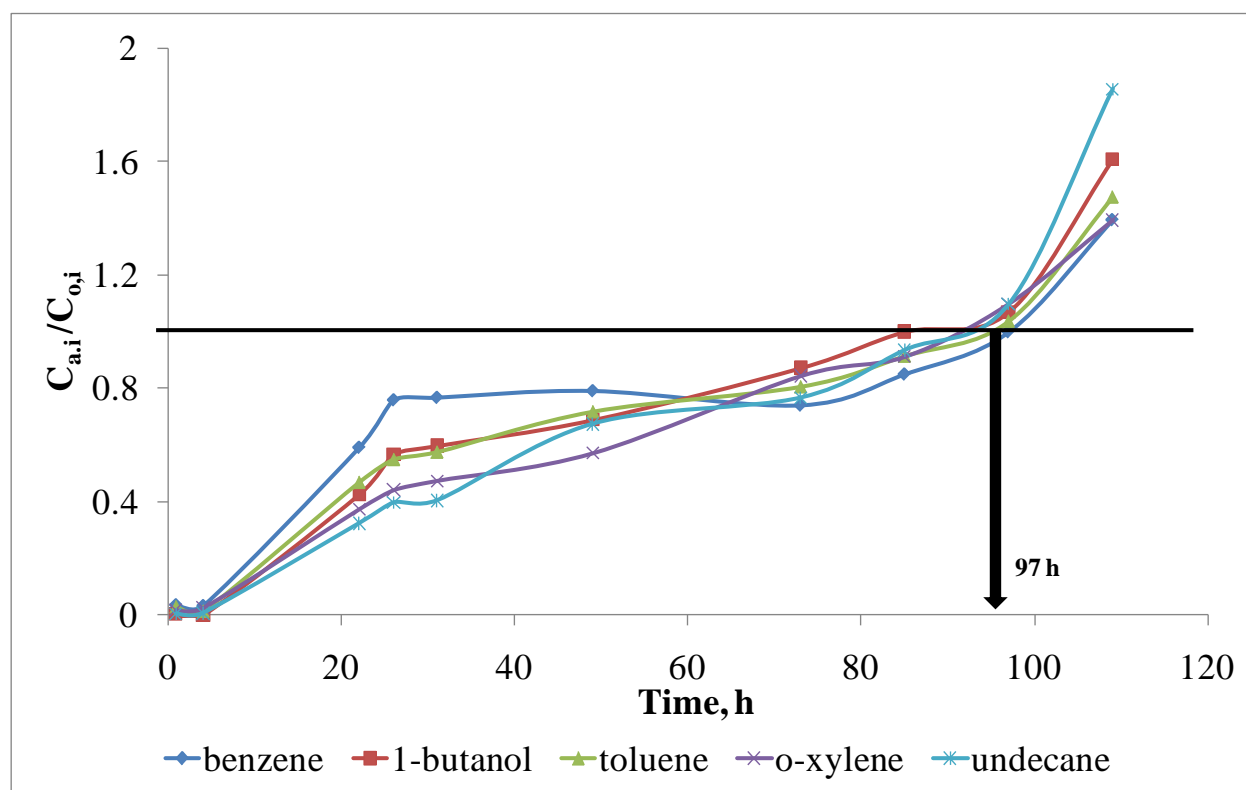

Figure S-1. Dimensionless adsorption profile for different VOCs on the surface of ACF

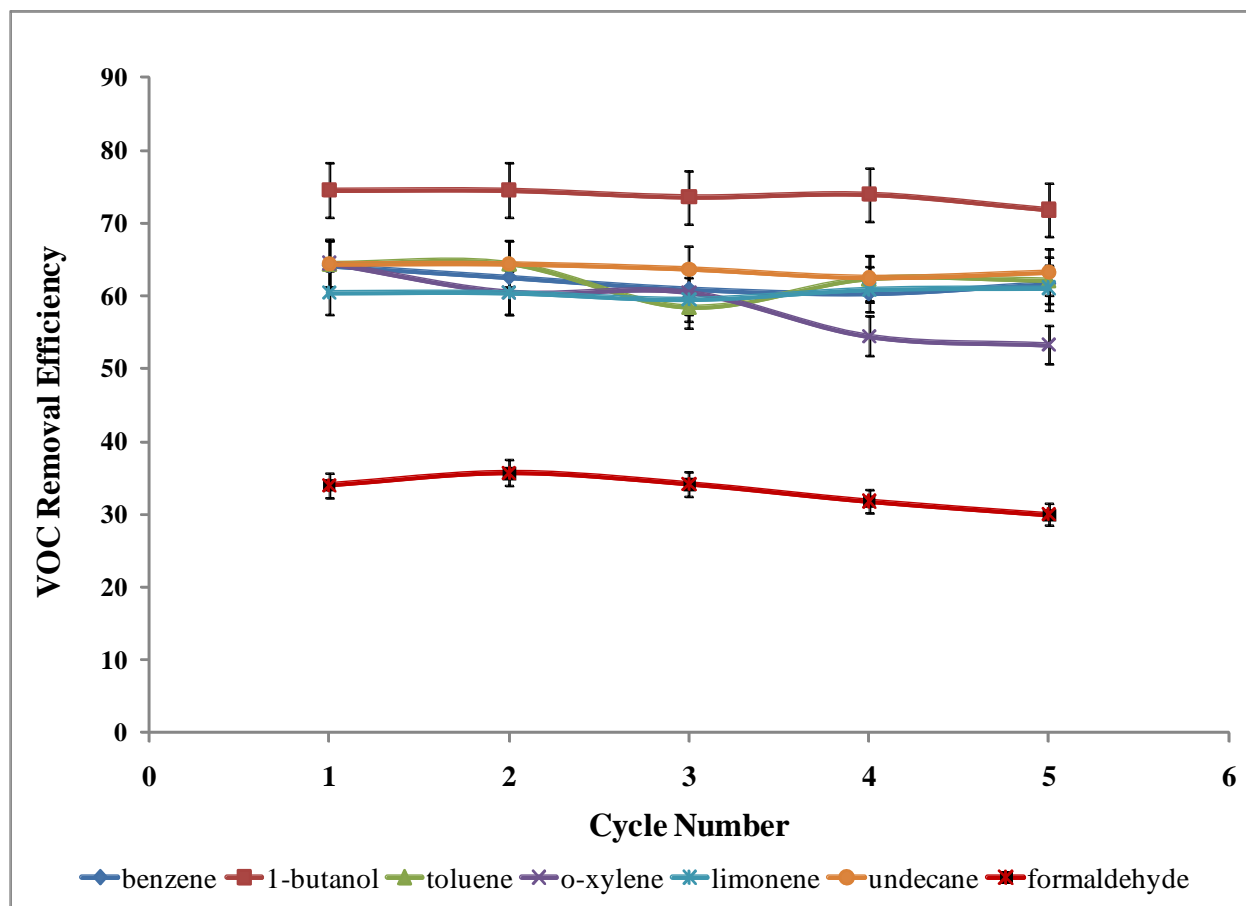

Figure S-2. VOC removal efficiency of ACF for 12 hour adsorption cycle at face velocity of 31.4 m min^{-1} with 75% RH and 15 min. regeneration period at $150 \text{ }^\circ\text{C}$ at a face velocity of 3.1 m min^{-1}

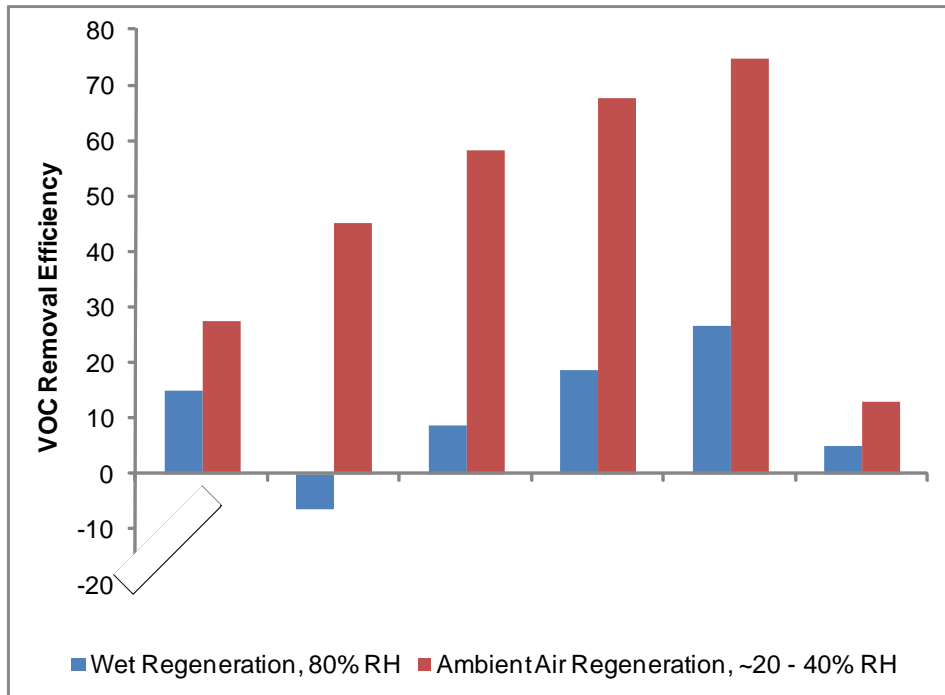
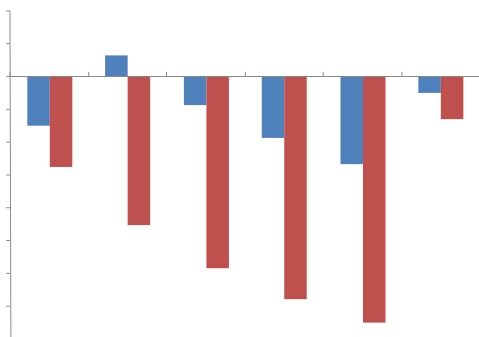

Figure S-3. VOC removal efficiency at the end of Cycle 3 for regeneration using humidified air (80% RH) and ambient conditions (20-40 % RH) for a face velocity of 6.3m min^{-1} and a 12 hour adsorption cycle.



Scenario	Case	Compounds	Removal Efficiency* (%)	N_v (h^{-1})	N_{v-ACF} (h^{-1})	S_r (ppb/h)	R_i
Low ventilation rate	1.1	Benzene	60	0.8	0.4	6.4	0.26
		1-Butanol	71				0.23
		Toluene	65				0.24
		o-Xylene	73				0.22
		Limonene	73				0.22
		Undecane	76				0.21
		Formaldehyde	24				0.56
	1.2	Benzene	46				0.33
		1-Butanol	53				0.29
		Toluene	60				0.26
		o-Xylene	56				0.28
		Limonene	54				0.29
		Undecane	54				0.29
		Formaldehyde	16				0.72
High ventilation rate	2.1	Benzene	60	1.2	0.6	6.4	0.36
		1-Butanol	71				0.31
		Toluene	65				0.33
		o-Xylene	73				0.30
		Limonene	73				0.30
		Undecane	76				0.29
		Formaldehyde	24				0.71
	2.2	Benzene	46				0.44
		1-Butanol	53				0.40
		Toluene	60				0.36
		o-Xylene	56				0.38
		Limonene	54				0.39
		Undecane	54				0.39
		Formaldehyde	16				0.88

*Determined experimentally (Case 1.1 and 2.1 heated regeneration at 150 °C at a face velocity of 1.1 m min⁻¹ for a period of 15 min, Case 1.2 and 2.2 unheated regeneration at 25 °C at a face velocity of 4.2 m min⁻¹ for a period of 6 hours. Removal efficiency averaged over 10 cycles for all of the cases after achieving steady state performance)

Table S-3. Removal efficiency and air cleaning effectiveness ratio for ACF filter fiber system with different regeneration methods.

