

# Lawrence Berkeley National Laboratory

## Lawrence Berkeley National Laboratory

### **Title**

Carbon Dioxide Fixation by Rhodospseudomonas Capsulatus

### **Permalink**

<https://escholarship.org/uc/item/26h9f9vw>

### **Authors**

Stoppani, A.O.M.

Fuller, R.C.

Calvin, M.

### **Publication Date**

1954-10-06

UCRL-2745  
Unclassified Chemistry

UNIVERSITY OF CALIFORNIA

Radiation Laboratory

Berkeley, California

Contract No. W-7405-eng-48

CARBON DIOXIDE FIXATION BY RHODOPSEUDOMONAS CAPSULATUS

A.O.M. Stoppani, R.C. Fuller and M. Calvin

Printed for the U.S. Atomic Energy Commission

CARBON DIOXIDE FIXATION BY RHODOPSEUDOMONAS CAPSULATUS\*

A. O. M. Stoppani,\*\* R. C. Fuller and M. Calvin

Radiation Laboratory and Department of Chemistry  
University of California, Berkeley, California

October 6, 1954

ABSTRACT

1. The mechanism of carbon dioxide fixation by the nonsulfur purple bacterium, Rhodopseudomonas capsulatus, has been studied. A special arrangement has been devised which allows the fixation process to take place in a closed gaseous space.
2. The average rate of fixation of  $C^{14}O_2$  in the light is about ten times the rate of fixation in the dark. In the inorganic medium hydrogen is essential for an efficient assimilation in the light, while a mixture of hydrogen and oxygen gives the highest assimilation in the dark.
3. In the light, carbon dioxide is mainly assimilated through the phosphoglyceric acid cycle, and slowly through the "malic reaction" or Krebs cycle. In the dark, the assimilation seems to take place primarily through the "malic reaction" and the Krebs cycle. A slow but significant rate of formation of PGA indicates that the "photoreduction pathway" is still func-

---

(\*) The work described in this paper was sponsored by the U. S. Atomic Energy Commission.

(\*\*) On leave from the Department of Biochemistry, School of Medicine, University of Buenos Aires, Buenos Aires, Argentina.

tioning in the dark.

4. After long enough incubation of Rhodospseudomonas capsulatus with radioactive bicarbonate, in the light or dark,  $C^{14}$  labels the intermediates of glycolysis, the Krebs cycle, and a large number of amino acids. The sugar phosphates and the amino acids are respectively the main reservoirs of the  $C^{14}$  assimilated in the light or dark.
5. Hydrogen gas provides the reducing power required for the assimilation of carbon dioxide by Rhodospseudomonas capsulatus in an inorganic medium. An additional source of energy is required which may be provided by light or oxygen. The latter source is much the poorer of the two and in the presence of light is inhibited.

CARBON DIOXIDE FIXATION BY RHODOPSEUDOMONAS CAPSULATUS\*

A. O. M. Stoppani,\*\* R. C. Fuller and M. Calvin

Radiation Laboratory and Department of Chemistry  
University of California, Berkeley, California

October 6, 1954

Rhodopseudomonas capsulatus is a nonsulfur purple bacterium (Athiorhodaceae) which photoreduces carbon dioxide with organic hydrogen donors (fatty acids, amino acids, etc.) or molecular hydrogen<sup>1-3</sup> and, on the other hand, can grow in the dark in the presence of oxygen, with the same organic substrates as source of carbon.<sup>4</sup> The fact that Rhodospirillum, another of the Athiorhodaceae, oxidizes hydrogen in the dark<sup>5</sup> makes it reasonable to assume the existence of a similar process in Rhodopseudomonas and that the energy set free in the oxidation could be made available for a further assimilation of carbon dioxide.

In plants, the main pathway for carbon assimilation is the condensation of carbon dioxide with a C<sub>5</sub> acceptor (ribulose diphosphate) with subsequent formation of phosphoglyceric acid, which is a key intermediate in the fixation process.<sup>6,7</sup> To drive these dark reactions, "reducing power" generated by the photolysis of water is required,<sup>8</sup> a reaction which presumably is the single photochemical step in photosynthesis. The extensive application of radioactive carbon (C<sup>14</sup>) has made possible the development of analyti-

---

(\*) The work described in this paper was sponsored by the U. S. Atomic Energy Commission.

(\*\*) On leave from the Department of Biochemistry, School of Medicine, University of Buenos Aires, Buenos Aires, Argentina.

cal methods sensitive enough to provide direct information on the initial steps of the CO<sub>2</sub> assimilation process.<sup>9</sup> These methods have now been used in a study of the mechanism of carbon dioxide fixation by Rhodopseudomonas capsulatus to compare the photo-autotrophic and chemo-autotrophic mechanism of carbon assimilation in purple bacteria, which heretofore was unexplored. Rhodopseudomonas capsulatus has the advantage over other species of the same group that it does not require hydrogen donors (or oxygen acceptors), which interfere with the chromatography of the fixation products.

#### MATERIALS AND METHODS

Rhodopseudomonas capsulatus\* was cultured at 30° in a medium of 0.3% yeast extract (Difco), 0.5% Na l-malate and M/30 KH<sub>2</sub>PO<sub>4</sub>, kept in completely filled one-liter glass-stoppered bottles, under 12 General Electric 40 w Lumiline tungsten lamps. The suspension of organisms was spun at 42,000 g in a Spinco refrigerated centrifuge, the sediments collected and washed once with distilled water, and the centrifugation repeated as above. The cells were finally suspended in 0.005 M KH<sub>2</sub>PO<sub>4</sub> to make a concentration of 20-70 mg/ml. The final pH of the suspension was about 6.0.

Prior to each experiment the cells were adapted for 16-18 hours to 4% CO<sub>2</sub> in hydrogen (for light fixation) or to 2% CO<sub>2</sub> and 50% hydrogen in air (for dark fixation). The difference in the CO<sub>2</sub> concentration is not considered significant for the adaptation process.

---

(\*) We are indebted to Professor Roger Stanier (Department of Bacteriology, University of California) for kindly supplying the strain used in this work.

For carbon dioxide fixation in the light, the arrangement described in Figure 1 was devised. Thirty ml cell suspension was placed in a flat flask A ("lollipop") about 40 ml volume, illuminated from both sides by 300 w lamps (D,D'). Infrared filters (C,C') were kept filled with running water to prevent any heating of the cell suspension. During the adaptation period, the gas inlet 1 was kept long enough to reach the bottom of the lollipop in order to obtain homogeneous flushing of the cell suspension. Thirty min before starting the actual experiment, the gas mixture was replaced by hydrogen to eliminate all traces of CO<sub>2</sub>. The one-liter reservoir G was filled with the proper gas mixture, through the gas inlet 2. This was controlled by draining out water through stopcock 4. Stopper 5 was then removed and the gas inlet 1 cut, to prevent its dripping into the cell suspension. After placing stopcocks 2 and 3 in the proper position, 500  $\lambda$  (0.025 mM) of radioactive NaHCO<sub>3</sub> (specific activity  $4.8 \times 10^6$  cpm/ $\mu$ mole) was added to 30 ml of cell suspension. Stopper 5 was replaced and, with stopcock 1 open, the gas stored in G was pushed through the system by allowing water to flow into the gas reservoir. The 30-ml gas compensator E was allowed to fill with the gas mixture. Stopcocks 1 and 2 were then closed, leaving the cell suspension in a closed gaseous system. The whole operation took no longer than 30 sec. Rocking of the lollipop at a rate of 150 oscillations per min was started by stirrer B in order to keep the cells from settling and to equilibrate the liquid and gaseous phases inside the lollipop. Samples of the cell suspension were collected by opening the lollipop stopcock and pushing the plunger of compensator E. When a change in the gaseous atmosphere was necessary, G was conveniently refilled. Then

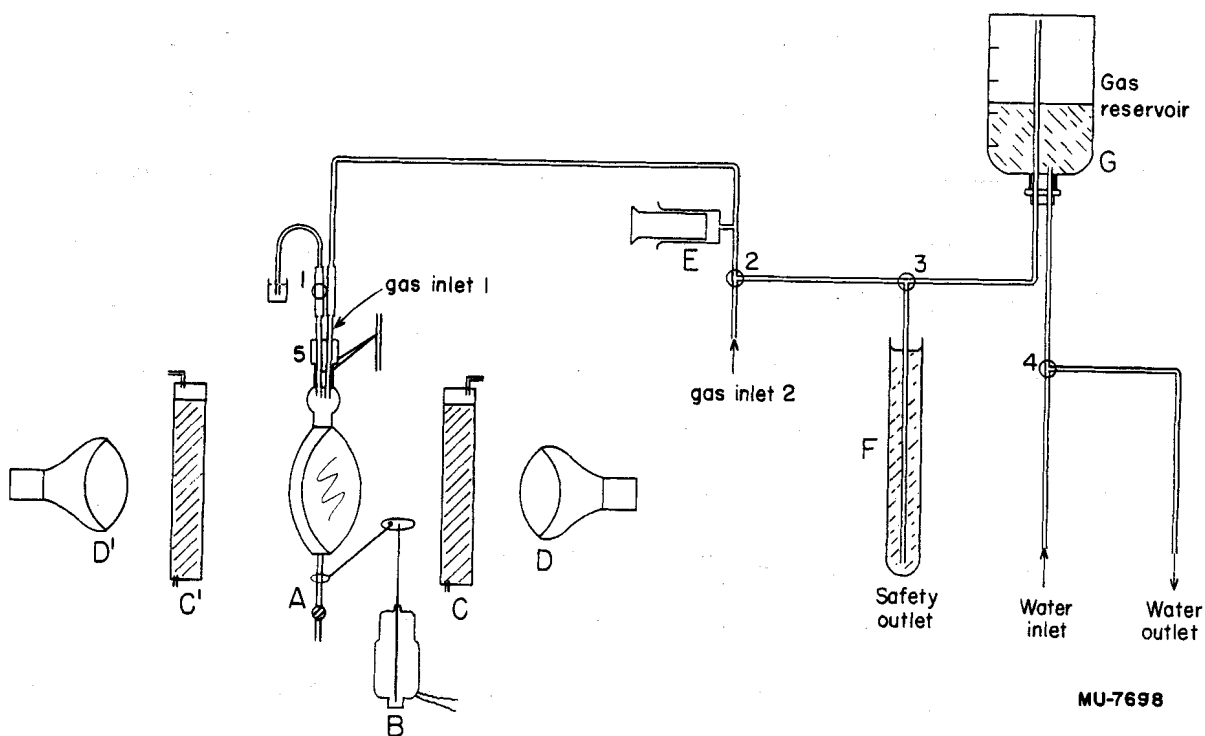

Fig. 1 Device for  $C^{14}O_2$  fixation by *Rhodospseudomonas capsulatus* in a closed space.

A, reaction cell ("lollipop"); B, stirrer; C, C', infrared filters; D, D', 300 w light sources; E, volume compensator; G, gas reservoir. For further details see text.

MU-7698

stopcock 1 was opened and 2 connected to G through 3. The whole system was flushed with the new gas mixture and the operation completed as above. For fixation of  $\text{CO}_2$  in the dark, a similar system was used but the lollipop was replaced by a 125-ml aluminum-coated separatory funnel, which was light-tight. All experiments were carried out at 22-25°C, unless otherwise stated.

The samples of the cell suspensions (1.0-2.0 ml) were dropped into and thoroughly mixed with 9.0 ml methanol. Aliquots were plated and counted with Geiger-Müller tubes of the Scott type. The methanol suspensions were spun off in the cold at 2500 rpm and aliquots from the clear supernatants were counted as well. The methanol-water-soluble extracts were distilled off in vacuum at low temperature until about 0.5 ml was left. The small amount of water-insoluble material in suspension was spun off and the clear supernatants finally evaporated for chromatography on Whatman No. 4 paper. Chromatography and radioautography were carried out as described by Benson *et al.*<sup>9</sup>

Experimental Results. - The relative proportion of the radioactive compounds after  $\text{C}^{14}\text{O}_2$  fixation has been represented by its percentage of the total radioactivity found on each chromatogram. The absolute amount could then be calculated by multiplying the percentage factor times the total activity found in the respective methanol-water-soluble extract, and will be referred to as cpm/g of cells ( $\text{cts.g}^{-1} \text{min}^{-1}$ ). Rates of fixation will be expressed as cpm incorporated by 1 g of cells per minute ( $\text{cts g}^{-1} \text{min}^{-2}$ ).

Identification of Radioactive Compounds. - The radioautographs of the chromatograms obtained after  $\text{C}^{14}\text{O}_2$  fixation by Rhodopseudomonas capsulatus

have the same pattern as those from Scenedesmus D<sub>3</sub>, which have been extensively studied in this laboratory. This gives good preliminary information in regard to the nature of the products of fixation and allows, after their elution, the further identification by rechromatography with the respective pure nonradioactive specimen. The eluates from the sugar phosphate areas were dephosphorylated with "Polidase" (Schwarz Laboratories) and the free sugars rechromatographed in the butanol-propionic acid-water system for identification.

## RESULTS

1. Rate of carbon dioxide fixation. - Rhodospseudomonas capsulatus can fix  $C^{14}O_2$  both in light and dark. In the light (with hydrogen) the rate of assimilation is almost constant for the first 30 min, and with the closed arrangement described above, rates about  $2.5 \times 10^5$  cts  $g^{-1}min^{-2}$  have been currently obtained (Figures 2 and 3). In a less elaborate setup, where the reaction cell had been opened for taking the samples, the assimilation of  $C^{14}$  was significantly less (about  $5 \times 10^4$  cts  $g^{-1}min^{-2}$ ), probably owing to dilution of the hydrogen which is essential for a high rate of assimilation. In the dark with a hydrogen-oxygen gas mixture the rate of fixation diminishes continuously through the first 30 min before reaching a near constant value. Thus, in the experiment shown in Figure 3, the fixation rate was  $2.0 \times 10^4$  cts  $g^{-1}min^{-2}$  at 1 min and  $1.5 \times 10^3$  at 60 min. Other dark fixation experiments gave similar results.
2. Factor limiting the rate of  $C^{14}O_2$  fixation. - Light and hydrogen are essential for the fast assimilation of carbon dioxide by Rhodospseudomonas capsulatus. After steady-state photofixation has been established, shutting

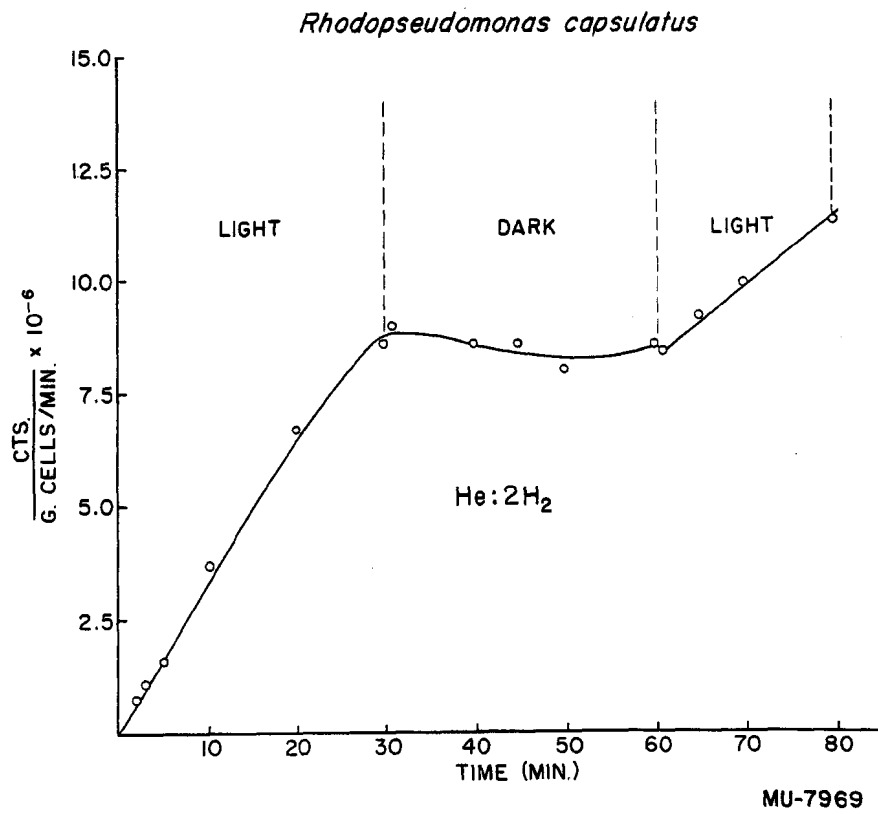

Fig. 2 Light-dark-light effect on the rate of  $C^{14}O_2$  fixation by Rhodopseudomonas capsulatus. 72 mg/ml cells. 30 ml suspension.

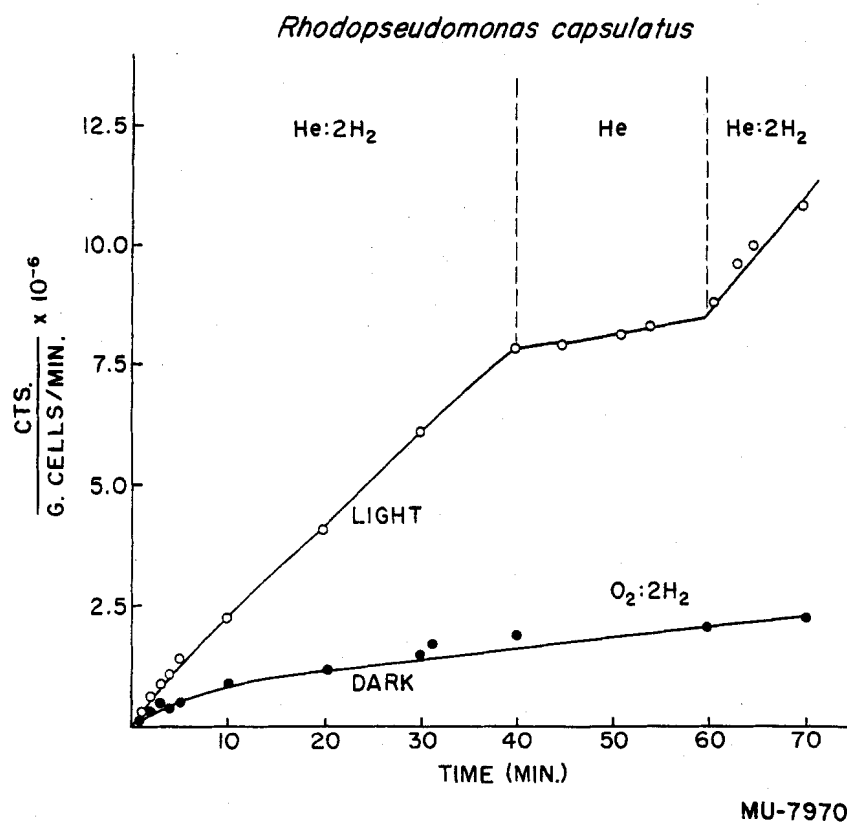

Fig. 3 Action of hydrogen on the rate of fixation of  $\text{C}^{14}\text{O}_2$  by *Rhodopseudomonas capsulatus* in the light. 57 mg/ml cells. 31 ml suspension ○ Light fixation; ● dark fixation.

off the light completely stops the assimilation process (Figure 2) and, furthermore, during the dark period the total  $C^{14}$  incorporated into the cells diminishes somewhat owing to the fermentation of sugars and proteins. In relation to this effect, it should be pointed out that French<sup>2</sup> had evidence of anaerobic endogeneous fermentation in Streptococcus varians (i.e. Rhodopseudomonas capsulatus) in the dark.

Hydrogen is also required for a high rate of fixation (Figure 3). Thus, flushing the reaction chamber with helium significantly diminishes the assimilation of  $C^{14}O_2$ . Some slow fixation still remains, but it must be pointed out that in our experimental device the hydrogen dissolved in the cell suspension cannot be removed without, at the same time, washing out the dissolved radioactive carbon dioxide. Besides, the possible formation of small amounts of hydrogen by fermentation of cellular reserve material cannot be ruled out, which, as shown by Siegel and Kamen,<sup>10</sup> takes place in other species of Rhodopseudomonas.

In the dark, with hydrogen atmosphere, a fast but short-lived fixation (about  $2.0 \times 10^4$  cts  $g^{-1} \text{min}^{-2}$ ) takes place immediately after addition of radioactive bicarbonate (Figure 4), which may be explained as the exchange of  $C^{14}O_2$  with the intracellular carbon compounds closely related to the terminal decarboxylation steps. Introduction of oxygen into the gas atmosphere immediately induces a steady rate of fixation. This shows that in the dark, carbon assimilation is bound to cell respiratory processes. In agreement with this experiment is the one shown in Figure 5, which proves that the fixation in the dark depends on the presence of hydrogen and oxygen, and, with both gases ( $2H_2:O_2$  mixture), the rate of assimilation ( $7.7 \times 10^{-3}$

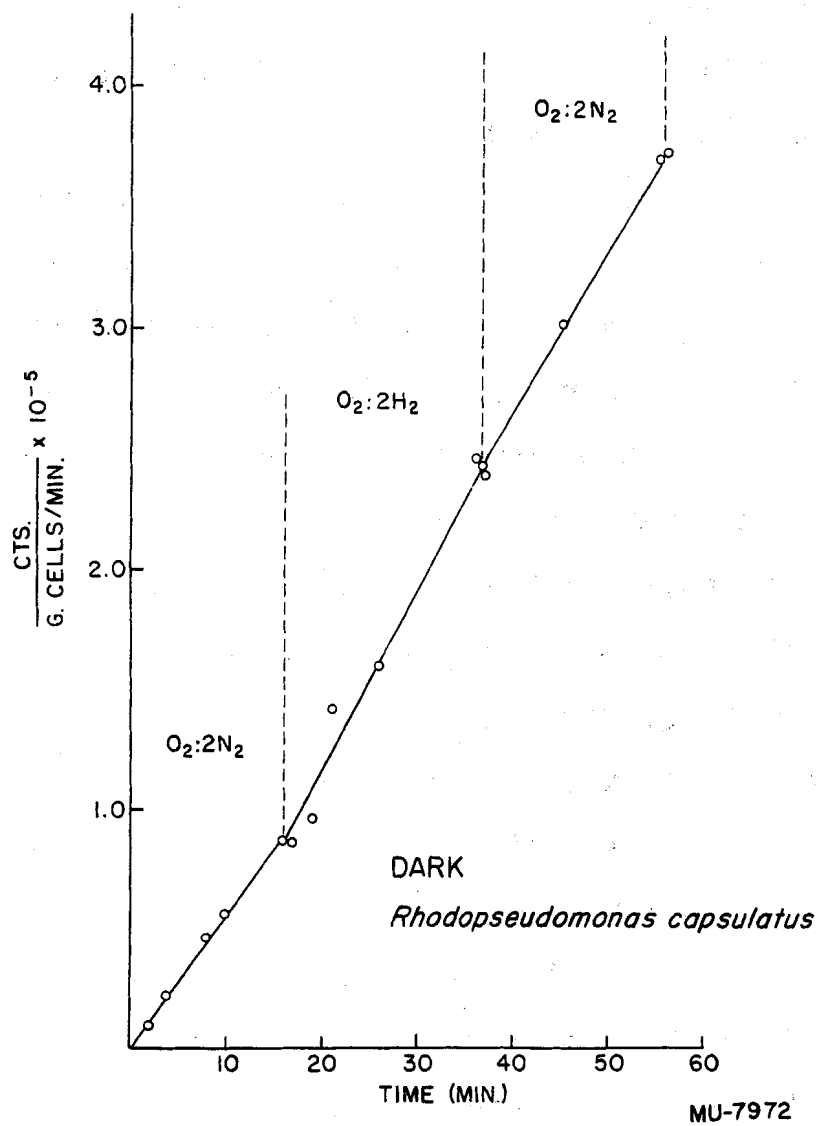

Fig. 4 Action of oxygen on the rate of fixation of  $C^{14}O_2$  by Rhodospseudomonas capsulatus in the dark. 5 mg/ml cells. 16 ml suspension.

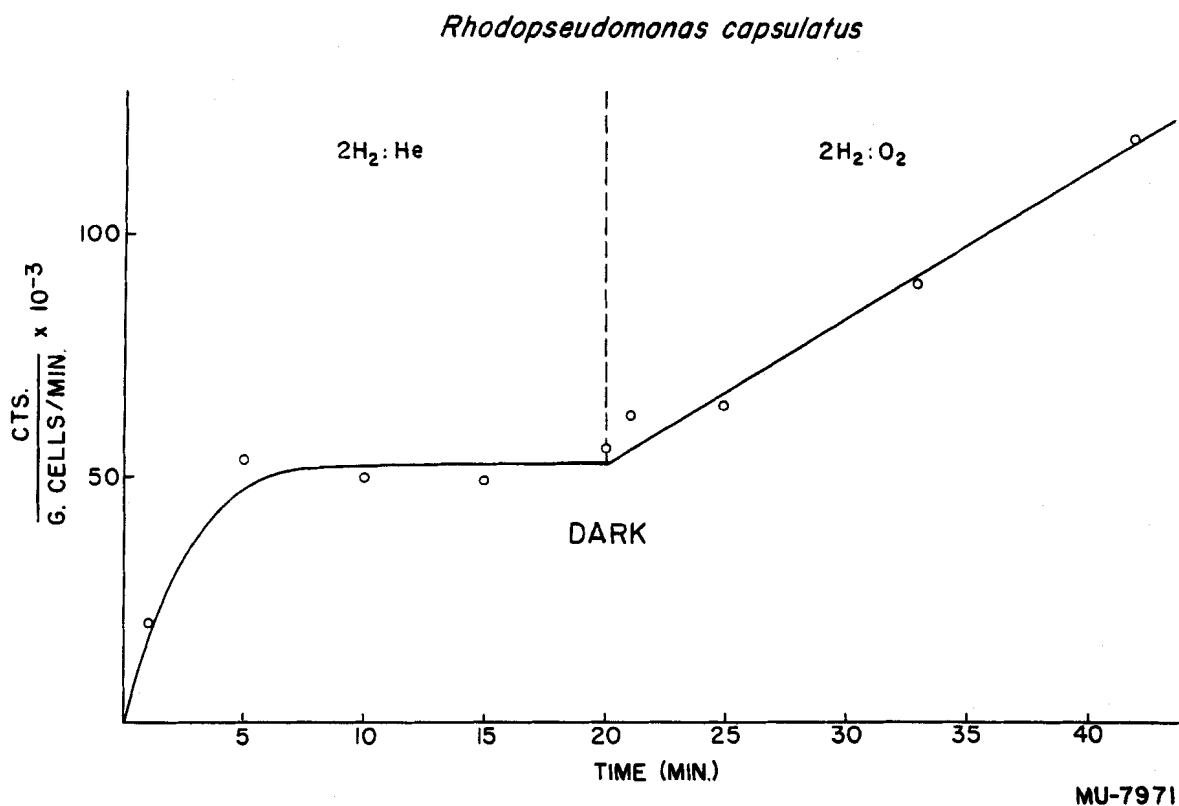

Fig. 5 Action of hydrogen on the rate of fixation of  $\text{C}^{14}\text{O}_2$  by *Rhodopseudomonas capsulatus* in the dark. 42 mg/ml cells. 32 ml suspension.

cts  $g^{-1}min^{-2}$ ) is higher than with the equivalent amount of oxygen in nitrogen ( $5.6 \times 10^3$  cts  $g^{-1}min^{-2}$ ). If the magnitude of exchange and respiratory fixation is taken into account, the chemoreductive assimilation of carbon dioxide seems to be small in relation to the assimilation by photoreduction with hydrogen. Thus in the experiment shown in Figure 5, the fixation that could be attributed to chemoreduction is about  $2.1 \times 10^3$  cts  $g^{-1}min^{-2}$ , that is, 27.3% of the total rate of fixation. Badin and Calvin<sup>11</sup> have made similar observations with Scenedesmus D<sub>3</sub> adapted to hydrogen.

3. Distribution of fixed radioactive carbon. - Rhodospseudomonas capsulatus incorporates  $C^{14}O_2$  into materials both soluble and insoluble in the methanol-water mixture. At the beginning of the fixation,  $C^{14}$  appears mainly in the low-molecular-weight methanol-water-soluble compounds (Figure 6), whereas in later steps, a large amount is incorporated into the insoluble material which may be considered formed by proteins and polysaccharides.<sup>11</sup>  $C^{14}$  fixed in the insoluble fraction amounts to from 35-60% of the total fixed. The rate of distribution change varies according to the experimental conditions. At first the incorporation in the insoluble fraction is higher in the light, but later the position is reversed and in the dark  $C^{14}$  goes into the insoluble material in a larger proportion. The initial distribution of the curves may be due to the fact that the cell proteins and polysaccharides do not incorporate  $C^{14}$  until the soluble reservoirs become saturated, which takes place much sooner in the light, and the later crossing of the curves can be attributed to the relatively smaller size of the soluble reservoirs in the dark fixation, as the  $C^{14}O_2$ -assimilating mechanisms are then far less active. If, during light fixation, the light is turned off, the  $C^{14}$  fixed

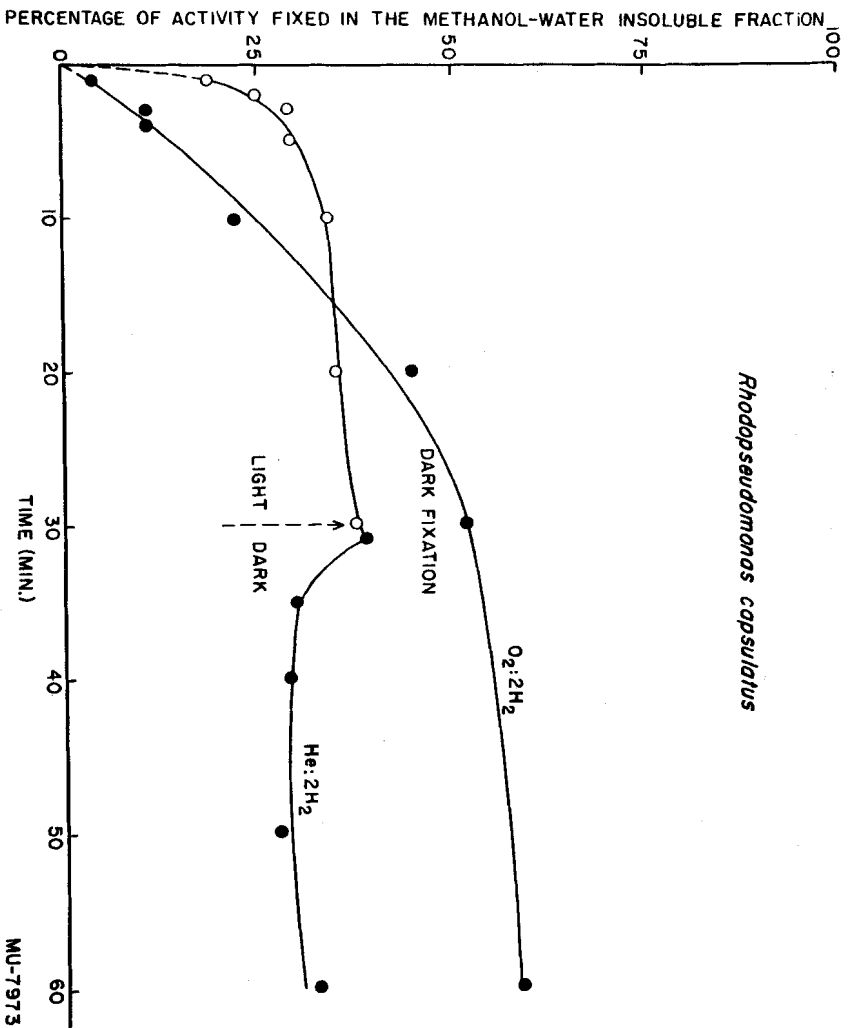

Fig. 6 Gross distribution of  $C^{14}$  after  $C^{14}O_2$  fixation by *Rhodospseudomonas capsulatus* in the light or dark. 42 mg/ml cells. 31 ml suspension. ○ Light fixation; ● dark fixation.

in the insoluble reservoir diminishes, which is a further evidence of the fermentation of proteins and polysaccharides.

In longer fixation times, either in the light or in the dark, a large number of substances are labeled by  $C^{14}$ . The main ones have been listed in Table I, which provides a qualitative comparison of the products of fixation. On account of the very different rates of incorporation of  $C^{14}$  in the light and in the dark respectively, it has not been practical to give the distribution of radioactivity after fixation of equal amounts of  $C^{14}$ . However, in both cases the fixation products are similar although the distribution of radiocarbon is quantitatively different. Thus, the main reservoirs of  $C^{14}$  in the light are the sugar phosphates, while in the dark they are the amino acids. The compounds referred to in Table I are those having enough activity to give accurate counts. There are, however, some very faint spots which in other chromatograms have been eluted and identified. Succinic and fumaric acids are additional Krebs cycle intermediates present. Among amino acids, valine, lysine, ornithine, leucine (and isoleucine), methionine, serine, aminobutyric, and proline are also labeled with  $C^{14}$ . All these amino acids appear late in the light experiments and none of them exceeds 2% of the total radioactivity fixed. In long-time experiments the amino acids as a whole represent the largest fraction of the total radioactive carbon assimilated either in light or dark.

4. Kinetics of carbon dioxide fixation. - The high rate of carbon dioxide assimilation in the light makes difficult the analysis of the initial steps of the process, as a large number of compounds become labeled even after short-time incubation with radiocarbon. In order to reduce this diffi-

Table I

Distribution of Radioactivity after  $C^{14}O_2$  Fixation by Rhodospseudomonas  
capsulatus

44.6 mg/ml cells. Light fixation: 3l ml suspension;  $2H_2:He$  atmosphere.  
Activity fixed after 2 min: total  $2.8 \times 10^6$  cts  $g^{-1}min^{-1}$ ; in methanol-  
water fraction:  $2.1 \times 10^6$  cts  $g^{-1}min^{-1}$ . Dark fixation: 4l ml cell sus-  
pension;  $2H_2:O_2$  atmosphere. Activity fixed after 10 min: total  $2.5 \times 10^5$   
cts  $g^{-1}min^{-1}$ ; in methanol-water fraction:  $1.9 \times 10^5$  cts  $g^{-1}min^{-1}$ . Temp:  $22^\circ$

Compound	Distribution of activity in methanol-water- soluble fraction (%)	
	2 min light fixation	10 min dark fixation
<u>Sugar Phosphates and Allied Compounds</u>		
Hexose mono- and diphosphates (glu- cose, fructose, ribose and ribulose)	43.2	19.6
Pentose phosphates (ribose and ri- bulose)	1.3	0.0
Phosphoglyceric acid	4.6	8.4
Phosphoenolpyruvic acid	0.7	0.8
Triose phosphate	1.9	4.0
Phosphoglycolic acid	0.6	0.0
<u>Di- and tricarboxylic Acids</u>		
Citric	0.6	2.1
$\alpha$ -Ketoglutaric	0.6	0.8
Malic	5.5	1.8
<u>Amino Acids</u>		
Glutamic	20.6	34.5
Glutamine	0.9	3.2
Aspartic	6.7	5.6
Alanine	4.5	2.3
Glycine	4.8	8.6
Threonine	0.4	2.6
Methionine sulfoxide	0.8	2.6

culty, experiments have been carried out at low temperature to slow down the bacterial metabolism and make clearer the initial steps of fixation. The results of these experiments have been quite consistent with similar observations at 22°. In the dark this is not necessary, as the rate of fixation is slow enough by itself to grant an easier analysis of the assimilating mechanism.

(a) Light fixation. - For convenience, the initial fixation reactions and the later assimilation of C<sup>14</sup> in amino acids will be dealt with separately. The relative distribution of C<sup>14</sup> in phosphoglyceric acid and sugar phosphates as an index of the role of the phosphoglyceric acid in fixation and, on the other hand, malic acid, representative of C<sup>14</sup> fixation through the Krebs cycle, is shown in Figure 7. Glutamic acid, relatively the more important of amino acids, has been included also to help represent the latter. In the first minutes of fixation the only compounds showing finite and negative initial slopes<sup>12,13</sup> in the percentage distribution plot are phosphoglyceric acid and malic acid, suggesting two at least partially independent carboxylations, with the one leading to PGA more important under these conditions. C<sup>14</sup> appears somewhat later in the sugar phosphates and glutamic acid, which increase steadily. The malic acid percentage curve shows a minimum at 10 min, and then increases again. If after 20 min fixation the light is turned off, the most significant changes are the steady increase in malic, after a sharp diminution, and the continuous decrease in the sugar phosphates (at first very fast) to reach zero value at the end of the dark period. Glutamic and phosphoglyceric acids, but for a short initial rise, keep a constant level. At the beginning of the second light

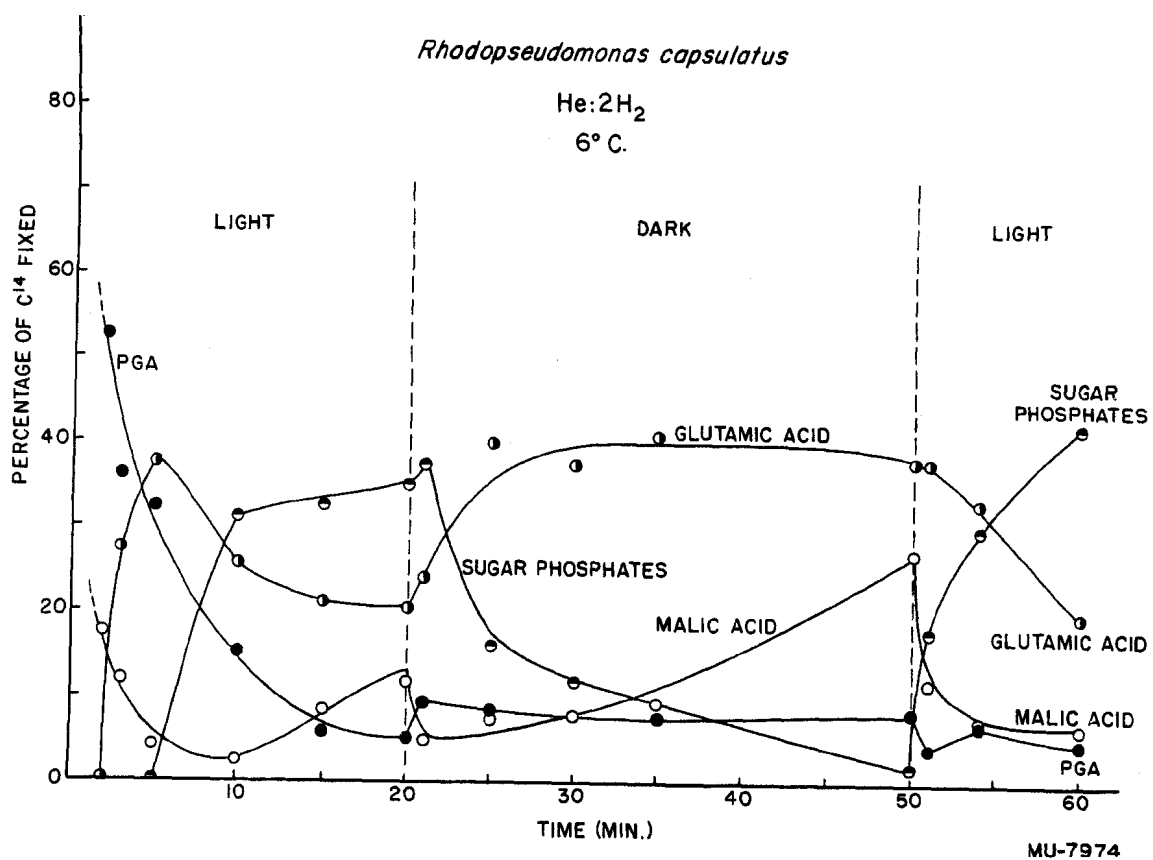

Fig. 7 Action of light-dark-light changes in the relative distribution of C<sup>14</sup> after fixation of C<sup>14</sup>O<sub>2</sub> by *Rhodospseudomonas capsulatus*. 32 mg/ml cells. 35 ml suspension. Hydrogen atmosphere. Temp: 6°.

period, the sharp increase in the absolute values (Figure 8) of phosphoglyceric and sugar phosphates as well as the transient diminution in malic are remarkable. In the percentage distribution curves there is a fast increase in the sugar phosphates and a strong diminution in malic and glutamic, while phosphoglyceric changes are far less significant.

(b) Dark fixation experiments. - These have been carried out with a  $2H_2:O_2$  mixture as the gas phase. Here, again, PGA and malic acid show finite and negative slopes in the early minutes of the percentage distribution curves (Figure 9). However, the significance of the two carboxylation processes represented in  $C^{14}$  incorporation is reversed from what it is in the light. In longer times, the malic reaches a low saturation level while the PGA is still rising at even three times the level of malic acid. Phosphoglyceric increases fast at the beginning (Figure 10) and then more slowly; the sugar phosphates appear still later. The percentage distribution of  $C^{14}$  in glutamic, after a transient initial rise, keeps constant and the total amount labeled, but for small variations, increases steadily. In other experiments of this kind, the appearance of the sugar phosphates took place even later and their relative radioactivity was also less.

(c)  $C^{14}$  distribution in amino acids. - Amino acids are a main product of carbon dioxide assimilation. Glutamic acid is one of the first labeled, and either in light (Figure 11) or dark (Figure 12) its reservoir is the largest. Glycine and alanine are labeled next, about in the same proportion in the light, whereas in the dark labeling is higher in glycine. Threonine, serine, methionine, glutamine, leucine (and isoleucine), and other amino acids appear later, but, except for threonine and glutamine, have not been

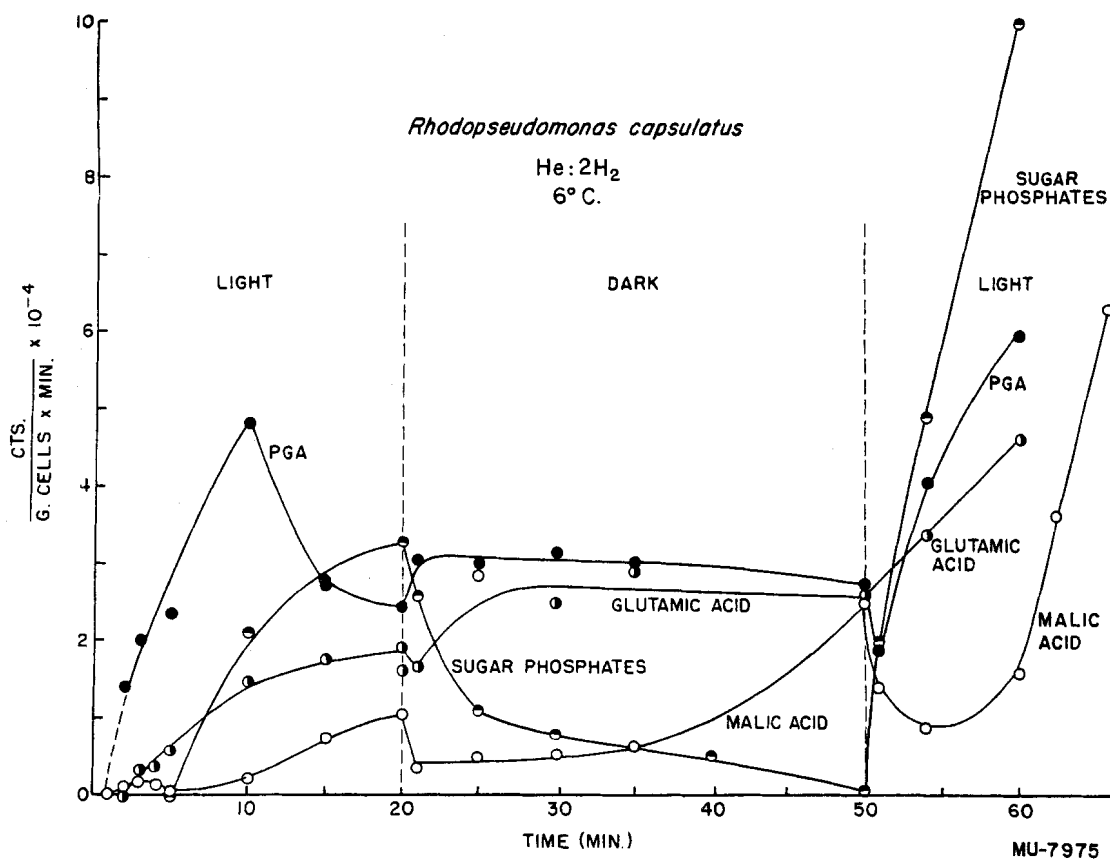

Fig. 8 Same as Figure 7. Absolute values for C<sup>14</sup> distribution.

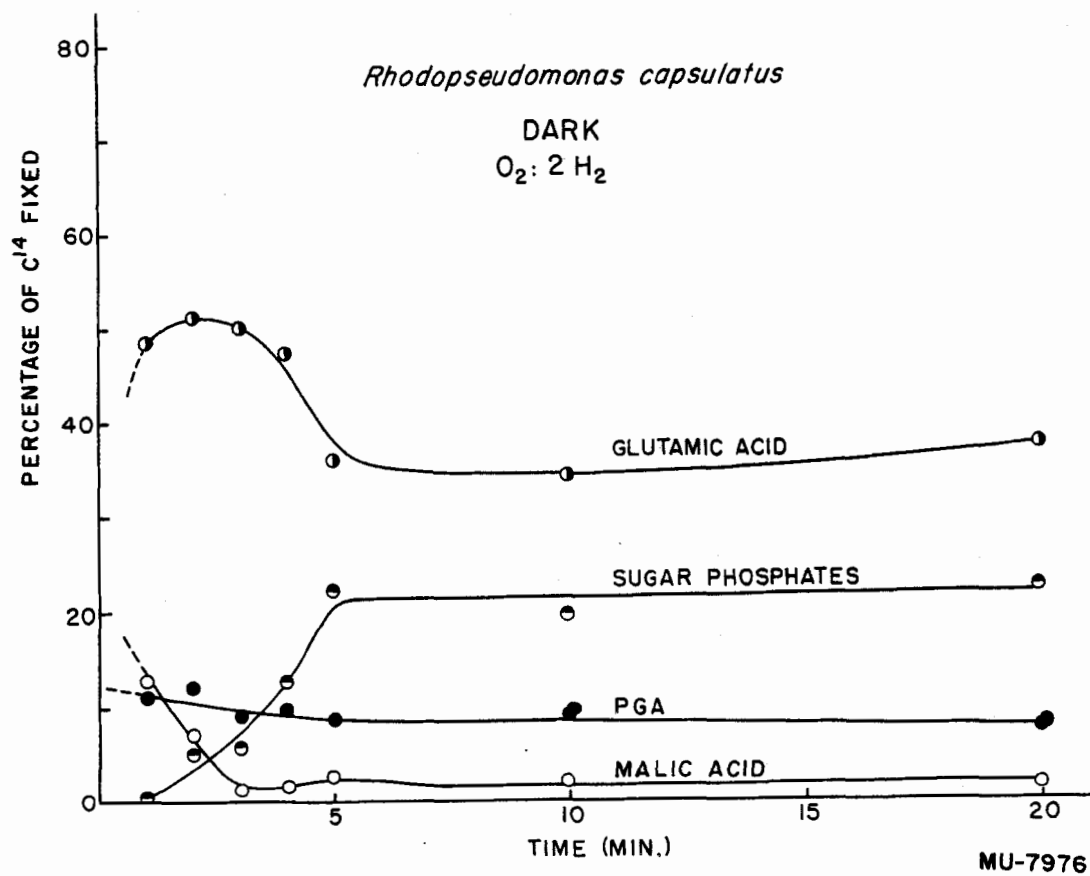

Fig. 9 Relative distribution of C<sup>14</sup> after fixation of C<sup>14</sup>O<sub>2</sub> by Rhodopseudomonas capsulatus in the dark. 44 mg/ml cells. 4l ml suspension. 2H<sub>2</sub>: O<sub>2</sub> in the gaseous space.

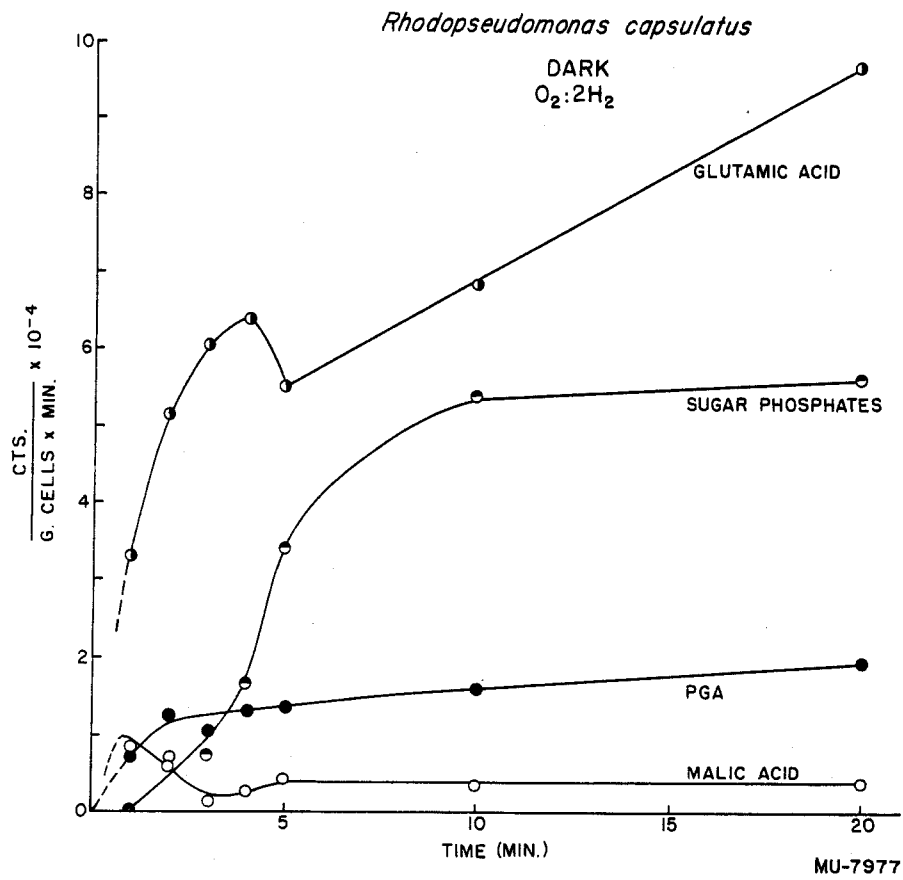

Fig. 10 Same as Figure 9. Absolute values for  $C^{14}$  distribution.

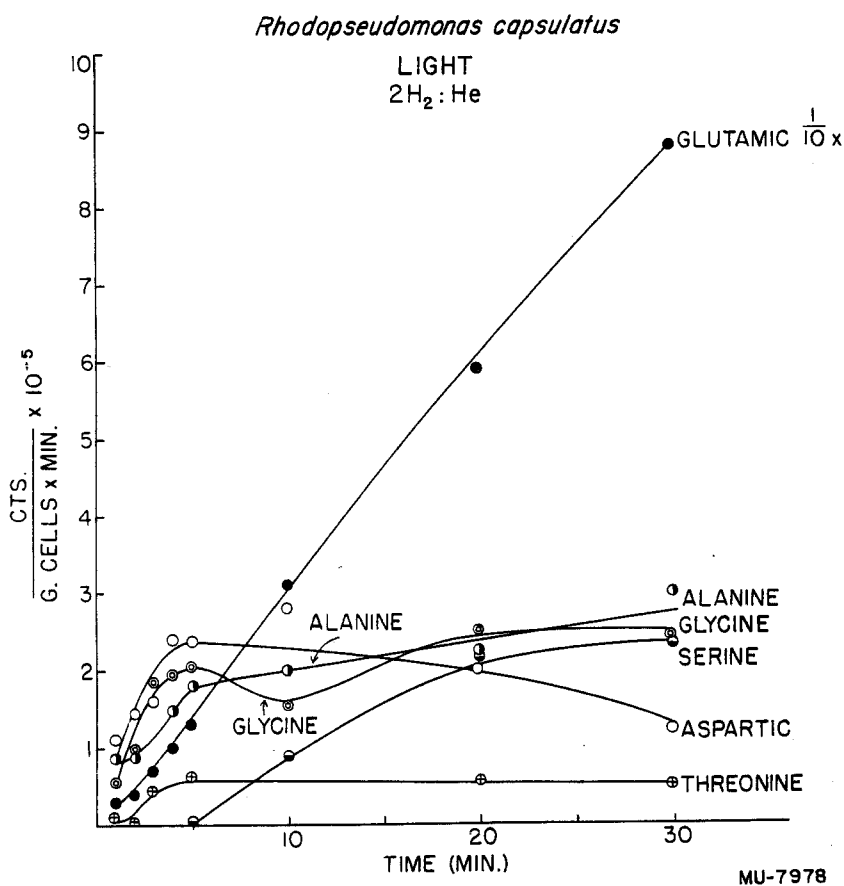

Fig. 11 C<sup>14</sup> distribution in amino acids after C<sup>14</sup>O<sub>2</sub> fixation by Rhodopseudomonas capsulatus in the light. 44 mg/ml cells. 3l ml suspension. 2H<sub>2</sub>: He in the gaseous space.

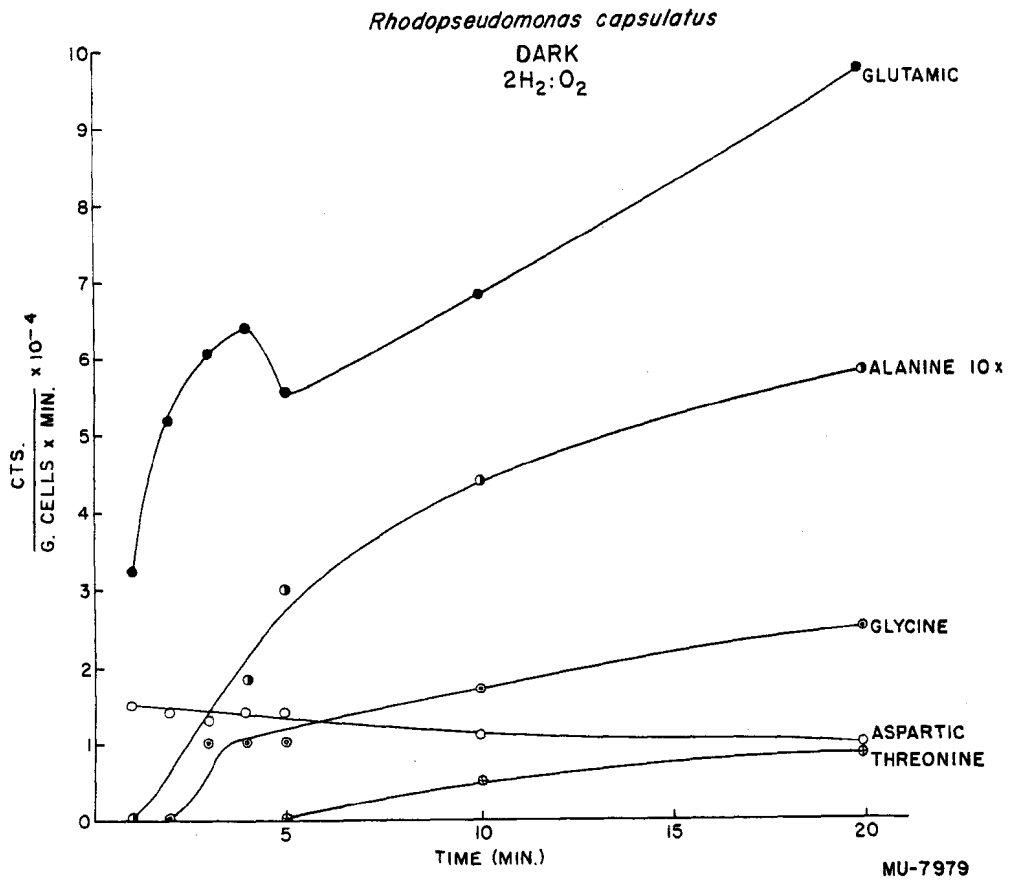

Fig. 12 C<sup>14</sup> distribution in amino acids after C<sup>14</sup>O<sub>2</sub> fixation by Rhodopseudomonas capsulatus in the dark. 44 mg/ml cells. 41 ml suspension. 2H<sub>2</sub>: O<sub>2</sub> in the gaseous space.

included in the figures. Aspartic acid may be singled out by the different pattern of its changes. In the light the total concentration increases fast at first to diminish later, while in the dark it decreases continuously all through the experiment. This resemblance to malic acid reflects the close metabolic relationship between aspartic and malic, whose behavior is compared in Figure 13. Aspartic acid appears in the chromatograms after malic acid, and, therefore, it may be assumed that malic acid may generate aspartic acid via transamination of oxalacetic acid.

#### DISCUSSION

Rhodospseudomonas capsulatus assimilates carbon dioxide in the light mainly through the photosynthetic cycle,<sup>6</sup> although some malic acid fixation takes place. The evidence lies in the fact that the percentage distribution curves show only PGA and malic acid with negative slopes, with PGA starting as by far the major component (Figure 7). Labeled malic may be formed from  $C^{14}O_2$  through two different mechanisms, namely, directly by reductive carboxylation of a  $C_3$  compound (pyruvic acid) by the malic enzyme,<sup>14,15</sup> or by fermentation, via aspartic and oxalacetic, or labeled proteins or carbohydrates formed from the labeled phosphoglyceric acid. The fermentative formation of the malic in the dark from substrates labeled in the prior light period seems to be large enough to compensate the lack of direct labeling from the photo-produced and maintained  $C_3$  pool and  $CO_2$ . This is shown by the increase in the relative and absolute amount of  $C^{14}$  in malic acid during the dark period in Figures 7 and 8, an effect which was already visible in the previous light period. Light brings about opposite effects, very likely by reducing the rate of fermentation and starting fresh photoreductive assimilation of carbon dioxide.

*Rhodopseudomonas capsulatus*

Fig. 13 Distribution of  $C^{14}$  in malic and aspartic acids after  $C^{14}O_2$  fixation by *Rhodopseudomonas capsulatus*. 36 mg/ml cells. 30 ml suspension.

Thus, in the second light period (Figures 7 and 8) the relative and absolute concentration of malic decreases for a while, as the lack of synthesis by fermentation is not yet compensated by synthesis by photoreduction of  $C^{14}O_2$ . On the other hand, phosphoglyceric acid and the sugar phosphates increase immediately, which confirms the secondary role of the "malic reaction" in carbon dioxide assimilation by Rhodopseudomonas capsulatus. In a later step, phosphoglyceric synthesis may provide enough  $C_3$  compounds to feed the reductive malic, labeling either by net formation or exchange, which would account for the sharp increase of malic at the end of the experiment. In the dark the malic acid is the major compound showing a finite and negative slope in the early minutes of the percentage distribution plot (Figure 9). The finite and negative slope of the PGA curve is not as obvious, but its presence and form indicate the functioning of the carboxylation reaction leading directly to PGA in the dark in the presence of  $H_2$  and  $O_2$ . However, it is functioning at a much slower rate than in the photoreduction.

The reducing power required for carbon dioxide assimilation in Rhodopseudomonas capsulatus seems to be generated from hydrogen activated by two main mechanisms, namely, by light (photoactivation), or during the oxidation of hydrogen by oxygen (chemoactivation). Photolysis of water, if any, must be insignificant, as shown by the almost complete arrest of fixation when hydrogen is replaced by helium. This tallies with manometric studies by French,<sup>2</sup> which show that the uptake of carbon dioxide by the bacteria in the light ceases at low hydrogen pressures. Fixation by photoreduction is by far the more important as shown by the relation between the amount of  $C^{14}$  fixed by a cell suspension in the light, under a  $2H_2:He$  gas phase ( $2 \times 10^5$  cts  $g^{-1}$

min<sup>-2</sup>) and in the dark, under 2H<sub>2</sub>:O<sub>2</sub> (2 x 10<sup>4</sup> cts g<sup>-1</sup>min<sup>-2</sup>). The difference is still larger if the figures are corrected for exchange or respiratory fixation.

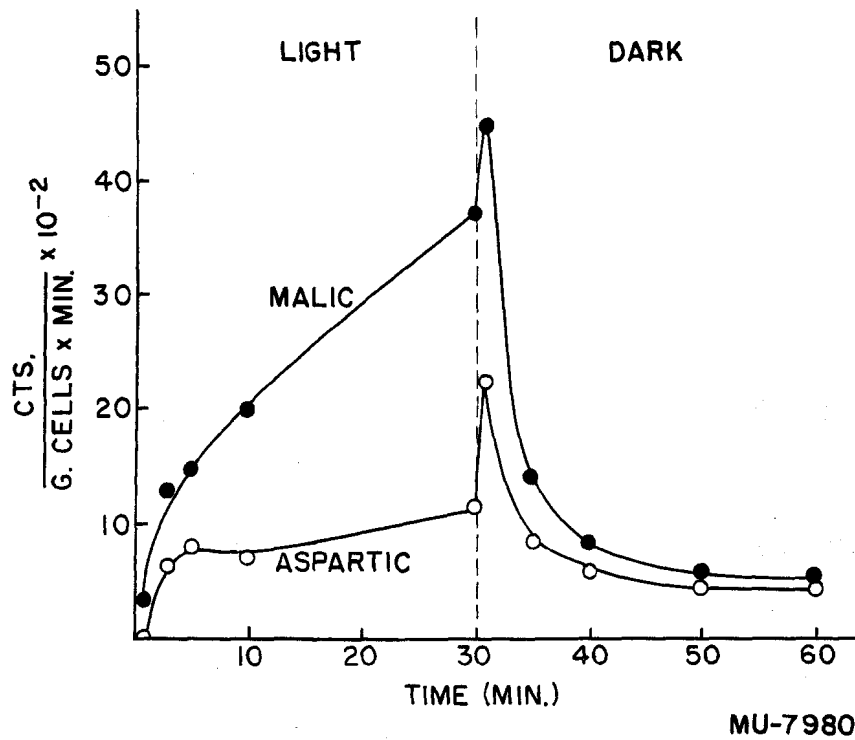
It is interesting to note that the effect of illumination of Rhodopseudomonas capsulatus in reducing the rate of flow of newly labeled three-carbon compounds (PGA) into the Krebs cycle is very similar to that reported for green algae.<sup>8</sup> It is to be expected that a relation exists between this phenomenon and the reported<sup>3</sup> and confirmed<sup>16</sup> photoinhibition of oxygen absorption by another purple bacterium, Rhodospirillum rubrum. If the two phenomena are to be encompassed by a single explanation, then the photoinhibition of O<sub>2</sub> absorption is not due solely to the photoproduction of another and better oxidizing agent which competes with O<sub>2</sub> for the activated H<sub>2</sub>. The explanation offered in the case of the green algae<sup>8</sup> is so far tenable in this case as well. If the light diminishes the amount of oxidized pyruvic acid oxidase (thioctic acid) available, it would thus constrict the flow of substrate available for the absorption of oxygen via the various oxidase systems and thus reduce the rate of oxygen absorption. It would simultaneously produce an intermediate oxidizing agent which could compete with molecular oxygen for activated reducing agents (H<sub>2</sub>- or C-H- containing fragments, depending upon the actual photosubstrate).

#### SUMMARY

1. The mechanism of carbon dioxide fixation by the nonsulfur purple bacterium, Rhodopseudomonas capsulatus, has been studied. A special arrangement has been devised which allows the fixation process to take place in a closed gaseous space.

2. The average rate of fixation of  $C^{14}O_2$  in the light is about ten times the rate of fixation in the dark. In the inorganic medium hydrogen is essential for an efficient assimilation in the light, while a mixture of hydrogen and oxygen gives the highest assimilation in the dark.
3. In the light, carbon dioxide is mainly assimilated through the phosphoglyceric acid cycle, and slowly through the "malic reaction" or Krebs cycle. In the dark, the assimilation seems to take place primarily through the "malic reaction" and the Krebs cycle. A slow but significant rate of formation of PGA indicates that the "photoreduction pathway" is still functioning in the dark.
4. After long enough incubation of Rhodospseudomonas capsulatus with radioactive bicarbonate, in light or dark,  $C^{14}$  labels the intermediates of glycolysis, the Krebs cycle and a large number of amino acids. The sugar phosphates and the amino acids are respectively the main reservoirs of the  $C^{14}$  assimilated in the light or dark.
5. Hydrogen gas provides the reducing power required for the assimilation of carbon dioxide by Rhodospseudomonas capsulatus in an inorganic medium. An additional source of energy is required which may be provided by light or oxygen. The latter source is much the poorer of the two and in the presence of light is inhibited.

REFERENCES

1. H. Gaffron, *Biochem. Z.*, 260, 1 (1933).
2. C. S. French, *J. Gen. Physiol.*, 26, 711 (1937).
3. C. B. van Niel, "Advances in Enzymology," Vol. 1, 263 (1941).
4. C. B. van Niel, *Bact. Rev.*, 8, 1 (1944).
5. H. Gaffron, *Biochem. Z.*, 275, 301 (1935).
6. J. A. Bassha, A. A. Benson, L. D. Kay, A. Z. Harris, A. T. Wilson and M. Calvin, *J. Am. Chem. Soc.*, 76, 1760 (1954).
7. J. R. Quayle, R. C. Fuller, A. A. Benson and M. Calvin, *J. Am. Chem. Soc.*, 76, 3610 (1954).
8. M. Calvin and P. Massini, *Experientia*, 8, 445 (1952).
9. A. A. Benson, J. A. Bassham, M. Calvin, T. C. Goodale, V. A. Haas and W. Stepka, *J. Am. Chem. Soc.*, 72, 1710 (1950).
10. J. M. Siegel and M. D. Kamen, *J. Bact.*, 61, 215 (1951).
11. E. J. Badin and M. Calvin, *J. Am. Chem. Soc.*, 72, 5266 (1950).
12. M. Calvin, J. A. Bassham, A. A. Benson, V. H. Lynch, C. Ouellet, L. Schou, W. Stepka and N. E. Tolbert, *Symp. Soc. Exptl. Biol.* (Great Britain), No. V (1951).
13. A. A. Benson, S. Kawaguchi, P. M. Hayes and M. Calvin, *J. Am. Chem. Soc.*, 74, 4477 (1952).
14. W. Vishniac and S. Ochoa, *J. Biol. Chem.*, 195, 75 (1952).
15. L. J. Tolmach, *Arch Biochem. Biophys.*, 33, 120 (1951).
16. J. A. Johnston and H. A. Brown, *Plant Physiol.*, 29, 177 (1954).