

Lawrence Berkeley National Laboratory

LBL Publications

Title

Summary of the FESAC Transformative Enabling Capabilities Panel Report

Permalink

<https://escholarship.org/uc/item/2b3713jv>

Journal

Fusion Science & Technology, 75(3)

ISSN

0748-1896

Authors

Maingi, R
Lumsdaine, A
Allain, JP
[et al.](#)

Publication Date

2019-04-03

DOI

10.1080/15361055.2019.1565912

Peer reviewed

Summary of the FESAC Transformative Enabling Capabilities panel report

R. Maingi¹, A. Lumsdaine², J.P. Allain³, L. Chacon⁴, S.A. Gourlay⁵, C.M. Greenfield⁶, J.W. Hughes⁷, D. Humphreys⁶, V. Izzo⁸, H. McLean⁹, J.E. Menard¹, B. Merrill¹⁰, J. Rapp², O. Schmitz¹¹, C. Spadaccini⁹, Z. Wang⁴, A.E. White⁷, B.D. Wirth¹²

¹ Princeton Plasma Physics Laboratory

² Oak Ridge National Laboratory

³ University of Illinois, Urbana-Champaign

⁴ Los Alamos National Laboratory

⁵ Lawrence Berkeley National Laboratory, *retired*

⁶ General Atomics

⁷ Massachusetts Institutes of Technology

⁸ *formerly of* University of California, San Diego

⁹ Lawrence Livermore National Laboratory

¹⁰ Idaho National Laboratory

¹¹ University of Wisconsin, Madison

¹² University of Tennessee, Knoxville

Abstract

The US Fusion Energy Sciences Advisory Committee (FESAC) was charged ‘to identify the most promising transformative enabling capabilities (TEC) for the U.S. to pursue that could promote efficient advance toward fusion energy, building on burning plasma science and technology.’ A subcommittee of U.S. technical experts was formed, and received community input in the form of white papers and presentations on the charge questions. The subcommittee identified four ‘most promising transformative enabling capabilities’:

- Advanced algorithms
- High critical temperature superconductors
- Advanced materials and manufacturing
- Novel technologies for tritium fuel cycle control

In addition, one second tier TEC, defined as a ‘promising transformative enabling capability’ was identified: fast flowing liquid metal plasma facing components. Each of these TECs presents a tremendous opportunity to accelerate fusion science and technology toward power production. Dedicated investment in these TECs for fusion systems is

needed to capitalize on the rapid advances being made for a variety of non-fusion applications, to fully realize their transformative potential for fusion energy.

Introduction

Fusion reactions are the primary source of energy in the known universe, powering the stars and our sun. Because the source of fusion fuel on earth is virtually unlimited, consisting of deuterium from water and lithium from rocks and is used to generate tritium, the realization of commercially viable fusion power would solve the problem of securing a clean, global energy supply. However, controlled fusion energy on earth is a science and technology grand challenge, and challenges remain to develop and deploy fusion power stations.

In 2017, the Fusion Energy Sciences Advisory Committee (FESAC) was charged “to identify the most promising transformative enabling capabilities (TEC) for the U.S. to pursue that could promote efficient advance toward fusion energy, building on burning plasma science and technology.” This study sought to identify technologies or capabilities that could shorten fusion energy development time, and bring an affordable fusion power station to market more quickly. The FESAC formed a subcommittee of U.S. technical experts that received community input via white papers and presentations on the charge questions. The subcommittee also leveraged previous community reports to identify gaps and research needs, and to shape pathways for the future of fusion energy research.

Within the subcommittee's deliberations, the following working definition was adopted:

A TEC is a *revolutionary* idea, that is beyond *evolutionary*; it is a "*game-changer*." A TEC would dramatically increase the rate of progress towards a fusion power plant. Examples of payoffs include a substantial increase in fusion performance, enabling device simplification, reduction in fusion system cost or time to delivery, or improvement in reliability and/or safety.

Two tiers of TECs were identified:

- In the first group, the capability is advancing rapidly as driven by other fields, and/or the reward/risk ratio is clearly favorable; these are highlighted as very promising TECs.
- In the second group, the transformative potential is clear, but risks are more substantial, and/or the rewards are more difficult to quantify; these are highlighted as promising TECs.
- Some TECs would benefit from innovations in other TECs to fulfill their promise.

In addition to these TECs, a number of activities were identified as foundational, but not qualifying as "transformative", on the path toward a fusion reactor. These capabilities are nonetheless necessary and the development of a fusion power plant probably cannot happen without them. These necessary elements are largely part of the existing fusion

science R&D program, and are examined in the full FESAC TEC report, including a discussion of necessary testing facilities.

First Tier Transformative Enabling Capabilities

The four top tier TECs identified by the panel are: advanced algorithms, high critical temperature superconductors, advanced materials, and novel technologies for tritium fuel cycle control. No prioritization amongst these four sets of capabilities was attempted.

Advanced Algorithms

Summary. Advanced algorithms will transform our vision of feedback control for a power-producing fusion reactor. The vision will change from one of basic feasibility to the creation of intelligent systems, and perhaps enabling operation at optimized operating points whose achievement and sustainment are impossible without high-performance feedback control. In the same way that control advances were the key to enabling heavier-than-air flight, advances in algorithmic control solutions will accelerate research toward a viable steady state, disruption-free fusion reactor, as well as understanding of basic physics issues.

The area of advanced algorithms includes the related fields of mathematical control, machine learning, artificial intelligence, integrated data analysis, and other algorithm-based research and development. The fields that make up this TEC area are related through their use of

sophisticated algorithms, often only made possible by high-performance computing technologies. These algorithms enable, enhance, and accelerate: scientific discovery through efficient data analysis, knowledge extraction from large and complex data sets, and real-time control solutions. The algorithms could be applied to aid in understanding many aspects of fusion science, e.g. confinement, turbulence, and transport. Given the pace of advances, control solutions that establish fusion reactor operation will become within reach, as will the discovery and refinement of physics principles embedded within the data from present experiments. This TEC offers tools and methods to support and accelerate the pace of physics understanding, leveraging both experimental and theoretical efforts. These tools are synergistic with advances in exascale and other high-performance computing capabilities that will enable improved physics understanding. Machine learning and mathematical control can also help to bridge gaps in knowledge when these exist, for example to enable effective control of fusion plasmas with imperfect understanding of the plasma state.

Mathematical control is the field of mathematics that makes use of sufficiently accurate models of physical phenomena and provides theorems and methods for designing control algorithms to satisfy operational requirements¹⁻⁶. This discipline enables design of effective control, often with imperfect models, and provides methods for quantifying risk and performance under many conditions. An example of

a state-of-the-art mathematical control diagram for tokamak operation free of unmitigated disruptions is shown in [Figure 1](#).

Machine learning (ML) derives methods for identifying predictive mappings from known inputs to known outputs in a poorly characterized system^{3, 5, 7, 8}. It enables identification of patterns and fundamental knowledge from large sets of experimental data, potentially beyond that identifiable by traditional analysis. ML tools can enhance researcher effectiveness in analyzing data, and enable design of control algorithms based on dynamics inherent in large datasets without explicit model definition. The closely related fields of artificial intelligence (AI) and expert systems enable construction of systems that embody a domain of knowledge and can make complex judgments in that domain, either to support or replace human action⁹⁻¹². In the same way that ML is transforming autonomous control^{13, 14} and revolutionizing the way pharmaceutical science is done¹⁵, this field could dramatically accelerate fusion science and energy by assisting and enhancing the discovery science process, and producing control solutions that are presently inaccessible.

Integrated data analysis (IDA) is a novel analysis methodology that embodies a probabilistically-underpinned systematic approach to mixed data analysis¹⁶. It provides a powerful framework for systematically managing limitations and uncertainties in measurements, combining all

relevant information so as to reveal all of the knowledge available from a set of related measurements. While extracting maximum understanding from experiments, this methodology simultaneously quantifies the uncertainties and probabilities implied by the integration of all data available. Related approaches include frameworks for integrating raw and interpreted data with computational analysis that provides either synthetic diagnostic information or projected physics information^{16, 17}.

Other algorithmic science and technology research encompassed by this TEC area include real-time analysis of complex plasma conditions such as the plasma state and MHD stability. Faster-than-Real-Time simulation of the plasma state, coupled with real-time analysis capabilities, is one example identified as a requirement for ITER operation^{3, 18, 19}.

The closely related fields in this TEC can play important roles in solving large challenges in fusion energy development. For example, each of these fields includes powerful approaches to dealing with limitations in knowledge of underlying system dynamics and principles. Control mathematics offers systematic ways to achieve desired performance in a reactor even with gaps in the understanding of the underlying physics, provided the actuators are sufficient to access the performance, and sensors are sufficient to measure relevant parameters. Control also offers the solutions to providing robust, sustained operation of a reactor in true long-term, disruption-free steady state. Machine learning offers

methods for generating useful models, even when the underlying physics is not fully understood. Expert systems enable capture, identification, and application of knowledge in particular domains even when no single person possesses such a collection. Integrated data analysis can extract maximum information from an increasingly complex combined data environment (including results of computational analysis), and produce probabilistically qualified data to characterize the uncertainty and confidence level of both experimental and theoretical conclusions. Taken together, the elements of this TEC area hold significant promise for accelerating progress of fusion research toward the realization of an attractive, practical power reactor.

High Critical Temperature Superconductors

Summary. Advances in higher temperature and/or higher field superconductors (HTS) present a game-changing opportunity to enhance the performance and feasibility of fusion reactor designs. Superconducting magnet systems are the essential enabling technology for magnetic confinement fusion devices, and fusion reactors designed with high magnetic fields have practical advantages. The transformative aspect of high-temperature superconductors comes from their ability to produce magnetic fields well beyond currently available technology, and to potentially reduce the time and cost of fusion science research for power generation. Achievement of higher magnetic fields would result in more compact burning plasma experiments, with high-energy gain and

high power density that would be more economically attractive for commercialization. We note that although a compact reactor also has limitations due to complex coupled and interacting constraints, future technology advances (such as the materials, manufacturing, and liquid plasma-facing surfaces addressed in next TEC element) may relax these constraints in unforeseen ways.

Continued R&D following the discovery of high-temperature superconductivity in the late 1980's has resulted in superconductors that can now be considered for high field magnetic fusion applications. The high field and temperature properties of HTS allow the possibility of eliminating cryogen²⁰ and enabling the use of demountable resistive joints²¹. In addition, the high critical temperature could also allow operating in a nuclear heating environment significantly higher than allowed in low-temperature superconductor (LTS) magnets.

There are two primary HTS materials that are sufficiently mature for the next step of magnet development: rare-earth barium copper oxide (REBCO) tapes ([Figure 2](#)) and Bi-2212 round strands. Iron-based superconductors²² are on the horizon, and with a breakthrough could be a candidate within the next decade or so. REBCO superconductors carry sufficient current density for magnet applications at fields up to 100 T²³,²⁴. REBCO has been successfully used to reach fields over 40 T in solenoids²⁵ and has achieved²⁶ engineering current densities exceeding

1000 A/mm². This is an order-of-magnitude higher current density compared to LTS equivalent fusion magnets. This capability leads to smaller magnets for the same magnetic field. For example REBCO nuclear magnetic resonance magnets at fields over 35T are now under construction²⁷. This exceeds the requirement of ~20T as embodied in compact high-field tokamak designs. REBCO can operate at over 90K but performs much better at lower temperatures and thus high-field fusion and accelerator magnets often target 20-30K. The significance of the high-temperature operation goes well beyond the thermodynamic advantages in the cryogenic system. Operation at temperatures significantly above those limited by liquid helium, and the relative insensitivity of the critical current to temperature, results in magnets with much higher operating stability — a critical consideration for the long-life operation required in a dynamic fusion environment. Further, these properties have enabled some REBCO magnets to forgo incorporating electrical insulation. REBCO's primary constituent material (~50-90% by volume) is high-strength nickel alloys or steels. REBCO has been shown to remain superconducting at stresses over 600 MPa and strains up to 0.45%²⁸, a factor of 2 - 3 improvement over LTS. Several studies have verified that REBCO has similar resistance to neutron damage as Nb-Ti and Nb₃Sn^{29, 30}. REBCO does not require any subsequent heat treatment, resulting in simpler coil fabrication relative to materials that require heat treatment subsequent to winding.

Bi-2212 is another possible candidate with the advantage of being available as a round strand and the electrical and magnetic properties compare well with REBCO. However, Bi-2212 requires a rather complex, high-pressure heat treatment and has poor mechanical properties. While the high silver content (~75%) also makes it less attractive for fusion applications, further cable development could make Bi-2212 useful in pulsed magnet systems.

Advanced Materials and Manufacturing

Summary. New material designs and advanced fabrication will enable the realization of resilient components that are essential to survive the harsh fusion environment and to optimize the reactor's performance. The novel features enabled by advanced manufacturing and additive manufacturing include complex geometries and transitional structures, often with materials or constituents including hard-to-machine refractory metals; the potential for local control of material microstructure; rapid design-build-test iteration cycles; and exploration of materials and structures for containing and delivering slow-flow liquid metals. With these emerging techniques, resilient materials and components for a fusion reactor can be realized. Moreover these innovative materials should enable the realization of compact cost-effective fusion device designs that, as a by-product, tend to concentrate plasma bombardment into small deposition areas.

Plasma facing components, actuators, blankets, and structural materials for magnetic thermonuclear fusion must survive and safely perform their intended functions in an extremely hostile environment that includes high heat flux, plasma particle flux, and volumetric damage associated with a flux of high-energy neutrons. The plasma strongly perturbs material surfaces through erosion, redeposition, and implantation of hydrogen and helium particles. The eroded material redeposits continually as complex-bonded thin-films whose properties can change over time, given their evolving surface morphology and composition. This evolving plasma-facing interface can have significant ramifications for fuel recycling, impurity emission and overall machine operation. Interaction of fusion neutrons with structural materials produces residual point defect clusters and both solid and gaseous transmutation products in the bulk that can have significant effects on thermo-mechanical properties. Intense heat loads lead to high material operating temperatures and significant thermal gradients that effectively couple bulk damage evolution with the physical processes governing near-surface material evolution. Additional fusion materials challenges include: corrosion and fatigue damage caused by neutron loading and mechanical loading on structural and blanket materials, as well as on actuators operating in similar extremes. Similarly, high-field strength magnets must survive neutron degradation and require advancements in the strength and ductility of the magnet structural support components. Current conventional materials cannot meet the stringent

requirements expected under reactor-relevant conditions of radiation, temperature, stress and pressure. New material design and processes are critical to enable design of materials capable of sustaining the above-mentioned conditions. Advances in novel synthesis, manufacturing and materials design are providing for some of the most promising transformation enabling technologies in PMI and nuclear fusion materials to enable fusion energy for the future.

Advanced Manufacturing refers to multiple technologies that are emerging and rapidly evolving as the industrial manufacturing route of choice for fabricating components with features not readily achievable by conventional processing technologies. The novel features enabled by advanced manufacturing include complex geometries and transitional structures, often with materials or constituents that are refractory and/or hard to machine¹, the potential for local control of microstructure², and rapid design-build-test iteration.

Additive manufacturing (AM), or 3D printing, methods have become the most popular and versatile of these emerging manufacturing techniques. At its core, these methods revolve around the ability to place material and structure where desired in a bottom up, layer-by-layer fashion, as opposed to material removal methods such as machining and etching. There already exists a large suite of commercially available additive manufacturing tools capable of fabricating materials ranging from

polymers to metals and even ceramics in some limited cases, and with feature sizes ranging from 200 nanometers up to tens of centimeters. Additionally, research groups and start-up companies around the world are rapidly advancing the technologies to have capabilities such as mixed material printing, multi-scale features, and overall part sizes in the many-meter range. To date, AM is seeing multibillion-dollar investments in the commercial sector as evidenced by General Electric's recent acquisitions of Concept Laser and Arcam³, two of the world's preeminent metal AM machine providers.

Additive manufacturing tools represent a new, rapidly evolving, and powerful paradigm for component and material production. Because AM tools require little setup time and minimal fixturing, they make possible the production of any quantity at the same cost per unit, and also allow easy, rapid switching between designs and, in some cases, materials. As a result, AM is often said to be enabling "mass customization" as opposed to mass production. Additionally, a 3D additive printer can fabricate in a single piece an object that would otherwise have to be manufactured in several parts and then assembled. Because it composes objects layer-by-layer, instead of carving them from larger blocks, AM could considerably reduce waste generation associated with standard production methods.

Although in many industrial sectors, companies are pushing for AM to challenge more conventional mass production methods (e.g. GE Aviation), it is generally accepted that current printing machines are most suited to low volume, high value, high complexity, bespoke components. This is ideal for the foreseen needs of the first fusion reactors. Consequently, this discussion focuses on specific advantages for fusion energy, primarily via metal AM. We note the substantial commercial efforts for just-in-time manufacturing to ensure products that are predictably within tolerance, using inverse solutions, uncertainty quantification, and dynamic process control. Capitalizing on these commercial trends will become timely when fusion moves toward high-volume products.

Metal additive manufacturing can be done via many methods, although the most popular involve powder bed methods. The two most common examples of this are selective laser melting (SLM) and electron beam melting (EBM). In both cases, a thin layer of metal powder is first spread over a substrate and is then locally (point by point) melted by an energy source, either a laser or electron beam for each method, respectively. The melted material forms a melt pool similar to welding, then rapidly cools to form solid metal structure. After an entire 2D layer is complete, new layers of powder are spread over the top. Upon completion, the component is removed from the unmelted powder and cleaned. Subsequent thermal processes, such as hot isostatic pressing, are often

utilized to remove any residual porosity or alter the metallic microstructure. However, these post-processes are increasingly being avoided or are not needed. Other relevant metal AM techniques include laser-directed energy deposition, which does not require a powder bed but rather ejects powder out of a nozzle that is coincident with the laser, and electron beam wire AM, which uses a wire based feedstock and an electron beam to melt the material. Some of these other techniques also offer promise for in-situ repair of fusion reactor components.

AM is a rapidly accelerating field which can be leveraged by the fusion energy community for both improvements and discovery of (new) plasma-facing materials. A fundamental new concept associated with AM of metals is for the material, and consequently its microstructure, to be formed at the same time the part is being created; aspects of material synthesis and manufacturing are thus now occurring simultaneously. This is both an opportunity and potential drawback. The opportunity is that there may be an ability to locally tailor the microstructure within a single component through manufacturing process parameters. While this capability is still emerging, the design of microstructure by varying energy source (laser or e-beam) power and speed to control heating and cooling rates in the melt pool (typically these are $>10^4$ °C per second) has been demonstrated. The drawback of this potential capability is that it may result in a more difficult qualification and certification process. Whereas material qualification and part certification previously were two

separate processes, they have now been conflated. However, the potential benefit to fusion reactors is clear. The ability to create locally tailored materials would have multiple applications in fusion energy.

A second advantage of metal AM for fusion energy systems is the ability to create complex structures never before possible with conventional methods. This fundamentally changes how we would design important components such as divertors and heat exchangers. Complex lattice, or composite structures for lightweight-yet-strong components become plausible (e.g. [Figure 3](#)), as do triply periodic minimal surfaces like gyroids that may be ideal for heat exchangers. This newfound ability to create complexity radically opens the design space in ways that we may not even be able to conceive at this time.

Novel Technologies for Tritium Fuel Cycle Control

Summary. Because D-T fusion power plants must produce their own tritium fuel, innovative concepts for fuel production, fuel extraction, and fuel reprocessing show clear transformative potential. In fuel production, several blanket technologies will enable significantly higher thermal-to-electrical efficiency in generating tritium within the blanket. Both increases will significantly reduce fusion plant operating costs. In fuel extraction, several new tritium extraction technologies proposed for liquid metal breeding blankets and plasma facing components promise very high extraction efficiencies that will maximize plant performance

and safety. Finally, in fuel processing, a key technology has the potential to simultaneously decouple plasma and tritium plant operation and reduce the size and inventory of the tritium plant by ~75%.

Future fusion reactor power plants will consume unprecedented quantities of tritium, approximately 100-150 kilograms every year for a typical gigawatt-scale electrical power plant³¹. This tritium must be produced by the reactor plant itself through neutron-lithium nuclear transmutation reactions in a *breeding blanket* surrounding the thermonuclear fusing plasma. The blanket assembly is also the main heat transfer system and must operate at very high temperatures (near 700 °C) to maximize power conversion efficiency and ensure a competitive cost of electricity. The extraction and processing systems for this rate of tritium production will exceed those required by ITER by more than a factor of four³². The large production rate and associated storage inventory, coupled with the rapid mobility of tritium through most structural materials at these temperatures, will require technological capabilities well beyond those planned for ITER to guarantee plant safety, reliability, and low environmental impact. The production, extraction and processing of tritium constitutes a grand challenge for all currently-envisioned nuclear fusion-powered electrical plants³³. Technologies that address these specific challenges and show favorable potential for transforming the vision and promise of fusion power include:

- *Tritium fuel production:* Of the blanket technologies presented, two stood out as enabling significantly higher thermal to electrical efficiency (η_{th}) and tritium breeding ratio (TBR). The *dual-coolant lead lithium (DCLL) blanket* (Figure 4) was identified as having the potential for producing one of the highest η_{th} ($\geq 45\%$) and TBR of any blanket concept to date. The TBR in this concept can also be adjusted dynamically during operations to optimize use and storage. *Cellular-Ceramics*, for solid breeding media applications, also hold promise for significantly higher TBR and working-fluid temperature through high precision control of porosity, composition, and other design elements. Successful development of this technology would also address unresolved ceramic pebble bed blanket sintering problems.
- *Tritium fuel extraction:* Liquid metal (LM) breeding blankets have the greatest potential for producing high-efficiency fusion power reactors. To achieve this goal, these reactors need tritium extraction technologies that can process the entire LM flow at high temperatures and with high extraction efficiencies ($> 80\%$) in order to maximize plant performance and safety. LM tritium extraction technologies presented to the panel that meet these criteria fell into two types: *electrolytic membrane extraction* and *permeable membrane extraction* methods.
- *Tritium fuel processing:* A driver for a reactor's fueling plant tritium inventory and processing flowrate is the plasma's tritium burn

fraction (TBF). A key technology presented to the panel that has the potential for simultaneously decoupling plasma and tritium plant operation, reducing the size and inventory of the tritium plant by 75%, reducing the demand on a reactor cryoplant and providing steady state vacuum vessel pumping operation is the “*superpermeable*” metal foil pump (MFP).

Development of these technologies is driven exclusively by fusion applications, so the transformation will have to come from the fusion community. The necessary eventual involvement from industry is a challenge due to the lack of demand for non-fusion uses and the long time before the fusion applications will require industrial-scale production. For the other TECs, developments can result in advancements for near-term facilities, while these fuel cycle technologies will only demonstrate their effectiveness in a power plant. However, the technologies presented here not only provide a necessary function for such a power plant, but also have the potential to increase the efficiency, improve the safety, and reduce the regulatory burden, which could bring a power plant to reality more quickly.

Second Tier Transformative Enabling Capabilities

Fast flowing Liquid Metals

Summary. Fast flowing liquid metal plasma facing components may prove to be an attractive alternative to handle both high steady-state and transient plasma heat flux in a fusion reactor power plant, which would revolutionize control of the plasma-material interface. Liquid metals continually replenish material and are self-healing, eliminating concerns for the lifetime of solid materials, which erode with constant plasma bombardment. In addition, certain liquids, e.g. lithium, can strongly improve plasma confinement and lead to smaller, more economical reactor designs. There are however, several important knowledge gaps in these systems, including managing the tritium fuel retention, maintaining clean surfaces for reliable flow, counteracting mass ejection forces, determining operating temperature windows, and demonstrating helium ash exhaust. Given these gaps and the modest industrial investment in fast flow liquid metals for other tasks, this line of research was evaluated as a Second Tier TEC, i.e. “potentially transformative.”

Liquid-metal (LM) PFCs may be the only concept capable of tolerating both high steady and transient heat flux in the high-duty cycle and extreme-environment of a fusion reactor power plant, due to the capability of such PFCs to continually replenish material. The possible use of LM as PFCs is shown schematically in [Figure 5](#). In addition, liquid PFCs can provide access to low recycling (in the case of lithium), high confinement regimes, e.g. at > 2 times H-mode scaling laws, around

which attractive fusion scenarios can be operated¹. Free-surface LM systems have been considered to both mitigate erosion and handle large high heat-flux power exhaust from tokamak devices. These systems have also been proposed for application to reactor-level fusion plasmas, which will experience considerable neutron damage, He-ash exhaust and high-duty cycle constraints on solid PFCs (plasma-facing components), ultimately generating several tons of eroded material per year of operation. Because flowing LM systems are self-replenishing, they could remove some drawbacks of solid PFCs. While impurity emission from the liquid surface to the plasma and neutron damage to the existing substrate in the PFC would remain major challenges, flowing LM systems may be able to address the continual erosion/redeposition conditions at the plasma edge. However, for the case of low-recycling LM surfaces, the promise of low-recycling regimes and high retention of hydrogen isotopes is tempered by the challenge of possible tritium uptake and the need for advanced technologies for tritium removal from LM candidate materials, such as lithium or tin. Additional knowledge gaps for LM PFCs include keeping the surfaces clean for reliable flow, counteracting MHD mass ejection forces and possible dry-out scenarios with the underlying substrate, determining operating temperature windows, and demonstrating He ash exhaust. Given the well-known knowledge gaps, the “high payoff” is not yet fully confirmed, while the risk remains high. In addition, the lack of a broad external technology industry driver means that progress requires substantial dedicated resources; for these

reasons, the class of fast free-flowing LM concepts is evaluated as “potentially transformative.” On the other hand, industrial involvement could accelerate innovation and commercialization of these technologies; indeed, commercial sector contributions may be a necessary step to realization of this technology in a power plant.

Summary

Each of these TECs:

- Advanced algorithms (Tier 1)
- High critical temperature superconductors (Tier 1)
- Advanced materials and manufacturing (Tier 1)
- Novel technologies for tritium fuel cycle control (Tier 1)
- Fast flowing liquid metal PFCs (Tier 2)

presents a tremendous opportunity to accelerate fusion science and technology toward power production. Dedicated investment in these TEC areas for fusion systems is needed to capitalize on the rapid advances being made for a variety of non-fusion applications, to fully realize their transformative potential for fusion energy. Moreover realization of advances in multiple TECs would be synergistic to enable attractive, new reactor designs.

Acknowledgements

This paper is a summary of the full FESAC Transformative Enabling Capabilities (TEC) panel report. The full report is available on the DoE

Fusion Energy Sciences webpage at https://science.energy.gov/~media/fes/fesac/pdf/2018/TEC_Report_1Feb20181.pdf. The authors acknowledge excellent guidance provided by Dr. Don Rej, FESAC chair, Prof. Steve Knowlton, FESAC vice-chair, and Dr. Sam Barish, FES liaison.

Control Operating Regime Map

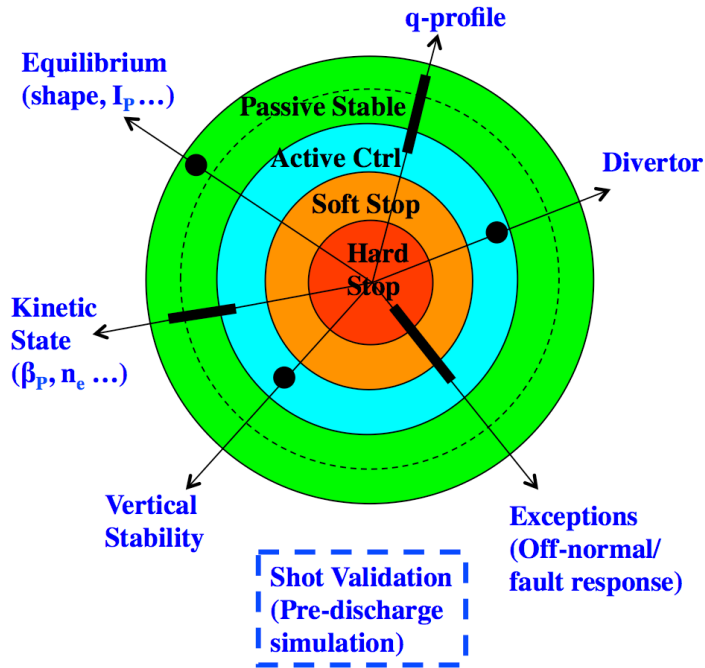

Figure 1: a state-of-the-art control operating space of a tokamak illustrates the level of operational controllability (colored concentric layers representing Passive, Active, or Shutdown control) corresponding to each control category (represented by blue text labels). In an extreme fault the controllability may become so poor that the device must be shut down in a controlled way (Soft Stop) or in an emergency termination (Hard Stop).

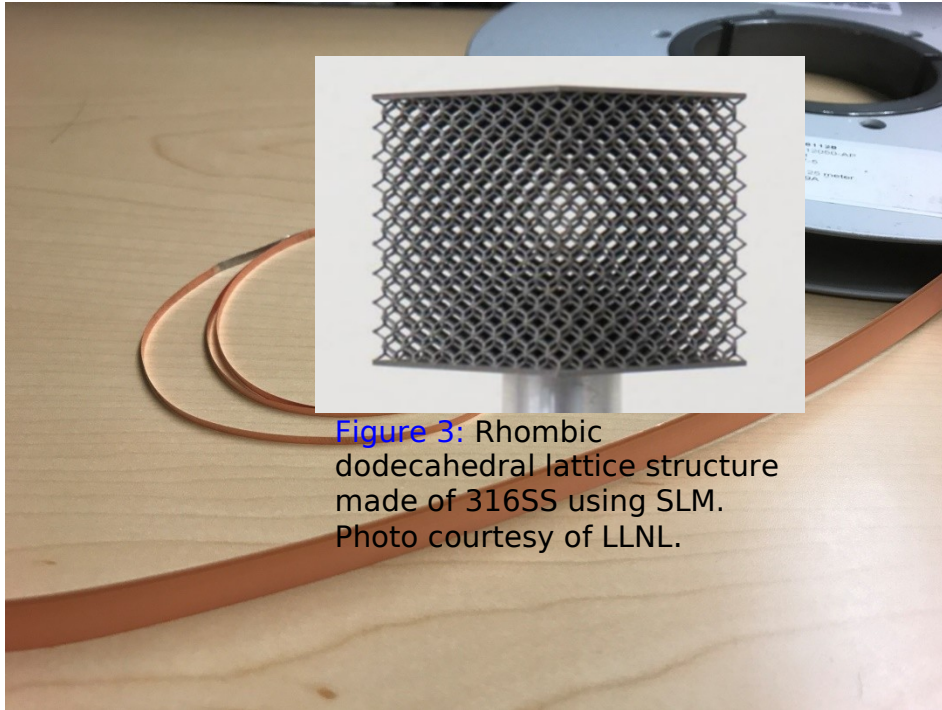

Figure 3: Rhombic dodecahedral lattice structure made of 316SS using SLM. Photo courtesy of LLNL.

Figure 2: two commercial tapes from SuperPower: 12 mm wide, 100 μm thick tape and 2 mm wide, 45 μm thick tape.

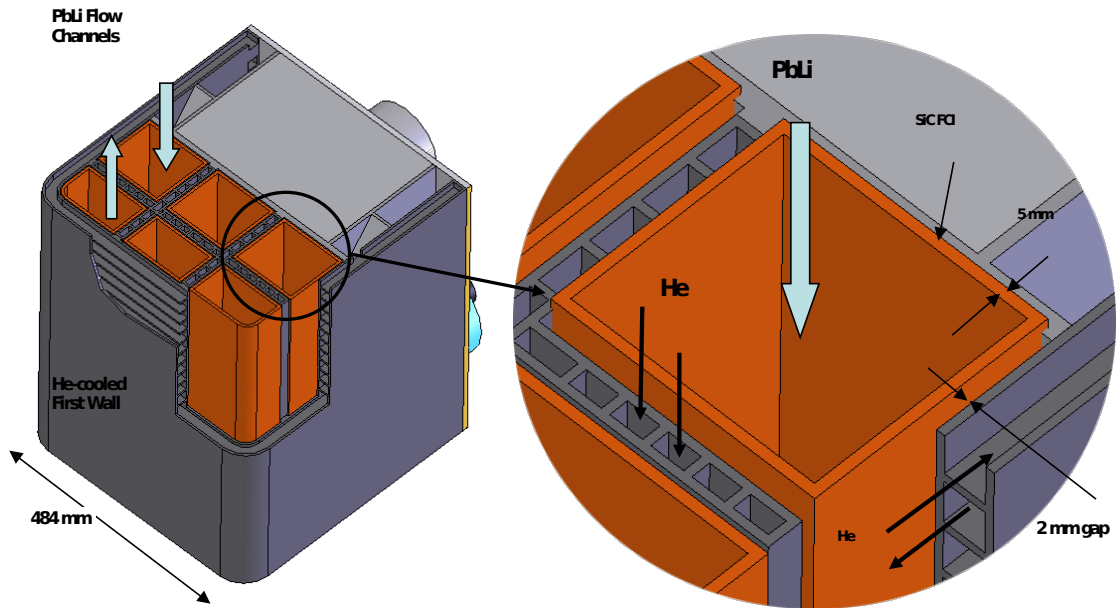

Figure 4: schematic representation of Dual Coolant Lead Lithium blanket

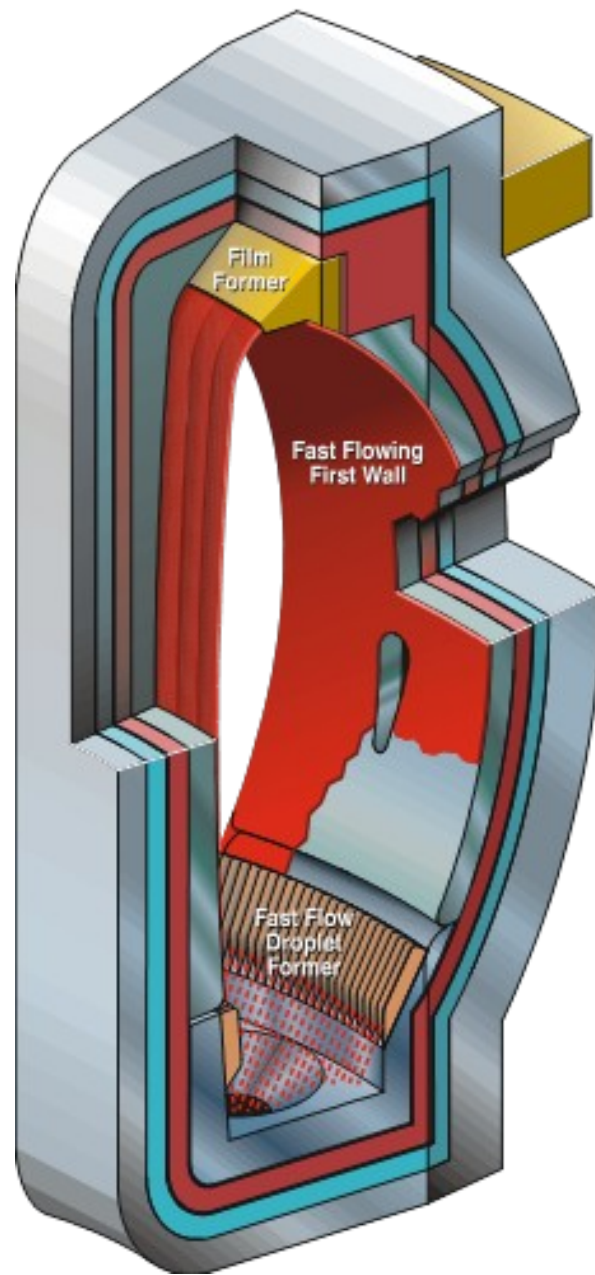

Figure 5: CLIFF Convector Liquid Flow First wall
N.B. Morley *et al.*, <http://slideplayer.com/slide/4939850/>

References

1. J. M. Maciejowski, 1989 *"Multivariable Feedback Design," Addison-Wesley, Wokingham, England*
2. N. Eidietis, 2017 *"Transformative Disruption/Mitigation Solutions," TEC whitepaper*
3. E. Kolemen, 2017 *"Real-time stability analysis and control for disruption-free operations", TEC whitepaper*
4. A. Scheinker, 2017 *"Adaptive feedback control for automated plasma diagnostics and control systems", TEC whitepaper*
5. J. Schneider, 2017 *"Machine learning, artificial intelligence, and robotic reasoning", TEC presentation*
6. E. Schuster, 2017 *"Reactor-like Control integration by model-based real-time optimization", TEC whitepaper*
7. K. P. Murphy, 2012 *"Machine Learning: A Probabilistic Perspective", MIT Press, Cambridge, MA*
8. R. Granetz, 2017 *"Machine Learning methods applied to disruption prediction," TEC whitepaper*
9. A. Constantinou, 2016 *Artificial Intelligence in Medicine* **67** 75
10. D. Ferrucci, 2013 *Artificial Intelligence* **199** 93
11. S. J. Russell, 2014 *Artificial Intelligence: A Modern Approach,* Pearson Education, Essex, UK
12. A. Saxena, 2016 *"How AI Can Automate Our Lives," Structure Data Conference 2016;* <https://vimeo.com/159939784>
13. 2016 *Science* **354** 426
14. 2017 *"AI is Changing How We Do Science," Science Online,* doi: 10.1126/science.aan7049
15. E. Putin, *"Deep biomarkers of human aging: Application of deep neural networks to biomarker development",* <http://pubs.acs.org/doi/abs/10.1021/acs.molpharmaceut.6b00248>
16. L. Reusch, 2017 *"Developing integrated data analysis techniques to optimize diagnostics for burning plasmas", TEC whitepaper*

17. M. Churchill, 2017 "Accelerating fusion science with an end-to-end analysis framework for remote, large-scale, near real-time analysis," *TEC whitepaper*
18. D. Humphreys et al., 2015 *Phys. Plasmas* **22** 021806
19. J. A. Snipes et al., 2017 *Nucl. Fusion* **57** 125001
20. S. Awaji, 2017 *Supercond. Sci. Technol.* **30** 065001
21. B. N. Sorbom et al., 2015 *Fusion Eng. Des.* **100** 378
22. M. Putti, 2010 *Supercond. Sci. Technol.* **23** 034003
23. W. H. Fietz, 2013 *Fus. Eng. Des.* **88** 440
24. D. Larbalestier, 2001 *Nature* **414** 368
25. S. Y. Hahn, 2017 *Presented at MT25, Sept. 2017* to be published
26. V. Selvamanickam, 2017 *Presented at the Low Temperature and High Field Superconductor Workshop, Santa Fe, NM, February 2017*
27. H. W. Weijers, 2016 *IEEE Trans. Appl. Supercond.* **26** 4300807
28. C. Barth, G. Mondonico, and C. Senatore, 2015 *Supercond. Sci. Technol.* **28** 045011
29. J. Emhofer, M. Eisterer, and H. W. Weber, 28 *Supercond. Sci. Technol.* **26** 035009
30. R. Prokopec, 2014 *Supercond. Sci. Technol.* **28** 014005
31. L. El-Guebaly, 2017 "Neutronics and Tritium Breeding Capability for Liquid Metal-Based Blanket (DCLL)", *TEC whitepaper*
32. C. Day, and T. Giegerich, 2013 *Fus. Eng. Des.* **88** 616
33. A. C. Klein, 2017 *American Nuclear Society special report* 3