

UC San Diego

San Diego Linguistic Papers, Issue 4

Title

Non-Intervocalic Gemimates: Typology, Acoustics, Perceptibility

Permalink

<https://escholarship.org/uc/item/2bb4829q>

Author

Bozena, Pajak

Publication Date

2013-12-15

Non-Intervocalic Geminate: Typology, Acoustics, Perceptibility

Bozena Pajak

University of California, San Diego*

1. Introduction

Geminate consonants in different contexts (defined in terms of word position and adjacent segments) are not evenly distributed cross-linguistically. Intervocalic geminates are the most common (Thurgood 1993) and non-vowel-adjacent geminates are the most rare (Thurgood 1993, Muller 2001). This paper provides experimental evidence that this typological pattern has some basis in perception: the geminate-singleton contrast is easiest to perceive in the intervocalic context and hardest in the non-vowel-adjacent environment.

Phonetically, geminates are usually described as long consonants, but their relative duration with respect to their singleton counterparts differs from language to language. Based on a cross-linguistic survey, Ladefoged and Maddieson (1996) report that in careful speech geminates can be on average between one-and-a-half and three times as long as singletons.¹ Many languages use consonant length contrastively, as illustrated by minimal pairs such as ‘bello’ – ‘belo’ (‘beautiful’ – ‘I bleat’) from Italian, or ‘takka’ – ‘taka-’ (‘fireplace’ – ‘back’) from Finnish.² Listeners are usually assumed to rely on a variety of cues in addition to duration, such as differences in burst, voice onset time (VOT), amplitude, etc. (Lahiri & Hankamer 1988, Amramson 1986, Amramson 1992, Amramson 1999, Arvaniti 1999, 2010, Muller 2001).

Phonologically, geminates have been represented, for example, as consonants that have two timing slots (e.g., Levin 1985, Selkirk 1991, Tranel 1991, Hume, Muller, & Engelenhoven 1997), a single mora projection (e.g., Hyman 1985, Hayes 1989, Davis 1999), or a combination of the two (Muller 2001). Additionally, it has been argued that geminates in different word positions may have distinct representations, even within the same language (Goodman 1995, Davis 1999, Ham 2001, Topintzi 2006, Topintzi 2008). Finally, geminates that arise through morpheme concatenation have often been referred to as ‘fake’ geminates, and represented as two adjacent identical segments (Kenstowicz 1982, Hayes 1986). For the purposes of this paper, no explicit position is taken with respect to the phonological representations of geminates. All geminates are discussed regardless of their representation.

Geminates can be classified by taking into account their *context*, which is defined here in terms of their word position and adjacent segments. The importance of these two factors in analyses of geminate consonants has been pointed out by Muller (1999), McCrary (2002, 2004), and Pajak (2009). Muller argues that distinct constraints target geminates in different *word positions* in

* Present affiliation: University of Rochester, Center for Language Sciences, email: bpajak@bcs.rochester.edu.

- 1 Longer duration might not be a universal characteristic of geminates. Bothorel (1999, as reported by Thurgood 1993) states that in Breton (Argol) the total duration of geminates and their singleton counterparts is approximately the same, but geminates display a longer steady state, which gives the impression of higher intensity. However, it seems fairly controversial whether such consonants can in fact be considered geminates.
- 2 Examples from on-line dictionaries: <http://www.wordreference.com/iten> (Italian) and <http://www.fincd.com> (Finnish).

Chuukese. McCrary proposes that the constraints on geminates in Italian need to take into account their *adjacent segments*. Finally, Pajak shows how the combination of the two factors correctly accounts for the distribution of geminates in Polish.

Cross-linguistically, geminates are most commonly found in the intervocalic context (Thurgood 1993). In fact, there are languages, such as Ancient Greek (Steriade 1982), Japanese (Kawahara 2005), Luiseño, or Hopi (Crothers, Lorentz, Sherman, & Vihman 1979, Thurgood 1993), which allow geminates exclusively in this environment. In contrast, non-vowel-adjacent geminates are extremely rare (Thurgood 1993, Muller 2001). In an informal survey of 40 languages that use geminates contrastively³, only 4 languages with non-vowel-adjacent geminates were found⁴: Moroccan Arabic, Swiss German, Yapese, and Berber⁵.

Therefore, the typological evidence suggests that there is a strong preference for intervocalic geminates, and a dispreference for non-vowel adjacent geminates, as shown in (1). Some examples of each type of geminates are shown in (2).

- (1) *Geminates: typological scale of preference (GG=geminate, C=consonant, V=vowel)*
- | | | | | |
|--------------|---|------------------------|---|--------------------|
| intervocalic | > | single vowel-adjacent | > | non-vowel-adjacent |
| VGGV | | #GGV, VGG#, VGGC, CGGV | | #GGC, CGG#, CGGC |

(2) *Geminates in different contexts*

a. Intervocalic (medial)

[fatto]	‘fact’	<i>Italian</i>	(Loporcaro 1996: 125)
---------	--------	----------------	-----------------------

b. Single vowel-adjacent (initial, medial, or final)

[ppefto]	‘I fall’	<i>Cypriot Greek</i>	(Arvaniti 1999: 23)
----------	----------	----------------------	---------------------

[tanggap]	‘date’	<i>Taba</i>	(Bowden 2001: 39)
-----------	--------	-------------	-------------------

[ʔimm]	‘mother’	<i>Palestinian Arabic</i>	(Salim 1980: 6)
--------	----------	---------------------------	-----------------

c. Non-vowel-adjacent (initial, medial, or final)

[ttlata]	‘Tuesday’	<i>Moroccan Arabic</i>	(Heath 1987: 38)
----------	-----------	------------------------	------------------

[fqqs]	‘irritate’	<i>Tashlhiyt Berber</i>	(Ridouane 2008: 332)
--------	------------	-------------------------	----------------------

[tfss]	‘she is quiet’	<i>Tashlhiyt Berber</i>	(Ridouane 2008: 332)
--------	----------------	-------------------------	----------------------

Furthermore, the following implication is true for the vast majority of languages: if a language has non-intervocalic geminates, it also has intervocalic ones (Thurgood 1993). The only potential counterexamples to this generalization are languages which seem to allow word-initial geminates,

3 The survey was based primarily on the data from Muller (1999), supplemented by consulting the original sources cited by Muller, as well as by data from Hayes (1986), Harrikari (1999), Ham (2001), Kawahara (2005), Loporcaro (1996), Leslau (1995), Ridouane (2008), Spaelti (1994), Steriade (1982), and Thurgood (1993). The languages included in the survey were chosen from several different regions and language families: *Indo-European* (Breton, Bernese Swiss, Swiss German, Italian, Polish, Ancient Greek, Cypriot Greek), *Caucasian* (Circassian, Lak), *Uralic* (Finnish, Hungarian), *Afro-Asiatic* (Amharic, Cypriot Maronite Arabic, Levantine Arabic, Moroccan Arabic, Tamazight & Tashlhiyt Berber), *Nilo-Saharan* (Lugbara), *Niger Congo* (Luganda), *Austro-Asiatic* (Nhaheun), *Austronesian* (Chuukese, Dobel, Kiribati, Leti, Madurese, Ngada, Pattani Malay, Ponapean, Puluwat, Roma, Sa’ban, Taba, Woleaian, Yapese), *West Papuan* (Hatam), *Japonic* (Hatoma, Japanese), *Uto-Aztekan* (Hopi, Luiseño), *Oto-Manguan* (Atepec Zapotec), and *Arawakan* (Piro).

4 Smeets (1984) notes that clusters such as [p-pč] or [t-tx] are possible in Circassian. However, it is unclear from the description whether they can occur word-initially (which would mean that the geminates can be non-vowel-adjacent).

5 It is possible that non-vowel-adjacent geminates in Berber are tolerated only because Berber allows vowelless syllables, even with obstruents as syllable nuclei (Dell & Elmedlaoui 1985, Dell & Elmedlaoui 1988, Ridouane 2008).

but not medial intervocalic ones, such as Pattani Malay, Iban, Sa'ban (Austronesian), or Nhaheun (Austro-Asiatic) (Blust 1995, 2007, Muller 2001). However, there are explanations for the exceptionality of these cases. Initial gemimates (or gemimates in general) in many Austronesian languages (such as Pattani Malay or Iban) were created by a widespread diachronic process of vowel syncope between two identical consonants, which was motivated by a preference for disyllabic canonical shape (Blust 2007). In Sa'ban, initial gemimates arose through a general process of unstressed vowel deletion in penultimate syllables (Blust 2001, 2007). In Nhaheun, on the other hand, most words are monosyllabic, which precludes any generalization concerning possible medial gemimates (Muller 2001).

The question remains as to why non-intervocalic gemimates are avoided. An obvious answer might invoke phonotactics: non-intervocalic gemimates could be cross-linguistically avoided due to common restrictions on size and/or sonority sequencing of clusters. However, this does not seem to be the case. There are languages with very permissive phonotactics, which nonetheless avoid non-intervocalic gemimates. For example, Polish allows up to five consonants in a cluster (e.g., Bethin 1992), which often violate the Sonority Sequencing Principle (Hooper 1976, Kiparsky 1979, Steriade 1982, Selkirk 1984, Clements 1990, Zec 1995, among others). At the same time, it only tolerates intervocalic gemimates and – with certain restrictions – initial gemimates followed by a vowel (Rubach 1986, Pajak 2009). The example of Polish indicates that while phonotactics certainly play some role, it seems that other factors must also be involved in the avoidance of non-intervocalic gemimates.

The hypothesis tested in this paper is that the context-dependent preference scale of gemimates has some basis in perception. Non-intervocalic gemimates are dispreferred because they are perceptually less salient, and factors that diminish their perceptibility include non-medial word position and adjacency to consonants.

This hypothesis is based on the body of research related to perceptibility of contrasts. Typologically less common contrasts are those that tend to be perceptually less salient (Narayan 2006, Kawahara 2007, among others). Perceptual saliency can be intrinsic to segments, but is also mediated by environment (Côté 2000, Hume 2001, Steriade 2001). This idea has also been applied directly to gemimates. McCrary (2004) argues that gemimates in Italian appear in an environment where the geminate-singleton contrast is saliently perceived. Steriade (2008) speculates that medial gemimates followed by a consonant are highly confusable with singletons because consonants in clusters undergo shortening. However, Steriade bases this claim on Haggard's (1973) and Klatt's (1973) studies of English clusters, and their observation that durations of several sonorant and obstruent consonants (in both onsets and codas) are shorter when they are in clusters than when they occur as single consonants. It is unclear whether this effect would actually apply to geminate consonants. Finally, Kawahara (2007: fn 16) suggests that word-initial (vs. medial) position might decrease the perceptibility of the [ss]~[s] contrast. However, this last claim so far lacks empirical evidence.

The results of three experimental studies are reported in this paper. The studies were aimed to test the hypothesis that the context-dependent preference scale of gemimates is based in perception. The first step, discussed in §2, involves investigating the acoustics of gemimates (alveolar fricatives [ss] and [zz]) in different contexts: intervocalic, single vowel-adjacent, and non-vowel-adjacent (experiment 1). The target language chosen for the experiment was Moroccan Arabic, due to the fact that it is one of the few languages that allow gemimates even in the most marked contexts. In §3 and §4, two perception studies are discussed, in which non-native listeners (native speakers of English) were tested on discrimination of the Moroccan Arabic geminate-singleton contrast. The participants were either not familiar with any length contrasts in any other language (experiment 2), or they spoke another language that uses length

contrastively (e.g., Korean, Japanese, Italian, etc.).

Note that in order to test the universality of the geminate preference scale, the perception study could not be performed on native listeners. In fact, there is evidence that speakers' perception of geminates in their native language is not impaired in non-intervocalic contexts. Muller (2001) has shown that native speakers of Cypriot Greek are equally good at identifying medial intervocalic and initial single vowel-adjacent geminates. These results suggest that – even if the geminate preference scale has a perceptual basis – the geminate-singleton contrast can be successfully learned, independently of the environment, just as any other phonetic distinction that is used contrastively in a particular language.

Instead, the perception experiment (experiment 2) was performed on native speakers of English, who have had a very limited exposure to the geminate-singleton contrast. Phonetically long consonants are attested in English intervocalically at morpheme junctures (e.g., 'dissatisfied,' 'vowelless' or 'big game'; Benus, Smorodinsky, & Gafos 2003). However, English geminates are limited to very specific contexts (at stem-affix and compound boundaries), there are no lexical minimal pairs where the geminate-singleton contrast would be present, and this phonetic length is not consistent across speakers. Furthermore, there is evidence that by 18 months of age English-learning infants process duration contrasts differently from infants learning a language that contrasts duration (e.g., Dutch or Japanese; Dietrich, Swingley, & Werker 2007; Mugitani, Pons, Fais, Werker, & Amano 2008). Therefore, it is assumed that English native speakers are not accustomed to paying attention to the geminate-singleton *contrast*, even though they might have had exposure to phonetically long consonants.

Experiment 3 was designed to test whether the same context-dependent perceptual pattern holds for non-native listeners who are nevertheless familiar with length contrasts in other languages. It was expected that the performance in this group would be overall better than in experiment 2, but – if non-intervocalic geminates are intrinsically perceptually less salient – the discriminability of the geminate-singleton contrast should be better in intervocalic than in non-intervocalic contexts. That the pattern of responses should be similar for listeners who are either familiar or not familiar with length contrasts is suggested by Dmitrieva's (2010) work, which shows that the perceptual boundary between Russian geminates and singletons is similar for native Russian and native English speakers.

2. Experiment 1: Acoustic Analysis

The objective of the first experiment was to investigate the acoustic properties of geminates and their singleton counterparts in different contexts. In particular, the cue of interest was segmental duration. The main point was to uncover any potential differences between contexts where both word position and adjacent segments are manipulated. A native Moroccan Arabic speaker was recorded for the purposes of this study.

2.1 Method

2.1.1 Materials

The materials consisted of nonce words that contained phonotactically legal sequences in Moroccan Arabic. Four different *contexts* were created by taking into account two factors: (i) *word position*: medial vs. initial, and (ii) *following segment*: vowel vs. consonant. This procedure yielded the following contexts: medial+V, medial+C, initial+V, and initial+C, as shown in (3). In each context, the tokens were of one of two *types*: geminate or singleton. The test tokens were limited to the alveolar fricatives [ss]/[s] and [zz]/[z]. The vowel [a] was kept constant in all the

tokens (both test words and fillers). The obstruents [t] and [d] were chosen for the consonants following the geminate/singleton.

(3) *Test tokens in 4 conditions*

Word position	Following segment	
	V	C
medial	[assa:]~[asa:] [azza:]~[aza:]	[assta:]~[asta:] [azzda:]~[azda:]
initial	[ssa:]~[sa:] [zza:]~[za:]	[sstta:]~[stta:] [zzzda:]~[zda:]

Throughout the paper the tokens with fricatives in medial position are referred to as ‘medial,’ and those with fricatives in initial position as ‘initial.’ Similarly, the terms ‘+V’ and ‘+C’ tokens are used for the cases where the fricatives are followed by a vowel or a consonant, respectively. Finally, the terms ‘geminate’ and ‘singleton’ tokens are used to refer to the two different types of tokens.

The target words were placed in the following carrier sentence:

- (4) aqu:l _____ marra xra
‘I say _____ once again’

Both the target words and the carrier sentence were written in Arabic. The geminate consonants were indicated by the *shadda*, a diacritic commonly used in the Arabic writing system to mark geminate consonants. The final vowels were written with an *alif*, which usually indicates a long vowel. It was decided to use long final vowels in order to make sure that stress was the same for all the tokens (i.e., word-final stress). Without the final long vowel, the ‘medial’ tokens would have been stressed on the first syllable, yielding post-stress gemimates. On the other hand, the ‘initial’ tokens would have been composed of pre-stress gemimates. Since such stress differences can affect the duration of geminate consonants (Payne 2000, 2005, Payne & Eftychiou 2006), this factor was maintained constant.

The test words were organized in seven randomized lists. Each list contained all of the test tokens plus fillers in the approximate proportion of 1:2 for the first recording session, and 1:1 for the second and third sessions.

2.1.2 *Recordings*

The recordings took place in the sound-proof booth in the Center for Research on Language at the University of California, San Diego. There were three recording sessions: the first two were scheduled approximately one week apart, and the third one about two months afterwards. In each session, a male native speaker of Moroccan Arabic, currently living in the U.S, was asked to read aloud the test materials presented on paper (seven randomized lists). The speech was recorded to a PC at 44.1 Hz sampling rate using the Adobe Audition 3.0 software. The speaker was instructed to read the sentences as naturally as possible, and to repeat any misread sentences. He was monitored during the whole session in order to ensure proper recording and performance.

2.1.3 Acoustic measurements

The first repetition of the list in each session was discarded from analysis, yielding a total of 36 repetitions for each test condition (18 ‘voiceless’ and 18 ‘voiced’), counted separately for ‘geminate’ and ‘singleton’ tokens. All the measurements were made using the Praat speech analysis program (Boersma & Weenink 2008) by creating a waveform and a spectrogram of each token. The durations of fricatives and vowels were marked on each file using TextGrids, and subsequently extracted to an Excel file for statistical analysis.

The onset of the fricatives was assumed to be the point of appearance of high amplitude aperiodic noise. The offset was assumed to be the point of appearance of regular formants for prevocalic fricatives, and the beginning of closure for preconsonantal fricatives.

The vowel boundaries were determined by the presence of a periodic wave and regular formants.

2.2 Results

2.2.1 Fricative duration

The durations of fricatives were log-transformed for the purposes of the analysis, and statistically analyzed by means of a repeated measures ANOVA on the variables *type* (‘geminate’ or ‘singleton’), *position* (‘medial’ or ‘initial’), *following segment* (‘+V’ or ‘+C’), and *voicing* (‘voiceless’ or ‘voiced’). The results are illustrated in Figure 1.

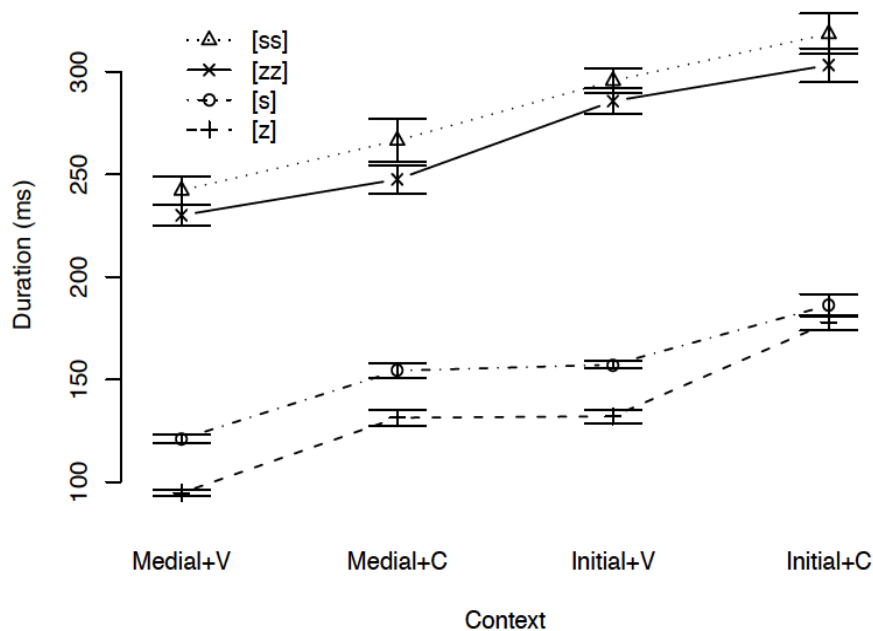

Figure 1: Mean durations of singleton and geminate fricatives in Moroccan Arabic (error bars represent standard error of the mean).

The differences between variable levels were compared through planned comparison tests. All the variables showed significant effects: *type* [$F(1,17)=3923.1$; $p<.001$], *position* [$F(1,17)=287.3$;

$p < .001$], *following segment* [$F(1,17)=118.6$; $p < .001$], and *voicing* [$F(1,17)=88.1$; $p < .001$].

Geminate alveolar fricatives in Moroccan Arabic were found to be on average twice as long as singletons. However, their duration changed depending on the context: they were the shortest in the intervocalic environment and the longest word-initially when followed by a consonant. Furthermore, voiceless fricatives were longer than voiced fricatives in all contexts.⁶

Significant interactions were found between *type* and *position* [$F(1,17)=7.4$; $p < .05$], *type* and *following segment* [$F(1,17)=37.4$; $p < .001$], as well as *type* and *voicing* [$F(1,17)=18.8$; $p < .001$]. This result indicates that the difference in duration between geminates and singletons is a function of context and voicing. Another way of looking at this result is that the mean geminate/singleton *duration ratio* is different depending on the segment and the environment, and ranges from 1.7 to 2.4, as shown in (5).

(5) *Geminate/singleton duration ratios*

Context	Voicing	
	[zz]/[z]	[ss]/[s]
medial+V	2.4	2.0
initial+V	2.2	1.9
medial+C	1.9	1.7
initial+C	1.7	1.7

2.2.2 *Vowel duration*

A repeated measures ANOVA was used to analyze the (log-transformed) durations of vowels, both initial and final. It was performed on the variables *type* ('geminate' or 'singleton'), *position* ('medial' or 'initial'), *following segment* ('+V' or '+C'), and *voicing* ('voiceless' or 'voiced').

For the duration of the final vowel, there was a main significant effect of all the variables:

- ▲ *type* [$F(1,17)=23.0$; $p < .001$]: the vowel was longer for 'singleton' than 'geminate' tokens;
- ▲ *position* [$F(1,17)=17.9$; $p < .001$]: the vowel was longer for 'initial' than 'medial' tokens;
- ▲ *following segment* [$F(1,17)=23.8$; $p < .001$]: the vowel was longer for '+V' than '+C' tokens;
- ▲ *voicing* [$F(1,17)=40.7$; $p < .001$]: the vowel was longer for 'voiced' than 'voiceless' tokens.

Additionally, there were significant interactions between *type* and *position* [$F(1,17)=13.4$; $p < .01$], as well as between *position* and *following segment* [$F(1,17)=6.4$; $p < .05$]. These interactions revealed that for the 'initial' tokens, the final vowel was longer for 'singletons' than for 'geminates.' For the 'medial' tokens there was no difference in final vowel duration between 'singletons' and 'geminates. Additionally, for the 'initial' tokens, the final vowel was longer for the '+V' tokens than for the '+C' tokens. For the 'medial' tokens no such difference was found.

For the duration of the initial vowel, there was a main significant effect of *type* [$F(1,17)=92.2$; $p < .001$] (longer for 'singleton' than 'geminate' tokens). There was no effect of *voicing* [$F=3.1$; $p=.1$] nor *following segment* [$F < 1$].

⁶ Similar differences are attested in fricatives in other languages: see e.g. de Manrique and Massone, 1981 for Spanish, and Baum and Blumstein, 1987 for English.

The results are summarized in (6).

(6) Mean vowel durations (ms)

Token		Duration of initial vowel	Duration of final vowel	
medial	geminate	[assa:]	78 (se=3)	268 (9)
		[assta:]	80 (5)	262 (11)
		[azza:]	80 (4)	297 (10)
		[azzda:]	85 (3)	293 (9)
	singleton	[asa:]	110 (6)	278 (7)
		[asta:]	101 (5)	269 (11)
		[aza:]	116 (5)	292 (13)
		[azda:]	108 (5)	285 (10)
initial	geminate	[ssa:]	n/a	281 (9)
		[ssta:]	n/a	264 (10)
		[zza:]	n/a	308 (11)
		[zzda:]	n/a	287 (11)
	singleton	[sa:]	n/a	316 (9)
		[sta:]	n/a	284 (9)
		[za:]	n/a	350 (12)
		[zda:]	n/a	313 (12)

2.3 Discussion

The acoustic analysis reveals that Moroccan Arabic long consonants [ss] and [zz] are about twice as long as the short consonants [s] and [z]. Additionally, the fricative durations appear to be shortest in non-intervocalic contexts, increasing along the geminate preference scale (medial+V > {initial+V, medial+C} > initial+C). Note, however, that this is the case for both geminates and singletons, which suggests that this phenomenon is not intrinsic to geminates. Initial fricatives might be lengthened due to prosodic boundary strengthening (e.g., Fougeron & Keating 1997). This, however, does not explain why the fricatives are also longer in the ‘medial+C’ than the ‘medial+V’ context. In fact, recall from §1 that according to Steriade (2001: 38) the opposite should be true: medial geminates followed by a consonant might be subject to the shortening-in-clusters effect. This claim has not been confirmed. Another possible explanation is that fricatives are lengthened in dispreferred contexts in an attempt to compensate for their lower perceptibility.

The most notable finding of the acoustic analysis is that the exact long-to-short fricative duration ratios change depending on the environment and the voicing of the segments. It is the highest in the intervocalic environment (2.2:1 on average) and the lowest word-initially when followed by a consonant (1.7:1 on average). Additionally, it is on average higher for voiced segments (2.1:1) than voiceless segments (1.8:1). Thus, the duration ratios *decrease* along the

geminate preference scale:

$$(7) \quad \begin{array}{ccc} \text{intervocalic} & < & \text{single vowel-adjacent} & < & \text{non-vowel-adjacent} \\ \text{ratio}=2.2 & & \text{ratio}=1.9 & & \text{ratio}=1.7 \end{array}$$

If perceptibility of geminates simply correlated with duration, then the ‘initial+C’ geminates should be the easiest to perceive and the ‘medial+V’ the hardest to perceive. However, the result regarding the geminate-singleton duration ratio points in the opposite direction, which is consistent with the proposed hypothesis. The ‘initial+C’ geminates should be the most confusable with their singleton counterparts because they are on average only 1.7 times as long as singletons, as opposed to ‘medial+V’ geminates which are on average 2.2 times as long as singletons.

As far as vowel duration is concerned, the main result is that the vowels are longer with ‘initial’ tokens than ‘medial’ tokens, as well as longer with ‘singleton’ tokens than ‘geminate’ tokens (the longer vowel is initial for the ‘medial’ tokens, and final for the ‘initial’ tokens). Thus, it is possible that vowel duration is an additional cue for native listeners in the discrimination of the consonant duration contrast.

3. Experiment 2: Perception by English Monolinguals

The second experiment was designed to test the hypothesis that the context-dependent geminate preference scale is based in perception. It consisted of a perception study, in which non-native listeners had to discriminate between geminates and singletons in different contexts: intervocalic (‘medial+V’), single vowel-adjacent (‘medial+C’ and ‘initial+V’), and non-vowel-adjacent (‘initial+C’). It was predicted that the participants would be best at hearing the geminate-singleton distinction in the intervocalic context, and worst in the non-vowel-adjacent context.

3.1 Method

3.1.1 Design

An AX discrimination task was designed to measure listeners’ capacity to perceive the geminate-singleton contrast in 4 contexts: ‘medial+V,’ ‘medial+C,’ ‘initial+V,’ and ‘initial+C’ (see table in (3)). Participants listened to ‘different’ (e.g., [assa:]~[asa:]) and ‘same’ (e.g., [assa:]~[assa:]) word pairs. The task was to decide whether they heard (i) two different words, or (ii) the same word repeated twice.

Each participant heard a total of 24 repetitions of each test condition (12 ‘voiceless’ and 12 ‘voiced’) by listening to 6 repetitions of an experimental block. Each experimental block consisted of 64 word pairs (32 test pairs + 32 fillers).

The experiment was prepared using the Praat software Boersma and Weenink, 2008, which randomized the pairs for every participant and every experimental block. The items within each pair were separated by an interstimulus interval (ISI) of 250ms. A short ISI of 250-500ms has been found to enhance listeners’ discrimination abilities of non-native contrasts in AX discrimination tasks (Werker and Tees, 1984; Werker and Logan, 1985). In addition, control versions of the experiment with ISIs of 500ms and 750ms were created in order to check whether this factor affects the overall result pattern.

3.1.2 Materials

The stimuli were built using the previously recorded tokens, as described in section 2. For each context (and ‘geminate’ and ‘singleton’ types separately), tokens were selected as follows: (a) 10

(out of the available 36) tokens where the duration of fricatives approximated mean duration (5 ‘voiceless’ and 5 ‘voiced’); (b) 10 (out of the available 36) tokens where the duration of vowels approximated mean duration (5 ‘voiceless’ and 5 ‘voiced’).

Due to the fact that in the recorded tokens geminates and singletons were associated with consistent differences in vowel durations (as discussed in §2.2 and §2.3), it is at least possible that non-native listeners could pick up on these differences in a controlled perception study, and rely on vowels – instead of consonant length – in order to complete the task. In order to control for this factor, the vowels and fricatives were spliced, and different combinations of spliced vowels and fricatives were created. First, the vowels were spliced out of the tokens and categorized as either ‘geminate’ (when extracted from a ‘geminate’ token) or ‘singleton’ (when extracted from a ‘singleton’ token), as shown in (8). The obstruents [t] and [d] in tokens such as [ssta:] were spliced out together with the vowels.

- (8) ss[a:]_G → ‘geminate’ vowel (i.e., vowel from a ‘geminate’ token)
 s[a:]_s → ‘singleton’ vowel (i.e., vowel from a ‘singleton’ token)

Subsequently, separately for each context, four different versions of *vowel type* were created by assembling different fricative+vowel combinations. This is illustrated in (9). *Vowel type* was a between-subject factor, which means that each participant heard tokens from only one *vowel type* condition.

(9) *The ‘vowel type’ conditions*

Condition	Example
'matching vowels'	ss[a:] _G ~ s[a:] _s
'non-matching vowels'	ss[a:] _s ~ s[a:] _G
'geminate vowels'	ss[a:] _G ~ s[a:] _G
'singleton vowels'	ss[a:] _s ~ s[a:] _s

In each *vowel type* condition, there were 20 different fricative+vowel combinations for each context (10 ‘voiceless’ and 10 ‘voiced’) and type (‘geminate’ and ‘singleton’).⁷ Each participant heard 16 of them throughout the experiment (each repeated 3 times), but different token pairings and order were used. In total, there were 10 different versions of the experiment for each *vowel type* condition. The high number of versions was created in order to control for random variation between tokens, and to make sure that the main perceptual effect is not due to any idiosyncratic properties of a given token.

The fillers were built to resemble the test tokens: they were either mono- or bisyllabic and only used the vowel [a]. Similarly to the test tokens, fillers consisted of both ‘different’ and ‘same’ pairs. The ‘different’ pairs can be divided into three categories: (i) voicing contrast (e.g., [aʃa:] ~ [aʒa:]), (ii) place contrast (e.g., [qla:] ~ [kla:]), and (iii) geminate/singleton contrast (e.g., [nna:] ~ [na:]).

A complete list of the stimuli is provided in the appendix.

⁷ Note that vowels extracted from ‘voiced’ tokens were never spliced together with voiceless fricatives (and vice versa).

3.1.3 Participants

There were 110 participants in this experiment. They were all undergraduate students at the University of California, San Diego. They received extra credit for their participation.

80 participants took part in the main part of the experiment (20 for each *vowel type* condition). They were native speakers of English with no previous exposure to a length-contrasting language (although most of them had studied a different second language at school, most commonly Spanish or French).

The additional ‘500ms’ version of the experiment was performed on 20 participants, and the ‘750ms’ version on 10 participants (all of them in the ‘matching vowels’ condition only, since – as discussed in the results section – there was no effect of the *vowel type* condition). As in the main experiment, the participants were native speakers of English with no previous exposure to a length-contrasting language, although they might have had some exposure to a different second language.

None of the participants reported any known history of speech or hearing problems.

3.1.4 Procedure

The experiment took place in a quiet room at the University of California, San Diego. First, the participants filled out a language background questionnaire. Then, they were told that they would listen to pairs of words in a language that they were not familiar with, and that their task was to decide whether they were hearing the same word repeated twice or two different words. They were given examples of contrasts that would make two words ‘different’ in this language. The examples were shown on a computer screen and an audio recording of each word pair was played to the participants. The table in (10) shows how the examples were displayed to the participants. The actual words they heard are shown in (11).

(10) *Instructions: examples of contrasts (as displayed)*

'different'	'same'
(different consonants) 'sh' – 's' 'h' – 'r'	'sh' – 'sh' 'r' – 'r'
(double or single consonants) 't' – 'tt' 'mm' – 'm'	't' – 't' 'mm' – 'mm'

(11) *Instructions: examples of contrasts (as auditorily presented)*

'different'	'same'
[ajfa:] ~ [ajsa:] [ħa:] ~ [ʕa:]	[ajfa:] ~ [ajʃa:] [ʕa:] ~ [ʕa:]
[ata:] ~ [atta:] [mmda:] ~ [mda:]	[ata:] ~ [ata:] [mmda:] ~ [mmda:]

These specific instructions were added after a pilot experiment, which showed (through post-experimental debriefing) that the participants were able to hear the difference between a geminate

and a singleton consonant, but did not generally consider this contrast sufficient to make a different word.

The participants were asked to sit in front of a computer, and listened to sounds over headphones. The computer screen displayed the question “Are these repetitions of the same word or two different words?” and two boxes with answers: “same word” and “different words.” Half of the participants saw the “same word” box on the left of the screen, and the “different words” box on the right. The other half saw the boxes in the opposite order. They were instructed to respond after hearing each pair by clicking on the appropriate box.

The experiment started with a practice session during which the participants listened to 16 ‘filler’ pairs (8 ‘different’ and 8 ‘same’ pairs), a fourth of which included a geminate/singleton contrast. No feedback was given during the practice session. The experiment followed immediately after the practice session. Each stimulus was played once without a replay option. The response to one stimulus triggered the presentation of the following stimulus with a delay of 500ms. There was a self-terminated break after each repetition of the experimental block.

The duration of the experiment was about 30 minutes (including the initial instructions and final debriefing).

3.2 Results

A-prime score was used as a measure of the participants’ capacity to perceive the geminate-singleton contrast. A-prime (Grier, 1971) is a nonparametric analog of d-prime (based on the principles of Signal Detection Theory; Macmillan and Creelman, 2005). Both A-prime and d-prime are measures of sensitivity to a given contrast, and are calculated by taking into account the proportion of Hits (correct ‘different’ responses; i.e. responding ‘different’ when the stimulus is ‘different’) and False Alarms (incorrect ‘different’ responses; i.e. responding ‘different’ when the stimulus is ‘same’).⁸ A-prime yields values between 0 and 1, where 0 means ‘no discriminability’ and 1 means ‘perfect discriminability.’⁹

A-prime scores were calculated for each participant and each context/voicing, and subsequently used for statistical analysis by performing a repeated measures ANOVA on the within-subjects factors *position* (‘medial’ or ‘initial’), *following segment* (‘+V’ or ‘+C’), *voicing* (‘voiced’ or ‘voiceless’), and the between-subjects factor *vowel type* (‘matching vowels,’ ‘non-matching vowels,’ ‘singleton vowels,’ or ‘geminate vowels’). Planned comparison tests were used to investigate the differences between the factor levels. The results are illustrated in Figure 2.

The mean A-prime score was 0.7. There was no significant effect of *vowel type* [$F < 1$], which means that there was no difference in performance in different vowel conditions. Thus, the results from all the ‘vowel type’ conditions were pooled together for further analysis.

The perception of the long vs. short consonant contrast was shaped by all the other factors. There was a significant main effect of *position* [$F(1,79)=28.4$; $p < .001$], *following segment* [$F(1,79)=60.7$; $p < .001$], and *voicing* [$F(1,79)=5.2$; $p < .05$]. Additionally, there were significant interactions between *position* and *following segment* [$F(1,79)=8.9$; $p < .01$], *position* and *voicing* [$F(1,79)=23.3$; $p < .001$], *following segment* and *voicing* [$F(1,79)=10.8$; $p < .01$], and a three-way interaction between *position*, *following segment* and *voicing* [$F(1,79)=18.4$; $p < .001$]. Planned

8 The formula used for calculating A-prime was the following: $A' = 0.5 + [(H-FA)(1+H-FA)]/[4H(1-FA)]$, where H = Hits, and FA = False Alarms (Grier, 1971, 425). In order to avoid infinite or undefined values, whenever H or FA were equal to 0 or 1, they were modified according to the following formulas: 0 was converted to $1/2N$, and 1 was converted to $1 - 1/2N$, where N = number of trials on which the proportion is based (Macmillan and Creelman, 2005).

9 It is also possible to obtain negative values when the rate of False Alarms is higher than the rate of Hits.

comparison tests revealed significant differences between all contexts [$p < .001$] except for ‘initial+V’ and ‘medial+C’ [$F < 1$]. The performance was better in the intervocalic environment (‘medial+V’; $A' = 0.82$) than in all other environments ($\bar{A}' = 0.67$). This effect also holds when calculated separately for [ss]/[s] ($A' = 0.84$ vs. 0.63) and [zz]/[z] ($\bar{A}' = 0.80$ vs. 0.71).

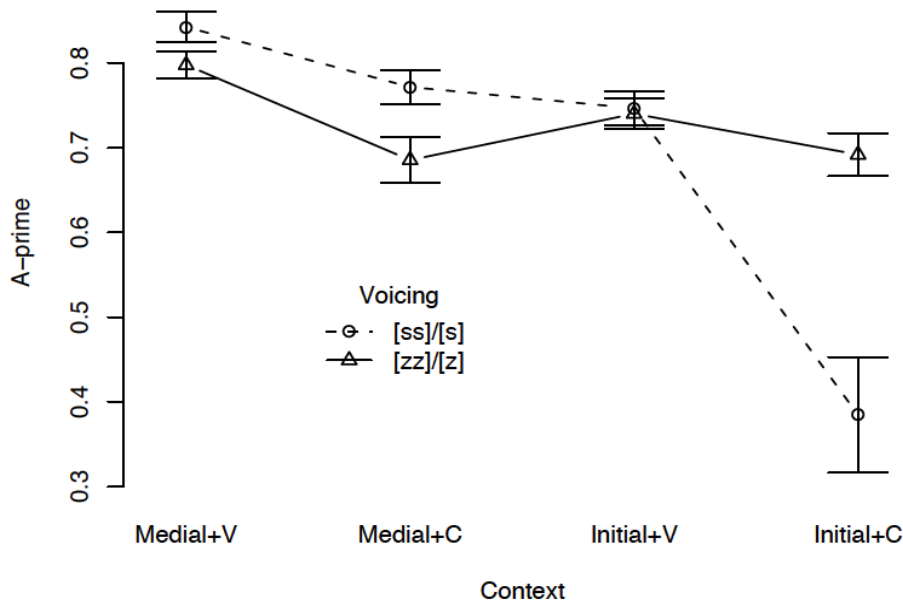

Figure 2: Experiment 2 – mean A-prime scores (error bars represent standard error of the mean).

Post-hoc analysis revealed a significant difference in *voicing* in the ‘initial+C’ context [Tukey, $p < .001$], but not in other contexts [Tukey, $p > .05$]. While for voiceless tokens discrimination of the contrast was worst in the ‘initial+C’ context ($A' = 0.38$), for voiced tokens the ‘initial+C’ context was not impaired with respect to the ‘medial+C’ context (both $A' = 0.69$).

The ‘500ms’ and ‘750ms’ versions of the experiment showed the same pattern as the original ‘250ms’ version, as illustrated in Figure 3, with identical mean A-prime score of 0.7 (the results for both ‘500ms’ and ‘750ms’ versions were not significantly different [$F < 1$], and therefore the data were pooled together). There were significant effects of *position* [$F(1,29) = 11.6$; $p < .01$], *following segment* [$F(1,29) = 42.7$; $p < .001$], but only a marginal effect of *voicing* [$F(1,29) = 4.1$; $p = .051$]. Additionally, there were significant interactions between *position* and *voicing* [$F(1,29) = 6.7$; $p < .05$], and *following segment* and *voicing* [$F(1,29) = 7.1$; $p < .05$]. Importantly, the performance was again better in the intervocalic environment (‘medial+V’) ($A' = 0.86$) than in all other environments ($A' = 0.65$). For the ‘initial+C’ context, there was again a difference between voiceless and voiced tokens: while the discrimination of voiceless tokens was significantly worse than in other contexts, the discrimination of voiced tokens was comparable to the ‘medial+C’ and the ‘initial+V’ contexts.

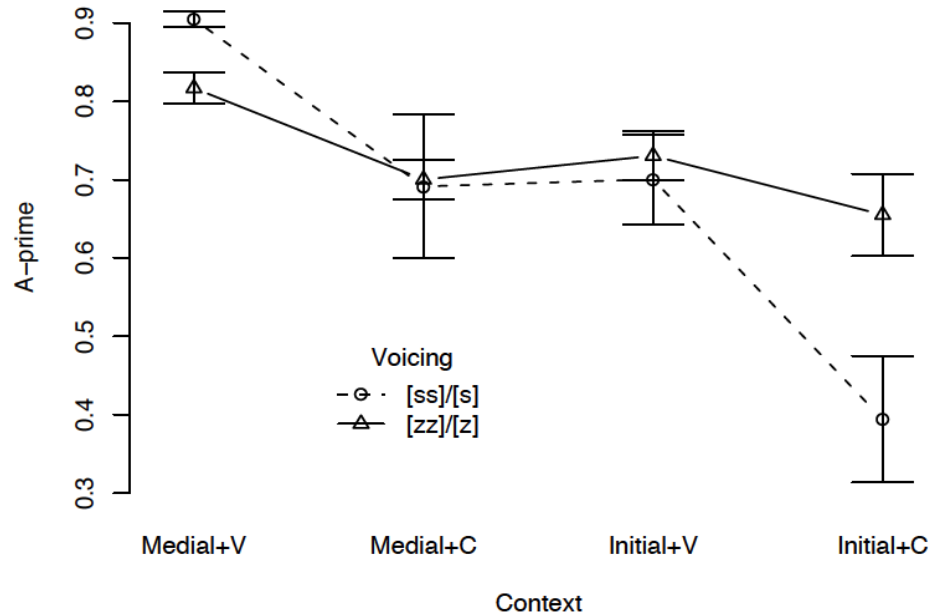

Figure 3: Experiment 2 – mean A-prime scores: ISI=500/750ms (error bars represent standard error of the mean).

A summary of all A-prime scores in both ISI versions of the experiment are provided in (12).

(12) Mean A-prime scores by context and voicing.

Context & voicing		Mean A-prime	
		ISI=250ms	ISI=500/750ms
Medial+V	voiceless: [assa:]/[asa:]	0.84	0.90
	voiced: [azza:]/[aza:]	0.80	0.82
Medial+C	voiceless: [assta:]/[asta:]	0.77	0.69
	voiced: [azzda:]/[azda:]	0.69	0.70
Initial+V	voiceless: [ssa:]/[sa:]	0.75	0.70
	voiced: [zza:]/[za:]	0.74	0.73
Initial+C	voiceless: [ssta:]/[sta:]	0.38	0.39
	voiced: [zzda:]/[zda:]	0.69	0.66

3.4 Discussion

The results of the experiment are consistent with the proposal that the context-dependent geminate preference scale is perceptually based. The perceptibility of the geminate-singleton

contrast *decreased* along the geminate preference scale: it was best in the intervocalic contexts, and worst in the non-vowel-adjacent contexts (or at least not better than in the single-vowel-adjacent contexts), as shown in (13).

(13) *Geminate preference scale and discriminability of the geminate-singleton contrasts (mean A-prime scores from both ISI versions of the experiment)*

intervocalic	<	single vowel-adjacent	<	non-vowel-adjacent
A ^ʹ =0.84		A ^ʹ =0.72		A ^ʹ =0.53

There was no effect of *vowel type*, which means that the participants performed the same way regardless of the vowel environment in which the fricatives were embedded. This result suggests that the participants did not pay attention to differences in vowel durations, and completed the task focusing on the duration of fricatives. Therefore, ‘vowel cues’ did not aid in the perception of the geminate-singleton contrast by non-native listeners.

Further support for the main hypothesis comes from the ‘500ms’ and ‘750ms’ versions of the experiment. The main pattern has been entirely replicated, indicating that changing the ISI does not alter the results of this particular experiment.

The main remaining question is what causes worse discriminability of non-intervocalic geminates and singletons. Geminate fricatives are longer in the dispreferred contexts, which at first might suggest that they should be perceived more easily. However, this is not the case. Increased duration of dispreferred geminates might be an attempt to compensate for their lesser perceptibility, but it is not enough to overcome the difference in perceptibility between the contexts. Instead, as already suggested in §2.3, the reason for worse perceptibility of non-intervocalic geminates might be the fact that the singletons are disproportionately longer in these dispreferred contexts, making the geminate/singleton duration ratios lower in non-intervocalic contexts than in the intervocalic ones (where lower ratio means a smaller difference in duration between a geminate and a singleton, which could in turn lead to their higher confusability). Geminate-singleton perceptibility indeed seems to roughly correlate with their duration ratios (as opposed to simple duration, which is negatively correlated with perceptibility): the higher the geminate/singleton ratio, the easier their discrimination. However, when examining the ratios in more detail, as illustrated in (14), it becomes clear that the ratios do not explain the full pattern of perceptibility. For example, the ‘initial+V voiced’ tokens have a high 2.2 ratio, but their discriminability is at 0.74. In contrast, the ‘medial+C voiceless’ tokens have a lower ratio of 2.0, but a much higher discriminability score of 0.87. Similarly, the ‘initial+C voiceless’ tokens have the lowest discriminability score of 0.39, even though their ratio is at 1.7, exactly the same as in two other contexts that are discriminated more easily.

All this suggests that the geminate/singleton duration ratio cannot be the only factor that determines their discriminability. Instead, there must be something intrinsically marked about the non-intervocalic contexts, again pointing to the proposed context-dependent geminate preference scale.

The final noteworthy point concerns the difference in perceptibility between voiceless and voiced tokens, which is especially striking in the least preferred context, ‘initial+C’: the geminate-singleton contrast was perceived more easily with voiced than with voiceless tokens. One might wonder if the perceptual difference in voicing for the ‘initial+C’ context is driven by the geminate/singleton duration ratios. However, as can be seen in (14), there are in fact no differences between voicing conditions in the ‘initial+C’ context, which suggests that another explanation must be sought. Voicing of a fricative might be considered advantageous in initial position from the point of view of perception. Voiced fricatives have higher noise amplitude than

(14) Mean A-prime scores (from both ISI versions of the experiment) and geminate/singleton duration ratios by context and voicing; the ordering is from highest to lowest A-prime.

Segment & context	Mean A-prime	Geminate/singleton duration ratio
Medial+V voiceless: [assa:]/[asa:]	0.87	2.0
Medial+V voiced: [azza:]/[aza:]	0.81	2.4
Initial+V voiced: [zza:]/[za:]	0.74	2.2
Medial+C voiceless: [assta:]/[asta:]	0.73	1.7
Initial+V voiceless: [ssa:]/[sa:]	0.73	1.9
Medial+C voiced: [azzda:]/[azda:]	0.70	1.9
Initial+C voiced: [zzda:]/[zda:]	0.68	1.7
Initial+C voiceless: [ssta:]/[sta:]	0.39	1.7

voiceless fricatives (e.g., Jongman, Wayland, & Wong 2000), and therefore their initial boundary might be easier to determine, while voiceless fricatives – especially in word initial position – could be more easily confused with surrounding noise. This might be related to the body of research which demonstrates that the perception of geminate-singleton contrast relies on perceiving the segments' boundaries in order to estimate their duration. For example, Kawahara (2007) has shown that in intervocalic contexts the geminate-singleton contrast is more perceptible for obstruent than for sonorant segments. Sonorants have higher intensities than obstruents, and therefore their boundaries in intervocalic contexts are less clearly marked due to their higher confusability with adjacent vowels. Length contrasts are more perceptible when surrounded by high jumps in loudness, or intensity, as is the case for intervocalic obstruents (see Kato, Tsuzaki, & Sagisaka 1997, Kawahara 2007). Therefore, the sequence 'silence-[zz]-stop closure' (as in [zzda:]) might allow for better boundary recognition than the sequence 'silence-[ss]-stop closure' (as in [ssta:]) due to higher jumps in amplitude for the voiced token. Note, furthermore, that the same would not necessarily be expected for the sequences 'silence-[zz]-vowel' (as in [zza:]) and 'silence-[ss]-vowel' (as in [ssa:]). Voiced fricatives are closer in amplitude to vowels than voiceless fricatives (Jongman et al. 2000), and therefore there is a bigger jump in intensity in [ss]+V sequences than in [zz]+V sequences, at least at the right edge of the fricatives.

Another explanation for the discrepancy between voiced and voiceless tokens in the 'initial+C' context can be related to the specific language background of the participants. All the participants were native speakers of English. Importantly, English allows initial 'st' clusters, but not 'zd' clusters. It is known that listeners tend to map non-native phoneme categories onto similar phoneme categories in their native language (e.g., Best, McRoberts, & Sithole 1988, Best 1994). The mapping does not occur for phoneme categories that are distant from all the categories available in the listener's native language. Therefore, it is possible that the participants of the experiments discussed in this paper mapped the geminate [ssta:] onto the sequence that is legal in English, namely [sta:]. This might have caused the difficulty in discriminating between the words [ssta:] and [sta:]. On the other hand, since [zzda:] and [zda:] are both impossible in English, they are not expected to be mapped onto a single sound sequence. This might have allowed the

participants to focus more on the difference between them.¹⁰

4. Experiment 3: Perception by Listeners Familiar with Length Contrasts

This section discusses the results of a perception experiment with English native speakers who have had previous exposure to another language with length contrasts.

4.1 Method

The method of the experiment was identical to experiment 2, as described in §3. The only difference concerned the language background questionnaire, which the participants filled out prior to beginning the experiment. In this study the questionnaire was more detailed, and included a short interview in order to gather specific information regarding the participants' proficiency and type of exposure to their second language (L2). The proficiency was measured as self-reported on the scale from 1 to 5. The type of exposure was coded as either through formal instruction at school or through native speaker family members.

4.1.1 Participants

There were 40 participants in this experiment (10 for each *vowel type* condition). They were all undergraduate students at the University of California, San Diego, and received extra credit for their participation.

The participants were native or near-native speakers of English with varying amount of previous exposure to a length-contrasting language: Armenian (1 participant), Egyptian Arabic (1), Farsi (1), German (2), Gujarati (1), Hebrew (3), Hindi/Urdu (5), Ilokano (1), Italian (5), Japanese (7), Jordanian Arabic (1), Korean (11), Modern Standard Arabic (2), Punjabi (2), Russian (2), Syrian Arabic (1), Tamil (1). Note that some of the participants were familiar with more than one of these languages, and they might also have had some exposure to a different language that does not use length contrastively (most commonly Spanish). 17 of the participants learned one or more of the listed languages through formal instruction at school (high school or college), while 23 of them were exposed to one or more of them since birth through native-speaker family members (in some cases in addition to learning one or more of them at school). Even though all of the latter 23 participants were exposed to the L2 since birth, most of them declared that English was their strongest language. 6 reported to have equal proficiency in both languages.

The L2s varied in the environments in which long consonants were allowed. For the purposes of this experiment, the participants were divided into two groups: (1) *only intervocalic*: L2 only allows intervocalic gemimates, and (2) *intervocalic + other*: L2 allows single-vowel-adjacent or non-vowel-adjacent gemimates, in addition to intervocalic ones, as shown in (15).

None of the participants reported any known history of speech or hearing problems.

4.3 Results

As in experiment 2, A-prime scores were calculated to measure participants' capacity to perceive the geminate-singleton contrast. The results were submitted to a repeated measures ANOVA with the within-subjects factors *position* ('medial' or 'initial'), *following segment* ('+V' or '+C'), *voicing* ('voiced' or 'voiceless'), and the between-subjects factor *vowel type* ('matching vowels,'

¹⁰ I would like to thank Sharon Rose for this suggestion.

(15) L2: context of geminates¹¹

Only intervocalic (15 participants)	Intervocalic + other (25 participants)				
	medial+C ¹²	medial+C ¹² & final	final & initial	final	all
Hebrew Ilokano Korean	Italian Japanese Tamil	Gujarati	Syrian Arabic	Egyptian Arabic Farsi German Hindi/Urdu Jordanian Arabic Modern St. Arabic Punjabi	Armenian Russian

‘non-matching vowels,’ ‘singleton vowels,’ or ‘geminate vowels’). Planned comparison tests were used to investigate the differences between the variable levels. The results are illustrated in Figure 4.

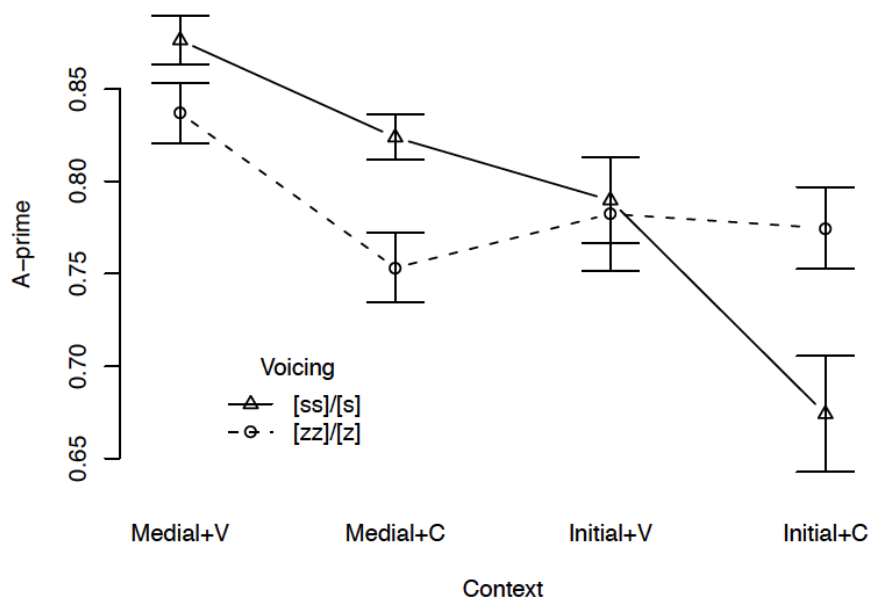

Figure 4: Experiment 3 – mean A-prime scores (error bars represent standard error of the mean).

The mean A-prime score was 0.79. As in experiment 2, there was no significant effect of *vowel*

11 Based on the data from Abu Abbas 2003, Ahn 1998, Arun 1961, Asher 1982, Bolozky 2004, Broselow 1976, Cardona 1965, Cowell 2005, Doctor 2006, Galvez & Rubino 2000, McCrary 2004, Nye 1954, Otaka 2009, Ryding 2005, Samuelian 1992, Schiffman 1999, Timberlake 2004, Vaux 1998, Wiese 1996.

12 The adjacent consonant could be on either side of the geminate.

type [$F < 1$]. Thus, the results from all the ‘vowel type’ conditions were pooled together for further analysis.

Similarly to experiment 2, there was a significant main effect of *position* [$F(1,39)=24.5$; $p < .001$] and *following segment* [$F(1,39)=19.3$; $p < .001$], but no effect of *voicing* [$F < 1$]. There was, however, a significant interaction between *position* and *voicing* [$F(1,39)=12.8$; $p < .001$], and a three-way interaction between *position*, *following segment* and *voicing* [$F(1,39)=5.9$; $p < .05$]. As in experiment 2, performance was better in the intervocalic environment (‘Medial+V’, $A=0.86$) than in all other environments ($A=0.77$). A summary of all A-prime scores are provided in (16).

(16) Mean A-prime scores by context and voicing.

Context & voicing		Mean A-prime
Medial+V	voiceless: [assa:]/[asa:]	0.88
	voiced: [azza:]/[aza:]	0.84
Medial+C	voiceless: [assta:]/[asta:]	0.82
	voiced: [azzda:]/[azda:]	0.75
Initial+V	voiceless: [ssa:]/[sa:]	0.79
	voiced: [zza:]/[za:]	0.78
Initial+C	voiceless: [sstta:]/[stta:]	0.67
	voiced: [zzda:]/[zda:]	0.77

In what follows, the results of comparisons between different groups of participants are discussed.

First, the participants of experiments 2 and 3 were compared. A repeated measures ANOVA was performed on the two groups with the within subjects factors *position* (‘medial’ or ‘initial’), *following segment* (‘+V’ or ‘+C’), *voicing* (‘voiced’ or ‘voiceless’), and the between-subjects factor *language background* (‘length-contrasting’ or ‘non-length-contrasting’). The results revealed a significant effect of *language background* [$F(1,936)=24.5$; $p < .001$] (together with other main effects). Participants familiar with a length-contrasting L2 performed better than participants with no previous exposure to any such language.

Second, within the experiment 3 participants, the ‘only intervocalic’ and ‘intervocalic+other’ groups were compared. There was a significant effect of *L2 context of geminates* ($F(1,296)=4.0$; $p < .05$). The listeners whose L2 only allowed intervocalic geminates performed worse ($A=0.77$) than the listeners whose L2 had geminates in other contexts, in addition to the intervocalic ones ($A=0.80$). These results, collapsed across voicing, are illustrated in Figure 5. A summary of all A-prime scores split by these two groups of participants are provided in (17).

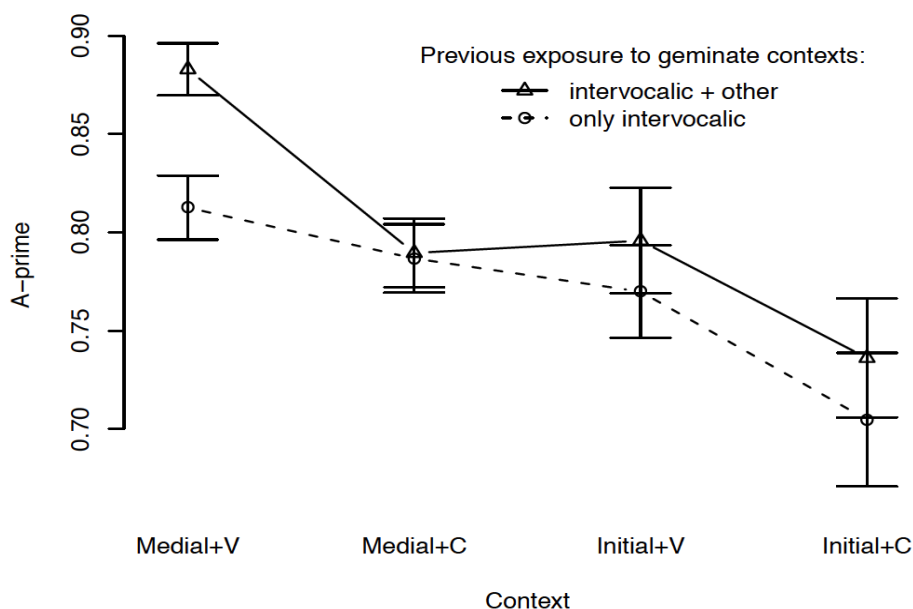

Figure 5: Experiment 3 – mean A-prime scores by L2 context of geminates (error bars represent standard error of the mean).

(17) Mean A-prime scores by context and voicing.

Context & voicing		Mean A-prime	
		'only intervocalic' group	'intervocalic+other' group
Medial+V	voiceless: [assa:]/[asa:]	0.84	0.90
	voiced: [azza:]/[aza:]	0.79	0.87
Medial+C	voiceless: [assta:]/[asta:]	0.84	0.82
	voiced: [azzda:]/[azda:]	0.74	0.76
Initial+V	voiceless: [ssa:]/[sa:]	0.75	0.81
	voiced: [zza:]/[za:]	0.79	0.78
Initial+C	voiceless: [sstta:]/[stta:]	0.63	0.70
	voiced: [zzzda:]/[zda:]	0.78	0.77

Finally, there was no effect of self-reported proficiency in L2, as determined by the lack of correlation between proficiency in the L2 (on a 1-5 scale) and A-prime [$t < 1$]. It also did not matter how the L2 was acquired: there was no difference between the participants learning their L2 at school and those acquiring it at home ($F < 1$).

4.4 Discussion

The results of experiment 3 showed the same exact pattern of responses as in experiment 2. Even though the participants in experiment 3 were, as predicted, overall better at discriminating the

geminate-singleton contrast than the participants in experiment 2, both groups showed perceptual advantage when the contrast was in the intervocalic contexts. This result suggests that while experience with a length contrast in one language helps with its perception in another language, it does not override relative perceptual difficulty with non-intervocalic geminates, which might arise from their intrinsic diminished perceptual saliency. Interestingly, participants whose L2 allowed geminates in more than one context performed overall better than participants whose L2 only had geminates in the intervocalic contexts, with the difference being especially striking *in the intervocalic contexts* ('medial+V') that all participants were familiar with, suggesting that experience with a given contrasts in more varied contexts improves overall ability to discriminate that contrast in *any* context.

Overall, these results are consistent with the proposal that the cross-linguistic context-dependent geminate preference scale has some basis in perception, with intervocalic geminates being the most perceptible, and non-vowel-adjacent geminates the least perceptible.

5. Concluding Remarks

The main finding reported in this paper is that perception of the geminate-singleton contrast by non-native listeners differs depending on the context (word position + adjacent segments). It is best in the intervocalic context (e.g., [assa:]), and worst in the non-vowel-adjacent context (e.g., [ssta:]). This result correlates with typological evidence, which indicates that geminates are most common intervocalically, and most rare when they are not adjacent to any vowels. It is taken as support for the hypothesis that the typologically-motivated geminate preference scale is at least partially based in perception.

However, the hypothesis has only been tested on alveolar fricatives. More needs to be learned about the behavior of other segments. Furthermore, only right-adjacent stops were used as adjacent consonants in the non-intervocalic contexts. Varying the adjacent consonant (e.g., obstruent vs. sonorant), as well as right vs. left-adjacency, could reveal more interesting properties of geminates.

Researching the differences between obstruent and sonorant geminates could prove particularly worthy. As already mentioned in §3.4, there is reason to believe that geminate sonorants might not follow the same pattern as geminate obstruents. Kawahara (2007) has shown that intervocalic obstruent geminates are more perceptible than sonorant geminates. If jumps of intensity at geminate boundaries are taken into account, then perhaps perceiving an obstruent-adjacent sonorant geminate (e.g., [allta]) should be easier than an intervocalic geminate (e.g., [alla]).

Finally, as investigated by Dmitrieva (2010), there are other factors – such as stress – that affect perceptibility of the geminate-singleton contrast. More research is needed to determine how these factors interact with word position and adjacent segments in shaping geminate perceptibility.

6. Acknowledgments

The author would like to thank undergraduate research assistants Rachel O'Sullivan and Christopher Gaudiot, as well as all the people who provided her with helpful feedback at different stages of this project: Amalia Arvaniti, Eric Bakovic, Klinton Bicknell, Lucien Carroll, Rebecca Colavin, Sarah Creel, Alex del Giudice, Christian DiCanio, Noah Girgis, Cynthia Kilpatrick, Roger Levy, Bob Port, Sharon Rose, Megha Sundara, as well as audiences at the Southern California Workshop on Phonetics/Phonology, the 83rd Annual Meeting of the LSA, and the 157th Meeting of the ASA. The author takes responsibility for all remaining errors.

7. Appendix: List of stimuli for experiments 2 & 3

Practice	
<i>'different'</i>	<i>'same'</i>
[axma:] ~ [aɤma:]	[aɤma:] ~ [aɤma:]
[ada:] ~ [ata:]	[ada:] ~ [ada:]
[ma:] ~ [na:]	[na:] ~ [na:]
[rba:] ~ [lba:]	[rba:] ~ [rba:]
[anna:] ~ [ana:]	[ana:] ~ [ana:]
[anta:] ~ [annta:]	[anta:] ~ [anta:]
[mma:] ~ [ma:]	[mma:] ~ [mma:]
[mmda:] ~ [mda:]	[mda:] ~ [mda:]

Test pairs	
<i>'different'</i>	<i>'same'</i>
[assa:] ~ [asa:]	[assa:] ~ [assa:]
[azza:] ~ [aza:]	[azza:] ~ [azza:]
[assta:] ~ [asta:]	[assta:] ~ [assta:]
[azzda:] ~ [azda:]	[azzda:] ~ [azzda:]
[ssa:] ~ [sa:]	[ssa:] ~ [ssa:]
[zza:] ~ [za:]	[zza:] ~ [zza:]
[ssta:] ~ [sta:]	[ssta:] ~ [ssta:]
[zzda:] ~ [zda:]	[zzda:] ~ [zzda:]
[asa:] ~ [assa:]	[asa:] ~ [asa:]
[aza:] ~ [azza:]	[aza:] ~ [aza:]
[asta:] ~ [assta:]	[asta:] ~ [asta:]
[azda:] ~ [azzda:]	[azda:] ~ [azda:]
[sa:] ~ [ssa:]	[sa:] ~ [sa:]
[za:] ~ [zza:]	[za:] ~ [za:]
[sta:] ~ [ssta:]	[sta:] ~ [sta:]
[zda:] ~ [zzda:]	[zda:] ~ [zda:]

Non-Intervocalic Geminates: Typology, Acoustics, Perceptibility

Filler pairs	
<i>'different'</i>	<i>'same'</i>
[aʃa:] ~ [aʒa:]	[aʃa:] ~ [aʃa:]
[ʁa:] ~ [xa:]	[xa:] ~ [xa:]
[arta:] ~ [arda:]	[arda:] ~ [arda:]
[ʕwa:] ~ [hwa:]	[hwa:] ~ [hwa:]
[qla:] ~ [kla:]	[qla:] ~ [qla:]
[anfa:] ~ [amfa:]	[amfa:] ~ [amfa:]
[aha:] ~ [axa:]	[aha:] ~ [aha:]
[la:] ~ [ra:]	[la:] ~ [la:]
[alla:] ~ [ala:]	[ala:] ~ [ala:]
[allba:] ~ [alba:]	[allba:] ~ [allba:]
[ama:] ~ [amma:]	[amma:] ~ [amma:]
[amda:] ~ [ammda:]	[amda:] ~ [amda:]
[la:] ~ [lla:]	[lla:] ~ [lla:]
[lba:] ~ [llba:]	[lba:] ~ [lba:]
[na:] ~ [nna:]	[na:] ~ [na:]
[nta:] ~ [nnta:]	[nnta:] ~ [nnta:]

8. References

- Abramson, Arthur S. 1986. 'The perception of word-initial consonant length: Pattani Malay', *Journal of the International Phonetics Association*, 26: 8-16.
- Abramson, Arthur S. 1992. 'Amplitude as a cue to word-initial consonant length: Pattani Malay', *Haskins Laboratories Status Report on Speech Research*, SR-109/110: 251-254.
- Abramson, Arthur S. 1999. 'Fundamental frequency as a cue to word-initial consonant length: Pattani Malay.' In *Proceedings of the 14th International Congress of Phonetic Sciences*. 591-594. Berkeley, CA: University of California, Berkeley.
- Abuabbas, Khaled H. 2003. *Topics in the phonology of Jordanian Arabic: an Optimality Theory perspective*. Doctoral dissertation. University of Kansas.
- Ahn, Sang-Cheol. 1998. *An introduction to Korean phonology*. Seoul: Hanshin Publishing Company.
- Arun, Vidya B. 1961. *A comparative phonology of Hindi and Panjabi*. Ludhiana: Panjabi Sahitya Akademi.
- Arvaniti, Amalia. 1999. 'Cypriot Greek and the phonetics and phonology of geminates.' In *Proceedings of the First International Conference of Modern Greek Dialects and Linguistic Theory*. 19-29. University of Patras.
- Arvaniti, Amalia. 2010. 'A (brief) overview of the phonetics and phonology of Cypriot Greek.' In *Proceedings of the conference on "the Greek language in Cyprus from antiquity to today"*, 23-24 May 2008. 107-124. Athens: University of Athens.
- Asher, R. E. 1982. *Tamil*. Amsterdam: North-Holland Publishing Company.
- Baum, Shari R. and Sheila E. Blumstein. 1987. 'Preliminary observations on the use of duration as a cue to syllable-initial fricative consonant voicing in English', *Journal of the Acoustical Society of America*, 82(3): 1073-1077.
- Benus, Stefan, Iris Smorodinsky, and Adamantios Gafos. 2003. 'Gestural coordination and the distribution of English 'geminates'.' In *Proceedings of the 27th annual penn linguistics colloquium*. 33-46. Philadelphia, PA: University of Pennsylvania.
- Best, Catherine T. 1994. 'The emergence of native-language phonological influence in infants: A perceptual assimilation model.' In J. Goodman & H. Nusbaum (eds.), *The development of speech perception: The transition from speech sounds to spoken words*. 167-224). Cambridge: MIT Press.
- Best, Catherine T., Gerald W. McRoberts, and Nomathemba M. Sithole. 1988. 'Examination of perceptual reorganization for nonnative speech contrasts: Zulu click discrimination by English-speaking adults and infants', *Journal of Experimental Psychology: Human Perception and Performance*, 14: 345-360.
- Bethin, Christina Y. 1992. *Polish syllables. The role of prosody in phonology and morphology*. Columbus, Ohio: Slavica Publishers.
- Blust, Robert. 1995. *Austronesian Comparative Dictionary*. Honolulu: University of Hawaii at Manoa.
- Blust, Robert. 2001. 'Language, dialect, and riotous sound change: the case of Sa'ban.' In Graham Thurgood (ed.), *Papers from the 9th Annual Meeting of the Southeast Asian Linguistics Society, 1999*. 249-359. Tempe: Arizona State University Monograph Series Press.
- Blust, Robert. 2007. 'Disyllabic attractors and anti-antigemination in Austronesian sound change', *Phonology*, 24: 1-36.
- Boersma, Paul and David Weenink. 2008. *Praat: doing phonetics by computer (Version 5.0.22)*. [Computer program]. Retrieved from <http://www.praat.org/>.
- Bolozky, Shmuel. 2004. 'Surface geminates (dages forte) in Israeli Hebrew'. In L. H. Ehrlich, S. Bolozky, R. A. Rothstein, M. Schwartz, J. R. Berkovitz, & J. E. Young (eds.), *Textures and meanings: thirty years of Judaic studies at the University of Massachusetts Amherst*. 342-348. Amherst: Department of Judaic and Near Eastern Studies, University of Massachusetts Amherst.
- Bothorel, André. 1999. 'La gémination consonantique dans un parler Breton (Argol).' In A. Rigault & R. Charbonneau (eds.), *Proceedings of the Seventh International Congress of Phonetic Sciences*. 659-665. The Hague: Mouton.
- Bowden, John. 2001. *Taba: description of a South Halmahera language*. Canberra: Pacific Linguistics.
- Broselow, Ellen. 1976. *The phonology of Egyptian Arabic*. Doctoral dissertation. University of Massachusetts.
- Cardona, George. 1965. *A Gujarati reference grammar*. Philadelphia: The University of Pennsylvania Press.
- Clements, George. 1990. 'The role of the sonority cycle in core syllabification.' In J. Kingston & M. E. Beckman (eds.), *Papers in laboratory phonology I: between the grammar and physics of speech*. 282-333. Cambridge: Cambridge University Press.
- Côté, Marie-Hélène. 2000. *Consonant cluster phonotactics: A perception-based approach*. Doctoral dissertation. Massachusetts Institute of Technology.
- Cowell, Mark W. 2005. *A reference grammar of Syrian Arabic*. Washington, D.C.: Georgetown University Press.
- Crothers, John H., James P. Lorentz, Donald Sherman, and Marilyn Vihman. 1979. *Handbook of phonological data from a sample of the world's languages: A report of the Stanford Phonology Archive*. Stanford, CA: Stanford University, Department of Linguistics.
- Davis, Stuart. 1999. 'On the representation of initial geminates', *Phonology*, 16: 93-104.
- de Manrique, Ana María Borzone and María Ignacia Massone. 1981. 'Acoustic analysis and perception of Spanish fricative consonants' *Journal of the Acoustical Society of America*, 69: 1145-1153.
- Dell, François and Mohamed Elmedlaoui. 1985. 'Syllabic consonants and syllabification in Imdlawn Tashlhiyt Berber', *Journal*

Non-Intervocalic Gemimates: Typology, Acoustics, Perceptibility

- of African Languages and Linguistics*, 7: 105–130.
- Dell, François and Mohamed Elmedlaoui. 1988. 'Syllabic consonants in Berber: some new evidence', *Journal of African Languages and Linguistics*, 10: 1-17.
- Dietrich, Christiane, Daniel Swingley, and Janet F. Werker. 2007. 'Native language governs interpretation of salient speech sound differences at 18 months', *Proceedings of the National Academy of Sciences*, 104: 16027-16031.
- Dmitrieva, Olga. 2010. 'Perception of consonant length is universal: Evidence from American and Russian listeners.' Poster presented at the 84th Annual Meeting of the Linguistic Society of America. Baltimore, MD. (<http://www.stanford.edu/~dmitro/LSA%202010%20poster.pdf>)
- Doctor, Raimond. 2004. *A grammar of Gujarati*. München: Lincom Europa.
- Fougeron, Cécile and Patricia A. Keating. 1997. 'Articulatory strengthening at edges of prosodic domains', *Phonology*, 101(6): 3728-3740.
- Galvez-Rubino, Carl R. 2000. *Ilocano dictionary and grammar: Ilocano-English, English-Ilocano*. Honolulu: University of Hawaii Press.
- Goodman, Beverley. 1995. *Features in Ponapean phonology*. Doctoral dissertation. Cornell University.
- Grier, J. Brown. 1971. 'Nonparametric indexes for sensitivity and bias', *Psychological Bulletin*, 75(6): 424-429.
- Haggard, Mark. 1973. 'Abbreviation of consonants in English pre- and post-vocalic clusters', *Journal of Phonetics*, 1: 9-24.
- Ham, William H. 2001. *Phonetic and phonological aspects of geminate timing*. New York: Routledge.
- Harrikari, Heli. 1999. 'Epenthesis, geminates, and the OCP in Finnish', *Nordic Journal of Linguistics*, 22: 3-26.
- Hayes, Bruce. 1986. 'Inalterability in CV phonology', *Language*, 62: 321-351.
- Hayes, Bruce. 1989. 'Compensatory lengthening in moraic phonology', *Linguistic Inquiry*, 20: 253-306.
- Heath, Jeffrey. 1987. *Ablaut and ambiguity. Phonology of a Moroccan Arabic dialect*. Albany: State University of New York Press.
- Hooper, Joan B. 1976. *An introduction to natural generative phonology*. New York: Academic Press.
- Hume, Elizabeth. 2001. 'Metathesis: formal and functional considerations.' In E. Hume, N. Smith, & J. van de Weijer (eds.), *Surface syllable structure and segment sequencing*. 1-25). Leiden: HIL.
- Hume, Elizabeth, Jennifer Muller, and Aone van Engelenhoven. 1997. 'Non-moraic geminates in Leti', *Phonology*, 14: 371-402.
- Hyman, Larry. 1985. *A theory of phonological weight*. Dordrecht: Foris.
- Jongman, Allard, Ratee Wayland, and Serena Wong. 2000. 'Acoustic characteristics of English fricatives', *Journal of the Acoustical Society of America*, 108(3): 1252-1263.
- Kato, Hiroaki, Minoru Tsuzaki, and Yoshinori Sagisaka. 1997. 'Acceptability for temporal modification of consecutive segments in isolated words', *Journal of the Acoustical Society of America*, 101(4): 2311-2322.
- Kawahara, Shigeto. 2005. 'Voicing and geminacy in Japanese: an acoustic and perceptual study', *University of Massachusetts Occasional Papers in Linguistics*, 31: 87-120.
- Kawahara, Shigeto. 2007. 'Sonorancy and geminacy.' In *University of Massachusetts Occasional Papers in Linguistics 32: Papers in Optimality III*. 145-186. Amherst: GLSA.
- Kenstowicz, Michael. 1982. 'Gemination and spirantization in Tigrinya', *Studies in the Linguistic Science*, 12(1): 103-122.
- Kiparsky, Paul. 1979. 'Metrical structure assignment is cyclic', *Linguistic Inquiry*, 10: 421-441.
- Klatt, Dennis. 1973. 'Durational characteristics of pre-stressed word initial consonant clusters in English', *MIT Research Laboratory of Electronics, Quarterly Progress Report*, 108: 253-260.
- Ladefoged, Peter and Ian Maddieson. 1996. *The sounds of the world's languages*. Oxford, UK; Cambridge, MA: Blackwell.
- Lahiri, Aditi and Jorge Hankamer. 1988. 'The timing of geminate consonants', *Journal of Phonetics*, 16: 327–338.
- Leslau, Wolf. 1995. *Reference grammar of Amharic*. Wiesbaden: Harrassowitz.
- Levin, Juliette. 1985. *A metrical theory of syllabicity*. Doctoral dissertation. Massachusetts Institute of Technology.
- Loporcaro, Michelle. 1996. 'On the analysis of geminates in Standard Italian and Italian dialects.' In B. Hurch & R. A. Rhodes (eds.), *Natural phonology: the state of the art*. 153-188. Berlin/New York: Mouton de Gruyter.
- Macmillan, Neil A. and C. Douglas Creelman. 2005. *Detection theory: a user's guide (2nd ed.)*. Mahwah, NJ: Lawrence Erlbaum Associates.
- McCrary, Kristie. 2002. 'Syllable structure vs. segmental phonotactics: Geminates and clusters in Italian revisited.' In *Swot 2002: Proceedings of the Texas Linguistic Society*. (http://uts.cc.utexas.edu/tls/2002tls/TLS_2002_Proceedings.html)
- McCrary, Kristie. 2004. *Reassessing the role of the syllable in Italian phonology: an experimental study of consonant cluster syllabification, definite article allomorphy and segment duration*. Doctoral dissertation. University of California, Los Angeles.
- Mugitani, Ryoko, Ferran Pons, Laurel Fais, Janet F. Werker, and Shigeaki Amano. 2008. 'Perception of vowel length by Japanese- and English-learning infants', *Developmental Psychology*, 45(1): 236-247.
- Muller, Jennifer. 1999. 'A unified mora account of Chuukese', In *Proceedings of the West Coast Conference on Formal Linguistics 18*. 393-405). Tucson, AZ: University of Arizona.
- Muller, Jennifer. 2001. *The phonology and phonetics of word-initial geminates*. Doctoral dissertation. Ohio State University.
- Narayan, Chandan. 2006. *Acoustic-perceptual salience and developmental speech perception*. Doctoral dissertation. University of Michigan.

- Nye, Gertrude E. 1954. *The phonemes and morphemes of Modern Persian: a descriptive study*. Doctoral dissertation. University of Michigan.
- Otaka, Hiromi. 2009. *Phonetics and phonology of moras, feet, and geminate consonants in Japanese*. Lanham: University Press of America.
- Pajak, Božena. 2009. 'Contextual constraints on geminates: the case of Polish.' In *Proceedings of BLS 35*. 269-280. Berkeley, CA: University of California, Berkeley.
- Payne, Elinor. 2000. *Consonant gemination in Italian: phonetic evidence for a fortition continuum*. Doctoral dissertation. University of Cambridge.
- Payne, Elinor. 2005. 'Phonetic variation in Italian consonant germination', *Journal of the International Phonetic Association*, 35: 153-189.
- Payne, Elinor and Eftychia Eftychiou. 2006. 'Prosodic shaping of consonant gemination in Cypriot Greek', *Phonetica*, 63: 175-198.
- Ridouane, Rachid. 2008. 'Syllables without vowels: phonetic and phonological evidence from Tashlhiyt Berber', *Phonology*, 25: 321-359.
- Rubach, Jerzy. 1986. 'Does the Obligatory Contour Principle operate in Polish?', *Studies in the Linguistic Sciences*, 16(1): 133-147.
- Ryding, Karin C. 2005. *A reference grammar of Modern Standard Arabic*. Cambridge: Cambridge University Press.
- Salim, Issam M. Abu. 1980. 'Epenthesis and geminate consonants in Palestinian Arabic', *Studies in the Linguistic Sciences*, 10: 1-11.
- Samuelian, Thomas J. 1992. *Armenian dictionary in transliteration: Western pronunciation*. New York: Hippocrene Books.
- Schiffman, Harold F. 1999. *A reference grammar of spoken Tamil*. Cambridge: Cambridge University Press.
- Selkirk, Elizabeth. 1984. 'On the major class features and syllable theory.' In M. Aronoff & R. Oehrle (eds.), *Language sound structure*. 107-136. Cambridge: MIT Press.
- Selkirk, Elizabeth. 1991. 'On the inalterability of geminates.' In P. M. Bertinetto, M. Kenstowicz, & M. Loporcaro (eds.), *Certamen Phonologicum ii: Papers from the Second Annual Cortona Phonology Meeting*. 187-210. Turin: Rosenberg & Sellier.
- Smeets, Riëks. 1984. *Studies in West Circassian phonology and morphology*. Leiden: The Hakuchi Press.
- Spaelti, Philip. 1994. 'Weak edges and final geminates in Swiss German.' In M. Gonzalez (ed.), *Proceedings of NELS 24*. Amherst, MA: University of Massachusetts. [ROA-18].
- Steriade, Donca. 1982. *Greek prosodies and the nature of syllabification*. Doctoral dissertation. Massachusetts Institute of Technology.
- Steriade, Donca. 2001. 'Directional asymmetries in place assimilation: a perceptual account'. In E. Hume & K. Johnson (eds.), *Perception in phonology*. 219-250. San Diego, CA: Academic Press.
- Steriade, Donca. 2008. 'The phonology of perceptibility effects: The P-map and its consequences for constraint organization.' In K. Hanson & S. Inkelas (eds.), *The nature of the word: Studies in honor of Paul Kiparsky*. 151-180. Cambridge, MA: MIT Press.
- Thurgood, Graham. 1993. 'Geminates: a cross-linguistic examination'. In J. A. Nevis, G. McMenamin, & G. Thurgood (eds.), *Papers in honor of Frederick H. Bregelman on the occasion of the 25th anniversary of the Department of Linguistics, CSU Fresno*. 129-139. Fresno, CA: Department of Linguistics, California State University, Fresno.
- Timberlake, Alan. 2004. *A reference grammar of Russian*. Cambridge: Cambridge University Press.
- Topintzi, Nina. 2006. *Geminates and syllabification in Pattani Malay and Marshallese*. Handout from the 2nd Conference on Austronesian Languages and Linguistics. St Catherine's College, Oxford, UK.
- Topintzi, Nina. 2008. 'On the existence of moraic onset geminates', *Natural Language and Linguistic Theory*, 26(1): 147-184.
- Tranel, Bernard. 1991. 'CVC light syllables, geminates and Moraic Theory', *Phonology*, 8: 113-136.
- Vaux, Bert. 1998. *The phonology of Armenian*. Oxford: Clarendon Press.
- Werker, J. F. & Logan, J. S. (1985). Cross-language evidence for three factors in speech perception. *Perception and Psychophysics*, 37, 35-44.
- Werker, Janet F. and Richard C. Tees. 1984. 'Phonemic and phonetic factors in adult cross-language speech perception', *Journal of the Acoustical Society of America*, 75: 1866-1878.
- Wiese, Richard. 1996. *The phonology of German*. Oxford: Clarendon Press.
- Zec, Draga. 1995. 'Sonority constraints on syllable structure', *Phonology*, 12: 85-129.

Božena Pajak
 Department of Linguistics
 University of California, San Diego
 bpajak@ucsd.edu