

Lawrence Berkeley National Laboratory

LBL Publications

Title

Induction accelerator technology choices for the integrated beam experiment (IBX)

Permalink

<https://escholarship.org/uc/item/2bm88648>

Authors

Leitner, M.A.

Celata, C.M.

Lee, E.P.

et al.

Publication Date

2002-11-21

INDUCTION ACCELERATOR TECHNOLOGY CHOICES FOR THE INTEGRATED BEAM EXPERIMENT (IBX) *

M.A. Leitner⁽¹⁾, C.M. Celata, E.P. Lee, B.G. Logan, G. Sabbi, W.L. Waldron
Ernest Orlando Lawrence Berkeley National Laboratory
1 Cyclotron Road, Berkeley, CA 94720, USA

J.J. Barnard
Lawrence Livermore National Laboratory
7000 East Avenue, Livermore, CA 94550, USA

ABSTRACT

Over the next three years the research program of the Heavy Ion Fusion Virtual National Laboratory (HIF-VNL), a collaboration among LBNL, LLNL, and PPPL, is focused on separate scientific experiments in the injection, transport and focusing of intense heavy ion beams at currents from 100 mA to 1 A. As a next major step in the HIF-VNL program, we aim for a complete "source-to-target" experiment, the Integrated Beam Experiment (IBX). By combining the experience gained in the current separate beam experiments IBX would allow the integrated scientific study of the evolution of a single heavy ion beam at high current (~1 A) through all sections of a possible heavy ion fusion accelerator: the injection, acceleration, compression, and beam focusing.

This paper describes the main parameters and technology choices of the planned IBX experiment. IBX will accelerate singly charged potassium or argon ion beams up to 10 MeV final energy and a longitudinal beam compression ratio of 10, resulting in a beam current at target of more than 10 Amperes. Different accelerator cell design options are described in detail: Induction cores incorporating either room temperature pulsed focusing-magnets or superconducting magnets.

1. INTRODUCTION

To validate the attractiveness of a heavy ion accelerator as a candidate for an inertial fusion energy driver the U.S. Heavy Ion Fusion program is supporting several key experimental programs. Over the next few years the Heavy Ion Fusion Virtual National Laboratory (HIF-VNL) will be completing a set of small proof-of-principle experiments addressing scientific questions related to heavy ion fusion drivers [1]. The goal of these experiments is to demonstrate the feasibility of key driver beam manipulations, which can be investigated in separate experiments at a small scale.

*This work was performed under the auspices of the U.S. Department of Energy by the University of California, Lawrence Berkeley National Laboratory under contract number DE-AC03-76SF00098, Lawrence Livermore National Laboratory under contract number W-7405-Eng-48, Massachusetts Institute of Technology under contract number DE-FC02-93-ER54186, and by the Princeton Plasma Physics Laboratory under contract number DE-AC02-76CH03073.

(1) Tel: (510) 486 4090, MLeitner@lbl.gov

As a next step, the HIF-VNL proposes a fully integrated beam physics experiment. This intermediate-scale experiment, the Integrated Beam Experiment (IBX), will allow important access to significant areas of heavy ion fusion physics. It will constitute an integrated test of much of the physics of a driver, and produce a base of data and experience thereby laying the groundwork for a larger, proof-of-performance experiment, the Integrated Research Experiment (IRE). Therefore, the Integrated Beam Experiment (IBX) will constitute the necessary bridging step between the currently performed small scale experiments used to demonstrate feasibility and physics, and a later larger Integrated Research Experiment (IRE), a proof-of-performance experiment which would demonstrate all the physics and technology necessary to a driver.

2. IBX COMPONENTS AND SPECIFICATIONS

IBX will integrate injection, acceleration, drift compression, final focus and chamber transport with plasma neutralization into a single experiment to allow testing of source-to-target integrated beam models. The IBX project is currently in a

DRAFT

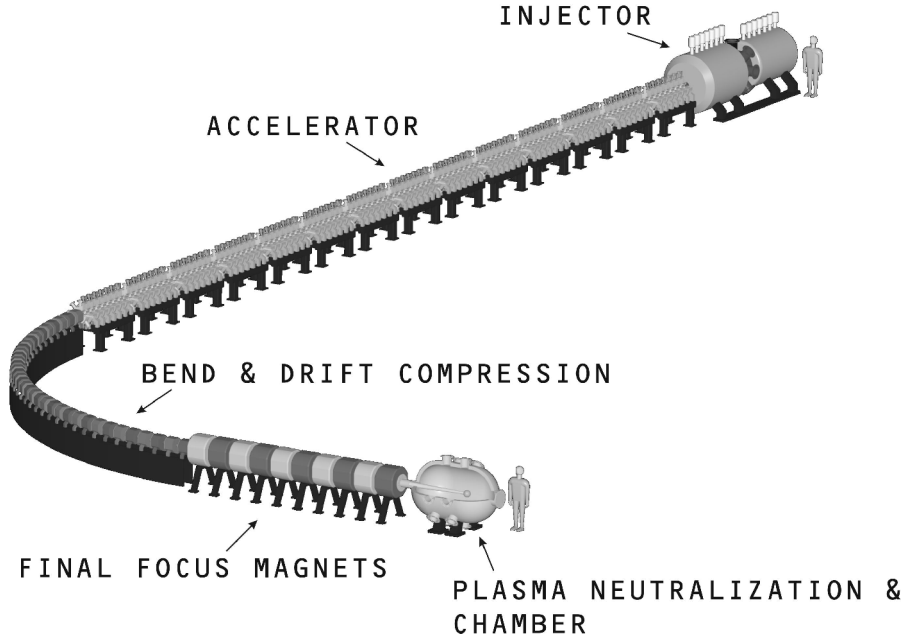

Fig. 1: Schematic layout of the Integrated Beam Experiment (IBX).

pre-conceptual design stage. A range for IBX main performance parameters as required by the planned experimental program, which will be described in the next section, is listed in the following table:

INJECTOR	
Ion:	K^+ or Ar^+
Current:	$0.2 - 0.7 A$
Energy:	$1.0 - 1.7 MeV$
Pulse Length:	$0.25 - 3 s$
ACCELERATOR:	
Number of Half Lattice Periods:	$\sim 40 - 100$
Half Lattice Period Length:	$30 cm$
Final Energy:	$5 - 10 MeV$
BEND & DRIFT COMPRESSION:	
Number of Half Lattice Periods:	~ 30
Compression Ratio:	10
FINAL FOCUS & PLASMA NEUTRALIZATION:	
Number of Half Lattice Periods:	~ 10
Final Beam Pulse Length:	$\sim 25 ns$
Final Perveance:	$\sim 1 \cdot 10^3$
Final Space Charge Density:	$0.7 - 2 C/m$
Final Current:	$> 10 A$

Figure 1 shows the mechanical layout of a 10 MeV IBX version. To advance the integrated heavy-ion beam physics program in a time- and cost-effective manner IBX will rely mainly on the use of existing technology, in particular

induction core- and superconducting magnet-designs developed in the heavy ion fusion program.

3. IBX SCIENTIFIC GOALS

A rich, driver-relevant scientific agenda can be explored by an Integrated Beam Experiment. Because of its sufficient number of lattice periods, and because it includes source-to-target beam propagation with all necessary beam manipulations, such an experiment will open up a field for investigating and exploring heavy ion fusion concepts that - up to now - have only been accessible through simulations, but could not be investigated in prior experiments. The major elements of the scientific goals for IBX are:

- The longitudinal properties of a driver-scale beam under induction acceleration, its profile and the manipulation of that profile, and the resultant emittance changes, will be studied for the first time.
- Limits of acceleration and longitudinal beam physics can be examined for the first time.
- In particular, IBX will be the first experiment to allow exploration of all post-accelerator manipulations of the beam found in a future driver - drift compression, final focus, and chamber transport.
- Electron dynamics with acceleration will also be addressed, with the opportunity for the first time to see the effect on beam transport.
- The final focus spot size on target depends on the accumulated beam phase-space changes through each region along the accelerator system. The crucial integration role of the

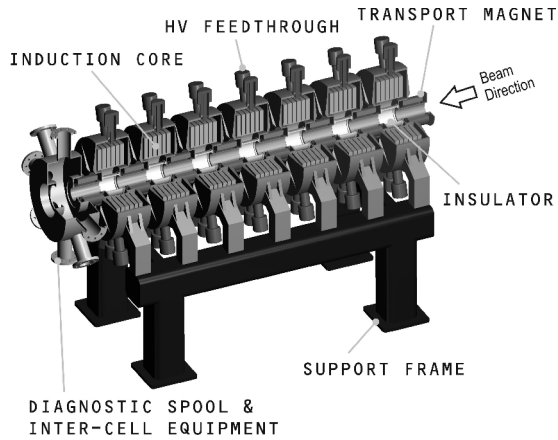

Fig. 2: Components of an IBX acceleration module. A half lattice period consists of a quadrupole magnet and an induction acceleration gap. Every several half lattice periods an induction cell is supplanted by a vacuum spool for diagnostics, pumping and auxiliary access.

IBX will be to test the ability to achieve a high beam brightness (focusability) from source to target, and the ability to predict the final focal spot size.

- A key strategic goal in the HIF-VNL theory/simulation program is an integrated and detailed source-to-target simulation capability. The IBX will provide a well-diagnosed experiment to benchmark integrated beam dynamics simulation codes for a single beam through the injection, acceleration, longitudinal drift compression, and final focus, with sufficient beam current to include important gas/electron interactions.
- The Integrated Beam Experiment will give physics data, which are needed to optimize design quantities such as the accelerator aperture, pulse length, and final focus and compression strategies of an IRE.

This integrated source-to-target experiment will have a final kinetic energy up to 10 MeV. The charge-per-unit length of 1-2 C/m will approach driver range of ~ 10 C/m in order to produce the space charge potential necessary for electron dynamics and final transport neutralization studies. The final perveance (measure of the ratio of space charge potential energy to kinetic energy) of the beam after longitudinal compression of a factor of 10 will be $\sim 10^{-3}$. The option of such an aggressive beam compression will enable exploration of a wide range of final focus transport and final compression alternatives including the opportunity to employ a variety of schemes to correct geometric and chromatic beam aberrations.

4. IBX TECHNOLOGY CHOICES

The IBX accelerator is a current-amplifying heavy ion induction linac with a focusing/defocusing magnetic

quadruple transport lattice. The accelerator is built from individual modules as indicated in figure 1. Figure 2 displays schematically the main components of such an IBX accelerator module. A broad range of design alternatives had been examined during IBX pre-conceptual costing studies. This paper concentrates on technology choices and development needs for the beam transport magnets and acceleration induction cores. Required R&D effort for IBX in the area of short-pulse ion beam injectors, high-gradient insulators, and high-power pulsers are not further described.

4.1 Transport Magnets

IBX has the choice of using either pulsed room-temperature (RT) or steady-state superconducting (SC) quadrupoles for the ion beam transport magnets. Ultimately, for an IRE and HIF driver, superconducting magnets will have an advantage over RT magnets in terms of field quality, efficiency, and reliability. SC magnets are also significantly more cost effective in large quantity. But up to today mainly RT pulsed magnets were used for HIF-VNL experiments because of their significantly lower cost if used in small quantity. Figure 3 shows a cross-sectional view of a RT and a SC version of IBX acceleration cells. IBX will need approximately 100 focusing magnets, which is slightly below the turning point where SC magnets become more cost effective. For this reason present effort is focused on a tradeoff study comparing both technologies.

A pulsed RT quadrupole magnet [2] is in essence a high voltage, low inductance, current dominated magnet design with one or two coil layers around a thin-walled beam tube. The epoxy potted magnet coil is assembled inside a laminated iron core which provides flux return but does not shape the magnetic field inside the bore. Dependant on the pulse repetition rate the magnets are either air-cooled or edge water-cooled. As an example, figure 4 shows the components of a (large-bore) pulsed quadrupole magnet used in the final

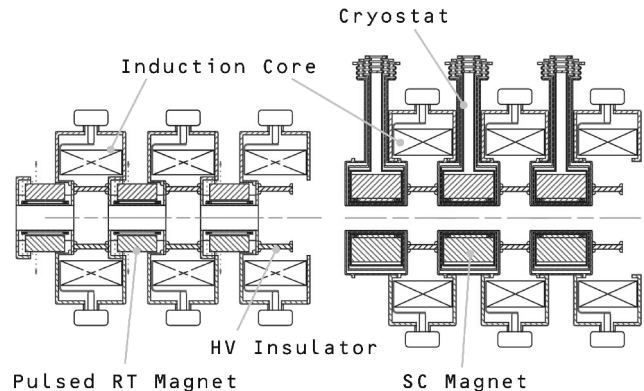

Fig. 3: Comparison between a room-temperature (RT) version and a superconducting version (SC) of IBX.

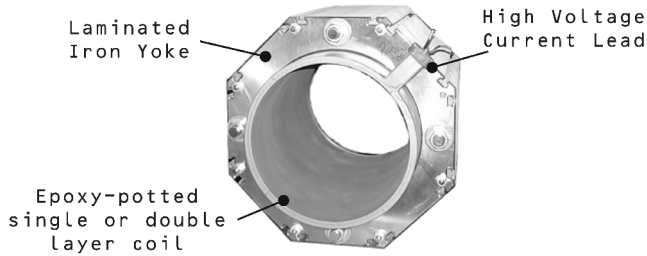

Fig. 4: Pulsed, room temperature magnet design.

focus experiment NTX [1] at LBNL.

The minimum required field gradient for the IBX transport quadrupoles is 40 T/m. Based on a conceptual RT pulsed magnet design for IBX a maximum field gradient of 70 T/m at 3.5 kV lead voltage and 6500 A current could be achieved. (As a comparison, the maximum field gradient achieved up to today in an existing pulsed magnet built for an IRE prototype array [2] is 40T/m at 4400 A and 3.2 kV.) The intrinsic disadvantage of these magnets is related to the pulsed nature of the magnetic field, which makes measurements inside the magnet bore difficult and complicates significantly the design of the beam tube and flanges because of eddy current effects. Long-term reliability is an issue related to the pulsed strong magnetic forces, as well as the high voltage and high current required for operation.

Because of the attractiveness of SC technology in the long run the HIF-VNL had initiated a SC magnet development program together with MIT Plasma Science and Fusion Center and Advanced Magnet Lab (AML). In current baseline HIF driver designs, SC magnets have to focus tens of hundreds tightly packed beams accelerated in parallel, which form a rectangular array. Comparison [3] of different approaches shows that flat pancake windings are advantageous compared to shell-type coils. Therefore, Figure 5 shows a 3x3 fragment of such a focusing magnet array with rectangular racetrack windings.

To demonstrate the feasibility of the design principles for such a magnet system, several full-scale, single-bore prototype cells (as shown in fig. 5) have been designed, built, and tested [4]. Present effort centers on the development of a cryostat housing two superconducting quadrupoles. Such a single-beam focusing unit is currently under construction at MIT using two existing prototype quadrupoles. From the beginning, the prototype quadrupole magnets have been designed to allow integration into the existing High Current Experiment (HCX, [1]) at LBNL for testing. Due to the low beam energy (up to 1.7 MeV), the HCX lattice has a short period of 45 cm. In the hard-edge model, a nominal quadrupole gradient of 84.2 T/m over a magnetic length of 10.1 cm is required. (For detailed magnet data see [4].)

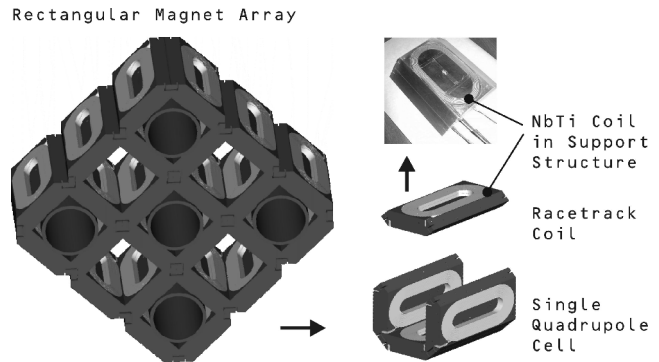

Fig. 5: Fragment of a focusing magnet array with rectangular racetrack windings. Only one individual quadrupole cell is needed for the single beam experiment IBX.

Additional quadrupoles with further optimized coil shape are currently in fabrication and are expected to reach magnetic field gradients significantly in excess of 100 T/m. These quadrupoles could be used as prototype magnets for IBX. Using highest possible field gradients for the quadrupole magnets in IBX allows to shorten the physical magnet length while maintaining the required integrated field gradient. In addition, short magnets allow larger gaps for induction cells and diagnostics devices.

The use of superconducting magnets in IBX has two major advantages over pulsed RT magnets: First, they are steady-state, eliminating eddy current problems. Secondly, the magnet cryostats can provide a cold (50-77 K) pumping surface in the beam tube. Therefore, IBX could simulate exactly the same vacuum environment seen by the heavy ion beam in a HIF driver. This allows to explore limitations associated with magnetic focusing, in particular the onset of instabilities due to electrons trapped in the potential well of the ion beam. To investigate such electron cloud effects it is important to have the same vacuum and especially beam-pipe wall conditions compared to a driver. A main disadvantage of superconducting magnets is their greater cost if used in small quantity (< 100 magnets). SC magnets also limit access to the magnet cold mass. For instance the implementation of steering coils increases complexity.

4.2 Induction Cores & Pulsers

Figure 6 shows the different voltage waveforms which have to be generated by the IBX induction cells. This is reflected in the usage of three separate induction core types in the actual cell design, which is schematically depicted in figure 7. Each half lattice period (i.e. quadrupole magnet) in IBX will include an induction acceleration gap. The main acceleration pulse (+100 kV/gap) is generated by bulk Metglas cores with a lumped-element pulse forming network. After exercising a high-gradient tilt waveform (see

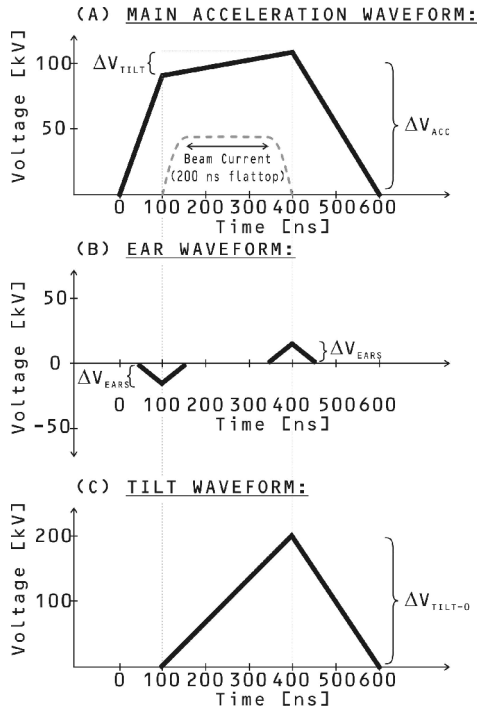

Fig. 6: IBX will incorporate agile waveform control.

figure 7c) up to 200 kV/gap over several induction cells in the beginning of the accelerator (V-section in figure 1) the velocity tilt must be maintained throughout the accelerator by applying a small tilt voltage (~ 5 kV) on top of the main acceleration pulse (see figure 7a). This tilt voltage will be generated by smaller Finemet cores and linear solid state amplifiers. Since solid state pulsers are extremely flexible the tilt voltage can be modified easily for different longitudinal beam physics experiments. Regulation of the main accelera-

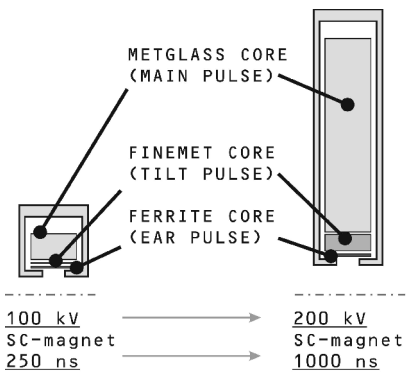

Fig. 7: IBX induction cells will use different core materials to produce the required pulse waveforms shown in figure 6. For longer ion beam pulse lengths and higher gap voltages more core material is needed. This figure demonstrates the impact on size when going from a 250 ns / 100 kV cell to a 1000 ns / 200 kV cell. At the same time the core weight would increase from ~ 200 kg to ~ 4500 kg.

tion waveform to less than 1% can also be achieved using these same cores and pulsers. For the ear waveforms, which require the highest magnetization rate, a third core component using Ferrite material with solid state pulsers can be used. Their main function is to apply beam “confining” ear pulses (~ 5 kV) in each induction cell to counteract longitudinal beam spreading due to space charge. As a further advantage, solid state pulsers can be easily integrated into the accelerator control system. Since the waveform is generated by arbitrary waveform generators, feedback loops can correct errors in the applied voltage pulses even during a single beam shot in subsequent cells.

For these reasons solid state technology constitutes a core component of IBX permitting a multitude of never before conceived experiments. However, this solid state technology as well as the low loss magnetic material has high costs.

5. SUMMARY

Main parameters and the most consequential technology choices of the planned Integrated Beam Experiment (IBX) pursued by the Heavy Ion Fusion Virtual National Laboratory (HIF-VNL) have been described. The total project cost including R&D is currently expected to be in the range of 80 M\$. Following project approval and a one year conceptual design effort IBX’s first operation could begin after a 5-year design and construction schedule. The integrative nature of IBX with source-to-target beam propagation would unfold a whole new field for investigating and exploring heavy ion fusion concepts.

6. REFERENCES

- [1] B.G. LOGAN, et al: “U.S. Heavy Ion beam Science towards Inertial Fusion Energy”, to be published Proc. 19th IAEA Fusion Energy Conference, Lyon, France (2002) (<http://www.iaea.org/programmes/ripc/physics/>)
- [2] A. FALTENS, N.Y. LI, G. RITCHIE, D. SHUMAN: “APulsed Elliptical Quadrupole Array for Transport of Multiple High Current Beams”, Proc. 1999 Particle Accelerator Conference, New York, USA (1999) p 3339-3341
- [3] N.N. MARTOVETSKY, R.R. MANAHAN: “Focusing Magnets for HIF based on Racetracks”, IEEE Transactions on Applied Superconductivity **11** (1 Part 2) p 1506-1509 (2001)
- [4] A. LIETZKE, et al: “Development of Superconducting Quadrupoles for Heavy Ion Fusion”, Proc. 2001 Particle Accelerator Conference, Chicago, USA (2001) p 3436-3438