

UC Irvine

UC Irvine Previously Published Works

Title

Phylogeny of the malarial genus Plasmodium, derived from rRNA gene sequences.

Permalink

<https://escholarship.org/uc/item/2f3741pf>

Journal

Proceedings of the National Academy of Sciences of the United States of America, 91(24)

ISSN

0027-8424

Authors

Escalante, AA

Ayala, FJ

Publication Date

1994-11-22

DOI

10.1073/pnas.91.24.11373

Copyright Information

This work is made available under the terms of a Creative Commons Attribution License, available at <https://creativecommons.org/licenses/by/4.0/>

Peer reviewed

Phylogeny of the malarial genus *Plasmodium*, derived from rRNA gene sequences

(*Plasmodium falciparum*/host switch/small subunit rRNA/human malaria)

ANANIAS A. ESCALANTE AND FRANCISCO J. AYALA*

Department of Ecology and Evolutionary Biology, University of California, Irvine, CA 92717

Contributed by Francisco J. Ayala, August 5, 1994

ABSTRACT Malaria is among mankind's worst scourges, affecting many millions of people, particularly in the tropics. Human malaria is caused by several species of *Plasmodium*, a parasitic protozoan. We analyze the small subunit rRNA gene sequences of 11 *Plasmodium* species, including three parasitic to humans, to infer their evolutionary relationships. *Plasmodium falciparum*, the most virulent of the human species, is closely related to *Plasmodium reichenowi*, which is parasitic to chimpanzee. The estimated time of divergence of these two *Plasmodium* species is consistent with the time of divergence (6–10 million years ago) between the human and chimpanzee lineages. The *falciparum*–*reichenowi* clade is only remotely related to two other human parasites, *Plasmodium malariae* and *Plasmodium vivax*, which are also only remotely related to each other. Thus, the parasitic associations of the *Plasmodium* species with their human hosts are phylogenetically independent. The remote phylogenetic relationship between the two bird parasites, *Plasmodium gallinaceum* and *Plasmodium lophurae*, and any of the human parasites provides no support for the hypothesis that infection by *Plasmodium falciparum* is a recent acquisition of humans, possibly coincident with the onset of agriculture.

Malaria counts among the worst scourges of mankind. The global incidence of malaria is estimated to be 110 million persons per year, some 270 million carry the parasite, and the number of people at risk is 2100 million (ref. 1, p. 30). The number of human deaths in subSaharan Africa alone is estimated at 1.5–3 million annually (2).

Malaria is a parasitic disease caused by protozoa of the genus *Plasmodium* (phylum Apicomplexa Levine 1970) that parasitize reptiles, birds, or mammals. Four species are parasitic to humans: *Plasmodium falciparum*, *Plasmodium malariae*, *Plasmodium ovale*, and *Plasmodium vivax*. Most virulent is *P. falciparum*, the agent of the lethal tertian malaria. It has been suggested (ref 3, cited in ref. 4) that the virulence of *P. falciparum* is derived from it recently becoming a human parasite by way of a host switch from a nonhuman parasite. Support from this hypothesis has been provided by Waters *et al.* (4–6) who concluded that *P. falciparum* is phylogenetically more closely related to those *Plasmodium* species parasitic to birds than to the species that parasitize humans or primates.

To reconstruct the phylogeny of the genus and, particularly, to test the hypothesis that *P. falciparum* is monophyletic with the bird parasites, we have analyzed small subunit (SSU) rRNA genes of 11 *Plasmodium* species, including *Plasmodium reichenowi*, a chimpanzee parasite, which was not considered in refs. 4–6. Our analysis shows that the closest relative of *P. falciparum* among the taxa examined is *P. reichenowi* and that the clade formed by these two species

is only remotely related to other *Plasmodium* species, including those parasitic to birds and other human parasites, such as *P. vivax* and *P. malariae*.

MATERIALS AND METHODS

We have investigated the 18S SSU rRNA sequences of the 11 *Plasmodium* species listed in Table 1. This table also gives the known host and geographical distribution. The sequences are for type A genes, which are expressed during the asexual stage of the parasite in the vertebrate host, whereas the SSU rRNA type B genes are expressed during the sexual stage in the vector (12). Four or five copies of type A genes have been found in *P. cynomolgi* that are all evolving in a concerted fashion (13).

The 11 *Plasmodium* sequences were aligned by means of the CLUSTAL-V program (14). Segments for which a reliable alignment could not be inferred were eliminated. Moreover, the available sequence of *P. mexicanum* is not complete. Thus, only a 1620-bp segment was considered in our analysis. The alignment is available upon request from F.J.A.

Phylogenetic relationships are inferred by two methods: (i) Neighbor joining (NJ) (15) with Tamura's three-parameter distance (16) takes into account the possibility of high bias in the transition/transversion ratio and in G+C content, as is the case in these *Plasmodium* genes. The estimate for G+C content used is the average for all the sequences (39%; range, 37–41%). Distances are calculated using all aligned nucleotides and eliminating gaps. The reliability of the trees is assessed by the bootstrap method (17) with 1000 pseudoreplications. All NJ analyses are performed using the program MEGA Version 1.0 (18).

(ii) Maximum likelihood (ML) (19) assumes specific transition/transversion ratios. Given that a strong bias in G+C content occurs in these sequences, we used several transition/transversion ratios (2, 4, 6, 8, 10, and 15), all of which yielded very similar results. Alternative tree topologies are compared using the Kishino and Hasegawa test (20). These analyses are performed by means of the algorithm DNAML of the PHYLIP package, Version 3.5c (ref. 21; program available from J. Felsenstein, Department of Genetics, University of Washington, Seattle).

The tree root is estimated by the algorithm DNAMLK of the PHYLIP program, which assumes a molecular clock. To verify this assumption, trees obtained by the DNAML and the DNAMLK algorithms are compared by the test in ref. 20. If the trees are not statistically different, one can, at least provisionally, assume that the gene is evolving as a molecular clock and, therefore, accept the tree root position estimated by DNAMLK.

We also estimate the tree root by a second method. Three independent alignments of the 11 *Plasmodium* species are

The publication costs of this article were defrayed in part by page charge payment. This article must therefore be hereby marked "advertisement" in accordance with 18 U.S.C. §1734 solely to indicate this fact.

Abbreviations: ML, maximum likelihood; My, million years; NJ, neighbor joining; SSU rRNA, small subunit rRNA.
*To whom reprint requests should be addressed.

Table 1. *Plasmodium* species and their hosts and accession numbers for the SSU rRNA sequences

Code	Species	Host	Geographic distribution	Accession number	Ref.
Pfa	<i>P. falciparum</i>	Human	Tropics worldwide	M19172	7
Pma	<i>P. malariae</i>	Human	Worldwide	M54897	8
Pvi	<i>P. vivax</i>	Human	Tropics worldwide	X13926	9
Pre	<i>P. reichenowi</i>	Chimpanzee	African tropics	Z25819	*
Pfr	<i>P. fragile</i>	Monkey (<i>Macaca sinica</i>)	Asian tropics	M61722	4
Pkn	<i>P. knowlesi</i>	Monkey (<i>Macaca fascicularis</i>)	Asian tropics	L07560	6
Pcy	<i>P. cynomolgi</i>	Monkey (<i>M. fascicularis</i> & <i>Presbytis</i> spp.)	Asian tropics	L07559	6
Pbe	<i>P. berghei</i>	Rodent	African tropics	M14599	10
Pga	<i>P. gallinaceum</i>	Bird (<i>Gallus gallus</i>)	Asia	M61723	4
Plo	<i>P. lophurae</i>	Bird	Old World	X13706	11
Pme	<i>P. mexicanum</i>	Lizard (<i>Sceloporus</i> spp.)	North America	L11716	†

*A. W. Thomas, M. Dumbled, B. Mons, D. Narum, and A. P. Waters (1993) GenBank, unpublished sequence.

†J. B. Dame, C. A. Yowell, S. R. Telford, Jr., D. Higgins, and T. F. McCutchan (1993) GenBank, unpublished sequence.

made using three different outgroup species, *Babesia bovis*, *Theileria parva*, and *Sarcocystis fusiformis* (Table 2), and a fourth alignment incorporating jointly all three outgroup taxa and the 11 *Plasmodium* species. These alignments are available upon request from A.A.E. The three outgroup genera belong to the Apicomplexa phylum; *Babesia* and *Theileria* are in the class Hematozoa to which *Plasmodium* also belongs, whereas *Sarcocystis* belongs to the class Coccidia. *Toxoplasma gondii* (which belongs to the class Coccidia and the family Sarcocystidae, the same as *S. fusiformis*) was also used as an outgroup, but the root of the *Plasmodium* tree could not be unambiguously determined, which suggests that for the present purposes *Toxoplasma* may be genetically far too removed from *Plasmodium*. Phylogenetic relationships between the outgroup taxa and the *Plasmodium* species were inferred by the two methods mentioned above.

RESULTS

Table 3 shows the genetic distances among the 11 *Plasmodium* species. Fig. 1 shows the NJ tree derived from this distance matrix. The numbers on the branches are the bootstrap values that indicate the percent number of times out of 1000 replications that the species in the cluster to the right appear as a clade. The phylogeny obtained by ML (DNAML or DNAMLK) has precisely the same topology as the one shown in Fig. 1. Alternative topologies give low bootstrap values and are significantly worse (by the method of ref. 20) than the tree shown in Fig. 1.

P. falciparum clusters with *P. reichenowi*, the chimpanzee parasite, with bootstrap reliability of 100%. *P. vivax* clusters unambiguously (100%) with the three monkey parasites (*P. fragile*, *P. knowlesi*, and *P. cynomolgi*). The two bird parasites (*P. gallinaceum* and *P. lophurae*) cluster with *P. mexicanum*, the reptile parasite. *P. malariae*, a human parasite, and *P. berghei*, a rodent parasite, do not closely cluster with any of the other clades nor with each other.

The root of the tree in Fig. 1 defines two major clusters, one with the rodent and monkey parasites and the human *P. vivax* and the second cluster with all other species, which is consistent with ref. 6. The root is determined by using the

Table 2. Three outgroup species and accession number for the SSU rRNA sequences

Code	Species	Accession number	Ref.
Bbo	<i>Babesia bovis</i>	L19077	22
Tpa	<i>Theileria parva</i>	L02366	23
Sfu	<i>Sarcocystis fusiformis</i>	U03071	*

*O. J. Holmdahl, J. G. Mattsson, A. Uggla, and K. Johansson (1993) GenBank, unpublished sequence.

DNAMLK model that assumes that all lineages are evolving at the same rate. The test of ref. 20 shows that the assumption of a molecular clock is not warranted for the whole data set. However, if *P. mexicanum* is removed, the data set is consistent with the molecular clock assumption, and the root appears in the same location as in Fig. 1.

Table 4 gives the pairwise genetic distances for the 11 *Plasmodium* and the three outgroup species. Fig. 2 depicts the NJ tree derived from this distance matrix. As in Fig. 1, *falciparum* clusters with *reichenowi*, *vivax* clusters with the monkey species, and also, the two bird species cluster with *P. mexicanum*, the reptile parasite. Moreover, *P. malariae* and *P. berghei* cluster with the *vivax*-monkey clade with high (95%) reliability. The pair *falciparum*-*reichenowi* appears as a sister group to all other *Plasmodium* species, but only in 64% of the bootstrap replications (70% or higher is the value required for statistical reliability—ref. 24).

We have also obtained three separate *Plasmodium* phylogenies by using in turn each of the three outgroup species. As in Figs. 1 and 2, *P. falciparum* and *P. reichenowi* appear as sister taxa in all three trees, with very high reliability (91–100%). *P. vivax* and the three monkey species also form a reliable cluster (99–100%). The two bird *Plasmodium* species cluster with the reptile *P. mexicanum* when *Babesia* or *Theileria* are used as outgroups (95–98% reliability); but not when *Sarcocystis* is the outgroup. Trees with *Babesia* and *Theileria* as outgroups show the couplet *falciparum*–

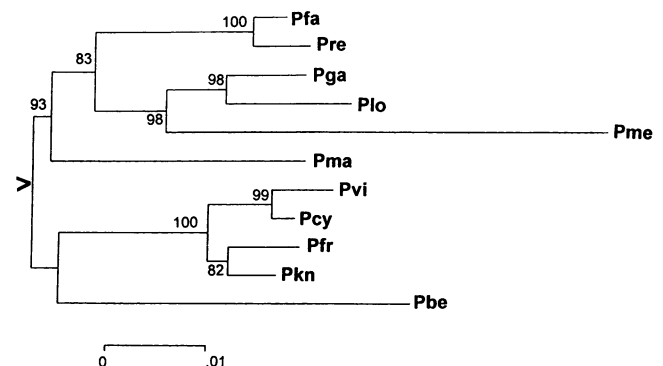

Fig. 1. Phylogenetic relationships among 11 *Plasmodium* species inferred from the SSU rRNA gene sequences (see Table 1 for abbreviations of species names). The tree is derived by the NJ method (15) from the matrix of genetic distances given in Table 3. The scale is in units of substitutions per site. The numbers on the branches are bootstrap values based on 1000 replications and indicate the percent of cases in which all the species to the right appear as a cluster. The root (arrowhead on left) is located by a ML method, implemented in the DNAMLK program of PHYLIP, which assumes constant evolutionary rate.

Table 3. Genetic distances between the SSU rRNA sequences of 11 *Plasmodium* species

	Nucleotide substitutions, no. per site										
	Pfa	Pma	Pvi	Pre	Pfr	Pkn	Pcy	Pbe	Pga	Plo	Pme
Pfa		0.051	0.058	0.009	0.051	0.049	0.052	0.061	0.043	0.045	0.069
Pma	0.006		0.058	0.054	0.053	0.053	0.054	0.066	0.047	0.053	0.081
Pvi	0.006	0.006		0.060	0.023	0.018	0.009	0.063	0.056	0.061	0.091
Pre	0.002	0.006	0.007		0.053	0.052	0.053	0.065	0.045	0.047	0.072
Pfr	0.006	0.006	0.004	0.006		0.012	0.018	0.059	0.056	0.062	0.085
Pkn	0.006	0.006	0.003	0.006	0.003		0.016	0.058	0.051	0.056	0.081
Pcy	0.006	0.006	0.002	0.006	0.003	0.003		0.058	0.052	0.057	0.085
Pbe	0.007	0.007	0.007	0.007	0.006	0.006	0.006		0.068	0.074	0.095
Pga	0.005	0.006	0.006	0.006	0.006	0.006	0.006	0.006		0.021	0.060
Plo	0.006	0.006	0.007	0.006	0.007	0.006	0.006	0.007	0.004		0.061
Pme	0.007	0.008	0.008	0.007	0.008	0.008	0.008	0.008	0.007	0.007	

Data are expressed as nucleotide substitutions per site (mean) and based on 1620 nucleotides sequenced in all species (above diagonal). Below the diagonal are the standard errors. The distances are calculated with Tamura's three-parameter method (16) using transitions and transversions. Abbreviations are in Table 1.

reichenowi as a sister clade to all other species, whereas this couplet is the sister clade to the bird parasites, although without dependable bootstrap reliability, when *Sarcocystis* is the outgroup. In these trees, *P. malariae* and *P. berghei* appear phylogenetically associated with the *vivax*-monkey cluster, but without consistent reliability.

Two ML phylogenies derived from comparisons with the three outgroup species are shown in Fig. 3. These two trees are not statistically different from each other by the test of ref. 20. The one topological difference between them is that in the left-side tree the bird-plus-reptile species are a sister clade to the rest of *Plasmodium* species other than *falciparum* and *reichenowi*, which is the configuration found in Fig. 2; whereas in the right-side tree, the bird-plus-reptile species are the sister clade of *falciparum*-*reichenowi*, as in Fig. 1.

DISCUSSION

We have tested the hypothesis that "*P. falciparum* is monophyletic with the avian subgroup [of *Plasmodium* species], indicating that *P. falciparum* and avian parasites share a relatively recent avian progenitor" (ref. 4, p. 3140; see refs. 5 and 6), which is "consistent with the commonly held notion that infection by *P. falciparum* is a recent acquisition of humans and possibly coincident with the onset of an agriculture-based life style" (ref. 4, p. 3141). Our results do not support these statements; rather, *P. falciparum* is monophyl-

etic with *P. reichenowi*, a chimpanzee parasite, but shares only a distant common ancestor with the avian parasites. The results are ambiguous concerning whether the *falciparum*-*reichenowi* clade is more closely related to the avian parasites than to other clades.

Our analysis confirms that *P. falciparum* is only remotely related to the other human *Plasmodium* parasites, *P. vivax* and *P. malariae* (and these two to each other). The evolutionary divergence of these three human parasites greatly predates the origin of the hominids. Thus, the parasitic associations of these *Plasmodium* species with humans are phylogenetically independent. This result is consistent with the diversity of physiological and epidemiological characteristics of these three *Plasmodium* species (25, 26).

Various estimates exist of the rate of nucleotide substitution in SSU rRNA genes. Based on the study of prokaryotic endosymbionts of aphids, Moran *et al.* (27) have estimated a rate of 1-2% per 50 million years (My; rounded from actual estimates ranging from 0.0076 to 0.0232). This is consistent with earlier estimates of 1% per 50 My (28, 29). Differences between estimates may be due to statistical variance and to heterogeneous evolutionary rates in different lineages or at different times.

Variation in estimates of rRNA evolutionary rates may also arise because the set of nucleotides that are compared differ from one to another case. Generally, as the set of lineages compared becomes more ancient, and hence more diverse, it becomes increasingly difficult to align the more variable

Table 4. Genetic distances between the SSU rRNA sequences of 11 species of *Plasmodium* and three other Apicomplexa species

	Nucleotide substitutions, no. per site													
	Pfa	Pma	Pvi	Pre	Pfr	Pkn	Pcy	Pbe	Plo	Pga	Pme	Bbo	Tpa	Sfu
Pfa		0.019	0.024	0.004	0.020	0.020	0.020	0.022	0.013	0.014	0.026	0.225	0.168	0.185
Pma	0.004		0.018	0.024	0.017	0.015	0.015	0.016	0.020	0.018	0.030	0.243	0.178	0.191
Pvi	0.004	0.004		0.026	0.007	0.004	0.003	0.017	0.021	0.019	0.035	0.235	0.173	0.188
Pre	0.002	0.005	0.005		0.024	0.023	0.023	0.025	0.015	0.017	0.030	0.225	0.170	0.186
Pfr	0.004	0.004	0.002	0.005		0.002	0.003	0.014	0.022	0.020	0.033	0.239	0.176	0.191
Pkn	0.004	0.004	0.002	0.004	0.001		0.000	0.013	0.019	0.018	0.031	0.239	0.176	0.191
Pcy	0.004	0.004	0.002	0.004	0.002	0.000		0.013	0.019	0.018	0.031	0.239	0.176	0.191
Pbe	0.004	0.004	0.004	0.005	0.003	0.003	0.003		0.024	0.022	0.035	0.242	0.176	0.192
Plo	0.003	0.004	0.004	0.004	0.004	0.004	0.004	0.004		0.005	0.024	0.237	0.178	0.191
Pga	0.003	0.004	0.004	0.004	0.004	0.004	0.004	0.004	0.002		0.020	0.237	0.175	0.189
Pme	0.005	0.005	0.005	0.005	0.005	0.005	0.005	0.005	0.004	0.004		0.246	0.182	0.195
Bbo	0.016	0.016	0.016	0.016	0.016	0.016	0.016	0.016	0.016	0.016	0.017		0.110	0.144
Tpa	0.013	0.014	0.013	0.013	0.014	0.014	0.014	0.014	0.014	0.013	0.014	0.010		0.079
Sfu	0.014	0.014	0.014	0.014	0.014	0.014	0.014	0.014	0.014	0.014	0.014	0.012	0.008	

Data are expressed as nucleotide substitutions per site (mean) and based on 1340 nucleotides aligned for all species (above diagonal). Below the diagonal are the standard errors. The distances are calculated with Tamura's three-parameter method (16) using transitions and transversions. Abbreviations are in Tables 1 and 2.

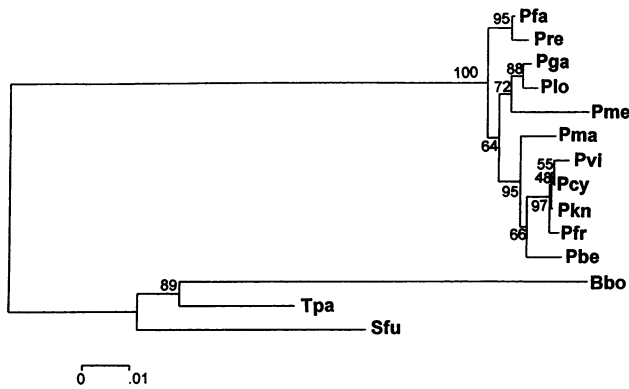

FIG. 2. Phylogenetic tree of 11 *Plasmodium* species and three outgroup species (see Tables 1 and 2 for abbreviations), derived by the NJ method from the genetic distance matrix given in Table 4. Other information is as in Fig. 1.

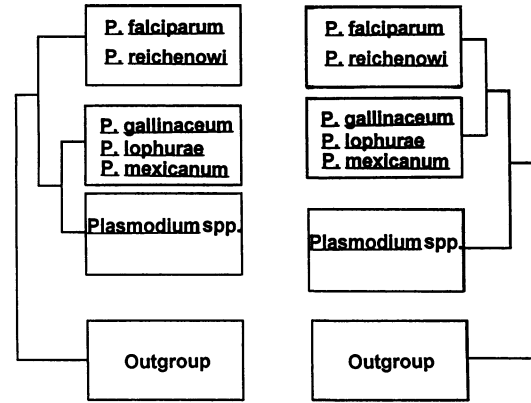

FIG. 3. Two ML phylogenetic trees obtained by grouping 11 *Plasmodium* species as indicated (the six unlisted species are grouped as *Plasmodium* spp.). Statistically, the two topologies are not significantly different.

regions of the homologous genes. Consequently, only the more conserved regions of the molecule are compared, and the estimated rate of evolution becomes smaller. This effect is clearly apparent by comparing Table 3 (where 1620 bp are taken into account) with Table 4 (where only 1340 bp could be reliably aligned): the substitution rates in Table 4 are about half those in Table 3.

Table 5 gives divergence-time estimates for various lineages; the rate of 1% for 50 My is used in column a for the data in Table 4, rates of 2% (column b) and 1% (column c) per 50 My are used for the data in Table 3. From Table 5, columns a and b, the divergence time between *P. falciparum* and *P. reichenowi* is estimated as 10.5 ± 5.0 My and 11.2 ± 2.5 My, respectively. These estimates are consistent with the time of divergence between the lineages of humans and chimpanzees (6–10 My; see, e.g., ref. 30), their corresponding hosts. The rate of 1% per 50 My would seem appropriate for the more conserved fraction of the molecule examined in Table 4 but not for the complete molecule (Table 3), since it yields a divergence estimate of 22.5 My, which is much too ancient for the divergence between humans and chimpanzee. (Of course, the theoretical possibility exists that the two parasites, *falciparum* and *reichenowi*, diverged much before their host species.) For the data in Table 3, the rate of 2% per 50 My yields a 95% confidence interval of 6.2–16.2 My, which is consistent with the divergence of the hosts.

Table 5, columns a and b, yields estimates of 11.7 ± 5.0 My and 20.9 ± 3.8 My for the average divergence between the human *P. vivax* and the monkey parasites, estimates that are low for the divergence between the Old World monkeys and the hominoids. Two possible explanations for this discrepancy are (i) the rRNA genes in these *Plasmodium* species are evolving at a slower rate than in *falciparum* and *reichenowi*

or (ii) the phylogeny of these parasites does not parallel the phylogeny of the hosts, so that parasite or host polymorphism may exist (now or in the past), or lateral transfers may have occurred. (We mean by parasite polymorphism that a given host species is parasitized by more than one of these *Plasmodium* species; by host polymorphism, we mean that a given *Plasmodium* species parasitizes more than one of these host species; by lateral transfer, we mean that a parasite of one species may be acquired by another species.) A third possibility is that Tamura's method for estimating distances is not properly correcting for the actual number of substitutions that have occurred. Consistent with hypothesis ii is that *P. cynomolgi* clusters with human *P. vivax*, rather than with the two other macaque parasites. Moreover, *P. cynomolgi* parasitizes *Macaca fascicularis* and other species, whereas *M. fascicularis* is also parasitized by *P. knowlesi* (25, 31).

The rate of 1% per 50 My applied to the data in Table 3 yields a divergence time of 152.5 ± 17.5 My between the reptile and bird *Plasmodium* (Table 5, column c), which is consistent with the divergence time of the birds from their closest reptile lineages. This may imply that the other rates used in Table 5, columns a and b, are much too fast in this case. But it may also be that the patterns mentioned in the previous paragraph may be operating. A discrepancy in evolutionary rates was noted earlier: the reptile parasite *P. mexicanum* appears to evolve at a faster rate than other *Plasmodium* lineages.

Pairwise comparisons among the four main *Plasmodium* lineages yield an estimate of 151.5 ± 17.5 My (Table 5, column c) for the origin of these lineages. This estimate would imply that the genus *Plasmodium* originated about the time of divergence of birds from reptiles, a conjecture consistent

Table 5. Divergence time between *Plasmodium* lineages

Lineage comparison	Time since divergence, My			Paleontological host data	
	a	b	c	Event	Time, My
1. <i>falciparum</i> vs. <i>reichenowi</i>	10.0 ± 5.0	11.2 ± 2.5	22.5 ± 5.0	Human–chimp	8
2. <i>vivax</i> vs. monkey	11.7 ± 5.0	20.9 ± 3.8	41.7 ± 7.5	Origin of hominoids	30
3. <i>mexicanum</i> vs. bird	55.0 ± 10.0	76.2 ± 8.8	152.5 ± 17.5	Origin of birds	150
4. <i>falciparum</i> vs. <i>vivax</i> vs. <i>mexicanum</i> vs. <i>malariae</i> vs. <i>berghei</i>	52.4 ± 10.0	75.7 ± 8.8	151.5 ± 17.5	Origin of genus <i>Plasmodium</i>	?
5. <i>Plasmodium</i> vs. outgroup	502.5 ± 37.50	—	—	Origin of Apicomplexa phylum	?

Estimates are obtained as follows: Columns: a, rate 1% per 50 My, distances from Table 4; b, rate 2% per 50 My, distances from Table 3; c, rate 1% per 50 My, distances from Table 3. Standard errors are calculated from distance errors. Lineage comparisons: 2, average between *vivax* and each of the three monkey parasites; 3, average between *mexicanum* and each of the two bird parasites; 4, average of all comparisons between species of the five *Plasmodium* lineages; 5, average of *Plasmodium* species each separately compared with each of the three outgroup species.

with other considerations (32). Some authors (for review, see ref. 33) have questioned whether the reptile parasites should be included within the genus *Plasmodium*. Our analysis favors the affirmative, since *P. mexicanum* generally clusters within the set of all other *Plasmodium* species. (The only exception is the tree obtained with *Sarcocystis* as outgroup, in which *P. mexicanum* is the sister group to the other *Plasmodium* species, but with a bootstrap value of only 61%.)

Two of the three outgroup species used, *Babesia bovis* and *Theileria parva*, belong to the class Hematozoa, the same as *Plasmodium*, although they belong to different families. The third outgroup species, *S. fusiformis*, belongs to the Coccidia, which is thought to be the closest class to the Hematozoa, and perhaps ancestral to it. Table 5 gives an estimate of 502.5 ± 37.5 My as the time of divergence between *Plasmodium* and the three outgroups. This is almost certainly an underestimate of the time of origin of the Apicomplexa phylum for two reasons. (i) These outgroup species are presumed to be less distantly related to *Plasmodium* than taxa from other Apicomplexa clades. (ii) The rate of nucleotide substitution used, 1% per My, is probably too high for the set of nucleotides compared between the *Plasmodium* and the outgroup species. This rate is also too high for comparisons between distant *Plasmodium* species (Table 5, lineage comparisons 3 and 4; compare column a with column b or c).

We are grateful to Eladio Barrio, Walter Fitch, Richard Hudson, Anthony James, and Andrés Moya for comments that have contributed to improving this manuscript. A.A.E. has been supported by fellowships from the Fundación Gran Mariscal de Ayacucho-Latin American Program of American Universities and the New Technologies Program from Banco Interamericano de Desarrollo-Consejo Nacional de Ciencia y Tecnología, Venezuela. F.J.A. acknowledges the support of National Institutes of Health Grant GM42397.

- World Health Organization (1991) *Tropical Diseases: Progress in Research 1989-1990* (W.H.O., Geneva).
- Selormey, J. A. (1994) *Afr. Technol. Forum* 7, 27-28.
- Boyd, M. F. (1949) in *Malariaology*, ed. Boyd, M. F. (Saunders, Philadelphia), Vol. 1, pp. 3-25.
- Waters, A. P., Higgins, D. G. & McCutchan, T. F. (1991) *Proc. Natl. Acad. Sci. USA* 88, 3140-3144.
- Waters, A. P., Higgins, D. G. & McCutchan, T. F. (1993) *Parasitol. Today* 9, 246-250.
- Waters, A. P., Higgins, D. G. & McCutchan, T. F. (1993) *Mol. Biol. Evol.* 10, 914-923.
- McCutchan, T. F., de la Cruz, V. F., Lal, A. A., Gunderson, J. H., Elwood, H. J. & Sogin, M. L. (1988) *Mol. Biochem. Parasitol.* 28, 63-68.
- Goman, M., Mons, B. & Scaife, J. G. (1991) *Parasitology* 45, 281-288.
- Waters, A. P. & McCutchan, T. F. (1989) *Nucleic Acids Res.* 17, 2135.
- Gunderson, J. H., McCutchan, T. F. & Sogin, M. L. (1986) *J. Protozool.* 33, 525-529.
- Waters, A. P., Unnasch, T., Wirth, A. P. & McCutchan, T. F. (1989) *Nucleic Acids Res.* 17, 1763.
- Waters, A. P., Syn, C. & McCutchan, T. F. (1989) *Nature (London)* 342, 438-441.
- Corredor, V. & Enea, V. (1994) *Genetics* 136, 857-865.
- Higgins, D. G., Bleasby, A. J. & Fuchs, R. (1992) *Comput. Appl. Biosci.* 8, 189-191.
- Saitou, N. & Nei, M. (1987) *Mol. Biol. Evol.* 4, 406-425.
- Tamura, K. (1992) *Mol. Biol. Evol.* 9, 678-687.
- Felsenstein, J. (1985) *Evolution* 39, 783-791.
- Kumar, S., Tamura, K. & Nei, M. (1993) MEGA, Molecular Evolutionary Genetics Analysis (Pennsyl. State Univ., University Park), Version 1.0.
- Felsenstein, J. (1981) *J. Mol. Evol.* 17, 368-376.
- Kishino, H. & Hasegawa, M. (1989) *J. Mol. Evol.* 29, 170-179.
- Felsenstein, J. (1989) *Cladistics* 5, 164-166.
- Allsopp, B. A., Baylis, H. A., Allsopp, M. T., Cavalier-Smith, T., Bishop, R. P., Carrington, D. M., Sohanpal, B. & Spooner, P. (1993) *Parasitology* 107, 157-165.
- Allsopp, M. T., Cavalier-Smith, T., de Waal, T. & Allsopp, B. A. (1994) *Parasitology* 108, 147-152.
- Hillis, D. M. & Bull, J. J. (1993) *Syst. Biol.* 42, 182-192.
- Coatney, R. G., Collins, W. E., Warren, M. & Contacos, P. G. (1971) *The Primate Malariae* (Gov. Print. Off., Washington, DC).
- López-Antuñano, F. & Schmunis, G. A. (1993) in *Parasitic Protozoa*, ed. Kreier, J. P. (Academic, New York), 2nd Ed., Vol. 5, pp. 135-265.
- Moran, N. A., Munson, M. A., Baumann, P. & Ishikawa, H. (1993) *Proc. R. Soc. London B* 253, 167-171.
- Ochman, H. & Wilson, A. C. (1987) *J. Mol. Evol.* 26, 74-86.
- Wilson, A. C., Ochman, H. & Prager, E. M. (1987) *Trends Genet.* 3, 241-247.
- Holmes, E. C., Pesole, G. & Saccone, C. (1989) *J. Hum. Evol.* 18, 775-794.
- Collins, W. E. & Aikawa, M. (1993) in *Parasitic Protozoa*, ed. Kreier, J. P. (Academic, New York), 2nd Ed., Vol. 5, pp. 105-133.
- Manwell, R. D. (1955) *Indian J. Malariol.* 9, 247-253.
- Telford, S. R., Jr. (1994) in *Parasitic Protozoa*, ed. Kreier, J. P. (Academic, New York), 2nd Ed., Vol. 7, pp. 1-71.