

Lawrence Berkeley National Laboratory

Recent Work

Title

Advanced Light Source Activity Report 1993

Permalink

<https://escholarship.org/uc/item/2f7094h5>

Author

Cross, J.

Publication Date

1994-10-01

Advanced Light Source

Activity Report 1993

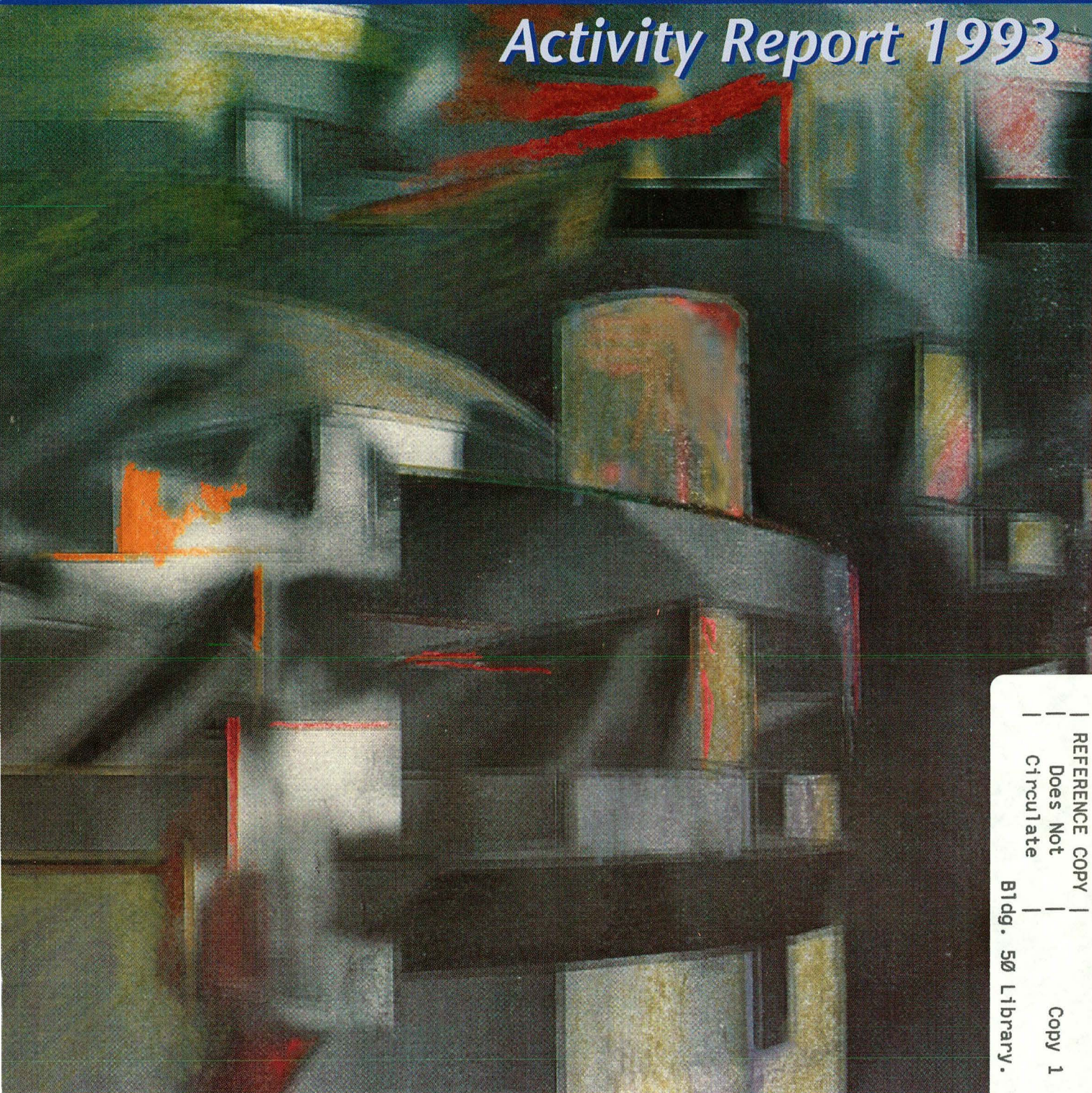

REFERENCE COPY	_____
Does Not Circulate	_____
Copy 1	_____
Bldg. 50 Library.	_____

LBL-35912

Lawrence Berkeley Laboratory
University of California
Berkeley, California 94720
November 1994



The Advanced Light Source is situated in the hills of Berkeley, California, overlooking the San Francisco Bay. Its building incorporates the dome that once housed the 184-Inch Cyclotron built by Lawrence Berkeley Laboratory's founder E.O. Lawrence.

Cover drawing of ALS building by Mark Schwettmann of the University of California at Berkeley. The work originated from an evening art session held at the ALS as part of a Visual Arts course given by Professor Joseph Slusky of the U.C. Architecture Department. The paintings and drawings done by the students, which represented a broad range of media and styles, were displayed in the lobby of the ALS as part of a special exhibit sponsored by David Attwood of LBL's Center for X-Ray Optics and Iran Thomas from the Office of Basic Energy Sciences, Department of Energy.

DISCLAIMER

This document was prepared as an account of work sponsored by the United States Government. While this document is believed to contain correct information, neither the United States Government nor any agency thereof, nor the Regents of the University of California, nor any of their employees, makes any warranty, express or implied, or assumes any legal responsibility for the accuracy, completeness, or usefulness of any information, apparatus, product, or process disclosed, or represents that its use would not infringe privately owned rights. Reference herein to any specific commercial product, process, or service by its trade name, trademark, manufacturer, or otherwise, does not necessarily constitute or imply its endorsement, recommendation, or favoring by the United States Government or any agency thereof, or the Regents of the University of California. The views and opinions of authors expressed herein do not necessarily state or reflect those of the United States Government or any agency thereof or the Regents of the University of California.

Advanced Light Source

Activity Report 1993

The Advanced Light Source (ALS)

produces the world's brightest light in the ultraviolet and soft x-ray regions of the spectrum. The first low-energy third-generation synchrotron source in the world, the ALS provides unprecedented opportunities for research in science and technology not possible anywhere else.

This year marked the beginning of operations and the start of the user research program at the ALS, which has already produced numerous high quality results. A national user facility located at Lawrence Berkeley Laboratory of the University of California, the ALS is available to researchers from academia, industry, and government laboratories.

Contents

Director's Message	2
Operations Overview	6
User Program	8
Users' Executive Committee	12
Industrial Outreach	16
Accelerator Operations	22
Beamline Control System	30
Insertion Devices	32
Experimental Systems	38
Beamline Engineering	44
First Results from User Beamlines	46
Beamlines for 1994-1995	48
Special Events	54
Publications	64
Advisory Panels	69
ALS Staff	71

November 1994

Lawrence Berkeley Laboratory, University of California, Berkeley, CA 94720

This work was supported by the Director, Office of Energy Research, Office of Basic Energy Sciences, Materials Sciences Division, of the U.S. Department of Energy under Contract No. DE-AC03-76SF00098. LBL-35912/9-94

Director's Message

It is with great pleasure that I introduce the first ALS Activity Report, designed to provide an overview of our operations and accomplishments during 1993. It highlights some of the efforts and achievements which contributed to the successful on-time, on-budget completion of the ALS construction project in March, and the on-time, on-target delivery of first light to users' experiments in October.

Project Completed, Design Goal Achieved

The spring marked a grand finale and a new beginning for the ALS. After six years of planning, designing, building, testing, installing, and aligning components, we completed the ALS construction project—ahead of time and within budget. Yet even while celebrating our success, we began a new mode of operations. The ALS project became the ALS Center, a Department of Energy national user facility, and we immediately began gearing our efforts toward providing high-quality photon beams to user experiments.

The ALS storage ring proved a robust and reliable performer from the beginning. In fact, one of the most remarkable aspects of the final phase of the construction project—commissioning the storage ring—was the speed with which it progressed. March 16 was especially significant. It was the day we turned on the rf power system for the first time and immediately stored an electron beam. From then on, the electron-beam current increased almost daily toward the 50-mA goal required for project completion. We surpassed this on March 24, when 65 mA of current were stored in the ring, and just two weeks later we stored 407 mA, exceeding the 400-mA design goal. The fact that the system worked as soon as it was turned on is a testimony to the knowledge and skill of the project team.

ALS Deemed Ready to Operate

The ALS received a grade of "excellent" at our project closeout and safety reviews in late May. The review committees, made up of Department of Energy (DOE) managers and outside consultants, were impressed by the enthusiasm and commitment of the ALS staff, especially our Environment, Health, and Safety personnel, as much as by the quality of the hardware. The committees deemed the ALS "ready to operate," and, thanks to the efforts of the DOE locally and in Washington, the facility received prompt approval of Key Decision 4 (KD4) (the formal permission to operate the facility) from Energy Secretary Hazel O'Leary on July 19. The ALS is the first DOE project to go through the DOE Major Systems Acquisition process, including KD4. The way the ALS and LBL teams handled this challenge was first rate, and set a high standard for other projects to follow.

First Beamlines in Operation

After the highly productive accelerator commissioning during the spring, we scheduled a three month summer shutdown to prepare for the start of user experiments. Several beamlines and two undulators were installed on the experiment floor and every critical component was realigned. We stored beam on the first day after resuming operations and achieved a beam lifetime of 10 hours with a current of 100 mA within a matter of days.

Our much-anticipated transition from new accelerator to operating user facility took place on October 4 when the ALS delivered the first light to a user experiment: the Center for X-Ray Optics microprobe beamline. Two weeks later, on October 18, a transmission grating spectrometer began recording undulator spectra on Beamline 7.0.

The high performance of the ALS accelerator system and the amazing progress in beamline commissioning demonstrate that the ALS team is truly the world leader in this business. From the start of operations for user experiments, the ALS storage ring was able to operate routinely at its design current of 400 mA and energy of 1.5 GeV. Beamline characterization measurements confirmed the realization of undulator and monochromator design goals, and initial experimental results provided a glimpse of the exciting science to come in 1994.

Teamwork is Key to Success

The ALS Dedication Ceremony on October 22 was a reminder that projects like the ALS are built on teamwork. The Dedication brought together all the different groups that make up the "ALS Team" and who have contributed so much to its success. This includes not just the ALS

staff, but also LBL personnel, the Department of Energy, the user community, and local and state government officials. Putting together this team, and fostering the cooperative relationships within, was largely the work of my predecessor Jay Marx. During his six years as ALS Director, he established the foundation on which our current and future achievements are based.

Our user community also deserves credit for our success. I want to thank you for your steady support and assure you that, in return, we are striving to make the ALS the location of choice for scientific and industrial projects utilizing synchrotron radiation.

In conclusion, I want to thank everyone at the ALS for their splendid efforts over the last year. With their help, I am confident that we are ready to meet the challenges and seize the opportunities that lie ahead.

Brian M. Kincaid
Director



MANY MILESTONES MARKED THE ALS' ROAD TO SUCCESS

Start Here



December 1986
ALS Project begins.

December 1987
Congress approves \$18 million for ALS.

August 1988
Ground-breaking ceremony
launches construction.

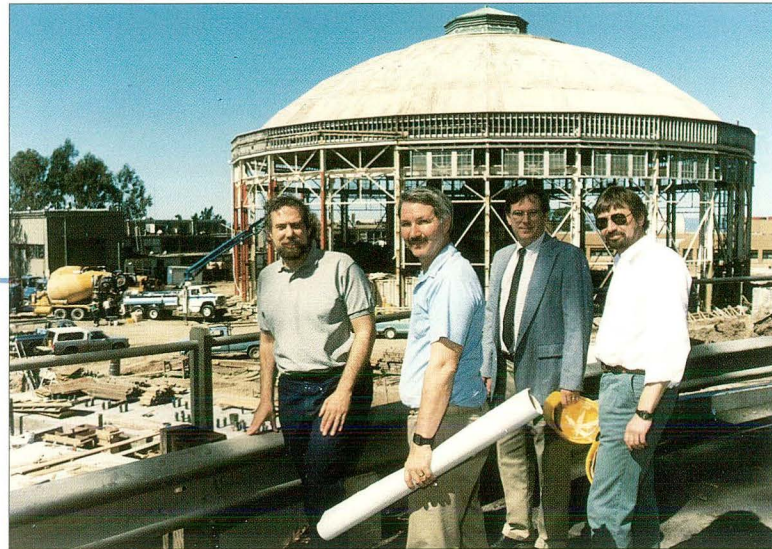

April 1989 Project leaders keep close eye on progress.

October 1989 Last major
concrete pour for floor and foundation.

March 1990 1st section of the booster
lowered into the shielding enclosure.

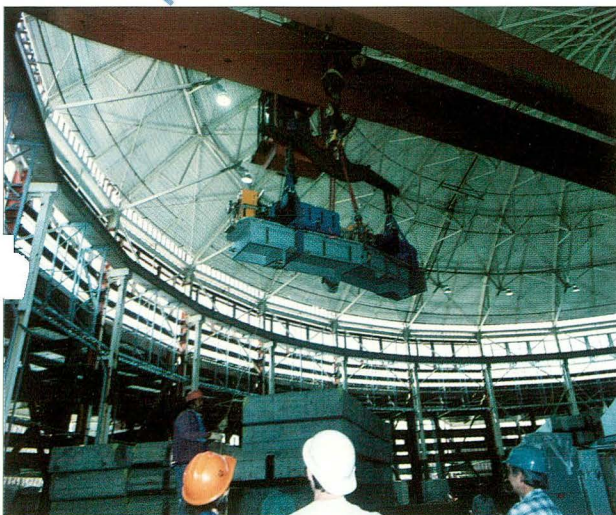

May 1990 Technicians tackle the complex
task of assembling the myriad of magnets
used in the storage ring.

May 1992 Efforts focus on installation of storage-ring components.

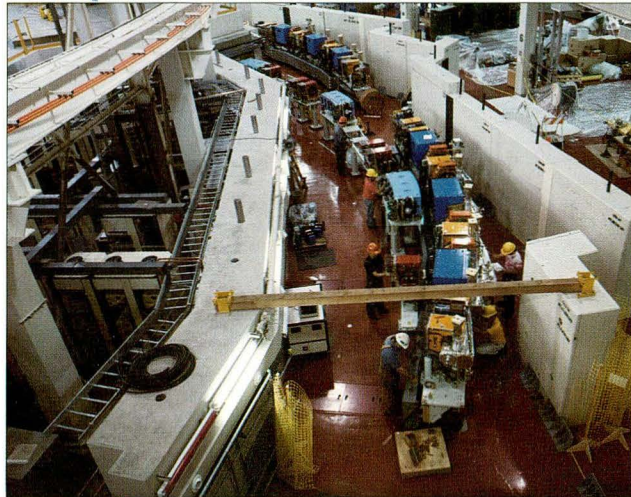

January 1992 Last straight section for storage ring arrives with fanfare.



December 1992 Storage ring is completed.



November 1991 Final storage-ring magnet assembly completed.

March 31, 1993 Beam current reaches 290 mA—exceeding project baseline requirements.

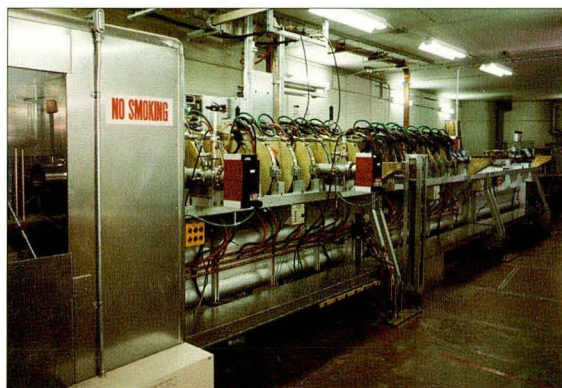

March 1991 Linear accelerator produces first beam on first try.

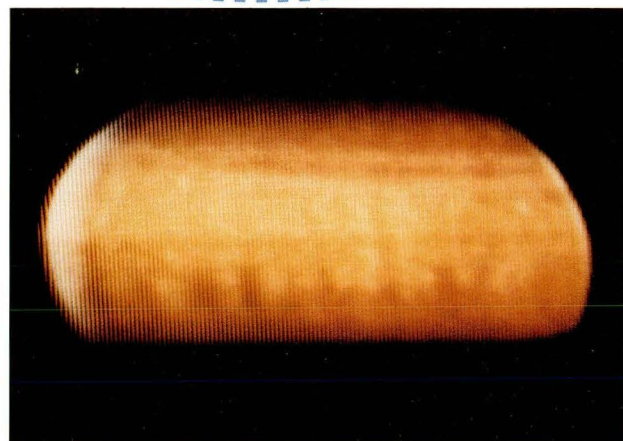

October 4, 1993 First light delivered to a user beamline, signaling the start of user operations.

Operations Overview

The ALS started 1993 with an ambitious set of goals for operations ranging from injecting electrons into the storage ring for the first time to delivering the first light to user experiments.

- Commission the storage ring in two months rather than in the full year originally anticipated.
- Make a smooth and efficient transition from construction project to operating facility.
- Plan and facilitate the summer shutdown to maximize the installation of equipment and other work activities required for the initial set of beamlines.
- Deliver high-quality photon beams to user experiments by October.
- Maintain a reliable operations schedule of beamtime to users.

The fact that we delivered on every one of these items as promised is a success story shared by everyone at the ALS. I don't think any of us, when the list was made, fully grasped the quality and quantity of effort that would be required to match this pace of achievements. In fact, we often discussed our progress in terms of the "miracle of the week" performed by an individual or group which moved us ever closer to the next milestone.

Mode of Operations

A large amount of the administration staff's time and energy during this year was spent on developing an organizational structure and a day-to-day method of operations geared toward efficiency, user-friendliness, and safety. We consolidated our operations scheduling and support for day-to-day user activities into a new Operations Group. The group includes the operations coordinators, who, as the point of contact for user requests and questions, oversee activities on the experiment floor, provide assistance to users, and ensure compliance with safety regulations.

With careful consideration of user requests for beamtime and of the necessary budgetary restraints, we developed a routine operating schedule of 14 8-hour shifts per week: nine dedicated to user experiments and five set aside for maintenance and beam physics experiments. The accelerator physics group has devoted its beamtime to characterizing the beam and improving machine performance. Thanks in large part to their efforts, the ALS achieved an exceptional level of performance in record time, with the ability to deliver beam to user experiments on a reliable schedule, an accomplishment greatly appreciated by the user community.

Our commitment to quality operations is carried forth in part by the appointment of a quality assurance officer, whose functions are to evaluate our performance in meeting expectations, to respond to user suggestions or complaints, and to locate the sources of problems that are affecting our performance. We recognize that all our endeavors must be accompanied by a responsibility to safeguard the health of our employees, our users, and our environment.

As both the number of our users and the industrial interest in using our facility continue to grow, we realize the importance of planning ahead to minimize the length of shutdown periods. To this end, we performed a careful “postmortem” of our summer shutdown activities so that we can develop more efficient, time-saving methods for performing maintenance procedures and installing new beamline equipment and insertion devices.

Future Challenges

I have the responsibility as head of operations to make sure the needs of our customers are met now and in the future, and that we maintain consistent, high quality in both machine performance and user services. I especially want to thank the user community for their valuable suggestions and comments during our initial period of user operations. Hearing from our customers is essential for continued improvements in the quality of light delivered to user experiments and in the work environment at the ALS.

I look forward to our first full year of user operations. I know it will involve at least as many challenges as we faced this year—but I am confident we will generate many more “marvels” to solve them.

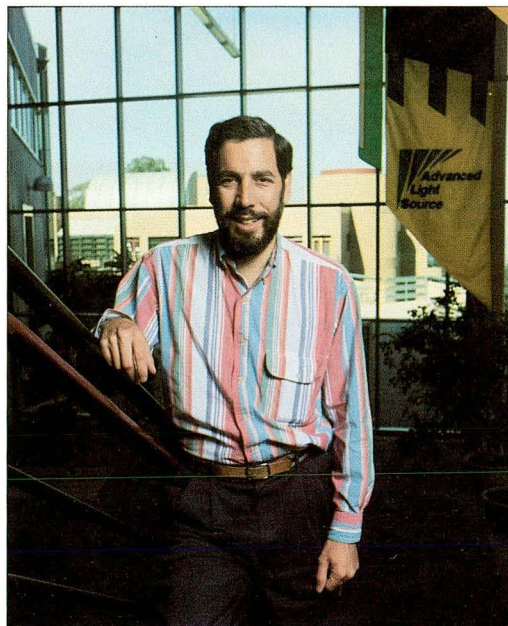

Ben Feinberg
Head of Operations

User Program

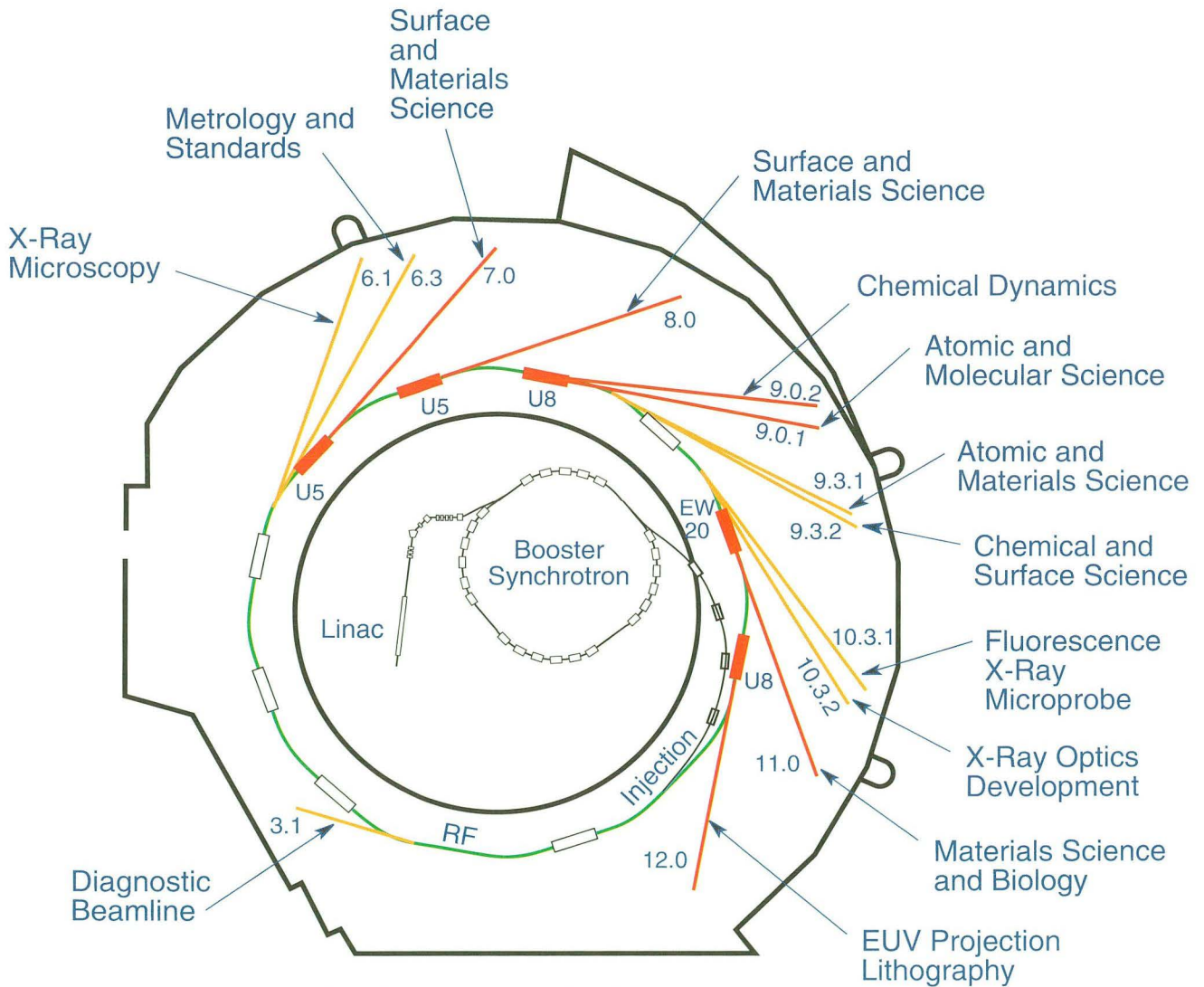

Research Opportunities

The ALS, a national user facility, welcomes researchers from industry, universities, and government laboratories. A third-generation synchrotron-radiation source (specifically designed to make optimum use of insertion devices), the ALS provides opportunities for research in many different fields such as materials science, atomic and molecular physics, chemistry, biology and medicine, earth and environmental sciences, manufacturing technology, and analytical services. The facility is capable of accommodating approximately 46 beamlines and more than 100 experiment endstations.

The ALS storage ring is optimized to run at an energy of 1.5 GeV, although it can run from 1 to 1.9 GeV, allowing flexibility for user operations. The normal maximum operating current is 400 mA in multibunch operation with a lifetime of approximately 12 hours; other filling patterns are available upon request. The spectral range of undulator and wiggler beamlines extends from photon energies of roughly 10 eV to 10 keV. Bend magnets produce radiation from the infrared to about 10 keV.

The scientific program planned for the first years of operation emphasizes the high brightness of soft-x-ray and ultraviolet light available from the ALS. The initial set of beamlines and insertion devices (shown on the facing page and in Table 1) were selected through close

Beamline	Source	Research	Energy Range	Avail.
3.1	Bend magnet	Diagnostic beamline	200 eV	1994
6.1	Bend magnet	High-resolution zone-plate microscopy	250–600 eV	1994
6.3	Bend magnet	Metrology and standards	50–4000 eV	1994
7.0	U5 undulator	Surfaces and materials, spectromicroscopy	70–1200 eV	Now
8.0	U5 undulator	Surfaces and materials	70–1200 eV	Now
9.0.1	U8 undulator ¹	Atomic physics and chemistry	20–300 eV	1994
9.0.2	U8 undulator ¹	Chemical dynamics	5–30 eV	1994/95
9.3.1	Bend magnet	Atomic and materials science	700 eV–6 keV	1994
9.3.2	Bend magnet	Chemical and materials science	50–1500 eV	1994
10.3	Bend magnet	Materials science and advanced microprobe instrumentation	3–12 keV	Now
11.0	EW20 elliptical wiggler	Materials science and biology, magnetic materials	50 eV–10 keV	1995/96
12.0	U8 undulator	EUV projection lithography, optics development	60–320 eV	1995

¹ Will change to U10 in 1995

Table 1. ALS beamlines for 1994–1995.

and extensive interaction with prospective users and the scientific community. See “Beamlines 1994–1995” for more detailed information on the beamlines and endstation capabilities.

As a DOE national user facility, the ALS does not charge users for beam access if their research is non-proprietary. Users performing proprietary research will be charged a fee based on cost recovery for ALS usage. All users are responsible for the day-to-day costs of research (e.g., supplies, phone calls, technical support).

Availability to Researchers

The first beamlines at the ALS began operations in October 1993 and during the initial year of operations most of the experiments will be carried out by Participating Research Teams (PRTs)—groups of researchers with related interests from one or more institutions. The PRT has the primary responsibility for experiment endstation equipment for their associated beamline, and, in return, receives a guaranteed fraction of the ALS operating time. Through a proposal process, a substantial fraction of running time at each beamline will also be made available to independent investigators not affiliated with a PRT. Although largely free from the responsibility of furnishing endstation facilities, independent investigators may choose to provide their own experiment chambers. Four beamlines are expected to be available to independent investigators during 1994: undulator beamlines 7.0 and 9.0.1 and the bend-magnet beamlines 9.3.1 and 9.3.2. Further details may be found in PUB-3104, *ALS Beamlines for Independent Investigators*, which is available on request from the ALS.

User Services

We devoted considerable effort in 1993 to creating a comprehensive ALS user services program designed to streamline users’ access to the facility, ensure compliance with all applicable safety regulations, and provide optimal support for the installation and operation of experiment equipment. In establishing these services and facilities, the ALS User Liaison, Fred Schlachter, worked with the ALS operations and administrative staff to make the ALS as user friendly as possible. New users can appreciate this well-orchestrated program as soon as they arrive at the LBL Reception Center. There the emphasis is on “one-stop shopping” for new users, who can complete their registration forms, obtain ID badges and parking permits, arrange for the safety training they are required to go through as ALS users—all in one location. The Reception center will also assist users from outside the immediate area with housing referrals.

The ALS worked closely with members of the Users’ Executive Committee to plan and prioritize the user support facilities needed by the users to conduct their experiments, and we expect many of these

amenities to be completed in 1994. These facilities include a user machine shop, laboratory, gas storage room, semi-clean and UHV assembly areas, storage spaces, and an on-site inventory of commonly used items such as flanges and floor anchors. Part of Building 7 near the ALS has been set aside for user offices.

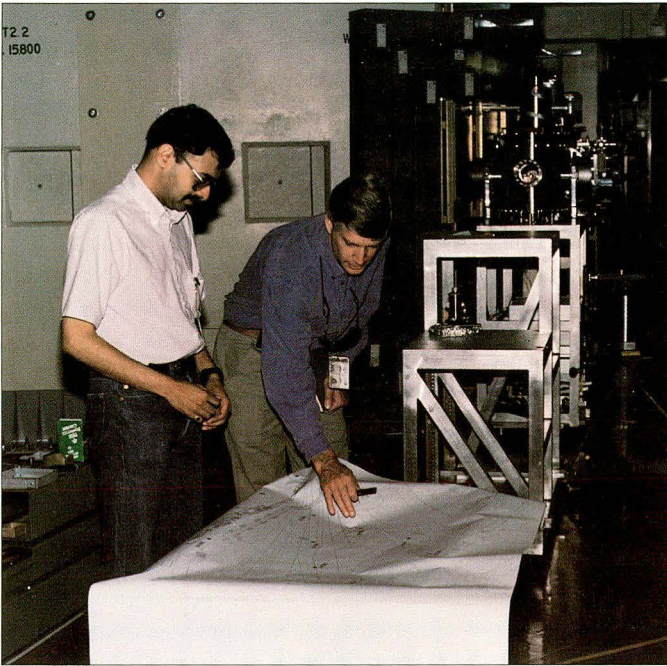

Ray Thatcher (right), head of the ALS Beamlines Operation Section, provides advice on equipment installation to Beamline 8.0 research team member Mahesh Samant from IBM.

Assistance with the logistics of research is provided by operations coordinators who are part of the ALS Operations Group. During storage ring operation, an operations coordinator is available at on the experiment floor all times to help solve users' problems and ensure compliance with safety regulations. The operations coordinators can resolve questions regarding floor-space allocation, housekeeping, and shipping and receiving. They also coordinate the services provided by the ALS support groups, which include electricians, crane operators, and electronics, mechanical, and UHV technicians.

The other side of the operations coordinator's job is ensuring compliance with all applicable environmental, health, and safety regulations. In this capacity they are responsible for inspecting and keying-on new beamlines or beamlines that have been shut down for

any length of time or for modifications. The operations coordinators also make sure that the proper documentation is posted adjacent to each beamline, that users have received all the training required for their experiments, and that hazardous materials are handled properly. They are also available to answer any questions that may arise concerning safety-related equipment such shielding, interlocks, and personnel protection shutters.

Community Outreach

Two workshops were held during the year as part of the ALS' mission to identify and explore new scientific opportunities for synchrotron light. Approximately 40 scientists and engineers participated in an informal workshop in April to discuss the production and use of elliptically polarized radiation at the ALS, and soft x-ray interferometry was the topic of a workshop held in June. The well attended annual ALS Users' Association Meeting in October also provided the opportunity to learn about the unique scientific opportunities offered by the ALS. See "Special Events" for a summary of the workshops and the annual meeting.

Users' Executive Committee

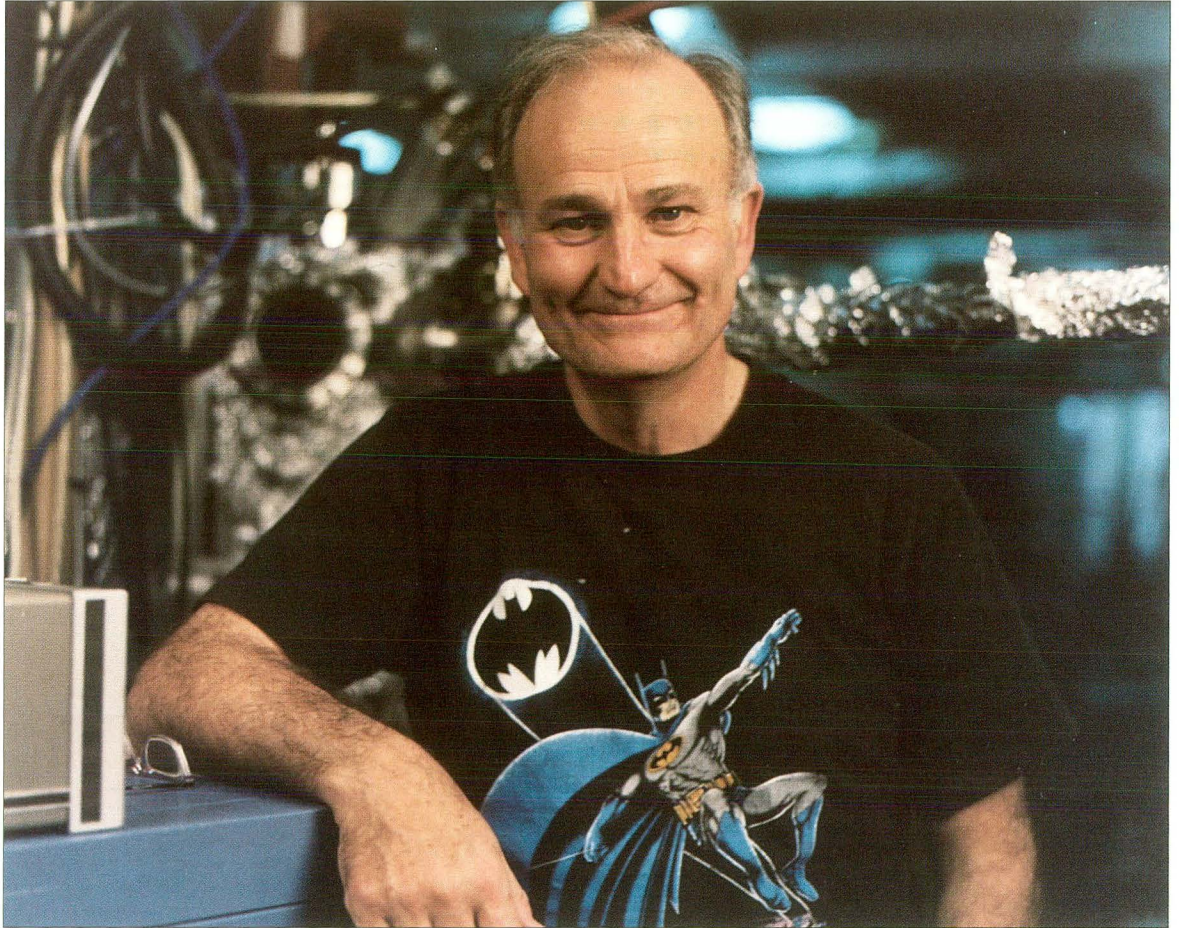

David L. Ederer, Chair Users' Executive Committee

I have many special memories of my year as chair of the ALS Users' Executive Committee. It began with the first beam successfully injected and ramped to full energy in the storage ring, and finished with the team at our endstation achieving their first results. Oh yes, in between there was the realization of 400-mA beam in the storage ring, as well as the users' meeting and dedication ceremony. Exciting times indeed! These moments come not by chance, but as the result of a large number of people working well together. I take this opportunity to express the thanks of all the users to the ALS team for their dedication and untiring efforts to bring the facility to successful operation and complete the initial set of user beamlines.

The dedication gave us all the opportunity to bask with pleasure at a job well done. But after all the accolades, there was work to be done! The first light had been delivered to a user beamline on October 4, and our Beamline 8 collaboration team was fervently working toward getting our first results. We weren't alone, our frantic pace of activity was being replicated on each and every other beamline as the promise of seeing "something exciting" with ALS light spurred everyone on.

Every day of progress on a beamline brings new questions and challenges to solve. Where are the utilities located? Has the software been installed? Did we order a filter for the mechanical pump? The list is almost endless, but it gets done step by step. Finally, we are ready. But where are the diffraction gratings? When will they be delivered? Well, if the grating isn't ready yet, we will use the output of the undulator directly! After all, it does have a narrow band width. Let's go! The undulator beam was turned on and the sample (a silicon substrate and a single layer of boron nitride molecules and an overcoat of carbon 50-Å thick) glowed with the fluorescence from the layer of boron nitride excited by the soft x rays.

What did all this mean? We had discovered a technique to study atoms at the interface between layers of material and answer questions about how the atoms are bonded: Are they corrosion sites? Is the interface conducting or insulating? With new materials in constant demand, the answers to questions like these provide important input toward the development of new technology. Of course, we owe the success of our initial experiments to many people, and Beamline 8 is only a microcosm of all the other beamlines—whose research teams will deliver their own exciting results as the future unfolds.

I am also pleased to report that there has been significant progress during the past year on a number of “quality of life” issues affecting ALS users. The streamlined “one-stop-shopping” sign-in and safety training process is operating efficiently, a clean-assembly laboratory and machine shop are ready for use, and several parking places have been reserved for ALS visitors. Office space is being made available to users, and plans for additional services are underway.

In closing, I encourage current and potential users of the ALS to take an active role in the development of its scientific program. It is up to us to make use of the opportunities and challenges that the ALS presents and help realize the full potential of the facility. The pace of events and accomplishments during 1993 has been truly remarkable—let it continue!

David L. Ederer, 1993 Chair
ALS Users’ Executive Committee

The Users' Executive Committee

The Users' Executive Committee (UEC) is an elected body comprising 11 members with staggered terms of three years. During 1993, the UEC made important contributions to planning for ALS operations, defining space requirements for user offices and laboratories, and devising the user safety program.

ALS Users' Executive Committee, 1993

C. Denise Caldwell, University of Central Florida
Thomas A. Callcott, University of Tennessee
George Castro, IBM Almaden Research Center
Stephen P. Cramer, University of California at Davis
Norman Edelstein, Lawrence Berkeley Laboratory
David L. Ederer, Tulane University (chair)
Piero A. Pianetta, Stanford Synchrotron Radiation Laboratory
(past chair)
Linda S. Powers, Utah State University
James G. Tobin, Lawrence Livermore National Laboratory
Brian P. Tonner, University of Wisconsin at Milwaukee and
Synchrotron Radiation Center, University of Wisconsin at Madison
Michael G. White, Brookhaven National Laboratory (vice-chair)

ALS User's Executive Committee, 1994

Harald Ade, North Carolina State University
Nora Berrah, Western Michigan University
Jeffrey Bokor, University of California at Berkeley
C. Denise Caldwell, University of Central Florida
Thomas A. Callcott, University of Tennessee (vice-chair)
George Castro, IBM Almaden Research Center
Norman Edelstein, Lawrence Berkeley Laboratory
David L. Ederer, Tulane University (past chair)
Linda S. Powers, Utah State University
James G. Tobin, Lawrence Livermore National Laboratory
Brian P. Tonner, University of Wisconsin at Milwaukee and
Synchrotron Radiation Center, University of Wisconsin at Madison
Michael G. White, Brookhaven National Laboratory (chair)

Industrial Outreach

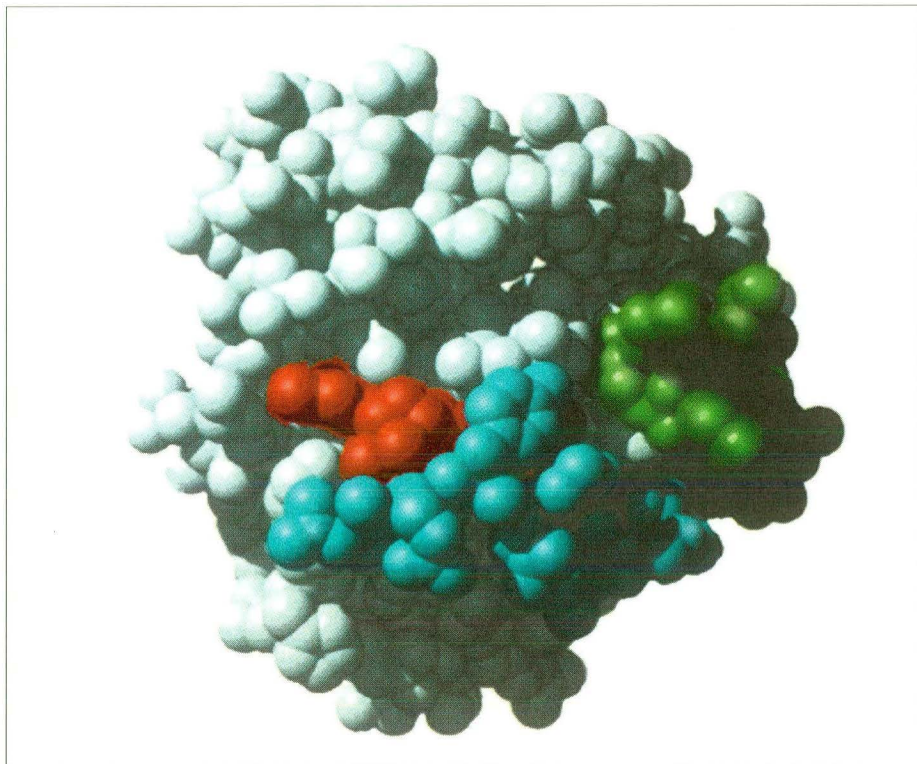

Computer-generated images of the structural backbone of the *ras* protein, a molecule which plays an important role in regulating cell growth in humans. The images are based on information gathered by a research team led by Professor Sung-Hou Kim using synchrotron-based x-ray crystallography. Professor Kim is director of LBL's Structural Biology Division and a co-developer of the proposed ALS macromolecular crystallography facility which will serve academic and industrial users.

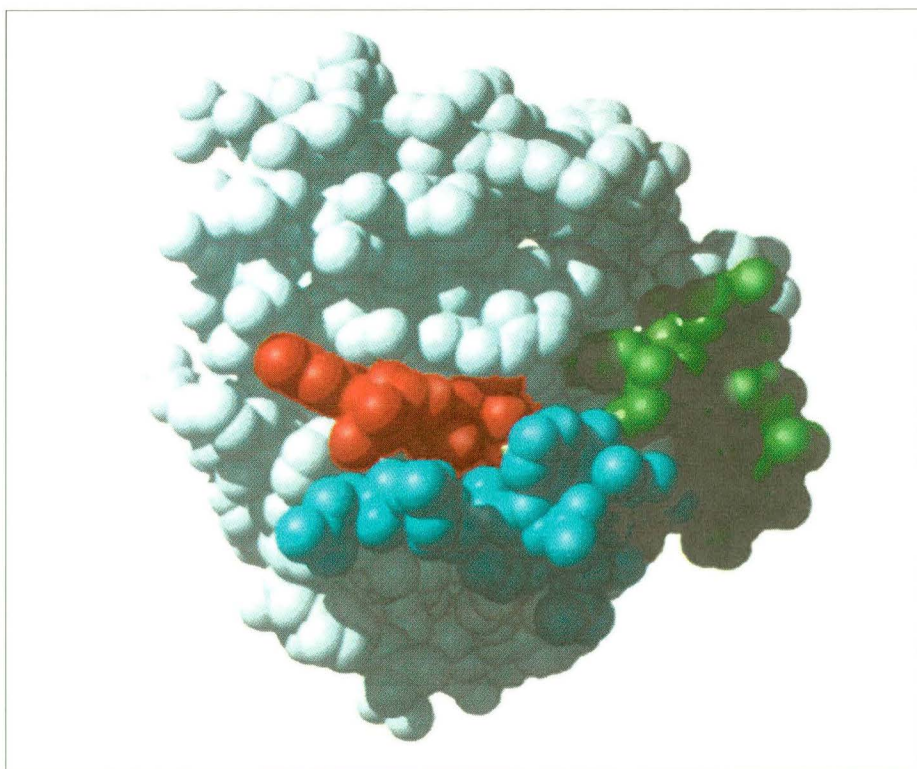

A significant role of the ALS as a national user facility is to build productive relationships with the private sector to develop the commercial potential of new technologies. We envision a broad spectrum of industrial applications for the ALS, with commercial activities accounting for an appreciable fraction of the facility's usage in the future. As such, we are developing a framework and strategy for industrial use of the ALS which is aimed at providing our industrial partners with the scientific and technological information and assistance they need to take advantage of the unique capabilities of this facility.

In the near term, the main growth areas for industrial collaborations are expected to be x-ray crystallography, microfabrication, nanoscopic compositional analysis, and x-ray spectroscopy. Our industrial outreach activities in these areas have already begun to bear significant fruit. We have formed several informal working groups with companies who are interested in using the ALS as part of their product research and development program, and we expect several of these interactions to develop into collaborative research projects in 1994.

Macromolecular Crystallography

A major focus of our industrial outreach effort has been in the area of x-ray crystallography, which is the premier technique for determining the atomic structure of biological macromolecules such as proteins (including DNA and RNA) and viruses. X-ray crystallography has made accurate 3-D modeling of such molecules possible for the first time, revolutionizing biochemical research. For pharmaceutical companies, this quantum leap in analytical capabilities has transformed a process of trial-and-error testing into a science of structure-based drug design.

This revolution in biochemical research and development has created a significant increase in the demand for state-of-the-art x-ray crystallography facilities—facilities the ALS is well suited to provide. So far, efforts to promote this use of the ALS have concentrated on defining the needs of prospective users and planning facilities to meet those needs. A draft White Paper, outlining plans for a user-friendly, high-throughput x-ray crystallography facility at the ALS, was distributed to the representatives of more than twenty commercial biotechnology and pharmaceutical firms and to nearly forty researchers at universities and national laboratories.

The document has won widespread approval within this group of organizations, and the Department of Energy (DOE) has requested a detailed proposal for the facility. Recognized as a key component in the ALS' scientific and industrial research program, the project has already received \$500,000 from the University of California through

LBL Director Charles Shank to start the construction of the insertion device for the beamline, and \$200,000 for FY 1994 from the Department of Energy's Office of Health and Environmental Research (OHER). Also proceeding in parallel is the design and construction of a high-power, curved-crystal monochromator, one of the key components of the beamline, using \$300,000 received from OHER.

The Macromolecular Crystallography Facility will provide highly-automated instrumentation to streamline such processes as crystal changing and alignment, detector calibration, and the storage, transfer, and analysis of experimental data. Users of the facility will also have access to the Structural Biology Support Facilities, a project that has been approved by the DOE for construction at the ALS beginning in FY 1994 at a cost of \$7.9 million and due for completion in FY 1996. The support facility, occupying 11,100 gross square feet near the protein-crystallography experimental stations, will provide computers for data analysis and laboratories for the preparation and characterization of samples.

Microfabrication

Micromachining features the use of x-ray lithography to produce mechanical and electromechanical devices and components of near-microscopic scale. Until recently, most of these tiny devices were made by surface micromachining, conventional lithography combined with thin-film deposition or etching. Our activities are concentrating

on the use of the new technique, deep-etch x-ray lithography, to produce more practical 3-D "high-aspect ratio" microscopic machines known as MEMS (for micro-electro-mechanical systems), which are very tall in relation to their length or width. These microstructures include micro-sensors, microactuators, and

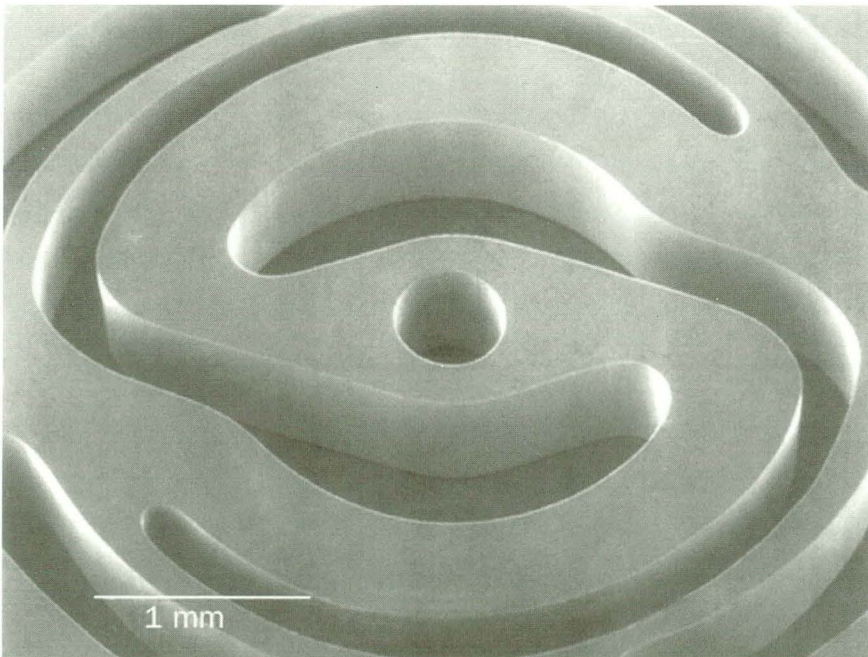

This microstructure, fabricated at the ALS by deep-etch x-ray lithography, could be used in the manufacture of thermal sensing units for automobile engines. The high precision of the lithography process enables complex structures like this to be manufactured with submicron accuracy.

micro-flow-control devices that find applications in fields ranging from automotive technology to bioengineering. Microstructures are considered by many to be the most promising new technology to appear on the high-tech horizon since the integrated circuit. Today's market for such devices is estimated at \$500 million, with the potential to exceed \$8 billion by the year 2000.

Several initiatives were launched in 1993 to help establish the ALS as a prime research and production facility for this burgeoning market. The first of these was the formation of a Bay Area MEMS consortium, whose initial membership includes LBL, other noncommercial research institutions, and a number of industrial firms that are enthusiastic about the commercial potential of MEMS. The consortium aims to promote MEMS research and investment within the greater San Francisco Bay area.

To promote active collaborations between the scientific and industrial communities interested in micromachining, the Technology Transfer Department and Center for X-Ray Optics at LBL organized a workshop on high-aspect-ratio MEMS in August 1993. One significant result of the meeting was the formation of the first Participating Research Team (PRT) dedicated to MEMS development. Its members include LBL's Technology Transfer Department and Center for X-Ray Optics (CXRO), the Jet Propulsion Laboratory, Lawrence Livermore National Laboratory, and Sandia National Laboratory in California. The group produced the first deep-etch x-ray lithography demonstration structures in late 1993, and has begun construction of an endstation on the CXRO beamline 10.3 for x-ray lithography. The endstation is scheduled to begin operation in August 1994.

The third, and perhaps most important, accomplishment for 1993 was reaching a cooperative agreement with four other facilities to provide a "duplicative infrastructure" for industrial users of the ALS' microfabrication facility. The participants are Lawrence Berkeley Laboratory (Advanced Light Source and Center for X-Ray Optics), the University of Wisconsin (Synchrotron Radiation Center), and Louisiana State University (Center for Advanced Microstructures and Devices) with Louisiana Technical University (Institute for Micro-manufacturing).

The facilities agreed to adopt common standards for the critical tools and processes required for microfabrication so industrial users will have at least one interchangeable second source. Further, the facilities will coordinate their operation schedules to ensure industrial availability for critical manufacturing runs.



Participants at the signing ceremony for the Memorandum of Understanding to develop common standards for microfabrication were Brian Kincaid (ALS Director), Glen Dahlbacka (LBL Technology Transfer Office), David Huber (University of Wisconsin), Brian Tonner (University of Wisconsin), and Volker Saile (Louisiana State University).

X-Ray Spectroscopy

We have also received considerable interest for industrial use of the ALS in the areas of materials, interface, and surface science. One such application is the use of microscopy for surface chemical analysis (see sidebar). The ALS offers the ability to use zone plate microscopes in combination with the techniques of near-edge x-ray absorption fine structure (NEXAFS) (also known as x-ray absorption near-edge structure (XANES)) and electron spectroscopy for chemical analysis (ESCA) to provide chemical information with a spatial resolution of greater than 300 \AA , a vast improvement over the 20 \mu m resolution achieved using conventional micro-ESCA.

NEXAFS can yield information on such items as chemical binding and bond symmetry and gives a unique chemical fingerprint of a particular chemical species. One potential use of the techniques is for a greater understanding of the nucleation and formation of voids in metal tracks on integrated circuits, and how the voids move along the tracks and aggregate with other voids eventually causing track failure (a process known as electro-migration).

Surface Chemical Analysis

Near-edge x-ray absorption fine structure (NEXAFS), also known as x-ray absorption near-edge structure (XANES), is becoming increasingly useful for the structural analysis of materials. This figure shows the extended x-ray absorption fine structure (EXAFS) region above an x-ray absorption edge and the NEXAFS region near the edge. NEXAFS permits a unique look at the atomic and electronic structure of a substance and allows scientists to tune in on a given constituent atom in a material to examine its local structural environment and chemical bonding with neighboring atoms.

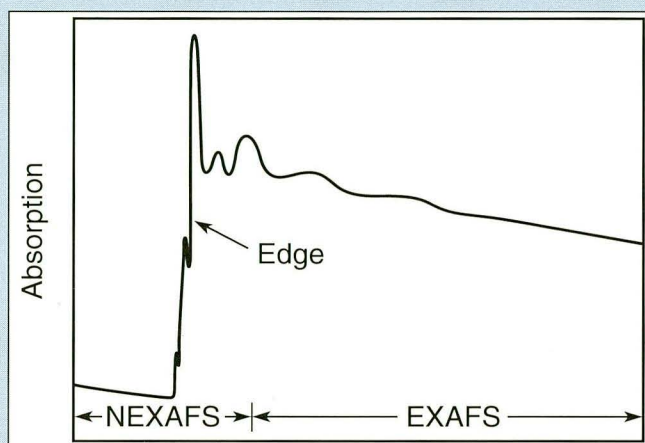

Electron spectroscopy for chemical analysis (ESCA) is one of the most direct spectroscopic tools for investigating in detail the electronic structure of solid, liquid, and gaseous matter and for probing the chemical state of

atoms in different environments. It is particularly useful for probing surfaces, whether clean, covered with adsorbed species, or coated with thin films. Electrons ejected from a sample after absorption of x-ray radiation are analyzed for their kinetic energies, which can be related to the binding energies of the electrons in the sample.

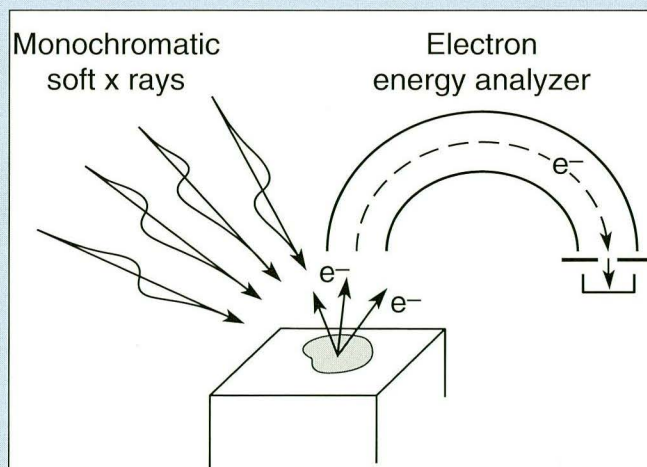

Accelerator Operations



The control room operators oversee the entire process of injecting, accelerating, and storing the electrons in the ring.

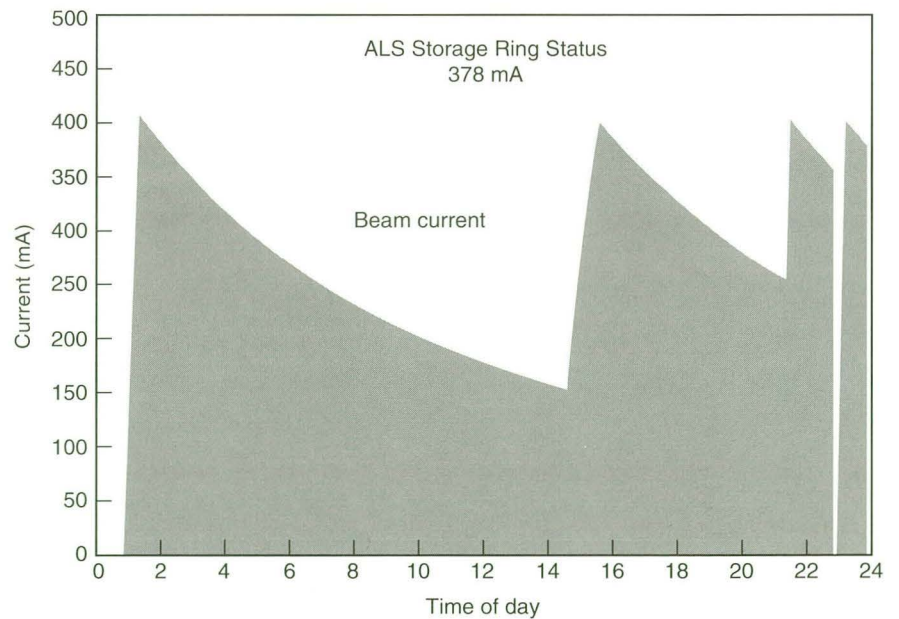

An example of the high level of performance and long beam lifetime achieved by the ALS by the end of 1993.

One of the biggest success stories for the ALS in 1993 was the rapid commissioning and outstanding performance of the accelerator systems and storage ring. The leap from first electrons into the ring to meeting all project baseline requirements was made in a little over two months, the first light was delivered to user experiments in October, and an enviable level of performance was achieved by year's end. We had shown that we could provide single-bunch, few-bunch, and multibunch operation on demand, and provide beam to users on a reliable schedule within promised parameters. The speed with which the Accelerator Systems Group led by Alan Jackson met our primary performance goals validated our overall design, and set a new standard in the accelerator community.

Commissioning Progress

The extremely eventful and successful commissioning of the ALS was launched on January 15 when electrons were first injected into the storage ring. After guiding the electron beam around the ring for the first time on January 19, the commissioning team quickly reached its short-range goal of 50–200 turns without the radio frequency (rf) power system working. By February 10, the team was routinely able to produce 1.5mA of coasting electron beam over more than 250 turns without using the steering magnets—a tribute to the design, construction, and alignment of the ring.

ALS Storage Ring Parameters

Operating energy	
Nominal	1.5 GeV
Minimum	1.0 GeV
Maximum	1.9 GeV
Natural emittance	3.6 nm•rad
RF frequency	500 MHz
Emittance ratio (ϵ_y/ϵ_x)	$\cong 5\%$
Horizontal beam size at symmetry	$\cong 0.20$ mm
Vertical beam size	$\cong 0.03$ mm
Beam current	
Multibunch mode	400 mA
Single-bunch mode	20 mA
Filling pattern (multibunch mode)	320/328 bunches
Bunch spacing	2 ns
Beam lifetime* (multibunch mode)	14 hrs

* Beam lifetime defined as the time for the beam to decay from 400 mA to 147 mA.

ALS Storage Ring Lattice Structure

(Top) The ALS storage ring has 12 arc-shaped and 12 straight sections. (Middle) One superperiod of the ALS triple-bend achromat lattice. A compact structure is achieved by including vertically focusing gradients in the bend magnets (B), and by using a single quadrupole family (QFA) to control the dispersion function, a quadrupole doublet family (QF and QD) to match the betatron tunes, and two families of sextupoles (SF and SD) to correct the chromaticity. (Lower) Horizontal and vertical β functions and dispersion for one superperiod of the storage ring lattice.

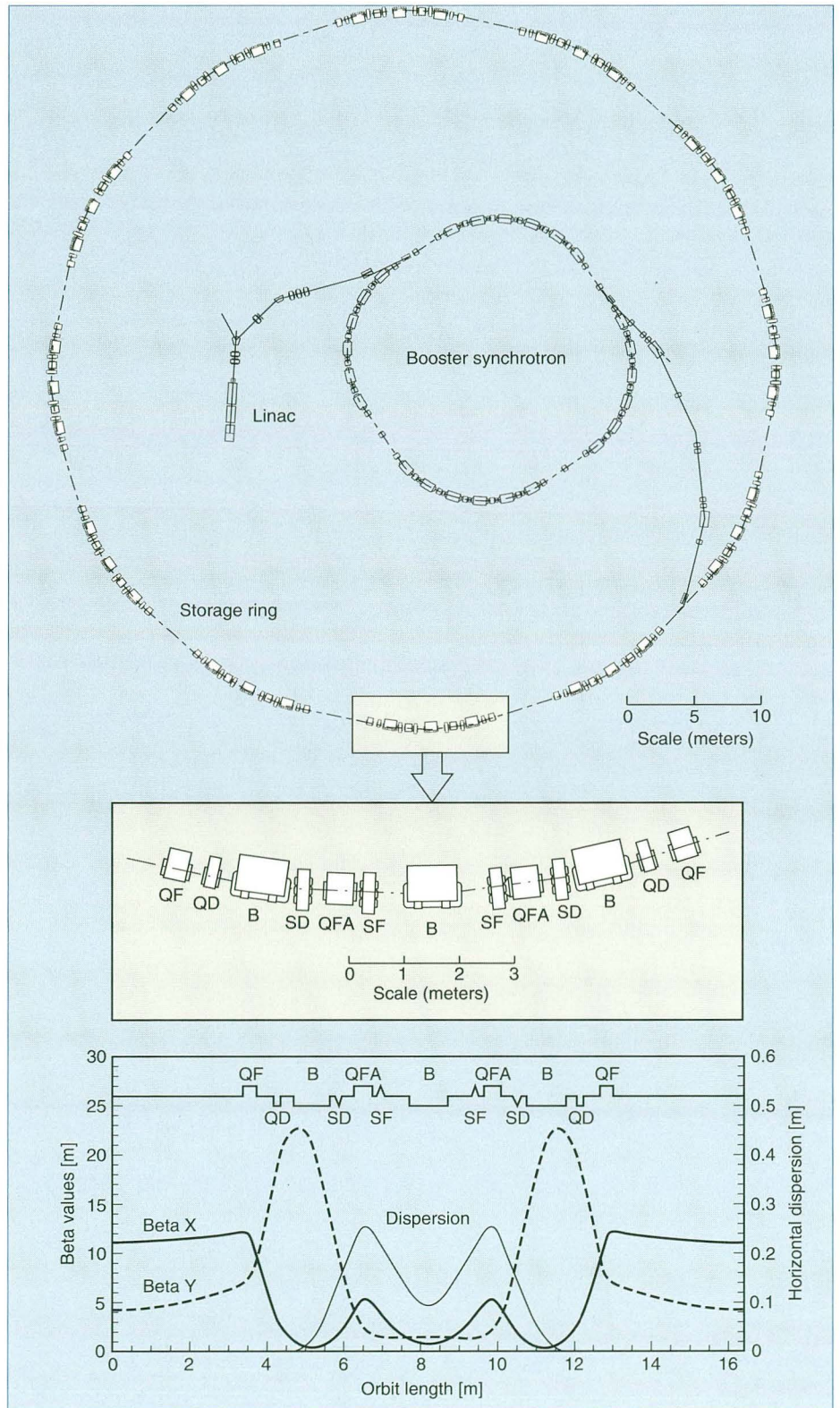

The many accelerator physics investigations made with this coasting beam gave us confidence in the model of the storage ring that is embodied in the control system. The next step was to begin using the rf system to replenish the energy lost by synchrotron radiation. On March 16, rf power was applied and the beam began to accumulate in the ring with only minimal tuning of the storage-ring parameters. The beam current was a mere 6 mA, with a lifetime of only 5 minutes, but clearly all systems were functioning (Figure 1). Eight days later, the technical baseline requirement of 50 mA was met and exceeded, and on April 9 the project goal of 400 mA was reached. By the end of April the storage ring had exceeded its beam-current specifications, reaching 407 mA in multibunch mode and 27 mA in single-bunch mode, and we could routinely achieve 1.5-hour beam lifetimes at 100 mA. Although a great deal of work remained in order to achieve a long-lasting, low-emittance beam so that good service to users could be provided, the essential performance requirements had been demonstrated.

We made great strides in understanding the storage ring during this initial period of operations. With no means of directly measuring beam emittance, we relied on careful measurements of the Twiss parameters to provide an estimate of emittance, which appeared to be

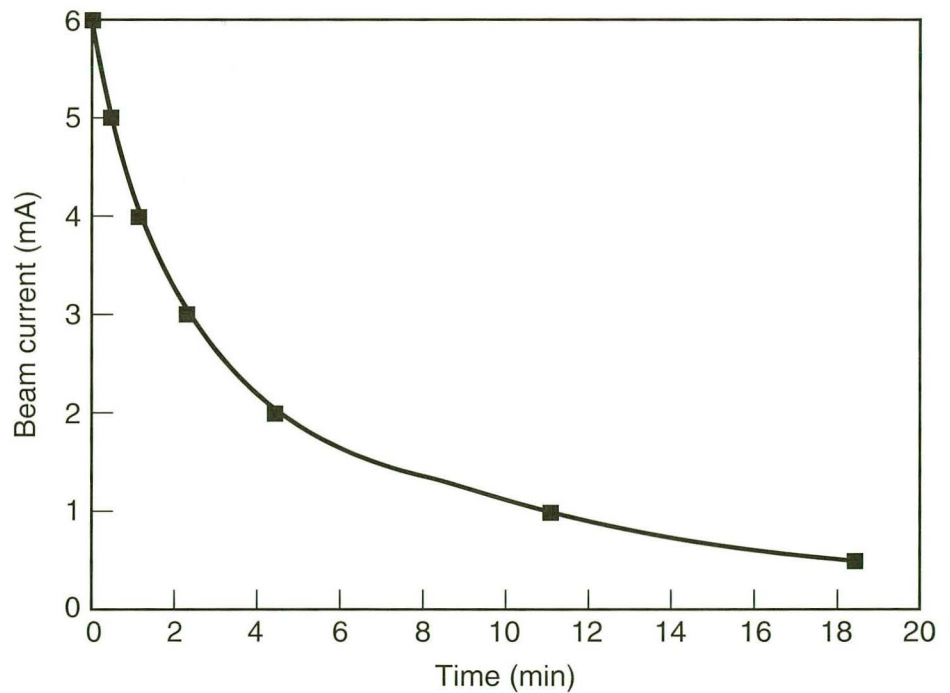

Figure 1. ALS storage ring current on the first day of beam accumulation, March 16, 1993.

well within the predicted range. These measurements also enabled us to:

- Correct chromaticity (i.e., chromatic aberrations in the focusing effects of the quadrupole magnets).
- Correct the vertical orbit to within 0.5 mm rms of the nominal path, having started with peak-to-peak variations of 12 mm.
- Establish that coupling between horizontal and vertical betatron motion (i.e., horizontal and vertical beam oscillations) was less than 1% (Figure 2).

In May the accelerator was shut down to permit installation of two undulators and the front ends for the first five beamlines, and we took this opportunity to prepare for the fall's commissioning activities. The entire storage ring was baked (heated so that any remaining contaminants and adsorbed gases would be given off and pumped out) and every critical component in the ring was surveyed and realigned. The result is the magnets are now aligned within 100 μm rms, 50 μm better than the specification called for. Two important new diagnostic

systems were installed during this period as well. The first of these was a system of transverse kickers for resonantly driving betatron motions. The addition of these kickers enabled us to measure the betatron frequencies directly for the first time. The second was the diagnostic beamline designed to provide an image of the electron beam. Using data recorded by the beamline, we will be able to derive beam intensity profiles and measure the beam's cross-section.

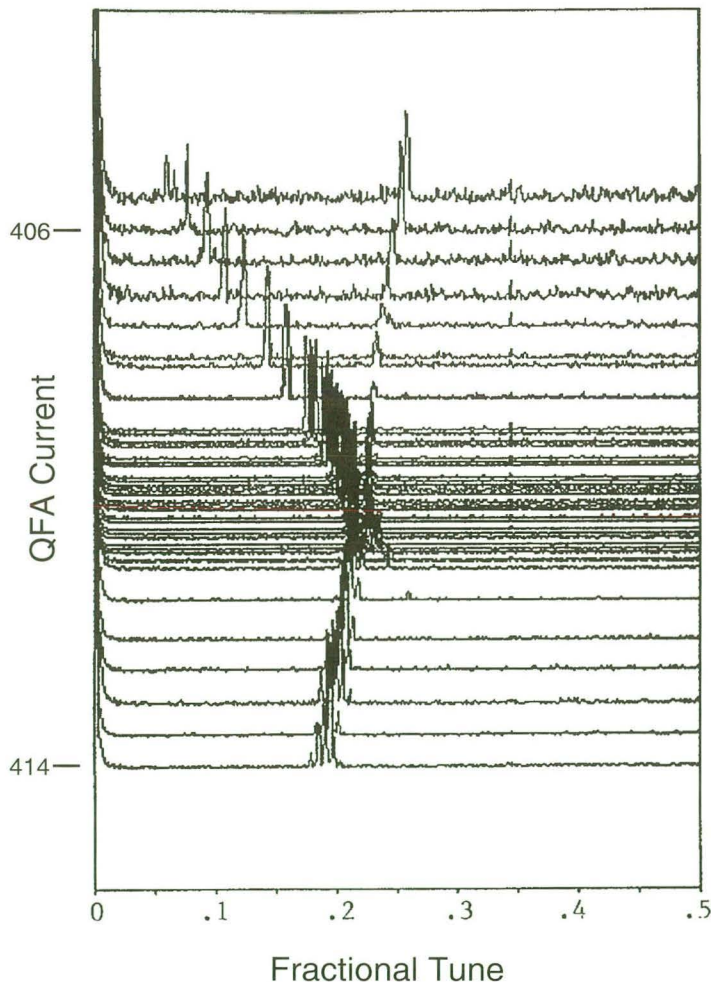

Figure 2. The variation of horizontal and vertical betatron frequencies as a function of the current supplied to the QFA family of focusing quadrupole magnets. The frequencies were measured through Fourier analysis of turn-by-turn data collected by the 96 beam position monitors in the storage ring. The point near the center of the graph where the two traces nearly touch marks a "coupling resonance," a frequency at which energy is exchanged between the horizontal and vertical betatron motions. The distance between the two traces at this frequency provides a measurement of coupling strength. Coupling is of concern to both accelerator physicists and users because it tends to increase the vertical emittance (decreasing brightness).

Major Advances in Performance

Bringing the accelerators back on-line took less than two hours when operations resumed at the end of August: a testimonial to (among other things) the accuracy and long-term stability of the power supplies. After some beam conditioning of the vacuum system and commissioning of the ancillary titanium sublimation pumps, high-current running was reestablished. Within a few days we measured a beam lifetime of 12 hours at a current of 100 mA.

The hardware installed during the shutdown enabled us to determine emittance more accurately than before and to measure beam stability for the first time, and the results obtained in both areas were better than predicted. In addition, we continued our efforts to refine the storage ring's performance, improving orbit correction and beam lifetimes significantly. We also began implementing a strategy designed to reduce the performance-limiting instabilities that were noted during multibunch-mode operation. Several areas of progress are worthy of mention:

Measuring beam emittance. The horizontal and vertical emittances were measured using the pattern of undulator radiation in Beamline 7.0. These measurements gave an upper limit of 5 nm rad for horizontal emittance, very close to the theoretical value of 3.5 nm, and an upper limit of 0.2 nm rad for vertical emittance. With these measurements in hand, we were able to fine-tune the storage ring to optimize its performance.

Measuring beam stability. Special photon-beam-position monitors were developed that can sense undulator beam motion with 1- μ m sensitivity in the hope of tracking electron beam motion with equal accuracy (Figure 3). These monitors have not yet been fully commissioned, but preliminary results are very encouraging because they indicate that feedback systems may not be required to meet the extremely tight tolerances for beam motion.

Correcting the beam's orbit. A new closed-orbit correction algorithm, based on the measured response functions of the corrector magnets, made it possible to reduce orbital displacement to 0.3 mm rms in both planes. Attempts to reduce this displacement further will be pursued in 1994.

Improving beam lifetimes. By the end of the year, we had achieved an extremely high level of reliability and performance. We were routinely able to fill the storage ring to a current of 400 mA, which decayed to 150 mA over a period of 8 hours. One factor that helped beam lifetimes was the improvement in vacuum base pressure to

ALS-designed photon-beam-position monitor (PBPM). In the center are two copper blades that project into the path of the undulator photon beam. The photoemission of electrons from the surfaces of the blades provide signal currents to a detection system. The difference in the signal current readings from the two surfaces can be used to detect movement of the beam path as small as $1\ \mu\text{m}$. Information from the PBPMs can be used by a feedback system to adjust the steering magnets in the storage ring to stabilize the electron beam. The symmetry of the detector design about the line of the beam ensures that the position signal is insensitive to heating of the internal detector components by the photon beam.

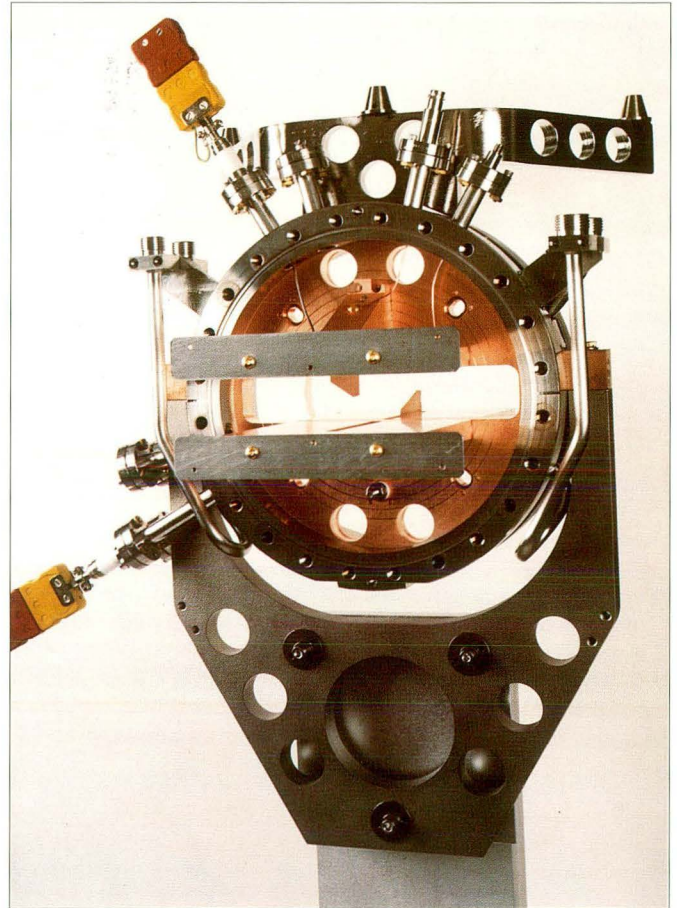
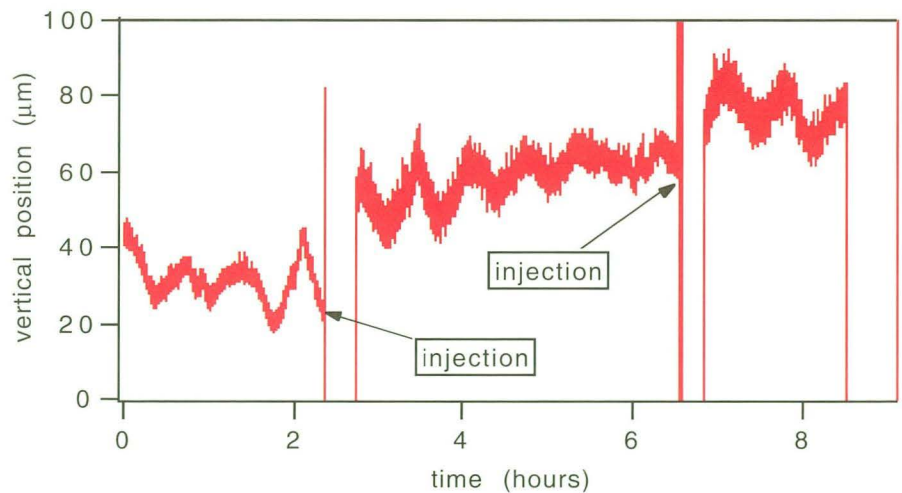

Figure 3. Data derived from two PBPMs in Beamline 7.0 shortly after they were commissioned with no feedback stabilization system operational. The graph indicates clearly that there is an acoustic beam jitter of $< 5\ \mu\text{m}$ rms, as shown by the thickness of the trace; that the drift during each fill is about $20\ \mu\text{m}$, and that there is a periodic variation in beam position. These measurements of stability show that the ALS without feedback is more stable than the best of the other modern storage rings by at least a factor of 10. The periodic variation, which has a time constant of 40 minutes, has been observed on all PBPM; its source is probably thermal and is under investigation.



levels in the range of 10^{-10} torr. This improvement resulted from the bakeout of the entire storage ring over the summer shutdown and the commissioning of powerful titanium sublimation pumps. Improvements in the system that measures rf output also helped by giving the operators the confidence to employ higher rf power levels, which resulted in longer beam lifetimes.

Reducing multibunch-mode instability. As operations proceeded, we detected very fast longitudinal beam oscillations during multibunch-mode operation which cause significant increases in photon beam sizes in the bend magnet beamlines. We are currently collaborating with Stanford Linear Accelerator Center and Lawrence Berkeley Laboratory's Center for Beam Physics to design longitudinal kickers to combat this motion. They are scheduled to be installed during the May 1994 shutdown.

The fruits of this intensive work in commissioning the storage ring and machine physics development were beginning to be seen at the end of 1993. On October 4, the ALS delivered the first light to a user experiment—the fluorescence microprobe on Beamline 10.3. Soon thereafter, using a minute 0.5 mA of electron beam, the undulator radiation was characterized on Beamline 7.0. These events marked the start of the experimental program at the ALS, which presents many new challenges for accelerator physics. For example, one issue we will address early in 1994 is the “dance of the undulators.” As the gaps of the undulators are opened or closed to tune the photon energies of the beamlines, the variations in the residual dipole fields perturb the electron orbit. Correction of these kinds of behaviors will form the foundation of the next level of investigations as we push toward the ultimate performance of the ALS.

The commissioning of the first four ALS beamlines during the latter half of 1993 meant the beamline control system received its first operational test, which it passed with flying colors. This accomplishment represents an outstanding level of effort by members of the ALS Control Systems and Electrical Engineering Groups, who faced the task of developing and implementing a system to cover a wide range of applications ranging from radiation safety to user-directed control of beamline equipment.

The ALS beamlines control system consists of three subsystems: one for radiation safety, the second for equipment protection, and the third for controlling beamline mirrors, monochromators, and other instruments involved in performing experiments. Each of the subsystems constitutes a layer in the system's three-layer architecture. The radiation-safety system is at the bottom and has the highest functional priority, the equipment-protection system is the middle layer and has second priority, and the instrument-control system is at the top with the lowest functional priority. All beamlines, whether built by the ALS or by participating research teams, will incorporate the radiation-safety subsystem design, developed by the ALS Electrical Engineering Group. The beamlines built or adapted by the ALS staff will also incorporate the equipment-protection and instrument-control subsystem designs, although beamline developers from any organization can opt to use these designs for their ALS beamlines.

The radiation safety system (RSS) is responsible for monitoring radiation levels, initiating audible and visual alarms when radiation levels exceed predetermined levels, and triggering interlocks to shut off the source of radiation if the radiation reaches or exceeds preset levels (thus preventing exposure of personnel to radiation). Each radiation monitor in the RSS system is fail-safe, and will immediately shut down the accelerator if the monitor malfunctions or loses power. The equipment-protection system (EPS) protects beamline components from damage caused by vacuum failure or excessive heating. Its primary function is to close the appropriate isolation valve in the event of a vacuum fault downstream from that valve, and close the photon shutter in the beamline's front end to protect the valve. Like the RSS, these EPS responses are automatic.

Instrument-Control System

Of the three subsystems, the instrument-control system (ICS) is the one with which beamline users interact firsthand. The ICS provides interfaces for controlling a number of beamline functions, and provides a wealth of status information concerning beamline instruments, the undulator's gap-control mechanisms, the electron beam, and the photon beam. For example, the ICS enables the users of the ALS-designed undulator Beamline 7.0 to:

- Control the undulator gap setting (including feedback on the status of gap-change requests).
- Control the width of the horizontal beam defining aperture in the beamline front end.
- Control a horizontal knife-edge that can be used in conjunction with the horizontal beam defining aperture to obtain beam profile measurements.

- Set the vertical condensing mirror to a specific deflection angle and scan the mirror through its entire deflection range.
- Rotate the monochromator grating to a particular position to obtain a specific output wavelength, either with or without automatic repositioning of the exit slit.
- Rotate the monochromator grating through its entire range, either with or without simultaneous automatic repositioning of the exit slit.
- Control the exit slit's position (independent of moving the grating).
- Control the deflection angles of the refocusing mirrors downstream from the exit slit.

On other beamlines, the ICS may include controls for horizontal focusing mirrors, movable monochromator entrance slits, and "diverter" mirrors that direct the photon beam into any of two or more branch lines.

All of these functions are available to the user via menu-driven graphical-user-interface (GUI) screens that are displayed on the UNIX-based workstations adjacent to the beamlines. In addition, most of the same functions are available to endstation computers over a serial RS-232 link, allowing users to employ almost any type of computer at their endstation. As noted above, beamline developers have the option of implementing the control system of their choice, including the ICS designed by the ALS control systems group.



Members of the ALS Controls Group test one of the applications they developed for beamline instrument control.

Insertion Devices

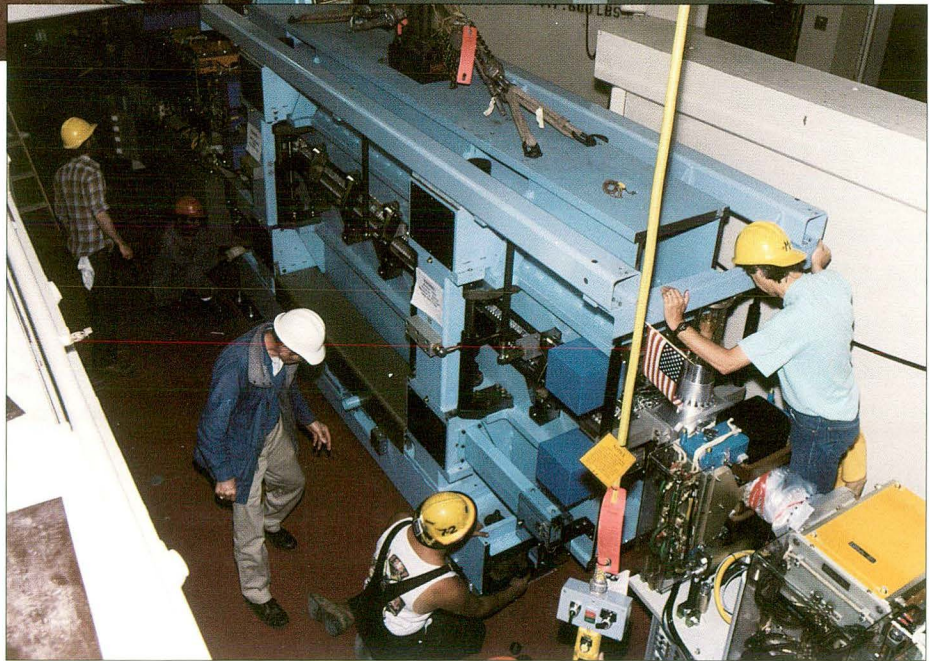
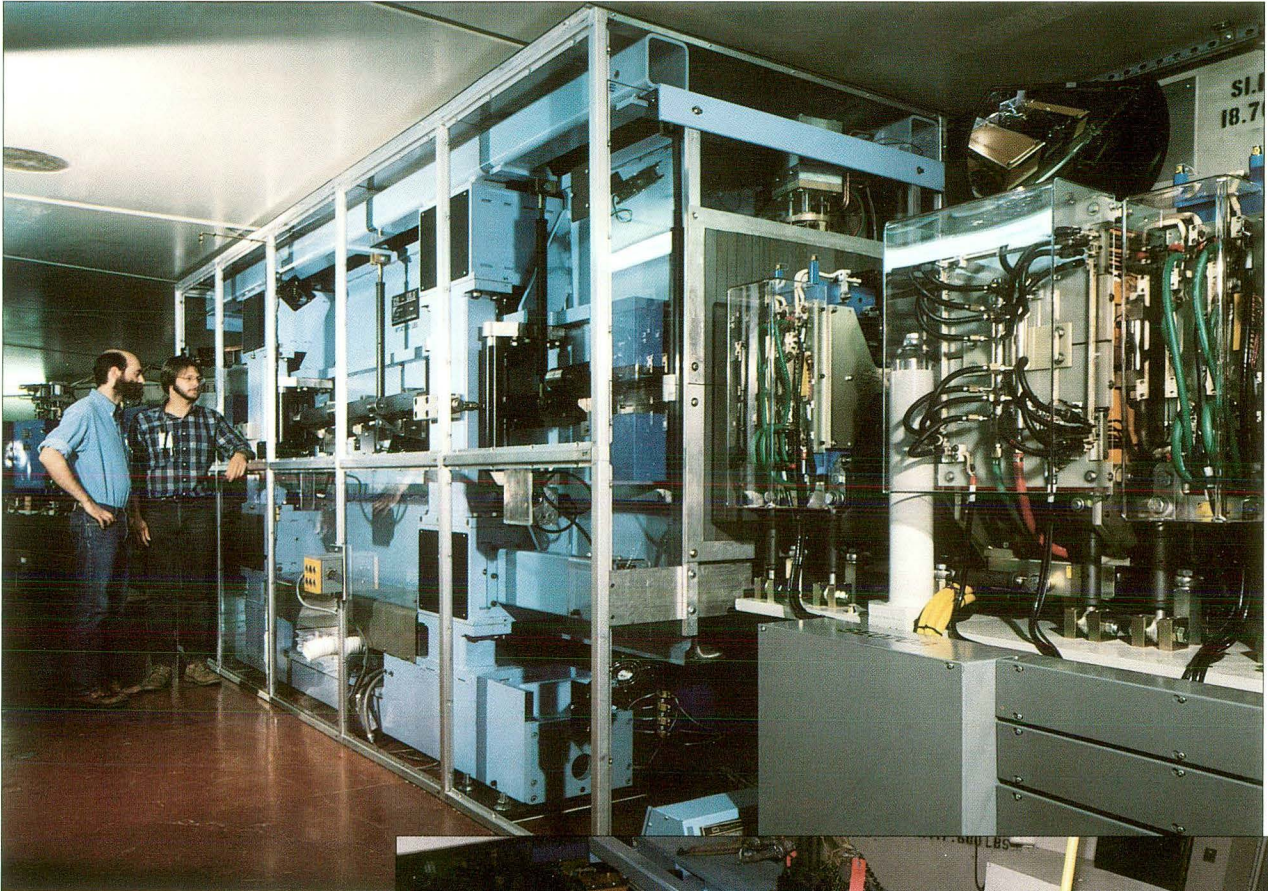

Two US undulators like this one (shown during and after installation) were installed and commissioned in 1993. They are the world's brightest sources of soft x rays.

The first two ALS undulators were installed and commissioned in 1993, becoming the world's brightest soft x-ray sources for scientific research. The light from these undulators signaled the dawn of a new generation of synchrotrons—optimized to produce light from insertion devices generating radiation with dramatically enhanced spectral properties.

The ALS has specified the major parameters for six of the ten insertion devices that the storage ring can accommodate. As mentioned above, two of these devices (5-cm-period undulators) were installed during a planned shutdown in May and were providing light to user experiments by the end of the year. The remaining four consist of a 8-cm-period undulator to be installed in June 1994, a 10-cm-period undulator, and two wiggler insertion devices (See Table 2 and Figures 4 and 5).

Design Strategy Proves Effective

The basic approach in designing the initial set of undulators was to base mechanical and magnetic tolerances on spectral output goals, and our magnetic measurements and subsequent photon beam measurements have validated this approach. One of the most stringent requirements for their performance was a degradation of no more than 30% in the output of the fifth harmonic, thus setting the maximum random magnetic field error requirements at 0.25% for the 5-cm-period undulators (U5s) and 0.35% for the 8-cm-period undulator (U8). Random errors are primarily due to the tolerances to which the permanent-magnet blocks can be constructed, deviations from ideal field structure, and tolerances to which the period structures can be fabricated and assembled together. The actual random field error values were measured to be 0.23% for the U5s and 0.20% for the U8, exceeding the design goals.

Our measurements did reveal one deviation from the desired performance parameters. In January we measured the lateral nonuniformity of integrated fields within the beam aperture to be higher than the allowable value. However, by late February we were ready to install a correction scheme that proved highly effective. Our solution was to install transverse arrays of small permanent magnets at the ends of each undulator, both above and below the midplane. The size, position, and orientation of each of these trim magnets can be altered, enabling us to correct both vertical and horizontal integrated field errors by more than an order of magnitude. The solution to this problem represented a significant advance in the design of insertion devices, and the speed with which it was accomplished reflected the engineering team's commitment to ensuring the quality of the devices' ultimate performance.

Device	Beamline	Status (at 1.5 GeV)	Energy Range	Period Length	Number of Periods	Operating Gap Range	Peak Effective Field Range
U5 Undulator	8.0	Operational	130–1900 eV	5.0 cm	89	2.3–4.5 cm	.46–.10 T
U5 Undulator ¹	7.0	Operational	130–1900 eV	5.0 cm	89	2.3–4.5 cm	.46–.10 T
U8 Undulator ²	9.0	Completed: to be installed in 5/94	18–1200 eV	8.0 cm	55	2.5–8.3 cm	.80–.07 T
U10 Undulator ³	12.0	Design and construction in progress	5–950 eV	10.0 cm	43	2.4–11.6 cm	.98–.05 T
EW20 Elliptical Wiggler	11.0	Design in progress	50 eV–10 keV	20.0 cm	14	6.4–1.4 cm	.04–2.0 T
W16 Wiggler	5.0	Design in progress	5 keV–13 keV	16.0 cm	19	18.0–1.4 cm	.03–2.0 T

¹ In 1995, we will install a vacuum chamber that will allow a minimum gap of 1.4 cm. This reduction in the minimum gap will increase the maximum effective field strength to .85 T, extending the lower limit of the energy range to 50 eV.
² To be moved to beamline 12.0 in 1995.
³ To be moved to beamline 9.0 in 1995.

Table 2. ALS Insertion Devices for 1993–1996.

The rigorous commissioning process for the undulators also revealed excellent mechanical performance. Dynamic tests of the undulator drive systems revealed excellent uniformity of motion. In 500 random moves of the magnetic structure gap, the variation was no greater than $\pm 5 \mu\text{m}$, which is excellent for a structure weighing nearly 25 tons. We also conducted tests on one of the U5s to determine its optimum taper (i.e., the variation in the gap along the length of the device). Spectral measurements made while varying the taper of the device showed that the optimum taper is less than $25 \mu\text{m}$ from the initial gap parallelism setting. This represents a variation of less than 1 part in 20,000 over the undulator's 5-meter length. Also worthy of mention is the performance of the vacuum chambers in the undulators. With full current in the storage ring (400 mA), the vacuum in these chambers routinely measures 2×10^{-10} torr, a factor of 5 lower than required. The payoff for users is that they will have substantially less *Bremsstrahlung* (unwanted high-energy radiation) at their experimental stations than if we had merely met the original requirements.

Figure 4. Brightness as a function of photon energy for the insertion devices that will be operational by the end of 1995. The brightness values plotted here reflect a 1.5-GeV, 400-mA electron beam. The undulator plots show the curves for the first, third, and fifth harmonics. Although the 20-cm-period elliptical wiggler (EW20) is capable of providing circularly polarized photons, the curve shown here indicates its brightness when it is not doing so (i.e., when its electromagnetically generated horizontal field is switched off). In this mode, the elliptical wiggler behaves like a conventional wiggler.

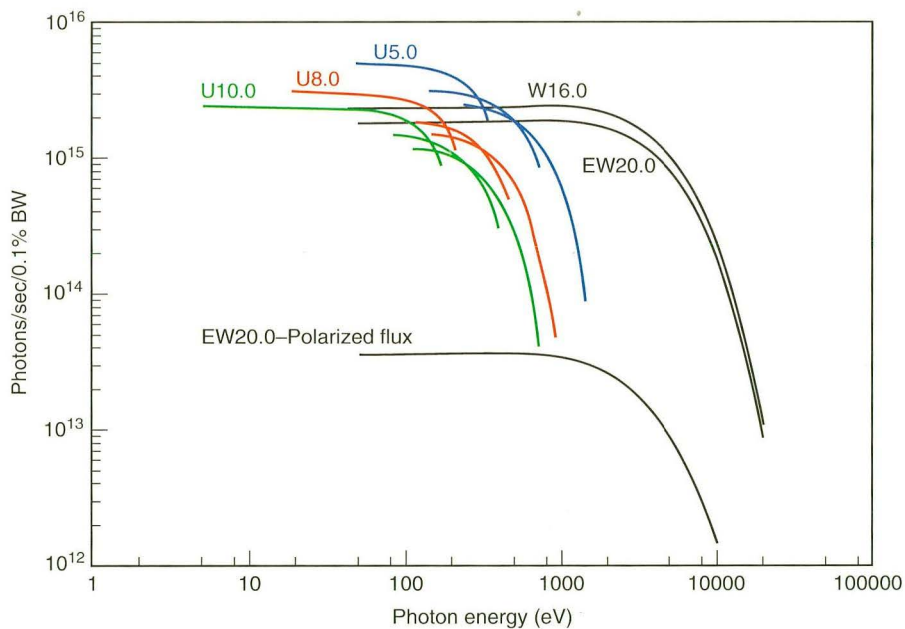
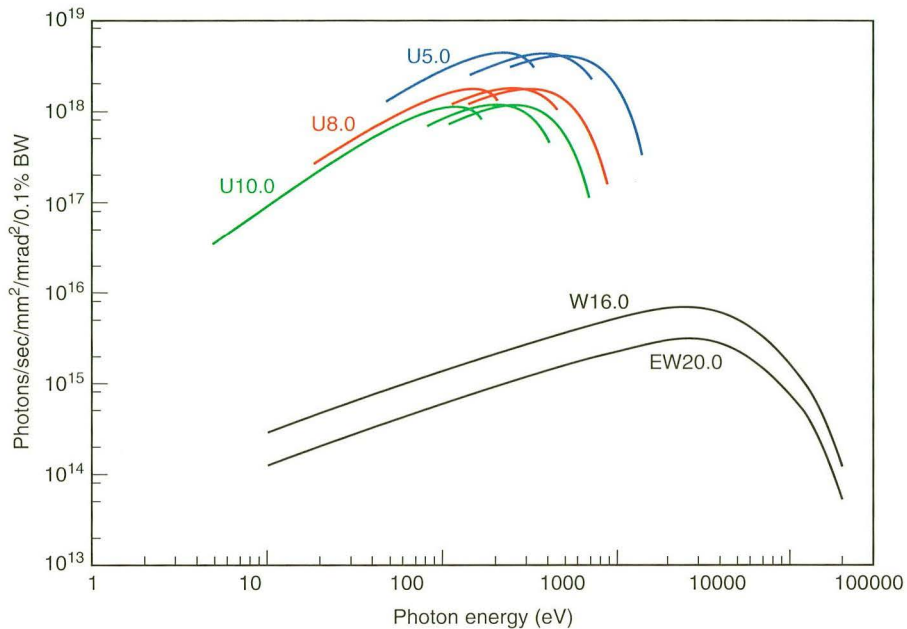
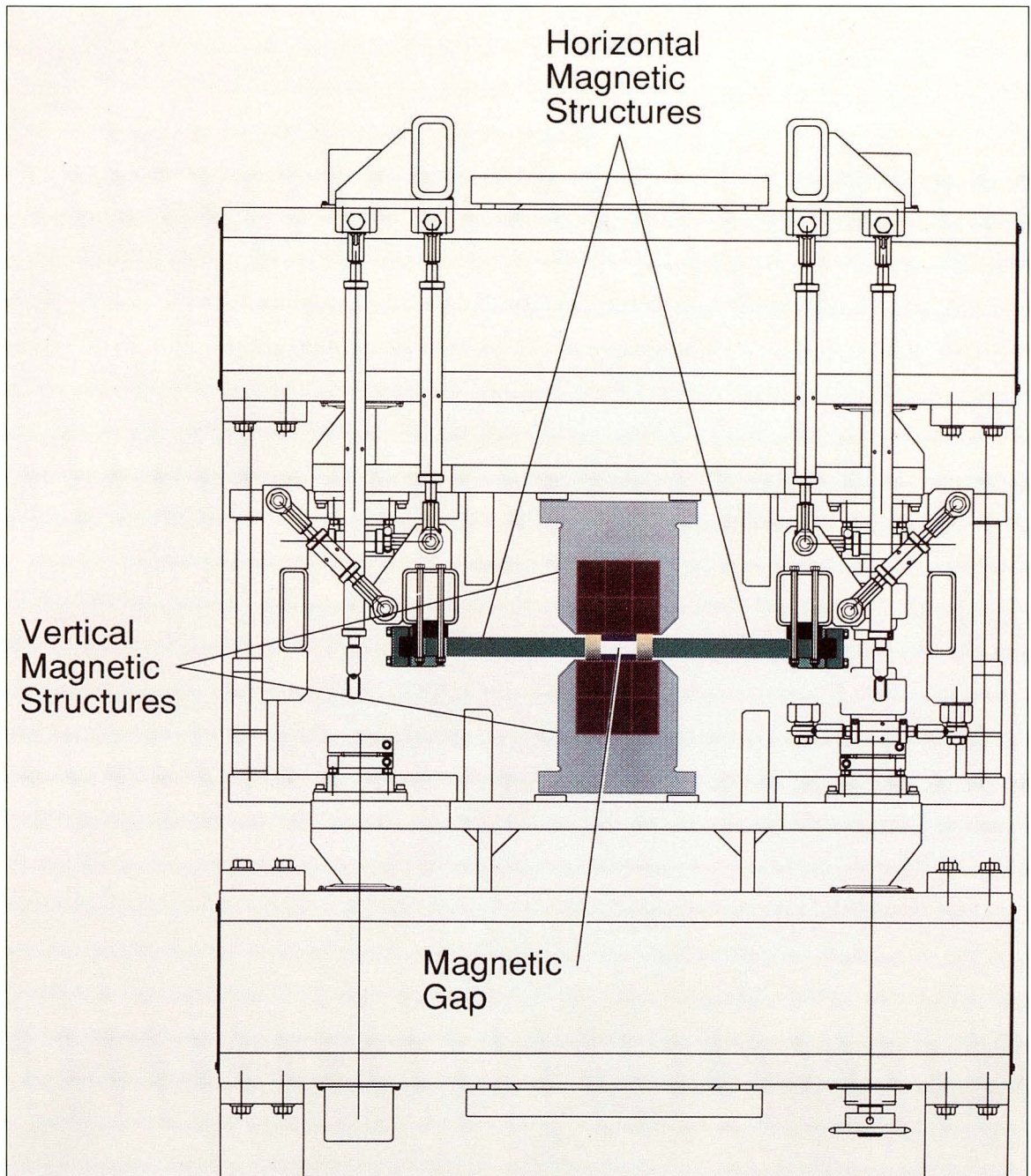

Figure 5. Photon flux as a function of photon energy for the insertion devices that will be operational by the end of 1995. The flux values plotted here are for a 1.5-GeV, 400-mA electron beam with a horizontal aperture of ± 2.5 mrad. The undulator plots show the curves for the first, third, and fifth harmonics. Note that the elliptical wiggler (EW20) is represented twice on this graph. The EW20 curve just below the W16 curve shows the flux produced by the elliptical wiggler when the electromagnets that produce the horizontal field are switched off. In this mode, EW20 behaves like a conventional wiggler. The lower EW20 curve shows the circularly polarized flux produced by the elliptical wiggler when its horizontal field is active (creating a circularly polarized photon beam) and when the vertical and horizontal fields are set to optimize the unavoidable tradeoff between flux and degree of circular polarization.

Ongoing Efforts

Development of additional insertion devices proceeded while the first undulators were being installed and commissioned. We continued our magnetic measurement tests on the completed U8 and initiated the design for a 10-cm-period undulator (U10) which will be installed in mid-1995. Work was also started on a special small-gap vacuum chamber for the Beamline 7.0 U5 undulator. After this chamber is installed in early 1995, it will be possible to close the undulator's gap to a minimum of 1.4 cm. At this gap setting, the maximum effective field strength will be increased to .85 T, extending the device's energy range to a lower limit of 50 eV.

Conceptual work also progressed on a 16-cm-period wiggler (W16) for the proposed protein crystallography beamline, and an elliptical wiggler designed to produce circularly polarized light. The W16 wiggler will be configured to provide radiation at the 1-Å wavelength which is ideal for macromolecular crystallography studies. The elliptical wiggler (EW20) will have 14 periods, each 20 cm in length, and will generate high-intensity radiation in the range of 50 eV to 13 keV. In this crossed-field device, the periodic vertical magnetic field will be produced by the same sort of hybrid (permanent magnet-vanadium permendur) structure used in the other ALS insertion devices. At right angles to this hybrid structure will be an electromagnetic structure that generates a periodic horizontal field oscillating at up to 1 Hz. When installed in early 1996, EW20 will deliver on-axis circularly polarized light whose chiral orientation (i.e., right/left-handedness) changes with the oscillations in the horizontal field. We are currently developing custom software that will enable us to determine the spectral output of such crossed-field devices for calculated magnetic field values, with the goal of optimizing spectral output with respect to various operating parameters.



An end view of the general mechanical and magnetic structure of the elliptical wiggler being designed by the ALS. The device will produce circularly polarized radiation in the photon energy range of 50 eV to 10,000 eV. The horizontal magnetic structure is installed such that its peak field is 90° out of phase with the peak vertical field. In contrast to bend-magnet beamlines which produce circularly polarized x rays, the ALS elliptical-wiggler beamline will use the same optical elements and the identical optical path for the two polarizations, and will deliver higher flux. It will be possible to alternate from right- to left-circularly polarized radiation at a rate of approximately 1 Hz.

Experimental Systems

The optics challenges of the ALS have resulted in a series of technological innovations, many of them made in close collaboration with private industry. To date, the R&D 100-winning Long Trace Surface Profiler has been able to measure the surface slope error of optical components to better than $1 \mu\text{rad rms}$. With the help of these instruments, water-cooled metal optical components that are at least as good as the best glass components have been fabricated for the ALS. Surface microroughness figures of 2 \AA rms —five times better than previously achievable—have been obtained on 38-cm-long copper alloy mirrors coated with electroless nickel.

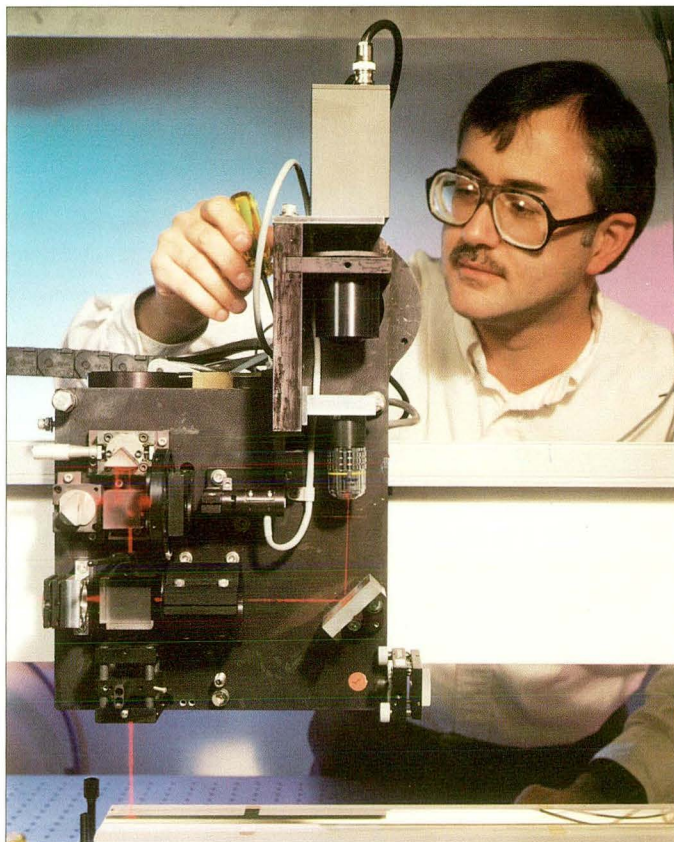

An ALS-designed transmission grating spectrometer was temporarily installed in Beamline 7.0 to characterize the photon beams from the 5-cm-period undulator.

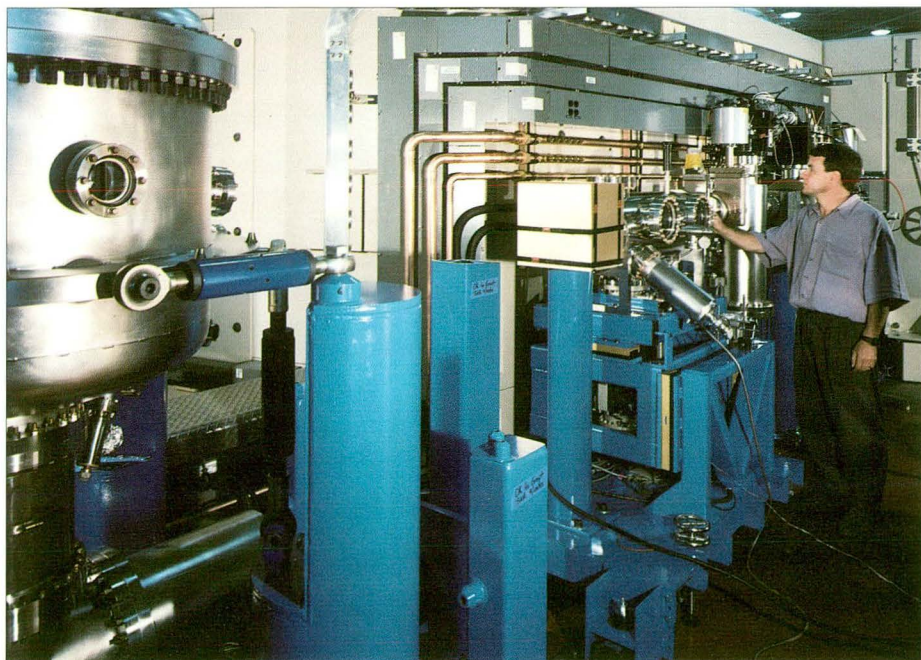

The design, fabrication, testing, and commissioning of beamline instrumentation and optical components for the start of user operations were a strong focus of ALS activity during 1993. A large part of this effort was shared by the Experimental Systems Group under the leadership of Howard Padmore, who concentrated on the installation and commissioning of the ALS-designed beamlines, the design and fabrication of the optical components for the beamlines, and the design and construction of a unique transmission grating spectrometer to characterize the light delivered by the 5-cm-period undulator installed in May. A few of the group's many accomplishments are highlighted below.

Characterizing Undulator Light

Beamline 7.0, scheduled for completion in January 1994, temporarily housed a special ALS-designed transmission grating spectrometer (TGS) in October to characterize the radiation from one of the first two undulators installed in the storage ring (the 5-cm-undulator in sector 7) and provide a confirmation of the undulator's performance. The spectrometer measures the absolute intensities and spectral linewidths of the undulator harmonics as well as the angular distribution of undulator radiation. The results of the measurements are then compared with radiation calculations, which include the measured magnetic field, emittance, and energy spread of the electron beam.

Measurements were performed at four undulator gaps for which the undulator magnetic field had previously been measured. Since Beamline 7.0 uses the central cone of the 1st, 3rd, and 5th harmonics of undulator radiation, the intensity and linewidth of these harmonics were used as a test standard for undulator performance. Angular distributions were

measured showing the central cone and the red-shifted radiation off axis, and the electron beam emittance at low current was determined from the angular distribution of the red-shifted fundamental.

Data from the TGS validated the theoretical predictions of the undulator's performance derived from detailed magnetic-field distribution measurements taken by the ALS Insertion Device Group before the undulator was installed. From the angular distribution of the red-shifted fundamental, the TGS measurements showed the ALS

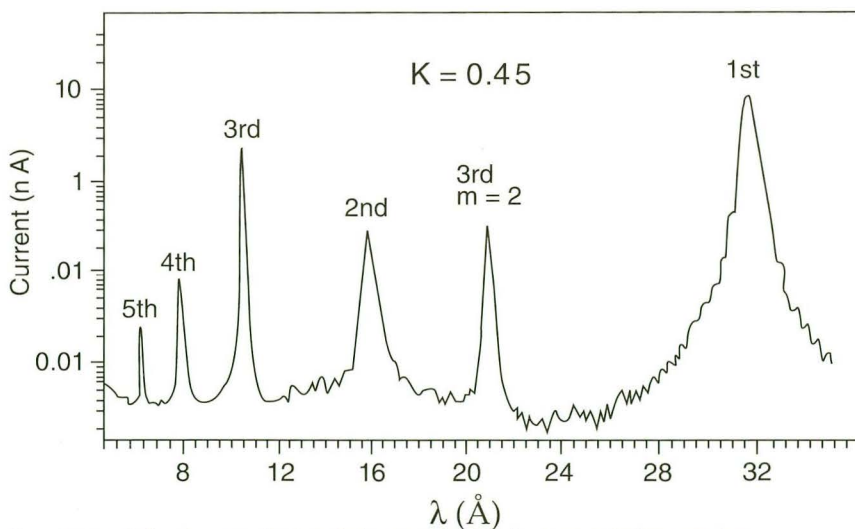

Spectrum of the 5-cm-period undulator taken by the transmission grating spectrometer showing the fundamental and harmonics at a value of $K = 0.45$.

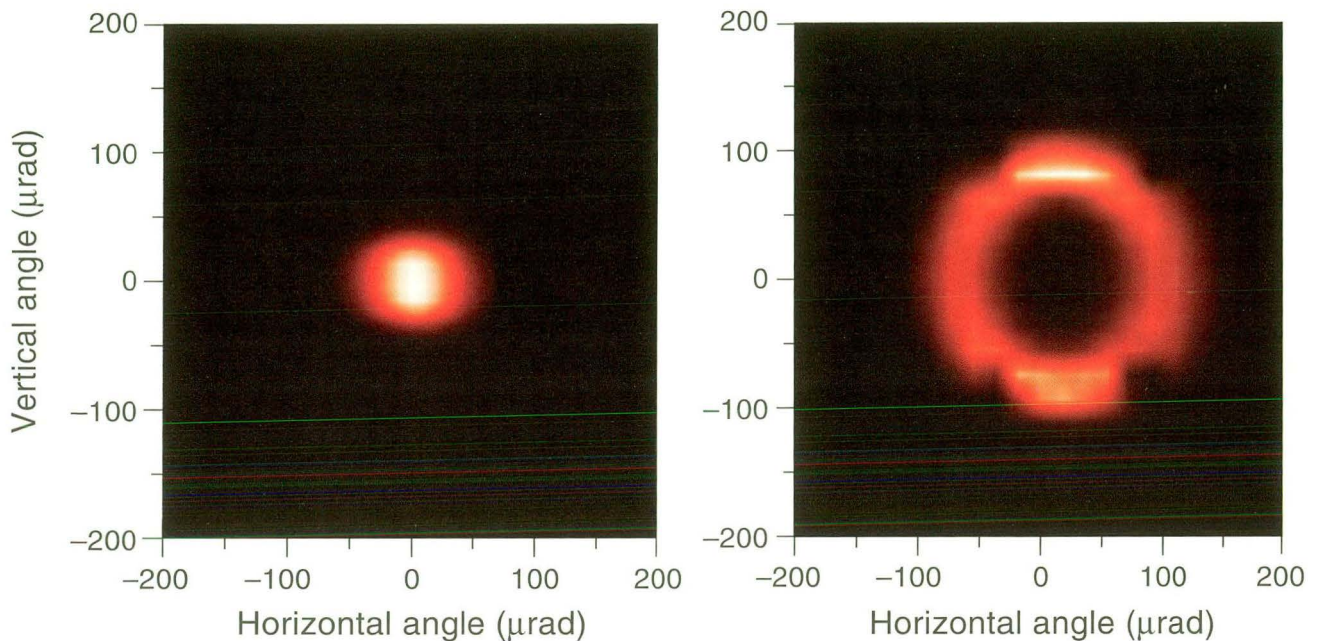

Angular distribution of the US undulator fundamental at $K = 0.45$ as measured by the transmission grating spectrometer. (Left) If the observation energy coincides with the energy of an odd undulator harmonic (395 eV), one observes a peak in intensity directed along the axis of the electron beam passing through the undulator. (Right) If the observation energy is decreased (374 eV), the emission cannot occur along the axis, but is distributed in a hollow cone of increasing angular width as the energy is decreased. In this image the cone is shadowed by the blades on the beamline's photon-beam-position monitor.

emittance at low current to be in agreement with its theoretical value. Other measurements revealed that the first harmonic had a nearly ideal lineshape, while the 5th harmonic was broadened by emittance and energy spread as expected.

The TGS was removed in December when the undulator measurements were complete, and the final components for Beamline 7.0 were installed in preparation for the commissioning of the beamline in early 1994 (see Beamlines 1994–1995 on page 48). Beamline 7.0 will be used for photoelectron diffraction, fluorescence spectroscopy, and photoelectron spectromicroscopy at photon energies from 80 eV to 1200 eV.

Design of Diagnostic Beamline Provides a Challenge

Obtaining an accurate image of the electron beam in the storage ring presented a unique challenge for the ALS. Since the source size given by the electron beam is extremely small, the ALS cannot use visible light, as other synchrotron facilities have, to produce an image of the electron beam in the storage ring as the diffraction limited source size would be too large. Instead it was necessary to develop a new type of diagnostic beamline that would use shorter wavelength soft x rays to image the electron beam.

The ALS diagnostic beamline (Beamline 3.1) is essentially a high-resolution x-ray imaging system that produces a 1:1 image of the bend magnet source located in sector 3 of the storage ring. Within the beamline, the x rays from the source are focused using two spherical mirrors positioned in a Kirkpatrick-Baez configuration. The mirrors direct the photon beam onto a single crystal scintillator screen where the x rays are converted into a visible light image of the source. The image is then focused onto a CCD camera by an ordinary microscope where it can then be viewed on a television monitor or digitally captured on a computer using a frame grabber. Operating at almost unity magnification, the optical system minimizes aberrations associated with spherical optics.

Image data is transmitted to the ALS control room, where operators can use it to optimize storage ring performance. Data from the beamline will be used by the ALS Accelerator Physics Group to study beam stability, measure vertical and horizontal beam sizes, and derive measurements of the emittance and coupling of the electron bunches in the storage ring. The beamline also will enable the accelerator physicists to study injection processes, as its special shielding allows it to be operated while the storage ring is being filled. The beamline is being commissioned and is not yet in routine operation.

Path of the synchrotron light through the optical components of the ALS diagnostic beamline.

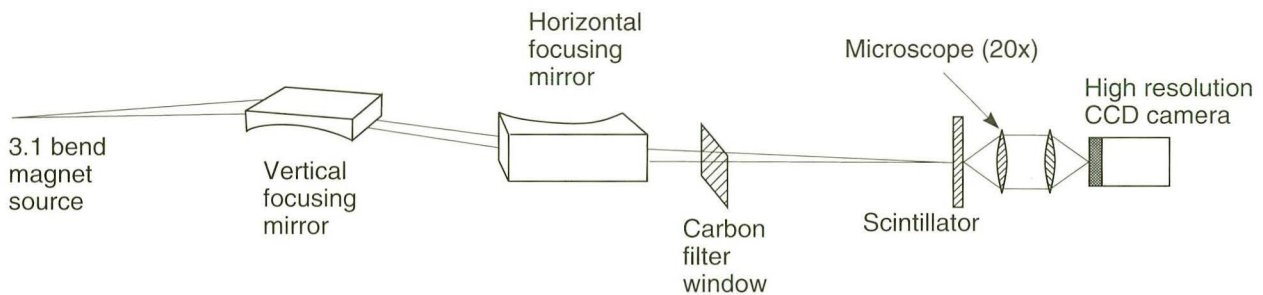

Innovations in Optics and Metrology

The design and fabrication of optical components for ALS beam lines present many challenges. The relay optics and monochromator components must achieve exceptionally tight tolerances to maintain the extreme brightness of the source through the beamline to the experiment, with the high heat load from the undulator and wiggler sources further complicating the design. To meet these challenges, the ALS has systematically improved the technology of grazing incidence optics in the critical areas of optical materials, fabrication, and metrology.

The ALS, working together with Rockwell International's Rocketdyne Division, has developed a new design and fabrication technique to produce mirrors that can reflect a practically distortion-free image under very high heat loads, thus preserving the brightness of the light being reflected by the mirror. Water-cooling channels just underneath the surface keep the mirror cool and stress-free despite the extreme heat load on the surface caused by the intensity of the x-ray beams hitting the surface.



The typical quality of optical components for use in this demanding field had been sub-optimal for many years. Our requirements are stringent (slope errors in the range of $1 \mu\text{rad}$, for example), so optical metrology plays a key role. To this end, the ALS project funded the construction of two long-trace profilers based on a surface-profiling instrument developed at Brookhaven National Laboratory. One of them is operating in the ALS Optical Metrology Laboratory, where it is housed in a cleanroom to avoid contamination of optical surfaces. The other is installed at Rocketdyne Corporation, a private company with which we have been cooperating to develop manufacturing techniques for water-cooled metal beamline optics. The design team included scientists and engineers from LBL, Brookhaven National Laboratory, Continental Optical Corporation, Baker Engineering, and Tucson Optical Research Corporation.

Another achievement of the ALS in the area of optics fabrication is the development of a new monolithic design for an adaptive-radius x-ray mirror. In earlier schemes, it had been common practice to use engineered "benders" to bend flat mirrors to make cylindrical x-ray mirrors.

Several clamps would be applied to the outside of the mirror, and when these were tightened the mirror would change its shape slightly. Unfortunately, such changes could not be controlled to the extremely tight tolerances required for modern x-ray applications.

In the new design, the entire bending mechanism of mirror, clamps, and motion devices is made from a single monolithic block of material. The bending motion is thus achieved with a single mechanism that includes both the mirror and the bender, and can be precisely controlled. This new design results in lower manufacturing costs, improved adjustability of the focusing process, and has the advantage of being able to use existing precision polishing methods. In particular the mirror can be prebent to a flat, polished as a flat, and then relaxed into a planned shape—a process called “stress polishing.”

These and other developments have opened a new era in the availability of high-quality grazing-incidence optical elements for synchrotron radiation. The significance of these multiyear, cooperative efforts, which benefit not only the ALS but our industrial partners and the synchrotron radiation community in general, was recognized with the Federal Laboratory Consortium’s Technology Transfer Award in 1992. This year the Long Trace Surface Profiler was further honored with the R&D 100 award, given by the magazine *Research and Development* to recognize the 100 most significant technical innovations of the year.

The dawning of first light in ALS beamlines came as a particular satisfaction to the Beamline Engineering Group, an aggregation of mechanical and electrical engineers, fabricators, and technicians formed to focus engineering expertise on the design, construction, installation, and ongoing support of ALS beamlines. Working closely with the personnel of the ALS Experimental Systems Group, the Beamline Engineering Group has developed the basic designs for ALS beamline front ends, beam-position monitors, mirrors, and monochromators.

The success of this collaborative team is reflected in the performance of all the beamline components they designed and constructed, but the magnitude of their achievement can perhaps best be appreciated by examining one of the more intricate components they fabricated for the ALS-designed undulator beamline—the monochromator entrance slit. The basic goal for this beamline was to deliver photons from the fundamental and the third and fifth harmonics of the undulator with minimum losses and with a spectral resolving power of up to 10^4 , a daunting challenge! At maximum resolution, the photon beam will be concentrated within a focal spot as small as $50\ \mu\text{m} \times 50\ \mu\text{m}$ on the sample.

The development of the design for the beamline's spherical grating monochromator entrance slit, which is subject to a very high peak power density from the focused undulator source, provides a good look at the engineering group's teamwork approach. The performance parameters for the monochromator meant that the width of the entrance slit had to be precisely controllable, because the size of the entrance slit's opening is a critical determinant of the spectral resolution achievable at the exit slit (i.e., how narrow the range of wavelengths selected by the exit slit can be). An entrance slit width of $10\ \mu\text{m}$ is optimal for most wavelengths, but an $8\text{-}\mu\text{m}$ slit provides better resolution for a narrow range of higher wavelengths. In addition, some users will want to open the entrance slit as wide as $100\ \mu\text{m}$, sacrificing optimal spectral resolution in order to maximize photon flux.

Based on these requirements, the initial entrance slit specifications called for a slit width that would be adjustable between a minimum of $5\ \mu\text{m}$ and a maximum of $200\ \mu\text{m}$. A further requirement was that the two slit blades should move as symmetrically as possible throughout their adjustment range. This meant that two blades must move equal distances (within tight tolerances) whenever adjusted, so that the slit's horizontal center line remained stationary as its width was changed. It was also critical to ensure that the slit blades would remain parallel (again, within narrow limits) throughout their adjustment range, so that the rectangular shape of the slit would not change.

To meet these stringent performance criteria, the engineering team designed a flexure assembly that transfers the actuation forces to the slit blades, allowing them to open and close. The two blades that actually define the slit opening are mounted securely on the flexure assembly, which deflects as the actuator is adjusted in or out. The resulting slit blade movement is almost perfectly symmetrical and parallel. The group made heavy use of 2-D and

3-D computer aided design (CAD) programs in the development of this mechanism, as they did in the design of the entire entrance slit assembly.

The designers also made innovative use of finite element analysis (FEA), a 2-D computer modeling technique widely used for the analysis of large-scale mechanical processes but not commonly applied to optical microstructures. The engineers employed FEA to obtain precise pictures of the thermal loading on the slit blades and the flexure assembly under various conditions. These analyses enabled them to optimize the heat transfer characteristics of these components so that heat would be carried toward the internal water-cooling channels on the opposite side of the assembly from the sensitive actuator. The end result of all the design and development work was a "state-of-the-art" entrance slit capable of meeting its performance requirements under any foreseeable conditions.

The entrance slit is just one of several beamline components and instruments designed and constructed by the ALS Beamline Engineering Group, but is an excellent demonstration of the team's high quality workmanship and ability to develop innovative solutions to challenging problems. The

excellence of performance delivered by Beamline 7.0, a true triumph of engineering, will provide a "living tribute" to the skills of the entire engineering team.

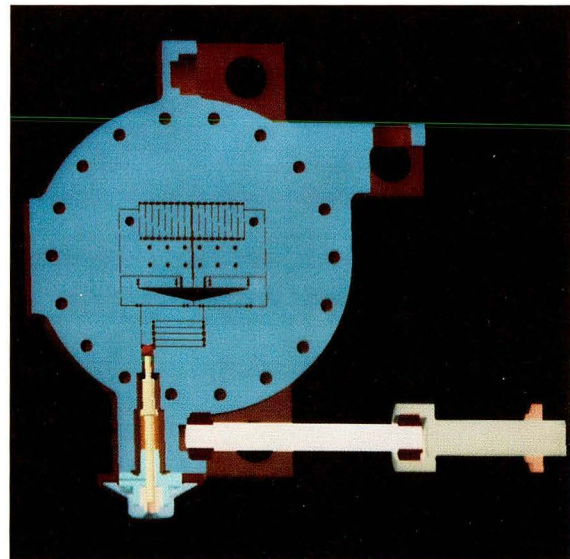
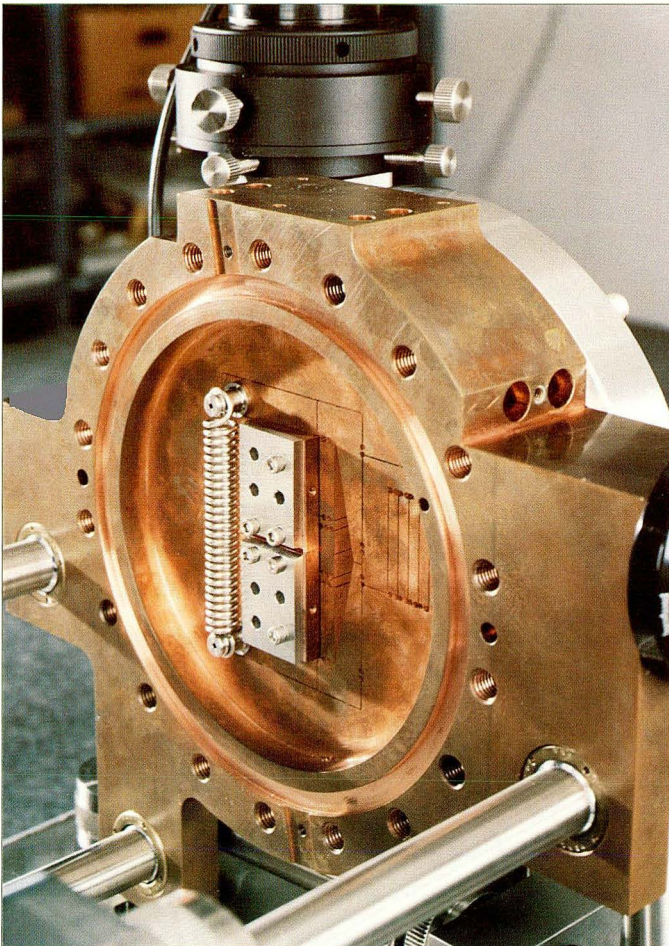

The design for the entrance slit for the Beamline 7.0 monochromator was one of the most demanding engineering challenges faced by the Beamline Engineering Group. The maximum power load of the photon beam on the slit is nearly 100 watts, thus the flexure assembly had to be designed to minimize thermal distortion of the slit mechanism due to heating by the beam. The computer-generated image shows the entrance slit flexure assembly, and the photo shows the instrument during fabrication.

Fluorescence X-Ray Microprobe

October 4 was an exciting day at the ALS as a bright orange glow from a phosphor-painted target signaled the start of user experiments. The target was placed in the experimental hutch of LBL's Center for X-Ray Optics fluorescence x-ray microprobe beamline, giving it the distinction of being the first operational beamline at the ALS. The beamline, which provides elemental analysis of a wide variety of samples in near-natural environments, is designed to achieve a spatial resolution approaching 1 μm using multilayer-coated mirrors in a Kirkpatrick-Baez configuration. Broad-band excitation of samples at photon energies from 6 to 10 keV, as well as white-light excitation, is possible.

The Beamline 10.3 microprobe quantitatively detects elements by means of the characteristic fluorescent x rays emitted by the irradiated sample. The

photon energy identifies the element and the intensity measures its quantity. At present, the elemental sensitivity of the microprobe reaches the femtogram (10^{-15} g) level for elements from potassium to zinc in the periodic table. Scanning the sample through the beam generates a two-dimensional map of the distributions of the detected elements. A major advantage of the x-ray microprobe is that the specimen does not have to be kept in vacuum or subjected to special contrast-enhancing preparation. The microprobe beamline participating research team (PRT) consists of members of LBL's Materials Sciences, Applied Sciences, Earth Sciences and Engineering Sciences divisions, as well as scientists from Oak Ridge National Laboratory and Lawrence Livermore National Laboratory.

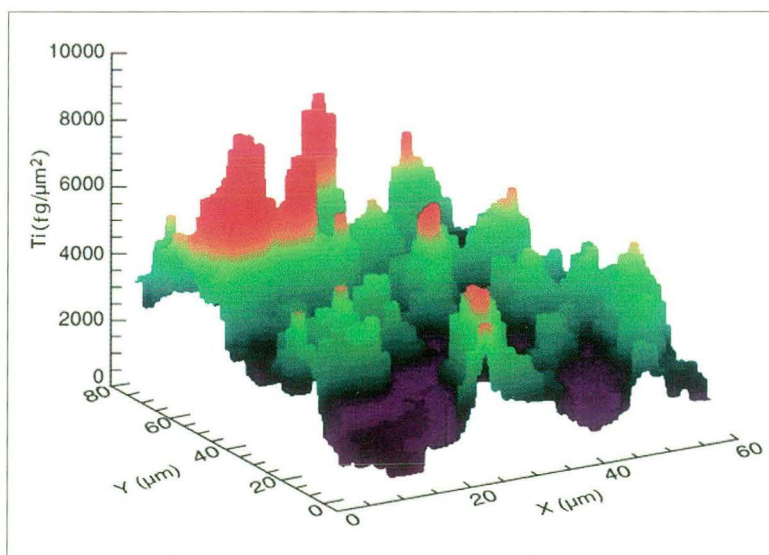

Spatial distribution of titanium in a silicon carbide ceramic from the fluorescence microprobe beamline (Beamline 10.3). Small particles of titanium diboride about 5 μm in diameter can be added to silicon carbide ceramics to improve their mechanical properties, which depend on the uniformity of the distribution of the additive. This scanning x-ray microprobe image indicates that some of the additive has agglomerated into larger particles in this silicon carbide sample.

Defects and cracks are key elements in any mechanism for fracture, and the beamline research group plans to investigate these defects in a variety of ceramic materials of technological interest. Since the elements in the materials have low atomic numbers and K absorption edges below 5 keV, the microprobe is well matched to their study. Additional applications of the microprobe occur in materials science (distribution of doping materials in semiconductors), geology (composition of inclusions in geological materials), and environmental science (profiles of pollutants).

Soft X-Ray Fluorescence

The research teams associated with Beamline 8.0 had much to celebrate on December 10 as the first undulator light reached one of their experimental endstations. Experiments with zero-order light began on the same day and continued through the end of the year, achieving extremely good results during this initial operating period.

The collaborative team of researchers associated with this ALS undulator beamline come from a broad range of scientific backgrounds; including private industry (IBM), government (LBL, Lawrence Livermore National Laboratory, Oak Ridge National Laboratory, National Institute of Standards and Technology), and academia (University of Tennessee and Tulane University). The team's scientific interests lie in the synthesis and characterization of novel surface, interfacial, and material systems. The physics and chemistry of these systems are intrinsically unique due to their two-dimensional and/or multi-elemental character, and as a class represent the next great frontier in the context of microelectronics and high technology.

Initial experiments on Beamline 8.0 emphasized soft x-ray fluorescence (SXF) spectroscopy. In SXF studies, soft x-ray photons are used to excite a selected core level of one element in a complex solid. The radiative emission spectra produced by transitions from filled valence states to the empty core are then measured by a high efficiency soft-x-ray emission spectrometer to obtain information about the density of states of the valence or bonding electrons.

Elemental and angular momentum selectivity coupled with the deep probing character of SXF make fluorescence particularly useful for studies of chemical bonding in complex materials containing several elements, and SXF is a unique tool for the study of the electronic properties of minor constituents and impurities in solids and for buried interfaces and structures. These properties were illustrated by one of the first SXF experiments done on the beamline in which boron K spectra from a single monolayer of boron nitride buried beneath a thick carbon overlayer were obtained by tuning the excitation energy. The intensity of the signal from the monolayer suggests that this technique is sensitive to a number of atoms that would be equivalent to substantially less than a monolayer.

In 1994, the Tennessee/Tulane research team will pursue a variety of studies related to threshold phenomena and to the electronic properties of low concentration elements in complex solids, and the IBM/Livermore contingent will use their photoemission endstation to probe surface systems of relevance to the semiconductor industry.

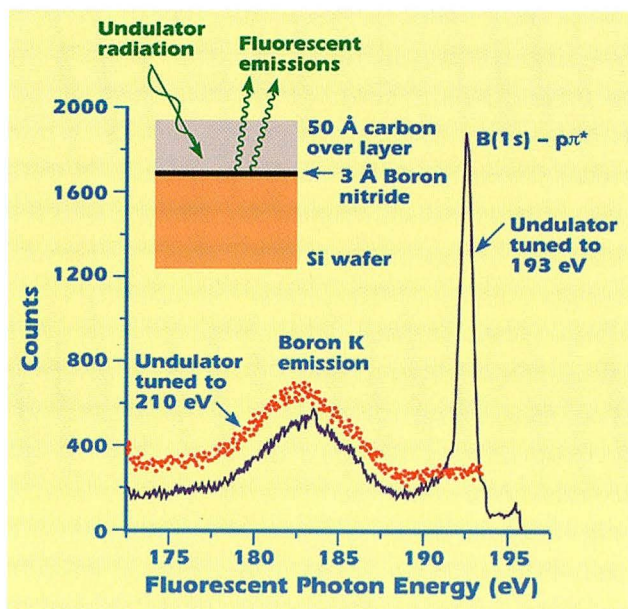

These two spectra, taken in 30 minutes each on Beamline 8.0, represent fluorescence from a single monolayer of boron nitride buried under 50 Å of carbon. The undulator x rays have been tuned to two different energies to differentiate among possible geometries for the boron nitride layer. The sharp peak in the 193 eV spectrum shows the presence of π -bonding in the monolayer.

Beamlines for 1994-1995

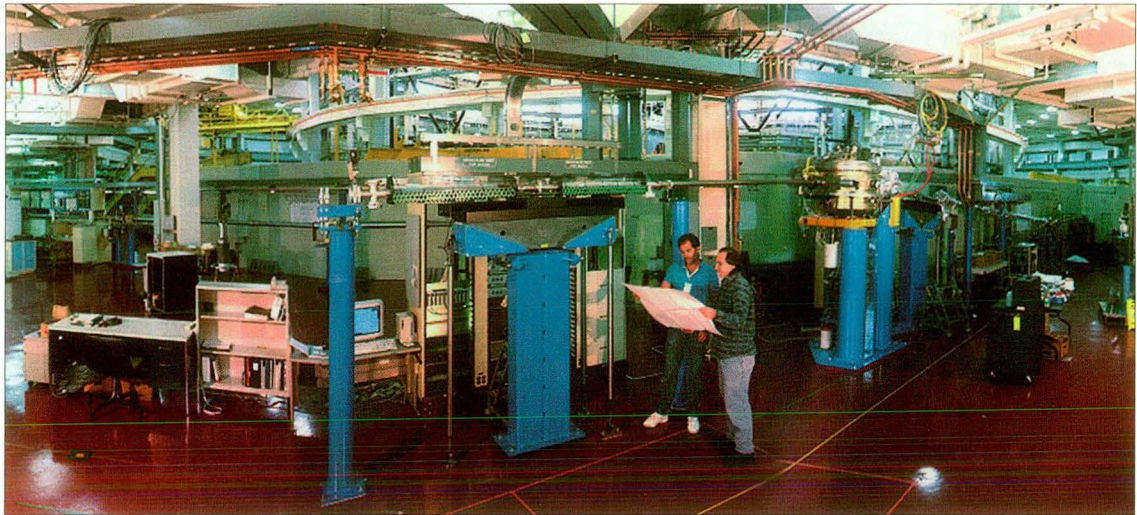

ALS Beamlines for 1994-1995

Beamline	Source	Research	Energy Range	Avail.
3.1	Bend magnet	Diagnostic beamline	200 eV	1994
6.1	Bend magnet	High-resolution zone-plate microscopy	250-600 eV	1994
6.3	Bend magnet	Metrology and standards	50-4000 eV	1994
7.0	U5 undulator	Surfaces and materials, spectromicroscopy	70-1200 eV	Now
8.0	U5 undulator	Surfaces and materials	70-1200 eV	Now
9.0.1	U8 undulator ¹	Atomic physics and chemistry	20-300 eV	1994
9.0.2	U8 undulator ¹	Chemical dynamics	5-30 eV	1994/95
9.3.1	Bend magnet	Atomic and materials science	700 eV-6 keV	1994
9.3.2	Bend magnet	Chemical and materials science	50-1500 eV	1994
10.3	Bend magnet	Materials science and advanced microprobe instrumentation	3-12 keV	Now
11.0	EW20 elliptical wiggler	Materials science and biology, magnetic materials	50 eV-10 keV	1995/96
12.0	U8 undulator	EUV projection lithography, optics development	60-320 eV	1995

¹ Will change to U10 in 1995

Beamline 6.1

Bend magnet beamline 6.1 will be dedicated to high-resolution microscopy. The beamline's x-ray microscope will operate in transmission, providing information about material within a sample, not just on its surface; and will achieve a spatial resolution in the 300-500 Å range when planned improvements are in place. Researchers will be able to analyze samples with thicknesses on the order of 1 to 10 μm, making it an ideal complement to optical and electron microscopes. In addition, state-of-the-art visible light microscopy will be integrated into the beamline, providing experimenters the unique ability to switch back and forth between visible-light and x-ray microscopy.

The scientific program will include studies ranging from materials science to biology. The use of a zone-plate interferometer within the microscope will make it possible to measure certain materials properties such as microscopic optical scattering factors for the first time. The initial biological program will include studies of the higher-order packing of chromatin, and how malaria-causing parasites affect the structure of red blood cells. An important aspect of the biological experiments will be analysis of contrast mechanisms, preparation techniques, and methods of mitigating the effects of radiation.

Beamline 6.3

Beamline 6.3 will provide highly accurate metrology for the development of x-ray optical components, particularly in support of the emerging field of soft x-ray projection lithography. This bend-magnet beamline will have two branchlines, one operating in the 50–700 eV range and the other in the 500–4000 eV range. Within its respective energy range, each branchline will be able to measure the following parameters:

- The reflectance of simple mirrors and multilayer reflectors at all angles of incidence.
- The bidirectional reflectance distribution function.
- The efficiency of diffractive optical elements (e.g., reflection or transmission gratings, zone plates, and crystals).
- The transmission provided by thin-film filters or multilayer beam splitters.
- The polarizing effects of devices designed to modify the polarization properties of a beam.
- The efficiency of electronic detectors, photographic films, and resists.
- Optical constants in the x-ray and extreme ultraviolet (EUV) regions.

In addition, the high throughput, high spectral resolving power, small spot size, and small angular divergence of this beamline will make it possible to perform fundamental experiments in surface and interface physics and chemistry. These areas are of particular importance to our understanding of how x-ray optical devices operate. Additional endstations are planned for photoelectron and x-ray fluorescence spectroscopy involving thin films.

Beamline 7.0

Beamline 7.0 is a 5-cm-period undulator multibranch beamline dedicated principally to spectromicroscopy, which combines the techniques of spectroscopy and microscopy. As a result, experimenters can obtain detailed chemical-state information provided by high-energy-resolution spectroscopy while enjoying the high lateral spatial resolution (from 200 Å to a few microns) made possible by advanced x-ray and electron optics. Researchers will be able to use this beamline to do kinetic studies of surface reactions or to perform photoelectron holography, which provides a 3-D real-space image of the atoms adjacent to an electron emitter.

The endstations for the beamline are currently being developed, but the configuration when complete (early 1995) is slated to include the following:

- Microfocus I (already operational), a small-spot ESCA endstation providing very high spectral resolution.
- Microfocus II, devoted primarily to soft-x-ray fluorescence.
- Nanofocus I, a soft-x-ray microscopy endstation allowing researchers to do scanning photoemission microscopy of samples at UHV pressures and scanning transmission x-ray microscopy of samples at atmospheric pressure.

Beamline 9.0.1

Undulator beamline 9.0.1 will be dedicated to spectroscopic studies of atoms and simple molecules and laser-excited atomic and ionic targets. Major research initiatives will include:

- The study of electron correlation by means of photoelectron coincidence spectroscopy, high-resolution photoelectron spectroscopy, and angle-resolved threshold-time-of-flight photoelectron spectroscopy.
- The core excitation of specific carbon K-edge features in small molecules and the analysis of specific decay products by time-of-flight mass spectrometry.
- The study of highly excited molecules by the use of absorption, photoionization, and photoelectron spectroscopy. Specifically, these techniques will be applied to the core levels of free and adsorbed molecules to determine how the adsorption process changes geometry, bond length, and electronic structure.
- The use of fluorescence detection to increase the spectral resolution of photoionization spectroscopy beyond the level readily obtainable using electron detection.

Beamline 9.0.1 will utilize light from an 8-cm-period undulator when it begins operations in 1994. During 1995, a 10-cm-period undulator will be installed in place of the 8-cm-period device.

Beamline 9.0.2

This undulator beamline will have two endstations. In one of them, a high-intensity (10^{15} photons/sec), low-resolution (2.5%) raw undulator beam will be focused to a spot measuring approximately 100 μm . This enormous flux, 10^3 to 10^4 times higher than most conventional VUV beamlines, will enable a new generation of experiments. The endstation will be used for selective photoionization and product detection in primary photodissociation and chemical reaction dynamics studies. The small spot obtainable from ALS undulator light is expected to improve the mass and energy resolution of ion and electron detection in the proposed experiments.

The other endstation will be equipped with a 6.65-m normal-incidence monochromator with a resolving power of over 100,000, the highest resolution of any scanning monochromator in the world in its spectral region. This endstation will also be equipped with a state-of-the-art photoion photoelectron spectrometer for studies involving the spectroscopy, thermochemistry, and dynamics of radicals and ions. In addition, standard lasers and specially fabricated high-resolution infrared and ultraviolet lasers will be employed in pump-probe and state-to-state dynamics experiments involving both endstations.

Like beamline 9.0.1, this beamline will initially utilize beams from an 8-cm-period undulator, which will be replaced by a 10-cm-period undulator in 1995.

Beamline 9.3.1

This bend-magnet beamline will be equipped with a double-crystal monochromator that will provide a photon-energy range from 700 eV to 6 keV. The scientific program will cover a wide range of areas using high-resolution spectroscopy to study the core-level processes in atoms, molecules, ions, and condensed matter. Specific research topics will include:

- Molecular-orbital symmetry and molecular geometry and orientation. These phenomena will be studied through the examination of polarization and angular distribution in x-ray emission spectroscopy experiments.
- The photoionization of atoms and molecules, which will be studied by means of photoelectron spectroscopy.
- The complex decay patterns associated with core-hole production by x-ray absorption, which will be analyzed through the use of ion-yield spectroscopy.

- Enzymes that contain metals in very low concentrations (i.e., 100 ppm or less). The extended x-ray absorption fine structure (EXAFS) approach will be applied to the investigation of such metalloproteins. In addition, time-resolved “flow-pump-probe” x-ray absorption spectroscopy will be used to monitor photochemical reactions initiated by a laser.

Beamline 9.3.1 will also be used to develop advanced diffraction elements with multilayer coatings for use in x-ray optics.

Beamline 9.3.2

Bend magnet beamline 9.3.2 is equipped with a state-of-the-art endstation employing advanced multichannel electron detection and the normal tools of UHV based surface science. It is equipped with a monochromator that supplies photons over an energy range of 50 to 1500 eV, with a resolving power of up to 10,000 for a variety of experiments that use photon and electron spectroscopy.

The research program focuses on a wide range of problems in chemistry and materials science, including:

- High-energy chemical physics. Areas of particular interest include the threshold photoionization of free molecules, with special attention to electron correlation and vibrational fine structure; surface structure, especially surface-atom relaxation on clean surfaces and the identification of structures containing identical atoms in varying chemical environments; and photoionization shape resonances in condensed matter.
- Interfaces and nanostructures in the surfaces of technologically critical metals and semiconductors. This research focuses on electronic, atomic, and magnetic structures in such surfaces and the growth of nanostructures and microclusters on them.
- Interactions between solvated ions and metal surfaces. The focus in this area is on studying the water solvation shell around adsorbed atoms and changes in the positions of metal atoms around ion sites.
- The adsorption of molecules onto surfaces. Phenomena to be investigated include interatomic distances, molecular orientations, and the electronic structure of reaction intermediates on transition-metal surfaces.

Beamline 11.0

This beamline will be equipped with a 20 cm-period elliptical wiggler, which will produce beams of circularly polarized x rays in the energy range between 50 eV and 10,000 eV. The beamline will also have both grating and crystal monochromators to provide high spectral resolution over this wide energy range.

Applications utilizing circular polarization range from fundamental measurements of circular dichroism in atomic and molecular physics to applied studies in materials and biological science. In particular, the use of circularly polarized radiation will make it possible to apply new techniques designed to probe the spin state of matter. These new techniques include:

- X-ray magnetic circular dichroism in absorption, using both the near-edge region for electronic information (the NEXAFS approach) and the higher-energy region for structural information (the EXAFS approach).
- Polarization-dependent x-ray scattering.
- Circular dichroism in soft x-ray photoemission.
- Spin dependent imaging.

One focus of study will be the spin states of metal centers in metallo-proteins and metalloenzymes. In addition, the spin information obtained from circular dichroism techniques will be used in experiments designed to determine magnetic order. The yield of photoelectrons can be imaged using a simple electrostatic electron microscope, and the difference in yield using right- and left-circularly polarized radiation can be used to form a map of a surface, revealing magnetic order.

Beamline 12.0

The primary branchline on undulator beamline 12.0 will be dedicated to developing the metrological capabilities required to support the evolution of extreme-ultraviolet (EUV) projection lithography as the technology of choice for semiconductor manufacturing. Ultimately, the hope is to provide the technology for measuring the surface figures of individual reflective optical elements and the wavefronts of assembled systems accurately enough to make EUV projection lithography commercially viable.

Because such optical elements will have multilayered reflection coatings that are angle- and wavelength-sensitive, their surfaces must be tested at the wavelength of operation. Partially coherent undulator radiation with wavelengths between 40 Å and 200 Å will make such characterization possible. A critical facet of this program will be the development of EUV interferometry, which requires spatially coherent radiation at the coating wavelength.

Two additional branchlines for ancillary research are planned. One of these will be dedicated to the development of new applications of interferometry to x-ray optics. The other will allow the rapid assembly and evaluation of coherent-optics experiments, such as the study of the effects of long-term soft x-ray exposure on multilayer mirrors.

Special Events



ADVANCED LIGHT SOURCE DEDICATION CEREMONY

Friday, October 22, 1993, at 11 a.m.

Lawrence Berkeley Laboratory
Berkeley, California

The Advanced Light Source produces bright beams of x-ray and ultraviolet light that outshine any in the world. Designated by the U.S. Department of Energy as a national user facility, the ALS will serve researchers in a broad range of scientific fields.

Watching former LBL Director Dave Shirley cut the ribbon at the ALS dedication ceremony were (from left) Jay Marx, Don Pearman, Martha Krebs, Gayle Wilson, Brian Kincaid, Charles Shank, and Hermann Grunder.

ALS Celebrates Grand Opening

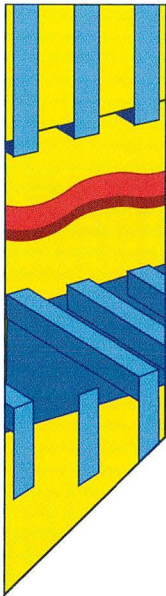

Brilliance was in abundance as supporters of the Advanced Light Source from around the world gathered at the official dedication ceremony on October 22. Bright sunlight and the crowd's beaming faces added plenty of sparkle to the grand opening celebration.

Government officials, scientific leaders, and newspaper and television reporters joined hundreds of LBL staff members to attend the ribbon-cutting ceremony marking the official opening of the \$150 million state-of-the-art facility. The event was honored by the attendance of Gayle Wilson, wife of California Governor Pete Wilson, who, as former U.S. Senator, helped procure funding for ALS construction.

LBL Director Charles Shank opened the festivities by describing the dedication ceremony as both an end and a beginning: "We have finished the construction project on time and on budget and we are now beginning the scientific program which will be the ultimate measure of our success. Today we celebrate the truly extraordinary accomplishments of everyone who made this project succeed."

Shank called special attention to six individuals who were critically important to the project's success: Jay Marx, Dave Attwood, Ron Yourd, Alan Jackson, Klaus Halbach, and Klaus Berkner. "Without Jay Marx's initial leadership, this project would not be the success it is today. Our laboratory takes special pleasure and pride in his unique

talents. Dave Attwood kept the ALS flame burning in the scientific community. Ron Yourd displayed remarkable project management skills. Alan Jackson led an international accelerator team that designed an ALS that worked the first time. Klaus Halbach gave enormous creativity and spiritual leadership. And finally, Klaus Berkner drove the technical design and formed the organization that brought the Light Source to fruition."



Don Pearman, manager of DOE's San Francisco Operations Office, reads a message from Energy Secretary Hazel O'Leary expressing her appreciation to the ALS staff for a job well done.

Second to speak was Dave Shirley, former director of LBL and now senior vice president for research and dean of the graduate school at Penn State. Often referred to as the “father of the ALS,” Shirley explained how the concept for the ALS developed in early 1982. “The scientific case for a third generation light source seemed so compelling that we couldn’t resist going ahead. We were, as the phrase goes, running a little out in front of our headlights. But, before long, the idea pulled together and has been rapidly moving forward ever since.”

Shirley concluded by speculating on what the future has in store for the ALS. “I think that when people look back from the perspective of the 25th anniversary of this dedication, they will see experiments done that we couldn’t imagine today in a variety of fields. I think we will see nanostructures, micromachining, and many other new fields opening up that we can only dream of. So for me, this is the culmination and the realization of what was once referred to by Dave Attwood as *the impossible dream*.”

ALS Team Shares Credit

LBL Associate Director Martha Krebs took the podium as it was officially announced that she was President Clinton’s nominee for the director of DOE’s Office of Energy Research. She pointed out that one of the greatest challenges she will face in going to Washington is “to try to convey what institutions like LBL, and the other national laboratories, can bring to the performance of science—that we have something very special.”

A very entertaining talk was given by Hermann Grunder, who now directs the Continuous Electron Beam Accelerator Facility in Newport News, Virginia. Grunder was the head of LBL’s Accelerator and Fusion Research Division when the ALS was first proposed and played a major role in bringing the ALS to LBL. He described Berkeley as the place where big science was invented (a reference to E. O. Lawrence’s 184-inch Cyclotron on the present site of the ALS) and a place where it still happens.

Brian Kincaid, director of the ALS, thanked members of LBL, the DOE, and the scientific community for their extraordinary work to make the project a success. “We have a very special team at the ALS and the work that has been done here is absolutely amazing to me. You can’t go out and buy one of these things—you have to have a group of people who are willing to take responsibility to do it.” He concluded by thanking Jay Marx for his exceptional leadership as ALS Director from 1987 until 1992.

DOE Offers Congratulations

Shank introduced the next speaker, Don Pearman, as one of the best friends that LBL has. Pearman is manager of DOE's San Francisco Operations Office and acting associate deputy secretary for Field Management. He described the ALS as "a shining example of Energy Secretary O'Leary's vision for accelerating the technology of partnerships into every one of the missions of the department. The fact that the ALS works, and was completed on time and within budget is a magnificent testament to the fact that total quality management really is alive and well at LBL and in DOE." Pearman read a personal note from Secretary O'Leary who was unable to attend the Dedication: "I want to express my appreciation to the ALS team for a job well done. This facility will make an important contribution to providing the scientific and technical foundation for a more productive and competitive economy and more efficient use of energy. We can all be proud to declare the ALS open for business."

The ceremony ended on a high note with the presentation of DOE Distinguished Associate Awards to Jay Marx and Brian Kincaid for their outstanding contributions to the ALS project. Iran Thomas, director of the DOE Materials Science Division, thanked Marx for his exceptional leadership of the ALS team during project design and construction, and complemented Kincaid for his outstanding contribution as project director during commissioning and initial operation.

tribution as project director during commissioning and initial operation.



Hundreds of people gathered to celebrate the grand opening of the ALS at the official dedication ceremony.

ALS Users' Association Meeting

The opportunity to see the first experimental results from ALS beamlines attracted a record number of persons to the Advanced Light Source Users' Association Annual Meeting held on October 21 and 22, 1993. For most of the 220 attendees, this was the first chance to see the ALS in operation and view the initial set of beamlines on the experimental floor. The meeting program focused on the scientific opportunities offered by the ALS' ability to produce the world's brightest beams of ultraviolet and soft x-ray synchrotron radiation. A special highlight was the chance to participate in the ALS dedication ceremony.

Organized by Users' Executive Committee Chair Dave Ederer (Tulane University), the program began with a welcome by LBL Director Charles Shank. Shank encouraged everyone to join LBL in the challenge of creating a world-class scientific program at the ALS that would fully exploit its capabilities.

Following Shank's remarks, ALS Director Brian Kincaid gave an account of the facility's progress during the past year and outlined plans for the first year of operations. After a highly successful accelerator commissioning run in the spring, the ALS focused its efforts on installing the beamlines and instrumentation for the first phase of operations. Kincaid reported that three of the initial set of five beamlines were already operational: the x-ray microprobe bending-magnet beamline, an undulator beamline, and the diagnostic beamline. He concluded by thanking everyone involved for their contributions to the remarkable success of the ALS.

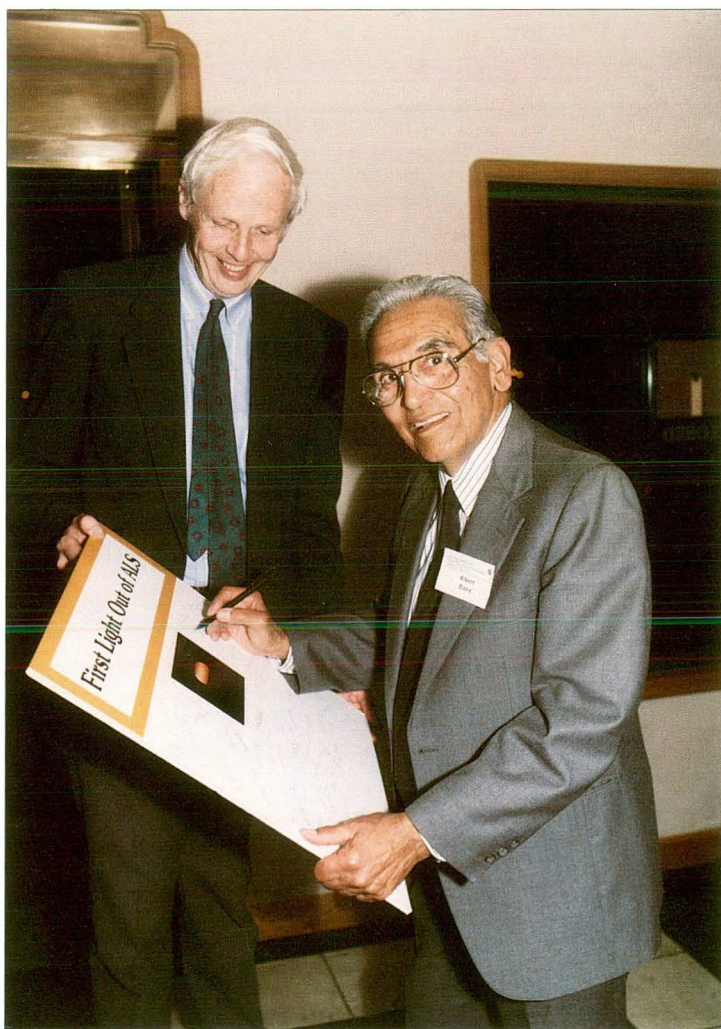

Banquet speaker Albert Baez signs a poster held by Al Thompson commemorating the first light delivered to the Center for X-Ray Optics microprobe beamline.

Dave Shirley (Pennsylvania State University), who was LBL's director when the ALS was conceived, noted with satisfaction that the completion of the facility brought the scientific community to the threshold of a dramatic new opportunity. He emphasized the importance of developing experimental apparatus, particularly high-performance detectors, that can take full advantage of the qualities of the ALS light. Next Neville Smith (AT&T Bell Laboratories) discussed his role as head of the ALS Program Review Panel. The Panel, whose membership provides a balanced representation of the major scientific and engineering disciplines covered by the ALS, gives advice on the disposition of proposals for the development and use of ALS experimental facilities.

The last speaker of the morning was Glen Dahlbacka from LBL's Technology Transfer Department who spoke about industrial opportunities at the ALS. He discussed two proposals currently under consideration of interest to industry: an x-ray crystallography beamline and a micro-fabrication facility. The crystallography beamline would form the heart of a user facility for protein study to assist industry in the areas of rational pharmaceutical design and development of new commercial catalysts. The proposed microfabrication facility would use deep x-ray lithography for the production of micromachines such as precision gears for watches, accelerometers for use in automobile airbags, and miniature instruments for microsurgery.

Results from First Beamlines

Howard Padmore, ALS Experimental Systems Group Leader, talked about the first experimental results from the operational beamlines along with plans for future beamlines. He showed an image of the beam taken from the CCD detector at the end of the diagnostic beamline and a spectrum obtained with the transmission grating spectrometer being used to measure the light from the recently operational 5-cm-period undulator.

Fred Schlachter, ALS User Liaison Group Leader, described the efforts of the ALS to develop new research opportunities and to provide an efficient working environment for users. To complete the overview of user issues, acting ALS EH&S Program Manager Georgeanna Perdue gave a short talk describing her role in making the ALS a safety-conscious facility and outlining the training requirements for ALS users.

Richard White (University of California at Berkeley) spoke on the research being done by the Berkeley Sensor and Actuator Center (BSAC) to develop a science and engineering base for microsensors, microactuators, mechanical microstructures, and microdynamic systems. White pointed out that the ability to make much thicker micromachines

by using the light of the ALS offers many advantages, such as an increase in volume which provides more mass and strength, and the possibility of using alternative materials and fabrication methods.



Part of the research team for Beamline 7.0 gather at the popular Chinese banquet on Thursday evening. Pictured are (left to right): Tony Warwick, Piero Pianetta, Marjorie Olmstead, Jeffrey Bokor, Jim Tobin, Brian Tonner, and Harald Ade.

Albert Thompson (LBL Center for X-Ray Optics) finished the day's program with an exciting report about the results from the x-ray fluorescence microprobe, the first beamline at the ALS. Thompson pointed out a few of the many advantages of the microprobe, such as small spot size ($1\ \mu\text{m}$ by $1\ \mu\text{m}$) and femtogram elemental sensitivity. The talk included several examples of how the microprobe will be used for research in materials sciences.

Among these were investigating how trace elements are distrib-

uted in ceramics, mapping the composition of fluid inclusions in quartz samples for geological studies, and elemental analysis of ancient documents.

That evening, the conference banquet featured a special talk by Albert Baez on the early days of x-ray optics. In 1948, Kirkpatrick and Baez devised an imaging system to eliminate the astigmatism of a single mirror used at glancing incidence. The mirror scheme turned out to be very useful in many x-ray optics applications. In fact, many modern beamlines including the microprobe and diagnostic ALS beamlines employ configurations that are similar to the Kirkpatrick-Baez scheme.

Spotlight on Spectroscopy

The second day began with a session devoted to spectroscopy in the soft x-ray spectral region served by the ALS. Gerhard Materlik (Hamburger Synchrotronstrahlungslabor) described experiments using x-ray standing waves in the soft x-ray region. He noted several advantages of using soft x rays, including accessibility of atoms with low atomic numbers and the possibility of using several probes in addition to the conventional fluorescence.

Günter Kaindl (Freie Universität Berlin) presented an overview of high-resolution spectroscopy experiments using the SX-700 II plane-grating monochromator, which has demonstrated a resolving power of up to 16,000 at a photon energy of 65 eV. Joseph Nordgren (Uppsala University) ended the morning session with a discussion of soft x-ray emission spectroscopy. In providing information about unfilled states, soft x-ray emission provides information complementary to that from photoabsorption and photoemission.

Paolo Carra (European Synchrotron Radiation Facility) began the afternoon talks with a discussion of the theoretical aspects of magnetic circular dichroism (MCD) and linear dichroism. Steven Cramer (University of California at Davis) described biological applications of soft x-ray and MCD spectroscopy. He noted the elliptical wiggler being designed and constructed by the ALS could increase by a few orders of magnitude the flux of polarized light relative to that from bend magnet beamlines.

The final speaker, Yuan Lee (University of California at Berkeley), discussed plans for a chemical dynamics 8-cm-period undulator branchline for research on primary photodissociation and photoionization processes. The branchline has two primary end stations, one using white undulator light and the other using monochromatized radiation. The experimental end stations will be a complex system using pump-and-probe techniques with high power lasers and crossed molecular beams.

Elliptical Wiggler Workshop

Approximately 40 scientists and engineers gathered at the ALS on April 19 to discuss the production and use of elliptically polarized radiation. The objective was to exchange views on the scientific and technical cases for the 20-cm-period elliptical wiggler that is presently being designed at the ALS (see Insertion Devices on page 32). An additional purpose of the meeting, chaired by Phil Heimann and Fred Schlachter of the ALS, was to discuss an eventual second insertion device to produce elliptically polarized radiation at the ALS, such as a crossed undulator.

Elliptically polarized vacuum-ultraviolet (VUV) and x-ray radiation is of considerable interest as a tool for probing matter. There are many areas of application such as materials and surface sciences, atomic and molecular physics, chemistry, and biological science. Possible benefits to industry include a better understanding of the characteristics of magnetic materials, and the development of new materials with greatly increased magnetic storage capacities.

Several workshop participants gave brief scientific presentations describing experiments that would take advantage of elliptically polarized light produced by an elliptical wiggler. The proposals covered a variety of scientific disciplines and demonstrated a high level of interest in elliptically polarized photons over a broad energy range. Some of the applications discussed were circular dichroism and magnetic circular dichroism effects as manifested in x-ray absorption; photoelectron emission and diffraction; and x-ray fluorescence from a wide range of systems including gas-phase specimens, biological molecules, adsorbates, and magnetic materials. For magnetic materials, these measurements include the element-specific imaging of individual structures in magnetic storage devices, as well as studies of dilute or weak magnetic systems, multilayer and low-dimensional magnetic structures, high-temperature superconductors, element-specific magnetic phase transitions, and so-called "complete" experiments in which all physical variables, including the direction and spin of the outgoing photoelectrons, are measured.

Talks by ALS scientists included an overview of insertion devices for elliptical polarization, the performance of an elliptical wiggler and crossed undulator, the hybrid-electromagnet elliptical wiggler design at the ALS, and possible designs for associated beamlines. A report of the workshop is available from the ALS upon request.

Soft X-Ray Interferometry Workshop

The ALS hosted an informal workshop on soft x-ray interferometry on June 25 to discuss its proposed technical design for a Fourier-transform spectrometer (FTS). Chaired by ALS scientists Malcolm Howells and Zahid Hussain, the meeting invited discussion of different design strategies for the instrument's components, detection methods, signal processing issues, and ways of meeting the manufacturing tolerances that are necessary for the instrument to achieve the desired levels of performance.

There are a number of problems in the physics of atoms and small molecules that challenge the resolution of the diffraction grating spectrometers that are traditionally used for VUV and soft x-ray experiments at synchrotron radiation facilities. The limit of current technology is a resolution of about 0.003–0.01 Å, which is easier to get with a spectrograph than with a scanning monochromator. This translates into a resolving power of 20,000–60,000 at 60 eV for example.

The ALS is designing a soft x-ray FTS with a resolving power target of 500,000 at 60 eV. Fourier-transform spectrometers, successfully used in the infrared and the ultraviolet regions, utilize a two-beam interferometer to measure the Fourier transform of the desired spectrum. The ALS is attempting to extend the FTS technology into the soft x-ray region up to 100 eV. This will allow the principle of FTS to be applied to soft x-ray photoabsorption experiments with the goal of obtaining much higher resolution than is possible with a grating. For example, the ALS soft x-ray FTS system should allow the discovery of many new and extremely narrow resonances, now accessible only by theory, and to measure true line-shape parameters. This is directed principally toward studies of helium atoms in the region of their double ionization threshold (60–80 eV), but applications also include other atomic and small molecular systems.

Among the workshop presentations were "The Scientific Origins of the LBL Soft X-Ray Interferometer Project" by Dave Shirley of Penn State, and "Fourier Transform Spectroscopy: A Sketch Map to Lyman Alpha and Beyond" by Anne Thorne of Imperial College, London. Presentations by ALS staff members concentrated on the technical issues involved in implementing the spectrometer. A report of the workshop is available from the ALS upon request.

- F. Cerrina, A.K. Ray-Chaudhuri, W. Ng, S. Liang, S. Singh, J.T. Welnak, J.P. Wallace, C. Capasso, J.H. Underwood, J.B. Kortright, and R.C.C. Perera, "Microscopic-scale lateral inhomogeneities of photoemission response of cleaved GaAs," *Appl. Phys. Lett.* **63**, 63 (1993).
- R. DiGennaro and T. Swain, "Engineering for high heat loads on ALS beamlines, II," in *Proceedings of the International Symposium on Optical Applied Science and Engineering* (San Diego, CA, 1993); LBL-33215a (1993).
- R. DiGennaro, T. Swain, N. Andersen, and T. Warwick, "Water-cooled entrance slit for high power x-ray beamlines," in *Proceedings of the International Symposium on Optical Applied Science and Engineering* (San Diego, CA, 1993); LBL-33213a (1993).
- M. Fahmie, "Design of the ALS timing system," in *Proceedings of the IEEE Particle Accelerator Conference* (Washington, D.C., 1993); LBL-33307a (1993).
- W.G. Graham, K. H. Berkner, E.M. Bernstein, M.W. Clark, H. Crawford, B. Feinberg, I. Flores, I. Greiner, M.A. McMahan, R.J. McDonald, P.M. Mokler, T.J. Morgan, W. Rathbun, A.S. Schlachter, and J.A. Tanis, "Electron capture and loss cross sections for collisions of GeV U^{89+} and U^{90+} projectiles with light targets," 18th International Conference on the Physics of Electronic and Atomic Collisions (Aarhus, Denmark, 1993).
- K. Halbach and R. Schlueter, "Simulating a singularity-free universe outside the problem boundary in Poisson," *Computational Accelerator Physics Conference* (Pleasanton, CA, 1992); LBL-33868 (1992).
- P. Heimann, T. Warwick, M. Howells, W. McKinney, D. Digennaro, B. Gee, D. Yee, and B. Kincaid, "The Advanced Light Source U8 beamline, 20–300eV," *Nucl. Instrum. Meth. A* **319**, 106 (1992); LBL-32155 (1991).
- J. Hinkson, "Performance of Advanced Light Source particle beam diagnostics," in *Proceedings of the IEEE Particle Accelerator Conference* (Washington, D.C., 1993); LBL-33292 (1993).
- J. Hinkson, "The Advanced Light Source beam diagnostics systems," *Beam Instrumentation Workshop* (Sante Fe, NM, 1993); LBL-34747 (1993).
- M. Howells, "X-ray lithography by holographic projection: a new twist to proximity printing," abstract for the *Soft X-Rays in the 21st Century Conference* (Provo, UT, 1993); LBL-33366a (1993).
- M.R. Howells, K. Frank, Z. Hussain, E. J. Moler, T. Reich, D. Möller, and D. A. Shirley, "Toward a soft x-ray Fourier-transform spectrometer," *Nucl. Instrum. Meth.* (in press); 8th National Conference on Synchrotron Radiation (Gaithersburg, MD, 1993); LBL-34798 (1993).
- M.R. Howells, C. J. Jacobsen, and S. Lindaas, "X-ray holographic microscopy using the atomic force microscope," in *Proceedings of the 4th International Conference on X-ray Microscopy* (Chenogolovka, Russia, 1993); LBL-34663 (1993).
- M. Howells and D. Lunt, "Design considerations for adjustable-curvature, high-power, x-ray mirrors based on elastic bending," *Optical Engineering* **32**, 8 (1993); LBL-34320 (1993).
- E. Hoyer, "High power photon beamline elements in the LBL/SSRL/Exxon Beamline VI," in *B Factories: The State of the Art in Accelerators, Detectors, and Physics* (Stanford, CA, 1992); LBL-32981 (1992).
- E. Hoyer, J. Chin, B. Gath, D. Humphries, B. Kincaid, S. Marks, D. Plate, and G. Portman, "First undulators for the Advanced Light Source," in *Proceedings of the IEEE Particle Accelerator Conference* (Washington, D.C., 1993); LBL-33197 (1993).
- E. Hoyer, J. Chin, and W. Hassenzahl, "Flux shunts for undulators," in *Proceedings of the IEEE Particle Accelerator Conference* (Washington, D.C., 1993); LBL-33224 (1993).
- Z.Q. Huang, Z. Hussain, W.T. Huff, E. Moler, and D.A. Shirley, "Structural determination of $p2mg(2 \times 1)CO/Ni(110)$ using angle-resolved photoemission extended fine structure," *Phys. Rev. B* **48**, 1696 (1993); LBL-32713 (1993).

- Z.Q. Huang, L.-Q. Wang, A.E.S. von Wittenau, Z. Hussain, and D.A. Shirley, "ARPEFS study of the structure of p(2x2)K/Ni(111)," *Phys. Rev. B* **47**, 13626 (1993); LBL-33041 (1992).
- E. Hudson, E. Moler, Y. Zheng, S. Kellar, P.A. Heimann, Z. Hussain, and D.A. Shirley, "High resolution core-level photoabsorption of alkali halides," in *Proceedings of the Materials Research Society* **307**, 83 (1993); LBL-34357 (1993).
- D. Humphries, J. Chin, R. Connors, J. Cummings, T. Keffler, E. Gath, E. Hoyer, B. Kincaid, and P. Pipersky, "Precision alignment of the ALS U5 and U8 undulators," in *Proceedings of the International Symposium on Optical Applied Science and Engineering* (San Diego, CA, 1993); LBL-33237a.
- D. Humphries, K. Halbach, E. Hoyer, B. Kincaid, S. Marks, and R. Schlueter, "Modeling and measurements of the ALS U5 undulator end magnetic structures," in *Proceedings of the IEEE Particle Accelerator Conference* (Washington, D.C., 1993); LBL-33236a (1993).
- D. Humphries, E. Hoyer, B. Kincaid, S. Marks, and R. Schlueter, "Magnet sorting algorithms for insertion devices for the Advanced Light Source," 13th International Conference on Magnet Technology (Victoria, B.C., Canada, 1993); LBL-34644 (1993).
- S. Irick, "Improved measurement accuracy in a long trace profiler: compensation for laser pointing instability," *Nucl. Instrum. Meth.* (in press); 8th National Conference on Synchrotron Radiation Instrumentation (Gaithersburg, MD, 1993); LBL-34603 (1993).
- A. Jackson, "Commissioning and performance of the Advanced Light Source," in *Proceedings of the Particle Accelerator Conference* (Washington, D.C., 1993); LBL-33240 (1993).
- L.T. Jackson, K. Luchini, and I. Lutz, "Magnet power supply system for the ALS storage ring and booster," in *Proceedings of the IEEE Particle Accelerator Conference* (Washington, D.C., 1993); LBL-33294a (1993).
- R. Keller, "Final analysis of the ALS lattice magnet data," in *Proceedings of the IEEE Particle Accelerator Conference* (Washington, D.C., 1993); LBL-33221 (1993).
- R. Keller, "Survey and alignment data analysis for the ALS storage ring," in *Proceedings of the IEEE Particle Accelerator Conference* (Washington, D.C., 1993); LBL-33220 (1993).
- R. Keller, "Survey and alignment data analysis for the ALS storage ring using computer spreadsheets," 13th International Workshop on Accelerator Alignment (Annecy, France, 1993); LBL-34335 (1993).
- C. Kim, "Performance of the ALS injection system," in *Proceedings of the IEEE Particle Accelerator Conference* (Washington, D.C., 1993); LBL-33239a (1993).
- Kim, K.-J., C. Pellegrini, and H. Winick, "A high power short wavelength FEL using the SLAC linac," 8th National Conference on Synchrotron Radiation (Gaithersburg, MD, 1993); LBL 34049 (1993)."
- J. Kirz, H. Ade, E. Anderson, C. Buckley, H. Chapman, M. Howells, C. Jacobsen, C.-H. Ko, S. Lindaas, D. Sayre, S. Williams, S. Wirick, and X. Zhang, "New results in soft x-ray microscopy," *Nucl. Instrum. Meth.* (in press); Conference on X-ray and Inner Shell Processes (Debrecen, Hungary, 1993).
- M. Koike, P.A. Heimann, A.H. Kung, T. Namioka, R. DiGennaro, B. Gee, and N. Yu, "VUV high resolution and high flux beamline for chemical dynamics studies at the Advanced Light Source," *Nucl. Instrum. Meth.* (in press).
- S. Lindaas, C. Jacobsen, and M.R. Howells, "A linear field scanning force microscope: application to x-ray Gabor holography," abstract submitted to the Microscopy Society of America annual meeting (New Orleans, LA, 1994).
- S. Lindaas, C. Jacobsen, and M.R. Howells, "X-ray Gabor holography: improvements utilizing a linear field scanning force microscope to read out the resists," abstract for the Optical Society of America conference (Toronto, Canada, 1993).

- J. Llacer and M.R. Howells, "Maximum likelihood estimator image reconstruction algorithm for x-ray holography," LBL-33768 (1993).
- H. Lancaster, J. Hinkson, S. Magyary, G. Portmann, and T. Warwick, "The photon feedback system for the ALS," in *Proceedings of the IEEE Particle Accelerator Conference* (Washington, D.C., 1993); LBL-33293a (1993).
- J. Llacer and M.R. Howells, "The relationship between image quality and radiation dose in low energy x-ray absorption tomography," LBL-34000 (1993); preprint submitted to *Applied Optics*.
- E. Louis, H.J. Voorma, N.B. Koster, L. Shmaenok, F. Bijerk, R. Schlatmann, J. Verhoeven, Yu. Ya. Platonov, G.E. van Dorssen, and H.A. Padmore, "Enhancement of reflectivity of multilayer mirrors for soft x-ray projection lithography by temperature optimization and ion bombardment," in *Proceedings of Microcircuit Engineering* (Maastricht, Netherlands, 1993) (in press).
- C.C. Lo, "The ALS gun electronics system," in *Proceedings of the IEEE Particle Accelerator Conference* (Washington, D.C., 1993); LBL-33189a (1993).
- C.C. Lo and B. Taylor, "The phase-servo tuner control system of the ALS 500 MHz cavity," in *Proceedings of the IEEE Particle Accelerator Conference* (Washington, D.C., 1993); LBL-33190a (1993).
- S. Magyary, "Anatomy of a control system: a system designer's view," in *Proceedings of the IEEE Particle Accelerator Conference* (Washington, D.C., 1993); LBL-33196a (1993).
- S. Marks, "Precise integration of undulator hall probe scans," 13th International Conference on Magnet Technology (Victoria, B.C., Canada, 1993); LBL-34643 (1993).
- S. Marks, C. Cork, E. Hoyer, D. Humphries, B. Kincaid, D. Plate, A. Robb, R. Schlueter, C. Wang, J. Bahrtdt, and W. Hassenzahl, "Insertion device magnet measurements for the Advanced Light Source," in *Proceedings of the IEEE Particle Accelerator Conference* (Washington, D.C., 1993); LBL-33229 (1993).
- S. Marks, C. Cork, D. Humphries, D. Plate, A. Robb, R. Schlueter, and W. Hassenzahl, "The magnet measurement facility for characterization of ALS insertion devices," abstract for the 13th Conference on Magnet Technology (Victoria, B.C., Canada, 1993); LBL-33459a (1993).
- S. Marks, D. Humphries, B. Kincaid, R. Schlueter, and C. Wang, "Analysis of insertion device magnet measurements for the Advanced Light Source," in *Proceedings of the International Symposium on Optical Applied Science and Engineering* (San Diego, CA, 1993); LBL-33341 (1993).
- W. McKinney and S. Irick, "XUV synchrotron optical components for the Advanced Light Source: summary of the requirements and the developmental program," International Symposium on Optical Applied Science and Engineering (San Diego, CA, 1992); LBL-33068 (1992).
- W. R. McKinney and C. Palmer, "Imaging theory of plane-symmetric varied line-space grating systems," *Optical Engineering* (in press).
- W. McKinney, C.L. Shannon, and E.N. Shults, "Water-cooled ion-milled diffraction gratings for the synchrotron radiation community," 8th National Conference on Synchrotron Radiation Instrumentation (Gaithersburg, MD, 1993); LBL-34670 (1993).
- D.A. Mossessian, P.A. Heimann, E. Gullikson, R.K. Kaza, J. Chin, and J. Akre, "Transmission grating spectrometer for characterization of undulator radiation," *Nucl. Instrum. Meth.* (in press).
- W. Ng, A.K. Ray-Chaudhuri, S. Liang, S. Singh, H. Solak, J. Welnak, F. Cerrina, G. Margaritondo, J. H. Underwood, J.B. Kortright, and R.C.C. Perera, "High resolution nanospectroscopy with MAXIMUM: photoemission spectroscopy reaches the 1000Å scale," *Nucl. Instrum. and Meth.* (in press).
- H. Nishimura, "Dynamic accelerator modeling," in *Proceedings of the IEEE Particle Accelerator Conference* (Washington, D.C., 1993); LBL-33223 (1993).

- H. Nishimura, "Object-oriented software construction at ALS," International Conference on Accelerator and Large Experimental Physics Control (Berlin, Germany, 1993); LBL-34720 (1993).
- H.A. Padmore, V. Martynov, and K. Hollis, "The use of diffraction efficiency theory in the design of soft x-ray monochromators," Nucl. Instrum. Meth. (in press); 8th National Conference on Synchrotron Radiation Instrumentation (Gaithersburg, MD, 1993); LBL-34730 (1993).
- T. Reich, Z. Hussein, E. Moler, M. Blackwell, G. Kaindl, D. A. Shirley, and M. R. Howells, "High-resolution in the soft x-ray range from a toroidal grating monochromator," Rev. Sci. Instrum. **64**, 2552-7 (1993); LBL-33629 (1993).
- A. Ritchie and D. Oldfather, "The ALS radiation safety system," in *Proceedings of the IEEE Particle Accelerator Conference* (Washington, D.C., 1993); LBL-33290a (1993).
- A.L. Robinson and A.S. Schlachter, "Initial experimental program at the Advanced Light Source," 8th National Conference on Synchrotron Radiation Instrumentation (Gaithersburg, MD, 1993).
- R.D. Schlueter and G.A. Deis, "A tunability enhanced electromagnetic wiggler," Nucl. Instrum. Meth. A **319**, 711-714 (1993); LBL-33916 (1992).
- R.D. Schlueter and K. Halbach, "Harmonics suppression in electromagnets with application to the ALS storage ring corrector magnet design," 13th International Conference on Magnet Technology (Victoria, B.C., Canada); LBL-32028 (1991).
- R. Schlueter and K. Halbach, "Harmonics suppression of vacuum chamber eddy currents induced fields with application to SSC low energy booster magnets," 13th International Conference on Magnet Technology (Victoria, B.C., Canada, 1993); LBL-34659 (1993).
- R. Schlueter and K. Halbach, "Skew harmonics suppression in electromagnets with application to the Advanced Light Source (ALS) storage ring corrector magnet design," 13th International Conference on Magnet Technology (Victoria, B.C., Canada, 1993); LBL-34660 (1993).
- R. Schlueter, K. Halbach, E. Hoyer, D. Humphries, and S. Marks, "Multipole suppression in the Advanced Light Source (ALS) U5.0 undulator," in *Proceedings of the 13th International Conference on Magnet Technology* (Victoria, B.C., Canada, 1993); LBL 33480 (1993).
- N.V. Smith and M.R. Howells, "Whispering galleries for the production of circularly polarized synchrotron radiation in the XUV region," Nucl. Instrum. Meth. (in press); 8th National Conference on Synchrotron Radiation (Gaithersburg, MD, 1993).
- G. Stover and L. Reginato, "Design and preliminary results for a fast bipolar resonant discharge pulser using SCR switches or driving the injection bump magnets at the ALS," in *Proceedings of the IEEE Particle Accelerator Conference* (Washington, D.C., 1993); LBL-33227a (1993).
- T. Swain and R. DiGennaro, "Engineering high heat flux substrates for optical systems at the ALS," in *Proceedings of the International Symposium on Optical Applied Science and Engineering* (San Diego, CA, 1993); LBL-33214a (1993).
- J. Tanabe, J. Krupnick, and A. Paterson, "Magnet costs for the Advanced Light Source," in *Proceedings of the IEEE Particle Accelerator Conference* (Washington, D.C., 1993); LBL-33254a (1993).
- B. Taylor, C.C. Lo, K. Baptiste, J. Guigli, and J. Julian, "The ALS storage ring RF system," in *Proceedings of the IEEE Particle Accelerator Conference* (Washington, D.C., 1993); LBL-33291a (1993).
- V. Valdes, W. McKinney, and C. Palmer, "The differential method for grating efficiencies implemented in mathematica," 8th National Conference on Synchrotron Radiation Instrumentation (Gaithersburg, MD, 1993); LBL-34543 (1993).
- G.E. van Dorssen, H. A. Padmore, and W. Joho, "The optimization and comparison of multipole wiggler and bending magnet sources of synchrotron radiation for x-ray experiments," International Symposium on Optical Science and Engineering (San Diego, CA, 1993).

- C. Wang, "Monte Carlo calculations of multi-electron effects on synchrotron radiation," in *Proceedings of the International Symposium on Optical Applied Science and Engineering* (San Diego, CA, 1993); LBL-33355a (1993).
- C. Wang, S. Marks, and B. Kincaid, "Calculated radiation spectrum of ALS U5.0 undulator based upon magnetic measurements," in *Proceedings of the IEEE Particle Accelerator Conference* (Washington, D.C., 1993); LBL-33235a (1993).
- C. Wang and R. Schlueter, "Optimization of circularly polarized radiation from an elliptical wiggler, asymmetric wiggler, or bending magnet," 8th National Conference on Synchrotron Radiation Instrumentation (Gaithersburg, MD, 1993); LBL-34533 (1993).
- C. Wang, R. Schlueter, E. Hoyer, and P. Heimann, "Performance of the ALS elliptical wiggler," *Nucl. Instrum. Meth.* (in press); 8th National Conference on Synchrotron Radiation Instrumentation (Gaithersburg, MD, 1993); LBL-34547 (1993).
- A. Young, K.J. Bertsche, D.J. Clark, K. Halbach, W.B. Kunkel, K.-N. Leung, C.Y. Li, R.D. Schlueter, and M.E. Stuart, "Development of a compact permanent magnet cyclotron for accelerator mass spectroscopy," in *Proceedings of the IEEE Particle Accelerator Conference* (Washington, D.C., 1993); LBL-33310 (1993).
- Y. Zheng, Z. Hussain, and D.A. Shirley, "The influence of calculated phase shifts on the precision and accuracy of ARPEFS-derived structural parameters," *Chem. Phys. Lett.* **206**, 161 (1993); LBL-33370 (1992).
- Y. Zheng, E. Moler, E. Hudson, Z. Hussain, and D.A. Shirley, "Structural determination of NH₃ adsorbed on Ni(100) using angle-resolved photoemission extended fine structure," *Phys. Rev. B* **48**, 4760 (1993); LBL-33831 (1992).

ALS Advisory Panels

Two committees provide advice on ALS planning and operation to the LBL Director. The Science Policy Board provides advice on high-level policy issues affecting the ALS. The Program Review Panel gives advice on the scientific program through the ALS Director. Until the research program by independent investigators begins in earnest, this panel's main task will continue to be evaluation of PRT proposals and reviews of progress by previously approved PRTs. Accordingly, the panel devoted its 1993 meetings to proposals from both insertion-device and bend-magnet teams and to discussions of guidelines for PRT progress.

ALS Science Policy Board, 1993

Dean E. Eastman, IBM Thomas J. Watson Research Center (chair)
E. Morton Bradbury, School of Medicine, University of California at Davis
William F. Brinkman, AT&T Bell Laboratories
John C. Browne, Los Alamos National Laboratory
Bernd Crasemann, University of Oregon
J. McEwan Paterson, Stanford Linear Accelerator Center

ALS Program Review Panel, 1993

Neville V. Smith, AT&T Bell Laboratories (chair)
Franco Cerrina, University of Wisconsin-Madison
Charles S. Fadley, University of California at Davis and LBL
John W. Hepburn, University of Waterloo, Ontario, Canada
Franz J. Himpsel, IBM Thomas J. Watson Research Center
Christof Kunz, University of Hamburg
Gerald J. Lapeyre, Montana State University
William Orme-Johnson, Massachusetts Institute of Technology
François Wuilleumier, University of Paris-South, France

Advanced Light Source

1993 Staff Members

Management

B.M. Kincaid
G. Behrsing*
B. Feinberg
J. Krupnick*
A. Robinson
R. Yourd*
J. Zelter

Scientific Program Development

A. Schlachter
J. Cross††

Environment, Health and Safety

H. Collins**
P. Johnson**
R. Jones
G. Perdue**

Accelerator Systems

A. Jackson
R. Alvis
W. Barry
J. Byrd
J. Corlett
E. Forest
J. Johnson
R. Keller
C. Kim
K.-J. Kim
G. Krebs
B. Kuske
P. Kuske
G. Lambertson
W. Leemans
D. Mazzoletti
M. Meddahi
H. Nishimura
L. Schachinger
F. Selph
F. Voelker*

Accelerator Operations

R. Miller
D. Bentsen
R. Brokloff
W. Byrne
S. Daly
C. Hauck
O. Jones
J. Pusina
R. Thatcher
M. Wolfe

Experimental Systems

H. Padmore
D. Chen
D. Cheng
E. Chow
P. Greene
K. Halbach*
P. Heimann
M. Howells

P. Hopstone
Z. Hussain
S. Irick*
E. Judd
R. Kaza
S. Marks*
W. McKinney
M.E. Melczer
D. Mossessian
R.C.C. Perera
A. Saffarnia
R. Schlueter*
S. Turek
V. Valdez
G. Visser
C. Wang
A. Warwick

Electrical Systems*

H. Lancaster
B. Bailey
M. Balagot
K. Baptiste
J. Bishop
K. Bolin
W. Brown
J. Buchanan
R. Candelario
G. Carmignani
M. Chin
C. Cork
T. Downs
F. Duarte
M. Fahmie
D. Fong
K. Fowler
R. Gassaway
R. Gervasoni
A. Geyer
J. Gregor
E. Henson
J. Hinkson
B. Holmes
T. Jackson
J. Johnston
L. Jordan
J. Julian
A. Kruser
A. Lindner
C.C. Lo
K. Luchini
I. Lutz
S. Magyary
M. McEvoy
P. Molinari
R. Mueller
M. Nolan
D. Oldfather
F. Ottens
E. Perry
D. Peterson
M. Photos
G. Portmann
G. Potter
A. Ritchie
G. Ritscher

F. Rogers
A. Robb
J. Sopher
G. Stover
S. Stricklin
M. Szajbler
B. Taylor
C. Timossi
K. Woolfe
J. Young
J. Zelter
J. Zukowski

Electricians†

D. Adams
K. Gray
T. Mullarky
W. Nelson
G. Peterson
J. Phillips
G. Reis
D. Sandler
J. Schultz

Mechanical Systems*

A. Paterson
S. Abbott
J. Akre
D. Anderson
N. Andresen
G. Andronaco
R. Armstrong
B. Avery
B. Baldock
A. Black
A. Boynton
D. Calais
M. Calvisi
J. Carrieri
A. Catalano
B. Caylor
J. Chin
M. Coleman
D. Colomb
C. Cummings
D. Davis
M. DeCool
R. DeMarco
D. DiGennaro
R. Duarte
M. Dycus
D. Ellis
K. Franck
A. Gavidia
B. Gee
D. Gibson
M. Gonzalez
J. Guigli
T. Henderson
E. Hoyer
D. Hull
D. Humphries
C. Jones
D. Jones
R. Jones
N. Kellogg

K. Kennedy
H. Krapf
M. Kritscher
T. Lauritzen
C. Lawrence
J. Leifheit
A. Lim
A. Lobodovsky
I. Lomax
B. Lott
R. Low
W. Low
A. Lunt
B. MacDonell
C. Matuk
P. McKean
J. Meneghetti
D. Merrill
V. Moroz
G. Morrison
W. Oglesby
J. Osborn
D. Plate
D. Reimers
M. Reimers
K. Rex
J. Rounds
B. Rude
R. Schlueter
K. Sihler
T. Swain
J. Tanabe
L. Tateo
J. Thomson
R. Wampler
E. Wong
W. Wong
D. Yee
N. Yu
F. Zucca

Conventional Facilities**

J. Pickrell
R. Baker
L. Chan
W. Lopez
R. Shilling
T. Yuen

Administrative Support

J. MacDonald
E. Saucier
E. Atkin
S. Butler
J. Carlin
K. Erickson-Weber
S. Fujimura
W. Guillbeau
J. Minton
J. Pfeiffer*
A. Tidwell
G. Ureta
G. Vierra
K. Williams

* Engineering Division

†† Plant Engineering Department

† Construction and Maintenance Department

** Environment, Health and Safety Division

†† Technical Information Department

ALS Administration

Advanced Light Source, MS 80-101
Lawrence Berkeley Laboratory
University of California
Berkeley, CA 94720
Tel: (510) 486-4257
Fax: (510) 486-4960

ALS Administrator

Elizabeth Saucier
Tel: (510) 486-6166
Fax: (510) 486-4960
Email: ecsaucier@lbl.gov

ALS Director

Brian M. Kincaid
Tel: (510) 486-4810
Fax: (510) 486-4960
Email: bmkincaid@lbl.gov

ALS User Liaison

Alfred S. Schlachter
Tel: (510) 486-4892
Fax: (510) 486-7696
Email: fred@lbl.gov

DISCLAIMER

This document was prepared as an account of work sponsored by the United States Government. While this document is believed to contain correct information, neither the United States Government nor any agency thereof, nor The Regents of the University of California, nor any of their employees, makes any warranty, express or implied, or assumes any legal responsibility for the accuracy, completeness, or usefulness of any information, apparatus, product, or process disclosed, or represents that its use would not infringe privately owned rights. Reference herein to any specific commercial product, process, or service by its trade name, trademark, manufacturer, or otherwise, does not necessarily constitute or imply its endorsement, recommendation, or favoring by the United States Government or any agency thereof, or The Regents of the University of California. The views and opinions of authors expressed herein do not necessarily state or reflect those of the United States Government or any agency thereof, or The Regents of the University of California.

Available to DOE and DOE Contractors
from the Office of Scientific and Technical Information
P.O. Box 62,, Oak Ridge, TN 37831
Prices available from (615) 576-8401

Available to the public from the
National Technical Information Service
U.S. Department of Commerce
5285 Port Royal Road, Springfield, VA 22161

Lawrence Berkeley Laboratory is an equal opportunity employer.

Editor: Jane Cross
Writer: Ron Fielder
Art Director and Designer: Marilee Bailey • Paula Laguna
Design and Layout: Alice Ramirez
Photography: LBL Photo Lab

**Lawrence Berkeley Laboratory
Advanced Light Source
University of California
Berkeley, California 94720**