

Lawrence Berkeley National Laboratory

Recent Work

Title

LARGE DIAMETER THIN SUPERCONDUCTING SOLENOID MAGNETS

Permalink

<https://escholarship.org/uc/item/2fx3k95d>

Author

Green, Michael A.

Publication Date

1976-10-01

LARGE DIAMETER THIN SUPERCONDUCTING
SOLENOID MAGNETS

Michael A. Green

October 1976

Prepared for the U. S. Energy Research and
Development Administration under Contract W-7405-ENG-48

For Reference

Not to be taken from this room

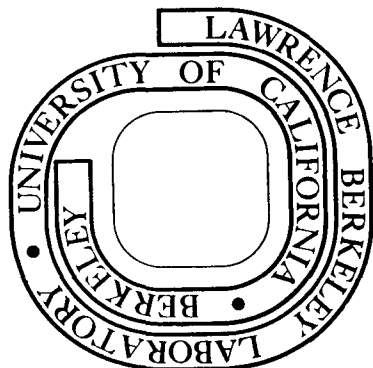

DISCLAIMER

This document was prepared as an account of work sponsored by the United States Government. While this document is believed to contain correct information, neither the United States Government nor any agency thereof, nor the Regents of the University of California, nor any of their employees, makes any warranty, express or implied, or assumes any legal responsibility for the accuracy, completeness, or usefulness of any information, apparatus, product, or process disclosed, or represents that its use would not infringe privately owned rights. Reference herein to any specific commercial product, process, or service by its trade name, trademark, manufacturer, or otherwise, does not necessarily constitute or imply its endorsement, recommendation, or favoring by the United States Government or any agency thereof, or the Regents of the University of California. The views and opinions of authors expressed herein do not necessarily state or reflect those of the United States Government or any agency thereof or the Regents of the University of California.

LARGE DIAMETER THIN SUPERCONDUCTING
SOLENOID MAGNETS*Michael A. Green[†]Lawrence Berkeley Laboratory
University of California
Berkeley, California 94720

October 1976

Abstract

High energy physics experiments on the latest generation colliding beam machines require large superconducting solenoid magnets. The Lawrence Berkeley Laboratory is developing a new generation of high current density ($\sim 10^9 \text{ Am}^{-2}$) superconducting solenoid magnets which are thin from a radiation standpoint. In order to meet our design objectives, an integrated magnet and cryostat design has evolved. Recent test of one meter diameter prototype magnets show that our design concepts are technically viable. The results of the one meter magnet test are reported here.

* This work was performed by the U.S. Energy Research and Development Administration.

[†] The author is with the University of California - Lawrence Berkeley Laboratory, Berkeley, California, U.S.A. 94720.

A new generation of superconducting solenoid magnets is under development at the Lawrence Berkeley Laboratory. This development is prompted by a need for large superconducting solenoids which are thin from a radiation standpoint. These magnets would be used on one or more of the high energy physics experiments on the electron-positron colliding beam facility called PEP, which is now under construction at the Stanford Linear Accelerator Center in the United States.¹ The development of thin superconducting solenoids is also of interest to physicists who are designing experiments for use on the Intersecting Storage Rings (ISR) at CERN and the PETRA machine now being built in Hamburg, Germany.

Experiments being proposed for PEP require a solenoid which is about 2 meters in diameter with length between iron poles of about 4 meters. The design central induction for these magnets will be approximately 1.5 T (see Fig. 1). The proposed experiments require that physics be done outside the magnet coil in a relatively field-free region as well as inside the solenoid.² Thus the radiation thickness of the solenoid magnet and cryostat must be minimized. Conventional cryogenically stabilized solenoids cannot be used because of their high radiation thickness.

A Conceptual Design

Experiments being proposed suggest that the thin superconducting solenoid magnet system be as thin as possible. A compromise may be around one third of a radiation length. (One radiation length of material will convert just over 60 percent of gamma rays passing through the material to charged particle pairs.) Table 1 shows that

desirable materials from a radiation thickness standpoint have a low atomic number and a low density.³ Unfortunately, niobium-titanium has neither of these properties. Since the radiation thickness of the magnet system includes the coil, the coil form, and the cryostat, less than 40% of the radiation thickness of a third radiation length thick solenoid can be the superconductor. Therefore, the maximum superconductor thickness is 2.2 mm. One finds that the minimum current density in the superconducting matrix for a thin coil, (1/3 radiation length total magnet system thickness) 1.5 T magnet will be $0.54 \times 10^9 \text{ Am}^{-2}$. Most practical magnet designs call for superconductor matrix current densities of 0.8 to $1.0 \times 10^9 \text{ Am}^{-2}$.

A 4 m long, 2 m diameter, 1.5 T solenoid bounded by iron poles will have a stored energy larger than 10 MJ. This size and stored energy is well beyond the state of the art for a magnet with superconductors which operates at current densities of 10^9 Am^{-2} or more. Figure 2 shows the superconductor matrix current density versus stored energy for a number of magnets built in the last 15 years. The figure shows that magnets which operate at high superconductor current densities have low stored energies and vice-versa. Magnets which have been built to date fall in two broad categories: the intrinsically stable magnets which have a stored energy under 2 MJ and the cryogenically stable magnets which have high stored energies. The large circles which are crosshatched show the progress made to date by LBL. The large open circles show test magnets which are under construction and the proposed PEP detector magnet. It is clear from Fig. 2 that the large LBL test magnets and the proposed PEP detector magnet must operate at current densities well beyond the state of the art.

Cryogenically stable magnets do not quench (dump their magnetic energy suddenly when a portion of the superconductor turns normal). Hence this safe method of stabilization has been used on all of the large magnets built to date. Intrinsically stable magnets, which use a twisted multifilament superconductor, will quench when a portion of the superconductor becomes normal. The propagation of the normal region determines whether or not the magnet can be quenched without burning up the coil. The larger the stored energy and superconductor current density, the worse the burnout problem becomes.

The key problem to be solved in large thin solenoids is the quench protection problem. Most magnet designers solve this problem by dumping most of the magnet energy into an external resistor. The dump resistor approach alone does not work in high-current-density magnets for the following reasons: 1) when the external resistance is high enough to remove an appreciable amount of magnetic energy, the transient voltages in the system are excessive; 2) the current is not reduced quickly enough to prevent burnout; 3) the dump resistor requires quench detection and switching; the system may not be safe enough.

The second problem which faces all large-magnet builders is the cryogenic cooling problem. The cryogenic system design becomes more difficult if the magnet can quench. Large magnets, which are usually cooled by a bath of liquid helium, are difficult to cool down from room temperature to liquid helium temperature.

The LBL design solves the quench protection problems and cryogenic systems problem in a single integrated package. The LBL thin solenoid consists of three primary parts: 1) the thin coil (the superconductor), 2) a low resistance, low radiation length, bore tube closely coupled to the coil, and 3) a tubular cooling system carrying pumped two-phase helium at 4.6°K. The three parts of the magnet are cast together into a single rigid unit with a radiation thickness less than 0.25 radiation lengths. (The cryogenic vacuum vessel is the remainder of the radiation thickness.)

The low resistance bore tube, which is inductively coupled to the coil, is the key to quench protection in a large high-current-density solenoid magnet. The closely coupled bore tube behaves like a shorted secondary in a transformer; therefore:

- 1) Increasing resistance of the coil as the normal region propagates causes the current in the coil to shift to the bore tube. This reduction of the coil current reduces the hot spot temperature in the coil.
- 2) The bore tube can absorb a substantial amount of the magnet's stored energy during a quench.
- 3) Since the coil current is quickly reduced, transient voltages within the coil are reduced during a quench.
- 4) The bore tube causes the entire magnet to go normal before the quench is entirely propagated. We call this phenomenon "quench back."

In summary, the well-coupled low resistance bore tube controls the quench process in a fail-safe manner, in contrast with the external-resistor technique. Therefore, there is less dependence on electronics or switches.

Since one must use an intrinsically stable superconductor, one is not restricted to a bath cooling system. Intrinsically stable superconductor (in a d.c. magnet) does not care how it is cooled as long as it is cold. A tubular cooling system carrying two-phase helium will provide all of the cooling that is needed. The tubular cooling system will avoid the major problems which are encountered in many large magnet cryogenic systems. The advantages of the tubular cooling over an ordinary bath-cooled system are:

- 1) The cool-down of the magnet is well controlled because the helium flows through the magnet in a well-defined path.
- 2) The mass and radiation thickness of the tubular cooling system is less than a conventional bath cryostat.
- 3) The amount of helium in direct contact with the magnet coil is minimized. Helium boil-off during a quench is orderly and well controlled.

Two-phase helium has been chosen over supercritical helium as a coolant for the following reasons: 1) A two phase "boiling" helium system will operate at lower temperatures than a supercritical helium system. 2) The mass flow for a given amount of refrigeration is lower for the two-phase helium system. 3) The boiling two-phase system can transfer large local heat fluxes without changing appreciably the temperature of the helium stream.

The One Meter Diameter Test Coils

Two 1 m diameter test solenoids were built at LBL.⁴ The inside diameter of the magnets is 1021 mm; magnets are 500 mm long; thickness of the magnets with their tubular cooling system is 24.5 mm. The two test solenoids have very nearly identical physical parameters. The primary difference between the two magnets is the copper to superconductor ratio of the superconductor.

The characteristics of the superconductors used in the two test coils are shown in Table 2. Both superconductors have a formvar insulation which is 0.05 mm thick. The superconductor was wound on low resistance bore tubes fabricated from 6.35 mm thick 1100-aluminum plate. Two layers of superconductor were wound on the bore tube. A winding pre-tension of 130 N was applied to the superconductor so that the thermal contraction between the coil and bore tube was matched. Layer to layer and layer to ground insulation was provided by 0.35 mm of impregnated glass tape. An aluminum cooling tube 117 m long with an outside diameter of 12.7 mm was wound on top of the coil. The space between the tubes was filled with polyester braid. The whole assembly was vacuum cast in epoxy to form a single unit. A cross section of the magnet is shown in Fig. 3. Figure 4 is a photograph of the complete B magnet. The physical and electrical properties of the two test coils are shown in Table 3.

Refrigeration System Tests

A recent test of the LBL 1 m diameter magnets was made with the two magnets connected to the same refrigeration circuit. The assembly of the two magnets, which are connected in series, is shown in Fig. 5. The magnets could be tested electrically either individually or with both magnets in series. The tubular cooling system was supplied with two-phase helium from a CTi Model 1400 refrigerator. A schematic of the refrigeration system is shown in Fig. 6. The magnet and control cryostat are connected by a 9 m long flexible transfer line. The refrigerator compressor pumps the helium through the magnet cooling circuit. The control cryostat serves as a liquid helium collection point. The quality of the helium entering the magnet is reduced by heat exchanging with the liquid helium in the control dewar.⁵

Tests of the two magnets indicate that the tubular cooling system will operate on a closed cycle refrigerator. The CTi Model 1400 refrigerator used for the test is capable of delivering 55 W at 4.5°K, or it will liquify helium gas at the rate of 0.54 gs^{-1} . The measured refrigeration liquefaction coefficient for the refrigerator running at high refrigeration loads (90 rpm engine speed) was 125 Jg^{-1} (4.4 W per liter per hour).

The refrigerator cooled the magnets down (the cold mass of the system was around 220 kg) and was able to refrigerate the magnets with plenty of excess capacity. The mass flow through the magnet cooling tubes increased as their temperature decreased (see Fig. 7). The pressure drop across the 235 m of cooling tube decreased with temperature (see Fig. 8). When the magnet temperature reached 5.3°K

(just above the critical temperature) the pressure drop was about 0.2 bar. The onset of two-phase flow was announced by a dramatic decrease in pressure drop (at least a factor of 2) across the magnets. As the heat exchanger became covered by liquid helium the pressure drop leveled off below 0.05 bar when the mass flow through the magnet was 4 gs^{-1} .

The average operating temperature of the two magnets was 4.6°K (as measured by silicon diode thermometers). The estimated heat leak into the cryogenic system (including control dewar and transfer line) was 10 W. The three 1000 A electrical leads required 0.18 gs^{-1} of gas flow. The refrigerator was able to refrigerate the magnet, provide gas for the electrical leads, and liquefy 0.27 gs^{-1} of helium into the control cryostat. Steady state operation of the two-phase cooling system was smooth. There was no evidence of flow oscillations in the cooling system.

The refrigeration system was operated when the load exceeded the refrigerator output. During steady state operation, with the liquid level in the control dewar dropping, a magnet temperature of $4.6\text{-}4.8^\circ\text{K}$ was maintained even though there was insufficient refrigeration. The magnet temperature did not increase until the helium which covered the heat exchanger had boiled away.⁶

The tubular cooling system was well behaved during a magnet quench. The 235 m of cooling tube in the two magnets contained about 20 liters of liquid helium. Since the heat transfer from the coil and bore tube is poor, the pressure buildup in the cooling tube took 10 or 15 seconds. Peak transient pressures of 14 bar were

measured in the cooling tubes. The time required for the system to recover from a quench depended on magnet stored energy released into the coil and bore tube. Recovery times varied from 1 to 20 minutes.

Magnet Performance Tests

The A and B magnets were tested by an LBL team of engineers and physicists lead by P. Eberhard, J. Taylor and the author. Quenches were induced by discharging a 1000 μF capacitor into small (10 mm diameter) quench coils. The magnetic field pulse created by these coils turns a small region of the magnet normal. The pulse of the quench coil provides a time mark for the quench process. Electrical data, such as the magnet current and the voltage generated in a coil which measured $d\phi/dt$, were recorded on pictures of a storage oscilloscope screen.⁷ The pictures were measured and the digital information was then processed on the computer.

Quench tests were made in graduated steps with quenches being induced at low currents first.⁸ This procedure was followed in order to get as much experimental data as possible before the coil might be destroyed. Both magnets were operated at current densities in excess of 10^9 Am^{-2} without apparent damage. The quench tests yielded the following information: 1) quench propagation velocities were estimated; 2) a shift in the current from the coil to the bore tube was measured; and 3) quench back from bore tube back to superconducting portions of the coil was demonstrated. In addition to quench tests, strain measurements on the bore tube of two coils were made. Training or lack of it can be correlated with these measurements of strain.

The LBL quench tests showed that the coil resistance (the normal region size) grew as time squared early in the quench process. Quench velocities as high as 35 ms^{-1} were measured along the wire. Quench velocities along the wire as a function of matrix current density are shown in Fig. 9. In the early portion of the quench, the functional relationship between quench wave velocity and current density is in general agreement with theory. The estimated quench velocities agree with the theoretical values better than a factor of 2.

The quench tests demonstrated the viability of the coupled bore tube, and also demonstrated that the magnet current is shifted into the bore tube as the coil goes normal. Figure 10, which is a plot of the magnetic flux due to the coil current, bore tube current, and total current, shows that early in the quench process the current shifts from the coil to the bore tube while the total flux remains relatively unchanged.

Figure 11 shows the normalized coil current I/I_0 as a function of time for various starting currents I_0 in the B magnet. All of the curves except for the 100 A curve show a break where the current in the coil suddenly drops. This is the "quench back" process when the entire coil quickly becomes normal. Quench back divides the quench process into two distinct periods. The first period is characterized by the quadratic increase in coil resistance described previously. The coil current drops while the bore tube current increases. The first period (Period 1) ends with the sharp bore tube current increase (or sharp coil current decrease) we call "quench back."

Quench back usually starts when the coil current drops to about 70% of its starting value. Before quench back, only a fraction of the coil winding is normal. Heat from resistive heating in the bore tube drives the rest of the coil normal. (It should be noted that the shift in the magnetic field in the coil could cause quench back at high currents in the coil.) After quench back, when the coil is entirely normal, the second period starts. This period, called Period 2, is characterized by a roughly exponential current decay in both the coil and the bore tube (see Fig. 10).¹⁰

Figure 12 shows the quench-back time as a function starting current in the A and B magnets. The band between the upper and lower curves represents the time over which the coil becomes entirely normal through the quench back process. The A magnet requires more time to quench back than does the B magnet. An explanation for this is that normal resistance per unit length is greater for the B magnet conductor than for the A magnet conductor. Quench back apparently occurs when the magnet coil resistance reaches a specific value. The B magnet reaches this value sooner than the A magnet. When the B magnet had normal regions induced at more than one point, the quench back time was reduced. When the A and B magnets were hooked in series the quench back time was longer than for either of the magnets alone. This suggests that $d\phi/dt$ had to reach a certain value in order to induce enough current in the bore tube to drive the rest of the magnet normal.

The duration of Period 1, the time before quench back, is important for hot spot formation within the coil. The length of Period 1 was found to decrease as the starting current to the $3/2$ power. The temperature which a coil hot spot reaches is a function of the integral of the current density squared with time.⁸ It is important that coil current decay quickly in a high-current-density magnet. Since quench back is an important part of the process of dumping the coil current, it is important to minimize the quench back time.

Since there is a marked shift in current from the coil to the bore tube, much of the magnet energy will end up in the bore tube. The amount of energy which ends up in the bore tube is a function of the current decay time constants for the coil and the bore tube. For example, at a current of 700 A in the A magnet 73% of the magnetic energy was deposited in the bore tube. The bore tube current decay time constant is a factor of 3 to 4 longer than the coil time constant for this magnet. In general, it was found that more of the magnetic energy ended up in the bore tube at high initial currents than at low currents.

The training of the two magnets was quite different. The B magnet which was tested only once, exhibited no training as the coil was changed to various currents up to 920 A (the limit of the power supply we were using). The A magnet which had been tested three times has trained during the last two tests. The first test may have had some training but we are not sure. (The refrigeration system was troublesome during the first test of the A magnet.) Training quenches occurred at currents of 597, 654, 696, 733, and 773 A during the second

test of the A magnet. The third test of A magnet had only one training quench at 804 A. Training in the A magnet is apparently caused by movement of the superconductor within the magnet due to a broken epoxy bond between the bore tube and the coil. Strain gage measurements on the A magnet bore tube showed that a portion of the coil moved away from the bore tube as magnetic stresses were applied. The B magnet, which exhibited no training, showed no evidence of coil separation from the bore tube. Future LBL thin solenoids will be designed to prevent movement of the coil away from the bore tube.

The two LBL 1 m test coils both operated at current densities in excess 10^9 Am^{-2} . The B magnet was quenched when its stored magnetic energy approached a third of a megajoule (see Table 3). Both 1 m test magnets operated at current densities far above what is normal for magnets of their stored magnetic energy (see Fig. 2). We conclude that the concept of the well-coupled low resistance bore tube worked as expected. The experimental evidence gained has aided the design of the 2 m test magnet.

The Two Meter Test Coil

One or two more test solenoids will be built before the PEP detector magnet is built. At least one of these magnets will have a diameter of 2 m. Our LBL team has decided to incorporate two features not found in the 1 m diameter coils: 1) There will be longitudinal quench propagaters built within the magnet coil to increase the turn-to-turn quench velocity. Quench propagation turn-to-turn in theory

can be made as fast as quench propagation along the superconductor.

Thus the resistance of the coil will grow much faster.

2) There will be a support member built into the coil to prevent coil movement away from the bore tube in the event the epoxy bond is broken. In addition we intend to pursue the development of magnets using aluminum based conductors and other materials which have a low radiation thickness. (For example, one could use a magnesium bore tube, magnesium cooling tubes, and a boron fiber composite support system.)

Other methods of quench control will be considered. The LBL experiments show the importance of dumping the current in the coil quickly. The low resistance bore tube is the key to this process. Our team is investigating two other methods of speeding up the quench back process in addition to the longitudinal quench propagaters. They are: 1) small quench coils are scattered about the magnet and induce many normal regions into the magnet simultaneously; 2) a dump resistor is put across the leads, putting $d\phi/dt$ into the magnet to drive enough current into the bore tube in order to cause early quench back. The low resistance bore tube causes the current in the coil to decrease rapidly. Both of the methods mentioned previously require the development of a reliable quench detection system.

Summary

Our team at the Lawrence Berkeley Laboratory has demonstrated that large thin solenoids can be refrigerated with a two-phase helium tubular cooling system. These magnets have operated at high superconducting matrix current densities up to $1.17 \times 10^9 \text{ Am}^{-2}$. At this current density the magnet stored energy was 312 kJ.

It is now felt that high current density solenoids with stored energies in excess of 10 MJ can be built using the technology now under development at LBL. The use of high current density, tubular cooled solenoid magnets could extend far beyond high energy physics. Such magnets may eventually find their way into magnetic separators, or magnets for space application due to the light weight of the magnet coil. Integration of the coil, bore tube and cryogenic system into a single unit is an important step toward developing a reliable superconducting magnet system.

Acknowledgment

This paper would not have been possible without the efforts of P.H. Eberhard, J.D. Taylor, W. Michael, W.A. Wenzel and many others at the Lawrence Berkeley Laboratory. I am deeply indebted to all of the people who have supported the development of thin solenoids at the Laboratory. The efforts of D. Andrews of Cornell are greatly appreciated.

References

1. Lobkowitz, F., et al. General Users Magnet Design for PEP, in the 1975 PEP Summer Study Proceedings, pp. 46-75
2. Barbaro-Galtieri, A., et al. Report of the General Purpose Detector Group, in the 1975 PEP Summer Study Proceedings, pp. 108-115
3. Green, M.A., MINIMAG Experiment, Large Superconducting Solenoid Magnet, the Radiation Thickness of the Magnet and Its Cryostat, Lawrence Berkeley Laboratory Engineering Note M4835, UCID 3755, March 1975.
4. Green, M.A. and Taylor, J.D., PEP Detector Development, Large Superconducting Test Solenoid, Construction of the A Coil, Lawrence Berkeley Laboratory Engineering Note M4886, Dec. 1975.
5. Green, M.A., "The Large Superconducting Solenoid for the MINIMAG Experiment" (to be published in Advances in Cryogenic Engineering) Lawrence Berkeley Laboratory Report LBL-3677, July 1975.
6. Green, M.A., Eberhard, P.H., and Taylor, J.D., Large High Current Density Superconducting Solenoids for Use in High Energy Physics Experiments (to be published in the Proceedings of the 6th International Cryogenic Engineering Conference, ICEC-6) Lawrence Berkeley Laboratory Report LBL-4824, May 1976.
7. Eberhard, P.H., Gibson, G., and Taylor, J., Guidelines for Magnet Test, Lawrence Berkeley Laboratory Physics Note 818, Feb. 1976.

8. Eberhard, P.H., A Cautious Method of Testing Superconducting Magnets, Lawrence Berkeley Laboratory Physics Note 812, Dec. 1975.
9. Private communication with P. Turowski of the Institute für Experimentelle Kernphysik, Kernforschungszentrum Karlsruhe on Recent Quench Velocity measurements.
10. Eberhard, P.H., et al. Tests on Large Diameter Superconducting Solenoids Designed for Colliding Beam Accelerators (to be published in the Proceedings of the Applied Superconductivity Conference, IEEE Transactions section on Magnetics), Lawrence Berkeley Laboratory Report LBL-5364, Aug. 1976.

Table 1. The thickness of various materials for a radiation thickness of one radiation length

Material	Thickness for one radiation length (mm)
Helium (liquid)	7450.0
Epoxy-dacron	345.0
Epoxy-glass	183.0
Magnesium	145.0
Aluminum	90.0
Copper	14.5
Copper based superconductor Nb-Ti	15.6-16.2

* Copper to superconductor ratios vary from 2 to 1 to 1 to 1.

Table 2. The superconductor characteristics for the two LBL one meter solenoids

	Magnet A	Magnet B
Bare matrix diameter (mm)	0.99	1.00
Insulated matrix diameter (mm)	1.09	1.10
Copper to superconductor ratio	1.8	1.0
Number of filaments	2300	2700
Filament diameter (μm)	12.3	13.6
Filament twist pitch (mm)	~ 10	~ 10
Critical current (A) @4.2K,2T (defined as 10^{-14} Ωm resistivity)	900	1360

Table 3. Physical and electrical characteristic of the two LBL one meter solenoids

	A Magnet	B Magnet
Coil diameter (mm)	1035.0	1035.0
Coil length (mm)	461.0	464.0
Number of turns	835.0	832.0
Magnet self inductance (H)	0.75	0.74
Magnet design current (A)	700.0	880.0
Design current density in matrix (Am^{-2})	0.91×10^9	1.12×10^9
Stored energy at design current (J)	1.83×10^5	2.88×10^5
Peak current achieved in test (A)	804.0	920.0
Peak current density achieved in test (Am^{-2})	1.02×10^9	1.17×10^9
Peak stored energy (J)	2.42×10^5	3.12×10^5
Radiation thickness (radiation lengths)	0.24	0.24

Figure Captions

- Fig. 1 An exploded view of a colliding beam machine detector magnet showing the inner cryostat, coil, and outer cryostat.
- Fig. 2 The stored energy versus superconductor matrix current density for a number of magnets built since 1961.
- Fig. 3 A cross section of the LBL 1 m diameter solenoid coil.
- Fig. 4 The completed LBL magnet B showing the lead bus bar assembly.
- Fig. 5 The A and B solenoid magnets connected together for testing.
- Fig. 6 A schematic of the tubular cooling refrigeration system used for the LBL thin coil tests.
- Fig. 7 Helium mass flow from the CTi 1400 refrigerator as a function of average magnet temperature.
- Fig. 8 The pressure drop across the A and B magnet cooling coils (235 m of 10.8 mm inside diameter tube) as a function of average magnet temperature.
- Fig. 9 Quench propagation velocity as a function of matrix current density (the Karlsruhe data taken by P. Turowski⁹ shows a J^2 dependence. The sample was well cooled, retarding the velocity at low current).

- Fig. 10 Magnetic flux due to current in the coil, bore tube and the total magnetic flux as a function of time since the start of the quench in magnet A at a starting current of 700 A.
- Fig. 11 The normalized coil current versus time after quench start for various starting currents in magnet B.
- Fig. 12 Quench back time versus starting current in magnets A and B.

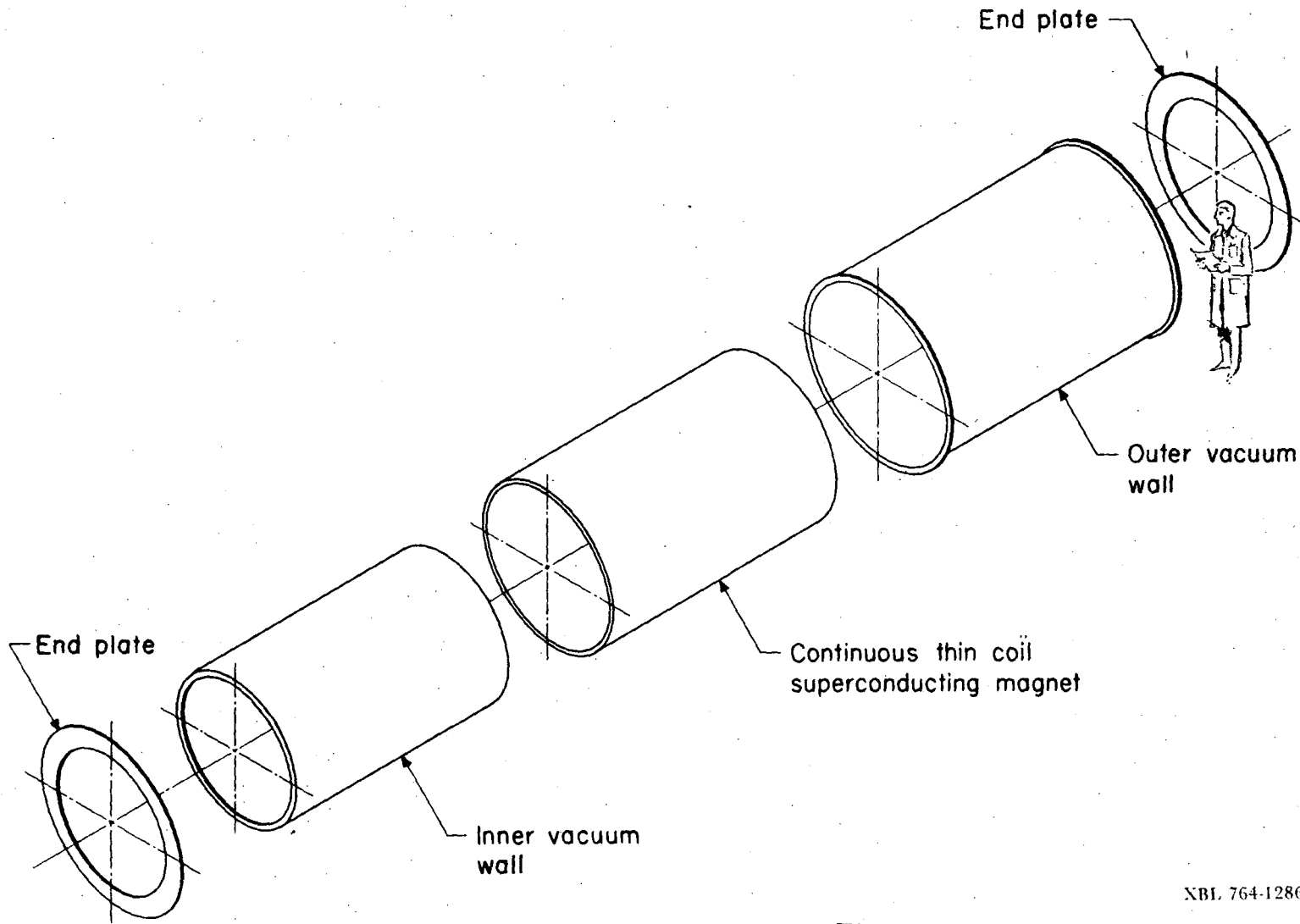
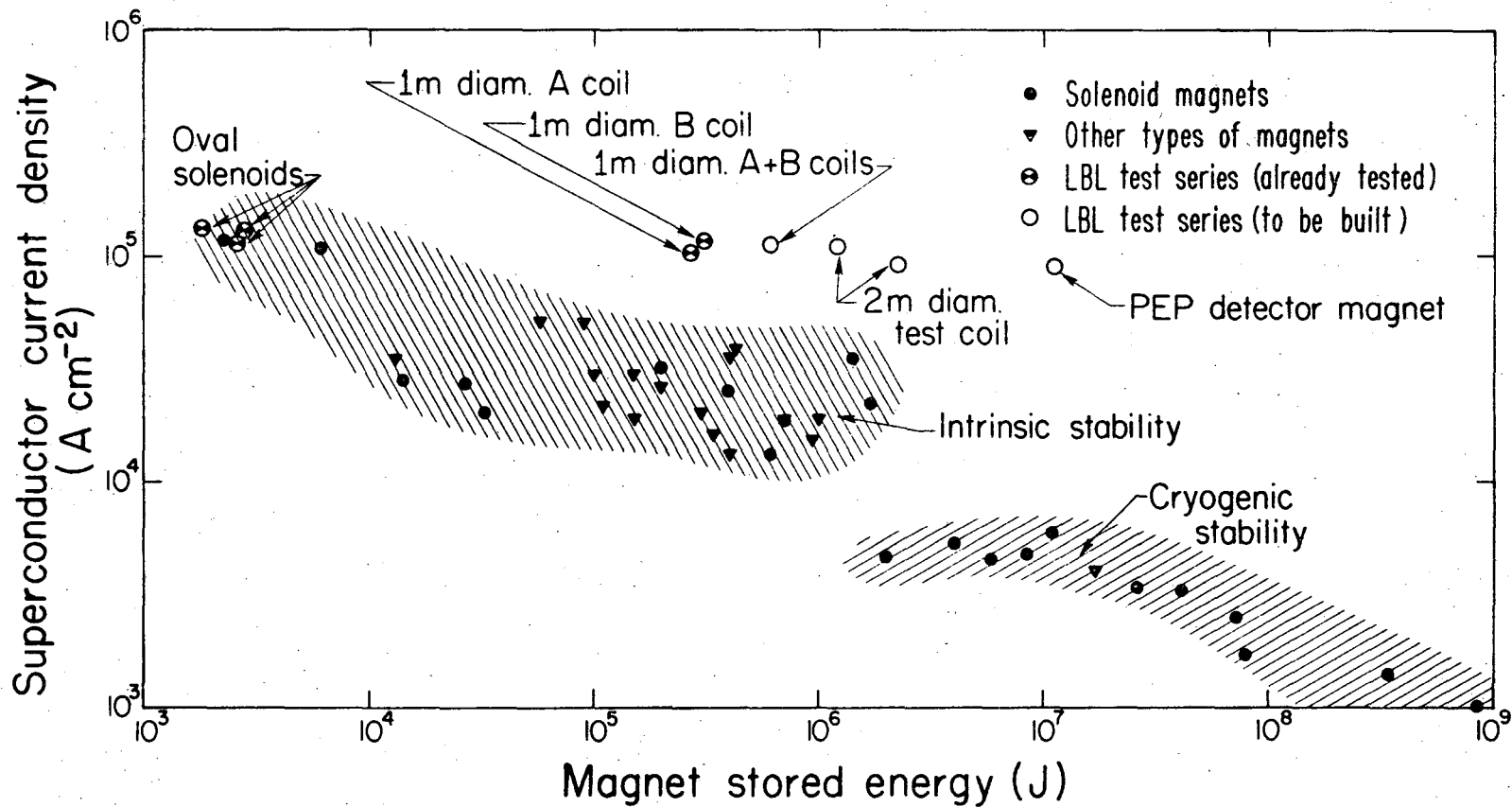

Fig. 1

XBL 764-1286



XBL 769 4017

Fig. 2

00004605262
-25-

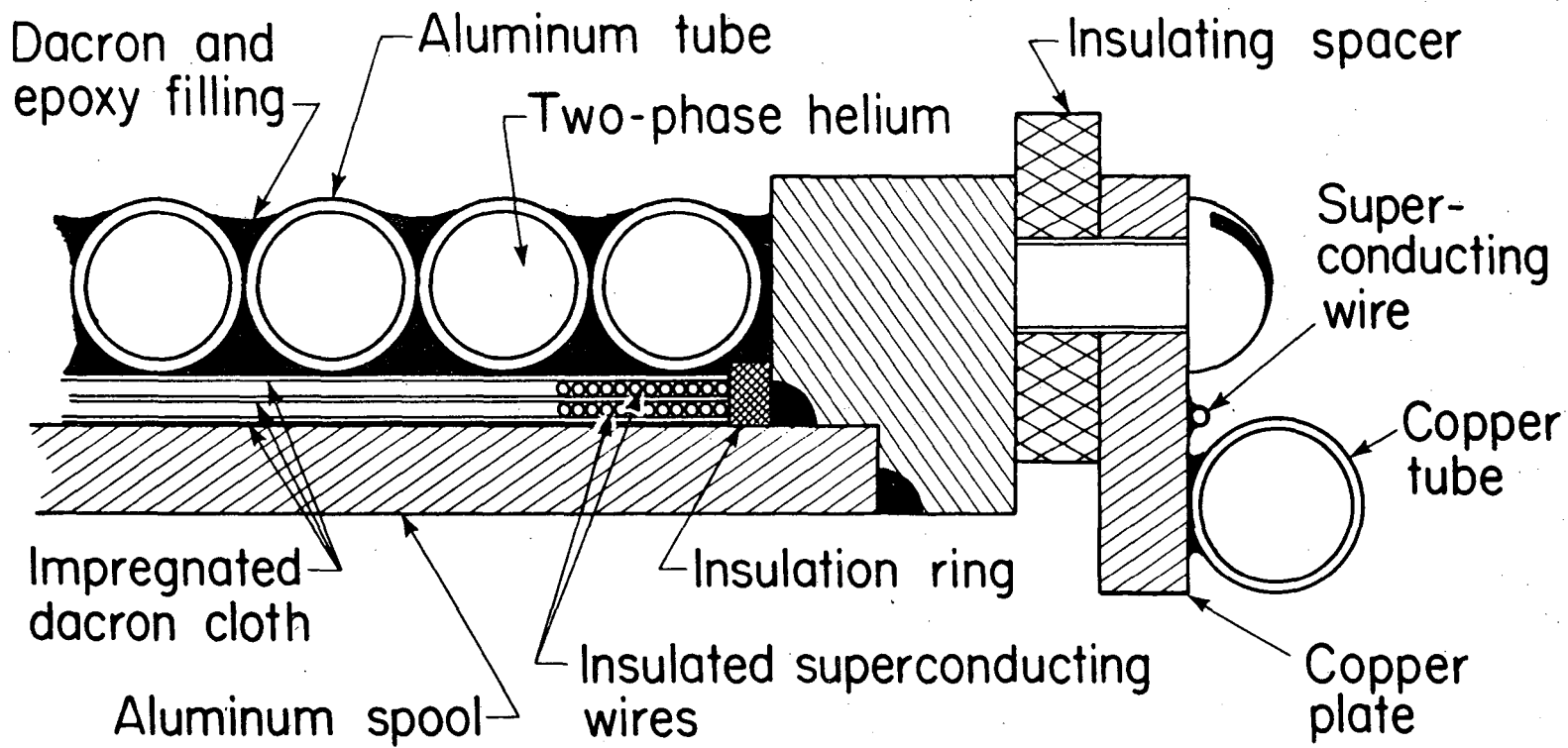

XBL 757-3453

Fig. 3

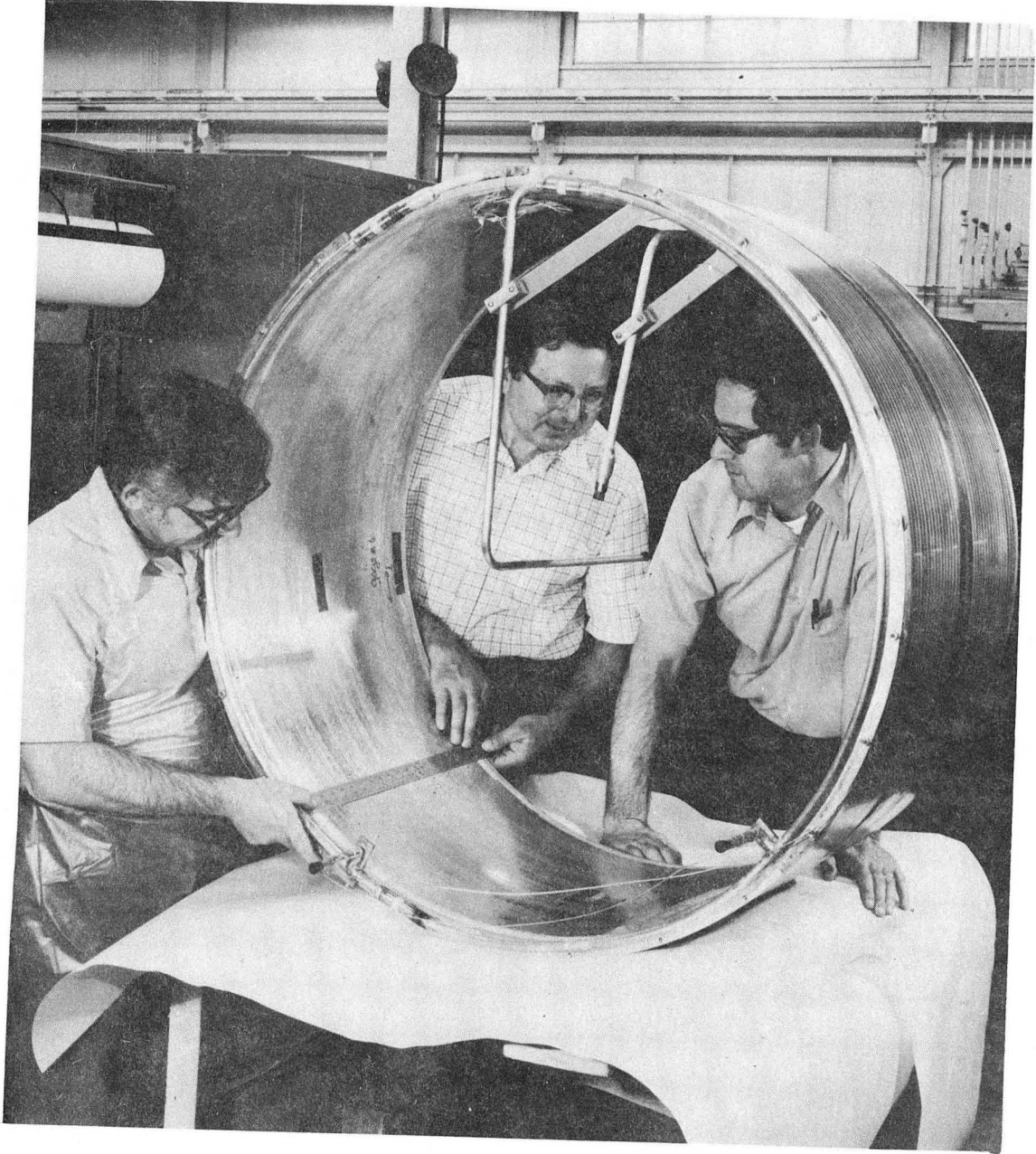

CBB 762-2054

Fig. 4

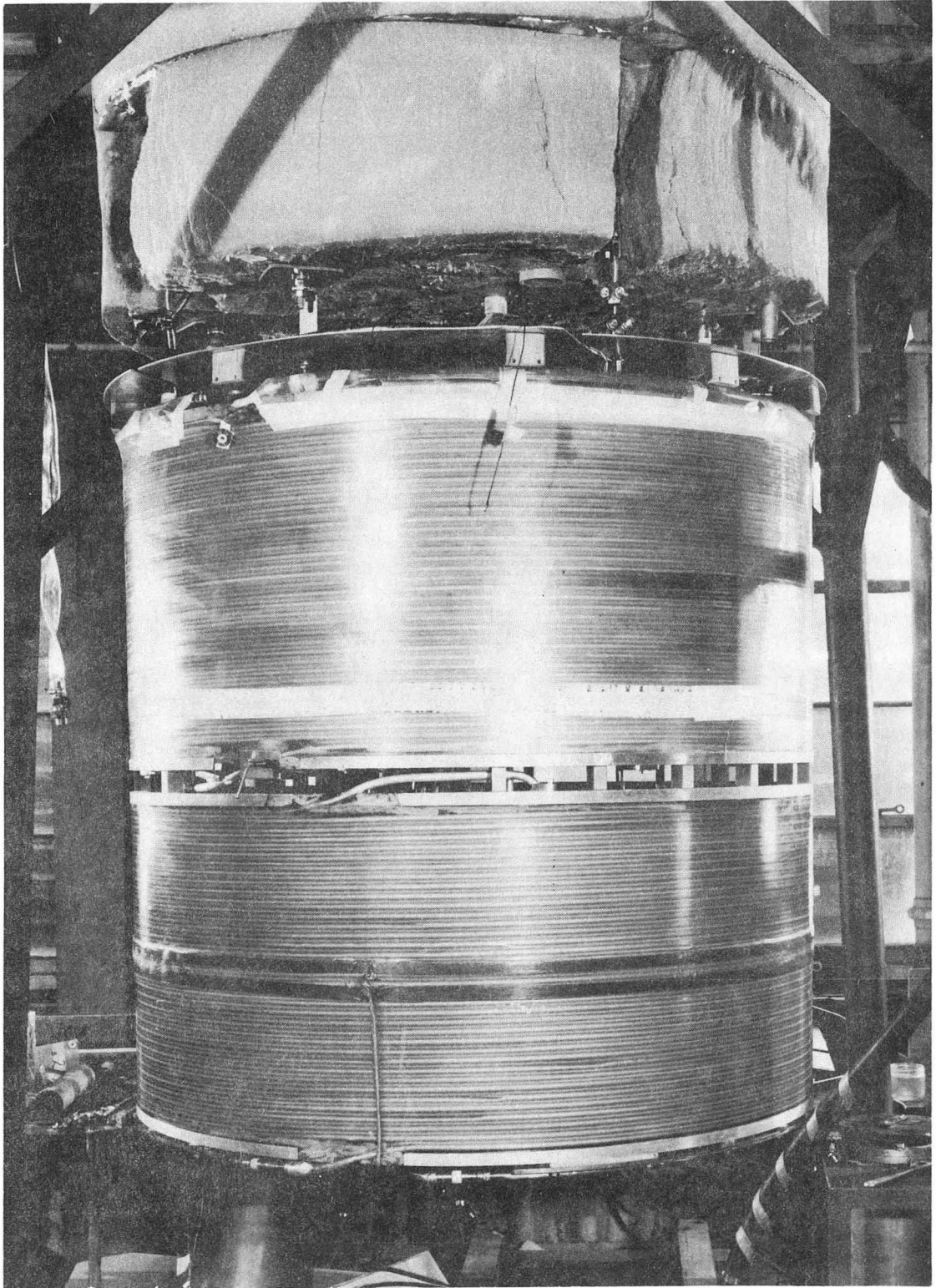

CBB 765-4874

Fig. 5

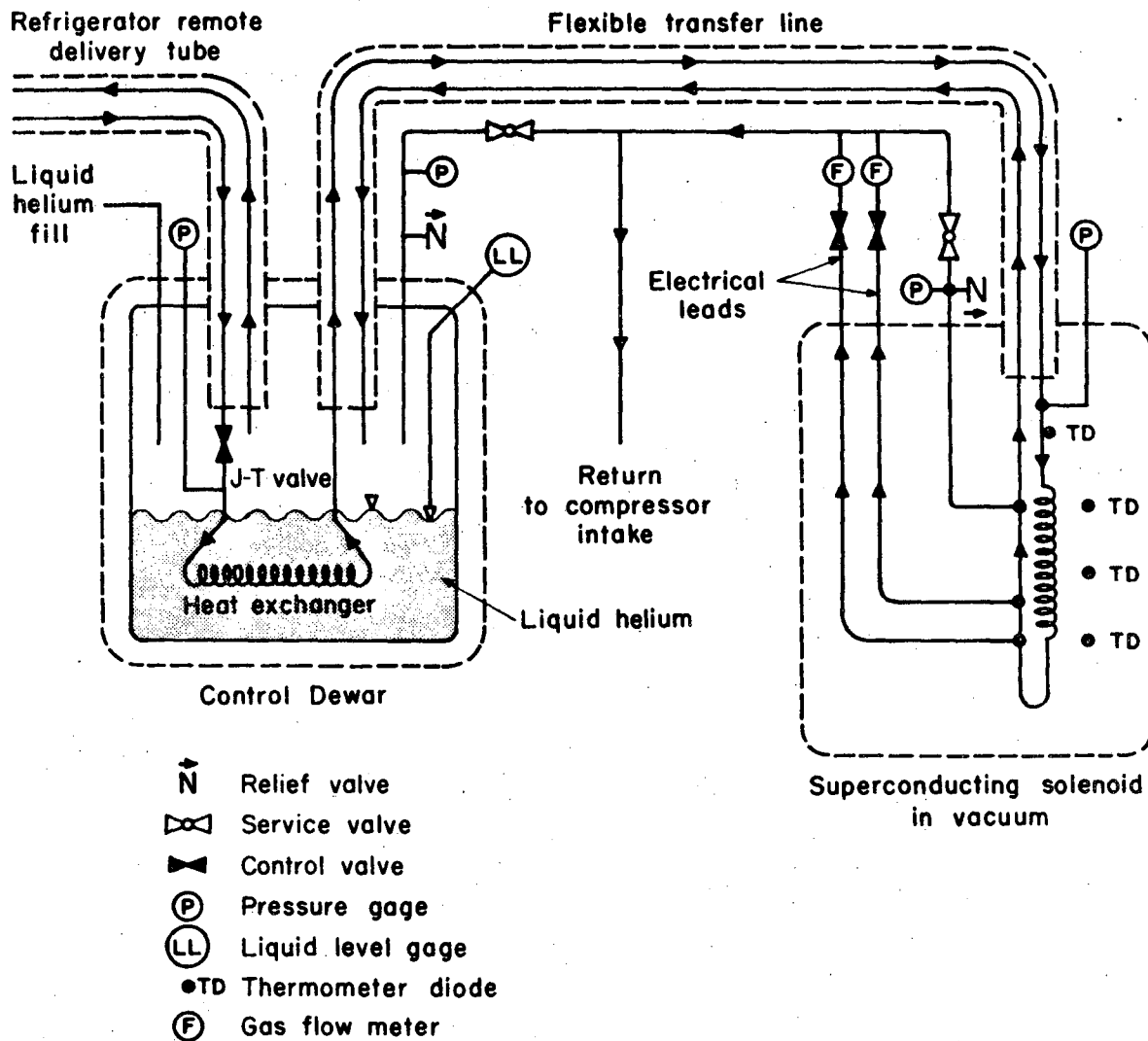

XBL 764-1226

Fig. 6

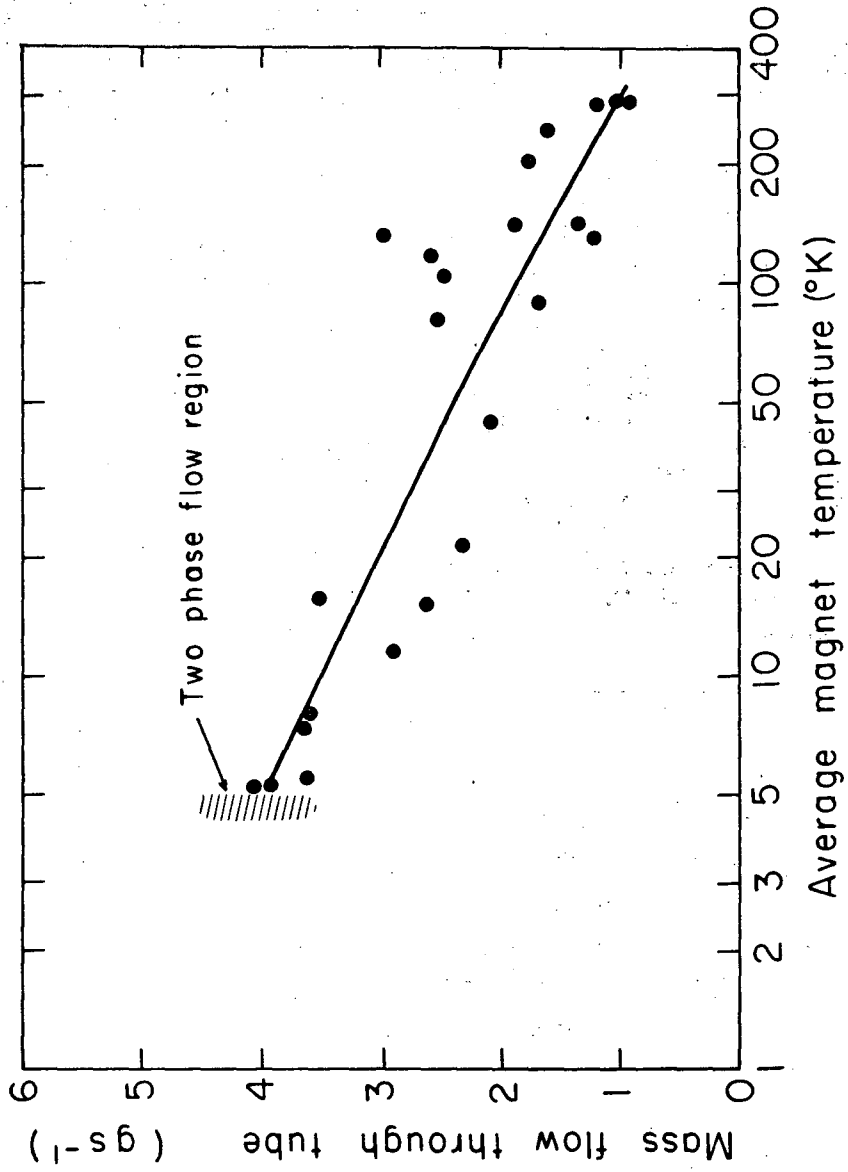

XBL 769-4079

Fig. 7

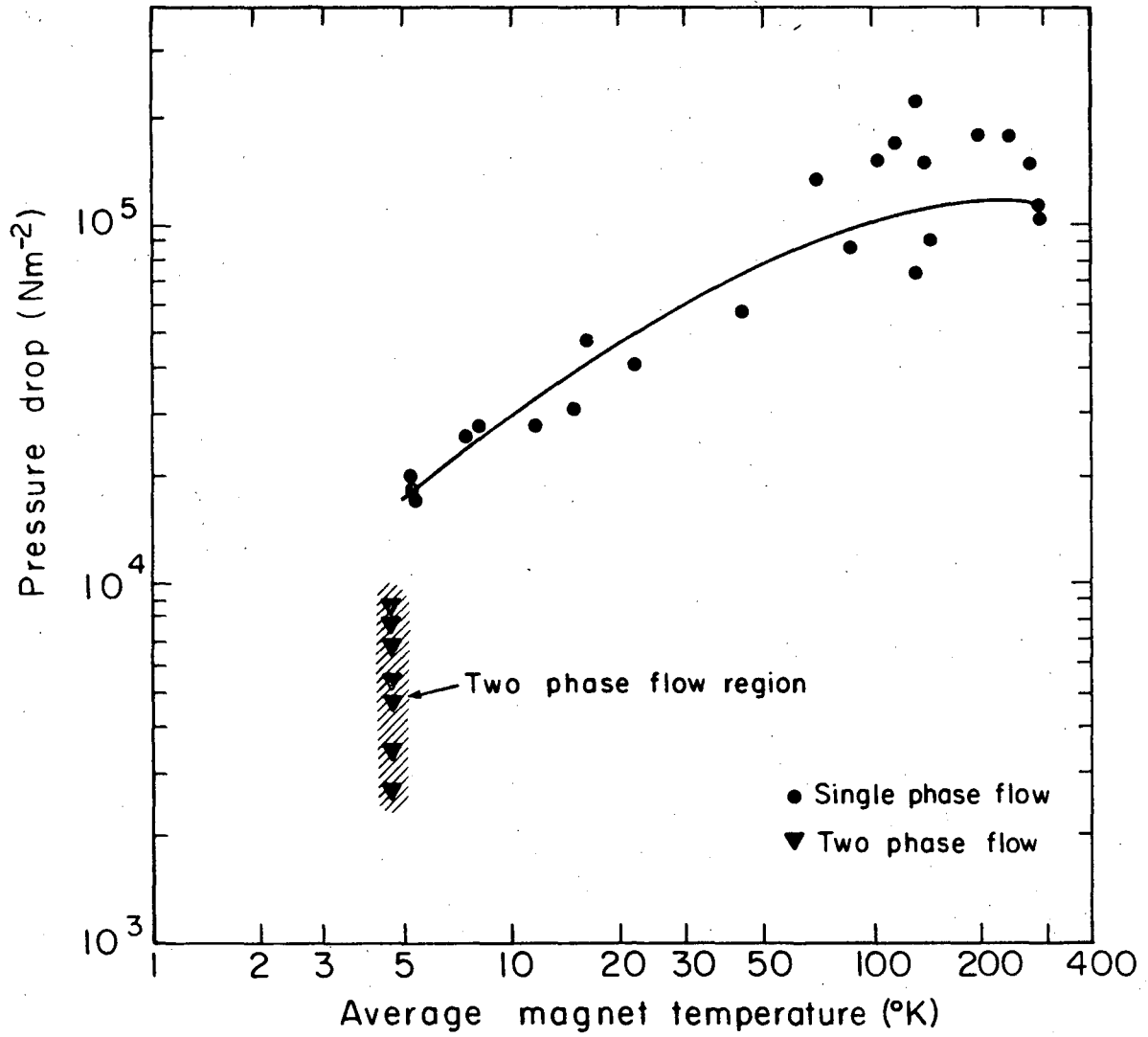
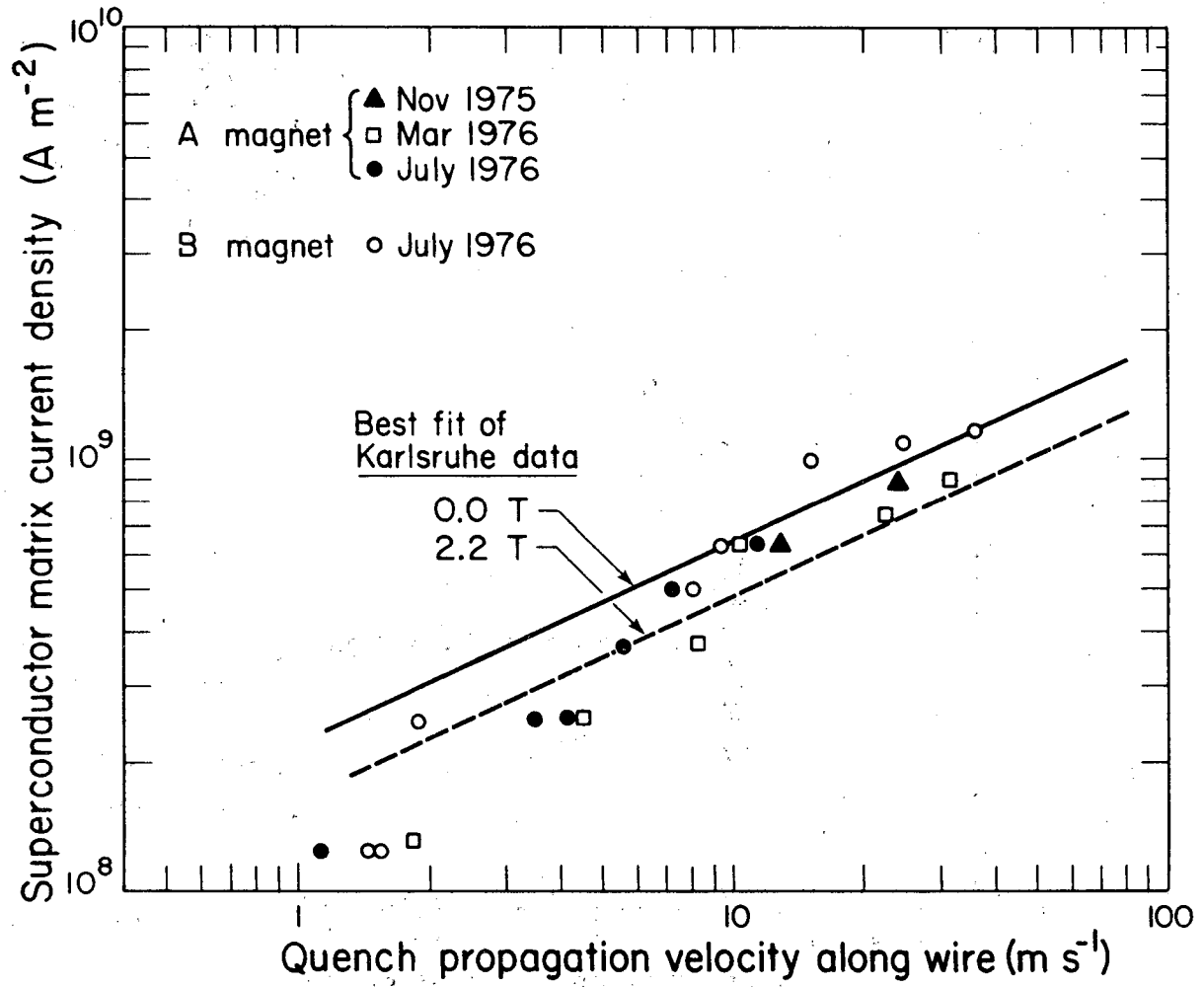

Fig. 8



XBL 769 - 4078

Fig. 9

AA01, TEST 6, LOG 2, RUN 47.

 $I_0 = 700$, $U_Q = 18$ 

Fig. 10



XBL 769-4081

Fig. 11

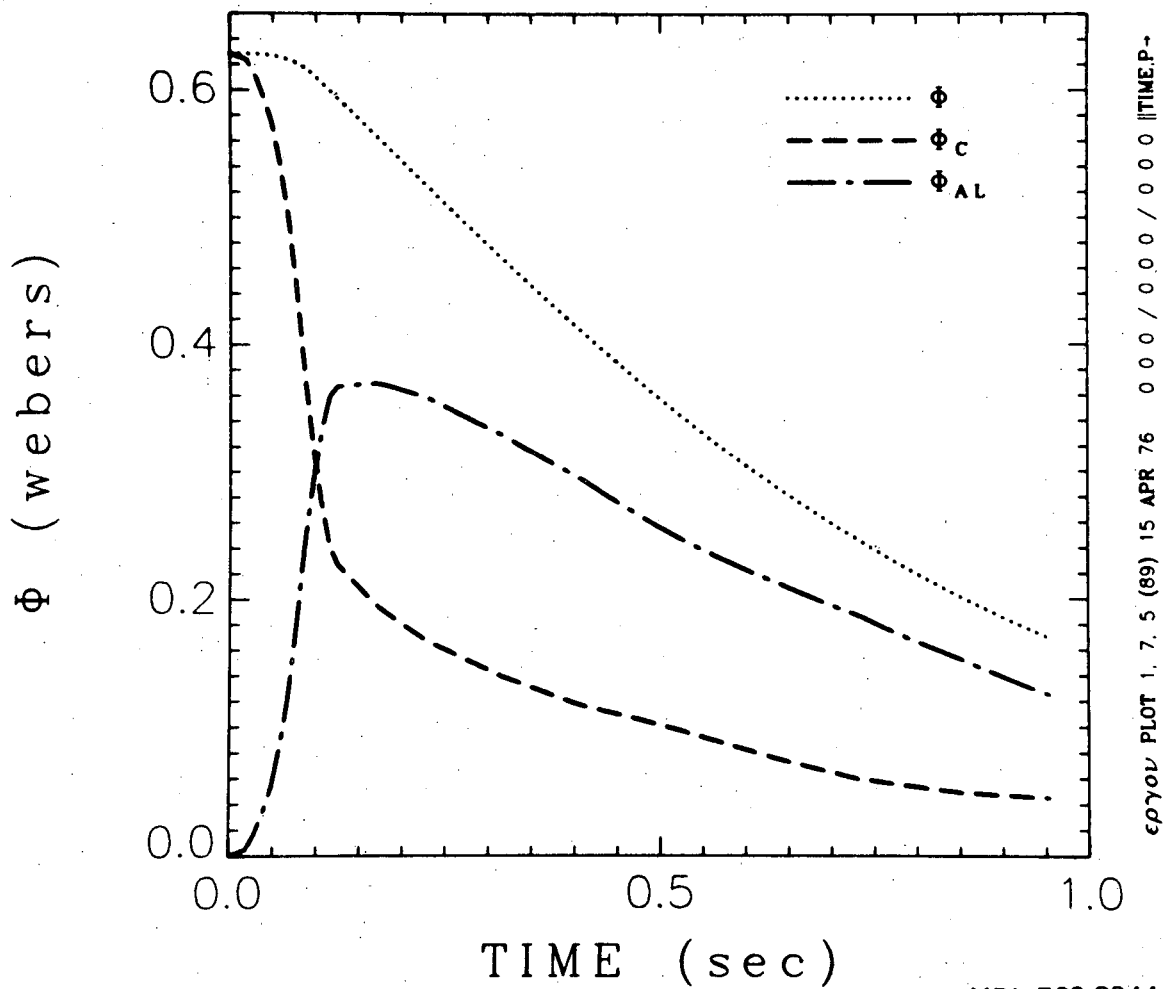
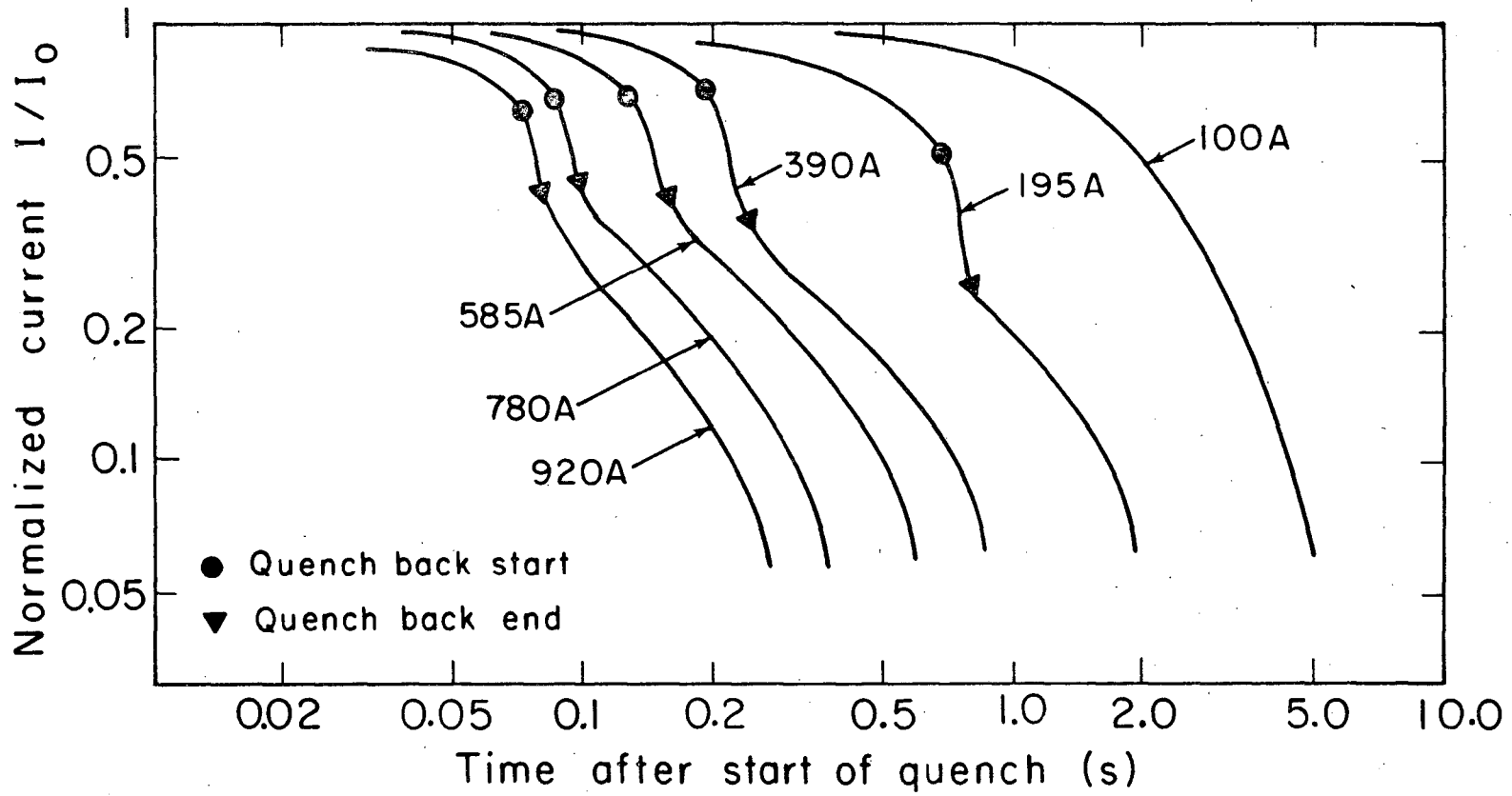
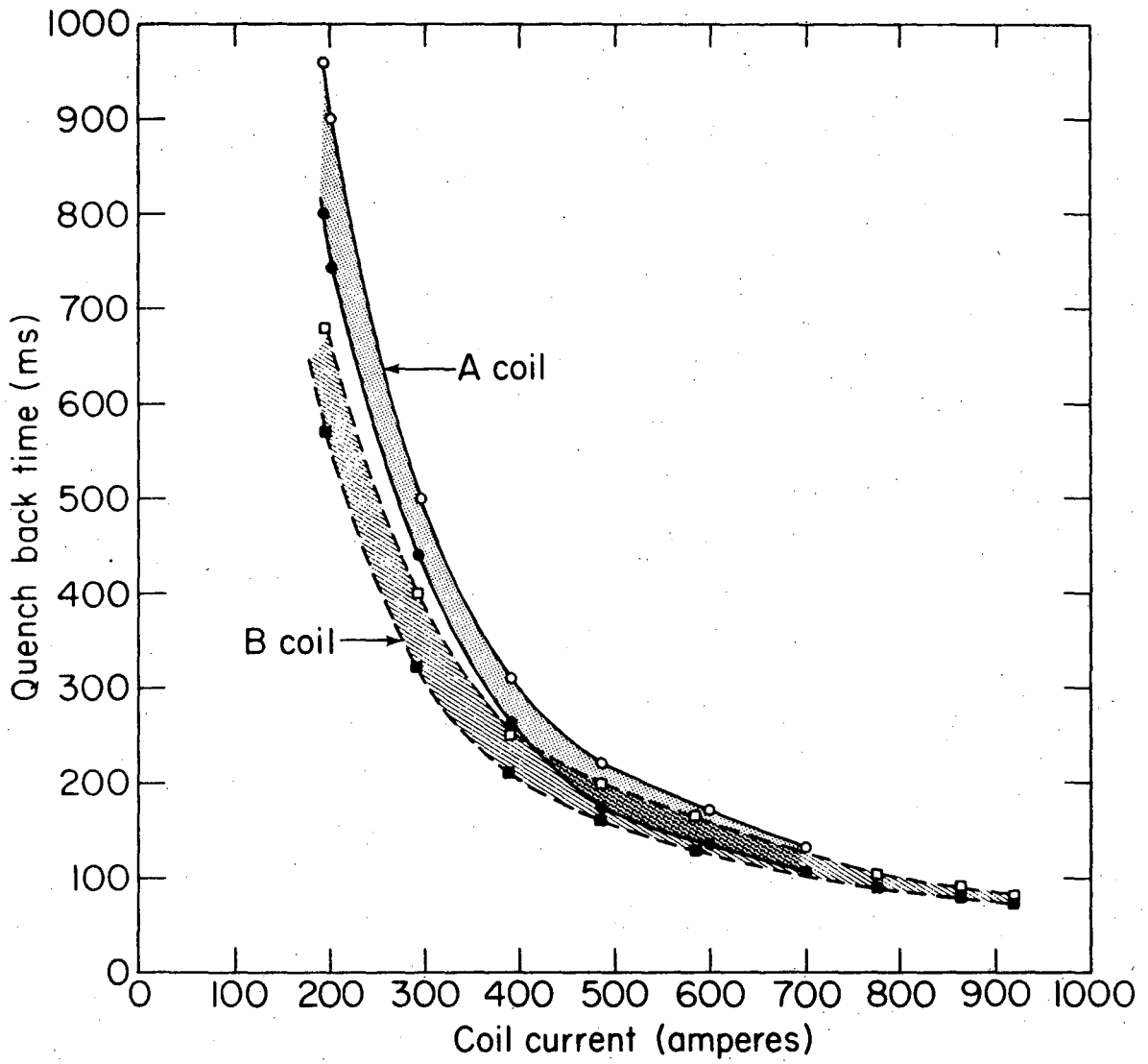

XBL 768-3252

Fig. 12

This report was done with support from the United States Energy Research and Development Administration. Any conclusions or opinions expressed in this report represent solely those of the author(s) and not necessarily those of The Regents of the University of California, the Lawrence Berkeley Laboratory or the United States Energy Research and Development Administration.

TECHNICAL INFORMATION DIVISION
LAWRENCE BERKELEY LABORATORY
UNIVERSITY OF CALIFORNIA
BERKELEY, CALIFORNIA 94720