

# Lawrence Berkeley National Laboratory

## Recent Work

### Title

THE CENTRAL RECEIVER POWER PLANT: AN ENVIRONMENTAL, ECOLOGICAL, AND SOCIOECONOMIC ANALYSIS

### Permalink

<https://escholarship.org/uc/item/2h15b4zw>

### Authors

Davidson, Mark  
Grether, Donald

### Publication Date

1977-06-01

296  
9-12-77

14. 1406

LBL-6329  
UC-62  
TID-4500-R65

MASTER

Energy and Environment Division

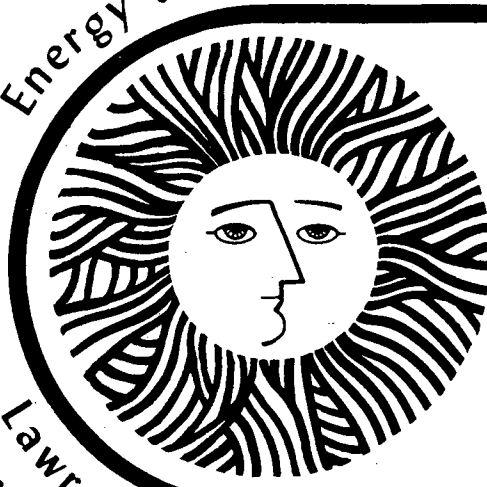

The Central Receiver Power Plant:  
An Environmental, Ecological,  
And Socioeconomic Analysis

*Mark Davidson and Donald Grether*

June 1977

Lawrence Berkeley Laboratory University of California/Berkeley  
Prepared for the U.S. Energy Research and Development Administration under Contract No. W-7405-ENG-48

DISTRIBUTION OF THIS DOCUMENT IS UNLIMITED

LBL-6329

## **DISCLAIMER**

**This report was prepared as an account of work sponsored by an agency of the United States Government. Neither the United States Government nor any agency Thereof, nor any of their employees, makes any warranty, express or implied, or assumes any legal liability or responsibility for the accuracy, completeness, or usefulness of any information, apparatus, product, or process disclosed, or represents that its use would not infringe privately owned rights. Reference herein to any specific commercial product, process, or service by trade name, trademark, manufacturer, or otherwise does not necessarily constitute or imply its endorsement, recommendation, or favoring by the United States Government or any agency thereof. The views and opinions of authors expressed herein do not necessarily state or reflect those of the United States Government or any agency thereof.**

## **DISCLAIMER**

**Portions of this document may be illegible in electronic image products. Images are produced from the best available original document.**



The Central Receiver Power Plant:  
An Environmental, Ecological, and Socioeconomic Analysis

Mark Davidson and Donald Grether

**NOTICE**

This report was prepared as an account of work sponsored by the United States Government. Neither the United States nor the United States Energy Research and Development Administration, nor any of their employees, nor any of their contractors, subcontractors, or their employees, makes any warranty, express or implied, or assumes any legal liability or responsibility for the accuracy, completeness or usefulness of any information, apparatus, product or process disclosed, or represents that its use would not infringe privately owned rights.

DISTRIBUTION OF THIS DOCUMENT IS UNLIMITED

*leg*

## CONTENTS

Acknowledgments . . . . .	iv
List of Tables. . . . .	v
List of Figures . . . . .	vii
I. Introduction. . . . .	1
II. Technical Considerations . . . . .	6
III. Socio-Economic Implications of Central Receiver Technology. . . . .	14
A. Market Penetration. . . . .	14
B. The Model . . . . .	15
C. The Bill of Goods . . . . .	17
D. Industrial Effects. . . . .	21
E. Employment. . . . .	21
F. Effluents . . . . .	33
G. Strains Due to Intensive Construction . . . . .	39
H. Water Requirements. . . . .	52
I. Land Requirements . . . . .	56
IV. Ecological Impacts . . . . .	57
V. Climatological Considerations . . . . .	71
A. Overview. . . . .	71
B. Desert Types. . . . .	75
C. Effects of Surface Albedo Modification. . . . .	76
D. Effects of Aerosols . . . . .	78
E. Effects on Evaporation Rates. . . . .	79
F. The Heliostat Canopy. . . . .	81
G. Effects on Turbulent Transfer Rates . . . . .	81
H. Effects on the Wind Profile . . . . .	83
I. A Model of Convection About a Central Receiver Plant. . . . .	83
J. A Global Scenario with some Model Applications. . . . .	89
1. The Scenario. . . . .	89
2. Global Radiation Temperature Change . . . . .	96
3. Results of ZAM2 . . . . .	100
VI. Conclusion . . . . .	104
Appendix 1 - Heliostat Designs. . . . .	108
Appendix 2 - Rest of Plant. . . . .	114
Glossary. . . . .	133
References for the Central Receiver Study . . . . .	137



Acknowledgments

The authors would like to thank the following people for their help and encouragement in preparing this manuscript. Professor J. Stebbins and John Harte for their insight on ecological problems. Barry Wolfson for helping to build the effluents model used in the text. Mark Horovitz for his assistance in the economic modeling. Jerry Weingart for many interesting discussions regarding solar energy. Steven Schneider, Will Kellog, Gerald Potter, Chandrakant Bhumralker, Jill Williams, and Klaus Fraedrichs for their insight into climatology and the possible effect of central receivers. Mike Wahlig for a number of interesting and informative discussions. The ERDA technical advisors at Sandia Laboratory for helping in collecting necessary background data. The ERDA/SAN office for assisting us in obtaining reports on central receivers. Dean Merrill for assistance in using the employment matrix discussed in the text. Peter House for helpful hints on how to access information regarding effluents. The CDC corporation for providing us with tapes containing effluents data. Finally we would like to thank the various staff members of the Energy and Environment Division and in particular our typist Jan Bacon, for their support and assistance during the course of this work.

LIST OF TABLES

<u>Table Number</u>	<u>Title</u>	<u>Page</u>
I.	Demands on Industry Resulting from Construction of a 100 MW <sub>e</sub> Central Receiver Power Plant.	19
II.	Employment Resulting from the Construction of a 100 MW <sub>e</sub> Central Receiver Power Plant (in thousands of man years)	22
III.	Effluents Associated with Manufacture of Component Parts for 100 MW <sub>e</sub> Central Receiver Power Plant (assuming 1990 EPA pollution standards)	34
IV.	Effluent Release from 1972 Average Generator in Producing Energy Equivalent of 100 MW <sub>e</sub> Central Receiver Plant	35
V.	Comparison Between Central Receiver and Various Fossil Fuels for Major Air Emmissions	38
VI.	Industrial Demand Resulting from Construction of 10 GW <sub>e</sub> of Central Receiver Power Plants	40
VII.	Employment Induced by Building 10 GW <sub>e</sub> Capacity of Central Receiver Power Plants (in thousands of man years)	42
VIII.	Effluent Release Due to the Construction of 10 GW <sub>e</sub> Capacity of Central Receiver Power Plants Assuming 1990 EPA Emission Standards	50
IX.	Estimated Water Use and Projected Requirements by Regions, United States <sup>1</sup>	54
X.	Estimates of Surplus Fresh Water Based on Annual Flows Available 90 and 95% of Years and Total Freshwater Consumptive Use, Excluding Steam-Electric Power, for Years 1980 and 2000	55

<u>Table Number</u>	<u>Title</u>	<u>Page</u>
XI.	Threatened Taxon Which Might be Affected by the Central Receiver Power Plant	69
XII.	Mirror and Land Areas for Scenario by Rough Location	92
XIII.	Latitude-Longitude Limits for Solar Land in Global Scenario	94
XIV.	Solar Land Areas by Zone for the Global Scenario as Used by ZAM2	95
A2-1	Preliminary Characteristics of 10 MWe Solar Central Receiver Power Plant	123

LIST OF FIGURES

<u>Number</u>	<u>Title</u>	<u>Page</u>
II-1	Schematic for a Typical Rankine Cycle Central Receiver Power Plant	7
III-1	Direct Increase in Jobs Due to the Manufacture of a 100 MW <sub>e</sub> Central Receiver Power Plant	31
III-2	Cumulative Increase in Jobs Due to the Manufacture of a 100 MW <sub>e</sub> Central Receiver Power Plant	32
III-3	Effluent Comparison Between Central Receiver and Average 1972 Generator	36
V-1	Map Showing Distribution of Solar Plants in the Global Scenario	93
V-2	Radiation Temperature Change as a Function of Installed Capacity of Central Receiver Plants for Different Desert Albedos	99
V-3	Temperature Difference by Latitude at Surface Resulting from Global Scenario in ZAM2.	102
V-4	Precipitation Difference by Latitude Resulting from Global Scenario in ZAM2	103
AI-1	Pilot Plant Heliostat Concepts	113
AII-1	Pilot Plant Receiver Concepts	124
AII-2	Comparison of the Mirror Field Layouts	125

<u>Number</u>	<u>Title</u>	<u>Page</u>
AII-3	Martin Marietta 10 MW <sub>e</sub> Pilot Plant Design	126
AII-4	Solar Thermal Test Facility	127
AII-5	Honeywell 10MW <sub>e</sub> Pilot Plant Design	128
AII-6	McDonnell Douglas 10 MW <sub>e</sub> Pilot Plant Design	129
AII-7	Honeywell Preliminary Central Receiver Solar Thermal Power System	130
AII-8	McDonnell Douglas Preliminary Central Receiver Solar Thermal Power System	131
AII-9	Martin Marietta Preliminary Central Receiver Solar Thermal Power System.	132



"The desert says nothing. Completely passive, acted upon but never acting, the desert lies there like the bare skeleton of Being, spare, sparse, austere, utterly worthless, inviting not love but contemplation. In its simplicity and order it suggests the classical, except that the desert is a realm beyond the human and in the classicist view only the human is regarded as significant or even recognized as real."

Edward Abbey from Desert Solitaire.

"Inasmuch as one hundred years should be ample time for the development of all the necessary solar energy technology and hardware, nuclear energy--the technology optimists magical and dangerous solution--may never be needed. All things considered, solar energy is more satisfactory than nuclear energy. It is safer and cleaner, and might even be cheaper (when the waste--accumulation, social and political hazards, and environmental effects of nuclear energy are calculated), and its paraphernalia can be erected with impunity in even the most irresponsible domain."

From the Second Report to the Club of Rome  
(Mesarovic, 1974)

## I. Introduction

The central receiver power plant (hereafter referred to as CR) is one of the possible means of using solar energy to generate electricity. As with other solar technologies, it will have environmental effects which ought to be examined before implementation. Built in large numbers, it would affect the U. S. economy, employment, industrial pollution rates, the ecological balance, and perhaps the climate of arid and semi-arid areas. As illustrated by the two quotes on the preceding page, implementation of this desert technology will likely incur conflict between those looking to solar energy as a panacea for man's mistreatment of his planet, and those who view the desert as a beautiful and revered wilderness area. Some of the issues likely to be raised in such a conflict will be addressed in this paper with the intent of providing information relevant to assessing the central receiver power plant as an option in meeting future energy needs.

The idea of using solar energy to supply some of man's energy needs is an old one. A history of uses of this technology has been given by Meinel and Meinel (1976). Early uses include ignition devices, weapons, and sounding statues which made noises at sunrise. These devices have been found in ancient Mesopotamia, Egypt, and Greece. Archimedes is said to have destroyed the Roman fleet of Marcellus in 212 B. C. at Syracuse by burning the ships with solar rays focused by shields held by soldiers. These colorful beginnings were followed by more practical work by experimenters in the Renaissance and up to modern times.

Solar energy can be used either locally at the point of energy demand or at large central stations. CR's are a large scale central station application. Sunlight can be used directly through technological conversion (solar thermal, photovoltaics) or natural conversion (wind, ocean thermal). The CR is in the former category. There are many devices that could be used for solar thermal conversion: solar ponds, flat plate collectors, parabolic troughs, parabaloidal

dishes, and central receivers. Several studies have identified CR's as the most promising of these means of generating electricity primarily because of the higher conversion efficiency and reduced high temperature plumbing of the CR relative to the other choices.

Commercial CR's (should they actually be built) are likely to be different from current designs particularly in the conversion process. However, we anticipate that many of the important factors from an environmental point of view will be very similar: land area covered, materials used, etc. Current designs provide a basis for estimating the impact of commercial plants.

The CR uses conventional technology to generate electricity. It can also produce synthetic fuels using hydrolysis or some as yet unknown process. A field of heliostats (mirrors capable of rotating about two axes) focuses the direct radiation of the sun onto a localized collector. The energy of the radiation is typically transferred to a working fluid and used to drive a turbine to produce electricity. CR's are best situated in arid or semi-arid regions because they can convert only direct solar radiation which is maximum in desert regions, and because land is relatively inexpensive there.

CR plants are expected to become marketable first as intermediate load machines. Eventually they could be used to produce synthetic fuels with greater market penetration possibilities. The economic viability of these plants are a subject of current debate. An Aerospace study (1974) concluded that these plants might be competitive with fossil fuel intermediate load plants by the 1990's. Both ERDA and EPRI are funding CR programs at present. These projects are not without critics. Bethe (1976) argues that CR plants will be at least a factor of five more expensive than fission plants for base load power. Although he does not specifically address the issue of intermediate load power plants, if his cost estimates are correct, then it is difficult to imagine the CR's could compete in serving intermediate loads with nuclear plants with storage facilities.

Pollard (1976) has come to much the same conclusion. He argues that CR's are simply too expensive to be considered as viable alternatives to nuclear energy or coal for bulk power generation. The main reason for these differences in opinion regarding the future costs of CR's is that it is uncertain how much cost reduction can be achieved with mass production techniques of CR components. The true value of the CR as an energy option remains in doubt.

The renewed interest in solar energy following the 1973 oil embargo provided the impetus needed to begin seriously examining the CR power plant. At present, a number of studies are underway to analyze these plants and build prototype models in this country and elsewhere. In 1974 three systems studies were completed by the Aerospace Corp., Honeywell Corp., and Colorado State University which compared the cost effectiveness of various solar thermal electric conversion devices. The results of these suggested that CR's were the most cost-effective way of generating electricity from solar thermal energy. Following these reports, ERDA in 1975 began a program to design and build a prototype central receiver plant. Three companies were contracted to make preliminary designs of the entire system: Honeywell, MacDonnell-Douglas, and Martin-Marietta. In addition, Boeing was contracted to pursue a novel heliostat design making use of a protective plastic bubble surrounding each heliostat. ERDA plans at least three major facilities. A 5 MW<sub>t</sub> test facility is being built in Albuquerque, New Mexico which is scheduled for completion late in 1977. A 10 MW<sub>e</sub> pilot plant is to be built near Barstow, Ca. Ultimately a 100 MW<sub>e</sub> demonstration plant is planned which is to pave the way to commercial implementation. These ERDA designs use Rankine (steam) cycle systems for the generation phase. EPRI is pursuing a complementary program to ERDA. Two designs for Brayton cycle CR's are being funded, along with assessments of the value of this technology to electric utilities. The future funding of the CR will depend on the results of these ERDA and EPRI programs and on policy decisions regarding the viability of this technology.

In appendices I and II a number of figures are presented which illustrate some of these designs, and artists conceptions of proposed facilities.

Once constructed and in operation, CR power plants will be relatively non-polluting compared to conventional technologies (except nuclear plants). However, large amounts of land, materials, and capital will be required for their construction. The impact of providing these are estimated in this paper.

Most heliostat designs are quite massive as the mirrors must survive terrestrial weather. Towers and storage devices are also massive. In producing these materials, and in building the CR plant, significant amounts of air and water pollutants will be released into the environment. These amounts are estimated in the text and the air releases are compared to those from equivalent fossil fuel plants. The results suggest that overall the CR is more benign than most fossil fuel plants for major air pollutants, a possible exception being natural gas.

Constructing a CR is a labor intensive enterprise (compared to say generating electricity from coal). Approximately 10,000 man years of labor would be required to build one. The distribution of these jobs by occupation are listed in the text. Labor would also be required to maintain these plants, but this is not estimated. Utilizing CRs will make the utility industry more labor intensive than at present, although this is largely because the CR is more expensive than alternatives. The effects of mass production techniques are not estimated.

The impact of CR's on the local desert environment will be substantial and will be judged detrimental by many people. The natural ecosystem will be altered over the large land areas that the CR would occupy. Problems of erosion, dust, increased water runoff, and destruction of wildlife will occur. Demographic shifts to the southwest would accentuate these problems. Water would be required for cooling of Rankine cycle plants and to support this increased population. This would strain the already overtaxed southwestern water supply. Demographic shifts could lead to an even greater increase in demand for water than cooling requirements.

Climate could be affected by the construction and operation of CR plants in arid regions. The main effect identified so far is the potential for increasing precipitation by modifying the desert surface albedo. Climatic effects could be local, regional (also called mesoscale), or global depending on the level of construction of the CR's. Although mankind has done much to modify the surface of the earth, he has not as yet modified the deserts of the world to the extent that CRs could eventually. For this reason, the climatic effects of CRs are of particular importance. Another factor is that the boundaries of many deserts support human populations on the bare subsistence level, and any increase or decrease in the size of these deserts can have dramatic effects on these settlements. The disastrous Sahelian drought in Africa and the encroachment of the Rajasthan desert in India are vivid illustrations of this point.

In section II we shall present a brief review of technical details of the central receiver design. In section III socio-economic questions will be considered. Section IV deals with the ecological effects in the vicinity of the CR plant site. Section V deals with climate, and section VI presents some speculations and conclusions.

## II. Technical Considerations

In Figure II-1 a simplified diagram of a CR plant shows the major components. Many designs exist for these plants. Common to all of the designs are a heliostat field to focus the direct radiation of the sun onto a receiver situated at the top of a tower. The energy of the radiation can be converted into enthalpy in a working fluid in the receiver and used to produce electricity or the radiation might be used in a direct process to produce synthetic fuels. The temperature of the radiation which reaches the earth from the sun is about  $5800^{\circ}\text{K}$ . In principle, it is possible to focus this light on a material and achieve up to this temperature. In practice, optical system limitations limit considerably the temperature attainable with mirror focusing. A solar furnace in France at Orsay has achieved temperatures up to about  $4000^{\circ}\text{K}$ . Because of material problems, these high temperatures cannot be used in known thermodynamic cycles at present. These limitations determine the currently usable temperatures of about  $1200^{\circ}\text{C}$  for Brayton engines, and about  $550^{\circ}\text{C}$  for Rankine cycles.

For many aspects of the CR, several design choices are possible. The two major power generation schemes which have been given serious attention so far are the Rankine cycle (funded by ERDA) and the Brayton cycle (funded principally the EPRI, but also by ERDA). Open (air) and closed (helium) Brayton cycles are being considered by Black and Veatch Corp. and Boeing Corp., respectively. The Rankine cycle presents fewer engineering difficulties than the Brayton because of the lower temperatures of the working fluid. Steam temperatures of  $550^{\circ}\text{C}$  are typical for a high performance steam turbine. Brayton inlet temperatures must be much higher (approximately  $1200^{\circ}\text{C}$ ) to achieve the same efficiency. The heat exchanger in the receiver for the Brayton design is more difficult to build because of material problems at the high temperatures. On the other hand, the Brayton design offers the possibility of bottoming cycles which could boost the efficiency of the system. The open Brayton cycle does

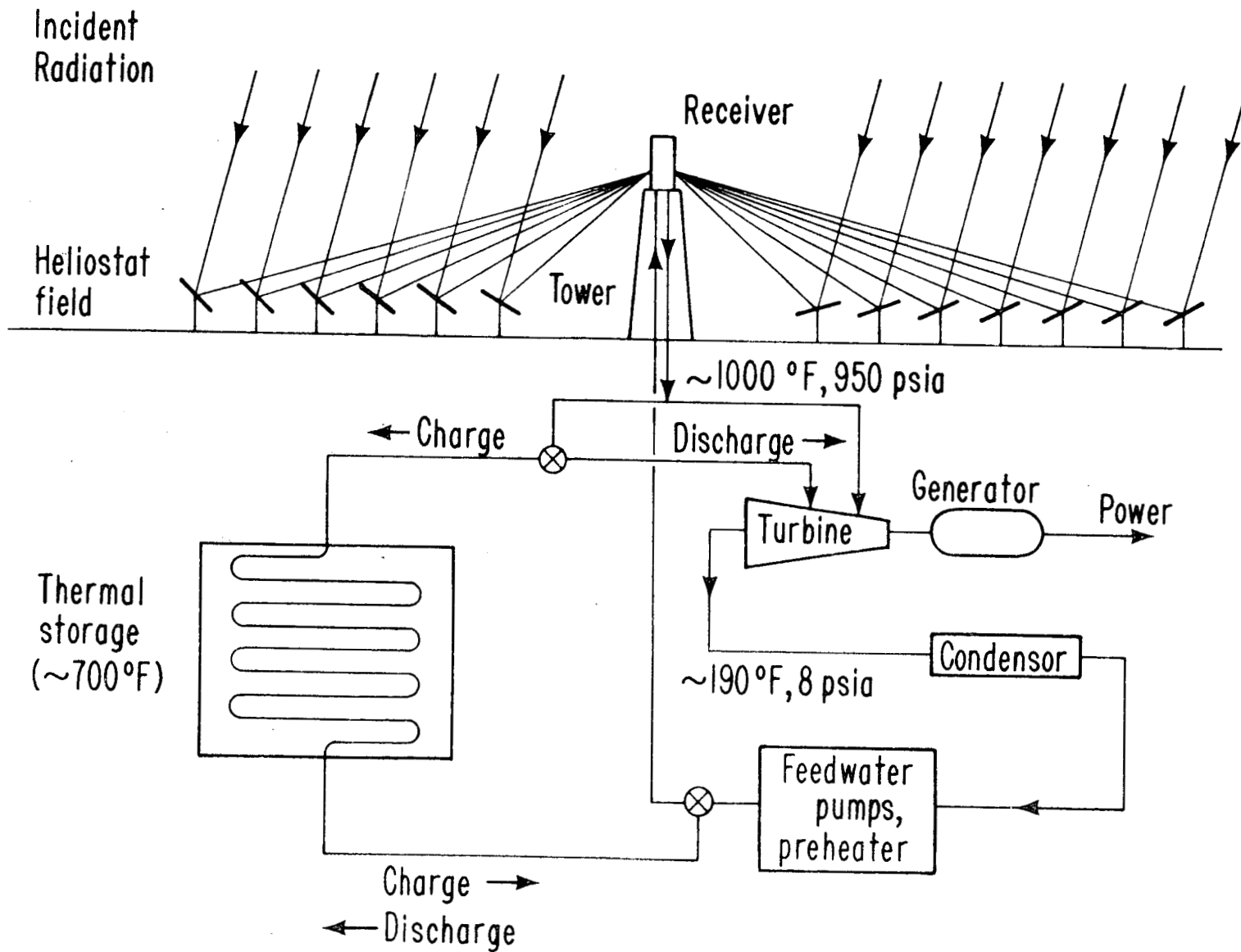

-7-

XBL 775 - 1005

Fig. II-1 Schematic for a Typical Rankine Cycle Central Receiver Power Plant.



not require cooling and therefore has less water requirements unless a Rankine bottoming cycle is added.

Several choices for field geometry exist (see Figure AII-2). Strictly speaking, the central receiver concept refers to a tower located at the center of a circular field. For some designs (and in northern latitudes) it is favorable to have the tower located south of the field center. Other designs have the heliostat field entirely to the north of the receiver. In some designs, a single tower would be used to generate perhaps 100 MW<sub>e</sub>. Another possibility is to have a number of smaller towers, each with their respective fields. Such a modular design scheme has been proposed, for example, by Martin-Marietta (see appendices). The field surface may be flat, terraced to the north, or even bowl shaped. A typical tower height for a 100 MW<sub>e</sub> plant with a single tower is about 300m. Tower height varies very roughly as the square root of the power output of the field feeding the tower.

Since the direct radiation from the sun is intermittent and absent at night, some method of backing up the solar resource is required if the plant is to produce electricity. The backup can be accomplished in essentially three ways. The first is to store energy for later use. The second is to burn a fossil fuel at the solar plant (hybrid system). The third is to have sufficient reserve in the rest of the utility grid to back up the solar plants. The ERDA designs all use storage whereas EPRI is considering hybrid systems.

Different storage systems are also possible. First, energy can be stored in the form of either sensible or latent heat. Latent heat storage can be achieved with eutectic salts for the temperatures desired in a Rankine cycle. Sensible heat storage can use oil or rocks or a combination of both. Thermal storage is not practical for Brayton designs. Other possibilities include batteries, flywheels, compressed air, pumped hydro, and super conducting magnets. The storage schemes for the ERDA designs are listed in

Appendix II. Typical mirror areas for a single heliostat vary from about  $30\text{m}^2$  to about  $40\text{m}^2$ . Each heliostat is rotatable about two axes in order to follow the sun. Since they must withstand extreme variations in the elements these devices must be massive, and this adds significantly to the cost. The Boeing design is the lightest heliostat being funded, but the foundation is still about as massive as the other designs (see Fig. AI-1).

Several types of receiver are being considered (see Fig. AII-1). There is some relationship between receiver and heliostat design. Martin-Marietta and Honeywell have proposed cavity receivers. The absorbing properties of cavities have long been recognized, These receivers require the heliostat mirrors to be focusing to match the cavity aperture. McDonnell-Douglas has designed a cylindrical receiver with absorbing panels on the exterior. Focusing is not so critical for this design and the mirrors could be flat. The material problems for the receiver for a Brayton cycle system are severe. Both of EPRI's designs (open and closed cycle Braytons) are cavities. Direct radiation fluxes on the inside walls of the cavities will reach  $200\text{ kW/m}^2$  and higher. Temperatures will exceed  $1100^\circ\text{C}$  on the walls of the cavity. At present, considerable effort is being devoted to finding suitable materials for the heat exchanger tubes and cavity walls. Silicon carbide tubes with Inkonel joints are the prime candidate.

Tower construction can also vary. Slip form concrete towers and guyed wire towers are often considered. For the Brayton designs, it is considered desirable to carry out the generation at the top of the tower to reduce pressure and temperature losses in transporting the very hot working fluid. This adds to the structural requirements of the tower and therefore its cost. On the other hand, since no storage is provided, the tower and field size are smaller than the ERDA funded designs with the same rated capacity, the extra

power being generated by the hybrid unit.

Land area requirements for CR plants are considerable. Approximately  $1 \text{ km}^2$  of mirror area would be required to supply  $100 \text{ MW}_e$  of intermediate load power<sup>a</sup> using one of the ERDA designs. The ground cover ratio is the ratio of the mirror area to the total area of the CR power plant. This number could vary from as low as .25 to as high as .5. When ground cover is high, shading of one heliostat by another can occur. On the other hand, when ground cover is low, mirror areas are less effectively utilized because of the obliqueness of the heliostats relative to the sun. Land must also be devoted to transmission equipment. Further, one should attribute some land to the formation of the materials which are used to build the plant. A base load power plant would require from 1.5 to 2 times as much mirror area as an intermediate load plant.

CR plants are material intensive structures. Based on estimates of materials by the ERDA funded contractors, the following approximate amounts of steel and concrete would be required to build the heliostat field for a  $100 \text{ MW}_e$  intermediate plant

Steel -	$3.7 \times 10^4$ tons
Concrete -	$2.15 \times 10^5$ tons.

Additional steel and concrete would be needed for the tower, support structures, and storage facilities. Most of the concrete goes into the massive foundation of the heliostats (typically about 8 tons per heliostat), which must survive quite severe winds. For designs which use glass mirrors, the glass requirements would be about  $2.1 \times 10^3$  tons for a  $100 \text{ MW}_e$  intermediate load plant. Such a plant using the Boeing heliostat would require about 350 tons of Tedlar, about 56 tons of Polyurethane, and about 140 tons of Mylar. The MacDonnell-Douglas design would require about 595 kg. of silver and about 2,290 kg of acrylic. In

---

<sup>a</sup>Peak load power is power required only during hours of peak demand, less than six hours a day, usually in the afternoon. Intermediate load power is required more than six hours, but less than 12 hours a day, and base load power is a continuous, non fluctuating demand.

addition, large amounts of storage materials would be required; these are listed when available in Appendix II. Appendix I contains some more detailed information on material requirements of heliostats.

Costs are of primary interest to the economic viability of CR's. The Aerospace report gives the following numbers for the cost per kW<sub>e</sub> of the various components in 1990 dollars assuming mass production: (100 MW<sub>e</sub> intermediate load plant).

Land	\$ 2
Structures and Facilities	44
Heliostats	300
Central Receiver/Tower/Heat Exch.	95
Storage Tanks	90
Boiler Plant	--
Turbine Plant Equipment	80
Electric Plant Equipment	21
Misc. Plant Equipment	4
Allowance for Cooling Towers	<u>20</u>
Total Direct Cost	656
Contingency Allowance	39
Spare Parts Allowance	3
Indirect Costs	<u>78</u>
Total Capital Investment	776
Escalation to Start of Construction	<u>296</u>
Total at Start of Construction	1072
Interest During Construction	119
Escalation During Construction	<u>169</u>
Total Cost at Yr. of Completion	1360
(1990 dollars/kW <sub>e</sub> )	

These cost estimates assume a heliostat cost of \$30/m<sup>2</sup>, a cost that no one would be willing to produce them for today. These estimates are probably optimistic; more recent estimates of heliostat costs are in the range of \$160/m<sup>2</sup>. The 10 MW<sub>e</sub> pilot plant being built in Barstow is going to cost upwards of 100 million dollars, or more than \$10,000 per kilowatt. Of

course mass production techniques will reduce this cost. A reduction of about a factor of 10 is required to achieve the Aerospace estimates. Whether or not this can be achieved remains to be seen. Note that heliostats account for about half of the total direct costs in the Aerospace estimates.

The following cost estimates were presented at the 1976 ISES conference in Winnipeg (Blake, 1976 and Easton, 1976).

Martin-Marietta Cost Estimates: 1975 dollars/kW<sub>e</sub>, for a 100 MW<sub>e</sub> intermediate load plant:

Heliostat Collectors	759.14
Storage Tanks, Heat Exchangers	15.13
Storage Fluid, HITEC, Thermia	153.5
Main Plant, Site, Services	114.73
Turbine, Generator, Foundation	82.62
Towers, Riser/Downcomer	180.37
Steam Generator, Controls	182.27
Air Cooled Condenser, Circulation System	61.10
Total Installed System	1685.0

McDonnell-Douglas Cost Estimates: 1975 dollars/kW<sub>e</sub>, for a 100 MW<sub>e</sub> intermediate load plant:

Collector Subsystem	678.0
Receiver Subsystem	143.0
Thermal Storage Subsystem	122.0
Master Control Subsystem	5.0
Electric Power Generation System	230.0
Operational/site activation	32.0
Total Solar Plant	1210.0

These estimates correspond to heliostat costs of  $\$76/\text{m}^2$  for the Martin Marietta design and  $\$68/\text{m}^2$  for the McDonnell-Douglas design. It should be emphasized that these estimates are based on assumptions of cost reductions through the use of mass production techniques. A rather crude analogy can be made to the automobile, which is mass-produced using many of the same materials (steel, glass, electrical equipment) as the heliostats. Taking the weight of steel to be about  $75 \text{ lbs}/\text{m}^2$  of heliostat, and the cost of steel components to be about  $\$1$  per pound (the cost of a very austere car in 1975 dollars), the heliostat would cost about  $\$75/\text{m}^2$ . The cost of the concrete foundation might add another  $\$25/\text{m}^2$  for a total of  $\$100/\text{m}^2$ . This analogy indicates that the estimated heliostat costs may be realizable, but will involve a considerable cost-reduction effort. As a final point, these estimates are considerably higher than that ( $\$30/\text{m}^2$  in 1990 dollars) used in Aerospace studies.

### III. Socio-Economic Implications of Central Receiver Technology

#### A. Market Penetration

In this section the potential effects of CRs on the U.S. economy, employment, and pollution levels will be examined. The impacts of this technology will be roughly proportional to the level of market penetration which it will achieve in the future. It is beyond the scope of this report to predict or model this penetration. ERDA (1976) in its national energy plan has proposed the construction of 50 - 100 GWe of baseload equivalent solar electric power plants by the year 2000. This corresponds to the construction of from 1200 to 2400 100 MWe intermediate load CR power plants if all the solar electric construction is of the CR type. In other words, from 120 to 240 GWe of intermediate load capacity. Not all of this capacity would be of the CR type, so that perhaps 100 GWe of CR capacity is more in keeping with the plan of ERDA. The total intermediate load demand in the U.S. at present corresponds to a capacity of about 120 GWe. Much of this demand is in the Northeast which is too far to transmit electricity from the Southwest. On the other hand, electricity demand may increase between now and the year 2000. Assuming a 2% growth rate in demand (which lies between high growth and low growth projections), the required intermediate capacity would be about 189 GWe in the year 2000. Thus 100 GWe appears to be a reasonable upper bound for the implementation of CR plants of intermediate type in this century. Utilities will be slow in accepting this technology and its high capital costs. Moreover, the trend is toward

peak power pricing to achieve load leveling, and this could reduce the intermediate load demand.

The actual level of market penetration depends on a number of factors that cannot be determined with any degree of certainty. These include the future cost of a CR power plant; the future price and availability of alternative fuels; and the perceived or actual environmental acceptability of CR plants as compared to conventional technologies. Government intervention or subsidy (on behalf, for example, of the environment or reduced dependence on fossil fuels) is likely to be a significant factor. The general approach in this and following sections will be to implicitly assume that the technology will be implemented and to examine the consequences, often without reference to a particular scenario of market penetration.

#### B. The Model

In order to analyze the effects of building a given number of central receiver power plants, a model has been developed which simulates the industrial sector in the U.S., the ramifications on employment of a given industrial activity, and the level of effluent production associated with such an activity. The model uses a 93 sector input/output (I/O) total requirements matrix for 1972 which is stored on the Lawrence Berkeley Laboratory computer and was obtained from the Bureau of Economic Analysis. One begins with an initial vector corresponding to an increase in demand in each of the 93 industry sectors. Multiplication of this vector by the input/output matrix approximates the effects of higher order



interchanges between industries and produces an estimate of the total increase in demand for the output of each of the industrial sectors. The next step involves a 93x423 matrix which contains data on the number of jobs broken down into 423 occupations that are required for the production of a unit of output in each of the 93 industry sectors. Multiplication of the total output or demand vector by this matrix yields an estimate of the number of jobs in each occupation which would be created by the increase in demand. This employment matrix was developed at Lawrence Berkeley Laboratory (Merrill, 1976) and is stored for general use on the laboratory computer. The final tool used in the analysis was a 93x43 matrix which contains the effluent production of each of the 93 industries (normalized by the output of the industry) for 43 different effluent types, including major air and water pollutants. Since the effluents matrix was formed as part of this project, a brief description of it will be given here.

The prime source for the effluents matrix was data gathered by the SEAS project of the Environmental Protection Agency (House, 1977). These data include gross outputs of various effluents by the SEAS industry classification, for 1972. Also included are a number of options for pollution control corresponding to various future EPA standards. In most cases, the control used corresponded to 1990 EPA standards. The most stringent standards for treatment were applied to obtain a matrix of net effluents produced by industry that is expected to be somewhat representative of the timeframe of implementation of the CR technology. Since the SEAS industry classifications did not correspond to those used in our I/O model, an aggregation was performed. Each of the SEAS industries was mapped into one of the 93 I/O model industries

to yield net effluent production by 43 effluents and 93 industries. The final part of the calculation was to normalize the net effluents for each industry by the dollar output of the industry in 1972. The resulting matrix is an approximation to the effluents which will be produced in 1990 by each of the 93 industries per (1972) dollar of output. Suppose an increase in dollar demand on industry  $i$  is given in 1972 dollars. Then, by multiplying by the proper elements in the effluents matrix, one obtains an estimate of the pollution which this activity would produce in the year 1990. Multiplication of the total demand vector by this effluents matrix yields an estimate of the total effluents released as caused by an increase in direct demand in 1990.

#### C. The Bill of Goods

In order to use the model, an estimate must be made of the demands on each of the 93 industries which would result from building a CR plant. We shall call this estimate (in 1972 dollars) a "bill of goods". The best available data from which such a bill could be constructed was provided by the Honeywell Corp. in their Preliminary Design Baseline Report for the CR project. (This document exists as an internal ERDA document, copies may be examined at the ERDA - SAN office in Oakland, CA, but are not available for distribution.) In this report a cost breakdown was given for the components of the plant, based on wholesale prices at the time the report was written. Most of these figures correspond to 1973 or 1974 dollars. In using these estimates, inflation from 1972 was ignored because it represented a small factor relative to the other uncertainties in this procedure. It should be emphasized that

neither Honeywell nor ERDA will attest to the accuracy of these cost estimates, and they may have been superseded or updated by the time this report is released. It should also be emphasized that the Honeywell design is but one of four under study with ERDA funding. Our use of their cost calculations represents neither an endorsement nor an indictment of the Honeywell design. Rather, we take this design as representative of a CR plant for the purposes of constructing our bill of goods. We would expect future developments of CR designs to modify the details but not the qualitative results of our analysis.

The bill of goods based on the Honeywell estimates may be read in Table I. These correspond to a considerably higher cost per kWe of installed capacity than the Aerospace estimates listed in Section II. Honeywell estimated the cost of buying the components of the CR plant at present wholesale prices, whereas Aerospace assumed considerable cost reductions due to mass production techniques (they assumed for example a cost of \$30/m<sup>2</sup> for heliostats). Since our model is based on the 1972 U.S. economy, it is appropriate to estimate the bill of goods based on the Honeywell data. The results of the model can then be interpreted as the effects that would be felt in our economy if central receivers were built with the present industrial structure. In this process, we may be overestimating the number of man years involved in building such a plant compared to mass production techniques. However, our modeling capabilities do not allow us to predict the effects of mass production.

Table I. Demands on Industry Resulting from Construction of a 100 MW<sub>e</sub> Central Receiver Power Plant.

ALL DOLLAR FIGURES ARE IN MILLIONS

I-O NUMBER	I-O DESCRIPTION	1972 OUTPUT LEVEL	DIRECT INCREASE IN DEMAND (BILL OF GOODS)	DID/1972	CUMULATIVE INCREASE IN DEMAND	CID/1972
1	LIVESTOCK AND LIVESTOCK PRODUCTS.	46283.674814			.60272	.00001
2	OTHER AGRICULTURAL PRODUCTS.	41415.269545			.56892	.00001
3	FORESTRY AND FISHERY PRODUCTS.	4255.561954			.25374	.00006
4	AGRICULTURAL FORESTRY, FISHERY SERVICES.	2136.228270			.03922	.00002
5	IRON AND FERROALLOY ORES MINING	1917.541854			1.86362	.00097
6	NONFERROUS METAL ORES MINING	2943.898028			1.56430	.00051
7	COAL MINING	5571.784337			1.71812	.00031
8	CRUDE PETROLEUM AND NATURAL GAS	19709.608544			1.58128	.00006
9	STONE AND CLAY MINING AND QUARRYING	3151.445184			.66464	.00021
10	CHEMICAL AND FERTILIZER MINERAL MINING	1055.955838			.31816	.00030
11	NEW CONSTRUCTION.	122240.300000	1.000000	.00001	1.00000	.00001
12	MAINTENANCE AND REPAIR CONSTRUCTION.	30390.000000			2.02804	.00007
13	ORDINANCE AND ACCESSORIES.	10434.796087			.24742	.00002
14	FOOD AND KINDRED PRODUCTS	118103.620578			1.38780	.00001
15	TOBACCO MANUFACTURES.	10017.083506			.06426	.00001
16	BROAD AND NARROW FABRICS.	19921.681074			.59375	.00001
17	MISCELLANEOUS TEXTILE GOODS, FLOOR COVER	7434.169833			.38912	.00005
18	APPAREL.	29713.352024			.29704	.00001
19	MISCELLANEOUS FABRICATED TEXTILE PRODUCT	6130.483935			.16756	.00001
20	LUMBER AND WOOD PRODUCTS.	23521.278520			1.81840	.00006
21	WOODEN CONTAINERS.	973.464853			.18732	.00019
22	HOUSEHOLD FURNITURE.	7813.306000			.17174	.00002
23	OTHER FURNITURE AND FIXTURES.	4073.854753			.08965	.00002
24	PAPER AND ALLIED PRODUCTS.	24175.580822			2.59509	.00011
25	PAPERBOARD CONTAINERS.	7987.375704			1.56437	.00020
26	PRINTING AND PUBLISHING.	29028.220050			1.86844	.00006
27	CHEMICALS AND SELECTED PRODUCTS.	29071.367150	4.670540	.00016	9.55925	.00033
28	PLASTICS AND SYNTHETIC MATERIALS.	11385.802410			1.55133	.00014
29	DRUGS, CLEANING, TOILET PREPARATIONS.	16854.969184			35779	.00002
30	PAINTS AND ALLIED PRODUCTS.	3856.892152			.73794	.00019
31	PETROLEUM REFINING, RELATED PRODS	33590.761110			2.24663	.00007
32	PAVING MIXTURES AND BLOCKS	752.500000			.03012	.00004
33	ASPHALT FELTS AND COATINGS	740.277060			.06513	.00009
34	RUBBER AND MISCELLANEOUS PLASTICS PRODUCT	21971.049539	1.009200	.00005	3.68885	.00017
35	LEATHER, TANNING AND INDUSTRIAL.	1263.369616			.05647	.00004
36	FOOTWEAR AND OTHER LEATHER PRODUCTS.	4880.605552			.01852	.00000
37	GLASS AND GLASS PRODUCTS.	6310.353223	4.171360	.00066	5.29434	.00084
38	STONE AND CLAY PRODUCTS.	15467.125763	4.216800	.00027	6.28107	.00041
39	PRIMARY IRON AND STEEL MANUFACTURING.	40932.954566	14.603975	.00036	45.94938	.00112
40	PRIMARY NONFERROUS METAL MANUFACTURING	31440.511146			17.91604	.00057
41	METAL CONTAINERS	5053.611713			.51952	.00010
42	HEATING, PLUMBING AND STRUCTURAL.	17120.056239	31.290900	.00183	33.13598	.00194
43	STAMPING, SCREW MACHINE PRODUCTS.	44229.670213	34.662654	.00292	36.67233	.00415
44	OTHER FABRICATED METAL PRODUCTS	17459.246635	5.872131	.00033	10.52730	.00060
45	ENGINES AND TURBINES.	6479.042708	8.775000	.00135	16.55082	.00163
46	FARM MACHINERY AND EQUIPMENT	6219.033649			.57833	.00009
47	CONSTRUCTION, MINING AND FIELD.	6764.167820			1.11197	.00013
48	MATERIALS HANDLING EQUIPMENT	2295.252981			.21556	.00007
49	METALWORKING MACHINERY AND EQUIPMENT.	8744.297170			1.91965	.00022
50	SPECIAL INDUSTRY MACHINERY.	7327.732198			7.1285	.00009
51	GENERAL INDUSTRIAL MACHINERY.	9721.250514	29.721400	.00106	12.88003	.00014

Table I. (continued)

52MACHINE SHOP PRODUCTS.	4469.174737			1.77765	.00040
53OFFICE, COMPUTING, ACCOUNTING MACHINERY.	9010.307472	1.039569	.00012	1.37057	.00015
54SERVICE INDUSTRY MACHINERY.	9851.059371			1.30754	.00013
55ELECTRIC INDUSTRIAL EQUIPMENT.	12121.872927	13.873254	.00114	18.37139	.00152
56HOUSEHOLD APPLIANCES.	7852.095548			.38989	.00005
57ELECTRIC LIGHTING AND WIRING EQUIPMENT.	6192.935625			.90469	.00015
58RADIO, TELEVISION, COMMUNICATIONS EQUIPM	24055.009838			1.96391	.00008
59ELECTRONIC COMPONENTS.	10079.486356	4.034527	.00040	6.15403	.00061
60MISCELLANEOUS ELECTRICAL MACHINERY.	5223.491144	6.351327	.00122	7.45383	.00143
61MOTOR VEHICLES AND EQUIPMENT.	77561.778889			3.48509	.00004
62AIRCRAFT AND PARTS.	27389.061892			1.72618	.00006
63OTHER TRANSPORTATION EQUIPMENT.	12853.508291			1.04628	.00008
64SCIENTIFIC AND CONTROL INSTRUMENTS.	8300.785452			.50434	.00006
65OPTICAL AND PHOTOGRAPHIC EQUIPMENT.	7317.677116	.269120	.00004	.44201	.00006
66MISCELLANEOUS MANUFACTURING.	13598.788309			.41860	.00003
67RAILROADS AND RELATED SERVICES	15842.333777			2.47372	.00016
68LOCAL, SUBURBAN PASS. TRANSIT	5382.900000			.13555	.00003
69MOTOR FRT TRANS + WAREHOUSING	30207.300000			3.74436	.00012
70WATER TRANSPORTATION	9970.550703			.66869	.00007
71AIR TRANSPORTATION	13437.132213			1.14713	.00009
72PIPELINE TRANSPORTATION	1489.200000			.05985	.00004
73TRANSPORTATION SERVICES	1458.400000			.11602	.00008
74COMMUNICATIONS, EXCEPT RADIO AND TELEVIS	30364.900000			2.30176	.00008
75RADIO AND TELEVISION BROADCASTING.	4411.700000			.44665	.00010
76ELECTRIC UTILITIES	32542.991730			3.30931	.00010
77GAS UTILITIES	21736.200581			2.80834	.00013
78WATER AND SANITARY SERVICES	6463.900000			.35949	.00006
79WHOLESALE AND RETAIL TRADE.	253562.000000			12.70628	.00005
80FINANCE AND INSURANCE.	81643.700581			3.32879	.00004
81REAL ESTATE AND RENTAL.	147665.600000			4.43111	.00003
82HOTELS, PERSONAL AND REPAIR SERVICES.	24314.800000			.07549	.00000
83BUSINESS SERVICES.	88581.000000			9.35956	.00011
84AUTOMOBILE REPAIRS AND SERVICES.	22569.600000			.97387	.00004
85AMUSEMENTS.	14789.100000			.31843	.00002
86MEDICAL, EDUCATIONAL, SERVICE, AND NONPR	98278.000000			.42052	.00000
87FEDERAL GOVERNMENT ENTERPRISES.	12087.000000			.66691	.00006
88STATE AND LOCAL GOVERNMENT ENTERPRISES.	11036.900000			.52295	.00005
89DIRECTLY ALLOCATED IMPORTS	0.000000			.71389	
90TRANSFERRED IMPORTS	0.000000			15.78374	
91BUSINESS TRAVEL, ENTRIENMT, GIFTS	13763.420450			2.17608	.00016
92OFFICE SUPPLIES.	3067.000000			.15646	.00005
93SCRAP, USED AND SECONDHAND GOODS	4063.067991			1.88719	.00046
CONSTRUCTION OF A 100 MW CR PLANT					

D. Industrial Effects

Tables I, II and III illustrate the results of the model applied to this bill of goods for a 100 MWe intermediate load CR plant. Table I presents the 93 industries of the I/O model along with the 1972 outputs of each industry, the bill of goods, the fraction of this with 1972 output, the total increase in demand, and the fraction of this with 1972 output. These results may be viewed as the effects on the 1972 U.S. economy if one CR plant came on line each year.

E. Employment

Table II lists the effects on employment of meeting this bill of goods. For 423 job classifications it presents the number of jobs in each classification in 1972, the number of jobs produced in directly meeting this bill of goods, the fraction and sum of this with 1972 totals, the total number of jobs produced in meeting the bill of goods, and the fraction and sum of this with 1972 totals. These jobs are estimates of the number of man years which would be required to produce the basic components of the CR plant. They do not include on-site construction work and labor involved in transportation. They include only those jobs which would contribute to building or manufacturing components for the plant which are already manufactured for other purposes or are similar to those manufactured for other purposes. The additional jobs which would be required for on-site assembly and construction cannot be estimated by the techniques used here, but can only be estimated by construction contractors and aerospace companies actually involved in building the plants. Unpublished estimates which we have seen suggest that only a small fraction of the total jobs

Table II. Employment Resulting from the Construction of a 100 MW<sub>e</sub> Central Receiver Power Plant  
(in thousands of man years).

JOB DESCRIPTION	NUMBER OF JOBS ARE IN THOUSANDS						
	(1) 1972 NUMBER OF JOBS	(2) JOB INCREASE FROM DIRECT INCREASED DEMAND	(3) (2)/(1)	(4) (2)+(1)	(5) JOB INCREASE FROM CUMULATIVE INCREASED DEMAND	(6) (5)/(1)	(7) (5)+(1)
1 TOTAL, ALL OCCUPATIONS	81701.000	5.909	.00006	81706.909	9.908	.00012	81716.908
2 ENGINEERS, AERO-ASTRONAUTIC	52.000	.000	.00001	52.000	.003	.00006	52.003
3 ENGINEERS, CHEMICAL	50.000	.005	.00010	50.005	.012	.00023	50.012
4 ENGINEERS, CIVIL	154.000	.004	.00003	154.004	.012	.00007	154.012
5 ENGINEERS, ELECTRICAL	287.000	.043	.00015	287.043	.074	.00026	287.074
6 ENGINEERS, INDUSTRIAL	170.000	.037	.00022	170.037	.058	.00034	170.058
7 ENGINEERS, MECHANICAL	191.000	.042	.00022	191.042	.064	.00034	191.064
8 ENGINEERS, METALLURGICAL	15.000	.005	.00034	15.005	.010	.00067	15.010
9 ENGINEERS, MINING	8.000	.000	.00001	8.000	.003	.00032	8.003
10 ENGINEERS, PETROLEUM	10.000	.000	.00001	10.000	.001	.00007	10.001
11 ENGINEERS, SALES	40.000	.009	.00022	40.009	.013	.00034	40.013
12 ENGINEERS, OTHER	124.000	.020	.00016	124.020	.032	.00026	124.032
13 AGRICULTURAL SCIENTISTS	13.000	.000	.00000	13.000	.000	.00002	13.000
14 ATMOSPHERIC, SPACE SCIENTISTS	7.000	.000	.00002	7.000	.000	.00006	7.000
15 BIOLOGICAL SCIENTISTS	36.000	.000	.00001	36.000	.001	.00002	36.001
16 CHEMISTS	119.000	.011	.00009	119.011	.027	.00022	119.027
17 GEOLOGISTS	25.000	.000	.00001	25.000	.002	.00009	25.002
18 MARINE SCIENTISTS	4.000	.000	.00001	4.000	.000	.00004	4.000
19 PHYSICISTS AND ASTRONOMERS	22.000	.002	.00007	22.002	.003	.00013	22.003
20 LIFE, PHYSICAL SCIENTISTS NEC	3.000	.000	.00006	3.000	.000	.00012	3.000
21 ACTUARIES	6.000	.000	.00000	6.000	.000	.00005	6.000
22 MATHEMATICIANS	6.000	.000	.00002	6.000	.000	.00007	6.000
23 STATISTICIANS	21.000	.001	.00004	21.001	.002	.00010	21.002
24 AGRI, BIOLOG TECH EXC HEALTH	41.000	.000	.00000	41.000	.001	.00002	41.001
25 CHEMICAL TECHNICIANS	77.000	.006	.00008	77.006	.015	.00019	77.015
26 DRAFTSMEN	286.000	.067	.00023	286.067	.100	.00035	286.100
27 ELECTRICAL, ELECTRONIC TECH	164.000	.025	.00016	164.025	.041	.00025	164.041
28 INDUSTRIAL ENGINEERING TECH	14.000	.003	.00023	14.003	.005	.00037	14.005
29 MATHEMATICAL TECHN	2.000	.000	.00002	2.000	.000	.00005	2.000
30 MECHANICAL ENGINEERING TECH	12.000	.002	.00018	12.002	.004	.00032	12.004
31 SURVEYORS	71.000	.000	.00000	71.000	.004	.00006	71.004
32 ENGINEERING, SCIENCE TECH NEC	160.000	.019	.00012	160.019	.034	.00022	160.034
33 CHIROPRACTORS	17.000	0.000	0.00000	17.000	.000	.00000	17.000
34 DENTISTS	107.000	.000	.00000	107.000	.000	.00000	107.000
35 DIETITIANS	33.000	.000	.00000	33.000	.000	.00000	33.000
36 OPTOMETRISTS	17.000	.000	.00000	17.000	.000	.00003	17.000
37 PHARMACISTS	126.000	.000	.00000	126.000	.006	.00004	126.006
38 PHYSICIANS, MD OSTEOPATHS	328.000	.000	.00000	328.000	.002	.00001	328.002
39 PODIATRISTS	6.000	0.000	0.00000	6.000	.000	.00002	6.000
40 REGISTERED NURSES	801.000	.003	.00000	801.003	.004	.00001	801.004
41 THERAPISTS	115.000	.000	.00000	115.000	.000	.00000	115.000
42 VETERINARIANS	23.000	.000	.00000	23.000	.000	.00002	23.000
43 OTHER MEDICAL AND HEALTH	0.000	0.000	0.00000	0.000	0.000	0.00000	0.000
44 CLINICAL LAB TECHNOL, TECH	143.000	.000	.00000	143.000	.001	.00001	143.001
45 DENTAL HYGIENISTS	22.000	.000	.00000	22.000	.000	.00000	22.000
46 HEALTH RECORD TECHNOL, TECH	12.000	.000	.00000	12.000	.000	.00000	12.000
47 RADIOLOGIC TECHNOL, TECH	68.000	.000	.00000	68.000	.000	.00000	68.000
48 THERAPY ASSISTANTS	3.000	.000	.00000	3.000	.000	.00001	3.000
49 OTHER HEALTH TECHNOL, TECH	67.000	.000	.00000	67.000	.001	.00001	67.001
50 AIRPLANE PILOTS	64.000	.001	.00002	64.001	.000	.00000	64.001

Table II. (continued)

51 AIR TRAFFIC CONTROLLERS	27.000	0.000	0.00000	27.000	0.000	0.00000	27.000
52 EMBALMERS	6.000	0.000	0.00000	6.000	0.000	0.00000	6.000
53 FLIGHT ENGINEERS	4.000	0.000	0.00000	4.000	0.000	0.00000	4.000
54 RADIO OPERATORS	37.000	0.000	0.00000	37.000	0.001	0.00004	37.001
55 TOOL PROGRAMMERS, NUMERICAL	2.000	0.001	0.00025	2.001	0.001	0.00039	2.001
56 OTHER TECHNICIANS EXC HEALTH	12.000	0.000	0.00007	12.000	0.001	0.00007	12.001
57 COMPUTER PROGRAMMERS	186.000	0.013	0.00007	186.013	0.027	0.00015	186.027
58 COMPUTER SYSTEMS ANALYSTS	74.000	0.005	0.00007	74.005	0.011	0.00015	74.011
59 OTHER COMPUTER SPECIALISTS	13.000	0.001	0.00006	13.001	0.002	0.00014	13.002
60 ECONOMISTS	68.000	0.006	0.00008	68.006	0.011	0.00017	68.011
61 POLITICAL SCIENTISTS	2.000	0.000	0.00001	2.000	0.000	0.00002	2.000
62 PSYCHOLOGISTS	50.000	0.000	0.00000	50.000	0.000	0.00001	50.000
63 SOCIOLOGISTS	4.000	0.000	0.00000	4.000	0.000	0.00002	4.000
64 URBAN AND REGIONAL PLANNERS	12.000	0.000	0.00000	12.000	0.000	0.00002	12.000
65 OTHER SOCIAL SCIENTISTS	6.000	0.000	0.00000	6.000	0.000	0.00000	6.000
66 ADULT EDUCATION TEACHERS	69.000	0.002	0.00002	69.002	0.003	0.00004	69.003
67 AGRICULTURE TEACHERS	8.000	0.000	0.00000	8.000	0.000	0.00000	8.000
68 ART, DRAMA, MUSIC TEACHERS	30.000	0.000	0.00000	30.000	0.000	0.00000	30.000
69 ATMOSPHERIC, EARTH, MARINE	7.000	0.000	0.00000	7.000	0.000	0.00000	7.000
70 BIOLOGY TEACHERS	23.000	0.000	0.00000	23.000	0.000	0.00000	23.000
71 BUSINESS, COMMERCE TEACHERS	12.000	0.000	0.00000	12.000	0.000	0.00000	12.000
72 CHEMISTRY TEACHERS	17.000	0.000	0.00000	17.000	0.000	0.00000	17.000
73 COACHES, PHYS ED TEACHERS	12.000	0.000	0.00000	12.000	0.000	0.00000	12.000
74 ECONOMICS TEACHERS	12.000	0.000	0.00000	12.000	0.000	0.00000	12.000
75 EDUCATION TEACHERS	15.000	0.000	0.00000	15.000	0.000	0.00000	15.000
76 ELEMENTARY SCHOOL TEACHERS	1251.000	0.000	0.00000	1251.000	0.000	0.00000	1251.000
77 ENGINEERING TEACHERS	22.000	0.000	0.00000	22.000	0.000	0.00000	22.000
78 ENGLISH TEACHERS	34.000	0.000	0.00000	34.000	0.000	0.00000	34.000
79 FOREIGN LANGUAGE TEACHERS	22.000	0.000	0.00000	22.000	0.000	0.00000	22.000
80 HEALTH SPECIALTIES TEACHERS	41.000	0.000	0.00000	41.000	0.000	0.00000	41.000
81 HISTORY TEACHERS	21.000	0.000	0.00000	21.000	0.000	0.00000	21.000
82 HOME ECONOMICS TEACHERS	5.000	0.000	0.00000	5.000	0.000	0.00000	5.000
83 LAW TEACHERS	3.000	0.000	0.00000	3.000	0.000	0.00000	3.000
84 MATHEMATICS TEACHERS	39.000	0.000	0.00000	39.000	0.000	0.00000	39.000
85 PHYSICS TEACHERS	15.000	0.000	0.00000	15.000	0.000	0.00000	15.000
86 PRESCHOOL, KINDERGARTEN	188.000	0.000	0.00000	188.000	0.000	0.00000	188.000
87 PSYCHOLOGY TEACHERS	23.000	0.000	0.00000	23.000	0.000	0.00000	23.000
88 SECONDARY SCHOOL TEACHERS	1114.000	0.000	0.00000	1114.000	0.000	0.00000	1114.000
89 SOCIOLOGY TEACHERS	11.000	0.000	0.00000	11.000	0.000	0.00000	11.000
90 SOCIAL SCIENCE TEACHERS NEC	15.000	0.000	0.00000	15.000	0.000	0.00000	15.000
91 MISC COLLEGE AND UNIVERSITY	27.000	0.000	0.00000	27.000	0.000	0.00000	27.000
92 COLLEGE, UNIVERSITY NEC	37.000	0.000	0.00000	37.000	0.000	0.00000	37.000
93 THEOLOGY TEACHERS	5.000	0.000	0.00000	5.000	0.000	0.00000	5.000
94 TRADE, INDUSTRIAL TEACHERS	4.000	0.000	0.00000	4.000	0.000	0.00000	4.000
95 TEACHERS NEC, EXC COLL, UNIVER	220.000	0.001	0.00000	220.001	0.004	0.00002	220.004
96 ACTORS	10.000	0.000	0.00000	10.000	0.000	0.00003	10.000
97 ATHLETES AND KINDRED WORKERS	78.000	0.000	0.00000	78.000	0.001	0.00002	78.001
98 AUTHORS	30.000	0.001	0.00003	30.001	0.003	0.00009	30.003
99 DANCERS	5.000	0.000	0.00000	5.000	0.000	0.00004	5.000
100 DESIGNERS	110.000	0.010	0.00009	110.010	0.019	0.00017	110.019
101 EDITORS AND REPORTERS	163.000	0.001	0.00001	163.001	0.011	0.00007	163.011
102 MUSICIANS AND COMPOSERS	121.000	0.000	0.00000	121.000	0.002	0.00002	121.002
103 PAINTERS AND SCULPTORS	129.000	0.002	0.00001	129.002	0.009	0.00007	129.009
104 PHOTOGRAPHERS	77.000	0.001	0.00002	77.001	0.004	0.00005	77.004
105 PUBLIC RELATIONS MEN, WRITERS	87.000	0.002	0.00003	87.002	0.007	0.00008	87.007
106 RADIO, TV ANNOUNCERS	22.000	0.000	0.00000	22.000	0.002	0.00010	22.002
107 WRITERS, ARTISTS, ENTERTAIN NEC	66.000	0.002	0.00004	66.002	0.004	0.00009	66.006
108 ACCOUNTANTS	714.000	0.043	0.00004	714.043	0.007	0.00014	714.007
109 ARCHITECTS	66.000	0.000	0.00000	66.000	0.004	0.00009	66.004
110 ARCHIVISTS AND CURATORS	7.000	0.000	0.00000	7.000	0.004	0.00001	7.004
111 CLERGYMEN	245.000	0.000	0.00000	245.000	0.001	0.00000	245.001
112 RELIGIOUS, EXC CLERGYMEN	47.000	0.000	0.00000	47.000	0.000	0.00001	47.000



Table II. (continued)

113 FARM MANAGEMENT ADVISORS	13.000	0.000	0.00000	13.000	.000	.00001	13.000
114 FORESTERS, CONSERVATIONISTS	48.000	.000	.00000	48.000	.002	.00004	48.002
115 HOME MANAGEMENT ADVISORS	8.000	.000	.00000	8.000	.000	.00003	8.000
116 JUDGES	16.000	0.000	0.00000	16.000	0.000	0.00000	16.000
117 LAWYERS	303.000	.001	.00000	303.001	.028	.00009	303.028
118 LIBRARIANS	151.000	.001	.00000	151.001	.002	.00001	151.002
119 OPERATIONS, SYSTEMS RESEARCH	111.000	.017	.00016	111.017	.029	.00026	111.029
120 PERSONNEL LABOR RELATIONS	310.000	.018	.00006	310.018	.041	.00013	310.041
121 RESEARCH WORKERS, NEC	86.000	.002	.00003	86.002	.006	.00007	86.006
122 RECREATION WORKERS	92.000	.000	.00000	92.000	.001	.00001	92.001
123 SOCIAL WORKERS	263.000	.000	.00000	263.000	.001	.00000	263.001
124 VOCATIONAL, ED COUNSELORS	134.000	.000	.00000	134.000	.000	.00000	134.000
125 BANK, FINANCIAL MANAGERS	427.000	.006	.00001	427.006	.026	.00006	427.026
126 CREDITMEN	71.000	.003	.00004	71.003	.007	.00010	71.007
127 BUYERS, SHIPPERS, FARM PROD	22.000	0.000	0.00000	22.000	.001	.00004	22.001
128 BUYERS, WHOLESALE, RETAIL	161.000	0.000	0.00000	161.000	.008	.00005	161.008
129 PURCHASING AGENTS, BUYERS, NEC	181.000	.034	.00019	181.034	.051	.00028	181.051
130 SALES MANAGER, RETAIL TRADE	296.000	0.000	0.00000	296.000	.015	.00005	296.015
131 SALES MANAGER, EXC RET TRADE	274.000	.027	.00010	274.027	.049	.00018	274.049
132 ASSESS, CONTROL, LOC PUB ADMIN	29.000	0.000	0.00000	29.000	0.000	0.00000	29.000
133 CONSTRUCTION INSPECTOR, PUB.	23.000	0.000	0.00000	23.000	0.000	0.00000	23.000
134 HEALTH ADMINISTRATORS	118.000	0.000	0.00000	118.000	.000	.00000	118.000
135 INSPECTORS, EXC CONSTRUCT PUB	97.000	0.000	0.00000	97.000	.000	.00000	97.000
136 OFFICIALS, ADMINS, PUB	309.000	.000	.00000	309.000	.000	.00000	309.000
137 POSTMASTERS AND MAIL SUPER	44.000	0.000	0.00000	44.000	.002	.00006	44.002
138 SCHOOL ADMIN, COLLEGE	83.000	0.000	0.00000	83.000	.000	.00000	83.000
139 SCHOOL ADMIN, ELEM, SECONDARY	221.000	0.000	0.00000	221.000	.000	.00000	221.000
140 FUNERAL DIRECTORS	40.000	0.000	0.00000	40.000	.000	.00000	40.000
141 MGRS, SUPERINTENDENTS, BLDG	136.000	.000	.00000	136.000	.004	.00003	136.004
142 OFFICE MANAGERS, NEC	315.000	.016	.00005	315.016	.036	.00011	315.036
143 OFFICRS, PILOTS, PURSERS, SHIP	30.000	.000	.00000	30.000	.002	.00006	30.002
144 OFFICIALS OF LODGES, UNIONS	80.000	0.000	0.00000	80.000	.000	.00000	80.000
145 RAILROAD CONDUCTORS	45.000	0.000	0.00000	45.000	.007	.00016	45.007
146 RESTAURANT, CAFE, BAR MGRS	494.000	.000	.00000	494.000	.023	.00005	494.023
147 OTHER MGRS, ADMINISTRATORS	4531.000	.239	.00005	4531.239	.522	.00012	4531.522
148 ADVERTISING AGENTS, SALESMEN	66.000	.001	.00001	66.001	.006	.00009	66.006
149 AUCTIONEERS	3.000	.000	.00000	3.000	.000	.00000	3.000
150 DEMONSTRATORS	64.000	.000	.00001	64.000	.004	.00006	64.004
151 HUCKSTERS AND PEDDLERS	230.000	0.000	0.00000	230.000	.012	.00005	230.012
152 INSURANCE AGENTS, BROKERS, ETC	441.000	0.000	0.00000	441.000	.018	.00004	441.018
153 NEWSBOYS	90.000	0.000	0.00000	90.000	.005	.00006	90.005
154 REAL ESTATE AGENTS, BROKERS	349.000	0.000	0.00000	349.000	.010	.00003	349.010
155 STOCK AND BOND SALESMEN	101.000	0.000	0.00000	101.000	.004	.00004	101.004
156 SALES REPRES, MFG	400.000	.075	.00019	400.075	.116	.00029	400.116
157 SALES REPRES, WHOLESALE TRADE	696.000	.000	.00000	696.000	.035	.00005	696.035
158 SALES CLERKS, RETAIL TRADE	2348.000	0.000	0.00000	2348.000	.118	.00005	2348.118
159 SALESMEN, RETAIL TRADE	430.000	0.000	0.00000	430.000	.022	.00005	430.022
160 SALESMEN, SERV AND CONSTR	136.000	.000	.00000	136.000	.008	.00006	136.008
161 SECRETARIES, LEGAL	109.000	.000	.00000	109.000	.011	.00010	109.011
162 SECRETARIES, MEDICAL	84.000	.000	.00000	84.000	.001	.00001	84.001
163 SECRETARIES, OTHER	2756.000	.142	.00005	2756.142	.293	.00011	2756.293
164 STENOGRAPHERS	125.000	.005	.00004	125.005	.011	.00009	125.011
165 TYPISTS	1021.000	.042	.00004	1021.042	.095	.00009	1021.095
166 BOOKKEEPING, BILLING OPERATORS	69.000	.003	.00004	69.003	.004	.00009	69.004
167 CALCULATING MACHINE OPERATORS	36.000	.001	.00004	36.001	.004	.00010	36.004
168 COMPUTER, PERIPHERAL EQUIP	196.000	.013	.00007	196.013	.028	.00014	196.028
169 DUPLICATING MACHINE OPERATORS	21.000	.001	.00007	21.001	.003	.00014	21.003
170 KEYPUNCH OPERATORS	283.000	.019	.00007	283.019	.040	.00014	283.040
171 TABULATING MACHINE OPERATORS	10.000	.001	.00009	10.001	.002	.00014	10.002
172 OTHER OFFICE MACHINE OPERATORS	59.000	.002	.00003	59.002	.006	.00005	59.006
173 BANK TELLERS	288.000	0.000	0.00000	288.000	.012	.00004	288.012
174 BILLING CLERKS	149.000	.011	.00007	149.011	.023	.00015	149.023

Table II. (continued)

175	BOOKKEEPERS	1584.000	.064	.00004	1584.064	.156	.00010	1584.156
176	CASHIERS	998.000	.001	.00000	998.001	.047	.00005	998.047
177	CLERICAL ASSIST, SOC WELFARE	4.000	0.000	0.00000	4.000	.000	.00000	4.000
178	CLERICAL SUPERVISORS, NEC	199.000	.006	.00003	199.006	.016	.00008	199.016
179	COLLECTORS, BILL AND ACCOUNT	60.000	.000	.00000	60.000	.004	.00006	60.004
180	COUNTER CLERKS, EXC FOOD	329.000	.010	.00003	329.010	.023	.00007	329.023
181	DISPATCHER, STARTER, VEHICLE	86.000	.002	.00002	86.002	.009	.00010	86.009
182	ENUMERATORS AND INTERVIEWERS	39.000	.000	.00000	39.000	.001	.00003	39.001
183	ESTIMATORS, INVESTIGATORS, NEC	348.000	.019	.00005	348.019	.039	.00011	348.039
184	EXPEDITORS, PROD CONTROLLERS	195.000	.046	.00023	195.046	.073	.00037	195.073
185	FILE CLERKS	272.000	.011	.00004	272.011	.026	.00010	272.026
186	INSURANCE ADJUST, EXAM	108.000	.000	.00000	108.000	.005	.00004	108.005
187	LIBRARY ATTENDANTS, ASSISTANT	137.000	.000	.00000	137.000	.001	.00001	137.001
188	MAIL CARRIERS, POST OFFICE	270.000	0.000	0.00000	270.000	.015	.00006	270.015
189	MAIL HANDLER, EXC POST OFFICE	128.000	.004	.00003	128.004	.012	.00009	128.012
190	MESSENGERS AND OFFICE BOYS	78.000	.001	.00001	78.001	.006	.00007	78.006
191	METER READERS, UTILITIES	33.000	0.000	0.00000	33.000	.003	.00009	33.003
192	PAYROLL, TIME KEEPING CLERKS	184.000	.024	.00013	184.024	.041	.00022	184.041
193	POSTAL CLERKS	281.000	0.000	0.00000	281.000	.016	.00006	281.016
194	PROOFREADERS	28.000	0.000	0.00000	28.000	.002	.00006	28.002
195	REAL ESTATE APPRAISERS	22.000	.000	.00000	22.000	.001	.00003	22.001
196	RECEPTIONISTS	436.000	.011	.00003	436.011	.025	.00006	436.025
197	SHIPPING, RECEIVING CLERKS	451.000	.066	.00015	451.066	.109	.00024	451.109
198	STATISTICAL CLERKS	299.000	.014	.00005	299.014	.035	.00012	299.035
199	STOCK CLERKS, STORE KEEPERS	511.000	.056	.00011	511.056	.097	.00019	511.097
200	TEACHERS AIDES, EXC MONITORS	206.000	0.000	0.00000	206.000	.000	.00000	206.000
201	TELEGRAPH MESSENGERS	1.000	0.000	0.00000	1.000	.000	.00000	1.000
202	TELEGRAPH OPERATORS	9.000	.000	.00000	9.000	.001	.00012	9.001
203	TELEPHONE OPERATORS	392.000	.006	.00002	392.006	.032	.00008	392.032
204	TICKET STATION, EXPRESS AGENTS	128.000	.000	.00000	128.000	.012	.00009	128.012
205	WEIGHERS	43.000	.005	.00011	43.005	.010	.00024	43.010
206	MISC CLERICAL WORKERS, NEC	1182.000	.033	.00003	1182.033	.084	.00007	1182.084
207	CARPENTERS	1027.000	.027	.00002	1027.027	.058	.00006	1027.056
208	CARPENTERS APPRENTICES	18.000	.000	.00002	18.000	.001	.00005	18.001
209	BRICKMASON AND STONEMASONS	170.000	.007	.00004	170.007	.017	.00010	170.017
210	BRICK, STONEMASON APPREN	6.000	.000	.00004	6.000	.001	.00009	6.001
211	BULLDOZER OPERATORS	140.000	.005	.00004	140.005	.017	.00012	140.017
212	CEMENT AND CONCRETE FINISHERS	79.000	.001	.00002	79.001	.003	.00004	79.003
213	ELECTRICIANS	469.000	.042	.00009	469.042	.085	.00016	469.085
214	ELECTRICIANS APPREN	25.000	.002	.00007	25.002	.004	.00015	25.004
215	EXCAVATING, GRADING, MACH OP	286.000	.004	.00001	286.004	.016	.00005	286.016
216	FLOOR LAYERS, EXC TILE SETTERS	19.000	.000	.00001	19.000	.001	.00005	19.001
217	PAINTERS, CONSTRUCTION, MAINT	426.000	.016	.00004	426.016	.031	.00007	426.031
218	PAINTER APPREN	2.000	.000	.00002	2.000	.000	.00006	2.000
219	PAPERHANGERS	15.000	.000	.00001	15.000	.000	.00003	15.000
220	PLASTERERS	28.000	.000	.00001	28.000	.001	.00003	28.001
221	PLASTERER APPREN	0.000	0.000	0.00000	0.000	0.000	0.00000	0.000
222	PLUMBERS AND PIPEFITTERS	370.000	.018	.00005	370.018	.041	.00011	370.041
223	PLUMBERS, PIPEFITTERS APPREN	19.000	.001	.00004	19.001	.002	.00009	19.002
224	ROOFERS AND SLATERS	85.000	.001	.00001	85.001	.002	.00003	85.002
225	STRUCTURAL METAL CRAFT	74.000	.028	.00038	74.028	.033	.00045	74.033
226	TILESETTERS	35.000	.000	.00001	35.000	.001	.00004	35.001
227	FOREMEN, NEC	1413.000	.210	.00015	1413.210	.367	.00026	1413.367
228	BLACKSMITHS	10.000	.001	.00010	10.001	.003	.00027	10.003
229	BOILERMAKERS	37.000	.018	.00048	37.018	.022	.00063	37.022
230	HEAT TREATERS, ANNEALERS, ETC	23.000	.012	.00034	23.012	.021	.00060	23.021
231	FORGEMEN AND HAMMERMEN	12.000	.012	.00106	12.012	.016	.00134	12.016
232	JOB AND DIE SETTERS, METAL	94.000	.087	.00093	94.087	.107	.00113	94.107
233	MACHINISTS	267.000	.152	.00042	267.152	.218	.00054	267.218
234	MACHINIST APPREN	10.000	.005	.00047	10.005	.007	.00067	10.007
235	MILLWRIGHTS	86.000	.022	.00027	86.022	.044	.00051	86.044
236	MOLDERS, METAL	52.000	.021	.00040	52.021	.045	.00066	52.045

Table II. (continued)

237	MOLDERS APPREN	1.000	.000	.00026	1.000	.001	.00072	1.001
238	PATTERN AND MODEL MAKERS	43.000	.012	.00029	43.012	.019	.00045	43.019
239	ROLLERS AND FINISHERS, METAL	17.000	.010	.00058	17.010	.020	.00115	17.020
240	SHEET METAL WORKERS, TINSMITHS	144.000	.059	.00041	144.059	.071	.00049	144.071
241	SHEET METAL APPREN	5.000	.002	.00045	5.002	.003	.00052	5.003
242	TOOL, DIE MAKERS	172.000	.100	.00058	172.100	.132	.00077	172.132
243	TOOL, DIE MAKER APPREN	12.000	.007	.00060	12.007	.010	.00080	12.010
244	AIR COND, HEATING, REFRIG	174.000	.008	.00005	174.008	.017	.00010	174.017
245	AIRCRAFT	123.000	.001	.00001	123.001	.009	.00007	123.009
246	AUTO ACCESSORIES INSTALR	10.000	.000	.00001	10.000	.001	.00006	10.001
247	AUTO BODY REPAIRMEN	161.000	.000	.00000	161.000	.008	.00005	161.008
248	AUTO MECHANICS	867.000	.010	.00001	867.010	.058	.00007	867.058
249	AUTO MECHANICS APPREN	5.000	.000	.00000	5.000	.000	.00006	5.000
250	DATA PROCESSING MACH REPAIRMEN	45.000	.002	.00005	45.002	.005	.00012	45.005
251	FARM IMPLEMENTS	47.000	.001	.00001	47.001	.003	.00007	47.003
252	HEAVY EQUIP MECH, INCL DIESEL	714.000	.122	.00017	714.122	.209	.00029	714.209
253	HOUSEHOLD APPLIANCE MECHANICS	132.000	.003	.00002	132.003	.011	.00009	132.011
254	LOOM FIXERS	18.000	.000	.00001	18.000	.001	.00004	18.001
255	OFFICE MACHINE REPAIRMEN	69.000	.001	.00002	69.001	.005	.00008	69.005
256	RADIO, TELEVISION REPAIRMEN	124.000	.002	.00001	124.002	.008	.00006	124.008
257	RAILROAD, CAR SHOP REPAIRMEN	55.000	.001	.00001	55.001	.010	.00018	55.010
258	MECHANICS EXC AUTO APPREN	10.000	.002	.00017	10.002	.003	.00033	10.003
259	OTHER MECHANICS AND REPAIRMEN	223.000	.014	.00006	223.014	.031	.00014	223.031
260	BOOKBINDERS	32.000	.000	.00000	32.000	.002	.00006	32.002
261	COMPOSITORS AND TYPESETTERS	170.000	.003	.00002	170.003	.015	.00009	170.015
262	ELECTROTYPERS, STEREOTYPERS	4.000	.000	.00002	4.000	.000	.00011	4.000
263	ENGRAVERS EXC PHOTOENGRAVERS	12.000	.002	.00017	12.002	.003	.00027	12.003
264	PHOTOENGRAVERS, LITHOGRAPHERS	39.000	.001	.00003	39.001	.004	.00010	39.004
265	PRESSMEN AND PLATE PRINTERS	142.000	.004	.00003	142.004	.015	.00010	142.015
266	PRESSMEN APPREN	3.000	.000	.00006	3.000	.000	.00013	3.000
267	PRINTING APPREN, EXC PRESS	7.000	.000	.00002	7.000	.001	.00008	7.001
268	ELECTRIC POWR LINEMEN, CABLEMEN	102.000	.000	.00000	102.000	.009	.00009	102.009
269	LOCOMOTIVE ENGINEERS	53.000	.001	.00002	53.001	.011	.00021	53.011
270	LOCOMOTIVE FIREMEN	15.000	.000	.00000	15.000	.003	.00017	15.003
271	POWER STATION OPERATORS	22.000	.001	.00005	22.001	.004	.00017	22.004
272	TELEPHONE INSTALLRS, REPAIRMEN	310.000	.000	.00000	310.000	.024	.00008	310.024
273	TELEPHONE LINEMEN, SPLICERS	67.000	.000	.00000	67.000	.005	.00008	67.005
274	BARBERS	114.000	.000	.00000	114.000	.004	.00003	114.004
275	CABINETMAKERS	60.000	.001	.00002	60.001	.004	.00006	60.004
276	CARPET INSTALLERS	62.000	.000	.00000	62.000	.002	.00004	62.002
277	CRANEMEN, DERRICKMEN, HOISTMEN	150.000	.042	.00028	150.042	.087	.00058	150.087
278	DECORATORS, WINDOW DRESSERS	87.000	.000	.00000	87.000	.005	.00006	87.005
279	DENTAL LABORATORY TECH	33.000	.000	.00000	33.000	.000	.00001	33.000
280	FURNITURE AND WOOD FINISH	27.000	.000	.00000	27.000	.001	.00005	27.001
281	FURRIERS	3.000	.000	.00001	3.000	.006	.00005	3.000
282	GLAZIERS	27.000	.002	.00007	27.002	.003	.00012	27.003
283	INSPECTORS, LOG AND LUMBER	23.000	.000	.00000	23.000	.002	.00008	23.002
284	INSPECTORS, OTHER	131.000	.008	.00006	131.008	.026	.00020	131.026
285	JEWELERS AND WATCHMAKERS	39.000	.000	.00000	39.000	.002	.00006	39.002
286	MILLERS, GRAIN, FLOUR, FEED	4.000	.000	.00000	4.000	.000	.00002	4.000
287	MOTION PICTURE PROJECTIONISTS	12.000	.000	.00000	12.000	.000	.00002	12.000
288	OPTICIANS, LENS GRINDR, POLISHR	30.000	.001	.00002	30.001	.002	.00007	30.002
289	PIANO, ORGAN TUNERS, REPAIRMEN	6.000	.000	.00000	6.000	.000	.00007	6.000
290	SHIPFITTERS	11.000	.000	.00002	11.000	.001	.00010	11.001
291	SHOE REPAIRMEN	22.000	.000	.00000	22.000	.000	.00001	22.000
292	SIGN PAINTERS AND LETTERS	21.000	.000	.00001	21.000	.002	.00010	21.002
293	STATIONARY ENGINEERS	190.000	.009	.00005	190.009	.025	.00013	190.025
294	STONE CUTTERS, STONE CARVERS	6.000	.001	.00019	6.001	.002	.00031	6.002
295	TAILORS	62.000	.000	.00000	62.000	.001	.00002	62.001
296	UPHOLSTERERS	66.000	.000	.00000	66.000	.003	.00005	66.003
297	CRAFTSMEN, KINDRED WORKRS, NEC	68.500	.007	.00010	68.507	.012	.00019	68.512
298	FORMER ARMED FORCES MEMBERS	300	.000	.00000	300	.000	.00000	300

Table II. (continued)

299 CRAFT APPREN, NEC	9.200	.001	.00010	9.201	.002	.00019	9.202
300 DRILL PRESS OPERATIVES	75.000	.043	.00057	75.043	.057	.00075	75.057
301 FURNACEMEN, SMELTERMEN, POURERS	70.000	.027	.00039	70.027	.064	.00092	70.064
302 GRINDING MACHINE OPERATIVES	130.000	.062	.00048	130.062	.095	.00073	130.095
303 HEATERS, METAL	3.000	.001	.00042	3.001	.003	.00103	3.003
304 LATHE, MILLING MACH OPERATIVES	123.000	.063	.00051	123.063	.087	.00071	123.087
305 METAL PLATERS	37.000	.020	.00054	37.020	.027	.00073	37.027
306 OTHER PRECISION MACH OPR	61.000	.052	.00085	61.052	.064	.00104	61.064
307 PUNCH STAMPING PRESS OPR	157.000	.160	.00102	157.160	.190	.00121	157.190
308 SOLDERERS	43.000	.013	.00030	43.013	.019	.00044	43.019
309 WELDERS AND FLAME CUTTERS	554.000	.250	.00045	554.250	.335	.00060	554.335
310 CARDING, LAPPING, COMBING	26.000	.000	.00000	26.000	.001	.00004	26.001
311 KNITTERS, LOOPERS, AND TOPPERS	41.000	0.000	0.00000	41.000	.001	.00001	41.001
312 SPINNERS, TWISTERS, WINDERS	168.000	.000	.00000	168.000	.057	.00004	168.007
313 WEAVERS	47.000	0.000	0.00000	47.000	.002	.00003	47.002
314 OTHER TEXTILE OPERATIVES	142.000	.000	.00000	142.000	.005	.00003	142.005
315 CHECKERS, EXAMINERS, ETC, MFG	685.000	.204	.00030	685.204	.298	.00043	685.298
316 GRADERS AND SORTERS, MFG	44.000	.005	.00011	44.005	.008	.00018	44.008
317 MEAT WRAPPERS, RETAIL TRADE	50.000	0.000	0.00000	50.000	.003	.00005	50.003
318 PACKER, WRAPPER, EX MEAT, PRODUCE	647.000	.066	.00010	647.066	.112	.00017	647.112
319 PROD GRDR, PACKER, EXC FACT, FARM	35.000	0.000	0.00000	35.000	.002	.00005	35.002
320 ASBESTOS, INSULATION WORKERS	30.000	.001	.00003	30.001	.002	.00007	30.002
321 ASSEMBLERS	1017.000	.319	.00031	1017.319	.447	.00044	1017.447
322 BLASTERS AND POWDERMEN	8.000	.000	.00002	8.000	.002	.00023	8.002
323 BOTTLING, CANNING OPERATIVES	55.000	.000	.00000	55.000	.001	.00002	55.001
324 CHAINMEN, ROOMEN, AXMEN SURVEYNG	17.000	.000	.00000	17.000	.001	.00007	17.001
325 CLOTHING IRONERS AND PRESSERS	164.000	.000	.00000	164.000	.001	.00001	164.001
326 CUTTING OPERATIVES, NEC	238.000	.052	.00022	238.052	.082	.00035	238.082
327 DRESSMAKER, SEAMSTRESS, EXC FACT	132.000	0.000	0.00000	132.000	.004	.00003	132.004
328 DRILLERS, EARTH	50.000	.005	.00011	50.005	.012	.00024	50.012
329 DRY WALL INSTALLERS, LATHES	83.000	.000	.00001	83.000	.002	.00003	83.002
330 DYERS	29.000	.000	.00001	29.000	.001	.00005	29.001
331 FILER, POLISHER, SANDER, BUFFER	122.000	.041	.00033	122.041	.057	.00047	122.057
332 GARAGE WORKERS, GAS STAT ATTEN	502.000	.000	.00000	502.000	.026	.00005	502.026
333 LAUNDRY, DRY CLEAN OP, NEC	165.000	.000	.00000	165.000	.001	.00000	165.001
334 MEAT CUTTERS, BUTCHERS, EXC MFG	201.000	0.000	0.00000	201.000	.010	.00005	201.010
335 MEAT CUTTERS, BUTCHERS	89.000	.000	.00000	89.000	.001	.00001	89.001
336 MILLINERS	0.000	0.000	0.00000	0.000	0.000	0.00000	0.000
337 MINE OPERATIVES, NEC	142.000	.000	.00000	142.000	.035	.00025	142.035
338 MIXING OPERATIVES	99.000	.012	.00012	99.012	.023	.00023	99.023
339 OILERS, GREASERS, EXC AUTO	46.000	.006	.00012	46.006	.013	.00027	46.013
340 PAINTERS, MFG ARTICLES	178.000	.052	.00029	178.052	.072	.00041	178.072
341 PHOTOGRAPHIC PROCESS WORKERS	81.000	.004	.00005	81.004	.010	.00012	81.010
342 RIVETERS AND FASTENERS	34.000	.009	.00026	34.009	.013	.00037	34.013
343 SAILORS AND DECKHANDS	21.000	.000	.00000	21.000	.001	.00007	21.001
344 SAWYERS	121.000	.010	.00008	121.010	.021	.00018	121.021
345 SEWERS AND STITCHERS	936.000	.003	.00000	936.003	.017	.00007	936.017
346 SHOEMAKING MACHINE OPR	76.000	.000	.00000	76.000	.001	.00001	76.001
347 STATIONARY FIREMEN	81.000	.007	.00009	81.007	.015	.00019	81.015
348 WINDING OPERATIVES, NEC	73.000	.027	.00037	73.027	.042	.00057	73.042
349 MISC MACH OPERATIVES	1306.600	.253	.00019	1306.853	.438	.00034	1307.038
350 OPERATIVES, NEC	1107.400	.172	.00016	1107.572	.305	.00028	1107.705
351 BOATMEN AND CANALMEN	6.000	.000	.00001	6.000	.000	.00007	6.000
352 BUS DRIVERS	252.000	.000	.00000	252.000	.008	.00003	252.008
353 CONDUCTORS, MOTORMEN, URBAN RAIL	14.000	.000	.00000	14.000	.000	.00003	14.000
354 DELIVERY AND ROUTEMEN	892.000	.014	.00002	892.014	.060	.00007	892.060
355 FORK LIFT, TOW MOTOR OPR	303.000	.065	.00021	303.065	.105	.00035	303.105
356 MOTORMEN, MINE, FACT, LOGGING	11.000	.001	.00008	11.001	.005	.00045	11.005
357 PARKING ATTENDANTS	33.000	.000	.00000	33.000	.001	.00004	33.001
358 RAILROAD BRAKEMEN	45.000	.001	.00002	45.001	.005	.00020	45.005
359 RAILROAD SWITCHMEN	47.000	.001	.00003	47.001	.010	.00022	47.010
360 TAXICAB DRIVERS, CHAUFFEURS	166.000	.001	.00001	166.001	.004	.00004	166.004

Table II. (continued)

361 TRUCK DRIVERS	1441.000	.048	.00003	1441.048	.184	.00013	1441.184
362 CHAMBERMAID, MAID, EXC PRIV	187.000	.000	.00000	187.000	.001	.00001	187.001
363 CLEANERS AND CHARWOMEN	668.000	.015	.00002	668.015	.044	.00007	668.044
364 JANITORS AND SEXTONS	1218.000	.057	.00005	1218.057	.119	.00010	1218.119
365 BARTENDERS	201.000	0.000	0.00000	201.000	.009	.00004	201.009
366 BUSBOYS	139.000	.000	.00000	139.000	.005	.00004	139.005
367 COOKS, EXC PRIVATE	866.000	.001	.00000	866.001	.031	.00004	866.031
368 DISHWASHERS	218.000	.000	.00000	218.000	.008	.00003	218.008
369 FOOD COUNTER, FOUNTAIN WORKERS	307.000	.001	.00000	307.001	.011	.00004	307.011
370 WAITERS	1124.000	.001	.00000	1124.001	.051	.00005	1124.051
371 FOOD WORKERS, NEC, EXC PRIVATE	408.000	.001	.00000	408.001	.010	.00002	408.010
372 DENTAL ASSISTANTS	94.000	.000	.00000	94.000	.000	.00000	94.000
373 HEALTH AIDES, EXCEPT NURSING	148.000	.000	.00000	148.000	.001	.00000	148.001
374 HEALTH TRAINEES	9.000	0.000	0.00000	9.000	.000	.00000	9.000
375 LAY MIDWIVES	0.000	0.000	0.00000	0.000	0.000	0.00000	0.000
376 NURSES AIDES, ORDERLIES	912.000	.000	.00000	912.000	.003	.00000	912.003
377 PRACTICAL NURSES	343.000	.000	.00000	343.000	.001	.00000	343.001
378 AIRLINE STEWARDESSES	31.000	0.000	0.00000	31.000	.003	.00008	31.003
379 ATTN, RECREATION, AMUSEMENT	125.000	.000	.00000	125.000	.002	.00002	125.002
380 ATTN, PERSONAL SERVICE, NEC	83.000	.001	.00001	83.001	.003	.00003	83.003
381 BAGGAGE PORTERS AND BELLMOPS	21.000	.000	.00000	21.000	.001	.00003	21.001
382 BARBERS	157.000	.000	.00000	157.000	.001	.00000	157.001
383 BOARDING, LODGING HOUSEKEEPERS	12.000	0.000	0.00000	12.000	.000	.00000	12.000
384 BOOTBLACKS	5.000	0.000	0.00000	5.000	.000	.00001	5.000
385 CHILD CARE WORKERS, EXC PRIVATE	356.000	.000	.00000	356.000	.002	.00000	356.002
386 ELEVATOR OPERATORS	41.000	.001	.00003	41.001	.003	.00006	41.003
387 HAIRDRESSERS, COSMETOLOGISTS	498.000	.000	.00000	498.000	.003	.00001	498.003
388 HOUSEKEEPERS, EXC PRIVATE	117.000	.000	.00000	117.000	.002	.00002	117.002
389 PERSONAL SERVICE APPRN	3.000	.000	.00000	3.000	.000	.00001	3.000
390 SCHOOL MONITORS	48.000	0.000	0.00000	48.000	.000	.00000	48.000
391 USHERS, RECREATION, AMUSEMENT	11.000	0.000	0.00000	11.000	.000	.00002	11.000
392 WELFARE SERVICE AIDES	34.000	0.000	0.00000	34.000	.000	.00000	34.000
393 CROSSING GUARD, BRIDGETENDERS	49.000	.000	.00000	49.000	.001	.00001	49.001
394 FIREMEN, FIRE PROTECTION	200.000	.001	.00000	200.001	.001	.00001	200.001
395 GUARDS AND WATCHMEN	412.000	.020	.00005	412.020	.051	.00012	412.051
396 MARSHALS AND CONSTABLES	8.000	0.000	0.00000	8.000	0.000	0.00000	8.000
397 POLICEMEN AND DETECTIVES	416.000	.000	.00000	416.000	.002	.00001	416.002
398 SHERIFFS AND BAILIFFS	59.000	0.000	0.00000	59.000	0.000	0.00000	59.000
399 CHILD CARE WORKERS	543.000	0.000	0.00000	543.000	0.000	0.00000	543.000
400 COOKS, PRIVATE	40.000	0.000	0.00000	40.000	0.000	0.00000	40.000
401 HOUSEKEEPERS, PRIVATE	112.000	0.000	0.00000	112.000	0.000	0.00000	112.000
402 LAUNDRESSES, PRIVATE	29.000	0.000	0.00000	29.000	0.000	0.00000	29.000
403 MAIDS, SERVANTS, PRIVATE	713.000	0.000	0.00000	713.000	0.000	0.00000	713.000
404 ANIMAL CARETAKERS, EXC FARM	80.000	.000	.00000	80.000	.002	.00002	80.002
405 CARPENTERS, HELPERS	125.000	.003	.00002	125.003	.007	.00006	125.007
406 CONSTR LABR, EXC CARPENTER HELP	818.000	.014	.00007	818.014	.039	.00005	818.039
407 FISHERMEN AND OYSTERMEN	36.000	0.000	0.00000	36.000	.002	.00006	36.002
408 FREIGHT, MATERIAL HANDLERS	761.000	.084	.00011	761.084	.188	.00022	761.188
409 GARBAGE COLLECTORS	85.000	.000	.00000	85.000	.005	.00005	85.005
410 GARDENRS, GROUNDKEEPR, EXC FARM	544.000	.002	.00000	544.002	.010	.00002	544.010
411 LONGSHOREMEN AND STEVEDORES	53.000	.000	.00000	53.000	.004	.00007	53.004
412 LUMBERMEN, RAFTSMEN, WOODCHOPPERS	81.000	.000	.00000	81.000	.006	.00008	81.006
413 STOCK HANDLERS	723.000	.023	.00003	723.023	.063	.00009	723.063
414 TEAMSTERS	7.000	.000	.00000	7.000	.001	.00015	7.001
415 VEHICLE WASHR, EQUIP CLEANERS	176.000	.013	.00007	176.013	.026	.00015	176.026
416 WAREHOUSEMEN, NEC	150.000	.005	.00003	150.005	.014	.00009	150.014
417 OTHER LABORERS	580.000	.097	.00017	580.097	.202	.00035	580.202
418 FARMERS (OWNERS AND TENANTS)	1658.000	0.000	0.00000	1658.000	.022	.00001	1658.022
419 FARM MANAGERS	30.000	0.000	0.00000	30.000	.000	.00001	30.000
420 FARM FOREMEN	28.000	0.000	0.00000	28.000	.000	.00001	28.000
421 FARM LABORERS, WAGE WRKRS	886.000	0.000	0.00000	886.000	.012	.00001	886.012
422 FARM LABORERS, UNPAID FAMILY	455.000	0.000	0.00000	455.000	.006	.00001	455.006

Table II. (continued)

423 FARM LABORERS, SELF-EMPL CONSTRUCTION OF A 100 MW CR PLANT.	11.000	0.000	0.00000	11.000	000	.00002	11.000
--	--------	-------	---------	--------	-----	--------	--------

would involve on-site construction and assembly, so that we view the above estimates as reasonable approximations for the entire plant. Figure III-1 shows graphically the job data for direct increase and for the most affected occupations. Figure III-2 shows the same for the cumulative increase. Topping the list in Figure III-2 are managers and administrators, followed by assemblers, machine operators, and foremen. A total of about 10,000 man years would be required for a 100 MWe solar power plant, which should be an underestimate because of the above mentioned reasons, but does not include any labor reductions which might be realized by mass production techniques.

A comparison can be made of the labor intensiveness of the CR plant with, for example, a coal-fired plant. Data on coal plants (with SO<sub>2</sub> removal) was taken from the Bechtel data base (Sathaye, 1977; Bechtel, 1975). This data was used to form a bill of goods for our model, and the employment model was run. Coal mining was included. The number of man years needed to build such a coal plant which was an energy equivalent of a 100 MW<sub>e</sub> CR plant over its lifetime was 3,900. Thus the coal plant required only 39% of the labor of the CR plant for the same energy output. The number of man years per million dollars of investment was greater for the solar plant (60.6 man years) than for the coal plant (51.7 man years) so the the CR is more labor intensive than coal both on a per energy output basis and on a per unit capital basis. Oil and natural gas generation are considerably less labor intensive than coal. It must again be remembered that mass production techniques may make the CR less labor intensive.

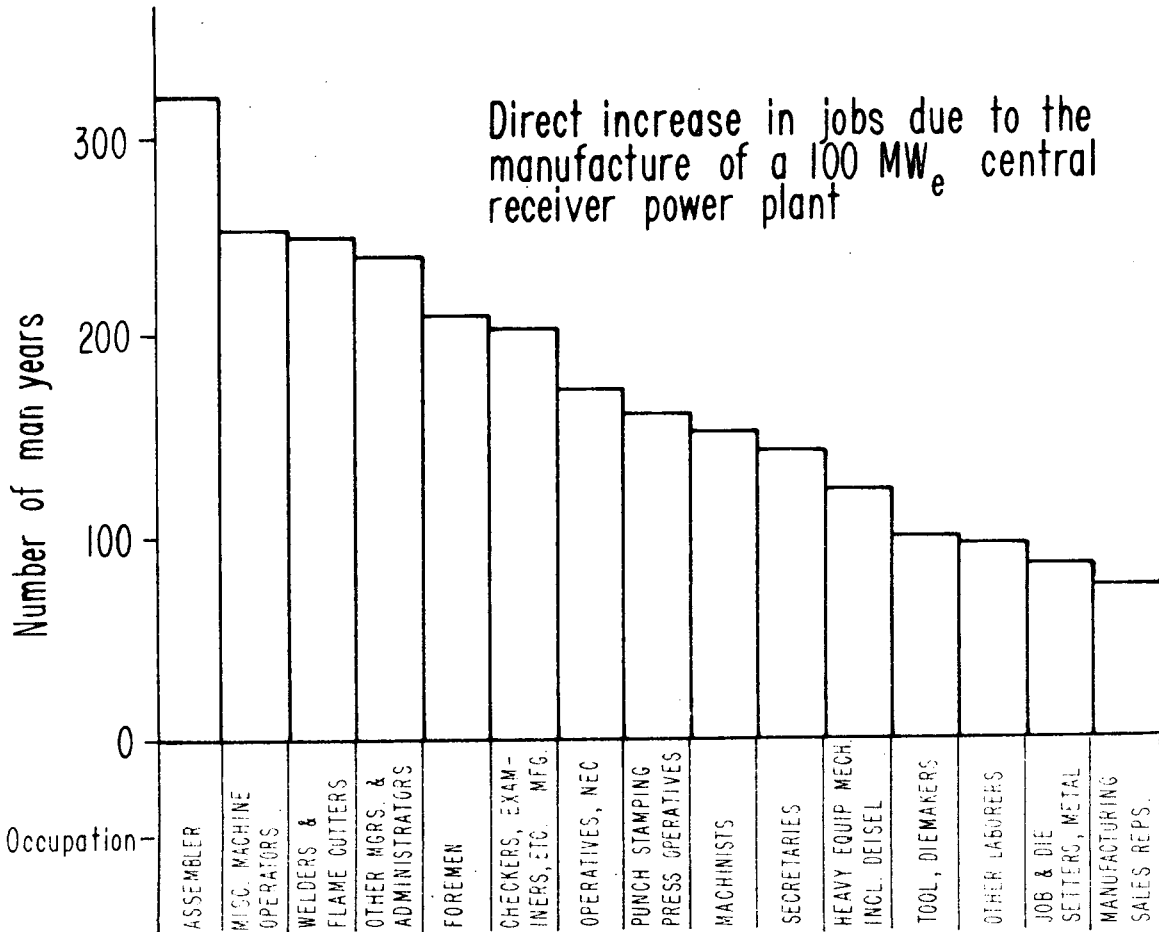

XBL 775-990

Fig. III-1



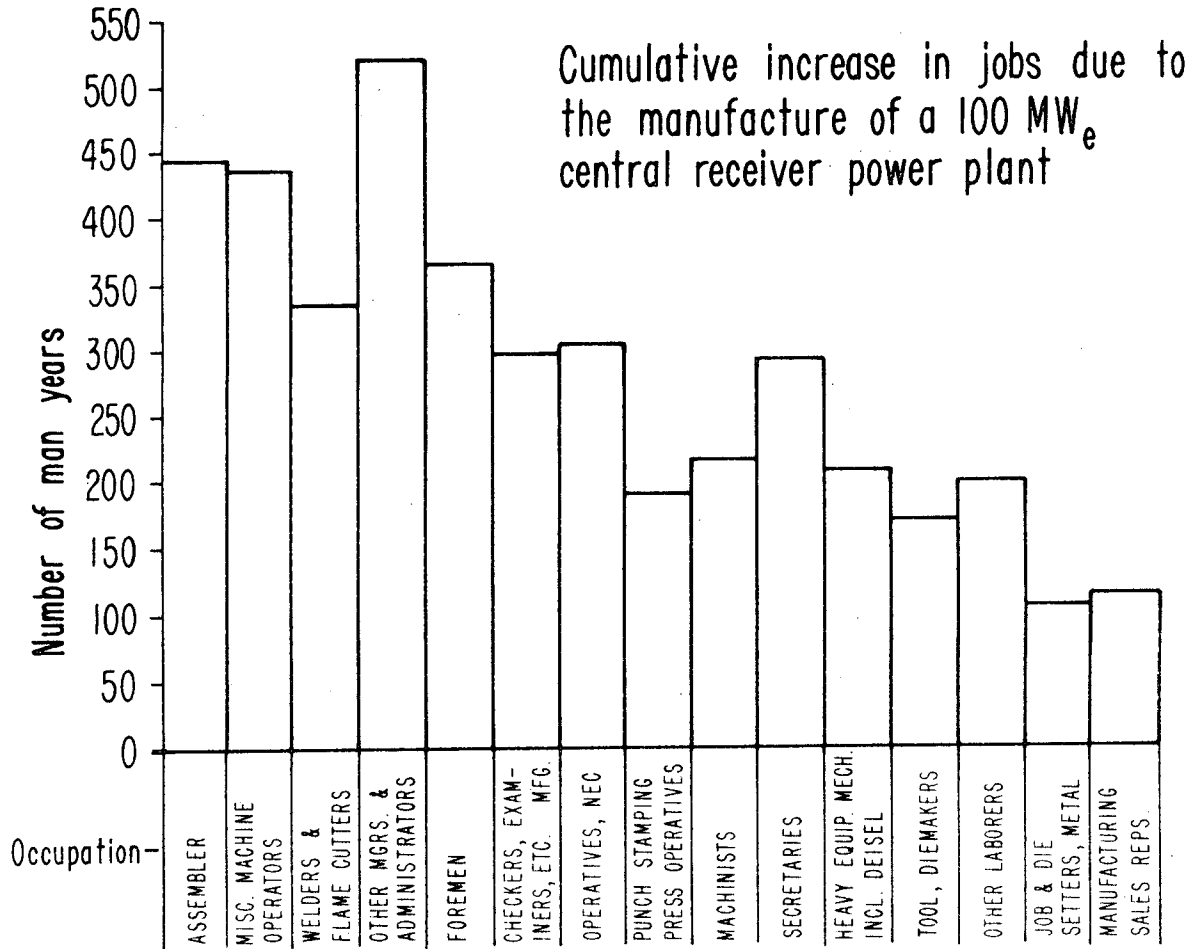

XBL 775-989

Fig. III-2

## F. Effluents

Table III lists 43 major effluents, their industrial outputs based on 1972 gross output if 1990 EPA standards were applied to the industries, the effluent increases resulting from direct and cumulative demand increases, and the fractional increases. The second column should not be misinterpreted as actual 1972 totals, since more stringent emission standards have been applied in arriving at it. Also, this table contains only industrial pollution.

For the sake of comparison, a calculation was performed which provides the effluents which would have been produced by the average 1972 generator stock (which is almost entirely fossil fuel) assuming that 1990 EPA standards were met, and for an amount of energy generation equal to the total generating capability of the central receiver plant over its lifetime. The following assumptions were made in estimating this generation capability. The solar plant will last about 30 years. It will generate about 1300 MWh/day, and is assumed to be operative for 75% of the days, the rest of the time being out for maintenance or forced outage. Thus a total of about  $1.0 \times 10^7$  MWh would be generated over the plants lifetime. At 1972 rates for electricity of \$.0177/kWh, this much energy would have represented a demand on the electric utilities of about 190 million dollars. Taking this figure as a direct increase, the cumulative effluents were calculated using the model. The results are shown in Table IV. Air pollutants are released mainly during the operation of the power plants. Effluents resulting from the construction of the utility owned generator stock are treated incorrectly by this method, but the error should be insignificant for the major air pollutants. Figure III-3 shows a graphical comparison

Table III. Effluents Associated with Manufacture of Component Parts for 100 MW<sub>e</sub> Central Receiver Power Plant (assuming 1990 EPA pollution standards).

EFFLUENT	UNITS ARE TONS					
	(1) 1972 NET EFFLUENTS (1990 EPA STANDARDS)	(2) EFFLUENT INCREASE FROM DIRECT INCREASED DEMAND	(3) (2)/(1)	(4) EFFLUENT INCREASE FROM CUMULATIVE INCREASED DEMAND	(5) (4)/(1)	
1 PARTICULATES	NOT APPLICABLE	.26302589E+07	.54488587E+03	.207E-03	.98119221E+03	.373E-03
2 ARSENIC	NOT APPLICABLE	.42765446E+02	G.	G.	.43641192E-02	.102E-03
3 ASBESTOS	NOT APPLICABLE	.11159040E+04	.30422873E+00	.273E-03	.45315896E+00	.406E-03
4 BERYLLIUM	NOT APPLICABLE	.10056584E+02	G.	G.	.10248414E-02	.102E-03
5 CADMIUM	NOT APPLICABLE	.69836200E-02	G.	G.	.39795411E-05	.576E-03
6 CHROMIUM	NOT APPLICABLE	.64002080E+03	G.	G.	.65083978E-01	.102E-03
7 FLUORINE	NOT APPLICABLE	.39874788E+04	.16733963E+00	.420E-04	.64206368E+00	.161E-03
8 LEAD	NOT APPLICABLE	.13127313E+04	G.	G.	.71291156E+00	.543E-03
9 SELENIUM	NOT APPLICABLE	.47246989E+02	G.	G.	.48048173E-02	.102E-03
10 VANADIUM	NOT APPLICABLE	.12739716E+03	G.	G.	.12955070E-01	.102E-03
11 ZINC	NOT APPLICABLE	.25371196E+04	G.	G.	.14457505E+01	.576E-03
12 SULFUR OXIDES	NOT APPLICABLE	.69532827E+07	.19218752E+03	.276E-04	.11047411E+04	.159E-03
13 NITROGEN OXIDES	NOT APPLICABLE	.68968696E+07	.12785693E+03	.185E-04	.90358845E+03	.131E-03
14 HYDROCARBONS	NOT APPLICABLE	.53964673E+06	.22815856E+02	.423E-04	.93064931E+02	.172E-03
15 CARBON MONOXIDE	NOT APPLICABLE	.53117685E+07	.16757357E+04	.315E-03	.52764663E+04	.993E-03
16 OTHER GASES AND MISTS	NOT APPLICABLE	.90437000E+04	.63202270E+00	.699E-04	.19897704E+01	.226E-03
17 CHLORINE	NOT APPLICABLE	.39457575E+04	.63391918E+00	.161E-03	.12974449E+01	.329E-03
18 MERCURY	NOT APPLICABLE	.26074086E+03	.11699128E-01	.449E-04	.43053000E-01	.165E-03
19 BIOLOGICAL OXYGEN DEMAND	NOT APPLICABLE	.34770941E+06	.19166543E+01	.551E-05	.28252059E+02	.813E-04
20 CHEMICAL OXYGEN DEMAND	NOT APPLICABLE	.10283813E+07	.19820195E+02	.193E-04	.10040639E+03	.976E-04
21 SUSPENDED SOLIDS	NOT APPLICABLE	.26493663E+06	.65917940E+01	.249E-04	.40669759E+02	.154E-03
22 PHENOLS	NOT APPLICABLE	.16252648E+03	.20054424E-01	.123E-03	.61155471E-01	.376E-03
23 DISSOLVED SOLIDS	NOT APPLICABLE	.52814312E+07	.56515450E+03	.107E-03	.13360577E+04	.253E-03
24 ALUMINUM	G.	G.	G.	G.	G.	G.
25 ARSENIC	NOT APPLICABLE	.14031212E+01	G.	G.	.79955360E-03	.576E-03
26 CADMIUM	NOT APPLICABLE	.24534815E+01	G.	G.	.13980902E-02	.576E-03
27 CHROMIUM	NOT APPLICABLE	.25190514E+03	.71282034E-02	.283E-04	.41072481E-01	.163E-03
28 COPPER	NOT APPLICABLE	.61185643E+03	.42513243E-02	.695E-05	.68239103E-01	.112E-03
29 CYANIDE	NOT APPLICABLE	.81279416E+02	.28957115E-01	.356E-03	.91111688E-01	.112E-03
30 FERROUS METALS	NOT APPLICABLE	.28455341E+05	.33296910E+00	.117E-04	.37664180E+01	.132E-03
31 FLUORINE	NOT APPLICABLE	.18655577E+04	.53562704E+00	.287E-03	.18935839E+01	.102E-02
32 LEAD	NOT APPLICABLE	.19883683E+02	.36375474E-02	.183E-03	.84751008E-02	.424E-03
33 MERCURY	NOT APPLICABLE	.16716387E+00	.26180383E-04	.157E-03	.55980847E-04	.335E-03
34 MISC NONFERROUS METALS	NOT APPLICABLE	.91255350E+02	.22557895E-01	.357E-03	.10248348E+00	.112E-02
35 SELENIUM	NOT APPLICABLE	.27501200E+01	G.	G.	.15671265E-02	.576E-03
36 ZINC	NOT APPLICABLE	.47602309E+03	.58154408E-02	.133E-04	.72656663E-01	.167E-03
37 NUTRIENTS	NOT APPLICABLE	.20458955E+05	.32613179E+01	.159E-03	.67005460E+01	.728E-03
38 PHOSPHATES	NOT APPLICABLE	.29927985E+02	.10677645E-01	.357E-03	.33610349E-01	.112E-02
39 ACIDS	NOT APPLICABLE	.77025000E+01	.12374715E-02	.161E-03	.25727378E-02	.329E-03
40 BASES	NOT APPLICABLE	.24314021E+05	.25248212E+01	.104E-03	.64352636E+01	.265E-02
41 OILS AND GREASES	NOT APPLICABLE	.17142919E+05	.26122211E+01	.152E-03	.68781665E+01	.401E-03
42 WASTE WATER	NOT APPLICABLE	.25601014E+07	.38162323E+03	.149E-03	.13518182E+04	.529E-03
43 INDUSTRIAL SLUDGE	NOT APPLICABLE	.68746292E+06	G.	G.	.44979144E+02	.649E-04

Table IV. Effluent Release from 1972 Average Generator in Producing Energy Equivalent of 100 MW<sub>e</sub> Central Receiver Plant.

EFFLUENT		UNITS ARE TONS					
		(1)	(2)	(3)	(4)	(5)	
		1972 NET EFFLUENTS (1990 EPA STANDARDS)	EFFLUENT INCREASE FROM DIRECT INCREASE DEMAND	(2)/(1)	EFFLUENT INCREASE FROM CUMULATIVE INCREASED DEMAND	(4)/(1)	
1	PARTICULATES	NOT APPLICABLE	.26302589E+07	.16982365E+04	.646E-03	20451004E+04	.778E-03
2	ARSENIC	.42765446E+02	.24949249E+00	.583E-02	.28516573E+00	.667E-02	
3	ASBESTOS	.11159040E+04	0.	0.	.37143794E-01	.333E-04	
4	BERYLLIUM	.10056584E+02	.58687438E-01	.584E-02	.67078649E-01	.667E-02	
5	CADMIUM	.69836200E-02	0.	0.	.24806217E-06	.355E-04	
6	CHROMIUM	.64002080E+03	.37367170E+01	.584E-02	.42709875E+01	.667E-02	
7	FLUORINE	.39874788E+04	.17199388E+02	.431E-02	.19722152E+02	.495E-02	
8	LEAD	.13127313E+04	.43817118E+00	.334E-03	.54478343E+00	.415E-03	
9	SELENIUM	.47246989E+02	.27584513E+00	.584E-02	.31528509E+00	.667E-02	
10	VANADIUM	.12739716E+03	.74379948E+00	.584E-02	.85014686E+00	.667E-02	
11	ZINC	.25371196E+04	0.	0.	.90119936E-01	.355E-04	
12	SULFUR OXIDES	NOT APPLICABLE	.69532827E+07	.21503989E+05	.309E-02	.24875138E+05	.358E-02
13	NITROGEN OXIDES	NOT APPLICABLE	.68968696E+07	.31839667E+05	.462E-02	.36519628E+05	.530E-02
14	HYDROCARBONS	NOT APPLICABLE	.53964673E+06	.41215967E+03	.764E-03	.51378425E+03	.952E-03
15	CARBON MONOXIDE	NOT APPLICABLE	.53117685E+07	.13628801E+04	.257E-03	.18004446E+04	.319E-03
16	OTHER GASES AND MISTS	NOT APPLICABLE	.90437000E+04	0.	0.	.40879938E+00	.452E-04
17	CHLORINE	.39457575E+04	0.	0.	.24100490E+00	.611E-04	
18	MERCURY	.26074086E+03	.10971999E+01	.421E-02	.12585234E+01	.483E-02	
19	BIOLOGICAL OXYGEN DEMAND	NOT APPLICABLE	.34770941E+06	0.	0.	.10320511E+02	.297E-04
20	CHEMICAL OXYGEN DEMAND	NOT APPLICABLE	.10283813E+07	0.	0.	.30897488E+02	.300E-04
21	SUSPENDED SOLIDS	NOT APPLICABLE	.26493663E+06	0.	0.	.93320640E+01	.352E-04
22	PHENOLS	.16252648E+03	0.	0.	.66409107E-02	.409E-04	
23	DISSOLVED SOLIDS	NOT APPLICABLE	.52814312E+07	.10297235E+05	.195E-02	.11984381E+05	.227E-02
24	ALUMINUM	0.	0.	0.	0.	0.	
25	ARSENIC	.14031212E+01	0.	0.	.49839666E-04	.355E-04	
26	CADMIUM	.24534815E+01	0.	0.	.87149063E-04	.355E-04	
27	CHROMIUM	.25190514E+03	.94831209E+00	.376E-02	.10854918E+01	.431E-02	
28	COPPER	.61185643E+03	.34174746E+01	.559E-02	.39079458E+01	.639E-02	
29	CYANIDE	.81279416E+02	0.	0.	.34674888E-02	.427E-04	
30	FERROUS METALS	.28455341E+05	.15957714E+03	.561E-02	.18244749E+03	.641E-02	
31	FLUORINE	.18655577E+04	0.	0.	.76913711E-01	.412E-04	
32	LEAD	.19883683E+02	0.	0.	.11662568E-02	.587E-04	
33	MERCURY	.16716387E+00	0.	0.	.10102758E-04	.604E-04	
34	MISC NONFERROUS METALS	.91255350E+02	0.	0.	.38886791E-02	.426E-04	
35	SELENIUM	.27501200E+01	0.	0.	.97685837E-04	.355E-04	
36	ZINC	.43602309E+03	.18396574E+01	.422E-02	.21069900E+01	.483E-02	
37	NUTRIENTS	NITRATES	.20458955E+05	0.	0.	.12372781E+01	.605E-04
38	PHOSPHATES	.29927985E+02	0.	0.	.12753261E-02	.426E-04	
39	ACIDS	NOT APPLICABLE	.77025000E+01	0.	0.	.47044486E-03	.611E-04
40	BASES	NOT APPLICABLE	.24314021E+05	0.	0.	.10436482E+01	.437E-04
41	OILS AND GREASES	NOT APPLICABLE	.17142919E+05	0.	0.	.75903806E+00	.443E-04
42	WASTE WATER	NOT APPLICABLE	.25601014E+07	0.	0.	.11208050E+03	.438E-04
43	INDUSTRIAL SLUDGES	NOT APPLICABLE	.68746292E+06	0.	0.	.88055569E+02	.128E-03

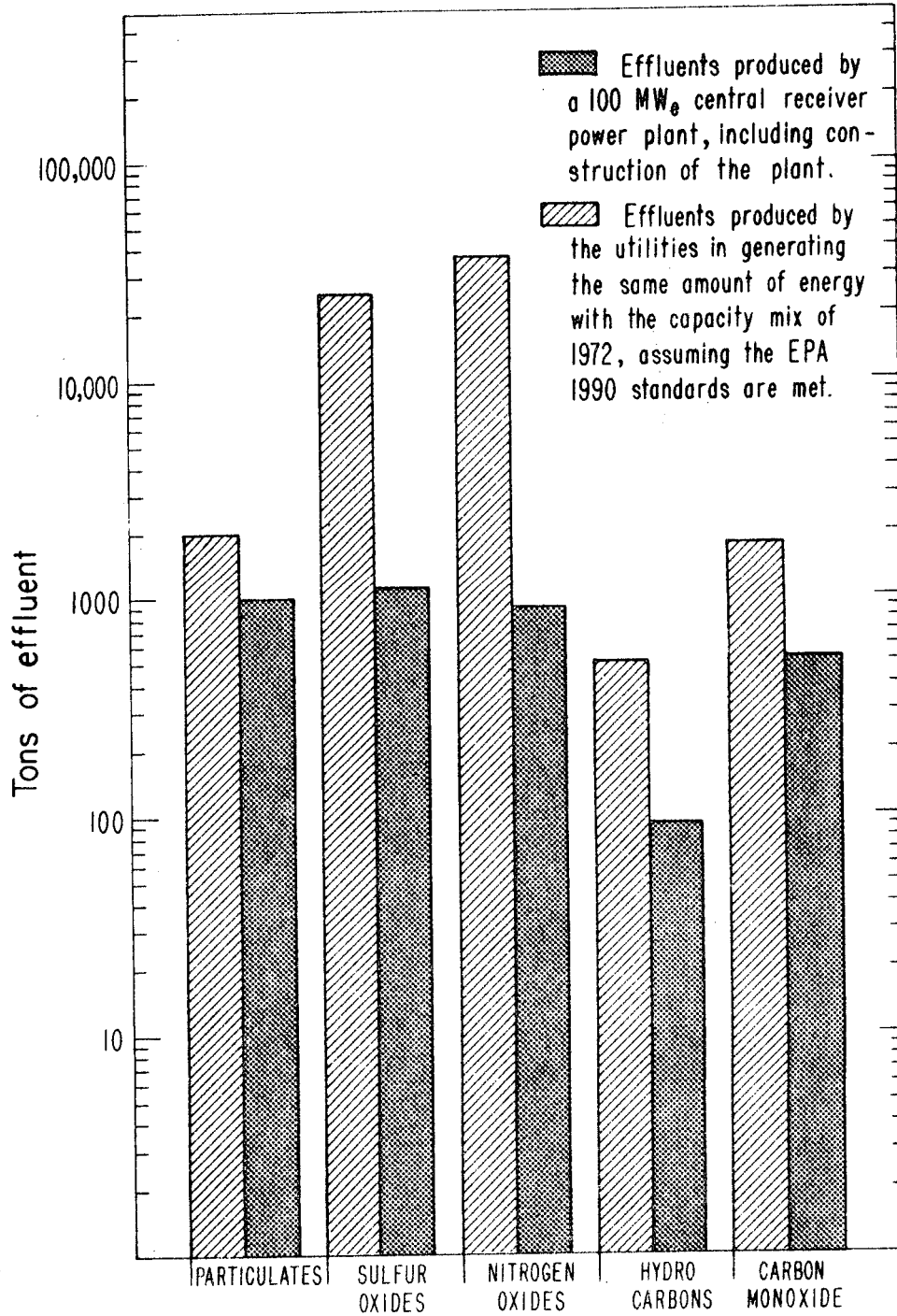

XBL 775-991

Fig. III-3 Effluent Comparison between Central Receiver and Average 1972 Generator.

of the central receiver plant to the utility average calculation for the major air pollutants:  $\text{NO}_x$ ,  $\text{SO}_x$ , particulates, and hydrocarbons. This comparison suggests that the central receiver plants are superior to the utility average for all major air pollutants. It is unlikely that any uncertainties in our cost estimates, bill of goods, or modeling techniques could have caused this result, so that we view it as significant and not explainable by any flaw in our approach. An examination of Table III and IV shows that the CR plant may be worse than the 1972 generator stock for certain types of water pollutants. This is not surprising considering the more intensive industrial activity involved in building a CR plant. However, we do not have confidence in these results on water pollution because the construction of the 1972 generator stock is treated incorrectly by our model.

For the sake of further comparisons between fossil and CR plants, Table V lists estimates of emissions of major air pollutants for different types of fossil fuel plants generating  $1.0 \times 10^7$  MWh along with the corresponding data for CR plants. The estimates for fossil fuel plants are based on the work of Case et al. (1977), which presents emission rates for different types of fossil fuel plants for controlled and uncontrolled cases. Qualitatively, the estimates for the controlled cases suggest the following conclusions. The central receiver would have at least a factor of 10 less  $\text{NO}_x$  than the fossil cases. It would produce about the same amount or slightly more CO. The CR plant would produce about a factor of 10 less  $\text{SO}_x$  than coal or oil, but somewhat more than natural gas. The solar plant would produce substantially less hydrocarbons than coal or oil, but more than natural gas. It would produce somewhat less particulates than coal or residual oil, but would produce more than natural gas. The particulate release associated with CRs comes mainly

Table V. Comparison Between Central Receiver and Various Fossil Fuels for Major Air Emissions.  
 (Units are tons of effluent per lifetime energy output of CR plant.)

Emission type	Plant type				
	coal fired	residual fuel oil	natural gas	oil fired combined cycle	central receiver
Particulates	$1.5 \times 10^3$	$1.9 \times 10^3$	$5.2 \times 10^2$	$1.7 \times 10^3$	$1.0 \times 10^3$
SO <sub>x</sub>	$5.1 \times 10^3$	$1.4 \times 10^4$	$3.1 \times 10^1$	$.9 \times 10^4$	$1.1 \times 10^3$
NO <sub>x</sub>	$3.8 \times 10^4$	$1.5 \times 10^4$	$1.0 \times 10^4$	$1.4 \times 10^4$	$9. \times 10^2$
CO	$2.7 \times 10^3$	$1.0 \times 10^3$	$8.0 \times 10^2$	$5.1 \times 10^3$	$5.2 \times 10^3$
Hydrocarbons	$8.0 \times 10^2$	$6.8 \times 10^2$	47	$1.9 \times 10^3$	$9.3 \times 10^1$

from the cement industry. Particles released by the cement industry tend to be large compared to particulate release from fossil fuel combustion. Small particles are the major concern because of their respiratory effects and because they appear to be more effective catalytic agents in chemical oxidation reactions. Thus the above comparison of particulate emissions is probably biased in favor of fossil fueled plants.

G. Strains Due to Intensive Construction

If an intensive scenario of construction of CR plants were to occur, then large demand increases on different industries or occupations, or substantial increases in industrial release of certain pollutants might occur. As has been mentioned previously, the construction of 100 GWe by the year 2000 is a reasonable upper bound on implementation this century. If this level of construction were spread out over 10 years, a vigorous construction rate, then the amount coming on line each year would be 10 GWe or 100 standard size (100 MWe) plants. Tables VI, VII, and VIII show the results of our model on industrial output, labor, and effluents for this scenario. The industries which are most affected by this scenario, along with their present increases in output relative to 1972, are:

Primary Iron and Steel Manufacturing	-	11%
Heating, Plumbing, and Structural	-	19%
Stamping, Screw Machine Products	-	41%
Engines and Turbines	-	16%
General Industrial Machinery	-	34%
Electric Industrial Equipment	-	15%
Miscellaneous Electrical Machinery	-	14%

The above increases for Stamping, Screw Machine Productions and General Industrial Equipment are somewhat misleading. For Stamping and Screw



Table VI. Industrial Demand Resulting from Construction of 10 GW<sub>e</sub> of Central Receiver Power Plants.

ALL DOLLAR FIGURES ARE IN MILLIONS

I-O NUMBER	I-O DESCRIPTION	1972 OUTPUT LEVEL	DIRECT INCREASE IN DEMAND (BILL OF GOODS)	DIO/1972	CUMULATIVE INCREASE IN DEMAND	CIO/1972
1	LIVESTOCK AND LIVESTOCK PRODUCTS.	46283.674814			60.27241	.00130
2	OTHER AGRICULTURAL PRODUCTS.	41415.269545			56.89240	.00137
3	FORESTRY AND FISHERY PRODUCTS.	4255.561954			25.37445	.00596
4	AGRICULTURAL FORESTRY, FISHERY SERVICES.	2136.228270			3.92190	.00184
5	IRON AND FERROALLOY ORES MINING	1917.541854			186.36203	.09719
6	NONFERROUS METAL ORES MINING	2943.898028			156.42999	.05314
7	COAL MINING	5571.784337			171.81229	.03084
8	CRUDE PETROLEUM AND NATURAL GAS	19709.608544			158.12839	.00802
9	STONE AND CLAY MINING AND QUARRYING	3151.445184			66.46448	.02109
10	CHEMICAL AND FERTILIZER MINERAL MINING	1055.955838			31.81604	.03013
11	NEW CONSTRUCTION.	122240.300000	100.000000	.00082	100.00000	.00082
12	MAINTENANCE AND REPAIR CONSTRUCTION.	30390.000000			202.80361	.00667
13	ORDINANCE AND ACCESSORIES.	10434.796087			24.74199	.00237
14	FOOD AND KINDRED PRODUCTS	118103.620578			138.78033	.00118
15	TOBACCO MANUFACTURES.	10017.083506			6.42621	.00064
16	BROAD AND NARROW FABRICS.	19921.681074			59.37459	.00298
17	MISCELLANEOUS TEXTILE GOODS, FLOOR COVER	7434.169833			38.91173	.00523
18	APPAREL.	29713.352024			29.70398	.00100
19	MISCELLANEOUS FABRICATED TEXTILE PRODUCT	6130.483935			16.75647	.00273
20	LUMBER AND WOOD PRODUCTS.	23521.278520			181.83970	.00773
21	WOODEN CONTAINERS.	973.464853			18.73166	.01924
22	HOUSEHOLD FURNITURE.	7813.300000			17.17381	.00220
23	OTHER FURNITURE AND FIXTURES.	4073.854753			8.96451	.00220
24	PAPER AND ALLIED PRODUCTS.	24175.580822			259.50932	.01073
25	PAPERBOARD CONTAINERS.	7987.375704			156.43660	.01959
26	PRINTING AND PUBLISHING.	29028.220050			186.84358	.00644
27	CHEMICALS AND SELECTED PRODUCTS.	29071.367150	467.056000	.01607	955.92536	.03288
28	PLASTICS AND SYNTHETIC MATERIALS.	11385.802410			155.13258	.01363
29	DRUGS, CLEANING, TOILET PREPARATIONS.	18854.969184			35.77933	.00190
30	PAINTS AND ALLIED PRODUCTS.	3856.892152			73.79389	.01913
31	PETROLEUM REFINING, RELATED PRODS	33590.761110			224.66294	.00669
32	PAVING MIXTURES AND BLOCKS	752.500000			3.01237	.00400
33	ASPHALT FELTS AND COATINGS	740.277060			6.51300	.00880
34	RUBBER AND MISCELLANEOUS PLASTICS PRODUC	21971.049539	100.920000	.00459	368.88487	.01679
35	LEATHER, TANNING AND INDUSTRIAL.	1263.369616			5.64660	.00447
36	FOOTWEAR AND OTHER LEATHER PRODUCTS.	4880.605552			1.85212	.00038
37	GLASS AND GLASS PRODUCTS.	6310.353223	417.136000	.06610	529.43376	.08390
38	STONE AND CLAY PRODUCTS.	15467.125763	421.680000	.02726	628.10659	.04061
39	PRIMARY IRON AND STEEL MANUFACTURING.	40932.954566	1460.397500	.03568	4596.93791	.11230
40	PRIMARY NONFERROUS METAL MANUFACTURING	31440.511146			1791.60388	.05698
41	METAL CONTAINERS.	5093.611713			51.95213	.01020
42	MEATING, PLUMBING AND STRUCTURAL.	17120.056239	3139.090000	.18336	3313.59797	.19355
43	STAMPING, SCREW MACHINE PRODUCTS.	8829.670213	3466.265600	.39257	3667.33218	.41534
44	OTHER FABRICATED METAL PRODUCTS.	17659.246635	583.213100	.03303	1053.22980	.05964
45	ENGINES AND TURBINES.	6479.042708	677.500000	.13544	1055.08221	.16285
46	FARM MACHINERY AND EQUIPMENT.	6219.033649			53.83289	.00866
47	CONSTRUCTION, MINING AND OILFIELD.	8704.167820			113.39746	.01303
48	MATERIALS HANDLING EQUIPMENT.	3395.757981			23.55597	.00694
49	METALWORKING MACHINERY AND EQUIPMENT.	8764.287170			191.36472	.02183
50	SPECIAL INDUSTRY MACHINERY.	7327.732198			63.28503	.00864
51	GENERAL INDUSTRIAL MACHINERY.	4721.250514	2977.140000	.30625	3266.90345	.33606

Table VI. (continued)

52MACHINE SHOP PRODUCTS.	4469.174737			177.76533	.0397P
53OFFICE, COMPUTING, ACCOUNTING MACHINERY.	9010.307472	103.956900	.01154	137.05695	.01521
54SERVICE INDUSTRY MACHINERY.	9851.059371			130.75380	.01327
55ELECTRIC INDUSTRIAL EQUIPMENT.	12121.872927	1387.325400	.11445	1837.12893	.15156
56HOUSEHOLD APPLIANCES.	7852.095548			38.98878	.00497
57ELECTRIC LIGHTING AND WIRING EQUIPMENT.	6192.935625			90.46881	.01461
58RADIO, TELEVISION, COMMUNICATIONS EQUIPM	24055.009838			196.39148	.00816
59ELECTRONIC COMPONENTS.	10079.486356	403.452700	.04003	615.40297	.06105
60MISCELLANEOUS ELECTRICAL MACHINERY.	5223.497144	635.132700	.12159	745.38319	.14270
61MOTOR VEHICLES AND EQUIPMENT.	77561.778889			348.50930	.00449
62AIRCRAFT AND PARTS.	27389.061892			172.61818	.00630
63OTHER TRANSPORTATION EQUIPMENT.	12853.508291			104.62766	.00814
64SCIENTIFIC AND CONTROL INSTRUMENTS.	8300.785452			50.43360	.00608
65OPTICAL AND PHOTOGRAPHIC EQUIPMENT.	70917.677116	26.912000	.00368	44.20116	.00604
66MISCELLANEOUS MANUFACTURING.	13598.788309			41.85994	.00308
67RAILROADS AND RELATED SERVICES	15842.333777			247.37193	.01561
68LOCAL, SUBURBAN PASS. TRANSIT	5382.900000			13.55480	.00252
69MOTOR FRT TRANS + WAREHOUSING	30207.300000			374.42635	.01240
70WATER TRANSPORTATION	9970.550703			66.86910	.00671
71AIR TRANSPORTATION	13437.132213			114.71320	.00854
72PIPELINE TRANSPORTATION	1489.200000			5.98515	.00402
73TRANSPORTATION SERVICES	1458.400000			11.60232	.00796
74COMMUNICATIONS, EXCEPT RADIO AND TELEVIS	30364.900000			230.17580	.00758
75RADIO AND TELEVISION BROADCASTING.	4411.700000			44.66509	.01012
76ELECTRIC UTILITIES	32542.991730			330.93102	.01017
77GAS UTILITIES	21736.200581			280.83411	.01292
78WATER AND SANITARY SERVICES	6463.900000			35.94873	.00556
79WHOLESALE AND RETAIL TRADE.	253562.000000			1270.62794	.00501
80FINANCE AND INSURANCE.	81643.700581			332.87871	.00408
81REAL ESTATE AND RENTAL.	147665.600000			443.11066	.00300
82HOTELS, PERSONAL AND REPAIR SERVICES.	24314.800000			7.54851	.00031
83BUSINESS SERVICES.	88581.000000			935.95605	.01057
84AUTOMOBILE REPAIRS AND SERVICES.	22569.600000			97.38709	.00431
85AMUSEMENTS.	14789.100000			31.84312	.00215
86MEDICAL, EDUCATIONAL, SERVICE, AND NONPR	98278.000000			42.05200	.00043
87FEDERAL GOVERNMENT ENTERPRISES.	12087.000000			66.69126	.00552
88STATE AND LOCAL GOVERNMENT ENTERPRISES.	11036.900000			52.29474	.00474
89DIRECTLY ALLOCATED IMPORTS	0.000000			71.38895	
90TRANSFERRED IMPORTS	0.000000			1578.37456	
91BUSINESS TRAVEL, ENTERTNMT, GIFTS	13763.420450			217.80840	.01583
92OFFICE SUPPLIES.	3067.000000			15.64563	.00510
93SCRAP, USED AND SECONDHAND GOODS	4063.067991			188.71933	.04645
CONSTRUCTION OF 10 GW CAPACITY OF SOLAR POWER.					

Table VII. Employment Induced by Building 10 GW<sub>e</sub> Capacity of Central Receiver Power Plants  
(in thousands of man years).

JOB DESCRIPTION	NUMBER OF JOBS ARE IN THOUSANDS						
	(1) 1972 NUMBER OF JOBS	(2) JOB INCREASE FROM DIRECT INCREASED DEMAND	(3) (2)/(1)	(4) (2)+(1)	(5) JOB INCREASE FROM CUMULATIVE INCREASED DEMAND	(6) (5)/(1)	(7) (5)+(1)
1 TOTAL, ALL OCCUPATIONS	81701.000	500.937	.00613	82201.937	990.783	.01212	82691.783
2 ENGINEERS, AERO-ASTRONAUTIC	52.000	.033	.00064	52.033	.319	.00614	52.319
3 ENGINEERS, CHEMICAL	50.000	.522	.01043	50.522	1.162	.02325	51.162
4 ENGINEERS, CIVIL	154.000	.410	.00266	154.410	1.151	.00747	155.151
5 ENGINEERS, ELECTRICAL	287.000	4.295	.01497	291.295	7.400	.02579	294.400
6 ENGINEERS, INDUSTRIAL	170.000	3.701	.02177	173.701	5.802	.03413	175.802
7 ENGINEERS, MECHANICAL	191.000	4.246	.02223	195.246	6.446	.03375	197.446
8 ENGINEERS, METALLURGICAL	15.000	.511	.03404	15.511	1.008	.06717	16.008
9 ENGINEERS, MINING	8.000	.008	.00098	8.008	.257	.03209	8.257
10 ENGINEERS, PETROLEUM	10.000	.009	.00086	10.009	.066	.00660	10.066
11 ENGINEERS, SALES	40.000	.876	.02191	40.876	1.346	.03366	41.346
12 ENGINEERS, OTHER	124.000	1.997	.01610	125.997	3.192	.02574	127.192
13 AGRICULTURAL SCIENTISTS	13.000	.004	.00027	13.004	.023	.00181	13.023
14 ATMOSPHERIC, SPACE SCIENTISTS	7.000	.016	.00233	7.016	.042	.00602	7.042
15 BIOLOGICAL SCIENTISTS	36.000	.021	.00059	36.021	.084	.00233	36.084
16 CHEMISTS	119.000	1.124	.00945	120.124	2.674	.02247	121.674
17 GEOLOGISTS	25.000	.014	.00055	25.014	.234	.00936	25.234
18 MARINE SCIENTISTS	4.000	.005	.00130	4.005	.015	.00365	4.015
19 PHYSICISTS AND ASTRONOMERS	22.000	.158	.00719	22.158	.289	.01314	22.289
20 LIFE, PHYSICAL SCIENTISTS NEC	3.000	.017	.00559	3.017	.036	.01194	3.036
21 ACTUARIES	6.000	.002	.00032	6.002	.027	.00454	6.027
22 MATHEMATICIANS	6.000	.012	.00208	6.012	.040	.00666	6.040
23 STATISTICIANS	21.000	.088	.00421	21.088	.205	.00978	21.205
24 AGRI, BIOLG, TECH EXC HEALTH	41.000	.016	.00039	41.016	.087	.00212	41.087
25 CHEMICAL TECHNICIANS	77.000	.582	.00756	77.582	1.466	.01904	78.466
26 DRAFTSMEN	286.000	6.659	.02328	292.659	9.978	.03489	295.978
27 ELECTRICAL, ELECTRONIC TECH	164.000	2.547	.01553	166.547	4.120	.02512	168.120
28 INDUSTRIAL ENGINEERING TECH	14.000	.320	.02285	14.320	.512	.03654	14.512
29 MATHEMATICAL TECHN	2.000	.003	.00155	2.003	.011	.00541	2.011
30 MECHANICAL ENGINEERING TECH	12.000	.219	.01822	12.219	.379	.03162	12.379
31 SURVEYORS	71.000	.025	.00036	71.025	.438	.00617	71.438
32 ENGINEERING, SCIENCE TECH NEC	160.000	1.887	.01179	161.887	3.591	.02245	163.591
33 CHIROPRACTORS	17.000	0.000	0.00000	17.000	.007	.00044	17.007
34 DENTISTS	107.000	.000	.00000	107.000	.049	.00046	107.049
35 DIETITIANS	33.000	.000	.00001	33.000	.016	.00049	33.016
36 OPTOMETRISTS	17.000	.000	.00000	17.000	.046	.00270	17.046
37 PHARMACISTS	126.000	.000	.00000	126.000	.553	.00439	126.553
38 PHYSICIANS, MD OSTEOPATHS	328.000	.022	.00007	328.022	.179	.00054	328.179
39 PODIATRISTS	6.000	0.000	0.00000	6.000	.014	.00238	6.014
40 REGISTERED NURSES	801.000	.325	.00041	801.325	.833	.00104	801.833
41 THERAPISTS	115.000	.000	.00000	115.000	.043	.00037	115.043
42 VETERINARIANS	23.000	.000	.00001	23.000	.038	.00166	23.038
43 OTHER MEDICAL AND HEALTH	0.000	0.000	0.00000	0.000	0.000	0.00000	0.000
44 CLINICAL LAB TECHNOL, TECH	143.000	.007	.00005	143.007	.076	.00053	143.076
45 DENTAL HYGIENISTS	22.000	.000	.00000	22.000	.010	.00046	22.010
46 HEALTH RECORD TECHNOL, TECH	12.000	.001	.00005	12.001	.005	.00042	12.005
47 RADIOLOGIC TECHNOL, TECH	68.000	.003	.00005	68.003	.033	.00045	68.033
48 THERAPY ASSISTANTS	3.000	.000	.00004	3.000	.002	.00054	3.002
49 OTHER HEALTH TECHNOL, TECH	67.000	.011	.00017	67.011	.070	.00104	67.070
50 AIRPLANE PILOTS	64.000	.097	.00151	64.097	.581	.00906	64.581

Table VII. (continued)

51 AIR TRAFFIC CONTROLLERS	27.000	0.000	0.00000	27.000	0.000	0.00000	27.000
52 EMBALMERS	6.000	0.000	0.00000	6.000	.002	.00033	6.002
53 FLIGHT ENGINEERS	4.000	.001	.00023	4.001	.032	.00791	4.032
54 RADIO OPERATORS	37.000	.017	.00047	37.017	.134	.00362	37.134
55 TOOL PROGRAMMERS, NUMERICAL	2.000	.050	.02521	2.050	.078	.03899	2.078
56 OTHER TECHNICIANS EXC HEALTH	12.000	.028	.00237	12.028	.087	.00722	12.087
57 COMPUTER PROGRAMMERS	186.000	1.305	.00702	187.305	2.730	.01468	188.730
58 COMPUTER SYSTEMS ANALYSTS	74.000	.520	.00703	74.520	1.104	.01492	75.104
59 OTHER COMPUTER SPECIALISTS	13.000	.081	.00621	13.081	.178	.01371	13.178
60 ECONOMISTS	68.000	.570	.00838	68.570	1.147	.01687	69.147
61 POLITICAL SCIENTISTS	2.000	.001	.00058	2.001	.003	.00161	2.003
62 PSYCHOLOGISTS	50.000	.004	.00007	50.004	.044	.00097	50.044
63 SOCIOLOGISTS	4.000	.001	.00016	4.001	.007	.00165	4.007
64 URBAN AND REGIONAL PLANNERS	12.000	.000	.00001	12.000	.024	.00203	12.024
65 OTHER SOCIAL SCIENTISTS	6.000	.000	.00000	6.000	.003	.00045	6.003
66 ADULT EDUCATION TEACHERS	69.000	.168	.00244	69.168	.297	.00431	69.297
67 AGRICULTURE TEACHERS	8.000	0.000	0.00000	8.000	.001	.00014	8.001
68 ART, DRAMA, MUSIC TEACHERS	30.000	0.000	0.00000	30.000	.004	.00014	30.004
69 ATMOSPHERIC, EARTH, MARINE	7.000	0.000	0.00000	7.000	.001	.00014	7.001
70 BIOLOGY TEACHERS	23.000	0.000	0.00000	23.000	.003	.00014	23.003
71 BUSINESS, COMMERCE TEACHERS	12.000	0.000	0.00000	12.000	.002	.00014	12.002
72 CHEMISTRY TEACHERS	17.000	0.000	0.00000	17.000	.002	.00014	17.002
73 COACHES, PHYS ED TEACHERS	12.000	0.000	0.00000	12.000	.002	.00014	12.002
74 ECONOMIC TEACHERS	12.000	0.000	0.00000	12.000	.002	.00014	12.002
75 EDUCATION TEACHERS	15.000	0.000	0.00000	15.000	.002	.00014	15.002
76 ELEMENTARY SCHOOL TEACHERS	1251.000	0.000	0.00000	1251.000	.050	.00004	1251.050
77 ENGINEERING TEACHERS	22.000	0.000	0.00000	22.000	.003	.00014	22.003
78 ENGLISH TEACHERS	34.000	0.000	0.00000	34.000	.005	.00014	34.005
79 FOREIGN LANGUAGE TEACHERS	22.000	0.000	0.00000	22.000	.003	.00014	22.003
80 HEALTH SPECIALTIES TEACHERS	41.000	0.000	0.00000	41.000	.006	.00014	41.006
81 HISTORY TEACHERS	21.000	0.000	0.00000	21.000	.003	.00014	21.003
82 HOME ECONOMICS TEACHERS	5.000	0.000	0.00000	5.000	.001	.00014	5.001
83 LAW TEACHERS	3.000	0.000	0.00000	3.000	.000	.00014	3.000
84 MATHEMATICS TEACHERS	39.000	0.000	0.00000	39.000	.006	.00014	39.006
85 PHYSICS TEACHERS	15.000	0.000	0.00000	15.000	.002	.00014	15.002
86 PRESCHOOL, KINDERGARTEN	188.000	.000	.00000	188.000	.014	.00007	188.014
87 PSYCHOLOGY TEACHERS	23.000	0.000	0.00000	23.000	.003	.00014	23.003
88 SECONDARY SCHOOL TEACHERS	1114.000	0.000	0.00000	1114.000	.044	.00004	1114.044
89 SOCIOLOGY TEACHERS	11.000	0.000	0.00000	11.000	.002	.00014	11.002
90 SOCIAL SCIENCE TEACHERS NEC	15.000	0.000	0.00000	15.000	.002	.00014	15.002
91 MISC COLLEGE AND UNIVERSITY	27.000	0.000	0.00000	27.000	.004	.00014	27.004
92 COLLEGE, UNIVERSITY NEC	37.000	0.000	0.00000	37.000	.005	.00014	37.005
93 THEOLOGY TEACHERS	5.000	0.000	0.00000	5.000	.001	.00014	5.001
94 TRADE, INDUSTRIAL TEACHERS	4.000	0.000	0.00000	4.000	.001	.00014	4.001
95 TEACHERS NEC, EXC COLL, UNIVER	220.000	.091	.00041	220.091	.354	.00161	220.354
96 ACTORS	10.000	0.000	0.00000	10.000	.027	.00271	10.027
97 ATHLETES AND KINDRED WORKERS	78.000	.000	.00000	78.000	.147	.00189	78.147
98 AUTHORS	30.000	.097	.00322	30.097	.263	.00877	30.263
99 DANCERS	5.000	.000	.00007	5.000	.019	.00371	5.019
100 DESIGNERS	110.000	1.030	.00936	111.030	1.924	.01749	111.924
101 EDITORS AND REPORTERS	163.000	.137	.00084	163.137	1.148	.00704	164.148
102 MUSICIANS AND COMPOSERS	121.000	.000	.00000	121.000	.244	.00203	121.244
103 PAINTERS AND SCULPTORS	129.000	.156	.00121	129.156	.880	.00682	129.880
104 PHOTOGRAPHERS	77.000	.131	.00171	77.131	.405	.00526	77.405
105 PUBLIC RELATIONS MEN, WRITERS	87.000	.231	.00266	87.231	.731	.00840	87.731
106 RADIO, TV ANNOUNCERS	22.000	.000	.00001	22.000	.216	.00983	22.216
107 WRITERS, ARTISTS, ENTERTAIN NEC	66.000	.237	.00359	66.237	.545	.00887	66.545
108 ACCOUNTANTS	714.000	4.343	.00668	718.343	10.015	.01403	724.015
109 ARCHITECTS	66.000	.029	.00044	66.029	.608	.00918	66.608
110 ARCHIVISTS AND CURATORS	7.000	.000	.00000	7.000	.010	.00147	7.010
111 CLERGYMEN	245.000	0.000	0.00000	245.000	.107	.00044	245.107
112 RELIGIOUS, EXC CLERGYMEN	47.000	0.000	0.00000	47.000	.024	.00061	47.024

Table VII. (continued)

113 FARM MANAGEMENT ADVISORS	13.000	0.000	0.00000	13.000	.007	.00054	13.007
114 FORESTERS, CONSERVATIONISTS	48.000	.001	.00002	48.001	.195	.00407	48.195
115 HOME MANAGEMENT ADVISORS	8.000	.000	.00005	8.000	.025	.00317	8.025
116 JUDGES	16.000	0.000	0.00000	16.000	0.000	0.00000	16.000
117 LAWYERS	303.000	.133	.00044	303.133	2.822	.00931	305.822
118 LIBRARIANS	151.000	.051	.00034	151.051	.160	.00106	151.160
119 OPERATIONS, SYSTEMS RESEARCH	111.000	1.748	.01575	112.748	2.940	.02649	113.940
120 PERSONNEL LABOR RELATIONS	310.000	1.782	.00575	311.782	4.126	.01331	314.126
121 RESEARCH WORKERS, NEC	86.000	.231	.00268	86.231	.579	.00674	86.579
122 RECREATION WORKERS	92.000	.001	.00001	92.001	.078	.00084	92.078
123 SOCIAL WORKERS	263.000	.000	.00000	263.000	.105	.00040	263.105
124 VOCATIONAL, ED COUNSELORS	134.000	.004	.00003	134.004	.043	.00032	134.043
125 BANK, FINANCIAL MANAGERS	427.000	.631	.00148	427.631	2.618	.00613	429.618
126 CREDITMEN	71.000	.301	.00424	71.301	.745	.01549	71.745
127 BUYERS, SHIPPERS, FARM PROD	22.000	0.000	0.00000	22.000	.096	.00438	22.096
128 BUYERS, WHOLESALE, RETAIL	161.000	0.000	0.00000	161.000	.807	.00501	161.807
129 PURCHASING AGENTS, BUYERS, NEC	181.000	3.438	.01899	184.438	5.096	.02815	186.096
130 SALES MANAGER, RETAIL TRADE	296.000	0.000	0.00000	296.000	1.483	.00501	297.483
131 SALES MANAGER, EXC RET TRADE	274.000	2.721	.00993	276.721	4.947	.01806	278.947
132 ASSESS, CONTROL, LOC PUB ADMIN	29.000	0.000	0.00000	29.000	0.000	0.00000	29.000
133 CONSTRUCTION INSPECTOR, PUB	23.000	0.000	0.00000	23.000	0.000	0.00000	23.000
134 HEALTH ADMINISTRATORS	118.000	0.000	0.00000	118.000	.047	.00040	118.047
135 INSPECTORS, EXC CONSTRUCT PUB	97.000	0.000	0.00000	97.000	.008	.00009	97.008
136 OFFICIALS, ADMINS, PUB	309.000	.001	.00000	309.001	.043	.00014	309.043
137 POSTMASTERS AND MAIL SUPER	44.000	0.000	0.00000	44.000	.243	.00552	44.243
138 SCHOOL ADMIN, COLLEGE	83.000	0.000	0.00000	83.000	.012	.00014	83.012
139 SCHOOL ADMIN, ELEM, SECONDARY	221.000	0.000	0.00000	221.000	.009	.00004	221.009
140 FUNERAL DIRECTORS	40.000	0.000	0.00000	40.000	.014	.00034	40.014
141 MGRS, SUPERINTENDENTS, BLDG	136.000	.009	.00007	136.009	.409	.00301	136.409
142 OFFICE MANAGERS, NEC	315.000	1.628	.00517	316.628	3.597	.01142	318.597
143 OFFICERS, PILOTS, PURSERS, SHIP	30.000	.008	.00027	30.008	.191	.00636	30.191
144 OFFICIALS OF LODGES, UNIONS	80.000	0.000	0.00000	80.000	.034	.00043	80.034
145 RAILROAD CONDUCTORS	45.000	0.000	0.00000	45.000	.703	.01561	45.703
146 RESTAURANT, CAFE, BAR MGRS	494.000	.044	.00009	494.044	2.316	.00469	496.316
147 OTHER MGRS, ADMINISTRATORS	4531.000	23.901	.00527	4554.901	52.176	.01152	4583.176
148 ADVERTISING AGENTS, SALESMEN	66.000	.050	.00076	66.050	.622	.00942	66.622
149 AUCTIONEERS	3.000	.000	.00005	3.000	.024	.00787	3.024
150 DEMONSTRATORS	64.000	.037	.00058	64.037	.366	.00572	64.366
151 HUCKSTERS AND PEDDLERS	230.000	0.000	0.00000	230.000	1.178	.00512	231.178
152 INSURANCE AGENTS, BROKERS, ETC	441.000	0.000	0.00000	441.000	1.791	.00406	442.791
153 NEWSBOYS	90.000	0.000	0.00000	90.000	.548	.00609	90.548
154 REAL ESTATE AGENTS, BROKERS	349.000	0.000	0.00000	349.000	1.047	.00300	350.047
155 STOCK AND BOND SALESMEN	101.000	0.000	0.00000	101.000	.411	.00407	101.411
156 SALES REPRES, MFG	400.000	7.537	.01884	407.537	11.589	.02897	411.589
157 SALES REPRES, WHOLESALE TRADE	696.000	.001	.00000	696.001	3.493	.00502	699.493
158 SALES CLERKS, RETAIL TRADE	2348.000	0.000	0.00000	2348.000	11.764	.00501	2359.764
159 SALESMEN, RETAIL TRADE	430.000	0.000	0.00000	430.000	2.155	.00501	432.155
160 SALESMEN, SERV AND CONST	136.000	.010	.00007	136.010	.775	.00569	136.775
161 SECRETARIES, LEGAL	109.000	.044	.00041	109.044	1.071	.00983	110.071
162 SECRETARIES, MEDICAL	84.000	.006	.00007	84.006	.062	.00073	84.062
163 SECRETARIES, OTHER	2756.000	14.182	.00515	2770.182	29.290	.01063	2785.290
164 STENOGRAPHERS	125.000	.460	.00368	125.460	1.105	.00884	126.105
165 TYPISTS	1021.000	4.190	.00410	1025.190	9.539	.00934	1030.539
166 BOOKKEEPING, BILLING OPERATORS	69.000	.263	.00381	69.263	.649	.00941	69.649
167 CALCULATING MACHINE OPERATORS	36.000	.140	.00389	36.140	.377	.01046	36.377
168 COMPUTER, PERIPHERAL EQUIP	196.000	1.318	.00672	197.318	2.752	.01404	198.752
169 DUPLICATING MACHINE OPERATORS	21.000	.144	.00684	21.144	.298	.01417	21.298
170 KEYPUNCH OPERATORS	283.000	1.868	.00660	284.868	4.040	.01428	287.040
171 TABULATING MACHINE OPERATORS	10.000	.087	.00874	10.087	.157	.01572	10.157
172 OTHER OFFICE MACHINE OPERATORS	59.000	.201	.00340	59.201	.556	.00943	59.556
173 BANK TELLERS	288.000	0.000	0.00000	288.000	1.176	.00408	289.176
174 BILLING CLERKS	149.000	1.083	.00727	150.083	2.260	.01520	151.280

Table VII. (continued)

175 BOOKKEEPERS	1584.000	6.385	.00403	1590.385	15.587	.00984	1599.587
176 CASHIERS	998.000	.124	.00012	998.124	4.742	.00475	1002.742
177 CLERICAL ASSIST, SOC WELFARE	4.000	0.000	0.00000	4.000	.002	.00044	4.002
178 CLERICAL SUPERVISORS, NEC	199.000	.616	.00309	199.616	1.641	.00824	200.641
179 COLLECTORS, BILL AND ACCOUNT	60.000	.023	.00038	60.023	.382	.00637	60.382
180 COUNTER CLERKS, EXC FOOD	329.000	1.011	.00307	330.011	2.346	.00713	331.346
181 DISPATCHER, STARTER, VEHICLE	86.000	.193	.00225	86.193	.888	.01033	86.888
182 ENUMERATORS AND INTERVIEWERS	39.000	.006	.00016	39.006	.112	.00288	39.112
183 ESTIMATORS, INVESTIGATORS, NEC	348.000	1.884	.00541	349.884	3.949	.01135	351.949
184 EXPEDITORS, PROD CONTROLLERS	195.000	4.580	.02349	199.580	7.254	.03720	202.254
185 FILE CLERKS	272.000	1.138	.00418	273.138	2.649	.00974	274.649
186 INSURANCE ADJUST, EXAM	108.000	.002	.00002	108.002	.453	.00420	108.453
187 LIBRARY ATTENDANTS, ASSISTANT	137.000	.027	.00020	137.027	.112	.00081	137.112
188 MAIL CARRIERS, POST OFFICE	270.000	0.000	0.00000	270.000	1.490	.00552	271.490
189 MAIL HANDLER, EXC POST OFFICE	128.000	.429	.00336	128.429	1.211	.00946	129.211
190 MESSENGERS AND OFFICE BOYS	78.000	.103	.00133	78.103	.557	.00715	78.557
191 METER READERS, UTILITIES	33.000	0.000	0.00000	33.000	.287	.00870	33.287
192 PAYROLL, TIME KEEPING CLERKS	184.000	2.362	.01284	186.362	4.072	.02213	188.072
193 POSTAL CLERKS	281.000	0.000	0.00000	281.000	1.550	.00552	282.550
194 PROOFREADERS	28.000	0.000	0.00000	28.000	.180	.00644	28.180
195 REAL ESTATE APPRAISERS	22.000	.001	.00003	22.001	.062	.00280	22.062
196 RECEPTIONISTS	436.000	1.094	.00251	437.094	2.469	.00566	438.469
197 SHIPPING, RECEIVING CLERKS	451.000	6.559	.01454	457.559	10.943	.02426	461.943
198 STATISTICAL CLERKS	299.000	1.438	.00481	300.438	3.470	.01161	302.470
199 STOCK CLERKS, STORE KEEPERS	511.000	5.611	.01098	516.611	9.687	.01896	520.687
200 TEACHERS AIDES, EXC MONITORS	206.000	0.000	0.00000	206.000	.012	.00006	206.012
201 TELEGRAPH MESSENGERS	1.000	0.000	0.00000	1.000	.008	.00758	1.008
202 TELEGRAPH OPERATORS	9.000	.000	.00000	9.000	.109	.01217	9.109
203 TELEPHONE OPERATORS	392.000	.617	.00157	392.617	3.191	.00814	395.191
204 TICKET STATION, EXPRESS AGENTS	128.000	.000	.00000	128.000	1.152	.00900	129.152
205 WEIGHERS	43.000	.452	.01051	43.452	1.021	.02375	44.021
206 MISC CLERICAL WORKERS, NEC	1182.000	3.334	.00282	1185.334	8.357	.00707	1190.357
207 CARPENTERS	1027.000	2.176	.00212	1029.176	5.803	.00565	1032.803
208 CARPENTERS APPRENTICES	18.000	.028	.00153	18.028	.092	.00511	18.092
209 BRICKMASON AND STONEMASONS	170.000	.706	.00415	170.706	1.745	.01026	171.745
210 BRICK, STONEMASON APPREN	6.000	.022	.00360	6.022	.052	.00867	6.052
211 BULLDOZER OPERATORS	140.000	.503	.00360	140.503	1.715	.01225	141.715
212 CEMENT AND CONCRETE FINISHERS	79.000	.125	.00159	79.125	.315	.00398	79.315
213 ELECTRICIANS	469.000	4.187	.00893	473.187	8.523	.01817	477.523
214 ELECTRICIANS APPREN	25.000	.163	.00652	25.163	.386	.01545	25.386
215 EXCAVATING, GRADING, MACH OP	286.000	.407	.00142	286.407	1.558	.00545	287.558
216 FLOOR LAYERS, EXC TILE SETTERS	19.000	.023	.00118	19.023	.088	.00462	19.088
217 PAINTERS, CONSTRUCTION, MAINT	426.000	1.646	.00386	427.646	3.095	.00727	429.695
218 PAINTER APPREN	2.000	.004	.00181	2.004	.011	.00551	2.011
219 PAPERHANGERS	15.000	.009	.00057	15.009	.040	.00265	15.040
220 PLASTERERS	28.000	.020	.00070	28.020	.073	.00262	28.073
221 PLASTERER APPREN	0.000	0.000	0.00000	0.000	0.000	0.00000	0.000
222 PLUMBERS AND PIPEFITTERS	370.000	1.834	.00496	371.834	4.099	.01108	374.099
223 PLUMBERS, PIPEFITTERS APPREN	19.000	.080	.00420	19.080	.171	.00900	19.171
224 ROOFERS AND SLATERS	85.000	.072	.00085	85.072	.239	.00281	85.239
225 STRUCTURAL METAL CRAFT	74.000	2.817	.03807	76.817	3.316	.04481	77.316
226 TILESETTERS	35.000	.039	.00112	35.039	.135	.00385	35.135
227 FOREMEN, NEC	1413.000	20.999	.01486	1433.999	36.727	.02599	1449.727
228 BLACKSMITHS	10.000	.097	.00969	10.097	.269	.02689	10.269
229 BOILERMAKERS	37.000	1.794	.04848	38.794	2.321	.06274	39.321
230 HEAT TREATERS, ANNEALERS, ETC	23.000	1.235	.05368	24.235	2.081	.09046	25.081
231 FORGEMEN AND HAMMERMEN	12.000	1.203	.10026	13.203	1.609	.13411	13.609
232 JOB AND DIE SETTERS, METAL	94.000	8.745	.69303	102.745	10.655	.11336	104.655
233 MACHINISTS	367.000	15.239	.04152	382.239	21.572	.05878	388.572
234 MACHINIST APPREN	10.000	.462	.04617	10.462	.674	.06741	10.674
235 MILLWRIGHTS	86.000	2.189	.02545	88.189	4.397	.05113	90.397
236 MILLWRIGHTS, METAL	52.000	2.085	.04011	54.085	4.491	.06676	56.491

Table VII. (continued)

237	MOLDERS APPREN	1.000		.026	.02561	1.026	.072	.07229	1.072
238	PATTERN AND MODEL MAKERS	43.000	1.233	.02867	44.233	1.931	.04491	44.931	
239	ROLLERS AND FINISHERS, METAL	17.000	.981	.05770	17.981	1.956	.11507	18.956	
240	SHEET METAL WORKERS, TINSMITHS	144.000	5.911	.04105	149.911	7.072	.04911	151.072	
241	SHEET METAL APPREN	5.000	.227	.04534	5.227	.261	.05217	5.261	
242	TOOL, DIE MAKERS	172.000	9.992	.05809	181.992	13.225	.07689	185.225	
243	TOOL, DIE MAKER APPREN	12.000	.725	.06044	12.725	.959	.07986	12.959	
244	AIR COND, HEATING, REFRIG	174.000	.812	.00467	174.812	1.674	.00962	175.674	
245	AIRCRAFT	123.000	.094	.00076	123.094	.853	.00694	123.853	
246	AUTO ACCESSORIES INSTALR	10.000	.013	.00135	10.013	.063	.00625	10.063	
247	AUTO BODY REPAIRMEN	161.000	.044	.00027	161.044	.801	.00498	161.801	
248	AUTO MECHANICS	867.000	1.046	.00121	868.046	5.817	.00671	872.817	
249	AUTO MECHANICS APPREN	5.000	.002	.00041	5.002	.030	.00602	5.030	
250	DATA PROCESSING MACH REPAIRMEN	45.000	.202	.00451	45.202	.521	.01150	45.521	
251	FARM IMPLEMENTS	47.000	.058	.00123	47.058	.327	.00697	47.327	
252	HEAVY EQUIP MECH, INCL DIESEL	714.000	12.229	.01713	726.229	20.932	.02932	734.932	
253	HOUSEHOLD APPLIANCE MECHANICS	132.000	.284	.00215	132.284	1.126	.00853	133.126	
254	LOOM FIXERS	18.000	.016	.00090	18.016	.077	.00425	18.077	
255	OFFICE MACHINE REPAIRMEN	69.000	.137	.00198	69.137	.522	.00757	69.522	
256	RADIO, TELEVISION REPAIRMEN	124.000	.185	.00149	124.185	.763	.00615	124.763	
257	RAILROAD, CAR SHOP REPAIRMEN	55.000	.069	.00126	55.069	.978	.01778	55.978	
258	MECHANICS EXC AUTO APPREN	10.000	.165	.01652	10.165	.329	.03290	10.329	
259	OTHER MECHANICS AND REPAIRMEN	223.000	1.359	.00610	224.359	3.132	.01404	226.132	
260	BOOKBINDERS	32.000	.001	.00002	32.001	.202	.00630	32.202	
261	COMPOSITORS AND TYPESETTERS	170.000	.337	.00198	170.337	1.510	.00888	171.510	
262	ELECTROTYPERS, STEREOTYPERS	4.000	.009	.00228	4.009	.042	.01054	4.042	
263	ENGRAVERS EXC PHOTOENGRAVERS	12.000	.209	.01742	12.209	.323	.02694	12.323	
264	PHOTOENGRAVERS, LITHOGRAPHERS	39.000	.118	.00302	39.118	.391	.01002	39.391	
265	PRESSMEN AND PLATE PRINTERS	142.000	.416	.00293	142.416	1.485	.01046	143.485	
266	PRESSMEN APPREN	3.000	.017	.00572	3.017	.040	.01344	3.040	
267	PRINTING APPREN, EXC PRESS	7.000	.013	.00184	7.013	.059	.00840	7.059	
268	ELECTRIC POWR LINEMEN, CABLEMEN	102.000	.032	.00031	102.032	.878	.00861	102.878	
269	LOCOMOTIVE ENGINEERS	53.000	.118	.00224	53.118	1.113	.02100	54.113	
270	LOCOMOTIVE FIREMEN	15.000	.007	.00044	15.007	.252	.01682	15.252	
271	POWER STATION OPERATORS	22.000	.109	.00496	22.109	.379	.01722	22.379	
272	TELEPHONE INSTALLRS, REPAIRMEN	310.000	.049	.00016	310.049	2.389	.00771	312.389	
273	TELEPHONE LINEMEN, SPLICERS	67.000	.003	.00005	67.003	.508	.00759	67.508	
274	BAKERS	114.000	.019	.00016	114.019	.350	.00307	114.350	
275	CABINETMAKERS	60.000	.095	.00158	60.095	.356	.00593	60.356	
276	CARPET INSTALLERS	62.000	.020	.00032	62.020	.238	.00384	62.238	
277	CRANEMEN, DERRICKMEN, HOISTMEN	150.000	4.231	.02821	154.231	8.656	.05770	158.656	
278	DECORATORS, WINDOW DRESSERS	87.000	.005	.00006	87.005	.486	.00558	87.486	
279	DENTAL LABORATORY TECH	33.000	.003	.00010	33.003	.040	.00120	33.040	
280	FURNITURE AND WOOD FINISH	27.000	.006	.00022	27.006	.125	.00461	27.125	
281	FURRIERS	3.000	.002	.00071	3.002	.014	.00457	3.014	
282	GLAZIERS	27.000	.194	.00719	27.194	.334	.01236	27.334	
283	INSPECTORS, LOG AND LUMBER	23.000	.001	.00002	23.001	.175	.00761	23.175	
284	INSPECTORS, OTHER	131.000	.808	.00617	131.808	2.590	.01977	133.590	
285	JEWELERS AND WATCHMAKERS	39.000	.007	.00018	39.007	.218	.00558	39.218	
286	MILLERS, GRAIN, FLOUR, FEED	4.000	.001	.00014	4.001	.057	.00170	4.007	
287	MOTION PICTURE PROJECTIONISTS	12.000	.001	.00008	12.001	.628	.00232	12.028	
288	OPTICIANS, LENS GRINDR, POLISHR	30.000	.070	.00235	30.070	.724	.00747	30.724	
289	PIANO, ORGAN TUNERS, REPAIRMEN	6.000	0.000	0.00000	6.000	.641	.00695	6.041	
290	SHIPFITTERS	11.000	.024	.00215	11.024	.115	.01042	11.115	
291	SHOE REPAIRMEN	22.000	.003	.00012	22.003	.521	.00694	22.021	
292	SIGN PAINTERS AND LETTERS	21.000	.024	.00114	21.024	.260	.00951	21.260	
293	STATIONARY ENGINEERS	190.000	.903	.00475	190.903	2.474	.01702	192.474	
294	STONE CUTTERS, STONE CARVERS	6.000	.111	.01857	6.111	.184	.00658	6.184	
295	TAILORS	62.000	.002	.00003	62.002	.158	.00222	62.158	
296	UPHOLSTERERS	66.000	.017	.00026	66.017	.511	.00502	66.331	
297	CRAFTSMEN, KINDRED WORKRS, NEF	68.500	.673	.00982	69.173	1.299	.01847	69.799	
298	FORMER ARMED FORCES MEMBERS	300	0.000	0.00000	300	0.000	0.00000	300	

Table VII. (continued)

299 CRAFT APPREN, NEC	9.200	.093	.01006	9.293	.175	.01904	9.375
300 DRILL PRESS OPERATIVES	75.000	4.285	.05713	79.285	5.657	.07543	80.657
301 FURNACEMEN, SMELTERMEN, POURERS	70.000	2.712	.03875	72.712	6.426	.09180	76.426
302 GRINDING MACHINE OPERATIVES	130.000	6.237	.04798	136.237	9.542	.07340	139.542
303 HEATERS, METAL	3.000	.126	.04187	3.126	.308	.10261	3.308
304 LATHE, MILLING MACH OPERATIVES	123.000	6.260	.05089	129.260	8.699	.07073	131.699
305 METAL PLATERS	37.000	1.997	.05397	38.997	2.684	.07253	39.684
306 OTHER PRECISION MACH OPR	61.000	5.205	.08534	66.205	6.374	.10449	67.374
307 PUNCH STAMPING PRESS OPR	157.000	16.012	.10199	173.012	19.019	.12114	176.019
308 SOLDERERS	43.000	1.301	.03026	44.301	1.908	.04438	44.908
309 WELDERS AND FLAME CUTTERS	554.000	25.013	.04515	579.013	33.503	.06047	587.503
310 CARDING, LAPPING, COMBING	26.000	.000	.00001	26.000	.093	.00357	26.093
311 KNITTERS, LOOPERS, AND TOPPERS	41.000	0.000	0.00000	41.000	.055	.00135	41.055
312 SPINNERS, TWISTERS, WINDERS	168.000	.001	.00000	168.001	.716	.00426	168.716
313 WEAVERS	47.000	0.000	0.00000	47.000	.154	.00327	47.154
314 OTHER TEXTILE OPERATIVES	142.000	.001	.00001	142.001	.472	.00332	142.472
315 CHECKERS, EXAMINERS, ETC, MFG	685.000	20.448	.02985	705.448	29.769	.04246	714.769
316 GRADERS AND SORTERS, MFG	44.000	.487	.01107	44.487	.800	.01818	44.800
317 MEAT WRAPPERS, RETAIL TRADE	50.000	0.000	0.00000	50.000	.251	.00501	50.251
318 PACKER, WRAPPER, EX MEAT, PRODUCE	647.000	6.563	.01014	653.563	11.197	.01731	658.197
319 PROD GRDR, PACKER, EXC FACT, FARM	35.000	0.000	0.00000	35.000	.178	.00529	35.178
320 ASBESTOS, INSULATION WORKERS	30.000	.090	.00300	30.090	.223	.00742	30.223
321 ASSEMBLERS	1017.000	31.875	.03134	1048.875	44.677	.04393	1061.677
322 BLASTERS AND POWDERMEN	8.000	.019	.00236	8.019	.183	.02284	8.183
323 BOTTLING, CANNING OPERATIVES	55.000	.012	.00022	55.012	.121	.00221	55.121
324 CHAINMEN, RODMEN, AXMEN SURVEYNG	17.000	.005	.00029	17.005	.119	.00698	17.119
325 CLOTHING IRONERS AND PRESSERS	164.000	.010	.00006	164.010	.120	.00073	164.120
326 CUTTING OPERATIVES, NEC	238.000	5.192	.02182	243.192	8.250	.03466	246.250
327 DRESSMAKER, SEAMSTRESS, EXC FACT	132.000	0.000	0.00000	132.000	.398	.00301	132.398
328 DRILLERS, EARTH	50.000	.528	.01056	50.528	1.186	.02372	51.186
329 DRY WALL INSTALLERS, LATHES	83.000	.049	.00059	83.049	.208	.00250	83.208
330 DYERS	29.000	.030	.00103	29.030	.140	.00484	29.140
331 FILER, POLISHER, SANDER, BUFFER	122.000	4.062	.03330	126.062	5.737	.04703	127.737
332 GARAGE WORKERS, GAS STAT ATTEN	502.000	.026	.00005	502.026	2.570	.00512	504.570
333 LAUNDRY, DRY CLEAN OP, NEC	165.000	.005	.00003	165.005	.080	.00048	165.080
334 MEAT CUTTERS, BUTCHERS, EXC MFG	201.000	0.000	0.00000	201.000	.999	.00497	201.999
335 MEAT CUTTERS, BUTCHERS	89.000	.010	.00011	89.010	.120	.00134	89.120
336 MILLINERS	0.000	0.000	0.00000	0.000	0.000	0.00000	0.000
337 MINE OPERATIVES, NEC	142.000	.016	.00011	142.016	3.536	.02490	145.536
338 MIXING OPERATIVES	99.000	1.159	.01171	100.159	2.295	.02318	101.295
339 OILERS, GREASERS, EXC AUTO	46.000	.566	.01231	46.566	1.253	.02723	47.253
340 PAINTERS, MFG ARTICLES	178.000	5.155	.02896	183.155	7.220	.04056	185.220
341 PHOTOGRAPHIC PROCESS WORKERS	81.000	.417	.00515	81.417	1.000	.01235	82.000
342 RIVETERS AND FASTENERS	34.000	.880	.02589	34.880	1.261	.03709	35.261
343 SAILORS AND DECKHANDS	21.000	.005	.00024	21.005	.140	.00666	21.140
344 SAWYERS	121.000	.955	.00789	121.955	2.125	.01756	123.125
345 SEWERS AND STITCHERS	936.000	.280	.00030	936.280	1.692	.00181	937.692
346 SHOEMAKING MACHINE OPR	76.000	.009	.00017	76.009	.063	.00083	76.063
347 STATIONARY FIREMEN	81.000	.723	.00893	81.723	1.536	.01896	82.536
348 WINDING OPERATIVES, NEC	73.000	2.714	.03718	75.714	4.183	.05730	77.183
349 MISC MACH OPERATIVES	1306.600	25.313	.01937	1331.913	43.772	.03350	1350.372
350 OPERATIVES, NEC	1107.400	17.249	.01558	1124.649	30.535	.02757	1127.935
351 BOATMEN AND CANALMEN	6.000	.003	.00055	6.003	.039	.00656	6.039
352 BUS DRIVERS	252.000	.007	.00003	252.007	.755	.00299	252.755
353 CONDUCTORS, MOTORMEN, URBAN RAIL	14.000	.000	.00001	14.000	.047	.00337	14.047
354 DELIVERY AND ROUTEMEN	892.000	1.429	.00160	893.429	5.986	.00671	897.986
355 FORK LIFT, TOW MOTOR OPR	303.000	6.508	.02147	309.508	10.489	.02462	313.489
356 MOTORMEN, MINE, FACT, LOGGING	11.000	.084	.00778	11.084	.492	.04469	11.492
357 PARKING ATTENDANTS	33.000	.002	.00005	33.002	.131	.00497	33.131
358 RAILROAD BRAKEMEN	45.000	.087	.00194	45.087	.882	.01943	45.882
359 RAILROAD SWITCHMEN	47.000	.141	.00300	47.141	1.035	.02303	48.035
360 TAXICAB DRIVERS, CHAUFFEURS	166.000	.111	.00067	166.111	.567	.00564	166.567



Table VII. (continued)

361 TRUCK DRIVERS	1441.000	4.834	.00335	1445.834	18.449	.01280	1459.449
362 CHAMBERMAID, MAID, EXC PRIV	187.000	.003	.00001	187.003	.134	.00072	187.134
363 CLEANERS AND CHARWOMEN	668.000	1.463	.00219	669.463	4.381	.00656	672.381
364 JANITORS AND SEXTONS	1218.000	5.694	.00467	1223.694	11.908	.00978	1229.908
365 BARTENDERS	201.000	0.000	0.00000	201.000	.882	.00439	201.882
366 BUSBOYS	139.000	.004	.00003	139.004	.544	.00392	139.544
367 COOKS, EXC PRIVATE	866.000	.095	.00011	866.095	3.065	.00354	869.065
368 DISHWASHERS	218.000	.020	.00009	218.020	.750	.00344	218.750
369 FOOD COUNTER, FOUNTAIN WORKERS	307.000	.062	.00020	307.062	1.149	.00374	308.149
370 WAITERS	1124.000	.051	.00005	1124.051	5.102	.00454	1129.102
371 FOOD WORKERS, NEC, EXC PRIVATE	408.000	.110	.00027	408.110	.994	.00244	408.994
372 DENTAL ASSISTANTS	94.000	.000	.00000	94.000	.044	.00046	94.044
373 HEALTH AIDES, EXCEPT NURSING	148.000	.003	.00002	148.003	.073	.00049	148.073
374 HEALTH TRAINEES	9.000	0.000	0.00000	9.000	.003	.00029	9.003
375 LAY MIDWIVES	0.000	0.000	0.00000	0.000	0.000	0.00000	0.000
376 NURSES AIDES, ORDERLIES	912.000	.020	.00002	912.020	.348	.00036	912.348
377 PRACTICAL NURSES	343.000	.017	.00005	343.017	.148	.00043	343.148
378 AIRLINE STEWARDESSES	31.000	0.000	0.00000	31.000	.258	.00832	31.258
379 ATTN, RECREATION, AMUSEMENT	125.000	.003	.00002	125.003	.206	.00165	125.206
380 ATTN, PERSONAL SERVICE, NEC	83.000	.063	.00075	83.063	.268	.00323	83.268
381 BAGGAGE PORTERS AND BELLHOPS	21.000	.003	.00015	21.003	.053	.00251	21.053
382 BARBERS	157.000	.000	.00000	157.000	.060	.00039	157.060
383 BOARDING, LODGING HOUSEKEEPERS	12.000	0.000	0.00000	12.000	.004	.00031	12.004
384 BOOTBLACKS	5.000	0.000	0.00000	5.000	.004	.00070	5.004
385 CHILD CARE WORKERS, EXC PRIVATE	356.000	.001	.00000	356.001	.162	.00045	356.162
386 ELEVATOR OPERATORS	41.000	.104	.00293	41.104	.265	.00646	41.265
387 HAIRDRESSERS, COSMETOLOGISTS	498.000	.000	.00000	498.000	.263	.00053	498.263
388 HOUSEKEEPERS, EXC PRIVATE	117.000	.015	.00012	117.015	.209	.00179	117.209
389 PERSONAL SERVICE APPREN	3.000	.000	.00003	3.000	.002	.00062	3.002
390 SCHOOL MONITORS	48.000	0.000	0.00000	48.000	.002	.00004	48.002
391 USHERS, RECREATION, AMUSEMENT	11.000	0.000	0.00000	11.000	.023	.00209	11.023
392 WELFARE SERVICE AIDES	34.000	0.000	0.00000	34.000	.013	.00037	34.013
393 CROSSING GUARD, BRIDGETENDERS	49.000	.007	.00015	49.007	.056	.00114	49.056
394 FIREMEN, FIRE PROTECTION	200.000	.060	.00030	200.060	.126	.00063	200.126
395 GUARDS AND WATCHMEN	412.000	2.017	.00490	414.017	5.066	.01230	417.066
396 MARSHALS AND CONSTABLES	8.000	0.000	0.00000	8.000	0.000	0.00000	8.000
397 POLICEMEN AND DETECTIVES	416.000	.031	.00007	416.031	.234	.00056	416.234
398 SHERIFFS AND BAILIFFS	59.000	0.000	0.00000	59.000	0.000	0.00000	59.000
399 CHILD CARE WORKERS	543.000	0.000	0.00000	543.000	0.000	0.00000	543.000
400 COOKS, PRIVATE	40.000	0.000	0.00000	40.000	0.000	0.00000	40.000
401 HOUSEKEEPERS, PRIVATE	112.000	0.000	0.00000	112.000	0.000	0.00000	112.000
402 LAUNDRESSES, PRIVATE	29.000	0.000	0.00000	29.000	0.000	0.00000	29.000
403 MAIDS, SERVANTS, PRIVATE	713.000	0.000	0.00000	713.000	0.000	0.00000	713.000
404 ANIMAL CARETAKERS, EXC FARM	80.000	.002	.00002	80.002	.160	.00200	80.160
405 CARPENTERS, HELPERS	125.000	.264	.00211	125.264	.693	.00554	125.693
406 CONSTR LABR, EXC CARPENTER HELP	818.000	1.441	.00176	819.441	3.950	.00483	821.950
407 FISHERMEN AND OYSTERMEN	36.000	0.000	0.00000	36.000	.212	.00588	36.212
408 FREIGHT, MATERIAL HANDLERS	761.000	8.386	.01102	769.386	16.830	.02212	777.830
409 GARBAGE COLLECTORS	85.000	.004	.00005	85.004	.454	.00534	85.454
410 GARDENRS, GROUNDKEEPER, EXC FARM	544.000	.216	.00040	544.216	.952	.00175	544.952
411 LONGSHOREMEN AND STEVEDORES	53.000	.005	.00009	53.005	.365	.00688	53.365
412 LUMBERMEN, RAFTSMEN, WOODCHOPPERS	81.000	.004	.00005	81.004	.627	.00774	81.627
413 STOCK HANDLERS	723.000	2.286	.00316	725.286	6.341	.00877	729.341
414 TEAMSTERS	7.000	.043	.00619	7.043	.107	.01530	7.107
415 VEHICLE WASHR, EQUIP CLEANERS	176.000	1.277	.00725	177.277	2.597	.01474	178.597
416 WAREHOUSEMEN, NEC	150.000	.503	.00336	150.503	1.396	.00931	151.396
417 OTHER LABORERS	580.000	9.715	.01675	589.715	20.202	.03483	600.202
418 FARMERS (OWNERS AND TENANTS)	1658.000	0.000	0.00000	1658.000	2.221	.00135	1660.221
419 FARM MANAGERS	30.000	0.000	0.00000	30.000	.041	.00134	30.041
420 FARM FOREMEN	28.000	0.000	0.00000	28.000	.039	.00139	28.039
421 FARM LABORERS, WAGE WORKERS	884.000	0.000	0.00000	884.000	1.212	.00137	887.212
422 FARM LABORERS, UNPAID FAMILY	455.000	0.000	0.00000	455.000	.613	.00135	455.613

Table VII. (continued)

423 FARM LABORERS, SELF-EMPL	11.000	0.000	0.00000	11.000	.017	.00151	11.017
CONSTRUCTION OF 10 GW CAPACITY OF SOLAR POWER.							

Table VIII. Effluent Release Due to the Construction of 10 GWe Capacity of Central Receiver Power Plants Assuming 1990 EPA Emission Standards.

EFFLUENT		UNITS ARE TONS				
		(1)	(2)	(3)	(4)	(5)
		1972 NET EFFLUENTS (1990 EPA STANDARDS)	EFFLUENT INCREASE FROM DIRECT INCREASE DEMAND	(2)/(1)	EFFLUENT INCREASE FROM CUMULATIVE INCREASE DEMAND	(4)/(1)
1PARTICULATES	NOT APPLICABLE	.26302589E+07	.54488587E+05	.207E-01	.98119221E+05	.373E-01
2	ARSENIC	.42765446E+02	0.	0.	.43641192E+00	.102E-01
3	ASBESTOS	.11159040E+04	.30422873E+02	.273E-01	.45315896E+02	.406E-01
4	BERYLLIUM	.10056584E+02	0.	0.	.10248419E+00	.102E-01
5	CADMIUM	.69836200E-02	0.	0.	.39795411E-03	.570E-01
6	CHROMIUM	.64002080E+03	0.	0.	.65083978E-01	.102E-01
7	FLUORINE	.39874788E+04	.16733963E+02	.420E-02	.64206368E-02	.161E-01
8	LEAD	.13127313E+04	0.	0.	.71291156E-02	.543E-01
9	SELENIUM	.47246989E+02	0.	0.	.48048173E-00	.102E-01
10	VANADIUM	.12739716E+03	0.	0.	.12955070E-01	.102E-01
11	ZINC	.25371196E+04	0.	0.	.14457505E-03	.570E-01
12SULFUR OXIDES	NOT APPLICABLE	.69532827E+07	.19218752E+05	.276E-02	.11047411E+06	.159E-01
13NITROGEN OXIDES	NOT APPLICABLE	.68968696E+07	.12785693E+05	.185E-02	.90358045E+05	.131E-01
14HYDROCARBONS	NOT APPLICABLE	.53944673E+06	.22815856E+04	.423E-02	.93064931E+04	.172E-01
15CARBON MONOXIDE	NOT APPLICABLE	.53117685E+07	.16757367E+06	.315E-01	.52764663E+06	.993E-01
16OTHER GASES AND MISTS	NOT APPLICABLE	.90437000E+04	.63202220E+02	.699E-02	.19897704E+03	.220E-01
17	CHLORINE	.39457575E+04	.63391918E+02	.161E-01	.12974449E+03	.329E-01
18	MERCURY	.26074086E+03	.11698128E+01	.449E-02	.43053000E+01	.165E-01
19BIOLOGICAL OXYGEN DEMAND	NOT APPLICABLE	.34770941E+06	.19166543E+03	.551E-03	.28252059E+04	.813E-02
20CHEMICAL OXYGEN DEMAND	NOT APPLICABLE	.10283813E+07	.19820195E+04	.193E-02	.10040639E+05	.976E-02
21SUSPENDED SOLIDS	NOT APPLICABLE	.26493663E+06	.65917940E+03	.249E-02	.406649759E+04	.154E-01
22	PHENOLS	.16252648E+03	.20054424E+01	.123E-01	.61155471E+01	.376E-01
23DISSOLVED SOLIDS	NOT APPLICABLE	.52814312E+07	.56515450E+05	.107E-01	.13360577E+06	.253E-01
24	ALUMINUM	0.	0.	0.	0.	0.
25	ARSENIC	.14031212E+01	0.	0.	.79955366E-01	.570E-01
26	CADMIUM	.24534815E+01	0.	0.	.13980902E+00	.570E-01
27	CHROMIUM	.25190514E+03	.71282034E+00	.283E-02	.41072481E+01	.163E-01
28	COPPER	.61185643E+03	.42513243E+00	.695E-03	.68239103E+01	.112E-01
29	CYANIDE	.81279416E+02	.28957115E+01	.356E-01	.91111680E+01	.112E+00
30	FERROUS METALS	.28455341E+05	.33296910E+02	.117E-02	.37664180E+03	.132E-01
31	FLUORINE	.18655577E+04	.53562704E+02	.287E-01	.18935839E+03	.102E+00
32	LEAD	.19883683E+02	.36375474E+00	.183E-01	.84751008E+00	.426E-01
33	MERCURY	.16716387E+00	.26180383E-02	.157E-01	.55980847E-02	.335E-01
34	MISC NONFERROUS METALS	.91255350E+02	.32557895E+01	.357E-01	.10248348E+02	.112E+00
35	SELENIUM	.27501200E+01	0.	0.	.15671265E+00	.570E-01
36	ZINC	.43602309E+03	.58154408E+00	.133E-02	.72656664E+01	.167E-01
37NUTRIENTS	NITRATES	.20458955E+05	.32613179E+03	.159E-01	.67005446E+03	.328E-01
38	PHOSPHATES	.29927985E+02	.10677645E+01	.357E-01	.33610349E+01	.112E+00
39ACIDS	NOT APPLICABLE	.77025000E+01	.12374715E+00	.161E-01	.25327378E+00	.329E-01
40BASES	NOT APPLICABLE	.24314021E+05	.25248312E+03	.104E-01	.64352636E+03	.265E-01
41OILS AND GREASES	NOT APPLICABLE	.17142919E+05	.26122211E+03	.152E-01	.68781665E+03	.401E-01
42WASTE WATER	NOT APPLICABLE	.25601014E+07	.38162323E+05	.149E-01	.13518182E+06	.528E-01
43INDUSTRIAL SLUDGES	NOT APPLICABLE	.68746292E+06	0.	0.	.45979144E+04	.669E-02

Machine Products, the I/O category definition includes only those industries primarily engaged in stamping and screw machine operations (SIC codes 345 and 346). The definition excludes all industries whose primary function is to produce something else, but which do considerable stamping and screw machine work (e.g. the automobile industry). A similar situation holds for General Industrial Machinery and Heating, Plumbing, and Structural categories. The increase in the engines and turbines category is also somewhat misleading because roughly the same amount of generating equipment would be required to build any kind of intermediate load power plant, be it fossil or CR. Of course a fossil scenario would affect the other industries also, but the increases would not be nearly as large as for the CR on these because of the much lower industrial activity needed to build fossil plants compared with CR plants for these other categories. With these provisos, the maximum increase over 1972 levels on any industry due to the CR scenario is probably about 15%.

The employment model predicts that the following occupations would be most affected by this scenario, with percent increases in jobs relative to 1972 also shown:

Forgemen and Hammermen	-	13%
Job and Die Setters, Metal	-	11%
Rollers and Finishers, Metal	-	11%
Heater, Metal	-	10%
Other Precision Machine Operatives	-	10%
Punch Stamping Press Operatives	-	12%

These estimates provide the best basis for analyzing the effects of this scenario on the U.S. economy. The maximum occupations are increased from 10 to 15% by the CR construction scenario.

Five effluent types would experience 10% increases or more over the 1972 net industrial levels with 1990 controls, these are:

Carbon Monoxide	-	10%
Dissolved Cyanide	-	11%
Dissolved Flourine	-	10%
Dissolved Miscellaneous		
Non-Ferrous Metals	-	11%
Dissolved Phosphates	-	11%

These estimates for jobs and effluents include all industries and do not suffer from the problems which were encountered in looking at increases on the various industry categories.

#### H. Water Requirements

Water requirements are of concern in the southwest for most energy technologies (fossil and nuclear, as well as solar). However the requirements perhaps merit special attention for solar since the CR is subject to constraints (availability of sunshine and inexpensive land) not imposed to the same degree on the other technologies and which favor arid locations.

Rankine (steam) and closed-cycle Brayton engines require cooling devices. The options are: wet cooling towers (either free or mechanical draft), dry cooling towers, cooling ponds, and once through cooling

(when feasible). Once-through cooling would apply only to very special cases. Most often considered are wet towers, ponds, and dry cooling towers. The latter are more expensive to construct and exert a further cost penalty by lowering the conversion efficiency of the solar plant. Consider, then, the evaporative devices. The water requirements are roughly the same for all such devices within, say, a factor of 2, since most of the waste heat goes into evaporating the water. To be specific, then, consider mechanical draft cooling towers. The water requirements for this device are given for different water resource regions by Espey, Huston, & Associates (1974). A 100 MWe plant in the southwest would require about  $2.36 \times 10^5$  liters/hr, or  $8.1 \times 10^5$  gallons/day assuming daily energy output of 300 MWhr. Table IX shows water use in 1965 and the projected use in 1980 and 2000 by water resource region (Water Resource Council, 1968). The Espey, Huston report also estimates water surpluses by region in the year 1980 and 2000 (see Table X this report). Based on this information, it appears likely that the Rio Grande, California, Great Basin, Upper Colorado, and Lower Colorado water resource regions will experience shortages by the year 2000. Suppose the 100 GWe of installed CR capacity discussed above occurs by the early 21st century. This much power would require about  $8.1 \times 10^8$  gallons/day if evaporative devices were used. This usage would add significantly to the strain on the water supply in the southwest. Increased population in the southwest due to the presence of the central receiver plants would increase the demand on water even more, although no model for this demand is presented here. In view of these water requirements, significant implementation of Rankine

Table IX. Estimated Water Use and Projected Requirements, by Regions, United States<sup>1</sup> (millions of gallons daily)

Region	used	Projections	
	1965	1980	2000
North Atlantic	2,023	2,870	4,960
South Atlantic - Gulf	2,695	3,395	5,655
Great Lakes	1,199	1,881	3,183
Ohio	1,134	1,619	2,539
Tennessee	331	572	834
Upper Mississippi	770	1,103	1,778
Lower Mississippi	1,470	3,012	4,453
Souris-Red-Rainy	77	215	494
Missouri	10,554	13,160	14,979
Arkansas-White-Red	5,874	8,482	10,587
Texas-Gulf	7,289	9,435	10,890
Rio Grande	4,403	4,676	4,991
Upper Colorado	1,982	2,700	3,100
Lower Colorado	3,448	4,075	4,645
Great Basin	2,253	3,299	3,562
Columbia-North Pacific	10,521	13,581	17,325
California	20,944	29,205	32,660
Alaska	12	50	96
Hawaii	533	728	1,000
Puerto Rico	270	360	475
<b>Total</b>	<b>269,617</b>	<b>104,418</b>	<b>128,206</b>

<sup>1</sup> Taken from Water Resources Council Report (1968).

Table X. Estimates of Surplus Fresh Water Based on Annual Flows Available 90 and 95% of Years and Total Freshwater Consumptive Use, Excluding Steam-Electric Power, for Years 1980 and 2000.

<u>Water Resource Region</u>	(Billion Gallons Per Day)			
	90%		95%	
	<u>1980</u>	<u>2000</u>	<u>1980</u>	<u>2000</u>
1. New England	114	110	103	99
2. Middle Atlantic				
3. South Atlantic - Gulf	127	124	112	109
4. Great Lakes	43	40	39	36
5. Ohio	78	77	65	64
6. Tennessee	28	27	24	23
7. Upper Mississippi	34.7	33.7	26.8	25.8
8. Lower Mississippi	27.2	25.9	22.1	20.8
9. Souris - Red - Rainy	18.3	16.1	11.6	9.4
10. Missouri Basin				
11. Arkansas - White - Red	35.9	34.9	25	24
12. Texas - Gulf	5.0	3.9	0.6	-0.5
13. Rio Grande	-2.2	-2.0	-2.7	-2.5
14. Upper Colorado	-2.2	-2.0	-3.6	-3.4
15. Lower Colorado				
16. Great Basin	-2.3	-.17	-3.0	-2.4
17. Pacific Northwest	140	139	124	123
18. California	2.4	-1.8	-5.7	-10.0
<b>Total</b>	<b>646.9</b>	<b>624</b>	<b>538.1</b>	<b>515.2</b>

Negative sign implies water shortage.

Estimates of annual flows available 90 and 95% of years based on Water Resources Council (1968).

Estimates of consumptive use based on Wollman and Bonem (1971).

"Medium" projection.

Taken from Espey, Huston (1974).



or close-cycle Brayton systems will probably require the use of dry cooling towers.

#### I. Land Requirements

As discussed in Section II, a 100 MW<sub>e</sub> intermediate load CR plant would require about 3 km<sup>2</sup> of land, not including access roads and transmission line right of ways. The Aerospace study (Aerospace, 1974) did a siting analysis of the southwest U.S. and in their most stringent case found 55,000 km<sup>2</sup> of land suitable for CR use. The entire electrical demand in the U.S. averages out to about 200 GW<sub>e</sub>, or an annual energy demand of about 1.7 million GWh. This demand would require about 3,690 100 MW<sub>e</sub> CR plants to meet it, or a land area of 11,800 km<sup>2</sup>. There is, then, sufficient land that is suitable for CRs. Whether the use of this land for power generation will be acceptable is a subject beyond the scope of this paper. However, some aspects of this land use are treated in the following sections.

#### IV. Ecological Impacts

Central receiver plants would most likely be constructed in arid or semi-arid regions. The wildlife is certain to be affected during the construction of the plants (when construction vehicles and activities will severely alter the local ecosystem), and after construction, when the physical presence of the plant would permanently modify the natural habitat. The most obvious effect is that large land areas would be roughly half-covered with heliostats. The native ecosystems in such areas would essentially be destroyed. The replacement ecosystem will depend on, among other things, the details of the heliostat field. Some designs would require the land to be paved, or to have herbicides applied to prevent vegetation from interfering with heliostat operations. Other designs could have vegetation under the mirrors. The micro-climate under the mirrors will be cooler, less windy, and probably more moist than for natural conditions. This environment might support different types of plants, or faster growth rates than normal. Some people have suggested that the heliostat fields would be suitable for limited agriculture, such as grazing of herbivores.

A general consensus is emerging among ecologists that at least a part of the deserts of the U.S. should be left largely untouched by man's activities and left as close as possible to its natural state. The amount of land to be left thus preserved is a matter of considerable and often intense debate between ecologists and conservationists on the one hand, and opponents ranging from land developers to industrialists to government planners on the other. The introduction of central receivers or other desert solar technologies such as photovoltaic systems will undoubtedly

accentuate these issues and intensify the debate. The ecological acceptability of devoting land in semi-arid areas to heliostat fields will depend on many factors; the impact from the specific siting of the solar facility (e.g., the presence or absence of endangered species), the impact of the construction of the facility, the impact of the expected increase in industry and human population, and the alternatives (i.e., other energy technologies).

A major ecological concern in deserts in recent years has been the adverse effects of off-road vehicles on desert ecosystems (Stebbins, 1974; Wilshire, 1976). Their weight is capable of crushing burrowing animals, their tracks can increase water erosion and runoff, they can noticeably increase dustiness and turbidity in a region, and their noise levels may be harmful to the hearing and tranquility of some desert species. To varying degrees, off-road vehicles used in the construction of solar plants will have similar effects.

The direct kill of wildlife may be an important problem during the construction of the plants because many desert animals spend most of the sunlit hours underground, where it is cooler and moister than the hot arid surface. (The heat of the desert sun rarely penetrates more than a few inches beneath the surface.) The magnitude of the effect will depend upon the amount of generating capacity installed in the region and the tonnage of the trucks used for hauling. It will also depend on soil strength at the site, and on the type and width of roads which will be used for hauling. Another important factor will be the population of animals at the site and their burrowing habits. Sites near water holes or springs are likely to contain large numbers of animals, whereas playas or dry drainage basins

have relatively little animal or plant life, and may therefore be more appropriate locations for solar plants. However, playas flood on occasion, presenting a technical problem for such siting.

Fine materials are abundant in the desert, but they are usually formed at the surface into a thin crust. It protects the underlying fines from erosion, especially wind erosion. This crust may be up to 6mm thick. It is quite widespread, but good estimates of exactly what percentage of the desert surface is covered by it are not available. It is delicate and fragile in many places, and water can penetrate it. The details of how the crust forms are still a matter of some debate. Compaction resulting from rainfall has been suggested as a mechanism for its formation. It is bound by chemical cementing of grains which may, in some areas, be promoted by lichen or algae growth. Fungal filaments may also contribute to the crust in areas where there is organic matter in the soil.

The presence of construction vehicles and workers at and in the vicinity of the solar plant will damage this crust (when present), and this damage will accelerate wind erosion. In addition, the increased population of the region resulting from the presence of the plant may lead to increased recreational demands on the surrounding deserts. If these demands include off-road vehicle activity, then there will be additional destructive effects on desert crusts. Conservationists are presently trying to limit this off-road traffic (for example the annual Barstow to Vegas motorcycle race) and if they are successful then this latter problem could be considerably reduced.

Dust is almost certainly going to be a major problem for the successful operation of central receiver power plants. Atmospheric dust particulates decrease the amount of direct solar radiation reaching the surface and also reduce heliostat mirror reflectivity. One possibility is that the entire land area of the solar plant be paved with concrete or asphalt. Such paving has already taken place, for example, at the 5 MW<sub>t</sub> test facility at Albuquerque. If paving occurred, then the local ecosystem would be more drastically modified than without it. Because of the natural sealing properties of the desert crust, it might be possible to develop ways of strengthening the crust and making it form more quickly, and thereby reducing dust in the vicinity of the plant. This quasi-natural solution to the problem might be both cheaper and more environmentally acceptable than paving.

Since the crust acts as a sealant for the fines beneath the surface, when it is broken an increase in atmospheric turbidity can be expected. Increased wind erosion and degradation of soil quality can occur, resulting in less flora and fauna in the area affected. Some meteorologists believe that increased dustiness in a desert region can affect the climate, as will be discussed more fully in the chapter devoted to climate.

Over a period of many years, many areas of deserts have developed a surface of fairly densely-packed pebbles and stones known as desert pavement (Fuller, 1974). It forms from pebbles and cobbles accumulated on dry land as a result of wind or water carrying away the finer particles

of sand, silt, or clay\*. The stones of the pavement typically vary in size from 0.5 cm to 20 cm. They are cemented together or encrusted with various salts, gypsum, lime, and silicates, and are often coated with a desert varnish. The pavement retards erosion and water runoff. When it is broken by off-road vehicles, considerable wind and water erosion can result. Increased water runoff due to broken crust will decrease the sparse water available for life in the vicinity. These effects can be expected to occur during construction of the central receiver plants as the result of road building and construction vehicles.

The water cycle in arid regions is extremely important to all forms of wildlife, and any modification of this cycle could affect the local ecosystem. A very rough picture of the hydrological cycle is as follows (Davis, 1974). Rains usually occur in mountains or over alluvial fans, changing the water table in the high grounds. The ground water then flows slowly as a result of gravity and pressure forces to lower lying basins or plains. Large amounts of water are evaporated in the playas, which are low-lying saline flats covering vast areas which are often subject to flooding and are sometimes the remnants of ancient lakes. As mentioned earlier, playas may be suitable for solar energy facilities. The building of central receiver plants will affect the hydrologic cycle in several ways wherever they are built. During construction, tracks left by off-road construction vehicles may become gulleys as a result

---

\*In the Wentworth particle size classification scheme the grid sizes which define various sizes are: Boulder >256mm, 256mm >cobble >64mm, 64mm >pebble >2mm, 2mm >sand >1/16mm >silt >1/256mm, 1/256mm >clay.

of water erosion, which would tend to increase water runoff. Access road construction will also increase run-off.

The partially shaded region beneath the heliostat canopy will experience reduced evaporation. In particular, the water retention time in the soil of the heliostat field after a storm will be increased. As a result, some additional rainwater may reach the water table, although this effect is not likely to be very significant. Dew can play an important role in the hydrologic cycle of arid regions. In the heliostat canopy we can expect more dew formation overnight than in the natural state because of the larger area on which condensation can occur. As a result of shading this dew will evaporate less quickly in the morning.

Population densities of different species by geographic location in the southwest do not exist in great detail. Most information is spotty, with some species or regions studied in great detail and others hardly at all. The Office of Arid Lands Institute in Tucson, Arizona maintains a bibliography with abstracts on works pertaining to deserts. A review of this data base was prepared in 1968 (McGinnies, 1968) which contains a concise, although certainly not complete description of the state of knowledge of the world's deserts. Much important work was carried out by the U.N. Arid Zone Institute.

Central receiver plants will destroy habitats over large areas for many desert species (flora and fauna). Of paramount concern among these are those that are threatened, rare, or endangered and also likely to be affected. Many of these species or subspecies (taxon) are protected by law. We shall not include flora in the following discussion, although they ought to be examined at some point.

Of the many threatened types of wildlife of North America, only a few could be adversely affected by the CR plant. These have ranges in the southwest which include regions which are suitable for CR plant construction. Taxon with extensive ranges, even if occurring in regions suitable for the CR, are not likely to be particularly threatened by the construction of CR plants so long as the fraction that the CR area makes with the total range of the species is small. In this case, one might expect that the fraction of the animals killed would roughly be the ratio of the CR area in the range with the total area of the range. Of much greater concern are species which are well-localized, threatened, and occur in locations suitable for CR plants. Migratory birds which spend part of the year well-localized in a region suitable for CR's (such as the Tule White-Fronted Goose) must be included in this list. The following is a list of such species with a brief description of their range and relevant facts about their habitats. This list may not be complete, as new species are continually being added to the threatened species lists. The geographic distribution of these animals, when known, should be used as a siting consideration in constructing central receiver plants. In constructing the list, the decision as to whether a given range was localized or not was purely judgmental.

#### MAMMALS

Sonoran Pronghorn - Ranges in U.S. mostly on Cabeza Prieta Game Range and Organ Pipe Cactus Nat. Mon. in SW Arizona, Range extends southward into Mexico to an unknown line north of Hermosillo. Preferred habitat is isolated desert grassland on sandy soil.



Mexican Wolf - Its range extends from extreme southern Arizona, east to West Texas, and south to San Luis Potosi in Mexico. Apparently extirpated from U.S. in 1940's, but recently reappeared in Arizona and Texas.

Mojave Ground Squirrel - Historically occurred in the Mojave Desert west to Palmdale, north to Haiwee Mesa, and south to Rabbit Springs near Hesperia. Present numbers and distribution are unknown. Accelerated urbanization and land use changes in Mojave River Basin and Antelope Valley are destroying most of its habitat.

Stephan's Kangaroo Rat - Historically found only in San Jacinto Valley, Riverside County, and extreme southern San Bernadino Valley. Distribution and numbers not presently known. Inhabits sandy soil; not adapted to urbanized areas.

San Joaquin Kit Fox - Ranges in foothills of Tehachapi Mountains, at southern end of San Joaquin Valley, north along foothills of western San Joaquin Valley to Los Banos, and north on eastern edge of San Joaquin Valley to Portersville. Restricted to areas of native vegetation supporting Kangaroo Rats. Probably 1000 to 3000 animals, with highest concentration at southernmost end of San Joaquin Valley. Conversion of scrub valley land to irrigation agriculture and urbanization has diminished known historical range.

Tule Elk - Ranges in three well-separated places in California: Cache Creek, Owens Valley, and Tule Elk State Park near Tupman. This latter is fenced, the former two are free-roaming. Transplants to various areas have been attempted, some attempts abandoned, some yet undecided, others planned. Its habitats are grasslands, woodlands, and moderately brushy valleys and foothills.

Red Wolf - Range includes southeast part of Texas, mostly between Galveston Bay and Sabine Lake, Eastern Chambers and Southern Jefferson counties. Probably some also in southern Liberty and eastern Brazoria counties, southwest Louisiana, in Cameron and Vermilion parishes. Originally found in many kinds of habitat in Southern U.S., and probably could survive wherever food is sufficient. Its last major refuges are unmodified bottomland forests and swamps, and large stretches of coastal marsh. Maintenance of such habitat would probably be of importance in any effort to save the species. Although these areas are not prime candidates for central receivers, they could be suitable.

Utah Prairie Dog - Now reported only in six counties in South-Central Utah, at higher elevations. Wayne, Garfield, and Iron counties are the ones with significant populations.

#### BIRDS

Mexican Duck - Extremely localized in southeastern Arizona, southern New Mexico, and central western Texas. Winters south of the border. Inhabits fresh marshes, irrigated land, grainfields, ponds, rivers, lakes, and bays. Nests in marsh with reeds or grass, rarely otherwise. Possibly 500 in the U.S.

Masked Bobwhite - Now definitely known in only two locations between 1500 and 2500 feet elevation in central portion of state of Sonora Mexico. Formerly the range extended north into Arizona at Nogales and Sasabe. Inhabits desert or arid grassland with sparse woody overstory.

Yuma Clapper Rail - Nests from Colorado river delta in Mexico north in marshes along river to Needles, CA, with main concentrations in Havasu Lake, Cibola, and Imperial Nat. Wildlife refuges; at lower end of Salton

Sea; along lower Gila River between Wellton and Mohawk Valley in Arizona, especially north of Tacna, and potentially in Dome Valley, Gila or Salt River near Telleston, Arizona; Granite Reef Dam on Salt River above Mesa, Arizona; potential habitat developing at Alamosa reservoir on Bill Williams River near Alamosa Crossing, Arizona. Birds migrate, but winter range is unknown at this time. Inhabits wet ground covered by permanent vegetation exceeding two feet in height, usually with some open water present.

Central receiver plants could encroach on this habitat.

California Black Rail - Range includes Tomales Bay and San Francisco, south to Baja, CA; casually inland to Stockton, Riverside, and Salton Sea; along lower Colorado river. Could suffer some habitat destruction as a result of central receivers. Probably not a major concern since it ventures inland only infrequently.

Tule White - Fronted Goose - The species is circumpolar and common. The Tule Goose subspecies is known only from two populations, one migrating through Pacific States and the other through the Great Plains. Pacific birds winter in Central California which is reason for concern here; migrants recorded in Western Oregon and as far south as Northwestern New Mexico. Also known to winter at Tule lake and vicinity in Northern California and adjacent Oregon. Breeding area for Pacific birds is unknown. Great Plains Population migrates through Saskatchewan south to Texas and Louisiana; at least some breed in Northern Yukon Territory, Canada. Central receivers could destroy habitat in some of the wintering areas. Probably not a large threat to this species, however.

Lesser Prairie Chicken - Resident locally in southeast Colorado, west Kansas, west Oklahoma, east New Mexico, and northwest Texas (panhandle). Said to be established on Hihoa (Hawaiian island). Very localized, and much reduced or extirpated from large portions of its former range. Inhabits sandhill country, in sagebrush, bluestem grass, and oak shinnery; ideally, grassland, interspersed with patches of shinnery oak.

North Greater Prairie Chicken - Resident locally in Prairie and other grassland habitat from eastern North Dakota and northwest Minnesota south to northeastern Colorado, and south central Oklahoma east to central Michigan, northwest Indiana, and south central Illinois, very localized, and much reduced or extirpated from most of its former range, particularly in the more optimum habitat of the midwestern tall grass prairies, formerly through prairie eastward to Ohio and Kentucky.

Attwater's Greater Prairie Chicken - Very local in small, disjunct populations in the gulf coastal prairie of Texas, scattered over 11 counties but chiefly in Refugio and Colorado counties. Formerly ranged over entire gulf coastal prairie from southeast Louisiana westward to Nueces River. Inhabits prairie, especially with patches of wild rose, sunflowers, and similar plants offering shelter and food.

Golden - Cheeked Warbler - Breeds only in Texas; mainly in Edwards Plateau, west to San Angelo and Rocksprings, east locally to Austin and San Antonio. Winters in southern Mexico to Nicaragua. Inhabits Junipers, Oaks, and also streamside trees. Population estimated between 15,000 and 17,000 total. Common in areas of mature Cedar. Loss of this habitat has extirpated the species in many places. Urbanization and brush eradication for improved range threatens its habitat.

AMPHIBIANS AND REPTILES

Blunt Nosed Leopard Lizard - A sub species of the leopard lizards, found in San Joaquin Valley and surrounding foothills, CA.

Black Toad or Inyo County Toad - Subspecies of the western toad. Found in Deep Springs Valley, Inyo County, CA.

Table XI shows those species from the above list found in each southwestern state. In addition to these, there may be fish or invertebrate which could conceivably be affected by the plants. For example, the aquatic habitat of fish could be modified by cooling devices for the plants, or conceivably by the construction activity in building the CR. The CR's could also have unexpected effects on some species not included in the list. Migrating Birds, for example, could be affected adversely by the glare from the heliostat field, or the food chain of some non-desert creature may be disrupted by the plants. Indirect effects of demographic shifts to the southwest due in part to the construction of the plants might also destroy habitats for some of these species.

It is not certain that any of the threatened species listed will actually suffer population reductions. If the siting of the CR plants can avoid their ranges, then it is hard to see how the CR could affect their populations. To a large extent, the degree to which the CR plants will affect them will depend on how much freedom exists in plant siting. A number of considerations restrict the area suitable to CR plants in the southwest. The Aerospace Study (1974) examined siting restrictions under two different sets of criteria. In the most stringent case, about 21,546 sq. mi. were available for the CR plant. In the least stringent

Table XI. Threatened Taxon Which Might Be Affected by the Central Receiver Power Plant.

---

<u>State</u>	<u>Threatened Taxon</u>
Arizona	Sonoran Pronghorn, Mexican Wolf, Mexican Duck, Masked Bobwhite, Yuma Clapper Rail, California Black Rail
California	Mojave Ground Squirrel, Stephan's Kangaroo Rat, San Joaquin Kit Fox, Tule Elk, Tule White - Fronted Goose, Yuma Clapper Rail, Blunt Nosed Leopard Lizard, Black Toad
Colorado	Lesser Prairie Chicken
Kansas	Northern Greater Prairie Chicken, Lesser Prairie Chicken
Nevada	None
New Mexico	Mexican Wolf, Lesser Prairie Chicken, Mexican Duck
Oklahoma	Northern Greater Prairie Chicken, Lesser Prairie Chicken
Texas	Red Wolf, Mexican Wolf, Mexican Duck, Attwater's Greater Prairie Chicken, Lesser Prairie Chicken
Utah	Utah Prairie Dog

---

case, about 161,190 sq. mi. were available. In order to supply the entire U.S. electrical needs, approximately 4,500 sq. mi. of land would be required. This makes up about 3% of the least stringent area, and about 21% in the most stringent case. The Aerospace study did not include threatened species in its siting criteria in either case. In the least stringent case, it is likely then that CR plants could be sited without encroaching on threatened species. In the most stringent case, this would be more difficult, but a more realistic scenario of perhaps 100 GW<sub>e</sub> of CR plants would present fewer problems. Thus, with care, and careful siting, harmful effects to threatened species can probably be avoided, or at least minimized. As a relatively minor consideration, some animals may be able to exist even with the CR's in place.

## V. Climatological Considerations

### A. Overview

As technology progresses, man's ability to modify his environment is increasing at a dramatic rate. Fortunately, coincident with this growth there has been a parallel development in man's understanding of his natural environment and the many and varied feedback mechanisms which interconnect the myriad of processes which support our natural ecosystem. The increase in understanding of climate is a case in point. With the advent of high speed computers and a better understanding of the primitive equations underlying the dynamics of the atmosphere, semi-realistic climate modelling has become a possibility. Some of the activities which are cause for concern with respect to possible climate modification are: the advent of nuclear weapons, the tremendous growth in the consumption of energy (thermal pollution), the large increase in the burning of fossil fuels and the concurrent buildup of atmospheric CO<sub>2</sub>, the increase of air traffic and in particular the SST's and the future possibilities of extensive space shuttle traffic, increased use of nitrogen fertilizer and possible effects on the ozone layer, etc. The potential climate modification which might be caused by new technologies should be studied so that reasonably informed decisions can be made.

Solar CR plants will modify to some extent the local climate. In addition, if built on a large enough scale, the plants could conceivably modify regional or global climates. This could happen if enough plants were built so as to significantly affect the average surface albedo of a region; to increase significantly the amount of water vapor introduced



into the atmosphere over the desert; or to introduce sufficient dust into the atmosphere to modify the regional planetary albedo. At the regional scale (with many plants in one area) the solar plants could alter to some extent the downwind weather. Increased cloudiness could be one effect. At the global scale (many plants worldwide) there could be changes in the global temperature distribution, precipitation patterns, alteration of the atmospheric general circulation pattern, and/or changes in the size of the polar ice caps. To maintain perspective, it must be pointed out that the alternatives to solar energy, fossil fuel consumption and nuclear power, would also affect climate.

At present the CR concept is viewed as a source for intermediate load power only (see sections II and III). However, the potential for base load plants (with energy storage) or synthetic fuel production is a possibility for the long term. Only with this possibility can one envision construction scenarios which could cause a noticeable perturbation on global climate. While there is no certainty that CR plants will be used globally, this possibility will be considered in the below discussion.

Generally, models on three scales are used to study the climate. Microscale models usually are limited to an area of a few square kilometers. Mesoscale (or regional) models may deal with areas of thousands of square kilometers, and global models deal with the whole planet.

Numerous models have been written for each of these scales. We shall apply several of these to the analysis of certain aspects of solar CR facilities in the following sections.

Models vary greatly in detail and assumptions. For the case of global problems, where in a sense the equations for the atmosphere are best defined, there is a whole heirarchy of models which are tailored to look at different aspects of the climate. These models vary greatly in computer running time, cost, naievity, completeness, etc. At the top of the heirarchy are the very detailed General Circulation Models (GCM's) which attempt to use the exact primitive equations of the atmosphere (or as close to exact as is feasible) and to integrate them out on a high speed computer. These are the most expensive global models to run. An additional difficulty of these models is the so-called "noise". The Navier-Stokes equation which is at the core of these models, possesses many unstable solutions. This instability reflects itself in the real atmosphere when two entirely different weather patterns can evolve from almost the same initial conditions, This same phenomena occurs with the GCM's. If one starts with slightly differing starting conditions and integrates the equations out in time, then a month later one will typically observe quite different weather patterns. When analyzing the impact of some new activity of man, such as building energy systems, a detailed analysis of the significance of the results is required. Usually this is done by running several control "experiments", starting with slightly different initial conditions and estimating the resulting

variation in parameters of interest. A run can then be made incorporating a change caused by some anthropogenic modification. The question is then whether the changes in the parameters of interest in going from the control case to the altered one are significant compared to the inherent variance of these parameters due to the model's instabilities. Often this exercise proves to be extremely expensive and the results inconclusive. This problem with GCM's will be difficult to overcome in the future because the unstable nature of these models simply reflects the properties of the real atmosphere. Despite these difficulties, a number of interesting and suggestive results have been obtained with these models. For example, model experiments suggest a close connection between the albedo of desert regions and precipitation. Experiments of different models confirm that increasing the albedo of a desert tends to decrease the rainfall, although the exact nature of the causative mechanism is a matter of dispute. Charney (1975), Ellsaesser et al. (1976), and an unpublished model run performed at NCAR, have confirmed this relationship. The effects of deforestation on altering the albedo, runoff rates, and evapotranspiration and consequently the climate have been studied by Potter et al. (1975). His results show a decrease in precipitation induced by deforestation. Other model experiments have dealt with such topics as changes in surface roughness, (Delsol, 1971), changes in sea surface temperatures, effects of localized waste heat sources (Washington, 1972), etc.

Mesoscale and microscale models are too numerous to list here. Their advantages over GCM's for looking at some problems are that they can treat small scale motion in much greater detail. However, the "rest of the world" is treated as an isolated system, thereby ignoring feedbacks from the region outside the model's domain, or else this region is treated in gross approximation. The advantages of these models is that they are much more sensitive to local or regional perturbations than are the GCM's and therefore more useful in analyzing the effects of limited deployment of some new technology.

The specific climatic effects of solar central receiver power plants are related to the dynamics of desert climates. This subject has been given recent attention in connection with the devastating drought in the Sahel region of Africa in 1973.

#### B. Desert Types

Deserts can be classified into three main types: rain shadow deserts, continental deserts, and deserts of subsidence. The rain shadow effect occurs when the desert is on the leeward side of a mountain range. Pure rainshadow deserts are quite rare as other, more subtle effects are usually present as well. However, the rain shadow effect certainly is an important factor in many deserts. Examples are most of the deserts of the American West, and the Patagonia of Argentina. Continental deserts form in land areas a large distance from a body of water. Most water simply precipitates out before reaching the area. Examples are the Gobi and Sinkiang deserts of China.

Many arid regions are associated with a descending atmosphere referred to as subsidence. This subsidence causes a decrease in relative humidity and can be accompanied by a decrease in cumulus convection. Both these factors tend to retard precipitation and cloud formation. In the case of rain shadows, subsidence results from topographical features. However, many other factors can affect subsidence. The most important of these is a global phenomena of the atmosphere; the so-called Hadley circulation cells. The ascending parts of the cells (one for each hemisphere) are responsible for the tropical (rainforest) areas of the globe; the descending part in the arid latitudes of the world's great subtropical deserts. Examples of deserts associated with the descending parts of the Hadley cells are the Sahara, Australia, the Kalahari of southern Africa, the Arabian peninsula, the Rajasthan and Thar deserts, and to some extent the deserts of North and South America.

#### C. Effects of Surface Albedo Modification

An elegant and detailed model relating surface albedo changes to changes in precipitation has been presented by Charney (1975). His ideas, roughly speaking, are as follows. Moist air rises in the inter-tropical convergence zones (the upward part of the Hadley cell), and moves poleward. The model includes a viscous boundary layer above the surface of the desert; and above this layer the flow is assumed geostrophic (Coriolis forces balance pressure forces). Inside the boundary layer the Coriolis force is assumed to balance the east-west friction force. Only radiative heat transfer is included in the model. Over the deserts, surface albedo is high (30 - 40%) relative to other parts of the

globe (except the ice caps). Charney ignores evaporation at the surface and assumes that the net short wave energy absorbed is equal to the net long wave energy radiated. In the model the atmosphere is transparent to short wave radiation, but absorbs long wave radiation because it is assumed to contain water vapor. Thus the atmosphere absorbs energy from the long wave radiation emitted from the surface. The atmosphere itself emits thermal radiation into space, and the temperature lapse rate is determined by the condition of radiative equilibrium. When the albedo of the surface increases, the equilibrium temperature of the atmosphere drops, due essentially to radiative cooling. As the air cools it descends, experiencing a decrease in relative humidity and also, Charney claims, less cumulous convection. Both of these effects tend to reduce precipitation. Charney has tested his ideas by running a GCM which showed a net increase in precipitation in going from an albedo of 35% to 14% for the Sahara. Charney argues that this effect establishes a bio-geophysical feedback mechanism between the atmosphere and the plants of arid locations. If albedo is increased, by reducing plant cover, rains decrease, plants die, and albedo is increased still further. The absence of vegetation and resulting high albedo help to maintain the desert. Charney argues that denudation of vegetation caused by overgrazing can thus reduce precipitation and cause a drought. He proposes this explanation for the recent Sahelian disaster. Although the details of Charney's explanation are a matter of some debate, the relationship between albedo and precipitation is consistent with present understanding of the atmosphere.

In the absence of extreme measures, the solar CR plant will alter the natural albedo in regions where they are placed. The Charney effect may be relevant. It is possible to pave the area between heliostats and paint it in order to produce no change in albedo, but this would add to the cost of the plant. The effects of CR plants on albedo have been considered by Weingart (1977). Parameters such as ground cover ratio, ratio of direct to diffuse radiation, and machine efficiency affect the amount to which albedo will be modified. In the section on models, the results of a global climate model (ZAM2) will be discussed regarding this issue. Other parameters, such as evaporation rates, could also be modified.

A complication which can affect the climatic modification of CR plants is the possibility that synthetic fuels will be produced at the plant site and transported large distances to energy markets such as Europe or Japan. In this case, the effect on climate cannot be treated as a simple albedo modification. For the models that we have used to study albedo modification, the grid size is so large that transportation of fuels could be safely ignored.

#### D. Effects of aerosols.

Construction of solar plants can cause dust to enter the atmosphere during the construction phase; during the operation phase if ground cover is destroyed; and by the induced additional off-road vehicle activity. The dust would interfere with the operation of the plant both by reducing the incident solar radiation and by reducing the reflectivity of the mirrors. Hence some corrective measures (e.g., paving) may well take place. To the extent that solar plants do lead to large amounts of dust in the atmosphere, there are possible climatic

implications. In general particulates affect the interaction of the atmosphere with both long and short wave radiation. Their presence will affect the amount of radiation reflected back into space and thereby the planetary albedo. They will also modify the absorbtive properties of the atmosphere in the infra-red. In addition, they can affect nucleation and thereby cloud and precipitation amounts.

It has been suggested by Bryson (1967) that the large amounts of dust in the atmosphere of India's Rajasthan desert is important in sustaining the desert environment. He argues that the presence of aerosols causes cooling of the atmosphere by reflecting more short wave radiation back into space than would otherwise be the case. This cooling again results in subsidence and aridity. He has proposed this mechanism as an explanation of the encroachment of the Rajasthan in historic times. To the extent that construction of solar central receiver plants and associated off-road vehicles cause large amounts of dust to enter the atmosphere, Bryson's effect may tend to make the desert more arid. Since the magnitude of the dust-related effects are not clear, and the amount of dust that will be attributable (either directly or indirectly) to the solar plants is not presently known, the importance of the dust cannot be quantified.

#### E. Effects on Evaporation Rates.

Central receiver plants could affect evaporation rates in the deserts in several ways. First, if wet cooling devices are used then an amount of water directly proportional to the output of the plant would be evaporated. Espey, Huston, and Associates (1974) have provided data on evaporation rates for different types of cooling device by region.



For example, for mechanical draft cooling towers they list a water consumption rate in the Lower Colorado water region of .76 pounds per thousand Btu's rejected as an annual average.

A major factor influencing evaporation rates would be the population increases in the vicinity of the central receiver plants. This additional population would require water for life, irrigation, and recreation, which would increase the amount of vapor introduced into the atmosphere in the region. This population increase would probably be the most important factor since wet cooling devices will not likely be used.

In the event that evaporative cooling devices are used with solar plants, they may cause fog or clouds. The details would depend on the type of cooling. For example, Currier et al. (1974) have taken data of fogging around the cooling pond at the 4 corners power plant. Their results suggest that fogging is correlated with the parameter  $I = \Delta t / (e_s - e_a)$ , where  $\Delta t$  is the difference between water temperature and ambient air temperature,  $e_s$  is vapor pressure of saturated air at ambient air temperature, and  $e_a$  is ambient air vapor pressure. The larger  $I$ , the more likely the occurrence of fog. Usually some condensation occurred for  $I > 20^\circ\text{F}/\text{mb}$ . For other types of cooling devices this index might not be suitable, but in any event we can expect fogging to become less likely with a decrease in relative humidity. Perhaps the best way to study this potential problem would be to identify a list of existing microscale models which incorporate condensation and apply them to the solar plant site. In addition to fogging, evaporative cooling devices will introduce toxic or undesirable substances into the

atmosphere depending on the mineral content of the water used for cooling. Generally speaking, due to the low relative humidity of the desert atmosphere, fogging and cloud formation are not likely to be major problems except perhaps at dusk, dawn, and night.

F. The Heliostat Canopy

The heliostat canopy will partially shade the ground, which will thus experience reduced evaporation rates. This reduced evaporation will probably be most noticeable shortly after a storm, when soil-held water usually evaporates rather quickly. Evaporation of dew will also be retarded. Dew can be an important source of moisture in deserts. Monteith (1957) and Baier (1966) have given reviews of the state of knowledge of dew formation in arid regions. This moisture may support some extra vegetation. In addition, more condensation may occur at night in the heliostat field because of the extra area provided by the heliostat surfaces. The heliostats thus will lead to a larger soil moisture content assuming that the ground is not paved.

G. Effects on Turbulent Transfer Rates

Generally speaking, the effects of turbulence in the lower atmosphere are very important in determining the microclimatology of a given location. Such quantities as diurnal temperature variation, wind profile, buoyant plume rise rates, evaporation rates, diffusion rates, etc. are strongly influenced by the turbulent properties of the lower atmosphere. Reviews of results on turbulence may be found in Priestly (1959), Csanady (1973), and Sutton (1953).

Turbulence is only partially understood at this time. At present most studies attempt to phenomenologically parametrize the effects of turbulence in terms of diffusion coefficients. A number of parametrizations have been suggested, and the more important ones are discussed in the above mentioned reviews of the subject. Diffusion rates for such quantities as temperature, momentum, humidity, etc. tend to increase dramatically when the atmosphere enters a turbulent regime, and to further increase as the turbulence becomes more energetic.

A simple example is the vertical transport of heat which is standardly parametrized in the simplest form by a single constant  $K_H$  by the equation

$$\frac{\partial \theta}{\partial t} = K_H \frac{\partial^2 \theta}{\partial z^2}, \quad \theta = \text{potential temperature.} \quad (1.)$$

$K_H$  depends on atmospheric conditions, and in particular on the state of atmospheric turbulence. It is called the virtual coefficient of conduction. No rigorous theory of  $K_H$  exists at the present time. Priestley presents a table of measured values of  $K_H$  for different atmospheric conditions. According to this table,  $K_H$  can vary from a low of  $.2 \text{ cm}^2/\text{sec}$  for still air to about  $10^7 \text{ cm}^2/\text{sec}$  for very unstable stirred air. Thus the effects of eddy diffusion can vary over eight orders of magnitude, depending on the state of the atmosphere. A heliostat field on a desert flat would undoubtedly increase turbulence and therefore  $K_H$ . This would in turn modify the diurnal temperature variation. Under normal conditions, if  $K_H$  is increased, then the atmosphere will respond more quickly to changes in surface temperatures. In the case of the heliostat field, the properties of the surface would

be modified, and the turbulence may not penetrate beneath the heliostat canopy. This complicates the application of equation 1 to this process. It is the authors' opinion that an increase in  $K_H$  due to the presence of the heliostats is probably not (to first order at least) of any great concern to environmentalists.

#### H. Effects on the Wind Profile

The mean horizontal wind profile is observed to be a function of the roughness of the terrain over which the wind is passing. It is a standard to parametrize the mean horizontal velocity as a function of altitude as (Sellers, 1965)

$$U = U^* / K \ln(Z/Z_0) \quad (2.)$$

where  $K$  is approximately 0.4 (the Von Karman constant),  $U^*$  is the friction velocity, and  $z_0$  is the roughness length. Sellers presents a table of  $z_0$  for different terrain. For a smooth desert he gives a value of  $z_0 = .03$  cm. For a citrus forest he gives  $z_0 = 198$  cm. The citrus forest is the closest analogy to a heliostat field in the table. The effect of the heliostat field would then be to reduce the mean winds somewhat above the field, according to Eq. 2, by modifying  $z_0$ .

#### I. A Model of Convection about a Central Receiver Plant

Convection caused by the cooling towers of a CR plant could be of environmental importance because convective winds might lift dust and fine particles into the atmosphere. Our results suggest that this will not be a problem except very near to the tower. We shall present expressions for radial and vertical mean velocities as functions of altitude and radius about a cooling tower, and for the case of a neutral

atmosphere. Convective velocities would probably be greater for unstable atmospheres. We consider only dry cooling towers. Wet cooling towers ought to be modelled as well, but complications arise because of condensation phenomena, so that more elaborate techniques must be used. The model used here is a gaussian plume model developed by Priestley and Ball (Priestley, 1955 and 1959; Priestley and Ball, 1955), which will be denoted by PB. More elaborate treatments may be found in Stern's books (1968) on air pollution. A somewhat old but still useful review of the subject is given by Sutton (1953).

Turbulent entrainment can be an important factor in determining mean convective velocities for a cooling tower. In this case, the Navier-Stokes equations cannot be treated exactly, and either computer simulation must be used or some approximation made. Both of these approaches have drawbacks. Computer simulations of turbulence can be very expensive, especially if small scale eddies are to be modelled accurately. On the other hand most approximations made to treat turbulent effects analytically are ad hoc and theoretically unjustified. The PB model is an example of the latter case. The assumptions in this model are based on empirical evidence, and are commonly used.

Consider a cylindrically symmetric heat source on a horizontal surface. For simplicity, assume that the environmental temperature is a function only of altitude, and there is no wind. Following PB, we write

$$\frac{\partial}{\partial z} (rw\rho) + \frac{\partial}{\partial r} (rup) = 0 \quad (1.)$$

$$\frac{\partial}{\partial z} (rw^2\rho) + \frac{\partial}{\partial r} (ruw\rho) = r \frac{\theta'}{\theta_e} \rho g + \frac{\partial}{\partial r} (r\tau) \quad (2.)$$

which are the equations of motion and conservation respectively, for a viscous fluid in the hydrostatic approximation. The cylindrical coordinates  $Z$  and  $r$  denote height and distance from the centerline of the cooling tower respectively. These equations are coupled to an equation for energy conservation

$$\frac{\partial}{\partial Z} (rw\theta\rho) + \frac{\partial}{\partial r} (ru\theta\rho) = - \frac{1}{C_p} \frac{\partial}{\partial r} (rF) , \quad (3.)$$

where

$w$  = vertical velocity

$u$  = radial velocity

$\rho$  = density

$\theta$  = potential temperature

$\theta_e$  = environmental potential temperature

$\theta'$  = excess potential temperature ( $\theta - \theta_e$ )

$\tau$  = vertical turbulent shearing stress

$F$  = radial (potential) turbulent heat flux

$C_p$  = specific heat of air (taken as a constant).

All the quantities are mean values averaged over turbulent fluctuations.

PB assume the following form for a solution:

$$\begin{aligned} w/w_m &= f(r/R) , \quad \theta'/\theta'_m = h(r/R) , \\ \tau/1/2\rho w_m^2 &= j\left(\frac{r}{R}\right) , \end{aligned} \quad (4.)$$

where the subscript  $m$  denotes the value on the axis of symmetry.  $R$  is an unknown function of  $z$  and  $j$  another unknown function of  $r/R$ .  $w_m$  and  $\theta'_m$  depend only on height  $z$ . These forms are not an exact solution, but do conform to an intuitive picture of a rising plume. These assumptions have also been approximately verified experimentally, and they are standard in all gaussian plume models.

For the special case of neutral conditions ( $\theta_e$  a constant independent of  $z$ ) the equations are solvable with these approximations. PB find in this case

$$R^2 W_m \theta'_m = \text{constant} = A. \quad (5.)$$

Making a gaussian approximation,

$$f = h = \exp\left(-\frac{r^2}{2R^2}\right),$$

they find

$$W_m = \left\{ \frac{3Ag}{2\theta_e c^2 Z} + \frac{B}{Z^3} \right\}^{1/3}, \quad (6.)$$

$$\theta'_m = \frac{A}{c^2 Z^2} \left\{ \frac{3Ag}{2\theta_e c^2 Z} + \frac{B}{Z^3} \right\}^{-1/3}, \quad (7.)$$

$$A = Q/\pi \rho C_p, \quad (8.)$$

where  $Q$  is the source strength.

$$R = cZ. \quad (9.)$$

The parameters  $A$ ,  $B$ , and  $c$  are constants of integration. The point  $z = 0$ ,  $r = 0$  has been chosen to be the concurrent point of the cone shaped plume.

For our purposes we shall ignore the terms containing  $B$  in these expressions. These terms fall off fast with altitude and are difficult to determine.

An expression for the radial velocity  $u$  may be obtained from the equation of continuity (1), which can be integrated to yield

$$u(r, Z) = -\frac{\partial}{\partial Z} W_m R^2 \left[ 1 - e^{-\frac{r^2}{2R^2}} \right]. \quad (10.)$$

Substituting into this expression the forms for  $w_m$  and  $R$ , and taking  $B = 0$ , we find

$$u = - \frac{c^2 w_m z}{r} \frac{5}{3} \left( 1 - e^{-\frac{r^2}{2R^2}} \right) + w_m \frac{r}{z} e^{-\frac{r^2}{2R^2}}, \quad (11.)$$

$$w_m = \left( \frac{3Ag}{2\theta_e c^2 z} \right)^{1/3} \quad (12.)$$

$$\theta' = \frac{A}{c^2 z^2} \left( \frac{3Ag}{2\theta_e c^2 z} \right) \quad (13.)$$

$$R = cz \quad (14.)$$

$$A = Q/\pi\rho C_p \quad (15.)$$

$$R^2 w_m \theta' = A. \quad (16.)$$

We next apply these equations to a solar thermal plant to analyze convection caused by its dry cooling towers.

Consider a 100 MW<sub>e</sub> intermediate load power plant using the central receiver design. The waste heat rejected at the tower will be about 200 MW<sub>t</sub>. The air at the mouth of the tower might be about 66°C (150°F), a typical condensing temperature for a steam system. This model does not give an accurate depiction of convection near the ground because it does not meet the condition that the vertical velocity vanish at the surface, and also the heliostats will modify the velocity field near the ground. In order to get an idea about how large the velocities might conceivably be, we shall consider a height level with the tower top. Let z<sub>0</sub> be the coordinate of the top of the tower. From equation 14, we see that the point z = 0, r = 0 is the apex of the cone shaped volume. This point will not in general be level with the surface, therefore z<sub>0</sub> is not the height above the ground of the top of the tower, but the height above this apex point. At z = z<sub>0</sub> we must have

$$R = cz_0 = R_0, \quad (17.)$$

where R<sub>0</sub> is the radius of the tower.



Denote the total heat per unit time rejected by the tower by  $Q$ .  $W_m$  at  $z = z_0$  is then obtained from eqs. 5 and 8,

$$W_m(z_0) = Q / (\pi R_0^2 \rho C_p \theta'_0) \quad (18.)$$

$$= \frac{Q}{\pi R_0^2 \theta'_0} \times 8.5 \times 10^{-5} \frac{\text{K}^\circ \text{cm}^3}{\text{erg}} \quad (19.)$$

Equation 11 then gives  $u$  at this height, once  $c$  is known. For  $r \gg R$ , the

$$u \approx -\frac{5}{3} \frac{c^2 W_m z}{r} \quad (20.)$$

The parameter  $c$  may be solved for in terms of known quantities;

$$c = \theta'_0 \sqrt[3]{\frac{R_0^5}{A} \frac{3}{2} \frac{g}{\theta'_e}} = \frac{3}{2} \frac{\theta'_0}{\theta'_e} \frac{R_0 g}{W_m} \quad (21.)$$

where

$$\theta'_0 = \theta' \Big|_{r=0, z=z_0} \quad (22.)$$

Typical numbers for a solar cooling tower in an arid location might be

$$Q = 200 \text{ MW}_t \quad (23.)$$

$$\theta'_e = 305^\circ \text{K} \quad (24.)$$

$$\theta'_0 = 35^\circ \text{K} \quad (25.)$$

$$R_0 = 16 \text{ m}, \quad (26.)$$

$w$  and  $u$  are then determined in terms of these. We find

$$w_m(z_0) = 6 \text{ m/s} = 22 \text{ km/hr.} \quad (27.)$$

This is the velocity of the air at the mouth of the cooling tower. We find a value for  $c$  of

$$c = .75 \quad (28.)$$

The  $z$  coordinate of the tower mouth,  $z_0$ , is equal to

$$z_0 = R_0 / c = 21.3 \text{ m.} \quad (29.)$$

At this height,  $u(r)$  is given by (for  $r \gg R_0$ )

$$u(r, z_0) = - \frac{120m}{r} \cdot \frac{m}{s}, \quad (30.)$$

so that at a distance of 50 meters from the tower centerline

$$u(r=50m, z_0) = 8.6 \text{ km/hr} \quad (31.)$$

Our calculation was performed with the assumption of a neutral atmosphere. For unstable conditions ( $\theta'_e < 0$ ) we would expect the convective currents to be larger, and for stable conditions ( $\theta'_e > 0$ ), we would expect them to be smaller. The above velocity of 8.6 km/hr does not seem to be large enough to cause concern about increased erosion, and this velocity would occur only in the vicinity of the tower. Based on this model, we may say that convection does not appear to cause environmental or practical problems except perhaps in the case of an unstable environmental atmosphere.

## J. A Global Scenario with Some Model Applications

### 1. The scenario

Models of the entire earth's atmosphere are useful for studying climate modification on a global or regional level. In order to use such models, a scenario of global deployment of CRs is necessary. Any such scenario can give but a crude estimate as to the numbers and location of the plants, but the results of such models could give a semi-quantitative idea of the effects of this technology on the climate. The scenario developed here could also be used for other desert based systems such as photovoltaics or parabolic trough collectors.

The maximal scenario presented here is considered to be an overestimate of the number of CR plants which could ever reasonably be built. The reason for this overestimate is that if the postulated level of construction does not lead to dramatic climate effects in existing models, then it is unlikely that a smaller scenario would. Thus, the intent is to bound the effects on climate.

Present world population has passed 4 billion. By the year 2000 it could reach 6.5 billion. The 21st century may well end with a world of 10 billion people. Desert based solar systems could provide energy to this many people, and we shall assume this population in this scenario.

Present energy consumption in the U.S. is about  $10 \text{ kW}_t$  per person. Most of this is currently in the form of fossil fuels. If fuels are produced synthetically at a CR plant, then the efficiency for conversion of electricity into chemical energy is high, close to 90%. Thus in order to produce  $10 \text{ kW}_t$  of synthetic fuels would require about  $10 \text{ kW}_e$  of base load power (or approximately  $30 \text{ kW}_t$ ). We shall assume then a world population of 10 billion with a per capita energy use of  $10 \text{ kW}_e$ .

In order to generate  $100 \text{ MW}_e$  of base load power, about 1.5 to  $2.0 \text{ km}^2$  of reflector surface would be required with present designs. We will use the upper value. In addition to the effects of the actual facilities, support personnel and industry attracted to the region will occupy land. The area affected by the support personnel could easily be  $1 \text{ km}^2$  for a  $100 \text{ MW}_e$  plant. We shall assume this figure.  $10^6$  such plants would be needed to meet the energy needs described above, yielding a total of  $2 \times 10^6 \text{ km}^2$  of mirror area, and about  $1 \times 10^6 \text{ km}^2$  for

support personnel. The ground cover ratio for the plants will be taken to be 1/3, so that the total area needed for the plants would be about  $6 \times 10^6 \text{ km}^2$ .

In estimating the effects on albedo of the above scenario, we shall make the following assumptions.

- a. An area equal to the total mirror area of the plants becomes completely black.
- b. An area equal to the  $1 \times 10^6 \text{ km}^2$  attributed to the support personnel becomes perfectly black.

Thus, a total of  $3 \times 10^6 \text{ km}^2$  is darkened. For convenience, we shall assume that this darkened area is spread out over an area of  $9 \times 10^6 \text{ km}^2$ , corresponding to a ground cover ratio of 1/3 for support personnel land also. The important point is the amount of land darkened. With the assumptions the new albedo ( $\alpha$ ) for the  $9 \times 10^6 \text{ km}^2$  of land would be

$$\alpha \approx 2/3 \alpha_N \quad (1.)$$

where  $\alpha_N$  is the natural albedo.

In order to complete this scenario, it must be decided how this land is to be distributed throughout the deserts of the world. Table XII shows our estimate, for this scenario, of how the solar energy production might be distributed throughout the world. Figure V-1 and Table XIII present these estimates in more detail by specific location with areas and geographic boundaries. The information for running a zonally averaged model is presented in Table XIV, which shows areas covered in this scenario by  $10^\circ$  latitude bands. A considerable number of solar plants were placed in North America because of the relatively suitable desert areas and the present and expected future energy needs of the U.S. The Patagonia of Argentina has potential because of the fairly

Table XII. Mirror and Land Areas for Scenario by Rough Location.

---

Region	Percent	Total Mirror Area (Km <sup>2</sup> )	Land Area (Km <sup>2</sup> )
N. America	15	4.5×10 <sup>5</sup>	13.5×10 <sup>5</sup>
S. America	10	3.0×10 <sup>5</sup>	9 ×10 <sup>5</sup>
Europe	<5	1.5×10 <sup>5</sup>	4.5×10 <sup>5</sup>
Sahara	15	4.5×10 <sup>5</sup>	13.5×10 <sup>5</sup>
Arab. Penin.	10	3.0×10 <sup>5</sup>	9 ×10 <sup>5</sup>
India	15	4.5×10 <sup>5</sup>	13.5×10 <sup>5</sup>
China	15	4.5×10 <sup>5</sup>	13.5×10 <sup>5</sup>
Australia	5	1.5×10 <sup>5</sup>	4.5×10 <sup>5</sup>
S. Africa	5	1.5×10 <sup>5</sup>	4.5×10 <sup>5</sup>
USSR	5	1.5×10 <sup>5</sup>	4.5×10 <sup>5</sup>
Total	100	3. ×10 <sup>6</sup>	9 ×10 <sup>6</sup>

---

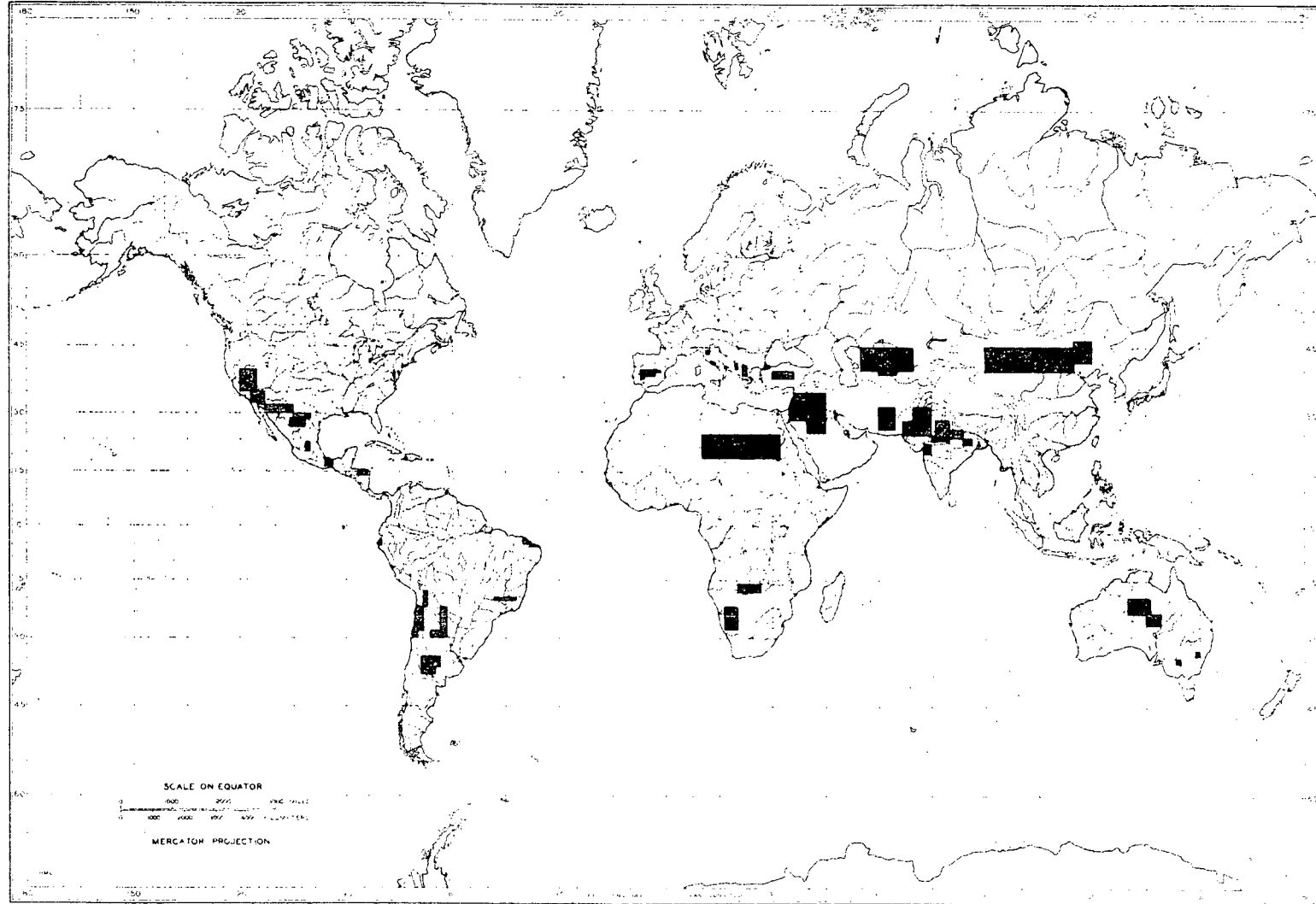

GOODE BASE MAP SERIES  
DEPARTMENT OF GEOGRAPHY  
THE UNIVERSITY OF CHICAGO  
HENRY M. LEPPARD, EDITOR

Prepared by Henry M. Leppard  
© 1961 by The University of Chicago  
XBL 775-8794

Fig. V-1 Map Showing Distribution of Solar Plants in the Global Scenario.

Table XIII. Latitude-Longitude Limits for Solar Land in Global Scenario.

LATITUDE LIMIT	LATITUDE LIMIT	LONGITUDE LIMIT	LONGITUDE LIMIT	AREA(SQ.KM)
18.00000	25.00000	-10.00000	-32.00000	1774405.83988
35.00000	40.00000	115.00000	120.00000	245693.37541
32.00000	35.00000	110.00000	115.00000	154978.97831
32.00000	35.00000	115.00000	117.00000	61991.59132
28.00000	35.00000	100.00000	105.00000	369562.78866
20.00000	22.00000	100.00000	102.00000	46271.56039
30.00000	32.00000	105.00000	113.00000	169937.04483
26.00000	28.00000	102.00000	104.00000	44161.45035
16.00000	18.00000	94.00000	96.00000	47397.85684
14.00000	16.00000	84.00000	87.00000	71812.06558
26.00000	28.00000	104.00000	106.00000	44161.45035
30.00000	35.00000	-35.00000	-40.00000	261189.63132
30.00000	35.00000	-40.00000	-45.00000	261189.63132
25.00000	30.00000	-40.00000	-45.00000	274698.07979
28.00000	30.00000	-35.00000	-40.00000	108373.15734
25.00000	32.00000	-70.00000	-75.00000	380908.73281
25.00000	28.00000	-67.00000	-70.00000	99794.95347
26.00000	32.00000	-60.00000	-65.00000	324987.43624
23.00000	25.00000	-70.00000	-80.00000	226392.78979
22.00000	24.00000	-84.00000	-86.00000	45623.48971
24.00000	26.00000	-80.00000	-84.00000	89839.66787
26.00000	28.00000	-76.00000	-82.00000	132484.35106
20.00000	22.00000	-73.00000	-75.00000	46271.56039
40.00000	45.00000	-90.00000	-115.00000	1141636.23855
42.00000	46.00000	-115.00000	-120.00000	178238.11161
40.00000	45.00000	-55.00000	-70.00000	684981.74313
39.00000	40.00000	-60.00000	-65.00000	47807.40490
38.00000	40.00000	3.00000	6.00000	57777.18941
37.00000	40.00000	6.00000	7.00000	29089.79250
39.00000	40.00000	2.00000	3.00000	9561.48098
43.00000	44.00000	-11.00000	-12.00000	8988.37892
41.00000	41.50000	-14.00000	-15.00000	4658.20490
40.50000	41.00000	-16.00000	-17.00000	4693.67654
40.00000	42.00000	-19.50000	-20.00000	9351.52536
39.00000	40.00000	-22.00000	-23.00000	9561.48098
40.50000	41.00000	-22.00000	-23.00000	4693.67654
38.00000	40.00000	-32.00000	-36.00000	77036.25255
38.00000	40.00000	-30.00000	-32.00000	38518.12628
41.00000	42.00000	-28.00000	-29.00000	9280.58342
-22.00000	-28.00000	-16.00000	-20.00000	269409.54801
-16.00000	-18.00000	-18.00000	-26.00000	189591.42734
-23.00000	-27.00000	-135.00000	-139.00000	179651.96976
-19.00000	-23.00000	-130.00000	-136.00000	277587.07812
-33.00000	-34.00000	-149.00000	-150.00000	10332.98106
-35.00000	-36.00000	-144.00000	-145.00000	10088.00054
-28.00000	-30.00000	70.00000	72.00000	43349.26294
-24.00000	-28.00000	68.00000	71.00000	133621.92643
-22.00000	-24.00000	68.00000	70.00000	45623.48971
-3.00000	-6.00000	38.00000	40.00000	74111.43159
-5.00000	-6.00000	35.00000	38.00000	37002.93198
-20.00000	-21.00000	42.00000	48.00000	69639.84996
-4.00000	-6.00000	80.00000	81.00000	24687.47022
-18.00000	-22.00000	67.00000	68.00000	46567.40839
-22.00000	-30.00000	62.00000	64.00000	178054.03694
-28.00000	-30.00000	64.00000	66.00000	43349.26294
-26.00000	-28.00000	64.00000	65.00000	22080.72518
-34.00000	-38.00000	65.00000	69.00000	160366.63234
-34.00000	-36.00000	64.00000	65.00000	20300.04668

Table XIV. Solar Land Areas by Zone for the Global Scenario as Used by ZAM2.

Zone	Zonal Area (Km <sup>2</sup> )	Solar Area (Km <sup>2</sup> )	<u>Solar Area</u> <u>Zonal Area</u>	<u>Solar Area</u> <u>Zonal Land Area</u>
-85 to -75	7,724,694.	0.	0.0	0.0
-75 to -65	15,223,838.	0.	0.0	0.0
-65 to -55	22,260,587.	0.	0.0	0.0
-55 to -45	28,621,214.	0.	0.0	0.0
-45 to -35	34,112,527.	138,350	.0041	.029
-35 to -25	38,567,738.	599,849.	.0156	.061
-25 to -15	41,851,529.	961,414.	.0230	.061
-15 to -5	43,864,162.	71,954.	.0016	.005
-5 to 5	44,544,505.	63,848.	.0014	.003
5 to 15	43,871,895.	34,860.	.0008	.002
15 to 25	41,866,762.	2,254,935.	.0539	.127
25 to 35	38,590,007.	2,738,772.	.0710	.162
35 to 45	34,141,155.	2,511,375	.0736	.146
45 to 55	28,655,332.	58,059.	.0020	.003
55 to 65	22,299,159.	0.	0.0	0.0
65 to 75	15,265,692.	0.	0.0	0.0
75 to 85	7,768,560.	0.	0.0	0.0



good solar radiation levels and the accessible markets of South America. Other sites in South America include parts of Chile, Bolivia, Peru, and Brazil. Suitable locations in Europe are limited to a few areas in Spain, Italy, Yugoslavia, and Greece. Turkey has a high potential. The Sahara and Arabian Peninsula could supply huge amounts of energy, provided the problem of labor and distribution could be overcome. India's Rajasthan and Pakistan's Thar deserts are suitable, although dust may be a problem in India (Bryson, 1967). In Africa, the Kalahari desert could probably meet the energy needs of the entire continent. Australia has vast potential, but is distant from accessible markets and so probably won't be a major producer. China's Gobi and Sinkiang deserts, although rather far north, could be major producers because of the vast labor pool of this country. Japan could be a major market for energy. The arid lands east of the Caspian sea in the USSR have potential, although they also are at a fairly high latitude.

## 2. Global radiation temperature change

Global and massive use of CR plants will alter the heat balance of the earth to some extent. While GCM's (see above) are required for a detailed analysis of this altered heat balance, a simple "zero-dimensional" black body model can serve to provide an estimate. In this spirit, the radiation temperature of the earth is defined by the following equation

$$S\pi R_e^2(1-\bar{\alpha}) = \epsilon\sigma 4\pi R_e^2 T_R^4, \quad (1.)$$

where  $\sigma$  is the Steffan-Boltzman constant,  $T_R$  the radiation temperature,  $\epsilon$  the average emissivity of the earth,  $\bar{\alpha}$  the average planetary albedo (about 36%, Sellers, 1965),  $S$  the solar constant ( $1.4 \text{ kW/m}^2$ ), and  $R_e$  the radius of the earth (the value for  $\epsilon$  will eventually drop out. The left hand side of eq. 2 is the net short wave radiation which is absorbed by the earth per unit time.

Let us first look at this equation applied to the scenario, but ignore the land attributed to support personnel. Denote the total mirror area by  $A_R$ . As a time average, only half the mirror area will be tracking the sun, the other half being on the dark side of the earth. Let us take the tracking mirrors to be normal to the sun. This approximation overestimates the effect, but probably not more than 50%. Thus a cross sectional area of  $1/2 A_R$ , located in the deserts of the world, becomes completely absorbing for direct radiation. If we ignore attenuation of short wave radiation over the deserts, the earth's net radiation gain over the natural case is

$$\text{Net radiation gain} = 1/2 S A_R (1 - (1 - \alpha_D)), \quad (2.)$$

where  $\alpha_D$  is the natural albedo of the desert. Typical values of  $\alpha_D$  range from .25 to .4. The temperature change is then determined by the following equation (for relatively small changes)

$$\begin{aligned} \text{Net radiation gain} &= \delta \{ \epsilon \sigma 4\pi R_e^2 T_R^4 \} \\ &= 4\pi \epsilon \sigma R_e^2 T_R^4 \frac{4\delta T_R}{T_R} \end{aligned} \quad (3.)$$

Using eq. 1, we find

$$\delta T_R = \frac{1}{8} \frac{\alpha_D}{1 - \bar{\alpha}} \frac{A_R}{\pi R_e^2} T_R. \quad (4.)$$

Using a value of .3 for  $\alpha_D$  and 285°K for  $T_R$ , we find

$$\delta T_R = .25^\circ\text{K} \quad (5.)$$

Figure V-2 shows the change in temperature as a function of energy generated versus different values for  $\alpha_D$ .

Within the context of this simple model, the use of nuclear power plants or fossil fuel plants to generate this same amount of energy would lead to about three times as large a temperature increase, because about three times as much waste heat would be liberated terrestrially. The argument for this is as follows. If we generate a certain amount of electricity at a nuclear plant or fossil fuel plant, the efficiency of generation is about 33%. Thus the energy content of the fuels burned is three times the electric generated. All of this energy eventually goes to heating up the planet. For the CR plants, the case is different. The net heat gained, even with the extreme assumptions used here, is still approximately equal to the electric energy generated. This approximate quality is a coincidence which depends on the desert albedo having a value of about 1/3. Since temperature shifts in the model are proportional to the net heat gain, nuclear power or fossil fuel would increase  $T_R$  by about .75°K for our postulated energy demand.

Including the effects of the support personnel, which are more speculative, would modify the CR calculation and lead to about a 50% larger change in temperature. Thus a change of .37°K is conceivable. This would only be about a factor of two better than the nuclear or fossil cases.

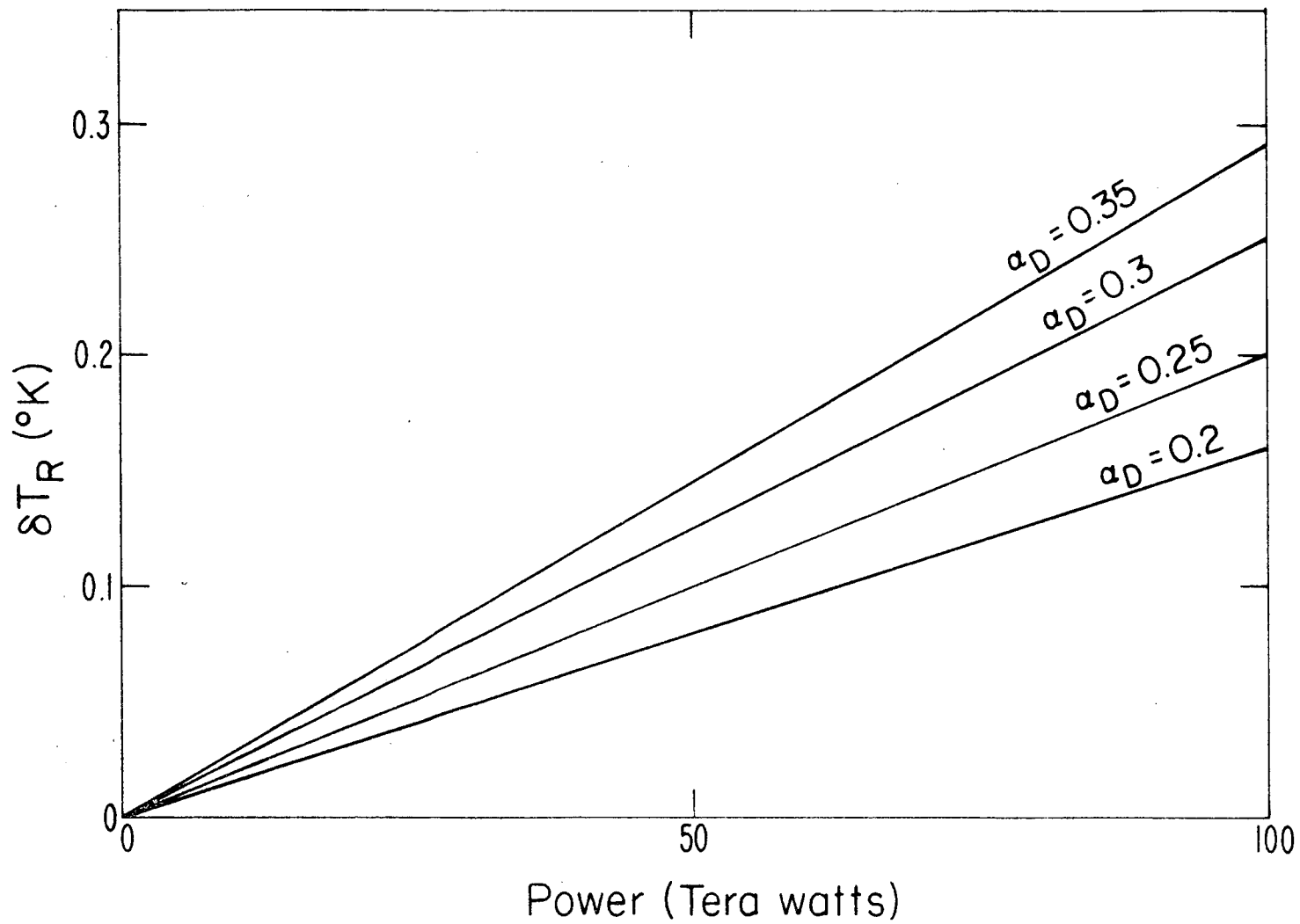

XBL 775-988

Fig. V-2 Radiation Temperature Change as a Function of Installed Capacity of Central Receiver Plants for Different Desert Albedos.

The value of this calculation is limited in that it doesn't address questions of more practical importance; such as will precipitation rates, circulation patterns, temperature patterns, etc., be affected by this level of energy use. An increase of  $.25^{\circ}\text{K}$  to  $.37^{\circ}\text{K}$  is not as large as is attributed to such natural phenomena as ice ages or periods of extreme vulcanicity. However, the temperature change in some geographic locations might be much more dramatic, and the model could easily be off by a factor of two in predicting global average temperature change. In order to pursue this question further, the following model was run at Lawrence Livermore Laboratory.

### 3. Results of ZAM2

ZAM2 is a two dimensional, zonally averaged model developed at the Lawrence Berkeley Laboratory (MacCracken and Luther, 1975). By zonally averaged is meant that the model averages over longitude. It looks at dependence on latitude (in  $10^{\circ}$  bands) and altitude. The above scenario (including land devoted to support personnel) was input into this model. The model was run by Potter and MacCracken (1977) who were provided the data for the scenario in the form of table XIV by the authors. Their results show the following:

- a. Temperatures generally increase, with the exception of a few isolated and anomalous points.
- b. Temperature increases are largest in the polar regions because of the ice-albedo feedback and water vapor feedback.
- c. Precipitation increased slightly at most latitudes.

Figure V-3 shows the zonally averaged surface temperature change as a function of latitude. Figure V-4 shows the difference in precipitation caused by the operation of the solar plants, also zonally averaged.

The global temperature changes shown in Figure V-3 are consistent with the results of the zero dimensional model of the previous section. These changes are small relative to some natural changes even for this massive scenario. Because of this, the model probably responds approximately linearly to increases in the number of solar plants. A smaller, more realistic scenario would have proportionally smaller effects than the one considered here. For example, if only 1/10 as many plants were built, but were distributed roughly as was assumed for this scenario, then the temperature and precipitation changes shown Figures V-3 and V-4 would be only 1/10 as large.

The changes that ZAM2 predicts are sufficiently small that it is questionable whether a 3-D GCM would be sensitive to them. There is one possibility, however, that may merit further consideration. The zonally-averaged approach of ZAM2 will "smear out" regional effects. If such regional effects are significant, then they might be discernable in a 3-D GCM.

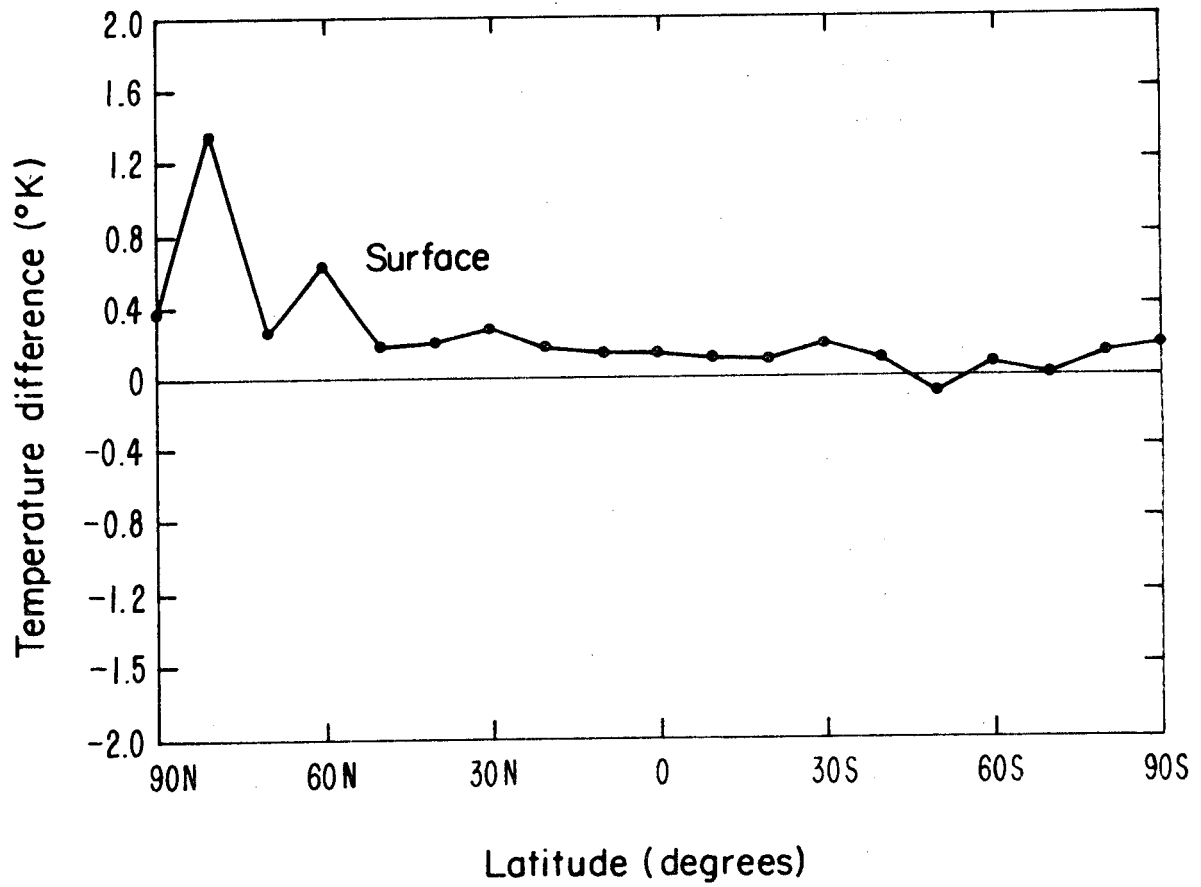

XBL 775-987

Fig. V-3 Temperature Difference by Latitude at Surface Resulting from Global Scenario in ZAM2.

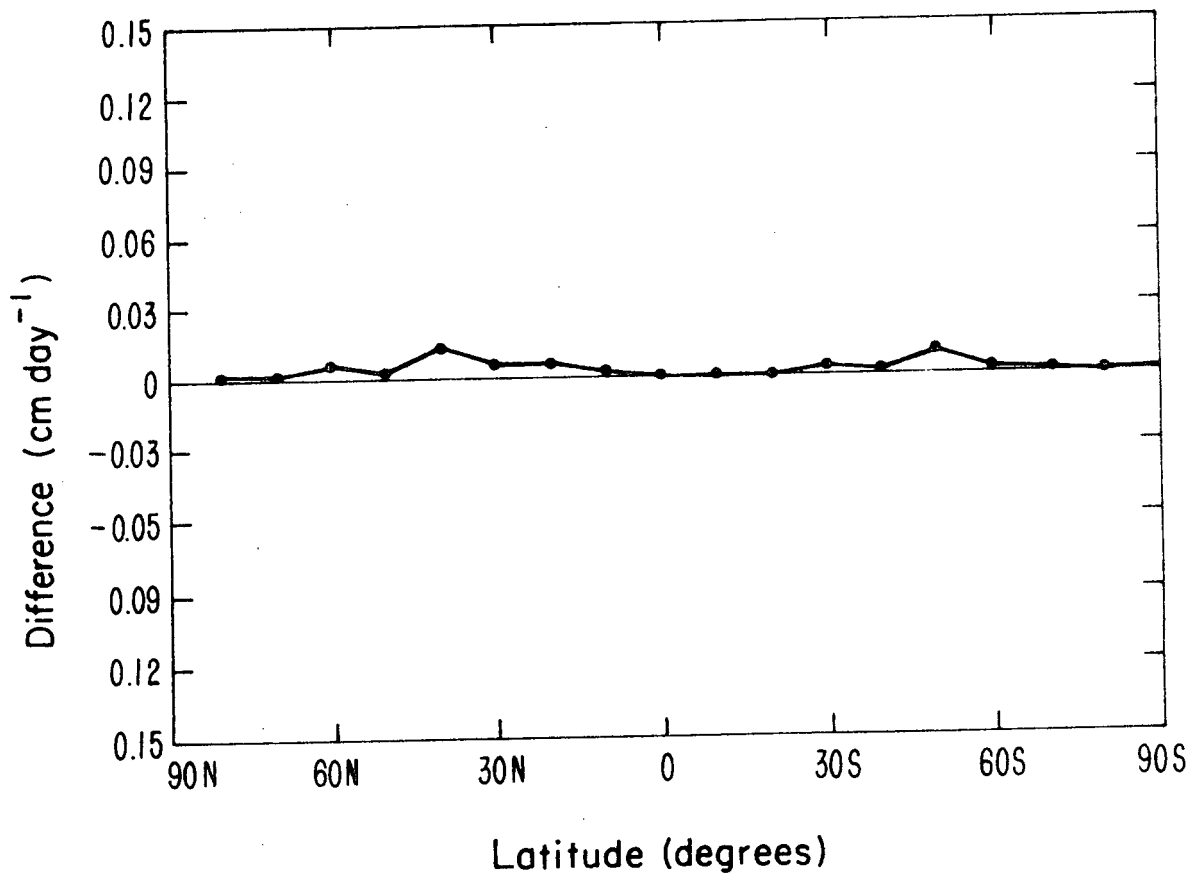

XBL 775-986

Fig. V-4 Precipitation Difference by Latitude Resulting from Global Scenario in ZAM2.



## VI. Conclusion

In this paper a number of effects which the central receiver power plant could have on the environment and on American society have been examined. After a brief review of various technical designs for CRs, the results of various scenarios of implementation on industrial output, employment, pollution, desert ecology, water and land requirements, and climate were modeled or discussed. All of the models used were of necessity only approximations to complex systems such as the U.S economy or the atmosphere. The results of this study can be used as input into studies concerned with future energy supply in the U.S. Such studies are vital in determining future research trends, subsidies, and demonstration programs funded by the government which will shape the future of energy supply.

Future costs of central receivers will strongly influence their market penetration in the U.S. Early estimates of costs of CRs suggested \$1400/kW<sub>e</sub> (1990 dollars) as achievable with mass production techniques. At present costs of ERDA's pilot plant project, this goal is a factor of 10 to 15 away from realization. If cost reductions of this magnitude cannot be realized then the central receiver will probably not be economically competitive in this century. The government could choose to subsidize the industry in the hope of stimulating cost reductions, which could cause a limited market penetration. In any event, the future market for CR plants is uncertain.

If CRs were built by the present industries in the U.S., then about 10,000 man years would be required to build a 100 MW<sub>e</sub> intermediate load

power plant according to our model. This is approximately 2.5 times more labor intensive than coal produced energy per unit energy output. This high labor cost partially explains the high cost of building CR plants. Mass production will reduce these labor requirements but the extent of this reduction is unknown and difficult to estimate accurately.

The large amounts of materials required to build a CR plant are listed in the text for several designs. These material requirements lead to considerable secondary pollutants. The CR is superior to coal or residual oil for major air pollutants and for CO<sub>2</sub>, but is inferior to natural gas for everything except CO<sub>2</sub>. Our model results are inconclusive regarding water pollutants, but the CR is almost certainly inferior to natural gas, and it may be comparable or somewhat worse than coal or residual oil.

According to the economic model used in the test, producing 10 GW<sub>e</sub> per year of CR plants would produce considerable increases in demand on a number of industries and occupations, on the order of 10% over 1972 levels for the most affected ones.

Evaporative cooling devices used with Rankine cycle systems in the southwest will increase the demand for water and demographic shifts to that region would accentuate the problem. If these devices were used, and extensive implementation occurred, then large programs for increasing water supply would probably be required.

The large land areas that CR plants require would remove a corresponding amount of species habitat at the plant site, and perhaps in the vicinity of the plant as well. Some endangered species may be affected,

depending on the sites selected. The construction and maintenance of the plants will scar the desert surface and increase erosion. Substantial amounts of dust may also be released into the atmosphere. Increased populations in desert regions would further reduce the area of virgin desert and increase the frequency of human intervention in remote regions.

Many changes could occur in the micro-climate around a central receiver plant, but none appear to be a cause for serious concern. Evaporation rates and turbulent diffusion rates would be modified at the plant site. If evaporative cooling devices are used, then fogging may be a problem for some atmospheric conditions. Dew retention and formation rates may be increased under the heliostat canopy. Convection currents about the cooling towers may lead to a slight increase in dust, especially in an unstable atmosphere, but the magnitude of these currents will probably be small compared to the natural winds of the deserts, except close to the cooling towers.

With extensive construction of central receiver plants, some regional or global atmospheric effects may occur. If the CR plants decreased the regional albedo, then precipitation would almost certainly increase. If vast amounts of dust were released during the construction of these plants, this could also modify precipitation.

Solar energy conversion is generally considered to be more benign environmentally and more labor intensive than fossil fuel conversion. This report supports this general conclusion for the case of the CR, with some qualifications. Our models suggest for example that natural gas

is superior to CRs for all major pollutants, air and water. The effect on the desert environment of CR construction will be locally severe. Implementing CR technology will lead to a trade-off between traditional pollutants and desert wilderness areas. The land areas which would be affected by the CR are, however, small compared to the total suitable land. Water requirements will be a significant problem for the CR. Climate problems, although not fully examined, do not appear to be of paramount concern.

Appendix 1 - Heliostat Designs

ERDA has funded four heliostat designs. These are the most important ones in the present situation, although some other design may ultimately prove more suitable for economic implementation of the central receiver. The four contracts have been given to Boeing, Honeywell, McDonnell-Douglas, and Martin-Marrietta. We shall review each of these in turn.

Boeing - The Boeing heliostat is novel in that it would be enclosed in a plastic bubble as shown in figure A1-1. The following data has been collected from the Boeing Semi-Annual reviews of this project.

Mirror Reflectivity - .886 at normal incidence

.934 at 45° incidence

Dome Transmissivity - .884 at normal incidence

0 at 0° incidence.

East - West Spacing - 8.44 m - 23.22 m.

North - South Spacing - 10.04 m - 15.5 m.

Single Collector area - 37 m<sup>2</sup>

Field density - 29%

# of heliostats for a 10 MW<sub>e</sub> plant - 2,814

Collector Area - 104,018 m<sup>2</sup>

Approximate material requirements per heliostat: (preliminary estimates)

Aluminum - 118 lb.

Steel - 1810 lb.

Tedlar - 25 lb.

Polyethylene - 41 lb.

Mylar - 10 lb.

Polyurethane - 4 lb.

Concrete - 17,500 lb.

The virtues of this design are that the reflector surface is protected from the elements by a protective plastic bubble, thereby enabling the heliostat to be made lighter, and eliminating the need to wash the mirror. The disadvantages of the design are that considerable losses are incurred as the radiation passes twice through the plastic bubble, and this bubble may degrade in time. It may also be necessary to wash the plastic periodically and this could present problems.

Honeywell - The Honeywell heliostat is shown in figure A1-1. The Honeywell design is novel in that it uses a type of venetian blind coupling, much like a Fresnel lens. It presents a smaller cross section to the wind and therefore the atmospheric drag forces are smaller. On the other hand it requires more moving parts to provide the mechanical coupling between the mirrors of a single heliostat.

Collector Area - 40 m<sup>2</sup>

# of heliostats for a 10 Mw<sub>e</sub> plant - 2320

Total area of reflective surface - 92,800 m<sup>2</sup>

Field size - circular, 308 m radius.

Field Density - .31

#### Materials Requirements

Structure-4525 lb.

Glass-495 lb.

Concrete - 14,500 lb.

McDonnell Douglas - The McDonnell Douglas heliostat is shown in figure A1-1. The following detailed information was surmised from several McDonnell Douglas reports. Since all of the heliostat designs are undergoing constant change, the reader interested in more accurate figures should contact the company. The reflector is octagonally shaped, with first surface silvered float glass + acrylic protective coating for 8 segments.

Collector area -  $30.8 \text{ m}^2$

# of heliostats for a  $10 \text{ MW}_e$  plant - 2,290

Approximate material requirements per heliostat (preliminary estimates):

Heliostat Foundation - Concrete =  $.765 \text{ m}^3 = 8400 \text{ lb.}$

Rebar = 46 lb.

Sand = 8000 lb.

Total = 16,446 lb.

Heliostat Pedestal - Low Carbon Steel = 380 lb.

Heliostat Drive - Low Carbon Steel = 990 lb.

Bearings and Actuators = 170 lb.

Motors = 28 lb.

Total = 1188 lb.

Reflector - Low Carbon Steel = 990 lb.

Glass = 1,070 lb.

Silver = 26 gm.

Acrylic 100 gm.

Beam Sensor Foundation - Concrete = 5,040 lb.

Rebar = 91 lb.

Beam Sensor Post - Low Carbon Steel = 140 lb.

Beam Sensor - Silicon Solar Cell Chips = 5 chips

PC Board and Connector 1 cm<sup>2</sup> = 1 unit

ABS Plastic Housing = 1 gm

Heliostat Cabling - 26 strand copper (131 ft)

Martin-Marrietta - The Martin-Marrietta heliostat is shown in figure A1-1. The following information has been gathered from various reports and is subject to change. The reader intrested in more accurate information should contact Martin-Marrietta.

Collector Area - 37.2 m<sup>2</sup>

# of heliostats for a 10 MW<sub>e</sub> plant - 1718

Total area of reflective surface for 10 MW<sub>e</sub> plant - 63,866 m<sup>2</sup>

Field size - 565 m x 565 m

Field density - 20%

Two designs, one with 25 small mirrors and one with 9 small mirrors are being considered by Martin-Marrietta. Both have the same total reflector area. Information on both will be given when available.

	<u>25 mirror</u>	<u>9 mirror</u>
Overall Heliostat		
Weight	5129 lb.	5084 lb.
Number of mirrors	25	9
Envelope dimensions	22.5 x 22 ft.	22 x 22.75 ft.
Reflecting area	37.2 m <sup>2</sup>	37.2 m <sup>2</sup>
Mirror Assembly and Supports		
Size	1.2 x 1.2 m.	2.03 x 2.03 m.



	Variable	Fixed (400 m.)
Focusing		
Substrate Material	Tubular Steel	Honeycomb
Glass Thickness	.25 in.	.25 in.
Spectral Reflectivity	91%	73%
# of support struts per heliostat	10	6
# of pointing adjustments	50	18
# of focusing adjustments	25	none
<b>Main Structure</b>		
Yoke width	4.1 m.	2.4 m.
Yoke height	3.6 m.	3.6 m.
Yoke vertical member	.3 m.	.25 m.
Yoke horizontal member	Steel, .3x.3 m.	same
<b>Rotational Limits</b>		
Azimuth	+ 110° maximum	+ 110° maximum
Elevation	+ 180° maximum	+ 180° maximum

Foundation Weight- comparable to the other designs.

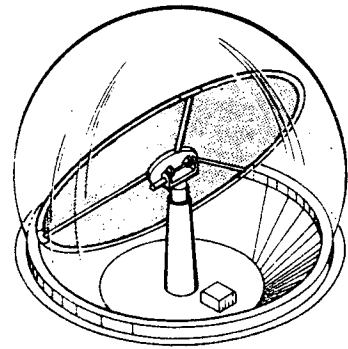

BOEING

HONEYWELL

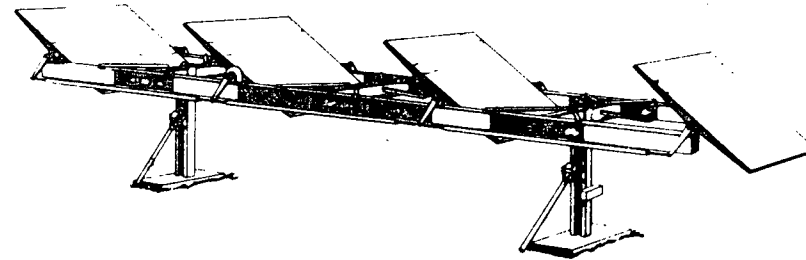

MARTIN  
MARIETTA

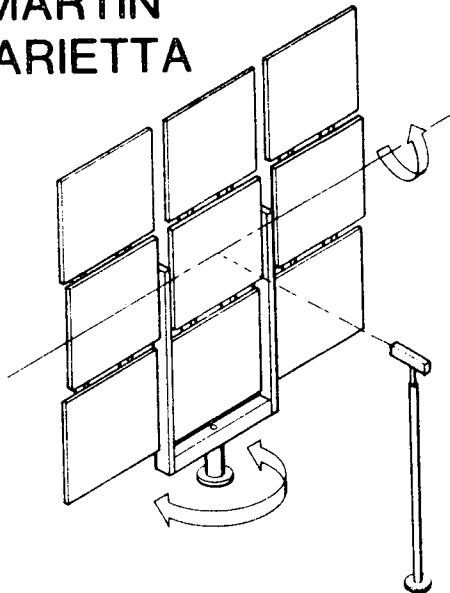

MC DONNELL DOUGLAS

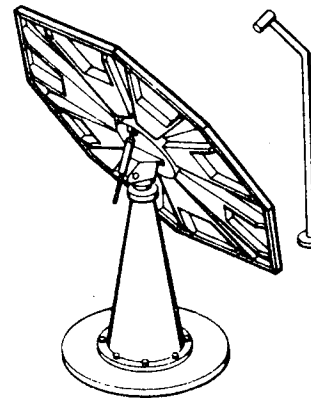

Pilot Plant Heliostat Concepts

Fig. AI-1

XBL 774-8284

Appendix 2 - Rest of Plant

Several reviews of the ERDA funded designs may be found in the literature. Selcuk (1975) has presented a survey of the designs as of August 1975. Additional information may be laboriously surmised from the Preliminary Baseline Reports of the four ERDA contractors and from their periodic status reports. An up to date collection of literature of this type is maintained at Sandia Laboratories, Livermore, CA. Table A2-1 presents a very summary comparison of the three major designs (Honeywell, McDonnell Douglas, Martin Marrietta). Some additional results are presented below.

Honeywell

Honeywell has considered both slip form concrete and welded tubular steel towers. For the 10 MW<sub>e</sub> pilot plant its height would be about 146 m. The fractional cost breakdown for a system using 1450 psia, 950°F steam and salt storage is as follows:

Collector Subsystem - 34.8%  
Storage Subsystem - 21.5%  
Turbine - 4%  
Cooling Towers - 7.5%  
Plant Balance - 2.9%  
Receiver - 5.5%  
Tower - 6.5%  
Indirect Expenses - 17.3%

The major plant characteristics as obtained from the Preliminary Baseline Report are: (for the 10 MW<sub>e</sub> pilot plant)

Field Outer Radius - 290 m

# of heliostats - 1905

Tower Height - 137 m.

Cavity Diameter - 11.4 m.

Cavity height - 14 m.

Thermal Storage Capacity - 200 MWhr (t)

Total Quantity of Phase Change Material

(NaCl-NaNO<sub>3</sub>-Na<sub>2</sub>SO<sub>4</sub>, NaCl-NaOH) - 4.5 x 10<sup>6</sup> kg.

Turbine Name Plate Capacity - 15,000 kw.

High-Pressure Steam Turbine Inlet - 1450 psi/950°F

Low-Pressure Steam Turbine Conditions - 575 psi/534°F

Peak Thermal Power Into Aperture - 53.2 MW

Annual Thermal Energy Into Cavity Aperture - 1.58 x 10<sup>5</sup> MWhr

Net Annual Thermal Energy Per Unit Mirror Area - 1.95 MWhr/m<sup>2</sup>

Net Peak Power Per Unit Mirror Area (Thermal) - .66 kW/m<sup>2</sup>

Maximum Thermal Power Input to Storage - 49 MW

Maximum Thermal Power Output from Storage - 29.8 MW

Peak Steam Flow Rate to Turbine Inlet - 202,765 lb/hr

The heliostat field is circular. The collector field would be flat to minimize grading. The receiver is a right circular cylindrical cavity located at the top of the tower. Feedwater and high pressure steam lines provide the links between the steam generator at the top of the tower and other subsystems at grade elevation.

McDonnell Douglas - Specifications for 10 MW<sub>e</sub> plant unless otherwise specified.

# of heliostats 2290

Tower Height (10 MW<sub>e</sub>) - 101.4 m.

Receiver Diameter - 7.0 m.

Receiver Height - 24.4 m.

# of absorbing panels - 24

Tower Design - square cross section, cantilever K-braced frames,  
supported on square concrete footing.

Tower width at top - 6.1 m

Tower base width - 15.24 m

Estimated tower cost - \$915,000

Thermal Storage Unit - Cylindrical tank

Diameter - 19.4 m

Height - 17.3 m

Heat transfer/storage fluid - 312,000 gal  
of Caloria HT-43

Heat Storage - 10,600 tons of crushed granite

Operating Temp. Range - 425 to 575°F

Relative Cost Breakdown -

Collector Subsystem - 55%

Receiver Subsystem - 5%

Tower Subsystem - 4%

Riser/Downcomer Subsystem - 3%

Thermal Storage Subsystem - 9.5%

Master Control System - .5%

Turbine Generator - 12.5%

Electric Plant - 2%

Structures, General Plant, and other - 5.6%

Estimated Cost per Killowatt (e) - from \$1000 to \$1300

Martin-Marrietta

Storage Requirements - 6 hrs operation at 7 MW<sub>e</sub> output.

Plant lifetime - 30 yr.

Scheduled plant maintenance - 25 days/yr

Annual Net output - 34,000 MW<sub>e</sub>-hr

Time to fullpower - Diurnal - 20 minutes

From Cold Start - 6 hrs.

Steam Conditions at turbine inlet - 950°F/1275 psig

Terrain - either flat or terraced

Receiver - Cavity type

Storage - Two stage using sensible heat - HITEC for high temperature  
storage - Hydrocarbon oils for low temperature storage.

Solar Energy to Receiver Design Point - 52 MW<sub>t</sub>

Feedwater input flow rate - 153,000 lb/hr

Feedwater input temperature - 403°F

Cavity Aperture - 7.5 x 7.5 m

Open Cycle Gas Turbine Design - The following data was presented

as a preliminary reference system design by Black and Veatch Corp.

at the EPRI semi-annual review in March, 1977. This Brayton design

uses air as a working fluid. It has a fossil fuel backup system

instead of thermal storage. This reference system has a rated output

of 50 MW<sub>e</sub>.

Collector Field

Outer field radius

Maximum 460 m.

Minimum 310 m

Inner field radius	100 m
Ground area	$0.41 \times 10^6 \text{m}^2$
Ground cover ratio	
Maximum	0.69
Minimum	0.43
Average	0.56
Mirror Area	$0.23 \times 10^6 \text{m}^2$
Number of Heliostats	6200
<b>Heliostats</b>	
Mirror area	$37 \text{m}^2$
Focusing strategy	Focal length = Slant range
Mirror reflectivity	0.85
Mirror material	Glass, second surface
Support frame material	Steel
Construction	Field assembly of factory components
Weight	3,000 kg
<b>Tracking Control System</b>	
Tracking	Tilt-tilt
Tracking control	Open loop, central computer
Design Day Redirected Energy,	$1200 \text{MWhr}_t$
Clear Air Model	
<b>Receiver Support Tower</b>	
Height	183 m
Diameter at base	23 m
Diameter at top	12 m
Wall thickness at base	0.4 m

Wall thickness at top	0.9 m
Construction method	Slip-form or jump-form
Construction material	Steel reinforced concrete
Weight (including tower mat)	
Quantity of steel	$6.8 \times 10^6$ kg.
Quantity of concrete	$4.3 \times 10^7$ kg.

#### Receiver Cavity

Number	4
Nominal inner width	13.7 m
Nominal inner height	12.2 m
Wall thickness	33 cm
Conversion efficiency	0.855
Aperture efficiency	0.925
Cavity efficiency	0.925

#### Solar Heat Exchanger

Peak incident flux	$400 \text{ kW/m}^2$
Interior wall panels	$\text{Al}_2\text{O}_3$
Thickness	2 cm

#### Tubes

Material	Silicon Carbide
Length	12.2 m
Diameter	10 cm
Number of U-tubes	213

#### Inlet Conditions

Temperature	$482^\circ\text{C}$
Pressure	130 psia



Outlet Conditions

Temperature	1038°C
Pressure	126 psia

Interface Ducting

To heat source

Number of ducts	4
Pipe material	0.8 m
Wall thickness	0.006 m
Total duct length	244 m
Insulation	
Internal	None
External	0.025 m

From heat source

Number of ducts	4
Pipe material	1.3 m
Wall thickness	0.006 m
Total duct length	244 m
Insulation	
Internal	0.13 m
External	0.025 m

Overall Subsystem Height	198 m
--------------------------	-------

Gas Turbine

Nameplate Rating	51 MW <sub>e</sub>
Speed	3600

Design inlet conditions

Temperature 1038°C  
Pressure 126 psia

Generator

Nameplate rating 60 MW<sub>e</sub>  
Cooling Air

Turbine - Generator Output

Receiver/Turbine mode

Capacity 51 MW<sub>e</sub>  
Turbine inlet air  
Source Receiver  
Temperature 1038°C  
Pressure 126 psia  
Flow rate 771,000 kg/hr

Storage/Turbine Mode

Capacity 51 MW<sub>e</sub>  
Turbine inlet air  
Source Fuel combustors  
Temperature 1038°C  
Pressure 125 psia  
Flow rate 771,000 kg/hr

Combustor Heat Input Capacity 480 MBtu/hr

Ambient Air Intake Height 74 m

Air/Gas Exhaust Stack

Height 198 m  
Exit cross-sectional area 14 m<sup>2</sup>

Exit air/gas velocity 27 m/s

Exit air/gas temperature 340°C

Table A2-1

PRELIMINARY CHARACTERISTICS OF 10 MW<sub>e</sub> SOLAR CENTRAL RECEIVER POWER PLANT

	Boeing	Honeywell	Martin-Marietta	McDonnell-Douglas
<u>Annual Energy (MW-hr)<sub>e</sub></u>		4.0 X 10 <sup>4</sup>	3.4 x 10 <sup>4</sup>	3.6 x 10 <sup>4</sup>
<u>Collector Subsystem</u>				
Heliostat Construction	metallized plastic reflector; aluminum and steel frame with plastic dome	second-surface glass mirror; low profile steel frame, multifaceted, focused	second-surface glass mirror, steel frame, multifaceted, focused	first-surface glass mirror, steel frame, multifaceted, focused
Number of Heliostats	2814	1682	1718	2200
Reflective Surface per Heliostat	37 m <sup>2</sup>	40 m <sup>2</sup>	37.2 m <sup>2</sup>	30.8 m <sup>2</sup>
Total Area Reflective Surface	104,018 m <sup>2</sup>	67,280 m <sup>2</sup>	63,843 m <sup>2</sup>	67,760 m <sup>2</sup>
Field Size		548 m diameter	653 m x 555 m	552 m x 502 m
<u>Receiver Subsystem</u>				
Receiver Type		vertical cavity	horizontal cavity	external absorber
Tower Height		130 m	90 m	75 m
Receiver Working Fluid		water/steam	water/steam	water/steam
<u>Storage Subsystem</u>				
Storage Mechanism		sensible heat	sensible heat	sensible heat
Storage Media		oil/rocks/Hitec	oil/HITEC	oil/rocks
<u>Electrical Generation Subsystem</u>				
Turbine Rating		15 MW <sub>e</sub>	12.5 MW <sub>e</sub>	12.5 MW <sub>e</sub>
Turbine Fluid		steam	steam	steam
Turbine Inlet Conditions				
From Receiver		510°C, 10.1 MPa	510°C, 9.3 MPa	510°C, 10.1 MPa
From Storage		390°C, 3.2 MPa	430°C, 2.8 MPa	270°C, 3.4 MPa

XBL 774-8286

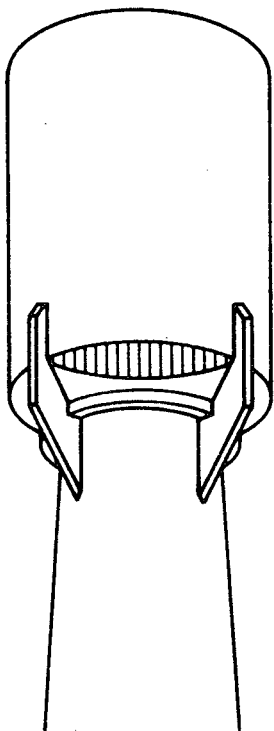

HONEYWELL

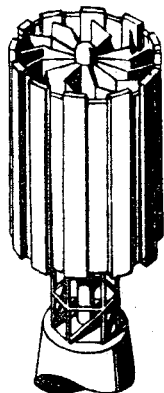

MC DONNELL  
DOUGLAS

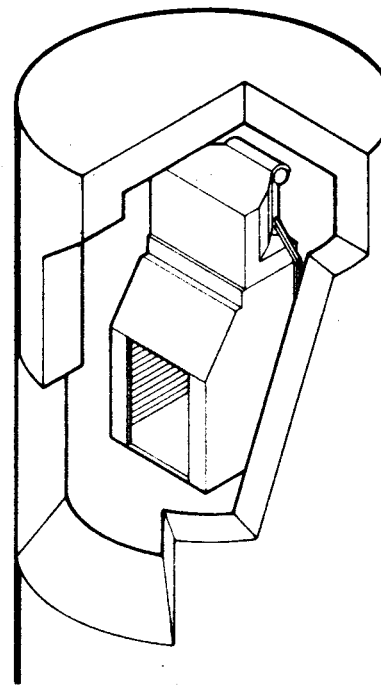

MARTIN MARIETTA

Pilot Plant Receiver Concepts

Fig. AII-1

XBL 774-8283

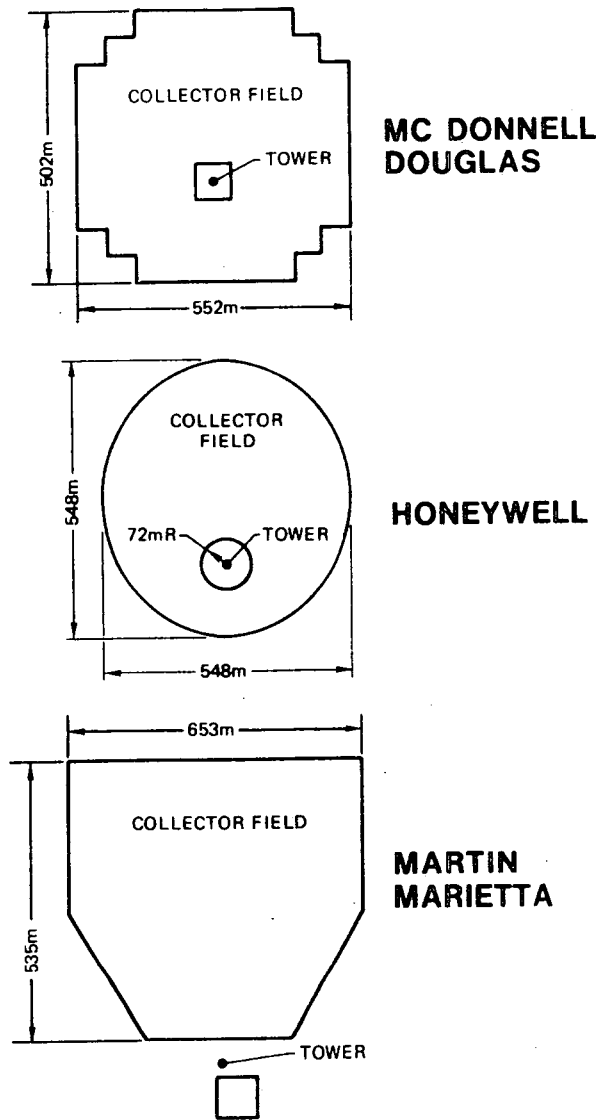

Comparison of the Mirror Field Layouts  
XBL 774-8285

Fig. AII-2

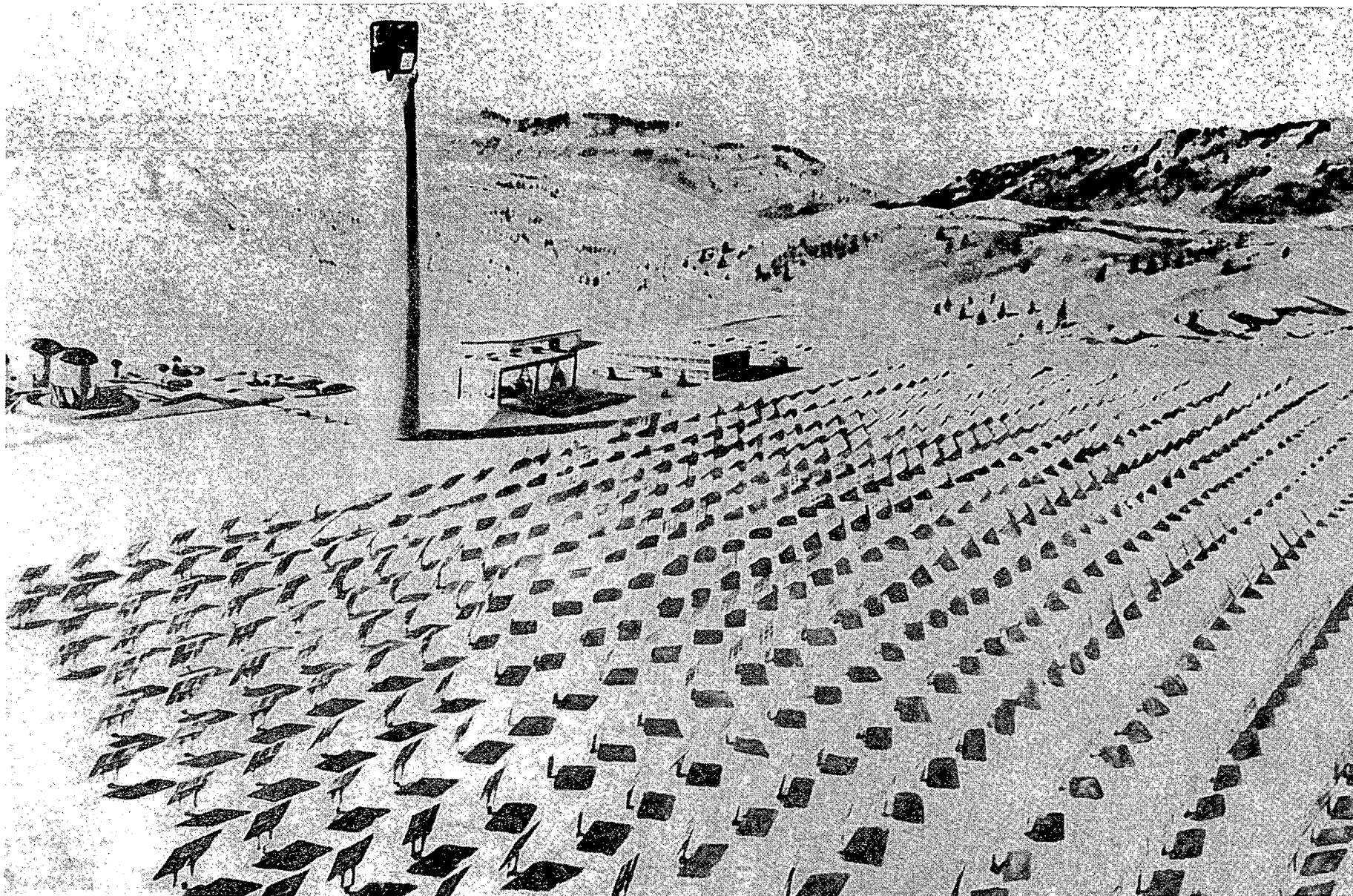

XBB 774-2984

Fig. AII-3

**Martin Marietta 10-MW<sub>e</sub> Pilot Plant Design. The receiver is north-facing, the thermal storage tanks are at the far left, and the electrical generation system is in the open structure near the base of the tower.**



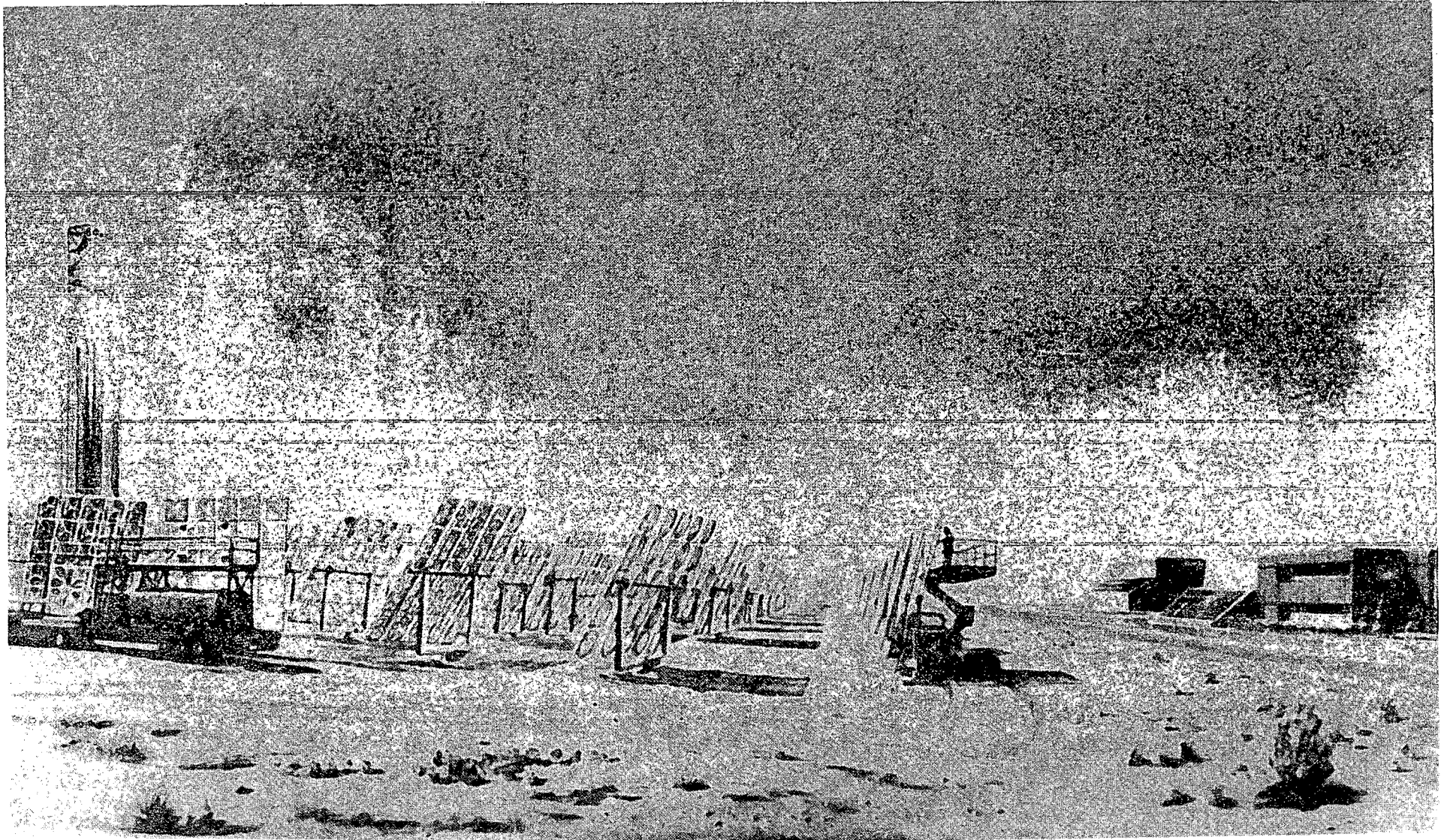
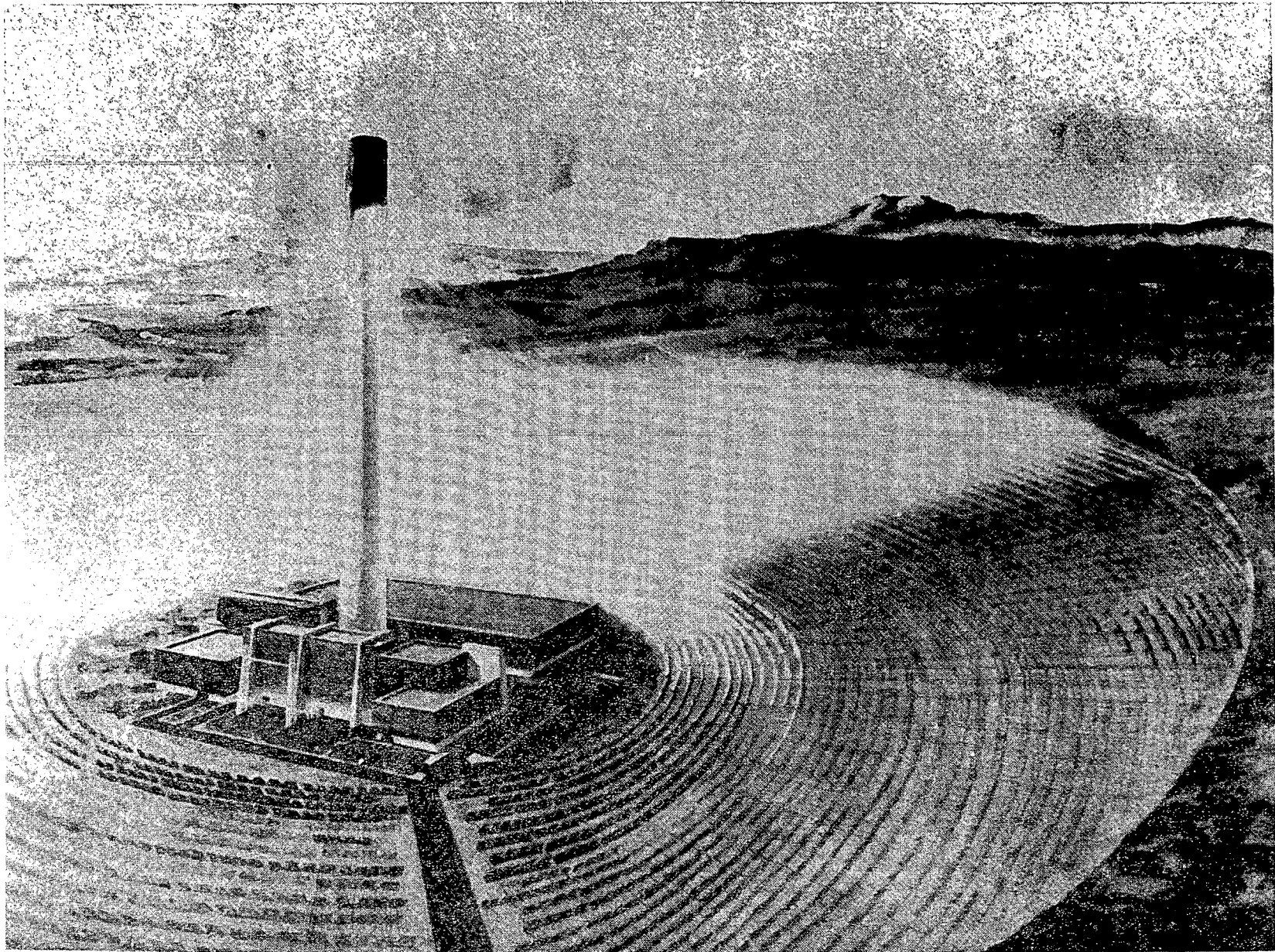

Fig. AII-4

**Solar Thermal Test Facility**

XBB 774-2983





XBB 774-2981

Fig. AII-5 **Honeywell 10-MW<sub>e</sub> Pilot Plant Design.** Note that the electrical generation subsystem and thermal storage are located at the base of the tower.

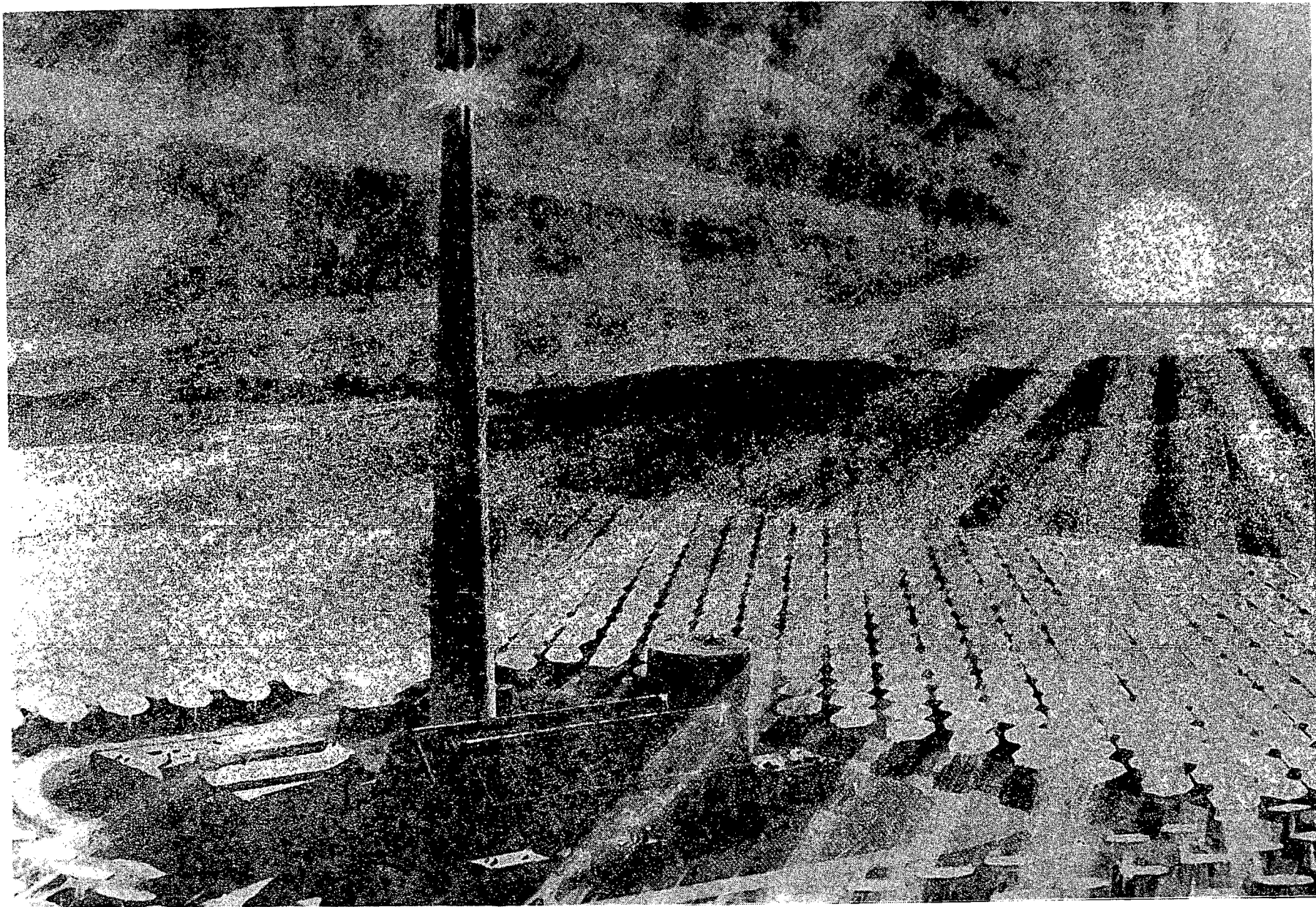

XBB 774-2982

Fig. AII-6

**McDonnell Douglas 10-MW<sub>e</sub> Pilot Plant Design. The heliostat field surrounds the thermal storage (single circular tank), tower, and electrical generation subsystems. Note the octagonal shaped heliostats.**

(Courtesy of Honeywell)

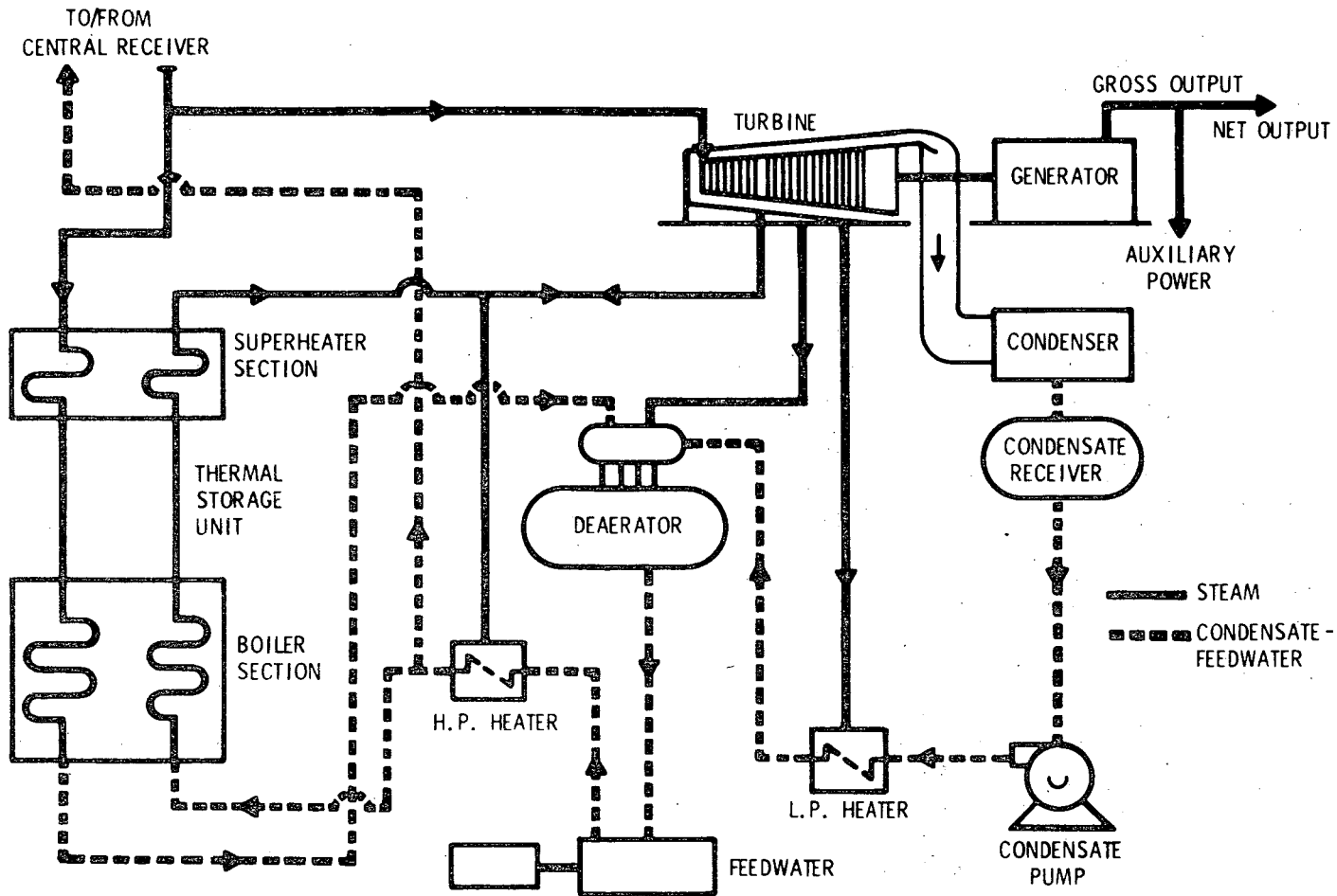

-130-

Fig. AII-7 Honeywell Preliminary Central Receiver Solar Thermal Power System

XBL 774-8280

(Courtesy of McDonnell-Douglas)

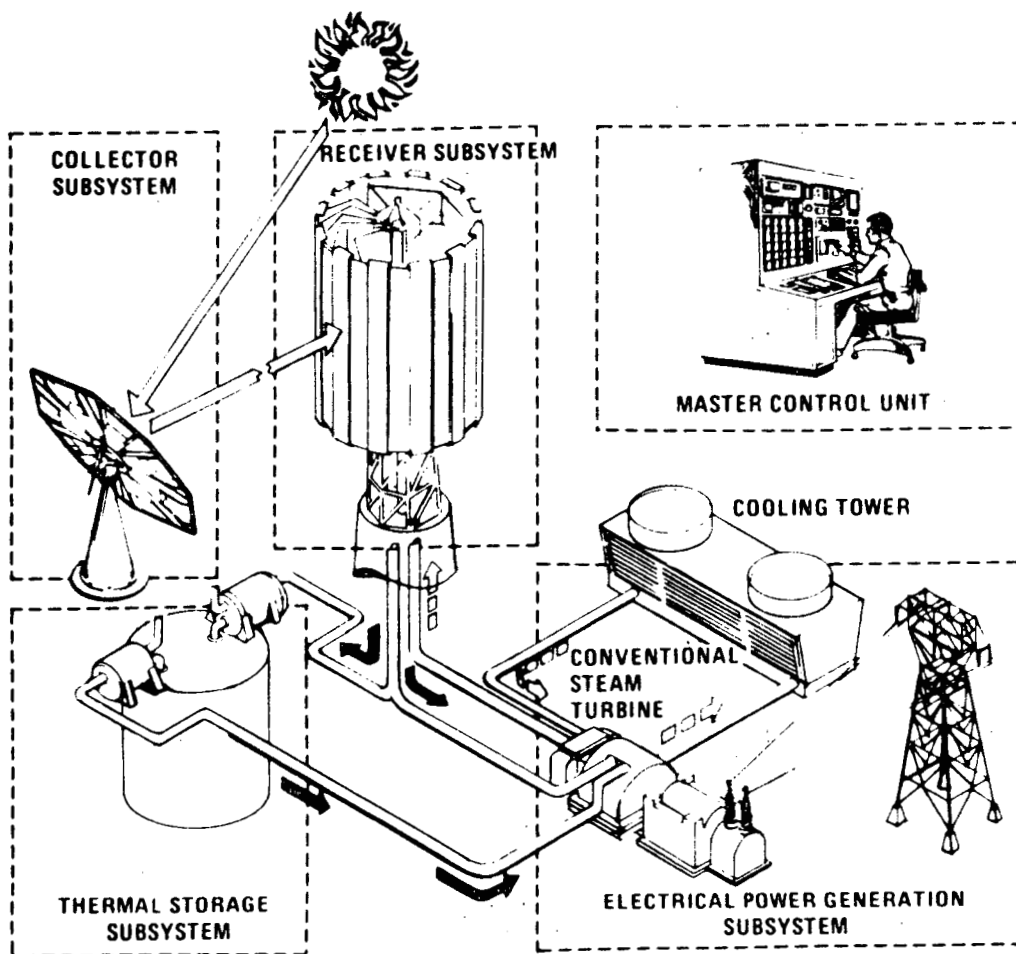

McDonnell-Douglas Preliminary Central Receiver Solar Thermal Power System

XBL 774-8281

Fig. AII-8

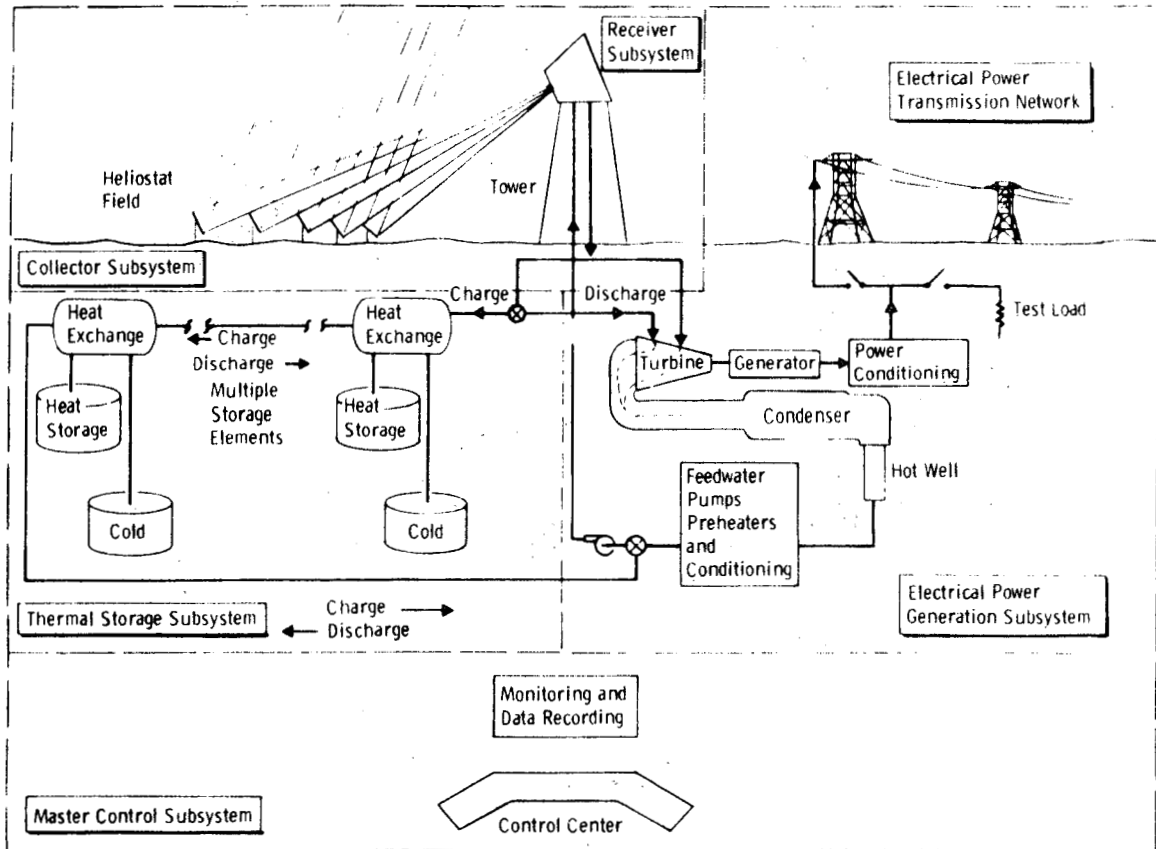

(Courtesy of Martin Marietta)

Fig. AII-9 Martin Marietta Preliminary Central Receiver Solar Thermal Power System

XBL 774-8282



Glossary

base load power

A steady, non-fluctuating power requirement.

Brayton engine

An engine characterized by adiabatic compression of cool gases, heating at constant pressure, and finally adiabatic expansion through a turbine to produce work. Also a turbojet.

CID

Cumulative increase in demand, total increase in demand or output, resulting from multiplying some initial vector of increases on industrial demand by an input/output total requirements matrix.

closed Brayton cycle

A Brayton cycle in which expansion gases are recaptured, cooled, and reused.

CO

Carbon Monoxide.

Coriolis force

In atmospheric physics, an east or west force experienced by bodies moving north or south.

DID

Direct increase in demand

diffuse radiation

Short wave radiation which has been scattered by the atmosphere.

direct radiation

Short wave radiation which has not been scattered by the atmosphere.

diurnal

Having a daily cycle.

enthalpy

The sum of the internal energy of a body and the product of its volume multiplied by its pressure.

EPRI

Electric Power Research Institute, Palo Alto, CA.

ERDA

Energy Research and Development Agency.

eutectic salt

A salt having a low melting point.

evapotranspiration

The loss of water from the soil both by evaporation and by transpiration from the plants growing thereon.

flat plate collector

A flat absorber of short wave radiation which converts it into heat. Usually covered with a material transparent to short wave but opaque to infrared radiation.

GCM

General Circulation Model.

ground cover ratio

The ratio of mirror area to land area for a central receiver plant.

Hadley cell

An atmospheric circulation cell causing tropical rains and subtropical deserts.

helios tat

Mirrors which can track the sun and are used to focus direct radiation on a central receiver.

hybrid system

A central receiver which uses an auxilliary fossil fuel system for backup.

Intermediate load power

Power required more than six hours a day, but less than 12 twelve hours a day.

latent heat

Heat which is transferred to a body and affects a phase change such as converting liquid water to water vapor.

mes oscale

On a scale of several hundred  $\text{km}^2$  to several thousand  $\text{km}^2$ . Pertaining to atmospheric models.

microscale

On a scale of 1 to several hundred km<sup>2</sup> in land area, pertaining to atmospheric phenomena.

modular design

A central receiver design using several towers and field to produce steam which is piped to a central generator station.

NO<sub>x</sub>

Nitrogen oxides.

open Brayton cycle

A once through Brayton cycle using air. Expansion gases are released into the atmosphere.

Parabolic trough

A horizontal, troughlike mirror with parabolic cross section used to focus direct radiation onto a line collector.

paraboloidal dish

A parabolic mirror used to focus direct radiation onto a small area to produce high temperatures and produce useful energy.

peaking power

Power required during peak hours, usually in the afternoon for about 6 hours.

planetary albedo

The percent short wave radiation reflected back into space by the earth, including reflection off the atmosphere.

playa

The flat floored bottom of an undrained desert basin that becomes at times a shallow salty lake.

radiative cooling

cooling that is caused by a body losing heat through radiation.

Rankine engine

A steam engine.

runoff rate

The amount of water leaving a unit area of land annually by running off it in rivers and gulleys.



SEAS

Strategic Environmental Assessment System.

sensible heat

Heat transferred to a body which goes into changing its temperature without inducing a phase change.

SIC

Standard Industrial Classification

Solar ponds

Ponds used to produce warm water. May be shallow and covered, or deep utilizing salinity gradient to suppress convection.

SO<sub>x</sub>

Sulfur oxides.

subsidence

A descending atmosphere.

surface albedo

The percent short wave radiation reflected by the surface of the planet, usually expressed as a daily average.

temperature lapse rate

The variation of temperature with altitude.

Turbidity

In atmospheric physics, the presence of particles in the atmosphere which scatter short wave radiation.

working fluid

A fluid in a heat engine which undergoes thermodynamic changes and does work.

ZAM2

A zonally averaged global model developed at Livermore Laboratory.

REFERENCES FOR THE CENTRAL RECEIVER STUDY

- Abbey, Edward. 1968. Desert Solitaire, Ballantine Books, New York.
- The Aerospace Corporation. 1974. Solar Thermal Conversion Mission Analysis, El Segundo, Ca.
- Baier, W. 1966. "Studies on Dew Formation Under Semi-Arid Conditons," Agricultural Meteorology, 3, pp. 103-112.
- Bechtel Corp. 1975. The Energy Supply Planning Model, Vols. I and II, NSF contract #NSF-C867, San Francisco.
- Bethe, H. A. 1976. "The Necessity of Fission Power," Scientific American, Vol. 234, No. 1, pp. 21-31, January.
- Blake, F. A. 1976. "Central Receiver Solar Thermal Power," in Sharing the Sun, Vol 5, Ed. by K. W. Böer, International Solar Energy Society.
- Bockris, J. O. M. 1975. Energy: The Solar-Hydrogen Alternative, John Wiley and Sons, New York.
- Boeing Corp. 1976. Central Receiver-Solar Thermal Power System Collector Subsystem; Semi-Annual Review, ERDA Contract EY-76-C-03-1111, Dec. 7.
- Bryson, R. A. and Baerreis, D. A. 1967. "Possibilities of Major Climatic Modification and Their Implications: Northwest India, A Case for Study", Bulletin of the American Meteorological Society, Vol. 38, pp. 136-142.
- Bureau of Economic Analysis. 1974. "The Input-Output Structure of the U.S. Economy: 1967," Survey of Current Business, Feb. 1974.
- Case, G. D., Bertolli, T. A., Bodington, J. C., Choy, T. A., and Nero, A. V. 1977. Health Effects and Related Standards for Fossil-Fuel and Geothermal Power Plants, Lawrence Berkeley Laboratory report # LBL-5287.
- Charney, J. 1975. "Dynamics of Deserts and Drought in the Sahel," Quart. J. R. Met. Soc., 101, pp. 193-202.
- Charney, J., Stone, P. H., and Quirk, W. J. 1975. "Drought in the Sahara: A Biogeophysical Feedback Mechanism," Science 187, 434-435.
- Cooke, R. U. 1973. Geomorphology in Deserts, University of California Press, Berkeley.

- Currier, E. L., Knox, J. B., and Crawford, T. V. 1974. "Cooling Pond Steam Fog," Journal of the Air Pollution Control Association, 24, pp. 860-864.
- Davidson, M. and Grether, D. 1976. "Some Aspects of the Effects of Solar Energy Conversion on Climate," Proceedings of the International Workshop on Climate and Solar Energy Conversion, International Institute of Applied Systems Analysis, Vienna.
- Davidson, M., Grether, D., Herovitz, M. 1976. "Assessment of the Socio-Economic and Environmental Aspects of the Central Receiver Power Plants," Proceedings of the International Solar Energy Society Joint Conference, Winnipeg, Canada, 9, 91.
- Davidson, M., Grether, D., and Wilcox, K. 1977. Ecological Considerations of the Solar Alternative, Lawrence Berkeley Laboratory Report LBL 5927.
- Davis, S. N. 1974. "Hydrogeology of Arid Regions," in Desert Biology, Vol. II, Ed. by G. W. Brown, Jr., Academic Press, New York.
- Easton, C. R., Raetz, J. E., and Vant-Hull, L. L. 1976. "Collector Field Design for a Central Receiver Solar Thermal Power Plant," in Sharing the Sun, Vol. 5, Ed. by K. W. Böer, International Solar Energy Society.
- Ellsaesser, H. W., MacCracken, M. C., Potter, G. L., and Luther, F. M. 1976. "An Additional Model Test of Positive Feedback from High Desert Albedo," Quart. J. R. Met. Society, 102, pp. 655-666.
- ERDA. 1976. A National Plan for Energy Research, Development and Demonstration: Creating Energy Choices for the Future. Vol 1: The Plan, ERDA 76-1, U.S. GPO Stock # 052-010-00478-6.
- Espey, Huston, Associates. 1974. Consumptive Water Use Implications of the Proposed EPA Effluent Guidelines for Steam-Electric Power Generation, Austin, Texas, May 31.
- Fuller, W. H. 1974. "Desert Soils," Ch. 2 in Desert Biology, Vol. II, Ed. by G. W. Brown, Jr., Academic Press, New York.
- Haltiner, G. J., and Martin, F. L. 1975. Dynamical and Physical Meteorology, McGraw-Hill, New York.
- House, P. 1977. Trading Off Environment, Economics, and Energy: A Case Study of EPA's Strategic Environmental Assessment System, to be published (Lexington Books, Cambridge, Mass.).

- International Solar Energy Society. 1975. Sharing the Sun, Vol. 5: Solar Thermal and Ocean Thermal.
- Killian, H. J., et al. Eds. 1975. Solar Energy for Earth, on AIAA Assessment, American Institute of Aeronautics and Astronautics.
- Landsberg, H. E., Lippmann, H., Paffen, K. H., and Troll, C. 1966. World Maps of Climatology, Springer-Verlag, Berlin.
- MacCracken, M. C. and Luther, F. M. 1974. "Climate Studies Using a Zonal Atmospheric Model", in Proceedings of the International Conference on Structure, Composition, and General Circulation of the Upper and Lower Atmosphere, and Possible Anthropogenic Perturbations, W. L. Godson, ed., Vol. 2, pp. 1107-1128, Melbourne.
- Makhijani, A. B., and Lichtenberg, A. J. 1972. "Energy and Well-Being," Environment, Vol. 14, No. 5.
- McGinnies, G. W. et al. eds. 1968. Deserts of the World, University of Arizona Press, Tucson.
- Meinel, A. B., and Meinel, M. P. 1976. Applied Solar Energy, An Introduction, Addison-Wesley, New York.
- Merrill, D. 1976. Estimates of 1972 U.S. Employment for Use in Input Output Applications, Lawrence Berkeley Lab. Energy and Environment Division Annual Report.
- Mesarovic, M. and Pestel, E. 1974. Mankind at the Turning Point, Signet, New York.
- Monteith, J. L., "Dew," Royal Meteorological Society, Quarterly Journal, 83, pp. 322-341.
- Office of Management and Budget. 1972. Standard Industrial Classification Manual 1972, GPO stock # 4101-0066.
- Pollard, W. G. 1976. "The Lag-Range Prospects for Solar Energy," American Scientist, Vol. 64, pp. 424-429.
- Potter, G. L., Ellsaesser, H. W., MacCracken, M. C., and Luther, F. M. 1975. "Possible Climatic Impact of Tropical Deforestation", Nature, Vol. 258, pp. 697-698.
- Priestley, C. H. B. 1955. "Free and Forced Convection in the Atmosphere Near the Ground," Q.J.R. Met. Soc., 81, pp. 139-143.
- Priestley, C. H. B. and Ball, F. K. 1955. "Continuous convection from an isolated source of heat," Q.J.R. Met. Soc., 81, pp. 144-157.
- Priestley, C. H. B. 1959. Turbulent Transfer in the Lower Atmosphere, The University of Chicago Press, Chicago.
- Robbins, C. S., Bruun, B., and Zim, H. S. 1966. Birds of North America, Golden Press, New York.

- Sathaye, Jayant, et al. 1977. Analysis of California Energy Industry, Lawrence Berkeley Laboratory Report, #LBL-5928.
- Schneider, S. H. and Mesirov, L. E. 1976. Genesis Strategy, Plenum Press, New York.
- Schnell, R. C. 1975. "The Biogenic component of Sahelian Eolian dust: A possible drought factor," EOS, 56, pp. 994-995.
- Selcuk, M. K. 1975. Survey of Several Central Receiver Solar Thermal Power Plant Design Concepts, Jet Propulsion Laboratory, #EM 342-311, Pasadena, California, August.
- Sellers, W. D. 1965. Physical Climatology, University of Chicago Press, Chicago.
- Stebbins, R. C. 1966. Field Guide to Western Reptiles and Amphibians, Houghton Mifflin Company, Boston.
- Stebbins, Robert C. 1974. Off-Road Vehicles and the Fragile Desert," The American Biology Teacher, Vol. 36, No. 4, April.
- Stern, A. C., Ed. 1968. Air Pollution, 3 volumes, Academic Press, New York.
- Sutton, O. G. 1953. Micrometeorology, McGraw-Hill, New York.
- Water Resources Council, 1968. The Nation's Water Resources.
- Weingart, J. 1977. Local Energy Balance Effects of Solar Thermal Electric on Photovoltaic Power Plants - Some Preliminary Results, Proceedings of the Workshop on Climate and Solar Energy, International Institute for Applied Systems Analysis, Vienna.
- Wilshire, H. G. and Nakata, J. K. 1976. "Off-Road Vehicle Effects on California's Mojave Desert," California Geology, California Division of Mines and Geology, Sacramento, June.
- Wollman, N. and Bonem, W. 1971. The Outlook for Water, The Johns Hopkins Press, Baltimore.

This report was done with support from the United States Energy Research and Development Administration. Any conclusions or opinions expressed in this report represent solely those of the author(s) and not necessarily those of The Regents of the University of California, the Lawrence Berkeley Laboratory or the United States Energy Research and Development Administration.

TECHNICAL INFORMATION DEPARTMENT  
LAWRENCE BERKELEY LABORATORY  
UNIVERSITY OF CALIFORNIA  
BERKELEY, CALIFORNIA 94720