

UC Irvine

UC Irvine Previously Published Works

Title

Mitotic tethers connect sister chromosomes and transmit "cross-polar" force during anaphase A of mitosis in PtK2 cells.

Permalink

<https://escholarship.org/uc/item/2hb47070>

Journal

Biomedical Optics Express, 8(10)

ISSN

2156-7085

Authors

Ono, Matthew
Preece, Daryl
Duquette, Michelle L
[et al.](#)

Publication Date

2017-10-01

DOI

10.1364/boe.8.004310

Peer reviewed



Mitotic tethers connect sister chromosomes and transmit “cross-polar” force during anaphase A of mitosis in PtK2 cells

MATTHEW ONO,¹ DARYL PREECE,^{1,2,*} MICHELLE L. DUQUETTE,¹ ARTHUR FORER,³ AND MICHAEL W. BERNS^{1,4}

¹Department of Bioengineering, University of California, San Diego, CA 92093, USA

²Department of NanoEngineering, University of California, San Diego, La Jolla, CA 92093, USA

³Department of Biology, York University, Toronto, ON M3J 1P3, Canada

⁴Beckman Laser Institute and Department of Biomedical Engineering, University of California Irvine, CA 92617, USA

*dpreece@ucsd.edu

Abstract: Originally described in crane-fly spermatocytes, tethers physically link and transmit force between the ends of separating chromosomes. Optical tweezers and laser scissors were used to sever the tether between chromosomes, create chromosome fragments attached to the tether which move toward the opposite pole, and to trap the tethered fragments. Laser microsurgery in the intracellular space between separating telomeres reduced chromosome strain in half of tested chromosome pairs. When the telomere-containing region was severed from the rest of the chromosome body, the resultant fragment either traveled towards the proper pole (poleward), towards the sister pole (cross-polar), or movement ceased. Fragment travel towards the sister pole varied in distance and always ceased following a cut between telomeres, indicating the tether is responsible for transferring a cross-polar force to the fragment. Optical trapping of cross-polar traveling fragments places an upper boundary on the tethering force of ~1.5 pN.

© 2017 Optical Society of America

OCIS codes: (000.1430) Biology and medicine; (170.1530) Cell analysis.

References and links

1. D. J. Gordon, B. Resio, and D. Pellman, “Causes and consequences of aneuploidy in cancer,” *Nat. Rev. Genet.* **13**(3), 189–203 (2012).
2. T. Hassold, M. Abruozzo, K. Adkins, D. Griffin, M. Merrill, E. Millie, and M. Zaragoza, “Human aneuploidy: Incidence, origin and etiology,” *Envir. and Mol. Mutagenesis* **28**(3), 167–175 (1996).
3. A. Suzuki, B. L. Badger, J. Haase, T. Ohashi, H. P. Erickson, E. D. Salmon, and K. Bloom, “How the kinetochore couples microtubule force and centromere stretch to move chromosomes,” *Nature Cell Biol.* **18**(4), 382–392 (2016).
4. L. Matsson, “Chromatin compaction by condensin I, intra-kinetochore stretch and tension, and anaphase onset, in collective spindle assembly checkpoint interaction,” *J. Phys. Condensed Matter* **26**(15), 155102 (2014).
5. Y. Wang, F. Jin, R. Higgins, and K. McKnight, “The current view for the silencing of the spindle assembly checkpoint,” *Cell Cycle bseries* **13**(11), 1694–701 (2014).
6. F. Jin, and Y. Wang, “The signaling network that silences the spindle assembly checkpoint upon the establishment of chromosome bipolar attachment,” *PNAS* **110**(52), 21036–21041 (2013).
7. P. Keating, N. Rachidi, T. U. Tanaka, and M. J. R. Stark, “Ipl1-dependent phosphorylation of Dam1 is reduced by tension applied on kinetochores,” *J. Cell Sci.* **122**, 4375–4382 (2009).
8. D. E. Koshland, T. J. Mitchison, and M. W. Kirschner, “Polewards chromosome movement driven by microtubule depolymerization in vitro,” *Nature* **331**(6156), 499–504 (1988).
9. G. C. Rogers, S. L. Rogers, T. A. Schwimmer, S. C. Ems-McClung, C. E. Walczak, R. D. Vale, and D. J. Sharp, “Two mitotic kinesins cooperate to drive sister chromatid separation during anaphase,” *Nature* **427**(6972), 364–370 (2004).
10. S. Inoué, and E. D. Salmon, “Force generation by microtubule assembly/disassembly in mitosis and related movements,” *Mol. Biol. Cell* **6**(12), 1619–1640 (1995).
11. J. F. Marko, and M. G. Poirier, “Micromechanics of chromatin and chromosomes,” *Biochem. and Cell Biol.* **81**(3), 209–220 (2003).
12. M. Sun, R. Kawamura, and J. F. Marko, “Micromechanics of human mitotic chromosomes,” *Phys. Biol.* **8**(1), 1–18 (2011).
13. G. Cojoc, R. Roscioli, L. Zhang, A. Garcia-Ulloa, J. V. Shah, M. W. Berns, and J. Gregan, “Laser microsurgery reveals conserved viscoelastic behavior of the kinetochore,” *J. Cell Biol.* **212**(7), 767–776 (2016).

14. W. F. Marshall, J. F. Marko, D. A. Agard, and J. W. Sedat, "Chromosome elasticity and mitotic polar ejection force measured in living *Drosophila* embryos by four-dimensional microscopy-based motion analysis," *Current Biology* **11**(8), 569–578 (2001).
15. R. B. Nicklas, "Measurements of the force produced by the mitotic spindle in anaphase," *J. Cell Biol.* **97**(2), 542–548 (1983).
16. R. B. Nicklas, "Chromosome Function Velocity During Mitosis As a of Chromosome Size and Position," *J. Cell Biol.* **25**(1), 119–135 (1965).
17. S. P. Alexander, and C. L. Rieder, "Analysis of Force Production by Nascent Kinetochores Fibers," *Cell* **113**(4), 805–815 (1991).
18. M. W. Berns, W. H. Wright, B. J. Tromberg, G. Profeta, J. J. Andrews, and R. J. Walter, "Use of a laser-induced optical force trap to study chromosome movement on the mitotic spindle," *Proceedings of the National Academy of Sciences* **86**(12), 4539–4543 (1989).
19. H. Liang, W. H. Wright, S. Cheng, W. He, and M. W. Berns, "Micromanipulation of chromosomes in PtK2 cells using laser microsurgery (optical scalpel) in combination with laser-induced optical force (optical tweezers)," *Exp. Cell. Research* **204**(1), 110–120 (1993).
20. H. Liang, W. H. Wright, C. L. Rieder, E. Salmon, G. Profeta, J. J. Andrews, and M. W. Berns, "Directed Movement of Chromosome Arms and Fragments in Mitotic Newt Cells Using Optical Scissors and Optical Tweezers," *Experimental Cell Research* **213**, 308–312 (1994).
21. N. Khatibzadeh, A. B. Stilgoe, A. M. Bui, Y. Rocha, G. M. Cruz, V. Loke, and M. W. Berns, "Determination of motility forces on isolated chromosomes with laser tweezers," *Sci. Rep.* **4**, 6866 (2014).
22. B. Houchmandzadeh, J. F. Marko, D. Chatenay, and A. Libchaber, "Elasticity and structure of eukaryote chromosomes studied by micromanipulation and micropipette aspiration," *J. Cell Biol.* **139**(1), 1–12 (1997).
23. J. Ferraro-Gideon, R. Sheykhan, Q. Zhu, M. L. Duquette, M. W. Berns, and A. Forer, "Measurements of forces produced by the mitotic spindle using optical tweezers," *Mol. Biol. Cell* **24**, 1375–1386 (2013).
24. J. R. LaFountain, R. W. Cole, and C. L. Rieder, "Partner telomeres during anaphase in crane-fly spermatocytes are connected by an elastic tether that exerts a backward force and resists poleward motion," *J. Cell Sci.* **115**(7), 1541–1549 (2002).
25. R. Sheykhan, M. W. Berns, and A. Forer, "Elastic tethers between separating anaphase chromosomes in crane-fly spermatocytes coordinate chromosome movements to the two poles," *Cytoskeleton* **74**(2), 91–103 (2017).
26. A. Forer, M. L. Duquette, L. Paliulis, E. Fegaras, M. Ono, D. Preece, and M. W. Berns. "Elastic 'tethers' connect separating anaphase chromosomes in a broad range of animal cells," *European Journal of Cell Biology*, (to be published).
27. M. S. Harsono, Q. Zhu, L. Z. Shi, M. L. Duquette, and M. W. Berns, "Development of a dual joystick-controlled laser trapping and cutting system for optical micromanipulation of chromosomes inside living cells," *J. Biophoton.* **6**, 197–204 (2013).
28. M. Ono, D. Preece, M. L. Duquette, and M. W. Berns, "Mitotic tethers connect sister chromosomes during anaphase A in PtK2 cells," in *Optics in the Life Sciences Congress, Optical Trapping Applications 2017* (Optical Society of America, 2017), paper OTM4E.4.

1. Introduction

During mitosis various biochemical and mechanical cues guide the controlled segregation of chromosomes. The proper combination of these cues is necessary to preserve cellular function and avoid aneuploidy in the resulting daughter cells. Cells with an abnormal number of chromosomes, a condition known as aneuploidy, over-express or lack vital genetic information. While abnormal chromosome number usually results in cell death, some aneuploid cells continue proliferation which can result in tumorigenesis, congenital birth defects, and miscarriage [1, 2]. The exact cellular machinery involved in this precise segregation of genetic material is still an area of active interest.

Mechanical involvement of subcellular structures plays crucial roles in the regulation of mitosis. Recently, tension in the kinetochores of chromosomes has been shown to cue the metaphase-to-anaphase transition and reposition centromere substructures to improve chromosome movement [3–7]. Here we are interested in the chromosomal stress resulting from the kinetochore motility force in the anaphase A stage of mitosis. During the anaphase stage of mitosis sister chromatids are divided and the chromosomes transported to the poles of the cell by a Brownian ratchet mediated kinetochore force and microtubule depolymerization [8–10]. While useful parameters such as tension, strain, and elastic modulus can be studied using biosensors, and *ex vivo* experimentation [3, 11–15], the underlying physical forces which move chromosomes

in anaphase (motility force) are not well known. Mathematical models derived from study of *Melanoplus*, *Drosophila*, and *T. granulosa* cells estimate motility force as ~ 0.1 - 1 pN [14, 16, 17]. Early optical trapping experiments demonstrated chromosomes could be manipulated by an optical trap *in vitro* [18] and *in vivo* [19, 20], estimating a force to move chromosomes of ~ 30 pN. Later trapping experiments on Chinese hamster ovary cells found 0.1-12 pN sufficient to move extracted chromosomes [21], and 2-10 pN stopped *in vivo* chromosome movement in *Mesostoma* and crane-fly cells [23]. However, in pioneering micromanipulation experiments with *Melanoplus* spermatocytes R.B Nicklas impaled moving anaphase chromosomes with a glass needle and determined that a force of 700 pN was needed to stop chromosome movement [15]. Thus there is no agreement on the force acting on chromosomes during anaphase.

For these studies we understand the chromosome as a body whose observable deformation emerges as a result of real physical forces and strains. Chromosomes are linearly extensible bodies whose stiffness largely depends on chromosomal substructure [11, 12]. Thus when strained in the lengthwise direction chromosomes can be conceptualized as springs whose elongation reflects an applied force. Deformation of chromosomes during anaphase is often attributed to intracellular drag force acting along the chromosome's length and varying with velocity, thereby forming the basis for minimum motility force estimates [14, 22]. However, LaFountain et. al. found that two of four sister chromatids in crane-fly spermatocytes were linked by a physical tether connecting their telomere regions such that a 'cross-polar' force elongated segregating chromosomes and moved severed chromosome fragments through the cell [24]. Recent studies confirmed these findings in crane-fly spermatocytes and found that chromosome elongation could be reduced by severing this tether [25, 26]. Laser microsurgery can help deduce the mechanistic basis for chromosomal elongation in PtK cells by attempting to sever the tether and examining length change, or by generating chromosome fragments—which are presumably attached to the tether—and examining their travel. Furthermore, optically trapping the chromosome fragments offers a limited but non-intrusive method of measuring forces acting on the chromosome.

2. Materials and methods

Mammalian PtK2 epithelial cells were used in this study for their relatively low chromosome number and less rounding during mitosis, helping to improve imaging clarity. Cells were cultured in DMEM with 10% fetal bovine serum, penicillin, and streptomycin, and plated on 35mm glass bottom imaging dishes (MatTek) for experiments. During imaging the dish temperature, 5%CO₂, 20%O₂, and humidity were maintained with a microscope stage incubator and gas mixer (Ibidi Temperature Controller and Gas Mixer).

Experiments were performed on Robolase IV, a system that combines a microscope with optical cutting and trapping capabilities (Fig. 1) [21, 23, 27]. Briefly, the optical scissors were generated by a pulsed femtosecond 740nm beam (Ti:Sapphire), and the optical trap was a continuous, 1064nm (Nd:YVO4) beam. Images were captured from a Zeiss Axiovert with a 63x, 1.4 NA oil immersion objective every 2 seconds with a Hamamatsu CCD camera (Orca-R²) while stage control, beam steering, and irradiance exposure were mediated through a LabView VI.

To examine chromosome strain due to tethering, chromosome length was followed before and after laser microsurgery of the intracellular space between separating telomeres. Chromosome lengths were determined by taking the chromosome's lengthwise profile for each time step, along the line which the kinetochore and tail end follow to the pole. The profile from each time step was concatenated in ImageJ to create a kymograph yielding position-time data. Chromosomes that deviated from a single linear path during the trial were not used. Chromosome length for 30-60s prior to and following the inter-telomere cut was averaged. Chromosome's whose length shortened after cutting by more than the standard deviation prior to cutting were determined to have experienced strain reduction. Mean strain reduction was then calculated by dividing the

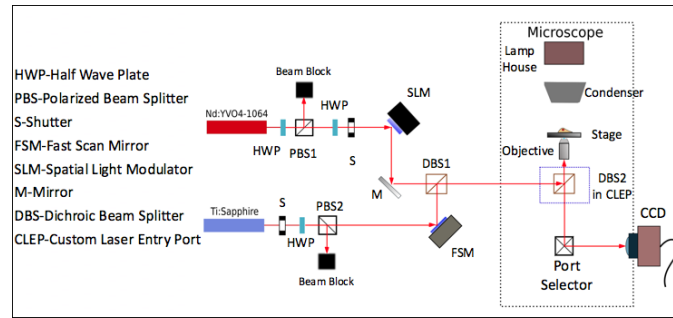

Fig. 1. Diagram of the optical train illustrating the optical path of the tweezers and scissors into the microscope and the image path into the CCD camera.

mean length after the inter-telomere cut by the mean length prior to the cut.

In order to verify that a physical element was responsible for transmitting force to the chromosome ends microsurgery was used to sever chromosome arms and create fragments containing the telomere region. In one group fragments were allowed to travel freely until the end of anaphase. In a subsequent group, fragments were allowed to travel freely for 30-60s before applying an inter-telomere cut, aiming to sever the tether and stop cross-polar travel. Fragment travel was again analyzed by creating position-time kymographs in ImageJ, from which mean velocity for the time following fragmentation and the time following the inter-telomere cut could be calculated.

For cutting trials the pulsed 740 nm laser was set to a pulse power of $2.25 \times 10^3 \text{ J/s}$ (irradiance of $1.27 \times 10^9 \text{ W/cm}^2$ at the sample) at the sample plane. To ensure chromosomes and linking elements are cut entirely, the cut was performed in three focal planes each $0.5 \mu\text{m}$ apart.

Chromosomes were severed and fragments which exhibited cross-polar travel were trapped shortly after fragmentation to estimate the magnitude of the tethering force. Optical trapping of moving fragments was accomplished by placing the trap center over the fragment but slightly ahead of its centroid such that the fragment passes over the trap center where the effective force is negligible. For optical trapping the continuous 1064 nm laser power was set at 13mW (irradiance of $3.56 \times 10^3 \text{ W/cm}^2$ at the sample) at the sample plane, a power for which heating and photochemistry effects are expected to be small [21]. Effective optical trapping force on a chromosome can be calculated by Eq. (1) [20, 21, 23].

$$F = \frac{Q'P}{c} \quad (1)$$

Where F is the effective trapping force, P is the power at the focal plane, c is the speed of light in vacuum, and Q' is a dimensionless factor which relates the efficiency of force producing incident light for a specific geometry and composition. Q' values have been measured on chromosome fragments in newt lungs as 0.034 [20, 23] and on isolated CHO chromosomes as 0.01-0.02 [21].

3. Results

Inter-telomere cuts resulted in a statistically significant strain reduction of $7 \pm 4\%$ in roughly half ($n=14$) of tested chromosomes. The remaining chromosomes ($n=17$) did not show significant strain reduction.

When chromosomes were severed during anaphase transport, the remaining arm attached to the kinetochore always segregated successfully. Chromosome fragments showed large variations in the magnitude of cross-polar travel as fragments either moved towards the cell equator ($n=4$), crossed the equator ($n=5$), or ceased movement ($n=2$). A small fraction of fragments segregated

to the proper pole ($n=2$) (Fig. 2).

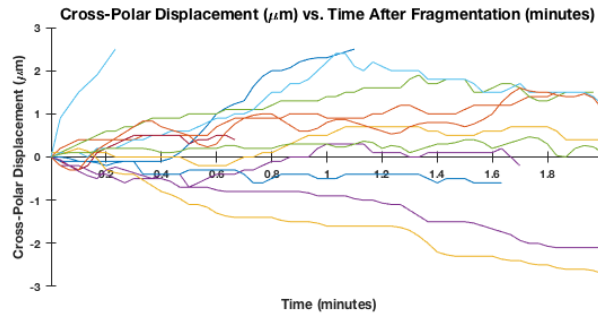

Fig. 2. Cross-Polar displacement (μm) of chromosome fragments from their initial cut position. Positive displacement indicates fragment travel towards the sister chromosome in the cross-polar direction. Fragments exhibit a wide range of travel distances and velocities.

In a different group of chromosomes when a cut was directed in front of cross-polar traveling fragments, all fragments ($n=12$) either stopped or reversed direction and then traveled towards the appropriate pole (Fig. 3).

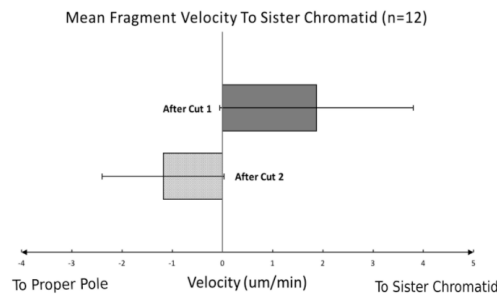

Fig. 3. Mean fragment velocity ($\mu\text{m}/\text{min}$) after fragmentation (Cut 1) and after the inter-telomere cut (Cut 2); error bars are standard deviation from the mean. All fragments travelling towards the sister pole either stopped or reversed direction following Cut 2 indicating the cut disabled a physical element transmitting force to the fragment.

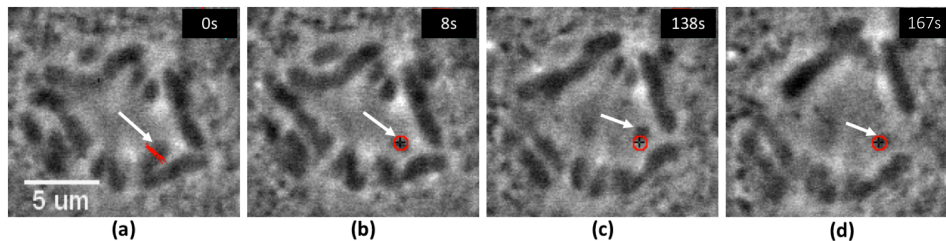

Fig. 4. Frames from video of severing and trapping a cross-polar travelling fragment (see Visualization 1). (a) Chromosome arm as the laser cut (red lines) is being performed. (b) 1064 nm optical trap (red circle) over fragment centroid where effective trapping force is negligible. (c) Chromosome fragment continues traveling towards and remains at the trap edge on the sister chromosome side. (d) Fragment returns to the center of the optical trap nearing the end of anaphase.

Moving chromosomal fragments were trapped at a power of 13 mW in the focal plane. This was sufficient to cease cross-polar travel; all fragment centroids ($n=3$) were able to move 1.5-2.5 μm past the trap center towards the opposite pole, as shown in Fig. 4(c). The trap power corresponds to a ~ 1.5 pN force utilizing the upper boundary Q' value =0.034, and 0.4 pN when using $Q'=0.01$. Fragment centroids gradually returned towards the center of the trap nearing the end of anaphase A, shown in Fig. 4(d).

4. Discussion and conclusions

Tethers strain chromosome arms during anaphase transport. Laser cuts in the cellular space between sister chromosome ends revealed a source of chromosome strain independent of drag force. In roughly half of tested chromosomes, cuts between separating chromosome ends resulted in a mean relaxation of $7\pm 4\%$ suggesting that the laser severed a physical linkage, thereby reducing chromosomal strain. Chromosomes that did not shorten may not have been affected as the laser failed to sever a tether, or these chromosome arms were not tethered. The relaxation of only half of PtK2 chromosomes is consistent with findings that only half of chromatids are tethered in crane-fly spermatocytes [24–26]. When severing chromosomes during transport, kinetochore attached arms successfully segregated while chromosome fragments either did not move significantly, briefly travelled towards the opposing pole and stopped, or fully travelled to and remained at the sister side. Moreover, travel to the sister side was stopped or reversed when a laser cut was directed at the space between chromosome ends, severing the tether. Fragment travel showed that the tethering force is more than sufficient enough to move fragments through the cytoplasm. Differences in the duration and distance of this cross-polar travel suggest the tethering element may lose elastic integrity as anaphase progresses such that it can no longer transmit sufficient force to move a fragment as proposed in LaFountain et. al. [24].

Optical trapping of cross-polar traveling fragments appears to provide an upper boundary of ~ 1.5 pN for the tethering force as fragments were able to travel past the trap center but were not able to escape the trap rim. The tethering force seemingly lessened towards the end of anaphase as fragments returned to the trap center. While the tethering force carries other implications as to the material nature of the tether and anaphase forces at large, this will not be assessed in this article but more widely addressed in an upcoming article by Forer et. al [26].

Funding

Air Force Office of Scientific Research under award number FA9550-17-1-0193, and a grant from the Natural Sciences and Engineering Research Council of Canada.

Acknowledgments

The authors would also like to acknowledge the Beckman Laser Institute and the Institute of Engineering in Medicine. Portions of this research were presented at the OSA Biophotonics Congress: Optics in the Life Sciences in 2017 [28].

Disclosures

The authors declare that there are no conflicts of interest related to this article.