

# Lawrence Berkeley National Laboratory

## Recent Work

### **Title**

Water Infiltration and Intermittent Flow in Rough-walled Fractures

### **Permalink**

<https://escholarship.org/uc/item/2q94f8t0>

### **Author**

Su, Grace

### **Publication Date**

1995-05-01



# ERNEST ORLANDO LAWRENCE BERKELEY NATIONAL LABORATORY

## Water Infiltration and Intermittent Flow in Rough-Walled Fractures

Grace Su  
Earth Sciences Division

May 1995  
M.S. Thesis

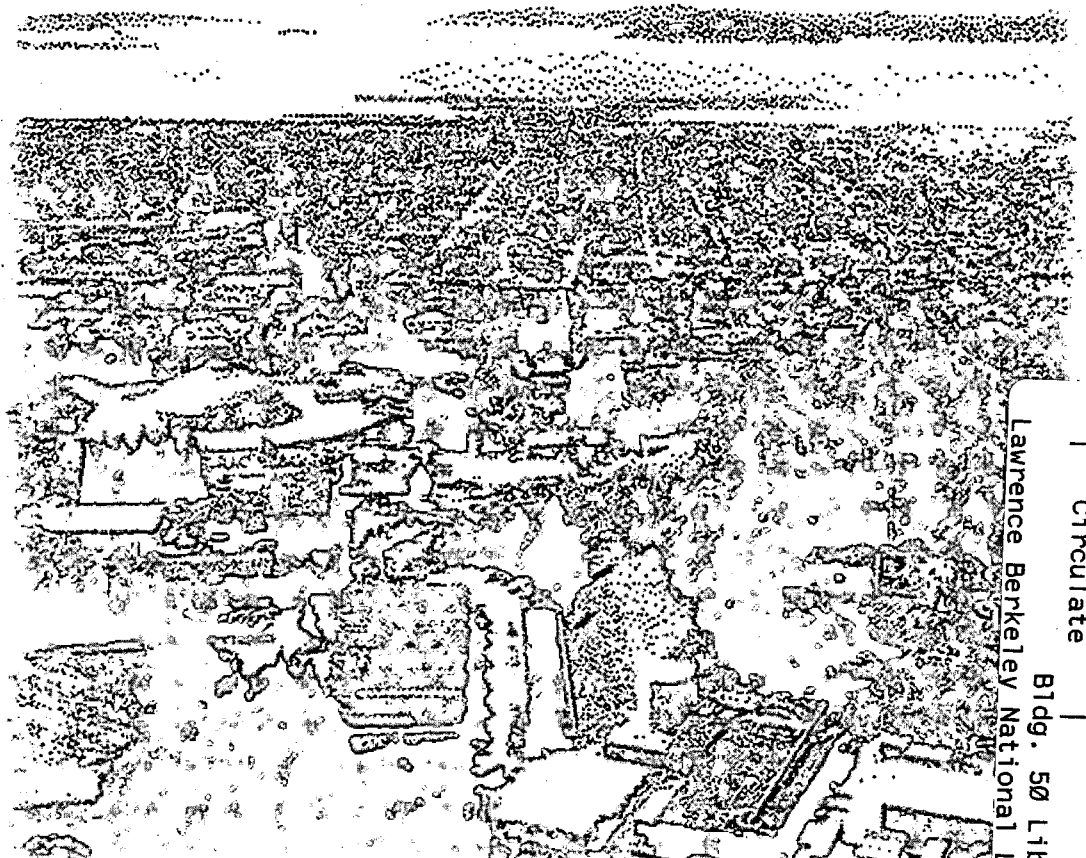

REFERENCE COPY  
Does Not Circulate  
Bldg. 50 Library - Ref.  
Lawrence Berkeley National Laboratory  
Copy 1  
LBL-37462

#### **DISCLAIMER**

This document was prepared as an account of work sponsored by the United States Government. While this document is believed to contain correct information, neither the United States Government nor any agency thereof, nor The Regents of the University of California, nor any of their employees, makes any warranty, express or implied, or assumes any legal responsibility for the accuracy, completeness, or usefulness of any information, apparatus, product, or process disclosed, or represents that its use would not infringe privately owned rights. Reference herein to any specific commercial product, process, or service by its trade name, trademark, manufacturer, or otherwise, does not necessarily constitute or imply its endorsement, recommendation, or favoring by the United States Government or any agency thereof, or The Regents of the University of California. The views and opinions of authors expressed herein do not necessarily state or reflect those of the United States Government or any agency thereof, or The Regents of the University of California.

Ernest Orlando Lawrence Berkeley National Laboratory  
is an equal opportunity employer.

## **DISCLAIMER**

This document was prepared as an account of work sponsored by the United States Government. While this document is believed to contain correct information, neither the United States Government nor any agency thereof, nor the Regents of the University of California, nor any of their employees, makes any warranty, express or implied, or assumes any legal responsibility for the accuracy, completeness, or usefulness of any information, apparatus, product, or process disclosed, or represents that its use would not infringe privately owned rights. Reference herein to any specific commercial product, process, or service by its trade name, trademark, manufacturer, or otherwise, does not necessarily constitute or imply its endorsement, recommendation, or favoring by the United States Government or any agency thereof, or the Regents of the University of California. The views and opinions of authors expressed herein do not necessarily state or reflect those of the United States Government or any agency thereof or the Regents of the University of California.



**Water Infiltration and Intermittent Flow  
in Rough-Walled Fractures**

Grace Su  
M.S. Thesis

Department of Civil Engineering  
University of California at Berkeley

and

Earth Sciences Division  
Lawrence Berkeley Laboratory  
University of California  
Berkeley, CA 94720

May 1995

**TABLE OF CONTENTS**

<b>ABSTRACT</b> .....	<b>1</b>
<b>1.0 INTRODUCTION</b> .....	<b>2</b>
<b>2.0 TASKS OF WATER INFILTRATION AND INTERMITTENT FLOW EXPERIMENTS</b> .....	<b>2</b>
<b>3.0 APPARATUS AND EXPERIMENTAL PROCEDURE</b> .....	<b>3</b>
3.1 <i>Water Infiltration Experiments</i> .....	3
3.2 <i>Parallel Plate Experiments</i> .....	4
<b>4.0 RESULTS AND DISCUSSION</b> .....	<b>6</b>
4.1 <i>Water Infiltration Experiments</i> .....	6
4.2 <i>Parallel Plates Experiments</i> .....	7
<b>5.0 CONCLUSIONS</b> .....	<b>9</b>
<b>6.0 FUTURE RESEARCH</b> .....	<b>10</b>
<b>7.0 ACKNOWLEDGMENTS</b> .....	<b>11</b>
<b>8.0 REFERENCES</b> .....	<b>11</b>
<b>9.0 TABLE AND FIGURE CAPTIONS</b> .....	<b>12</b>
<b>APPENDIX</b>	

**Abstract**

Flow visualization experiments were conducted in transparent replicas of natural rough-walled fractures. The fracture was inclined to observe the interplay between capillary and gravity forces. Water was introduced into the fracture by a capillary siphon. Preferential flow paths were observed, where intermittent flow frequently occurred. The water infiltration experiments suggest that intermittent flow in fractures appears to be the rule rather than the exception. In order to investigate the mechanism causing intermittent flow in fractures, parallel plates with different apertures were assembled using lucite and glass. A medium-coarse-fine pore structure is believed to cause the intermittency in flow. Intermittent flow was successfully produced in the parallel plate experiments using the lucite plates. After several trials, intermittent flow was also produced in the glass plates.

## **1.0 Introduction**

Characterizing the flow in fractured media is important for determining the suitability of a site for nuclear waste repository, studying the movement of contaminants such as non-aqueous phase liquids (NAPL's), and the recovery of oil from petroleum reservoirs. Infiltration of liquid into the unsaturated zone of fractured rocks has gained much interest recently. Water infiltrating into fractured rocks could have strong implications on solute transport and is therefore a primary concern for evaluating the design and suitability of a site for a nuclear waste repository. The Yucca Mountain site in Nevada is, for example, currently being evaluated for its suitability as a nuclear waste repository. The potential repository would be placed within a fractured unsaturated rock composed of ash flow and volcanic tuffs.

Geller and Pruess (1995) performed laboratory and numerical experiments in rough-walled fractures to study the characteristics of preferential flow during water infiltration. In their experimental studies, they found that the water flowed in an unsteady manner along preferential flow paths even though steady boundary conditions were maintained at the inlet. In particular, Geller and Pruess observed intermittent flow along the flow paths. Numerical studies of infiltration in a two-dimensional media were also performed which replicated the preferential flow and ponding observed in the laboratory experiments.

## **2.0 Tasks of Water Infiltration and Intermittent Flow Experiments**

This paper presents the continuation of the water infiltration experiments conducted by Geller and Pruess (1995). Flow visualization experiments were conducted on transparent replicas of rough-walled fractures that were inclined at different angles to study the interplay between the gravity and capillary forces. In order to understand the mechanism causing the intermittent flow observed in the experiments presented in this paper and in the experiments conducted by Geller and Pruess (1995), parallel plates with a series of three different apertures were assembled using glass and lucite plates.

The intermittent flow behavior is believed to be caused by water flowing through a series of three different apertures: a “medium”, “coarse”, and “fine” aperture (see figure 1). The rationale for intermittent flow being caused by this particular pore structure can be explained as follows. Water will advance under gravity in the top portion until it encounters the capillary barrier immediately before the middle section. A thread should form in the middle section after the water overcomes this capillary barrier. The bottom section has a high capillary force due to the fine aperture, and if this force is great enough, it could pull the water out of the middle section and cause the thread of water to break.

### **3.0 Apparatus and Experimental Procedure**

#### *3.1 Water Infiltration Experiments*

Water infiltration experiments were conducted using two different transparent replicas of fractured granite rocks from the Stripa mine in Sweden. These replicas will be referred to as Stripa 1 and Stripa 2. The procedure for producing these transparent replicas was originally developed by Gentier (1986) and later modified by Persoff (1994). A mold of each side of the natural rock was made using Rhodorsil RTV silicone rubber, creating a “negative” of the fractured rock surface. Non-hardening modeling clay was used to build a wall around the edges of the mold, and then Ecobond 27 clear epoxy was slowly poured into the mold to make the replica of the “positive” surface of the fracture. The silicone rubber and epoxy both came in two liquid parts, which were mixed together vigorously. The mixing process caused air bubbles to become entrained in the liquid; therefore, the mixture was de-aired before pouring by placing it in a vacuum for approximately 15 minutes. Both the silicone rubber and epoxy were allowed to cure overnight at room temperature. The replicas were machined to a dimension of 21.5 cm wide by 33 cm long. A more detailed description of the procedure for producing the fracture replicas can be found in the appendix.

A photograph of the set-up for the experiment using Stripa 1 is shown in figure 2. The fracture replica was sandwiched between two sheets of lucite that were also 21.5 cm by 33 cm and the replica and lucite were placed inside a specially designed metal frame.

Six bolts were used to hold the entire assembly together. Two clamps were also placed on both sides of the frame near the inlet. A capillary siphon using felt supplied water to the fracture inlet. The felt rested against another piece of felt that was placed inside an inlet groove 19 cm long and 0.5 cm wide to provide an even distribution of water into the system. Another piece of felt was clamped to the outlet to drain water out of the fracture and was placed in an effluent tank to collect the water. The fracture was inclined using lab jacks, and the entire assembly was placed over a light table. Photographs of the flow visualization experiments were taken using a Nikon 35 mm camera.

The set-up for the experiments using Stripa 2 was slightly modified, and the schematic set-up for these experiments is shown in figure 3. The differences in the set-up included placing the fracture over a light table which was already inclined, the two clamps were not placed near the inlet of the fracture, and a groove was not milled at the inlet. A small strip of felt about 5 cm long was still placed across the inlet, however. Stripa 1 was inclined to an angle of  $20^\circ$ , and the Stripa 2 was inclined to an angle of  $34^\circ$  in the experiments.

### *3.2 Parallel Plate Experiments*

Parallel plate experiments were conducted to investigate the mechanism of the intermittent flow observed in the fracture replicas. The plates were assembled with a medium, coarse, and fine aperture distribution. Four parallel plate experiments were conducted using either lucite plates or glass plates.

Experiment 1 was conducted using 0.3 cm thick lucite plates that were 3.81 cm wide and 15.24 cm long. Small strips of aluminum foil were placed on either side of the 6.35 cm long top section creating an aperture of 0.05 mm. The middle portion was 2.54 cm long and was milled to a spacing of 0.5 mm. Filter paper was placed inside the entire third section to draw the water out of this system. The two lucite plates were sandwiched between small blocks of lexan and held together using clamps. The entire assembly was then tilted to an angle of  $30^\circ$ . Water was introduced into this system by means of a capillary siphon using felt that was placed from a beaker of water to the inlet. Another

small strip of felt covered the entire inlet (3.81 cm long). The pressure head at the inlet for this experiments was -1.2 cm. A photograph of this assembly is shown in figure 4.

Experiments 2-4 were performed using 0.3 cm thick window pane glass. These experiments were conducted in order to examine the same mechanism on a slightly larger scale than the experiment using the lucite plates. Glass was used instead of lucite since the contact angle of water on glass is  $0^\circ$  which more closely matches the contact angle of water on rocks such as granite. The glass plates were assembled with the configuration shown in figure 5. One plate was assembled by gluing together three sections of glass along the edges using silicone. Each section had a width of 21.6 cm and when glued together had an overall length of 33 cm. The top, middle, and bottom section lengths were 8.89 cm, 7.62 cm, and 16.51 cm, respectively. Thin strips of shims were placed on either side of the three sections to create the appropriate apertures before the three sections were glued together. The apertures used were 0.25 mm, 0.6 mm, and 0.1 mm for the top, middle, and bottom sections, respectively. The mate of this three section plate was a flat glass plate with a dimension of 21.6 cm by 33 cm.

The set-up for these experiments was essentially the same as the one used for the water infiltration experiment using Stripa 2, which is shown in figure 3. The glass plates were sandwiched between two lucite plates and loaded in the same metal frame used in the infiltration experiments. The six bolts were tightened until they were finger tight. Filter paper was placed inside the last 2-3 cm of the bottom section in experiments 2 and 3 and into an effluent tank located beneath the outlet. In experiment 4, the filter paper was placed inside the entire third section, similar to the experiments using the lucite plates. A capillary siphon using felt was placed at the inlet, creating a pressure head ranging between -0.75 and -1.2 cm at the inlet for the four experiments. A piece of felt about 5 cm long was placed at the inlet to introduce water into the system. The felt only covered a portion of the entire width of the plates so that the top section would only become partially saturated. The plates were placed over an inclined light table. The experimental conditions for experiments 1-4 are summarized in table 2.

## 4.0 Results and Discussion

### 4.1 Water Infiltration Experiments

Figure 6 are a series of six photographs taken during the experiment using Stripa 1. This fracture was inclined to an angle of  $19^\circ$ , and the inlet pressure head was -3 cm. Clear water was initially introduced into the fracture, and two main flow channels formed on the left and right sides of the fracture. The clear water was then replaced with water dyed with liquitint (4 ml dye/ 500 ml water). The second photograph in figure 6 was taken three hours after the dye had been introduced into the fracture. The remaining 4 photographs were taken after the water at the inlet was replaced with clear water. The clear water quickly flowed through fast channels which were present only in a portion of the two main flow channels that were formed. Dyed water remained at the edges of the channels, but after approximately half an hour after the clear water was introduced, the dyed water had diffused into the flow channels and only small portions of the dyed water remained at the edges. The last photograph in the series was taken four hours later, and by this time, nearly all of the dyed water was gone. The fast flowing channels may have implications for solute transport since they reduce of the matrix-fracture interaction time.

Intermittent flow behavior was observed in Stripa 1. Figure 7 is a series of four photographs taken while intermittent flow occurred in the fracture. The thread near the bottom of the right channel exhibited intermittent flow. The breaking and reforming of this thread occurred on the order of several seconds, and then the flow became steady again. The intermittent flow pattern was very repetitive. Each time this behavior was observed, the same section of the flow channel broke and reformed again.

In the experiment using Stripa 2, intermittent behavior was also observed. The fracture was titled to an angle of  $30^\circ$ , and the inlet pressure head was -1.5 cm. Photographs taken during this experiment are shown in figures 8 and 9. Clear water was first introduced into the fracture, and one main channel initially formed. After a couple hours, the clear water was replaced with dyed water (4 ml dye/ 500 ml water). The dyed water immediately traveled through the main channel (see figure 8), and then diffused out forming a "halo" around the main channel. Nine minutes after the dye was added to the



water, another channel formed. After six more minutes, multiple channels formed. Intermittent and unsteady flow patterns occurred in these multiple channels. The formation of these multiple channels was not observed in the experiment using Stripa 1.

The felt was removed at the end of the day and placed back at the inlet the following day to investigate a sequential infiltration event. Multiple channels formed several minutes after the felt was placed at the inlet, which can be seen in figure 9. Initially, many of the channels exhibited intermittent flow, but then after about three minutes only one channel on the right had intermittent flow. About an hour later, the channel on the far right was no longer present (see photograph on the right in figure 9), and the channels all appeared steady, except for one portion near the bottom where the water expanded and contracted very quickly. After approximately another hour, no more unsteady behavior was observed. The pressure head level at the inlet was not kept constant throughout this experiment. The change in the head level could have been a factor causing the change from intermittent flow to the steady flow observed several hours later.

Figure 10 is series of photographs of a different experiment conducted using Stripa 2. The fracture was inclined at an angle of  $30^\circ$ , and the pressure head was changed to  $-2.3$  cm. Two main channels formed, and intermittent flow was observed near the bottom of the left channel. The first photograph in figure 10 was taken of the entire flow in the fracture. The remaining five photographs were focused on the portion of the left channel that was exhibiting intermittent flow behavior. The second photograph was taken immediately after the thread had snapped. A finger immediately began to flow through the portion of the flowpath that was no longer present until it finally connected with the pool of water at the bottom. The flow pattern appeared steady again for some time after the thread reformed, and occasionally intermittent flow would occur again.

#### *4.2 Parallel Plates Experiments*

Intermittent flow behavior was successfully reproduced using the lucite plates, and a periodic cycling of this behavior developed. Figure 11 is a series of pictures taken during one of these cycles. The water was dyed with liquitint at a concentration of 4 ml dye/500

ml water. Water quickly saturated the top section after the felt was placed at the inlet. In the middle section, a "finger" about 4 mm thick formed and grew until it reached the filter paper in the third section. The finger slowly began to thin at the top as the water was drawn into the filter paper. After approximately 10 minutes it finally snapped, and another finger began to form immediately after the previous one had snapped. The time scale of this intermittent cycling was very slow compared to the intermittent flow observed in the fractures. The thread that formed in the plates was also thicker than the threads where intermittent flow was observed in the fractures.

Experiment 2 resulted in a steady flow pattern which is shown in figure 12. The water partially saturated the top section several minutes after the felt was placed at the inlet. After a few minutes, enough water had built up in the top section to overcome the capillary barrier between the top and middle section, and a small droplet emerged and flowed down the middle section leaving one thread about 1-2 mm thick in the middle section. The flow remained steady after the initial thread had formed and the bottom section became nearly saturated. The two photographs in figure 12 were taken 30 minutes apart, and nearly the same flow configuration was observed throughout this time period. The thread in the left photograph was slightly thicker at the top than it was 30 minutes later, but this was noticed only after the photograph had been enlarged. The change in the thickness of the thread was not observed while conducting the experiment, however.

Experiment 3 also resulted in steady flow similar to what was produced in experiment 2. The plates were inclined to an angle of  $34^\circ$  and the inlet pressure head was -0.75 cm in this experiment. The left photograph in Figure 13 was the flow pattern produced in experiment 2 and the photograph on the right was taken during experiment 3. The top section again partially filled with water and one thread formed in the middle section. The thread in experiment 3 did not, however, curve as much as the thread in experiment 2. The curvature in the thread in experiment 2 could have been caused by imperfections on the glass or dirt on the glass which had not been completely cleaned off before the experiment.

Intermittent flow was successfully produced in experiment 4. The plates were inclined to an angle of  $48^\circ$  in this experiment. An initial run was made with the filter paper

placed only inside the last 3 cm of the third section as was done in experiments 2 and 3, and the same steady flow configuration was observed. Filter paper was then placed inside the entire third section, which resulted in intermittent flow behavior. The 0.1 mm aperture in the third section was probably too large to create enough capillary force to draw enough water out of the middle to cause the thread to snap.

Figures 14 and 15 are sequential photographs of the intermittent flow produced. Water partially saturated the top section, although to a much lesser extent in this experiment since the angle of inclination was higher. A thread also formed in the top section, but no unsteady or intermittent flow was observed in this thread. The thread that formed in the middle did, however, exhibit intermittent flow. A section of the thread snapped about 1-2 cm above the third section for several minutes (see figure 14), and then occasionally it snapped at the top of the middle section. A new droplet with a tail would form and flow down the middle section and leave a new thread (see figure 15). After this new thread was formed, it would snap again near the bottom of the middle section and eventually it would snap again at the top. Although a cycling of this intermittent flow developed between snapping at the bottom and top, it did not appear to behave periodically. The times when the thread snapped at the top were recorded, but these times varied between a couple of minutes to around ten minutes. The breaking and formation of this thread perhaps went through several different stages before the cycle was repeated. Another factor which may have affected the rate at which the thread snapped was the evaporation of the water. The sides of the plates were not sealed and the thread formed was again only about 1-2 mm thick. The time scale of the intermittent flow in this experiment occurred on the order of several seconds, which was close to what was seen in the fracture replicas.

## 5.0 Conclusions

The laboratory experiments indicate that infiltrating liquid proceeds along preferential flow paths. This behavior would reduce matrix-fracture interactions since the liquid is in contact with only a small portion of the fracture. Note, however, that the

visualization experiments presented in this report were conducted on an impermeable material; therefore, no matrix-fracture interactions exist as they would in a real rock. Intermittent flow was also prevalent in the flow paths which would cause an even further reduction in the matrix-fracture interaction. The frequent occurrence of intermittent flow in these experiments suggests that this behavior may be the rule rather than the exception in unsaturated fractured rocks. Preferential flow paths and intermittent flow both have strong implications on solute transport in fractures. Experiments using parallel plates with special pore structures indicate that intermittent flow may be caused by a series of medium-coarse-fine apertures. Intermittent flow was successfully reproduced in parallel plates experiments using lucite and glass plates with this type of pore structure.

## **6.0 Future Research**

The water infiltration experiments are currently being refined in order to obtain quantitative measurements. Special endcaps used in experiments conducted by Persoff and Pruess (1995) will be used to measure changes in capillary pressure at the inlet of the fracture. Liquid pressure will also be monitored at the inlet and kept constant to observe how changes in this pressure affect the flow patterns observed in the transparent replicas. Flowrates through the fracture will be measured and video equipment will be used to record and analyze the flow patterns in both the water infiltration and parallel plate experiments. Also planned are experiments using real rocks to include matrix-fracture interactions. In order to still permit visualization, the transparent replica will be used for one side of the fracture, and the other side will be the real rock.

Numerical simulation programs currently being used in the Yucca Mountain site characterization project all predict that steady flow will develop for time-independent infiltration boundary conditions. Work is therefore needed to more realistically represent the physical processes which cause intermittent flow in fractures. Understanding the mechanisms will be crucial for upscaling to field conditions and for evaluating the importance of intermittent flow at Yucca Mountain.

## 7.0 Acknowledgments

This work was carried out under U.S. Department of Energy Contract No. DE-AC03-76SF00098 for the Director, Office of Civilian Radioactive Waste Management, Office of External Relations, administered by the Nevada Operations Office, U.S. Department of Energy, in cooperation with the Swiss National Cooperative for the Disposal of Radioactive Waste (NAGRA). I would like to thank my research supervisor, Karsten Pruess, and my research advisor, Feng Wen, for their helpful discussions on this project and comments on this report. I would also like to thank Peter Persoff for advice and discussions on experimental materials, and I would especially like to thank Jil Geller for the enormous help and guidance she has given me on these experiments.

## 8.0 References

- Geller, J. and K. Pruess, On Water Infiltration in Rough-Walled Fractures. Extended Summary, submitted to 1995 International High-Level Radioactive Waste Management Conference, Las Vegas, NV, May 1995.
- Persoff, P. and K. Pruess, Two-Phase Flow Visualization and Relative Permeability Measurement in Natural Rough-Walled Rock Fractures, submitted to *Water Resources Research*, 1995.

## 9.0 Table and Figure Captions

**Table 1:** Experimental conditions for water infiltration experiments

**Table 2:** Dimensions and experimental conditions for the parallel plate experiments

**Figure 1:** Schematic of medium-coarse-fine pore structure causing intermittents flow

**Figure 2:** Apparatus for water infiltration experiment using Stripa 1

**Figure 3:** Schematic of apparatus used for experiments using Stripa 2 and parallel plate experiments

**Figure 4:** Apparatus for parallel plate experiments using lucite plates

**Figure 5:** Cross-section of the glass plates used in the parallel plate experiments

**Figure 6:** Series of photographs taken after clear water was introduced into Stripa 1

**Figure 7:** Photographs of intermittent flow in Stripa 1

**Figure 8:** Formation of multiple channels in Stripa 2

**Figure 9:** Formation of multiple channels in Stripa 2 after a sequential infiltration event

**Figure 10:** Series of photographs taken of intermittent flow in Stripa 2

**Figure 11:** Intermittent flow produced in lucite plates

**Figure 12:** Steady flow pattern produced in the glass plates with a 0.1 mm aperture in the third section

**Figure 13:** Steady flow pattern produced in the glass plates after two different runs with the 0.1 mm aperture in the third section

**Figure 14:** Intermittent flow produced in glass plates with filter paper in the bottom section: thread snapping and reforming near bottom of the middle section

**Figure 15:** Intermittent flow produced in glass plates with filter paper in the bottom section: thread snapped at the top of middle section and reformed

Fracture	inlet h (cm)	angle
Stripa 1	-3	19
Stripa 2		
Exp. 1	-1	30
Exp. 2	-2.3	30

Table 1: Experimental Conditions for Water Infiltration Experiments

Experiment	section of plate	length (cm)	aperture (mm)	inlet h (cm)	angle
1 Lucite Plates	top	6.35	0.05	-1.2	30
	middle	2.54	0.5		
	bottom	6.35	filter paper		
2 Glass Plates	top	8.89	0.25	-1	30
	middle	7.62	0.6		
	bottom	16.51	0.1		
3 Glass Plates	top	8.89	0.25	-0.75	34
	middle	7.62	0.6		
	bottom	16.51	0.1		
4 Glass Plates	top	8.89	0.25	-1.2	48
	middle	7.62	0.6		
	bottom	16.51	filter paper		

Table 2: Dimensions and Experimental Conditions for the Parallel Plate Experiments

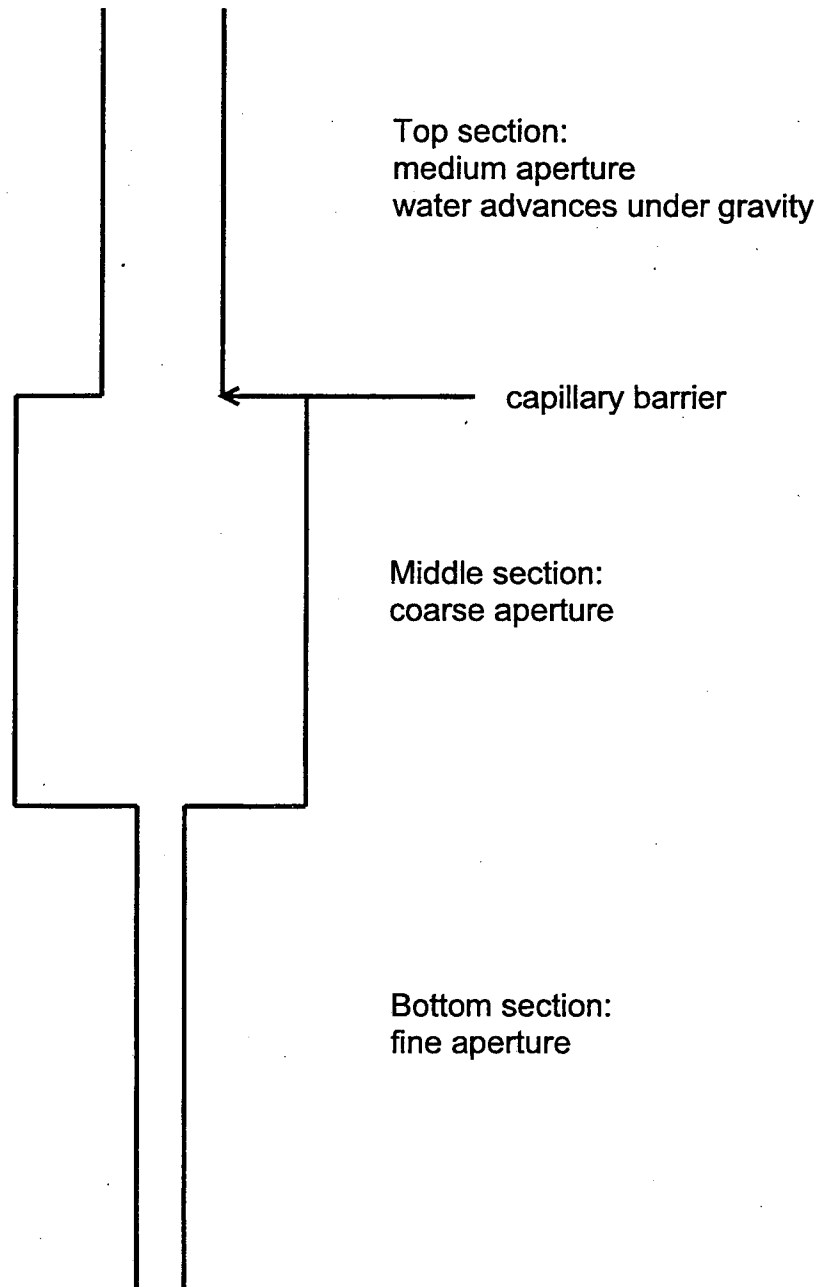

Figure 1: Cross-section of medium-coarse-fine aperture sequence



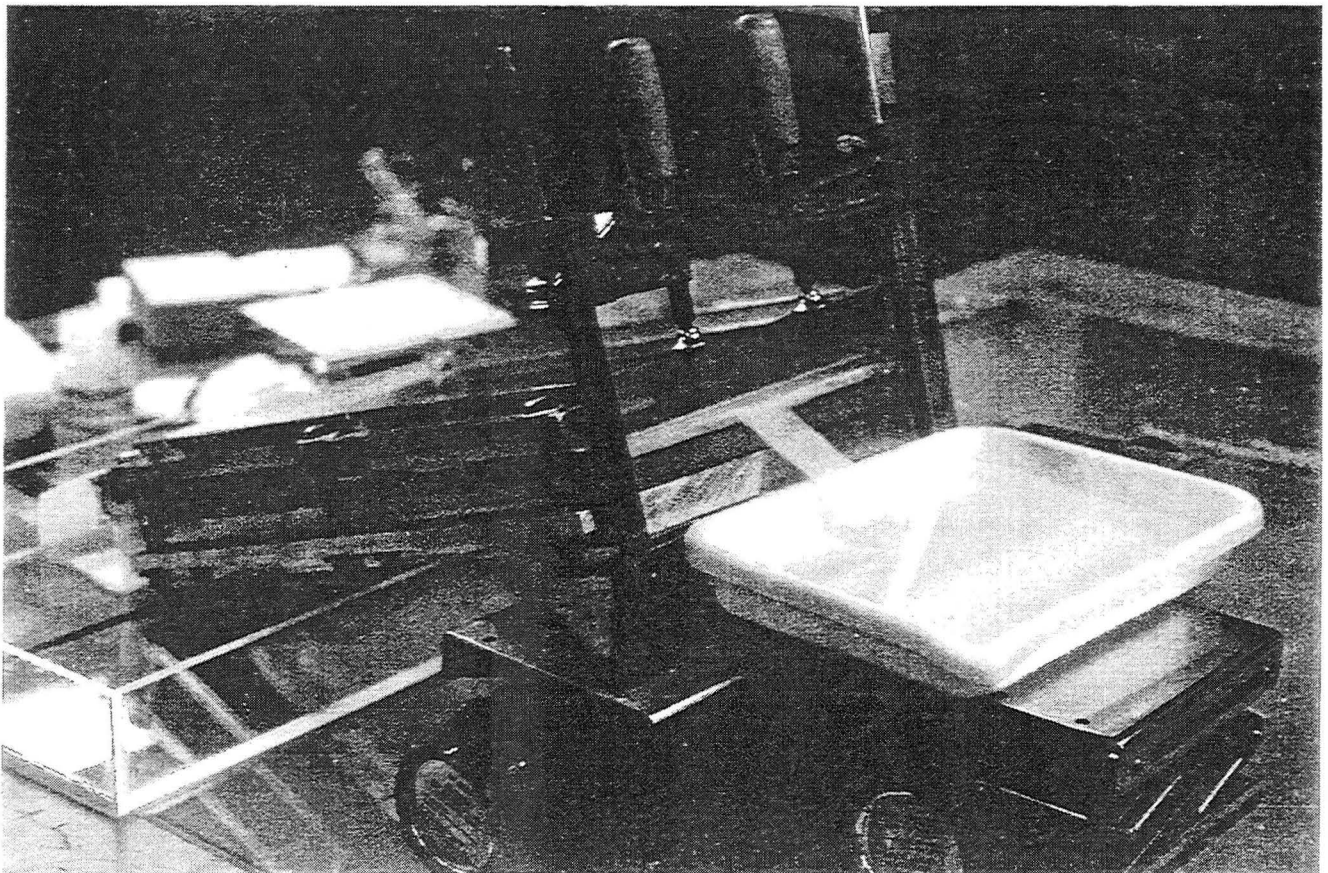
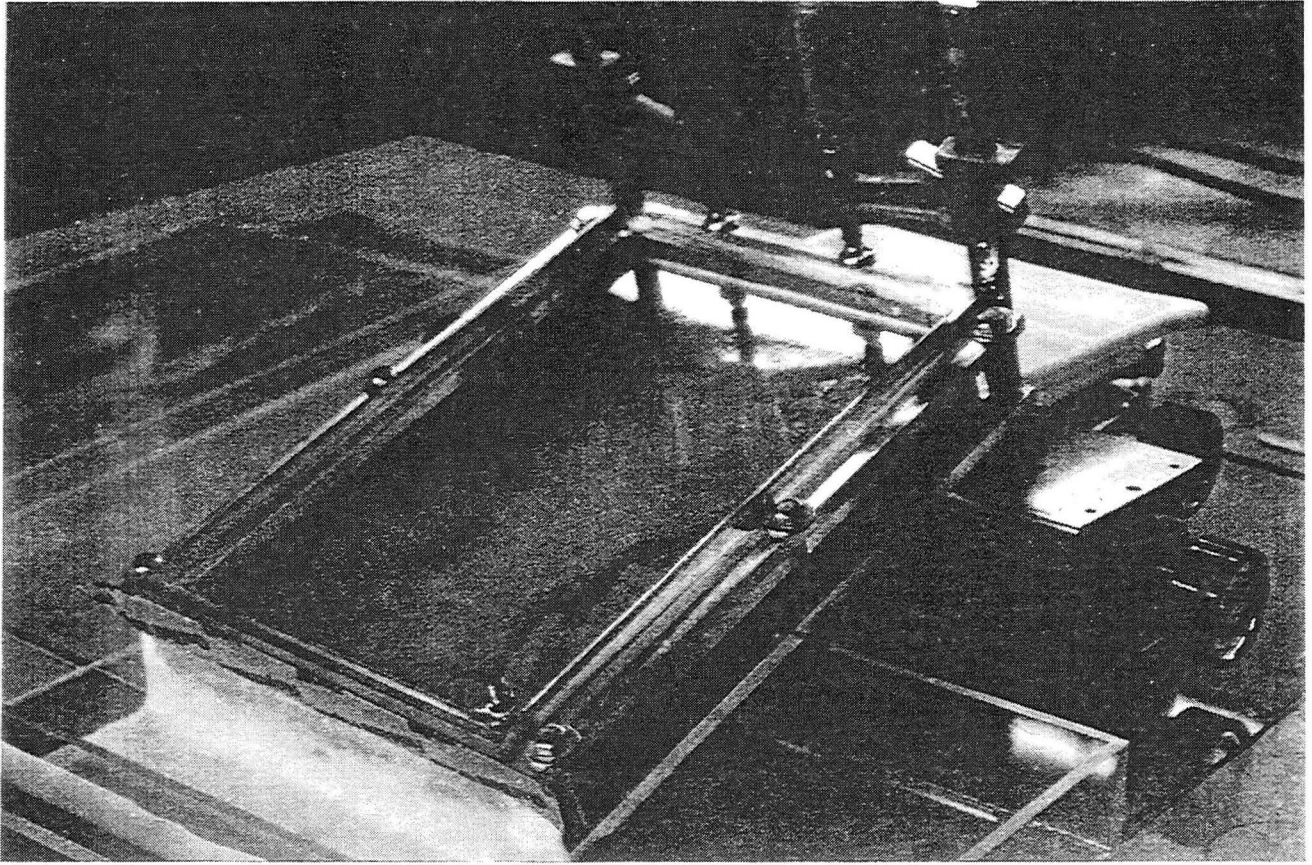

Figure 2

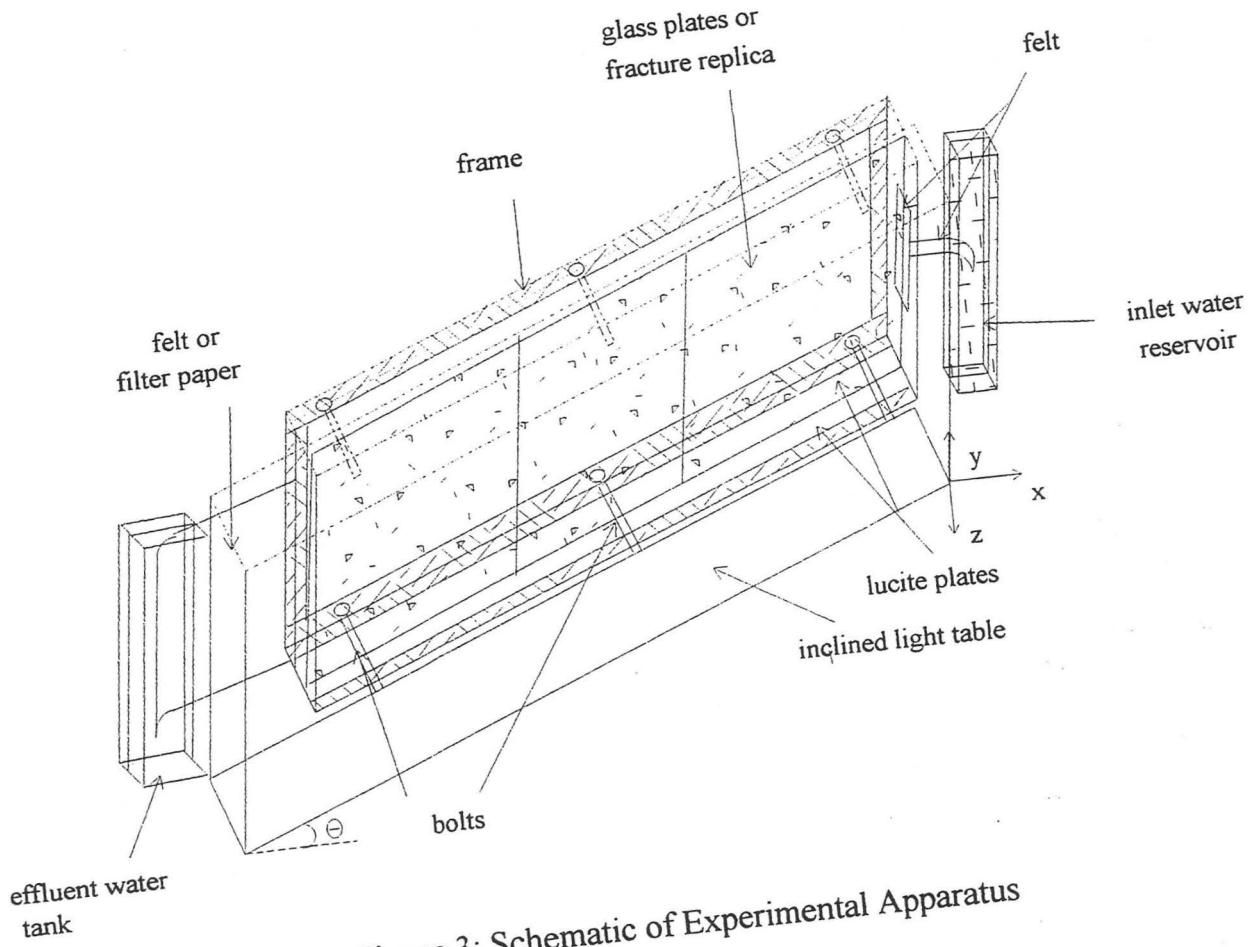

Figure 3: Schematic of Experimental Apparatus

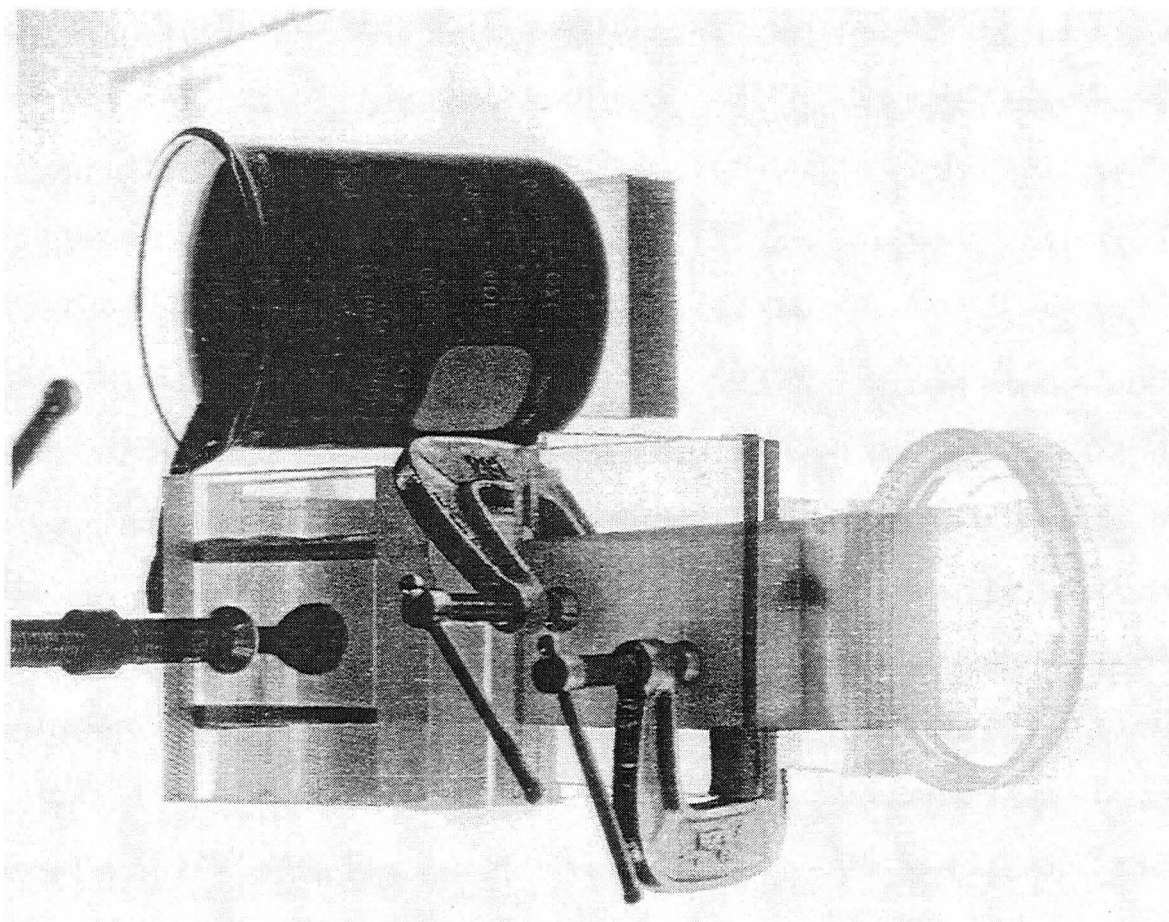

Figure 4

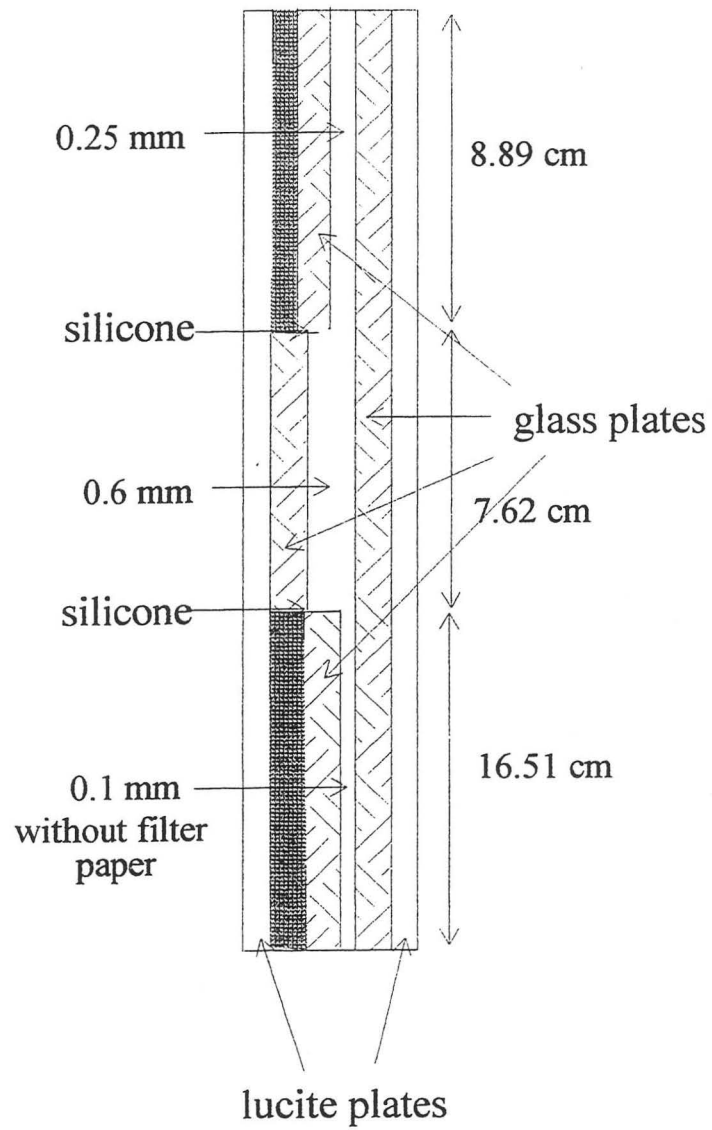

Figure 5: Cross-section of Glass Plates



$\theta=19^\circ$   $h=3.0\text{cm}$



12:00



15:20



15:50



15:56



16:17  
Figure 6



20:15

$\theta = 19^\circ$   $h = -3.0$  cm



13:00-1



13:00-2



13:00-3



13:00-4

Figure 7



$\theta=30^\circ$   $h=1.5\text{cm}$

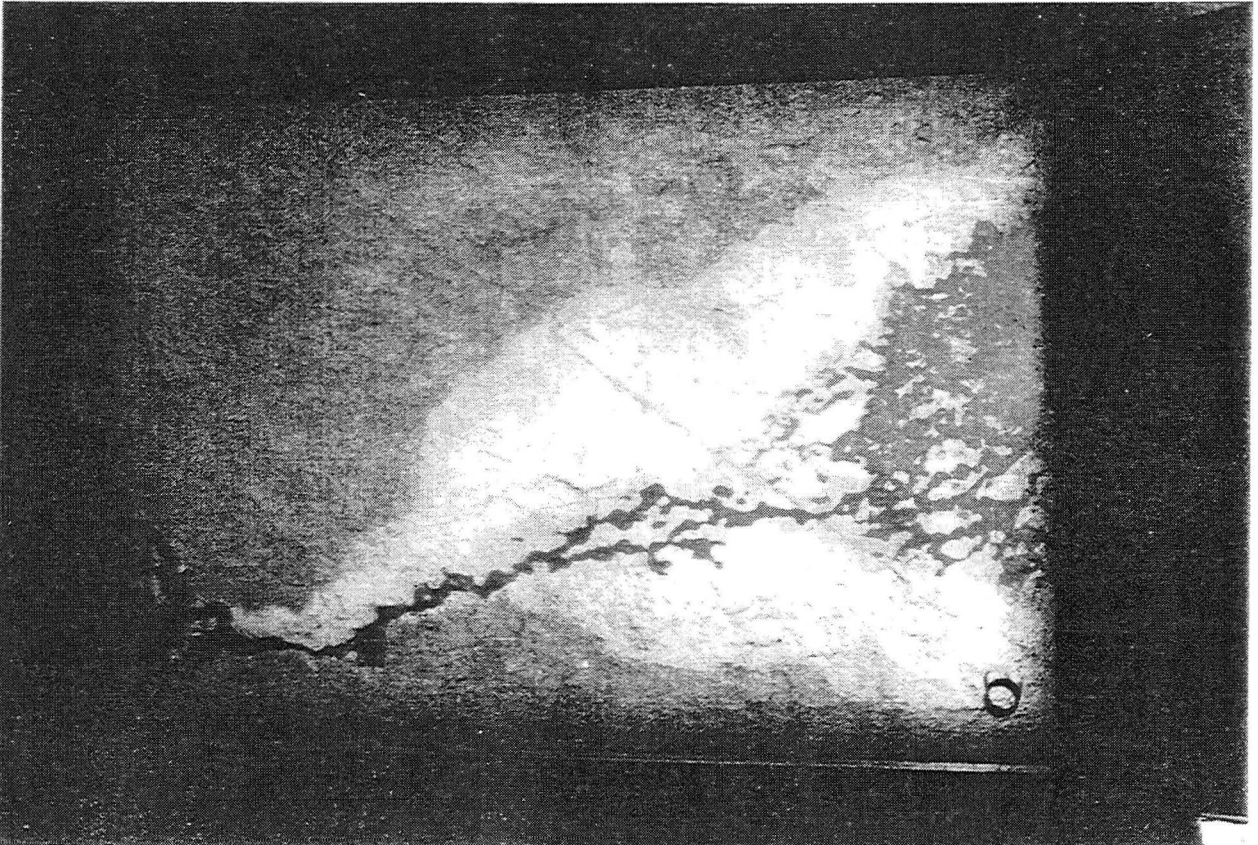

15:31-1

Figure 8

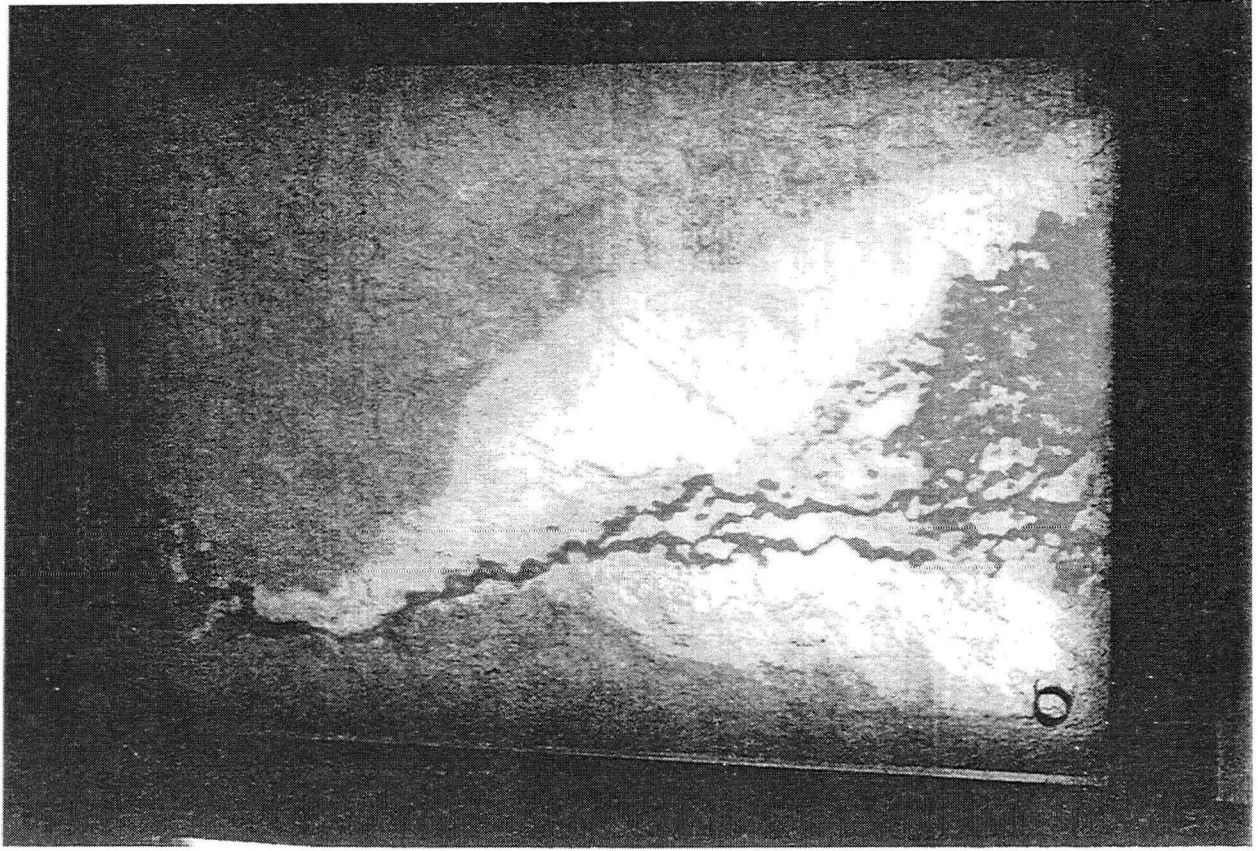

15:31-2

$\theta=30^\circ$   $h=1\text{cm}$

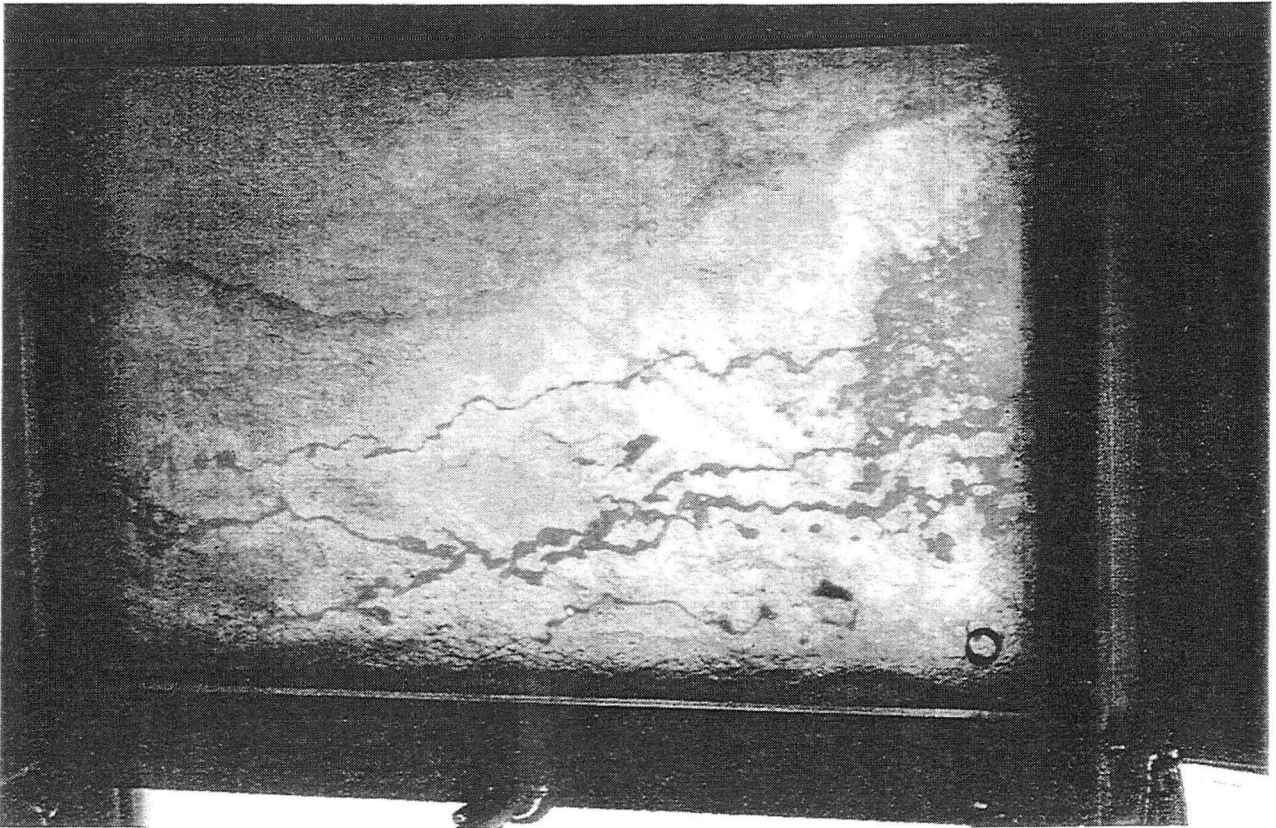

9:43

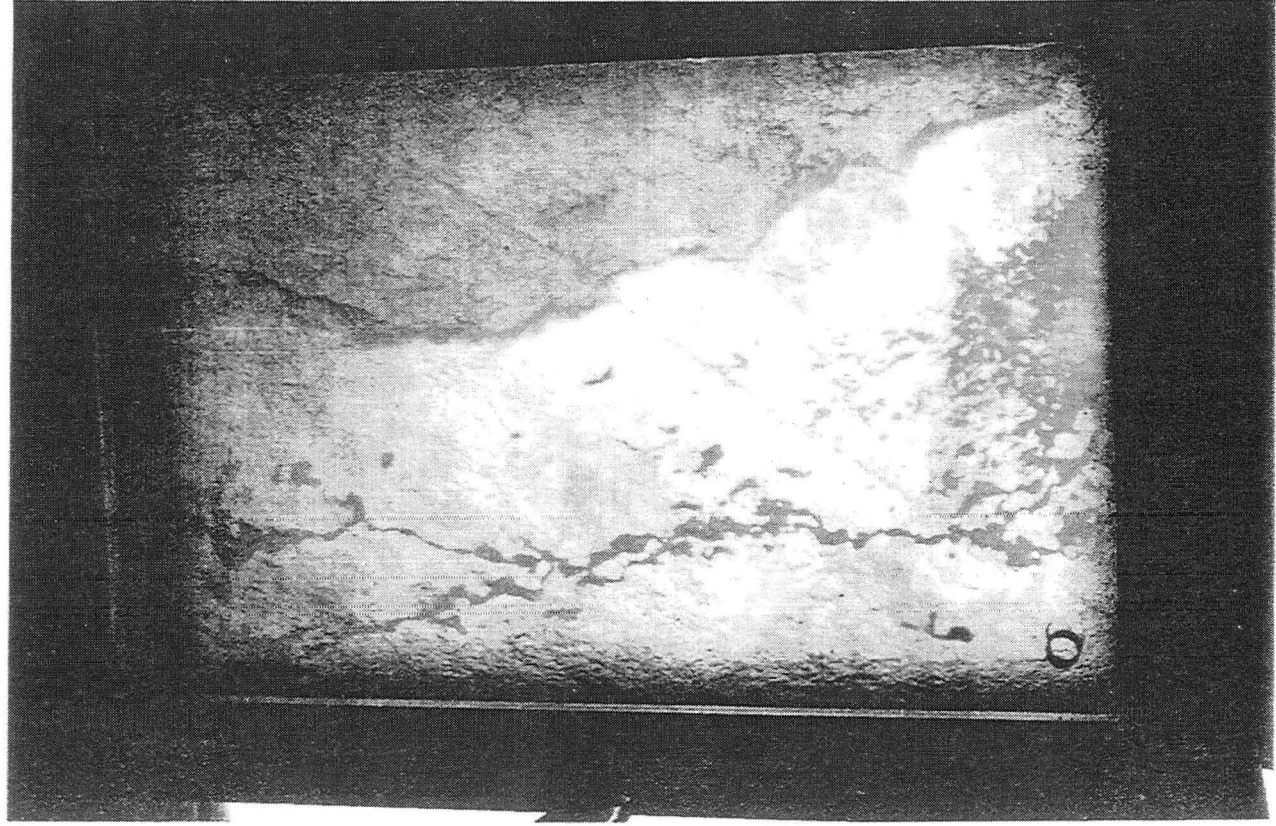

11:05

Figure 9



$\theta=30^\circ$   $h=2.3\text{cm}$



17:40

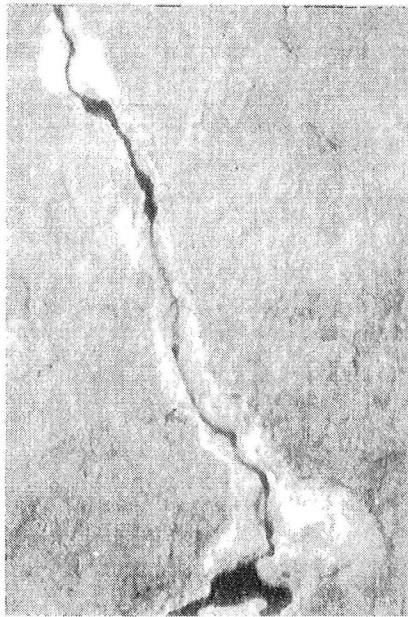

17:45-1

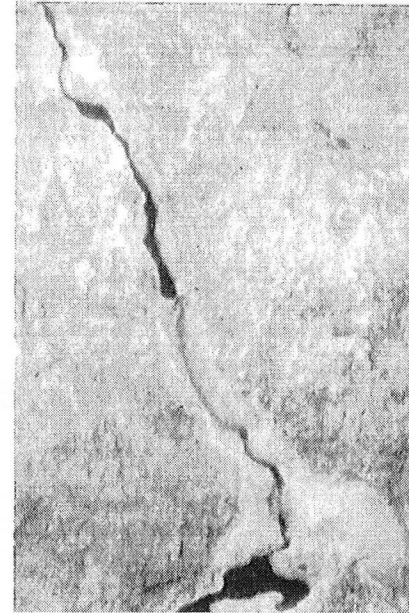

17:45-2



17:45-3

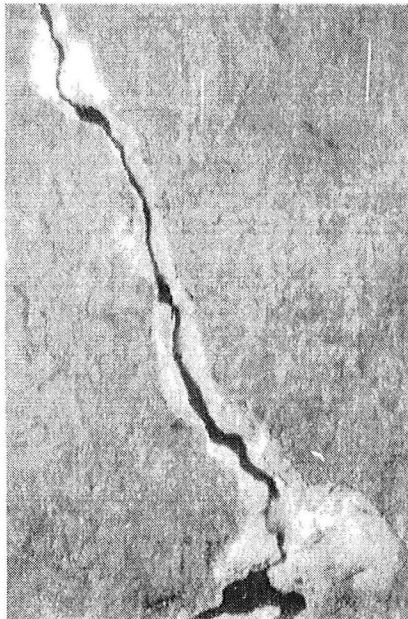

17:45-4  
Figure 10



17:45-5

Lucite Plates  $\theta=30^\circ$   $h_{in}=1.2\text{cm}$   $h_{out}=2.3\text{cm}$

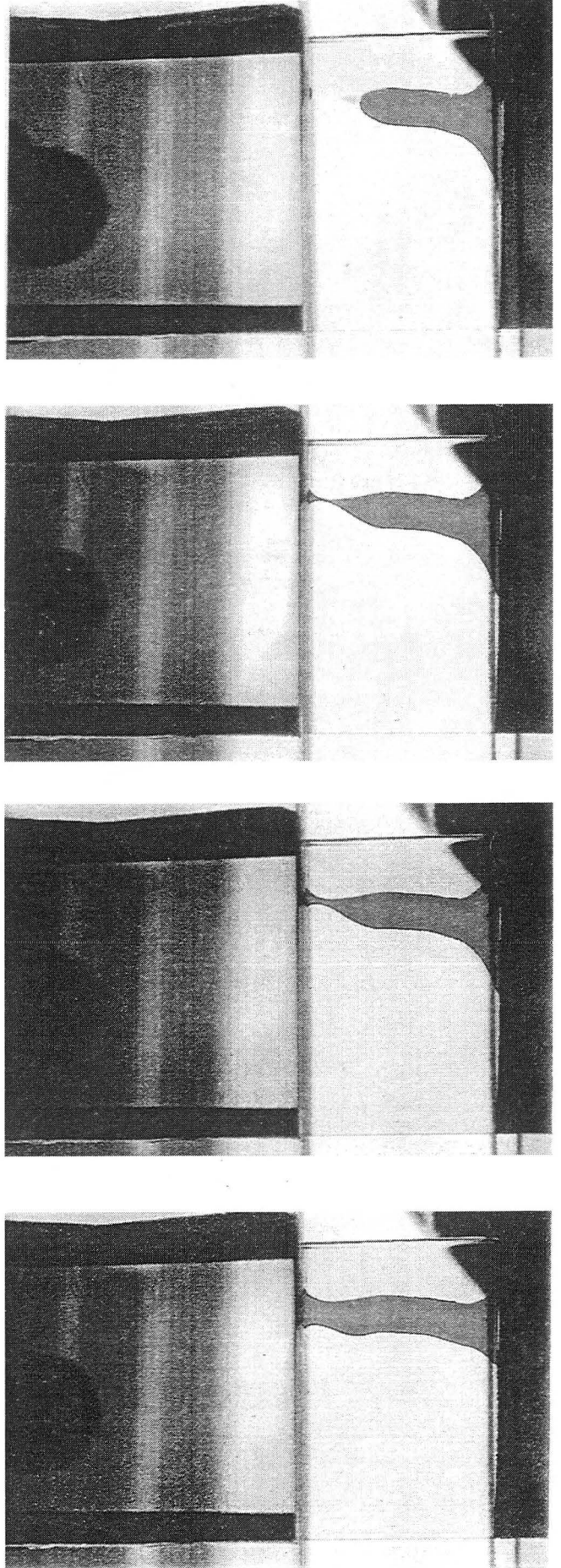
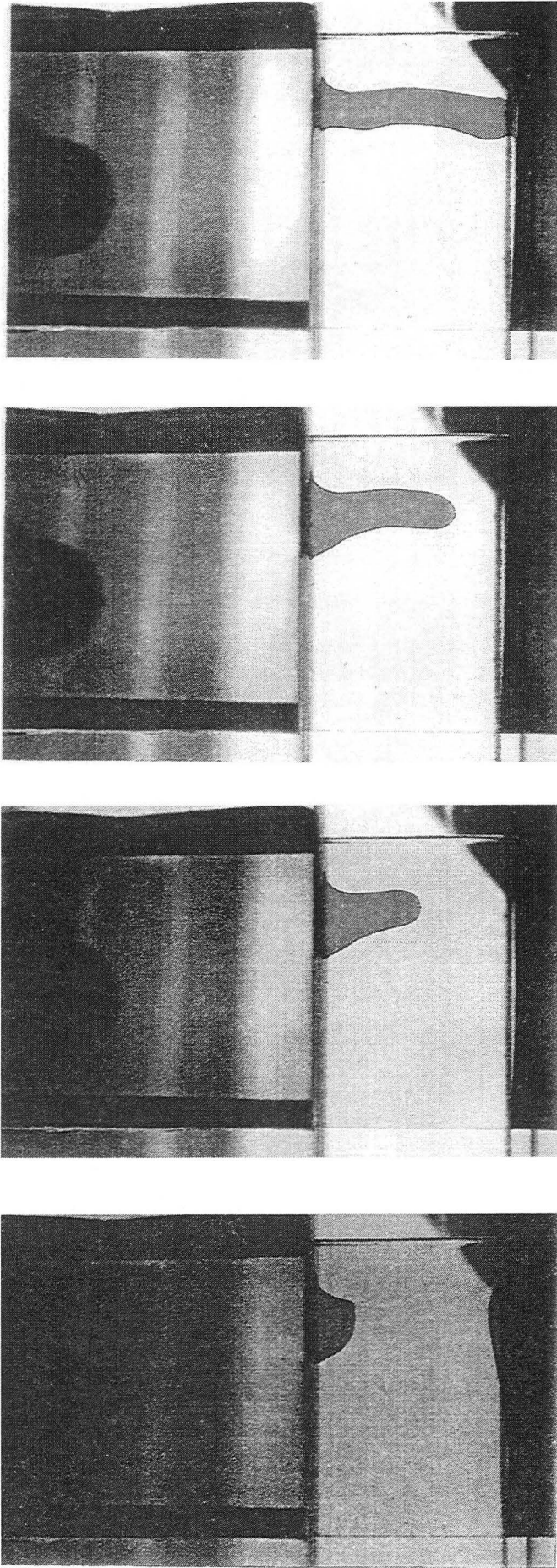
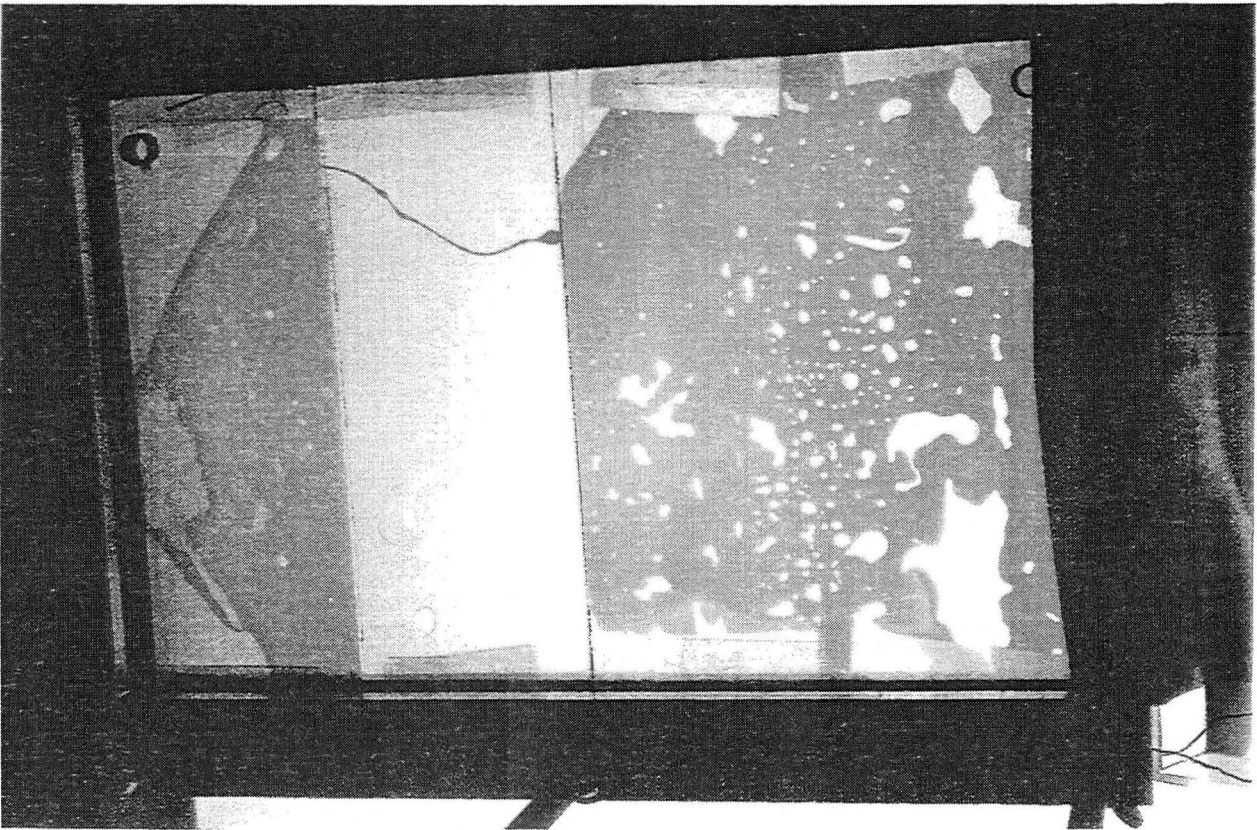

Figure 11



Glass Plates  $\theta=30^\circ$   $h=1\text{cm}$



14:00

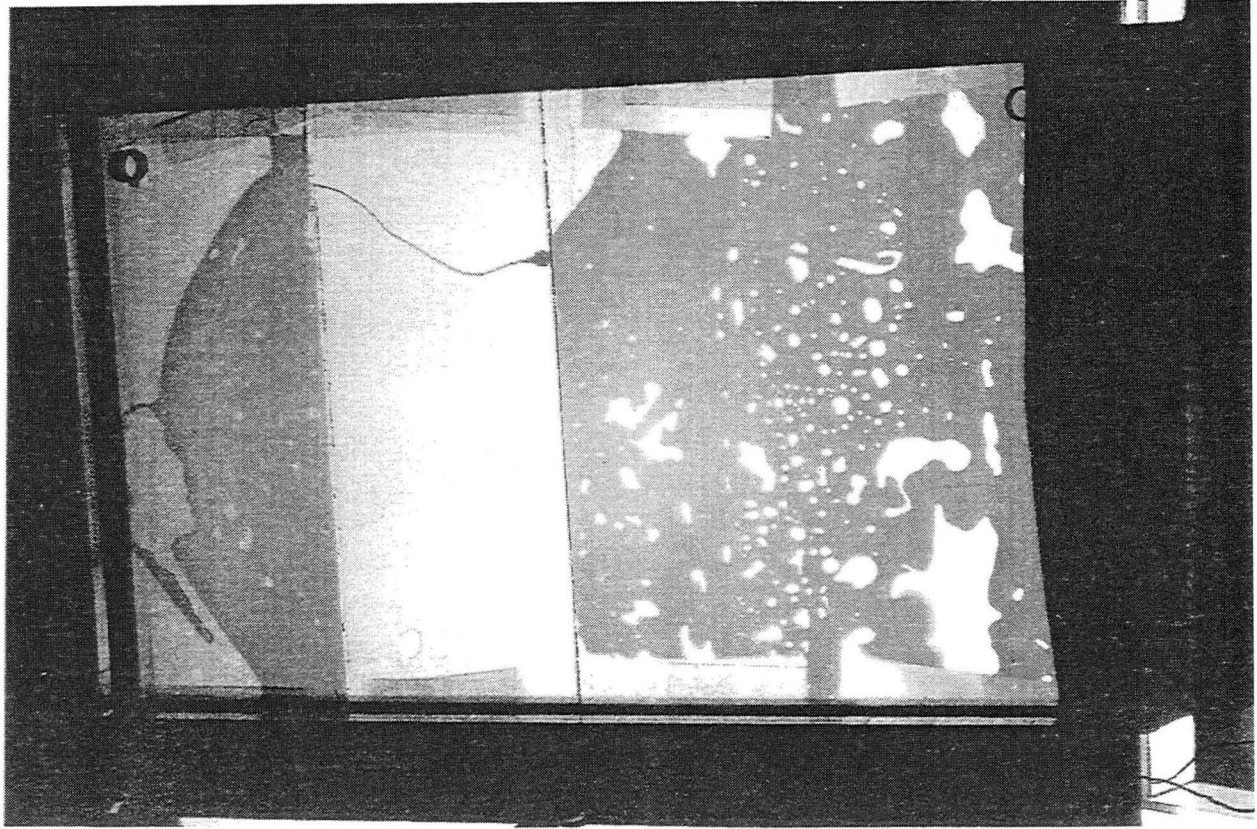

14:30

Figure 12

$\theta=30^\circ$   $h=1\text{cm}$

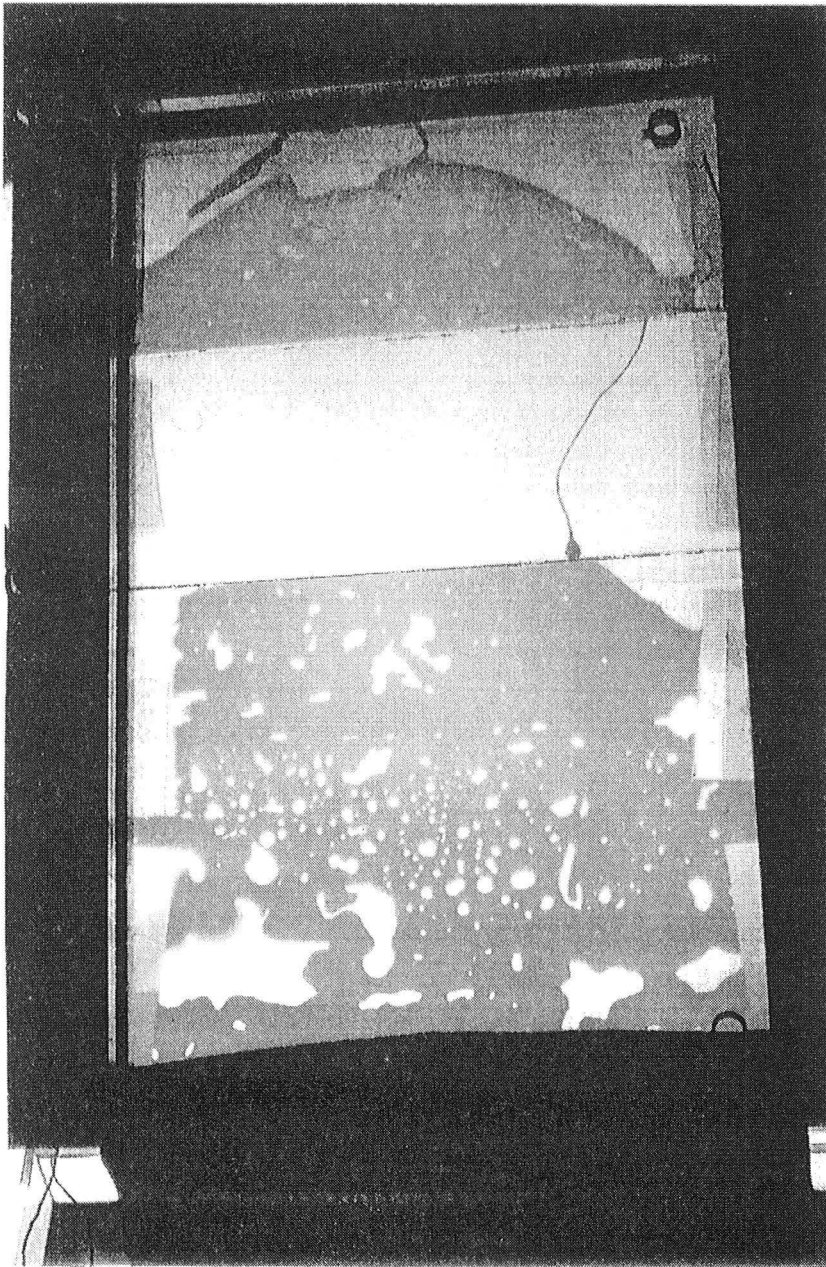

14:30 3-22-95

$\theta=34^\circ$   $h=0.75\text{cm}$

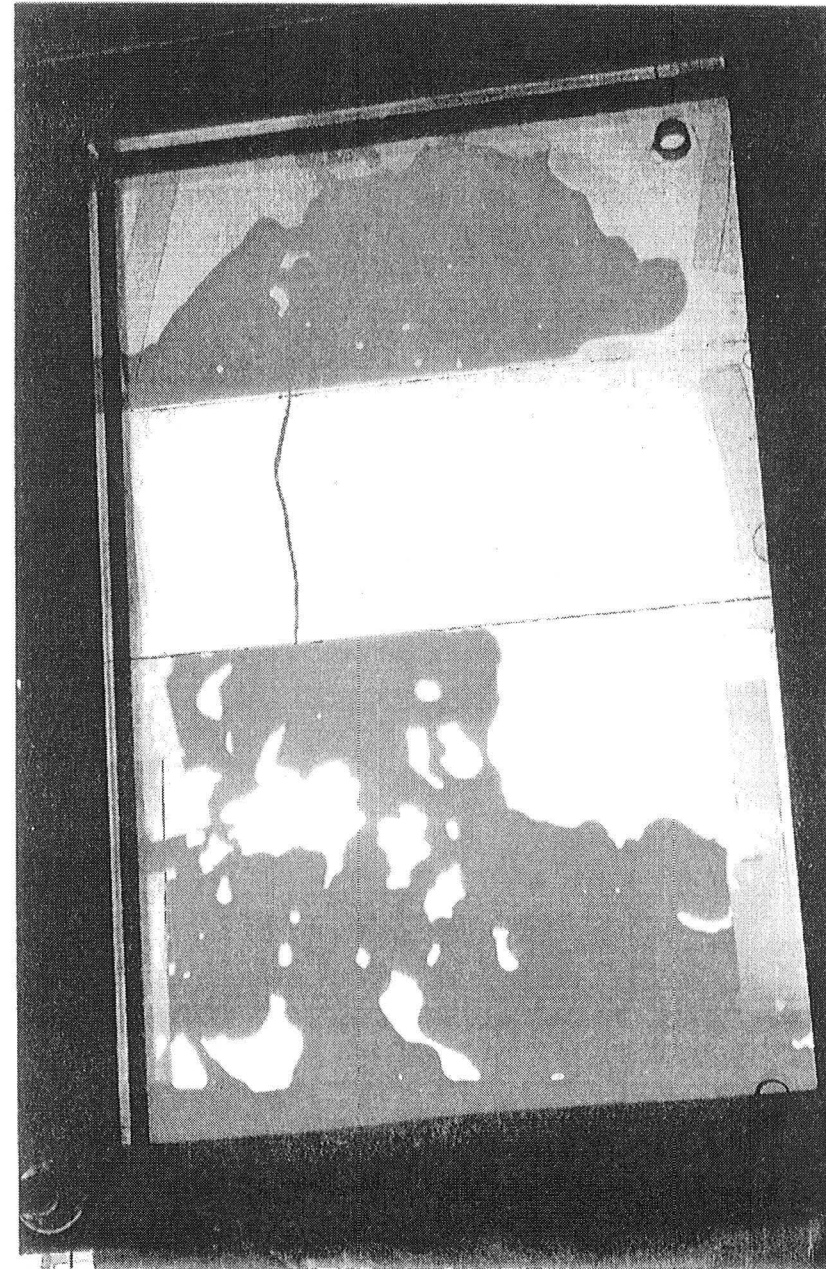

14:45 3-24-95

Figure 13



$\theta=48^\circ$   $h=1.2\text{cm}$

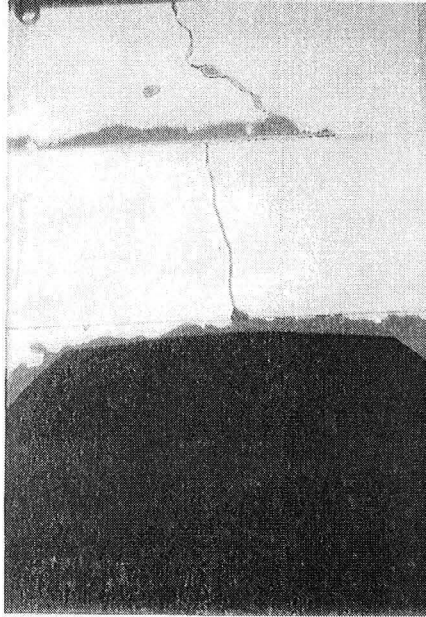

12:04-2

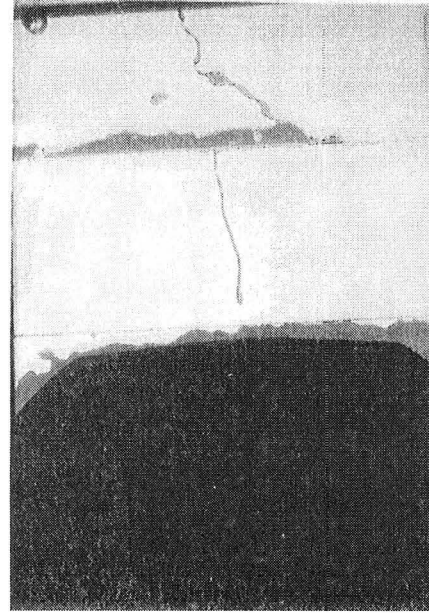

12:04-3

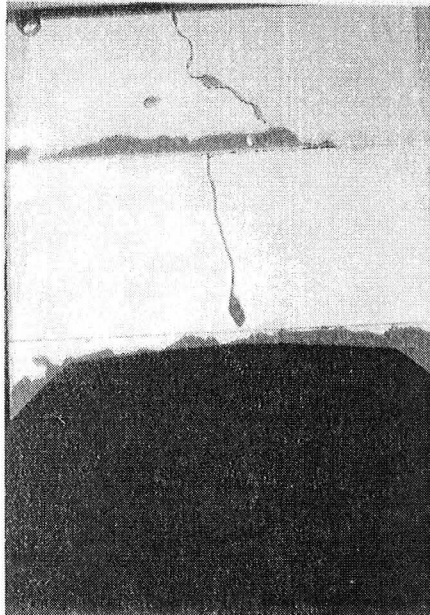

12:04-5

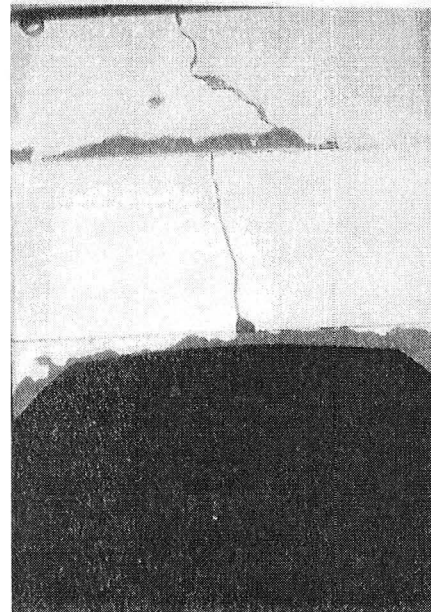

12:04-6

Figure 14

$\theta=48^\circ$   $h=1.2\text{cm}$

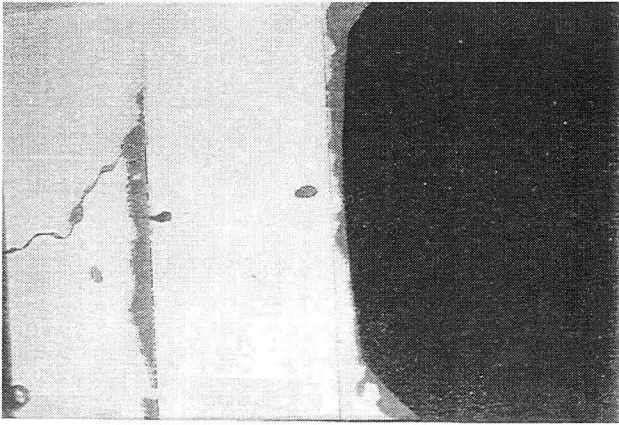

12:11-1

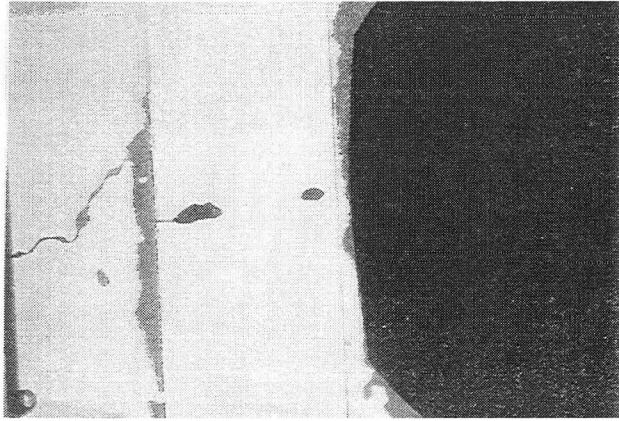

12:11-2

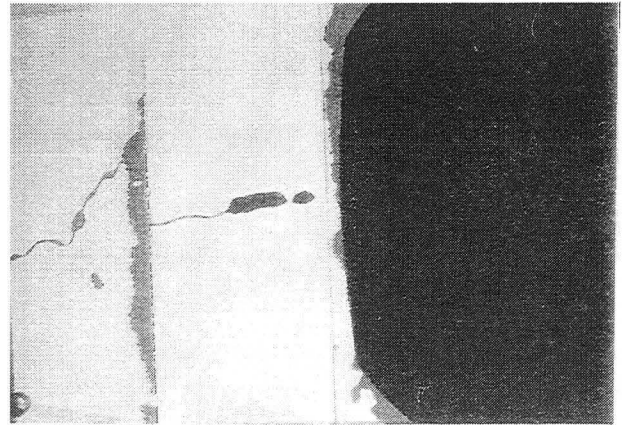

12:11-3

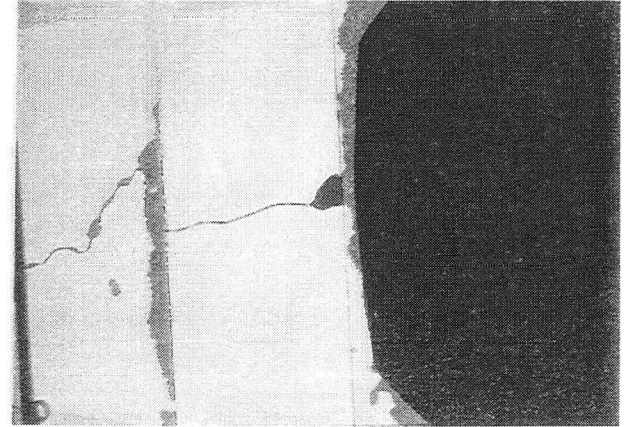

12:11-4

Figure 15

## Appendix

### Procedure used to make Transparent Replicas of Natural Rough-Walled Rocks

#### Fracture Mold

- 1) Cut an aluminum sheet approximately 4 inches wide and long enough to wrap around the rock.
- 2) Fold in one edge of the aluminum sheet about 0.5 inches in toward the rock. Cut the sheet at this 0.5" edge to wrap around any corners of the rock.
- 3) Use duct tape to tape aluminum sheet to the rock. Allow at least 1"-1.5" of the sheet above the fracture.
- 4) Use silicone sealant to seal the edges of the tape. Make sure both top and bottom edges of the tape are covered, along with any edges where the tape overlaps.
- 5) Spray the fracture and aluminum sheet with mold release.
- 6) Vigorously mix Rhodorsil RTV 1556 silicone rubber purchased from Rhone-Poulenc, Inc., Monmouth Junction, NJ with a 10:1 ratio of part A: part B. Place mixture in a vacuum for approximately 15 minutes. Carefully pour mixture onto the fracture, making sure no bubbles form on the surface of the rock. If bubbles do form, place rock with RTV into the vacuum. Pour enough RTV until it is about 1"-1.5" thick.
- 7) Allow the RTV to cure for approximately 24 hours. Remove aluminum sheet and carefully peel off the mold from the fracture.
- 8) Cut the bottom edge of the mold at a slight angle using a razor blade.

#### Fracture Replica

- 1) Used Ecobond 27 epoxy purchased from Emerson and Cuming, Dewey and Almy Chemical Division, W.R. Grace Co., Canton, MA to make the replicas. Mixture comes in two parts: A and B. Vigorously mix the epoxy at a ratio of 3:1 part A: part B. Place mixture in a vacuum for approximately 15 minutes after it starts to foam.
- 2) Slowly pour the epoxy into the mold, making sure no bubbles form. Only pour until the epoxy is about 1 cm thick. Pouring a thicker layer may cause an exothermic reaction which would cause bubbles to form in the epoxy. Allow epoxy to cure at room temperature overnight.
- 3) Continue steps 1 and 2 until the replica is built to the desired thickness (~ 1"). Carefully peel off replica from mold. Machine replica to appropriate dimensions and smooth and polish the surfaces.

**ERNEST ORLANDO LAWRENCE BERKELEY NATIONAL LABORATORY  
ONE CYCLOTRON ROAD | BERKELEY, CALIFORNIA 94720**