

Lawrence Berkeley National Laboratory

Lawrence Berkeley National Laboratory

Title

Half-Scale Model Tests on the Three Quarter Wave R.F. System for the 184-inch Frequency Modulated Cyclotron

Permalink

<https://escholarship.org/uc/item/2sz0x8ts>

Author

Anderson, Robert L.

Publication Date

2010-02-02

Peer reviewed

UCRL -31

Cy.8/73 A

c.2

UNIVERSITY OF
CALIFORNIA

Ernest O. Lawrence

*Radiation
Laboratory*

TWO-WEEK LOAN COPY

*This is a Library Circulating Copy
which may be borrowed for two weeks.
For a personal retention copy, call
Tech. Info. Division, Ext. 5545*

BERKELEY, CALIFORNIA

UCRL-31
c.2

**Special Review of
Declassified Reports**

Authorized by USDOE JK Bratton

Unclassified TWX P182206Z May 79

REPORT PROPERLY DECLASSIFIED

AUG 15 1979

Authorized Derivative Classifier

Date

UNIVERSITY OF CALIFORNIA

RADIATION LABORATORY

~~RESTRICTED~~

Contract No. W-7405-Eng-48

DECLASSIFIED

Half-scale Model Tests on the Three
Quarter Wave R. F. System for the
184-inch Frequency Modulated Cyclotron

by Robert L. Anderson

December 30, 1947

Special Review of Declassified Reports

Authorized by USDOE JK Bratton

Unclassified TWX P182206Z May 79

REPORT PROPERLY DECLASSIFIED

_____	8-15-79
Authorized Classifier	Date
_____	8-20-79
	Date

Berkeley, California

~~RESTRICTED~~

DECLASSIFIED

UCRL - 31
Physics-
Instrumentation

STANDARD DISTRIBUTION

NO. COPIES

Argonne National Laboratory	6
Atomic Energy Commission, Washington	3
Battelle Memorial Institute	1
Brookhaven National Laboratory	6
Carbide & Carbon Chemicals Corp. (K-25 Area)	2
Carbide & Carbon Chemicals Corp. (Y-12 Area)	2
Clinton Laboratories	8
General Electric Company	4
Hanford Engineer Works	2
Iowa State College	1
Los Alamos	3
Madison Square Area	1
Massachusetts Institute of Technology	1
Monsanto Chemical Company, Dayton	1
National Bureau of Standards	2
Patent Advisor	1
Research Division (for NEPA), Oak Ridge	1
Research Division, Oak Ridge, Tenn.	15
University of Rochester	2

Declassification Procedure

Declassification Officer	4
Publications Officer	1
Patent Dept.	2
Atomic Energy Commission (Berkeley)	1
Dr. E. O. Lawrence	1
Information Division	2

total 73

This document contains restricted data within the meaning of the Atomic Energy Act of 1946 and/or information affecting the national defense of the United States within the meaning of the Espionage Act U.S.C. 31 & 32, as amended. Its transmission or the revelation of its contents in any manner to an unauthorized person is prohibited and may result in severe criminal penalty.

ABSTRACT

DECLASSIFIED

Performance curves and test results on a half scale model of the radio frequency system designed to accelerate protons in the Berkeley 184-inch cyclotron are presented. This report is a sequel to K. R. Mackenzie's report on the three quarter wave radio frequency system for frequency modulated cyclotrons.

University of California
Radiation Laboratory
Berkeley, California

Contract No. W-7405-Eng-48

HALF-SCALE MODEL TESTS ON THE THREE QUARTER WAVE R. F. SYSTEM FOR THE 184-INCH FREQUENCY MODULATED CYCLOTRON.

By Robert L. Anderson

for research, development, or manufacturing work.

December 30, 1947

DECLASSIFIED

Half-scale Model Tests on the Three
Quarter Wave R. F. System for the
184-inch Frequency Modulated Cyclotron

by Robert L. Anderson

December 30, 1947

Introduction. The following report is written as a supplement to BP-140, "Preliminary Report on the Three Quarter Wave R. F. System for Frequency Modulated Cyclotrons", by Dr. Kenneth MacKenzie, dated September 12, 1947. Its purpose is to present in detail, the apparatus and the results of tests, including procedure, performed on the half-scale model since September 12, 1947. Further tests will be made on the full size r.f. system prior to its actual installation in the 184-inch cyclotron.

General Description of the Model. The apparatus tested was a half-scale model of the radio frequency system for the acceleration of both protons and deuterons in the 184-inch Berkeley cyclotron. It is shown in its essentials in Figs. 1 through 5 (Reference Drawing # 17335), and in photographs of the model itself.

The dimensions of the model were scaled accurately to the design of the full size equipment which were being prepared at the same time the model tests were under way. Only the radio frequency circuit was simulated in the model, the vacuum system and purely mechanical equipment was not included.

Insulation required for the application of bias voltage to the dee and condenser rotor was not included as it had no radio frequency function. The condenser rotor was arranged to be rotated through accurately indicated angles up to slightly over 30 degrees. A pair of Eimac 304 TL triodes were used in the oscillator in place of the 9C21 triodes planned for the

DECLASSIFIED

full scale unit. It is planned to apply plate voltage to the full scale oscillator only during the acceleration period. Pulsing was not used on the model. In all tests reported the system was driven by its own oscillator. Test Equipment. The instruments used in measuring the results obtained consisted of a General Radio Wavemeter type 724-A, Serial 1498, and seven peak reading probe voltmeters. The latter were designed and made in the laboratory and employed General Electric diodes types 8013-A and 9006, also a miniature Eimac diode. These were calibrated with a Weston Electrical Instrument Corporation precision voltmeter periodically for accuracy, but the errors in readings should be assumed to be \pm 5 to 10 percent.

For power measurements, a Leeds and Northrup optical pyrometer, Cat. #8622-C, was used to observe plate dissipation in the triodes. To calculate efficiency this observed dissipation was then deducted from the total power input. In using the optical pyrometer, one spot on one plate of a triode was selected as the comparison point. The excitation was removed by connecting the plate line to the oscillator housing so that no r.f. currents would flow and all the power input would appear in the plates of the triodes. The pyrometer reading or plate temperature, and the corresponding power input figures were then recorded and put into graphical form. During operation with r.f. currents, the pyrometer readings were taken again, and the amount of actual power dissipated in the plates by referring to the previously recorded figures.

Capacity measurements were made with a General Radio impedance bridge, type 650-A, in conjunction with a R.C.A. oscilloscope.

Frequency Range. Dr. K. MacKenzie's paper gives his calculations for the impedances and lengths of transmission lines used on the model. At that time it was thought that the changes necessary to cover both deuterons and

proton ranges would consist in changing the number of stators from two to four and varying the lengths of the filament and plate lines.

It was found, however, that it would probably be possible to cover both ranges with fixed lengths of lines, and since the front of the dee was so sensitive to impedance change (the insertion of the dummy dee had dropped the upper frequency limit from 48.8 to 44.5 mc, and the lower limit from 19.9 to 18.8 mc), it was decided to make changes in the dee region, if necessary, to broaden either end of the range. To prove the feasibility of this idea, and to demonstrate methods that could be used to raise or lower the frequency limits, two devices (Figs. 6A and 6B) were used. In order to raise the upper limit, a shorted stub -- a section of transmission line less than a quarter wave length at 50 mc -- was connected to each side of the dee. Physically, these stubs were 1 inch diameter inner conductors in 3 inch square troughs, 15 inches in length, and installed 12 inches back from each corner. They raised the frequency from 47 mc to 50 mc, but the power consumption estimate for 40 kv on the final dee increased by 25 percent. Needless to say, it is hoped that use of such stubs on the final system will not be necessary.

The device used to lower the frequency limits consisted of two 4 x 15 inch plates, in contact with the liner and extending into the tank until they were approximately 1/8 inch from the sides of the dee at each corner. Two 1 inch diameter copper pipes attached to the plates and sliding through the dee shield walls served as liner connections for these capacitors. This arrangement added a total of approximately 200 μf to the dee capacity and lowered the frequency from 19.5 mc to 18.5 mc. The extra power consumption was about 5 percent at 19.5 mc, with a very slight difference noticeable at 24 mc.

The importance of raising the upper frequency limit became the prime objective and several changes in the system were made at this time. Three points were vulnerable and most sensitive to change. These were the capacity presented to the dee by the dummy dee, the minimum capacity of the rotor, and the inductance at the throat of the dee. Reducing any one of these would raise the frequency, and since the dummy dee was the worst offender, its dimensions were reduced as much as seemed practical. The changes are shown in Fig. 7. When the unit was replaced the upper frequency limit was found to be 46.7 mc instead of the former 45.8 mc. The lower limit went from 19.4 mc to 19.6 mc without adding any capacity by means of the aforementioned plates.

The next change was in the dee throat. This region is a current maximum point at the highest frequency and most sensitive to volume or inductance. It was found that the clearances between the dee and liner in the model were already less than those in the present deuteron system. Since no change was desired in this region unless necessary, the clearances were reset to the specifications shown in Fig. 8 A. The result was a drop in frequency to check the effect more closely, the clearances were changed from those shown in Fig. 8 A to those in Fig. 8 B. It was found that this change raised the upper frequency limit from 46.2 mc to 47.1 mc. The power consumption was decreased 6.0 percent at 46.2 mc. The power requirement measurements at this stage in the experiments were found to be very inaccurate due to differences in plate capacity on the two 304-TL triodes and the consequent difference in distribution of r.f. currents. However, a subsequent recheck showed the above power consumption figure to be relatively accurate.

The next point of attack was the rotor and stator teeth and efforts to reduce the minimum capacity here were made by revising the dimensions of the

blades and teeth to those shown in Fig. 9. However it had earlier been found necessary to increase the diameter of the rotor shaft for mechanical reasons and little more could be done in this region. The final range with six rows of rotor blades (69 per row), and two rows of stator teeth (72 per row), the modified dummy dee, and full clearance in the dee throat, was from 45.6 to 19.7 mc. without adding any devices to widen the limits. The theoretically required range, full size and doubled for the model, is from 45.8 to 19.6 mc.

It is possible that differences between the full scale equipment and the model may widen the range the additional fraction of a megacycle required. These differences include adding inductance to the dee and condenser support stems outside the tank, and adding two more rotor discs where spaces exist in the model. If the range is still too short, the dee capacity will probably be increased to lower the minimum frequency and shorted stubs attached to the dee for the proton range.

The Transmission Line Oscillator. Up to this point most of the effort had been spent on frequency range experiments and on getting rough measurements of dee voltage response and power requirements. After cleaning up some of the mechanical items such as clearances, rotor dimensions, location of the filament loops, and reducing the dee stem to its minimum length, attention was turned to finding a length of transmission line that would operate satisfactorily from 18.5 mc to 46 mc, permitting the use of a single oscillator for protons and deuterons. The only item that was to be varied was the filament phasing capacity.

Dr. MacKenzie's report gives all the calculations of line lengths for each range, the impedances, and the loop and phase shift requirements. Using these figures as a starting point, the line lengths were adjusted

empirically, keeping several essentials in mind.

1. The dee voltage must be at least twice the d.c. plate voltage.
2. The oscillator must be stable enough to sustain an arc drawn from the dee face (simulating discharges in that region).
3. The r.f. voltage on the plates of the triodes should not be excessive.
4. The phasing capacity, as calculated in MacKenzie's report (BP 140, p. 20 - 23), should be as near $\mu\mu\text{f}$ as possible.

It was found that the system could be made to work over both ranges with various combinations of line lengths; but the shorter the filament line on the model, the larger the filament grid capacity could be made. It is evident that the r.f. current path and the impedances in the filament line are changed radically as it enters the vacuum system. Also, the inductance inherent in the 304-TL triodes is large compared with that in the 9C21 triodes to be used in the final oscillator.

The performance with one combination of line lengths is shown in Fig. 10, where the length of the filament line was 69 inches and the plate line 116 inches, with a phasing capacity of about 200 $\mu\mu\text{f}$. In contrast, Fig. 11 shows the performance with a combination of a 40 inch filament line and a 130 inch plate line. The phasing capacity in this case was increased to approximately 300 $\mu\mu\text{f}$. Both the above capacity estimates are for the deuteron range. For protons the capacities were about 100 $\mu\mu\text{f}$ and 200 $\mu\mu\text{f}$ in the two cases respectively. With a short filament line the capacity used was less critical, the discharge stability was better, and the plate line could be made longer. The latter was desirable for deuterons because it improved the ratio of dee to plate voltage. The maximum length of plate line was limited by the appearance of a resonant condition in it that would

cause a dip in the dee voltage response. This dip became progressively worse as the line was made longer. A length was selected that would give a comparatively flat dee voltage response. A deviation of an inch or two one way or the other will cause this response to rise or fall at either end of the range.

Choke Coils. In determining the proper size for choke coils for the oscillator filament heating current it was found that the original ones used were resonant at 18 mc, which may account for a sharp drop observed in the dee voltage as this frequency was approached. The coils were rewound and made resonant at 60 mc after which the voltage drop was no longer noticed at the low frequency.

Capacity Measurements. Some capacity measurements were made using a General Radio impedance bridge and R.C.A. oscilloscope. The following results were obtained after the dee tie rods and the stub to liner connections were removed, the rotor being connected to liner.

Stub to liner capacity, rotor varied.	Maximum 3315 μmf .
	Minimum 700 μmf .
Dee to liner capacity, rotor varied.	Maximum 4250 μmf .
	Minimum 1590 μmf .

With the rotor removed:

Stub to liner capacity 585 μmf .
Dee to liner capacity 1500 μmf .

The following apparent condenser capacity can be calculated from the above.

Stub to rotor.	Maximum 3315 - 585 = 2730 μmf
	Minimum 700 - 585 = 115 μmf
Dee to rotor	Maximum 4250 - 1500 = 2750 μmf
	Minimum 1590 - 1500 = 90 μmf

Stub to rotor and dee to rotor being in series

$$\text{Maximum apparent capacity across condenser} = \frac{1}{\frac{1}{2730} + \frac{1}{2750}} = 1370 \mu\text{f.}$$

$$\text{Minimum capacity across condenser} = \frac{1}{\frac{1}{115} + \frac{1}{90}} = 50 \mu\text{f.}$$

$$\text{Ratio } \frac{\text{Max-capacity}}{\text{Min-capacity}} = \frac{1370}{50} = 27.6$$

Dee to liner capacity with capacity added to dee edge for deuterons (18.5 mc) = approximately 1650 $\mu\text{f.}$

The dee to liner capacity before the dee stem and the side liners were installed was 770 μf including the original dummy dee.

Power Requirements. Power requirements and plate dissipation were estimated to be as follows:

- 18.5 mc Power input 520 w for 1500 volts on the dee.
Power output 320 w for 1500 volts on the dee.
Efficiency 61 percent.
- 24 mc Power input 470 w for 1500 volts on the dee.
Power output 280 w for 1500 volts on the dee.
Efficiency 59 percent
- 30 mc Power input 520 w for 1500 volts on the dee.
Power output 300 w for 1500 volts on the dee.
Efficiency 59 percent.
- 45 mc Power input 350 w for 1500 volts on the dee.
Power output 223 w for 1500 volts on the dee.
Efficiency 64 percent.

For 30 kv on the full scale system the above power input figures become 146 kw at 9.25 mc, 132 kw at 12 mc, 146 kw at 15 mc, and 98 kw at 23 mc for continuous operation. The stubs and capitors added to the dee to increase the frequency range do cause more power to be consumed, but they also reduce the duty cycle for pulsed operation to such an extent (Figure 12)

that it might be advantageous to use them whether needed or not.

The Frequency Time Curve. The curves of Fig. 12 show the variation of frequency with time or rotor angle. Curve A, corresponds to the case in which nothing is added to increase the frequency range. Curve B shows the variation with capacity added to lower the frequency, while C indicates an estimate of the result of adding shorted stubs to raise the frequency. Only one row of teeth was used on each condenser stator.

From curve C the proton acceleration occurs over 5.0° or 8.3 percent of the cycle, while from curve B the deuteron acceleration occurs over 8.2° or 13.6 percent of the cycle. The oscillator pulsing equipment would be adjusted to apply plate power only over these periods in each cycle.

Voltage Distribution. Fig. 13 shows the variation of voltage with frequency at several key points in the model over both deuteron and proton ranges. No attempt was made to raise the upper frequency, but capacity was added to the dee to attain 18.5 mc. These curves were made from data obtained while holding the d.c. plate voltage constant on the triodes instead of maintaining a constant r.f. voltage potential on the dee.

Conclusion. The results of these tests on the half-scale model show that the required frequency range may be covered on the full scale machine. If necessary the deuteron limit can be lowered by adding capacity to the dee. One of three things can be done to raise the upper proton limit, i.e., reduce the dimensions of the dee throat clearance, increase the dummy dee clearance, or insert stubs at the corners of the dee.

The transmission lines can be empirically adjusted to cover both proton and deuteron ranges without change, leaving only the phasing or

grid to filament capacity as the variable.

The power requirements are no greater than anticipated.

Performance of the model is considered sufficiently satisfactory to proceed with the full scale design and construction based on the model dimensions.

This work was done by J. Franck, J. Reidel and R. L. Anderson under the direction of Dr. K. MacKenzie, at the Radiation Laboratory, University of California under Contract No. W-7405-Eng-48 with the United States Atomic Energy Commission.

cb - 1/19/48
Information Div.

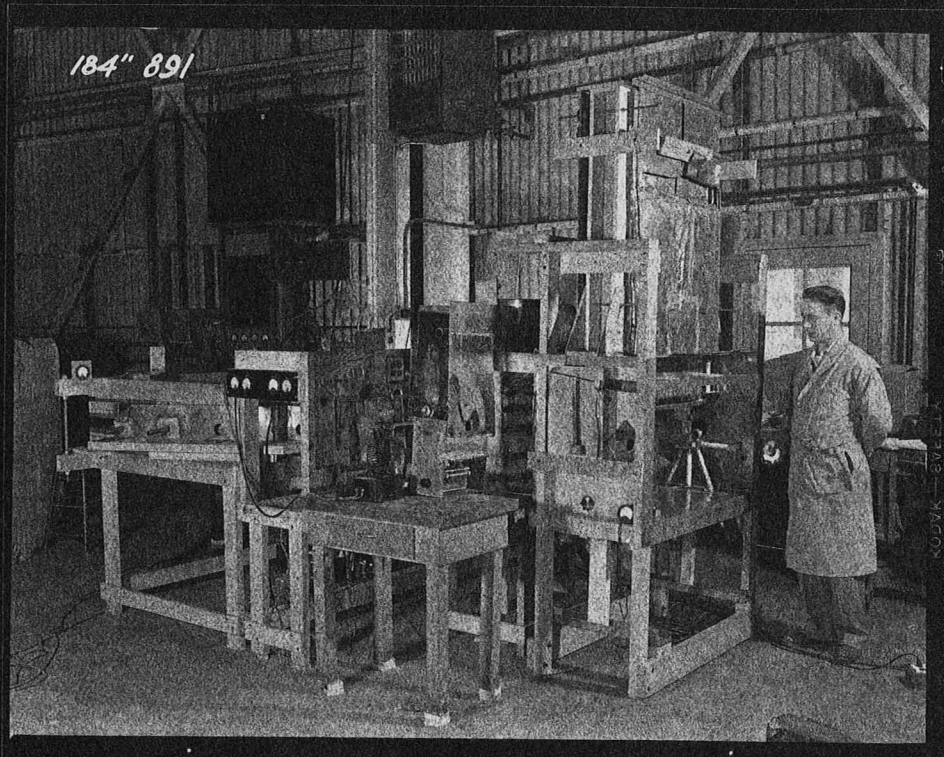

General view of the model

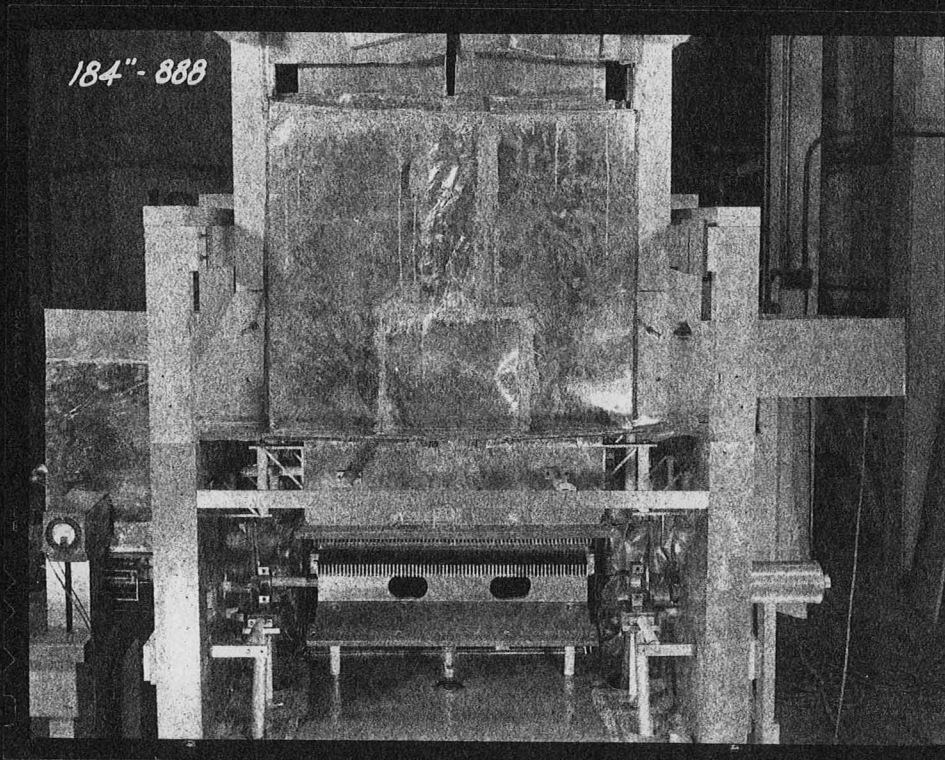

Stub and dee stem with rotor removed. The rotor shaft housing is shown on the right side.

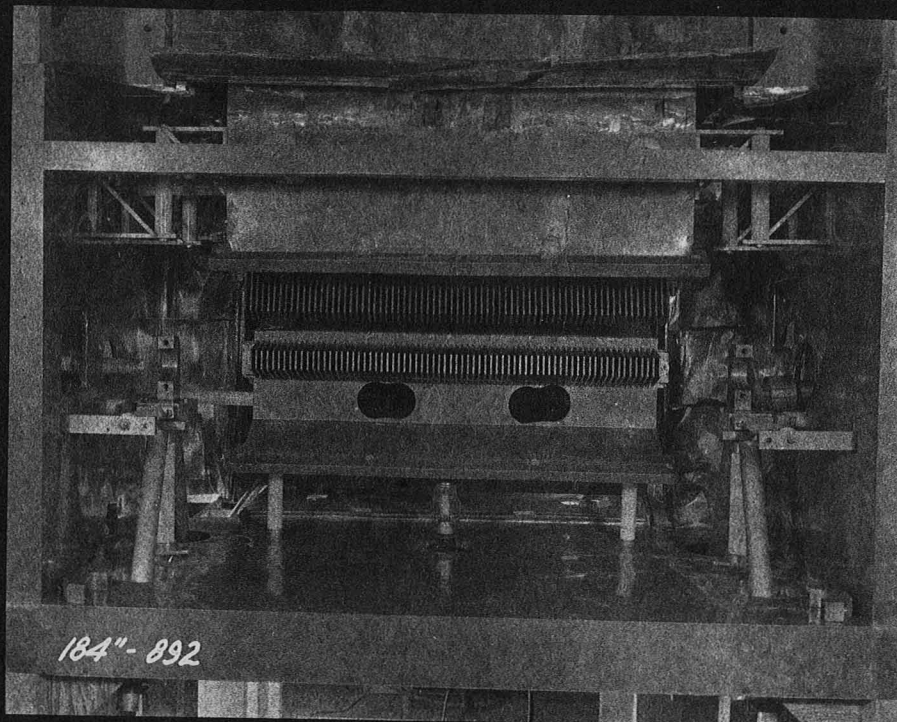

184"- 892

Rotor housing looking toward the dee, with rotor removed.

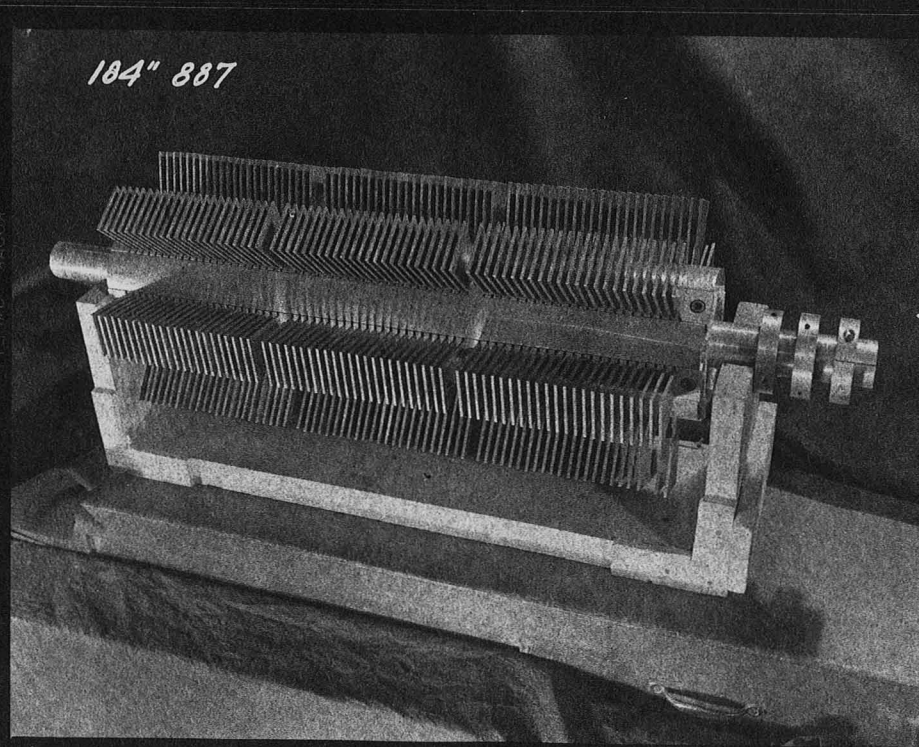

184" 887

The rotor of the variable capacitor.

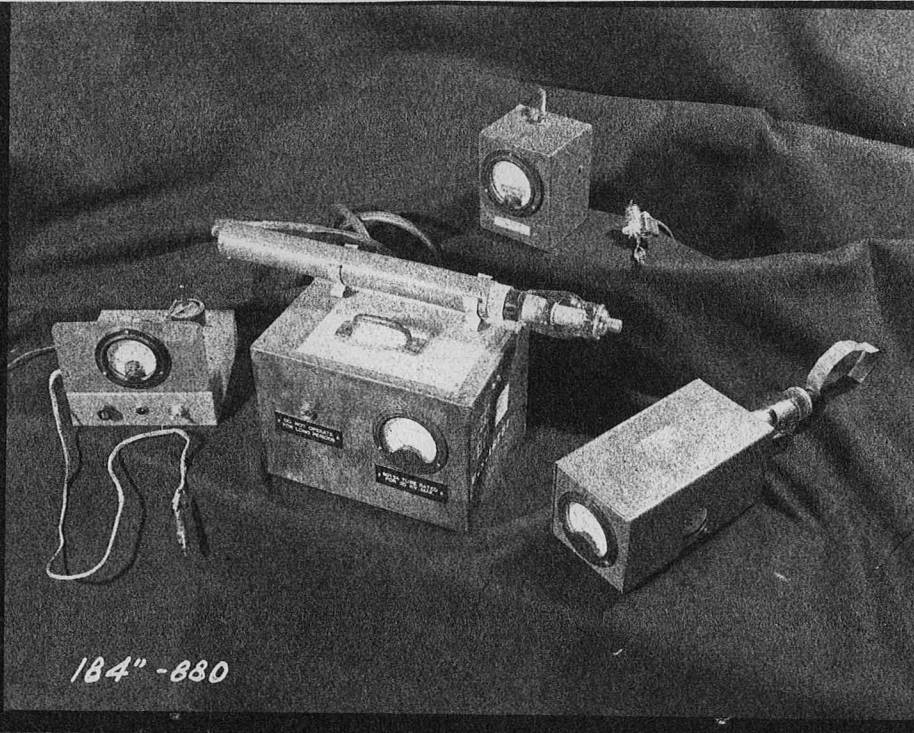

Types of instruments used for voltage reading.

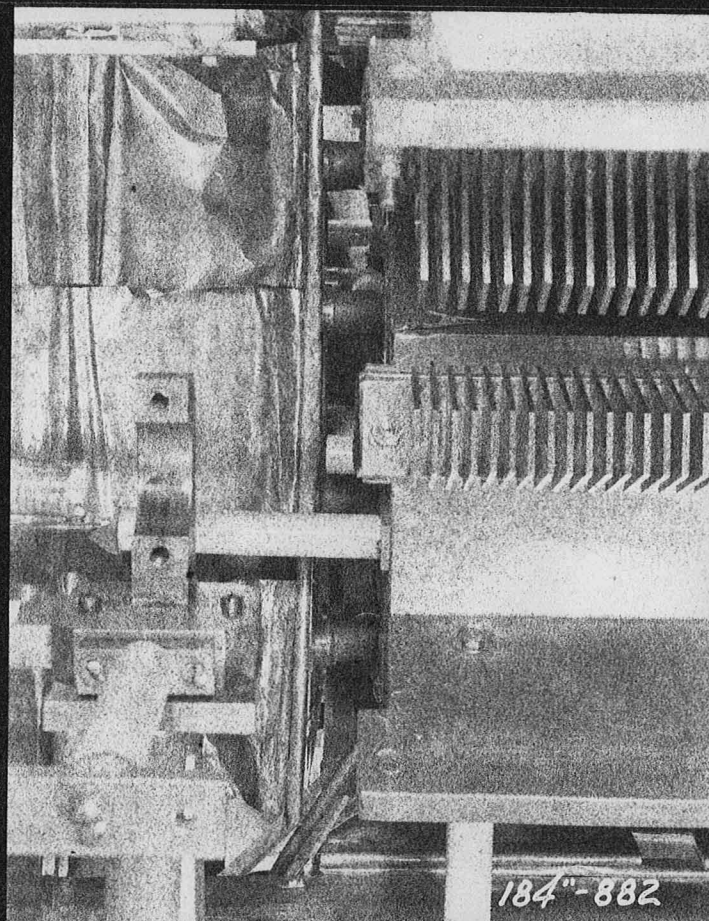

Filament loops inside the tank liner seen through the space between the condenser stators and the liner.

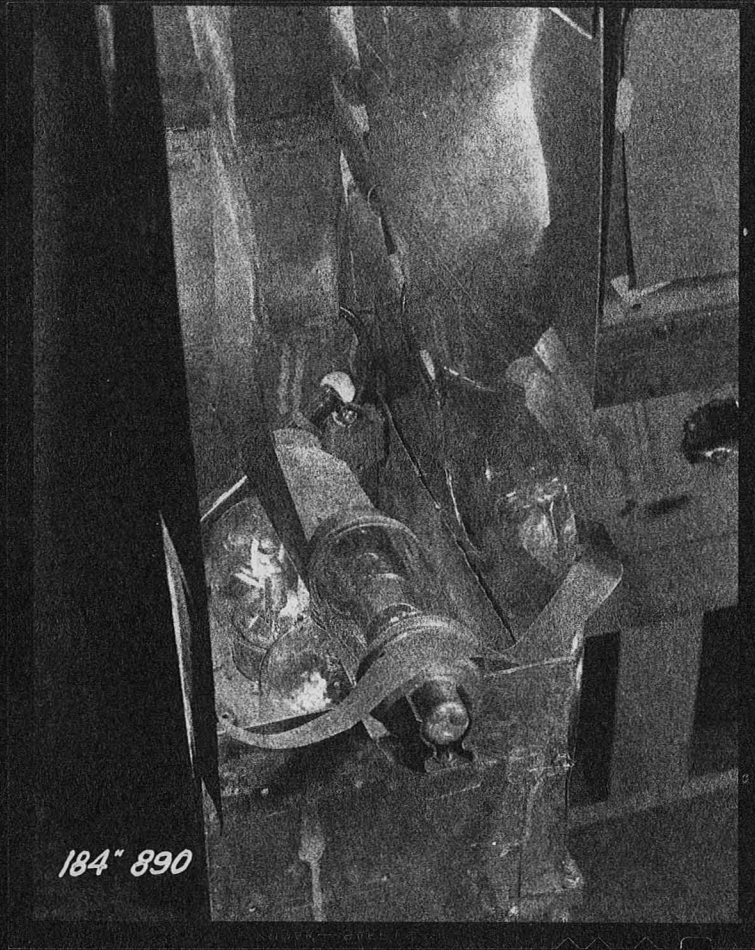

184" 890

The oscillator with vacuum capacitor on the plates of the 304TL triodes.

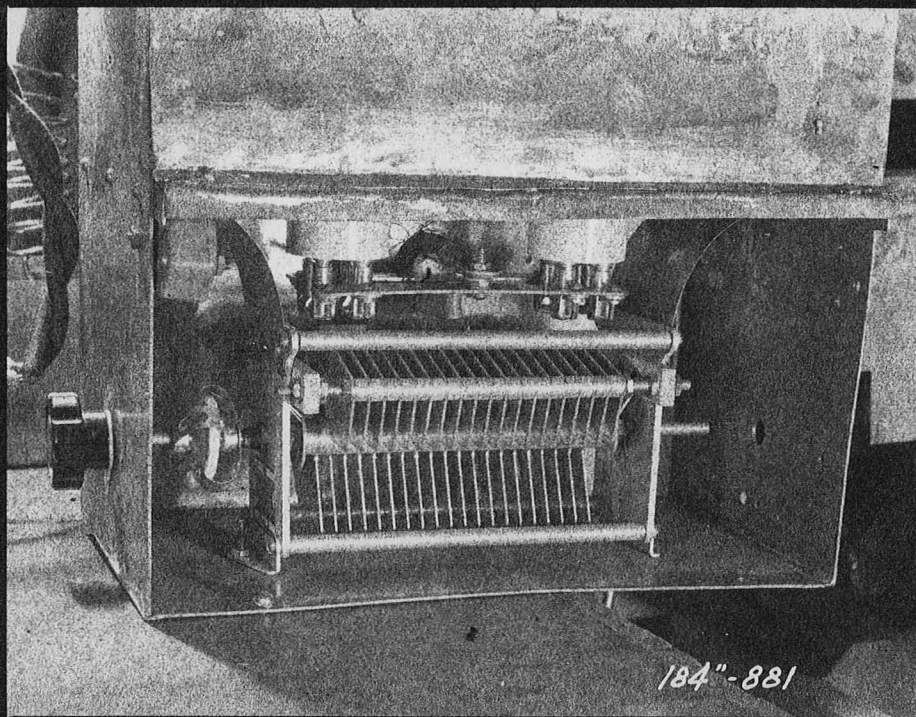

184"-881

Filament phasing capacitor

General view of the oscillator,
filament line, and dee support
insulator, with shield removed.

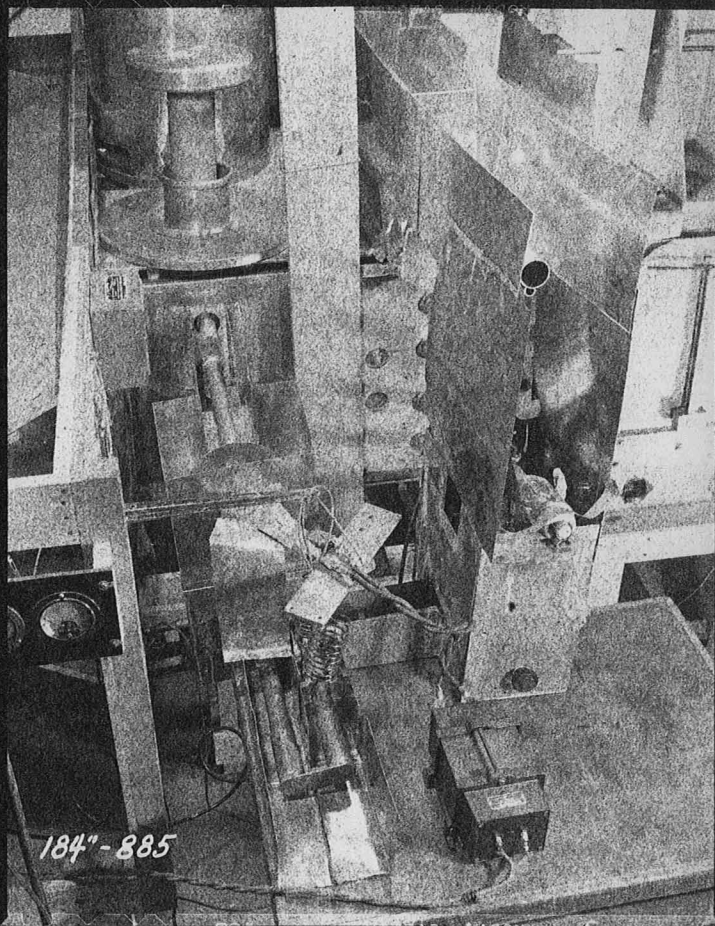

184"-885

Plate transmission line and dee
support insulators. The shield
of one insulator has been removed.

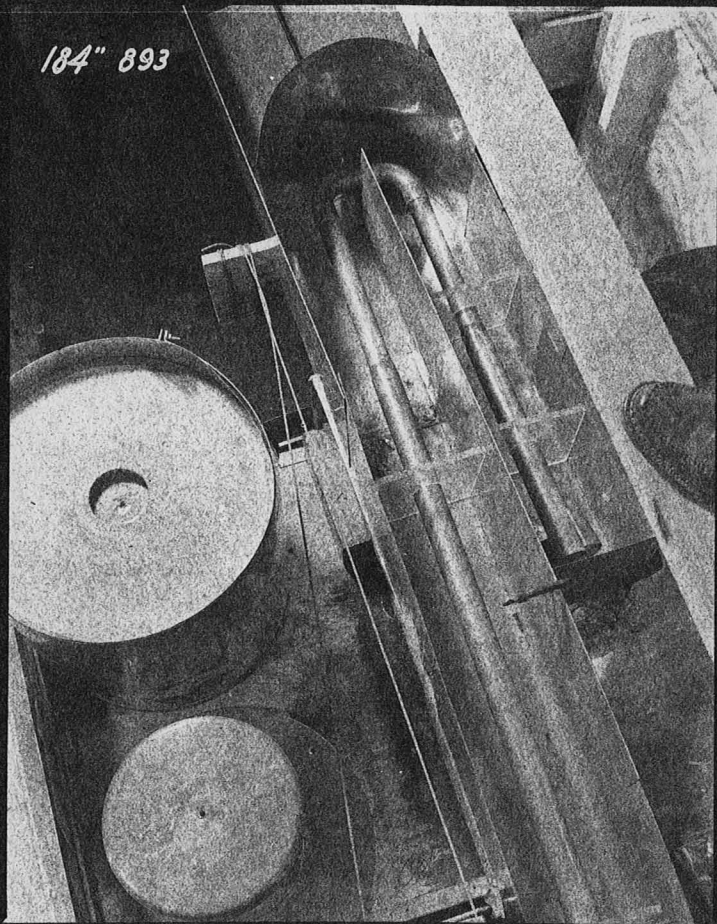

184" 893

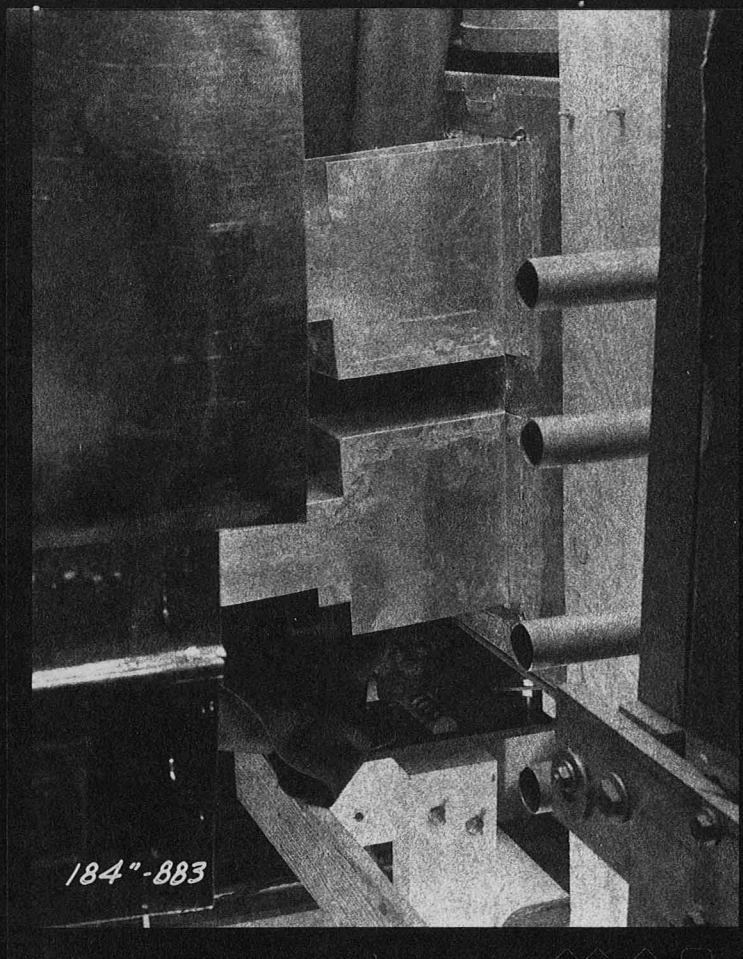

Filament loop housing at the entrance into the tank.

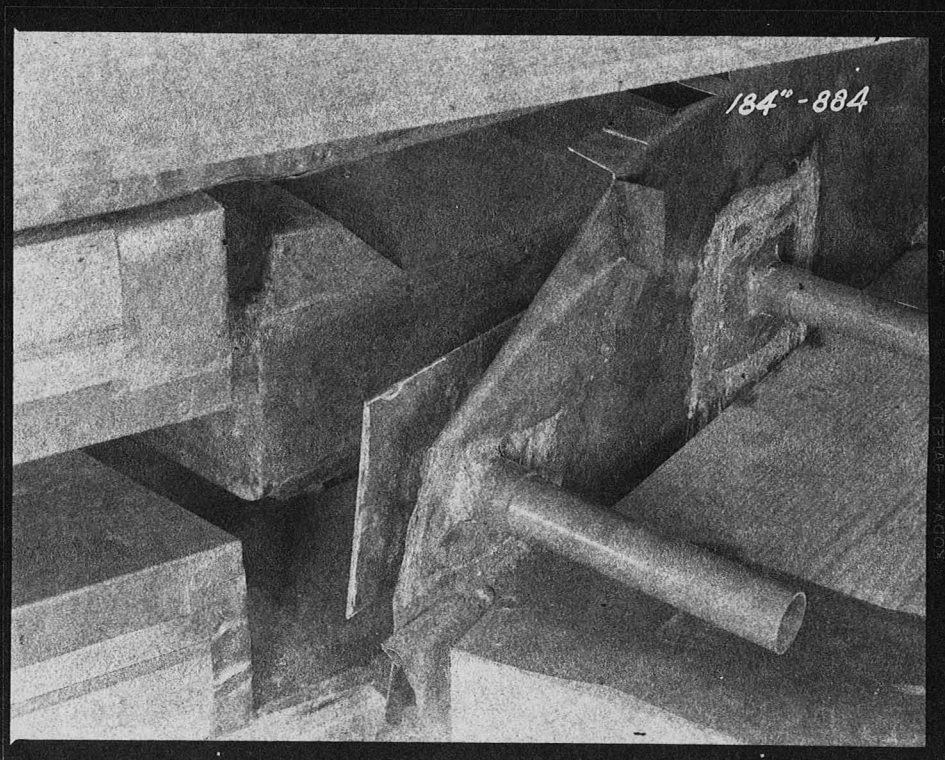

The capacitor at a corner of the dee for lowering the frequency.

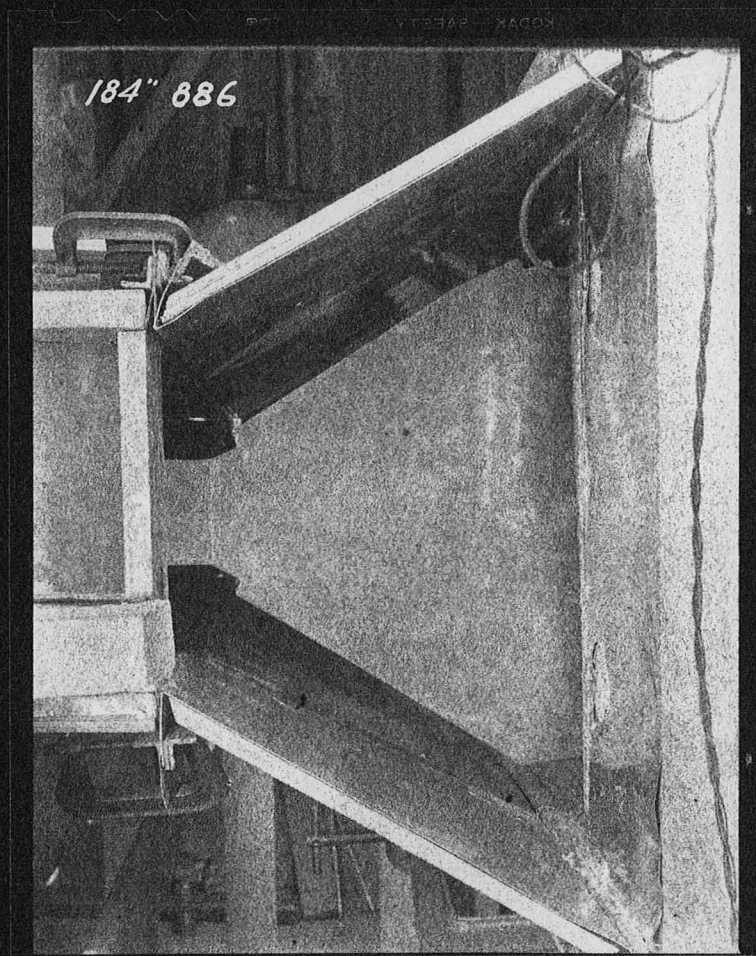

Dee throat.

DEE THROAT

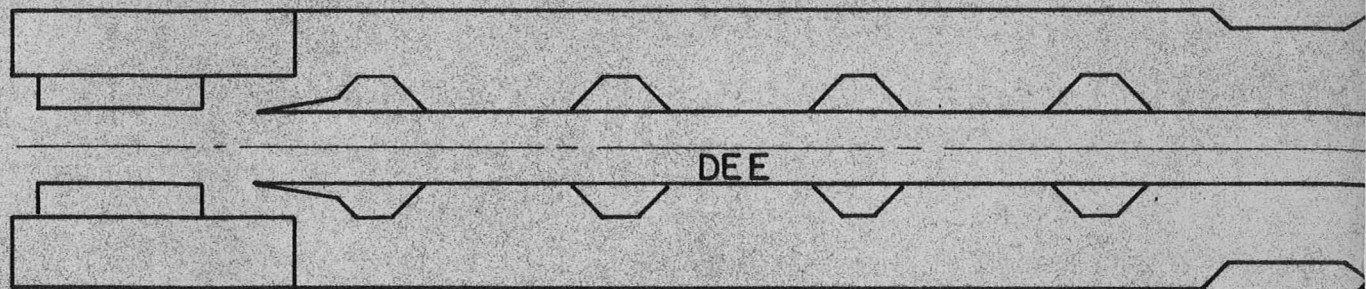

DUMMY DEE

MAGNET POLE SHIM

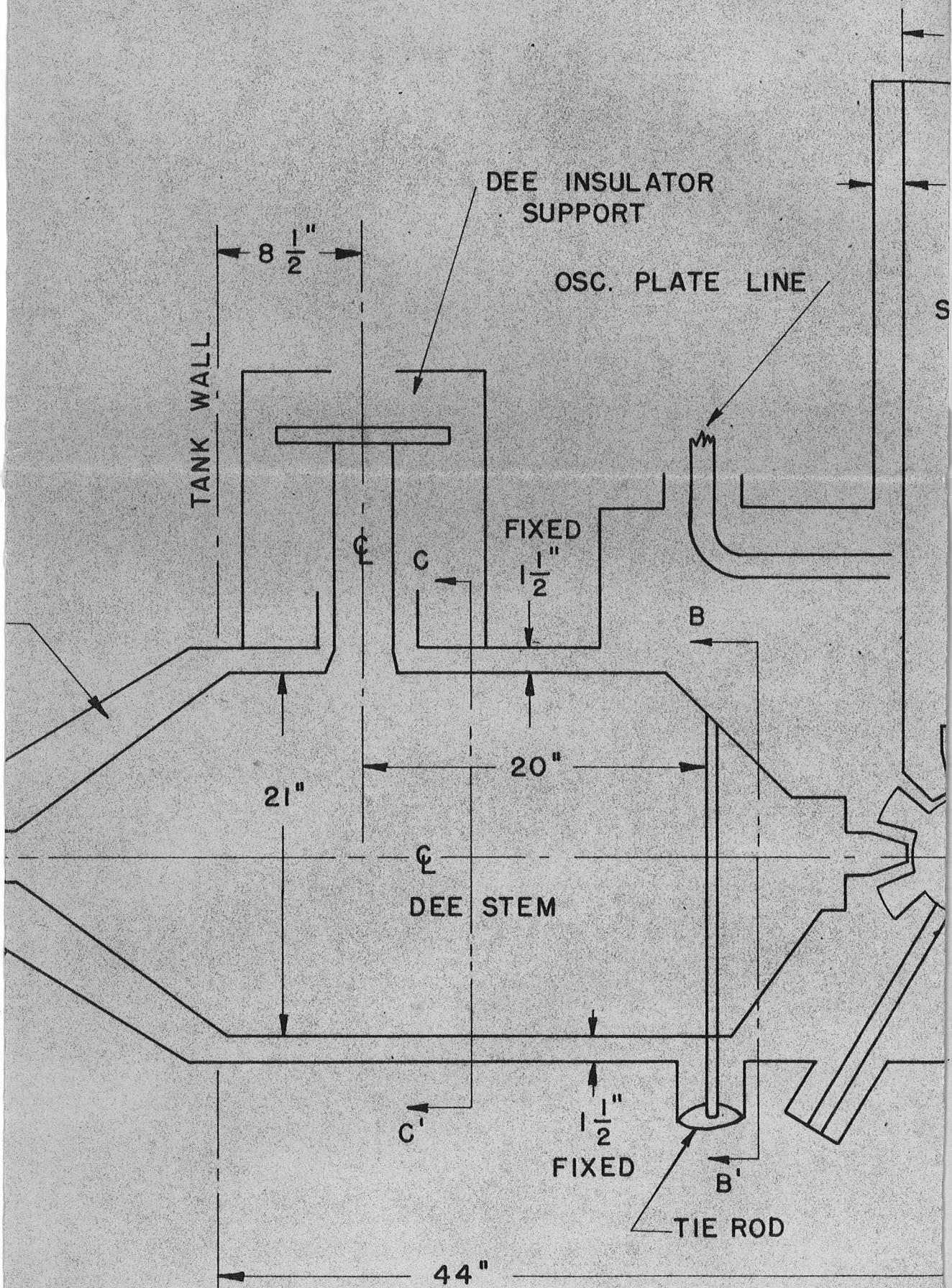

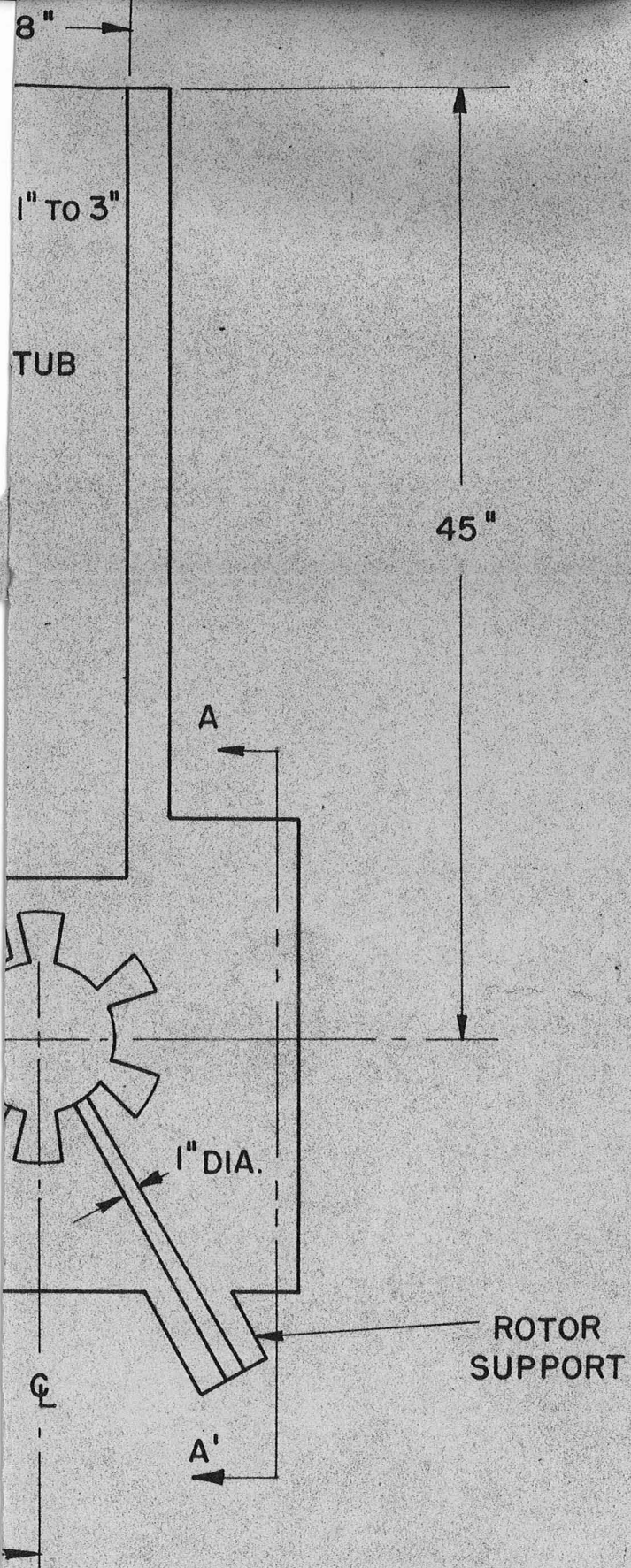

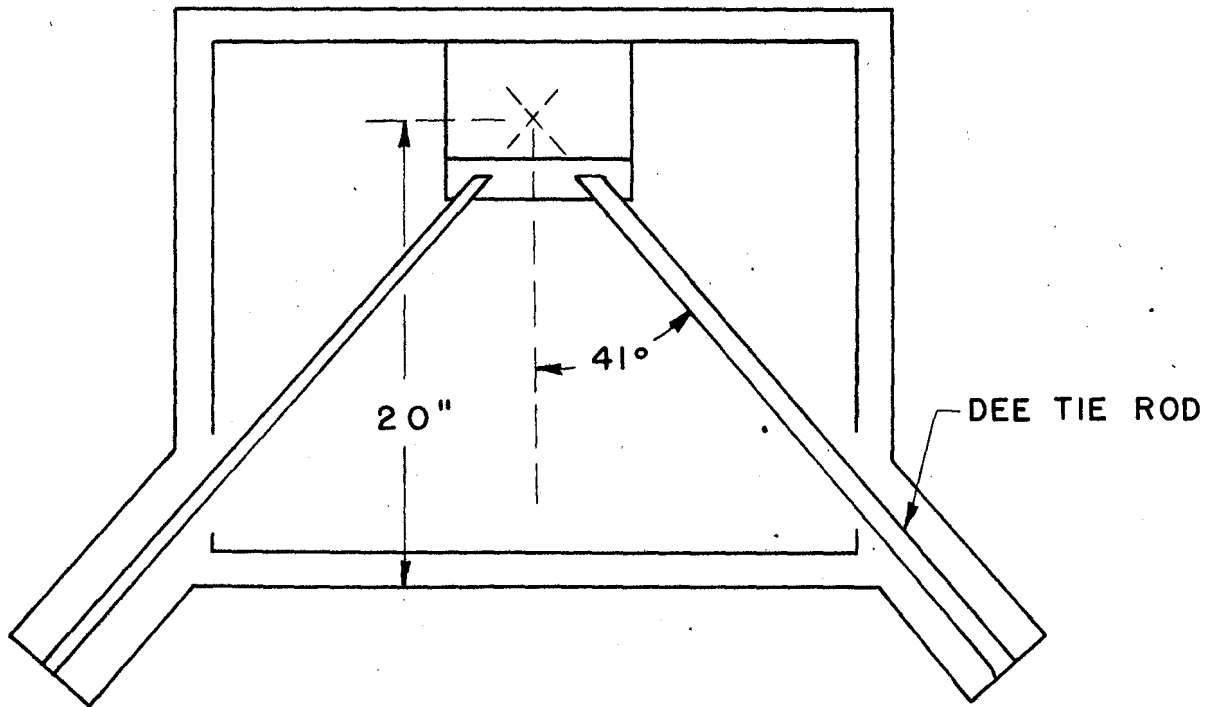
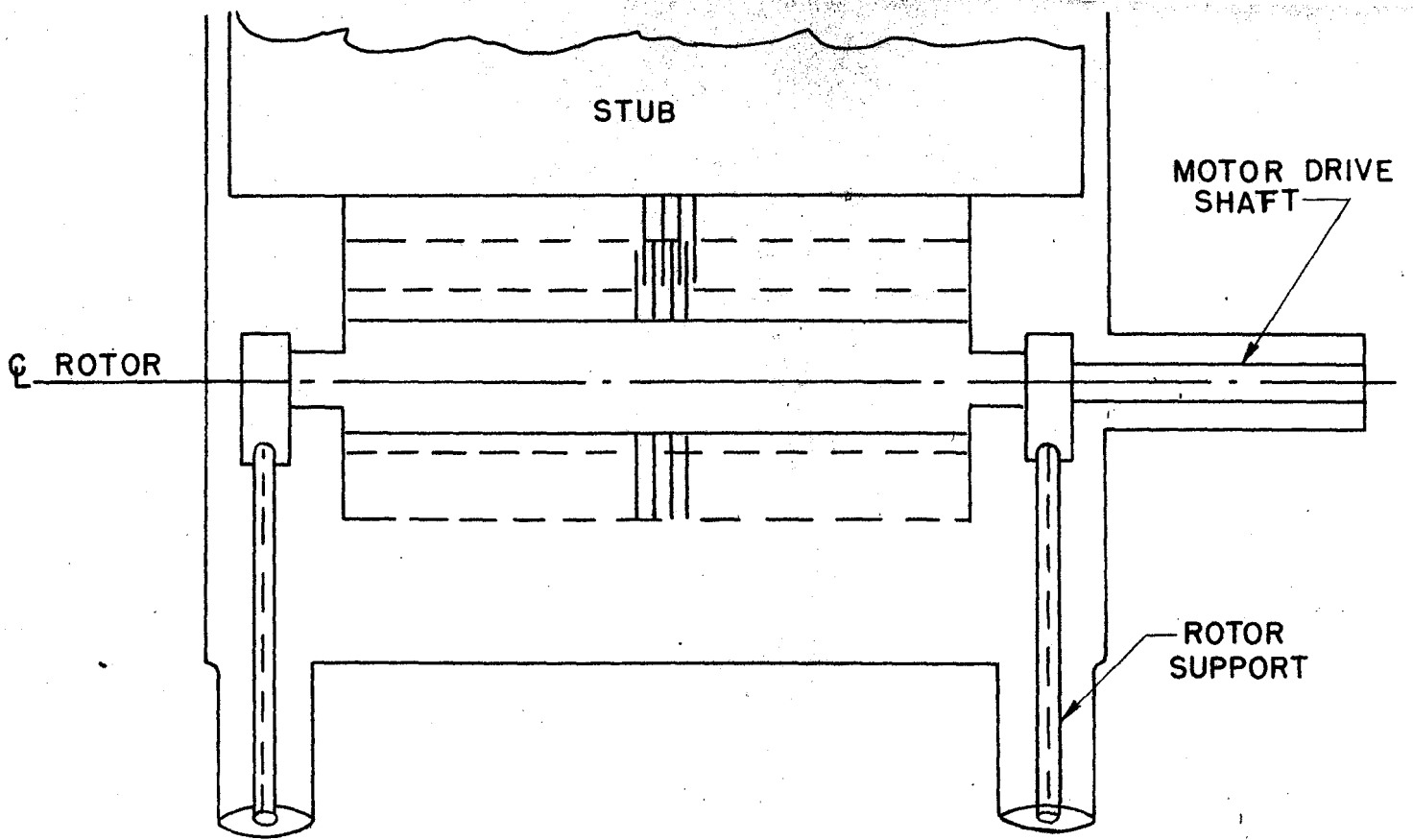

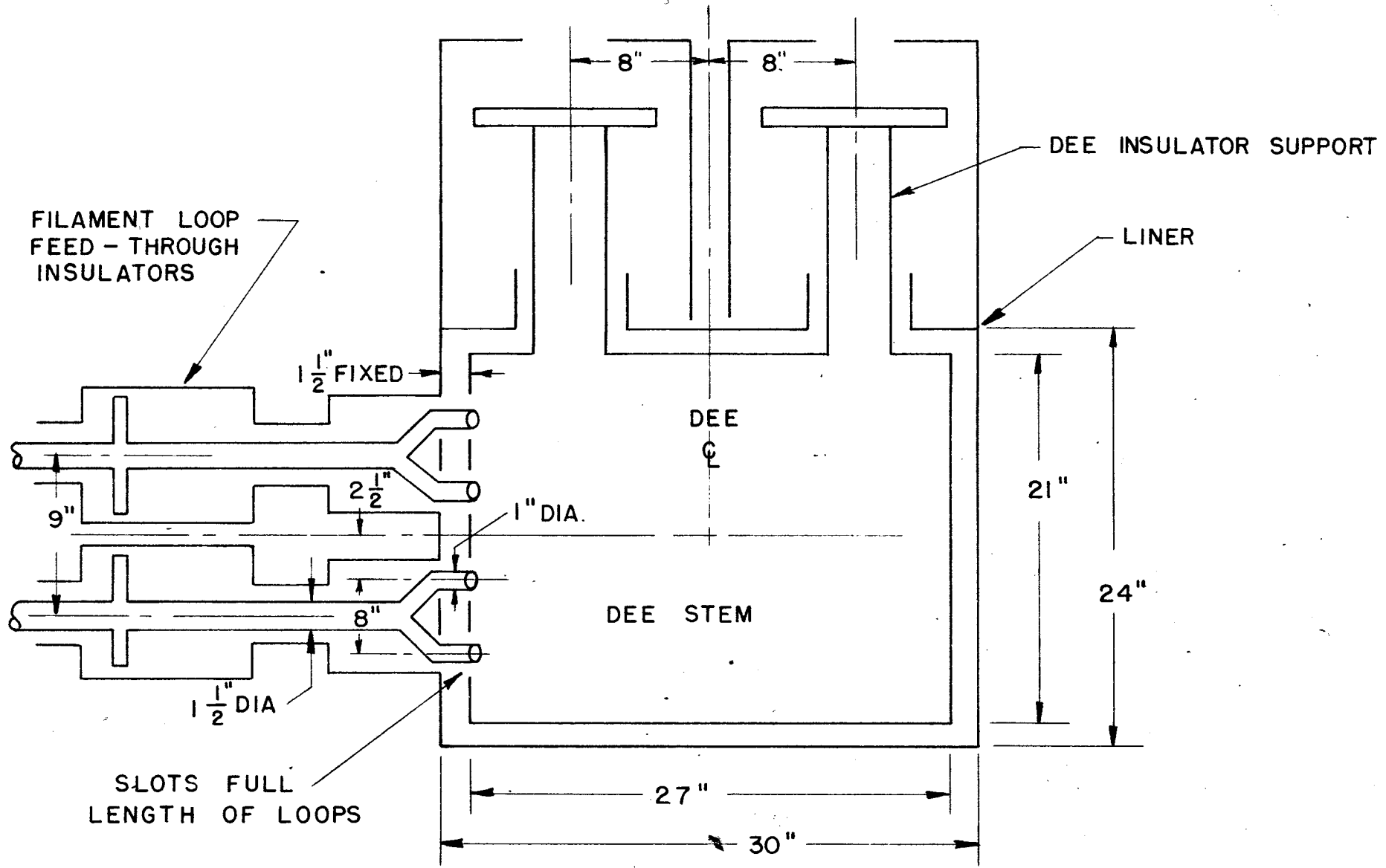

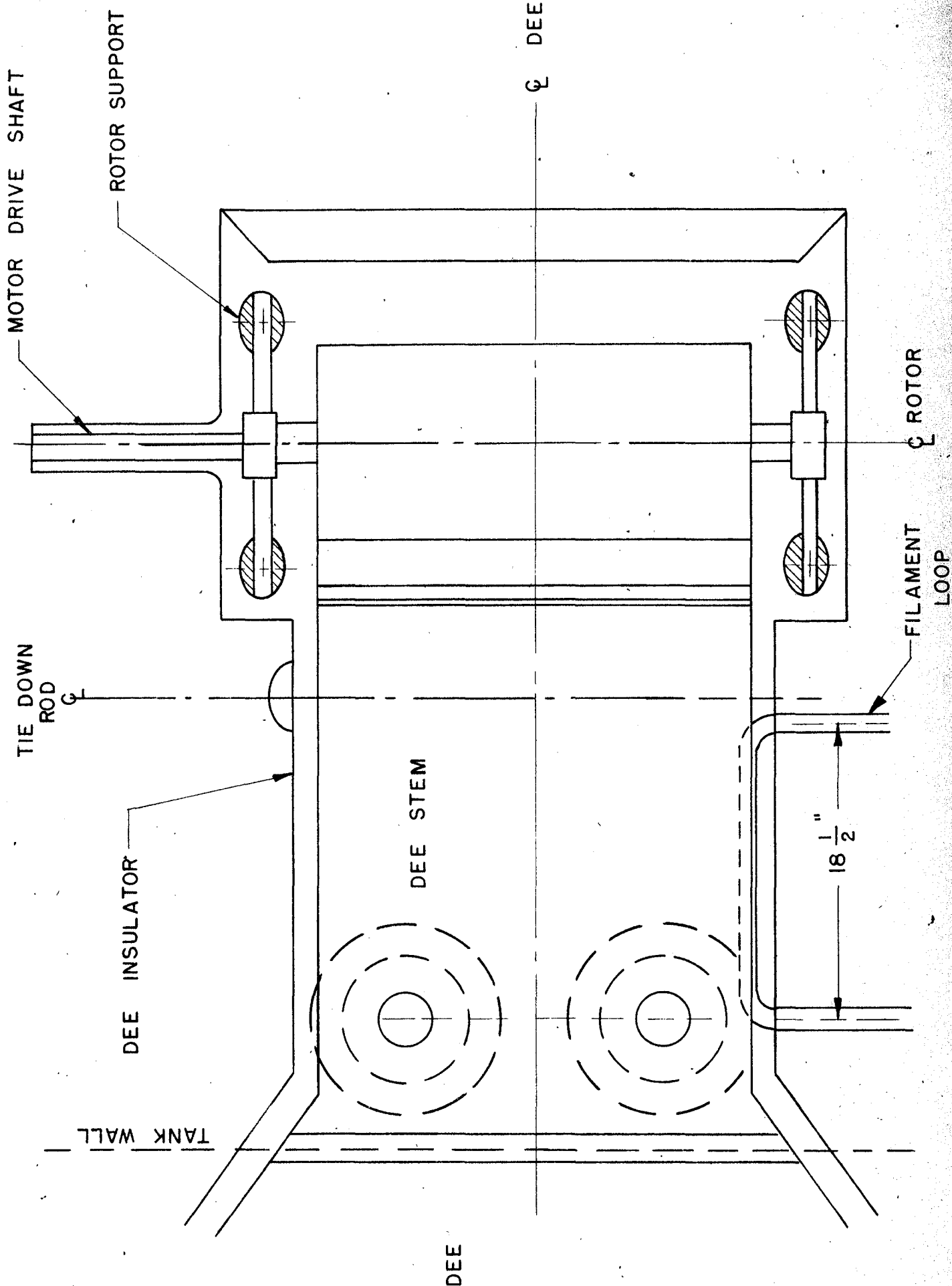

MOTOR DRIVE SHAFT

ROTOR SUPPORT

ϕ DEE

TIE DOWN ROD
 ϕ

DEE INSULATOR

DEE STEM

ϕ ROTOR

FILAMENT LOOP

$18 \frac{1}{2}$ "

TANK WALL

DEE

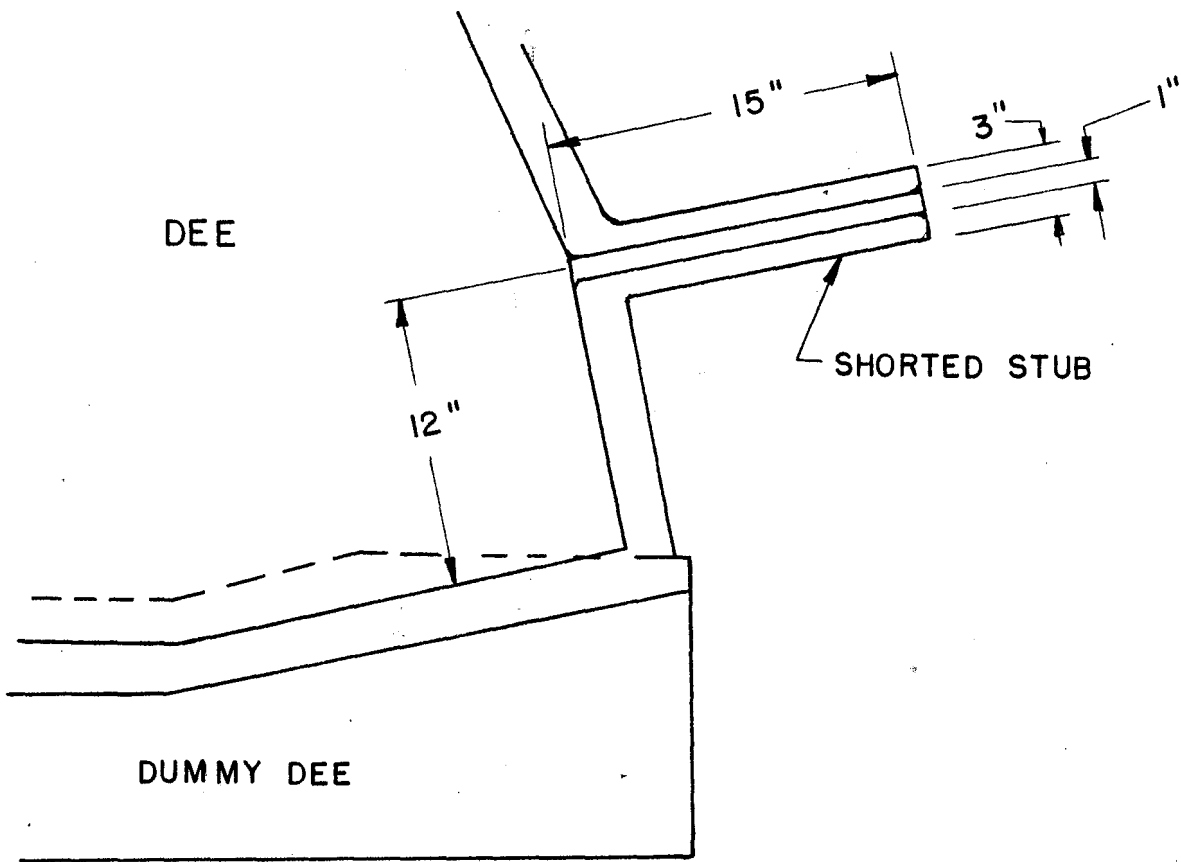
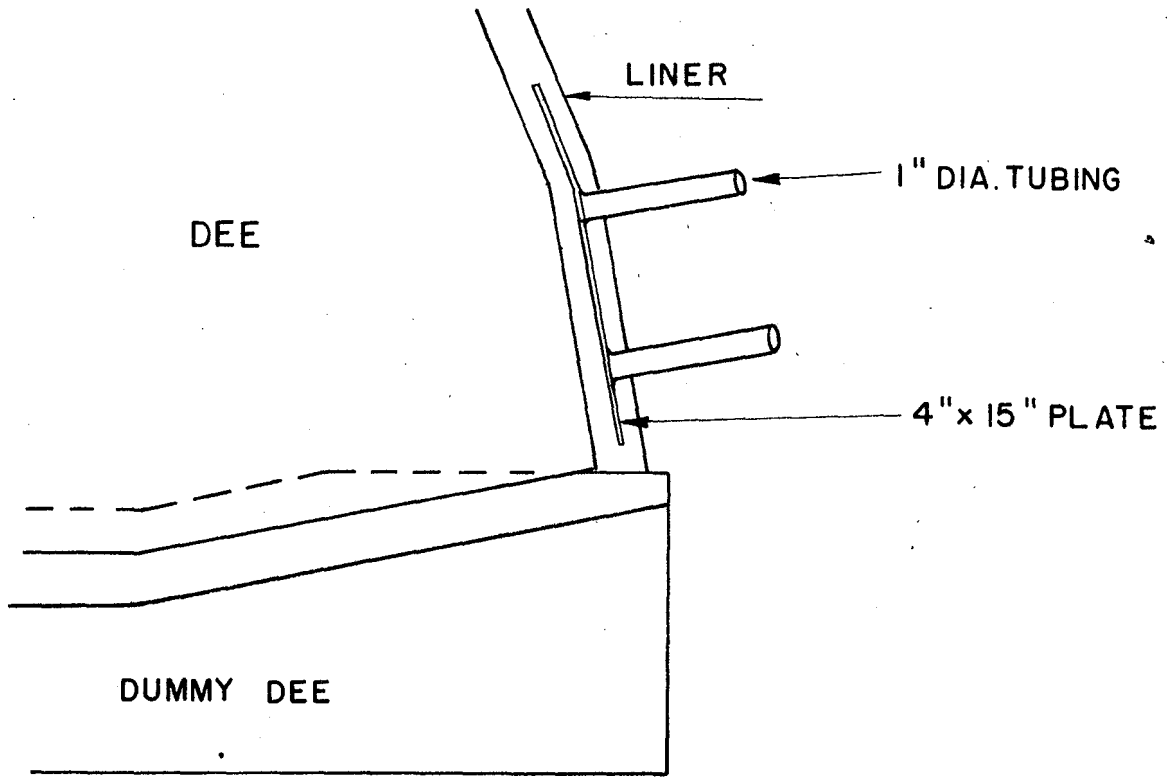

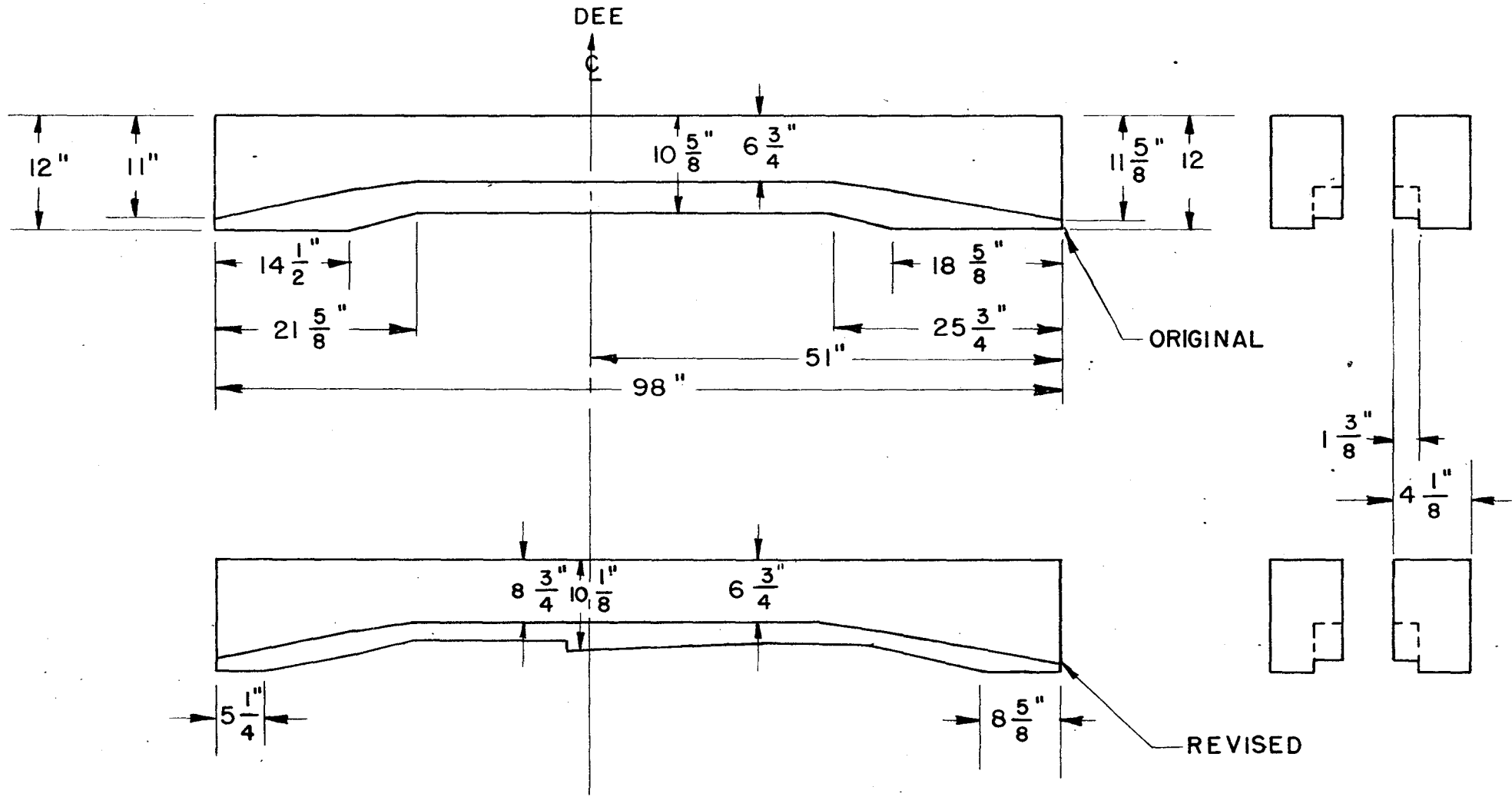

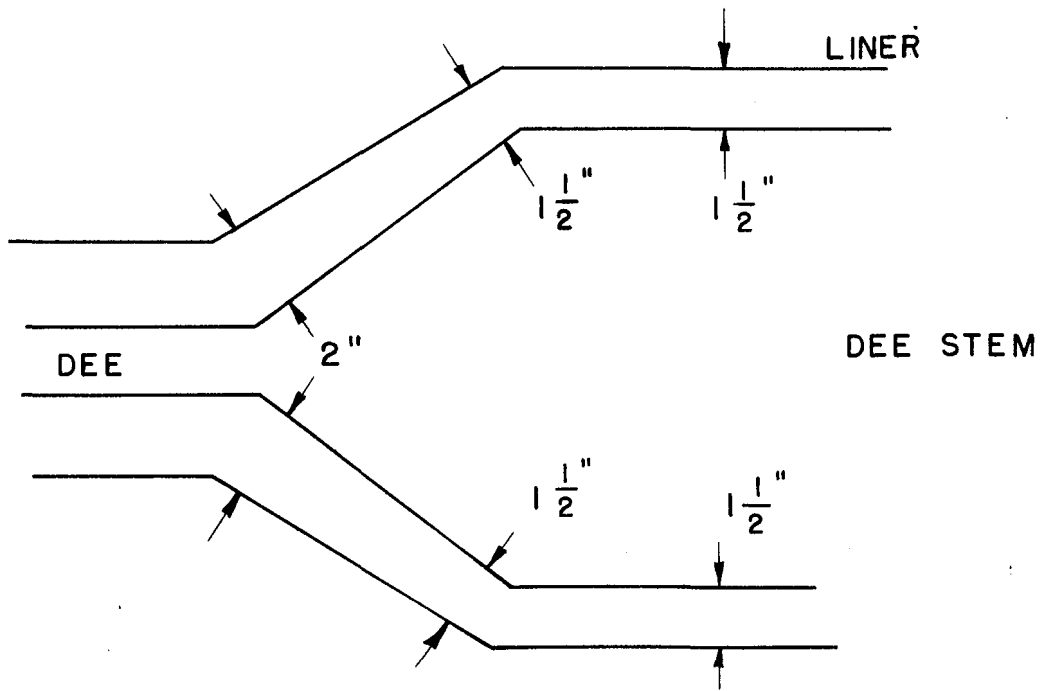
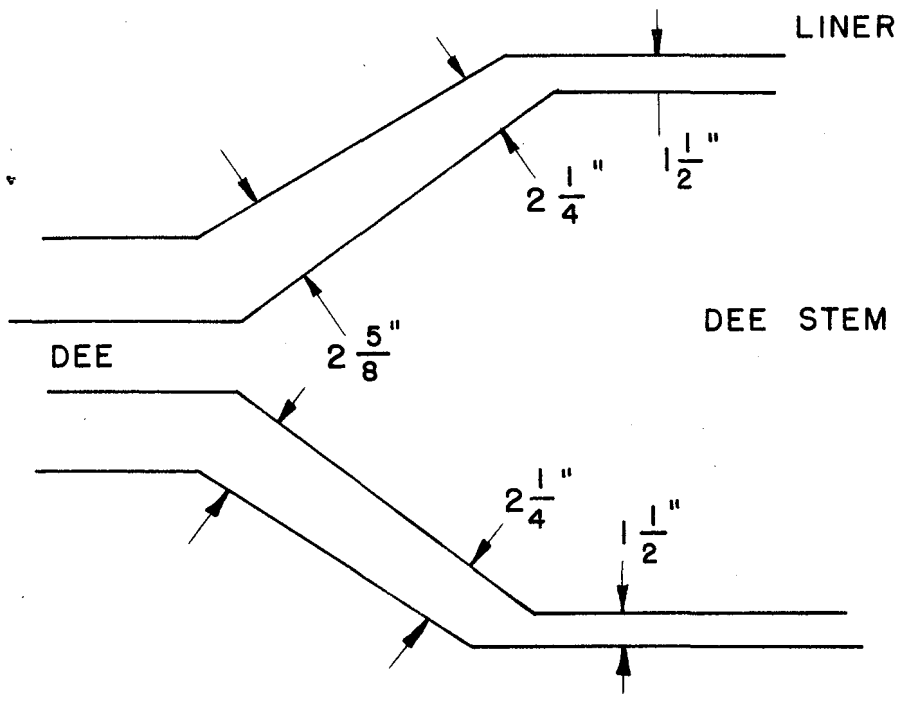

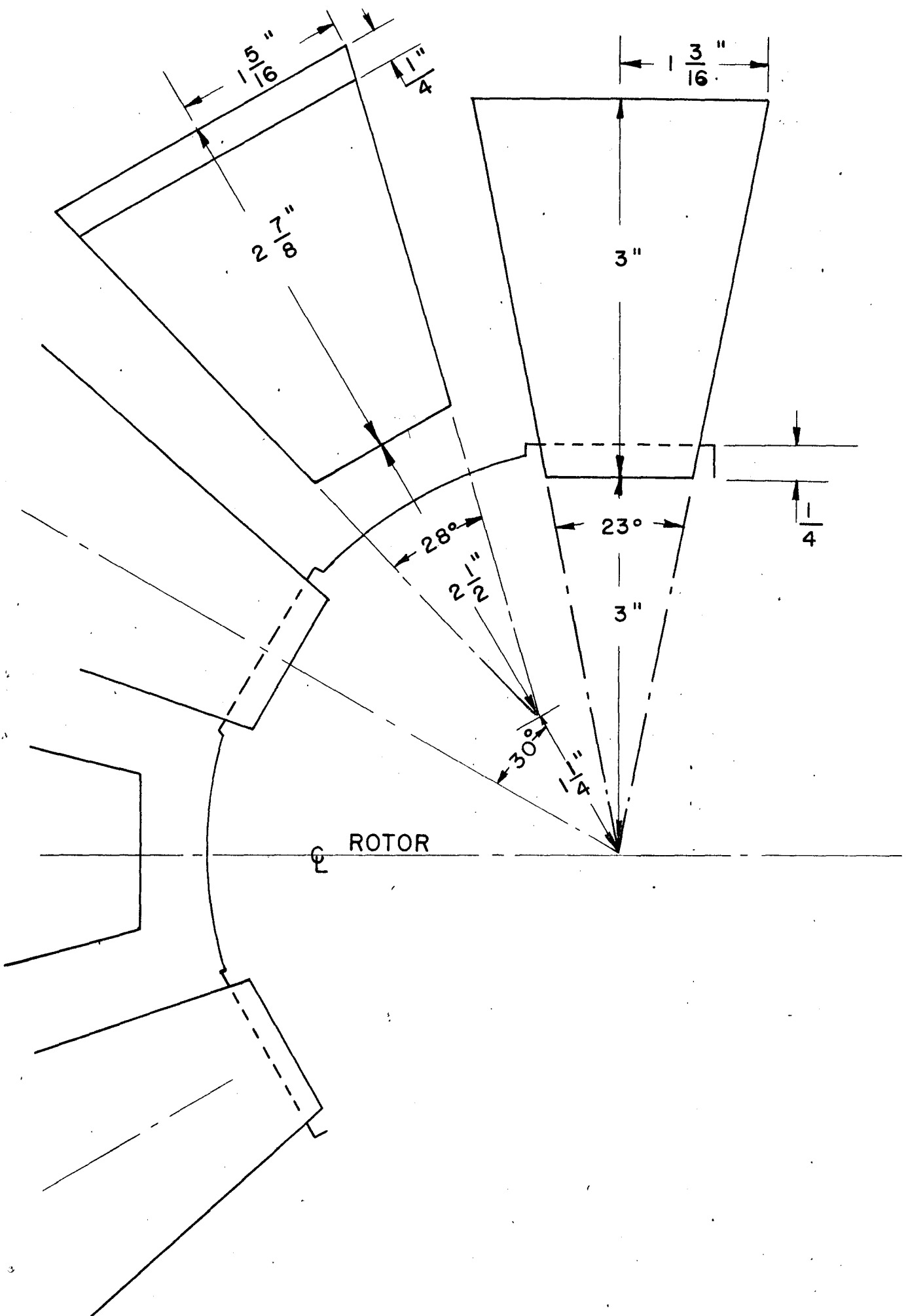

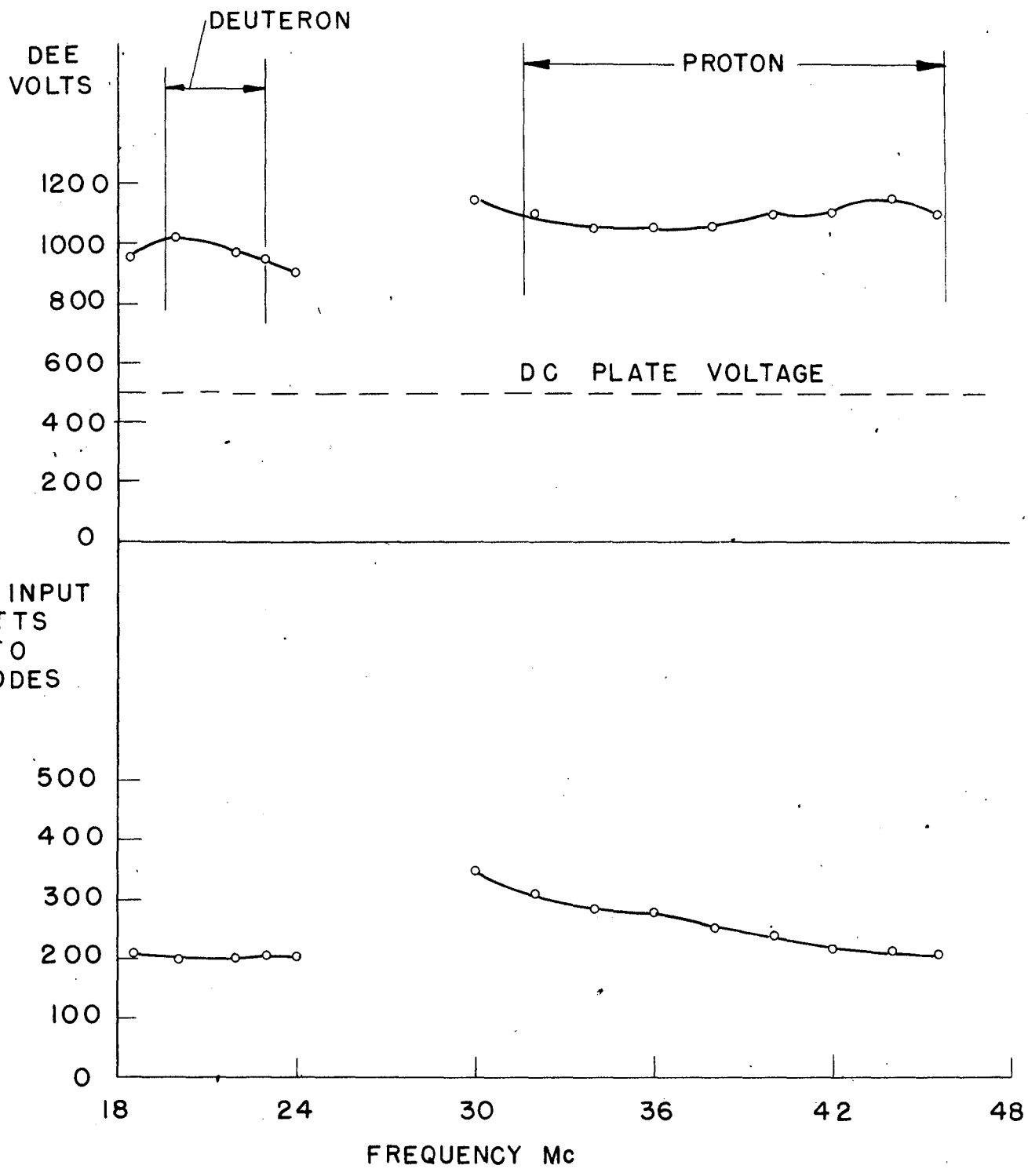

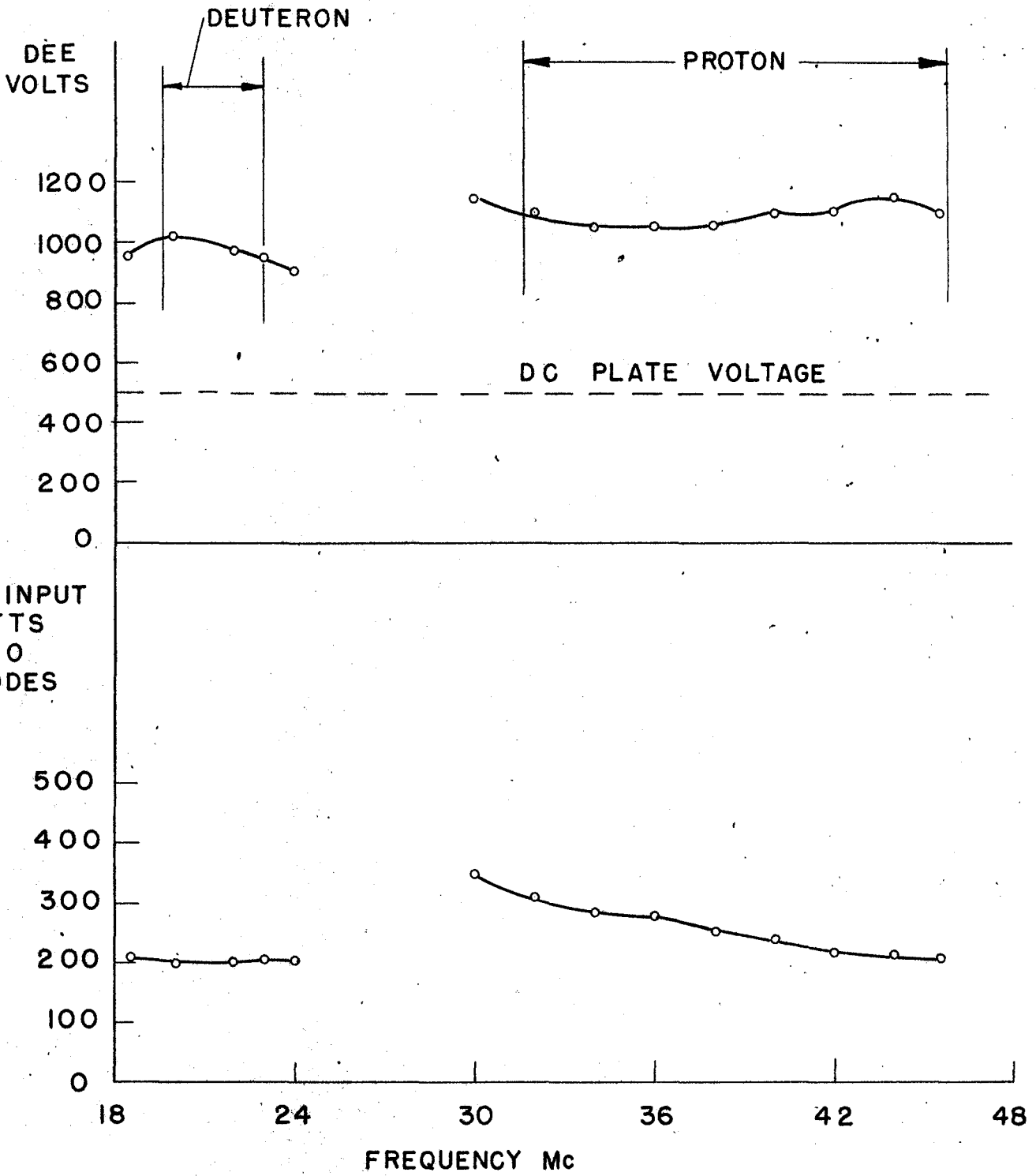

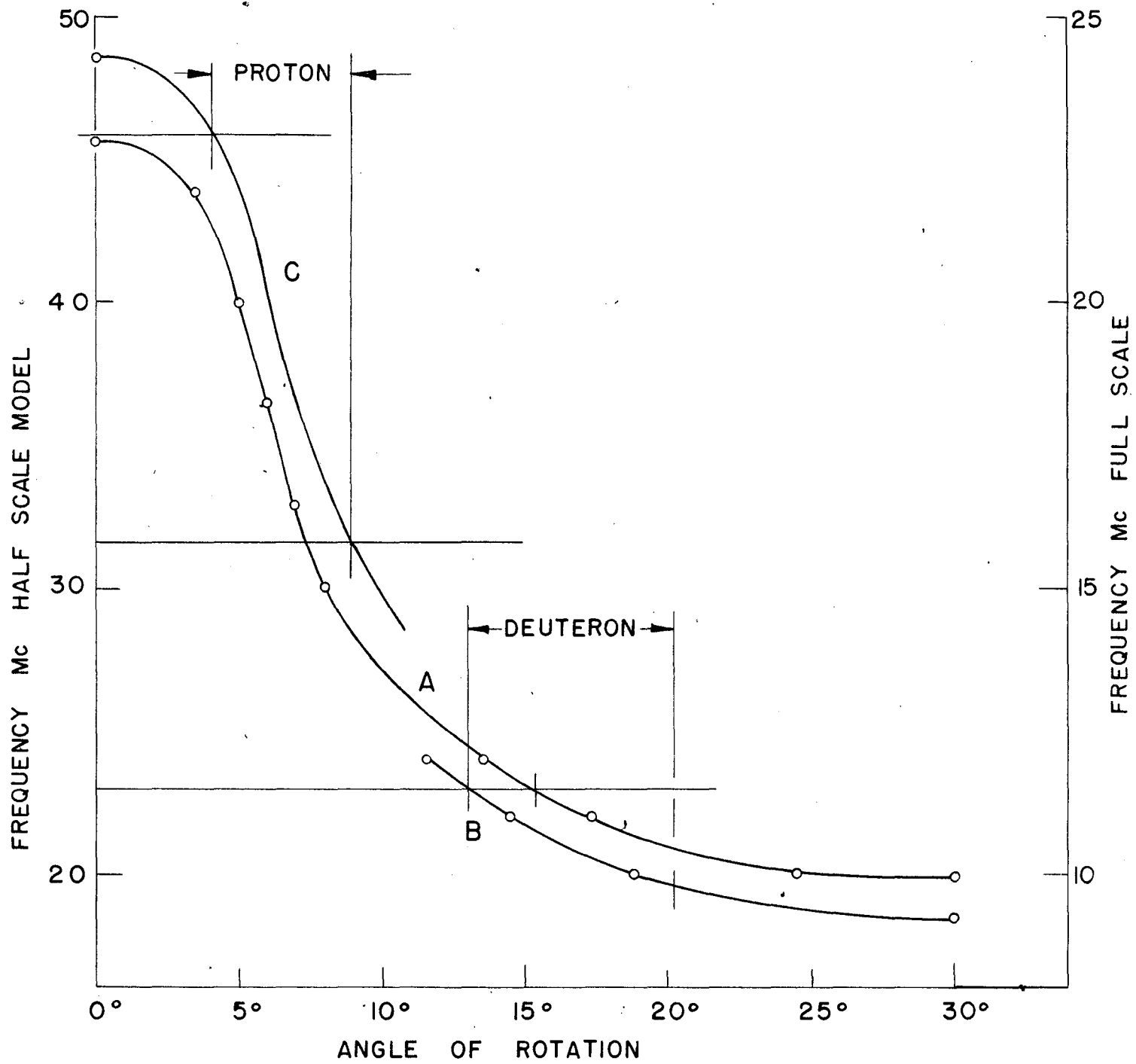

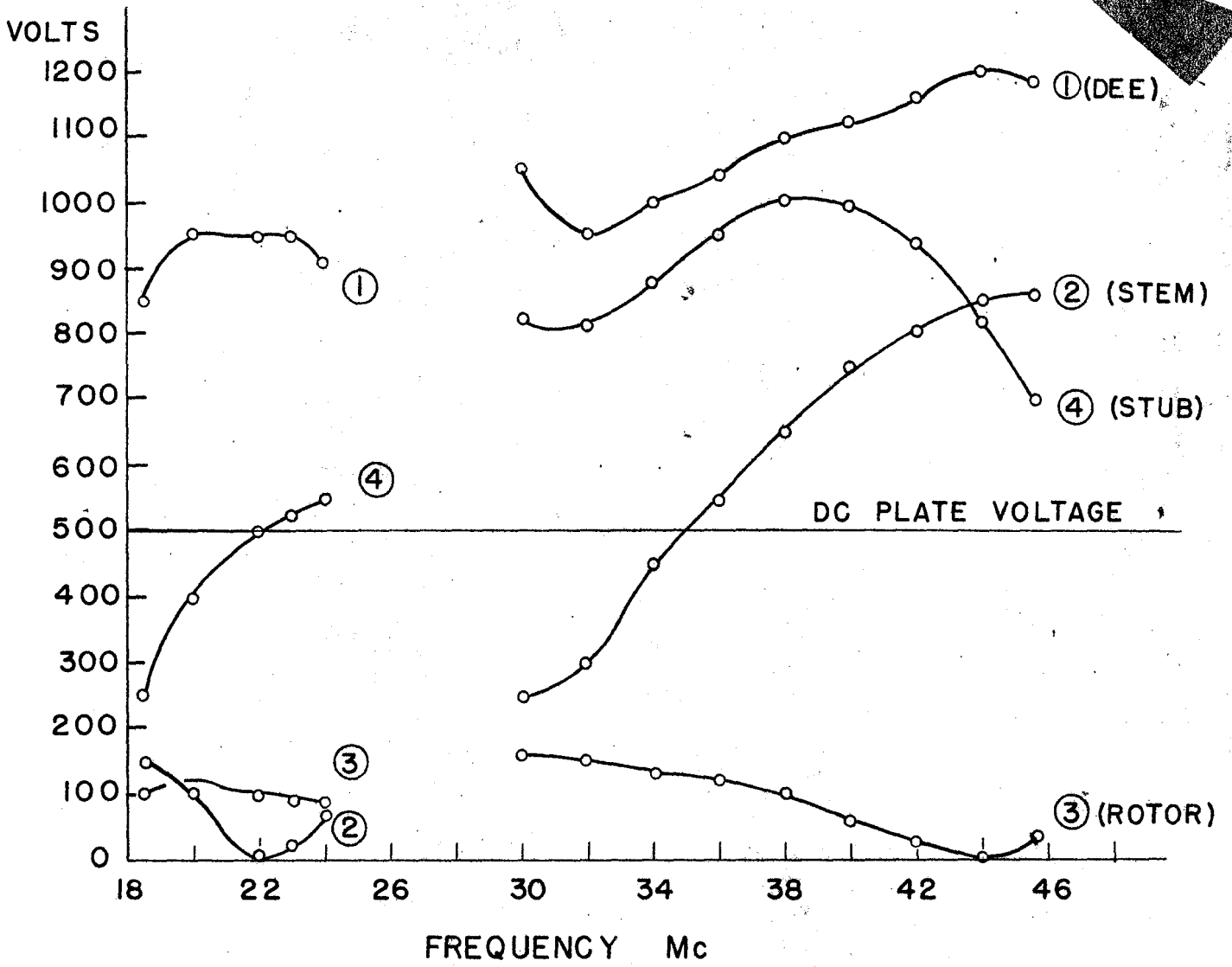

VOLTMETERS LOCATED AT POINTS INDICATED BELOW.

