

A 5kV/15W Dual-Transformer Hybrid Converter with Extreme 2000X Conversion Ratios for Soft Mobile Robots

Tianshi Xie^{*†}, Miquel Ricart Oltra[‡] and Hanh-Phuc Le^{*†}

^{*}Department of Electrical, Computer and Energy Engineering, University of Colorado, Boulder, Colorado

[†]Department of Electrical and Computer Engineering, University of California San Diego, La Jolla, California

[‡]Barcelona East School of Engineering, Polytechnic University of Catalonia, Barcelona, Spain

{tianshi-xie, hanhphuc}@ucsd.edu

Abstract—This paper describes the topology, fundamental operations, and key characteristics of a Dual-Transformer Hybrid converter that is capable of supporting extremely large conversion ratios for future soft mobile robots from an input voltage range of a 1-cell battery pack. The circuit topology employs a unique configuration of a fly-back transformer pair combined with a switched-capacitor network to support $\sim 2000X$ conversion ratios as well as output voltage regulation with a simple duty-cycle control. The hybrid combination also enables the two compact transformers to complete charge and discharge all flying capacitors for high overall efficiency. The Dual-Transformer Hybrid converter and its operation are verified in a prototype measured up to 5kV output, capable of delivering maximum loads up to 15W from a 1V-3V input, achieving peak efficiency of 75.1% at 1kV/1W and 74.6% at 3.3kV/9W output.

Keywords—Hybrid converter, fly-back, extremely large conversion ratio, soft-charging, switched-capacitor.

I. INTRODUCTION

Intelligent mechanical/electrical devices, i.e. robots, have been increasingly more integrated with human life, making revolutionary changes in our productivity at an unprecedented rate. The market size of robotic prosthetics alone was estimated at \$790.8 million in 2016 and is expected to grow to \$1.76 billion by 2025, i.e. CAGR of 9.2% [1]. Examples of robots can be found everywhere from factories, infrastructure smart machines, to prosthetic limbs and artificial muscles. They can be divided into two categories: 1) industrial robots that require extra strength and are often constructed with rigid and heavier components, and 2) soft robots that are more directly connected to human and nature requiring soft, versatile, lightweight, and compact materials to conform to their environment. In these two groups, soft robots have recently received a lot of attention from academic research and industry because of their promise for fundamentally new and transformative methods for humans to interact with machines; for example, drastically different lines of soft prostheses, medical devices, and autonomous robotic devices [2], [3], [4].

A key challenge in adopting these soft robots in practice lies in the electronics to support them. Particularly, many soft robots require modular, miniaturized power supply and management units that can support high voltage (up to ~ 10

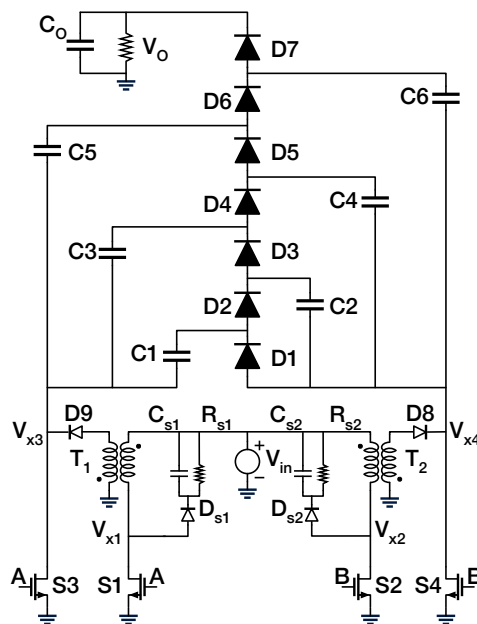

Fig. 1. The proposed Dual-Transformer Hybrid (DTH) converter schematic

kV) and relatively high power ($\sim 10s$ W) for their mechanical actuators [2], [4]. Available products that can support this voltage range suffer from a number of critical drawbacks: 1) they are either too large or too low power [5], [6], [7], [8] to be integrated in soft robotic systems; 2) they are mainly constructed with bulky large-ratio transformers making them incapable of scaling to large output currents while keeping a compact size, i.e. output current limited to 0.5 mA [6]; 3) they have fixed conversion ratios and do not support output regulation, and 4) their efficiency is limited to 70% [6], causing the hosting robotics systems to require power tethering or larger and heavier battery and thus reduce the system mobility. The drawbacks limit the use of these available products strictly to small-scale demonstrations in labs but not scalable to large-scale mobile systems in practical use.

In order to overcome these drawbacks, this paper presents a modular, efficient Dual-Transformer Hybrid (DTH) converter,

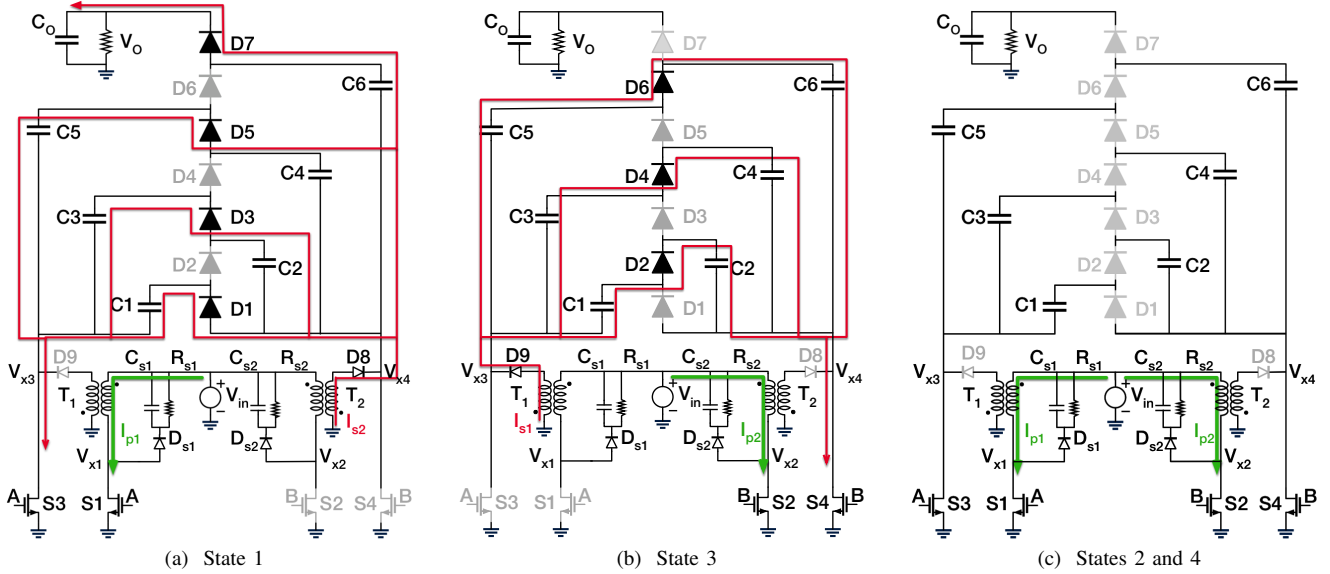

Fig. 2. Operation of the proposed DTH converter

as shown in Fig. 1, that exploits advantages of hybrid converter techniques suitable for large conversion ratios [9], [10] utilizing two relatively small flyback transformers with turns ratio $N \approx 100$ and a switched-capacitor output network. The switched-capacitor enables the converter to support extremely large conversion ratios of $\sim 2000X$ while using small transformers and still being able to provide output regulation with a simple pulse width modulation control. Details of the converter topology and operation is provided in Section II. Section III presents experimental results of a converter prototype that can support an extreme $\sim 2000X$ conversion ratio from 1V-3V input to 1000V-5000V output at a maximum current of 3 mA, and a maximum load of 15W. Section IV concludes the paper.

II. TOPOLOGY AND OPERATION OF THE DTH CONVERTER

The proposed Dual-Transformer Hybrid (DTH) converter is shown in Fig. 1. The converter has two identical fly-back transformers, T1 and T2, at the input stage followed by a switched-capacitor (SC) voltage multiplication stage. The two transformers are operated in two 180° -interleaved phases, A and B, in synchronization with the two sides of the SC stage by controlling four power switches S1-S4. The SC stage employs a Dickson star step-up structure with 6 flying capacitors and 7 diodes to provide a voltage gain of 7. To damp the excessive ringing at the drain nodes of the primary side switch S1 (S2) a snubber circuitry composed of small diode D_{s1} (D_{s2}), resistor R_{s1} (R_{s2}) and capacitor C_{s1} (C_{s2}) is added to each flyback transformer [11]. The converter operation can be described with two interleaved magnetizing phases, A and B, and four states as illustrated in Figs. 2 and 3. During the turn-on time DT_s of phase A (B), S1 (S2) is turned on to magnetize transformer T1 (T2). As the transformers have opposite coupling coils, diode D9 (D8) at the secondary side

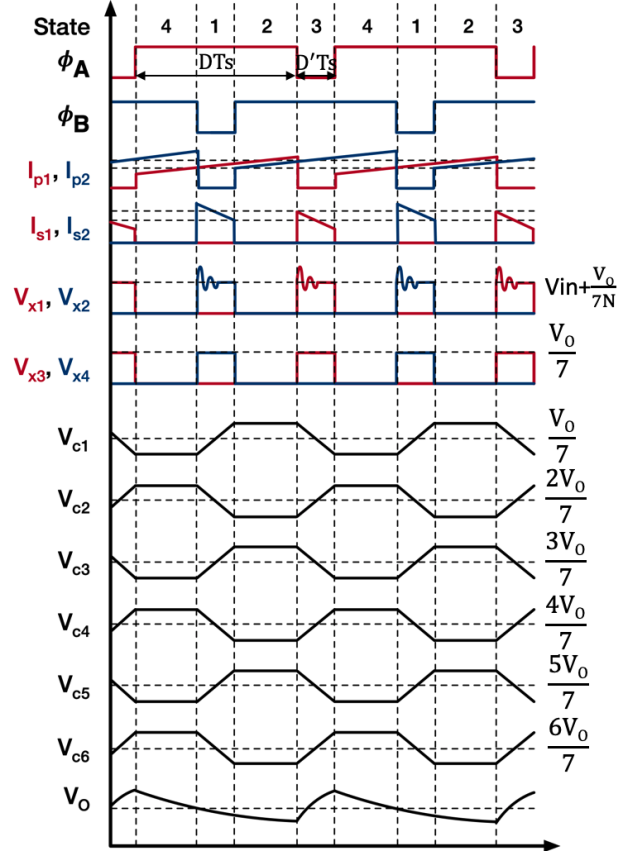
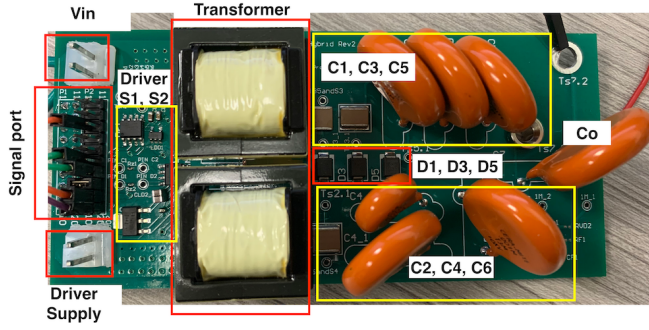
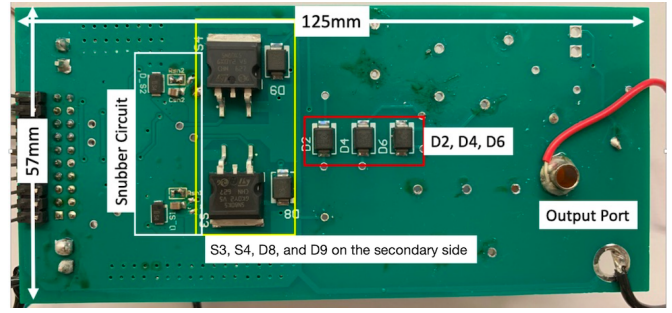

Fig. 3. The operation waveform of the proposed Dual-Transformer Hybrid (DTH) converter

of the respective fly-back transformer is reversed biased and not conductive, while switch S3 (S4) is on keeping V_{x3} (V_{x4}) to ground preparing capacitors C1, C3, and C5 (C2, C4, and C6) to be charged. In state 1 shown in Fig. 2a, while S1



(a) Front side



(b) Back side

Fig. 4. PCB prototype of the proposed DTH converter

TABLE I
MAJOR COMPONENTS

Part	Information
$S1, S2$	TSM240N03CX
$S3, S4$	IXTA05N100HV
$C1$	1nF 5kV Vishay
$C2$	3.3nF 5kV Vishay
$C3$	1.5nF 5kV Vishay
$C4$	1nF + 0.5nF, 10kV Vishay
$C5$	1nF 10kV Vishay
$C6$	1nF 10kV Vishay
$T1, T2$	Coilcraft FL2015-10L and custom EE cores, turns ratio $N \approx 100$
$D1 - D9$	GAP3SLT33-214

and $S3$ are on $T1$ is magnetizing. In this state, as phase B is low turning off $S2$ and $S4$, $T2$ is demagnetized to transfer its charge in terms of current through $D8$, $D1$, $D3$, $D5$, and $D7$ to soft-discharge $C2$ and $C4$ and soft-charge $C1$, $C3$, $C5$, and discharge $C6$ to the output V_o . Similarly in state 3 shown in Fig. 2b, while $S2$ and $S4$ are on $T2$ is magnetizing. As phase A is low turning off $S1$ and $S3$, $T1$ is demagnetized to transfer its charge in terms of current through $D9$, $D2$, $D4$, and $D6$ to soft-discharge $C1$, $C3$, and $C5$ to $C2$, $C4$, and $C6$. During states 2 and 4 in between state 1 and 3, all switches $S1$ - $S4$ are on, both $T1$ and $T2$ are magnetizing, all diodes $D1$ - $D9$ are off, idling all flying capacitors $C1$ - $C6$. As illustrated in Fig. 3, the total magnetizing period of transformer T_1 (T_2) is phase A (B) on time including both states 2 and 4 and state 1 (state 3) given by DT_s , where D is the duty ratio of the control signals A and B and T_s is the switching cycle. As a key advantage of this converter architecture, the efficient 7X voltage gain achieved from soft-charging the 6-capacitor Dickson SC stage reduces the voltage gain [12], and thus reduce the turns ratio required from the two transformers, leading to significant transformer size reduction for the same total conversion ratio. The converter conversion ratio M is determined as $M = \frac{7ND}{1-D}$, where N is the turns ratio of $T1$ and $T2$. Accordingly, the switching node V_{x3} , V_{x4} will swing between $\frac{NDV_{in}}{1-D}$, i.e. equivalent to $\frac{V_o}{7}$, and 0, and the steady-state voltage across the flying capacitors $C1 - C6$ are $\frac{V_o}{7}$,

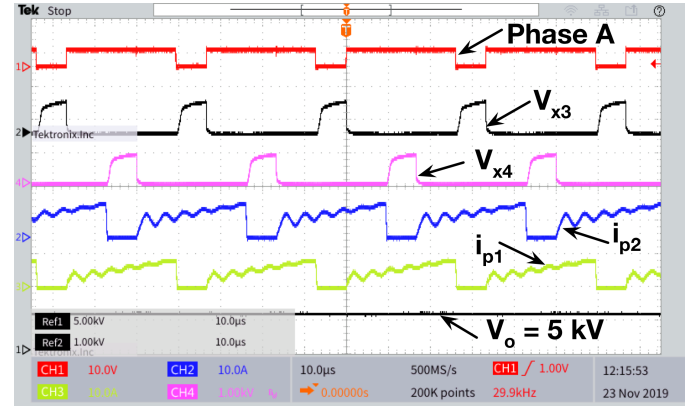

Fig. 5. Steady-state waveforms measured at 2.5V-to-5kV conversion, 3mA load, and 30kHz switching frequency

$\frac{2V_o}{7}$, $\frac{3V_o}{7}$, $\frac{4V_o}{7}$, $\frac{5V_o}{7}$, and $\frac{6V_o}{7}$, respectively. This output SC stage also allows diodes $D1$ - $D9$ and switches $S3$ - $S4$ at the high-voltage secondary side to block only a fraction of output voltage, i.e. $\frac{V_o}{7}$ for $S3$ - $S4$ and $D7$ - $D9$ and $\frac{2V_o}{7}$ for $D1$ - $D6$, enabling selection of small devices.

III. HARDWARE IMPLEMENTATION AND EXPERIMENTAL RESULTS

A prototype of the proposed Dual-Transformer Hybrid (DTH) converter was implemented on a printed circuit board (PCB) shown in Fig. 4 using the components listed in Table I. A challenge in this converter implementation is to choose components satisfying both extremely high voltage blocking and small size constraints. Particularly for the transformers, the trade-off is between a large turns ratio, from which the converter can achieve a higher conversion ratio, a convenient duty cycle for easy timing control, and the maximum output current capability, from which the converter can reach a higher output power. Considering this trade-off, custom transformers were designed and manufactured with that has 1 : 100 turns-ratio using EE cores.

Figure 5 shows a capture of the key operational waveforms when the converter is operated at 2.5V-to-5kV conversion with load current of 3 mA, i.e. 15W output. The waveforms, in order, are phase A control signal, V_{x3} , V_{x4} , current i_{p2} of transformer T_2 primary coil and i_{p1} of T_1 . As shown in

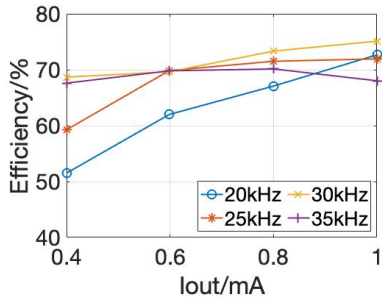

(a) 2V-to-1kV with Coilcraft transformers

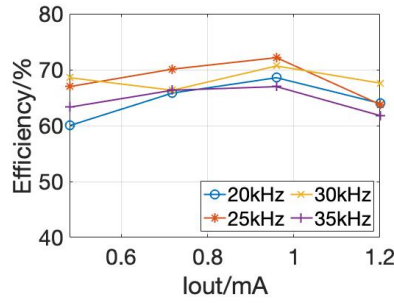

(b) 2V-to-1.2kV with Coilcraft transformers

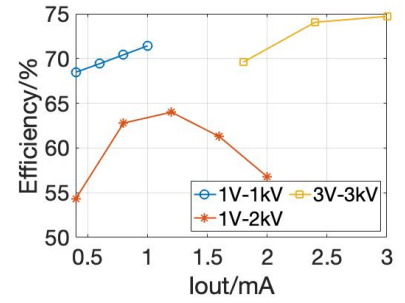

(c) Using custom EE-core transformers

Fig. 6. Measured efficiency of the DTH converter prototype

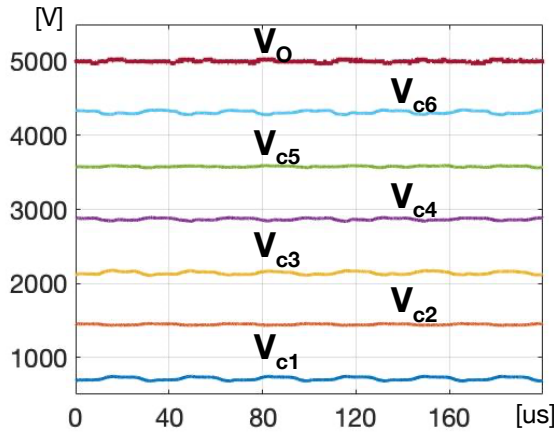

Fig. 7. Measured flying capacitor voltages and output voltage at 2.5V-5kV/3mA and $f_s=30\text{kHz}$

Fig. 5, switching nodes V_{x3} and V_{x4} only need to swing a fraction of the output voltage, $\sim \frac{V_{in}}{7}$. Figure 7 illustrates the voltages of flying capacitors C1-C6 in the demonstrating the correct operation of the SC network in this 2.5V-to-5kV, i.e. 2000X, conversion. This experiment validates the converter's functionality in both the flyback operation of the transformers and the advantage of using the output SC network to reduce the conversion needed at the transformers.

The converter efficiency is measured using a reconfigurable load, implemented by a bank of high-voltage precise $5M\Omega$ resistors, and two types of transformers, Coilcraft FL2015-10L and custom-made. Different output voltages are generated by controlling duty cycle D of energizing phases A and B from a micro controller.

Figures 6a and Figure 6b show the measured efficiency using two FL2015-10L Coilcraft transformers with different switching frequencies, while a pair of custom EE-core transformers are used to capture efficiency of the converter at 30kHz in Fig. 6c. Although Coilcraft transformers are relatively compact, their power is limited to 6W maximum and thus limiting achievable output voltages and output powers. Custom transformers were therefore employed to achieve conversion ratios up to 2000X, a maximum output voltage

up to 5 kV, and a peak output power up to 15 W. A peak efficiency of 75.1% is achieved at a 2V-to-1kV/1W conversion using Coilcraft transformers and 74.6% efficiency is achieved at 3V-to-3.3kV/9W conversion using the custom transformers with the switching frequency at $f_s = 30\text{kHz}$.

IV. CONCLUSIONS

In this paper, a new Dual-Transformer Hybrid converter is presented with the topology, operation, and experiment results. Thanks to the efficient synchronous operation between two compact flyback transformers and a SC output network, the proposed converter overcomes challenges and promises a very competitive converter for soft mobile robots that can support extremely large conversion ratio of 2000X and beyond, size constraint, high efficiency, and simple regulation control. A converter prototype board was implemented, achieving 75.1% peak efficiency for 2V-to-1kV/1W conversion, 74.6% for 3V-to-3.3kV/9W, and a peak power of 15W for a 2.5V-to-5kV/3mA conversion.

ACKNOWLEDGMENT

This work was supported in part by components and equipment purchased through a DURIP award from the the Office of Naval Research (ONR) and a seed funding from the Autonomous Systems Interdisciplinary Research Theme (ASIRT) at the University of Colorado Boulder. The authors would also like to thank Ratul Das, Christoph M. Keplinger, Shane K. Mitchell, Nikolaus Correll, Khoi D. Ly, Michael T. Tolley, and Shengqiang Cai for their technical feedback, support and many interesting and fruitful discussions.

REFERENCES

- [1] "Robotic Prosthetics Market Worth \$1.76 Billion By 2025 | CAGR: 9.2%," <https://www.grandviewresearch.com/press-release/global-robotic-prosthetics-market>.
- [2] D. Rus and M. T. Tolley, "Design, fabrication and control of origami robots," *Nature Reviews Materials*, vol. 3, no. 6, pp. 101–112, Jun. 2018.
- [3] A. Miriyev, K. Stack, and H. Lipson, "Soft material for soft actuators," *Nature Communications*, vol. 8, no. 1, p. 596, Sep. 2017.
- [4] E. Acome, S. K. Mitchell, T. G. Morrissey, M. B. Emmett, C. Benjamin, M. King, M. Radakovitz, and C. Keplinger, "Hydraulically amplified self-healing electrostatic actuators with muscle-like performance," *Science*, vol. 359, no. 6371, pp. 61–65, Jan. 2018.
- [5] P. Electronics, "SERIES AVP and AVN PLUG-IN DC-DC CONVERTERS | Pico," <https://www.picoelectronics.com/node/68748>.

- [6] —, “SERIES: VV,VV-P,VV-N | Pico,” <https://www.picoelectronics.com/node/13288>.
- [7] EMCO, “ISOLATED, PROPORTIONAL DC TO HV DC CONVERTERS 100V to 10,000V @ 0.5 Watts.”
- [8] —, “Extremely Low Profile: 0.128 inches and volume of < 0.100 cubic inches*5,” p. 10.
- [9] Z. Ye, Y. Lei, and R. C. N. Pilawa-Podgurski, “A 48-to-12 V Cascaded Resonant Switched-Capacitor Converter for Data Centers with 99% Peak Efficiency and 2500 W/in³ Power Density,” in *2019 IEEE Applied Power Electronics Conference and Exposition (APEC)*, Mar. 2019, pp. 13–18.
- [10] G.-S. Seo, R. Das, and H.-P. Le, “A 95%-Efficient 48V-to-1V/10A VRM Hybrid Converter Using Interleaved Dual Inductors,” in *2018 IEEE Energy Conversion Congress and Exposition (ECCE)*, Sep. 2018.
- [11] W. McMurray, “Optimum Snubbers for Power Semiconductors,” *IEEE Transactions on Industry Applications*, vol. IA-8, no. 5, pp. 593–600, Sep. 1972.
- [12] R. Das, G.-S. Seo, and H.-P. Le, “A 120V-to-1.8V 91.5%-Efficient 18-W Dual-Inductor Hybrid Converter with Natural Soft-charging Operations for Direct Extreme Conversion Ratios,” in *2018 IEEE Energy Conversion Congress and Exposition (ECCE)*, Sep. 2018.