

UC San Diego

UC San Diego Electronic Theses and Dissertations

Title

Regulation of intestinal chloride secretion by direct and indirect activation of the epidermal growth factor receptor

Permalink

<https://escholarship.org/uc/item/2wq4k7qc>

Author

Chappell, Alfred E.

Publication Date

2009

Peer reviewed|Thesis/dissertation

UNIVERSITY OF CALIFORNIA, SAN DIEGO

Regulation of intestinal chloride secretion by direct and indirect activation of the
epidermal growth factor receptor

A dissertation submitted in partial satisfaction of the
requirements for the degree Doctor of Philosophy

in

Biomedical Sciences

by

Alfred E. Chappell Jr.

Committee in Charge:

Professor Kim E. Barrett, Chair
Professor Joan Heller-Brown
Professor Christian Lytle
Professor Alexandra Newton
Professor Jason Yuan

2009

Copyright

Alfred E. Chappell Jr., 2009

All rights reserved

The Dissertation of Alfred E. Chappell Jr. is approved, and it is acceptable in quality and form for publication on microfilm and electronically:

Chair

University of California, San Diego

2009

This work is dedicated to my loving wife, Charlotte.

Table of Contents

Signature Page.....	iii
Dedication	iv
Table of Contents	v
List of Abbreviations	vi
List of Figures	viii
Acknowledgements	x
Vita	xi
Abstract of the Dissertation	xii
Chapter One Introduction	1
Chapter Two Materials and Methods	32
Chapter Three Role of EGFr in Regulating NKCC1 Localization an Activity	39
Chapter Four The Regulation of NKCC1 Through Covalent Modification with Ubiquitin and Small Ubiquitin-like Modifier	57
Chapter Five Discussion	75
References	86

List of Abbreviations

AKAP	PKA-binding A-kinase anchoring protein
CaCC	calcium-activated chloride channel
CaMK	calmodulin-dependent kinase
cAMP	cyclic adenosine monophosphate
CCh	carbachol or carbamylcholine
CF	cystic fibrosis
CFTR	cystic fibrosis transmembrane regulator
cGMP	cyclic guanosine monophosphate
CLCA	calcium-activated chloride channel
DMEM	Dulbecco's Modified Eagle Medium
DTT	dithiothreitol
EGF	epidermal growth factor
EGFr	epidermal growth factor receptor
ENaC	epithelial sodium channel
ERK	extracellular signal-regulated kinase
fsk	forskolin
GPCR	G-protein coupled receptor
IBD	inflammatory bowel disease
IFN γ	interferon gamma
Ins(3,4,5,6)P ₄	myo-inositol(3,4,5,6) tetrakisphosphate
JAK	janus kinase
MAPK	mitogen activated protein kinase
MLCK	myosin light chain kinase
NEM	N-ethylmaleimide
NHERF1	sodium/ hydrogen exchanger regulatory factor
NKCC1	sodium, potassium, 2- chloride, cotransporter 1
OSR1	oxidative stress-responsive-1
PAR	proteinase-activated receptor
PGE2	prostaglandin E2
PI3K	phosphoinositide-3-kinase
PKA	protein kinase A
PKC	protein kinase C
PKG	protein kinase G
PLC	phospholipase C
PMA	phorbol 12-myristate
PMSF	phenylmethanesulphonylfluoride

PP1	protein phosphatase 1
PP2A	protein phosphatase 2A
PTP1B	protein tyrosine phosphatase 1B
SPAK	Ste20p-related Proline Alanine-rich Kinase
SUMO	small ubiquitin-like modifier
TBS	Tris-buffered saline
TGF α	transforming growth factor alpha
VIP	vasoactive intestinal peptide
WNK	without-lysine kinase

List of Figures

Figure 1.1	Mechanisms of chloride secretion in intestinal epithelial cells	26
Figure 1.2	Regulation of ion channels and transporters	28
Figure 1.3	Divergent signaling through EGFr.	30
Figure 3.1	Carbachol stimulates internalization of NKCC1 while EGF does not. ...	49
Figure 3.2	Carbachol-stimulated internalization of NKCC1 requires transactivation of EGFr.	50
Figure 3.3	Cholinergic stimulation inhibits NKCC1 activity, however, EGF does not.	51
Figure 3.4	Cholinergic-stimulated inhibition of NKCC1 activity requires transactivation of EGFr.	52
Figure 3.5	Carbachol-stimulated internalization of NKCC1 is dependent on tyrosine phosphatase activity.	53
Figure 3.6	Cholinergic-stimulated internalization of NKCC1 may depend on activation of ERK MAPK.	54
Figure 3.7	Cholinergic-stimulated internalization of NKCC1 may depend on activation of p38 MAPK.	55
Figure 3.8	NKCC1 is not subject to proteasomal degradation in response to either EGF or carbachol, but carbachol-stimulated internalization of NKCC1 is proteasome-dependent.	56
Figure 4.1	Stimulation of intestinal epithelial cells with EGF may induce sumoylation of some proteins.	65
Figure 4.2	NKCC1 is rapidly and transiently sumoylated in response to EGF.	66
Figure 4.3	NKCC1 is covalently modified by SUMO.	67
Figure 4.4	Knockdown of EGFr abolishes effect of EGF on sumoylation of NKCC1.	68
Figure 4.5	NKCC1 is modified by SUMO-1 isoform.	69
Figure 4.6	Cholinergic stimulation fails to induce sumoylation of NKCC1.	70
Figure 4.7	Na ⁺ /K ⁺ ATPase is ubiquitinated in response to EGF stimulation.	71

Figure 4.8	NKCC1 is ubiquitinated in response to carbachol, but not EGF.	72
Figure 4.9	Cholinergic-stimulated ubiquitination of NKCC1 is independent of EGFr activation.	73
Figure 4.10	Cholinergic-stimulated ubiquitination of NKCC1 is inhibited by the proteasome inhibitor, MG132.	74
Figure 5.1	Divergent regulation of NKCC1 in response to differential activation of EGFr.	84

Acknowledgements

I would like to thank many members of the Barrett lab, past and present, for their advice and technical support, as well as their wonderful friendships and sharing desserts: Stephen Keely, Lone Bertelsen, Jane Smitham, Silvia Resta-Lenert, Cheryl Stork, Gisela Paul, Michael Scharl, and Glenda Wheeler. A special thank you to Kim Barrett and Declan McCole for both their close mentorship and great friendship. You showed me how to see the bigger picture and taught me how to tell the story of my work. Thank you to my thesis committee, Professors Joan Heller-Brown, Christian Lytle, Alexandra Newton, and Jason Yuan, for their guidance. Thank you to my parents, Al and Mary Chappell for all their support and encouragement throughout my life. Finally, thank you to my wife, Charlotte Chappell, whose unending love, support, and patience saw me through and who always had confidence in me, even when I did not.

The contents of Chapters One, Two, Three, Four, and Five in part or in full, are being prepared for submission for publication. (Chappell AE and Barrett KE. "Divergent regulation of NKCC1 through differential activation of EGFr: implications for intestinal ion transport" *In Preparation*. Alfred Chappell was the primary researcher and author for these chapters. Professor Kim Barrett supervised and directed the research that forms the basis for these chapters.

Vita

1998	Bachelor of Arts, Point Loma Nazarene University
1998-2000	Scientist, Isis Pharmaceuticals, Carlsbad, California
2000-2002	Research Associate, Isis Pharmaceuticals, Carlsbad, California
2008-2009	NSF Socrates Fellow
2009	Adjunct Faculty, Point Loma Nazarene University, San Diego, California
2009	Doctor of Philosophy, University of California, San Diego

Publications

Chappell AE, Bunz M, Smoll E, Dong H, Lytle C, Barrett KE, McCole DF. 2008. "Hydrogen peroxide inhibits Ca²⁺-dependent chloride secretion across colonic epithelial cells via distinct kinase signaling pathways and ion transport proteins." *FASEB Journal*. 22(6): 2023-36.

Smith A, Chappell A, Barrett KE, Dong H. 2006. "5-Hydroxytryptamine (5-HT) Contributes Importantly to a Reflex Pathway by Which the Duodenal Mucosa Protects Itself from Gastric Acid Injury." *FASEB Journal*. 20(14): 2486-95.

Butler M, Hayes CS, Chappell A, Murray SF, Yaksh TL, Hua XY. 2005. "Spinal distribution and metabolism of 2'-O-(2-methoxyethyl)-modified oligonucleotides after intrathecal administration in rats." *Neuroscience*. 131(3):705-15.

Geary RS, Yu RZ, Watanabe T, Henry SP, Hardee GE, Chappell A, Matson J, Sasmor H, Cummins L, Levin AA. 2003. "Pharmacokinetics of a tumor necrosis factor- α phosphorothioate 2'-O-(2-methoxyethyl) modified antisense oligonucleotide: comparison across species." *Drug Metabolism and Disposition*. 31(11):1419-28.

Yu RZ, Baker B, Chappell A, Geary RS, Cheung E, Levin AA. 2002. "Development of an ultrasensitive noncompetitive hybridization-ligation enzyme-linked immunosorbent assay for the determination of phosphorothioate oligodeoxynucleotide in plasma." *Analytical Biochemistry*. 304(1):19-25.

Heasley VL, Buczala DM, Chappell AE, Hill DJ, Whisenand JM, Shellhammer DF. 2002. "Addition of bromine chloride and iodine monochloride to carbonyl-conjugated, acetylenic ketones: synthesis and mechanisms." *Journal of Organic Chemistry*. 67(7):2183-7.

Heasley VL, Shellhammer DF, Chappell AE, Cox JM, Hill DJ, McGovern SL, Eden CC, Kissel CL. 1998. "Reactions of Carbonyl-Conjugated Alkynes with N-Bromosuccinimide (NBS) and N-iodosuccinimide (NIS) in DMF/H₂O and Methanol/ Sulfuric Acid: Synthesis of Dihalo Diketones, Dihalo Ketoesters and Dihalo Acetals." *Journal of Organic Chemistry*. 63(13); 4433-4437.

Abstract of the Dissertation

Regulation of intestinal chloride secretion by direct and indirect activation of the epidermal growth factor receptor

by

Alfred E. Chappell Jr.

Doctor of Philosophy in Biomedical Science

University of California, San Diego, 2009

Professor Kim E. Barrett, Chair

Intestinal fluid transport is critical for mediating proper digestion, absorption of nutrients, and clearance of waste, toxins, and pathogens, all without excessive dehydration. Movement of water is largely passive and driven by osmotic gradients established by active transport of ions. Apposite fluidity of intestinal contents is achieved through tightly regulated coordination of a complex machinery of ion transporters involved in both absorptive and secretory processes. The intestinal epithelium must respond to an ever-changing luminal environment and fluid transport is regulated in response to a variety of endogenous stimuli including neuronal, hormonal, and immune mediators, as well as exogenous environmental factors such as bacterial agents, nutrients, and toxins.

The epidermal growth factor receptor (EGFr) is an important regulator of intestinal chloride secretion and can be differentially activated in response to a variety of stimuli to elicit divergent effects. Furthermore, signaling through EGFr is modified in the context of the overall physiological setting, for instance in the presence of inflammation or infection. Different components of the secretory machinery are

regulated in response to differential activation of EGFr. A number of diseases and conditions exhibit dysregulation of intestinal fluid transport characterized by disturbances in absorption, secretion, or both. To fully address many of these conditions, it is important to understand how EGFr activation regulates intestinal fluid transport under various physiological conditions. To this end, we set out to identify transporter targets subject to regulation by EGFr under conditions that differentially activate the receptor. We have identified Na^+ , K^+ , 2Cl^- Cotransporter 1 (NKCC1), a widely expressed transporter important to chloride secretion, as being differentially regulated through EGFr activation. When EGFr is transactivated in response to the cholinergic agonist, carbachol, NKCC1 is endocytosed from its site of activity at the basolateral plasma membrane through a mechanism that requires EGFr-dependent activation of mitogen-activated protein kinase (MAPK) pathways. However, when EGFr is activated through direct exposure to the *bona fide* ligand, epidermal growth factor (EGF), phosphatidylinositide-3 kinase (PI3K) is recruited rather than MAPK and NKCC1 is not endocytosed. This divergent regulation of NKCC1 through differential activation of EGFr has implications not only for the regulation of intestinal ion and fluid transport and the treatment of their dysregulation, but also for a number of other physiological processes and pathologies involving EGFr and NKCC1.

Chapter One
Introduction

Intestinal water and electrolyte homeostasis

Maintenance of appropriate luminal fluidity is central to physiological functions throughout the mammalian gastrointestinal tract. Efficient digestion and absorption of nutrients relies on adequate hydration of chyme to facilitate interaction of enzymes with substrates and to distribute nutrients across the vast surface of the epithelium. Maintenance of mucosal pH, clearance of waste, and lubrication of the epithelium all rely on apposite secretion and absorption of water. Human gastrointestinal processes require about 8 to 9 liters of water each day; about 1 to 2 liters are obtained orally and the remaining volume is provided primarily through secretions by the stomach and intestines (1). The majority of this water is reabsorbed by the intestines and remarkably, only about 200mL of water is lost in the stool each day. Water transport is generally a passive process driven by active transport of electrolytes: secretion is driven in large part by secretion of chloride and to a lesser degree, bicarbonate, while absorption of water follows the active uptake of sodium and nutrients. As solutes are actively conducted across the epithelial mucosa, water follows the osmotic gradient passing either paracellularly through tight junctions, or transcellularly through aquaporins or other passive transport (1, 2). The importance of intestinal fluid secretion becomes evident in the pathological consequences of its absence or dysregulation, as found in hyposecretory disease such as cystic fibrosis, or hypersecretory conditions such as secretory diarrhea; the former presents with intestinal obstruction while the latter results in dehydration and both incur nutritive malabsorption (3). Furthermore, chloride secretion is critical to the normal function of a number of other organ systems outside the alimentary canal including the respiratory, renal, pancreas, and biliary systems.

Vectorial chloride transport across polarized epithelial cells is complex and dependent on the coordination of several transporters localized at both the basolateral (serosal) and apical (luminal) plasma membrane domains. The general mechanisms of chloride secretion in the intestine, illustrated in Figure 1.1, are similar to other secretory tissues and have been well-characterized (4). At the basolateral pole, chloride is taken up by intestinal epithelial cells through the sodium, potassium, 2-chloride cotransporter-1 (NKCC1) that employs the inwardly directed concentration gradient of sodium to drive electroneutral influx of two chloride ions and one potassium ion along with one sodium ion. Sodium, potassium ATPase, (Na^+/K^+ ATPase) expends ATP to establish and maintain the sodium gradient, while basolateral potassium channels allow for potassium efflux, preventing depolarization. Together these transporters facilitate an accumulation of chloride within intestinal epithelial cells beyond its electrochemical equilibrium. Secretion of chloride into the lumen is driven by the outwardly directed electrochemical chloride gradient and proceeds through apically localized chloride transporters: the cAMP-dependent cystic fibrosis transmembrane conductance regulator (CFTR), calcium activated chloride channels (CaCCs or CLCAs), or one or more members of the ClC family of chloride channels. All of these transport pathways are factors in chloride secretion and theoretically, a change in any single pathway has an impact on net chloride secretion. While CFTR was long viewed as the primary site for regulation of intestinal chloride secretion, it is now clear that NKCC1 is an important regulatory locus (5), while the role for CaCCs has been more appreciated as this family of transporters becomes more thoroughly characterized (6-8). The molecular characterization and regulation of many of these transporters is discussed in more detail later in this chapter.

There are two major and distinct pro-secretory intracellular signaling pathways regulating epithelial chloride secretion, one characterized by increases in intracellular cyclic nucleotides (cAMP and/or cGMP) and the other characterized by increases in intracellular calcium (1). These pathways are activated by a number of endogenous agents acting through endocrine, paracrine, neurocrine, and immune pathways. Furthermore, these pathways are activated by exogenous agents such as bacteria, bacterial toxins, and environmental toxins. Cyclic nucleotide-dependent secretagogues generally evoke relatively large and sustained increases in chloride secretion. The effects of a number of important endogenous secretagogues are mediated through cAMP: prostaglandin E₂ (PGE₂) and vasoactive intestinal peptide (VIP) both act through G-coupled protein receptors (GPCR) to stimulate adenylyl cyclase. Increases in cAMP lead to increased protein kinase A (PKA) activity which directly activates apical CFTR (9) and the basolateral potassium channel, KCNQ1 (10), and indirectly leads to phosphorylation and activation of NKCC1 (5). In contrast, calcium-dependent secretagogues elicit transient chloride secretion that remains limited even in the continued presence of secretory agonist (1, 11, 12). Increases in intracellular calcium result from ligation of G_q-coupled protein receptors such as the acetylcholine M₃ muscarinic and histamine H₁ receptors. Rises in intracellular calcium and the consequent activation of protein kinase C (PKC) and calmodulin-dependent kinase (CaMK) leads to activation of the basolateral potassium channel, KCNN4 (1, 13, 14), and apical calcium-dependent chloride channels (1, 15, 16). Studies examining the transient nature of calcium-dependent chloride secretion revealed inhibitory pathways involved in regulating chloride secretion (17). Inhibitory agents are as varied and diverse as secretagogues and include endogenous endocrine, paracrine, autocrine, and neurocrine agents as well as exogenous

bacterial and environmental factors (4). Inhibitors of chloride secretion may act by inhibiting increases in cyclic nucleotides or calcium and/or through inhibiting the activity of transporters involved in chloride secretion. However, when cAMP and Ca^{2+} -dependent secretagogues are added simultaneously, the effects on chloride secretion are synergistic, eliciting greater chloride secretion than would be expected with an additive effect (12). This is thought to occur through limiting negative regulators and perhaps the elimination of rate-limiting factors (1). That is, the inhibitory pathways elicited by calcium-dependent secretagogues alluded to earlier may be limited when accompanied by simultaneous cAMP-activated pathways. Furthermore, cAMP and calcium-dependent secretagogues achieve their effects through regulation of distinct components of the secretory machinery; transporter processes that may be rate-limiting in the setting of one class of secretagogue may be up-regulated by the other, accounting for the observed synergy when the two are applied in combination.

Regulation of transporters involved in epithelial chloride secretion

There appear to be five major mechanisms by which epithelial transporters are regulated, illustrated in Figure 1.2: direct modulation by cytoplasmic factors, covalent modification, altered localization, changes in protein stability, and changes in transport protein transcription and/or translation (1, 3, 4, 18). Channel activity can be modulated as changes in cytoplasmic factors directly alter their open probability. For instance, as their names suggest, calcium-activated potassium and chloride channels are sensitive to changes in intracellular calcium and binding to calcium increases their open probability allowing the efflux of potassium or chloride, respectively (4, 13-16). Secondly, transport proteins may be regulated through covalent modification, such as

phosphorylation. Phosphorylation by PKA and PKC leads to activation of epithelial CFTR (19). Phosphorylation of NKCC1 appears to play a role in modulating its activity as well (5, 20-23). While direct modulation and covalent modification may serve to acutely regulate transporter activity, *in situ*, at the plasma membrane, yet another mechanism for regulating transporter activity involves altering surface expression of transport proteins. In some instances, preformed transport protein may be stored in vesicles localized just below the plasma membrane and these vesicles are stimulated in an agonist-specific fashion to fuse with the plasma membrane, increasing the number of transporters at the surface and thereby increasing the overall rate of transport (24). Conversely, transport proteins can be retrieved from the plasma membrane through endocytosis, reducing transport. Endocytosed transporters may be available for recycling back to the plasma membrane, or degraded (25, 26). With regard to intestinal chloride secretion, transport by both NKCC1 and CFTR has been shown to be regulated through insertion and retrieval from the basolateral and apical plasma membrane respectively (24-28). Lastly, transporter expression can be regulated through changes in transcription and translation. While previously discussed mechanisms are involved in acute regulation of transport, *de novo* protein synthesis involves slower kinetics and may be responsible for more sustained responses to physiological or pathophysiological circumstances (4, 29-31).

CFTR (Cystic Fibrosis Transmembrane Regulator)

The Cystic Fibrosis Transmembrane Regulator, or CFTR, was identified as the chloride channel that is defective in cystic fibrosis patients and was first cloned in 1989 (32). Located at the luminal membrane of enterocytes, it is the predominant

channel mediating chloride efflux in the intestinal epithelium. The channel consists of 12 membrane-spanning domains that form the pore of the channel, two nucleotide-binding folds, and a large regulatory domain (R) with a number of consensus sequences for phosphorylation by several different kinases. CFTR is primarily activated through phosphorylation by PKA in response to increased cAMP, however, other second messengers such as Ca^{2+} /CaMK, PKC, and cGMP-dependent kinases may play a role in regulating CFTR. While PKC phosphorylation of CFTR does not in itself activate the channel, it may be permissive or potentiate subsequent phosphorylation by PKA. Studies in knockout mice and *in vitro* models have demonstrated that cGMP-dependent kinase is capable of directly activating CFTR. In some cell types, activation of CFTR by cAMP or cGMP-dependent phosphorylation involves cAMP-dependent exocytosis of CFTR and insertion into the luminal plasma membrane from a subapical store of preformed channels (33-35). However, it is somewhat controversial as to this mechanism of regulation occurs in intestinal epithelial cells. Patch-clamp studies with isolated rat colonic crypts and *in vitro* perfused shark rectal glands demonstrated that large increases in cAMP-dependent chloride transport occurs with very little or no change in membrane capacitance (9, 36). That is, chloride transport increased without a substantial increase in plasma membrane surface area, measured by capacitance, which might be expected if CFTR was introduced through exocytosis. However, more recent studies using surface protein biotinylation and immunofluorescence in rat jejunum revealed an increase in cell surface expression of CFTR and a shift from subapical vesicle compartments to the plasma membrane (37). CFTR participates in a multiprotein complex at the apical membrane comprised of several proteins containing PDZ-domains that are important for protein interactions. The roles for these interactions with proteins such

as sodium/ hydrogen exchanger regulatory factor (NHERF1) and the PKA-binding A-kinase anchoring protein (AKAP) are only recently becoming better understood. Recent studies in airway epithelial cells have implicated a role for NHERF1 in localizing and stabilizing CFTR at the apical membrane on epithelial cells (38). Indeed, over-expression of NHERF1 rescues $\Delta F508$ CFTR, the most common mutation in humans that is structurally functional but deficient in trafficking to the plasma membrane. Presumably, physical association of PKA with its substrates, CFTR and NHERF1 *via* AKAP likely increases the efficiency of channel opening. CFTR also serves to regulate other transporters, including activation of a basolateral potassium channel, KCNQ1, discussed later, and down-regulation of ENaC, a sodium channel important to epithelial sodium and water uptake. Thus, impaired secretion resulting from absence of the major chloride efflux pathway is compounded by down-regulation of potassium efflux and up-regulation of sodium absorption by ENaC. The critical role CFTR plays in intestinal chloride secretion is apparent in the absence of functional CFTR in cystic fibrosis patients, who present with impaired gastrointestinal function including meconium ileus in 10% of newborn CF children and obstructive gut disease later in life (38). Furthermore, the importance of CFTR is evidenced in the setting of cholera infection. Cholera toxin results in uncontrolled CFTR activity leading to profuse diarrhea and dehydration. Cholera toxin fails to elicit such a response in CFTR knockout mice and heterozygous knockout mice showed only 50% of the secretory response seen in wild type mice, lending support to the hypothesis that heterozygosity may provide resistance to the effects of cholera infection and account for the relatively high prevalence of CFTR mutations. This so-called heterozygote advantage hypothesis has not been definitively established however, and a study of patients with CF and heterozygotes suggest there is no genetic

advantage for heterozygotes as they exhibited the same chloride secretory response as healthy subjects. However, the role for CFTR in intestinal chloride secretion and cholera infection is clear and effective pharmacological inhibitors of the channel for use as antidiarrheal agents are currently in development (39, 40).

Non-CFTR Conduits for Apical Chloride Efflux

Whether or not chloride channels other than CFTR play a significant role in epithelial fluid transport is a matter of great interest with respect to potential therapeutic targets for cystic fibrosis. The role of non-CFTR chloride conductance channels is likely to be species and tissue-specific and perhaps age-dependent. Airway epithelia of mice apparently have non-CFTR channels facilitating chloride efflux, as the calcium-activated chloride conductance in CFTR (-/-) knockout mice is up-regulated and even compensates for the lack of CFTR conductance and these mice do not exhibit lung disease (41). However, these same mice present with severe gastrointestinal disorders, underscoring the critical role for CFTR in this tissue (42). Interestingly, an inbred strain of CFTR (-/-) mice has been found that does not display any adverse physiology in the intestines suggesting that under certain circumstances a functional non-CFTR chloride conductance channel is expressed in intestinal epithelium as well (43). Additional evidence for a non-CFTR chloride channel in the intestines comes from studies of the rotavirus toxin, NSP4, which induces severe diarrhea in infants and young animals. NSP4 induces calcium-mediated chloride secretion in the crypts of both non-CF and CF mouse pups (44, 45). The effect of NSP4 is not as significant in adult mice suggesting age dependence for expression of the transporter (44). The severity of CF may correlate

with relative expression of one or more non-CFTR chloride conductor(s) and may explain the poor correlation between genotype and phenotype in CF patients (18, 43).

Calcium-activated chloride channels of the CLCA family could play a role in intestinal chloride secretion. The murine channel, *mCLCA3* is found in goblet cells and appears to be involved in mucin production and/or secretion in intestinal, respiratory, and uterine epithelia. In humans, CLCA1 (a.k.a. CaCC1) and CLCA4 (a.k.a. CaCC2) have both been found in the intestines (6). *hCLCA1* is expressed most strongly in the colon, with high expression also found in the small intestines and appendix (46). The greatest mRNA expression of *hCLCA1* was found in cells at the base of the crypts, especially in goblet cells. Much lower expression of *hCLCA1* is found in the stomach, uterus, kidneys, and testis (46). There are 9 potential sites on *hCLCA1* for asparagine-linked glycosylation, 13 consensus sites for protein kinase C (PKC) phosphorylation, and 3 consensus sites for phosphorylation by Ca^{2+} /calmodulin-dependent kinase II. There are no PKA or tyrosine phosphorylation consensus sequences (6). Like *hCLCA1*, *hCLCA4* is expressed most strongly in the colon, however, relative expression in the small intestines is much lower (46). There is some controversy as to whether these CLCA proteins could serve independently in the transport of chloride. Indeed, while they are expressed in intestinal epithelia, Anderson and Welsh have reported that there are no Ca^{2+} -dependent but only cAMP-dependent Cl^- channels at the apical surface of intestinal mucosa. Defining the molecular regulation of CLCAs has been difficult as they are often not expressed in tumorigenic cell lines. They may serve as accessory proteins though, modifying the activity of CFTR. In addition to the three C-kinase phosphorylation sites, the porcine homologue of *hCLCA1*, *pCLCA1*, includes a fourth C-kinase site and an A-kinase phosphorylation consensus sequence unique to *pCLCA1*. When *pCLCA1* was

transfected into NIH/3T3 cells, the cells expressed Ca^{2+} -activated, but not cAMP-activated chloride conductance. When transfected into Caco-2 cells, which do not express *hCLCA1*, cAMP-activated chloride conductance was potentiated suggesting that this transporter can contribute to net chloride secretion in the context of other secretory machinery in intestinal epithelial cells (8).

Of the members of the CIC family of chloride transporters that may also serve in intestinal epithelial chloride secretion, particular interest has been attached to CIC-2. CIC-2 tissue distribution seems to vary across species (32). In humans, CIC-2 was found in the supranuclear compartment of colon cells with punctate staining at or near the apical membrane (47). CIC-2 has also been identified in T_{84} cells at or near the apical plasma membrane (48). CIC-2 currents are inhibited by low concentrations (0.085 - 0.17nM) of TGF- α in T_{84} cells, but potentiated by higher concentrations (8.3nM). Both effects are mediated by PI3K and PKC. The inhibitory effects of higher TGF- α concentrations appear to occur secondary to increased pH as a result of NHE activation (49). Similarly, CIC-2 has been shown to be involved with apical transport in Caco-2 cells. Some studies in T_{84} cells have shown that a treatment for constipation, lubiprostone, may activate CIC-2 without affecting CFTR activity, suggesting lubiprostone could also serve to alleviate secretory dysfunction in CF (48, 50). There is, however, some debate as to the mechanisms of CIC-2 activation and a recent study showed that lubiprostone activation of chloride conductance in T_{84} cells requires CFTR (51). Additional evidence for a possible role of CIC-2 in epithelial chloride secretion lies in the finding that cholera toxin up-regulates CIC-2 expression, presumably increasing chloride and thus, fluid secretion (52).

CIC-3 is another apically localized chloride channel with a potential for participating in epithelial chloride conductance. There is some evidence implicating

this transporter in CaMKII-activated chloride conductance in HT29 and T₈₄ cells however, the physiological role for this transporter in intestinal fluid secretion remains to be determined (32).

Yet another CIC transporter, CIC-4 has been shown to localize with CFTR at the apical plasma membrane in human intestinal epithelia. This CIC may act as a Cl⁻/H⁺ exchanger in endosomes, rather than a Cl⁻ channel (53, 54), suggesting that some CICs, like some CLCAs may participate in chloride secretory processes through modification of CFTR function, rather than contributing directly to vectorial chloride conductance.

Basolateral Potassium Channels

Chloride secretion by intestinal epithelial cells also relies on the activity of basolateral potassium channels. Efflux of potassium via basolateral potassium channels is critical for maintaining hyperpolarization of intestinal epithelial cells to sustain the driving force for chloride efflux. While the role of such potassium channels in chloride secretion has been long recognized, only recently have specific transporters been identified and characterized: a calcium-activated transporter, KCNN4 (a.k.a. K_{ca}3.1, SK4, or IK1) (55) and a cAMP-activated transporter, KCNQ1 (10) (a.k.a. KvLQT1 or Kv7.1). Recent work in KCNN4 (-/-) knockout mice demonstrated that KCNN4 is necessary and sufficient for supporting calcium-mediated chloride secretion in the epithelium of both large and small intestines (13). While colonic and jejunal tissues from KCNN4 null mice exhibited normal secretory responses in response to cAMP-dependent secretagogues, calcium mobilization failed to evoke any secretory response. Furthermore, these mice exhibited markedly dehydrated stool, likely from impaired chloride and thus water secretion, suggesting a

role for KCNN4 in normal intestinal physiology. KCNQ1 is activated in parallel with CFTR in response to increased cAMP and PKA activity. The pharmacology of KCNQ1 may be greatly influenced by another protein, KCNE3 (18). There is some data indicating possible regulation of KCNQ1 by calcium and PKC. A recent study employing KCNN4 knockout mice and a KCNQ1 specific inhibitor, 293B, demonstrated that while the secretory response to the muscarinic agonist, carbachol, was significantly attenuated in KCNN4 knockout mice, the small residual response was completely inhibited by 293B, suggesting that both potassium transporters were activated in response to carbachol, a Ca^{2+} -dependent secretagogue (14). Another study using a derivative of 293B with higher affinity for KCNQ1, HMR1556, concluded that KCNQ1 was not essential to chloride secretion as the inhibitor only partially reduced (50%) PGE_2 -induced cAMP-dependent chloride secretion in rat intestinal tissue and had no effect in guinea pig intestinal tissue (56). HMR1556 had no effect on chloride secretion in response to another cAMP-dependent agonist, epinephrine, in intestinal tissue from either rat or guinea pig. Interestingly, the synergistic secretory effect of the addition of carbachol subsequent to PGE_2 was also partially inhibited by HMR1556, providing additional evidence that KCNQ1 may be involved in cholinergic and other Ca^{2+} -activated secretory responses. Furthermore, the peak secretory effect in response to carbachol was little affected by HMR1556, rather, it was the inhibitory phase after carbachol stimulation that was most affected by HMR1556, causing the secretory effect to shut down more rapidly, suggesting that perhaps the inhibitory effect carbachol has on subsequent chloride secretion targets a different basolateral potassium channel, perhaps KCNN4 and any sustained secretion after the peak response to carbachol is due to KCNQ1 activity.

Finally, there are some reports suggesting a role for large-conductance (BK) potassium channels in chloride secretion. T_{84} cells exhibit a potassium channel that has yet to be identified, but is activated by arachidonic acid and appears to be distinct from calcium and cAMP-activated channels and has properties consistent with BK channels (32, 57, 58). Using experiments with colon and small intestinal tissue from Kca1.1 (a BK channel) knockout mice have demonstrated however, that these mice have normal secretory responses to both calcium and cAMP-dependent secretagogues despite the absence of this BK transporter (14).

NKCC1 (Sodium, Potassium, 2 – Chloride Cotransporter-1)

NKCC1 is a fundamentally important locus for regulating intestinal chloride and thus, fluid secretion. While apical chloride channels have long been viewed as the primary site for regulating chloride secretion, it has become clear that NKCC1 is a site for independent, rate-limiting regulation. Current data point towards a model in which chloride secretion is turned on through the activation of CFTR and/or other luminal chloride channels, while the magnitude of secretion is determined by NKCC1 activity (18). NKCC1 is responsive to intracellular chloride concentrations and is generally activated secondarily to apical chloride efflux. Thus, as apical chloride channels open, intracellular chloride falls, leading to activation of NKCC1. However, a number of factors influence the activity of NKCC1 including protein phosphorylation, membrane localization, and gene expression and this dynamic regulation of NKCC1 can serve to enhance or limit net chloride and fluid transport (20).

NKCC1 is phosphorylated at several threonine and serine residues. Activation and phosphorylation occur in parallel in response to a variety of secretory stimuli, including cell shrinkage, cAMP, and cholinergic stimulation (59). Furthermore,

inhibition of serine/threonine phosphatases PP1 and/or PP2A increases phosphorylation of NKCC1 and activates transport (60, 61). Consensus sequences for several kinases have been identified within NKCC1 and for many years, researchers have sought to identify the kinase responsible for activating NKCC1 (18). While PKA, PKC, protein kinase G (PKG), myosin light chain kinase (MLCK), CaMK, and mitogen activated protein kinase (MAPK) have all been demonstrated to be involved in regulating NKCC1 activity, none have been shown to directly phosphorylate the transporter. Recent studies have revealed that Ste20-related kinases, SPAK and OSR1, directly interact with NKCC1 and that phosphorylation by these kinases results in activation of the transporter (62, 63). This is a relatively new family of kinases and researchers are rapidly elucidating the molecular biology regulating their activity. They are tightly regulated by a family of chloride-sensitive kinases, known as without-lysine kinases, or WNKs. WNK1 and WNK4 are apparently sensitive to decreases in chloride concentrations and work together to activate NKCC1 through stimulating SPAK/OSR1 phosphorylation of NKCC1. WNK3 has been shown to activate NKCC1 in a cell volume independent manner that does not appear to rely on SPAK, suggesting that WNK3 may act directly on NKCC1. Alternatively, some studies suggest that WNK3 may activate NKCC1 through inhibiting protein phosphatases, or through influencing the activity of other WNK kinases. A number of interactions between SPAK and other kinases have been documented, many of which have established roles in regulating intestinal chloride secretion, including p38 MAPK and PKC. Most research into the mechanisms of WNK/SPAK/OSR1 activation of NKCC1 have been conducted in the context of cell volume control and hypertension and it will be interesting to see how these kinases are involved in intestinal epithelial chloride secretion. The consequences of

phosphorylation of specific residues on NKCC1 have yet to be determined. Phosphorylation of NKCC1 increases the affinity for bumetanide, a pharmacological inhibitor thought to interact with the ion-binding domain, suggesting that a phosphorylation-induced conformational change is necessary for ion transduction (20, 22). Additionally, phosphorylation may regulate interactions with cytoskeletal elements and transporter trafficking. Furthermore, while some phosphorylation events certainly serve to activate NKCC1, others may negatively regulate transporter activity. Ultimately, it is a balance between kinase and phosphatase activities that regulate NKCC1 phosphorylation and activity in response to the overall cellular requirements for chloride and fluid transport (20, 22).

In addition to regulation through phosphorylation, NKCC1 activity is acutely regulated through modulation of expression of NKCC1 at the plasma membrane surface. The current model postulates that a vesicular pool of preformed NKCC1 resides adjacent to the basolateral plasma membrane and can be shuttled to and from the plasma membrane as dictated by cellular needs for chloride transport. NKCC1 activity is dependent on interaction with the F-actin cytoskeleton (22, 64-66), an interaction that may be regulated through phosphorylation. Studies have shown that cAMP induces a marked increase in recruitment of NKCC1 to the basolateral surface of intestinal epithelial cells that parallels an increase in NKCC1 activity (24, 26). In T₈₄ cells, activation of PKC through PMA caused an increase in NKCC1 endocytosis and proteasome-dependent degradation, presumably leading to sustained inhibition of NKCC1 activity (25). Carbachol, a physiological PKC agonist, led to endocytosis of NKCC1, but rather than being directed toward proteasomal degradation, NKCC1 was recycled back to the plasma membrane (25). Similarly, using preparations of intestinal crypts, forskolin was shown to cause rapid expression

of NKCC1 at the plasma membrane. Subsequent addition of carbachol further increased the recruitment of NKCC1 to the plasma membrane, consistent with the synergistic effects the two secretagogues have on net chloride secretion (26). Thus, in addition to regulation of transporter open probability through phosphorylation, NKCC1 activity can be modulated through changes in expression at the plasma membrane surface.

Finally, while phosphorylation and changes in plasma membrane expression may acutely regulate NKCC1 activity, more enduring changes in cellular capacity for transport through NKCC1 can be instituted through changes in gene expression and/or protein degradation. The former is observed in the normal development of intestinal epithelial cells; secretory crypt cells lose NKCC1 expression as they progress up the intestinal villus and differentiate into absorptive enterocytes. There is evidence that the secretory capacity of enterocytes can be modulated through regulation of NKCC1 expression in response to a variety of humoral stimuli. Epidermal growth factor (EGF), tumor necrosis factor, interleukin 1- β and interleukin-6 all up-regulate NKCC1 gene and protein expression leading to increased capacity for chloride transport, while prolonged activation of PKC and proinflammatory cytokines like γ -interferon have been shown to down-regulate NKCC1 gene expression (22). In this way, the secretory capacity of enterocytes is modulated by the overall physiological setting of the intestinal epithelium and this may be particularly important in the setting of inflammation and mucosal repair. These mechanisms for chronic regulation of chloride transport may prove to be effective sites for therapeutic intervention. Certain diseases that present with chronic diarrhea might be treated using therapeutic agents that down-regulate NKCC1 expression. In addition to regulation of NKCC1 expression at the genetic level, NKCC1 protein levels can be

regulated through changes in protein degradation. As discussed earlier, some activators of PKC can result in proteasomal degradation of NKCC1, while others maintain NKCC1 in an endosomal recycling pathway. Relatively little is known about factors influencing NKCC1 protein turnover, however, studies presented later in this dissertation will address some of these mechanisms.

The Sodium Pump (Na⁺/K⁺ ATPase)

While Na⁺/K⁺ ATPase is a key component of intestinal chloride secretion, providing the electrochemical sodium gradient that serves as the driving force for symport of chloride by NKCC1, there is little evidence that tight regulation of net chloride transport is correlated with acute regulation of the sodium pump. Na⁺/K⁺ ATPase relies on ATP hydrolysis to pump sodium out of the cytosol, against its concentration gradient, across the basolateral membrane of enterocytes. Inhibition of the sodium pump with ouabain completely inhibits chloride conductance, underscoring the importance of this transporter in chloride secretion. Certain factors, such as EGF, have been shown to up-regulate transcription of Na⁺/K⁺ ATPase and there is evidence that the sodium pump is subject to proteasomal degradation; these may be points of regulation of transport, but for the most part, the pump appears to be constitutively active.

Role of EGFr in the regulation of intestinal chloride secretion

EGFr, also known as ErbB1, is a member of the ErbB family of receptor tyrosine kinases, located at the basolateral membrane of intestinal epithelia (67). Long understood to be involved in cell growth and differentiation in response to growth factors such as EGF and TGF- α (68), EGFr has come to be realized as an

important regulator of epithelial barrier function, restitution, and electrolyte transport, including chloride secretion (67, 69-71). EGFr is a dynamic signaling nexus that can be differentially activated to elicit divergent, even opposing effects on intestinal chloride transport in response to the mechanism of activation and overall physiological signaling milieu in which it is active (70, 72). In addition to activation of EGFr through direct ligand binding, stimulation of other growth factor receptors or G-protein coupled receptors (GPCR) can lead to transactivation of EGFr through the activation of small soluble kinases and/or release of endogenous EGFr ligand (73-76). Several different moieties on EGFr are amenable to phosphorylation. Importantly, our lab and others have shown that direct *versus* indirect activation of EGFr leads to differential phosphorylation of the receptor and recruitment of stimulus-specific downstream signaling pathways (72, 77). In this way, the intestinal epithelium utilizes a single receptor, EGFr, to respond to varying physiological circumstances. With regard to chloride secretion by intestinal epithelia, for instance, stimulation with the muscarinic agonist, carbachol (CCh), evokes a rapid, increase in chloride secretion made transient by subsequent inhibition of chloride secretion that is dependent on transactivation of EGFr (76). Direct stimulation with EGF also leads to inhibition of CCh-stimulated chloride secretion, however, the inhibitory effects of indirect transactivation of EGFr by CCh *versus* direct activation involve different EGFr-dependent downstream mediators and regulatory targets (77).

Acute activation of EGFr by EGF or TGF- α inhibits both calcium and cAMP-dependent chloride secretion without affecting increases in these secondary messengers in colonic epithelial cells and the mechanisms for this have been well delineated. Ligand binding of EGFr results in receptor heterodimerization with ErbB2. The p85 subunit of PI3K is recruited to the heterodimer and phosphorylated (78).

EGFr-dependent activation of PP2A leads to subsequent dephosphorylation of p85 serine residues resulting in activation of PI3K (79). Signaling from PI3-K through Akt and PKC ϵ ultimately inhibits colonic epithelial chloride transport (80), at least in part, through inhibiting a basolateral potassium channel (77). EGFr-dependent activation of phospholipase C (PLC), distinct from PKC activity, plays a role as well and inhibition of colonic epithelial chloride secretion is mediated, in part, through increases in Ins(3,4,5,6)P₄ (71). However, the details of this component of EGF signaling are not as well defined.

In addition to direct activation of EGFr through binding of *bona fide* ligand, inhibition of colonic epithelial chloride secretion by a number of signaling agents acting through diverse receptors relies on activation of EGFr. The mechanisms for EGFr activation are stimulus-specific with some relying on release of endogenous ligand, activation of small soluble kinases, or a combination of such signaling leading to transactivation of EGFr. Interestingly, the effectors and ultimate targets of inhibition downstream of EGFr are also stimulus-specific. The inflammatory cytokine, IFN γ , stimulates release of TGF α and inhibits epithelial chloride secretion through transactivation of EGFr that involves Src kinase (81). Growth hormone inhibits chloride secretion through janus kinase (JAK2) dependent transactivation of EGFr and subsequent activation of extracellular signal-regulated kinase 1/2 (ERK 1/2) (79). The best-characterized transactivation of EGFr related to inhibition of epithelial chloride secretion is that elicited by cholinergic agonists acting through M₃ muscarinic receptors.

The M₃ muscarinic receptor is a Gq Protein Coupled Receptor (GqPCR) localized to basolateral membranes of intestinal epithelial cells that responds to cholinergic agonists such as the neurotransmitter, acetylcholine and its analogue,

carbachol. Activation of M_3 receptors initially evokes an increase in intracellular calcium through release from intracellular stores leading to calcium-dependent chloride secretion in the intestinal epithelium. However, subsequent to calcium mobilization, a signaling cascade that involves the soluble tyrosine kinases, Pyk2 and Src, along with the proteinase-dependent release of $TGF\alpha$, recruits Shc and Grb2 to EGFr, leading to increased phosphorylation and activation of the receptor (73, 76, 82, 83). Similar to direct activation by EGF, this transactivation of EGFr results in inhibition of epithelial chloride secretion, however, the downstream signaling pathways recruited by activated EGFr differ from those recruited when EGFr is directly stimulated by either EGF or $TGF\alpha$. In contrast with direct activation, rather than forming heterodimers with ErbB2 as described earlier, EGFr predominantly forms homodimers in response to muscarinic agonism (78). While the p85 subunit of PI3K is recruited to these homodimers and phosphorylated, PP2A is not activated, leaving inhibitory serine residues phosphorylated and PI3K is not active (78, 79). EGFr-dependent inhibition of chloride secretion in response to carbachol is instead dependent on distinct signaling through ERK and p38 MAPK activation (82, 84) (Figure 1.3). Furthermore, rather than ultimately inhibiting a basolateral potassium efflux pathway as seen with direct activation of EGFr by EGF or $TGF\alpha$, EGFr-dependent antisecretory mechanisms in response to carbachol appear to rely, at least in part, on inhibition of an apical chloride efflux pathway (77). This differential activation of EGFr and recruitment of divergent downstream signaling is intriguing, especially in light of the fact that transactivation of EGFr in response to carbachol relies in part on release of EGFr ligand, $TGF\alpha$. In a comprehensive study, McCole and colleagues revealed that this differential signaling through EGFr is attributed to differential phosphorylation of EGFr itself (72). EGFr has a number of tyrosine

residues that are amenable to phosphorylation including sites of autophosphorylation (Y992, Y1068, Y1086, Y1148, and Y1173) as well as those that serve as substrates for modification by soluble kinases, such as Src (Y845). While EGF is the more potent agonist, treatment of T₈₄ cells with either EGF or TGF α resulted in qualitatively similar phosphorylation of EGFr tyrosine residues, with all the aforementioned tyrosines showing significant increases in phosphorylation in response to either ligand. In contrast, stimulation of T₈₄ cells with carbachol resulted in increased phosphorylation of tyrosines 845, 1086, 1148, and 1173, but had no consistent, significant effect on tyrosines 992 or 1068. This led to the hypothesis that additional signaling elicited by carbachol may be influencing EGFr activation, perhaps through increased phosphatase activity. Indeed, McCole went on to demonstrate that broad spectrum phosphatase inhibitors and specific knockdown of PTP1B uncovered phosphorylation of Y992 and Y1068 in response to carbachol and redirected signaling from ERK/p38 MAPK pathways to PI3K signaling (72).

While mechanisms of transactivation of EGFr in response to muscarinic agonism have been well defined by these recent studies, there are a number of other settings for EGFr transactivation that are less well understood. As mentioned earlier, IFN γ and growth hormone both elicit EGFr-dependent inhibition of epithelial chloride secretion (75, 81). The versatility of signaling through EGFr is highlighted in the finding that rather than serving to limit chloride secretion, several agents activate epithelial chloride secretion through EGFr-dependent mechanisms. Transactivation of EGFr is required to realize the full secretory effect in response to the GsPCR agonist, vasoactive intestinal peptide (VIP) (74). Activation of yet another class of GPCR, proteinase activated receptor-1 (PAR1) evokes chloride secretion in SCBN and T₈₄ cells through an EGFr-dependent pathway that involves many of the same

components of antisecretory signaling by other agents: EGFr transactivation through Src, subsequent activation of MAPK pathways, phosphorylation of cPLA₂, and activation of cyclooxygenase (85). Similarly, PAR2 agonists induce both cAMP and calcium-dependent chloride secretion in intestinal epithelial cells through EGFr-dependent pathways that involve ERK 1/2 and increased cyclooxygenase activity (86). Thrombin and other protease activators of PAR1 and PAR2 are elevated in inflammation and transactivation of EGFr by these receptors may contribute to IBD-associated diarrhea.

Furthermore, the transport response evoked by activation of EGFr is modulated by the context in which it is activated: in healthy tissue versus inflamed tissue, for instance. In healthy murine colonic tissue, acute pretreatment with EGF attenuates any subsequent ion transport in response to either cAMP or Ca²⁺-dependent secretagogues. Conversely, net ion transport is increased by acute pretreatment with EGF in colonic tissue from murine models of colitis, which exhibit impaired ion transport responses to both cAMP and Ca²⁺-dependent secretagogues. An elegant study demonstrated that this increased ion transport is attributable to increased electrogenic sodium absorption and while the focus of the work discussed here is electrogenic chloride secretion, this finding highlights the versatility of the EGF receptor (69).

In summary, EGFr plays a pivotal role in the regulation of intestinal chloride secretion and general ion transport. The receptor can be differentially activated, namely through variation of receptor phosphorylation, in response to specific stimuli and in context of the overall cellular environment to recruit divergent signaling pathways and impose differential regulation on relevant transporter. While some of the general mechanisms leading to differential, stimulus-specific activation of EGFr

have been delineated, in even the best characterized settings, namely binding of *bona fide* ligand and transactivation by muscarinic agonism, the ultimate targets of regulation, that is, transporters relevant to epithelial chloride secretion, and the mechanisms by which they are regulated, have not yet been clearly identified. The subject of the work presented here further elucidates differential stimulus-specific targets of EGFr-dependent antisecretory responses.

Thesis research and dissertation

My thesis research began looking at the recruitment of divergent signaling through differential phosphorylation of EGFr. As discussed earlier, many signaling events rely on EGFr in mediating their full effects on epithelial chloride secretion and differential effects of receptor activation are often realized through directing EGFr signaling through one of two pathways: PI3K or MAPK. Early on, I explored models for studying chloride secretory responses in the absence of EGFr. I investigated the use of an EGFr null, conditionally immortal intestinal epithelial cell line, however, this cell line required IFN γ in the culture media and this made interpretation of chloride secretory responses difficult, as IFN γ has been demonstrated to inhibit chloride secretion. Efforts pursuing knockdown of EGFr in established cell lines such as T₈₄ using inducible shRNAi introduced through a lentiviral vector showed promise however, these cells have proven difficult to stably transfect. In parallel with my studies of EGFr knockout and knockdown models, I pursued identifying transporters relevant to chloride secretion that were inhibited consequent to EGFr activation by different stimuli. As discussed earlier, EGFr can be differentially activated to elicit divergent stimulus-specific responses, however, the ultimate targets of regulation, that is, the transporters most directly influenced by EGFr activation have yet to be

identified. Early evidence in this vein pointed towards differential regulation of NKCC1 in response to EGFr activation through EGF *versus* transactivation of EGFr in response to carbachol. The primary focus of my thesis studies presented in this dissertation addresses these differential mechanisms for EGFr-dependent inhibition of the critically important function of epithelial chloride secretion.

The contents of Chapter One, in part or in full, are being prepared for submission for publication. (Chappell AE and Barrett KE. "Divergent regulation of NKCC1 through differential activation of EGFr: implications for intestinal ion transport" *In Preparation*. Alfred Chappell was the primary researcher and author for these chapters. Professor Kim Barrett supervised and directed the research that forms the basis for these chapters.

Figure 1.1 Mechanisms of chloride secretion in intestinal epithelial cells.

Chloride enters the cell basolaterally through secondary active transport facilitated by NKCC1. The electroneutral symport of two Cl^- ions along with one Na^+ and one K^+ . By NKCC1 is driven by the electrochemical gradient of sodium established by Na^+/K^+ ATPase which hydrolyzes ATP in order to pump three Na^+ out of the cell and two K^+ into the cell across the basolateral plasma membrane. Basolateral potassium channels allow the efflux of K^+ along its electrochemical gradient, preventing depolarization of the cell. The resulting electrochemical gradient established by the basolateral influx of Cl^- and efflux of K^+ drives the apical efflux of Cl^- via chloride channels. Diagram adapted from Barrett and Keely, *Physiology of the Gastrointestinal Tract* (Fourth Edition), 2006.

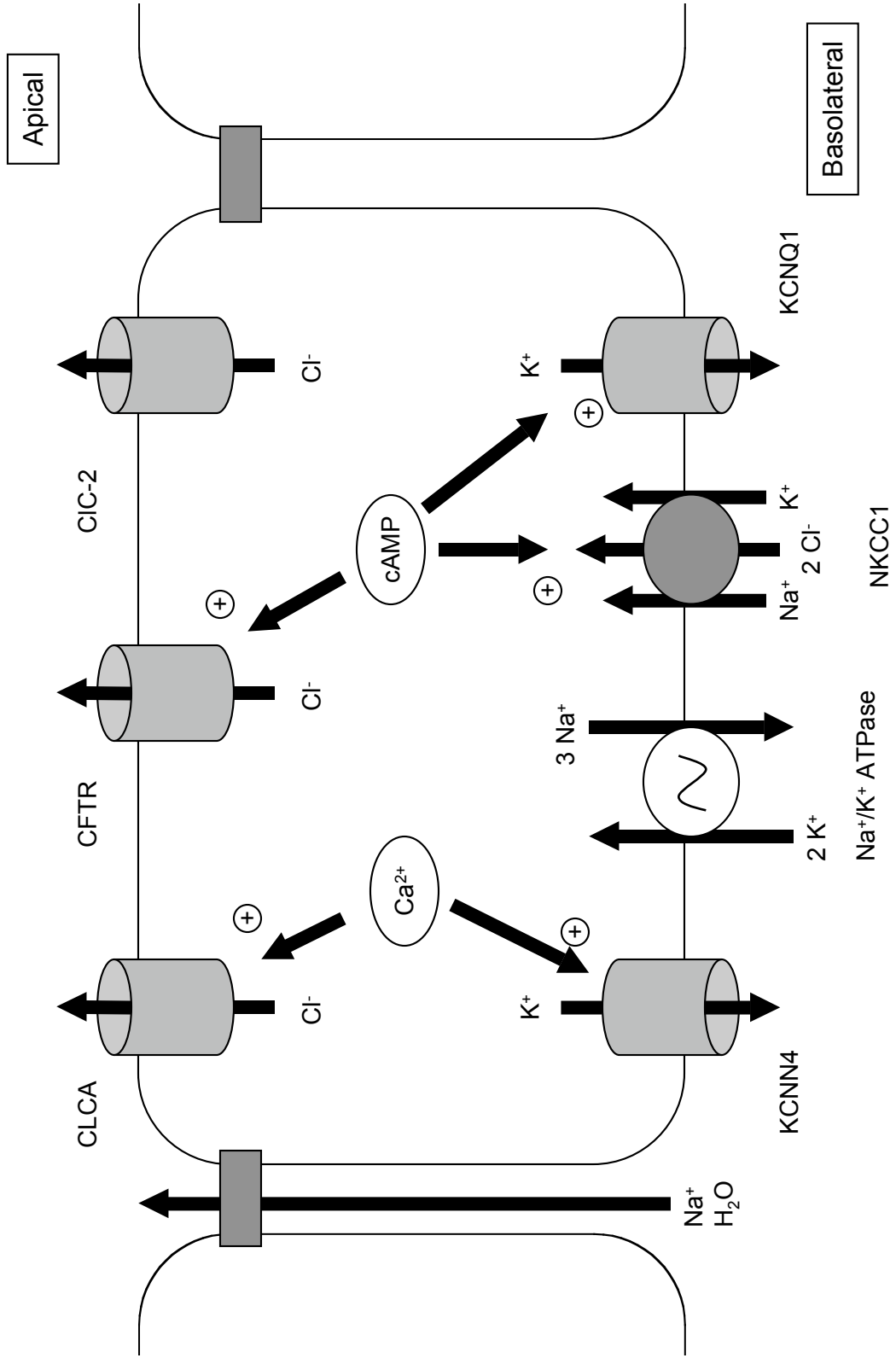

Figure 1.2 Regulation of ion channels and transporters. There are five basic mechanisms by which ion transporters, and most membrane proteins, for that matter are regulated. 1) Open probability of channels can be modulated by direct interaction with cytoplasmic factors, such as calcium. 2) Covalent modifications such as phosphorylation can modulate transporter and channel activity. 3) Transporter activity can be regulated through exocytic insertion into the plasma membrane, or endocytic retrieval. 4) Degradation of transporters can down-regulate their activity for prolonged periods. 5) Changes in the rate of transporter transcription or translation can modulate transporter abundance and thus, net transport. Transporters are quite often regulated through a number of different mechanisms.

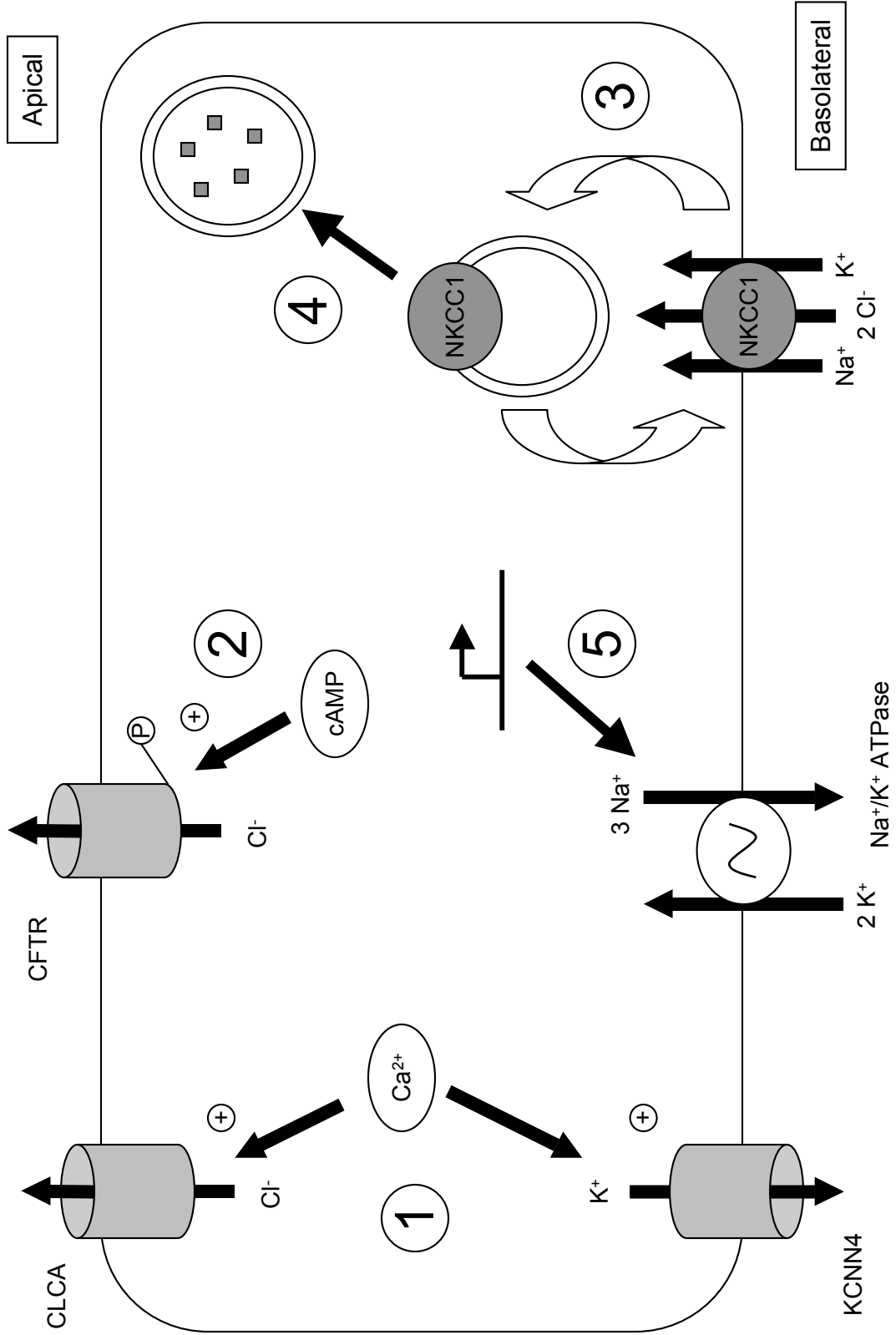
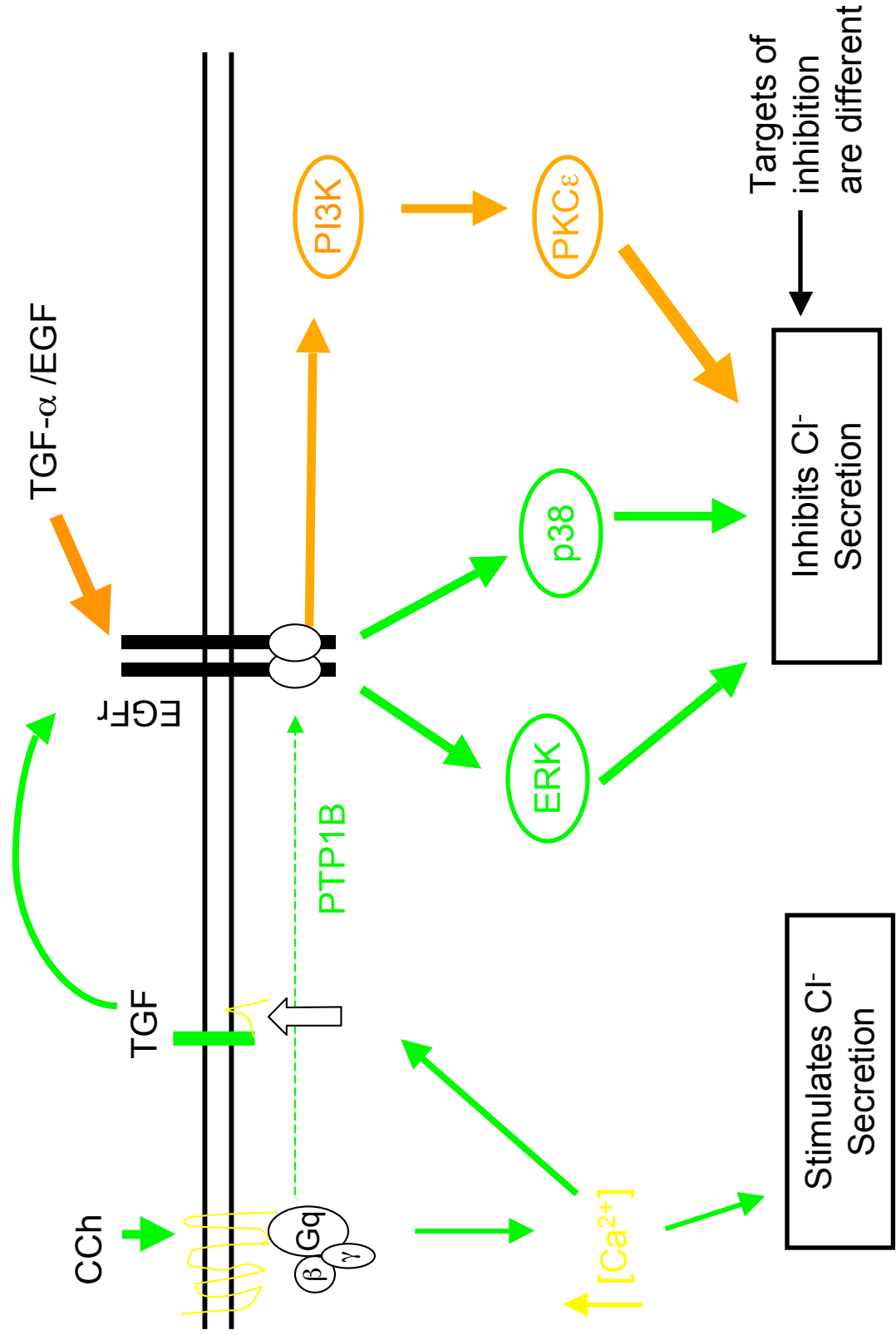

Figure 1.3 Divergent signaling through EGFr. EGFr can be differentially activated to elicit divergent downstream signaling pathways. Signaling elicited by direct activation of EGFr in response to *bona fide* ligands such as EGF or TGF α is depicted in orange. Signaling elicited by transactivation of EGFr in response to cholinergic agonism is depicted in green. When intestinal epithelial cells or tissue are treated directly with EGF or TGF α , EGFr is activated and recruits PI3K and PKC signaling to inhibit chloride secretion. When intestinal epithelial cells or tissue are treated with a cholinergic agonist, consequent increases in cytosolic calcium result in an initial stimulation of chloride secretion. However, cholinergic stimulation also results in transactivation of EGFr through the release of endogenous TGF α . EGFr is differentially activated in response to cholinergic stimuli compared with direct application of bona fide ligand, a result, in part, of increased PTP1B activity and dephosphorylation of specific tyrosine residues on EGFr. Rather than recruitment of PI3K, cholinergic transactivation of EGFr results in recruitment of MAPK signaling.



Chapter Two
Materials and Methods

Materials

All materials were research grade and obtained commercially as indicated: sulfo-NHS-SS-biotin, Neutravidin agarose, Protein G agarose (50% slurry), and glycine (Thermo Fisher Scientific, Rockford, IL); carbachol, tyrphostin AG1478, LY294002, PD98059, SB203580, MG132 (EMD Biosciences, San Diego, CA); PYR-41 (BioGenove, Rockville, MD); EGF and Millicell-HA 12mm and 30mm transwell inserts (Millipore, Billerica, MA); goat polyclonal anti-NKCC1 and mouse monoclonal anti-ubiquitin antibodies (Santa Cruz Biotechnology, Santa Cruz, CA); rabbit polyclonal anti-SUMO-1 (Cell Signaling Technology, Danvers, MA); rabbit polyclonal anti-PanSUMO (Abgent, San Diego, CA); $^{86}\text{Rb}^+$ as $^{86}\text{RbCl}$ (Perkin-Elmer, Waltham, MA); DMEM/ Ham's: F12 (1:1) media (Mediatech, Manassas, VA); and newborn and fetal calf serum (Hyclone, Logan, UT). Ringer's solution contained (in mM): 115 NaCl, 25 NaHCO_3 , 2.4 K_2HPO_4 , 0.4 KH_2PO_4 , 1.2 MgCl_2 , 1.2 CaCl_2 , and 10 glucose. Biotin stripping solution comprised 15.5mg/mL reduced glutathione (Thermo Fisher), 83mM NaCl, 10% fetal bovine serum, and 0.3% NaOH. Lysis buffer comprised of 1% TritonX-100, 20 μM NaF, 1mM each of EDTA and sodium orthovanadate (Na_3VO_4), 1 $\mu\text{g}/\text{mL}$ each of antipain, pepstatin, and leupeptin, and 0.1mg/mL PMSF. N-Ethylmaleimide (NEM) (Sigma-Aldrich, St. Louis, MO) was included (50mM) in lysis buffer in experiments assessing ubiquitination. 2X electrophoresis loading buffer consisted of 1mM Tris-HCl, pH6.8 with 4% SDS, 0.2% bromophenol blue, 20% glycerol, and 10% dithiothreitol. 1X Tris-buffered saline (TBS) contained

Cell culture

All experiments were performed using the T₈₄ human colonic epithelial cell line (passage 15 - 35). The T₈₄ cell line, derived from a human colonic carcinoma, was

first described as a model for epithelial chloride secretion in 1984 (87). T⁸⁴ cell cultures form a polarized monolayer when grown on semipermeable supports and exhibit high transepithelial resistance, similar to epithelial cells in colonic crypts. Furthermore, the cells perform vectorial chloride secretion in response to a number of physiologically relevant agonists (87, 88). The cell line has since served as a valuable reductionist model for evaluating intestinal ion transport and immunophysiology (4, 18, 88). Cells were cultured in Dulbecco's Modified Eagle Medium (DMEM)/ Ham's: F12 (1:1) media supplemented with 5% newborn calf serum in T75 culture flasks and incubated at 37°C with 5% CO₂. Cells were split 1:5 every two weeks and media was changed every 3 - 4 days. For internalization and ⁸⁶Rb⁺ influx studies, ~5x10⁵ cells were seeded onto 12mm transwell inserts. For immunoprecipitation and other western blot studies, ~10⁶ cells were seeded onto 30mm Millicell-HA transwell inserts. Cells were cultured on inserts for 10 – 20 days before using in experiments with media changed every 3-4 days, but never less than 48 hours before an experiment.

Determining internalization of NKCC1

Internalization of NKCC1 was determined using a modification of a previously described assay (25). T₈₄ cells grown on 12mm transwell inserts were rinsed with warm Ringer's solution and incubated for 1hr. at 37°C. Cells were rinsed with cold Ringer's solution on ice and basolateral surface proteins were biotinylated by incubating cells at 4°C with a basolateral solution of 0.5mg/mL sulfo-NHS-SS-biotin prepared in Ringer's solution for 30 minutes, exchanging the biotin with a fresh solution at 15 minutes. Cells were rinsed basolaterally five times with 0.5mL 100mM glycine prepared in cold Ringer's solution to remove unreacted biotin and then twice

with cold Ringer's solution to remove glycine. Cells were then exposed to basolateral 100 μ M carbachol or 100ng/mL EGF at 37°C. After treatment, cells were rinsed three times with cold Ringer's solution on ice. The remaining biotin exposed at the basolateral surface was stripped, incubating cells two times for 20 minutes on ice at 4°C with 0.8mL of biotin stripping solution on the basolateral side. Cells were then rinsed three times with cold Ringer's before being lysed on ice at 4°C for 40 minutes with 0.3mL lysis buffer. Cells were scraped from transwell membranes, transferred to microcentrifuge tubes, and centrifuged at 18,000 relative centrifugal force (rcf) for 10 minutes at 4°C. The supernatant was saved as whole cell lysate. Equal quantities of cellular proteins as determined by DC protein assay (BioRad) (~200 μ L of whole-cell lysate) were precipitated overnight with 30 μ L high binding capacity Neutravidin agarose. The agarose was washed 3X with a high salt buffer (0.1% TritonX-100, 500mM NaCl, 50mM Tris-HCl, pH7.5), followed by a final wash with a low salt buffer (10mM Tris-HCL, pH7.5). Precipitated agarose was resuspended in 30 μ L 2X loading buffer, boiled for 4 minutes, and centrifuged again at 18,000 rcf for 3 minutes. Whole cell lysates were similarly prepared with 1:1 dilution in 2X loading buffer. Precipitated proteins and those in whole cell lysates were separated by SDS-PAGE, transferred to PVDF membrane, and analyzed by western blot. An increase in Neutravidin-precipitated protein was interpreted as increased surface protein internalization. For experiments involving pharmacological inhibitors, inhibitory agents were prepared in Ringer's solution and applied bilaterally 30 minutes before biotinylation, kept apically (cold) during biotinylation and included bilaterally during 1 hour carbachol or EGF treatments at 37°C: AG1478 (1 μ M), Na₃VO₄ (500 μ M), PD98059 (20 μ M), SB203850 (10 μ M), MG132 (10 μ M). The doses chosen for all pharmacological agents were

based on our previous experiences and/or published studies using these reagents (72, 82, 84, 89).

Determining ubiquitination and sumoylation of NKCC1

T₈₄ cells grown on 30mm transwell inserts were rinsed with warm Ringer's solution and incubated for 1 hour at 37°C. Cells were then treated with appropriate inhibitors, followed by basolateral treatment with carbachol or EGF. Experiments were terminated by rinsing cells with cold Ringer's solution on ice and cells were lysed on ice for 40 minutes at 4°C with 0.5mL lysis buffer including 50mM NEM added just before lysis. Cells were scraped from transwell membranes, transferred to microcentrifuge tubes, and centrifuged at 18,000 rcf for 10 minutes at 4°C. The supernatant was saved as whole cell lysate and 20µL of each whole cell lysate prepared for electrophoresis by adding 20µL 2X loading buffer and boiling for 4min. The protein concentration of each sample was determined using DCA protein assay (BioRad) and equal amounts of protein (~300µL of whole-cell lysate) were aliquoted for immunoprecipitation. 5µg anti-NKCC1, anti-Pan-SUMO, or anti-SUMO-1 was added to each sample and rotated overnight at 4°C. 30µL of 50% Protein G agarose was added to each sample and rotated for at least 1hr. at 4°C. After rotating, the agarose beads were washed 3X with a cold solution of 1% TritonX-100 prepared in PBS, centrifuging the samples at 18,000 rcf for 30sec. between each wash. After removing the final wash from the centrifuged agarose, 30µL 2X loading buffer was added to each sample and samples boiled for 4min. Samples of whole cell lysate with equal protein and equal volumes of immunoprecipitated protein were separated by SDS-PAGE and analyzed by western blot for ubiquitin, NKCC1, or SUMO-1.

Some experiments analyzing sumoylation involved lysing cells under denaturing conditions. In these experiments, 1% lauryl sulfate (SDS) was prepared in 1X TBS and brought to a boil. At the end of treatment periods, boiling SDS was added directly onto the cells. Cells were scraped off the insert membranes, transferred to 1.5mL microcentrifuge tubes and lysates boiled 10 minutes. Lysates were then passed several times through an 18G needle. For Immunoprecipitation from denatured lysates, lysates were diluted in six volumes of 1% TritonX-100 prepared in 1X TBS in order to bind up free SDS monomer before adding the precipitating antibody.

Determining NKCC1 activity through $^{86}\text{Rb}^+$ uptake

Bumetanide-sensitive, basolateral K^+ uptake by NKCC1 was measured with $^{86}\text{Rb}^+$ as a tracer using an adaptation of a previously described method (90). Confluent monolayers of T_{84} cells grown on 12mm transwell inserts were rinsed three times with warm Ringer's solution and incubated for 1 hour at 37°C before being transferred to basolateral solutions of 100 μM CCh or 100 ng/mL EGF for 1 hour. After 1-hour treatment, solutions of 1 μM forskolin (Fsk) \pm 10 μM bumetanide prepared in Ringer's solution were applied bilaterally. Inserts were then transferred to basolateral solutions of 1 μM Fsk with 1 $\mu\text{Ci/mL}$ $^{86}\text{Rb}^+$ \pm 10 μM bumetanide prepared in Ringer's solution. After 3-min. incubation with basolateral $^{86}\text{Rb}^+$, influx was terminated by rapidly immersing inserts in ice-cold MgCl_2 (100mM prepared in 10mM Tris-HCl, pH7.5); insert membrane filters were immediately excised using a #5 cork borer and placed in 5mL Ecoscint scintillation fluid. The $^{86}\text{Rb}^+$ content of the cells was measured by standard scintillation methods. A 2 μL aliquot of 1 $\mu\text{Ci/mL}$ $^{86}\text{Rb}^+$ influx buffer was assayed by scintillation to determine the specific activity (SA) of the

influx buffer relative to $[K^+]$ (cpm/ $\mu\text{mol } K^+$). Two representative transwell inserts from the same passage of cells used in each influx experiment were lysed with 2% SDS and protein content assessed by DC protein assay (BioRad). $^{86}\text{Rb}^+$ influx data were expressed as $\mu\text{mol of } K^+ \text{ influx/ g protein/ min}$. Bumetanide-sensitive $^{86}\text{Rb}^+$ influx was calculated by subtracting the rate of influx in the presence of bumetanide (representing the bumetanide-insensitive component) from the rate of influx in the absence of bumetanide (representing total influx). In experiments using AG1478, cells were treated bilaterally with $1\mu\text{M}$ AG1478 for 30 minutes before and during treatment with carbachol.

A concern in performing these experiments, given some of the short incubation times and relatively large size of some experiments, was how to ensure incubation times were precise and accurate. In order for each sample to be handled similarly, and to ensure precision, accuracy, and reproducibility, experiments were conducted so that each sample was staggered 2 minutes ahead of the next sample. In this way, ample time was available to rinse, change treatment, excise, and otherwise handle a sample before the next sample required attention.

The contents of Chapter Two, in part or in full, are being prepared for submission for publication. (Chappell AE and Barrett KE. "Divergent regulation of NKCC1 through differential activation of EGFr: implications for intestinal ion transport" *In Preparation*. Alfred Chappell was the primary researcher and author for these chapters. Professor Kim Barrett supervised and directed the research that forms the basis for these chapters.

Chapter Three

Role of EGFr in Regulating NKCC1 Localization and Activity

NKCC1 is dynamically regulated through insertion into and retrieval from the basolateral plasma membrane of intestinal epithelial cells (22). Several studies in the early 90's indicated a role for F-actin in regulating NKCC1 activity, presumably through trafficking or anchoring of the transporter (22). A study in 1996 revealed that cAMP, a potent activator of chloride secretion induced a rapid and significant increase in surface expression of NKCC1 at the basolateral plasma membrane that paralleled the increase in chloride secretion and was linked to F-actin cytoskeleton stability (24). Recent studies have described PKC-dependent endocytosis of NKCC1. Using surface biotinylation, Del Castillo and colleagues demonstrated that the PKC activator, PMA induced PKC ϵ -dependent internalization and proteasomal degradation of NKCC1 in T⁸⁴ cells (25). These findings supported earlier studies reporting that PMA and cAMP had opposing effects on NKCC1 activity (91). A physiological PKC-activator, the muscarinic M3 receptor agonist, carbachol, also induced internalization of NKCC1, however, rather than directing the transporter towards proteasomal degradation, the transporter was recycled between the plasma membrane and an endosomal compartment (25). Remarkable fluorescent imaging in human colonic crypt preparations by Reynolds, Williams, and colleagues confirmed such regulation of NKCC1 through recycling at the plasma membrane in another model (26). In these studies, while forskolin induced a prolonged recruitment of NKCC1 to the basolateral membrane, cholinergic stimulation caused a rapid recruitment of NKCC1 followed by a cycle of endocytosis, degradation, and insertion of new transporter at the plasma membrane. Furthermore, simultaneous stimulation with forskolin and acetylcholine induced dramatic basolateral recruitment of NKCC1 and prolonged recycling, correlating with the synergistic effects of these secretagogues on net chloride

secretion. In contrast with the biotinylation studies in T₈₄ cells that described cholinergic-stimulated recycling of NKCC1 to and from an endosomal compartment, these studies in colonic crypts indicated transporter degradation and increased expression at the plasma membrane required new protein synthesis. Interestingly, cholinergic-stimulated internalization of NKCC1 in this system was apparently dependent on EGFr activation. Before the publication of this later study, I was already investigating NKCC1 as a potential site for regulation by divergent signaling through EGFr and these results agreed with my own findings, that cholinergic-stimulated endocytosis was dependent on activation of EGFr. Furthermore, my findings demonstrated that internalization was likely dependent on stimulus-specific activation of EGFr, recruitment of MAPK signaling, and did not involve transporter degradation.

Using the T₈₄ human colonic epithelial cell line, I employed a cell surface protein biotinylation assay adapted from that used by D'Andrea and colleagues (24, 25) to assess NKCC1 internalization in response to carbachol and EGF.

Results

The cholinergic agonist, carbachol, but not EGF stimulates internalization of NKCC1.

We first sought to determine if activators of EGFr, the cholinergic agonist, carbachol, or the EGFr ligand, EGF, induced internalization of NKCC1 in T₈₄ cells. The basolateral surface of T₈₄ cells was biotinylated with a cleavable biotin, then cells were treated with carbachol or EGF for up to one hour before basolaterally-exposed biotin was cleaved. After cells were lysed, biotinylated proteins in cell lysates were

precipitated using Neutravidin agarose and precipitates western blotted for NKCC1. An increase in precipitated NKCC1 was interpreted as an increase in endocytosis from the plasma membrane as the biotin-conjugate was protected from subsequent cleavage. While carbachol induced significant endocytosis of NKCC1 within 1 hour of stimulation, EGF had no effect (Figure 3.1 A-C). Several experiments included a control sample that was not subjected to glutathione stripping, thus allowing for labeling and recovery of all NKCC1 exposed at the plasma membrane surface at the start of the experiment. Based on these controls, we estimate that between 5% and 14% of NKCC1 is internalized in control cells over an hour, while 32% to 66% of NKCC1 is internalized in response to a one-hour treatment with carbachol.

Cholinergic-stimulated internalization of NKCC1 requires transactivation of EGFr.

Inhibition of epithelial chloride secretion consequent to cholinergic stimulation requires activation of EGFr. As internalization of NKCC1 could certainly serve to limit chloride secretion, we next sought to determine if cholinergic-stimulated internalization of NKCC1 is dependent on EGFr activation. To determine if EGFr activation is required for cholinergic-stimulated internalization of NKCC1, we performed surface-protein biotinylation experiments using a cleavable biotin conjugate to assess NKCC1 internalization in response to carbachol in the presence or absence of the EGFr kinase inhibitor, AG1478. While carbachol alone induced significant internalization of NKCC1 in T₈₄ cells, pretreatment with AG1478 prevented internalization, suggesting that transactivation of EGFr is required for carbachol-stimulated internalization of NKCC1 (Figures 3.2 A-C). Interestingly, EGF itself did not induce internalization of NKCC1 (Figure 3.1 A-C), indicating that while its activity

is required for cholinergic-stimulated internalization, activation of EGFr alone is not sufficient to effect internalization. A key distinction between activation of EGFr through direct ligand binding and transactivation by carbachol is the recruitment of phosphoinositide 3-kinase (PI3K) in response to direct ligand binding. The failure of EGF to stimulate NKCC1 internalization could have been the result of antagonistic signaling through PI3K. To test this possibility, internalization of NKCC1 in response to basolateral EGF was assessed in the presence and absence of the PI3K inhibitor, LY294002. T₈₄ cells were pretreated with LY294002 for 30 minutes before basolateral biotinylation and treatment with EGF. However, inhibition of PI3K failed to uncover an effect of EGF on NKCC1 internalization (data not shown). Thus, the failure of EGF to stimulate NKCC1 internalization is likely not the result of antagonistic PI3K signaling, but may instead reflect the inability of direct EGFr ligand binding to elicit the distinct EGFr-related signaling that occurs in carbachol-treated cells.

Cholinergic stimulation inhibits NKCC1 activity in T₈₄ cells, while EGF has no effect.

To determine if carbachol-stimulated internalization of NKCC1 corresponds to any change in NKCC1 activity, we assessed NKCC1 activity using ⁸⁶Rb⁺ as a tracer for K⁺ transport. Using 1μM forskolin and 10μM bumetanide to assess cAMP-dependent NKCC1 activity, we found that while incubating T₈₄ cells with EGF for 1 hour before treating them with forskolin had no effect on NKCC1 activity, treating cells with carbachol significantly reduced subsequent forskolin-stimulated NKCC1 activity (Figure 3.3), thus correlating cholinergic-stimulated internalization of NKCC1 with a decrease in transporter activity.

Cholinergic-stimulated inhibition of NKCC1 activity in T₈₄ cells is dependent on transactivation of EGFr.

To determine if cholinergic-stimulated inhibition of NKCC1 activity was dependent on transactivation of EGFr, as was seen with NKCC1 internalization, forskolin-stimulated, bumetanide-sensitive, basolateral ⁸⁶Rb⁺ influx was determined in the presence and absence of the EGFr-kinase inhibitor AG1478. Consistent with previous results, 1-hour pretreatment of T₈₄ cells with carbachol inhibited subsequent activation of NKCC1 in response to forskolin. However, incubating the cells with AG1478 before stimulation with carbachol partially reversed the inhibitory effect on NKCC1 activity, indicating that transactivation of EGFr is required for the cholinergic agonist to exert its inhibitory effects on NKCC1 (Figure 3.4). This too, correlates cholinergic-stimulated internalization of NKCC1 with an inhibition of transporter activity.

Carbachol-stimulated NKCC1 internalization is dependent on tyrosine phosphatase activity.

We have previously demonstrated that divergent activation of EGFr induced by carbachol *versus* EGF reflects increased tyrosine phosphatase activity in response to carbachol, leading to specific EGFr dephosphorylation and altered downstream signaling. Since carbachol-stimulated internalization and inhibition of NKCC1 appeared to be dependent on EGFr activation, yet direct stimulation with EGF did not induce NKCC1 internalization or inhibit activity, we sought to determine if EGFr-dependent internalization of NKCC1 in response to carbachol was the result of increased tyrosine phosphatase activity. NKCC1 internalization was assessed in response to 1-hour basolateral treatment with carbachol in the presence or absence

of the tyrosine phosphatase inhibitor, sodium orthovanadate (Na_3VO_4). Internalization of NKCC1 in response to carbachol was inhibited by sodium orthovanadate (Figure 3.5), suggesting that tyrosine phosphatase activity is required for internalization of the transporter, perhaps as a result of its role in altering the phosphorylation state of EGFr and redirecting EGFr signaling (72).

Carbachol-stimulated NKCC1 internalization is dependent on ERK and p38 mitogen-activated protein kinase (MAPK).

Two key signaling mediators that lie downstream of EGFr activated in response to carbachol are ERK and p38 MAPK. Both have been implicated in the inhibitory effect of carbachol on epithelial chloride secretion, resulting in the characteristically transient burst of chloride secretion observed in response to carbachol (82, 84). To further characterize the mechanisms of carbachol-stimulated internalization of NKCC1, we assessed this response in the presence or absence of the MEK inhibitor, PD98059, and the p38 MAPK inhibitor, SB203580. Both PD98059 (Figure 3.6 A-C) and SB203580 (Figure 3.7 A-C) inhibited internalization of NKCC1 in response to carbachol. While PD98059 and SB203580 alone increased internalization of NKCC1, carbachol failed to significantly induce additional internalization, suggesting that these kinases may play a role in mediating the effect of cholinergic-stimulation on NKCC1 internalization.

The proteasome inhibitor, MG132, inhibits carbachol-stimulated internalization of NKCC1, however, neither carbachol nor EGF induce degradation of the transporter.

While western blots for total NKCC1 in whole cell lysates did not indicate any degradation of NKCC1 in response to either carbachol or EGF (Figure 3.1 B), degradation of NKCC1 could reduce recovery of biotinylated transporter and mask true rates of internalization. If EGF did induce internalization of NKCC1, but endosomes were directed to degradative pathways, internalized biotin-conjugated NKCC1 may not be recoverable. To mitigate this, we repeated internalization experiments in the presence of the proteasome inhibitor MG132. Preincubation of T₈₄ cells with MG132 had no effect on recovered biotinylated NKCC1 in response to EGF, indicating that the apparent failure of EGF to induce internalization of NKCC1 was not due to proteasome-dependent degradation (Figure 3.8). Nor did MG132 pretreatment increase recovery of internalized NKCC1 in response to carbachol, as might be expected if NKCC1 was being directed to proteasomal degradation; rather, the proteasome inhibitor unexpectedly decreased internalization of NKCC1 (Figure 3.8). While carbachol alone induced a significant increase in internalization, in the presence of MG132, carbachol failed to cause any significant change in internalization compared with MG132 alone, suggesting proteasome activity is required in some capacity for internalization of the transporter. Neither EGF nor carbachol caused any significant change in total cellular NKCC1 either in the presence or absence of MG132.

Discussion

The studies presented here identify NKCC1 as a site of EGFr-dependent regulation of intestinal chloride secretion, through control of NKCC1 localization resulting from stimulus-specific activation of EGFr. Stimulation of T₈₄ cells with carbachol results in EGFr-dependent internalization of NKCC1 that is paralleled by a

decrease in cAMP-dependent NKCC1 activity. Direct stimulation with EGF alone, however, had no effect on NKCC1 localization or activity. The divergent signaling elicited through EGFr by carbachol stimulation *versus* direct stimulation with EGF alone is likely the consequence of increased tyrosine phosphatase activity resulting in differential phosphorylation of EGFr. Activation of EGFr by carbachol stimulation is characterized by the predominant recruitment of ERK and p38 MAPK pathways rather than PI3-K signaling evoked by EGF or TGF α alone. Consistent with differential effects on internalization through divergent EGFr signaling, in these studies, carbachol-stimulated internalization of NKCC1 relied on tyrosine phosphatase activity and signaling through ERK and p38-MAPK. We considered that PI3-K signaling effected by stimulation with EGF alone might inhibit simultaneous signaling that would otherwise result in internalization of NKCC1, but the PI3-K inhibitor, LY293003, had no effect on NKCC1 internalization in response to EGF (data not shown).

Consistent with previous studies, carbachol-stimulated internalization of NKCC1 does not result in degradation of the transporter, and NKCC1 is likely destined to be recycled back to the plasma membrane. However, the internalization of NKCC1 in response to carbachol does appear to be dependent on proteasome activity, as it is blocked by the proteasome inhibitor, MG132. As NKCC1 is not degraded, the exact nature of the role of the proteasome is unclear at this time. While certainly well established for its role in protein degradation, the proteasome has also been implicated in effecting the endocytosis of plasma membrane proteins independently of degradation (92-94). Whether internalization is the result of direct interaction of the proteasome with NKCC1, or its effect on an associated protein will be a subject for further investigation. Chapter Four presents a discussion of the

regulation of NKCC1 through covalent modification by ubiquitin and small ubiquitin-like modifier (SUMO) and posits another hypothesis that may explain the effect of MG132.

The contents of Chapter Three, in part or in full, are being prepared for submission for publication. (Chappell AE and Barrett KE. "Divergent regulation of NKCC1 through differential activation of EGFr: implications for intestinal ion transport" *In Preparation*. Alfred Chappell was the primary researcher and author for these chapters. Professor Kim Barrett supervised and directed the research that forms the basis for these chapters.

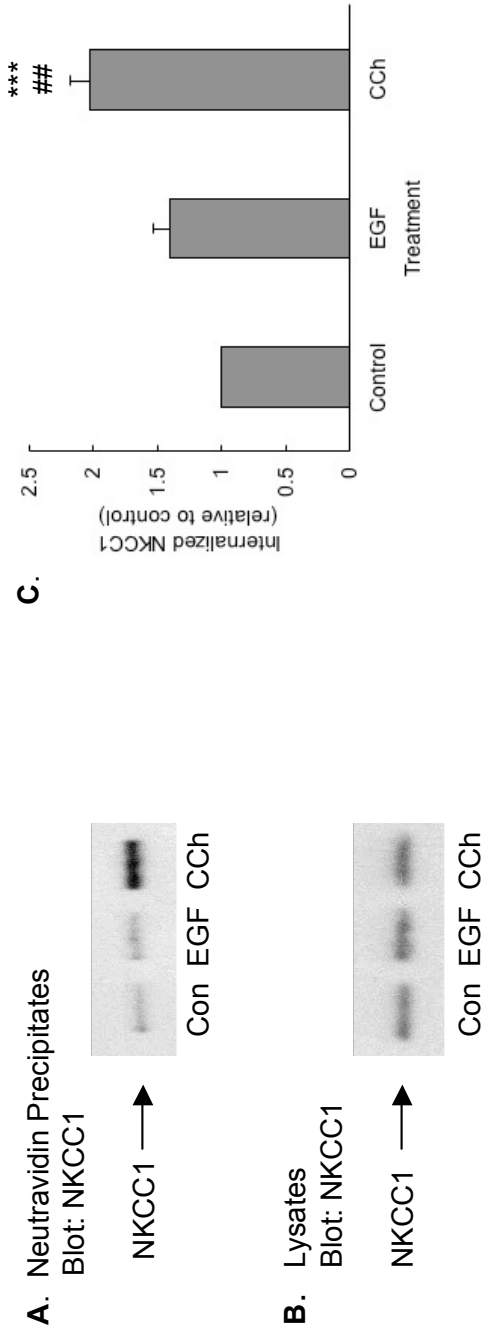

Figure 3.1 Carbachol stimulates internalization of NKCC1 while EGF does not. The basolateral surface of T_{84} cells was biotinylated prior to basolateral treatment for 60 minutes with Ringer's (control), 100ng/mL EGF prepared in Ringer's, or 100 μ M carbachol prepared in Ringer's. Any biotin remaining at the surface after treatment was subsequently stripped and internalized NKCC1 assessed through Neutravidin precipitation and western blot analysis using a NKCC1-specific antibody. *A*, representative NKCC1 western blot of Neutravidin precipitates. *B*, representative NKCC1 western blot of whole cell lysates. *C*, densitometric analysis of internalized NKCC1 (Means \pm SEM; statistical significance determined using ANOVA, with Tukey-Kramer Multiple Comparisons post-test: *** $p < 0.001$ versus control, ## $p < 0.01$ versus EGF, $n = 11$).

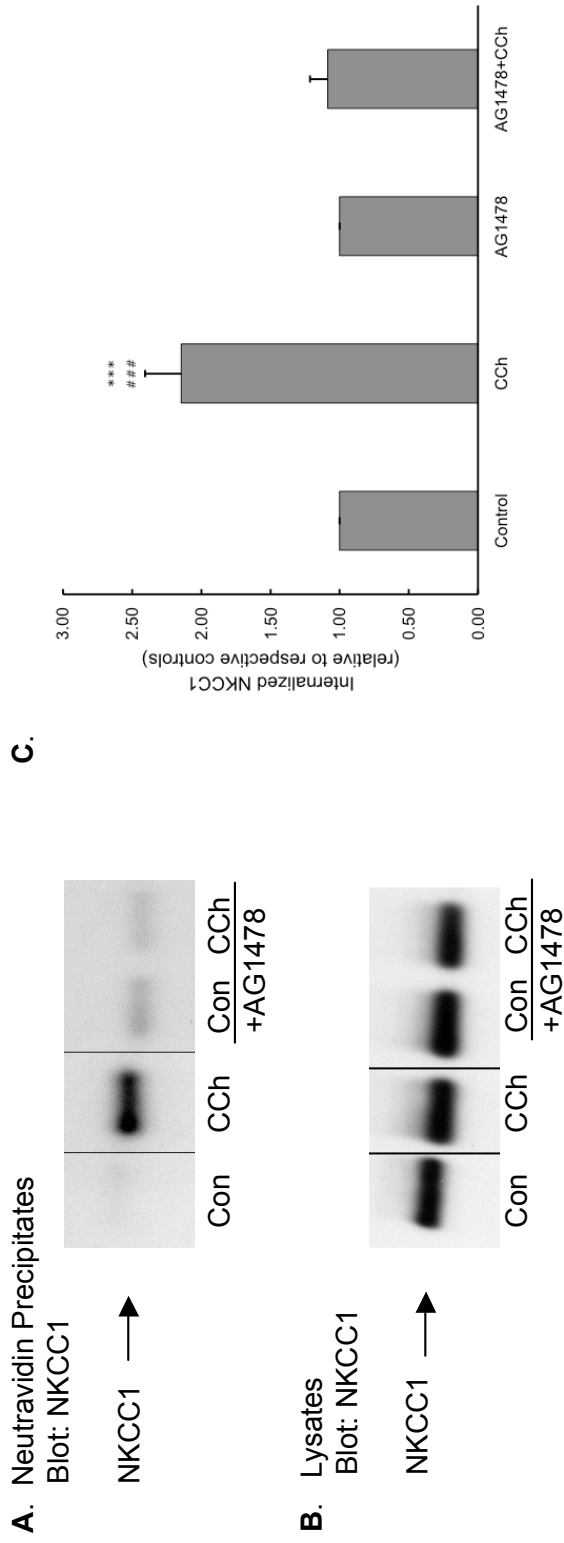

Figure 3.2 Carbachol-stimulated internalization of NKCC1 requires transactivation of EGFr. T84 cells were preincubated for 30 minutes bilaterally with the EGFr inhibitor, AG1478 (1 μ M), before assessing internalization of NKCC1 in response to carbachol using surface biotinylation. AG1478 was kept apically during basolateral biotinylation and bilaterally during carbachol treatment. A, representative anti-NKCC1 western blot of Neutravidin precipitates. B, representative anti-NKCC1 western blot of whole cell lysates showing comparable total NKCC1 in each sample. C, densitometric analysis of internalized NKCC1 (Means \pm SEM; statistical significance determined using ANOVA, with Tukey-Kramer Multiple Comparisons post-test, ***p<0.001 versus control, ###p<0.001 versus AG1478+CCh, n=6). The vertical lines in Panels A and B represent points where irrelevant bands were excised from the gel image. However, all bands shown are from the same gel image in each case.

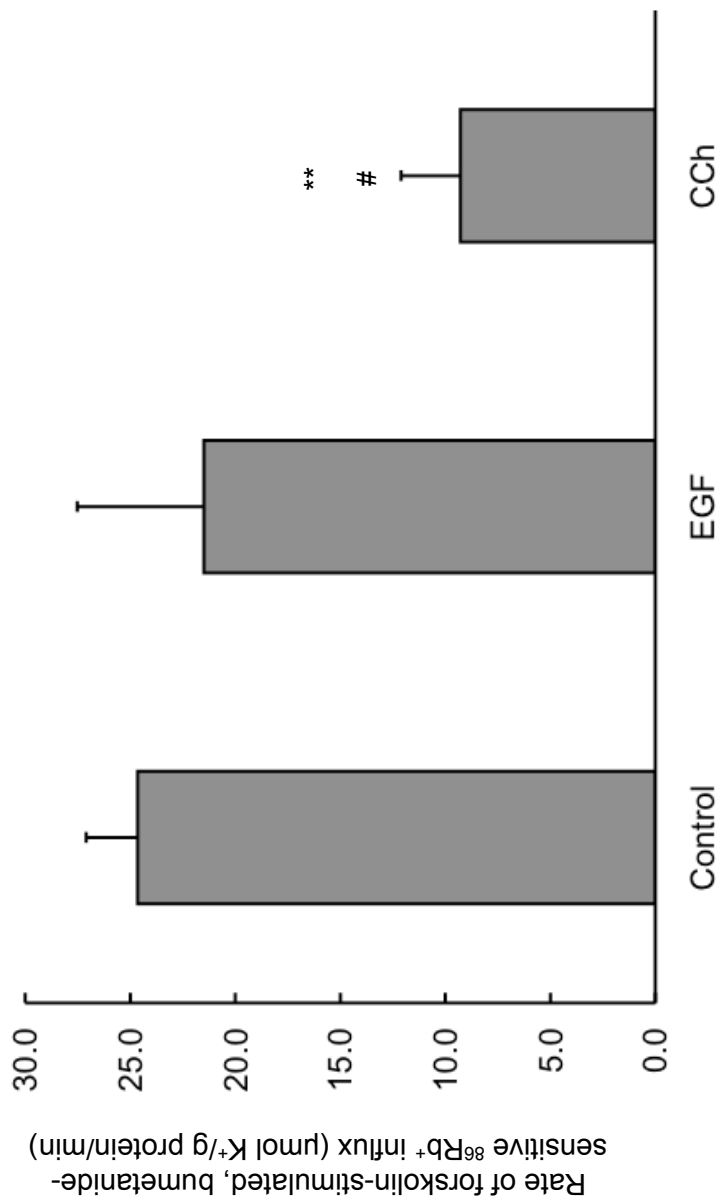

Figure 3.3 Cholinergic stimulation inhibits NKCC1 activity, however, EGF does not. T84 cells were pretreated with carbachol (100 μM) or EGF (100ng/mL) for 1 hour before treating for 10 minutes with forskolin (1 μM) in the presence or absence of bumetanide (10 μM). $^{86}\text{Rb}^+$ influx was assessed during the final 3 minutes of forskolin stimulation. Data are reported as Means \pm SEM; statistical significance determined using repeated measures ANOVA, with Tukey-Kramer Multiple Comparisons post-test, ** $p < 0.01$, vs. control # $p < 0.05$ vs. EGF; $n = 4$.

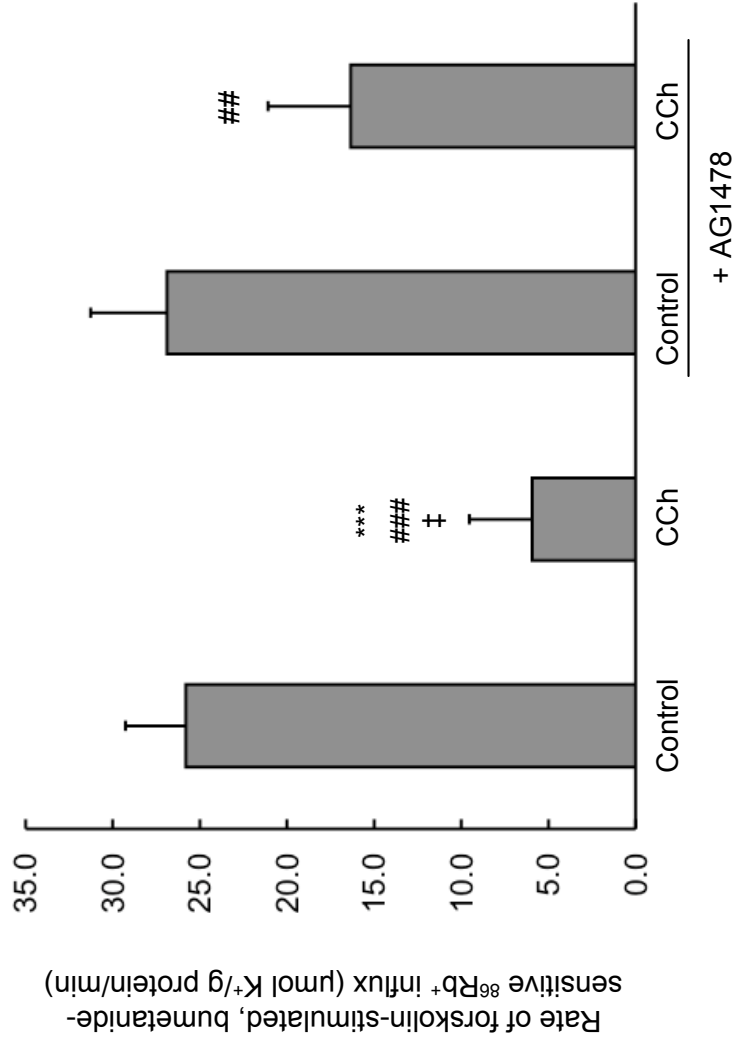

Figure 3.4 Cholinergic- stimulated inhibition of NKCC1 activity requires transactivation of EGFr. T84 cells were incubated for 30 minutes with or without $1\mu\text{M}$ AG1478, then stimulated basolaterally for 1 hour with carbachol ($100\mu\text{M}$) \pm AG1478 for 1 hour before treating for 10 minutes with forskolin ($1\mu\text{M}$) in the presence or absence of bumetanide ($10\mu\text{M}$). $^{86}\text{Rb}^+$ influx was assessed during the final 3 minutes of forskolin stimulation. Data are reported as Means \pm SEM; statistical significance determined using repeated measures ANOVA, with Tukey-Kramer Multiple Comparisons post-test: *** $p < 0.001$ vs. Control; ### $p < 0.001$, ## $p < 0.01$ vs. AG1478; † $p < 0.05$ vs. AG1478+CCCh.

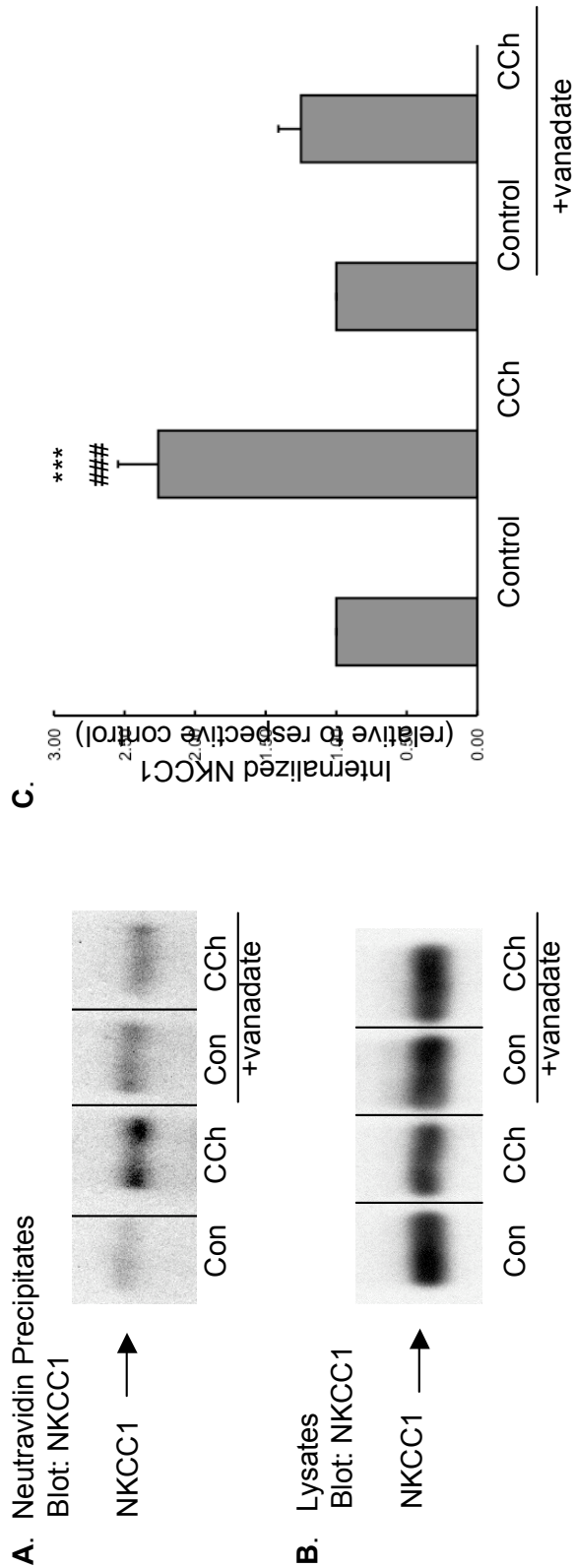

Figure 3.5 Carbachol-stimulated internalization of NKCC1 is dependent on tyrosine phosphatase activity. T_{84} cells were pretreated with the tyrosine phosphatase inhibitor, sodium orthovanadate (Na_3VO_4 , 500 μM), before assessing internalization of NKCC1 in response to carbachol using surface biotinylation. **A**, representative anti-NKCC1 western blot of Neutravidin precipitates. **B**, representative anti-NKCC1 western blot of whole cell lysates showing comparable total NKCC1 in each sample. **C**, densitometric analysis of internalized NKCC1 expressed relative to respective controls (Mean \pm SEM; statistical significance determined using ANOVA, with Tukey-Kramer Multiple Comparisons post-test $***p < 0.001$ vs. control, $###p < 0.01$ vs. CCh+Van, $n=6$). The vertical lines in Panels A and B represent points where irrelevant bands were excised from the gel image. However, all bands shown are from the same gel image in each case.

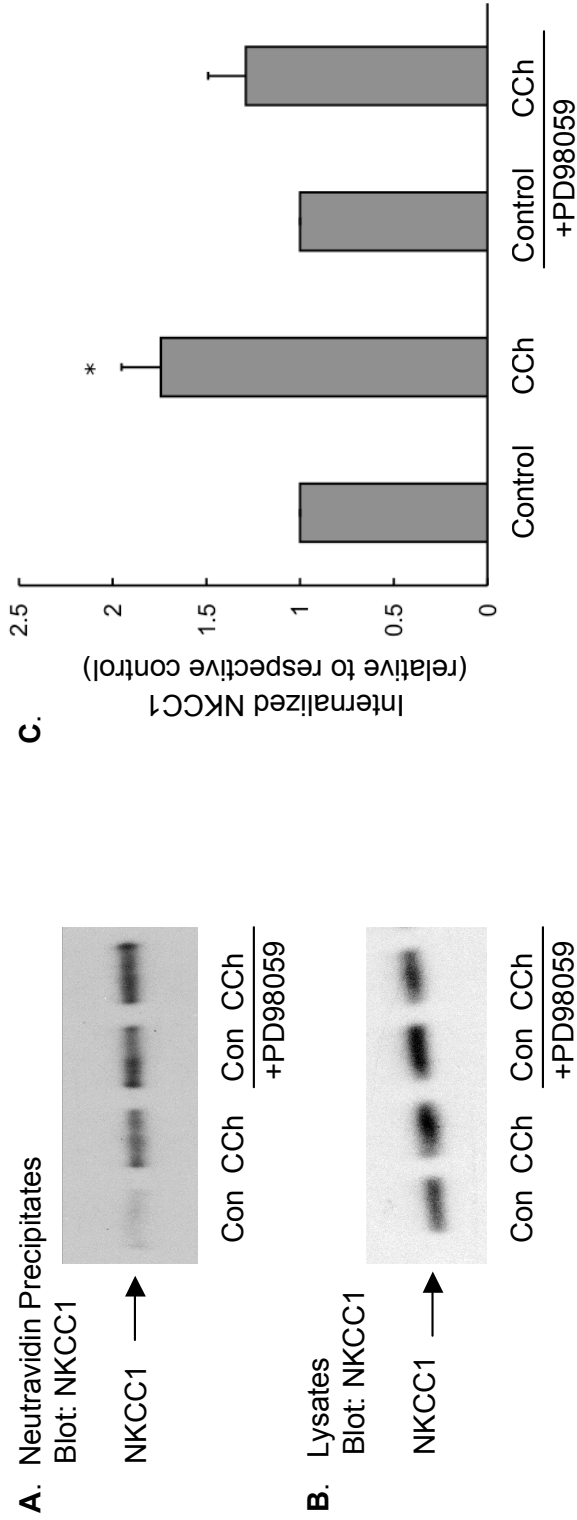

Figure 3.6 Cholinergic-stimulated internalization of NKCC1 may depend on activation of ERK MAPK. T84 cells were preincubated with the MEK inhibitor, PD98059 (20 μ M) before they were basolaterally stimulated with carbachol (100 μ M) for 1 hour. While PD98059 alone induced internalization of NKCC1, carbachol failed to significantly stimulate additional internalization, suggesting that ERK MAPK may be involved in mediating this effect. *A*, representative NKCC1 western blot of Neutravidin precipitates. *B*, representative western blot of total NKCC1 in cell lysates. *C*, densitometric analysis of internalized NKCC1 expressed relative to respective controls (Means \pm SEM; statistical significance determined using ANOVA, with Tukey-Kramer Multiple Comparisons post-test, * p <0.05 vs. control; *C*, n =5).

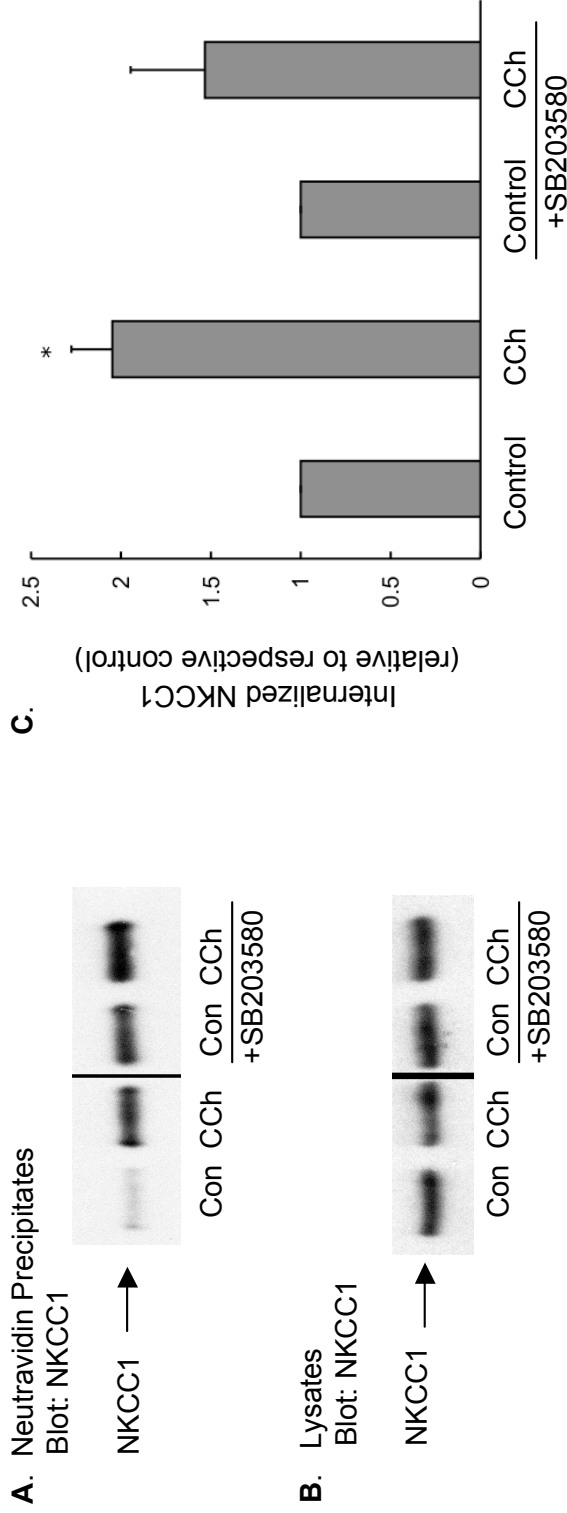

Figure 3.7 Cholinergic-stimulated internalization of NKCC1 may depend on activation of p38 MAPK. T84 cells were preincubated with the p38 MAPK inhibitor, SB203580(10 μ M) before they were basolaterally stimulated with carbachol (100 μ M) for 1 hour. While SB203580 alone induced internalization of NKCC1, carbachol failed to significantly stimulate additional internalization, suggesting that ERK MAPK may be involved in mediating this effect. A, representative NKCC1 western blot of Neutravidin precipitates. B, representative western blot of total NKCC1 in cell lysates. C, densitometric analysis of internalized NKCC1 expressed relative to respective controls (Means \pm SEM; statistical significance determined using ANOVA, with Tukey-Kramer Multiple Comparisons post-test, * p <0.05 vs. control; C, n =4). Vertical lines in figures A and B indicate where irrelevant bands were excised from the gel image, however, all bands in each figure are from the same respective gel images.

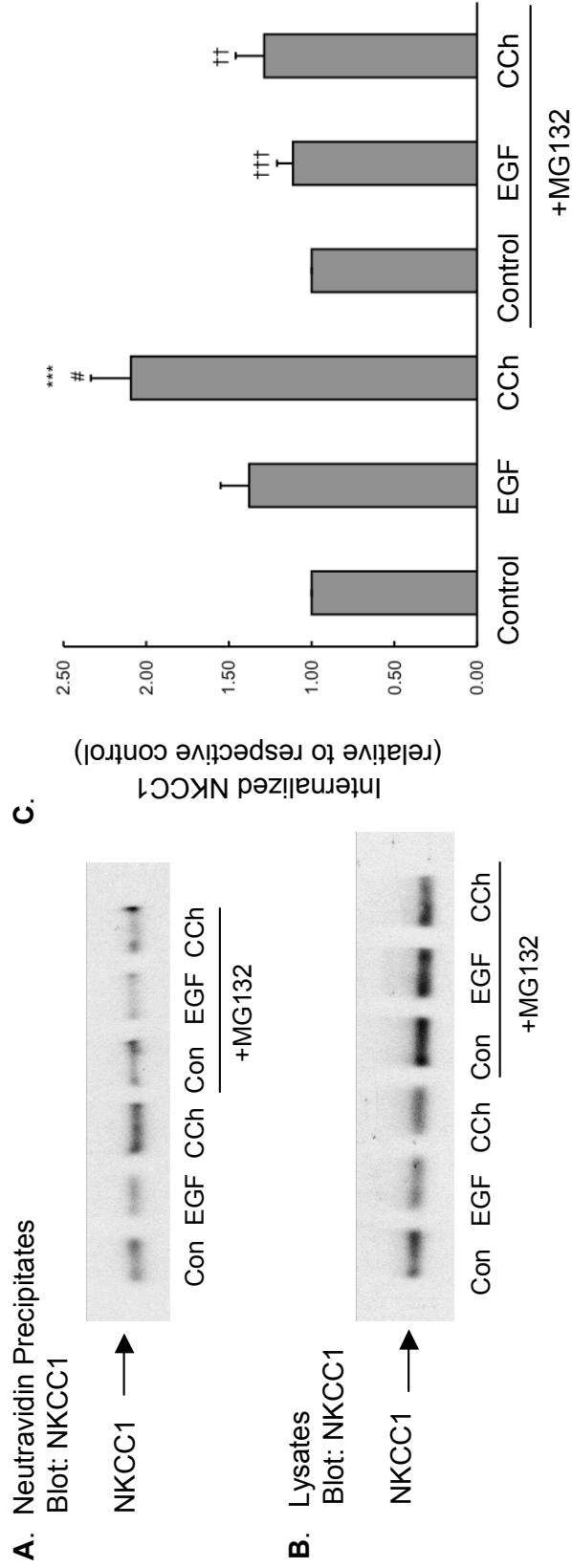

Figure 3.8 NKCC1 is not subject to proteasomal degradation in response to either EGF or carbachol, but carbachol-stimulated internalization of NKCC1 is proteasome-dependent. Internalization of NKCC1 was assessed using surface biotinylation in T_{84} cells in response to 100ng/mL EGF or 100 μ M carbachol, in the presence or absence of the proteasome inhibitor, MG132 (10 μ M). As previously observed, while carbachol induced a significant increase in internalized NKCC1, EGF did not. MG132 had no significant effect on NKCC1 internalization in response to EGF, but in the presence of MG132, carbachol fails to induce significant internalization compared with MG132 alone. A, representative anti-NKCC1 western blot of Neutravidin precipitates B, representative western blot of NKCC1 in whole cell lysates. C, densitometric analysis of internalized NKCC1 expressed relative to respective controls (Mean \pm SEM; statistical significance determined using ANOVA, with Tukey-Kramer Multiple Comparisons post-test, *** $p < 0.0001$ versus control, # $p < 0.05$ versus EGF, ††† $p < 0.001$, †† $p < 0.01$ vs. CCh, $n = 7$).

Chapter Four

The Regulation of NKCC1 Through Covalent Modification with Ubiquitin and Small Ubiquitin-like Modifier

Ubiquitin, and its cousin, SUMO (small ubiquitin-like modifier), are important regulators of protein localization, stability, and function. These small (~20kDa), structurally similar proteins covalently modify target proteins at specific lysine residues. Ligation with ubiquitin or SUMO alters protein-protein interactions or protein conformations thereby affecting protein trafficking and/or activity (95). Ubiquitin has long been associated with targeting modified proteins for endocytosis and proteasome-dependent degradation, but has also been demonstrated to play a role in lysosomal degradation as well as non-degradative endocytosis (96, 97). While the mechanisms for conjugation are similar and it is structurally homologous, the effects of SUMO modification are less well understood and appear to be more diverse than those of ubiquitin (98). Furthermore, there is a great deal of crosstalk between ubiquitin and SUMO conjugating systems (99). As they both modify lysine residues, ubiquitin and SUMO may at times act antagonistically, competitively modifying the same lysine on a protein (98, 99). Alternatively, SUMO-modification may target a protein for ubiquitination, serving as a recognition tag for ubiquitin E3 ligases (99). SUMO itself can be ubiquitinated or serve as a site for ubiquitination of a sumoylated protein (99). Additionally, ligases involved in ubiquitination can be modified by SUMO (99).

There are several examples in which transporters responsible for trafficking solutes between the cytosol and the extracellular environment are regulated through modification by addition of ubiquitin or SUMO: the two-pore domain potassium channel, K2P1 is inactive when sumoylated at a single lysine residue and has been shown to be tightly regulated through reversible sumoylation (100); the epithelial sodium channel, ENaC is internalized upon polyubiquitination (101) and may also be regulated by SUMO as it associates with the E2 SUMO-1 conjugation enzyme, Ubc9

(102); the voltage gated sodium channel Na(v)1.5 is ubiquitinated by the E3 ligase, Nedd4 (101); monoubiquitination of the potassium channel, ROMK1, reduces surface expression (101); CIC-5 is ubiquitinated in a Nedd4-2 dependent manner (101); connexin43 is internalized and degraded upon polyubiquitination (89); and activity of the glucose transporters, GLUT1 and GLUT4, is regulated through modulation of transporter abundance by Ubc9 (103). Furthermore, there are examples of transporter ubiquitination in response to EGF stimulation, most notably, a recent study in rat liver epithelial cells demonstrated that upon stimulation with EGF, connexin43 is ubiquitinated, internalized, and targeted for proteasomal degradation via a MAPK dependent mechanism (89). We hypothesized that the effects of EGFr activation on epithelial chloride secretion may be mediated by ubiquitin and/or SUMO modification of relevant transporters and set out to determine if key transporters involved in epithelial chloride secretion were modified by ubiquitin and/or SUMO in response to EGFr activation.

Results

We initially looked at sumoylation of transporters in response to EGF in T₈₄ cells. T₈₄ cells were stimulated with EGF for a variety of times ranging from 1 to 10 minutes. Cell lysates were analyzed by western blot for sumoylated proteins using a Pan-SUMO antibody that recognizes three isoforms of human SUMO (SUMO-1, SUMO-2, and SUMO-3). A number of bands were revealed by western blot, including a prominent smear correlating with proteins with molecular masses \geq 150kDa (Figure 4.1 A and B). Sumoylation appeared to occur early and decrease over time.

As there appeared to be an abundance of sumoylated protein(s) with high molecular mass, we proceeded to determine if key, high molecular mass, transporters

involved with epithelial chloride secretion with were sumoylated: CFTR (mw ~170kDa), NKCC1 (mw ~170kDa), and Na⁺/K⁺ ATPase (α -subunit mw ~90kDa). After stimulation with EGF, cells were lysed and lysates were immunoprecipitated using a Pan-SUMO antibody. Immunoprecipitates were then analyzed by western blot using antibodies directed against specific transporters. While neither Na⁺/K⁺ ATPase nor CFTR were detected in Pan-SUMO immunoprecipitates, a 57% increase in NKCC1 was observed in Pan-SUMO immunoprecipitates within 1 minute of EGF stimulation (Figure 4.2 A and B). The modification appeared to be rapid and transient, with a dramatic increase observed at 1 minute, but no effect seen after 3 minutes of stimulation with EGF (Figure 4.2 A and B).

Lysis under the conditions described are non-denaturing, so it was possible NKCC1 could be co-precipitated with SUMO or a different SUMO-modified protein without being covalently modified itself. To address this possibility, experiments were repeated using a boiling solution of 1% sodium dodecylsulfate (SDS) to terminate cell responses, simultaneously lysing the cells while denaturing proteins and disrupting any non-covalent protein association. The Pan-SUMO antibody effectively precipitated NKCC1 under these conditions, indicating NKCC1 is likely covalently linked with SUMO (Figure 4.3).

To confirm that the EGF receptor is involved in mediating the observed increase in SUMO-associated NKCC1, the experiment was repeated using T₈₄ cells transfected with siRNA directed against EGFR alongside mock-transfected cells. Mock-transfected cells responded similarly to previous experiments with untransfected cells, however, siRNA transfected cells failed to respond to EGF (Figure 4.4).

The Pan-SUMO antibody recognizes three human SUMO isoforms. To determine if the SUMO-1 isotype is involved in NKCC1 sumoylation, immunoprecipitations and Western blot analysis were repeated using a rabbit polyclonal antibody specific for SUMO-1. Western blot of SUMO-1 immunoprecipitates with anti-NKCC1 antibodies showed an increase in NKCC1 within 1 minute of EGF treatment (Figure 4.5 A). Likewise, western blot analysis of NKCC1 immunoprecipitates using the SUMO-1 antibody also showed an increase in SUMO-NKCC1 within 1 minute of treating T₈₄ cells with EGF (Figure 4.5 B), indicating that NKCC1 is likely modified by SUMO-1.

To determine if the EGFr mediated increase in SUMO-modified NKCC1 is a stimulus-specific response, T₈₄ cells were treated basolaterally for various times with the muscarinic agonist, carbachol. As discussed in detail earlier, stimulation of T₈₄ cells with carbachol transactivates EGFr through the release of endogenous TGF α . Interestingly, carbachol failed to induce the increase in SUMO-NKCC1 observed in experiments with EGF (Figure 4.6) suggesting that sumoylation of NKCC1 may be dependent on stimulus-specific activation of EGFr.

We proceeded to investigate ubiquitination of NKCC1, CFTR, Na⁺, K⁺ - ATPase, KCNN4, and CLCA2 in response to EGF or carbachol in T₈₄ cells. Cells were pretreated with the proteasome inhibitor, MG132, to prevent possible degradation, followed by EGF stimulation for 5 – 60 minutes. Cell lysates were immunoprecipitated using antibodies specific for each transporter, and ubiquitination of precipitated proteins was assessed by western blot. While no ubiquitination was observed with NKCC1, CFTR, KCNN4, or CLCA2 (data not shown), ubiquitination of Na⁺/K⁺ ATPase was seen as early as 5 minutes after stimulation with EGF (Figure 4.7). While EGF did not stimulate ubiquitination of NKCC1, carbachol had a dramatic

effect on NKCC1 ubiquitination (Figure 4.5). When considered along with what we have described regarding the regulation of NKCC1 internalization, this presented us with an interesting dichotomy: while carbachol, a cholinergic agonist that effects transactivation of EGFr stimulates ubiquitination and internalization of NKCC1, activation of EGFr through direct application of EGF stimulates sumoylation of NKCC1 and does not result in any internalization of NKCC1. It occurred to us that differential activation of EGFr might lead to divergent regulation of NKCC1 through opposing covalent modifications of the transporter. To better understand the relationship between ubiquitination and internalization, we proceeded to investigate the molecular mechanisms regulating ubiquitination of NKCC1.

We first sought to determine if ubiquitination of NKCC1 in response to cholinergic stimulation was dependent on transactivation of EGFr. Ubiquitination of NKCC1 was assessed in the presence or absence of the EGFr inhibitor, AG1478. Unlike the internalization of NKCC1, however, ubiquitination of NKCC1 appeared to occur independently of EGFr activation, as AG1478 had no effect on this response (Figure 4.9). This would suggest that either ubiquitination of NKCC1 is unrelated to internalization of the transporter, or that there are at least two distinct and convergent signaling pathways required for cholinergic-stimulated internalization of NKCC1, one dependent on EGFr activation, the other involving EGFr-independent ubiquitination of NKCC1. We hypothesized that the latter is true and that there are multiple, distinct signaling pathways elicited by cholinergic stimulation that are required for NKCC1 internalization. It would be quite a coincidence if cholinergic stimulation simultaneously induces NKCC1 internalization and modification by ubiquitin, a protein so closely associated with endosomal trafficking (96) and yet the two effects were unrelated.

To correlate NKCC1 internalization with ubiquitination, we attempted to inhibit ubiquitination using a newly described pharmacological inhibitor of ubiquitin E1 ligase, UBEI-41, or PYR-41 (104). While PYR-41 does indeed inhibit cholinergic-stimulated ubiquitination of NKCC1, at this time, studies examining the effect of PYR-41 on NKCC1 internalization and activity remain inconclusive. Internalization of NKCC1 using surface biotinylation, as described in Chapters Two and Three, was assessed in response to cholinergic stimulation in T₈₄ cells preincubated with PYR-41. PYR-41 did not appear to inhibit internalization of NKCC1 in response to cholinergic stimulation, rather, PYR-41 alone induced internalization of NKCC1. Similarly, in ⁸⁶Rb⁺ uptake assays used to assess NKCC1 activity in response to cholinergic stimulation, PYR-41 at times reversed the inhibitory effect carbachol had on forskolin-stimulated NKCC1 activity, however, at other times, PYR-41 alone inhibited forskolin-stimulated NKCC1 activity. Given the unexpected effect of PYR-41 alone inducing internalization of NKCC1 and inhibiting NKCC1 activity, we looked at ERK MAPK and EGFr phosphorylation in response to PYR-41. We examined the effect of a range of concentrations of PYR-41 from 5μM to 50μM on internalization of NKCC1 and ubiquitination of NKCC1 and found that all concentrations of PYR-41 that effectively inhibited ubiquitination (25μM to 50μM), also stimulated phosphorylation of ERK MAPK, phosphorylation of EGFr, and internalization of NKCC1. This may indicate that ubiquitination of NKCC1 is not required for internalization and that EGFr and ERK MAPK activation are sufficient. Alternatively, the higher concentrations of PYR-41 may have numerous off-target effects and may destabilize cytoskeletal elements and increase general membrane protein endocytotic processes.

Another approach to correlating ubiquitination of NKCC1 with its internalization involved taking a closer look at the effect of the proteasome inhibitor,

MG132. As described earlier, while NKCC1 was not degraded in response to cholinergic stimulation, MG132 inhibited internalization of NKCC1. We examined the effect of cholinergic stimulation on ubiquitination of NKCC1 in T₈₄ cells pretreated with MG132 and found that in addition to inhibiting internalization of NKCC1 as described in Chapter Three, MG132 also inhibits ubiquitination of the transporter (Figure 4.10). This suggests that internalization of NKCC1 may be associated with ubiquitination of the transporter. This also raises the prospect that perhaps the proteasome is not directly involved with internalization of NKCC1, rather, inhibiting proteasome activity may alter ubiquitination processes and indirectly inhibit internalization of NKCC1 through inhibiting ubiquitination of the transporter. There are reports that proteasome inhibitors including MG132 may inhibit ubiquitination processes in general, perhaps through a reduction in available free ubiquitin (105).

It is plausible that sumoylation, however transient, in response to direct stimulation with EGF may preclude subsequent ubiquitination and prevent internalization of NKCC1. Perhaps differential activation of EGFr in response to cholinergic stimulation fails to elicit or actively inhibits sumoylation mechanisms, thus allowing for ubiquitination of NKCC1. The effect of sumoylation on NKCC1 activity is a subject for further investigation, including any role it may play in altering ubiquitination of the transporter.

The contents of Chapter Four, in part or in full, are being prepared for submission for publication. (Chappell AE and Barrett KE. "Divergent regulation of NKCC1 through differential activation of EGFr: implications for intestinal ion transport" *In Preparation*. Alfred Chappell was the primary researcher and author for these chapters. Professor Kim Barrett supervised and directed the research that forms the basis for these chapters.

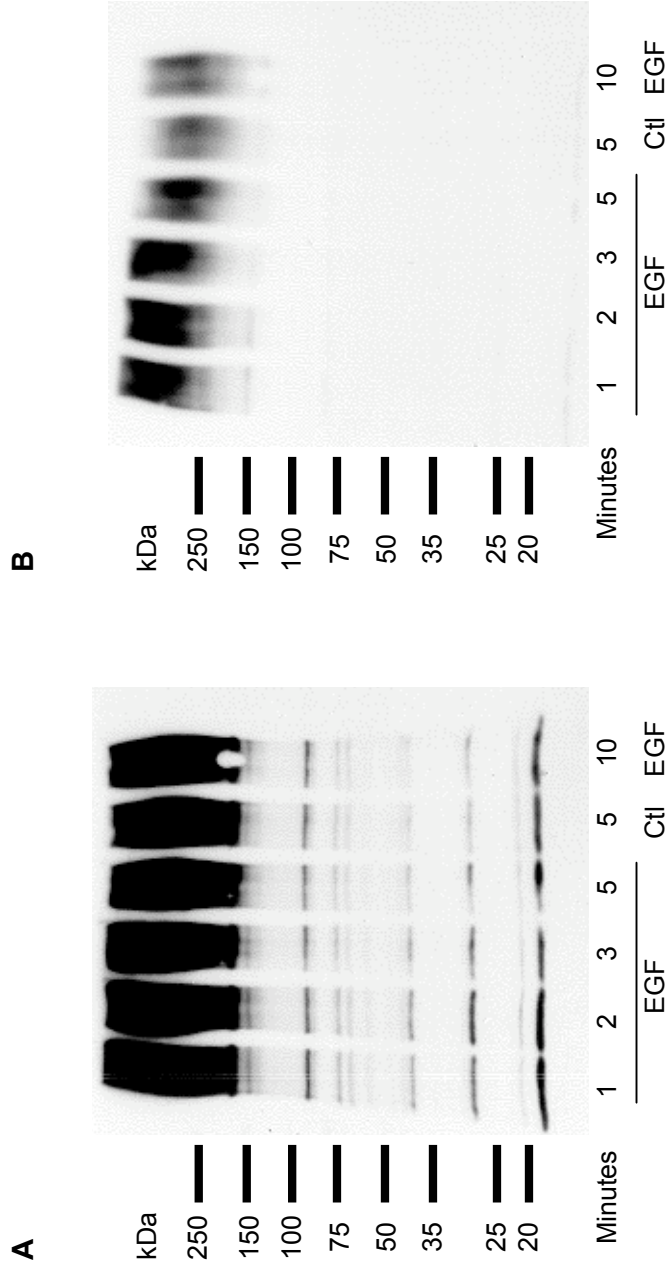

Figure 4.1 Stimulation of intestinal epithelial cells with EGF may induce sumoylation of some proteins. T₈₄ cells were treated with EGF (100ng/mL) for various times and cells lysates analyzed by Western blot using an anti-Pan-SUMO antibody. There is an increase in SUMO-modified proteins >150kD within 1 minute of treatment with EGF. A and B are the same blot with different exposure times to reveal different banding patterns.

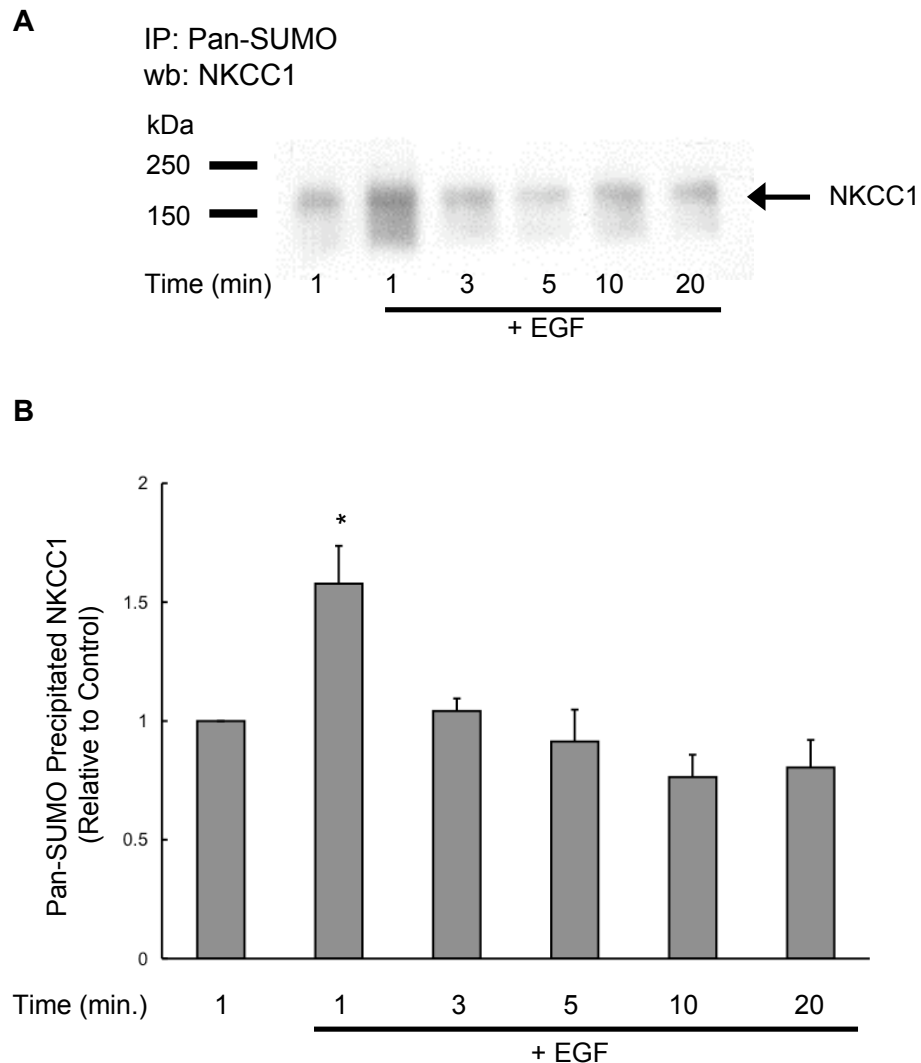

Figure 4.2 NKCC1 is rapidly and transiently sumoylated in response to EGF. T_{84} cells were treated basolaterally with 100ng/mL EGF for 1 to 20 minutes and cell lysates immunoprecipitated with a Pan-SUMO antibody. Pan-SUMO immunoprecipitates were western blotted for NKCC1. A 57% increase in coprecipitated NKCC1 was seen with 1 minute stimulation with EGF, however, by 3 minutes, the effect is no longer observed. A representative NKCC1 western blot of Pan-SUMO precipitates. B densitometric analysis of western blots (Means \pm SEM; statistical significance determined using ANOVA, with Tukey-Kramer Multiple Comparisons post-test: * $p < 0.05$ versus control, $n=4$).

IP: PanSUMO
wb: NKCC1

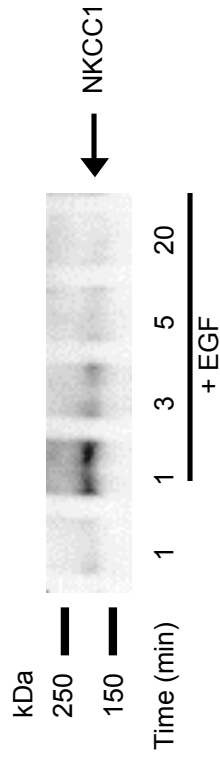

Figure 4.3 NKCC1 is covalently modified by SUMO. T₈₄ cells were treated with EGF (100ng/mL) for various times and cells were lysed under denaturing conditions (boiling 1% SDS). Lysates were immunoprecipitated using Pan-SUMO antibody and immunoprecipitates analyzed by western blot. An increase in Pan-SUMO- precipitated NKCC1 is seen in cells treated for 1 minute with EGF, indicating that there is an increase in covalent modification of NKCC1 with SUMO in response to EGF.

IP: PanSUMO
wb: NKCC1

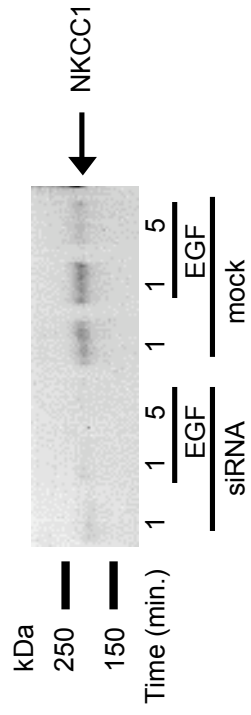

Figure 4.4 Knockdown of EGFR abolishes effect of EGF on sumoylation of NKCC1. T₈₄ cells were transfected with either an siRNA directed against EGFR, or a scramble control siRNA. Stimulation with EGF failed to induce sumoylation of NKCC1 in T₈₄ cells transfected with siEGFR, while control siRNA had no effect on this response to EGF.

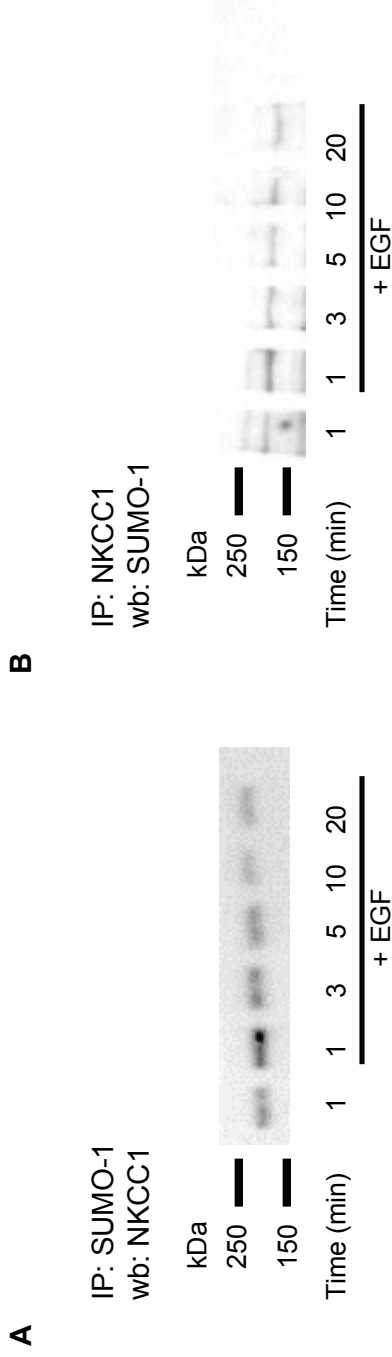

Figure 4.5 NKCC1 is modified by SUMO-1 isoform. T84 cells were treated for 1 - 20 minutes with 100ng/ mL EGF and cell lysates immunoprecipitated with either an antibody directed against SUMO-1 or NKCC1. A SUMO-1 immunoprecipitates were analyzed for NKCC1 by western blot and an increase in precipitated NKCC1 was found in cells treated with EGF for 1 minute. B NKCC1 immunoprecipitates were analyzed for SUMO-1 by western blot, and a similar increase in precipitated SUMO-1 was found in cells treated for 1 minute with EGF.

IP: PanSUMO
wb: NKCC1

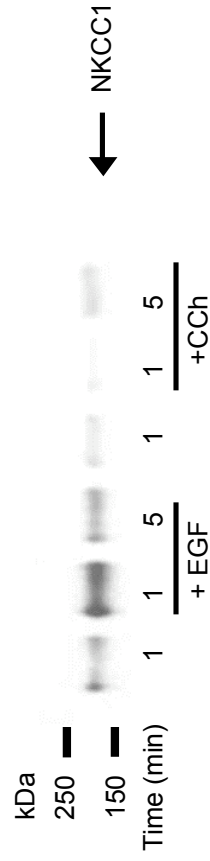

Figure 4.6 Cholinergic stimulation fails to induce sumoylation of NKCC1. T₈₄ cells were stimulated for 1 or 5 minutes with EGF or carbachol (CCh). Cell lysates were immunoprecipitated using a Pan-SUMO antibody and precipitates analyzed for NKCC1 by western blot. Consistent with previous experiments, 1 minute stimulation with EGF induced sumoylation of NKCC1, however, carbachol, failed to elicit such a response.



Figure 4.7 Na⁺/K⁺ ATPase is ubiquitinated in response to EGF stimulation. T₈₄ cells were stimulated with 100ng/ mL EGF for 5, 10, or 20 minutes. Cells were lysed and cell lysates immunoprecipitated with an antibody recognizing both mono- and poly- ubiquitinated substrates. Immunoprecipitates were analyzed for Na⁺, K⁺-ATPase α - subunit by western blot. An increase in Na⁺, K⁺-ATPase α - subunit was found in response to EGF at all time points.

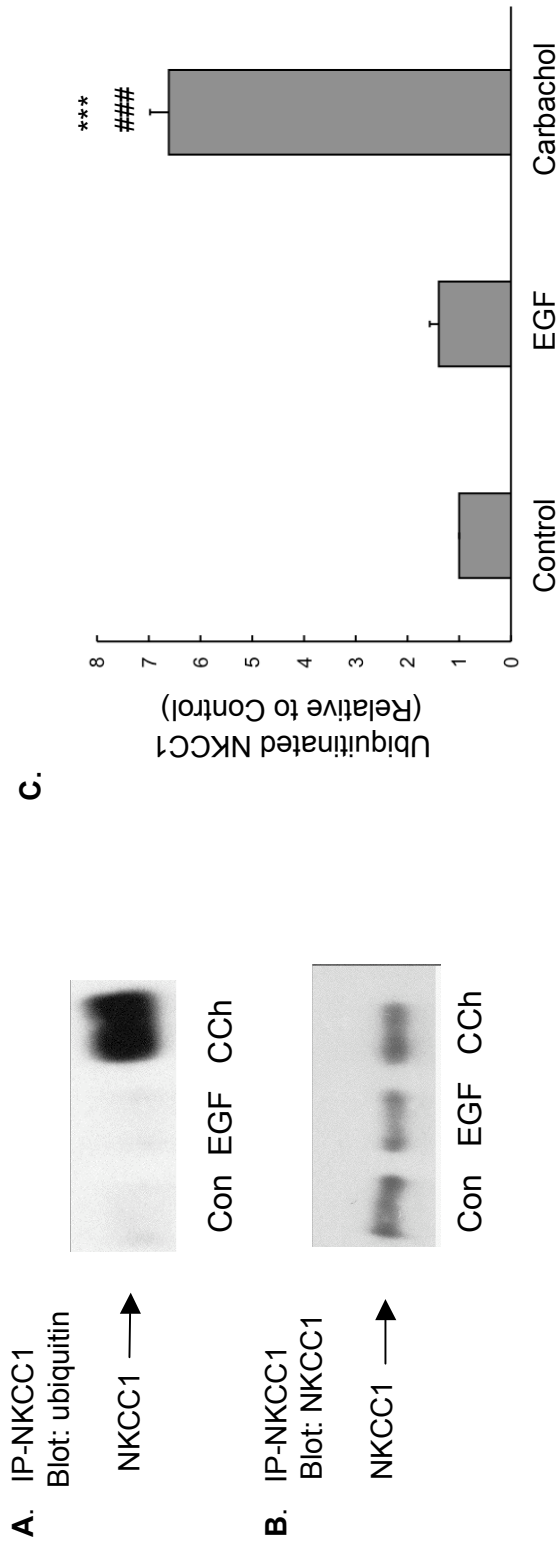

Figure 4.8 NKCC1 is ubiquitinated in response to carbachol, but not EGF. T_{84} cells were treated for 1 hour with carbachol or EGF and ubiquitination of NKCC1 assessed through NKCC1 immunoprecipitation followed by anti-ubiquitin western blot. *A*, representative western blots of immunoprecipitated NKCC1 showing ubiquitin-NKCC1 in response to EGF or carbachol. *B*, western blot in *A* was stripped and re-blotted for NKCC1 showing comparable levels of NKCC1 in each sample. *C*, densitometric analysis of ubiquitin-NKCC1 in response to carbachol expressed as corrected density (ub-NKCC1/ total NKCC1) (Means \pm SEM; statistical significance determined using ANOVA with Tukey-Kramer multiple comparisons post-test, *** $p < 0.001$ versus control and ### $p < 0.0001$ versus EGF).

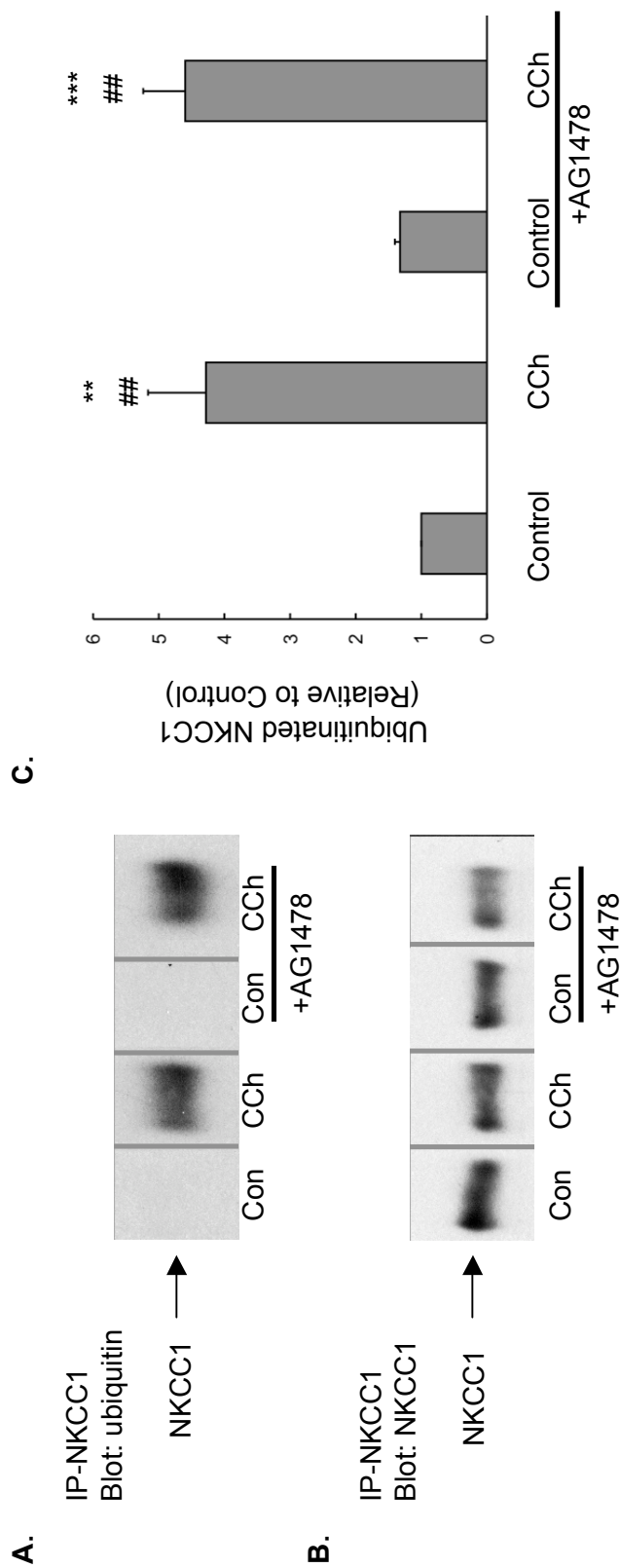

Figure 4.9 Cholinergic-stimulated ubiquitination of NKCC1 is independent of EGFr activation. T₈₄ cells were preincubated with AG1478 for 30 minutes before they were stimulated for 1 hour with 100 μ M carbachol. Ubiquitination of NKCC1 was assessed through NKCC1 immunoprecipitation followed by anti-ubiquitin western blot. A, representative western blots of immunoprecipitated NKCC1 showing ubiquitin-NKCC1. B, western blot in A was stripped and re-blotted for NKCC1 showing comparable levels of NKCC1 in each sample. C, densitometric analysis of ubiquitin-NKCC1 in response to carbachol in the presence or absence of AG1478 (Means \pm SEM; statistical significance determined using ANOVA with Tukey-Kramer multiple comparisons post-test, *** p<0.001, ** p<0.01 versus control and ## p<0.01 versus AG1478). The vertical lines in Panels A and B represent points where irrelevant bands were excised from the gel image. However, all bands shown are from the same gel image in each case.

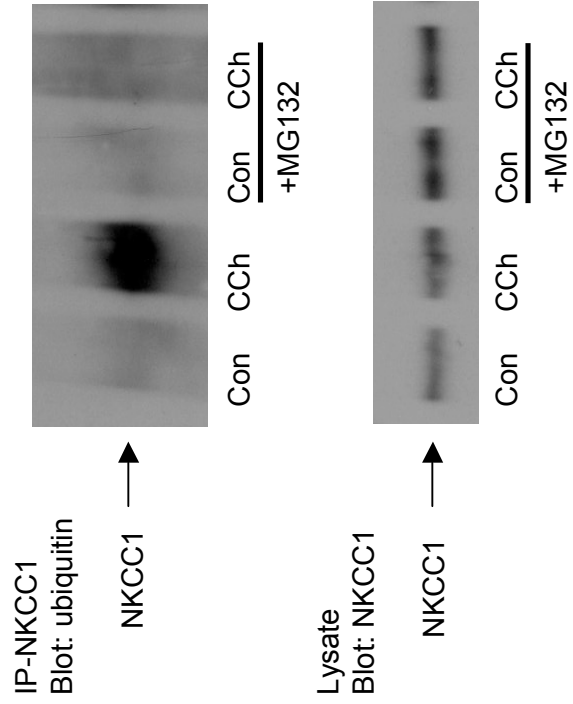

Figure 4.10 Cholinergic-stimulated ubiquitination of NKCC1 is inhibited by the proteasome inhibitor, MG132. T₈₄ cells were preincubated with 1 μM MG132 for 30 minutes before they were stimulated for 1 hour with carbachol. Ubiquitination of NKCC1 was assessed through NKCC1 immunoprecipitation followed by anti-ubiquitin western blot. A, representative western blots of immunoprecipitated NKCC1 showing ubiquitin-NKCC1. B, cell lysates from samples immunoprecipitated in A were western blotted for NKCC1 showing comparable levels of NKCC1 in each sample.

Chapter Five
Discussion

The overall goal of the work presented in this dissertation was to further characterize the role of divergent signaling through the EGF receptor in regulating chloride transport by identifying transporters that are differentially regulated by stimulus-specific activation of EGFr. To this end, we have determined that NKCC1 is differentially regulated in response to EGFr activation through direct stimulation with *bona fide* ligand versus transactivation in response to cholinergic stimulation. While cholinergic stimulation down-regulates NKCC1 activity through EGFr-dependent endocytosis of the transporter, activation of EGFr by direct application of EGF does not alter NKCC1 surface expression at the plasma membrane. Furthermore, endocytosis of NKCC1 involves modification of the transporter with ubiquitin, and while cholinergic stimulation results in ubiquitination of NKCC1, EGF instead elicits modification of NKCC1 by the closely related SUMO. Characterization of divergent signaling pathways engaged by differential activation of EGFr and the ultimate targets affected is important because EGFr plays a pivotal role in regulating the critical function of ion transport in the intestinal epithelium (1, 4, 18, 69, 71). The important nature of EGFr becomes even more apparent in light of the numerous examples by which the receptor is activated, not only by *bona fide* ligand, but also in response to seemingly disparate signaling initiated by GPCR agonists and other humoral and luminal stimuli (71, 74, 75, 78, 81, 83). Thus, EGFr is differentially activated in response to converging stimuli to effect divergent outcomes in net ion and water transport. Understanding the mechanisms of EGFr activation and the effects of differential activation of the receptor is important in addressing issues of infectious diarrhea, inflammatory bowel diseases, cystic fibrosis, constipation, as well as fully understanding the implications of targeting EGFr therapeutically in the treatment of cancers.

Proposed Model for Dynamic Regulation by EGFr

A relatively early point of divergent signaling from EGFr involves the determination as to whether receptor activation recruits MAPK signaling or PI3K signaling (70, 78, 82). Depending upon the nature of EGFr stimulation and the physiological setting in which the receptor is activated, EGFr activation may recruit MAPK signaling, PI3K signaling, or both with varying potency and the outcomes of EGFr activation may be determined by the relative balance of these downstream pathways (70).

We are proposing a model in which EGFr-dependent activation of MAPK signaling, as seen with transactivation of EGFr in response to cholinergic stimulation, induces internalization of NKCC1 in a process that also involves EGFr-independent ubiquitination of the transporter and thus, inhibits NKCC1 activity and chloride secretion (Figure 5.1 A). Alternatively, when EGFr activation results in predominant signaling through PI3K, as seen *in vitro* with stimulation by EGF, NKCC1 is maintained at the plasma membrane perhaps through SUMO modification that precludes subsequent ubiquitination of the transporter (Figure 5.1 B). Thus, EGFr stimulation may direct internalization of NKCC1 based upon whether the overall signaling milieu favors the MAPK or the PI3K pathway downstream from EGFr.

Such a model for divergent, counteracting signaling through EGFr has also been postulated to account for the discordant effects EGF stimulation has on sodium absorption by the epithelial sodium channel (ENaC) in healthy *versus* inflamed colonic tissues (69). Using *ex vivo* mouse models of colonic ion transport, McCole and colleagues demonstrated that as predicted by *in vitro* models, EGF stimulation of healthy colonic tissue inhibited both chloride secretion and sodium absorption (69). However, in dextran sulfate sodium (DSS) and multidrug resistance protein 1a

(*mdr1a* *-/-*) mouse models of inflammatory bowel disease, which already demonstrate impaired ion transport responses, stimulation with EGF actually increased sodium absorption by ENaC while having no effect on chloride secretion (69). It has been suggested that in healthy tissue, EGFr activation predominantly elicits ERK MAPK signaling while under conditions of inflammation, signaling *via* EGFr predominantly elicits PI3K signaling (69, 70). This shift in the principal signaling mediator recruited by EGFr can account for the differential effects of EGF stimulation on ENaC activity. Similar to the regulation we have described for NKCC1, wherein ERK activity leads to ubiquitin-associated internalization of NKCC1, ERK activity promotes ubiquitination and internalization of ENaC (106). Furthermore, PI3K signaling through PDK1 and SGK1, inhibits ubiquitination of ENaC resulting in maintenance of the transporter at the plasma membrane (106). Thus, it would appear that the ability for EGFr signaling to alternate between directing signaling through ERK and PI3K can account for the diverse and even opposing effects differential activation of EGFr has on ion transport. From EGFr-dependent inhibitory effects of IFN γ , growth hormone, and cholinergic stimulation, to EGFr-dependent prosecretory effects of PAR1 and PAR2, to the opposing effects *bona fide* ligand has in healthy versus inflamed tissue, the effects of EGFr activation may be determined by the relative extent to which ERK or PI3K is recruited by receptor activation (75, 76, 81, 85, 86). The experiments presented in this dissertation identify NKCC1 as a key site for divergent regulation of ion transport through EGFr and we hypothesize that NKCC1 may be down-regulated through internalization in response to a number of stimuli that act through directing EGFr signaling towards MAPK rather than PI3K. Conversely, conditions that direct EGFr signaling toward PI3K may serve to maintain NKCC1 at the plasma membrane. It will be interesting to examine how NKCC1 localization and activity are influenced in

response to transactivation of EGFr by other agents. While we have described EGFr- and MAPK-dependent internalization and inhibition of NKCC1 in response to GqPCR agonism, it would be interesting to see how, for instance, transactivation of EGFr through GsPCR agonism affects NKCC1. As discussed earlier, the full secretory effect of the GsPCR agonist, VIP requires EGFr transactivation and recruitment of PI3K signaling (74). Consistent with this, our hypothesis would predict a stabilization of NKCC1 at the plasma membrane in response to EGFr-initiated PI3K activity.

Clinical Implications

Fully understanding the complex regulation of epithelial ion transport is critical in the development of cystic fibrosis therapies. CF patients exhibit extremely impaired epithelial secretory function as the major cAMP-dependent chloride efflux conductor, CFTR, is dysfunctional (9). Of great interest, is the potential for treating CF through upregulating calcium-dependent secretory pathways in order to compensate for the lack of CFTR activity. As discussed in Chapter One, the promise of such a pathway is validated by the fact that CFTR (-/-) mice have increased expression of calcium-mediated secretion that compensates for the lack of CFTR, and these mice do not present with lung disease (42). Furthermore, a strain of CFTR (-/-) mice fails to exhibit any intestinal pathology as well (43). However promising, calcium-dependent secretory responses, including cholinergic-stimulated secretion, are characteristically transient due to concurrently or subsequently activated inhibitory mechanisms that serve to limit chloride secretion. Any CF therapy attempting to compensate for limited cAMP-dependent secretion by increasing calcium-dependent responses will have to address the transient nature of these responses. The identification of NKCC1 as a critical regulatory site in limiting cholinergic-stimulated,

calcium-dependent chloride secretion distinguishes this transporter as a potential therapeutic target for enhancing calcium-dependent chloride secretion. Pharmacological activators of calcium-dependent chloride secretion may be applied in combination with agents to direct EGFr signaling towards PI3K, rather than MAPK; inhibit EGFr; or inhibit ubiquitination and internalization of NKCC1 to prolong resulting chloride secretion. Work from Mark Williams' group demonstrated that simultaneous application of forskolin and carbachol results in rapid and sustained recycling of NKCC1 to the plasma membrane (26), suggesting that that cAMP-dependent agonist in conjunction with a calcium-dependent secretagogue could abrogate this limitation.

Our finding that cholinergic stimulation of chloride secretion is limited by EGFr-dependent internalization of NKCC1 may have clinical significance with regard to the use of EGFr inhibitors in the treatment of some cancers. An effective treatment of some cancers, the most common side effect of orally administered EGFr inhibitors is diarrhea (107, 108). We have demonstrated here that while NKCC1 is internalized in response to cholinergic stimulation, when EGFr is inhibited, NKCC1 remains at the plasma membrane. This may lead to prolonged chloride secretion in response to physiological cholinergic stimulation and thus result in diarrhea when inhibitors of EGFr are used therapeutically.

NKCC1 is widely distributed among many tissues and cell types beyond secretory epithelia and elucidating mechanisms by which NKCC1 is regulated is important for understanding, not only epithelial ion transport, but a variety of physiologically important processes. For one, NKCC1 may be involved in regulating cell growth and proliferation, a well-established function of EGFr. EGF has long been understood to promote cell growth and proliferation (68). Increased NKCC1 activity has also been implicated in promoting cell proliferation (109-111). Our model in

which EGFr-activation of PI3K leads to maintenance of NKCC1 at the plasma membrane may describe a system that not only enhances epithelial chloride secretion, but promotes cell proliferation, a function that could serve in epithelial repair in the setting of inflammation. Thus, better understanding the regulation of NKCC1 through EGFr is important for addressing cell growth and proliferation in inflammation, cancer, and development.

Future Direction

A number of studies should be pursued in order to further evaluate our hypothesis that it is the relative extent to which EGFr recruits MAPK or PI3K signaling pathways that determines the effect of EGFr activation on NKCC1 localization and activity. As discussed throughout this dissertation, EGFr is activated in response to a great variety of stimuli. We would like to determine how NKCC1 regulation is affected by different mechanisms of EGFr activation. GsPCR agonists, as mentioned earlier, stimulate chloride secretion through EGFr activation of PI3K; growth hormone inhibits chloride secretion through EGFr activation of MAPK pathways; does NKCC1 localization play a role in either of these responses? On the other hand, PAR1 and PAR2 agonists stimulate chloride secretion through EGFr-stimulated MAPK. What events under these conditions prevent MAPK-dependent internalization of NKCC1; does ubiquitination, or lack thereof, play a role?

Having demonstrated an effect of differential activation of EGFr on NKCC1 trafficking and activity in an *in vitro*, reductionist model of epithelial transport, studies in *ex vivo* and *in vivo* models should be examined to determine if this same effect is observed in more physiologically relevant conditions. This would not only be

important with regard to NKCC1, and its influence on chloride secretion, but ENaC and its role in sodium absorption.

Furthermore, identifying physiological conditions and stimuli that drive EGFr signaling toward predominantly MAPK signaling *versus* PI3K signaling is an important undertaking in order to understand and predict physiological responses. For instance, as alluded to earlier, preliminary studies from our group suggest that inflammatory cytokines direct EGF signaling through PI3K pathways while minimizing recruitment of MAPK pathways relative to signaling evoked in healthy epithelia. This switch in EGFr signaling may have critical implications in the treatment of inflammation in the clinic and may provide a basis for explaining how EGF inhibits water and electrolyte transport in healthy tissue, but enhances, even restores such transport in inflamed tissue already exhibiting impaired transport function. It will be important to elucidate the responses elicited by EGFr activation under settings of inflammation, as well as perhaps bacterial infections so as to better understand the role of the receptor in regulating ion transport under these pathophysiological conditions.

Conclusion

In conclusion, EGFr is a dynamic signaling nexus that is differentially activated in response to a variety of stimuli to evoke a number of disparate effects on vectorial ion and water transport in secretory and absorptive epithelia. We have identified NKCC1, a critical component of epithelial chloride secretion, as a site for differential regulation in response to stimulus-specific activation of EGFr. Cholinergic stimulation induces EGFr and MAPK-dependent internalization of NKCC1, an effect that is not observed when EGFr is activated by bona fide ligand. Furthermore, cholinergic-

stimulation results in EGFr-independent ubiquitination of NKCC1, an event that is very likely required for internalization of the transporter. Activation of EGFr by *bona fide* ligand stimulated transient modification of NKCC1 by the ubiquitin-like molecule, SUMO. We propose a model for EGFr-mediated regulation of NKCC1 by which recruitment of MAPK by EGFr allows for ubiquitin modification and induces internalization of NKCC1, while recruitment of PI3K by EGFr results in SUMO modification of NKCC1 that precludes ubiquitination of the transporter thus preventing internalization and maintaining NKCC1 activity at the plasma membrane. This mechanism of regulation of NKCC1 via EGFr may be relevant, not only to epithelial ion transport, but a number of physiological settings in which NKCC1 plays a vital role. Furthermore, this dichotomy of EGFr signaling dominated by ERK *versus* PI3K may be a critical aspect characterizing signaling through EGFr.

The contents of Chapter Five, in part or in full, are being prepared for submission for publication. (Chappell AE and Barrett KE. "Divergent regulation of NKCC1 through differential activation of EGFr: implications for intestinal ion transport" *In Preparation*. Alfred Chappell was the primary researcher and author for these chapters. Professor Kim Barrett supervised and directed the research that forms the basis for these chapters.

Figure 5.1 Divergent regulation of NKCC1 in response to differential activation of EGFr. Cholinergic stimulation of intestinal epithelium leads to transactivation of EGFr that recruits MAPK signaling pathways (green). EGFr-stimulated MAPK, in concert with additional signaling evoked by cholinergic stimulation, leads to ubiquitination and internalization of NKCC1. Alternatively, when EGFr is stimulated by direct application of bona fide ligand, PI3K signaling is recruited (orange), rather than MAPK; NKCC1 is sumoylated, and NKCC1 is maintained at the plasma membrane. Thus, EGFr stimulation may direct internalization of NKCC1 based upon whether the overall signaling milieu favors the MAPK or the PI3K pathway downstream from EGFr.

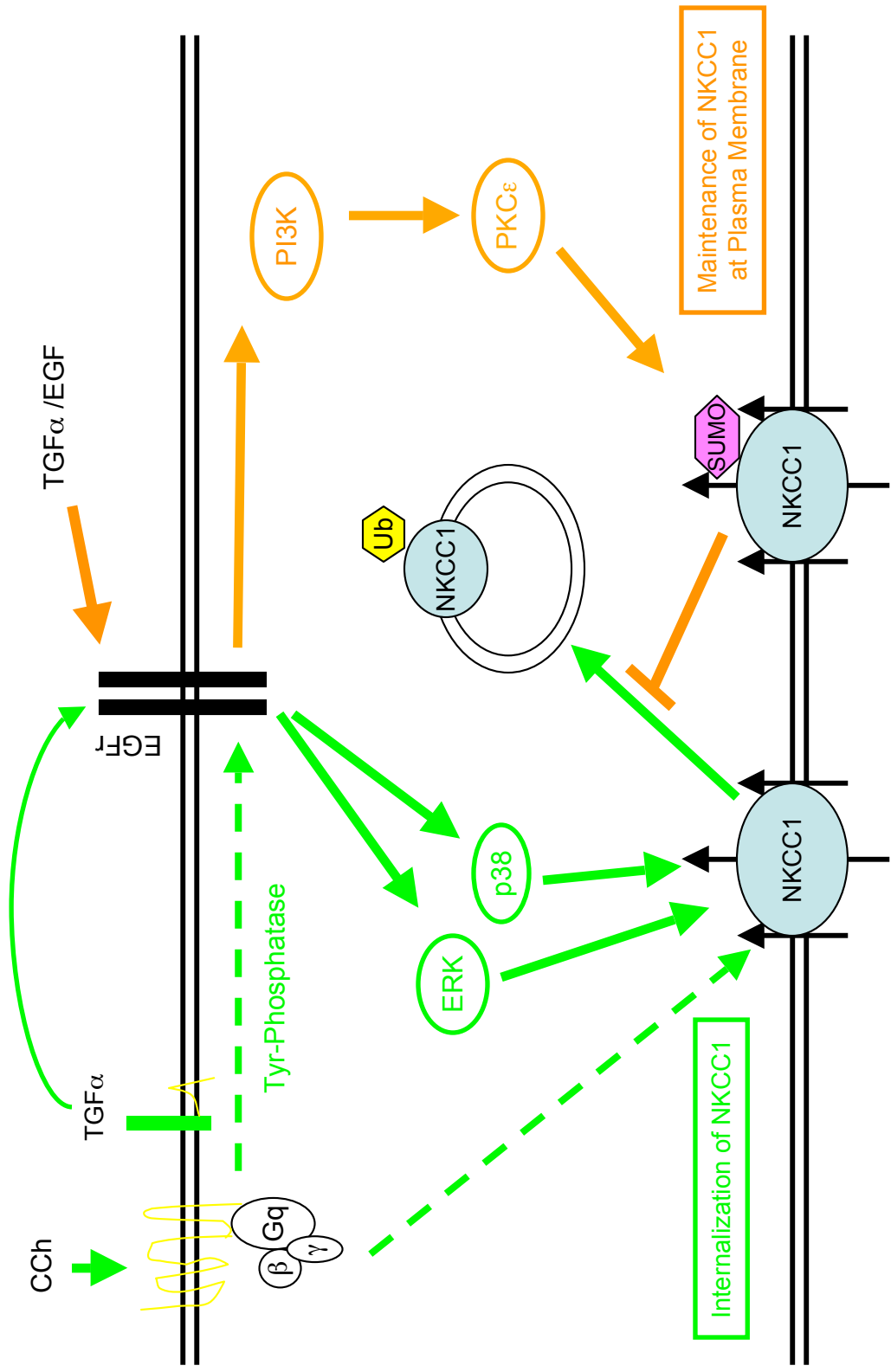

References

1. Barrett KE, Keely SJ. Integrative physiology and pathophysiology of intestinal electrolyte transport. In: Physiology of the Gastrointestinal Tract (Fourth Edition). Burlington: Academic Press; 2006. p. 1931-51.
2. Matsuzaki T, Tajika Y, Ablimit A, Aoki T, Hagiwara H, Takata K. Aquaporins in the digestive system. *Med Electron Microsc.* 2004 Jun;37(2):71-80.
3. Keely SJ, Barrett KE. Regulation of chloride secretion. novel pathways and messengers. *Ann N Y Acad Sci.* 2000;915:67-76.
4. Barrett KE, Keely SJ. Chloride secretion by the intestinal epithelium: Molecular basis and regulatory aspects. *Annu Rev Physiol.* 2000;62:535-72.
5. Haas M, Forbush B, 3rd. The Na-K-Cl cotransporter of secretory epithelia. *Annu Rev Physiol.* 2000;62:515-34.
6. Loewen ME, Forsyth GW. Structure and function of CLCA proteins. *Physiol Rev.* 2005 July 1;85(3):1061-92.
7. Eggermont J. Calcium-activated chloride channels: (un)known, (un)loved? *Proc Am Thorac Soc.* 2004 January 1;1(1):22-7.
8. Loewen ME, Bekar LK, Gabriel SE, Walz W, Forsyth GW. pCLCA1 becomes a cAMP-dependent chloride conductance mediator in caco-2 cells. *Biochem Biophys Res Commun.* 2002 Nov 8;298(4):531-6.
9. Greger R. Role of CFTR in the colon. *Annu Rev Physiol.* 2000 March 1;62(1):467-91.
10. Schroeder BC, Waldegger S, Fehr S, Bleich M, Warth R, Greger R, Jentsch TJ. A constitutively open potassium channel formed by KCNQ1 and KCNE3. *Nature.* 2000 Jan 13;403(6766):196-9.
11. Dharmasathaphorn K, Pandol SJ. Mechanism of chloride secretion induced by carbachol in a colonic epithelial cell line. *J Clin Invest.* 1986 Feb;77(2):348-54.
12. Vajanaphanich M, Schultz C, Tsien RY, Traynor-Kaplan AE, Pandol SJ, Barrett KE. Cross-talk between calcium and cAMP-dependent intracellular signaling pathways. implications for synergistic secretion in T84 colonic epithelial cells and rat pancreatic acinar cells. *J Clin Invest.* 1995 Jul;96(1):386-93.
13. Flores CA, Melvin JE, Figueroa CD, Sepulveda FV. Abolition of Ca²⁺-mediated intestinal anion secretion and increased stool dehydration in mice lacking the intermediate conductance Ca²⁺-dependent K⁺ channel Kcnn4. *J Physiol.* 2007 Sep 1;583(2):705-17.

14. Matos JE, Sausbier M, Beranek G, Sausbier U, Ruth P, Leipziger J. Role of cholinergic-activated KCa1.1 (BK), KCa3.1 (SK4) and KV7.1 (KCNQ1) channels in mouse colonic Cl⁻ secretion. *Acta Physiol (Oxf)*. 2007 Mar;189(3):251-8.
15. McEwan GT, Hirst BH, Simmons NL. Carbachol stimulates Cl⁻ secretion via activation of two distinct apical Cl⁻ pathways in cultured human T84 intestinal epithelial monolayers. *Biochim Biophys Acta*. 1994 Feb 17;1220(3):241-7.
16. Kidd JF, Thorn P. Intracellular Ca²⁺ and Cl⁻ channel activation in secretory cells. *Annu Rev Physiol*. 2000;62:493-513.
17. Barrett KE. Bowditch lecture. Integrated regulation of intestinal epithelial transport: Intercellular and intracellular pathways. *Am J Physiol Cell Physiol*. 1997 April 1;272(4):C1069-1076.
18. Kunzelmann K, Mall M. Electrolyte transport in the mammalian colon: Mechanisms and implications for disease. *Physiol Rev*. 2002 January 1;82(1):245-89.
19. Berger HA, Travis SM, Welsh MJ. Regulation of the cystic fibrosis transmembrane conductance regulator Cl⁻ channel by specific protein kinases and protein phosphatases. *J Biol Chem*. 1993 Jan 25;268(3):2037-47.
20. Gimenez I. Molecular mechanisms and regulation of furosemide-sensitive Na-K-Cl cotransporters. *Curr Opin Nephrol Hypertens*. 2006 Sep;15(5):517-23.
21. Pacheco-Alvarez D, Cristobal PS, Meade P, Moreno E, Vazquez N, Munoz E, Diaz A, Juarez ME, Gimenez I, Gamba G. The Na⁺:Cl⁻ cotransporter is activated and phosphorylated at the amino-terminal domain upon intracellular chloride depletion. *J Biol Chem*. 2006 Sep 29;281(39):28755-63.
22. Matthews JB. Molecular regulation of Na⁺-K⁺-2Cl⁻ cotransporter (NKCC1) and epithelial chloride secretion. *World J Surg*. 2002 Jul;26(7):826-30.
23. Kurihara K, Nakanishi N, Moore-Hoon ML, Turner RJ. Phosphorylation of the salivary Na⁺-K⁺-2Cl⁻ cotransporter. *Am J Physiol Cell Physiol*. 2002 Apr;282(4):C817-23.
24. D'Andrea L, Lytle C, Matthews JB, Hofman P, Forbush B, III, Madara JL. Na:K:2Cl cotransporter (NKCC) of intestinal epithelial cells. SURFACE EXPRESSION IN RESPONSE TO cAMP. *J Biol Chem*. 1996 November 15;271(46):28969-76.
25. Del Castillo IC, Fedor-Chaiken M, Song JC, Starlinger V, Yoo J, Matlin KS, Matthews JB. Dynamic regulation of Na⁺-K⁺-2Cl⁻ cotransporter surface expression by PKC- ϵ in Cl⁻-secretory epithelia. *Am J Physiol Cell Physiol*. 2005 Nov;289(5):C1332-42.
26. Reynolds A, Parris A, Evans LA, Lindqvist S, Sharp P, Lewis M, Tighe R, Williams MR. Dynamic and differential regulation of NKCC1 by calcium and cAMP in the native human colonic epithelium. *J Physiol*. 2007 July 15;582(2):507-24.

27. Matthews JB, Smith JA, Nguyen H. Modulation of intestinal chloride secretion at basolateral transport sites: Opposing effects of cyclic adenosine monophosphate and phorbol ester. *Surgery*. 1995 Aug;118(2):147,52; discussion 152-3.
28. Howard M, Jilling T, DuVall M, Frizzell RA. cAMP-regulated trafficking of epitope-tagged CFTR. *Kidney Int*. 1996 Jun;49(6):1642-8.
29. O'Mahony F, Toumi F, Mroz MS, Ferguson G, Keely SJ. Induction of Na⁺/K⁺/2Cl⁻ cotransporter expression mediates chronic potentiation of intestinal epithelial Cl⁻ secretion by EGF. *Am J Physiol , Cell Physiol*. 2008 June 1;294(6):C1362-1370.
30. Bertelsen LS, Eckmann L, Barrett KE. Prolonged interferon-gamma exposure decreases ion transport, NKCC1, and Na⁺-K⁺-ATPase expression in human intestinal xenografts in vivo. *Am J Physiol Gastrointest Liver Physiol*. 2004 Jan;286(1):G157-65.
31. Turnamian SG, Binder HJ. Regulation of active sodium and potassium transport in the distal colon of the rat. role of the aldosterone and glucocorticoid receptors. *J Clin Invest*. 1989 Dec;84(6):1924-9.
32. Cuppoletti J, Malinowska DH. Ion channels of the epithelia of the gastrointestinal tract. In: *Physiology of the Gastrointestinal Tract (Fourth Edition)*. Burlington: Academic Press; 2006. p. 1917-29.
33. Howard M, DuVall MD, Devor DC, Dong JY, Henze K, Frizzell RA. Epitope tagging permits cell surface detection of functional CFTR. *Am J Physiol*. 1995 Dec;269(6):C1565-76.
34. Takahashi A, Watkins SC, Howard M, Frizzell RA. CFTR-dependent membrane insertion is linked to stimulation of the CFTR chloride conductance. *Am J Physiol*. 1996 Dec;271(6):C1887-94.
35. Cunningham SA, Frizzell RA, Morris AP. Vesicular targeting and the control of ion secretion in epithelial cells: Implications for cystic fibrosis. *J Physiol*. 1995 Jan;482:27S-30S.
36. Greger R, Thiele II, Warth R, Bleich M. Does stimulation of NaCl secretion in *in vitro* perfused rectal gland tubules of squalus acanthias increase membrane capacitance? *Pflugers Arch*. 1998 Sep;436(4):538-44.
37. Ameen NA, Marino C, Salas PJ. cAMP-dependent exocytosis and vesicle traffic regulate CFTR and fluid transport in rat jejunum *in vivo*. *Am J Physiol Cell Physiol*. 2003 Feb;284(2):C429-38.
38. Guerra L, Fanelli T, Favia M, Riccardi SM, Busco G, Cardone RA, Carrabino S, Weinman EJ, Reshkin SJ, Conese M, Casavola V. Na⁺/H⁺ exchanger regulatory factor isoform 1 overexpression modulates cystic fibrosis transmembrane conductance regulator (CFTR) expression and activity in human airway 16HBE14o-cells and rescues ΔF508 CFTR functional expression in cystic fibrosis cells. *J Biol Chem*. 2005 Dec 9;280(49):40925-33.

39. Ma T, Thiagarajah JR, Yang H, Sonawane ND, Folli C, Galletta LJ, Verkman AS. Thiazolidinone CFTR inhibitor identified by high-throughput screening blocks cholera toxin-induced intestinal fluid secretion. *J Clin Invest*. 2002 Dec;110(11):1651-8.
40. Verkman AS, Lukacs GL, Galletta LJ. CFTR chloride channel drug discovery--inhibitors as antidiarrheals and activators for therapy of cystic fibrosis. *Curr Pharm Des*. 2006;12(18):2235-47.
41. Kent G, Iles R, Bear CE, Huan LJ, Griesenbach U, McKerlie C, Frndova H, Ackerly C, Gosselin D, Radzioch D, O'Brodovich H, Tsui LC, Buchwald M, Tanswell AK. Lung disease in mice with cystic fibrosis. *J Clin Invest*. 1997 Dec 15;100(12):3060-9.
42. Grubb BR, Boucher RC. Pathophysiology of gene-targeted mouse models for cystic fibrosis. *Physiol Rev*. 1999 Jan;79(1):S193-214.
43. Rozmahel R, Wilschanski M, Matin A, Plyte S, Oliver M, Auerbach W, Moore A, Forstner J, Durie P, Nadeau J, Bear C, Tsui LC. Modulation of disease severity in cystic fibrosis transmembrane conductance regulator deficient mice by a secondary genetic factor. *Nat Genet*. 1996 Mar;12(3):280-7.
44. Ball JM, Tian P, Zeng CQ-, Morris AP, Estes MK. Age-dependent diarrhea induced by a rotaviral nonstructural glycoprotein. *Science*. 1996 April 5;272(5258):101-4.
45. Morris AP, Scott JK, Ball JM, Zeng CQ-, O'Neal WK, Estes MK. NSP4 elicits age-dependent diarrhea and Ca^{2+} mediated I- influx into intestinal crypts of CF mice. *Am J Physiol Gastrointest Liver Physiol*. 1999 August 1;277(2):G431-444.
46. Agnel M, Vermaat T, Culouscou J. Identification of three novel members of the calcium-dependent chloride channel (CaCC) family predominantly expressed in the digestive tract and trachea. *FEBS Lett*. 1999 July 23;455(3):295-301.
47. Lipecka J, Bali M, Thomas A, Fanen P, Edelman A, Fritsch J. Distribution of ClC-2 chloride channel in rat and human epithelial tissues. *Am J Physiol Cell Physiol*. 2002 Apr;282(4):C805-16.
48. Cuppoletti J, Malinowska DH, Tewari KP, Li QJ, Sherry AM, Patchen ML, Ueno R. SPI-0211 activates T84 cell chloride transport and recombinant human ClC-2 chloride currents. *Am J Physiol Cell Physiol*. 2004 Nov;287(5):C1173-83.
49. Bali M, Lipecka J, Edelman A, Fritsch J. Regulation of ClC-2 chloride channels in T84 cells by TGF-alpha. *Am J Physiol Cell Physiol*. 2001 Jun;280(6):C1588-98.
50. MacDonald KD, McKenzie KR, Henderson MJ, Hawkins CE, Vij N, Zeitlin PL. Lubiprostone activates non-CFTR-dependent respiratory epithelial chloride secretion in cystic fibrosis mice. *Am J Physiol Lung Cell Mol Physiol*. 2008 Nov;295(5):L933-40.

51. Bijvelds MJ, Bot AG, Escher JC, de Jonge HR. Activation of intestinal Cl⁻ secretion by lubiprostone requires the cystic fibrosis transmembrane conductance regulator. *Gastroenterology*. 2009 May 16.
52. Flach CF, Lange S, Jennische E, Lonroth I. Cholera toxin induces expression of ion channels and carriers in rat small intestinal mucosa. *FEBS Lett*. 2004 Mar 12;561(1-3):122-6.
53. Jentsch TJ. Chloride and the endosomal-lysosomal pathway: Emerging roles of CLC chloride transporters. *J Physiol*. 2007 Feb 1;578(3):633-40.
54. Jentsch TJ. CLC chloride channels and transporters: From genes to protein structure, pathology and physiology. *Crit Rev Biochem Mol Biol*. 2008 Jan-Feb;43(1):3-36.
55. Warth R, Hamm K, Bleich M, Kunzelmann K, von Hahn T, Schreiber R, Ullrich E, Mengel M, Trautmann N, Kindle P, Schwab A, Greger R. Molecular and functional characterization of the small Ca²⁺-regulated K⁺ channel (rSK4) of colonic crypts. *Pflugers Arch*. 1999 Sep;438(4):437-44.
56. Liao T, Wang L, Halm ST, Lu L, Fyffe RE, Halm DR. K⁺ channel KVLQT1 located in the basolateral membrane of distal colonic epithelium is not essential for activating cl⁻ secretion. *Am J Physiol Cell Physiol*. 2005 Sep;289(3):C564-75.
57. Devor DC, Frizzell RA. Modulation of K⁺ channels by arachidonic acid in T84 cells. II. activation of a Ca²⁺-independent K⁺ channel. *Am J Physiol*. 1998 Jan;274(1):C149-60.
58. Barrett KE, Bigby TD. Involvement of arachidonic acid in the chloride secretory response of intestinal epithelial cells. *Am J Physiol*. 1993 Feb;264(2):C446-52.
59. Lytle C. Activation of the avian erythrocyte Na-K-Cl cotransport protein by cell shrinkage, cAMP, fluoride, and calyculin-A involves phosphorylation at common sites. *J Biol Chem*. 1997 Jun 13;272(24):15069-77.
60. Liedtke CM, Wang X, Smallwood ND. Role for protein phosphatase 2A in the regulation of calu-3 epithelial Na⁺-K⁺-2Cl⁻, type 1 co-transport function. *J Biol Chem*. 2005 Jul 8;280(27):25491-8.
61. Darman RB, Flemmer A, Forbush B. Modulation of ion transport by direct targeting of protein phosphatase type 1 to the Na-K-Cl cotransporter. *J Biol Chem*. 2001 Sep 14;276(37):34359-62.
62. Delpire E, Gagnon KB. SPAK and OSR1, key kinases involved in the regulation of chloride transport. *Acta Physiol (Oxf)*. 2006 May-Jun;187(1-2):103-13.
63. Gagnon KBE, England R, Delpire E. Characterization of SPAK and OSR1, regulatory kinases of the Na-K-2Cl cotransporter. *Mol Cell Biol*. 2006 January 15;26(2):689-98.

64. Matthews JB, Smith JA, Tally KJ, Awtrey CS, Nguyen H, Rich J, et al. Na-K-2Cl cotransport in intestinal epithelial cells: influence of chloride efflux and F-actin on regulation of cotransporter activity and bumetanide binding. *J Biol Chem*. 1994 Jun 3;269(22):15703-9.
65. Matthews JB, Tally KJ, Smith JA. Activation of intestinal Na-K-2Cl cotransport by 5'-AMP requires F-actin remodeling. *Am J Surg*. 1995 Jan;169(1):50,5; discussion 55-6.
66. Matthews JB, Smith JA, Hrnjez BJ. Effects of F-actin stabilization or disassembly on epithelial Cl⁻ secretion and Na-K-2Cl cotransport. *Am J Physiol*. 1997 Jan; 272(1): C254-62.
67. Uribe JM, Barrett KE. Nonmitogenic actions of growth factors: An integrated view of their role in intestinal physiology and pathophysiology. *Gastroenterology*. 1997 Jan; 112(1):255-68.
68. Sibilio M, Kroismayr R, Lichtenberger BM, Natarajan A, Hecking M, Holcman M. The epidermal growth factor receptor: From development to tumorigenesis. *Differentiation*. 2007 Nov;75(9):770-87.
69. McCole DF, Rogler G, Varki N, Barrett KE. Epidermal growth factor partially restores colonic ion transport responses in mouse models of chronic colitis. *Gastroenterology*. 2005 Aug;129(2):591-608.
70. McCole DF, Barrett KE. Decoding epithelial signals: Critical role for the epidermal growth factor receptor in controlling intestinal transport function. *Acta Physiol (Oxf)*. 2009 Jan;195(1):149-59.
71. Uribe JM, Gelbmann CM, Traynor-Kaplan AE, Barrett KE. Epidermal growth factor inhibits Ca²⁺-dependent Cl⁻ transport in T84 human colonic epithelial cells. *Am J Physiol*. 1996 Sep;271(3 Pt 1):C914-22.
72. McCole DF, Truong A, Bunz M, Barrett KE. Consequences of direct versus indirect activation of epidermal growth factor receptor in intestinal epithelial cells are dictated by protein-tyrosine phosphatase 1B. *J Biol Chem*. 2007 May 4;282(18):13303-15.
73. McCole DF, Keely SJ, Coffey RJ, Barrett KE. Transactivation of the epidermal growth factor receptor in colonic epithelial cells by carbachol requires extracellular release of transforming growth factor-alpha. *J Biol Chem*. 2002 Nov 8;277(45):42603-12.
74. Bertelsen LS, Barrett KE, Keely SJ. Gs protein-coupled receptor agonists induce transactivation of the epidermal growth factor receptor in T84 cells: Implications for epithelial secretory responses. *J Biol Chem*. 2004 Feb 20;279(8):6271-9.
75. Chow JY, Carlstrom K, Barrett KE. Growth hormone reduces chloride secretion in human colonic epithelial cells via EGF receptor and extracellular regulated kinase. *Gastroenterology*. 2003 Oct;125(4):1114-24.

76. Keely SJ, Uribe JM, Barrett KE. Carbachol stimulates transactivation of epidermal growth factor receptor and mitogen-activated protein kinase in T84 cells. IMPLICATIONS FOR CARBACHOL-STIMULATED CHLORIDE SECRETION. *J Biol Chem.* 1998 October 16;273(42):27111-7.
77. Barrett KE, Smitham J, Traynor-Kaplan A, Uribe JM. Inhibition of Ca^{2+} -dependent Cl^- secretion in T84 cells: Membrane target(s) of inhibition is agonist specific. *Am J Physiol.* 1998 Apr;274(4):C958-65.
78. Keely SJ, Barrett KE. ErbB2 and ErbB3 receptors mediate inhibition of calcium-dependent chloride secretion in colonic epithelial cells. *J Biol Chem.* 1999 Nov 19;274(47):33449-54.
79. Chow JY, Barrett KE. Role of protein phosphatase 2A in calcium-dependent chloride secretion by human colonic epithelial cells. *Am J Physiol Cell Physiol.* 2007 Jan;292(1):C452-9.
80. Chow JY, Uribe JM, Barrett KE. A role for protein kinase C epsilon in the inhibitory effect of epidermal growth factor on calcium-stimulated chloride secretion in human colonic epithelial cells. *J Biol Chem.* 2000 Jul 14;275(28):21169-76.
81. Uribe JM, McCole DF, Barrett KE. Interferon-gamma activates EGF receptor and increases TGF- α in T84 cells: Implications for chloride secretion. *Am J Physiol Gastrointest Liver Physiol.* 2002 Oct;283(4):G923-31.
82. Keely SJ, Calandrella SO, Barrett KE. Carbachol-stimulated transactivation of epidermal growth factor receptor and mitogen-activated protein kinase in T₈₄ cells is mediated by intracellular Ca^{2+} , PYK-2, and p60^{src}. *J Biol Chem.* 2000 Apr 28; 275(17): 12619-25.
83. Daub H, Weiss FU, Wallasch C, Ullrich A. Role of transactivation of the EGF receptor in signalling by G-protein-coupled receptors. *Nature.* 1996 Feb 8; 379(6565): 557-60.
84. Keely SJ, Barrett KE. p38 mitogen-activated protein kinase inhibits calcium-dependent chloride secretion in T84 colonic epithelial cells. *Am J Physiol Cell Physiol.* 2003 Feb;284(2):C339-48.
85. Buresi MC, Buret AG, Hollenberg MD, MacNaughton WK. Activation of proteinase-activated receptor 1 stimulates epithelial chloride secretion through a unique MAP kinase- and cyclo-oxygenase-dependent pathway. *FASEB J.* 2002 Oct;16(12):1515-25.
86. van der Merwe JQ, Hollenberg MD, MacNaughton WK. EGF receptor transactivation and MAP kinase mediate proteinase-activated receptor-2-induced chloride secretion in intestinal epithelial cells. *Am J Physiol Gastrointest Liver Physiol.* 2008 Feb;294(2):G441-51.

87. Dharmsathaphorn K, McRoberts JA, Mandel KG, Tisdale LD, Masui H. A human colonic tumor cell line that maintains vectorial electrolyte transport. *Am J Physiol.* 1984 Feb;246(2):G204-8.
88. Barrett KE. Positive and negative regulation of chloride secretion in T84 cells. *Am J Physiol Cell Physiol.* 1993 October 1;265(4):C859-868.
89. Leithe E, Rivedal E. Epidermal growth factor regulates ubiquitination, internalization and proteasome-dependent degradation of connexin43. *J Cell Sci.* 2004 Mar 1;117(7):1211-20.
90. Venglarik CJ, Bridges RJ, Frizzell RA. A simple assay for agonist-regulated Cl and K conductances in salt-secreting epithelial cells. *Am J Physiol.* 1990 Aug;259(2):C358-64.
91. Matthews JB, Smith JA, Nguyen H. Modulation of intestinal chloride secretion at basolateral transport sites: Opposing effects of cyclic adenosine monophosphate and phorbol ester. *Surgery.* 1995 Aug;118(2):147,52; discussion 152-3.
92. Lerdrup M, Hommelgaard AM, Grandal M, van Deurs B. Geldanamycin stimulates internalization of ErbB2 in a proteasome-dependent way. *J Cell Sci.* 2006 Jan 1; 119(1): 85-95.
93. van Kerkhof P, Govers R, Alves dos Santos CM, Strous GJ. Endocytosis and degradation of the growth hormone receptor are proteasome-dependent. *J Biol Chem.* 2000 Jan 21;275(3):1575-80.
94. Strous GJ, Govers R. The ubiquitin-proteasome system and endocytosis. *J Cell Sci.* 1999 May;112 (Pt 10)(Pt 10):1417-23.
95. Ulrich HD. The SUMO system: An overview. *Methods Mol Biol.* 2009;497:3-16.
96. Hicke L, Dunn R. Regulation of membrane protein transport by ubiquitin and ubiquitin-binding proteins. *Annu Rev Cell Dev Biol.* 2003;19:141-72.
97. Kerscher O, Felberbaum R, Hochstrasser M. Modification of proteins by ubiquitin and ubiquitin-like proteins. *Annu Rev Cell Dev Biol.* 2006;22:159-80.
98. Johnson ES. Protein modification by SUMO. *Annu Rev Biochem.* 2004;73:355-82.
99. Hunter T, Sun H. Crosstalk between the SUMO and ubiquitin pathways. *Ernst Schering Found Symp Proc.* 2008;1(1):1-16.
100. Rajan S, Plant LD, Rabin ML, Butler MH, Goldstein SA. Sumoylation silences the plasma membrane leak K⁺ channel K2P1. *Cell.* 2005 Apr 8;121(1):37-47.
101. Abriel H, Staub O. Ubiquitylation of ion channels. *Physiology (Bethesda).* 2005 Dec;20:398-407.

102. Malbert-Colas L, Nicolas G, Galand C, Lecomte MC, Dhermy D. Identification of new partners of the epithelial sodium channel alpha subunit. *C R Biol.* 2003 Jul;326(7):615-24.
103. Giorgino F, de Robertis O, Laviola L, Montrone C, Perrini S, McCowen KC, et al. The sentrin-conjugating enzyme mUbc9 interacts with GLUT4 and GLUT1 glucose transporters and regulates transporter levels in skeletal muscle cells. *Proc Natl Acad Sci U S A.* 2000 Feb 1;97(3):1125-30.
104. Yang Y, Kitagaki J, Dai RM, Tsai YC, Lorick KL, Ludwig RL, et al. Inhibitors of ubiquitin-activating enzyme (E1), a new class of potential cancer therapeutics. *Cancer Res.* 2007 Oct 1;67(19):9472-81.
105. Xu Q, Farah M, Webster JM, Wojcikiewicz RJ. Bortezomib rapidly suppresses ubiquitin thiolesterification to ubiquitin-conjugating enzymes and inhibits ubiquitination of histones and type I inositol 1,4,5-trisphosphate receptor. *Mol Cancer Ther.* 2004 Oct;3(10):1263-9.
106. Soundararajan R, Melters D, Shih IC, Wang J, Pearce D. Epithelial sodium channel regulated by differential composition of a signaling complex. *Proc Natl Acad Sci U S A.* 2009 May 12;106(19):7804-9.
107. Mendelsohn J. EGF receptors as a target for cancer therapy. *Trans Am Clin Climatol Assoc.* 2004;115:249,53; discussion 253-4.
108. Sridhar SS, Seymour L, Shepherd FA. Inhibitors of epidermal-growth-factor receptors: A review of clinical research with a focus on non-small-cell lung cancer. *Lancet Oncol.* 2003 Jul;4(7):397-406.
109. Shiozaki A, Miyazaki H, Niisato N, Nakahari T, Iwasaki Y, Itoi H, et al. Furosemide, a blocker of Na⁺/K⁺/2Cl⁻ cotransporter, diminishes proliferation of poorly differentiated human gastric cancer cells by affecting G0/G1 state. *J Physiol Sci.* 2006 Dec;56(6):401-6.
110. Lee HA, Jeong H, Kim EY, Nam MY, Yoo YJ, Seo JT, et al. Bumetanide, the specific inhibitor of Na⁺-K⁺-2Cl⁻ cotransport, inhibits 1alpha,25-dihydroxyvitamin D3-induced osteoclastogenesis in a mouse co-culture system. *Exp Physiol.* 2003 Sep;88(5):569-74.
111. Panet R, Marcus M, Atlan H. Overexpression of the Na⁺/K⁺/Cl⁻ cotransporter gene induces cell proliferation and phenotypic transformation in mouse fibroblasts. *J Cell Physiol.* 2000 Jan;182(1):109-18.